



esac

BepiColombo SGS

Mercury Planetary Orbiter (MPO)

European Space Astronomy Centre
P . O . B o x 7 8
28691 Villanueva de la Cañada
M a d r i d
S p a i n
T e l . (3 4) 9 1 8 1 3 1 1 0 0
w w w . e s a . i n t

MIXS Experiment to Archive Interface Control Document (MIXS EAICD)

BC-MIX-IF-006 MIXS EAICD.docx

Prepared by MIXS Team
Reference BC-MIX-IF-006
Issue 1
Revision 0
Date of Issue 14/05/2026
Status Issued
Document Type ICD

ESA UNCLASSIFIED – For Internal Use



APPROVAL

Title MIXS Experiment to Archive Interface Control Document (MIXS EAICD)	
Issue 1	Revision 0
Date 14/05/2026	
Custodian	Signature
Simon Lindsay (MIXS Operations Scientist)	
Prepared by	Signature
Simon Lindsay (MIXS Operations Scientist)	
Daniela Coia (BepiColombo SGS Archive Scientist)	
Approved by	Signature
Geraint Jones (BepiColombo MPO Project Scientist)	
Mark Bentley (Planetary Science Archive Coordinator)	
Authorised by	Signature
Emma Bunce (MIXS Principal Investigator)	



CHANGE LOG

Reason for change	Issue	Revision	Date
First draft	D	0	09/12/2016
Updated with feedback from SGS	D	1	22/06/2017
Updated with information from BC-MIX-SP-009 to allow it to be obsolete	D	2	
Added information on calibration products	D	3	07/08/2019
Updated with feedback from SGS	D	4	07/10/2019
Large update with new CAL definitions and first draft DER products added	D	5	08/02/2022
Update with feedback from SGS and information about ground calibration data and geometry products	D	6	22/07/2022
Minor updates from MIXS Archive Review	D	7	11/03/2024
Second round of Archive Review updates	D	8	29/08/2024
Update with details of pipeline v1.0 products and public issue of cruise data	1	0	14/05/2026

CHANGE RECORD

Issue 1	Revision 0		
Reason for change	Date	Pages	Paragraph(s)
First draft	09/12/2016	All	All
Updated with feedback from SGS	22/06/2017	All	All
Added information on calibration products	07/08/2019	16-17 57-58	2.4 5.5.1.2
Updated with feedback from SGS	07/10/2019	All	All
Update with DER information	08/02/2022	All	All
Update with feedback from SGS and ground calibration and geometry info	22/07/2022	All	All
Updates from MIXS Archive Review	11/03/2024	All	All
More Archive Review updates	29/08/2024	36-41	4.5.1.1-4.5.1.8
Public issue of cruise data	14/05/2026	All	All



DISTRIBUTION LIST

Recipient	Organisation	Recipient	Organisation
E. Bunce	University of Leicester	G. Jones	ESA (SRE-SM)
A. Martindale	University of Leicester	S. Besse	ESA (SRE-SM)
S. Lindsay	University of Leicester	S. Martinez	ESA (SRE-OD)
O. Blake	University of Leicester		
T. Tikkanen	University of Leicester	M. Bentley	ESA (SRE-OS)
G. Hall	University of Leicester	D. Coia	ESA
		BepiColombo SGS	ESA (SRE-OD)
		BepiColombo SAT	ESA (SRE-OE)



Table of contents:

1 Introduction9

1.1 Purpose and Scope9

1.2 Applicable Documents9

1.3 Reference Documents9

1.4 Abbreviations and Acronyms10

2 MIXS Instrument Description.....12

2.1 Science Objectives12

2.2 Instrument telemetry sensors15

2.2.1 Temperature monitoring15

2.3 Operational Modes15

2.3.1 Permitted mode transitions16

2.4 Calibration17

2.4.1 On-ground Calibration17

2.4.2 In-flight Calibration19

2.4.3 Science data calibration21

3 Data Generation and Analysis Process23

3.1 Scientific Measurements23

3.1.1 Energy resolution and binning23

3.1.2 MIXS-T scientific measurements24

3.1.3 MIXS-C scientific measurements24

3.2 Data Flow Overview25

3.3 Data Generation26

3.3.1 Raw Data Generation26

3.3.2 Calibrated Data Generation27

3.3.3 Derived Data Generation28

3.3.4 Miscellaneous Data Generation29

3.4 Validation30

3.4.1 Instrument Team Validation30

3.4.2 Peer Review30

3.5 Data Delivery Schedule30

4 Data Organisation and Contents31

4.1 Format and Conventions31

4.2 Bundle Content and Structure31

4.3 Logical Identifier Formation31

4.3.1 Bundle LID formation31

4.3.2 Collection LID formation31

4.3.3 Product LID formation32

4.4 Data Directory Naming Convention32

4.5 MIXS Science Data Organisation35

4.5.1 MIXS bundle35

5 Data product formats.....43

5.1 Raw Data Products43

5.1.1 Raw Science Data Products43

5.1.2 Raw Calibration Data Products48

5.1.3 Raw Housekeeping Data Products48



5.2 Calibrated Data Products 52

5.2.1 Calibrated Science Data Products..... 53

5.2.2 Calibrated Housekeeping Products 57

5.3 Derived Data Products 63

5.3.1 Derived Surface Composition Branch Products..... 63

5.3.2 Derived Hermean Environment Branch Products 67

5.4 Supplementary Products Formats 69

5.4.1 Browse Products 69

5.4.2 MIXS calibration products 70

5.4.3 MIXS geometry products..... 72

Annex 1: Telemetered temperatures and voltages 77

Annex 2: Citing MIXS data 79

List of Figures:

Figure 1 Schematic and photograph of MIXS 13

Figure 2 MIXS detector pixel coordinate system; the instrument (MIXS-C or MIXS-T as appropriate) reference frame is shown in red, although note that the origin of these frames is not at the centre of the detector as shown here. Detector boresight is at the vertex shared by pixels [31,31], [31,32], [32,31] and [32,32] 13

Figure 3 Permitted DPU mode transitions 16

Figure 4 Permitted MIXS mode transitions 17

Figure 5 Angular positions for MIXS-T calibration scans in azimuth (ψ) and elevation (ϕ) of the target relative to the instrument boresight direction. Red cells represent required scans. All angles are in arcminutes. 20

Figure 6 Angular positions for MIXS-C calibration scans in azimuth (ψ) and elevation (ϕ) of the target relative to the instrument boresight direction. Red cells represent required scans. All angles are in degrees. 20

Figure 7 Block diagram of the MIXS data processing pipeline 25

Figure 9 Hierarchical diagram of MIXS bundle subdirectory structure 35

Figure 10 Schematic of MIXS with locations of thermistors providing telemetry 78



List of Tables:

Table 1 MIXS scientific requirements 12

Table 2 MIXS-T parameters of interest 14

Table 3 MIXS-C parameters of interest 14

Table 4 Summary of DPU modes and allowed MIXS modes for each 15

Table 5 MIXS calibration inputs used in pipeline calibration activities; inputs listed in **bold** are MIXS telemetry products available in MIXS data collections (see Section 4.5.1) 22

Table 6 Approximate effects of MIXS amplitude downsampling settings 24

Table 7: List of deliverables with corresponding delivery schedule (to SGS) 30

Table 8: Collections within the MIXS bundle 36

Table 9 Data products within the **data_raw** collection 37

Table 10 Data products within the **data_calibrated** collection 38

Table 11 Table_Character rows within MIXS-T RAW pixel list containing pixel list header data *The time offset is negative with respect to TIME_UTC and is included to allow the calculation of the original packet time (TIME_UTC – TIME_OFFSET) 44

Table 12 Columns in Table_Character object within MIXS-T raw pixel list containing event locations and amplitudes 44

Table 13 Columns in MIXS-T RAW detector image metadata 45

Table 14 Detector image extension in MIXS-T RAW detector image 45

Table 15 Columns in MIXS-C RAW pixel list header file. *The time offset is negative with respect to TIME_UTC and is included to allow the calculation of the original packet time (TIME_UTC – TIME_OFFSET) 46

Table 16 Columns in MIXS-C RAW pixel list events file 46

Table 17 Columns in MIXS-C RAW detector image metadata 46

Table 18 Detector image extension in MIXS-C RAW detector image 47

Table 19 Columns in MIXS-C RAW histogram products 47

Table 20 Summary of available RAW level calibration data products. Products marked with * are produced by MIXS-C only; others are produced by both MIXS-T and MIXS-C 48

Table 21 Columns in MIXS-T/C RAW housekeeping report products; field marked with * is not included in the MIXS-T report 51

Table 22 Columns in MIXS/SIXS DPU RAW housekeeping report products 52

Table 23 Columns in Table_Character objects within MIXS-T CAL pixel list containing pixel list header data
53

Table 24 Columns in Table_Character objects within MIXS-T CAL pixel list containing event locations and energies 55

Table 25 Values of the QUALITY_FLAG field in MIXS CAL pixel lists 55

Table 25 Columns in MIXS-C CAL pixel list header file 56

Table 26 Columns in MIXS-C CAL pixel list events file 57

Table 27 Columns in MIXS-C CAL histogram products 57

Table 28 Columns in MIXS-T/C CAL housekeeping report products; field marked with * is not included in the MIXS-T report 61

Table 29 Columns in MIXS/SIXS DPU CAL housekeeping report products 62

Table 30 MIXS DER elemental abundance map products 64

Table 31 Additional MIXS DER elemental abundance maps (existence TBC) 64

Table 32 Structure of (top) MIXS abundance maps and (bottom) abundance error maps 65

Table 33 MIXS DER absolute elemental abundance maps (existence TBC). *Carbon absolute abundance map only possible if C is resolved (see above) 66

Table 34 Structure of (top) MIXS absolute abundance maps and (bottom) MIXS absolute abundance error maps 66

Table 36 MIXS-[T/C] gain map image extension within the MIXS-[T/C] calibration gain map product 70



Table 37 MIXS-[T/C] temperature coefficient map image extension within the MIXS-[T/C] calibration gain map product 70

Table 38 MIXS 10-bit energy redistribution function array object..... 71

Table 39 MIXS 9-bit energy redistribution function array object..... 71

Table 40 MIXS 8-bit energy redistribution function array object 71

Table 41 MIXS optic response function array object..... 72

Table 42 Columns in MIXS-T pixel list geometry product..... 74

Table 43 Columns in MIXS-C pixel list geometry product..... 76

Table 44 MIXS temperature sensors in housekeeping reports (sensors marked * can also be telemetered in some science products) 77

Table 45 MIXS telemetered voltages 79



1 INTRODUCTION

1.1 Purpose and Scope

This Experiment-to-Archive Interface Control Document (EAICD) describes the format and content of the Mercury Imaging X-ray Spectrometer (MIXS) archived data. It includes descriptions of the data products and associated metadata, including the data format, content, and generation pipeline.

The specifications described in this EAICD apply to all MIXS products submitted for archive to ESA's planetary science archive (PSA), maintained by the BepiColombo Science Ground Segment (SGS), for all phases of the BepiColombo mission.

This document includes descriptions of archive products that are produced by both the MIXS team and by the SGS. However, it is intended as the definitive document to aid users of the MIXS archives and this distinction should be invisible to the user.

1.2 Applicable Documents

The following documents, of the issue given hereunder, are pertinent to the extent specified herein and impose requirements to the SGS or the SGS schedule. They are referenced in the form [AD XX]:

- [AD.01] [PDS4 Standards Reference](#) (SR)
- [AD.02] [PDS4 Data Dictionary](#) (DDDB)
- [AD.03] [PDS4 Information Model Specification](#) (IM)

1.3 Reference Documents

The following documents, of the issue given hereunder, although not part of this document, amplify or clarify its contents. If no issue given, the most recent issue should be used. They are referenced in the form [RD.XX]:

- [RD.01] BC-SGS-PL-014, BepiColombo Science Data Generation, Validation and Archiving Plan
- [RD.02] BC-SGS-TN-026, BepiColombo Archiving Guide
- [RD.03] BC-SGS-TN-042, BepiColombo Data Handling and Archiving Concept
- [RD.04] BC-SGS-ICD-010, MIXS Data Processing Agreement
- [RD.05] [PDS4 Data Providers Handbook](#) (DPH)
- [RD.06] [PDS4 Concepts](#)
- [RD.07] BC-MIX-PL-013 MIXS ground calibration plan
- [RD.08] BC-MIX-PL-014 MIXS in orbit calibration plan
- [RD.09] BC-SGS-TN-054 MPO Pointing Plan
- [RD.10] BC-MIX-UM-001, MIXS Instrument User Manual
- [RD.11] BC-MIX-SP-009, MIXS Science Pipeline Specification
- [RD.12] BC-SGS-SP-017, MIXS Pipeline Description Document
- [RD.13] BC-MIX-LI-132, MIXS DHA product templates
- [RD.14] BC-SIX-IC-00002, SIXS Experiment to Archive Interface Control Document
- [RD.15] BC-EST-RS-02517, MIXS Experiment Interface Document, Part B



- [RD.16] BC-SGS-PL-014, Science Data Generation Validation and Archiving Plan
- [RD.17] B.A. Archinal et. al., 2009. Report of the IAU Working Group on Cartographic Coordinates and Rotational Elements: 2009. *Celest. Mech. Dyn. Astr.* 109:101-135
- [RD.18] Bunce, E.J., Martindale, A., Lindsay, S.T., et.al. The BepiColombo Mercury Imaging X-ray Spectrometer: science goals, instrument performance and operations. *Space Science Reviews* **216**, 126 (2020).
- [RD.19] Toor, A. and Seward, F.D. The Crab Nebula as a calibration source for X-ray astronomy. *The Astronomical Journal* **79** (10) 995-999 (1974).

1.4 Abbreviations and Acronyms

AD: Applicable Document
ADC: Analogue to Digital Converter
ADU: Analogue to Digital Unit
ASIC: Application Specific Integrated Circuit
BOL: Beginning Of Life
CAL: Calibrated (data processing level)
DEPFET: Depleted P-channel Field Effect Transistor
DER: Derived (data processing level)
DN: Digital Number
DPU: Data Processing Unit
EDDS: EGOS (ESA Ground Operations System) Data Dissemination System
ENG: Enhanced RAW/Engineering (data processing level)
EOL: End Of Life
FOV: Field Of View
FPA: Focal Plane Assembly
FWHM: Full Width at Half Maximum
FWZM: Full Width at Zero Maximum
HK: Housekeeping
ICP: Interplanetary Cruise Phase
IT: Instrument Team
LID: Logical Identifier
LIDVID: Versioned Logical Identifier
NECP: Near Earth Commissioning Phase
NMCP: Near Mercury Commissioning Phase
MCP: Microchannel Plate
MIB: Mission Information Base
MIXS: Mercury Imaging X-ray Spectrometer
MIXS-C: MIXS Collimator
MIXS-T: MIXS Telescope
MOI: Mercury Orbital Insertion
MOM: MIXS Optics Module
MPO: Mercury Planetary Orbiter
MSP: Mercury Science Phase
MTA: Mercury True Anomaly



PAR: Partially calibrated (data processing level)
PDS: Planetary Data System
PI: Principal Investigator
PRT: Platinum Resistance Thermometer
PSA: Planetary Science Archive
QLA: Quick Look Analysis
RD: Reference Document
SGS: Science Ground Segment
SIXS: Solar Intensity X-ray and particle Spectrometer
SPICE: Spacecraft, Planet, Instrument, C-matrix and Events (navigation toolkit)
TBC: To Be Confirmed
TBD: To Be Determined
TBI: To Be Inserted
TC: Telecommand
TM: Telemetry
UTC: Coordinated Universal Time
VID: Version Identifier



2 MIXS INSTRUMENT DESCRIPTION

2.1 Science Objectives

The primary objectives of the Mercury Imaging X-ray Spectrometer (MIXS) per [RD.18] are:

- produce global elemental abundance maps and determine key elements to an accuracy of 5-50% depending on concentration and the element under examination,
- perform spatially resolved measurements of these elemental abundances, achieving high spatial resolution mapping where solar conditions permit,
- Investigate particle-induced X-ray fluorescence associated with energetic particles interacting with the surface

These objectives lead to a set of science requirements, again per [RD.18].

Science Requirement	Requirement
Cover the energy range of the key elemental lines (Na, Mg, Al, Si, P, S, Cl, K, Ca, Ti, Cr, Mn, Fe, Ni)	Detector must be efficient at EOL in the energy range $0.5 \text{ keV} < E < 7.5 \text{ keV}$
Resolve the fluorescence lines of the key elements	EOL energy resolution must be $< 200 \text{ eV}$ at 1 keV
Allow resolution of low-energy fluorescence lines	Detect fluorescence at the Fe-L line (705 eV) and below. Ideally, detect lines down to C-K (277 eV) to test the theory that graphite is present in low-reflectance material (LRM) and the oxidation state of metallic species.
Achieve near-global coverage of the surface (i.e. overlapping swaths at all latitudes)	Field of view $> 1^\circ$
Measure X-ray events with sufficient time resolution to allow measurements at a spatial resolution of 1 km when solar state allows, and to resolve magnetospheric events	Time resolution $< 1 \text{ s}$ (MIXS-T) and $< 10 \text{ s}$ (MIXS-C)
Achieve comparable spatial resolution to imaging instruments on the mission, when solar state allows	Angular resolution $< 9 \text{ arcmin}$ (MIXS-T)
Monitor solar flux in order to calculate absolute elemental abundances	Monitor solar activity using SIXS-X [RD.14]
Separate the contributions from different X-ray producing mechanisms	Monitor particle flux with SIXS-P and other particle instruments where possible

Table 1 MIXS scientific requirements

MIXS is an X-ray fluorescence spectrometer composed of two sub-instruments, the MIXS Telescope (MIXS-T; the larger, circular cross-section component seen in Figure 1) and MIXS Collimator (MIXS-C; the smaller, square cross-section component). Each sub-instrument uses a microchannel plate (MCP) to focus X-rays on identical 64×64 pixel, $19.2 \times 19.2 \text{ mm}$ DEPFET detectors. Pixel coordinates within these detectors are used frequently in science products and follow the convention summarised in Figure 2.

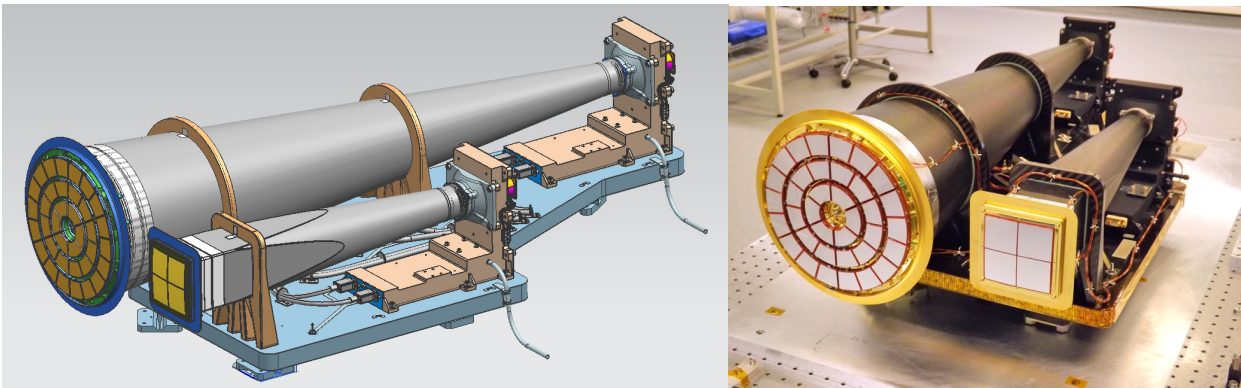

Figure 1 Schematic and photograph of MIXS

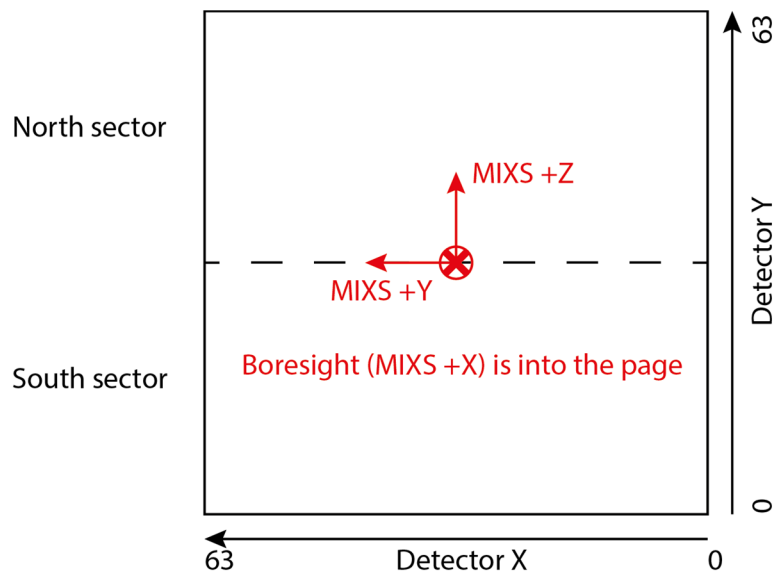

Figure 2 MIXS detector pixel coordinate system; the instrument (MIXS-C or MIXS-T as appropriate) reference frame is shown in red, although note that the origin of these frames is not at the centre of the detector as shown here. Detector boresight is at the vertex shared by pixels [31,31], [31,32], [32,31] and [32,32]

With MIXS-T, the MCP array is slumped to approximate a Wolter Type I (paraboloid-hyperboloid) geometry, with two layers of 36 MCPs, slumped to spheres of 4000 mm and 1333 mm respectively. The resultant optic has a focal length of 1 m and allows imaging to a resolution dependent on the strength of the surface X-ray signal and the geometry of the observation (i.e. altitude).

With MIXS-C, a single layer of 4 MCPs is slumped to a sphere of radius 550 mm. MIXS-C is a non-imaging collimator with a larger grasp than MIXS-T, allowing better spectral statistics at lower levels of surface X-ray flux.



MIXS is operated in tandem with the Solar Intensity X-ray and particle Spectrometer (SIXS), which provides the necessary knowledge of the input (solar) X-ray spectrum required to perform X-ray fluorescence spectroscopy. For more details, see the SIXS equivalent of this document [RD.14].

MIXS-T and MIXS-C share a data processing unit (DPU) with SIXS. The DPU handles and transmits instrument telemetry and data to the spacecraft.

Important instrument parameters are summarised in Table 2 and Table 3.

Parameter	Value
Field of view	1.1° square
Spectral resolution	139/200 eV FWHM at BOL/EOL
Aperture	210 mm diameter circle
Focal length	1000 mm
Detector pixels	64×64
Scale per pixel	1.0 arcmin
Pixel pitch	300 µm
Exposure time	100 ms
Angular resolution ¹	~9 arcmin
Spatial resolution at periapsis ¹	1000 m/pixel
Time resolution	3 s

Table 2 MIXS-T parameters of interest

Parameter	Value
Field of view	10° square
Spectral resolution	139/200 eV FWHM at BOL/EOL
Aperture	80×80 mm square
Focal length	550 mm
Detector pixels	1×1 ²
Pixel pitch	19.2 mm ³
Exposure time	4 s
Angular resolution	10° (i.e. FOV)
Spatial resolution at periapsis	42 km
Time resolution	3 s

Table 3 MIXS-C parameters of interest

¹ Optimal resolution is dependent upon high solar X-ray flux

² The MIXS-C detector is identical to that of MIXS-T and comprises 64×64 pixels, but MIXS-C histogram is binned across all pixels, and for most purposes the detector is considered as if it comprised a single large pixel. Pixel addresses are available in certain data products where the differences in gain and offset per pixel is relevant.

³ This figure refers to the MIXS-C detector as one pixel



2.2 Instrument telemetry sensors

2.2.1 Temperature monitoring

The temperature of the MIXS detectors is often important from a science user perspective as it can directly affect instrument noise and thus calibration. For this reason selected temperature telemetry is contained within some MIXS science products.

Instrument thermal monitoring is, in general, provided by platinum resistance thermometers (PRTs) mounted on the optical modules and focal plane assemblies of both detectors. However, temperature diodes are also present in the detector chip. Temperatures from all sensors are reported in telemetry, while science data contain one temperature value, selected by telecommand from the three temperature diodes located within the detector.

A complete list of all PRTs is supplied in Annex 1.

The detector is separated into north (N) and south (S) sectors. Each sector consists of half the detector; the N sector in the +Z direction from the midpoint, and the S sector in the –Z direction. One of the temperature sensors reported in science telemetry is located in the N sector, one in the S sector, and one mounted on the hybrid (detector electronics) which monitors the temperature of the readout ASICs. In normal circumstances the telemetered temperature will be one of the detector temperatures (i.e. N or S).

2.3 Operational Modes

The MIXS DPU, MIXS-T and MIXS-C all have separate, although in some cases dependent, operational modes defined. DPU modes are OFF, STANDBY, OPERATIONAL and SAFE. For all DPU modes except OPERATIONAL, MIXS-T and MIXS-C modes must be OFF. For DPU OPERATIONAL, MIXS-T and MIXS-C may be in any mode. MIXS modes are OFF, SAFE, STANDBY, SCIENCE and ANNEALING. MIXS-T and MIXS-C modes are independent. All modes have a single-digit numerical value in TM, shown in Table 4.

DPU mode		MIXS-T mode		MIXS-C mode	
0	Off	1	Off	1	Off
1	Standby	1	Off	1	Off
2	Operational	1	Off	1	Off
		2	Safe	2	Safe
		3	Standby	3	Standby
		4	Science	4	Science
		5	Annealing	5	Annealing
3	Safe	1	Off	1	Off

Table 4 Summary of DPU modes and allowed MIXS modes for each

MIXS science products can only be produced in SCIENCE mode, in which mode both MIXS-T and MIXS-C will be placed during nominal operations. This is the only mode that allows for production



of pixel lists, detector images and MIXS-C histograms. ANNEALING and STANDBY modes are used for instrument annealing and other maintenance activities, and housekeeping and diagnostic products only are produced. SAFE is a contingency mode in which no housekeeping and diagnostic products are produced, and can only be transitioned to OFF mode. No products are generated when the instruments are in OFF mode.

2.3.1 Permitted mode transitions

Figures 3 and 4 show permitted mode transitions for the DPU and MIXS. All permitted transitions can be commanded by TC, and some may be enforced by FDIR action.

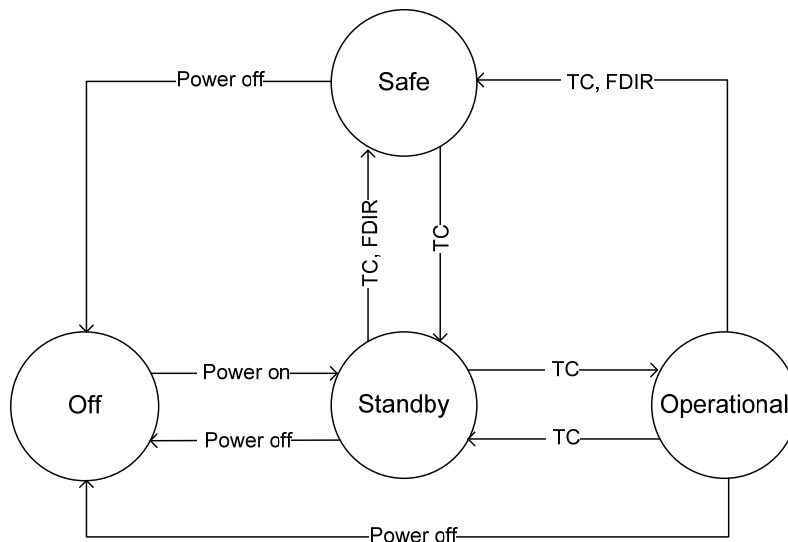
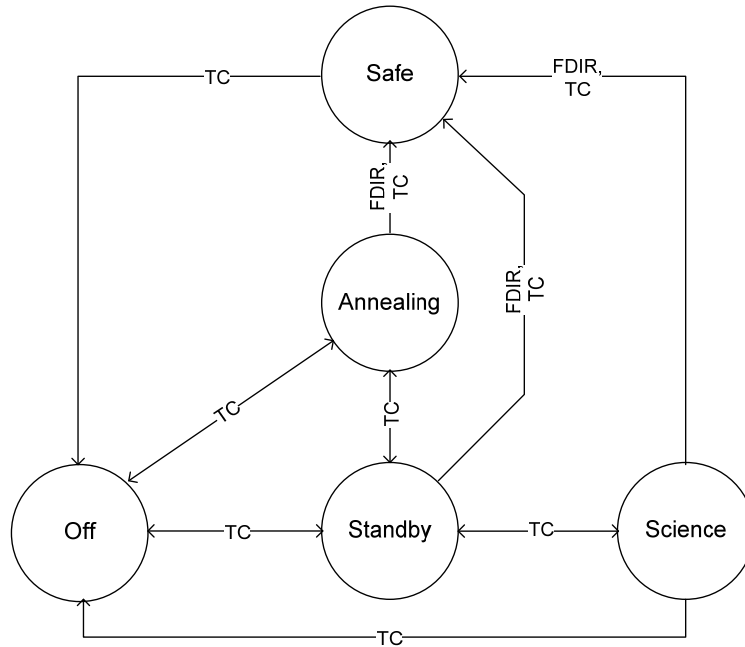

Figure 3 Permitted DPU mode transitions



Notes:
 1. Mode is always OFF when DPU is not in Operational mode.
Figure 4 Permitted MIXS mode transitions

2.4 Calibration

2.4.1 On-ground Calibration

On-ground calibration is described fully in [RD.07] and summarised below.

The summary description of the calibration is in progress and will be updated in a later version of this document.

2.4.1.1 Thermistor calibration

PRTs as used by MIXS (see Section 2.2) are self-calibrating to the accuracy required. The associated ADC levels are provided by the DPU manufacturer and standard PRT calibrations from resistance to temperature are used. No further measurements were required.

The temperature diodes in the detectors (see Section 2.2) were calibrated against the PRTs. This is calculated from the gain calibration described below in section 2.4.1.2. A one-dimensional thermal model showed that the detector was a fixed 10°C warmer than the PRT location, this scaling was used in the diode calibration. The absolute temperature calibration is likely to be accurate on the order of ±2K, with relative calibration much



better than this. Thus, ΔT will be known to much higher accuracy than absolute temperature. There is no temperature dependence in the detector which is a strong function of absolute temperature on the order of $\pm 2K$ [RD.07].

2.4.1.2 Energy calibration

The overall gain of the system (detector \rightarrow asteroid (read-out ASIC) \rightarrow buffer amplifier \rightarrow ADC) and its temperature coefficient are required to allow calibration of ADC to energy. This ensures that MIXS-C histogrammed data are corrected for temperature variation over the observation.

In general when analysing spectral data of this type, it is necessary to correct for the gain and the offset of the analogue to digital converter in order to correct the measured values (in digital numbers) into calibrated values in physical units. In the case of MIXS, the correction for the ADC offset is done onboard, meaning the number telemetered is already corrected such that 0 in digital numbers represents 0keV and only the gain needs to be corrected for on ground.

2.4.1.2.1 Gain

Gain in $eV.ADU^{-1}$ is calculated individually per pixel along with the temperature coefficient of the total gain of the amplifier chain. The full field is illuminated by an ^{55}Fe calibration source and measurements taken at varying detector and hybrid temperatures. Three calibration lines are measured – Mn-K α (5.9keV), Mn-K β (6.5keV) and the Mn-K α escape peak (4.16keV) and the resulting spectrum analysed to calculate the gain of the electronics to determine the size of each ADC channel in energy units (keV).

As the gain of the detector is temperature dependent, this experiment was performed at multiple temperatures and the results analysed to determine both the gain and its (linear) variation with temperature. The resulting gain map is produced at a reference temperature, along with a separate temperature coefficient map containing the gradients of the temperature variation (the gain of each pixel is linearly dependent on temperature). Thus the individual temperature-corrected gain $G(x,y)$ of each pixel is given by:

$$G(x,y) = G_{map}(x,y) - (T_{ref} - T)g(x,y)$$

where $G_{map}(x,y)$ is the gain for pixel (x,y) in the gain map, T_{ref} is the reference temperature, T is the measured temperature from either HK or from the packet header, and $g(x,y)$ is the temperature correction coefficient for pixel (x,y) . This temperature coefficient is also referred to as “gain gradient” in some documents.

There are two different values of T_{ref} , for the North and South sectors (see Figure 2) of the detector respectively. The appropriate reference temperature should be used based on the location of the pixel being calibrated. The values in $g(x,y)$ are calculated on the basis of uncalibrated values of both T_{ref} and T , so **raw values only** for both of these parameters should be used in the gain calibration process.

$G_{map}(x,y)$, $g(x,y)$ and both values of T_{ref} are all provided in the calibration gain maps product, named MIXS-[T/C]_GAIN_MAP, MIXS-[T/C]_TEMPERATURE_COEFFICIENT_MAP and MIXS-[T/C]_REFERENCE_TEMPERATURES respectively. This product is generated on ground and described in detail in Section 5.4.2.1. The measured temperature T is telemetered in the relevant science products – see Sections 5.1.1 and 5.2.1.



2.4.1.2.2 Linearity

This will be included in a later version of this document

2.4.1.2.3 Converting MIXS-C histogram bins to energies

This will be included in a later version of this document

2.4.2 In-flight Calibration

In-flight optic calibration of MIXS will take place before the primary science mission, after separation of the Mercury Transfer Module (MTM). A second optic calibration may be conducted after the nominal one-year mission has been completed, although only if there is a perceived need at the time. Further re-calibration is not intended, but ad hoc requests for off-pointings towards the Crab nebula (or a secondary target) may be made if needed as a result of anomalies. It is considered that more than one of these requests is very unlikely.

No routine dedicated measurement campaigns for calibration only are foreseen outside the start of the primary and extended missions.

2.4.2.1 Crab nebula

The primary target for on-orbit optic calibration of MIXS is the Crab nebula, a strong astronomical X-ray source with a well-known spectrum [RD.19]. The Crab is located at 5h 34 31.94s RA and +22° 00' 52.2" DEC.

The Crab X-ray spectrum is modelled by

$$\frac{dN}{dE} = 10E^{-2.05} e^{-\sigma n_H} \text{ photons.cm}^{-2}\text{s}^{-1}\text{keV}^{-1}$$

[RD.08], where $n_H = 3 \times 10^{21} \text{ cm}^{-2}$, σ is the absorption and scattering cross section, and E is energy in keV.

After separation of the MTM, both MIXS-T and MIXS-C will perform a series of 30 minute scans at different angular offsets, summarised in Figure 5 and Figure 6. Using the spectral form described above and the MIXS-T effective area curve lead to an estimated event rate of $\sim 0.1 \text{ s}^{-1}\text{bin}^{-1}$ during each scan. The total number of scans is 21 for MIXS-T and 23 for MIXS-C.

MIXS-C will be left on during the MIXS-T calibration to obtain fine detail of performance in the centre of its FOV.



		Ψ													
		(arcmin)	-30	-25	-20	-15	-10	-5	0	5	10	15	20	25	30
ϕ	30														
	25														
	20														
	15														
	10														
	5														
	0														
	-5														
	-10														
	-15														
	-20														
	-25														
	-30														

Figure 5 Angular positions for MIXS-T calibration scans in azimuth (ψ) and elevation (ϕ) of the target relative to the instrument boresight direction. Red cells represent required scans. All angles are in arcminutes.

		ψ													
		degrees	-6	-5	-4	-3	-2	-1	0	1	2	3	4	5	6
ϕ	6														
	5														
	4														
	3														
	2														
	1														
	0														
	-1														
	-2														
	-3														
	-4														
	-5														
	-6														

Figure 6 Angular positions for MIXS-C calibration scans in azimuth (ψ) and elevation (ϕ) of the target relative to the instrument boresight direction. Red cells represent required scans. All angles are in degrees.

The order in which these scans are made is not important and can be selected for convenience. The instruments should be left on during the slew between scans. There is no constraint on roll about the instrument boresight axis during the scans.



2.4.2.2 Cassiopeia A

The secondary target for on-orbit calibration of MIXS is Cassiopeia A (Cas A), a supernova remnant at 23h 23m RA, +58° 48' DEC. Cassiopeia A could be used to calibrate MIXS if the MIXS pointing plan and/or occultation by Mercury prevents calibration on the Crab, or if the sky within $\pm 10^\circ$ of the Crab is not X-ray quiet enough to characterise the MIXS-C field-of-view. Cas A was successfully used for calibration of the XRS instrument on MESSENGER.

2.4.2.3 Scorpius X-1

The tertiary target for on-orbit calibration of MIXS is Scorpius X-1 (Sco X-1), a neutron star at 16h 20m RA, -15° 38' dec. Sco X-1 is the brightest extrasolar X-ray source in the sky, but is variable on a period of ~19 hours. This means that simultaneous observation with an X-ray observatory may be necessary for MIXS calibrations from this source.

2.4.2.4 Routine calibration activities

In addition to the commanded calibration activities described above, ongoing calibration will be performed using data from routine nadir-pointing observations, which can be used to calculate gain and energy resolution of the detector. This may require minor reconfiguration of the instrument to lower the event detection threshold in order to quantify detector performance at low energy. This is simple in terms of commanding but will result in an increased TM rate for MIXS-T when compared to the nominal threshold.

2.4.3 Science data calibration

Coefficients and corrections from the calibration activities described in Sections 2.4.1 and 2.4.2, along with solar X-ray spectra from SIXS and other MIXS calibration inputs summarised in Table 5, are used in the pipeline for calibrations applied to raw science data. Calibration is handled by the RAW2CAL pipeline processing step (§3.3.2).

Product	Use in calibration activities
Offset table	Black level correction
Detector image	If detector images are required for calibration purposes, they are requested by TC. Used only for diagnostic purposes
Applicable SIXS spectrum	The SIXS solar X-ray spectrum produced at the same time as the applicable MIXS spectrum is required to properly calculate relative intensities of fluorescence lines
Gain table (MIXS-C)	Corrects for MIXS-C gain per pixel
Gain coefficients table (MIXS-C)	Adjusts gain table for temperature effects
Gain table and gain coefficients table (MIXS-T)	Corrects for MIXS-T gain per pixel; MIXS-T gain is corrected on ground and the gain and gain coefficients tables are not telemetered products.



Black level pixel lists	MIXS can report detector black levels by changing a register setting. The resulting pixel list products are used as calibration inputs. This is conducted if deemed necessary and is not a routine calibration product.
Temperature (header information)	Detector temperature is reported in pixel list and histogram header information
SPICE kernels	Frame transformations, geometry and calibration from detector to surface coordinates
Vignetting function	Gives the effective area per pixel

*Table 5 MIXS calibration inputs used in pipeline calibration activities; inputs listed in **bold** are MIXS telemetry products available in MIXS data collections (see Section 4.5.1)*

In the RAW2CAL processing step, pixel event lists are calibrated from integer DN amplitudes to floating-point energy values in eV. Histograms are converted from 256-element arrays of amplitudes to 2×256-element arrays containing calibrated bin energies and calibrated amplitudes.

Pixel amplitude to energy conversions are achieved per pixel (i.e. gain and offset can vary over the detector). This stage of the calibration process takes as inputs black levels (in telemetered HK reports and black level reports), gain and offset tables (also in telemetry), and ground reference data (gain and temperature coefficient maps).

Histogram bins are assigned using an energy-based algorithm based on the same gain and offset tables. Energy values are reconstructed on ground by reversing the calculation applied by this algorithm. Note that the topmost histogram bin will have an unbounded upper energy limit and will contain all events with an energy higher than the nominal histogram range.

Information telemetered in detector coordinates (i.e. the X- and Y- coordinates of events in pixel lists) is converted to Mercury surface coordinates (latitude and longitude). The list in (D_x, D_y, E) is converted into latitude and longitude and contains a list of events bounded in space by the instrument footprint. When the instrument's FOV is partially or entirely off the planet's surface, these coordinates are where relevant instead converted into celestial coordinates (right ascension and declination).

At the CAL2DER step, the SIXS spectra obtained simultaneously with the products under calibration, which are required to generate reliable elemental abundance ratios, are taken as an input. These will then be used to fit a solar spectrum; this is in turn used as an input to STATEX, an in house fluorescence forward model which fits the MIXS spectrum and generates the abundance ratios using a Markov Chain Monte Carlo (MCMC) algorithm. SIXS science products are described in the SIXS equivalent of this document [RD.14].



3 DATA GENERATION AND ANALYSIS PROCESS

The MIXS science products are produced by the MIXS Instrument Team in cooperation with the SGS. The data generation and analysis process is described in this section, and follows the general concept for data generation, validation and archiving described in the Archiving Plan [RD.16]. The assignment of the tasks (roles and responsibilities) has been agreed upon by all parties and documented in a Data Processing Agreement [RD.04].

Science data received by the SGS from the MIXS team are made available to end users through the BepiColombo archive following the policies described in the Archiving Plan [RD.16]

3.1 Scientific Measurements

Both MIXS-T and MIXS-C measure X-ray flux from the Mercury surface. They are energy-dispersive instruments with the sensitivity and resolution to allow the detection of fluorescence lines from several rock-forming elements of interest (Na, Mg, Al, Si, P, S, K, Ca, Ti, Cr, Mn, Fe, Ni and others).

Five different science products are produced by the MIXS instrument and returned in telemetry: Pixel lists (MIXS-T/C) and histograms (MIXS-C) are produced automatically when the instrument is in SCIENCE mode, while detector images (MIXS-T/C) are produced on receipt of a specific TC.

Pixel lists and histograms are incorporated into global elemental composition maps; at this stage, the connection to a specific observation is lost. Instead existing maps are updated to include new data.

In parallel, pixel lists and histograms are used to generate magnetosphere and environment-focused products to address MIXS' particle precipitation objectives. The data drivers for these objectives are strongly divergent from the drivers for surface composition measurements – for example, time resolution becomes critical – so the pipeline is split at the CAL2DER step in order to generate these products separately.

3.1.1 Energy resolution and binning

Both MIXS-T and MIXS-C read out pixel amplitudes as 10-bit (0-1023) integers covering an energy range of approximately 0-15 keV. In order to moderate the data rate produced by the instrument, these are down-sampled to 8-bit integers before packetizing the data for return. This can be achieved by either taking the 8 most significant bits, 8 middle bits, or 8 least significant bits, which changes the effective energy range and energy resolution of the data.

At the middle 8 bit setting, if the MSB of the 10 bit amplitude is 1, the 8 bit amplitude is set to the top bin (255). At the LSB setting, if either of the two MSBs of the 10 bit amplitude is 1, the 8 bit amplitude is set to 255.

An additional setting exists where a threshold can be set, above which amplitudes are summed with this threshold, and above which amplitudes are doubled. Then, the event is telemetered as under the LSB setting. This way, effectively events below the threshold are telemetered under the LSB setting and events above it are telemetered under the middle 8 setting.



Setting	Approx. energy range (eV)	Approx. bin width (eV)
Native resolution	0-15000	15
8 LSBs	0-3750	15
Middle 8	0-7500	30
8 MSBs	0-15000	60
Variable	0-7500	Variable

Table 6 Approximate effects of MIXS amplitude downsampling settings

Since the deleted bits are not telemetered and are not known by the pipeline, this has the effect of reducing the overall energy range of the spectrum by a factor of 4 (LSBs), increasing the bin width (and thus worsening the energy resolution) by a factor of 4 (MSBs), or both reducing the energy range by a factor of 2 and increasing the bin width by a factor of 2 (middle 8). The default setting in the instrument configurations is to telemeter the 8 middle bits, producing an approximate energy range of 0-7.5 keV and a bin width of ~30 eV. The setting can be changed by telecommand if desired.

3.1.2 MIXS-T scientific measurements

MIXS-T pixel lists are comprised of observed X-ray fluorescence events from the surface of Mercury (or X-rays directly emitted by astrophysical sources). Pixel lists are the primary MIXS-T science products, and contain line-by-line events, each representing an individual X-ray detected in the instrument. Each event consists of X- and Y-coordinates of the pixel where the X-ray was detected, and a pixel amplitude ideally proportional to the energy of the X-ray. In later stages of processing, this amplitude is converted to an energy using per-pixel calibrations, and the pixel X- and Y-coordinates are converted to Mercury surface coordinates (or other coordinates of interest) using geometric calculations and SPICE kernels.

The MIXS-T detector is sensitive to X-rays from less than 500 eV to more than 7500 eV, although during operations thresholds will usually be applied and X-ray events not falling within these thresholds will not be telemetered. These thresholds may be changed in certain circumstances, for example to capture fluorescence lines of interest which would otherwise be excluded from telemetry.

MIXS-T also produces detector images upon request, which are diagnostic products containing the instantaneous amplitude of all pixels across the detector. These products are used as an input to the calibrations applied to pixel list data.

At high levels of processing, MIXS-T pixel lists will be used along with data from other instruments including SIXS to generate thematic maps of the surface and other derived products.

3.1.3 MIXS-C scientific measurements

The primary MIXS-C science products are spectral histograms, with dynamic bin widths and depths depending on the instrument configuration and observed levels of flux. Histograms are 256 bins wide (i.e. ~38 eV wide bins with a 0.3-10 keV energy window).



MIXS-C also produces pixel lists. These are identical to those produced by MIXS-T in terms of structure, but are rate-limited in order to reduce the volume of data produced. No more events than a maximum value (configurable, but 100 s⁻¹ by default) are telemetered.

Detector images can also be requested from MIXS-C by telecommand; these are similar to those produced by MIXS-T.

At high levels of processing, MIXS-C pixel lists and histograms will be used along with data from other instruments including SIXS to generate thematic maps of the surface and other derived products.

3.2 Data Flow Overview

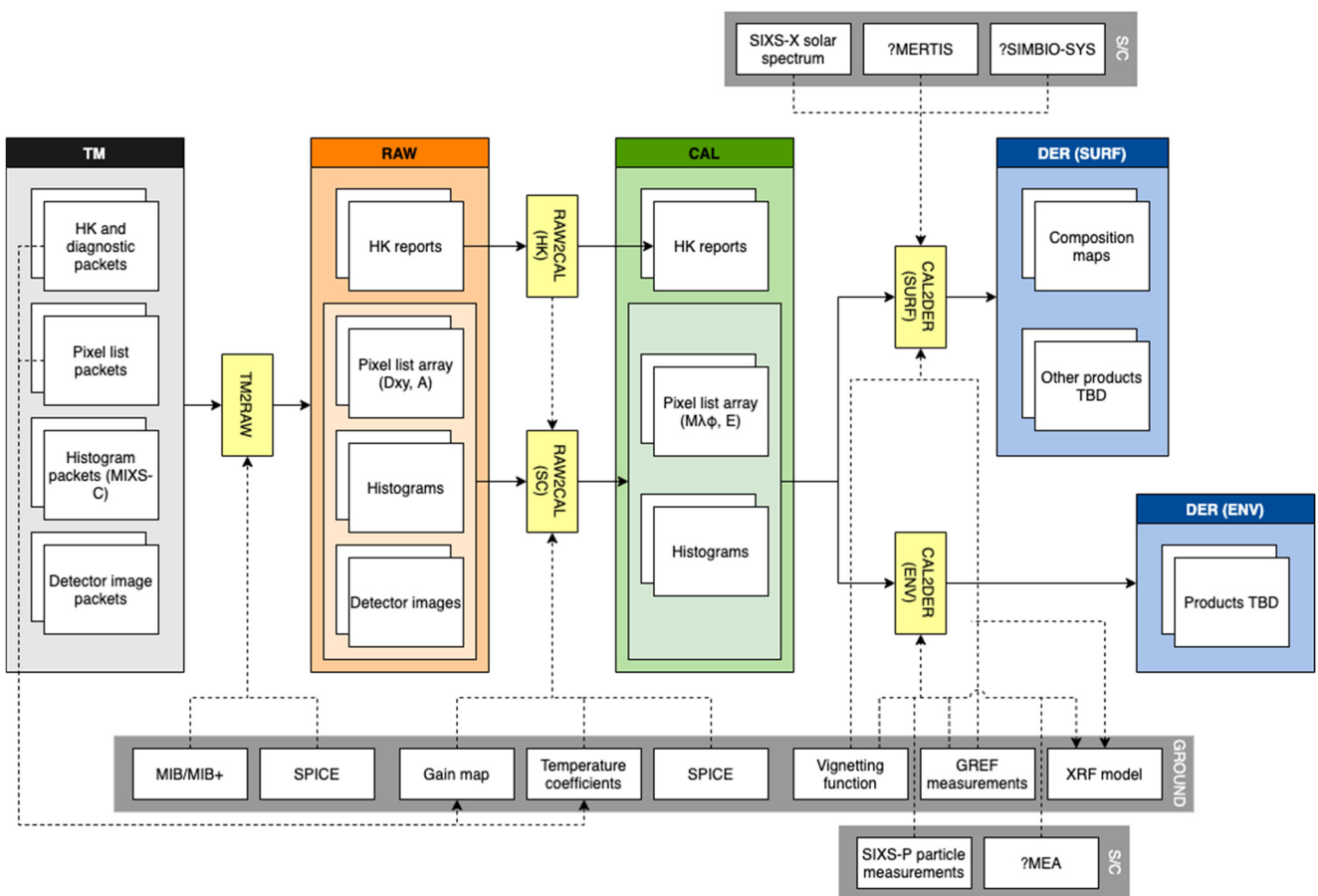

Figure 7 Block diagram of the MIXS data processing pipeline



3.3 Data Generation

The following sections describe the process by which data products in each of the steps described in section 3.5 are produced.

The detailed description of each step is currently documented in the Pipeline Description Document [RD.12]. *After the pipeline software development and testing is complete this information will be incorporated into this section.*

The products generated by each step are described in Section 5. All products are compliant with the Planetary Data System (PDS4) standards [AD.01].

3.3.1 Raw Data Generation

RAW data are produced from TM in the TM2RAW processing step. This processing step will be developed and maintained by SGS.

All MIXS science and engineering telemetry are decoded and re-assembled into HK reports (DPU, MIXS-T and MIXS-C) and self-contained (re-packed and complete) pixel lists (MIXS-T, MIXS-C), histograms (MIXS-C) and detector images (MIXS-T, MIXS-C).

Once downlinked, data products are divided up by (Earth) day of generation, using the timestamp associated with each individual packet. In the case of packets which straddle two days (i.e., the start time is during one day and the end time is during the next), the product will be placed according to the start time. Therefore the products associated with some days may include some data generated in the next day. In some cases, such as MIXS-T pixel lists, where a single product covering an entire Earth day may become prohibitively large, the IT may choose to further subdivide these products by orbit number. MPO orbits start at periapsis; if this division is used, as with division by day, data straddling two orbits will be attached to the orbit before the orbit number increase.

Embedded parameters within the science TM are extracted and stored in RAW format. At the RAW stage, all TM parameters embedded or otherwise, are stored without conversion being applied.

For each day the following housekeeping and diagnostic products are available:

- DPU HK report
- MIXS-T HK report (if MIXS-T is on)
- MIXS-C HK report (if MIXS-C is on)
- Diagnostic reports (requested tables etc)

For each day the following MIXS-T science products are available:

- MIXS-T pixel list of amplitudes (in detector coordinates Dxy)
- Conditional (by TC request): MIXS-T detector image (for diagnostics)

For each day the following MIXS-C science products are available:



- MIXS-C pixel list of amplitudes (in detector coordinates Dxy)
- MIXS-C histograms
- Conditional (by TC request): MIXS-C detector image (for diagnostics)

Pixel list science products consist of two files – the first contains timestamped header information, and the second contains the pixel lists themselves, tied to the relevant header in the first file through matching timestamps.

RAW products will be associated with geometry products, which contain geometry information correlated by time. The generation of geometry products is discussed in §3.3.4.2 below.

The TM2RAW processing step is conducted autonomously immediately after reception of the data. RAW data should be available within four hours of the retrieval of TM data from the EDDS [RD.16].

3.3.2 Calibrated Data Generation

3.3.2.1 Calibrated data generation (housekeeping)

For housekeeping data, the calibrated (CAL) data processing level is produced by the RAW2CAL data processing step. The production of calibrated housekeeping data is the responsibility of SGS.

CAL HK data products are similar to RAW data products in terms of structure, with the exception that all engineering and housekeeping parameters telemetered as digital numbers (DNs) are calibrated to engineering units as appropriate.

For each day the following housekeeping and diagnostic products are available at CAL level:

- DPU HK report
- MIXS-T HK report (if MIXS-T is on)
- MIXS-C HK report (if MIXS-C is on)
- Diagnostic reports (requested tables, TC reports etc)

3.3.2.2 Calibrated data generation (science)

Calibrated (CAL) science data products are produced from raw data products during the RAW2CAL processing step. The production of calibrated science data is the responsibility of the MIXS PI team.

CAL science products contain event locations in both surface (latitude/longitude) and detector coordinates; these latter are the same as the location information in RAW. CAL products are similar to RAW science products in terms of structure, but contain additional columns for the additional location data and a data quality flag. Energy amplitudes from RAW data are converted to energies in eV. All translations from detector coordinates to surface coordinates are accomplished using SPICE kernels and timestamp information from the data.

CAL products will be associated with geometry products, which contain geometry information correlated by time. The generation of geometry products is discussed in §3.3.4.2 below.



3.3.3 *Derived Data Generation*

Derived (DER) science data products are produced from MIXS calibrated data products and other calibrated data products including SIXS, during the CAL2DER processing step. The production of derived science data is the responsibility of the MIXS PI team.

DER science products are each tailored to a specific science goal and therefore are very diverse in terms of format and content. Products focussing on surface composition are very different from those focussing on Mercury's environment, so the CAL2DER pipeline is branched in order to avoid unnecessary reprocessing of data. Currently two branches are foreseen but additional branches can be added as necessary, since processing within any one branch is independent of others.

3.3.3.1 **Generation of DER surface and composition branch products**

The primary products of the surface branch of the CAL2DER pipeline are elemental abundance maps of various elements, covering the full globe of Mercury. Each element's abundance is specified as a ratio to that of Si (which is ubiquitous in regolith).

3.3.3.1.1 ***Generation of elemental abundance maps***

Elemental abundance maps of the Mercury surface are one of MIXS' most important science products and serve to fulfil two of its three main science objectives. A simplified description of the pipeline processes used to generate these products from CAL data follows. This pipeline is run on the complete CAL data set at TBD day intervals.

1. A spatially balanced grid of n randomly-located points is generated, covering the whole surface of the planet
2. For each grid point, a circle with initial radius $r = [\text{starting value}]$ is constructed.
3. Every event with a surface location within a distance less than r of the grid point is retrieved from the CAL data set
4. Every SIXS-X calibrated record relevant to the events in Step 3 is retrieved from the SIXS CAL data set
5. A solar model is fitted to each relevant SIXS-X spectrum, providing the required input solar spectra for analysis of the MIXS events retrieved in step 3
6. Using the in-house X-ray fluorescence model STATEX along with the fitted solar models from step 5 and the MIXS event data from step 3, a surface abundance in the relevant element is calculated along with the associated error
7. Repeat steps 2-6 for increasing radius r over a TBD range
8. The result is a series of global 3D distributions of overlapping circles each with an assigned abundance value and error, from high-resolution low-sensitivity maps with low r to low-resolution high-sensitivity maps with high r . Within every area where circles overlap, the measured abundances and errors are convolved together using inverse distance weighting.
9. The global distribution of abundance values is projected using an equirectangular projection into a 2D array with a grid size such that individual elements match the optimal foreseen MIXS resolution (i.e., 1 km at the equator). [This implies a $\sim 16000 \times 8000$ element array mapping to latitude and longitude coordinates such that $[0,0] = [0^\circ\text{E } 90^\circ\text{S}]$ and $[16000,8000] = [360^\circ\text{E } 90^\circ\text{N}]$. With single precision float values this implies a $\sim 500\text{MB}$ file size] The same is done using the calculated errors. In any



location in which the resolution of the array exceeds that of the abundance map, the same value is stored in as many adjacent array cells as required. NB this will happen much more near the poles, where the array cells will be very over-sampled due to the requirement to match optimum resolution at the equator.

Several important properties of the surface abundance maps (in particular surface cell size i.e. implicit resolution) are still under definition and will be included in a later version of this document.

3.3.3.2 Generation of DER Hermean environment branch products

Products of the environment branch of the CAL2DER pipeline are in an earlier stage of definition and development; an early concept discussed in §5.3.2 is to generate a time-energy spectrogram of precipitating particles within the planet's "auroral" zones.

3.3.4 Miscellaneous Data Generation

3.3.4.1 Calibration products generation

Products supplied for calibration purposes are classified as MISC products. They are not produced as part of the science data pipeline and are instead generated by the MIXS IT on an as-needed basis.

Description of further MISC data products will be included in a future update to this document

3.3.4.2 Geometry products generation

RAW and CAL science products are associated with geometry products containing geometry information at the same time resolution as the science data. The geometry product for any one RAW science product and its CAL counterpart is the same, because the time resolution and the associated geometry information is unchanged by the calibration process.

All geometry information are calculated using the appropriate SPICE kernels, referred to by the metakernel used, and the reference UTC times (which match the timestamps of the relevant science product). Geometry information for products from all sub-units includes:

- A Boolean flag indicating whether the boresight intersects Mercury
- Boresight intercept (lat-long or RA/DEC)
- For each FOV corner:
 - A Boolean flag indicating whether the vector defining the corner intersects Mercury
 - FOV corner intercept (lat-long or RA/DEC)
- Spacecraft position and velocity information (state vector)
- Phase, incidence and emission angles

Each of these geometry parameters is given on the same time resolution as the data in the associated product. Typically this is 3 s resolution for pixel lists, 10 s resolution for histograms and 64 s for housekeeping products.



If the boresight or FOV corners do not intercept the surface, the relevant information will be replaced by the right ascension and declination of the intercept with the celestial sphere.

The product header will also specify the SPICE metakernel version used to generate the geometry metadata.

3.4 Validation

The following sections describe the process by which the data products are validated.

3.4.1 Instrument Team Validation

Validation processes are under definition and will be included in a future version of this document

3.4.2 Peer Review

The SGS conducted a full peer review of all of the data types that the MIXS team intends to archive in October-November 2023. The review data consisted of fully formed bundles (a top-level PDS4 data collection; see Section 4.2 for a description of the MIXS bundle) populated with candidate final versions of the data and other products and the associated metadata along with accompanying documentation.

To be completed in the next version of this template.

3.5 Data Delivery Schedule

Table 7 summarises the data delivery schedule, defined in [RD.16].

Deliverables	Schedule	Reference
TM	Immediately after retrieval from the EDDS	
QLA	TBD	5.4.1
RAW	TM + 4 hours	5.1
CAL	RAW+ 1 week	5.2
DER	When generated	5.3

Table 7: List of deliverables with corresponding delivery schedule (to SGS)



4 DATA ORGANISATION AND CONTENTS

This section describes the basic organization of the MIXS bundle, and the naming conventions used for the products, collections and bundle, collection, and basic product filenames.

4.1 Format and Conventions

Proposed content and structure will be included in the next version of the template.

4.2 Bundle Content and Structure

MIXS data are archived as PDS4-compliant products within a single bundle containing all science and auxiliary data. This bundle is subdivided into data collections for each of the MIXS processing levels (RAW, CAL and DER) as well as collections for auxiliary information (documentation, SPICE kernels, etc.). These collections in turn contain subdirectories dividing information by mission phase and data types. The structure of the MIXS bundle is summarised in Section 4.5.1.

MIXS data are compliant with PDS4, making use of the geometry (geom:), PSA (psa:) and BepiColombo (bc:) data dictionaries. It is possible that an instrument-specific data dictionary will be added in the future.

4.3 Logical Identifier Formation

PDS4 Logical Identifiers (LID) for MIXS products are generated as follows. Note that all LIDs can be appended with a version identifier (VID) using a double colon at the end of the LID

`<lid>::<version_id>`

in which case the combined identifier is known as a Versioned Logical Identifier (LIDVID).

Version numbering rules are under discussion and will be included in a later version of this document.

4.3.1 Bundle LID formation

LIDs for PSA bundles are formed as

urn:esa:psa:bc_mpo_mixs

Therefore, for example, the LIDVID for the MIXS bundle, version 0.1, is

urn:esa:psa:bc_mpo_mixs::0.1

4.3.2 Collection LID formation

LIDs for MIXS collections are formed as



urn:esa:psa:<bundle_identifier>:<collection_type>_<processing_level>

where <bundle_identifier> is the bundle identifier as described in 4.3.1, <collection_type> is the collection type, which describes the contents of the collection and will be one of the MIXS collections listed in Section 4.5 and <processing_level> is the processing level of the data in the collection and must be one of {raw, calibrated, derived}. If there is no processing level (e.g. for ground calibration products), <processing_level> is omitted.

For example, the LIDVID for the MIXS RAW data collection, version 0.1, is

urn:esa:psa:bc_mpo_mixs:data_raw::0.1

4.3.3 Product LID formation

LIDs for individual MIXS products are formed as

urn:esa:psa:<bundle_identifier>:<collection_identifier>:<product_identifier>

where <bundle:identifier> and <collection_identifier> are the bundle and collection identifiers as described in 4.3.1 and 4.3.2 respectively, and <product_identifier> is replaced by

<instrument>_<processing_level>_<type>_<subunit>_<descriptor>_<YYYYMMDD>

or, if more than one product is generated in the UTC day referred to by YYYYMMDD,

<instrument>_<processing_level>_<type>_<subunit>_<descriptor>_<YYYYMMDD_NN>,

where <instrument> is {mix}, <processing_level> is {raw, cal, der} as appropriate, <type> is {sc, misc, hk, calib} as appropriate, <subunit> is {mixs-c, mixs-t, dpu} as appropriate, <descriptor> is a free text descriptor which must contain lowercase letters {a-z}, digits {0-9}, and { - _ . } only, and NN is a sequence number, starting at 00 for the first product generated each UTC day.

For example, the LIDVID for the product containing RAW MIXS-T pixel lists generated during 1st April 2027, version 0.1, is

urn:esa:psa:bc_mpo_mixs:data_raw:mix_raw_sc_mixs-t_pixel_list_20270401::0.1

If more than one pixel list product is generated during the day (see Section 3.3.1), a sequence number (reset at midnight UTC) is included for each product, for example:

urn:esa:psa:bc_mpo_mixs:data_raw:mix_raw_sc_mixs-t_pixel_list_20270401_01::0.1

4.4 Data Directory Naming Convention



The data directories presented here are speculative. Compulsory directories as defined in [RD.02] are listed in black, while optional directories are listed in blue and proposed MIXS-specific directories in red.

```

/bundle (main top-level directory)
  bundle.xml
  readme.txt
  /data_raw
    /<mission_phase>
      collection_data_raw.xml
      collection_data_raw.tab
  /data_calibrated
    /<mission_phase>
      collection_data_calibrated.xml
      collection_data_calibrated.tab
  /data_derived
    /<mission_phase>
      collection_data_derived.xml
      collection_data_derived.tab
/calibration
  /calibration_files
    collection_calibration_files.xml
    collection_calibration_files.tab
  /calibration_raw
    collection_calibration_raw.xml
    collection_calibration_raw.tab

/browse
  /browse_calibrated
    collection_browse_calibrated.xml
    collection_browse_calibrated.tab
  /browse_derived
    collection_browse_derived.xml
    collection_browse_derived.tab

/document
  collection_document.xml
  collection_document.tab
/geometry
  collection_geometry.xml
  collection_geometry.tab
/miscellaneous
  collection_miscellaneous.xml
  collection_miscellaneous.tab
/spice_kernels*
  collection_spice_kernels.xml
  collection_spice_kernels.tab
/context*
  collection_context.xml
  
```



collection_context.tab
/xml_schema*
collection_xml_schema.xml
collection_xml_schema.tab

* these collections contain only secondary members (i.e. they are links to collections elsewhere)



4.5 MIXS Science Data Organisation

The MIXS science data are archived in a single bundle, organized as follows and summarized as a hierarchical diagram in Figure 8.

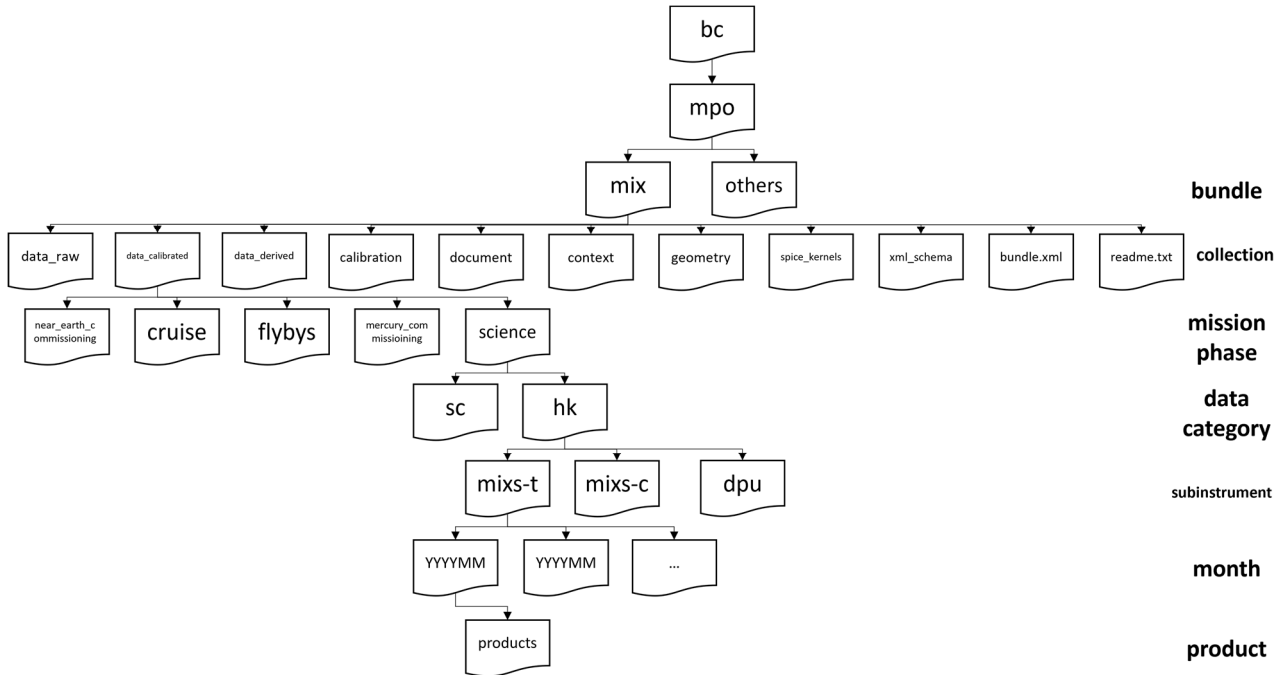

Figure 8 Hierarchical diagram of MIXS bundle subdirectory structure

4.5.1 MIXS bundle

The MIXS bundle (LID **urn:esa:psa:bc_mpo_mixs**) contains all data produced during the BepiColombo mission, from before launch to the end of the extended mission. It contains several collections as listed in Table 8. Collections marked with an asterisk are secondary collections; i.e., they are references to products elsewhere with no physical copies of the products present in the bundle.

Collection Logical ID	Description
data_raw	All data processed to RAW level (SGS)
data_calibrated	All data processed to CAL level (IT [science]/SGS [housekeeping])
data_derived	All data processed to DER level (IT)
calibration_raw	Calibration data (IT)
browse_calibrated	Calibrated product thumbnails for PSA (IT)
browse_derived	Derived product thumbnails for PSA (IT)
geometry	Geometry information associated with science products (SGS)
spice_kernels	SPICE kernels (SGS)*



document	Documentation (IT)
context	Context information (IT)*
xml_schema	XML schema (SGS from IT input)*

Table 8: Collections within the MIXS bundle

As well as these collections, the bundle contains two inventory files, **bundle_bc_mpo_mixs.lblx** and **readme_bc_mpo_mixs.txt**.

4.5.1.1 MIXS bundle RAW data collection

The MIXS RAW data collection (LID **urn:esa:psa:bc_mpo_mixs:data_raw**) contains all RAW data produced during the mission. Directory structure within this collection is as follows:

```

/data_raw
  /<mission phase>
    /sc          -science data
                  /<subinstrument>          {mixs-c, mixs-t, dpu}
                  /<YYYYMM>
                    products
                    ...
    /calib       -calibration data
                  /<subinstrument>          {mixs-c, mixs-t, dpu}
                  /<YYYYMM>
                    products
                    ...
    /hk          -housekeeping data
                  /<subinstrument>          {mixs-c, mixs-t, dpu}
                  /<YYYYMM>
                    products
                    ...
    
```

In the event of time-dependent (month) directories which would be empty, no directory will be generated.

The lowest level directories under the data_raw collection contain data products as follows:

Directory	Contents	File name convention	Section reference
sc	Science data (pixel event lists, pixel list headers, histograms)	mix_raw_sc_<subinstrument>_<data type>_<YYYYMMDD_NN>*_events#.tab	5.1.1
hk	Housekeeping reports	mix_raw_hk_<subinstrument>_<data type>_<YYYYMMDD_NN>*#.tab	5.1.3



Table 9 Data products within the **data_raw** collection

*Note that the *_NN* substring is omitted if only one product is generated in the day referred to by *YYYYMMDD*

t_events is appended to the file name of pixel event lists (see 5.1.1.1/5.1.1.3 for full description). Other file types do not have any additional text appended.

Every data product is accompanied with an XML label file with the same file name (except for the extension .lblx) containing the PDS4 label.

4.5.1.2 MIXS CAL data collection

The MIXS CAL data collection (LID **urn:esa:psa:bc_mpo_mixs:data_calibrated**) contains all CAL data produced during the mission. Directory structure within this collection is as follows:

```

/data_calibrated
  /<mission phase>
    /sc -science data
      /<subinstrument> {mixs-c, mixs-t, dpu}
        /<YYYYMM>
          products
          ...
    /calib -calibration data
      /<subinstrument> {mixs-c, mixs-t, dpu}
        /<YYYYMM>
          products
          ...
    /hk -housekeeping data
      /<subinstrument> {mixs-c, mixs-t, dpu}
        /<YYYYMM>
          products
          ...
    
```

The lowest level directories under the data_calibrated collection contain data products as follows:

Directory	Contents	File name convention	Section reference
sc	Science data (pixel event lists, pixel list headers, histograms)	mix_cal_sc_<subinstrument>_<data type>_<YYYYMMDD_NN>*_events ^t .tab	5.2
hk	Housekeeping reports	mix_cal_hk_<subinstrument>_<data type>_<YYYYMMDD_NN>*.tab	5.2.2



Table 10 Data products within the **data_calibrated** collection

*Note that the **_NN** substring is omitted if only one product is generated in the day referred to by **YYYYMMDD**

†_events is appended to the file name of pixel event lists (see 5.2.1.1/5.2.1.2 for full description). Other file types do not have any additional text appended.

4.5.1.3 MIXS DER data collection

The MIXS DER data collection (LID **urn:esa:psa:bc_mpo_mixs:data_derived**) contains all data produced at DER level during the mission. Directory structure within this collection is as follows:

```

/data_derived
  /surface
    /sc                -science data
      /subinstrument
        /<data type> {abundance_map,absolute_abundance_map}
          products
        ...
  /environment
    /sc
      /subinstrument
        /<data type> {particle_precipitation_spectrogram}
          /YYYYMM
            products
    
```

The structure of the DER data collection depends on the precise nature of DER data, which is still under definition. The structure defined here may be further updated in a future version of this document.

The lowest level directories under the **data_derived** collection contain data products as follows:

Directory	Contents	File name convention	Section reference
surface/sc	Science data (surface composition maps)	mix_der_sc_<subinstrument>_<element>_abundance_map.fff mix_der_sc_<subinstrument>_<element>_absolute_abundance_map.fff*	5.3.1
environment/sc	Science data (environmental products)	mix_der_sc_<subinstrument>_particle_precipitation_spectrogram_<YYYYMMDD_NN>.fit	5.3.2

*absolute abundance maps rely upon the ability of the instrument to quantify oxygen abundance. TBD if these products will be feasible.

<element> is the element whose abundance is given as a ratio to that of Si, or as an absolute abundance, in the relevant map. Elements with abundance map products are Mg, Al, Ca, S, K, Fe and



Na (and Si for absolute abundance maps only). If detectable and quantifiable (TBD), abundance maps for O and C may be added.

4.5.1.4 MIXS RAW calibration collection

The raw MIXS calibration collection (LID **urn:esa:psa:bc_mpo_mixs:calibration_raw**) contains all calibration products downlinked directly by the spacecraft. Directory structure within this collection is as follows:

```

/calibration_raw
  /<mission_phase>
    /sc
      /<subinstrument>           {mixs-c, mixs-t}
        /<YYYYMM>
          Products
    /hk
      /<subinstrument>           {mixs-c, mixs-t}
        /<YYYYMM>
          Products
    
```

The lowest level directories under the calibration_raw collection contain data products as follows:

Directory	Contents	File name convention	Section reference
calib	Calibration data (detector images, black level reports, gain tables, offset tables)	mix_raw_calib_<subinstrument>_<data type>_<YYYYMMDD_NN>*.tab/.fit	5.1.2

4.5.1.5 MIXS DER calibration collection

The derived MIXS calibration collection (LID **urn:esa:psa:bc_mpo_mixs:calibration_der**) contains all derived products used as calibration inputs to the pipeline. Directory structure within this collection is as follows:

```

/calibration
  /<subinstrument>           {mixs-c, mixs-t}
    /<YYYYMM>
      products
    
```

The first planned calibration products are MIXS-T and MIXS-C gain map products. These are FITS files containing arrays specifying the gain map, the temperature coefficient map for gain temperature dependence, and reference temperatures.

The pipeline will also generate redistribution functions and optic response functions for MIXS-T and MIXS-C. These are FITS files containing arrays. There is one redistribution function for each of the energy binning settings described in Section 3.1.1.



The lowest level directories under the calibration_der collection contain data products as follows:

Directory	Contents	File name convention	Section reference
<subinstrument>	Gain maps, energy redistribution functions, optic response function	mix_der_calib_<subinstrument>_gain_map_<YYYYMMDD_NN>.fit mix_der_calib_<subinstrument>_8_bit_energy_redistribution_function_<YYYYMMDD_NN>.fff mix_der_calib_<subinstrument>_9_bit_energy_redistribution_function_<YYYYMMDD_NN>.fff mix_der_calib_<subinstrument>_10_bit_energy_redistribution_function_<YYYYMMDD_NN>.fff mix_der_calib_<subinstrument>_energy_response_function_<YYYYMMDD_NN>.fff	5.4.2.1

4.5.1.6 MIXS miscellaneous collection

The MIXS miscellaneous collection (LID **urn:esa:psa:bc_mpo_mixs:miscellaneous**) contains non-science and non-housekeeping event and error reports generated by the instrument. Directory structure within this collection is as follows:

```

/miscellaneous
  /instrument_events_and_configuration
    products
    
```

The lowest level directories under the miscellaneous collection contain products as follows:

Directory	Contents	File name convention	Section reference
instrument_events_and_configuration	Event and error reports, some instrument tables	mix_raw_misc_<subinstrument>_<data type>_<YYYYMMDD_NN>*.tab	

4.5.1.7 MIXS browse collection

The MIXS browse collection (LID **urn:esa:psa:bc_mpo_mixs:browse**) contains all MIXS browse products. All browse products are tied, 1:1, to a specific science product specified in the relevant labels. Directory structure within the collection matches the equivalent science product directories as closely as possible, and is as follows:

```

browse
  /browse_<processing_level> {calibrated, derived}
    /<mission phase>
    
```



/sc *-science data*
/subinstrument
 /<YYYYMM>
products
 ...

The lowest level directories under the browse collection contain data products as follows:

Directory	Contents	File name convention	Section reference
sc	Browse spectrograms	mix_browse_<processing_level>_sc_<subinstrument>_<YYMMDD_NN*>.png	5.4.1

**Note that the _NN substring is omitted if only one product is generated in the day referred to by YYYYMMDD*

4.5.1.8 MIXS geometry product collection

The MIXS geometry collection (LID **urn:esa:psa:bc:mpo_mixs:geometry**) contains all MIXS geometry products. All geometry products are tied, 1:2, to specific science products specified in the relevant labels. The same geometry product is tied to both the raw and calibrated version of each science product, as the geometry information does not change as a function of the calibration process. Directory structure within the collection matches the equivalent science product directories as closely as possible, and is as follows:

geometry
 /<mission_phase>
 /<subinstrument> {mixs-c, mixs-t}
 /<YYYYMM>
products

The lowest level directories under the geometry collection contain data products as follows:

Directory	Contents	File name convention	Section reference
	Geometry products	mix_geometry_sc_<subinstrument>_<data_type>_<YYMMDD_NN*>.dat	



4.5.1.9 MIXS SPICE kernels collection

The MIXS SPICE kernels collection (LID **urn:esa:psa:bc_mpo_mixs:spice_kernels**) will be a secondary collection (i.e. a pointer to the mission SPICE kernel collection).

4.5.1.10 MIXS documentation collection

The MIXS documentation collection (LID **urn:esa:psa:bc_mpo_mixs:document**) contains all documentation required to understand and interpret the data in the MIXS bundle. It will contain this document (the MIXS EAICD), inventory files, a calibration document and other documents TBD.

Subdirectories within this collection exist as follows:

```

/document
  /eaicd
  /<document description> OR <document set description>
  ...
  
```

4.5.1.11 MIXS context collection

The context collection (LID **urn:esa:psa:bc_mpo_mixs:context**) contains products describing the mission, spacecraft, instrument and targets. It is a secondary collection and references the master context collection, and has the same directory structure as the master context collection.

4.5.1.12 MIXS XML schema collection

The XML schema collection (LID **urn:esa:psa:bc_mpo_mixs:xml_schema**) contains all XML schema and schematron files used in the generation and validation of products. It is a secondary collection and references the master XML schema collection, and has the same directory structure as the master XML schema collection.



5 DATA PRODUCT FORMATS

MIXS data products are formatted in accordance with the PDS4 specifications (see [AD.01], [AD.02] and [AD.03]) following the rules in the BepiColombo Archiving Guide. This section provides details on the formats used for each of the products included in the MIXS science data.

This section describes the format and record structure of each of the data file types. These tables are simplified versions of the PDS4 XML product labels archived along with every product.

Where more than one spacecraft telemetry packet has contributed to the same product (i.e. more than one packet of this type has been received within one day), new data are appended to the existing product as new rows separated by <CRLF>.

5.1 Raw Data Products

5.1.1 Raw Science Data Products

Raw science data products (part of the **data_raw** collection, in the /**sc** directory) consist of MIXS-T and MIXS-C pixel lists, MIXS-C histograms and, if requested, MIXS-T and MIXS-C detector images.

5.1.1.1 MIXS-T pixel list

The RAW MIXS-T pixel list consists of two PDS products – a header product containing packet data including timestamps, (uncalibrated) temperature and count rates, and a second event product containing the science data as a list of pixel events. As there is a 1:many correlation between the packet header data in the first table and the pixel list data in the second, each pixel event is additionally labelled with a timestamp.

NB this timestamp is that of the relevant event list in telemetry; as an exact reporting time, it is over-precise with respect to the instrument's time resolution. The exact time of the pixel event itself is not recorded and could take any value bounded by the timestamp of the pixel event and the next highest timestamp in the list. Although the exact time information is lost, pixel events in pixel lists are still correctly time-ordered, i.e. where two or more pixel events are listed with the same timestamp, they are listed in chronological order of the original detection event.

At RAW level, pixel lists are given in detector coordinates (X and Y coordinates are pixel locations; the orientation of the X and Y axes is shown in Figure 2) and pixel amplitudes, a digital number between 0 and 255. This amplitude represents the energy of the event, and is calibrated to an energy at CAL level. It is an 8-bit amplitude downsampled from the 10-bit amplitude recorded by the detector; see Section 3.1.1 for a detailed description of this process. Likewise, the X- and Y- pixel coordinates are related to the position of the fluorescence event on the surface and are calibrated to surface coordinates at CAL level.

See [RD.10] for a detailed description of the MIXS-T pixel list structure in TM.

Name	Data Type	Unit	Description
TIME.UTC	ASCII_date_time.UTC	None	UTC timestamp of header
TIME.OBT	ASCII_String	None	S/C clock at header time



TIME_OFFSET	ASCII_NonNegative_Integer	DN	Time offset from packet time to header time*
THRESHOLD	ASCII_NonNegative_Integer	DN	Lower amplitude (energy) threshold for pixel events. Events with a lower amplitude are not included in the event list.
SELECTED_TEMP_SENSOR	ASCII_NonNegative_Integer	None	ID of the active temperature sensor
DETECTOR_TEMPERATURE	ASCII_NonNegative_Integer	DN	Temperature recorded by SELECTED_TEMP_SENSOR
ACC_NORMAL_COUNTS	ASCII_NonNegative_Integer	None	Number of accumulated (not thresholded) counts in event list
ACC_OVER_RANGE_COUNTS	ASCII_NonNegative_Integer	None	Number of accumulated (thresholded) counts in event list

*Table 11 Table_Character rows within MIXS-T RAW pixel list containing pixel list header data
The time offset is negative with respect to TIME_UTC and is included to allow the calculation of the original packet time (TIME_UTC – TIME_OFFSET)

Name	Data Type	Unit	Description
TIME_UTC	ASCII_date_time_UTC	None	UTC timestamp of pixel event
POSITION_X	ASCII_NonNegative_Integer	None	X-position of pixel event in detector coordinates. Position range is (0:63)
POSITION_Y	ASCII_NonNegative_Integer	None	Y-position of pixel event in detector coordinates. Position range is (0:63)
AMPLITUDE	ASCII_NonNegative_Integer	DN	Amplitude of pixel event

Table 12 Columns in Table_Character object within MIXS-T raw pixel list containing event locations and amplitudes

5.1.1.2 MIXS-T detector image

The MIXS-T detector image is a calibration and diagnostic product consisting of a snapshot of every pixel in the detector array. It is therefore a 64×64 array of pixel values, with each value representing the instantaneous amplitude recorded by that pixel. The array is row-major and pixel coordinates start at (0,0) and correspond with the detector coordinates shown in Figure 2.

The RAW MIXS-T detector image consists of a FITS file containing metadata and a number of 64x64 detector image arrays as follows:

Name	Data Type	Unit	Description
TIME_UTC	ASCII_date_time_UTC	None	UTC timestamp of packet
TIME_OBT	ASCII_String	None	S/C clock at packet time
SID	UnsignedMSB2	None	Always = 3
IMAGE_NUMBER	UnsignedMSB2	None	Number of detector image



Table 13 Columns in MIXS-T RAW detector image metadata

Name	DETECTOR_IMAGE
Data type	UnsignedMSB2
Axis 1	
Name	Y
Elements	64
Axis 2	
Name	X
Elements	64
Axis 2	
Name	AMPLITUDE
Elements	64

Table 14 Detector image extension in MIXS-T RAW detector image

Additional detector images within the same product are appended as further FITS extensions.

5.1.1.3 MIXS-C pixel list

MIXS-C pixel lists are downlinked along with MIXS-T pixel lists, but are not the primary MIXS-C science product (which are the histograms). MIXS-C pixel lists are rate-limited, so that if the event rate exceeds a certain level set by telecommand, with a default value of 100 s⁻¹, further events within each list are not telemetered.

The RAW MIXS-C pixel list consists of two PDS products – a header product containing packet data including timestamps, (uncalibrated) temperature and count rates, and an event product containing the science data as a list of pixel events. As there is a 1:many correlation between the packet header data in the first table and the pixel list data in the event file, each pixel event is additionally labelled with a timestamp.

NB this timestamp is that of the relevant event list in telemetry; as an exact reporting time, it is over-precise with respect to the instrument's time resolution. The exact time of the pixel event itself is not recorded and could take any value bounded by the timestamp of the pixel event and the next highest timestamp in the list. Although the exact time information is lost, pixel events in pixel lists are still correctly time ordered, i.e. where two or more pixel events are listed with the same timestamp, they are listed in chronological order of the original detection event.

At RAW level, pixel lists are given in detector coordinates (X and Y coordinates are pixel locations; the orientation of the X and Y axes is shown in Figure 2) and pixel amplitudes, a digital number between 0 and 255. This amplitude represents the energy of the event, and is calibrated to an energy at CAL level. It is an 8-bit amplitude downsampled from the 10-bit amplitude recorded by the detector; see Section 3.1.1 for a detailed description of this process. Likewise, the X- and Y- pixel coordinates are related to the position of the fluorescence event on the surface and are calibrated to surface coordinates at CAL level.

See [RD.10] for a detailed description of the MIXS-C pixel list structure in TM.

Name	Data Type	Unit	Description
TIME.UTC	ASCII_date_time.UTC	None	UTC timestamp of header



TIME_OBT	ASCII_String	None	S/C clock at packet time
TIME_OFFSET	ASCII_NonNegative_Integer	DN	Time offset from packet time to header time*
THRESHOLD	ASCII_NonNegative_Integer	DN	Lower amplitude (energy) threshold for pixel events. Events with a lower amplitude are not included in the event list.
SELECTED_TEMP_SENSOR	ASCII_NonNegative_Integer	None	ID of the active temperature sensor
DETECTOR_TEMPERATURE	ASCII_NonNegative_Integer	DN	Temperature recorded by SELECTED_TEMP_SENSOR
ACC_NORMAL_COUNTS	ASCII_NonNegative_Integer	None	Number of accumulated (not thresholded) counts in event list
ACC_OVER_RANGE_COUNTS	ASCII_NonNegative_Integer	None	Number of accumulated (thresholded) counts in event list

Table 15 Columns in MIXS-C RAW pixel list header file. *The time offset is negative with respect to TIME_UTC and is included to allow the calculation of the original packet time (TIME_UTC – TIME_OFFSET)

Name	Data Type	Unit	Description
TIME_UTC	ASCII_date_time_UTC	None	UTC timestamp of pixel event
POSITION_X	ASCII_NonNegative_Integer	None	X-position of pixel event in detector coordinates
POSITION_Y	ASCII_NonNegative_Integer	None	Y-position of pixel event in detector coordinates
AMPLITUDE	ASCII_NonNegative_Integer	DN	Amplitude of pixel event

Table 16 Columns in MIXS-C RAW pixel list events file

5.1.1.4 MIXS-C detector image

The MIXS-C detector image is a calibration and diagnostic product consisting of a snapshot of every pixel in the detector array. It is therefore a 64×64 array of pixel values, with each value representing the instantaneous amplitude recorded by that pixel. The array is row-major and pixel coordinates start at (0,0) and correspond with the detector coordinates shown in Figure 2.

The RAW MIXS-C detector image consists of a FITS file containing metadata and a number of 64x64 detector image arrays as follows:

Name	Data Type	Unit	Description
TIME_UTC	ASCII_date_time_UTC	None	UTC timestamp of packet
TIME_OBT	ASCII_String	None	S/C clock at packet time
SID	UnsignedMSB2	None	Always = 3
IMAGE_NUMBER	UnsignedMSB2	None	Number of detector image

Table 17 Columns in MIXS-C RAW detector image metadata

Name	DETECTOR_IMAGE
Data type	UnsignedMSB2



Axis 1	
Name	Y
Elements	64
Axis 2	
Name	X
Elements	64
Axis 2	
Name	AMPLITUDE
Elements	64

Table 18 Detector image extension in MIXS-C RAW detector image

Additional detector images within the same product are appended as further FITS extensions.

5.1.1.5 MIXS-C histogram

The RAW MIXS-C histogram consists of a single Table_Delimited with columns as follows:

Name	Data Type	Unit	Description
TIME.UTC	ASCII_date_time.UTC	None	UTC timestamp of histogram – this is the packet time of the histogram packet summed with the offset to the start of the histogram data (ie TIME_OFFSET below)
TIME.OBT	ASCII_String	None	S/C clock at histogram time
THRESHOLD	ASCII_NonNegative_Integer	DN	Lower amplitude (energy) threshold for pixel events. Events with a lower amplitude are not included in the histogram. NB the threshold is reported on a slower cadence than individual histograms, so this value can sometimes lag the true thresholding behaviour
SELECTED_TEMPERATURE_SENSOR	ASCII_NonNegative_Integer	DN	ID of active temperature sensor
DETECTOR_TEMPERATURE	ASCII_NonNegative_Integer	DN	Temperature of the selected sensor
TIME_OFFSET	ASCII_NonNegative_Integer	DN	Time offset from packet time to start of record
HISTOGRAM_SIZE	ASCII_NonNegative_Integer	DN	Total number of bytes in the packed histogram in TM*
HISTOGRAM	ASCII_NonNegative_Integer	DN	256 bin amplitudes with maximum value of 10 ⁶

Table 19 Columns in MIXS-C RAW histogram products

*Note that at RAW level and above all histogram bins are assigned the maximum size; this parameter refers to the size of the histogram in TM



5.1.2 Raw Calibration Data Products

Raw calibration data products (part of the **data_raw** collection, in the **/calib** directory) are those that may be used in later stages of the pipeline to contribute to the calibration of MIXS science products. All calibration products are produced upon request only. Available RAW MIXS calibration products are summarised in the table below.

See [RD.10] for a detailed description of the structure of all calibration products in TM.

Product name	Filename formation	Description
Average black level report	mix_raw_calib_<inst>_average_black_level_YYYYMMDD.xml	Produced during voltage scan activities; NOT the same as black level pixel lists
Bad pixel table	mix_raw_calib_<inst>_bad_pixel_table_YYYYMMDD.xml	Flags bad pixels in the detector arrays
Current gain table*	mix_raw_calib_mixs-c_current_gain_table_YYYYMMDD.xml	Current gain table stored in the DPU, generated from the gain coefficient table and gain correction table
Gain coefficient table*	mix_raw_calib_mixs-c_gain_coefficient_table_YYYYMMDD.xml	Contains per-pixel temperature coefficients (used together with gain correction table)
Gain correction table*	mix_raw_calib_mixs-c_gain_correction_table_YYYYMMDD.xml	Contains per-pixel gain corrections at the reference temperature (used together with gain coefficient table)
Offset table	mix_raw_calib_<inst>_offset_table_YYYYMMDD.xml	Contains snapshot of the dynamically changing per-pixel offset table stored in the FPA
Software offset table	mix_raw_calib_<inst>_sw_offset_table_YYYYMMDD.xml	Contains snapshot of the dynamically changing per-pixel offset table stored in the DPU

Table 20 Summary of available RAW level calibration data products. Products marked with * are produced by MIXS-C only; others are produced by both MIXS-T and MIXS-C

5.1.3 Raw Housekeeping Data Products

RAW housekeeping products (part of the **data_raw** collection, in the **/hk** directory) consist of instrument housekeeping reports from both MIXS-T and MIXS-C FPAs, along with the MIXS/SIXS DPU. Housekeeping reports are described in the tables below.

5.1.3.1 MIXS<-T/C> housekeeping reports

Name	Data Type	Unit	Description
TIME.UTC	ASCII_date_time.UTC	None	UTC timestamp of packet
TIME.OBT	ASCII_String	None	S/C clock at packet time
FPA_POWER_STATUS	ASCII_NonNegative_Integer	None	FPA power status flag
MIXS_<T/C>_MODE	ASCII_NonNegative_Integer	None	See Table 4



RAM_ADDRESS_REGISTER	ASCII_NonNegative_Integer	None	Address for read/write in offset table, sequencer program and image buffer at packet time
SEQUENCER_XY_REGISTER	ASCII_NonNegative_Integer	None	Address being read by the sequencer at packet time
OFFSET_XY_REGISTER	ASCII_NonNegative_Integer	None	Offset table address being read by the sequencer at packet time
DIVISORS_REGISTER	ASCII_Numeric_Base2	None	16-bit binary word containing two divisors for calculating DAC clocks and Vbias/Vdrift3 clocks respectively
CONTROL_REGISTER	ASCII_Numeric_Base2	None	16-bit binary word containing control flags
THRESHOLD_REGISTER	ASCII_NonNegative_Integer	DN	Threshold for event detection (pixel amplitude)
BLACK_LEVEL_REGISTER	ASCII_NonNegative_Integer	None	Rate at which black level events are produced (one pixel per <i>n</i> frames)
COMMAND_COUNT_REGISTER	ASCII_NonNegative_Integer	None	Number of commands received
TIMING_SIGNATURE_REGISTER	ASCII_Numeric_Base16	None	Sequencer check value – output of a checking algorithm and should always have a fixed value
V_BIAS_REGISTER	ASCII_NonNegative_Integer	DN	Detector bias voltage register value
V_DRIFT_3_REGISTER	ASCII_NonNegative_Integer	DN	Outer drift ring voltage register value
V_DRIFT_1_REGISTER	ASCII_NonNegative_Integer	DN	Inner drift ring voltage register value
V_INNER_SUBSTRATE_REGISTER	ASCII_NonNegative_Integer	DN	Inner substrate voltage register value
VOLTAGE_ENABLE_REGISTER	ASCII_NonNegative_Integer	None	4-bit word containing voltage enable flags
EN_SIGNATURE_BITS_15_4_REGISTER	ASCII_NonNegative_Integer	None	12-bit word containing signal monitoring enable flags
V_DRAIN_REGISTER	ASCII_NonNegative_Integer	DN	Detector drain voltage register value
V_CLEAR_HIGH_REGISTER	ASCII_NonNegative_Integer	DN	Clear switch high voltage register value
V_CLEAR_LOW_REGISTER	ASCII_NonNegative_Integer	DN	Clear switch low voltage register value
V_CLEAR_GATE_HIGH_REGISTER	ASCII_NonNegative_Integer	DN	Clear gate switch high voltage register value
V_CLEAR_GATE_LOW_REGISTER	ASCII_NonNegative_Integer	DN	Clear gate switch low voltage register value
V_GATE_HIGH_REGISTER	ASCII_NonNegative_Integer	DN	Gate switch high voltage register value



V_GATE_LOW_REGISTER	ASCII_NonNegative_Integer	DN	Gate switch low voltage register value
V_SOURCE_N_REGISTER	ASCII_NonNegative_Integer	DN	Register value for (along with V_BIAS_N) the DEPFET current in the N sector
V_SOURCE_S_REGISTER	ASCII_NonNegative_Integer	DN	Register value for (along with V_BIAS_S) the DEPFET current in the S sector
V_BIAS_N_REGISTER	ASCII_NonNegative_Integer	DN	Register value for (along with V_SOURCE_N) the DEPFET current in the N sector
V_BIAS_S_REGISTER	ASCII_NonNegative_Integer	DN	Register value for (along with V_SOURCE_S) the DEPFET current in the S sector
OFFSET_N_REGISTER	ASCII_NonNegative_Integer	DN	Global offset register value for the N sector
OFFSET_S_REGISTER	ASCII_NonNegative_Integer	DN	Global offset register value for the S sector
V_TEST_REGISTER	ASCII_NonNegative_Integer	DN	Asteroid test voltage register value
TEST_FREQUENCY_REGISTER	ASCII_NonNegative_Integer	DN	Asteroid test signal frequency register value
V_S_1_ANALOGUE	ASCII_NonNegative_Integer	DN	+25V input from MEB
V_S_2_ANALOGUE	ASCII_NonNegative_Integer	DN	+10V input from MEB
V_S_3_ANALOGUE	ASCII_NonNegative_Integer	DN	-7V input from MEB
V_CC_ANALOGUE	ASCII_NonNegative_Integer	DN	+3.8V input from MEB
V_DD_1_ANALOGUE	ASCII_NonNegative_Integer	DN	+2.5V FEE onboard supply
V_DD_2_ANALOGUE	ASCII_NonNegative_Integer	DN	+1.5V FEE onboard supply
V_DD_A_ANALOGUE	ASCII_NonNegative_Integer	DN	Asteroid ASIC +ve supply
V_SS_A_ANALOGUE	ASCII_NonNegative_Integer	DN	Asteroid ASIC -ve supply
V_EE_ANALOGUE	ASCII_NonNegative_Integer	DN	V_EE
V_BIAS_ANALOGUE	ASCII_NonNegative_Integer	DN	Detector bias voltage
V_DRIFT_3_ANALOGUE	ASCII_NonNegative_Integer	DN	Outer drift ring voltage
V_DRIFT_1_ANALOGUE	ASCII_NonNegative_Integer	DN	Inner drift ring voltage
V_DRAIN_ANALOGUE	ASCII_NonNegative_Integer	DN	Detector DEPFET drain voltage
V_CLEAR_HIGH_ANALOGUE	ASCII_NonNegative_Integer	DN	Clear switch high voltage
V_CLEAR_LOW_ANALOGUE	ASCII_NonNegative_Integer	DN	Clear switch low voltage
V_CLEAR_GATE_HIGH_ANALOGUE	ASCII_NonNegative_Integer	DN	Clear gate switch high voltage
V_CLEAR_GATE_LOW_ANALOGUE	ASCII_NonNegative_Integer	DN	Clear gate switch low voltage
V_GATE_HIGH_ANALOGUE	ASCII_NonNegative_Integer	DN	Gate switch high voltage
V_GATE_LOW_ANALOGUE	ASCII_NonNegative_Integer	DN	Gate switch low voltage
I_SOURCE_N_ANALOGUE	ASCII_NonNegative_Integer	DN	Pixel current, north sector
I_SOURCE_S_ANALOGUE	ASCII_NonNegative_Integer	DN	Pixel current, south sector
TEMPERATURE_N_ANALOGUE	ASCII_NonNegative_Integer	DN	FPA detector temperature, north sector



TEMPERATURE_S_ANALOGUE	ASCII_NonNegative_Integer	DN	FPA detector temperature, south sector
TEMPERATURE_I_ANALOGUE	ASCII_NonNegative_Integer	DN	FPA hybrid temperature
NORMAL_COUNT_RATE	ASCII_NonNegative_Integer	DN	Count rate when packet was generated
OVER_RANGE_COUNT_RATE	ASCII_NonNegative_Integer	DN	Over range count rate when packet was generated
PIXEL_LIST_FRACTION*	ASCII_NonNegative_Integer	DN	
OVER_RANGE_ENABLE	ASCII_NonNegative_Integer	None	Enable flag for over-range filtering
HEATER_ON_TIME	ASCII_NonNegative_Integer	DN	Time heater was on since previous HK report
CONFIG_ERROR_COUNT	ASCII_NonNegative_Integer	None	Number of FPA configuration error events (cumulative)
TIMING_ERROR_COUNT	ASCII_NonNegative_Integer	None	Number of FPA timing error events (cumulative)
RESPONSE_TIMEOUT_COUNT	ASCII_NonNegative_Integer	None	Number of FPA response timeout events (cumulative)
SPLIT_PIXEL_COUNT_RATE	ASCII_NonNegative_Integer	DN	Split pixel count rate when packet was generated
SPLIT_PIXEL_IDENTIFICATION_THRESHOLD	ASCII_NonNegative_Integer	DN	Threshold used for adjacent pixels to identify split pixel event
SPLIT_PIXEL_PROCESSING_MODE	ASCII_Numeric_Base2	None	8-bit word containing split pixel processing information
FIFO_OVERFLOW_REGISTER	ASCII_Numeric_Base2	None	8-bit word containing FIFO and parity error flags
SCIENCE_TM_PACKING_OPTION_THRESHOLD	ASCII_NonNegative_Integer	None	Defines 10-bit to 8-bit pixel event amplitude sampling (§3.1.1)

Table 21 Columns in MIXS-T/C RAW housekeeping report products; field marked with * is not included in the MIXS-T report

5.1.3.2 MIXS/SIXS DPU housekeeping report

The DPU housekeeping report is produced by the DPU when it is in any mode other than OFF. Note that the same report is also the basis of a SIXS product, described in [RD.14].

Name	Location	Data Type	Unit	Description
TIME.UTC	1	ASCII_date_time.UTC	None	UTC timestamp of packet
TIME.OBT	26	ASCII_String	None	S/C clock at packet time
SSC	45	ASCII_NonNegative_Integer	None	Source sequence count of packet
DPU_MODE	51	ASCII_NonNegative_Integer	None	See Table 4
SIXS_X_MODE	53	ASCII_NonNegative_Integer	None	See [RD.14]



SIXS_P_MODE	55	ASCII_NonNegative_Integer	None	See [RD.14]
MIXS_C_MODE	57	ASCII_NonNegative_Integer	None	See Table 4
MIXS_T_MODE	59	ASCII_NonNegative_Integer	None	See Table 4
EDAC_1_BIT_ERROR_COUNT	61	ASCII_NonNegative_Integer	None	
SPACEWIRE_POINTER_WORD	72	ASCII_Numeric_Base2	None	8-bit binary word containing SpaceWire pointer information
SPACEWIRE_STATUS_WORD	81	ASCII_Numeric_Base2	None	8-bit binary word containing SpaceWire status flags
CALIBRATION	90	ASCII_NonNegative_Integer	None	
MIXS_C_TEMPERATURE_1	96	ASCII_NonNegative_Integer	DN	Temperature of thermistor A (Section 2.2 gives thermistor locations)
MIXS_C_TEMPERATURE_2	102	ASCII_NonNegative_Integer	DN	Temperature of thermistor B
MIXS_C_TEMPERATURE_4	108	ASCII_NonNegative_Integer	DN	Temperature of thermistor D
MIXS_T_TEMPERATURE_1	114	ASCII_NonNegative_Integer	DN	Temperature of thermistor E
MIXS_T_TEMPERATURE_2	120	ASCII_NonNegative_Integer	DN	Temperature of thermistor F
MIXS_T_TEMPERATURE_3	126	ASCII_NonNegative_Integer	DN	Temperature of thermistor G
MIXS_C_CF_TEMPERATURE	132	ASCII_NonNegative_Integer	DN	Temperature of thermistor K
MIXS_T_CF_TEMPERATURE	138	ASCII_NonNegative_Integer	DN	Temperature of thermistor L
DPU_TEMPERATURE_1	144	ASCII_NonNegative_Integer	DN	Temperature of thermistor A (DPU CPU)
DPU_TEMPERATURE_2	150	ASCII_NonNegative_Integer	DN	Temperature of thermistor B (DPU EEPROM)
MIXS_C_VDD	156	ASCII_NonNegative_Integer	DN	FEE supply voltage
MIXS_C_VSS	166	ASCII_NonNegative_Integer	DN	FEE supply voltage
MIXS_C_VCC	168	ASCII_NonNegative_Integer	DN	FEE supply voltage
MIXS_T_VDD	174	ASCII_NonNegative_Integer	DN	FEE supply voltage
MIXS_T_VSS	180	ASCII_NonNegative_Integer	DN	FEE supply voltage
MIXS_T_VCC	186	ASCII_NonNegative_Integer	DN	FEE supply voltage
SIXS_P_VDD	192	ASCII_NonNegative_Integer	DN	Supply voltage
SIXS_P_VSS	198	ASCII_NonNegative_Integer	DN	Supply voltage
SIXS_P_VCC	204	ASCII_NonNegative_Integer	DN	Supply voltage
SIXS_X_VDD	210	ASCII_NonNegative_Integer	DN	Supply voltage
SIXS_X_VSS	216	ASCII_NonNegative_Integer	DN	Supply voltage
SIXS_X_VCC	222	ASCII_NonNegative_Integer	DN	Supply voltage
PSU_TEMPERATURE_1	228	ASCII_NonNegative_Integer	DN	

Table 22 Columns in MIXS/SIXS DPU RAW housekeeping report products

Additional housekeeping reports in the same product are appended to the existing table as new rows (i.e. separated by <CRLF>)

5.2 Calibrated Data Products

Calibrated science data products (part of the **data_calibrated** collection, in the /sc directory) consist of MIXS-T and MIXS-C pixel lists, and MIXS-C histograms. All CAL data products are generated from the



corresponding RAW product and the relevant gain map (which is also archived as a calibration product). The pipeline also makes use of SPICE kernel information and the SPICE toolkit. The PDS label contains references to the RAW products, calibration products, and SPICE kernels used.

5.2.1 Calibrated Science Data Products

5.2.1.1 CAL MIXS-T pixel list

The CAL MIXS-T pixel list consists of two PDS products – a header product containing packet data including timestamps, temperatures and count rates, and an event product containing the science data as a list of pixel events. As there is a 1:many correlation between the packet header data in the first table and the pixel list data in the event file, each pixel event is additionally labelled with a timestamp.

At CAL level, pixel lists are given in surface coordinates (latitude and longitude; the zero datum from which longitude is measured is that given by the IAU definition [RD.17], but converse to the IAU definition is measured positive eastward). If at the timestamp of a reported pixel event the boresight of the reporting pixel is off the planet's surface, the location of the event is instead a location on the celestial sphere given in right ascension (RA) and declination (dec).

Pixel event energies are specified in electronvolts (eV).

All CAL science data products are generated from the corresponding RAW science data products, and contain a link to the specific RAW data product and calibration files that were used in their generation.

See [RD.10] for a detailed description of the MIXS-T pixel list structure in TM.

Name	Data Type	Unit	Description
TIME.UTC	ASCII_date_time.UTC	None	UTC timestamp of packet
TIME.OBT	ASCII_String	None	S/C clock at packet time
TIME.OFFSET	ASCII_Real	seconds	Time offset from packet to start of record
THRESHOLD	ASCII_NonNegative_Integer	DN	
SELECTED_TEMP_SENSOR	ASCII_String	None	ID of the active temperature sensor
DETECTOR_TEMPERATURE	ASCII_Real	degC	Temperature recorded by SELECTED_TEMP_SENSOR
ACC_NORMAL_COUNTS	ASCII_NonNegative_Integer	None	Number of accumulated (not thresholded) counts
ACC_OVER_RANGE_COUNTS	ASCII_NonNegative_Integer	None	Number of accumulated (thresholded) counts

Table 23 Columns in Table_Character objects within MIXS-T CAL pixel list containing pixel list header data

Name	Data Type	Unit	Description
TIME.UTC	ASCII_date_time.UTC	None	UTC timestamp of pixel event



DETECTOR_POSITION_X	ASCII_NonNegative_Integer	None	X position of the pixel event on the detector
DETECTOR_POSITION_Y	ASCII_NonNegative_Integer	None	Y position of the pixel event on the detector
LONGITUDE	ASCII_Real	deg	Longitude where the pixel boresight intersects the surface of the planet. If SURFACE_FLAG is FALSE, this is the right ascension where the pixel boresight intersects the celestial sphere.
LATITUDE	ASCII_Real	deg	Latitude where the pixel boresight intersects the surface of the planet. If SURFACE_FLAG is FALSE, this is the declination where the pixel boresight intersects the celestial sphere.
SURFACE_FLAG	ASCII_Boolean	None	TRUE if the pixel boresight intersects the surface of the planet, otherwise FALSE
ENERGY	ASCII_Real	eV	Energy of the pixel event
QUALITY_FLAG	ASCII_String	None	Short description of data quality established by the pipeline. Longer descriptions are given in Table 25.



Table 24 Columns in Table_Character objects within MIXS-T CAL pixel list containing event locations and energies

The QUALITY_FLAG can take several values; those defined to date are listed in Table 25.

QUALITY_FLAG	Meaning
GOOD	The pipeline detected no issues during the processing of this pixel event.
BAD_PIXEL	This pixel was identified as a bad pixel in TM. This is usually retrospective, as once a bad pixel is identified the algorithm switches off the pixel in question; when a bad pixel report is received, this flag is then applied to events reported by the relevant pixel for a duration of NNNN before the time of the bad pixel report.
TOP_BIN	This event has an uncalibrated amplitude of 255. This does not necessarily mean that the data quality is bad, but that the true energy of the event is unknown – the maximum energy of the top bin is unbounded. Furthermore, since each pixel has a different gain, top bin events can introduce a large false peak to energy spectra and it is often desirable to filter them out.
COSMIC_RAY	This event was identified by the pipeline as energy deposited in the detector by a high energy cosmic ray. The pipeline algorithmically detects and labels these events.
TOP_BIN_CR	This event was both identified by the pipeline as a cosmic ray and has an uncalibrated amplitude of 255.
CALIBRATION	This event is a Mn-K X-ray originating from the ⁵⁵ Fe calibration sources and is not a remotely sensed pixel event.

Table 25 Values of the QUALITY_FLAG field in MIXS CAL pixel lists

Additional quality flag values are under definition and will be included in future versions of this document.



5.2.1.2 CAL MIXS-C pixel list

MIXS-C pixel lists are downlinked along with MIXS-T pixel lists, but are not the primary MIXS-C science product (which are the histograms). MIXS-C pixel lists are rate-limited, so that if the event rate exceeds a certain level set by telecommand, with a default value of 100 s^{-1} , further events within each list are not telemetered.

The CAL MIXS-C pixel list consists of header metadata and two PDS objects – a Table_Character containing packet data including timestamps, temperatures and count rates, and a second Table_Character containing the science data as a list of pixel events. As there is a 1:many correlation between the packet header data in the first table and the pixel list data in the second, each pixel event is additionally labelled with a timestamp.

At CAL level, pixel lists are given in surface coordinates (latitude and longitude; the zero datum from which longitude is measured is that given by the IAU definition [RD.17], but converse to the IAU definition which is measured positive eastward) and pixel event energies specified in electronvolts (eV). Because MIXS-C cannot provide the location of individual events on sub-FOV resolution, the location of each event is given as the surface intercept of the boresight vector at the event time.

See [RD.10] for a detailed description of the MIXS-C pixel list structure in TM.

Name	Location	Data Type	Unit	Description
TIME.UTC	1	ASCII_date_time.UTC	None	UTC timestamp of packet
TIME.OBT	27	ASCII_String	None	S/C clock at packet time
TIME.OFFSET	46	ASCII_Real	seconds	Time offset from packet to start of record
THRESHOLD	54	ASCII_NonNegative_Integer	DN	
SELECTED_TEMP.SENSOR	58	ASCII_String	None	ID of the active temperature sensor
DETECTOR.TEMPERATURE	72	ASCII_Real	degC	Temperature recorded by SELECTED_TEMP.SENSOR
ACC.NORMAL.COUNTS	82	ASCII_NonNegative_Integer	None	Number of accumulated (not thresholded) counts
ACC.OVER.RANGE.COUNTS	93	ASCII_NonNegative_Integer	None	Number of accumulated (thresholded) counts

Table 26 Columns in MIXS-C CAL pixel list header file

Name	Data Type	Unit	Description
TIME.UTC	ASCII_date_time.UTC	None	UTC timestamp of pixel event
DETECTOR.POSITION.X	ASCII_NonNegative_Integer	None	X position of the pixel event on the detector
DETECTOR.POSITION.Y	ASCII_NonNegative_Integer	None	Y position of the pixel event on the detector
LONGITUDE	ASCII_Real	deg	Longitude where the instrument boresight intersects the surface of the planet. If SURFACE_FLAG is FALSE, this is the right ascension where the boresight intersects the celestial sphere.
LATITUDE	ASCII_Real	deg	Latitude where the instrument boresight intersects the surface of the planet. If SURFACE_FLAG is FALSE, this is



			the declination where the boresight intersects the celestial sphere.
SURFACE_FLAG	ASCII_Boolean	None	TRUE if the instrument boresight intersects the surface of the planet, otherwise FALSE
ENERGY	ASCII_Real	eV	Energy of the pixel event
QUALITY_FLAG	ASCII_String	None	Short description of data quality established by the pipeline. Longer descriptions are given in the MIXS-T pixel list definition in §5.2.1.1.

Table 27 Columns in MIXS-C CAL pixel list events file

5.2.1.3 MIXS-C histogram

The CAL MIXS-C histogram consists of a single Table Delimited with columns as follows:

Name	Location	Data Type	Unit	Description
TIME.UTC	1	ASCII_date_time.UTC	None	UTC timestamp of histogram – this is the packet time of the histogram packet summed with the offset to the start of the histogram data (ie TIME_OFFSET below)
TIME.OBT	26	ASCII_String	None	S/C clock at histogram time
THRESHOLD	45	ASCII_NonNegative_Integer	DN	
SELECTED_TEMPERATURE_SENSOR	49	ASCII_String	DN	ID of active temperature sensor
DETECTOR_TEMPERATURE	51	ASCII_Real	degC	Temperature of the selected sensor
TIME.OFFSET	61	ASCII_Real	seconds	Time offset from packet time to start of record
HISTOGRAM_BIN_ENERGIES	69	ASCII_Real	eV	256 bin energies; each is the bottom energy of the relevant bin. Top bin upper energy is unbounded.
HISTOGRAM_BIN_COUNTS	2373	ASCII_NonNegative_Integer	DN	256 bin amplitudes with maximum value of 10 ⁶

Table 28 Columns in MIXS-C CAL histogram products

5.2.2 Calibrated Housekeeping Products

CAL housekeeping products (part of the **data_calibrated** collection, in the /hk directory) consist of instrument housekeeping reports from both MIXS-T and MIXS-C FPAs, along with the MIXS/SIXS DPU. Housekeeping reports are described in the tables below. Calibrated housekeeping reports are similar to raw housekeeping reports, with relevant parameters calibrated to engineering units or text strings, and some parameters decomposed to their composite flags.



5.2.2.1 MIXS<-T/C> housekeeping reports

Name	Data Type	Unit	Description
TIME.UTC	ASCII_date_time.UTC	None	UTC timestamp of packet
TIME.OBT	ASCII_String	None	S/C clock at packet time
FPA_POWER_STATUS	ASCII_String	None	FPA power status flag
MIXS_<T/C>.MODE	ASCII_String	None	See Table 4
RAM_ADDRESS_REGISTER	ASCII_NonNegative_Integer	None	Address for read/write in offset table, sequencer program and image buffer at packet time
SEQUENCER_XY_REGISTER	ASCII_NonNegative_Integer	None	Address being read by the sequencer at packet time
OFFSET_XY_REGISTER	ASCII_NonNegative_Integer	None	Offset table address being read by the sequencer at packet time
DAC_DIVISOR_REGISTER	ASCII_NonNegative_Integer	None	Divisor used to calculate DAC clocks
BIAS_DIVISOR_REGISTER	ASCII_NonNegative_Integer	None	Divisor used to calculate VbiasClock and Vdrift3Clock frequencies
CONTROL_REGISTER_RUN	ASCII_String	None	Sequencer enabled/disabled
CONTROL_REGISTER_SET_RUN	ASCII_String	None	Action of RUN flag enabled/disabled
CONTROL_REGISTER_EN_CAPTURE	ASCII_String	None	Capture of raw images enabled/disabled
CONTROL_REGISTER_EN_OUTPUT	ASCII_String	None	Detector data output enabled/disabled
CONTROL_REGISTER_SET_OUTPUT	ASCII_String	None	Action of EN_OUTPUT flag enabled/disabled
THRESHOLD_REGISTER	ASCII_NonNegative_Integer	DN	Threshold for event detection (pixel amplitude)
BLACK_LEVEL_REGISTER	ASCII_NonNegative_Integer	None	Rate at which black level events are produced (one pixel per BLACK_LEVEL_REGISTER frames)
COMMAND_COUNT_REGISTER	ASCII_NonNegative_Integer	None	Number of commands received
TIMING_SIGNATURE_REGISTER	ASCII_Numeric_Base16	None	Sequencer check value – output of a checking algorithm and should always have a fixed value
V_BIAS_REGISTER	ASCII_Real	V	Detector bias voltage register value
V_DRIFT_3_REGISTER	ASCII_Real	V	Outer drift ring voltage register value
V_DRIFT_1_REGISTER	ASCII_Real	V	Inner drift ring voltage register value
V_INNER_SUBSTRATE_REGISTER	ASCII_Real	V	Inner substrate voltage register value



V_BIAS_ENABLE_REGISTER	ASCII_String	None	VbiasClock enabled/disabled
V_DRIFT_ENABLE_REGISTER	ASCII_String	None	Vdrift3Clock enabled/disabled
SWITCHER_BOOST_ENABLE_REGISTER	ASCII_String	None	Current boost in switchers enabled/disabled
EN_SIGNATURE_REGISTER_HEARTBEAT_N	ASCII_String	None	HeartbeatN signal monitoring enabled/disabled
EN_SIGNATURE_REGISTER_HEARTBEAT_S	ASCII_String	None	HeartbeatS signal monitoring enabled/disabled
EN_SIGNATURE_REGISTER_CDS_MUX_OUT_N	ASCII_String	None	CDSmuxOutN signal monitoring enabled/disabled
EN_SIGNATURE_REGISTER_CDS_MUX_OUT_S	ASCII_String	None	CDSmuxOutS signal monitoring enabled/disabled
EN_SIGNATURE_REGISTER_HEARTBEAT_NE	ASCII_String	None	HeartbeatNE signal monitoring enabled/disabled
EN_SIGNATURE_REGISTER_HEARTBEAT_NW	ASCII_String	None	HeartbeatNW signal monitoring enabled/disabled
EN_SIGNATURE_REGISTER_HEARTBEAT_SE	ASCII_String	None	HeartbeatSE signal monitoring enabled/disabled
EN_SIGNATURE_REGISTER_HEARTBEAT_SW	ASCII_String	None	HeartbeatSW signal monitoring enabled/disabled
V_DRAIN_REGISTER	ASCII_Real	V	Detector drain voltage register value
V_CLEAR_HIGH_REGISTER	ASCII_Real	V	Clear switch high voltage register value
V_CLEAR_LOW_REGISTER	ASCII_Real	V	Clear switch low voltage register value
V_CLEAR_GATE_HIGH_REGISTER	ASCII_Real	V	Clear gate switch high voltage register value
V_CLEAR_GATE_LOW_REGISTER	ASCII_Real	V	Clear gate switch low voltage register value
V_GATE_HIGH_REGISTER	ASCII_Real	V	Gate switch high voltage register value
V_GATE_LOW_REGISTER	ASCII_Real	V	Gate switch low voltage register value
V_SOURCE_N_REGISTER	ASCII_Real	V	Register value for (along with V_BIAS_N) the DEPFET current in the N sector
V_SOURCE_S_REGISTER	ASCII_Real	V	Register value for (along with V_BIAS_S) the DEPFET current in the S sector
V_BIAS_N_REGISTER	ASCII_Real	V	Register value for (along with V_SOURCE_N) the DEPFET current in the N sector
V_BIAS_S_REGISTER	ASCII_Real	V	Register value for (along with V_SOURCE_S) the DEPFET current in the S sector



OFFSET_N_REGISTER	ASCII_Real	V	Global offset register value for the N sector
OFFSET_S_REGISTER	ASCII_Real	V	Global offset register value for the S sector
V_TEST_REGISTER	ASCII_NonNegative_Integer	DN	Asteroid test voltage register value
TEST_FREQUENCY_REGISTER	ASCII_NonNegative_Integer	DN	Asteroid test signal frequency register value
V_S_1_ANALOGUE	ASCII_Real	V	+25V input from MEB
V_S_2_ANALOGUE	ASCII_Real	V	+10V input from MEB
V_S_3_ANALOGUE	ASCII_Real	V	-7V input from MEB
V_CC_ANALOGUE	ASCII_Real	V	+3.8V input from MEB
V_DD_1_ANALOGUE	ASCII_Real	V	+2.5V FEE onboard supply
V_DD_2_ANALOGUE	ASCII_Real	V	+1.5V FEE onboard supply
V_DD_A_ANALOGUE	ASCII_Real	V	CDS ASIC +ve supply
V_SS_A_ANALOGUE	ASCII_Real	V	CDS ASIC -ve supply
V_EE_ANALOGUE	ASCII_Real	V	V_EE
V_BIAS_ANALOGUE	ASCII_Real	V	Detector bias voltage
V_DRIFT_3_ANALOGUE	ASCII_Real	V	Outer drift ring voltage
V_DRIFT_1_ANALOGUE	ASCII_Real	V	Inner drift ring voltage
V_DRAIN_ANALOGUE	ASCII_Real	V	Detector DEPFET drain voltage
V_CLEAR_HIGH_ANALOGUE	ASCII_Real	V	Clear switch high voltage
V_CLEAR_LOW_ANALOGUE	ASCII_Real	V	Clear switch low voltage
V_CLEAR_GATE_HIGH_ANALOGUE	ASCII_Real	V	Clear gate switch high voltage
V_CLEAR_GATE_LOW_ANALOGUE	ASCII_Real	V	Clear gate switch low voltage
V_GATE_HIGH_ANALOGUE	ASCII_Real	V	Gate switch high voltage
V_GATE_LOW_ANALOGUE	ASCII_Real	V	Gate switch low voltage
I_SOURCE_N_ANALOGUE	ASCII_Real	mA	Pixel current, north sector
I_SOURCE_S_ANALOGUE	ASCII_Real	mA	Pixel current, south sector
TEMPERATURE_N_ANALOGUE	ASCII_Real	degC	FPA detector temperature, north sector
TEMPERATURE_S_ANALOGUE	ASCII_Real	degC	FPA detector temperature, south sector
TEMPERATURE_I_ANALOGUE	ASCII_Real	degC	FPA hybrid temperature
NORMAL_COUNT_RATE	ASCII_NonNegative_Integer	s**-1	Count rate when packet was generated
OVER_RANGE_COUNT_RATE	ASCII_NonNegative_Integer	s**-1	Over range count rate when packet was generated
PIXEL_LIST_FRACTION*	ASCII_NonNegative_Integer	DN	
OVER_RANGE_ENABLE	ASCII_String	None	Enable flag for over-range filtering
HEATER_ON_TIME	ASCII_NonNegative_Integer	s	Time heater was on since previous HK report
CONFIG_ERROR_COUNT	ASCII_NonNegative_Integer	None	Number of FPA configuration error events (cumulative)



TIMING_ERROR_COUNT	ASCII_NonNegative_Integer	None	Number of FPA timing error events (cumulative)
RESPONSE_TIMEOUT_COUNT	ASCII_NonNegative_Integer	None	Number of FPA response timeout events (cumulative)
SPLIT_PIXEL_COUNT_RATE	ASCII_NonNegative_Integer	s**-1	Split pixel count rate when packet was generated
SPLIT_PIXEL_IDENTIFICATION_THRESHOLD	ASCII_NonNegative_Integer	DN	Threshold used for adjacent pixels to identify split pixel event
SPLIT_PIXEL_PROCESSING_MODE	ASCII_NonNegative_Integer	None	Split pixel mode
PIXEL_ZERO_CONTROL	ASCII_NonNegative_Integer	None	Specifies which neighbouring pixels are zeroed when a split pixel is identified
CHARGED_PARTICLE_PROCESSING_CONTROL	ASCII_NonNegative_Integer	None	Charged particle processing control
BLACK_LEVEL_PIXEL_COMPARISON	ASCII_String	None	Threshold against which black level pixels are compared
FIFO_OVERFLOW_REGISTER	ASCII_String	None	Whether output FIFO buffer has overflowed since last reset
FIFO_PARITY_ERROR	ASCII_String	None	Whether output FIFO has had a parity error since last reset
OFFSET_TABLE_PARITY_ERROR	ASCII_String	None	Whether parity error is detected in offset table memory
IMAGE_BUFFER_PARITY_ERROR	ASCII_String	None	Whether parity error is detected in image buffer memory
NORTH_DATA_PROCESSING_PARITY_ERROR	ASCII_String	None	Whether parity error is detected in North data processing chain
SOUTH_DATA_PROCESSING_PARITY_ERROR	ASCII_String	None	Whether parity error is detected in South data processing chain
SCIENCE_TM_PACKING_OPTION_THRESHOLD	ASCII_NonNegative_Integer	None	Defines method by which pixel events are packed into records

Table 29 Columns in MIXS-T/C CAL housekeeping report products; field marked with * is not included in the MIXS-T report

5.2.2.2 MIXS/SIXS DPU housekeeping report

The DPU housekeeping report is produced by the DPU when it is in any mode other than OFF. Note that the same report is also the basis of a SIXS product, described in [RD.14].

Name	Data Type	Unit	Description
TIME.UTC	ASCII_date_time.UTC	None	UTC timestamp of packet
TIME.OBT	ASCII_String	None	S/C clock at packet time
SSC	ASCII_Non_Negative_Integer	None	Packet source sequence count
DPU_MODE	ASCII_String	None	See Table 4



SIXS_X_MODE	ASCII_String	None	
SIXS_P_MODE	ASCII_String	None	
MIXS_C_MODE	ASCII_String	None	See Table 4
MIXS_T_MODE	ASCII_String	None	See Table 4
EDAC_1_BIT_ERROR_COUNT	ASCII_NonNegative_Integer	None	
SPW_RX_SLOT_READ_POINTER	ASCII_NonNegative_Integer	None	The next slot that will be marked as read
SPW_RX_SLOT_WRITE_POINTER	ASCII_NonNegative_Integer	None	In which slot SpaceWire Rx data is currently being buffered
SPW_LINK_B_ACTIVE	ASCII_String	None	
SPW_LINK_B_SELECTED	ASCII_String	None	
SPW_LINK_A_ACTIVE	ASCII_String	None	
SPW_LINK_A_SELECTED	ASCII_String	None	
SPW_TX_BUSY	ASCII_String	None	
SPW_RX_SLOTS_FULL	ASCII_String	None	
SPW_RX_ENABLED	ASCII_String	None	
SPW_LINK_OK	ASCII_String	None	
CALIBRATION	ASCII_NonNegative_Integer	None	
MIXS_C_TEMPERATURE_1	ASCII_Real	degC	Temperature of thermistor A (Section 2.2 gives thermistor locations)
MIXS_C_TEMPERATURE_2	ASCII_Real	degC	Temperature of thermistor B
MIXS_C_TEMPERATURE_4	ASCII_Real	degC	Temperature of thermistor D
MIXS_T_TEMPERATURE_1	ASCII_Real	degC	Temperature of thermistor E
MIXS_T_TEMPERATURE_2	ASCII_Real	degC	Temperature of thermistor F
MIXS_T_TEMPERATURE_3	ASCII_Real	degC	Temperature of thermistor G
MIXS_C_CF_TEMPERATURE	ASCII_Real	degC	Temperature of thermistor K
MIXS_T_CF_TEMPERATURE	ASCII_Real	degC	Temperature of thermistor L
DPU_TEMPERATURE	ASCII_Real	degC	Temperature of thermistor A (DPU CPU)
DPU_TEMPERATURE_2	ASCII_Real	degC	Temperature of thermistor B (DPU EEPROM)
MIXS_C_VDD	ASCII_Real	V	
MIXS_C_VSS	ASCII_Real	V	
MIXS_C_VCC	ASCII_Real	V	
MIXS_T_VDD	ASCII_Real	V	
MIXS_T_VSS	ASCII_Real	V	
MIXS_T_VCC	ASCII_Real	V	
SIXS_P_VDD	ASCII_Real	V	
SIXS_P_VSS	ASCII_Real	V	
SIXS_P_VCC	ASCII_Real	V	
SIXS_X_VDD	ASCII_Real	V	
SIXS_X_VSS	ASCII_Real	V	
SIXS_X_VCC	ASCII_Real	V	
PSU_TEMPERATURE_1	ASCII_Real	degC	

Table 30 Columns in MIXS/SIXS DPU CAL housekeeping report products



Additional housekeeping reports in the same product are appended to the existing table as new rows (i.e. separated by <CRLF>)

5.3 Derived Data Products

Derived (DER) level are the highest level of data produced by the MIXS pipeline. DER products contain quantitative physical information about Mercury and its environment, derived from MIXS data along with input from the SIXS pipeline. All DER products are science products.

At the CAL2DER processing step, the MIXS pipeline splits into multiple processing branches. At this early stage of definition, two CAL2DER branches are defined, but additional ones may be added as the definition evolves.

DER products are in the early stages of definition and are subject to change in later versions of this document.

5.3.1 Derived Surface Composition Branch Products

The Surface branch of the CAL2DER processing stage produces the surface abundance maps which fulfil the first two of MIXS' primary science objectives. After this processing stage, the time of individual observations is no longer relevant (since the elemental composition of the surface is assumed to be fixed) and is not directly represented in the data.

Reliable elemental abundances can only be calculated with the use of SIXS-X solar X-ray spectra. These spectra are used to fit a solar model, which in turn provides input to a numerical model of Mercury's surface response to X-ray illumination. The surface composition of the relevant location is iteratively adjusted by the model to achieve best fit of the observed emission spectra from MIXS, given the input X-ray spectrum from SIXS-X. *As the surface is additionally under illumination by precipitating electrons, which can also produce fluorescent X-ray emission, the model will also simulate a representative electron flux at the relevant location.* Data from SIXS-P and other instruments such as MPPE-MEA may be used by the model to appropriately scale this electron flux in both intensity and energy spectrum.

This iterative fitting process is conducted for each surface cell in the maps, being updated (in the relevant cells) each time additional data are received, improving statistics. In this way the completeness of the maps will increase over the duration of the mission, and the errors associated with each element and each cell will decrease.

5.3.1.1 Mercury surface elemental abundance maps

Mercury surface elemental abundance maps are produced for multiple rock-forming elements, each of which is a product in its own right as well as forming a selectable layer in the overall abundance maps product. Elemental abundances are reported as a ratio between the abundance of the element



in question and the abundance of silicon, which is assumed to be uniform across the planet. At the current stage of development, the intended elemental abundance maps are shown in Table 31. Maps are produced separately for MIXS-T and MIXS-C to accommodate their different resolutions.

Element	Product LID
Magnesium	mix_der_sc <subinstrument>_mg_abundance_map.fff
Aluminium	mix_der_sc <subinstrument>_al_abundance_map.fff
Calcium	mix_der_sc <subinstrument>_ca_abundance_map.fff
Sulfur	mix_der_sc <subinstrument>_s_abundance_map.fff
Potassium	mix_der_sc <subinstrument>_k_abundance_map.fff
Iron	mix_der_sc <subinstrument>_fe_abundance_map.fff
Sodium	mix_der_sc <subinstrument>_na_abundance_map.fff

Table 31 MIXS DER elemental abundance map products

Two specific further elements of interest, oxygen and carbon, are potentially detectable by MIXS and will be processed to DER level elemental abundance maps if feasible given the quality of returned MIXS data. As there are many unpredictable factors which influence whether these elements will be detectable with sufficient confidence to produce maps, the existence of these products will be TBC until well into the primary mission.

Furthermore, maps may also be produced for several elements with low expected abundances and/or high fluorescence energies; these products are contingent on the statistics obtainable at the relevant emission lines during the Mercury science mission.

These provisional products are listed in Table 32.

Element	Product LID
Oxygen	mix_der_sc <subinstrument>_o_abundance_map.fff
Carbon	mix_der_sc <subinstrument>_c_abundance_map.fff
Chromium	mix_der_sc <subinstrument>_cr_abundance_map.fff
Titanium	mix_der_sc <subinstrument>_ti_abundance_map.fff
Manganese	mix_der_sc <subinstrument>_mn_abundance_map.fff
Phosphorus	mix_der_sc <subinstrument>_p_abundance_map.fff
Chlorine	mix_der_sc <subinstrument>_cl_abundance_map.fff
Nickel	mix_der_sc <subinstrument>_ni_abundance_map.fff

Table 32 Additional MIXS DER elemental abundance maps (existence TBC)

All elemental abundance maps, for both subinstruments, share the same structure. They contain $2\ m \times n$ arrays, where m and n depend upon the resolution of the map in question; this depends upon both the element and the subinstrument. The two arrays respectively contain the elemental abundances and the associated error, which is dependent on the spatial bin defined by m and n . Both arrays are PDS type Array_2D_Map.

Specific error definition is TBD and will depend on the method used by the pipeline to generate the abundance maps.



Since these products are in effect rectangular map projections, the size of each bin varies based on latitude. Bin size (deg×deg) is assigned to match spatial (km×km) resolution at the equator and is therefore oversampled towards the poles, causing errors to increase poleward.

Name	MIXS-[T/C] [<element>] ABUNDANCE MAP
Data type	IEEE754MSBSingle
Axis 1	
Name	LATITUDE
Elements	<i>m</i>
Axis 2	
Name	LONGITUDE
Elements	<i>n</i>

Name	MIXS-[T/C] [<element>] ABUNDANCE ERROR MAP
Data type	IEEE754MSBSingle
Axis 1	
Name	LATITUDE
Elements	<i>m</i>
Axis 2	
Name	LONGITUDE
Elements	<i>n</i>

Table 33 Structure of (top) MIXS abundance maps and (bottom) abundance error maps

All elemental abundance maps share the same structure, although as noted above the size of latitude and longitude bins will depend upon the element in question.

5.3.1.1.1 **Projected Mercury surface elemental abundance maps**

These products are derived from identical data to the surface elemental abundance maps, but rather than using arrays with fixed latitude/longitude sizes are projected to a TBD map projection and encoded as images. Format is TBD; we consider GEOTIFF the ideal format but this is not currently supported by PDS, although it has been proposed for future updates. This product is intended primarily as an input to GIS software, and therefore such metadata as the format allows will be included.

Additional detail will be included in a future version of this document, when file format has been clarified.

5.3.1.2 **Mercury surface elemental absolute abundance maps**

If oxygen is detectable by MIXS it may additionally be possible to produce absolute abundance maps of some or all of these elements by inferring the oxidation state/stoichiometry in the regolith. The



speculative products that will be produced if this proves possible are listed in. Note that a silicon abundance map is produced in addition to maps for the other elements of interest since it is no longer required as an implied baseline for all other abundances.

These provisional products are listed in Table 34.

Element	Product LID
Silicon	mix_der_sc <subinstrument>_si_absolute_abundance_map.fff
Magnesium	mix_der_sc <subinstrument>_mg_absolute_abundance_map.fff
Aluminium	mix_der_sc <subinstrument>_al_absolute_abundance_map.fff
Calcium	mix_der_sc <subinstrument>_ca_absolute_abundance_map.fff
Sulfur	mix_der_sc <subinstrument>_s_absolute_abundance_map.fff
Potassium	mix_der_sc <subinstrument>_k_absolute_abundance_map.fff
Iron	mix_der_sc <subinstrument>_fe_absolute_abundance_map.fff
Sodium	mix_der_sc <subinstrument>_na_absolute_abundance_map.fff
Oxygen	mix_der_sc <subinstrument>_o_absolute_abundance_map.fff
Carbon*	mix_der_sc <subinstrument>_c_absolute_abundance_map.fff

Table 34 MIXS DER absolute elemental abundance maps (existence TBC). *Carbon absolute abundance map only possible if C is resolved (see above)

Structure of the absolute abundance map products is identical to that of the relative abundance map products, and likewise both the abundance map and its associated error map are PDS type Array_2D_Map.

Name	MIXS-[T/C] [<element>] ABSOLUTE ABUNDANCE MAP
Data type	IEEE754MSBSingle
Axis 1	
Name	LATITUDE
Elements	<i>m</i>
Axis 2	
Name	LONGITUDE
Elements	<i>n</i>

Name	MIXS-[T/C] [<element>] ABSOLUTE ABUNDANCE ERROR MAP
Data type	IEEE754MSBSingle
Axis 1	
Name	LATITUDE
Elements	<i>m</i>
Axis 2	
Name	LONGITUDE
Elements	<i>n</i>

Table 35 Structure of (top) MIXS absolute abundance maps and (bottom) MIXS absolute abundance error maps



Several important properties of the surface abundance maps (in particular surface cell size i.e. implicit resolution) are still under definition and will be included in a later version of this document.

5.3.1.3 Solar flare swaths

The highest spatial resolution available to MIXS users is attained by MIXS-T during intense solar X-ray flares. The increased X-ray flux and the hardening of the X-ray spectrum leads to greatly increased fluorescence emission from the surface, and in turn allows the processing pipeline to obtain statistically significant resolution of emission peaks from much smaller spatial bins.

In order to preserve these high-resolution data, solar flare swath products are generated. Generally, solar flares last of the order of 1 hour (i.e. approximately half of one MPO orbit) so these products are generated on a per-orbit basis. They contain elemental composition data over the MIXS-T ground swath, from pole to pole, for orbits on which solar X-ray flux measured by SIXS exceeds a threshold level. The level of this threshold and the method by which candidate flare swaths are identified is TBD.

As with planetary elemental abundance maps, solar flare swaths are generated for several elements, listed below.

Element	Product LID
Magnesium	mix_der_sc_mixs-t_mg_solar_flare_swath_<orbit_number>.fff
Aluminium	mix_der_sc_mixs-t_al_solar_flare_swath_<orbit_number>.fff
Calcium	mix_der_sc_mixs-t_ca_solar_flare_swath_<orbit_number>.fff
Sulfur	mix_der_sc_mixs-t_s_solar_flare_swath_<orbit_number>.fff
Potassium	mix_der_sc_mixs-t_k_solar_flare_swath_<orbit_number>.fff
Iron	mix_der_sc_mixs-t_fe_solar_flare_swath_<orbit_number>.fff
Sodium	mix_der_sc_mixs-t_na_solar_flare_swath_<orbit_number>.fff

Format and structure of this product is under definition and will be included in a future version of this document.

5.3.2 Derived Hermean Environment Branch Products

The Environment branch of the CAL2DER processing stage produces various products focussed on results which provide insights on Mercury's magnetosphere and environment, in order to fulfil the third MIXS primary science objective.

Unlike the surface branch, time information remains directly relevant, since Mercury's environment is a dynamic system varying on very short timescales. Therefore, some environment branch products will retain event timestamp information.

5.3.2.1 Precipitation Spectrograms



Precipitation spectrograms show the derived energy spectrum of precipitating particles observed through X-ray emission on the unlit surface of the planet. Production of these products are analogous to the calculation of surface abundances in reverse; the observed X-ray spectrum along with the constrained composition of the surface location are used as inputs to a fluorescence model in order to obtain the illuminating particle spectrum.

Precipitation spectrograms are two dimensional spectrograms with fixed bin sizes in both time (x-axis) and energy (y-axis). The colour index of the spectrograms is a linear function of total counts. We anticipate that given a sufficient number of elemental lines along the electron spectrum, along with improving knowledge of surface composition and ground-based modelling, it will be possible to reliably calculate the absolute flux of precipitating electrons on to the planetary surface. If this can be calculated, this product will also be created using flux rather than observed counts as the spectrogram colour index.

Axis	Name	Units	Description
X	Time	sec	X position is a linear rebinning of spectrogrammed (ie 2D histogrammed) seconds since the beginning of the pass, with a bin size of 1 second.
Y	Energy	eV	Y position is a linear rebinning of spectrogrammed (ie 2D histogrammed) energy, with a bin size of 2 eV.

Precipitation spectrograms are [TBD] files. The colour table used for indexing total counts is 8-bit grayscale, normalised to the maximum count rate/flux observed in the relevant science product.

Precipitation spectrograms are produced once per orbit; the pass begins when the instrument boresight crosses onto the unlit surface, and ends when it crosses back to the lit surface.

5.3.2.2 Long-term precipitation maps

The precipitation spectrograms described above are intended for analysis of short-term precipitation events; for a more long-term view of average precipitation location and intensity over the duration of the mission, precipitation maps are also produced.

The precipitation maps plot the intensity of precipitation as a function of location in magnetic space (magnetic local time and magnetic latitude) and in geographic solar space (local solar time and geographic latitude). The specific energy of incoming particles is unknown, but in order to induce fluorescence it must exceed the binding energy of electrons in the relevant shell of the relevant element; for example, in order to induce Si-K fluorescence, incoming electrons must have an energy of at least 1839 eV. The flux under illumination by electrons above this energy is a complex function of energy.



Thus, long-term precipitation maps are generated for observed fluorescence in several elements, and therefore several implied minimum electron energies. Since the elements in question are not isotropic across Mercury’s surface, only elements expected to be relatively ubiquitous are mapped, and the intensities of precipitation are normalised using elemental composition maps. As our knowledge of elemental composition will improve throughout the BepiColombo mission, the accuracy of this normalisation will likewise improve.

Element/shell	Minimum electron energy (eV)	Product LID
Magnesium-K	1303	mix_der_sc_<subinstrument>_mg_precipitation_map.fff
Aluminium-K	1560	mix_der_sc_<subinstrument>_al_precipitation_map.fff
Calcium-K	4039	mix_der_sc_<subinstrument>_ca_precipitation_map.fff
Iron-L	845	mix_der_sc_<subinstrument>_fe_precipitation_map.fff
Oxygen-K	543	mix_der_sc_<subinstrument>_o_precipitation_map.fff

5.3.2.3 Precipitation flux maps

Assuming that it is possible to calculate absolute flux of electrons precipitating to the surface, a long-term precipitation map will also be generated. This map will be a 3d image cube, with each surface pixel containing the average electron spectrum precipitating to the relevant (magnetic) location on the planet.

Product	Product LID
Precipitation flux map	mix_der_sc_<subinstrument>_precipitation_flux_map.fff

5.4 Supplementary Products Formats

5.4.1 Browse Products

Browse products are only produced for CAL level science products, and are produced on a 1:1 basis.

Browse images for pixel list and histogram products are two dimensional spectrograms with fixed bin sizes in both time (x-axis) and energy (y-axis). The colour index of the spectrograms is a linear function of total counts.

MIXS browse products are PNG files. The bin sizes in X and Y imply image dimensions of 5760 × 5000 pixels; this resolution is further down-sampled for thumbnail display. The colour table used for indexing total counts is 8-bit grayscale.



5.4.2

5.4.2 MIXS calibration products

5.4.2.1 MIXS calibration gain maps

These products contain the MIXS-T or MIXS-C gain and temperature coefficient maps as images within a single FITS file. The FITS file also contains the calibration reference temperatures T_{ref} . The use of these maps together to calibrate MIXS data is described in Section 2.4.1.2.

The structure of the MIXS-T and MIXS-C calibration gain map products is identical. Each product contains two FITS images, summarised below. The header of the TEMPERATURE_COEFFICIENT_MAP product contains the two uncalibrated reference temperatures T_{ref} in the FITS header.

Name	MIXS-[T/C] GAIN MAP
Data type	IEEE754MSBSSingle
Axis 1	
Name	Y
Elements	64
Axis 2	
Name	X
Elements	64

Table 36 MIXS-[T/C] gain map image extension within the MIXS-[T/C] calibration gain map product

Name	MIXS-[T/C] TEMPERATURE COEFFICIENT MAP
Data type	IEEE754MSBSSingle
Axis 1	
Name	Y
Elements	64
Axis 2	
Name	X
Elements	64

Table 37 MIXS-[T/C] temperature coefficient map image extension within the MIXS-[T/C] calibration gain map product

New versions of this product are generated whenever the relevant gain and/or temperature coefficient maps are changed.

5.4.2.2 MIXS energy redistribution function

The MIXS-T and -C energy distribution functions are large two-dimensional arrays describing the relation between bin number and incoming energy over the detector. There are three versions of the array, corresponding to 8-bit, 9-bit and 10-bit bin numbering. The first axis is 15000 elements long and corresponds to the energy of eV of a detection. The second axis is 256, 512 or 1024 elements long and corresponds to bin number, depending on 8-bit, 9-bit or 10-bit bin numbering respectively. The content of each array element is the probability that an incoming photon of the corresponding energy is assigned to the corresponding bin.



Thus, a section along the first axis gives the redistribution function for a given energy, while a section along the second axis gives the inverse function for a given bin.

The structure of the MIXS-T and MIXS-C energy redistribution function products is identical. Each product is an Array_2D object containing one single precision floating point array.

Name	MIXS-[T/C] 10-BIT ENERGY REDISTRIBUTION FUNCTION
Data type	IEEE754MSBSingle
Axis 1	
Name	ENERGY
Elements	15000
Axis 2	
Name	BIN NUMBER
Elements	1024

Table 38 MIXS 10-bit energy redistribution function array object

Name	MIXS-[T/C] 9-BIT ENERGY REDISTRIBUTION FUNCTION
Data type	IEEE754MSBSingle
Axis 1	
Name	ENERGY
Elements	15000
Axis 2	
Name	BIN NUMBER
Elements	512

Table 39 MIXS 9-bit energy redistribution function array object

Name	MIXS-[T/C] 8-BIT ENERGY REDISTRIBUTION FUNCTION
Data type	IEEE754MSBSingle
Axis 1	
Name	ENERGY
Elements	15000
Axis 2	
Name	BIN NUMBER
Elements	256

Table 40 MIXS 8-bit energy redistribution function array object

5.4.2.3 MIXS optic response

The MIXS-T and MIXS-C optic response products define the per-pixel optic response function of the instruments. At BOL, these response functions are based on ground calibrations, but will be updated after on-orbit calibration from astronomical sources.



The optic response function is a large Array_3D object describing the optic response across the detector for all relevant energies. The first two 64-element axes correspond to the X- and Y-axes of the detector, while the third axis is 15000 elements long and corresponds to the energy of a detected photon in eV. The contents of each array element give the effective area A_{eff} , in cm^2 , of the detector for a photon of energy ENERGY detected in pixel [X,Y].

The length of the third (energy) axis is TBC; 15000 is the maximum value but a lower value may be used instead

Name	MIXS-[T/C] OPTIC RESPONSE FUNCTION
Data type	IEEE754MSBSSingle
Unit	cm^{**2}
Axis 1	
Name	Y
Elements	64
Axis 2	
Name	X
Elements	64
Axis 3	
Name	ENERGY
Elements	15000

Table 41 MIXS optic response function array object

5.4.3 MIXS geometry products

MIXS geometry products contain geometry information adding context to MIXS science products. This is included in separate products rather than as metadata in the relevant science product header as the information is required on the same time resolution as the data themselves.

As such the geometry product corresponding to each science product is generated on the same time resolution, and geometry information is correlated to the relevant events in data by timestamp.

Geometry data are generated for all MIXS-T and MIXS-C pixel lists and histograms. It is applicable to both raw and calibrated data, as the time resolution and timestamps do not change as a function of the calibration process. Therefore, every geometry data product is associated with two science products.

5.4.3.1 MIXS-T pixel list geometry

This product contains geometry information for a MIXS-T pixel list science product (see 5.1.1.1 and 5.2.1.1).

Name	Data Type	Unit	Description
TIME.UTC	ASCII_date_time.UTC	None	UTC timestamp for which geometry is calculated. Matches a time in the associated MIXS-T pixel list product.
TIME.OBT	ASCII_String	None	S/C clock for which geometry is calculated. Matches an OBT in the associated MIXS-T pixel list product.



BORESIGHT_ON_PLANET	ASCII_Boolean	None	TRUE if the MIXS-T boresight intersects the surface of Mercury at time TIME_UTC; FALSE if it does not
BORESIGHT_LATITUDE	ASCII_Real	deg	Latitude of the intersection of the MIXS-T boresight with the surface of Mercury at time TIME_UTC*
BORESIGHT_LONGITUDE	ASCII_Real	deg	Longitude of the intersection of the MIXS-T boresight with the surface of Mercury at time TIME_UTC†
FOV_CORNER_1_ON_PLANET	ASCII_Boolean	None	TRUE if the vector defining the first (top left) corner of the MIXS-T FOV intersects the surface of Mercury at time TIME_UTC; FALSE if it does not
FOV_CORNER_1_LATITUDE	ASCII_Real	deg	Latitude of the intersection of the first (top left) corner of the MIXS-T FOV with the surface of Mercury at time TIME_UTC*
FOV_CORNER_1_LONGITUDE	ASCII_Real	deg	Longitude of the intersection of the first (top left) corner of the MIXS-T FOV with the surface of Mercury at time TIME_UTC†
FOV_CORNER_2_ON_PLANET	ASCII_Boolean	None	TRUE if the vector defining the second (top right) corner of the MIXS-T FOV intersects the surface of Mercury at time TIME_UTC; FALSE if it does not
FOV_CORNER_2_LATITUDE	ASCII_Real	deg	Latitude of the intersection of the second (top right) corner of the MIXS-T FOV with the surface of Mercury at time TIME_UTC*
FOV_CORNER_2_LONGITUDE	ASCII_Real	deg	Longitude of the intersection of the second (top right) corner of the MIXS-T FOV with the surface of Mercury at time TIME_UTC†
FOV_CORNER_3_ON_PLANET	ASCII_Boolean	None	TRUE if the vector defining the third (bottom right) corner of the MIXS-T FOV intersects the surface of Mercury at time TIME_UTC; FALSE if it does not
FOV_CORNER_3_LATITUDE	ASCII_Real	deg	Latitude of the intersection of the third (bottom right) corner of the MIXS-T FOV with the surface of Mercury at time TIME_UTC*
FOV_CORNER_3_LONGITUDE	ASCII_Real	deg	Longitude of the intersection of the third (bottom right) corner of the MIXS-T FOV with the surface of Mercury at time TIME_UTC†
FOV_CORNER_4_ON_PLANET	ASCII_Boolean	None	TRUE if the vector defining the fourth (bottom left) corner of the MIXS-T FOV intersects the surface of Mercury at time TIME_UTC; FALSE if it does not
FOV_CORNER_4_LATITUDE	ASCII_Real	deg	Latitude of the intersection of the fourth (bottom left) corner of the MIXS-T FOV with the surface of Mercury at time TIME_UTC*
FOV_CORNER_4_LONGITUDE	ASCII_Real	deg	Longitude of the intersection of the fourth (bottom left) corner of the MIXS-T FOV with the surface of Mercury at time TIME_UTC†
BC_STATE_VECTOR_X	ASCII_Real	km	X position component of the MPO state vector at time TIME_UTC, in the MSO reference frame
BC_STATE_VECTOR_Y	ASCII_Real	km	Y position component of the MPO state vector at time TIME_UTC, in the MSO reference frame



BC_STATE_VECTOR_Z	ASCII_Real	km	Z position component of the MPO state vector at time TIME_UTC, in the MSO reference frame
BC_STATE_VECTOR_V_X	ASCII_Real	km/s	X velocity component of the MPO state vector at time TIME_UTC, in the MSO reference frame
BC_STATE_VECTOR_V_Y	ASCII_Real	km/s	Y velocity component of the MPO state vector at time TIME_UTC, in the MSO reference frame
BC_STATE_VECTOR_V_Z	ASCII_Real	km/s	Z velocity component of the MPO state vector at time TIME_UTC, in the MSO reference frame
PHASE_ANGLE	ASCII_Real	deg	Phase angle (sun-boresight intersect-spacecraft) at time TIME_UTC
INCIDENCE_ANGLE	ASCII_Real	deg	Source incidence angle at the surface point at time TIME_UTC
EMISSION_ANGLE	ASCII_Real	deg	Emission angle at the surface point at time TIME_UTC

Table 42 Columns in MIXS-T pixel list geometry product

*if the relevant ON_PLANET Boolean flag for a latitude is TRUE, the parameter instead refers to the declination of the intersect of the relevant vector with the celestial sphere

†if the relevant ON_PLANET Boolean flag for a longitude is TRUE, the parameter instead refers to the right ascension of the intersect of the relevant vector with the celestial sphere

The definition of this product is not final and additional parameters may be added in the future

5.4.3.2 MIXS-C geometry

This product contains geometry information for a MIXS-C science product (see 5.1.1.15.1.1.3, 5.1.1.5, 5.2.1.2 and 5.2.1.3). The format of all geometry products is identical and does not change with science product type; the only difference between the geometry products is the change in time sampling, to match the correlated science product.

Name	Data Type	Unit	Description
TIME_UTC	ASCII_date_time_UTC	None	UTC timestamp for which geometry is calculated. Matches a time in the associated MIXS-C pixel list product.
TIME_OBT	ASCII_String	None	S/C clock for which geometry is calculated. Matches a OBT in the associated MIXS-C pixel list product.
BORESIGHT_ON_PLANET	ASCII_Boolean	None	TRUE if the MIXS-C boresight intersects the surface of Mercury at time TIME_UTC; FALSE if it does not
BORESIGHT_LATITUDE	ASCII_Real	deg	Latitude of the intersection of the MIXS-C boresight with the surface of Mercury at time TIME_UTC*
BORESIGHT_LONGITUDE	ASCII_Real	deg	Longitude of the intersection of the MIXS-C boresight with the surface of Mercury at time TIME_UTC†
FOV_CORNER_1_ON_PLANET	ASCII_Boolean	None	TRUE if the vector defining the first (top left) corner of the MIXS-C FOV intersects the surface of Mercury at time TIME_UTC; FALSE if it does not
FOV_CORNER_1_LATITUDE	ASCII_Real	deg	Latitude of the intersection of the first (top left) corner of the MIXS-C FOV with the surface of Mercury at time TIME_UTC*



FOV_CORNER_1_LONGITUDE	ASCII_Real	deg	Longitude of the intersection of the first (top left) corner of the MIXS-C FOV with the surface of Mercury at time TIME_UTC [†]
FOV_CORNER_2_ON_PLANET	ASCII_Boolean	None	TRUE if the vector defining the second (top right) corner of the MIXS-C FOV intersects the surface of Mercury at time TIME_UTC; FALSE if it does not
FOV_CORNER_2_LATITUDE	ASCII_Real	deg	Latitude of the intersection of the second (top right) corner of the MIXS-C FOV with the surface of Mercury at time TIME_UTC*
FOV_CORNER_2_LONGITUDE	ASCII_Real	deg	Longitude of the intersection of the second (top right) corner of the MIXS-C FOV with the surface of Mercury at time TIME_UTC [†]
FOV_CORNER_3_ON_PLANET	ASCII_Boolean	None	TRUE if the vector defining the third (bottom right) corner of the MIXS-C FOV intersects the surface of Mercury at time TIME_UTC; FALSE if it does not
FOV_CORNER_3_LATITUDE	ASCII_Real	deg	Latitude of the intersection of the third (bottom right) corner of the MIXS-C FOV with the surface of Mercury at time TIME_UTC*
FOV_CORNER_3_LONGITUDE	ASCII_Real	deg	Longitude of the intersection of the third (bottom right) corner of the MIXS-C FOV with the surface of Mercury at time TIME_UTC [†]
FOV_CORNER_4_ON_PLANET	ASCII_Boolean	None	TRUE if the vector defining the fourth (bottom left) corner of the MIXS-C FOV intersects the surface of Mercury at time TIME_UTC; FALSE if it does not
FOV_CORNER_4_LATITUDE	ASCII_Real	deg	Latitude of the intersection of the fourth (bottom left) corner of the MIXS-C FOV with the surface of Mercury at time TIME_UTC*
FOV_CORNER_4_LONGITUDE	ASCII_Real	deg	Longitude of the intersection of the fourth (bottom left) corner of the MIXS-C FOV with the surface of Mercury at time TIME_UTC [†]
BC_STATE_VECTOR_X	ASCII_Real	km	X position component of the MPO state vector at time TIME_UTC, in the MSO reference frame
BC_STATE_VECTOR_Y	ASCII_Real	km	Y position component of the MPO state vector at time TIME_UTC, in the MSO reference frame
BC_STATE_VECTOR_Z	ASCII_Real	km	Z position component of the MPO state vector at time TIME_UTC, in the MSO reference frame
BC_STATE_VECTOR_V_X	ASCII_Real	km/s	X velocity component of the MPO state vector at time TIME_UTC, in the MSO reference frame
BC_STATE_VECTOR_V_Y	ASCII_Real	km/s	Y velocity component of the MPO state vector at time TIME_UTC, in the MSO reference frame
BC_STATE_VECTOR_V_Z	ASCII_Real	km/s	Z velocity component of the MPO state vector at time TIME_UTC, in the MSO reference frame
PHASE_ANGLE	ASCII_Real	deg	Phase angle (sun-boresight intersect-spacecraft) at time TIME_UTC
INCIDENCE_ANGLE	ASCII_Real	deg	Source incidence angle at the surface point at time TIME_UTC



EMISSION_ANGLE	ASCII_Real	deg	Emission angle at the surface point at time TIME UTC
----------------	------------	-----	--

Table 43 Columns in MIXS-C pixel list geometry product

*if the relevant ON_PLANET Boolean flag for a latitude is TRUE, the parameter instead refers to the declination of the intersect of the relevant vector with the celestial sphere

†if the relevant ON_PLANET Boolean flag for a longitude is TRUE, the parameter instead refers to the right ascension of the intersect of the relevant vector with the celestial sphere



ANNEX 1: TELEMETERED TEMPERATURES AND VOLTAGES

This annex contains figures and tables describing the locations of sensors used to measure temperatures and voltages reported in MIXS housekeeping. Values of three of the temperature sensors are also reported in science products for calibration purposes; these are marked with asterisks (*).

Unit	TM location and name	Sensor as labelled in Figure 9	Location
MIXS-C	DPU housekeeping report MIXS_C_TEMPERATURE_1	MOM-C 1	MLI flange, rear face
	DPU housekeeping report MIXS_C_TEMPERATURE_2	MOM-C 2	MLI flange, rear face
	DPU housekeeping report MIXS_C_TEMPERATURE_3	MOM-C 3	MLI flange, rear face
	DPU housekeeping report MIXS_C_TEMPERATURE_4	MOM-C 4	MLI flange, rear face
	DPU housekeeping report MIXS_C_CF_TEMPERATURE	FPA-C 1	FPA: Cold Finger
	MIXS-C housekeeping report TEMPERATURE_N_ANALOGUE*		FPA: detector (N)
	MIXS-C housekeeping report TEMPERATURE_S_ANALOGUE*		FPA: detector (S)
	MIXS-C housekeeping report TEMPERATURE_I_ANALOGUE*		FPA: DPA hybrid
MIXS-T	DPU housekeeping report MIXS_T_TEMPERATURE_1	MOM-T 1	MLI flange, rear face
	DPU housekeeping report MIXS_T_TEMPERATURE_2	MOM-T 2	MLI flange, rear face
	DPU housekeeping report MIXS_T_TEMPERATURE_3	MOM-T 3	MLI flange, rear face
	DPU housekeeping report MIXS_T_TEMPERATURE_4	MOM-T 4	NOT USED
	DPU housekeeping report MIXS_T_TEMPERATURE_5	MOM-T 5	NOT USED
	DPU housekeeping report MIXS_T_TEMPERATURE_6	MOM-T 6	NOT USED
	DPU housekeeping report MIXS_T_TEMPERATURE_CF	FPA-T 1	FPA: Cold Finger
	MIXS-T housekeeping report TEMPERATURE_N_ANALOGUE*		FPA: detector
	MIXS-T housekeeping report TEMPERATURE_S_ANALOGUE*		FPA: detector
	MIXS-T housekeeping report TEMPERATURE_I_ANALOGUE*		FPA: DPA hybrid
DPU	DPU housekeeping report DPU_TEMPERATURE		CPU
	DPU housekeeping report DPU_TEMPERATURE_2		EEPROM
PSU	DPU housekeeping report PSU_TEMPERATURE_1		Centre of board
	DPU housekeeping report PSU_TEMPERATURE_2		

Table 44 MIXS temperature sensors in housekeeping reports (sensors marked * can also be telemetered in some science products)

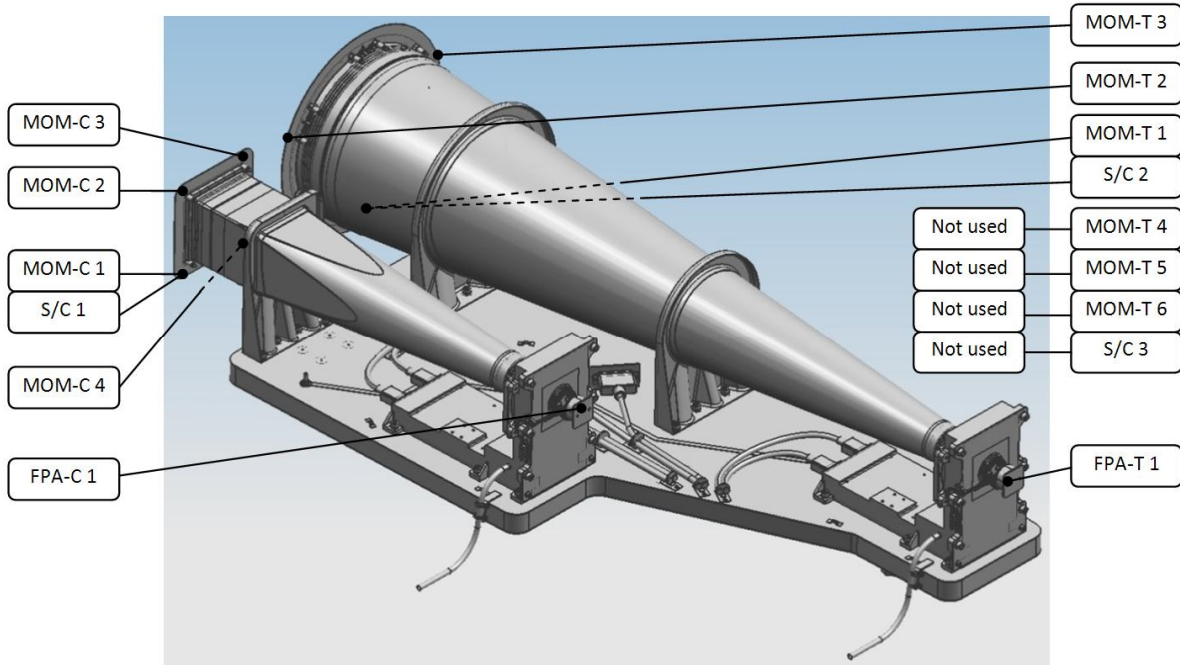

Figure 9 Schematic of MIXS with locations of thermistors providing telemetry

Voltages monitored by MIXS and reported in housekeeping reports are summarised in [RD.10]

TM location	Description
MIXS-T/C housekeeping report V_CLEAR_GATE_HIGH_ANALOGUE	Clear gate pulse high level
MIXS-T/C housekeeping report V_CLEAR_GATE_LOW_ANALOGUE	Clear gate pulse low level
MIXS-T/C housekeeping report V_GATE_HIGH_ANALOGUE	DEPFET gate high level
MIXS-T/C housekeeping report V_GATE_LOW_ANALOGUE	DEPFET gate low level
MIXS-T/C housekeeping report V_DRAIN_ANALOGUE	DEPFET drain supply
MIXS-T/C housekeeping report V_DRIFT_3_ANALOGUE	Outer drift ring bias
MIXS-T/C housekeeping report V_DRIFT_1_ANALOGUE	Inner drift ring bias
MIXS-T/C housekeeping report V_BIAS_ANALOGUE	Detector bias



MIXS-T/C housekeeping report V_SS_A_ANALOGUE	Asteroid ASIC negative supply
MIXS-T/C housekeeping report V_DD_A_ANALOGUE	Asteroid ASIC positive supply
MIXS-T/C housekeeping report I_SOURCE_S_ANALOGUE	DEPFET current* (S)
MIXS-T/C housekeeping report I_SOURCE_N_ANALOGUE	DEPFET current* (N)
MIXS-T/C housekeeping report V_CLEAR_LOW_ANALOGUE	Clear pulse low level
MIXS-T/C V_CLEAR_HIGH_ANALOGUE	Clear pulse high level
MIXS-T/C housekeeping report V_S_1_ANALOGUE	FPA power supply
MIXS-T/C housekeeping report V_S_2_ANALOGUE	FPA power supply
MIXS-T/C housekeeping report V_S_3_ANALOGUE	FPA power supply
DPU housekeeping report MIXS_C_VCC MIXS_T_VCC	FPA power supply
MIXS-T/C housekeeping report V_DD_1_ANALOGUE	FPA power supply (internal logic)
MIXS-T/C housekeeping report V_DD_2_ANALOGUE	FPA power supply (FPGA core)
DPU housekeeping report MIXS_C_VSS MIXS_T_VSS	FPA power supply (switcher negative supply)
MIXS-T/C housekeeping report V_EE_ANALOGUE	FPA power supply

Table 45 MIXS telemetered voltages

* These parameters represent currents in the detector but the value that is physically measured onboard is a voltage.

ANNEX 2: CITING MIXS DATA

Citation information is included in the header of all MIXS PSA products in the <citation_information> field.

Per the PDS4 standard ([here](#)), the most granular single product possible should be cited, i.e. if only a single data product is used, that product should be cited; if multiple products from only one collection are used, that collection should be cited; and if multiple collections from only one bundle are used, that bundle should be cited.

The citation should contain the author list (<author_list> in the header), appropriate title (<title>), publication year (<publication_year>), and doi (<doi>).



END OF DOCUMENT