

# CHANGE SUMMARY

<b>Date</b>	<b>FOP Issue</b>	<b>Version</b>	<b>Modification Description</b>	<b>Author</b>	<b>SPR Ref</b>
04/05/2011		1	Created	F. Keck	
09/08/2011		2	Update for 24/7 on-call. Adding document reference ID. Check event logs of both MCS chains.	F. Keck	
11/08/2011	3.1	3	Adding HP_SWS as cc for Pass Report Email	F. Keck	

# Herschel On-Call SOE Instructions

PT-HMOC-OPS-OM-6231-OPS-OAH

## Contents

- What's your Job?
- When is On-Call Support required?
- Standard On-Call SOE Contingency Instructions
- Herschel Contact List
- Attachments
  - SPACON Action Lists (DTCP)
  - SPACON Action Lists (POPA)
  - Herschel Pass Report Email (Template)
  - Other useful Stuff you should know
  - MTL Uplink "CRP"
  - List of FOP Procedures

# What's your Job?

---

## Tasks and Responsibilities

---

- Supervise SPACON and support SPACON if contacted
- On every day (min. 3h before the next DTCP starts, to have time to react):
  - o Check Pass Report email (even from home on non-working days)
    - E.g. problems, numbering, distribution list, strange contents, etc.
  - o If there's something to correct or additional information to add, just reply to the Pass Report email
    - Reply to all if there's an impact on the SGS
    - Reply internal for awkward issues...
- On every working day:
  - o Check POPA printouts
    - E.g. does the time range fit, strange contents, etc.
  - o Check TM consolidation
  - o Check SPACON logbook
  - o Reset SCC for P/B and H-MCS-B (R/T and P/B) if plausible
  - o Check MCS event log (on H-MCS-A and H-MCS-B) for unusual messages
    - E.g. errors which could be database issues, like OL script errors
    - E.g. fatal errors which could indicate SCOS server problems
  - o Confirm completion of your tasks by signing the SPACON logbook after the last SPACON entry of the DTCP (Monday to be signed by last SOE as final closeout)
    - E.g. "Checked. Signature"
- Emergency mission re-planning

---

## On-Call Rules

---

- On-Call period
  - o Monday to Sunday, 24/7
  - o Be always reachable via the on-call phone
- Travel time to ESOC
  - o Less than 1 hour
  - o Including means of transport available
  - o No inviolable external commitment
- Immediately contactable by mobile phone
  - o Phone must be on and have coverage
  - o Phone must be with you
- Able to drive (car and satellite)
  - o If you are over the alcohol limit to drive a car then you are over the limit to be on-call

## When is On-Call Support required?

---

### Immediate support is required when

---

- SPACON has doubts what to do
- MTL upload problems
- SVM
  - o Unexpected effect of TCs or SOIs
  - o Unexpected OOLs
  - o Unexpected (5,2) and (5,4) events
  - o Unexpected failed commands
  - o Unexpected empty packet stores
- Payload
  - o Unexpected (5,2) and (5,4) events
  - o Unexpected failed commands
  - o Unexpected triggered OBCPs

If necessary On-Call SOE must come to ESOC immediately.

---

### Support is required before next DTCP when

---

- SVM
  - o OBQD reports TCO encoding problem
  - o Unknown SVM TM packets
- Payload
  - o Unexpected OOLs
  - o Unknown Payload TM packets
- Ground Segment
  - o Failed consolidation
  - o Lost TM due to ground station problem

SPACON addresses the issue(s) in the Pass Report email, so the On-Call SOE can take actions before the next DTCP.

If the next day is not a working day the On-Call SOE must read the Pass Report email using the Mobility Pack 2. In this case the On-Call SOE has to investigate (if necessary come in to ESOC) before the next DTCP starts.

# Standard On-Call SOE Contingency Instructions

---

## HIFI Recovery (if HM049190 HI\_LCU\_commands = DISABLED)

---

SPACON will call because of OOL error HM049190 HI\_LCU\_commands = DISABLED, or because of a (5,4) event indicating a memory CRC mismatch.

Go to ESOC and run H\_CRP\_HIF\_CALL. If you cannot recover HIFI during the DTCP (i.e. expert recovery required) treat it as a severe instrument failure.

---

## SPIRE Check-sum Error

---

SPACON runs SOI-39 in every DTCP: In case of a SPIRE checksum error, SPACON will disable SPIRE subschedule and will call because of the failed SPIRE memory check TC.

Ensure SPIRE ICC is called. Go to ESOC and run H\_CRP\_SPI\_DUMP. Treat it as a severe instrument failure.

---

## Instrument is off

---

SPACON will call because of OOL/SCC errors indicating a switched off instrument.

Treat it as a severe instrument failure.

---

## Severe Instrument Failure observed in DTCP(N)

---

Classification of "Severe Instrument Failure" (to be declared by On-Call SOE or SOM):

- Instrument was switched off
- HIFI LCU SEU, which cannot be recovered during the DTCP by the On-Call SOE (i.e. expert recovery required)
- SPIRE check-sum error

### Impact on Mission Planning:

Check the mission planning of the upcoming ODs (daily emails from HSC/SwMaint)

IF

OD(N+2) foresees activities of the instrument suffering from this severe failure

THEN

- 1) Confirm to the SPACON: Do not uplink today's MTL UU part B
- 2) Contact SOM: Re-planning with HSC for OD(N+2) required

ELSE

- 1) Tell the SPACON: Uplink today's MTL UU part B
- 2) Contact SOM: Potential re-planning with HSC for upcoming ODs required

### Comment:

Provide the SPACON further MTL instructions (even if everything remains nominal, just to calm him down); i.e. if today's MTL part B was skipped, without special MTL instructions the SPACON will upload this part B tomorrow.

---

### **STR Switchover (STR-1 unhealthy, STR-2 in use)**

---

SPACON will call because of OOL/SCC errors indicating the STR switchover.

On-Call SOE to come in and check STR health: H\_FCP\_AOC\_5007

IF

SEU in STR RAM is identified by

- 21 instances of "STR initial quaternion check" TM\_5\_1\_16402 (SPID=1599109)
- Each instance separated by ~50 seconds

THEN

On-Call SOE to switch back to STR-1: H\_CRP\_AOC\_4S01

ELSE

In case of other problems, stay on STR-2, but ensure the ACMS SOE (or SOM) is informed to take action before and/or in next DTCP.

---

### **Both STRs unhealthy**

---

SPACON will call because OOL/SCC errors indicate that both STRs are unhealthy, or On-Call SOE will observe it when running a No-TM recovery and switching over to TX-2/LGA.

Go to ESOC and run H\_CRP\_SYS\_BLIND.

---

### **System Level Failure**

---

SPACON will call because of 500 bps TM rate and/or non-nominal S/C modes, combined with huge number of OOL/SSC errors.

If CDMU mode = EAM the SPACON can and shall continue with the DTCP procedure, except all MTL related stuff (MTL function is disabled); i.e. do not uplink the new MTL.

Go to ESOC and run H\_CRP\_SYS\_ANOM (which will call H\_CRP\_SYS\_CHECK). The checkout (including dumps) is essential to analyse the situation and to plan the recovery.

Ensure the SOM is informed immediately.

---

### **No-TM Recovery**

---

SPACON will call if no ground segment problem was identified (first part of H\_CRP\_SYS\_NOTM), which could have caused the No-TM situation; i.e. a S/C problem is assumed.

Go to ESOC and run H\_CRP\_SYS\_NOTM. Repeat the first (SPACON) part to ensure that there is really no ground segment problem; if confirmed, start manual TTC/DHS reconfigurations by blind commanding.

#### **Comment:**

Be aware that the unlikely case of both STR unhealthy could result in a No-TM situation at AOS; when TM is regained (the switchover to TX-2/LGA would bring TM back) the STR status can be checked.

---

### **No-TC Recovery**

---

SPACON will call if unsure how to run H\_CRP\_SYS\_NOTC or if the procedure was not successful.

Support SPACON to get a command on board or go to ESOC to run the procedure yourself.

---

## **MTL Uplink Problems**

---

SPACON will call if problems with the MTL uplink or if unsure what to do; e.g. missing TC, after an abort continued from the wrong line, duplicated TC on board, etc.

Support SPACON to get MTL complete onboard (without duplicated TCs); go to ESOC if necessary (waiting for next DTCP is not an option, we could lose the ground station).

# Herschel Contact List

Team	Email	Name	Office	Mobile
FCT	H_FCT	On-Call SOE	n/a	HFCT MOBILE (+49-170-228-3202)
SWS	HP_SWS	On-Call SWS	HPMCS SWS (+49-6151-8600541)	HPMCS MOBILE (+49-170-182-1317)
FDT	HerschelFDteam	On-Call FDT	n/a	HPFDT MOBILE (+49-170-761-1313)
HSC	hscops@sciops.esa.int	On-Call Astronomer	n/a	+34-606-565335
		On-Call Mission Planner	n/a	+34-608-794204
		Leo Metcalfe	Short dial: 70372	
		Laurence O'Rourke	Short dial: 70363	
		Pedro Garcia	Short dial: 70389	
		Anthony Marston	Short dial: 70370	
HIFI	hifi-operations@sron.nl	Russ Shipman	+31-50-363-7753	+31-653-491-676
		David Teyssier	+31-50-363-4022	+34-667-097-169
		Michael Olberg	+31-50-363-8028	+31-631-236-953
PACS	pacs_ops@sciops.esa.int	On-Call PACS (try first)	n/a	+49-160-745-6285
		Eckhard Sturm	+49-89-30-000-3806	+49-173-476-1655
		Helmut Feuchtgruber	+49-89-30-000-3290	+49-160-967-37582
SPIRE	spire@stfc.ac.uk	Tanya Lim	+44-1235-44-6558	+44-751-539-0306
		Sunil Sidher	+44-1235-44-5114	+44-793-274-2103
		Operations Room	+44-1235-44-5021	
		Fax	+44-1235-44-6667	



## SPACON Action Lists (DTCP)

### Critical Events (live or from CEL dump)

Events (5,2) & (5,4)	SVM	1) Contact On-Call SOE 2) On-Call SOE to decide: Try to contact S/S SOE 3) If instrument OBCP has triggered: Contact ICC On-Call person 4) On-Call SOE to decide: Contact SOM 5) On-Call SOE or SOM to decide: Contact FD 6) Email to H_FCT		
		PLM	HIFI	If HIFI is prime (check bus profile) contact HIFI On-Call person Add to DTCP report email. Attach screenshot of AND: ZAZ9C999
			PACS	Add to DTCP report email. Attach screenshot of AND: ZAZ98999
			SPIRE	Add to DTCP report email. Attach screenshot of AND: ZAZD4999
TC Failures (1,2) & (1,8)	SVM	Ignore SPID 11104109, no action required. For all other SVM TC failures: 1) Contact On-Call SOE 2) On-Call SOE to decide: Try to contact S/S SOE 3) On-Call SOE to decide: Contact SOM 4) On-Call SOE or SOM to decide: Contact FD 5) Email to H_FCT		
		PLM	HIFI	If HIFI is prime (check bus profile) contact HIFI On-Call person Add to DTCP report email. Attach screenshot of AND: ZAZ9C999
			PACS	Add to DTCP report email. Attach screenshot of AND: ZAZ98999
			SPIRE	If memory check TC has failed (SOI-39) contact On-Call SOE Add to DTCP report email. Attach screenshot of AND: ZAZD4999

### OOL/SCC Errors

SVM	AETF5002 or AETF6002 FCV Arm Status: SCC error		Ignore if RWL Bias or Delta-V is ongoing, else: See below "other (unexpected) OOLs"
	AEW1/2/3/4A002 RWL1/2/3/4 tacho spd: OOL error		Email to Dave Salt
	RMB01439 EPC1_ANODE_VOLT: OOL error		Ignore if it reads at AOS 1342 V for some samples, else: See below "other (unexpected) OOLs"
	WM210565 Twta_1_L49_I: OOL error		Email to Eduardo Picallo
	RMB22442 X1 Status - XS: OOL error		Ignore if XPND TM bit rate change is ongoing, else: See below "other (unexpected) OOLs"
	Other (unexpected) OOLs		1) Contact On-Call SOE 2) On-Call SOE to decide: Try to contact S/S SOE 3) On-Call SOE to decide: Contact SOM 4) On-Call SOE or SOM to decide: Contact FD 5) Email to H_FCT
PLM	HIFI	HM049190 HI_LCU_commands = DISABLED	Run H_CRP_HIF_SPCN: Procedure will help to decide if On-Call SOE must be contacted (to run H_CRP_HIF_CALL) or if an email notification is sufficient.
		Red OOLs	If HIFI is prime (check bus profile) contact HIFI On-Call person Add to DTCP report email.
		All other OOLs	Add to DTCP report email.
	PACS	All OOLs	Add to DTCP report email.
	SPIRE	All OOLs	Add to DTCP report email.

# SPACON Action Lists (POPA)

## POPA Printouts

Unknown Packets H_ODxxxx_UNK	<ol style="list-style-type: none"> <li>1) Add info to DTCP report email.</li> <li>2) On-Call SOE to investigate before next DTCP</li> </ol> <p>Be aware that unknown packets are treated by the MCS like missing packets; therefore TM consolidation will fail as well.</p>
Event Packets H_ODxxxx_EVT	<p>Already covered when CEL dump was checked. Not required to be checked again by the SPACON. On-Call SOE to check on the next working day.</p>
Failed TC reports H_ODxxxx_128	
Failed TCs H_ODxxxx_TCF	
OOLs H_ODxxxx_OOL	<p>Not required to be checked by the SPACON. On-Call SOE to check on the next working day.</p>
GYRxSTR Cross Checks H_ODxxxx_GSC	<p>Not required to be checked by the SPACON. ACMS SOE to check on the next working day.</p>

## Incomplete TM and Consolidation Problems

Guideline:

- FD expects complete VC-2 TM of previous OD (required to generate AHF)
  - SGS expects complete and consolidated VC-2 and VC-3 TM of previous OD
- If anything of these cannot be provided the corresponding parties must be informed

Aborted dump (-> less TM than expected)	<ol style="list-style-type: none"> <li>1) Add to DTCP report email (in case of aborted VC-2 add FD to the distribution list); report time until TM is available and consolidated, e.g. "During today's DTCP-xxxx the VC-3 dump was aborted. The consolidation could only be completed up to time &lt;insert generation time of the last received VC-3 packet&gt;."</li> <li>2) Inform the next SPACON to recover in next DTCP according to PREP/DTCP procedure</li> </ol>
Failed consolidation (-> TM not releasable)	<ol style="list-style-type: none"> <li>1) Add to DTCP report email</li> <li>2) If failed consolidation is older than 2 days (or only on B):             <ol style="list-style-type: none"> <li>a. On-Call SOE to investigate on next working day</li> </ol> </li> <li>3) If failed consolidation on LTA-A lies within the last 2 days:             <ol style="list-style-type: none"> <li>a. On-Call SOE to investigate before next DTCP</li> </ol> </li> </ol>
Lost TM (on all TMTCS), e.g. due to ground station problem (-> Gaps in TM, failed consolidation, TM not releasable)	<ol style="list-style-type: none"> <li>1) Add to DTCP report email (in case of incomplete VC-2 add FD to the distribution list)</li> <li>2) On-Call SOE to contact On-Call FD (only in case of incomplete VC-2)</li> <li>3) On-Call SOE and SOM to decide (case-by-case) to perform a re-dump of the lost TM in the next DTCP</li> </ol>

# Herschel Pass Report Email (Template)

## Header:

---

**TO:** hscops@sciops.esa.int, hifi-operations@sron.nl, pacs\_ops@sciops.esa.int, spire@stfc.ac.uk

**CC:** H\_FCT, HP\_SWS

**Subject:** Herschel DTCP-xxxx Report

## Content:

---

### DTCP Activities

<Put here general information about the pass, e.g.>

- Today's pass was nominal. No problems occurred
- Not enough time to complete the VC-3 dump, therefore it was aborted
- DTCP was cancelled due to ground station problems

### Mission Timeline

<Put here everything related to MTL, the uplink and OBQD mismatches, e.g.>

- MTL (xxxx+1) part A and B were uplinked
- OBQD showed a mismatch, but in an expected location

### R/T OOLs during the DTCP

<Put here issues from R/T OOL Display, e.g.>

- HIFI TM parameter XYZ showed OOL from time to time
- None

### Critical Events

<Put here issues from CEL dump and R/T TM, ignoring SPID 11104109, e.g.>

- None

### Unknown Packets

<Put here issues from TMPH when filtered for POPA printout, and from R/T TM, e.g.>

- None
- A few unknown packets were received. The On-Call SOE was informed and will check tomorrow morning.

### Failed TCs

<Put here issues from CEL dump and R/T TM, e.g. >

- None (only the expected ACMS TCs failed)
- HIFI memory check TC failed at time

### TM Completeness and Consolidation

<Put here infos about dump, from TM transfer and consolidation, e.g.>

- TM dumps and consolidation of OD (xxxx-1) is completed
- Due to the aborted dump, the consolidation could only be completed up to time <insert generation time of the last received VC-3 packet>
- Following windows failed consolidation: ... The On-Call SOE was informed and will check tomorrow morning.

### Other Issues

<Put here everything else of note, e.g.>

- None

# Other useful Stuff you should know

## Permanent Telecon

If required, you can always setup following permanent telecon:

+49 69 21 0869700                      Admin pin      46193960                      Guest pin      49575512

## Informing the next SPACON about expected impact of Special Operations

Expected TM gaps (which will fail consolidation in the next OD); e.g. today's PM reboot will cause tomorrow's consolidation to fail (some SSCs restarted from zero).

- ➔ SOM or SOE in charge to write pre-warning email to HSC, ICCs and SPACONS: SPACON of next DTCP can do final consolidation for these expected TM gaps.

Expected events, OOLs or failed commands

- ➔ SOM or SOE in charge to write pre-warning email to HSC, ICCs and SPACONS: SPACON of next DTCP can ignore these issues.

## Blind Commanding

Blind commanding (= no TM) only in BD and with dynamic PTV disabled. Do the same when TM rate is 500 bps (the TM is so slow that the TM flag toggles between red and green).

## Ground Segment TM Flow

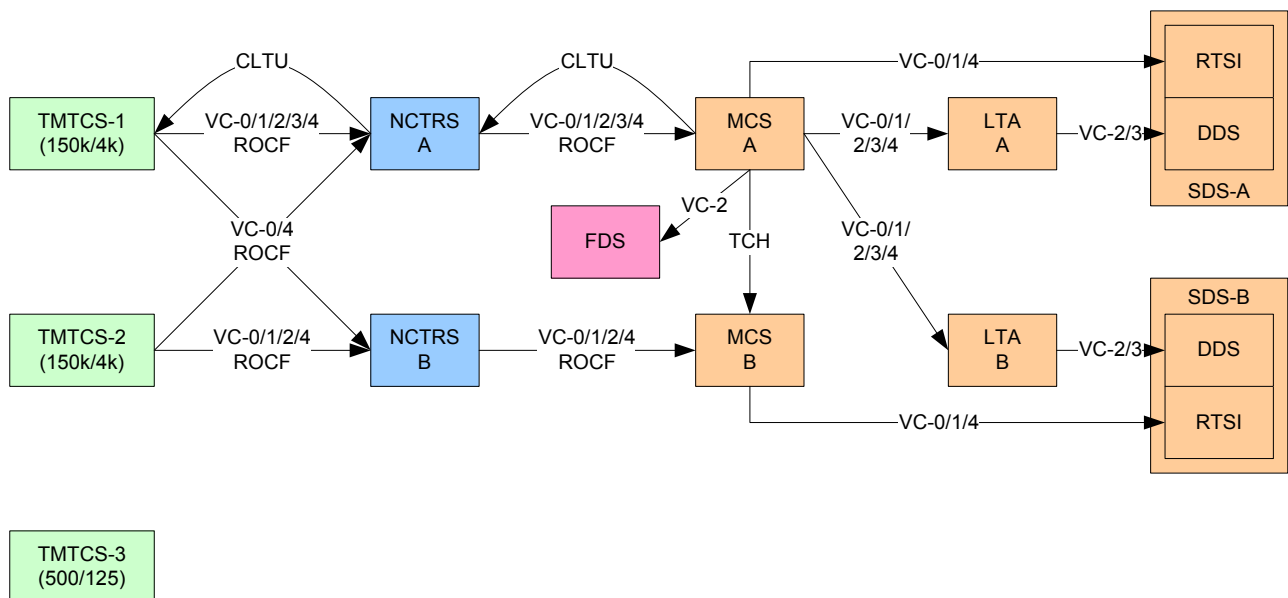

## **MTL Uplink "CRP"**

Following steps must be performed by the SPACON whenever the MTL uplink stopped by unknown reason.

1. Click Stop on ASTK (preventive action to avoid surprises)
2. Get the AD report value (e.g. from Overview MIMIC), when R/T TM is available. Convert it to hex.
3. Find this (value-1) on the TC History (hex in TCH !): The corresponding TC is the last one confirmed onboard (don't trust any colours)
4. Find this TC on the ASTK (don't trust any colours), get the row number (x)
5. Re-initialize AD mode if necessary
6. Connection Test:
  - A. Remember the last TC on the TCH
  - B. Send a Connection Test from the MSTK in AD mode
  - C. Check TCH: Did only this Connection Test TC appear new as released? Should more TCs appear, they were invisible pending in the Releaser. Restart from step 2 again and repeat the AD counter check (x will change).
7. Continue the MTL uplink with the following row (x+1)

# List of FOP Procedures

## On-Call SOE must be qualified to run following procedures:

- H\_CRP\_HIF\_CALL
  - H\_CRP\_OBS\_LCUD
  - H\_CRP\_OBS\_LCUP
  - H\_FCP\_HIF\_2Dxx
- H\_CRP\_SPI\_DUMP
- H\_FCP\_AOC\_5007
- H\_CRP\_AOC\_4S01
  - H\_FCP\_AOC\_8ON1
- H\_CRP\_SYS\_NOTC
- H\_CRP\_SYS\_NOTM
  - H\_FCP\_DHS\_3007
  - H\_CRP\_TTC\_ENCR
  - H\_CRP\_TTC\_FDIR
  - H\_CRP\_TTC\_T201
  - H\_CRP\_TTC\_TU01
  - H\_FCP\_TTC\_QCHK
  - H\_FCP\_TTC\_TU01
- H\_CRP\_SYS\_BLIND
- H\_CRP\_SYS\_ANOM
  - H\_CRP\_SYS\_CHECK
    - H\_CRP\_AOC\_2BRT
    - H\_FCP\_AOC\_3011
    - H\_FCP\_DHS\_1030
    - H\_FCP\_DHS\_3012
    - H\_FCP\_DHS\_3014
    - H\_FCP\_DHS\_3015
    - H\_FCP\_DHS\_3021
  - H\_CRP\_SYS\_TMTC
    - H\_FCP\_DHS\_1003
    - H\_FCP\_DHS\_1009
    - H\_FCP\_DHS\_3040
    - H\_CRP\_DHS\_HKCY
    - H\_FCP\_TTC\_R2BR
    - H\_FCP\_TTC\_RUBR
    - H\_FCP\_TTC\_TUCM
    - H\_CRP\_TTC\_TUL2
    - H\_FCP\_TTC\_TUMR
    - H\_FCP\_TTC\_TURM

## SPACON must be qualified to run following procedures:

- C\_GSP\_SYS\_PREP
- H\_GSP\_SYS\_DTCP
- C\_GSP\_SYS\_POPA
- H\_CRP\_SYS\_NOTM (first part)
- H\_CRP\_SYS\_NOTC
- H\_CRP\_HIF\_SPCN