

Load SPU software (Redundant)
File: H_FCP_PAC_RLSM.xls
Author: R. Biggins



Procedure Summary

Objectives

The objective of this procedure is to load a new version of the nominal SPU software

- Switch to PACS bus profile
- Enable RT interrogations for PACS RTA
- Switch ON and boot redundant DPU
- Enable SDB FDIR for PACS RTA
- Switch on and connect SPU
- Execute SPU red and blue memory checks
- Load new SPU OBSW using procedure H_FCP_OBS_4210
- Copy HLSW (red and blue) from EEPROM to RAM
- Check and verify SPU RAM contents
- Disable RT interrogations for PACS RTA
- Switch off SPU
- Switch off redundant DPU

Based on procedures:

Pacs_Switch_On_DPU_SPULLSW_Redundant_30_07_2007
Pacs_Spu_MemCheck_All_13_8_05_10_2007
PACS_Switch_Off_Redundant_28_07_2007

Summary of Constraints

PACS has been switched off for at least 4 minutes.

This procedure is valid to load the SPU OBSW version 13.96

Spacecraft Configuration

Start of Procedure

- PACS is OFF
- All PACS units powered off
 - UIU table shows PACS units OFF

End of Procedure

- PACS is OFF
- All PACS units powered off
 - UIU table shows PACS units OFF

Reference File(s)

Input Command Sequences

Output Command Sequences

HFPRLSM

Referenced Displays

ANDs	GRDs	SLDs
ZAZ9A999		
ZAZ9B999		

Configuration Control Information

Load SPU software (Redundant)
 File: H_FCP_PAC_RLSM.xls
 Author: R. Biggins



DATE	FOP ISSUE	VERSION	MODIFICATION DESCRIPTION	AUTHOR	SPR REF
20/09/07		1	Created	R. Biggins	
22/11/07		1.01	Validation : Time tags added to SVM commands	R. Biggins	
04/12/07		2	TC and TM updated for SPU UM v3.2.2, software version 13.8	R. Biggins	
21/01/08		3	Update due to initial testing against the simulator: - TCs updated due to new DB - Execution times removed - Editorial updates	R. Biggins	
03/03/08		4	Update due to testing against MOC Simulator and comments by S. Pezzuto: - Telecommand flags updated - Telemetry check added to step 6.2 - Editorial updates	R. Biggins	
05/03/08		4.01	Validation : Update due to comments by S. Pezzuto: - Telemetry values in step 6.3 updated	R. Biggins	
27/05/08	1	5	Updates due to SVT-1 testing: - TC to start RT interrogations updated (step 4.3) - TC to enable FDIR moved from step 12.5 to step 4.5 - TC to disable RT interrogations moved to before LCL switch off - TC to disable SDB FDIR (step 12.2) removed - SPU memory checks (EEPROM) removed (duplicated with OBSM procedure) - SPU memory check checksum values (RAM) moved to attachment - Expected LCL currents updated - Comments added/updated - Flags updated - AND updated for all TM parameters	R. Biggins	
23/10/08	2	6	Updates due to new procedures from industry - Step 4.2 and 4.3 combined - TC DC005161 database definition updated	R. Biggins	
23/03/09	2.2	7	Final updates before flight - Summary updated - TC flags updated - Memory checks updated to reflect current software versions	R. Biggins	
17/04/09	2.3	7.01	Validation : Editorial updates due to comments from project/industry	R. Biggins	

Load SPU software (Redundant)
File: H_FCP_PAC_RLSM.xls
Author: R. Biggins



Procedure Flowchart Overview

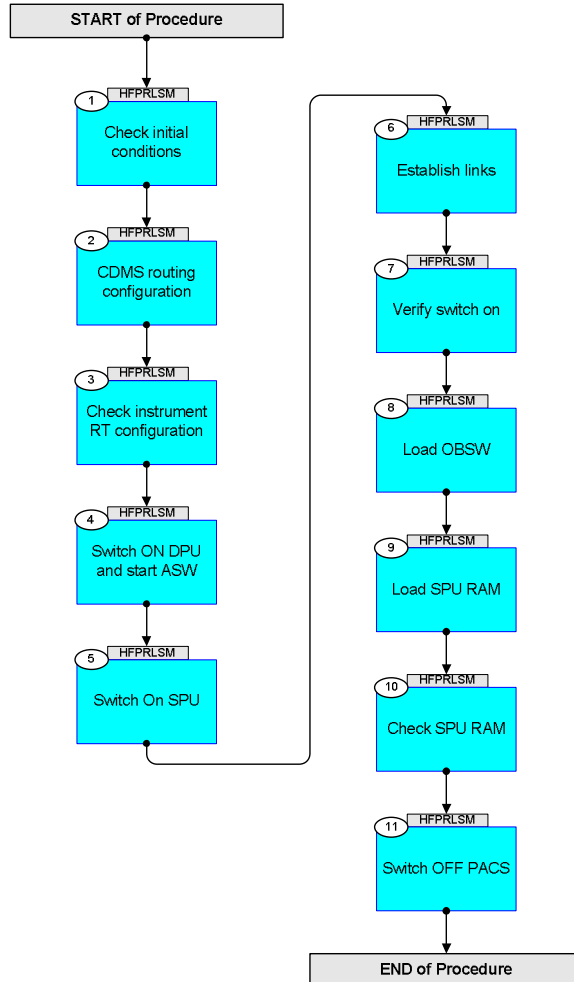

Load SPU software (Redundant)
 File: H_FCP_PAC_RLSM.xls
 Author: R. Biggins



Step No.	Time	Activity/Remarks	TC/TLM	Display/ Branch
Beginning of Procedure				
TC Seq. Name : HFPRLSM (Load SPU s/w (Red))				
TimeTag Type: N Sub Schedule ID: <input type="checkbox"/>				
1		Check initial conditions		Next Step: 2
		Verify: PACS has been switched off for at least 4 minutes		
1.1		PACS input		<input type="checkbox"/>
		Verify that the correct information has been supplied by the ICC: Software Image for SPU OBSW (verify with OBSM engineer)		
		Verify that the PACS ICC has indicated whether the DPU is to be booted from the primary or secondary partition (step 4.6) DPU_PRTN = 1 or 2		
1.2		Spacecraft mode		<input type="checkbox"/>
		Verify Telemetry CurrentMode DEL34170 = Nominal		AND=ZAZ9A999
		Verify Telemetry ACC_A_MODE AEE8G050 = Nominal		AND=ZAZ9A999
1.3		Bus status		<input type="checkbox"/>
		Verify Bus configuration		
		Verify: Active 1553 bus Active_Bus_A_B DEFJ1160 = BUS_A		AND=ZAZ9A999
		Verify: 1553 bus FDIR status SDB_FDIR DEFJ4160 = ENABLED		AND=ZAZ9A999
		Verify: SDB handling status BSW_SDB_ENAB DEF60160 = ENABLED		AND=ZAZ9A999
		Verify bus health status		

Load SPU software (Redundant)
 File: H_FCP_PAC_RLSM.xls
 Author: R. Biggins



Step No.	Time	Activity/Remarks	TC/TLM	Display/ Branch
		Verify: Bus (side A) health status BusA_HealthySts DEFJ2160	= Healthy	AND=ZAZ9A999
		Verify: Bus (side B) health status BusB_HealthySts DEFJ3160	= Healthy	AND=ZAZ9A999
1.4		<i>Redundant instrument LCLs</i>		☐
		Verify: DPU LCL status PacsD_R_L42_S WM42B565	= OFF	AND=ZAZ9A999
		Verify: SPU LCL status PacsS_R_L36_S WM62A565	= OFF	AND=ZAZ9A999
		Verify: BOLC LCL status PacsB_R_L28_1S WM32D565	= OFF	AND=ZAZ9A999
		Verify: Dec/Mec2 LCL status PacsMec2_L69_1S WM62E565	= OFF	AND=ZAZ9A999
1.5		<i>Nominal instrument LCLs</i>		☐
		Verify: DPU LCL status PacsD_N_L41_S WM72B565	= OFF	AND=ZAZ9A999
		Verify: SPU LCL status PacsS_N_L35_S WM52A565	= OFF	AND=ZAZ9A999
		Verify: BOLC LCL status PacsB_N_L27_1S WM82D565	= OFF	AND=ZAZ9A999
		Verify: Dec/Mec1 LCL status PacsMec1_L65_1S WM52E565	= OFF	AND=ZAZ9A999
2		<i>CDMS routing configuration</i>		Next Step: 3
	ET=+ UT=+00.00.00	Execute Telecommand RepDownlinkTMStorage TC Control Flags : Subsch. ID : 10 Det. descr. : Report Telemetry Packets Down-linking/ Storage Status GBM IL DSE --Y -- ---	DC141160	
		It should be verified that telemetry packets for ALL PACS APIDs should be transmitted to ground (Transmit_Flag = ENABLED) EXCEPT for TM(21,x) which should be stored in the SSMM (Storage_Flag = ENABLED, Transmit_Flag = DISABLED). This should be verified on the VPD		

Load SPU software (Redundant)
 File: H_FCP_PAC_RLSM.xls
 Author: R. Biggins



Step No.	Time	Activity/Remarks	TC/TLM	Display/ Branch
		Verify Packet Reception Telemetry Packets DownLinking-Storage Status Report Packet Details: APID: 16 Type: 14 Subtype: 7 PI1: PI2:	(14,7)-1400	
3		Check instrument RT configuration		Next Step: 4
3.1		Remote Terminal configuration		<input type="checkbox"/>
		Verify Telemetry PACS_VitalNonV DED5G161	= NonVital	AND=ZAZ9A999
		Verify Telemetry PACS_TmRetry DED5Z161	= ON	AND=ZAZ9A999
3.2		Remote Terminal Status		<input type="checkbox"/>
		Redundant units		
		Verify Telemetry PACSB_OnOff DED31161	= OFF	AND=ZAZ9A999
		Verify Telemetry PACSB_DeadAliv DED32161	= Alive	AND=ZAZ9A999
		Verify Telemetry PACSB_WellsiTC DED33161	= Well	AND=ZAZ9A999
		Verify Telemetry PACSB_WellsiTM DED34161	= Well	AND=ZAZ9A999
		Verify Telemetry PACSB_ValidInv DED35161	= Invalid	AND=ZAZ9A999
		Nominal units		
		Verify Telemetry PACSA_OnOff DED2G161	= OFF	AND=ZAZ9A999
		Verify Telemetry PACSA_DeadAliv DED2H161	= Alive	AND=ZAZ9A999
		Verify Telemetry PACSA_WellsiTC DED2Z161	= Well	AND=ZAZ9A999
		Verify Telemetry PACSA_WellsiTM DED2J161	= Well	AND=ZAZ9A999
		Verify Telemetry PACSA_ValidInv DED2K161	= Invalid	AND=ZAZ9A999

Load SPU software (Redundant)
 File: H_FCP_PAC_RLSM.xls
 Author: R. Biggins



Step No.	Time	Activity/Remarks	TC/TLM	Display/ Branch
4		Switch ON DPU and start ASW		Next Step: 5
4.1		Set Bus Profile		<input type="checkbox"/>
	ET=+ UT=+00.00.00	Execute Telecommand SelectActiveSCBP Command Parameter(s) : SCBP DH049160 TC Control Flags : GBM IL DSE --Y -- --- Subsch. ID : 10 Det. descr. : Select Active SCBP from SCBP Table	DC819160 SCBP_04	
		Verify: Bus profile BSW_SDB_ActProf DEF5F160	= 4 <dec>	AND=ZAZ9A999
4.2		Disable SDB FDIR and enable RT interrogations		<input type="checkbox"/>
		NOTE: The following TC acts in the following order: - disables the SDB FDIR for the whole spacecraft - updates the RTA status		
	ET=+ UT=+00.00.00	Execute Telecommand ConfigureSDBFDIR Command Parameter(s) : RTA DH011161 PACS A M0 DH030161 Update status M1 DH031161 Ignore Flag M2 DH032161 Ignore Flag M3 DH033161 Ignore Flag M4 DH034161 Update status M5 DH035161 Ignore Flag M6 DH036161 Update status M7 DH037161 Ignore Flag F0 DH018161 ON F1 DH019161 Alive F2 DH020161 Well TC F3 DH021161 Well TM F4 DH022161 Valid F5 DH023161 Non-vital F6 DH024161 NOMINAL F7 DH025161 ON M12 DH051161 Ignore Flag M_C DH043161 Ignore CNT M8 DH038161 Ignore Flag M9 DH039161 Ignore Flag M10 DH040161 Ignore Flag M11 DH041161 Update status F12 DH050161 ENABLED CNT DH042161 LoopCnt1 F8 DH026161 Bus A	DC005161	

Load SPU software (Redundant)
 File: H_FCP_PAC_RLSM.xls
 Author: R. Biggins



Step No.	Time	Activity/Remarks	TC/TLM	Display/ Branch
		F9 DH027161 F10 DH028161 F11 DH029161 TC Control Flags : Subsch. ID : 10 Det. descr. : Configure SDB FDIR GBM IL DSE --Y -- ---	Healthy Healthy DISABLED	
		Wait up to 1 minute for the generation of the D_Hk_P64 packet from the CDMU (APID = 18)		
		Verify: 1553 bus FDIR status SDB_FDIR DEFJ4160	= DISABLED	AND=ZAZ9A999
		Verify Telemetry PACS_NomRed DED5H161	= REDUNDANT	AND=ZAZ9A999
		Verify Telemetry PACSB_OnOff DED31161	= ON	AND=ZAZ9A999
		Verify Telemetry PACSB_ValidInv DED35161	= Valid	AND=ZAZ9A999
4.3		Switch ON DPU LCL		<input type="checkbox"/>
		Switching ON the DPU LCL will initialise BSW. This will initially execute memory checks (failures will generate TM(5,4) packets) and then generate TM(5,1) [EVENT_REPORT_3_32776] packets every 10 seconds.		
	ET=+ UT=+00.00.00	Execute Telecommand SwOn_PacsD_R_L42 TC Control Flags : Subsch. ID : 10 Det. descr. : PCDU: TC(8,4,112,5) PACS DPU Red - switch LCL_42 on GBM IL DSE --Y -- ---	DC42D170	
		Verify: DPU LCL status PacsD_R_L42_S WM42B565	= ON	AND=ZAZ9A999
		Verify: DPU LCL current (+/- 0.1A) PacsD_R_L42_I WM407565	= 0.49 A	AND=ZAZ9A999
4.4		DPU Force Boot		<input type="checkbox"/>
		Sending the FORCE_BOOT TC will generate a TM(5,1) [EVENT_REPORT_3_33041] packet from the BSW.		

Load SPU software (Redundant)
 File: H_FCP_PAC_RLSM.xls
 Author: R. Biggins



Step No.	Time	Activity/Remarks	TC/TLM	Display/ Branch
	ET=+ UT=+00.00.15	DPU_LLSW_FORCE_BOOT DPU_LLSW_FORCE_BOOT Command Parameter(s) : DPU_STRUCTURE_ID PP002380 DPU_PARTITION PP267380 Subsch. ID : 90 Det. descr. : FORCE THE BOOT OF THE DPU LLSW FROM EEPROM	PC032380 1 <dec> (Def) DPU_PRTN	
		Verify: The following TM(3,25) packets should be generated: PACS_essential_HK (APID 1153) PACS_NO_PRIME_HK (APID 1155)		
4.5		Re-enable SDB FDIR		<input type="checkbox"/>
	ET=+ UT=+00.00.00	Execute Telecommand ConfigureSDBFDIR Command Parameter(s) : RTA DH011161 PACS B M0 DH030161 Ignore Flag M1 DH031161 Ignore Flag M2 DH032161 Ignore Flag M3 DH033161 Ignore Flag M4 DH034161 Ignore Flag M5 DH035161 Ignore Flag M6 DH036161 Ignore Flag M7 DH037161 Ignore Flag F0 DH018161 OFF F1 DH019161 Alive F2 DH020161 Well TC F3 DH021161 Well TM F4 DH022161 Invalid F5 DH023161 Non-vital F6 DH024161 NOMINAL F7 DH025161 ON M12 DH051161 Ignore Flag M_C DH043161 Ignore CNT M8 DH038161 Ignore Flag M9 DH039161 Ignore Flag M10 DH040161 Ignore Flag M11 DH041161 Update status F12 DH050161 ENABLED CNT DH042161 LoopCnt1 F8 DH026161 Bus A F9 DH027161 Healthy F10 DH028161 Unhealthy F11 DH029161 ENABLED TC Control Flags : GBM IL DSE --Y -- --- Subsch. ID : 10 Det. descr. : Configure SDB FDIR	DC005161	

Load SPU software (Redundant)
 File: H_FCP_PAC_RLSM.xls
 Author: R. Biggins



Step No.	Time	Activity/Remarks	TC/TLM	Display/ Branch
		Wait up to 1 minute for the generation of the D_Hk_P64 packet from the CDMU (APID = 18)		
		Verify: 1553 bus FDIR status SDB_FDIR DEFJ4160	= ENABLED	AND=ZAZ9B999
5		Switch On SPU		Next Step: 6
	ET=+ UT=+00.00.00	Execute Telecommand SwOn_PacsS_R_L36 TC Control Flags : GBM IL DSE --Y -- -- Subsch. ID : 10 Det. descr. : PCDU: TC(8,4,112,5) PACS SPU Red - switch LCL_36 on	DC36D170	
		Verify: SPU LCL status PacsS_R_L36_S WM62A565	= ON	AND=ZAZ9A999
		Verify: SPU LCL current (+/- 0.1A) PacsS_R_L36_I WM606565	= 0.4 A	AND=ZAZ9A999
6		Establish links		Next Step: 7
6.1		DPU reset of 1355		<input type="checkbox"/>
	ET=+ UT=+00.00.28	DPU_RESET_1355 DPU_RESET_1355 Subsch. ID : 90 Det. descr. : DPU RESET THE 1355 CHIP	PC025380	
6.2		DPU - SPU links		<input type="checkbox"/>
		WARNING: the following TCs must be sent with the exact time delay as defined		
		Sending this TC will generate the following TM(5,1) packets: EVENT_REPORT_5_28 - Unexp 1355 ACK EVENT_REPORT_0_14 - SPUS DEAD		

Load SPU software (Redundant)
 File: H_FCP_PAC_RLSM.xls
 Author: R. Biggins



Step No.	Time	Activity/Remarks	TC/TLM	Display/ Branch
	ET=+ UT=+00.00.10	Initialise DPU - blue SPU links <p style="text-align: right;">DPU_START_OBCP</p> Command Parameter(s) : PROCEDURE_ID PP012380 NUMBER_OF_TIMES PP010380 PAR_ID PP011380 PAR_VALUE PP017380 PAR_ID PP011380 PAR_VALUE PP017380 TC Control Flags : <p style="text-align: right;">GBM IL DSE --Y -- ---</p> Subsch. ID : 90 Det. descr. : START AN OBCP WITH THE COMMANDED PARAMETERS	PC012380 START_1355_LINK 2 <dec> (Def) 1 <dec> 1 <dec> 2 <dec> 1 <dec>	
		Sending this TC will generate the following TM(5,1) packets: EVENT_REPORT_5_28 - Unexp 1355 ACK EVENT_REPORT_0_10 - SPUL DEAD		
	ET=+ UT=+00.00.04	Initialise DPU - red SPU links <p style="text-align: right;">DPU_START_OBCP</p> Command Parameter(s) : PROCEDURE_ID PP012380 NUMBER_OF_TIMES PP010380 PAR_ID PP011380 PAR_VALUE PP017380 PAR_ID PP011380 PAR_VALUE PP017380 Subsch. ID : 90 Det. descr. : START AN OBCP WITH THE COMMANDED PARAMETERS	PC012380 START_1355_LINK 2 <dec> (Def) 1 <dec> 2 <dec> 2 <dec> 1 <dec>	
		Verify Telemetry <p style="text-align: right;">DP_SPS_LINK PM020380</p>	= ON	AND=ZAZ9A999
		Verify Telemetry <p style="text-align: right;">DP_SPL_LINK PM021380</p>	= ON	AND=ZAZ9A999
6.3		SPU Memory self test: dump blue		□

Load SPU software (Redundant)
 File: H_FCP_PAC_RLSM.xls
 Author: R. Biggins



Step No.	Time	Activity/Remarks	TC/TLM	Display/ Branch
	ET=+ UT=+00.00.04	DPU_MEMORY_DUMP DPU_MEMORY_DUMP Command Parameter(s) : DPU_MEMORY_BLOCK_ID PP009380 DPU_MEMORY_ADDR PP003380 DPU_DATA_LENGTH PP008380 TC Control Flags : GBM IL DSE --Y -- --- Subsch. ID : 90 Det. descr. : DUMP OF A DPU MEMORY AREA	PC028380 5100 <hex> 0 <hex> 17 <dec>	
		Verify: The following TM(6,6) packet should be produced: PACS_MEMORY_DUMP (APID 1153)		
		For PACS SPU OBSW v13.96: 0x 0000 0001 0x 0007 FFFF 0x 0000 6823 0x 0000 6823 Although the rest of the dump should be 0x0000 0000, it is not unexpected if it is not. This should be analysed by PACS offline		
6.4		SPU Memory self test: dump red		<input type="checkbox"/>
	ET=+ UT=+00.00.01	DPU_MEMORY_DUMP DPU_MEMORY_DUMP Command Parameter(s) : DPU_MEMORY_BLOCK_ID PP009380 DPU_MEMORY_ADDR PP003380 DPU_DATA_LENGTH PP008380 TC Control Flags : GBM IL DSE --Y -- --- Subsch. ID : 90 Det. descr. : DUMP OF A DPU MEMORY AREA	PC028380 7100 <hex> 0 <hex> 17 <dec>	
		Verify: The following TM(6,6) packet should be produced: PACS_MEMORY_DUMP (APID 1153)		

Load SPU software (Redundant)
 File: H_FCP_PAC_RLSM.xls
 Author: R. Biggins



Step No.	Time	Activity/Remarks	TC/TLM	Display/ Branch
		For PACS SPU OBSW v13.96: 0x 0000 0001 0x 0007 FFFF 0x 0000 6823 0x 0000 6823 Although the rest of the dump should be 0x0000 0000, it is not unexpected if it is not. This should be analysed by PACS offline		
7		Verify switch on		Next Step: 8
		Verify Telemetry DP_SPUS_HK PM026380 = NO NEW HK		AND=ZAZ9A999
		Verify Telemetry DP_SPUL_HK PM027380 = NO NEW HK		AND=ZAZ9A999
8		Load OBSW		Next Step: 9
		OBSM engineer to run the procedure H_FCP_OBS_4210 to generate the saved stack files for upload.		
		The OBSM procedure will generate a saved stack file and uplink the load commands to PACS. It will also verify that the load is successful by checksum verification of the on-board image.		
		WARNING: The relevant authority (TBD) should be informed that the SPU EEPROM is being written to in order to monitor the total number of write cycles as the EEPROM has only a limited number of cycles.		
9		Load SPU RAM		Next Step: 10
9.1		Load SPU Red HLSW from EEPROM to RAM		<input type="checkbox"/>
	ET=+ UT=+00.00.01	SPUL_LLSW_LOAD_EEPROM Command Parameter(s) : SPUL_EEPROM_MEMORY_ID PP040390 SPUL_EEPROM_START_ADDR PP042390 SPUL_RAM_MEMORY_ID PP041390 SPUL_RAM_START_ADDR PP043390 SPUL_DATA_LENGTH_HLSW PP038390 TC Control Flags : GBM IL DSE --Y -- -- Subsch. ID : 90 Det. descr. : LOAD SPU HLSW FROM EEPROM FOR RED SPU	PC070390 3 <hex> 100 <hex> 1 <hex> 100 <hex> 1E0 <hex>	

Load SPU software (Redundant)
 File: H_FCP_PAC_RLSM.xls
 Author: R. Biggins



Step No.	Time	Activity/Remarks	TC/TLM	Display/ Branch
	ET=+ UT=+00.00.02	SPUL_LLSW_LOAD_EEPROM SPUL_LLSW_LOAD_EEPROM Command Parameter(s) : SPUL_EEPROM_MEMORY_ID PP040390 SPUL_EEPROM_START_ADDR PP042390 SPUL_RAM_MEMORY_ID PP041390 SPUL_RAM_START_ADDR PP043390 SPUL_DATA_LENGTH_HLSW PP038390 Subsch. ID : 90 Det. descr. : LOAD SPU HLSW FROM EEPROM FOR RED SPU	PC070390 3 <hex> 300 <hex> 1 <hex> 300 <hex> 700 <hex>	
	ET=+ UT=+00.00.02	SPUL_LLSW_LOAD_EEPROM SPUL_LLSW_LOAD_EEPROM Command Parameter(s) : SPUL_EEPROM_MEMORY_ID PP040390 SPUL_EEPROM_START_ADDR PP042390 SPUL_RAM_MEMORY_ID PP041390 SPUL_RAM_START_ADDR PP043390 SPUL_DATA_LENGTH_HLSW PP038390 Subsch. ID : 90 Det. descr. : LOAD SPU HLSW FROM EEPROM FOR RED SPU	PC070390 3 <hex> a00 <hex> 1 <hex> a00 <hex> a600 <hex>	
9.2		Load SPU Blue HLSW from EEPROM to RAM		□
	ET=+ UT=+00.00.02	SPUS_LLSW_LOAD_EEPROM SPUS_LLSW_LOAD_EEPROM Command Parameter(s) : SPUS_EEPROM_MEMORY_ID PP058400 SPUS_EEPROM_START_ADDR PP060400 SPUS_RAM_MEMORY_ID PP059400 SPUS_RAM_START_ADDR PP061400 SPUS_DATA_LENGTH_HLSW PP056400 Subsch. ID : 90 Det. descr. : LOAD SPU HLSW FROM EEPROM FOR BLUE SPU	PC069400 3 <hex> 100 <hex> 1 <hex> 100 <hex> 1e0 <hex>	
	ET=+ UT=+00.00.02	SPUS_LLSW_LOAD_EEPROM SPUS_LLSW_LOAD_EEPROM Command Parameter(s) : SPUS_EEPROM_MEMORY_ID PP058400 SPUS_EEPROM_START_ADDR PP060400 SPUS_RAM_MEMORY_ID PP059400 SPUS_RAM_START_ADDR PP061400 SPUS_DATA_LENGTH_HLSW PP056400 Subsch. ID : 90 Det. descr. : LOAD SPU HLSW FROM EEPROM FOR BLUE SPU	PC069400 3 <hex> 300 <hex> 1 <hex> 300 <hex> 700 <hex>	

Load SPU software (Redundant)
 File: H_FCP_PAC_RLSM.xls
 Author: R. Biggins



Step No.	Time	Activity/Remarks	TC/TLM	Display/ Branch
	ET=+ UT=+00.00.02	SPUS_LLSW_LOAD_EEPROM SPUS_LLSW_LOAD_EEPROM Command Parameter(s) : SPUS_EEPROM_MEMORY_ID PP058400 SPUS_EEPROM_START_ADDR PP060400 SPUS_RAM_MEMORY_ID PP059400 SPUS_RAM_START_ADDR PP061400 SPUS_DATA_LENGTH_HLSW PP056400 Subsch. ID : 90 Det. descr. : LOAD SPU HLSW FROM EEPROM FOR BLUE SPU	PC069400 3 <hex> a00 <hex> 1 <hex> a00 <hex> a600 <hex>	
10		Check SPU RAM		Next Step: 11
10.1		Check table segments in SPU RAM		<input type="checkbox"/>
		The following checks will verify the contents of the SPU Program Memory (RAM)		
		For PACS SPU OBSW v13.96: CHECKSUM1 = FEB0 CHECKSUM2 = DDCD		
	ET=+ UT=+00.00.00	DPU_MEMORY_CHECK_RAW DPU_MEMORY_CHECK Command Parameter(s) : DPU_MEMORY_BLOCK_ID PP009380 DPU_MEMORY_ADDR PP003380 DPU_DATA_LENGTH PP008380 TC Control Flags : GBM IL DSE --Y -- --- Subsch. ID : 90 Det. descr. : REQUEST FOR A CHECKSUM OF A SPECIFIED MEMORY AREA	PC029380 8100 <hex> 100 <hex> 100 <hex>	
		Verify: SPU memory checksum CHECKSUM PM132380	CHECKSUM1	AND=ZAZ9A999
	ET=+ UT=+00.00.01	Check init table segment DPU_MEMORY_CHECK Command Parameter(s) : DPU_MEMORY_BLOCK_ID PP009380 DPU_MEMORY_ADDR PP003380 DPU_DATA_LENGTH PP008380 TC Control Flags : GBM IL DSE --Y -- --- Subsch. ID : 90 Det. descr. : REQUEST FOR A CHECKSUM OF A SPECIFIED MEMORY AREA	PC029380 8100 <hex> 300 <hex> 21E <hex>	

Load SPU software (Redundant)
 File: H_FCP_PAC_RLSM.xls
 Author: R. Biggins



Step No.	Time	Activity/Remarks	TC/TLM	Display/ Branch
		Verify: SPU memory checksum CHECKSUM PM132380	CHECKSUM2	AND=ZAZ9A999
10.2		Check program code segment in SPU RAM		<input type="checkbox"/>
		The following checks will verify the contents of the SPU Program Memory (RAM)		
		Uplink the memory check commands one by one and verify the received checksums (PM132380) against the corresponding expected values in Attachment 1.		
	ET=+ UT=+00.00.01	DPU_MEMORY_CHECK_RAW DPU_MEMORY_CHECK Command Parameter(s) : DPU_MEMORY_BLOCK_ID PP009380 DPU_MEMORY_ADDR PP003380 DPU_DATA_LENGTH PP008380 TC Control Flags : GBM IL DSE --Y -- -- Subsch. ID : 90 Det. descr. : REQUEST FOR A CHECKSUM OF A SPECIFIED MEMORY AREA	PC029380 8100 <hex> A00 <hex> 800 <hex>	
	ET=+ UT=+00.00.01	DPU_MEMORY_CHECK_RAW DPU_MEMORY_CHECK Command Parameter(s) : DPU_MEMORY_BLOCK_ID PP009380 DPU_MEMORY_ADDR PP003380 DPU_DATA_LENGTH PP008380 TC Control Flags : GBM IL DSE --Y -- -- Subsch. ID : 90 Det. descr. : REQUEST FOR A CHECKSUM OF A SPECIFIED MEMORY AREA	PC029380 8100 <hex> 1200 <hex> 800 <hex>	
	ET=+ UT=+00.00.01	DPU_MEMORY_CHECK_RAW DPU_MEMORY_CHECK Command Parameter(s) : DPU_MEMORY_BLOCK_ID PP009380 DPU_MEMORY_ADDR PP003380 DPU_DATA_LENGTH PP008380 TC Control Flags : GBM IL DSE --Y -- -- Subsch. ID : 90 Det. descr. : REQUEST FOR A CHECKSUM OF A SPECIFIED MEMORY AREA	PC029380 8100 <hex> 1A00 <hex> 800 <hex>	

Load SPU software (Redundant)
 File: H_FCP_PAC_RLSM.xls
 Author: R. Biggins



Step No.	Time	Activity/Remarks	TC/TLM	Display/ Branch
	ET=+ UT=+00.00.01	DPU_MEMORY_CHECK_RAW DPU_MEMORY_CHECK Command Parameter(s) : DPU_MEMORY_BLOCK_ID PP009380 DPU_MEMORY_ADDR PP003380 DPU_DATA_LENGTH PP008380 TC Control Flags : GBM IL DSE --Y -- --- Subsch. ID : 90 Det. descr. : REQUEST FOR A CHECKSUM OF A SPECIFIED MEMORY AREA	PC029380 8100 <hex> 2200 <hex> 800 <hex>	
	ET=+ UT=+00.00.01	DPU_MEMORY_CHECK_RAW DPU_MEMORY_CHECK Command Parameter(s) : DPU_MEMORY_BLOCK_ID PP009380 DPU_MEMORY_ADDR PP003380 DPU_DATA_LENGTH PP008380 TC Control Flags : GBM IL DSE --Y -- --- Subsch. ID : 90 Det. descr. : REQUEST FOR A CHECKSUM OF A SPECIFIED MEMORY AREA	PC029380 8100 <hex> 2A00 <hex> 800 <hex>	
	ET=+ UT=+00.00.01	DPU_MEMORY_CHECK_RAW DPU_MEMORY_CHECK Command Parameter(s) : DPU_MEMORY_BLOCK_ID PP009380 DPU_MEMORY_ADDR PP003380 DPU_DATA_LENGTH PP008380 TC Control Flags : GBM IL DSE --Y -- --- Subsch. ID : 90 Det. descr. : REQUEST FOR A CHECKSUM OF A SPECIFIED MEMORY AREA	PC029380 8100 <hex> 3200 <hex> 800 <hex>	
	ET=+ UT=+00.00.01	DPU_MEMORY_CHECK_RAW DPU_MEMORY_CHECK Command Parameter(s) : DPU_MEMORY_BLOCK_ID PP009380 DPU_MEMORY_ADDR PP003380 DPU_DATA_LENGTH PP008380 TC Control Flags : GBM IL DSE --Y -- --- Subsch. ID : 90 Det. descr. : REQUEST FOR A CHECKSUM OF A SPECIFIED MEMORY AREA	PC029380 8100 <hex> 3A00 <hex> 800 <hex>	

Load SPU software (Redundant)
 File: H_FCP_PAC_RLSM.xls
 Author: R. Biggins



Step No.	Time	Activity/Remarks	TC/TLM	Display/ Branch
	ET=+ UT=+00.00.01	DPU_MEMORY_CHECK_RAW DPU_MEMORY_CHECK Command Parameter(s) : DPU_MEMORY_BLOCK_ID PP009380 DPU_MEMORY_ADDR PP003380 DPU_DATA_LENGTH PP008380 TC Control Flags : GBM IL DSE --Y -- --- Subsch. ID : 90 Det. descr. : REQUEST FOR A CHECKSUM OF A SPECIFIED MEMORY AREA	PC029380 8100 <hex> 4200 <hex> 800 <hex>	
	ET=+ UT=+00.00.01	DPU_MEMORY_CHECK_RAW DPU_MEMORY_CHECK Command Parameter(s) : DPU_MEMORY_BLOCK_ID PP009380 DPU_MEMORY_ADDR PP003380 DPU_DATA_LENGTH PP008380 TC Control Flags : GBM IL DSE --Y -- --- Subsch. ID : 90 Det. descr. : REQUEST FOR A CHECKSUM OF A SPECIFIED MEMORY AREA	PC029380 8100 <hex> 4A00 <hex> 800 <hex>	
	ET=+ UT=+00.00.01	DPU_MEMORY_CHECK_RAW DPU_MEMORY_CHECK Command Parameter(s) : DPU_MEMORY_BLOCK_ID PP009380 DPU_MEMORY_ADDR PP003380 DPU_DATA_LENGTH PP008380 TC Control Flags : GBM IL DSE --Y -- --- Subsch. ID : 90 Det. descr. : REQUEST FOR A CHECKSUM OF A SPECIFIED MEMORY AREA	PC029380 8100 <hex> 5200 <hex> 800 <hex>	
	ET=+ UT=+00.00.01	DPU_MEMORY_CHECK_RAW DPU_MEMORY_CHECK Command Parameter(s) : DPU_MEMORY_BLOCK_ID PP009380 DPU_MEMORY_ADDR PP003380 DPU_DATA_LENGTH PP008380 TC Control Flags : GBM IL DSE --Y -- --- Subsch. ID : 90 Det. descr. : REQUEST FOR A CHECKSUM OF A SPECIFIED MEMORY AREA	PC029380 8100 <hex> 5A00 <hex> 800 <hex>	

Load SPU software (Redundant)
 File: H_FCP_PAC_RLSM.xls
 Author: R. Biggins



Step No.	Time	Activity/Remarks	TC/TLM	Display/ Branch
	ET=+ UT=+00.00.01	DPU_MEMORY_CHECK_RAW DPU_MEMORY_CHECK Command Parameter(s) : DPU_MEMORY_BLOCK_ID PP009380 DPU_MEMORY_ADDR PP003380 DPU_DATA_LENGTH PP008380 TC Control Flags : GBM IL DSE --Y -- --- Subsch. ID : 90 Det. descr. : REQUEST FOR A CHECKSUM OF A SPECIFIED MEMORY AREA	PC029380 8100 <hex> 6200 <hex> 800 <hex>	
	ET=+ UT=+00.00.01	DPU_MEMORY_CHECK_RAW DPU_MEMORY_CHECK Command Parameter(s) : DPU_MEMORY_BLOCK_ID PP009380 DPU_MEMORY_ADDR PP003380 DPU_DATA_LENGTH PP008380 TC Control Flags : GBM IL DSE --Y -- --- Subsch. ID : 90 Det. descr. : REQUEST FOR A CHECKSUM OF A SPECIFIED MEMORY AREA	PC029380 8100 <hex> 6A00 <hex> 800 <hex>	
	ET=+ UT=+00.00.01	DPU_MEMORY_CHECK_RAW DPU_MEMORY_CHECK Command Parameter(s) : DPU_MEMORY_BLOCK_ID PP009380 DPU_MEMORY_ADDR PP003380 DPU_DATA_LENGTH PP008380 TC Control Flags : GBM IL DSE --Y -- --- Subsch. ID : 90 Det. descr. : REQUEST FOR A CHECKSUM OF A SPECIFIED MEMORY AREA	PC029380 8100 <hex> 7200 <hex> 800 <hex>	
	ET=+ UT=+00.00.01	DPU_MEMORY_CHECK_RAW DPU_MEMORY_CHECK Command Parameter(s) : DPU_MEMORY_BLOCK_ID PP009380 DPU_MEMORY_ADDR PP003380 DPU_DATA_LENGTH PP008380 TC Control Flags : GBM IL DSE --Y -- --- Subsch. ID : 90 Det. descr. : REQUEST FOR A CHECKSUM OF A SPECIFIED MEMORY AREA	PC029380 8100 <hex> 7A00 <hex> 800 <hex>	

Load SPU software (Redundant)
 File: H_FCP_PAC_RLSM.xls
 Author: R. Biggins



Step No.	Time	Activity/Remarks	TC/TLM	Display/ Branch
	ET=+ UT=+00.00.01	DPU_MEMORY_CHECK_RAW DPU_MEMORY_CHECK Command Parameter(s) : DPU_MEMORY_BLOCK_ID PP009380 DPU_MEMORY_ADDR PP003380 DPU_DATA_LENGTH PP008380 TC Control Flags : GBM IL DSE --Y -- --- Subsch. ID : 90 Det. descr. : REQUEST FOR A CHECKSUM OF A SPECIFIED MEMORY AREA	PC029380 8100 <hex> 8200 <hex> 39F <hex>	
11		Switch OFF PACS		Next Step: END
11.1		Go to SAFE MODE		<input type="checkbox"/>
		Sending the following TC will generate a TM(5,1) [EVENT_REPORT_6_3 - NACK] packet.		
	ET=+ UT=+00.00.00	DPU_START_OBCP_RAW DPU_START_OBCP Command Parameter(s) : PROCEDURE_ID PP012380 NUMBER_OF_TIMES PP010380 TC Control Flags : GBM IL DSE --Y -- --- Subsch. ID : 90 Det. descr. : START AN OBCP WITH THE COMMANDED PARAMETERS	PC012380 24 <dec> 0 <dec>	
		Verify Telemetry DP_TM_RATE PM049380	= SAFE	AND=ZAZ9A999
11.2		Stop the instrument RT interrogation		<input type="checkbox"/>
	ET=+ UT=+00.00.00	Execute Telecommand ConfiguresSDBFDIR Command Parameter(s) : RTA DH011161 M0 DH030161 M1 DH031161 M2 DH032161 M3 DH033161 M4 DH034161 M5 DH035161 M6 DH036161 M7 DH037161 F0 DH018161 F1 DH019161	DC005161 PACS B Update status Ignore Flag Ignore Flag Ignore Flag Update status Ignore Flag Ignore Flag Ignore Flag OFF Alive	

Load SPU software (Redundant)
 File: H_FCP_PAC_RLSM.xls
 Author: R. Biggins



Step No.	Time	Activity/Remarks	TC/TLM	Display/ Branch
		F2 DH020161 F3 DH021161 F4 DH022161 F5 DH023161 F6 DH024161 F7 DH025161 M12 DH051161 M_C DH043161 M8 DH038161 M9 DH039161 M10 DH040161 M11 DH041161 F12 DH050161 CNT DH042161 F8 DH026161 F9 DH027161 F10 DH028161 F11 DH029161 TC Control Flags : Subsch. ID : 10 Det. descr. : Configure SDB FDIR GBM IL DSE --Y -- ---	Well TC Well TM Invalid Non-vital NOMINAL OFF Ignore Flag Ignore CNT Ignore Flag Ignore Flag Ignore Flag Ignore Flag Ignore Flag ENABLED LoopCnt1 Bus A Healthy Healthy ENABLED	
		Wait up to 1 minute for the generation of the D_H_Hk_P64 packet from the CDMU (APID = 18)		
		Verify Telemetry PACSB_OnOff DED31161	= OFF	AND=ZAZ9A999
		Verify Telemetry PACSB_ValidInv DED35161	= Invalid	AND=ZAZ9A999
11.3		Switch OFF LCLs		□
	ET=+ UT=+00.00.00	Execute Telecommand SwOff_PacSS_R_L36 TC Control Flags : Subsch. ID : 10 Det. descr. : PCDU: TC(8,4,112,3) PACS SPU Red - switch LCL_36 off	DC36B170	
	ET=+ UT=+00.00.01	Execute Telecommand SwOff_PacsD_R_L42 Subsch. ID : 10 Det. descr. : PCDU: TC(8,4,112,3) PACS DPU Red - switch LCL_42 off	DC42B170	
		Verify Telemetry PacsS_R_L36_S WM62A565	= OFF	AND=ZAZ9A999
		Verify Telemetry PacsD_R_L42_S WM42B565	= OFF	AND=ZAZ9A999

Load SPU software (Redundant)
File: H_FCP_PAC_RLSM.xls
Author: R. Biggins



Step No.	Time	Activity/Remarks	TC/TLM	Display/ Branch
End of Procedure				

ATTACHMENT 1

SPU EEPROM contents

H_FCP_PAC_RLSM

Checksums for step 10.2

Block ID: 8100

SPU OBSW version 13.96

DPU_MEMORY_ADDR	DPU_DATA_LENGTH	Checksum (HEX)
A00	800	F921
1200	800	6B58
1A00	800	19D7
2200	800	A26B
2A00	800	21F8
3200	800	3FF2
3A00	800	4118
4200	800	6FB8
4A00	800	092F
5200	800	5D08
5A00	800	CACF
6200	800	CBFD
6A00	800	FDEE
7200	800	3B4F
7A00	800	EC6B
8200	39F	2AB0

Doc No. : PT-HMOC-OPS-FOP-6001-OPS-OAH
Fop Issue : 3.0
Issue Date: 13/04/10

Load SPU software (Redundant)
File: H_FCP_PAC_RLSM.xls
Author: R. Biggins

Status : Version 7 - Unchanged
Last Checkin: 23/03/09