

HifiManCmdSetIntoDissipative_II - 5a
 File: H_FCP_HIF_2D5A.xls
 Author: R. Biggins



Procedure Summary

Objectives

The objective of this procedure is to set HIFI to dissipative (II) mode in band 5A

Based on procedure:
 HifiManCmdSetIntoDissipative_II (v1)

Summary of Constraints

n/a

Spacecraft Configuration

Start of Procedure

End of Procedure

Reference File(s)

Input Command Sequences

Output Command Sequences
 HFH2D5A

Referenced Displays

ANDs GRDs SLDs
 ZAZ9C999

Configuration Control Information

DATE	FOP ISSUE	VERSION	MODIFICATION DESCRIPTION	AUTHOR	SPR REF
08/04/2010		1	Created	R. Biggins	
08/04/2010		1.01	Validation : Editorial updates	R. Biggins	
09/04/2010	3	2	TC to set dissipative band updated	R. Biggins	
01/07/2010	3.1	2.01	Validation : Editorial: Step 7: TM check for band corrected	R. Biggins	

HifiManCmdSetIntoDissipative_II - 5a
File: H_FCP_HIF_2D5A.xls
Author: R. Biggins



Procedure Flowchart Overview

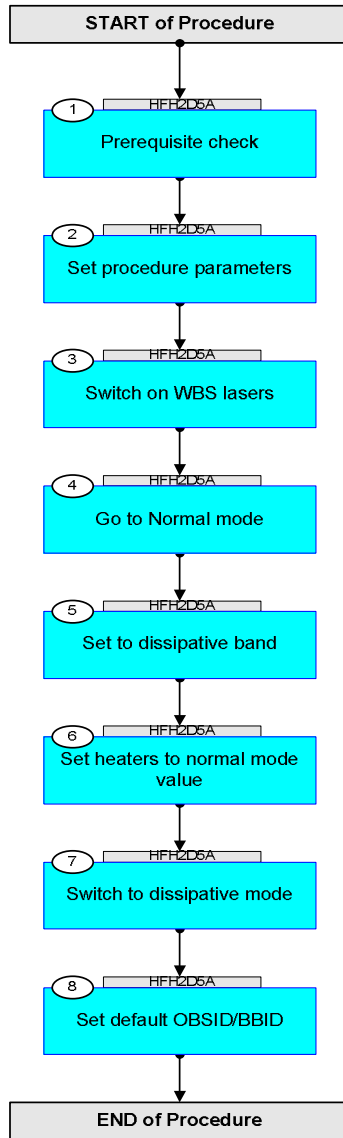

HifiManCmdSetIntoDissipative_II - 5a
 File: H_FCP_HIF_2D5A.xls
 Author: R. Biggins



Step No.	Time	Activity/Remarks	TC/TLM	Display/ Branch
	ET=+ UT=+00.00.00	HIFI_switch_zero_WBS_H HIFI_switch_zero_WBS_H Command Parameter(s) : HIFI_BB_ID HP001197 HW_Zero_S HP162193 TC Control Flags : GBM IL DSE --Y -- --- Subsch. ID : 70 Det. descr. : Send single command to control the WBS-H zero-switch	HC078289 439287809 <dec> ON (Def)	
	ET=+ UT=+00.00.01	HIFI_switch_zero_WBS_V HIFI_switch_zero_WBS_V Command Parameter(s) : HIFI_BB_ID HP001197 HW_Zero_S HP162193 Subsch. ID : 70 Det. descr. : Send single command to control the WBS-V zero-switch	HC079289 439287809 <dec> ON (Def)	
	ET=+ UT=+00.00.01	HIFI_Configure_WBS_H HIFI_Configure_WBS_H Command Parameter(s) : HIFI_BB_ID HP001197 HWH_LASER1_S HP158193 HWH_LASER2_S HP159193 HWH_Heater HP160193 HWH_Latchup_S HP161193 HWH_ATT_Band_4 HP157193 HWH_ATT_Band_3 HP156193 HWH_ATT_Band_2 HP155193 HWH_ATT_Band_1 HP154193 HWH_ATT_IN HP153193 Subsch. ID : 70 Det. descr. : Configure WBS-H	HC032289 439287809 <dec> ON OFF (Def) 0 <dec> (Def) Levell 7 <dec> 7 <dec> 7 <dec> 7 <dec> 15 <dec>	
	ET=+ UT=+00.00.00	HIFI_Configure_WBS_V HIFI_Configure_WBS_V Command Parameter(s) : HIFI_BB_ID HP001197 HWV_LASER1_S HP168193 HWV_LASER2_S HP169193 HWV_Heater HP170193 HWV_Latchup_S HP171193 HWV_ATT_Band_4 HP167193 HWV_ATT_Band_3 HP166193 HWV_ATT_Band_2 HP165193 HWV_ATT_Band_1 HP164193 HWV_ATT_IN HP163193 Subsch. ID : 70 Det. descr. : Configure WBS-H	HC033289 439287809 <dec> ON OFF (Def) 0 <dec> (Def) Levell 7 <dec> 7 <dec> 7 <dec> 7 <dec> 15 <dec>	

HifiManCmdSetIntoDissipative_II - 5a
 File: H_FCP_HIF_2D5A.xls
 Author: R. Biggins



Step No.	Time	Activity/Remarks	TC/TLM	Display/ Branch
4		Go to Normal mode		Next Step: 5
	ET=+ UT=+00.00.01	HIFI_HL_Normal HIFI_HL_Normal Command Parameter(s) : HIFI_BB_ID HP001197 TC Control Flags : GBM IL DSE --Y -- --- Subsch. ID : 70 Det. descr. : Send single command to switch LCU to normal mode	HC082289 434241537 <dec>	
		Verify: HIFI mode HL_MODE_S HM258194	= normal	AND=ZAZ9C999
5		Set to dissipative band		Next Step: 6
	ET=+ UT=+00.00.00	Execute Telecommand HIFI_Conf_safe_LCU_ch5a Command Parameter(s) : HIFI_BB_ID HP001197 440205313 <dec> HL_freq_nx HP436194 30 <dec> HL_LSU_main HP438194 4062322160 <dec> HL_LSU_offset HP439194 4063329761 <dec> HL_D2_step HP437194 2 <dec> HL_Drain2_5A_V HP359194 1.13 V HL_Curlim2 HP291194 1.22 HL_macro_checksum HP440194 1 <dec> TC Control Flags : GBM IL DSE --Y -- --- Subsch. ID : 70 Det. descr. : Create macro-command to configure LCU band 5a to safe setting	HC058289	
	ET=+ UT=+00.00.20	HIFI_LCU_read_settings HIFI_LCU_read_settings Subsch. ID : 70 Det. descr. : Requests setting parameters from LCU RAM page 7A	HC198289	
	ET=+ UT=+00.00.00	HIFI_LCU_all_tuning_hk HIFI_LCU_all_tuning_hk Subsch. ID : 70 Det. descr. : Requests all five LCU intermediate housekeeping-sets	HC193289	
6		Set heaters to normal mode value		Next Step: 7

HifiManCmdSetIntoDissipative_II - 5a
 File: H_FCP_HIF_2D5A.xls
 Author: R. Biggins



Step No.	Time	Activity/Remarks	TC/TLM	Display/ Branch
	ET=+ UT=+00.00.01	HIFI_HL_heater HIFI_HL_heater Command Parameter(s) : HIFI_BB_ID HP001197 HL_heater HP397194 Subsch. ID : 70 Det. descr. : Send single command to control the LCU heater	HC086289 433520641 <dec> 4.0 V	
7		Switch to dissipative mode		Next Step: 8
	ET=+ UT=+00.00.00	HIFI_HL_dissipative HIFI_HL_dissipative Command Parameter(s) : HIFI_BB_ID HP001197 TC Control Flags : GBM IL DSE --Y -- --- Subsch. ID : 70 Det. descr. : Send single command to start dissipative mode	HC199289 434307073 <dec>	
		Verify: HIFI mode HL_MODE_S HM258194	= dissipative	AND=ZAZ9C999
		Verify Telemetry HL_Channel_S HM003194	= 5a	AND=ZAZ9C999
8		Set default OBSID/BBID		Next Step: END
	ET=+ UT=+00.00.00	HIFI_Set_OBS_ID HIFI_Set_OBS_ID Command Parameter(s) : HIFI_BB_ID HP001197 HIFI_OBS_ID HP000197 TC Control Flags : GBM IL DSE --Y -- --- Subsch. ID : 70 Det. descr. : Set Observation-ID and Building-Block-ID	HC014289 0 <hex> (Def) 0 <hex> (Def)	
		Verify Telemetry BB_ID_per_hk HM004190	= 0 <hex>	AND=ZAZ9C999
		Verify Telemetry OBS_ID_per_hk HM003190	= 0 <hex>	AND=ZAZ9C999
End of Procedure				