

PACS_SwOff_chopper_ast_OBS
 File: H_COP_PAC_CX03.xls
 Author: R. Biggins



Procedure Summary

Objectives

The objective of this procedure is to switch off the chopper controller

Based on procedure:
 PACS_SwOff_chopper_ast_OBS (v2)

Summary of Constraints

This procedure is to be executed upon request by the PACS instrument team

Spacecraft Configuration

Start of Procedure

n/a

End of Procedure

n/a

Reference File(s)

Input Command Sequences

Output Command Sequences

HCPCX03

Referenced Displays

ANDs GRDs SLDs

Configuration Control Information

DATE	FOP ISSUE	VERSION	MODIFICATION DESCRIPTION	AUTHOR	SPR REF
09/10/08	2	1	Created	R. Biggins	

PACS_SwOff_chopper_ast_OBS
File: H_COP_PAC_CX03.xls
Author: R. Biggins



Procedure Flowchart Overview

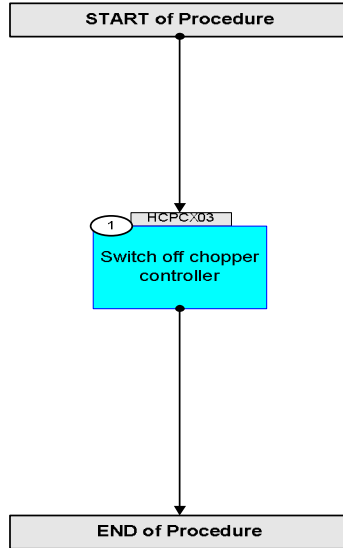

PACS_SwOff_chopper_ast_OBS
 File: H_COP_PAC_CX03.xls
 Author: R. Biggins



Step No.	Time	Activity/Remarks	TC/TLM	Display/ Branch
Beginning of Procedure				
<p><i>TC Seq. Name : HCPCX03 (Switch Off Chopper)</i></p> <p><i>TimeTag Type: B</i> <i>Sub Schedule ID:</i></p> <p style="text-align: center;">□</p>				
1		<i>Switch off chopper controller</i>		Next Step: END
	ET=+00.00.00 UT=+00.00.00	Execute Telecommand <div style="text-align: center;">DMC_SWOF_CHOP_CONT</div> <i>Subsch. ID : 90</i> <i>Det. descr. : SWITCH OFF CHOPPER CONTROLLER</i>	PC120420	
End of Procedure				