

PACS_Chopper_uk_move_3000_ast_OBS
 File: H_COP_PAC_C201.xls
 Author: R. Biggins



Procedure Summary

Objectives

The objective of this procedure is to perform rectangular chopping with step size of 3000 (move between chopper positions +3000 and -3000 with a plateau time of 2 sec and chop cycles of 10)

Based on procedure:
 PACS_Chopper_uk_move_3000_ast_OBS (v2)

Summary of Constraints

RT Science must be enabled to receive the Diagnostic HK packets

Spacecraft Configuration

Start of Procedure

PACS in NO_PRIME (SAFE) mode

End of Procedure

PACS in NO_PRIME (SAFE) mode

Reference File(s)

Input Command Sequences

Output Command Sequences

HCPC201

Referenced Displays

ANDs **GRDs** **SLDs**
 ZAZ98999

Configuration Control Information

DATE	FOP ISSUE	VERSION	MODIFICATION DESCRIPTION	AUTHOR	SPR REF
26/08/08	2	1	Created	R. Biggins	
20/04/09	2.3	1.01	Validation : Final updates before flight - Summary updated - TC flags updated	R. Biggins	

PACS_Chopper_uk_move_3000_ast_OBS
File: H_COP_PAC_C201.xls
Author: R. Biggins



Procedure Flowchart Overview

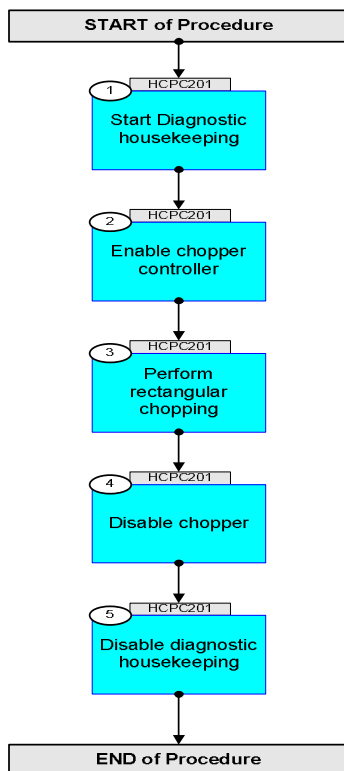

PACS_Chopper_uk_move_3000_ast_OBS
 File: H_COP_PAC_C201.xls
 Author: R. Biggins



Step No.	Time	Activity/Remarks	TC/TLM	Display/ Branch
Beginning of Procedure				
TC Seq. Name : HCPC201 (Chopper step 3000)				
TimeTag Type: B Sub Schedule ID: □				
1		Start Diagnostic housekeeping		Next Step: 2
	ET=+00.00.00 UT=+00.00.00	DMC_SET_BBID Command Parameter(s) : BUILDING_BLOCK_ID PP070420 TC Control Flags : Subsch. ID : 90 Det. descr. : SET BBID IN DMC	DMC_SET_BBID PC079420 41DA0001 <hex>	
	ET=+00.00.01 UT=+00.00.01	DMC_WRT_DIAG_HK_LIST Command Parameter(s) : DMC_DATA_LENGTH PP065420 DMC_4_BYTES_WORDS_DATA PP067420 DMC_4_BYTES_WORDS_DATA PP067420 DMC_4_BYTES_WORDS_DATA PP067420 DMC_4_BYTES_WORDS_DATA PP067420 DMC_4_BYTES_WORDS_DATA PP067420 DMC_4_BYTES_WORDS_DATA PP067420 DMC_CHECKSUM PP066420 SSID : 90	DMC_WRT_DIAG_HK_LIST PC160420 6 <dec> D1 <hex> F4 <hex> F5 <hex> 102 <hex> 231 <hex> FFFF <hex> 7D1C <hex>	
	ET=+00.00.00 UT=+00.00.00	DMC_START_DIAG_HK Command Parameter(s) : DIAG_HK_PERIOD PP076420 Subsch. ID : 90 Det. descr. : START THE ACQUISITION OF THE DIAGNOSTIC HK	DMC_START_DIAG_HK PC146420 0 <dec>	
		Verify Telemetry DM_BBID PM029420	= 41DA0001 <hex>	AND=ZAZ98999
		NOTE: The verification of the generation of the TM(21,3) diagnostic packets cannot be done on the MCS, but can be seen on the NCTRS (VC7)		
2		Enable chopper controller		Next Step: 3

PACS_Chopper_uk_move_3000_ast_OBS
 File: H_COP_PAC_C201.xls
 Author: R. Biggins



Step No.	Time	Activity/Remarks	TC/TLM	Display/ Branch
	ET=+00.00.01 UT=+00.00.01	DMC_ENABLE_CHOP_CONT DMC_ENABLE_CHOP_CONT TC Control Flags : Subsch. ID : 90 Det. descr. : ENABLE CHOPPER CONTROLLER GBM IL DSE --Y -- --	PC121420	
3		Perform rectangular chopping		Next Step: 4
		No telemetry checks are expected in this step, although the values of the BBID (PM029420) can be monitored to check that the value is increasing as expected.		
	ET=+00.00.05 UT=+00.00.05	DMC_SET_BBID DMC_SET_BBID Command Parameter(s) : BUILDING_BLOCK_ID PP070420 TC Control Flags : Subsch. ID : 90 Det. descr. : SET BBID IN DMC GBM IL DSE --Y -- --	PC079420 41630001 <hex>	
	ET=+00.00.01 UT=+00.00.01	DMC_MOVE_CHOP_ABS DMC_MOVE_CHOP_ABS Command Parameter(s) : SET_POINT PP079420 Subsch. ID : 90 Det. descr. : MOVE CHOPPER TO AN ABSOLUTE POSITION	PC123420 0 <dec>	
	ET=+00.00.01 UT=+00.00.01	DMC_SET_BBID DMC_SET_BBID Command Parameter(s) : BUILDING_BLOCK_ID PP070420 SSID : 90	PC079420 41630002 <hex>	
	ET=+00.00.01 UT=+00.00.01	DMC_MOVE_CHOP_ABS DMC_MOVE_CHOP_ABS Command Parameter(s) : SET_POINT PP079420 Subsch. ID : 90 Det. descr. : MOVE CHOPPER TO AN ABSOLUTE POSITION	PC123420 3000 <dec>	

PACS_Chopper_uk_move_3000_ast_OBS
 File: H_COP_PAC_C201.xls
 Author: R. Biggins



Step No.	Time	Activity/Remarks	TC/TLM	Display/ Branch
	ET=+00.00.02 UT=+00.00.02	DMC_SET_BBID DMC_SET_BBID Command Parameter(s) : BUILDING_BLOCK_ID PP070420 SSID : 90	PC079420 41630003 <hex>	
	ET=+00.00.01 UT=+00.00.01	DMC_MOVE_CHOP_ABS DMC_MOVE_CHOP_ABS Command Parameter(s) : SET_POINT PP079420 Subsch. ID : 90 Det. descr. : MOVE CHOPPER TO AN ABSOLUTE POSITION	PC123420 -3000 <dec>	
	ET=+00.00.02 UT=+00.00.02	DMC_SET_BBID DMC_SET_BBID Command Parameter(s) : BUILDING_BLOCK_ID PP070420 SSID : 90	PC079420 41630004 <hex>	
	ET=+00.00.01 UT=+00.00.01	DMC_MOVE_CHOP_ABS DMC_MOVE_CHOP_ABS Command Parameter(s) : SET_POINT PP079420 Subsch. ID : 90 Det. descr. : MOVE CHOPPER TO AN ABSOLUTE POSITION	PC123420 3000 <dec>	
	ET=+00.00.02 UT=+00.00.02	DMC_SET_BBID DMC_SET_BBID Command Parameter(s) : BUILDING_BLOCK_ID PP070420 SSID : 90	PC079420 41630005 <hex>	
	ET=+00.00.01 UT=+00.00.01	DMC_MOVE_CHOP_ABS DMC_MOVE_CHOP_ABS Command Parameter(s) : SET_POINT PP079420 Subsch. ID : 90 Det. descr. : MOVE CHOPPER TO AN ABSOLUTE POSITION	PC123420 -3000 <dec>	
	ET=+00.00.02 UT=+00.00.02	DMC_SET_BBID DMC_SET_BBID Command Parameter(s) : BUILDING_BLOCK_ID PP070420 SSID : 90	PC079420 41630006 <hex>	

PACS_Chopper_uk_move_3000_ast_OBS
 File: H_COP_PAC_C201.xls
 Author: R. Biggins



Step No.	Time	Activity/Remarks	TC/TLM	Display/ Branch
	ET=+00.00.01 UT=+00.00.01	DMC_MOVE_CHOP_ABS DMC_MOVE_CHOP_ABS Command Parameter(s) : SET_POINT PP079420 Subsch. ID : 90 Det. descr. : MOVE CHOPPER TO AN ABSOLUTE POSITION	PC123420 3000 <dec>	
	ET=+00.00.02 UT=+00.00.02	DMC_SET_BBID DMC_SET_BBID Command Parameter(s) : BUILDING_BLOCK_ID PP070420 SSID : 90	PC079420 41630007 <hex>	
	ET=+00.00.01 UT=+00.00.01	DMC_MOVE_CHOP_ABS DMC_MOVE_CHOP_ABS Command Parameter(s) : SET_POINT PP079420 Subsch. ID : 90 Det. descr. : MOVE CHOPPER TO AN ABSOLUTE POSITION	PC123420 -3000 <dec>	
	ET=+00.00.02 UT=+00.00.02	DMC_SET_BBID DMC_SET_BBID Command Parameter(s) : BUILDING_BLOCK_ID PP070420 SSID : 90	PC079420 41630008 <hex>	
	ET=+00.00.01 UT=+00.00.01	DMC_MOVE_CHOP_ABS DMC_MOVE_CHOP_ABS Command Parameter(s) : SET_POINT PP079420 Subsch. ID : 90 Det. descr. : MOVE CHOPPER TO AN ABSOLUTE POSITION	PC123420 3000 <dec>	
	ET=+00.00.02 UT=+00.00.02	DMC_SET_BBID DMC_SET_BBID Command Parameter(s) : BUILDING_BLOCK_ID PP070420 SSID : 90	PC079420 41630009 <hex>	
	ET=+00.00.01 UT=+00.00.01	DMC_MOVE_CHOP_ABS DMC_MOVE_CHOP_ABS Command Parameter(s) : SET_POINT PP079420 Subsch. ID : 90 Det. descr. : MOVE CHOPPER TO AN ABSOLUTE POSITION	PC123420 -3000 <dec>	

PACS_Chopper_uk_move_3000_ast_OBS
 File: H_COP_PAC_C201.xls
 Author: R. Biggins



Step No.	Time	Activity/Remarks	TC/TLM	Display/ Branch
	ET=+00.00.02 UT=+00.00.02	DMC_SET_BBID DMC_SET_BBID Command Parameter(s) : BUILDING_BLOCK_ID PP070420 SSID : 90	PC079420 4163000A <hex>	
	ET=+00.00.01 UT=+00.00.01	DMC_MOVE_CHOP_ABS DMC_MOVE_CHOP_ABS Command Parameter(s) : SET_POINT PP079420 Subsch. ID : 90 Det. descr. : MOVE CHOPPER TO AN ABSOLUTE POSITION	PC123420 3000 <dec>	
	ET=+00.00.02 UT=+00.00.02	DMC_SET_BBID DMC_SET_BBID Command Parameter(s) : BUILDING_BLOCK_ID PP070420 SSID : 90	PC079420 4163000B <hex>	
	ET=+00.00.01 UT=+00.00.01	DMC_MOVE_CHOP_ABS DMC_MOVE_CHOP_ABS Command Parameter(s) : SET_POINT PP079420 Subsch. ID : 90 Det. descr. : MOVE CHOPPER TO AN ABSOLUTE POSITION	PC123420 -3000 <dec>	
	ET=+00.00.02 UT=+00.00.02	DMC_SET_BBID DMC_SET_BBID Command Parameter(s) : BUILDING_BLOCK_ID PP070420 SSID : 90	PC079420 4163000C <hex>	
	ET=+00.00.01 UT=+00.00.01	DMC_MOVE_CHOP_ABS DMC_MOVE_CHOP_ABS Command Parameter(s) : SET_POINT PP079420 Subsch. ID : 90 Det. descr. : MOVE CHOPPER TO AN ABSOLUTE POSITION	PC123420 3000 <dec>	
	ET=+00.00.02 UT=+00.00.02	DMC_SET_BBID DMC_SET_BBID Command Parameter(s) : BUILDING_BLOCK_ID PP070420 SSID : 90	PC079420 4163000D <hex>	

PACS_Chopper_uk_move_3000_ast_OBS
 File: H_COP_PAC_C201.xls
 Author: R. Biggins



Step No.	Time	Activity/Remarks	TC/TLM	Display/ Branch
	ET=+00.00.01 UT=+00.00.01	DMC_MOVE_CHOP_ABS DMC_MOVE_CHOP_ABS Command Parameter(s) : SET_POINT PP079420 Subsch. ID : 90 Det. descr. : MOVE CHOPPER TO AN ABSOLUTE POSITION	PC123420 -3000 <dec>	
	ET=+00.00.02 UT=+00.00.02	DMC_SET_BBID DMC_SET_BBID Command Parameter(s) : BUILDING_BLOCK_ID PP070420 SSID : 90	PC079420 4163000E <hex>	
	ET=+00.00.01 UT=+00.00.01	DMC_MOVE_CHOP_ABS DMC_MOVE_CHOP_ABS Command Parameter(s) : SET_POINT PP079420 Subsch. ID : 90 Det. descr. : MOVE CHOPPER TO AN ABSOLUTE POSITION	PC123420 3000 <dec>	
	ET=+00.00.02 UT=+00.00.02	DMC_SET_BBID DMC_SET_BBID Command Parameter(s) : BUILDING_BLOCK_ID PP070420 SSID : 90	PC079420 4163000F <hex>	
	ET=+00.00.01 UT=+00.00.01	DMC_MOVE_CHOP_ABS DMC_MOVE_CHOP_ABS Command Parameter(s) : SET_POINT PP079420 Subsch. ID : 90 Det. descr. : MOVE CHOPPER TO AN ABSOLUTE POSITION	PC123420 -3000 <dec>	
	ET=+00.00.02 UT=+00.00.02	DMC_SET_BBID DMC_SET_BBID Command Parameter(s) : BUILDING_BLOCK_ID PP070420 SSID : 90	PC079420 41630010 <hex>	
	ET=+00.00.01 UT=+00.00.01	DMC_MOVE_CHOP_ABS DMC_MOVE_CHOP_ABS Command Parameter(s) : SET_POINT PP079420 Subsch. ID : 90 Det. descr. : MOVE CHOPPER TO AN ABSOLUTE POSITION	PC123420 3000 <dec>	

PACS_Chopper_uk_move_3000_ast_OBS
 File: H_COP_PAC_C201.xls
 Author: R. Biggins



Step No.	Time	Activity/Remarks	TC/TLM	Display/ Branch
	ET=+00.00.02 UT=+00.00.02	DMC_SET_BBID DMC_SET_BBID Command Parameter(s) : BUILDING_BLOCK_ID PP070420 SSID : 90	PC079420 41630011 <hex>	
	ET=+00.00.01 UT=+00.00.01	DMC_MOVE_CHOP_ABS DMC_MOVE_CHOP_ABS Command Parameter(s) : SET_POINT PP079420 Subsch. ID : 90 Det. descr. : MOVE CHOPPER TO AN ABSOLUTE POSITION	PC123420 -3000 <dec>	
	ET=+00.00.02 UT=+00.00.02	DMC_SET_BBID DMC_SET_BBID Command Parameter(s) : BUILDING_BLOCK_ID PP070420 SSID : 90	PC079420 41630012 <hex>	
	ET=+00.00.01 UT=+00.00.01	DMC_MOVE_CHOP_ABS DMC_MOVE_CHOP_ABS Command Parameter(s) : SET_POINT PP079420 Subsch. ID : 90 Det. descr. : MOVE CHOPPER TO AN ABSOLUTE POSITION	PC123420 3000 <dec>	
	ET=+00.00.02 UT=+00.00.02	DMC_SET_BBID DMC_SET_BBID Command Parameter(s) : BUILDING_BLOCK_ID PP070420 SSID : 90	PC079420 41630013 <hex>	
	ET=+00.00.01 UT=+00.00.01	DMC_MOVE_CHOP_ABS DMC_MOVE_CHOP_ABS Command Parameter(s) : SET_POINT PP079420 Subsch. ID : 90 Det. descr. : MOVE CHOPPER TO AN ABSOLUTE POSITION	PC123420 -3000 <dec>	
	ET=+00.00.02 UT=+00.00.02	DMC_SET_BBID DMC_SET_BBID Command Parameter(s) : BUILDING_BLOCK_ID PP070420 SSID : 90	PC079420 41630014 <hex>	

PACS_Chopper_uk_move_3000_ast_OBS
 File: H_COP_PAC_C201.xls
 Author: R. Biggins



Step No.	Time	Activity/Remarks	TC/TLM	Display/ Branch
	ET=+00.00.01 UT=+00.00.01	DMC_MOVE_CHOP_ABS DMC_MOVE_CHOP_ABS Command Parameter(s) : SET_POINT PP079420 Subsch. ID : 90 Det. descr. : MOVE CHOPPER TO AN ABSOLUTE POSITION	PC123420 3000 <dec>	
	ET=+00.00.02 UT=+00.00.02	DMC_SET_BBID DMC_SET_BBID Command Parameter(s) : BUILDING_BLOCK_ID PP070420 SSID : 90	PC079420 41630015 <hex>	
	ET=+00.00.01 UT=+00.00.01	DMC_MOVE_CHOP_ABS DMC_MOVE_CHOP_ABS Command Parameter(s) : SET_POINT PP079420 Subsch. ID : 90 Det. descr. : MOVE CHOPPER TO AN ABSOLUTE POSITION	PC123420 -3000 <dec>	
	ET=+00.00.02 UT=+00.00.02	DMC_SET_BBID DMC_SET_BBID Command Parameter(s) : BUILDING_BLOCK_ID PP070420 SSID : 90	PC079420 41630016 <hex>	
	ET=+00.00.01 UT=+00.00.01	DMC_MOVE_CHOP_ABS DMC_MOVE_CHOP_ABS Command Parameter(s) : SET_POINT PP079420 Subsch. ID : 90 Det. descr. : MOVE CHOPPER TO AN ABSOLUTE POSITION	PC123420 0 <dec>	
4		Disable chopper		Next Step: 5
	ET=+00.00.01 UT=+00.00.01	DMC_DISABLE_CHOP_CONT DMC_DISABLE_CHOP_CONT Subsch. ID : 90 Det. descr. : DISABLE CHOPPER CONTROLLER	PC122420	
5		Disable diagnostic housekeeping		Next Step: END

PACS_Chopper_uk_move_3000_ast_OBS
 File: H_COP_PAC_C201.xls
 Author: R. Biggins



Step No.	Time	Activity/Remarks	TC/TLM	Display/ Branch
	ET=+00.00.05 UT=+00.00.05	DMC_SET_BBID DMC_SET_BBID Command Parameter(s) : BUILDING_BLOCK_ID PP070420 Subsch. ID : 90 Det. descr. : SET BBID IN DMC	PC079420 41650001 <hex>	
	ET=+00.00.01 UT=+00.00.01	DMC_STOP_DIAG_HK DMC_STOP_DIAG_HK Subsch. ID : 90 Det. descr. : STOP THE ACQUISITION OF THE DIAGNOSTIC HK	PC147420	
		Verify Telemetry DM_BBID PM029420	= 41650001 <hex>	AND=ZAZ98999
		NOTE: The verification of the end of generation of the TM(21,3) diagnostic packets cannot be done on the MCS , but can be seen on the NCTRS (VC7)		
		Offline analysis is required by the ICC to analyse the behaviour of the chopper during the time that the chopper controller is enabled		
End of Procedure				