

IF Chain Functional Test
 File: H_COP_HIF_NIF4.xls
 Author: R. Biggins



Procedure Summary

Objectives

The objective of this procedure is to check the functionality of the IF chain up to the spectrometers.

- Set TM rate to 1 packet/s
- Initialise FPU
- Turn on shot noise for mixers
- Tune WBS
- Set TM rate to 4 packet/s

Based on procedure:
 HIFI-COP-1.2-IF_FT (v3)

Summary of Constraints

Real-time science packets should be enabled for downlink for HIFI analysis

Spacecraft Configuration

Start of Procedure

HIFI in STANDBY II or PRIMARY mode

End of Procedure

Reference File(s)

Input Command Sequences

Output Command Sequences

HCHNIF4

Referenced Displays

ANDs	GRDs	SLDs
ZAZ9C999		
HA038289		
HA039289		
ZAZ9D999		

Configuration Control Information

DATE	FOP ISSUE	VERSION	MODIFICATION DESCRIPTION	AUTHOR	SPR REF
31/10/08	2	1	Created	R. Biggins	
24/02/09		2	Updates due to SVT-2/SOVT-2 testing - Summary updated - WBS tuning lasers (step 5) changed to FP	R. Biggins	
24/02/09		3	Modification history updated due to MOIS error	R. Biggins	

IF Chain Functional Test
File: H_COP_HIF_NIF4.xls
Author: R. Biggins



24/02/09	2.1	4	Updates from D. Teyssier - HIFI_Tune_HRS TC added (step 5)	R. Biggins	
----------	-----	---	---	------------	--

IF Chain Functional Test
File: H_COP_HIF_NIF4.xls
Author: R. Biggins



Procedure Flowchart Overview

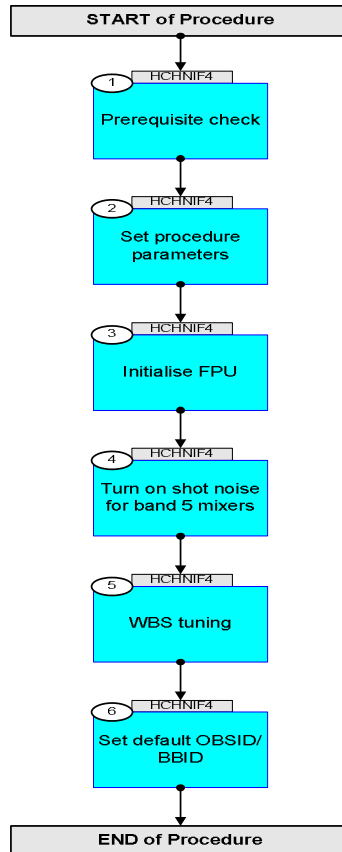

IF Chain Functional Test
 File: H_COP_HIF_NIF4.xls
 Author: R. Biggins



Step No.	Time	Activity/Remarks	TC/TLM	Display/ Branch
		HF_CH2_SIF3_Drain_V HP185191 HF_CH2_SIF3_Drain_C HP186191 HF_CV1_DPFP1 HP191191 HF_CV2_FIF1_Drain_V HP192191 HF_CV2_FIF1_Drain_C HP193191 HF_CV2_FIF2_Drain_V HP194191 HF_CV2_FIF2_Drain_C HP195191 HF_CV2_SIF1_Drain_V HP196191 HF_CV2_SIF1_Drain_C HP197191 HF_CV2_SIF2_Drain_V HP198191 HF_CV2_SIF2_Drain_C HP199191 HF_CV2_SIF3_Drain_V HP200191 HF_CV2_SIF3_Drain_C HP201191 HF_CPR_CH_SINE_S HP211191 HF_CPR_CH_LOOP_S HP210191 HF_CPR_CHFPG1 HP212191 HF_CPR_CHFPG2 HP213191 HF_CPR_CHFPZ1 HP214191 HF_CPR_CHFPZ2 HP215191 HF_CPR_CHFPP2 HP216191 HF_CPR_Cal_Heater_C HP217191 HF_CH1_MXBIAS_V HP172191 HF_CH1_MX_MG_C HP173191 HF_CV1_MXBIAS_V HP187191 HF_CV1_MX_MG_C HP188191 HF_P_Chopper_Rot HP454191 HF_CH1_DFACT_C HP174191 HF_CV1_DFACT_C HP189191	0.7 V 2.5 mA 227 <dec> (Def) 0.75 V 4.0 mA 0.65 V 3.0 mA 0.9 V 2.5 mA 0.75 V 1.9 mA 0.75 V 2.5 mA ON (Def) CLOSE (Def) 17 <dec> 201 <dec> 1010 <dec> 885 <dec> 149 <dec> 1.1 mA 1.780 mV 15.0 mA 1.780 mV 15.0 mA -1.07 V 1.555 mA 0.652 mA	
		Subsch. ID : 70		
		Det. descr. : Configure the FCU-subsystem (prime)		
	ET=+00.00.03 UT=+00.00.03	HIFI_CH1_MX_MG_C Command Parameter(s) : HIFI_BB_ID HP001197 HF_CH1_MX_MG_C HP173191 Subsch. ID : 70 Det. descr. : Send single command to set H mixer magnet current	HIFI_CH1_MX_MG_C HC096289 1C200001 <hex> 5.25 mA	
	ET=+00.00.00 UT=+00.00.00	HIFI_CV1_MX_MG_C Command Parameter(s) : HIFI_BB_ID HP001197 HF_CV1_MX_MG_C HP188191 Subsch. ID : 70 Det. descr. : Send single command to set V mixer magnet current	HIFI_CV1_MX_MG_C HC099289 1C200001 <hex> 5.3 mA	

IF Chain Functional Test
 File: H_COP_HIF_NIF4.xls
 Author: R. Biggins



Step No.	Time	Activity/Remarks	TC/TLM	Display/ Branch
		Verify: Verify the content of the following ANDs with the HIFI representative: HA038289 FCU_H_device HA039289 FCU_V_device HA042289 FCU_PR_power HA044289 FPU_common		
4		Turn on shot noise for band 5 mixers		Next Step: 5
	ET=+00.00.01 UT=+00.00.01	HIFI_CH1_MX_MG_C Command Parameter(s) : HIFI_BB_ID HP001197 HF_CH1_MX_MG_C HP173191 Subsch. ID : 70 Det. descr. : Send single command to set H mixer magnet current	HIFI_CH1_MX_MG_C HC096289 E3C0001 <hex> 0.0 mA (Def)	
	ET=+00.00.00 UT=+00.00.00	HIFI_CV1_MX_MG_C Command Parameter(s) : HIFI_BB_ID HP001197 HF_CV1_MX_MG_C HP188191 Subsch. ID : 70 Det. descr. : Send single command to set V mixer magnet current	HIFI_CV1_MX_MG_C HC099289 E3C0001 <hex> 0.0 mA (Def)	
		Verify Telemetry HF_AH1_MXMG_C HM040191	= 0.0 mA	AND=HA038289
		Verify Telemetry HF_AV1_MXMG_C HM131191	= 0.0 mA	AND=HA039289
	ET=+00.00.01 UT=+00.00.01	HIFI_CH1_MXBIAIS_V Command Parameter(s) : HIFI_BB_ID HP001197 HF_CH1_MXBIAIS_V HP172191 Subsch. ID : 70 Det. descr. : Send single command to set H mixer bias voltage	HIFI_CH1_MXBIAIS_V HC095289 0 <hex> (Def) 5.0 mV	
	ET=+00.00.00 UT=+00.00.00	HIFI_CV1_MXBIAIS_V Command Parameter(s) : HIFI_BB_ID HP001197 HF_CV1_MXBIAIS_V HP187191 Subsch. ID : 70 Det. descr. : Send single command to set V mixer bias voltage	HIFI_CV1_MXBIAIS_V HC098289 0 <hex> (Def) 5.0 mV	

IF Chain Functional Test
 File: H_COP_HIF_NIF4.xls
 Author: R. Biggins



Step No.	Time	Activity/Remarks	TC/TLM	Display/ Branch
	ET=+00.00.01 UT=+00.00.01	HIFI_Tune_WBS HIFI_Tune_WBS Command Parameter(s) : HIFI_BB_ID HP001197 HIF_WBS_tune_target HP074197 Subsch. ID : 70 Det. descr. : Find optimal setting for WBS attenuators	HC144289 E130001 <hex> 80 <dec>	
	ET=+00.00.10 UT=+00.00.10	Execute Telecommand HIFI_Tune_HRS Command Parameter(s) : HIFI_BB_ID HP001197 Subsch. ID : 70 Det. descr. : Find optimal setting for HRS attenuators	HC143289 E110001 <hex>	
	ET=+00.00.10 UT=+00.00.10	HIFI_config_spectroscopy HIFI_config_spectroscopy Command Parameter(s) : HIFI_BB_ID HP001197 HIF_N_WBS_START HP021197 HIF_R_HRS HP022197 HIF_N_WBS_INTEGR HP023197 HIF_N_HRS_INTEGR HP024197 HIF_DEL_HRS HP025197 HIF_DEL_WBS HP026197 HIF_T_ACC_WBS HP027197 HIF_T_ACC_HRS HP028197 HIF_WBSH_OFFSET1 HP029197 HIF_WBSH_WIDTH1 HP030197 HIF_WBSH_OFFSET2 HP031197 HIF_WBSH_WIDTH2 HP032197 HIF_WBSH_OFFSET3 HP033197 HIF_WBSH_WIDTH3 HP034197 HIF_WBSH_OFFSET4 HP035197 HIF_WBSH_WIDTH4 HP036197 HIF_WBSV_OFFSET1 HP037197 HIF_WBSV_WIDTH1 HP038197 HIF_WBSV_OFFSET2 HP039197 HIF_WBSV_WIDTH2 HP040197 HIF_WBSV_OFFSET3 HP041197 HIF_WBSV_WIDTH3 HP042197 HIF_WBSV_OFFSET4 HP043197 HIF_WBSV_WIDTH4 HP044197 HIF_HRS_RSHIFT HP045197	HC150289 0 <hex> (Def) 4 <dec> 1 <dec> (Def) 4 <dec> 4 <dec> 2 <dec> 4 <dec> 945 <dec> 929 <dec> 36 <dec> 1976 <dec> 2084 <dec> 1976 <dec> 4132 <dec> 1976 <dec> 6180 <dec> 1976 <dec> 36 <dec> 1976 <dec> 2084 <dec> 1976 <dec> 4132 <dec> 1976 <dec> 6180 <dec> 1976 <dec> 0 <dec> (Def)	

IF Chain Functional Test
 File: H_COP_HIF_NIF4.xls
 Author: R. Biggins



Step No.	Time	Activity/Remarks	TC/TLM	Display/ Branch
		HIF_WBS_RSHIFT HP046197 HIF_HRSH_SEL HP047197 HIF_HRSV_SEL HP048197 HIF_WBS_packing HP049197 TC Control Flags : GBM IL DSE ---- Subsch. ID : 70 Det. descr. : Specify parameters for next spectroscopy measurement	3 <dec> 255 <dec> (Def) 255 <dec> (Def) 16_bits_format	
	ET=+00.00.00 UT=+00.00.00	HIFI_Spectr_total_power HIFI_Spectr_total_power Command Parameter(s) : HIFI_BB_ID HP001197 Subsch. ID : 70 Det. descr. : Start total-power spectroscopy measurement	HC151289 E160001 <hex>	
	ET=+00.00.07 UT=+00.00.07	HIFI_Housekeeping_on HIFI_Housekeeping_on Command Parameter(s) : HIF_HK_rate HP012197 HIF_FCU_S HP006197 HIF_LCU_S HP007197 HIF_WBSV_S HP009197 HIF_WBSH_S HP008197 HIF_HRSV_S HP011197 HIF_HRSH_S HP010197 Subsch. ID : 70 Det. descr. : Sets periodic housekeeping packet generation period	HC016289 1_pkt_per_4_s ON (Def) ON (Def) ON (Def) ON (Def) ON (Def) ON (Def)	
		Verify: The following TM(3,25) packets should be produced once every 4 seconds: HIFI_essential_HK (APID 1024) HIFI_HK_rev_7 (APID 1026)		
6		Set default OBSID/BBID		Next Step: END
	ET=+00.00.01 UT=+00.00.01	HIFI_Set_OBS_ID HIFI_Set_OBS_ID Command Parameter(s) : HIFI_BB_ID HP001197 HIFI_OBS_ID HP000197 Subsch. ID : 70 Det. descr. : Set Observation-ID and Building-Block-ID	HC014289 0 <hex> (Def) 0 <hex> (Def)	

IF Chain Functional Test
 File: H_COP_HIF_NIF4.xls
 Author: R. Biggins



Step No.	Time	Activity/Remarks	TC/TLM	Display/ Branch
		Verify Telemetry BB_ID_per_hk HM004190	= 0 <hex>	AND=ZAZ9C999
		Verify Telemetry OBS_ID_per_hk HM003190	= 0 <hex>	AND=ZAZ9C999
End of Procedure				