document title/ *titre du document*

VMC FOR MEX

FLIGHT USER MANUAL

prepared by/*préparé*
par

reference/*référence* **MEX-ESA-VMC-MA-0003**

issue/*édition* 4

revision/*révision* 2

date of issue/*date* **17 January 2003**
d'édition

status/*état*

Document type/*type* Technical Note

a

ESTEC

TOS-ETD Data and Image Processing Section, Payload Systems
Division

Keplerlaan 1 - 2201 AZ Noordwijk - The Netherlands

Tel. (31) 71 5656565 - Fax (31) 71 5656040

MEX-ESA-VMC-MA-0003 4.2
VMC Flight User Manual 2003
Jan17

S

de document
Distribution/*distribution*

A P P R O V A L

Title <i>titre</i>	VMC Flight User Manaul	iss 4 ue iss ue	revisio 0 n revisio n
-----------------------	------------------------	--------------------------	--------------------------------

author <i>auteur</i>	David Jameux (TOS-ETD)	dat 07/11/02 e dat e
-------------------------	------------------------	-------------------------------

approved by <i>approuvé by</i>	HansEggel (SCI-PE)	dat e dat e
-----------------------------------	--------------------	----------------------

C H A N G E L O G

reason for change / <i>raison du changement</i>	issue/ <i>issue</i>	revision/ <i>revisio n</i>	date/ <i>date</i>
Timeline	1	1	19-09-00
Timeline	1	2	22-09-00
Document lay-out	1	3	13-11-00
ICDR RID's			
ESOC (Erhardt Rabenau, TOS-OGM) comments	4	0	07/11/2002

C H A N G E R E C O R D

ISSUE: **2**REVISION: **1**

reason for change/ <i>raison du changement</i>	page(s)/ <i>page(s)</i>	paragraph(s)/ <i>para graph(s)</i>
Timeline	8 - 11	
Timeline	10-11	
Document lay-out	all	
ICDR RID's		

CHANGE RECORD

ISSUE: 4 REVISION: 1

reason for change/ <i>raison du changement</i>	page(s)/ <i>page(s)</i>	paragraph(s)/ <i>paragraph(s)</i>
Mistake in VMC attitude description	9	1.4 modified
No action can be taken against latch-up since operations are off-line.	55 and 74	last paragraph of 5.2 moved to 8.
VMC procedures for SVT, EV, IC and Beagle2 separation were not clear	65-73	6.1 appended and structured
The role of the VMC "PI" was not clear	75	6.1.3 added
Maximal operating temperature was wrong in the definition of coloured HK checks	12	3.1

T A B L E O F C O N T E N T S

1	INTRODUCTION.....	11
1.1	OBJECTIVES OF MEX VMC	11
1.2	FUNCTIONS OF THE VMC	11
1.3	DESCRIPTION OF THE VMC.....	11
1.4	OPERATIONAL PRINCIPLE	11
2	REFERENCE DOCUMENTS	12
3	VMC DESCRIPTION.....	12
3.1	VMC CAMERA CONFIGURATION FOR MARS EXPRESS.....	12
3.2	OPTICAL DESIGN.....	15
3.2.1	DESIGN DESCRIPTION.....	15
3.2.2	COATINGS.....	17
3.2.3	IMAGE QUALITY	20
3.2.3.1	MTF.....	20
3.2.3.2	ENCIRCLED ENERGY	23
3.2.3.3	DEFINITION OF PASSBAND FILTER	23
3.2.3.4	DISTORTION AND FIELD CURVATURE	23
3.2.4	THERMAL ANALYSIS	25
3.2.5	STRAYLIGHT ANALYSIS	27
3.2.6	TOLERANCE ANALYSIS.....	28
3.3	MECHANICAL DESIGN.....	30
3.3.1	MECHANICAL DESIGN DESCRIPTION	30
3.3.1.1	THE OBJECTIVE ASSEMBLY	31
3.3.1.2	THE DETECTOR ASSEMBLY	33
3.3.1.3	THE CAMERA ASSEMBLY	35
3.3.1.4	THE BAFFLE.....	38
3.4	ELECTRICAL DESIGN FOR IRIS VMC	39
3.4.1	CAMERA MODULE OVERVIEW	39
3.4.2	CONVENTIONS.....	39
3.4.3	ELECTRICAL INTERFACES.....	41
3.4.3.1	POWER SUPPLY	41
3.4.3.1.1	POWER INTERFACE	41
3.4.3.1.2	POWER CONVERTER SHUTDOWN, INHIBITB FUNCTION	41
3.4.3.1.3	POWER SUPPLY BLOCK DIAGRAM	42
3.4.3.1.4	POWER RELAY CONTROL	42

3.4.3.2	DATA INTERFACE	43
3.4.3.2.1	SYNCHRONOUS SERIAL COMMAND INPUT	43
3.4.3.2.2	SYNCHRONOUS SERIAL DATA OUTPUT	45
3.4.3.2.3	SYNCHRONOUS INTERFACE COMPLIANCE WITH [RD4]	47
3.4.3.2.4	ON-BOARD THERMISTOR	47
3.4.3.2.5	COMMAND/DATA INTERFACE CONNECTOR SPECIFICATION	48
3.4.3.2.6	COMMAND/DATA INTERFACE ELECTRICAL CIRCUIT DESCRIPTIONS	49
3.5	EMC AND PP INTERFACE COMPLIANCE	50
3.5.1	PRIMARY POWER SUPPLY INTERFACE, ELECTRICAL ISSUES	50
3.5.2	CONDUCTED EMISSIONS ON PRIMARY POWER, FREQUENCY DOMAIN	50
3.5.3	CE ON SIGNAL LINES	50
3.5.4	RADIATED INTERFERENCE	50
3.6	VMC HARDWARE GROUNDING LAYOUT	51
3.7	POWER CONSUMPTION PROFILE	51
3.8	SENSOR SPECIFICATIONS	52
4	CAMERA CONFIGURATIONS VMC FOR MEX.....	53
4.1	SYSTEM CONFIGURATION	53
4.1.1	OPERATIONAL MODE	54
4.1.2	DEFAULT EXPOSURE TIME.....	55
4.1.3	TRIGGERED SNAPSHOT	55
5	FUNCTIONAL SPECIFICATION	57
5.1	INTERNAL STATES, VARIABLES AND DEFAULT VALUES.....	57
5.2	VMC START-UP, SYSTEM RESET, INITIAL STATE, SENSOR POWER MONITORING	57
5.3	FIRST IMAGE AFTER START-UP	58
5.4	COMMANDS: FORMAT, OVERVIEW, AND HANDLING.....	58
5.4.1	COMMAND STRUCTURE.....	58
5.4.2	GENERAL OPERATION: COMMANDS, COMMAND ABORTION, IMAGE DOWNLOAD	59
5.5	RESET COMMAND.....	60
5.6	CAMERA PARAMETER SETTING COMMANDS.....	60
5.6.1	VMC-MODE SETTING	60
5.6.2	VMC INTERACTIVE EXPOSURE CONTROL	61
5.7	IMAGE ACQUISITION COMMANDS AND DATA FORMATS.....	63

5.7.1	IMAGE ACQUISITION, AUTOMATIC IMAGE UPDATE, IMAGE BUFFER READOUT	63
5.7.2	IMAGE OUTPUT DATA FORMAT	63
5.8	TRANSMISSION OF THE VMC DATA TO THE GROUND PROCESSING UNIT.	64
6	OPERATIONS PROCEDURES	65
6.1	VMC OPERATIONS TIMELINE ON MARS EXPRESS	65
6.1.1	TASK SHARING BETWEEN GROUND & DMS S/W	65
6.1.2	TYPICAL OPERATIONS SCENARIO	67
6.1.2.1	SYSTEM VALIDATION TESTS ACTIVITIES	67
6.1.2.2	EARTH VERIFICATION ACTIVITIES	70
6.1.2.3	INTERPLANETARY CRUISE ACTIVITIES	72
6.1.2.4	PREPARATION ACTIVITIES FOR BEAGLE2 SEPARATION	75
6.1.2.5	BEAGLE2 SEPARATION ACTIVITIES	76
6.1.3	ROLE OF THE VMC "PI"	81
6.2	OPERATION OF THE VMC CAMERA SYSTEM	81
6.2.1	COMMANDS TO THE VMC CAMERA	81
7	SUMMARY OF TELECOMMAND AND TELEMETRY DATA	86
7.1	TELECOMMAND LIST	86
7.2	TELEMETRY LIST	87
8	VMC SCOE DESCRIPTION AND OPERATION	88
8.1	THE VMC SCOE	88
8.2	THE VMC SCOE SOFTWARE	88
8.3	MEX VMC GROUND PROCESSING OPERATION	90
8.3.1	VMC DATA PROCESSING	90
8.3.2	OFF-LINE IMAGE PROCESSING	98
9	APPENDIX A: MECHANICAL LAYOUT	100
10	APPENDIX B: TRANSFER FRAMES AND VMC DATA FIELD LAY-OUT	101
10.1	TRANSFER FRAMES AND VMC DATA FIELD LAY-OUT	101
10.2	DATA FIELD LAY-OUT FOR VMC IMAGE DATA	102

11 **APPENDIX C: VMC CIRCUIT SCHEMATICS..... 103**

ACRONYMS AND ABBREVIATIONS

ADC	Analogue to Digital Converter
APID	Application Process ID
APS	Active Pixel Sensor
AR	Anti Reflection coating
BMP	Bitmap
CADU	Channel Access Data Unit
CCD	Charge Coupled Device
CCSDS	Consultative Committee for Space Data Systems
CE	Conducted Emissions (EMC)
CDMU	Configuration and Data Management Unit
CMOS	Complementary Metal Oxide Semiconductor
COG	Centre of Gravity
CS	Conducted Susceptibility
DDID	
DMS	Data Management System
EMC	Electro-Magnetic Compatibility
ESA	European Space Agency
F / #	F- number
FF	Fill Factor
FOV	Field Of View
FPA	Focal Plane Array
FWHM	Full Width at Half Maximum
HK TLM	Housekeeping Telemetry
IF	Interface
IMEC	Inter-university Micro-Electronics Centre
IRIS	Integrated Radiation tolerant Imaging System
IRIS-1	Prototype IRIS image sensor with off-chip control logic
IRIS-2	End-product IRIS image sensor with on-chip control logic
kb/s	kilo-bits per second
Kbps	kilo bits per second
kilo	one thousand
kps	kilo pixels per second
LAN	Local Area Network
LCL	Latching Current Limiter to power-cycle outputs of the S/C
LSB	Least Significant Bit
Mega	one million
Mb/s	Mega-bits per second
MB/s	Mega-bytes per second
MGSE	Mechanical Ground Support Equipment
ML/DS	Memory Load / Data Store
Mps	Mega pixels per second
MSB	Most Significant Bit

MTF	Modulation Transfer Function
MTL	Master Time Line
NCTRS	Network Control and Telemetry Routing System
OBDH	On Board Data Handling subsystem
OPSLAN	Operations system LAN
PCB	Printed Circuit Board
PP	Primary Power (from S/C)
QE	Quantum Efficiency
RTU	Remote Terminal Unit
S/C	Spacecraft
SEU	Single Event Upset
SID	Structure Identifier
SNR	Signal to Noise Ratio
SP	Secondary Power
SSMM	Solid State Mass Memory
T	Temperature
TBA	To Be Assessed
TBC	To Be Confirmed
TC	Telecommand
TM, TLM	Telemetry
TBC	To be confirmed
TBD	To be decided
TS	Trigger Signal pin selectable delay time
TSC	Trigger Signal Custom hardwired delay time
TV	Thermal Vacuum
VC3	Virtual Channel 3
VMC	Visual Monitoring Camera
VTS	Visual Telemetry System

1 INTRODUCTION

1.1 *Objectives of MEX VMC*

The Visual Monitoring Camera (VMC) is a stand-alone digital camera installed on board the Mars Express spacecraft in order to take snapshots in colour of the Mars Lander, "Beagle2", during separation and possibly later (with a view of the planet Mars if possible) for PR purposes.

1.2 *Functions of the VMC*

The VMC accepts image capture and exposure control commands, performs image acquisition, and can store in the baseline configuration one image in a local memory buffer to facilitate asynchronous readout at a low data rate.

1.3 *Description of the VMC*

The optical and mechanical parts were designed, manufactured, aligned and integrated by DSS (OIP). The detector was provided by IMEC. The electrical part was designed by IMEC and the PCB soldering and integration in the mechanical housing were done by DSS (OIP).

The Visual Monitoring Camera (VMC) is physically connected to the Mars Orbiter spacecraft, and electrically connected to the RTU by means of a ML/DS interface. The VMC can be controlled by means of separate sets of Telecommands.

1.4 *Operational principle*

The camera will be used during the transfer to Mars for instrument check-out and just before Beagle-separation when other payload instruments are switched off.

The location of the cameras inside the MEX Orbiter is as described in [RD3] and recalled in appendix A. The camera will look along the +Z axis (with an inclination of 19°) through an aperture in the upper panel where it has a view on the underside of the Beagle2 probe and watches it drifting away after separation. Sun illumination will determine the to-be-programmed exposure settings.

A first image (with default hardwired exposure settings) is always acquired 150 seconds after VMC Power-On. After this first image, the VMC system offers commanding capability i.e., e.g. immediately after verification of good reception of the first image, the possibility to acquire another series of images. Each image is kept in the VMC buffer until it is read out by the RTU for storage in the MEX-mass memory (for later telemetry to the ground).

Since the signal travel time to the spacecraft is in the order of 10 minutes a means must be set up to ensure image acquisition at Beagle-separation. Image acquisition and read-out must be done in a loop of a limited number of iterations to provide a sequence of images of the Beagle separating and drifting away from the spacecraft.

After downlink of these (framed) images from the on-board Solid State Mass Memory to the ground, the frames will be distributed to the VMC SCOE for image retrieval and processing.

2 REFERENCE DOCUMENTS

[RD 1] MARS EXPRESS Space/Ground I/F. Control Doc., ME-ESC-IF-5001, issue 2, 20-12-1999.

[RD 2] Visual Monitoring Camera: DESIGN DESCRIPTION, RE-VMC-001-OIP/98, iss 4, 3-10-2000.

[RD3] Spacecraft MICD-A, MEX-MMT-IF-0349, issue 1, 30-5-2000.

[RD4] XMM Electrical Interface Requirement ,XM-IF-DOR-0001, issue 5, 26-8-97.

[RD5] VMC TM/TC ICD, MEX-MMT-RP-0221, iss 4/0, 12-12-00

[RD6] VMC for MEX EICD, MEX-ESA-VMC-IF-0001, issue 2/0, 20-12-00

[RD7] DDID

3 VMC DESCRIPTION

3.1 *VMC Camera Configuration for Mars Express*

The VMC camera consists of a camera objective, an array detector (called IRIS and delivered by IMEC), a camera housing and a camera mount option. An overview of the camera is shown in fig. 3.1.

The system is designed to meet the following requirements :

◆ *Optical*

focal length: 12.3 mm

F/#: 5
 FOV: 40° x 31°
 Wavelength range: 400 - 650 nm (colour version) / 570 - 740 nm (black & white)

◆ **Environmental**

⇒ Mechanical : The vibration levels are summarised in table 3.1 and table 3.2

Table 3.1: Vibration levels : Sine vibration:

axis	Frequency (Hz)	Displacement (mm peak)	acceleration (g)	Velocity (mm/s)
x	5 - 19	10		
	19 - 26			1200
	26 - 100		20 g	
y , z	5 - 16	10		
	16 - 100		10 g	

Table 3.2: Vibration levels: Random

axis	Frequency (Hz)	Amplitude (g ² /Hz)	Slope (dB/oct)
x	20 - 80		+ 6 dB / oct
	80 - 130	0.5	
	130 - 2000		- 6 dB / oct
y , z	20 - 100		+6 dB / oct
	100 - 400	0.1	
	400 - 2000		-6 dB / oct

⇒ Thermal :

operational and non - operational T range: - 50°C - + 65°C

The temperature will be checked according to the following scheme:

T < -50°C	RED
-50°C < T < -45°C	YELLOW
-45°C < T < +60°C	GREEN
+60°C < T < +65°C	YELLOW
+65°C < T	RED

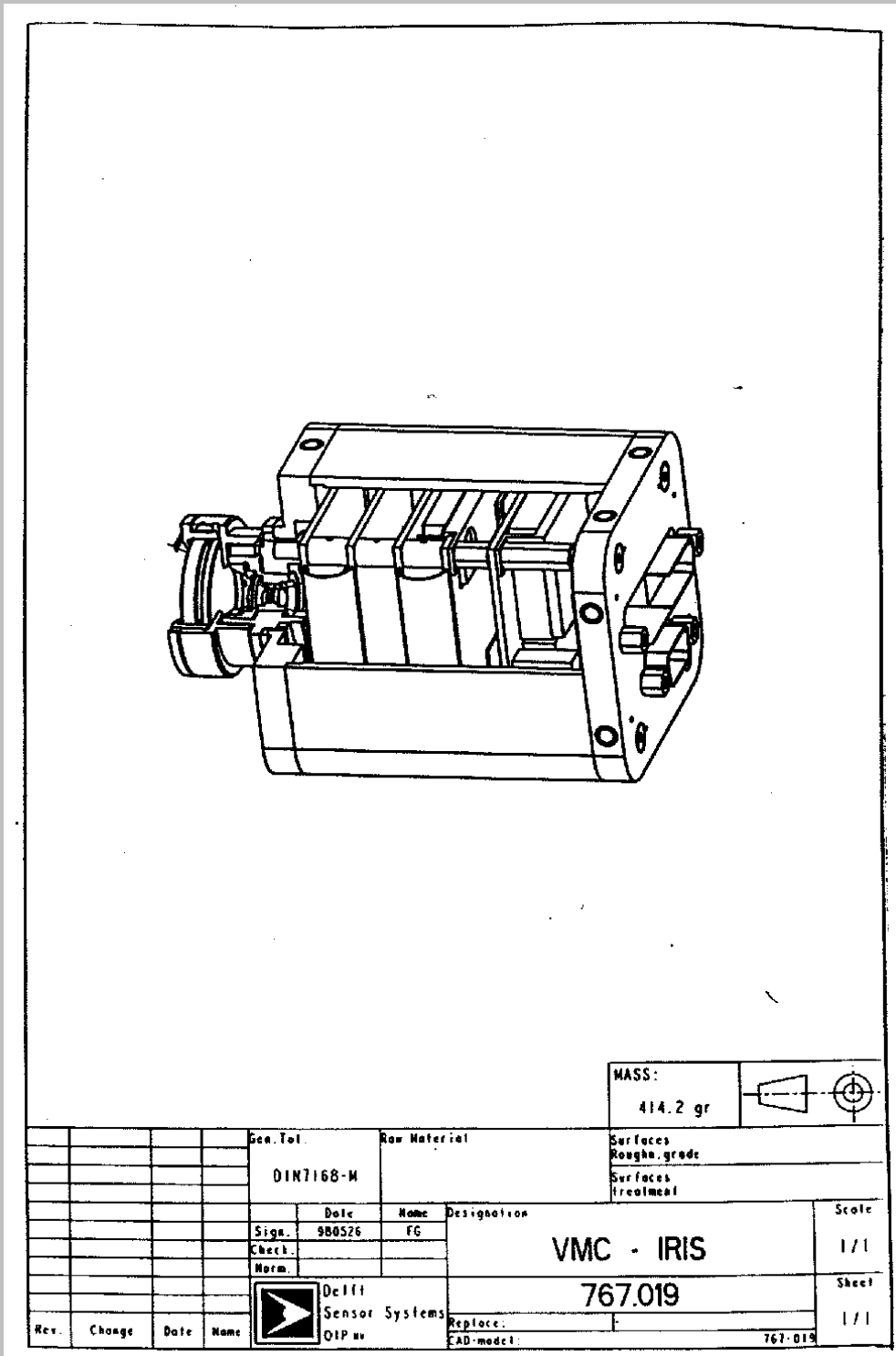

Figure 3.1.

3.2 *Optical Design*

3.2.1 DESIGN DESCRIPTION

The objective of the VMC camera consists of three lenses, made of suprasil 1, and a detector window, also made of suprasil. The camera objective is shown in fig. 3.2.

The system is designed to operate in the operational temperature range under vacuum conditions.

During the optical design of the system, the following important design drivers were followed:

- The spotsize should correspond as much as possible to the detector pixel size (14 x 14 μm^2). The F/# of 5 corresponds to a diffraction spot having a diameter of 9 μm (first dark circle of Airy disk).
- The objective should have a large depth of focus. The large F/# makes it possible to have sharp images between 3 meter and infinity without the need to refocus the objective. For image distances smaller than 3 meter the image quality degrades slowly. At a distance of 1 meter for example, the spot size is increased to 25 x 25 μm .

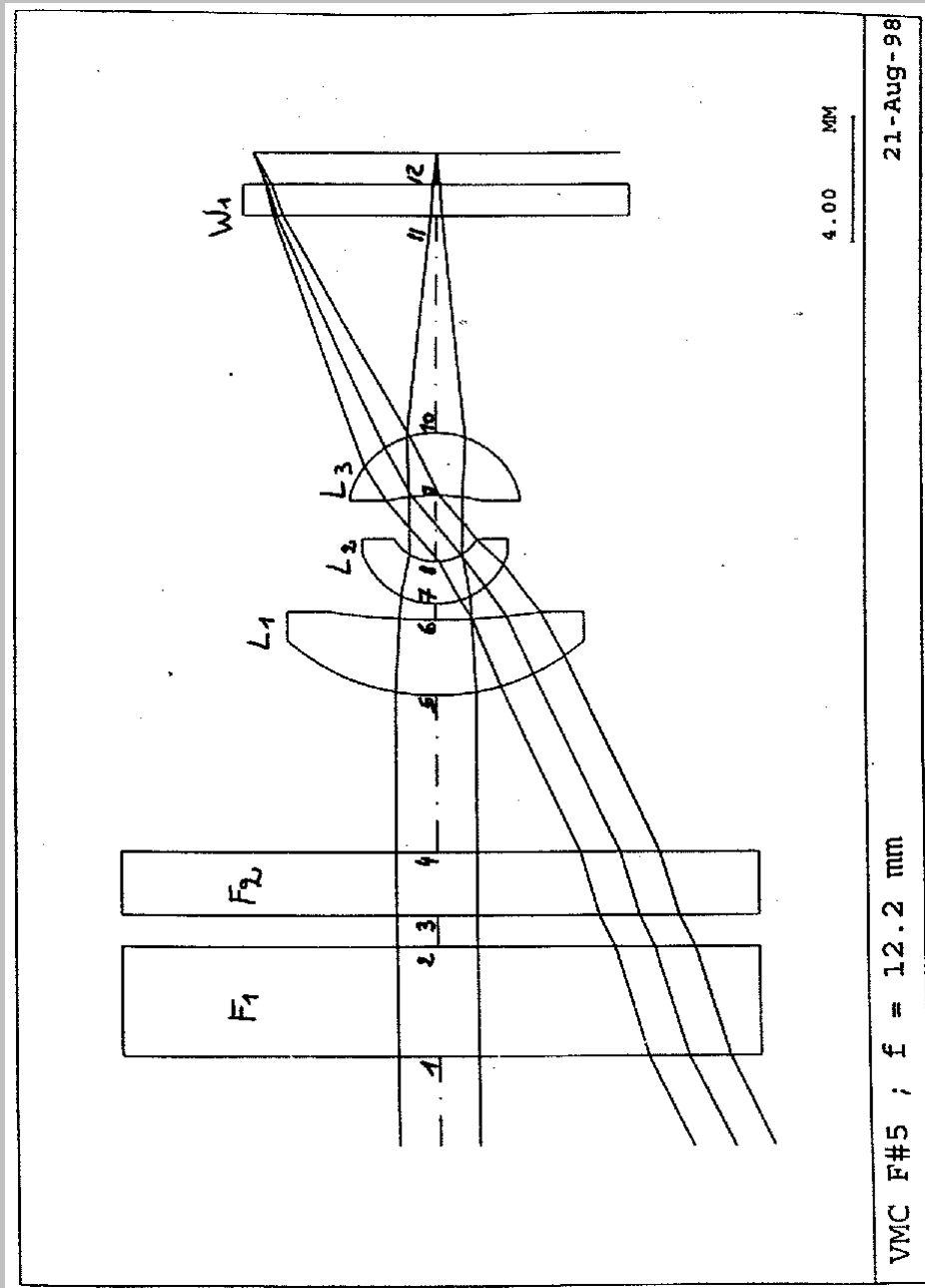

Figure 3.2

3.2.2 COATINGS

On all the optical surfaces, except on the front surface of filter F1, an AR coating is applied (see fig. 3.2). The reflectivity of the AR coatings is smaller than 0.5 % in the spectral range of interest.

The IR blocking filter has spectral characteristics as shown in fig 3.3. It is applied at the second surface of the first window of the objective. The first surface is not coated.

The transmission of the total optical system, including the filter stack, is shown in table 3.3 and in fig. 3.4.

Table 3.3

Calculation of transmission at 400 - 740 nm					
Component	Surface n°	Thickness	Glass	Bulk Absorption	Transmission Interface
F1	1	3.5	BK7G18	1.000	0.9575
	2				0.9
L1	5	2.5	Suprasil	1.000	0.995
	6				0.995
L2	7	1.23	Suprasil	1.000	0.995
	8				0.995
L3	9	2.6	Suprasil	1.000	0.995
	10				0.995
W1	11	1	Suprasil	1.000	0.995
	12				
				TOTAL :	0.745

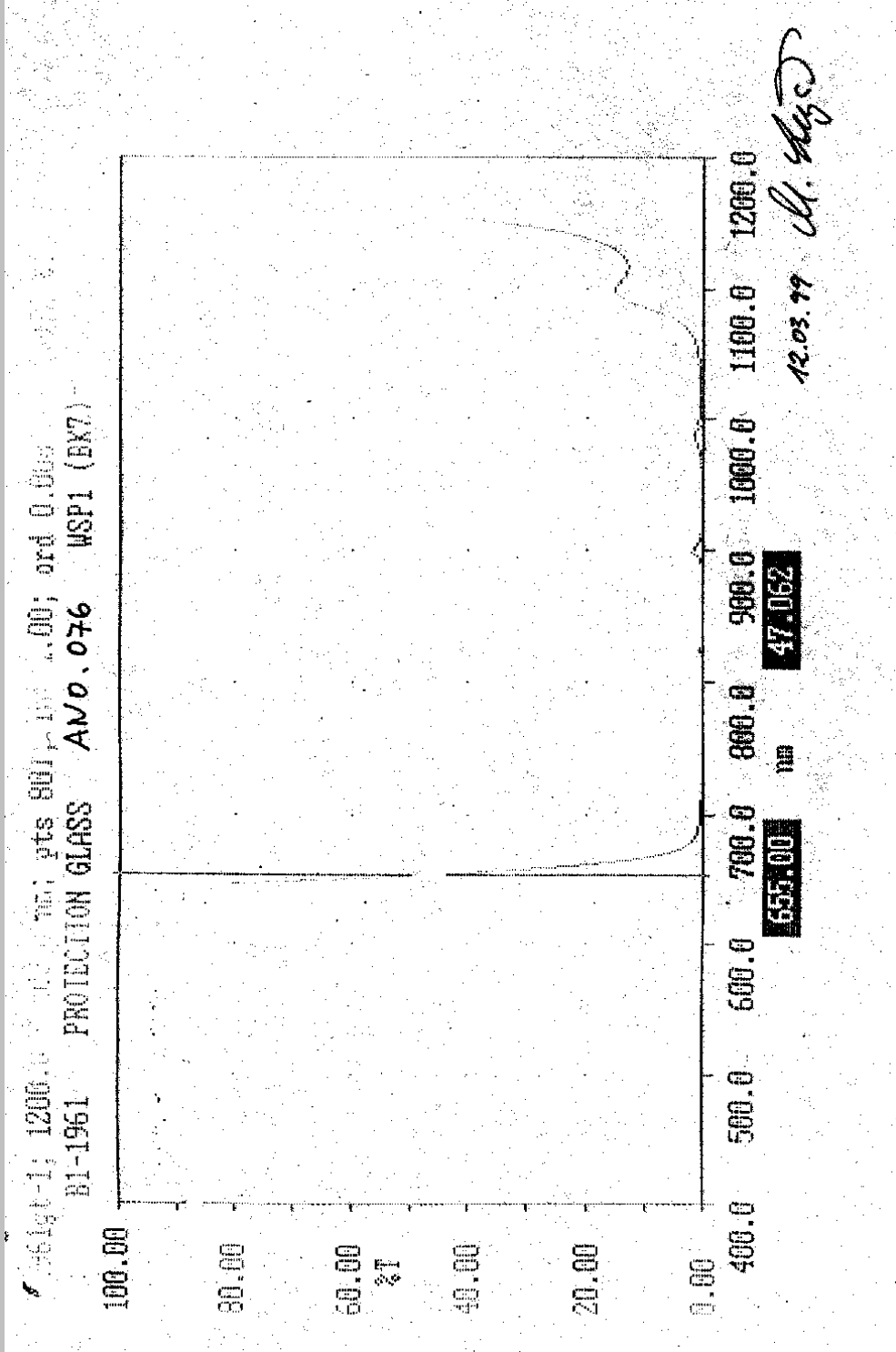

Figure 3.3

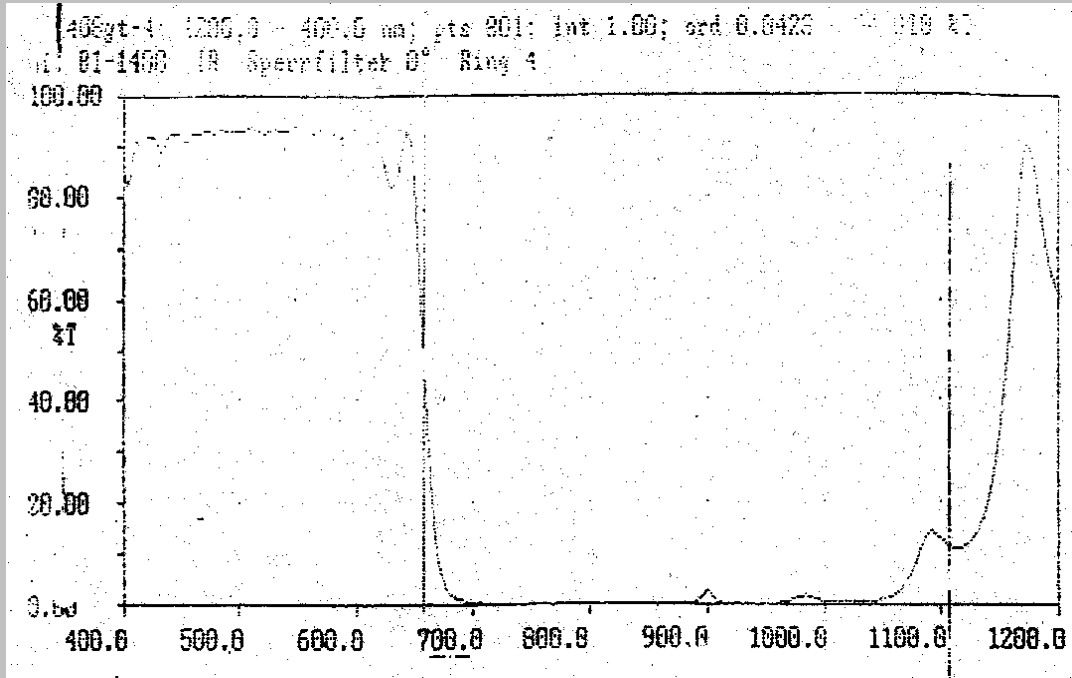

Figure 3.4 a : colour camera

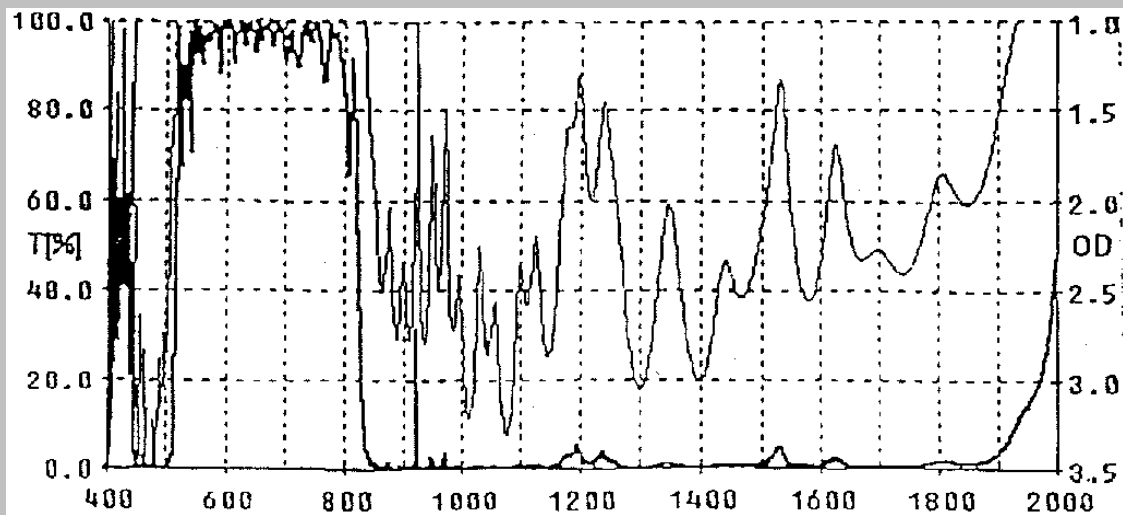

Figure 3.4 b : B&W camera

3.2.3 IMAGE QUALITY

3.2.3.1 MTF

The MTF curves of the VMC objectives are shown in fig. 3.5 and fig. 3.6 for objects placed at a distance of 3 meter and at infinity.

MTF values for object positions at infinity are listed in table 3.4.

The MTF calculations are performed at different field values within the FOV of the camera in the wavelength range between 500 and 800 nm.

The MTF is calculated at frequencies from 0 to 40 cycles/mm, corresponding to the detector pixel dimensions.

Sharp images can be obtained for objects at 3 meter and at infinity. For this object distance range there is no need to refocus the camera.

The MTF is larger than 0.28 at 40 cycles / mm in the wavelength range between 500 and 800 nm, and in the complete FOV.

Table 3.4. MTF for objects at infinity

Field	MTF	
	RAD	TAN
0°	0.57	0.57
15°	0.52	0.53
20°	0.51	0.44
25°	0.47	0.28

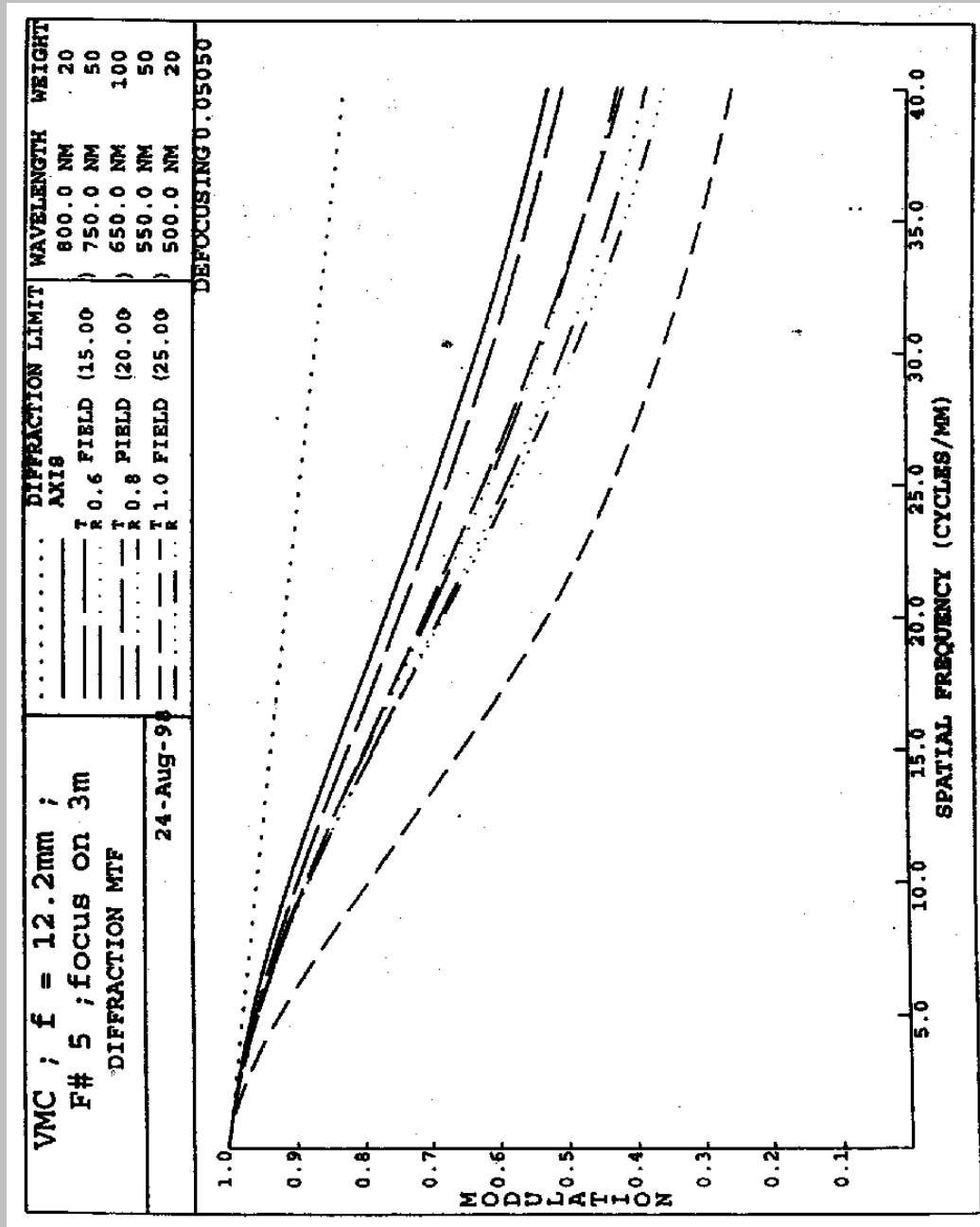

Figure 3.5

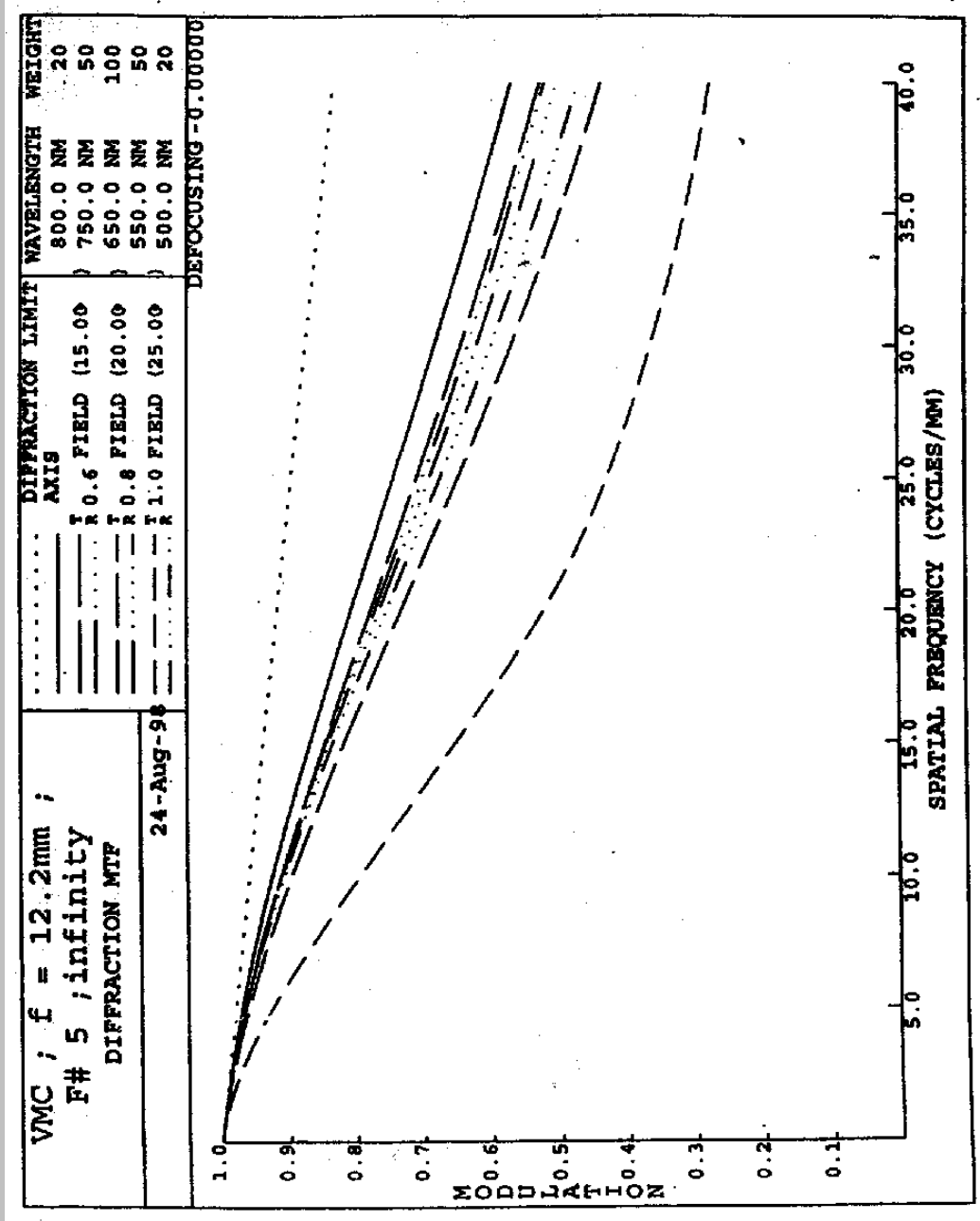

Figure 3.6

3.2.3.2 Encircled energy

The diameter of the circle that contains more than 60% of the energy is calculated.

In table 3.5 these diameters are listed at various field points. The diameter is smaller than 20 μm for all field points.

Table 3.5 : Diameter for encircled energy 60%, in the specified spectral range at different field points within the FOV of the camera.

Field	diameter (μm)
0°	11
15°	12
20°	14
25°	20

3.2.3.3 Definition of passband filter

Only in case of a black & white camera, a blocking filter is inserted with the following characteristics :

$T \geq 90\%$ average at $570\text{ nm} < \lambda < 740\text{ nm}$

$T \leq 1\%$ absolute at $350\text{ nm} < \lambda < 500\text{ nm}$ and $800\text{ nm} < \lambda < 1100\text{ nm}$

3.2.3.4 Distortion and field curvature

The distortion and the field curvature are shown in fig.3.7 for angles within the FOV of the camera.

The distortion of the camera is 0.4 % and the field curvature is smaller than 0.22 mm.

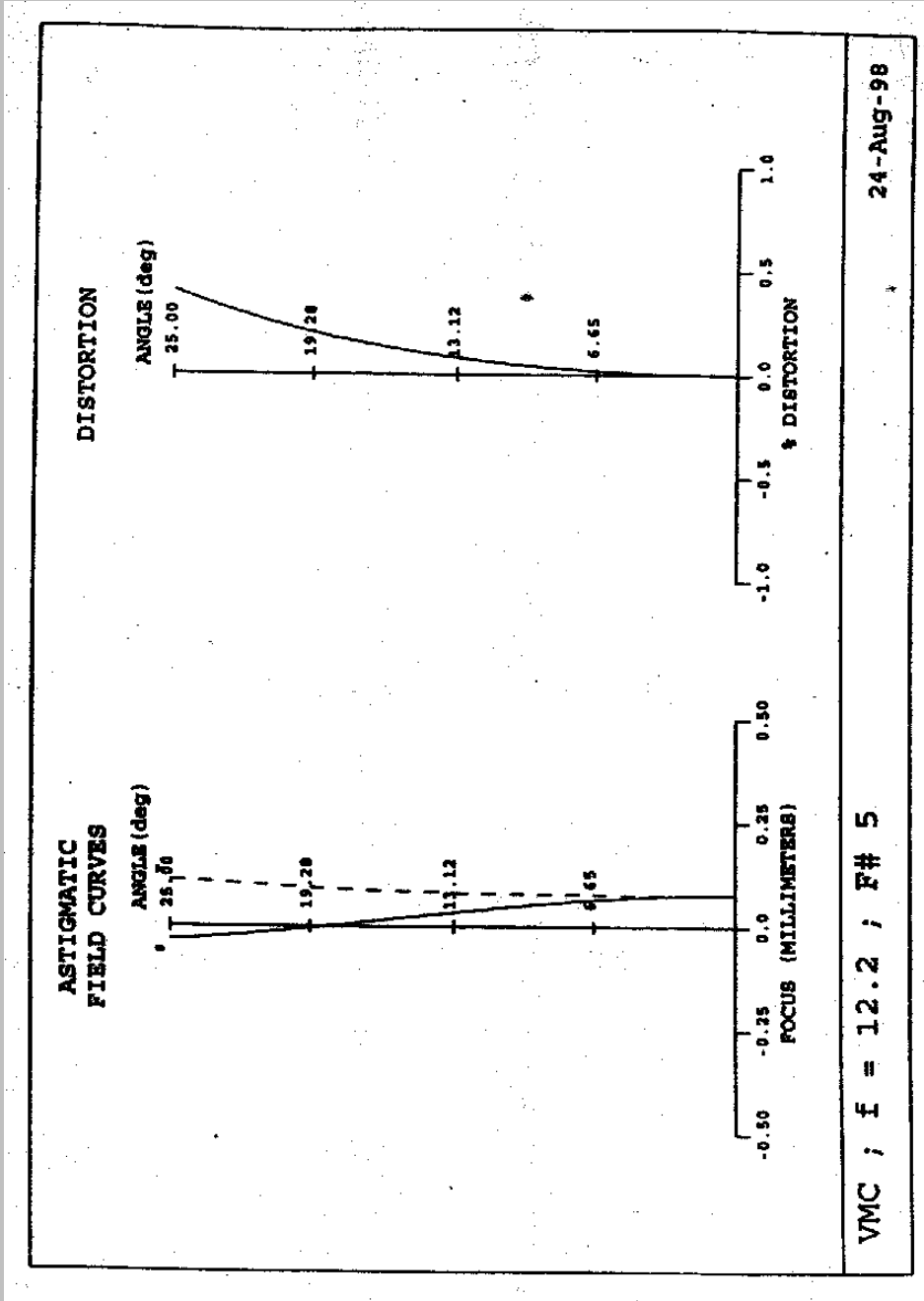

Figure 3.7

3.2.4 THERMAL ANALYSIS

The thermal analysis is performed on the system assuming that all parts have the same temperature. The analysis is based on the following assumptions:

- nominal temperature : 20°C
- nominal pressure : vacuum
- operating temperature range: -50°C to +65°C

The following materials were used (see also chapter 3.3, mechanical design description):

The material of the objective housing is Invar (expansion coefficient = $0.56 \times 10^{-6} / ^\circ\text{K}$).
The material of the detector mount is also Invar.

The thermal behaviour is analysed at -50°C, -25°C, 0°C, 20°C, 40°C, and 65° (see tables 3.6 to 3.11). The MTF and the encircled energy almost don't change in the specified temperature range.

When the tolerances are taken into account, an extra loss in MTF of 10% and an extra increase of the diameter of encircled energy of 4 μm must be taken into account.

Table 3.6 : Performance of the system at -50°C (at best focus position at 0° field angle)

Field angle	%MTF		Encircled energy (60%) (μm)
	RAD	TAN	
0°	57	57	11
15°	53	52	12
20°	52	44	14
25°	48	25	20

Table 3.7 : Performance of the system at -25°C (at best focus position at 0° field angle)

Field angle	%MTF		Encircled energy (60%) (μm)
	RAD	TAN	
0°	57	57	11
15°	52	53	12
20°	51	44	14
25°	47	25	20

Table 3.8 : Performance of the system at -0°C (at best focus position at 0° field angle)

Field angle	%MTF		Encircled energy (60%) (μm)
	RAD	TAN	
0°	57	57	11
15°	51	53	12
20°	50	44	14
25°	46	25	20

Table 3.9 : Performance of the system at 20°C (at best focus position at 0° field angle)

Field angle	%MTF		Encircled energy (60%) (μm)
	RAD	TAN	
0°	57	57	11
15°	51	53	12
20°	58	44	14
25°	45	25	20

Table 3.10 : Performance of the system at 40°C (at best focus position at 0° field angle)

Field angle	%MTF		Encircled energy (60%) (μm)
	RAD	TAN	
0°	57	57	11
15°	50	53	12
20°	47	43	14
25°	44	24	21

Table 3.11 : Performance of the system at 65°C (at best focus position at 0° field angle)

Field angle	%MTF		Encircled energy (60%) (μm)
	RAD	TAN	
0°	57	57	11
15°	48	53	12
20°	45	43	14
25°	42	24	21

3.2.5 STRAYLIGHT ANALYSIS

The ghost images, caused by specular reflections on the surfaces of the optical components and on the mechanical housing, were examined .

The following assumptions were made :

- ◆ The reflection coefficient of the filters in front of the objective is 10% (reflections at bandpass filter, IR blocking filter and uncoated protection glass).
- ◆ The reflection coefficient of the AR coatings on the lens surfaces is 0.5%
- ◆ The reflection coefficient of the detector surface is 20%
- ◆ The Invar housing (blackened) has a reflection coefficient of 2%
- ◆ Angles of incidence between 0° and 50° were examined.

The main sources of ghost images are the detector surface and the filters in front of the objective (uncoated front surface and bandpass filters).

The intensity of the ghost images caused by these reflections is about a factor of 13 smaller than the image of the incoming beam for field points around the axis, and decreases to a factor of 30 for field angles larger than 5° . These ghost images coincide with the image of the incoming beam.

Reflections between the detector surface and the detector window cause a ghost image with an intensity of about 500 times smaller than the image of the incoming beam. These ghost images do not coincide with the image of the incoming beam and can be disturbing.

Reflections between the detector surface and the lenses of the objective cause a ghost image with an intensity of about 1500 times smaller than the image of the incoming beam. These ghost images are smeared out over the detector surface and do not coincide with the image of the incoming beam.

All other reflections are negligible (a factor of 4000 smaller than the incoming beam) and are smeared out over the detector surface.

Since the detector has a linear response, ghost images that are a factor 100 smaller than the incoming beam will not be visible any more.

3.2.6 TOLERANCE ANALYSIS

A tolerance analysis was performed, under the condition that the maximum allowed decrease in MTF is 15%.

In table 3.12 the most important tolerances are listed. The optical surfaces are defined in fig. 3.2.

Most critical are the decenter and space tolerances. The manufacture of the optics will be stringent but feasible.

Table 3.12. : Optical and mechanical tolerances of the VMC design

surface nr	Glass	Fringes	Thickness		wedge	tilt	decenter
			Lens	Airspace			
1	0.001/0.80%	5(5)	0.1		1'		
2		5(5)		0.1		5'	
3	0.001/0.80%	5(5)	0.01		1'		
4		5(5)		0.1		5'	
5	0.001/0.80%	20(5)	0.1		6'		0.02
6		8(4)		0.1		10'	
7	0.001/0.80%	8(2)	0.03			ref	0.02
8		4(1.5)		ref			
9	0.001/0.80%	5(2)	0.03	0.02		5'	0.02
10		5(3)			5'		
11	0.001/0.80%	20 (10)	0.1			15'	
12		20(10)		adjustable			

With these tolerances, the MTF at 20°C has been calculated and is shown in table 3.13.

In table 3.14, the diameter of encircled energy of 60% is shown. The diameter of encircled energy corresponds to about two detector pixels.

Table 3.13 : MTF at 20°C, 40 lp/mm and taking the system tolerances into account.

Field	MTF	
	RAD	TAN
0°	52	51
15°	43	34
20°	41	26
25°	32	14

Table 3.14. : Diameter of encircled energy (60%)

Field	Diameter of encircled energy (60%) (mm)
0°	12
15°	14
20°	17
25°	24

3.3 *Mechanical Design*

3.3.1 MECHANICAL DESIGN DESCRIPTION

A general view of the VMC camera is shown in fig. 3.1.

The mechanical structure of the VMC camera consists of the following parts:

- the mechanical housing of the objective lenses
- the detector assembly
- the camera housing
- the camera front and back plate
- the baffle

For the mechanical housing of the camera objective, Super Invar is used. The mechanical surfaces are dark chromium treated.

The other mechanical parts are made of Aluminium type AA 7075 - T 7351. The surfaces are treated with alodine 1200 according to MIL-C-5541C. Only the surfaces in the optical path are black anodised according to PSS-01-703-1.1.

The dimensions of the camera are the following:

width:	65 mm
height:	60 mm
depth:	108 mm

The camera mass estimation is 430 g. In this estimation the additional mass for the bracket and for the interface to the spacecraft is not included.

3.3.1.1 *The Objective Assembly*

The objective housing consists of the following parts (see fig.3.8):

- 1: lens 1
- 2: lens 2
- 3: lens 3
- 4: lens holder
- 5: spacer
- 6: Vitton o-ring
- 7: retaining ring

The position alignment of the components is assured by mechanical tolerances on the mechanical parts.

The objective lenses 2 and 3 are glued in lens holder 4 with glue type EC 22/6B/A. Lens 1 is mounted in the lens holder by means of a retainer.

The mechanical stresses originating from differences in thermal expansion between the objective housing and the optical glass is reduced in the axial direction by means of a Vitton O-ring. Care must be taken that the clamping force is sufficient to withstand vibration loads.

To avoid stresses in the radial direction, an air gap between the lens edges and the holder is provided.

To reduce scattering, the mechanical parts are black anodised or dark Chromium treated.

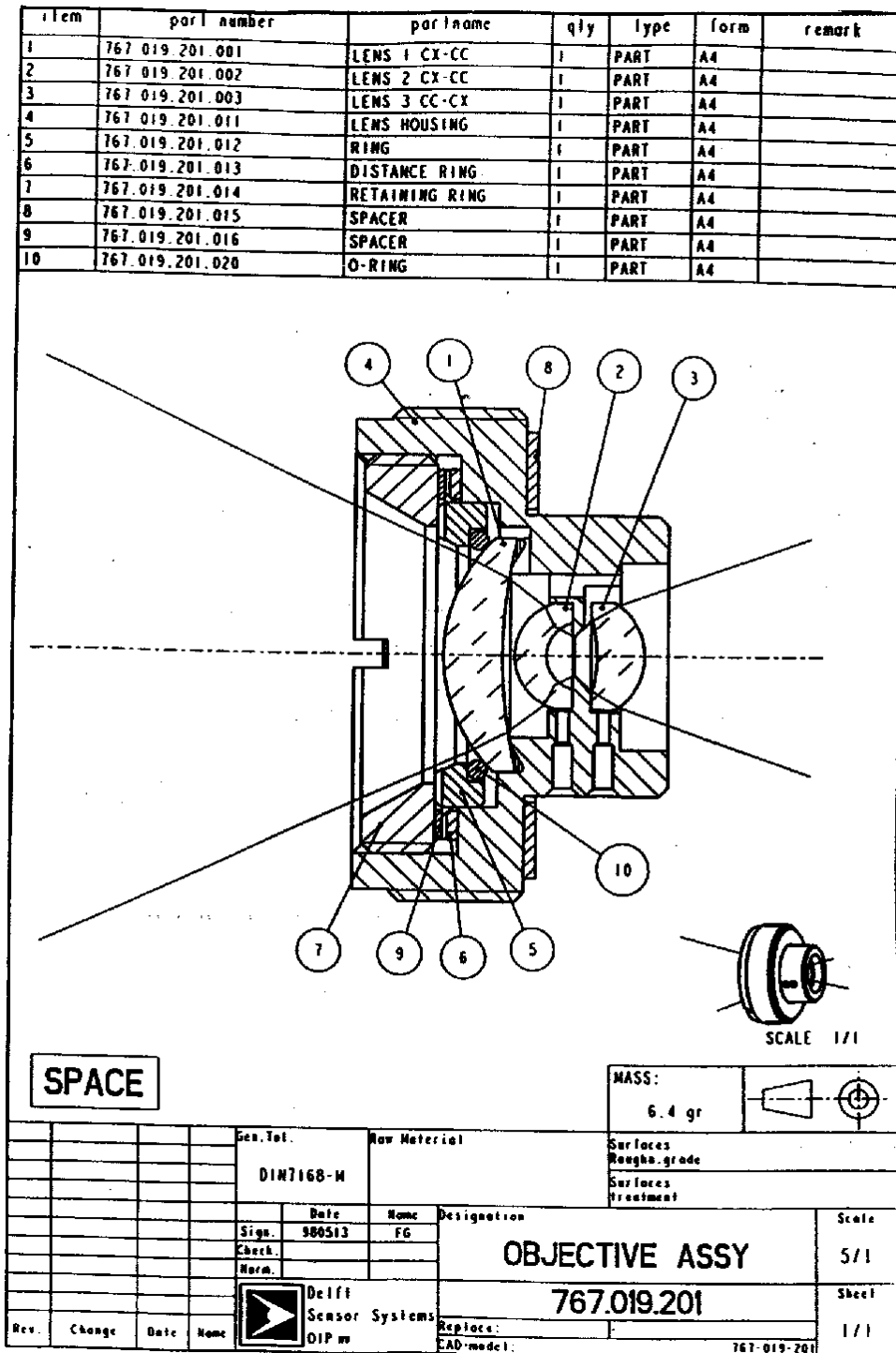

Figure 3.8

3.3.1.2 *The Detector Assembly*

The detector assembly consists of the following parts (fig. 3.9):

- 1: detector
- 2: detector window and fixture
- 3: window and detector holder

The detector window is glued on its holder (3) with glue type RTV 3145.

The detector, mounted on its ceramic structure, is glued on the mechanical holder 3 (glue type EC 2216). Care will be taken that the detector is centred with respect to holder 3, making use of reference marks applied at the detector housing.

The angular position of the detector is controlled within 1° with respect to the camera housing.

After assembly, the detector is soldered to the front PCB.

item	part number	part name	qty	type	form	remark
1		IRIS SENSOR	1	PART		IMEC
2	767.019.301.001	WINDOW	1	PART	A4	
3	767.019.301.011	WINDOW HOLDER	1	PART	A4	
4	84 PIN "J" LEAD C/C	SENSOR HOLDER	1	PART		IMEC

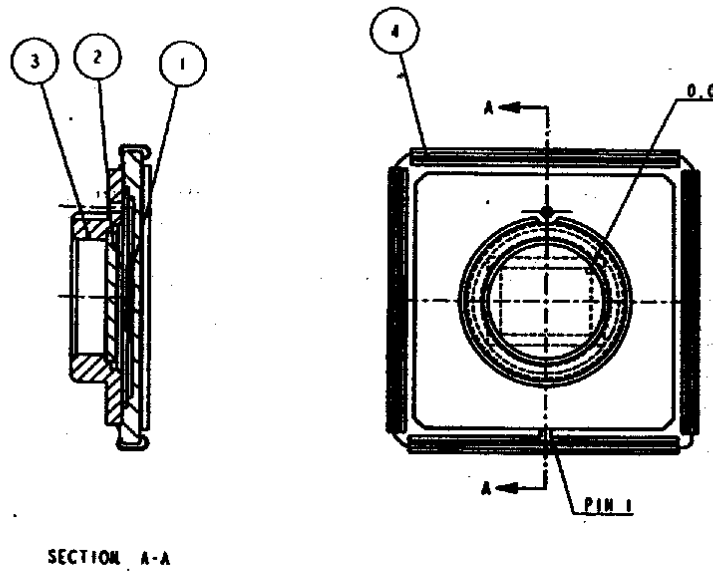

SECTION A-A

SPACE

MASS: 5.9 gr

Gen. Tol.		Rev Material		Surfaces Rough grade	
DIN7168-M				Surfaces treatment	
Sign.	Date	Name	Designation	Scale	
Check.	980519	FG	IRIS SENSOR ASSY	2/1	
Norm.				767.019.301	Sheet
Rev	Change	Date	Name		Replace:
			Dell Sensor Systems		
			OIP av		
			CAD-model:		767-019-301

Figure 3.9

3.3.1.3 The Camera Assembly

The camera assembly consists of (see fig. 3.1):

- 1: the VMC premount
- 2: a back plate
- 3: the housing

- ◆ The VMC premount (fig. 3.10) consists of a front plate on which the camera objective and the electronics unit are mounted.

The 5 PCBs are interconnected by means of flexible connections, and are mounted on the camera frontplate by means of spacers and screws.

The objective is mounted to the frontplate by means of an adapter provided with screw thread. This adapter allows the integration of different detectors and objectives.

In between the camera objective and the adapter, a spacer allows a proper focusing of the camera objective on the detector surface.

- ◆ The back plate that contains the 25 pins and the 9 pins Sub-D connectors (fig. 3.11) is mounted with 4 screws, type M3x16AISI 304, to the back side of the PCB stack.
- ◆ After mounting the backplate to the PCB stack, the camera housing is clamped between the front and the back plate.

The camera is provided with 8 helicoils M4x1.5d in front and backplate for interface with the bracket (see fig. 3.11).

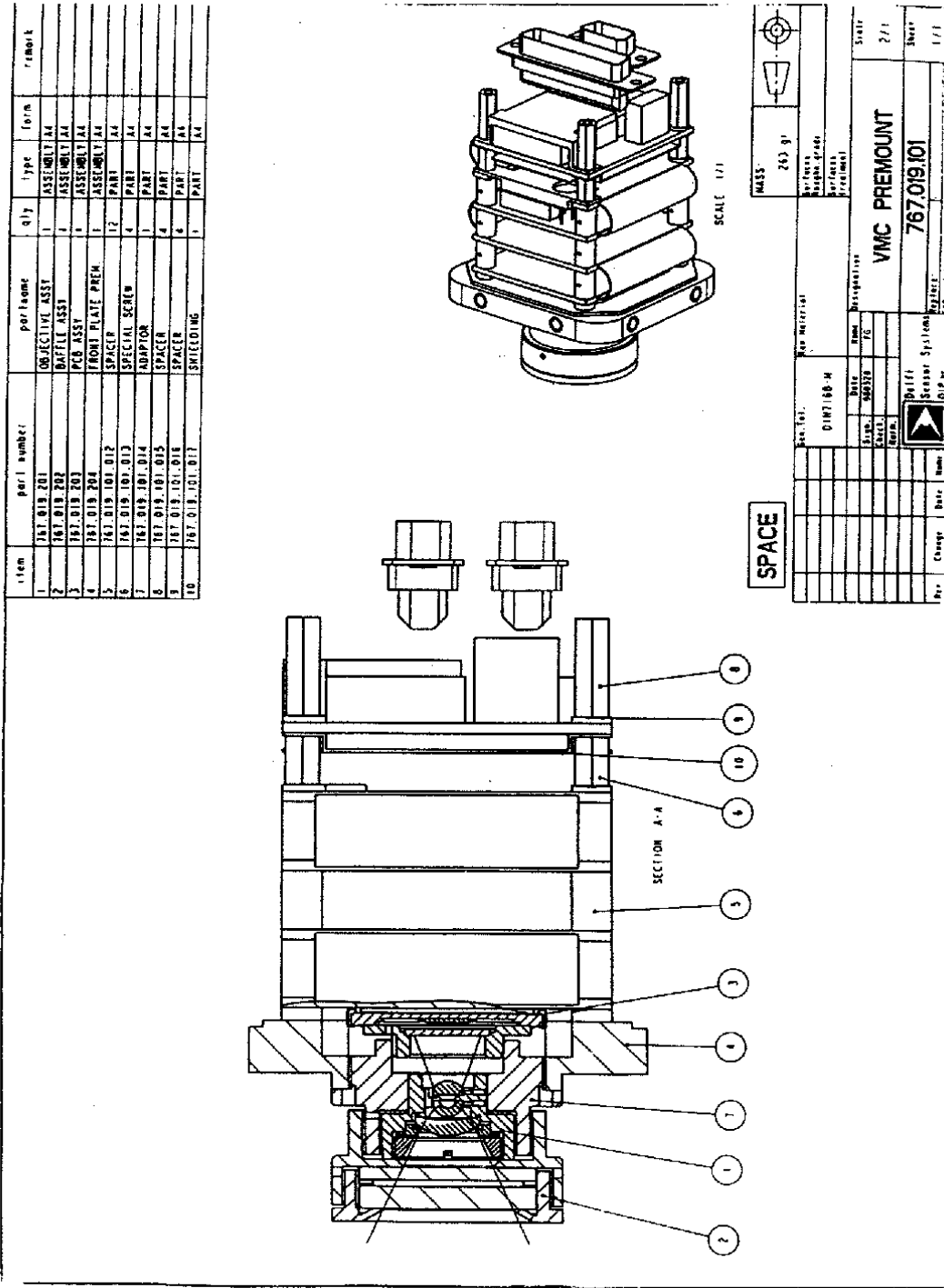

Figure 3.10

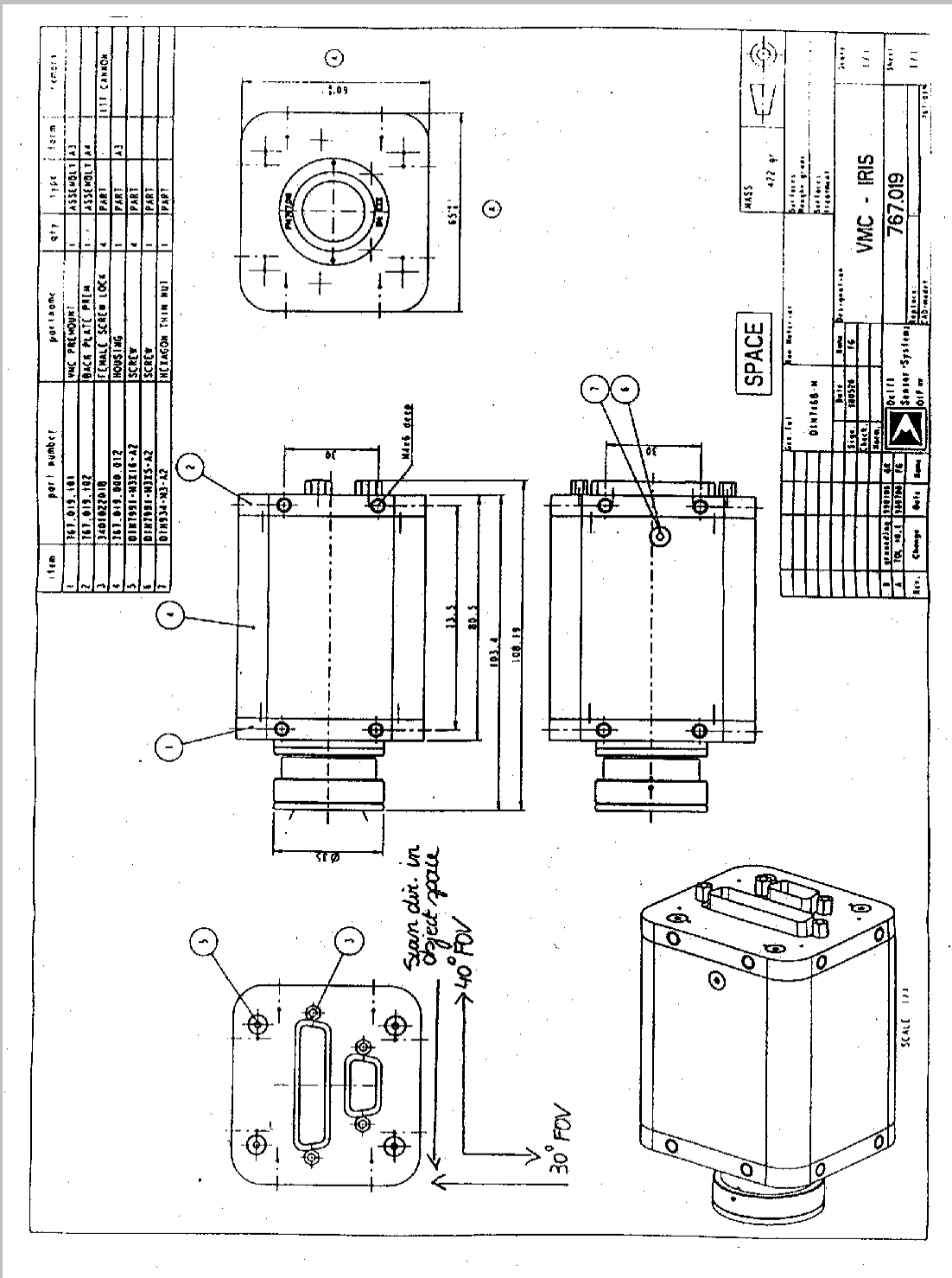

Figure 3.11

3.3.1.4 The Baffle

To prevent straylight to enter the camera objective, a baffle is mounted on the objective (fig. 3.12). The baffle contains the IR blocking filter.

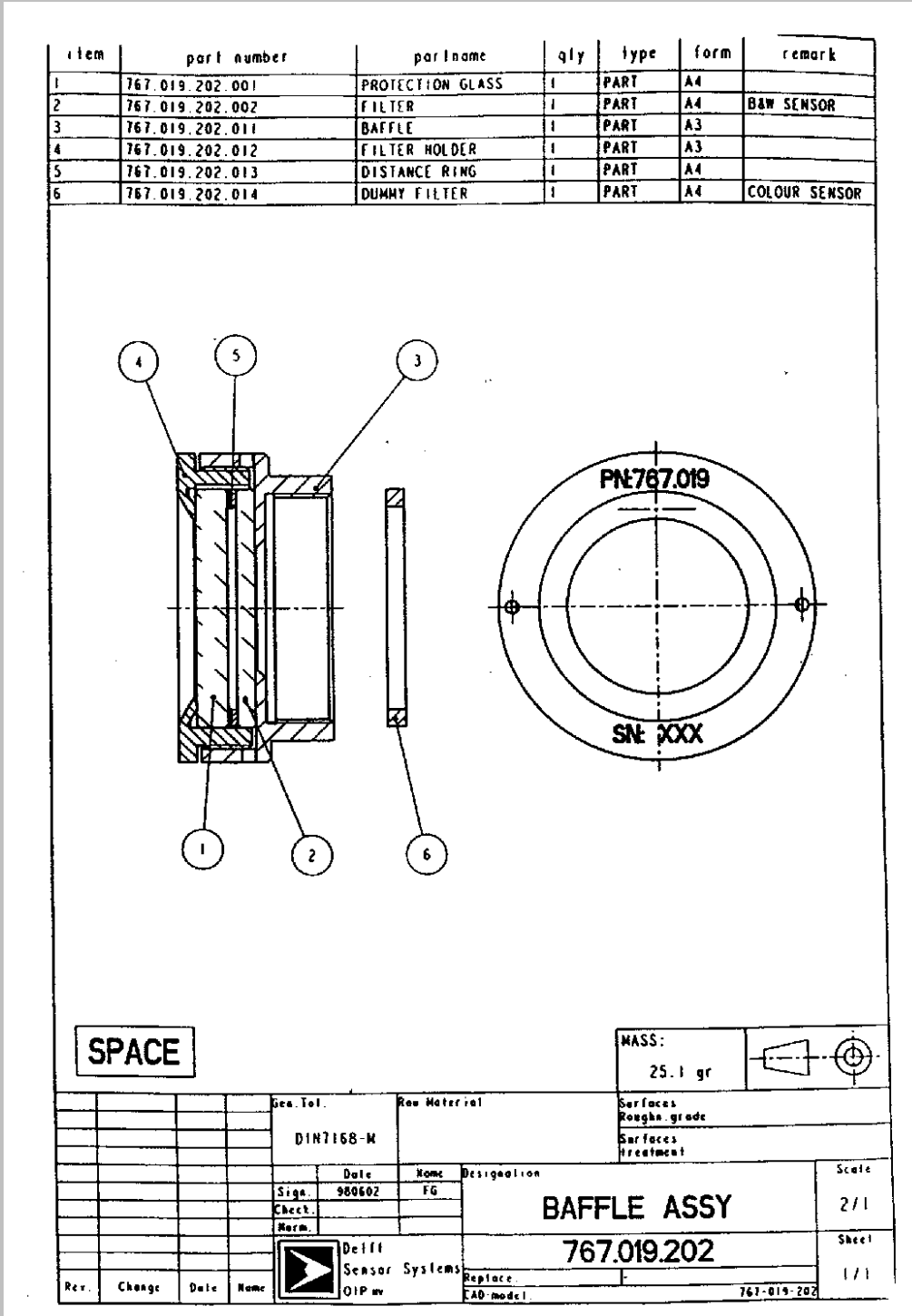

Figure 3.12

3.4 *Electrical Design For IRIS VMC*

3.4.1 CAMERA MODULE OVERVIEW

The Visual Monitoring Camera (VMC) is a stand-alone digital camera featuring a choice of sensors which can give a colour or greyscale images. It accepts image capture and exposure control commands, performs image acquisition, and stores one image in a local memory buffer to facilitate readout at a low data rate. It accepts commands from, and transmits image data to, a standard serial digital interface. An overview of the general VMC electrical characteristics are given in Table 3.15.

3.4.2 CONVENTIONS

Bit vector objects are denoted as "NAME[0..N]". Here "NAME[0]" is the most significant bit.

Binary literals are denoted between double quotes, e.g. "0010", where the leftmost bit is the most significant bit.

The ampersand ('&') is used as a concatenation symbol for binary objects and literals, e.g. "01"&"111" equals "01111".

Logic signals with inverse polarity ('active low') are denoted as "SIGNAL\" or "SIGNALb".

The term "(image) acquisition" is used to denote the actual photo-electric process of image gathering on the sensor, possibly including an internal transfer of data from the sensor to memory.

The terms "(image) readout" and "download" are used to denote a transfer of data from internal memory to the end user or space craft.

The term "atomic" describes an operation that cannot be aborted; the term "non-atomic" describes an operation that can be aborted.

Image Sensor Type	IRIS
Sensor characteristics	IMEC IRIS-1 integrating CMOS APS. 640 x 480 pixels, linear response. Colour: optional Bayer pattern colour mosaic on-chip. Requires interactive control of exposure time.
Pixel pitch	14µm
Resolution	2 pixels
Electronic shutter	Yes
Blooming	Local
SNR	65dB
Optical dynamic range	2 decades linear
<u>General</u>	
ADC	8 bit flash, 7 bits effective resolution
Image capture speed	200ms or slower
Image read modes	Full images
Local image buffer	One full image, SRAM-based
Interface	Synchronous serial, TTC-B-01 compatible ([RD4] ML16 version)
Power input	28Vdc
Power consumption	<3W (average), 5W (short-term peak, <200ms duration)

Table 3.15 General VMC Electrical Characteristics

3.4.3 ELECTRICAL INTERFACES

3.4.3.1 Power supply

The VMC internally converts a 28Vdc, <235mA supply voltage down to 12Vdc with a 550kHz switching DC/DC converter. After this, the 12V is regulated down to 5V using linear converters.

3.4.3.1.1 Power interface

connector type: DSUB-9, male, mounted on VMC backplate.

pin	signal name	signal type	signal function
1	SHIELD	-	primary power line shield
2	NC	-	-
3	P_RTN1	.RTN1	primary power return line
4	P_V1	.SUP1	primary power input, 28V DC, 235mA max.
5	SHIELD	-	primary power line shield, 2
6	NC	-	-
7	P_RTN2	.RTN2	primary power return line, 2
8	P_V2	.SUP2	primary power input 2
9	NC	-	-

Tabel 3.16

The S/C PP 28Vdc has to be applied between P_V1/2 and P_RTN1/2. P_V1/2 draws up to 235mA during operation of the VMC. P_V1/2 draws <4mA when the power converter is inhibited (see section 3.4.3.1.2).

The power interface fully isolates the incoming primary supply from the camera system downstream of it.

3.4.3.1.2 Power converter shutdown, INHIBIT_b function

The DC/DC voltage converter can be enabled and disabled under control of an external logic signal, named the INHIBIT_b signal. This 2-wire signal resides at the data connector pins named TRIG_P and TRIG_N.

If the TRIG_P/TRIG_N pins are connected to the power supply INHIBITb port, then by shorting the pins TRIG_P and TRIG_N, where TRIG_N always is at the potential of ground P_RTN1/2, with a resistance less than 10Ω and capable of passing 4mA, the switching voltage regulator is switched off, and the camera is made inoperational. This while the primary 28V supply voltage is still applied.

When then the connection between pins TRIG_P and TRIG_N is made open, the DC/DC converter powers on and the VMC comes to action. Note that with the TRIG pins open, up to 11V can appear on pin TRIG_P.

EMC filtering: TRIG_P is shunted to TRIG_N with a 10nF or 100nF capacitor. The cable used between both pins should be a shielded twisted pair.

3.4.3.1.3 Power supply block diagram

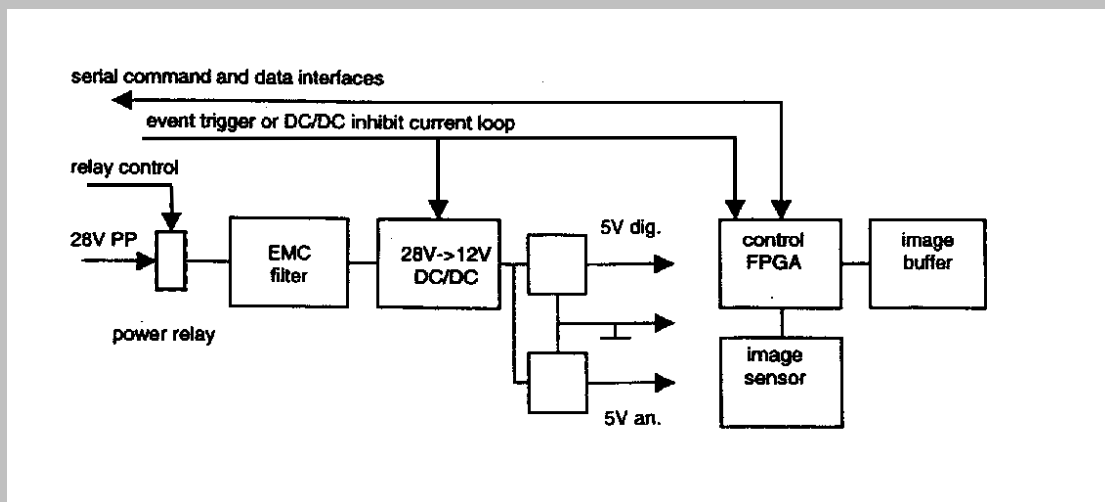

Figure 3.13

3.4.3.1.4 Power relay control

The VMC for MEX is equipped with a power isolation relay (see configuration). This relay makes or breaks the contact between the primary power source and the VMC. The relay control signals are as follows:

- A positive pulse between ON_P and ON_N (see command/data interface connector) switches the VMC on. The pulse is to be 12V, 13ms long.
- A positive pulse between OFF_P and OFF_N (see command/data interface connector) switches the VMC off. The pulse is to be 12V, 13ms long.

3.4.3.2 Data Interface

3.4.3.2.1 Synchronous serial command input

3.4.3.2.1.1 General description

The synchronous serial command input employs three signals and is fully compatible with the TTC-B-01 ML16 variant as described in [RD4], page 30.

3.4.3.2.1.2 Interface signals

Signal name direction

MLS_P	in	Word valid sample signal, active low
MLS_N	in	MLS complement
TFC_P	in	Bit transfer clock
TFC_N	in	TFC complement
MLD_P	in	Command data, 16 bits serial
MLD_N	in	MLD complement

3.4.3.2.1.3 Timing diagram

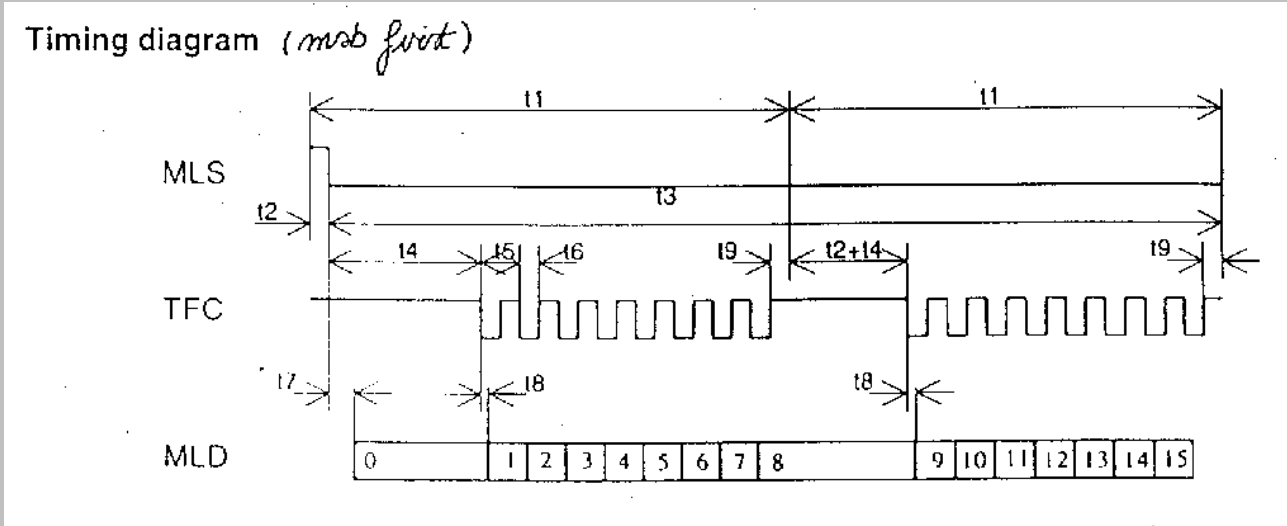

t_1 -

t_2 >960ns

t_3 -

t_4 >960ns

t_5 >960ns

t_6 $t_5/2$

t_7 > 480ns

t_8 >160ns

t_9 >0ns

maximum bit rate 1MHz (250 k Hz on the Reference VMC)

minimum bit rate 1kHz

Note : on the Reference VMC (with TTC interface), maximum input bit rate is limited to 250 kHz ; above timings should then be scaled times 4.

3.4.3.2.1.4 Electrical standard

Logic level	Electrical signal level
-------------	-------------------------

0	$MLD_P < MLD_N; 0 < MLD_P, MLD_N < 5V$
---	--

1	$MLD_P > MLD_N; 0 < MLD_P, MLD_N < 5V$
---	--

3.4.3.2.1.5 Data rates

The interface is self-synchronising. The allowed input data rates span a range of 1kHz up to 1MHz.

3.4.3.2.1.6 Interface operation

See [RD4], page 30.

The input interface features a time-out which comes into play when any initiated command transfer stalls mid-word and is not resumed within a time of 1 millisecond.

3.4.3.2.2 Synchronous serial data output**3.4.3.2.2.1 Interface signals**

Signal name	direction	
SDS_P	in	Word valid sample signal SDS
SDS_N	in	SDS complement
TFC_P	in	Bit transfer clock TFC (also in 3.4.3.2.1))
TFC_N	in	TFC complement
SDD_P	out	Telemetry data SDD, 16 bits
SDD_N	out	SDD complement

3.4.3.2.2.2 Timing diagram

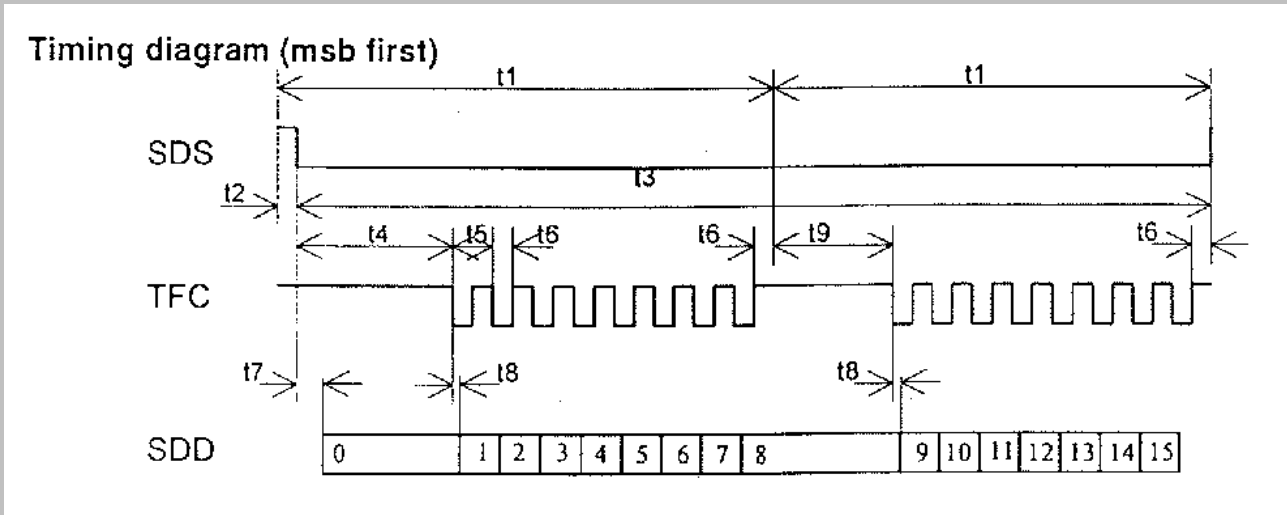

t_1	-
t_2	>960ns
t_3	-
t_4	>960ns
t_5	>960ns
t_6	$t_5/2$
t_7	0ns
t_8	640ns
t_9	> 0ns

3.4.3.2.2.3 Electrical standard

Logic level	Electrical signal level
0	$SDD_P < SDD_N; 0 < SDD_P, SDD_N < 5V$
1	$SDD_P > SDD_N; 0 < SDD_P, SDD_N < 5V$

3.4.3.2.2.4 Data rates

The interface is self-synchronising to the externally applied bit transmit clock TFC. The allowed TFC input clock rate spans a range of DC up to 1MHz, with a nominal duty cycle of 50%.

3.4.3.2.2.5 Interface operation

See [RD4], page 51.

3.4.3.2.3 Synchronous interface compliance with [RD4]

All TTC-B-01 interface circuitry is according to [RD4], sections 3.3.2 and 3.3.7.

Note that the TM/TC interfaces are without packet formatting and without TM block formatting.

The asynchronous interfaces use the same electrical circuits and are hence not strictly compliant with e.g. the RS-422 and RS-485 standards.

3.4.3.2.4 On-board thermistor

The VMC features an on-board thermistor, of which both floating terminals, THER_P and THER_N, can be accessed on the command/data interface connector. The thermistor is internally thermally coupled to the VMC's circuit boards.

Part type YSI-44031 (commercial equivalent of NASA YSI-44908)

Resistance 10k at 25°C (zero-power)

Power rating 1mW max. at 125°C

Time constant 25s (max.)

EMC filtering: 1 nF to 100nF is present in shunt with the thermistor.

3.4.3.2.5 *Command/data interface connector specification*

Connector type: DSUB-25, male, mounted on VMC backplate.

Pin	pin name	pin type	pin function
1	SDS_P	.TRUE	SDS positive phase
2	SDS_N	.COMP	SDS negative phase
3	SDD_SH	-	SDD shield
4	THER_P	.SIG	thermistor positive connection
5	THER_N	.RTN	thermistor negative connection
6	ON_P	.SIG	camera ON relay positive phase
7	ON_N	.RTN	camera ON relay return
8	OFF_SH	-	camera OFF shield
9	MLD_P	.TRUE	MLD positive phase
10	MLD_N	.COMP	MLD negative phase
11	MLS_SH	-	MLS shield
12	TFC_P	.TRUE	TFC positive phase
13	TFC_N	.COMP	TFC negative phase
14	SDS_SH	-	SDS shield
15	SDD_P	.TRUE	SDD positive phase
16	SDD_N	.COMP	SDD negative phase
17	TRIG_P	.SIG	power supply INHIBITb signal phase
18	TRIG_N	.RTN	INHIBITb return phase, connected to P_RTN1/2
19	ON_SH	-	camera ON shield
20	OFF_P	.SIG	camera OFF relay positive line
21	OFF_N	.RTN	camera OFF relay return
22	MLD_SH	-	MLD shield
23	MLS_P	.TRUE	MLS positive phase
24	MLS_N	.COMP	MLS negative phase
25	TFC_SH	-	TFC shield

Table 3.17

3.4.3.2.6 Command/data interface electrical circuit descriptions

The command and data interfaces comply to a specific flavour of TTC-B-01, described in [RD4], section 8.

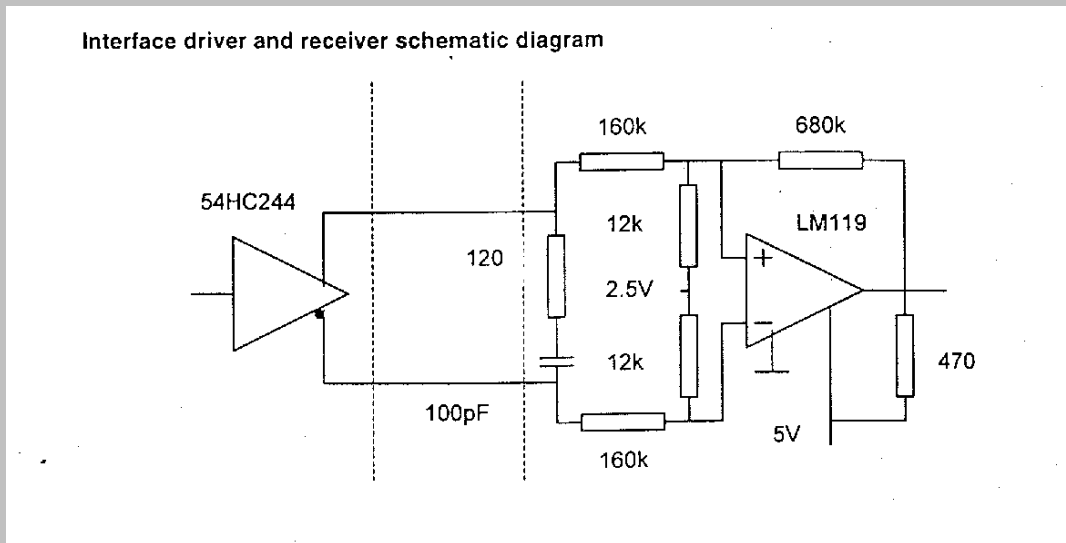

Figure 3.14

3.4.3.2.6.1 Output signals

Output signals emerge in complementary 0/5V format through standard CMOS 54HC244 buffers.

3.4.3.2.6.2 Input signals

Complementary 0/5V format input signals are converted to a single-ended format using an LM-119 comparator, fed from 5V dc and with a mid-point bias at 2.5V.

Input lines are (ac) terminated with 120 Ohms.

See [RD4] and Appendix II for full circuit details.

3.5 *EMC and PP Interface Compliance*

The S/C PP is interfaced to the VMC by a power isolation relay, an Interpoint FMSA-461 EMC filter and a dc isolating Interpoint MSA-2812S switching DC/DC converter, in that order. See the schematic in Appendix II, sheet 5/5, for details.

3.5.1 PRIMARY POWER SUPPLY INTERFACE, ELECTRICAL ISSUES

Over/under voltage tolerance: the VMC power supply interface complies with MIL-STD-704-A-D and tolerates short-term (50ms) supply line excursions on PP in the range 0 to 80V. The longterm tolerated input voltage during on-time is 16 to 40V. PP input voltage reversal is not tolerated.

The VMC's 28Vdc PP interface provides for electrical isolation between PP and Secondary Power, and between PP and VMC housing.

VMC power supply turn-on typically lasts <25ms and causes overshoot of <5V on the PP supply line, and <150mV on the SP line.

3.5.2 CONDUCTED EMISSIONS ON PRIMARY POWER, FREQUENCY DOMAIN

The sole interface between S/C PP and the VMC consists of an Interpoint FMSA-461 line filter, followed by an (isolating) Interpoint MSA-2812S switching DC/CD convertor.

This combination reduces reflected ripple current on the primary power line to within US MIL-STD-461 C, Method CE03 tolerances.

3.5.3 CE ON SIGNAL LINES

Data and command interface lines: interface circuitry is according to [RD4], sections 3.3.2 and 3.3.7.

Inhibitb/trigger interface: a 10nF to 100nF shunt capacitor filters the line.

Thermistor interface: a 1 nF to 100nF shunt capacitor filters the line.

The VMC is a fully-closed non-hermetically sealed metal box, grounded at the S/C structure.

3.5.4 RADIATED INTERFERENCE

To be tested post-design. The VMC is a fully-closed non-hermetically sealed metal box, grounded at the S/C structure.

3.6 VMC hardware grounding layout

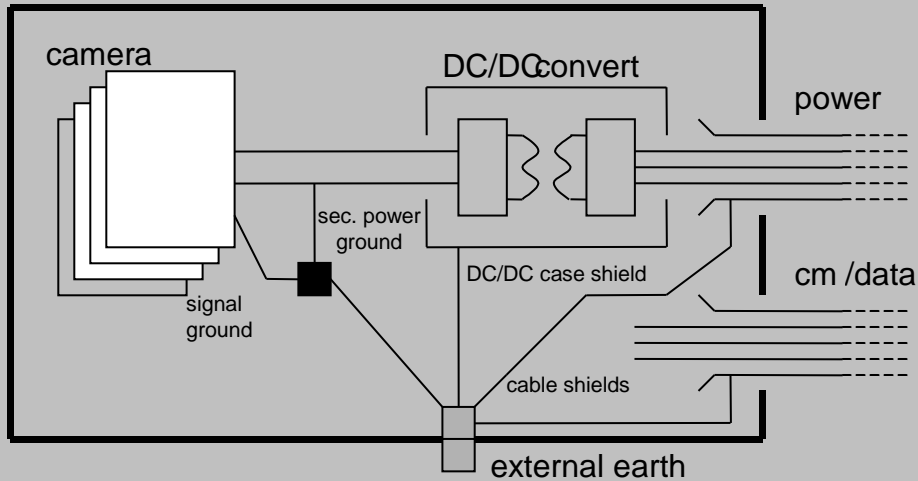

Figure 3.15

3.7 Power Consumption Profile

Power dissipated during image acquisition or during fast (>1Mbps) image download: 5.0W to 6.0 W (estimated by IMEC).

Duration : < 200 ms.

Power dissipated during idling: approx. 2.8W

Image acquisitions, regardless of the chosen integration time, last 200 ms for the power calculation.

During image downloads slower than 1Mbps, the power consumption roughly equals the power used during idling.

Power profile: usually image acquisitions are followed by slow image downloads. A channel bandwidth of 64kbs results in a download time of 38s. This gives the following cyclic power profile:

Operation	power	duration
Image acquisition	5.0-6.0W	200 ms
Image download	2.8W	38 s
System Idling	2.8W	-

3.8 *Sensor Specifications*

IMEC IRIS-1 integrating CMOS APS imager ([RD1])	
Resolution	640x480 pixels
Pixel size	14 μ
Fill factor	72%
Die size	10 x 8mm
Pixel type	3-transistor active pixel, integrating
Electro-optical transfer	linear
Spectral response	400-900nm
MTF	0.18
Frame rate	10Hz
Exposure control	user control required
Electrical SNR	65dB (prior to ADC)
Non-uniformity	dark: 0.15% of peak signal, after on-chip CDS; lit: PRNU 10%
On-chip ADC	8-bit flash
Access method	sequential scan
Colour	B&W and Bayer pattern-RGB available
Notes:	developed under ESA contract, chip with prototype status, requires IR-cutoff filter to minimise optical crosstalk, requires gamma correction

Table 3.18.

4 CAMERA CONFIGURATIONS VMC FOR MEX

4.1 *System configuration*

Prior to use and during assembly, the VMC has to be configured for specific operation modes. This configuration is hard-wired for each individual camera and has to be specified before construction. Once the VMC camera has been configured, it cannot be reconfigured. The actual configuration for MEX is defined in table 4.1.

CAMERA		MEX P/N 767.019 S/N 05	SPARE P/N 767.019 S/N 06
Color		YES, RGB	NO, B&W
Sensor type		IRIS 1 lin. response	IRIS 1 lin. response
pixels		640x480	640x480
Def. Exp.		14ms.	14ms.
1st image acquisition pre-defined by SNAP			
SNAP		10000	00000
TSC		147s	147s. not used
TS (delay time)		147s	0s
1st image after		150s.	3s.
Interface			
I/F type		TTC-B-01	TTC-B-01
Operational mode (AUTO 0 = command interactive mode)			
AUTO		0	0
Power Supply			
Inh. mode		YES	YES
Prim. power		28V DC	28V DC
Relay		YES	NO
Thermistor		YES	YES

Table 4.1

The following list gives an overview of the VMC settings, which are hardwired on the FPGA PCB for the IRIS S/N05 for MEX:

Name	S/N 05 setting	function
AUTO	0	selects autonomous or command-interactive operation of the camera. 0 = command interactive
EXP	100	selects default exposure time = 14 ms
SNAP, TSC	10000	selects method and delay for the acquisition of the first image. This setting will make use of a burned-in delay of TSC=147 seconds after power-on
INBD	111	selects TTC-B-01 ML16 command input interface type
OUTBD	111	selects TTC-B-01 TM16 data output interface type

4.1.1 OPERATIONAL MODE

AUTO	operation mode
0	command-interactive
1	autonomous operation after start-up

4.1.2 DEFAULT EXPOSURE TIME

The default exposure time settings for an IRIS VMC:

EXP[0..2]	Exposure time (ms)
000	0.5
001	1
010	2
011	4
100	14
101	54
110	200
111	-

4.1.3 TRIGGERED SNAPSHOT

The VMC can be made to acquire and store a first image in several ways. The trigger for the first image can be implicit, after system power-on, or explicit, via a trigger signal (see TRIG_P/TRIG_N pins on the electrical interface). The first image is taken a user-defined period TS after power-on or after the explicit TRIG event.

Pin SNAP[0] selects between a pin-configurable predefined delay and a custom delay time TSC which can be burned individually into each VMC during assembly.

SNAP[0]	source for delay time TS
0	predefined delay for triggered snapshot: TS <- SNAP[2..4]
1	burned-in delay TSC for triggered snapshot TS <- TSC

TSC is hard-programmable in a range of 0 to 255 seconds.

Pin SNAP[1] selects between a first image taken TS seconds after a trigger signal on TRIG_P/TRIG_N, or a first image taken (3+TS) seconds after power-on.

SNAP[1]	trigger event definition
1	first image taken TS seconds after TRIG_P/TRIG_N trigger signal goes high (note: trigger has to come at least 3 seconds after VMC power-on)
0	first image taken (3+TS) seconds after power-on

SNAP[2..4] configures the delay time TS:

SNAP[2..4]	TS (seconds) when SNAP[0]=0	TS when SNAP[0]=1
000	0	TSC
001	2	TSC
010	4	TSC
011	8	TSC
100	16	TSC
101	32	TSC
110	64	TSC
111	128	TSC

5 FUNCTIONAL SPECIFICATION

5.1 *Internal states, variables and default values*

The MEX-VMC holds the following variables in internal registers. The user by means of TC-commands can control these variables. The table also lists the default values for the variables after power-on or reset.

Parameter or internal setting name	allowed range of values	default value	Purpose
Exposure	integer {0,1,2,...,239}	See EXP	integration time, see 5.6.2.
Nframes	Integer {0,1,2,...,128}	128	Number of frames to acquire, 128 means infinity
Mode	bit vector[0..7]	"00000000"	Operational mode settings
SystemStatus	bit vector[0..7]	"0000001"	Read-only register, reads "00000000" when the sensor supply voltage sags, i.e. when latch-up is presumed.

5.2 *VMC start-up, system reset, initial state, sensor power monitoring*

Upon power on, the VMC performs a reset. After this reset all internal settings and parameters take on their default values (see 5.1). During reset all output signals take on their default de-asserted values. For the output interfaces, the specific default value on an output pin may depend on the specific interface the camera has been configured for.

Then interactive mode is entered after 150 seconds, the burned-in delay time for the first image to be taken after separation. In the interval between power-on and power-on + 150 seconds any incoming command is ignored.

5.3 *First image after start-up*

After VMC power-on, according to the settings of SNAP/TSC, the VMC acquires one image and stores it in memory and is ready for download.

The first image can be read any number of times from the memory by subsequent TTC-B-01 TM16 interrogation cycles.

Any incoming READ_FRAMES commands (see 5.7.1) will only be serviced after the buffer has been read entirely at least once after the acquisition of the first image.

These features of operation allow the acquisition of an image (the first one after power-on), precisely triggered by an external event. It also guarantees the successful download of each image, as it resides in the memory buffer, and can be read from it as many times as needed, until a READ_FRAMES command (to acquire a new image) is received. None of these features will not be used by MEX since the interactive mode is not possible due to the distance between the earth and the spacecraft. The commanding of the VMC must then be done in batch mode.

5.4 *Commands: format, overview, and handling*

5.4.1 COMMAND STRUCTURE

The camera is interactively controlled by user command words, issued to the command-input interface. The VMC command format is a 2-byte format which allows the ground to encapsulate these commands within standard SGICD TC(2,2) [RD 1]. The TCs to configure the VMC are included into the MTL and are transparent to the DMS S/W (routing to VMC only).

The generic structure of a command that will be used by the VMC cameras comprises the actual command identifier (6 bits) and command and argument parity bits (2 bits, making 1 octet in total), followed by one argument (8 bits or 1 octet). Commands that have no actual argument still require the transmission of a dummy argument, of which the contents are ignored by the camera. The MEX Ground Segment software will not make use of the parity bits; they will be ignored.

Command			Argument
Bits 0..5	Bit 6	Bit 7	Bits 0..7
Command type	Odd parity over Command Type. Used by VMC only	Odd Parity over Argument Used by VMC only	Argument value (bit 0 is MSB)

A command communication error occurs in the VMC when one of the command's parity bits is faulty or when an unrecognised command is received. Faulty commands are ignored and thus cannot change the state of the VMC.

New commands overrule any older command, whether that is still pending or being executed. There are two exceptions. In case the old command comprises of image acquisition, the current image being acquired is downloaded once before the new command comes into action, e.g. a change of settings (exposure, ...) only comes into action after a new READ_FRAMES command is given. The other exception is the RESET command, which always executes immediately.

5.4.2 GENERAL OPERATION: COMMANDS, COMMAND ABORTION, IMAGE DOWNLOAD

The VMC is operated by sending it commands and reading its output data. Some commands upload settings for the camera. Other commands provoke image acquisition and/or image download.

The RESET command immediately interrupts any present operation while VMC returns to the default settings (see section 3.4). As such it can be used to abort any operation at will and at any time. An example could be the abortion of an image download over a slow data channel, after the first part of the image reveals that other system parameters would lead to a better picture quality. Upload of the last used parameter settings will be necessary when different from the default settings. When a RESET command has been issued, the ground software should abort the ongoing acquisition and begin to search for the synchronisation pattern, else the next image might be lost or be concatenated with the previous one.

The " READ_FRAMES " command triggers the imaging activity in the VMC. The image is stored within the VMC buffer. This delay takes 400ms + exposure time which is in the order of 20 ms. The Flight S/W should be instructed to start interrogation of the VMC buffer data only after it is guaranteed that the 1st image is completely stored in the VMC buffer.

The TCs "Read_Frames" are included into the MTL and are transparent to the DMS S/W.

The end-user controls the readout of data by means of RTU interrogation cycles, entirely asynchronous with respect to the VMC image acquisition.

Reading the buffer consists in issuing OBDH SD16 interrogation cycles that allow reading the VMC buffer by 153,605 steps of 2-byte read cycles. The size of the data buffer to be fetched by the Flight S/W is predictable, i.e., fixed to 153,605 words = 153600 words corresponding to digitised pixels + 5 words corresponding to header and trailer. It will be hard-coded in the DMS S/W (unlike the packetised P/L's for which the DMS S/W has first to read the length of the data block to be fetched from the P/L).

In an ending sequence of images, acquired by a READ_FRAMES(N) command with $N < 128$, the lastly acquired picture always can be downloaded any number of times by using multiple OBDH SD16 interrogation cycles.

5.5 *Reset command*

command name	command format	Argument
RESET	000001	dummy

RESET interrupts all current actions and performs a complete synchronous RESET on the device. The effect of RESET is equivalent to the hardware reset performed at power-on.

It is recommended that the value of the dummy argument is equal to the command type word for RESET.

5.6 *Camera parameter setting commands*

The following procedures are used to set the various internal parameters of the camera.

5.6.1 VMC-MODE SETTING

command name	command format	argument 1
SET_MODE	100100	Mode

The SET_MODE command influences the way of image readout. It has the following word structure. Only bit 3 applies to the MEX configuration.

Bit	Name	Function	Default value
0			
1			
2			
3	Exposure Mode	VMC: 0=lines; 1=frames	0
4			
5			
6			
7			

The new settings in SET_MODE come into action after the download has been completed of any currently being acquired/transmitted frame.

When Exposure Mode is 0, the Exposure parameter (see section 3.7.2.1) denotes an exposure time based on a multiple of the imager line read time. When Exposure Mode is 1, Exposure denotes an exposure time based on a multiple of the image frame read time.

5.6.2 VMC INTERACTIVE EXPOSURE CONTROL

Command name	command format	argument
SET_EXPOSURE	100001	Exposure[0..7]

The parameters Exposure, together with the Exposure Mode setting in the Modes register (see 3.7.1), and with the current readout times of pixels and lines, and the frame dimensions (640 pixels x 480 lines for IRIS) set the integration or exposure time for the IRIS sensor.

Exposure is an integer of the range 0 to 239, a range which should never be exceeded as unpredictable behaviour of the camera may result. The relation between the value of Exposure, Exposure Mode and the sensor exposure time T_i is as follows:

$$T_i = 0.4\text{ms} * (\text{Exposure} * 2 + 1) \quad \text{when Exposure Mode} = 0$$

$$T_i = 200\text{ms} * (\text{Exposure} * 2 + 1) \quad \text{when Exposure Mode} = 1$$

Resulting exposure time is the time during which the optical sensor is exposed to light.

Image acquisition time is the time that elapses between the beginning of the exposure time and the end of the write operation from sensor to internal memory.

Exposure	Exposure Mode (in Set Mode)	Resulting exposure time (ms) (approx.)	Image acquisition time (ms)
0	0	0.4	400+0.4
1	0	1.2	400+1.2
...
239	0	200	400+200
0	1	200	200+200
1	1	600	200+600
...
239	1	95800	200+95800

Note that, at room temperature, integration times of over 10 seconds result in auto-saturation by excess dark signal. Dark signal decreases with temperature.

The VMC camera has approximately the sensitivity of an ISO-50 film. Choice of setting depends on fraction of spacecraft and launcher or Earth in view, while considering that in space the intensity is twice that on Earth on a sunny day.

5.7 *Image acquisition commands and data formats*

5.7.1 IMAGE ACQUISITION, AUTOMATIC IMAGE UPDATE, IMAGE BUFFER READOUT

command name	command format	Argument
READ_FRAMES	000010	N

READ_FRAMES reads (N+1) images. N is an integer of the range 0..128. When N = 128, an endless stream of frames is read. When $0 < N < 128$, N+1 frames are consecutively acquired and transmitted. When eventually the (N+1)th frame is acquired, stored in the buffer, and transmitted, it remains in the buffer from which it can be retrieved again with the OBDH SD16 interrogation cycle.

When N=128, i.e. endless acquisition, is selected in combination with the TTC-B-01 output interface, then images are automatically updated in the memory buffer when a new interface interrogation cycle does not start within one second of the last image acquisition.

Issuing a new READ_FRAMES while a frame already is being read, i.e. with a previous READ_FRAMES still active, interrupts the old command. The frame currently being read is then finished and entirely output, after which the new READ_FRAMES command comes into action. Every acquired and buffered frame has to be read at least once before a new READ_FRAMES command is serviced: the acquisition and subsequent download of an image requested by a READ_FRAMES command is to be considered one atomic operation.

5.7.2 IMAGE OUTPUT DATA FORMAT

An image is output as follows:

- a 32-bit synchronization pattern is followed by a 8-bit image identifier (a cyclic ascending sequence count, unique for each image acquired, not for each image downloaded, as the same image can be downloaded many times) and a SystemStatus octet holding the alarm for sensor latch-up.

After this preamble the actual image is output as a stream of PixelValues. This stream begins with the first pixel of the frame or line (the pixel in the top-left corner of the frame), and ends with the last pixel of the frame or line (the pixel in the bottom-right corner of the frame). N values are output if the frame or line contains N pixels. Two consecutive pixels, being 8 bit words each, are packed into one 16 bit telemetry word. The most significant byte of the TM word contains the first pixel, the least significant byte contains the second pixel. Finally, the transmission is ended with a 32-bit end marker.

Idle pattern

In case the TTC interface is used and no image data are available when the RTU interrogates the camera, an idle pattern is output. This particular case happens when

- the camera has not yet acquired and buffered an image, e.g. after power-on, or
- the camera sensor is in progress of acquiring a new image.

The idle pattern is 0x55 0xAA (e.g. 55 AA 55 AA 55 AA...)

No download abortion

Stalling of the RTU interrogation during an image download does not abort the download: it is resumed as soon as the RTU starts interrogating again. To explicitly provoke a download abort, the end-user has to employ the RESET telecommand.

5.8 *Transmission of the VMC data to the Ground Processing Unit.*

The telemetry consists of a continuous stream of raw images. Each image is sent line by line and every pixel is contained in 8 bits. In order to comply to TTC-B format (16 bits serial data), 2 pixels are grouped in one 16 bits word, the most significant byte containing the first pixel. Each image is preceded by a synch and start of image marker and followed by an end marker.

6 OPERATIONS PROCEDURES

6.1 *VMC Operations Timeline on Mars Express*

After each power-on the VMC camera will take 3 seconds to wakeup and waits TSC (=147) seconds delay time for the first image acquisition.

For the image acquisition, it will take 400 ms plus the strap-programmed exposure time (= 400+14ms) before the first picture is available in the VMC buffer.

This picture is ready to be downloaded to the mass-memory using a data rate of approximately 80 kbps (=62.5% of 131 kbps). The amount of image data to be downloaded is 153600 words of 16 bits, including header it will be 153605 words of 16 bits.

Complete download of the picture is reached after exactly 153605 read cycles. This lasts for approximately 38 seconds, depending on the traffic on the OBDH bus and assuming that the VMC is the unique P/L "On & Active" during the operations herein in question. Following a complete download of the picture, the VMC will be reset and a delay of 2ms is taken before the VMC can be commanded to take the next picture using a newly command-programmed exposure time.

The next picture can be downloaded after 400ms plus the command-programmed exposure time, again at a rate of approximately 80 kbps.

6.1.1 TASK SHARING BETWEEN GROUND & DMS S/W

VMC & Other Payloads

Other payloads are not foreseen to be polled together with the VMC. This allows to establish two exclusive OBDH profiles for the two intended P/L uses :

- nominal OBDH profile (Rosetta SIRS RO-DSS-IS-1001, §3.7) featuring 25% max. of bandwidth for Packet TC Users and 62.5% for TM-Block Acquisitions.
- VMC-specific OBDH profile which allocates the P/L TM bandwidth (62.5%) to the VMC buffer read. The nominal 25 % free for passing TCs to packet users is left unchanged.
 - **Ground** disables polling of all (packetised) payloads by successive TC(16,2).
 - The activation of the VMC-specific OBDH profile is implicit when the TC(130, 80) "Read_VMC_Image" is received and executed by the **DMS S/W**.

First Image

- **Ground** switches on the VMC and interface to OBDH.
- **Ground** sends TC(130,80) for the read-out of the VMC's 1st image (default settings).

Subsequent VMC Configuration Settings, Imaging, & Buffer Read Request

- **Ground** (or **Master Time Line** stored into on-board SSMM) issues TC(2,2)(Memory Load Commands) to configure the VMC (e.g., exposure time). DMS S/W just routes the TC.
- **Ground** (or **MTL**) issues TC(2,2) (MLC) to pass "READ_FRAMES" command to the VMC. DMS S/W just routes the TC.
- **Ground** (or **MTL**) issues TC(130,80) to DMS S/W : "READ_VMC_IMAGE". This TC is interpreted by the DMS S/W as the go-ahead for acquiring the VMC buffer data. Proper timing of the successive operations has to be ensured by the ground programming taking into account the delays inherent to the camera. This is detailed in the next section

VMC Buffer Read, Storage into SSMM, & Downlinking

- In response to the TC(130,80), the **DMS S/W** performs 153,605 SD16 reads (exactly counted by the DMS S/W) to download the VMC buffer data and to store it into the Mars Express mass memory (SSMM). This will take about 38 seconds (4,096 VMC OBDH interrogations/s) given the VMC is the only P/L polled at that time.
- The **DMS S/W** stores the VMC buffer data as a series of TM packets of 4,112 bytes (of which 4,096 bytes of VMC data) through TC(162,14) "Write Packet from DMS PM".
 - It starts building the VMC TM packets in a real-time manner at a rate of two 4,112-byte TM packets/second (consistent with the 4,096 VMC OBDH interrogations/s above).
 - It stores the built TM packets into the SSMM using TC(162,14) at the same rate.
 - The last TM packet will include the residual data left after the generation of the 75 preceding TM packets containing 4,096 of VMC data. The length of the packet data field is provided by the packet header.
 - The VMC packets will be downlinked through the TFG after ground request to the DMS S/W (TC).
- The DMS S/W can acquire a new image from the VMC every 42 seconds, taking into account the "buffer read" and the storage of TM packets into the SSMM (see figure 6.1).

- **Ground** (or on-board **MTL**) issues as many TC(130,80) as necessary to the DMS S/W to read subsequent images in case the "READ_FRAMES" command previously required the VMC to acquire several images.
- The ground (or **MTL**) manages the delays between the successive TC(130,80) with 1 second resolution taking into account the time to fill in the buffer with a new image (VMC-dependent), and the time taken by the DMS S/W to read the buffer and store the TM packets into the SSMM(42s).

Re-Enabling Polling of other Payloads

- **Ground** (or on-board **MTL**) re-enables the standard P/L Polling Sequence as necessary.

6.1.2 TYPICAL OPERATIONS SCENARIO

The synchronisation of the VMC operations with the Beagle-2 separation time can be handled through the MTL since the MTL TCs are time-stamped against the on-board time (SCET). A timeline diagram is presented in figure 6.1 as an example.

The delays are implemented by programming and timely execution of TCs included into the MTL pre-loaded by the Ground. The TCs (130,80) "Acquire VMC Buffer" (triggering the VMC Buffer reads) are included in the MTL at appropriate times. They are executed by the DMS S/W.

6.1.2.1 System Validation Tests activities

Objective: last checkout of the VMC and of the VMC imaging sequence for Beagle2 ejection

Date/time: during SVT sessions, proper time to be decided by ESOC

Duration: 30 minutes minimum, up to 1 hour

The SVT checkout of the VMC must be functionally as close as possible from the critical Beagle2 separation procedures. The number of images to be acquired is still to be confirmed but 10 seems to be a minimum and 20 is a reasonable value that enables to test the impact of VMC operations on SSMM performance and TM link.

The attitude of the Mars Express spacecraft with respect to the Sun will NOT be made similar to the ejection attitude. Therefore, the exposure settings for the 20 images will cover both deep space and test room conditions to maximise the return of experience from the SVT sessions.

The Beagle2 separation image sequence will contain at least 10 pictures that require 34 steps of the following procedure. But the possibility to get more images should be kept. ESOC/operations will make the final decision during Earth Verification or Interplanetary Cruise phases. The following sequence enables the acquisition and download to ground of 20 images with different exposure times. So the steps 1 to 32 and 63 to 64 are compulsory while the execution of the steps 33 to 62 depends on the total number of images allowed.

- 1- ground (or MTL) switches on the VMC and interface to the OBDH.
- 2- after 150 s from 1, ground (or MTL) sends TC(130,80) for the read-out of the VMC's 1st image (default settings).
- 3- after 42 s from 2, ground (or MTL) sends TC(2,2) for the configuration of VMC (exposure_time_01).
- 4- ground (or MTL) sends TC(2,2) for the acquisition of 1 image ("Read_Frames (1)").
- 5- ground (or MTL) sends TC(130,80) for the read-out of the new VMC image (picture_01) into the SSMM.
- 6- after 42 s from 5, ground (or MTL) sends TC(2,2) for the configuration of VMC (exposure_time_02).
- 7- ground (or MTL) sends TC(2,2) for the acquisition of 1 image ("Read_Frames (1)").
- 8- ground (or MTL) sends TC(130,80) for the read-out of the new VMC image (picture_02) into the SSMM.
- 9- after 42 s from 8, ground (or MTL) sends TC(2,2) for the configuration of VMC (exposure_time_03).
- 10- ground (or MTL) sends TC(2,2) for the acquisition of 1 image ("Read_Frames (1)").
- 11- ground (or MTL) sends TC(130,80) for the read-out of the new VMC image (picture_03) into the SSMM.
- 12- after 42 s from 11, ground (or MTL) sends TC(2,2) for the configuration of VMC (exposure_time_04).
- 13- ground (or MTL) sends TC(2,2) for the acquisition of 1 image ("Read_Frames (1)").
- 14- ground (or MTL) sends TC(130,80) for the read-out of the new VMC image (picture_04) into the SSMM.
- 15- after 42 s from 14, ground (or MTL) sends TC(2,2) for the configuration of VMC (exposure_time_05).
- 16- ground (or MTL) sends TC(2,2) for the acquisition of 1 image ("Read_Frames (1)").
- 17- ground (or MTL) sends TC(130,80) for the read-out of the new VMC image (picture_05) into the SSMM.
- 18- after 42 s from 17, ground (or MTL) sends TC(2,2) for the configuration of VMC (exposure_time_06).
- 19- ground (or MTL) sends TC(2,2) for the acquisition of 1 image ("Read_Frames (1)").
- 20- ground (or MTL) sends TC(130,80) for the read-out of the new VMC image (picture_06) into the SSMM.
- 21- after 42 s from 20, ground (or MTL) sends TC(2,2) for the configuration of VMC (exposure_time_07).
- 22- ground (or MTL) sends TC(2,2) for the acquisition of 1 image ("Read_Frames (1)").

-
- 23- ground (or MTL) sends TC(130,80) for the read-out of the new VMC image (picture_07) into the SSMM.
 - 24- after 42 s from 23, ground (or MTL) sends TC(2,2) for the configuration of VMC (exposure_time_08).
 - 25- ground (or MTL) sends TC(2,2) for the acquisition of 1 image ("Read_Frames (1)").
 - 26- ground (or MTL) sends TC(130,80) for the read-out of the new VMC image (picture_08) into the SSMM.
 - 27- after 42 s from 26, ground (or MTL) sends TC(2,2) for the configuration of VMC (exposure_time_09).
 - 28- ground (or MTL) sends TC(2,2) for the acquisition of 1 image ("Read_Frames (1)").
 - 29- ground (or MTL) sends TC(130,80) for the read-out of the new VMC image (picture_09) into the SSMM.
 - 30- after 42 s from 29, ground (or MTL) sends TC(2,2) for the configuration of VMC (exposure_time_10).
 - 31- ground (or MTL) sends TC(2,2) for the acquisition of 1 image ("Read_Frames (1)").
 - 32- ground (or MTL) sends TC(130,80) for the read-out of the new VMC image (picture_10) into the SSMM.
 - 33- after 42 s from 32, ground (or MTL) sends TC(2,2) for the configuration of VMC (exposure_time_11).
 - 34- ground (or MTL) sends TC(2,2) for the acquisition of 1 image ("Read_Frames (1)").
 - 35- ground (or MTL) sends TC(130,80) for the read-out of the new VMC image (picture_11) into the SSMM.
 - 36- after 42 s from 35, ground (or MTL) sends TC(2,2) for the configuration of VMC (exposure_time_12).
 - 37- ground (or MTL) sends TC(2,2) for the acquisition of 1 image ("Read_Frames (1)").
 - 38- ground (or MTL) sends TC(130,80) for the read-out of the new VMC image (picture_12) into the SSMM.
 - 39- after 42 s from 38, ground (or MTL) sends TC(2,2) for the configuration of VMC (exposure_time_13).
 - 40- ground (or MTL) sends TC(2,2) for the acquisition of 1 image ("Read_Frames (1)").
 - 41- ground (or MTL) sends TC(130,80) for the read-out of the new VMC image (picture_13) into the SSMM.
 - 42- after 42 s from 41, ground (or MTL) sends TC(2,2) for the configuration of VMC (exposure_time_14).
 - 43- ground (or MTL) sends TC(2,2) for the acquisition of 1 image ("Read_Frames (1)").
 - 44- ground (or MTL) sends TC(130,80) for the read-out of the new VMC image (picture_14) into the SSMM.
 - 45- after 42 s from 44, ground (or MTL) sends TC(2,2) for the configuration of VMC (exposure_time_105).
 - 46- ground (or MTL) sends TC(2,2) for the acquisition of 1 image ("Read_Frames (1)").
 - 47- ground (or MTL) sends TC(130,80) for the read-out of the new VMC image (picture_15) into the SSMM.
 - 48- after 42 s from 47, ground (or MTL) sends TC(2,2) for the configuration of VMC (exposure_time_16).
 - 49- ground (or MTL) sends TC(2,2) for the acquisition of 1 image ("Read_Frames (1)").

-
- 50- ground (or MTL) sends TC(130,80) for the read-out of the new VMC image (picture_16) into the SSMM.
 - 51- after 42 s from 50, ground (or MTL) sends TC(2,2) for the configuration of VMC (exposure_time_17).
 - 52- ground (or MTL) sends TC(2,2) for the acquisition of 1 image ("Read_Frames (1)").
 - 53- ground (or MTL) sends TC(130,80) for the read-out of the new VMC image (picture_17) into the SSMM.
 - 54- after 42 s from 53, ground (or MTL) sends TC(2,2) for the configuration of VMC (exposure_time_18).
 - 55- ground (or MTL) sends TC(2,2) for the acquisition of 1 image ("Read_Frames (1)").
 - 56- ground (or MTL) sends TC(130,80) for the read-out of the new VMC image (picture_18) into the SSMM.
 - 57- after 42 s from 56, ground (or MTL) sends TC(2,2) for the configuration of VMC (exposure_time_19).
 - 58- ground (or MTL) sends TC(2,2) for the acquisition of 1 image ("Read_Frames (1)").
 - 59- ground (or MTL) sends TC(130,80) for the read-out of the new VMC image (picture_19) into the SSMM.
 - 60- after 42 s from 59, ground (or MTL) sends TC(2,2) for the configuration of VMC (exposure_time_20).
 - 61- ground (or MTL) sends TC(2,2) for the acquisition of 1 image ("Read_Frames (1)").
 - 62- ground (or MTL) sends TC(130,80) for the read-out of the new VMC image (picture_20) into the SSMM.
 - 63- after 42 s from 32, ground switches off VMC and interface to the OBDH.
 - 64- when appropriate, ground (or MTL) sends TC for the downlink of the 20 images from the SSMM.

6.1.2.2 *Earth Verification activities*

Objective: checkout of the VMC and exposure times calibration

Date/time: proper time to be decided by ESOC

Duration: 1 hour minimum, up to a complete working day

The following sequence (34 steps) enables the acquisition and download to ground of 10 images with different exposure times. These 10 images will be processed to get knowledge about the illumination conditions in space and determine the proper exposure times to use for the ejection of the Beagle2 probe. This sequence requires appreciatively 30 minutes of operations and may have to be repeated several times to tune the exposure times. Indeed, the process of computing proper exposure times will take more or less time, depending on the degree of similarity between the attitude of Mars Express spacecraft with respect to the Sun and its attitude at beagle2 ejection. It is obvious that the ideal

configuration is to have similar attitudes. In any case, scaling with respect to Sun intensity will be necessary to determine adequate exposure time when at Mars-Sun distance.

The minimum number of images to acquire to get a complete sequence of the beagle2 separation will also be refined at that stage. It is set to 10 at the moment: After (Fired-but-still-attached + 500) s at 0.3 m/s, the B2 would be at 150m. But finer computation needs to be done to determine for how long the geometry allows Beagle2 to be visible (assuming that it would be illuminated and reflecting) if the SC keeps the same attitude. These calibration activities will also lead to a better definition of the proof of the Beagle2 ejection (a completely dark picture except an illuminated crescent getting smaller and smaller?).

- 1- ground (or MTL) switches on the VMC and interface to the OBDH.
- 2- after 150 s from 1, ground (or MTL) sends TC(130,80) for the read-out of the VMC's 1st image (default settings).
- 3- after 42 s from 2, ground (or MTL) sends TC(2,2) for the configuration of VMC (exposure_time_01).
- 4- ground (or MTL) sends TC(2,2) for the acquisition of 1 image ("Read_Frames (1)").
- 5- ground (or MTL) sends TC(130,80) for the read-out of the new VMC image (picture_01) into the SSMM.
- 6- after 42 s from 5, ground (or MTL) sends TC(2,2) for the configuration of VMC (exposure_time_02).
- 7- ground (or MTL) sends TC(2,2) for the acquisition of 1 image ("Read_Frames (1)").
- 8- ground (or MTL) sends TC(130,80) for the read-out of the new VMC image (picture_02) into the SSMM.
- 9- after 42 s from 8, ground (or MTL) sends TC(2,2) for the configuration of VMC (exposure_time_03).
- 10- ground (or MTL) sends TC(2,2) for the acquisition of 1 image ("Read_Frames (1)").
- 11- ground (or MTL) sends TC(130,80) for the read-out of the new VMC image (picture_03) into the SSMM.
- 12- after 42 s from 11, ground (or MTL) sends TC(2,2) for the configuration of VMC (exposure_time_04).
- 13- ground (or MTL) sends TC(2,2) for the acquisition of 1 image ("Read_Frames (1)").
- 14- ground (or MTL) sends TC(130,80) for the read-out of the new VMC image (picture_04) into the SSMM.
- 15- after 42 s from 14, ground (or MTL) sends TC(2,2) for the configuration of VMC (exposure_time_05).
- 16- ground (or MTL) sends TC(2,2) for the acquisition of 1 image ("Read_Frames (1)").
- 17- ground (or MTL) sends TC(130,80) for the read-out of the new VMC image (picture_05) into the SSMM.
- 18- after 42 s from 17, ground (or MTL) sends TC(2,2) for the configuration of VMC (exposure_time_06).
- 19- ground (or MTL) sends TC(2,2) for the acquisition of 1 image ("Read_Frames (1)").
- 20- ground (or MTL) sends TC(130,80) for the read-out of the new VMC image (picture_06) into the SSMM.

- 21- after 42 s from 20, ground (or MTL) sends TC(2,2) for the configuration of VMC (exposure_time_07).
- 22- ground (or MTL) sends TC(2,2) for the acquisition of 1 image ("Read_Frames (1)").
- 23- ground (or MTL) sends TC(130,80) for the read-out of the new VMC image (picture_07) into the SSMM.
- 24- after 42 s from 23, ground (or MTL) sends TC(2,2) for the configuration of VMC (exposure_time_08).
- 25- ground (or MTL) sends TC(2,2) for the acquisition of 1 image ("Read_Frames (1)").
- 26- ground (or MTL) sends TC(130,80) for the read-out of the new VMC image (picture_08) into the SSMM.
- 27- after 42 s from 26, ground (or MTL) sends TC(2,2) for the configuration of VMC (exposure_time_09).
- 28- ground (or MTL) sends TC(2,2) for the acquisition of 1 image ("Read_Frames (1)").
- 29- ground (or MTL) sends TC(130,80) for the read-out of the new VMC image (picture_09) into the SSMM.
- 30- after 42 s from 29, ground (or MTL) sends TC(2,2) for the configuration of VMC (exposure_time_10).
- 31- ground (or MTL) sends TC(2,2) for the acquisition of 1 image ("Read_Frames (1)").
- 32- ground (or MTL) sends TC(130,80) for the read-out of the new VMC image (picture_10) into the SSMM.
- 33- after 42 s from 32, ground switches off VMC and interface to the OBDH.
- 34- when appropriate, ground (or MTL) sends TC for the downlink of the 10 images from the SSMM.

6.1.2.3 *Interplanetary Cruise activities*

Objective: last checkout of the VMC and of the VMC imaging sequence for Beagle2 ejection

Date/time: around two months before Mars orbit insertion, exact time to be decided by ESOC

Duration: 30 minutes minimum, up to 1 hour

The last checkout of the VMC/Beagle2 separation activities should take place as late as possible during the Interplanetary Cruise but soon enough to avoid interfering with the horrendous last 10 days when all activities and manoeuvres for Mars approach take place (see Flight Dynamics Technical Note). Two months before arrival (late Oct-03) seems good enough to be confident that the VMC will work on the day of B2 ejection. If an extra late check-out is required (which is NOT recommend), it should happen at least 1 week before the Beagle2 ejection proper – actual date remaining TBC with respect to ops constraints.

Note that for this final checkout, the attitude of the Mars Express spacecraft will NOT be made similar to the ejection attitude.

The Beagle2 separation image sequence will contain at least 10 pictures that require 34 steps of the following procedure. But the possibility to get more images should be kept. ESOC/operations will make the final decision during Earth Verification or Interplanetary Cruise phases. The following sequence enables the acquisition and download to ground of 20 images with different exposure times. So the steps 1 to 32 and 63 to 64 are compulsory while the execution of the steps 33 to 62 depends on the total number of images allowed.

- 65- ground (or MTL) switches on the VMC and interface to the OBDH.
- 66- after 150 s from 1, ground (or MTL) sends TC(130,80) for the read-out of the VMC's 1st image (default settings).
- 67- after 42 s from 2, ground (or MTL) sends TC(2,2) for the configuration of VMC (exposure_time_01).
- 68- ground (or MTL) sends TC(2,2) for the acquisition of 1 image ("Read_Frames (1)").
- 69- ground (or MTL) sends TC(130,80) for the read-out of the new VMC image (picture_01) into the SSMM.
- 70- after 42 s from 5, ground (or MTL) sends TC(2,2) for the configuration of VMC (exposure_time_02).
- 71- ground (or MTL) sends TC(2,2) for the acquisition of 1 image ("Read_Frames (1)").
- 72- ground (or MTL) sends TC(130,80) for the read-out of the new VMC image (picture_02) into the SSMM.
- 73- after 42 s from 8, ground (or MTL) sends TC(2,2) for the configuration of VMC (exposure_time_03).
- 74- ground (or MTL) sends TC(2,2) for the acquisition of 1 image ("Read_Frames (1)").
- 75- ground (or MTL) sends TC(130,80) for the read-out of the new VMC image (picture_03) into the SSMM.
- 76- after 42 s from 11, ground (or MTL) sends TC(2,2) for the configuration of VMC (exposure_time_04).
- 77- ground (or MTL) sends TC(2,2) for the acquisition of 1 image ("Read_Frames (1)").
- 78- ground (or MTL) sends TC(130,80) for the read-out of the new VMC image (picture_04) into the SSMM.
- 79- after 42 s from 14, ground (or MTL) sends TC(2,2) for the configuration of VMC (exposure_time_05).
- 80- ground (or MTL) sends TC(2,2) for the acquisition of 1 image ("Read_Frames (1)").
- 81- ground (or MTL) sends TC(130,80) for the read-out of the new VMC image (picture_05) into the SSMM.
- 82- after 42 s from 17, ground (or MTL) sends TC(2,2) for the configuration of VMC (exposure_time_06).
- 83- ground (or MTL) sends TC(2,2) for the acquisition of 1 image ("Read_Frames (1)").
- 84- ground (or MTL) sends TC(130,80) for the read-out of the new VMC image (picture_06) into the SSMM.

-
- 85- after 42 s from 20, ground (or MTL) sends TC(2,2) for the configuration of VMC (exposure_time_07).
- 86- ground (or MTL) sends TC(2,2) for the acquisition of 1 image ("Read_Frames (1)").
- 87- ground (or MTL) sends TC(130,80) for the read-out of the new VMC image (picture_07) into the SSMM.
- 88- after 42 s from 23, ground (or MTL) sends TC(2,2) for the configuration of VMC (exposure_time_08).
- 89- ground (or MTL) sends TC(2,2) for the acquisition of 1 image ("Read_Frames (1)").
- 90- ground (or MTL) sends TC(130,80) for the read-out of the new VMC image (picture_08) into the SSMM.
- 91- after 42 s from 26, ground (or MTL) sends TC(2,2) for the configuration of VMC (exposure_time_09).
- 92- ground (or MTL) sends TC(2,2) for the acquisition of 1 image ("Read_Frames (1)").
- 93- ground (or MTL) sends TC(130,80) for the read-out of the new VMC image (picture_09) into the SSMM.
- 94- after 42 s from 29, ground (or MTL) sends TC(2,2) for the configuration of VMC (exposure_time_10).
- 95- ground (or MTL) sends TC(2,2) for the acquisition of 1 image ("Read_Frames (1)").
- 96- ground (or MTL) sends TC(130,80) for the read-out of the new VMC image (picture_10) into the SSMM.
- 97- after 42 s from 32, ground (or MTL) sends TC(2,2) for the configuration of VMC (exposure_time_11).
- 98- ground (or MTL) sends TC(2,2) for the acquisition of 1 image ("Read_Frames (1)").
- 99- ground (or MTL) sends TC(130,80) for the read-out of the new VMC image (picture_11) into the SSMM.
- 100- after 42 s from 35, ground (or MTL) sends TC(2,2) for the configuration of VMC (exposure_time_12).
- 101- ground (or MTL) sends TC(2,2) for the acquisition of 1 image ("Read_Frames (1)").
- 102- ground (or MTL) sends TC(130,80) for the read-out of the new VMC image (picture_12) into the SSMM.
- 103- after 42 s from 38, ground (or MTL) sends TC(2,2) for the configuration of VMC (exposure_time_13).
- 104- ground (or MTL) sends TC(2,2) for the acquisition of 1 image ("Read_Frames (1)").
- 105- ground (or MTL) sends TC(130,80) for the read-out of the new VMC image (picture_13) into the SSMM.
- 106- after 42 s from 41, ground (or MTL) sends TC(2,2) for the configuration of VMC (exposure_time_14).
- 107- ground (or MTL) sends TC(2,2) for the acquisition of 1 image ("Read_Frames (1)").
- 108- ground (or MTL) sends TC(130,80) for the read-out of the new VMC image (picture_14) into the SSMM.
- 109- after 42 s from 44, ground (or MTL) sends TC(2,2) for the configuration of VMC (exposure_time_105).
- 110- ground (or MTL) sends TC(2,2) for the acquisition of 1 image ("Read_Frames (1)").
- 111- ground (or MTL) sends TC(130,80) for the read-out of the new VMC image (picture_15) into the SSMM.

-
- 112- after 42 s from 47, ground (or MTL) sends TC(2,2) for the configuration of VMC (exposure_time_16).
- 113- ground (or MTL) sends TC(2,2) for the acquisition of 1 image ("Read_Frames (1)").
- 114- ground (or MTL) sends TC(130,80) for the read-out of the new VMC image (picture_16) into the SSMM.
- 115- after 42 s from 50, ground (or MTL) sends TC(2,2) for the configuration of VMC (exposure_time_17).
- 116- ground (or MTL) sends TC(2,2) for the acquisition of 1 image ("Read_Frames (1)").
- 117- ground (or MTL) sends TC(130,80) for the read-out of the new VMC image (picture_17) into the SSMM.
- 118- after 42 s from 53, ground (or MTL) sends TC(2,2) for the configuration of VMC (exposure_time_18).
- 119- ground (or MTL) sends TC(2,2) for the acquisition of 1 image ("Read_Frames (1)").
- 120- ground (or MTL) sends TC(130,80) for the read-out of the new VMC image (picture_18) into the SSMM.
- 121- after 42 s from 56, ground (or MTL) sends TC(2,2) for the configuration of VMC (exposure_time_19).
- 122- ground (or MTL) sends TC(2,2) for the acquisition of 1 image ("Read_Frames (1)").
- 123- ground (or MTL) sends TC(130,80) for the read-out of the new VMC image (picture_19) into the SSMM.
- 124- after 42 s from 59, ground (or MTL) sends TC(2,2) for the configuration of VMC (exposure_time_20).
- 125- ground (or MTL) sends TC(2,2) for the acquisition of 1 image ("Read_Frames (1)").
- 126- ground (or MTL) sends TC(130,80) for the read-out of the new VMC image (picture_20) into the SSMM.
- 127- after 42 s from 32, ground switches off VMC and interface to the OBDH.
- 128- when appropriate, ground (or MTL) sends TC for the downlink of the 20 images from the SSMM.

6.1.2.4 Preparation activities for Beagle2 separation

- Objective:** start of the imaging sequence of Beagle2 ejection
- Date/time:** actual date/time remaining TBC with respect to ops constraints
- Duration:** 10 minutes minimum, up to 20 minutes

To minimise as far as possible interleaving VMC activities and the critical Pyro sequences which lead to the Beagle2 ejection, the set-up of the VMC and acquisition/polling of the first image (with default exposure time) must take place around two hours before B2 separation (actual time TBD) when „nothing else“ happens (avoid mixing with power or AOCS TCs to turn the spacecraft). A second image

(with proper exposure time) must also be acquired and stored in the SSMM as a reference picture with respect to Beagle2 separation.

This first image is then taken and read out to the SSMM (not to the Earth) when the spacecraft is still pointing Earth.

- 1- ground (or MTL) switches on the VMC and interface to the OBDH.
- 2- after 150 s from 1, ground (or MTL) sends TC(130,80) for the read-out of the VMC's 1st image (default settings).
- 3- after 42 s from 2, ground (or MTL) sends TC(2,2) for the configuration of VMC (exposure_time_01).
- 4- ground (or MTL) sends TC(2,2) for the acquisition of 1 image ("Read_Frames (1)").
- 5- ground (or MTL) sends TC(130,80) for the read-out of the new VMC image (picture_01) into the SSMM.
- 6- after 42 s from 5, ground (or MTL) sends TC(2,2) for the configuration of VMC (exposure_time_02).

6.1.2.5 Beagle2 separation activities

Objective: actual imaging sequence of Beagle2 ejection

Date/time: actual date/time remaining TBC with respect to ops constraints

Duration: 30 minutes minimum, up to 1 hour

At this stage, the VMC is ON and the first image (default exposure time settings) has already been acquired and transferred to the SSMM. Moreover, the exposure parameters (mode and exposure_time_01) for the first image of the sequence have already been sent to the VMC. The camera is then ready to execute the first Read_Frames command and the following sequence.

This sequence should start only when the pyro safing is finished – a couple of seconds after the ejection proper - possibly before the Beagle2 is even ejected. But so the TC interleaving would be avoided.

The Beagle2 separation image sequence will contain at least 10 pictures that require 34 steps of the following procedure. But the possibility to get more images should be kept. ESOC/operations will make the final decision during Earth Verification or Interplanetary Cruise phases. The following sequence enables the acquisition and download to ground of 20 images with different exposure times. So the steps 1 to 29 and 60 to 61 are compulsory while the execution of the steps 30 to 59 depends on the total number of images allowed.

- 7- ground (or MTL) sends TC(2,2) for the acquisition of 1 image ("Read_Frames (1)").
- 8- ground (or MTL) sends TC(130,80) for the read-out of the new VMC image (picture_01) into the SSMM.
- 9- after 42 s from 5, ground (or MTL) sends TC(2,2) for the configuration of VMC (exposure_time_02).
- 10- ground (or MTL) sends TC(2,2) for the acquisition of 1 image ("Read_Frames (1)").
- 11- ground (or MTL) sends TC(130,80) for the read-out of the new VMC image (picture_02) into the SSMM.
- 12- after 42 s from 8, ground (or MTL) sends TC(2,2) for the configuration of VMC (exposure_time_03).
- 13- ground (or MTL) sends TC(2,2) for the acquisition of 1 image ("Read_Frames (1)").
- 14- ground (or MTL) sends TC(130,80) for the read-out of the new VMC image (picture_03) into the SSMM.
- 15- after 42 s from 11, ground (or MTL) sends TC(2,2) for the configuration of VMC (exposure_time_04).
- 16- ground (or MTL) sends TC(2,2) for the acquisition of 1 image ("Read_Frames (1)").
- 17- ground (or MTL) sends TC(130,80) for the read-out of the new VMC image (picture_04) into the SSMM.
- 18- after 42 s from 14, ground (or MTL) sends TC(2,2) for the configuration of VMC (exposure_time_05).
- 19- ground (or MTL) sends TC(2,2) for the acquisition of 1 image ("Read_Frames (1)").
- 20- ground (or MTL) sends TC(130,80) for the read-out of the new VMC image (picture_05) into the SSMM.
- 21- after 42 s from 17, ground (or MTL) sends TC(2,2) for the configuration of VMC (exposure_time_06).
- 22- ground (or MTL) sends TC(2,2) for the acquisition of 1 image ("Read_Frames (1)").
- 23- ground (or MTL) sends TC(130,80) for the read-out of the new VMC image (picture_06) into the SSMM.
- 24- after 42 s from 20, ground (or MTL) sends TC(2,2) for the configuration of VMC (exposure_time_07).
- 25- ground (or MTL) sends TC(2,2) for the acquisition of 1 image ("Read_Frames (1)").
- 26- ground (or MTL) sends TC(130,80) for the read-out of the new VMC image (picture_07) into the SSMM.
- 27- after 42 s from 23, ground (or MTL) sends TC(2,2) for the configuration of VMC (exposure_time_08).
- 28- ground (or MTL) sends TC(2,2) for the acquisition of 1 image ("Read_Frames (1)").
- 29- ground (or MTL) sends TC(130,80) for the read-out of the new VMC image (picture_08) into the SSMM.
- 30- after 42 s from 26, ground (or MTL) sends TC(2,2) for the configuration of VMC (exposure_time_09).
- 31- ground (or MTL) sends TC(2,2) for the acquisition of 1 image ("Read_Frames (1)").
- 32- ground (or MTL) sends TC(130,80) for the read-out of the new VMC image (picture_09) into the SSMM.
- 33- after 42 s from 29, ground (or MTL) sends TC(2,2) for the configuration of VMC (exposure_time_10).

-
- 34- ground (or MTL) sends TC(2,2) for the acquisition of 1 image ("Read_Frames (1)").
 - 35- ground (or MTL) sends TC(130,80) for the read-out of the new VMC image (picture_10) into the SSMM.
 - 36- after 42 s from 32, ground (or MTL) sends TC(2,2) for the configuration of VMC (exposure_time_11).
 - 37- ground (or MTL) sends TC(2,2) for the acquisition of 1 image ("Read_Frames (1)").
 - 38- ground (or MTL) sends TC(130,80) for the read-out of the new VMC image (picture_11) into the SSMM.
 - 39- after 42 s from 35, ground (or MTL) sends TC(2,2) for the configuration of VMC (exposure_time_12).
 - 40- ground (or MTL) sends TC(2,2) for the acquisition of 1 image ("Read_Frames (1)").
 - 41- ground (or MTL) sends TC(130,80) for the read-out of the new VMC image (picture_12) into the SSMM.
 - 42- after 42 s from 38, ground (or MTL) sends TC(2,2) for the configuration of VMC (exposure_time_13).
 - 43- ground (or MTL) sends TC(2,2) for the acquisition of 1 image ("Read_Frames (1)").
 - 44- ground (or MTL) sends TC(130,80) for the read-out of the new VMC image (picture_13) into the SSMM.
 - 45- after 42 s from 41, ground (or MTL) sends TC(2,2) for the configuration of VMC (exposure_time_14).
 - 46- ground (or MTL) sends TC(2,2) for the acquisition of 1 image ("Read_Frames (1)").
 - 47- ground (or MTL) sends TC(130,80) for the read-out of the new VMC image (picture_14) into the SSMM.
 - 48- after 42 s from 44, ground (or MTL) sends TC(2,2) for the configuration of VMC (exposure_time_105).
 - 49- ground (or MTL) sends TC(2,2) for the acquisition of 1 image ("Read_Frames (1)").
 - 50- ground (or MTL) sends TC(130,80) for the read-out of the new VMC image (picture_15) into the SSMM.
 - 51- after 42 s from 47, ground (or MTL) sends TC(2,2) for the configuration of VMC (exposure_time_16).
 - 52- ground (or MTL) sends TC(2,2) for the acquisition of 1 image ("Read_Frames (1)").
 - 53- ground (or MTL) sends TC(130,80) for the read-out of the new VMC image (picture_16) into the SSMM.
 - 54- after 42 s from 50, ground (or MTL) sends TC(2,2) for the configuration of VMC (exposure_time_17).
 - 55- ground (or MTL) sends TC(2,2) for the acquisition of 1 image ("Read_Frames (1)").
 - 56- ground (or MTL) sends TC(130,80) for the read-out of the new VMC image (picture_17) into the SSMM.
 - 57- after 42 s from 53, ground (or MTL) sends TC(2,2) for the configuration of VMC (exposure_time_18).
 - 58- ground (or MTL) sends TC(2,2) for the acquisition of 1 image ("Read_Frames (1)").
 - 59- ground (or MTL) sends TC(130,80) for the read-out of the new VMC image (picture_18) into the SSMM.
 - 60- after 42 s from 56, ground (or MTL) sends TC(2,2) for the configuration of VMC (exposure_time_19).

- 61- ground (or MTL) sends TC(2,2) for the acquisition of 1 image ("Read_Frames (1)").
- 62- ground (or MTL) sends TC(130,80) for the read-out of the new VMC image (picture_19) into the SSMM.
- 63- after 42 s from 59, ground (or MTL) sends TC(2,2) for the configuration of VMC (exposure_time_20).
- 64- ground (or MTL) sends TC(2,2) for the acquisition of 1 image ("Read_Frames (1)").
- 65- ground (or MTL) sends TC(130,80) for the read-out of the new VMC image (picture_20) into the SSMM.
- 66- after 42 s from 32, ground switches off VMC and interface to the OBDH.
- 67- when appropriate, ground (or MTL) sends TC for the downlink of the 20 images from the SSMM.

Figure 6.1. Fine time-line diagram of a typical VMC activity

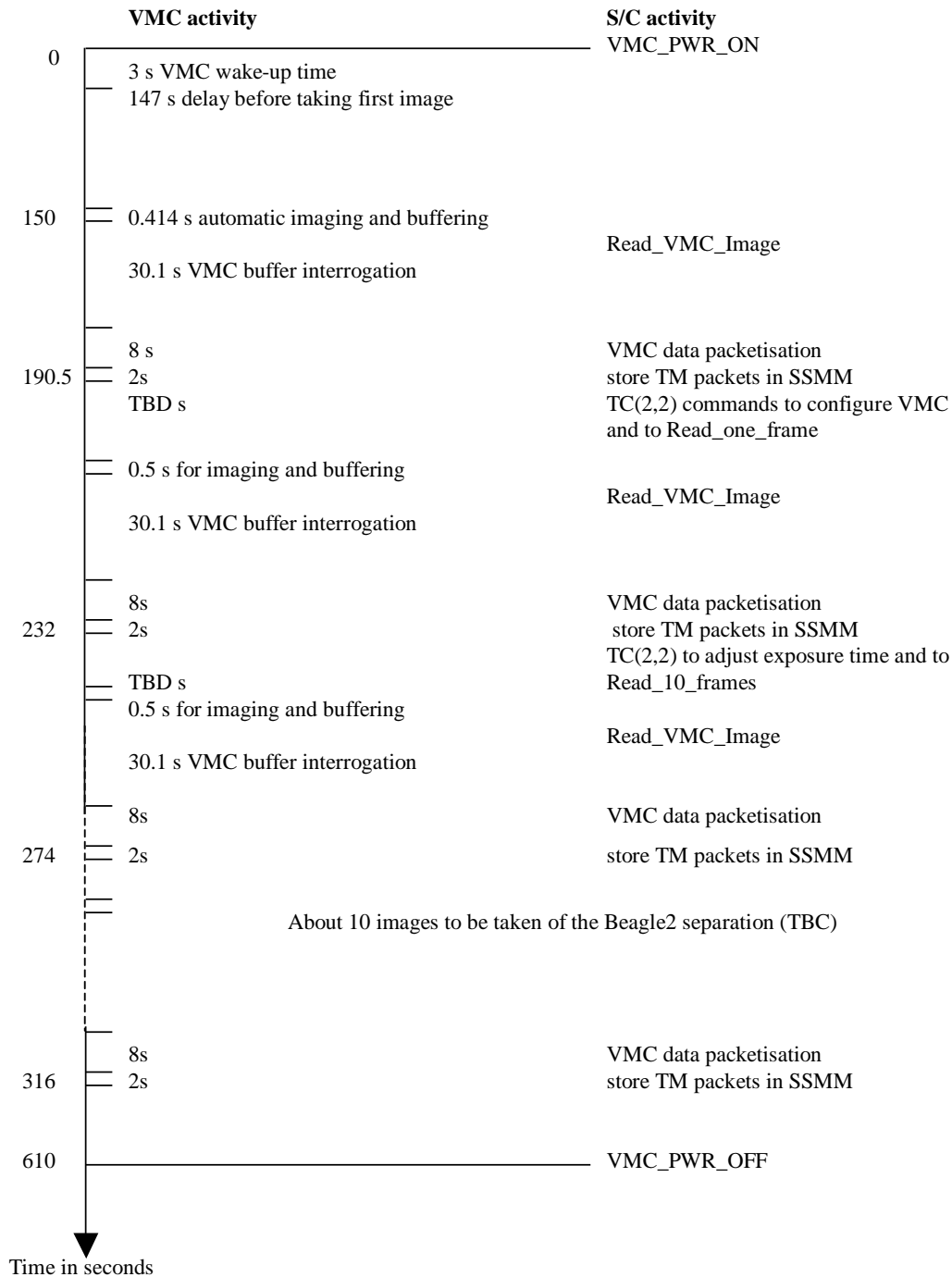

6.1.3 ROLE OF THE VMC “PI”

During each activity described in section 6.1 (System Validation Tests, Earth Validation, Interplanetary Cruise, Beagle2 separation preparation and Beagle2 ejection), a specialist of the VMC will be available on site or on line to check the prepared commands and process/interpret the downlinked data using the VMC SCOE software described in section 8.

6.2 *Operation of the VMC camera system*

The camera is switched ON during flight with the default parameter settings as indicated in section 5.1.

After the special RTU table for polling the VMC memories is selected by telecommand the image data of the VMC is first stored in the mass memory where it is ready to be downlinked. The first image can be read any number of times from the buffer by subsequent TTC-B-01 TM16 interrogation cycles.

The first in-flight command to the VMC cameras will only be accepted after the first image has been downloaded and correctly received by the VMC SCOE. This first command will be to acquire the next images.

6.2.1 COMMANDS TO THE VMC CAMERA

The command to RESET the camera is as follows:

Table 6.2.1.

Activity	TC_Command	Argument
VMC reset	00000100	00000100

To command the camera to read a new image is:

Table 6.2.2.

Activity	TC_Command	Argument	Remarks
VMC Read_Frames	0000100P _f	A _f	see table 6.2.3.

The values for P_f (parity bit) and A_f for the number of images to acquire and read one after the other can be replaced using the numbers in table 6.2.3.:

Table 6.2.3.

Activity	P _f	A _f
----------	----------------	----------------

ReadFrames (1)	1	0
ReadFrames (2)	0	1
ReadFrames (3)	0	2
ReadFrames (4)	1	3
ReadFrames (5)	0	4
ReadFrames (6)	1	5
ReadFrames (7)	1	6
ReadFrames (8)	0	7
ReadFrames (9)	0	8
ReadFrames (10)	1	9
Etc.		
ReadFrames (20)	0	19
Etc.		
ReadFrames (endless)	0	128

This will command the camera to acquire a new image with the default settings and store them in the memories. The RTU takes care that the cameras are subsequently interrogated.

So if, after ground processing, new images are needed with different exposure settings then the following commands will be used:

Table 6.2.4a. VMC Exposure setting in line mode

Activity	TC_Command	Argument	Remarks
VMC reset	00000100	00000100	
VMC SetModeLines	10010011	00000000	
VMC SetExposure	1000011P _t	A _t	see table 6.2.5a
VMC Read_Frames	0000100 P _f	A _f	see table 6.2.3.

or

Table 6.2.4b. VMC Exposure setting in frame mode

Activity	TC_Command	Argument	Remarks
VMC reset	00000100	00000100	
VMC SetModeFrames	10010010	00010000	
VMC SetExposure	1000011 P _t	A _t	see table 6.2.5b
VMC Read_Frames	0000100 P _f	A _f	see table 6.2.3.

Tables 6.2.5a and b on the next pages provide the nominal values for P_t (parity bit) and A_t (raw exposure time setting) for the line mode and for the frame mode respectively.

The exposure time setting need to be given by the customer **in milliseconds**. The GPU shall convert it using look-up tables conform to tables 6.2.5a and b. The two relevant numbers will be given to the operator, whereupon the he shall generate the required TC_Command with its argument.

Table 6.2.5a. VMC Exposure Time for Exposure Mode = 0 (Set ModeLines).

T ms	Pt	At	T ms	Pt	At	T ms	Pt	At	T ms	Pt	At	T ms	Pt	At
0.4	1	0	41.2	1	51	82	1	102	122.8	1	153	163.6	1	204
1.2	0	1	42	0	52	82.8	0	103	123.6	1	154	164.4	0	205
2	0	2	42.8	1	53	83.6	0	104	124.4	0	155	165.2	0	206
2.8	1	3	43.6	1	54	84.4	1	105	125.2	1	156	166	1	207
3.6	0	4	44.4	0	55	85.2	1	106	126	0	157	166.8	0	208
4.4	1	5	45.2	0	56	86	0	107	126.8	0	158	167.6	1	209
5.2	1	6	46	1	57	86.8	1	108	127.6	1	159	168.4	1	210
6	0	7	46.8	1	58	87.6	0	109	128.4	1	160	169.2	0	211
6.8	0	8	47.6	0	59	88.4	0	110	129.2	0	161	170	1	212
7.6	1	9	48.4	1	60	89.2	1	111	130	0	162	170.8	0	213
8.4	1	10	49.2	0	61	90	0	112	130.8	1	163	171.6	0	214
9.2	0	11	50	0	62	90.8	1	113	131.6	0	164	172.4	1	215
10	1	12	50.8	1	63	91.6	1	114	132.4	1	165	173.2	1	216
10.8	0	13	51.6	0	64	92.4	0	115	133.2	1	166	174	0	217
11.6	0	14	52.4	1	65	93.2	1	116	134	0	167	174.8	0	218
12.4	1	15	53.2	1	66	94	0	117	134.8	0	168	175.6	1	219
13.2	0	16	54	0	67	94.8	0	118	135.6	1	169	176.4	0	220
14	1	17	54.8	1	68	95.6	1	119	136.4	1	170	177.2	1	221
14.8	1	18	55.6	0	69	96.4	1	120	137.2	0	171	178	1	222
15.6	0	19	56.4	0	70	97.2	0	121	138	1	172	178.8	0	223
16.4	1	20	57.2	1	71	98	0	122	138.8	0	173	179.6	0	224
17.2	0	21	58	1	72	98.8	1	123	139.6	0	174	180.4	1	225
18	0	22	58.8	0	73	99.6	0	124	140.4	1	175	181.2	1	226
18.8	1	23	59.6	0	74	100.4	1	125	141.2	0	176	182	0	227
19.6	1	24	60.4	1	75	101.2	1	126	142	1	177	182.8	1	228
20.4	0	25	61.2	0	76	102	0	127	142.8	1	178	183.6	0	229
21.2	0	26	62	1	77	102.8	0	128	143.6	0	179	184.4	0	230
22	1	27	62.8	1	78	103.6	1	129	144.4	1	180	185.2	1	231
22.8	0	28	63.6	0	79	104.4	1	130	145.2	0	181	186	1	232
23.6	1	29	64.4	1	80	105.2	0	131	146	0	182	186.8	0	233
24.4	1	30	65.2	0	81	106	1	132	146.8	1	183	187.6	0	234
25.2	0	31	66	0	82	106.8	0	133	147.6	1	184	188.4	1	235
26	0	32	66.8	1	83	107.6	0	134	148.4	0	185	189.2	0	236
26.8	1	33	67.6	0	84	108.4	1	135	149.2	0	186	190	1	237
27.6	1	34	68.4	1	85	109.2	1	136	150	1	187	190.8	1	238
28.4	0	35	69.2	1	86	110	0	137	150.8	0	188	191.6	0	239
29.2	1	36	70	0	87	110.8	0	138	151.6	1	189			
30	0	37	70.8	0	88	111.6	1	139	152.4	1	190			
30.8	0	38	71.6	1	89	112.4	0	140	153.2	0	191			
31.6	1	39	72.4	1	90	113.2	1	141	154	1	192			
32.4	1	40	73.2	0	91	114	1	142	154.8	0	193			
33.2	0	41	74	1	92	114.8	0	143	155.6	0	194			

S

34	0	42	74.8	0	93	115.6	1	144	156.4	1	195
34.8	1	43	75.6	0	94	116.4	0	145	157.2	0	196
35.6	0	44	76.4	1	95	117.2	0	146	158	1	197
36.4	1	45	77.2	1	96	118	1	147	158.8	1	198
37.2	1	46	78	0	97	118.8	0	148	159.6	0	199
38	0	47	78.8	0	98	119.6	1	149	160.4	0	200
38.8	1	48	79.6	1	99	120.4	1	150	161.2	1	201
39.6	0	49	80.4	0	100	121.2	0	151	162	1	202
40.4	0	50	81.2	1	101	122	0	152	162.8	0	203

Table 6.2.5b. VMC Exposure Time for Exposure Mode = 1 (Set ModeFrames).

T ms	Pt	At	T ms	Pt	At	T ms	Pt	At	T ms	Pt	At	T ms	Pt	At
200	1	0	20600	1	51	41000	1	102	61400	1	153	81800	1	204
600	0	1	21000	0	52	41400	0	103	61800	1	154	82200	0	205
1000	0	2	21400	1	53	41800	0	104	62200	0	155	82600	0	206
1400	1	3	21800	1	54	42200	1	105	62600	1	156	83000	1	207
1800	0	4	22200	0	55	42600	1	106	63000	0	157	83400	0	208
2200	1	5	22600	0	56	43000	0	107	63400	0	158	83800	1	209
2600	1	6	23000	1	57	43400	1	108	63800	1	159	84200	1	210
3000	0	7	23400	1	58	43800	0	109	64200	1	160	84600	0	211
3400	0	8	23800	0	59	44200	0	110	64600	0	161	85000	1	212
3800	1	9	24200	1	60	44600	1	111	65000	0	162	85400	0	213
4200	1	10	24600	0	61	45000	0	112	65400	1	163	85800	0	214
4600	0	11	25000	0	62	45400	1	113	65800	0	164	86200	1	215
5000	1	12	25400	1	63	45800	1	114	66200	1	165	86600	1	216
5400	0	13	25800	0	64	46200	0	115	66600	1	166	87000	0	217
5800	0	14	26200	1	65	46600	1	116	67000	0	167	87400	0	218
6200	1	15	26600	1	66	47000	0	117	67400	0	168	87800	1	219
6600	0	16	27000	0	67	47400	0	118	67800	1	169	88200	0	220
7000	1	17	27400	1	68	47800	1	119	68200	1	170	88600	1	221
7400	1	18	27800	0	69	48200	1	120	68600	0	171	89000	1	222
7800	0	19	28200	0	70	48600	0	121	69000	1	172	89400	0	223
8200	1	20	28600	1	71	49000	0	122	69400	0	173	89800	0	224
8600	0	21	29000	1	72	49400	1	123	69800	0	174	90200	1	225
9000	0	22	29400	0	73	49800	0	124	70200	1	175	90600	1	226
9400	1	23	29800	0	74	50200	1	125	70600	0	176	91000	0	227
9800	1	24	30200	1	75	50600	1	126	71000	1	177	91400	1	228
10200	0	25	30600	0	76	51000	0	127	71400	1	178	91800	0	229
10600	0	26	31000	1	77	51400	0	128	71800	0	179	92200	0	230
11000	1	27	31400	1	78	51800	1	129	72200	1	180	92600	1	231
11400	0	28	31800	0	79	52200	1	130	72600	0	181	93000	1	232
11800	1	29	32200	1	80	52600	0	131	73000	0	182	93400	0	233
12200	1	30	32600	0	81	53000	1	132	73400	1	183	93800	0	234
12600	0	31	33000	0	82	53400	0	133	73800	1	184	94200	1	235
13000	0	32	33400	1	83	53800	0	134	74200	0	185	94600	0	236
13400	1	33	33800	0	84	54200	1	135	74600	0	186	95000	1	237
13800	1	34	34200	1	85	54600	1	136	75000	1	187	95400	1	238
14200	0	35	34600	1	86	55000	0	137	75400	0	188	95800	0	239
14600	1	36	35000	0	87	55400	0	138	75800	1	189			
15000	0	37	35400	0	88	55800	1	139	76200	1	190			
15400	0	38	35800	1	89	56200	0	140	76600	0	191			
15800	1	39	36200	1	90	56600	1	141	77000	1	192			
16200	1	40	36600	0	91	57000	1	142	77400	0	193			
16600	0	41	37000	1	92	57400	0	143	77800	0	194			
17000	0	42	37400	0	93	57800	1	144	78200	1	195			
17400	1	43	37800	0	94	58200	0	145	78600	0	196			
17800	0	44	38200	1	95	58600	0	146	79000	1	197			
18200	1	45	38600	1	96	59000	1	147	79400	1	198			
18600	1	46	39000	0	97	59400	0	148	79800	0	199			
19000	0	47	39400	0	98	59800	1	149	80200	0	200			
19400	1	48	39800	1	99	60200	1	150	80600	1	201			
19800	0	49	40200	0	100	60600	0	151	81000	1	202			
20200	0	50	40600	1	101	61000	0	152	81400	0	203			

7 SUMMARY OF TELECOMMAND AND TELEMETRY DATA

7.1 *Telecommand list*

TELECOMMAND LIST			INSTRUMENT: VMC		MODEL:
ACRONYM	DESCRIPTION	APID	DATA PATTERN		REMARKS
			COMMAND	ARGUMENT	
VMC_PWR_ON	VMC HPC ON CMD				
VMCRESET	Reset all parameters to default		00000100	00000100	
VMCLINES	Set to line mode		10010011	00000000	
VMCFRAME	Set to frame mode		10010010	00010000	
VMCEXPOS	Set required exposure time		1000011P _t	A _t see table 6.2.5a&b	
VMCREADF	Read number of picture frames		0000100 P _f	A _f see table 6.2.3.	
VMC_PWR_OFF	VMC HPC OFF CMD				

7.2 Telemetry list

TELEMETRY LIST			INSTRUMENT: VMC		MODEL:
ACRONYM	DESCRIPTION	APID	DATA PATTERN		REMARKS
			COMMAND	ARGUMENT	
READ_VMC_IMAGE	Read VMC image buffer				
PACKET_STORE_ID	Packetised VMC image report				1 image is 76 TM packets
VMC_THER	VMC temperature (ANC)				

8 VMC SCOE DESCRIPTION AND OPERATION

This part is still under readjustment for Mars Express and is subject to change.

Effacé de 5.2 et à intégrer quelque part dans 8.:

The VMC controller continuously monitors the 5.0Vdc supply voltage of the image sensor. When this supply drops below approximately 2.8 Vdc for more than 160 ns, the controller stops driving the sensor, and an alarm message, which will be displayed on the VMC SCOE screen, is sent with any subsequent data output requested (see SystemStatus byte in section 5.1). Such a condition would occur during latch-up of the sensor. The correct end-user reaction is then to power-cycle the VMC, i.e. the VMC operator should as soon as possible send a command to power-off and power-on the VMC (it is not known how long the VMC can survive such a latch-up protection state).

8.1 *The VMC SCOE*

The VMC SCOE system consists of an Intel Pentium based PC connected to the instrument LAN and running MS Windows 2000.

The VMC SCOE software has been developed in MS Visual C++ 6.0 (for MS Windows 32 bit OS).

8.2 *The VMC SCOE software*

The format of the VMC data is encoded according to a tailored version of the CCSDS PUS: Source Packets are not used; the data is only encapsulated in Transfer Frames. (see Appendix B and [RD 1] for a complete description).

The VMC SCOE software processes binary files containing Transfer Frames and performs consistency check discarding irrelevant and erroneous Frames. These files must be stored on the VMC SCOE hard disk drive before processing. The procedure to get these files onto the VMC SCOE hard disk drive is described in the MEX DDID ([RD7]).

When the VMC SCOE SW processes MEX data files, Transfer Frame headers and trailers are stripped off and camera data is collected. From the VMC data, the original image is then reconstructed and ancillary (image number and VMC health status) data is retrieved. VMC data start and end sync markers are checked in order to verify whether the data was correctly transmitted or to re-synchronise in case of loss of synchronisation.

The reconstructed B&W images are then displayed on the screen and automatically saved on the hard disk drive in raw format (*.RAW). Colour images can be extracted from the raw image files using an external executable (TBD) and saved as bitmap format (*.BMP).

Adobe Photoshop is installed on the VMC SCOE so that some post processing tools/filters can be applied to the images: contrast and luminosity adjustment, sharpening and smoothing, bad pixels removal (if present) and colour processing.

8.3 MEX VMC Ground Processing Operation

8.3.1 VMC DATA PROCESSING

Step 1

Switch on the PC and login to the MS Windows 2000 OS:

User ID: vmc
Password: vmc

The Windows 2000 desktop will appear on the screen. Click on Windows Explorer. The directory tree will be displayed.

Step 2

Select and go to **E:\MEX\VMC**. Make a copy the folder **template folder for MEX VMC data processing** and rename it to the appropriate name (e.g. “MEX VMC EFVB2” or “MEX VMC Beagle2 separation”). The content of this folder should look like the following (see right part of the Explorer window):

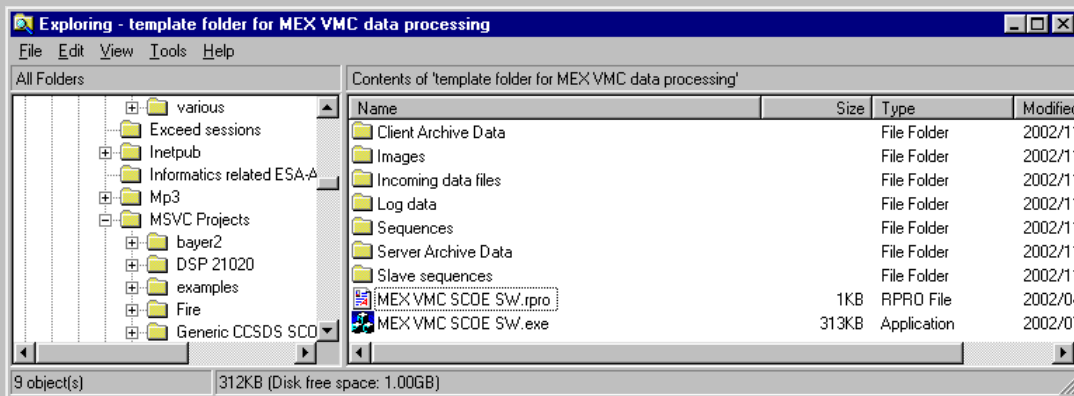

Step 3

Run the **MEX VMC SCOE SW.exe** executable. It should open a new document named “Document1” by default.

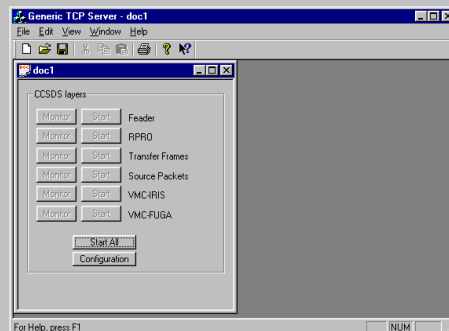

Step 4

Close the “Document1” and open the document “MEX VMC SCOE SW.rpro”:

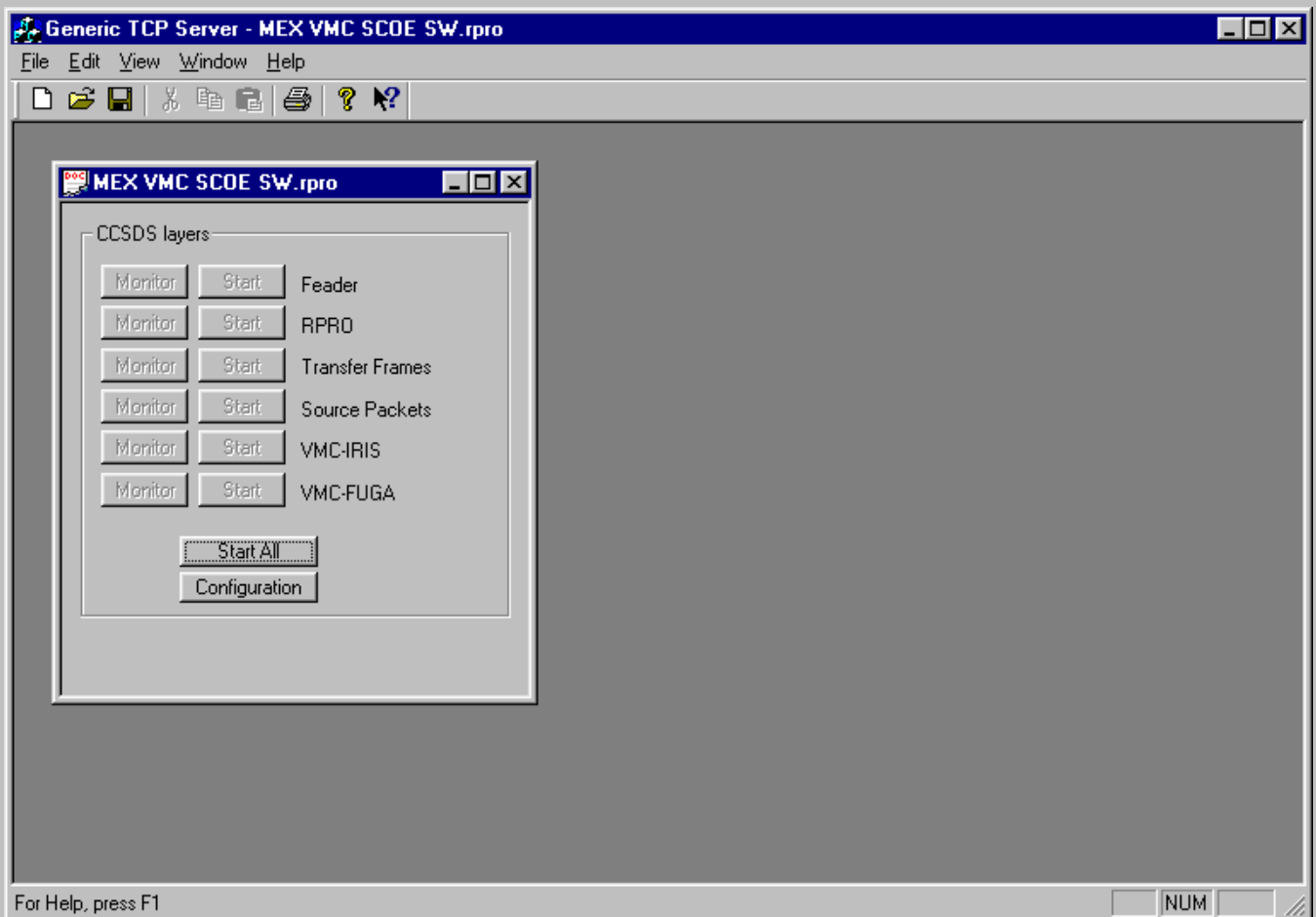
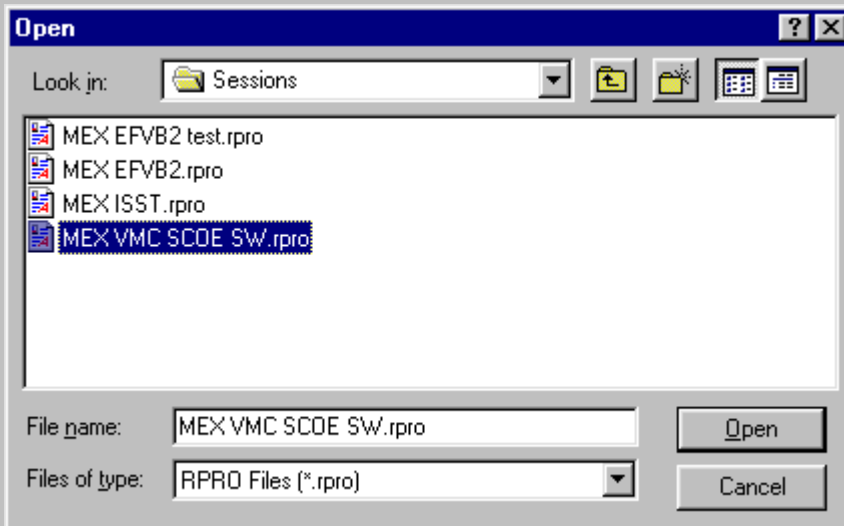

Step 5

Enlarge the document and reduce the size of the application:

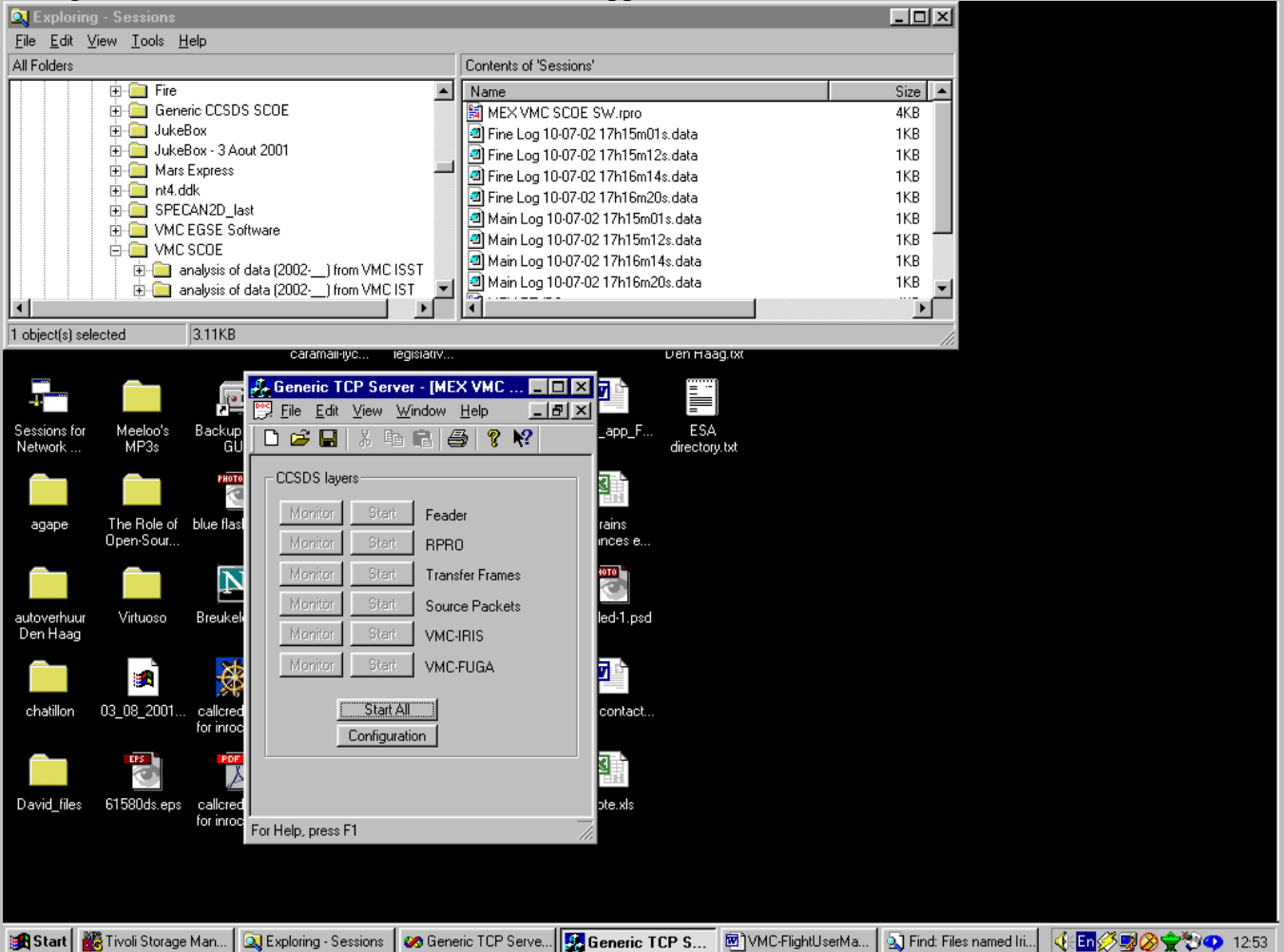

Step 6

Click on  to check the configuration of the CCSDS decoder:

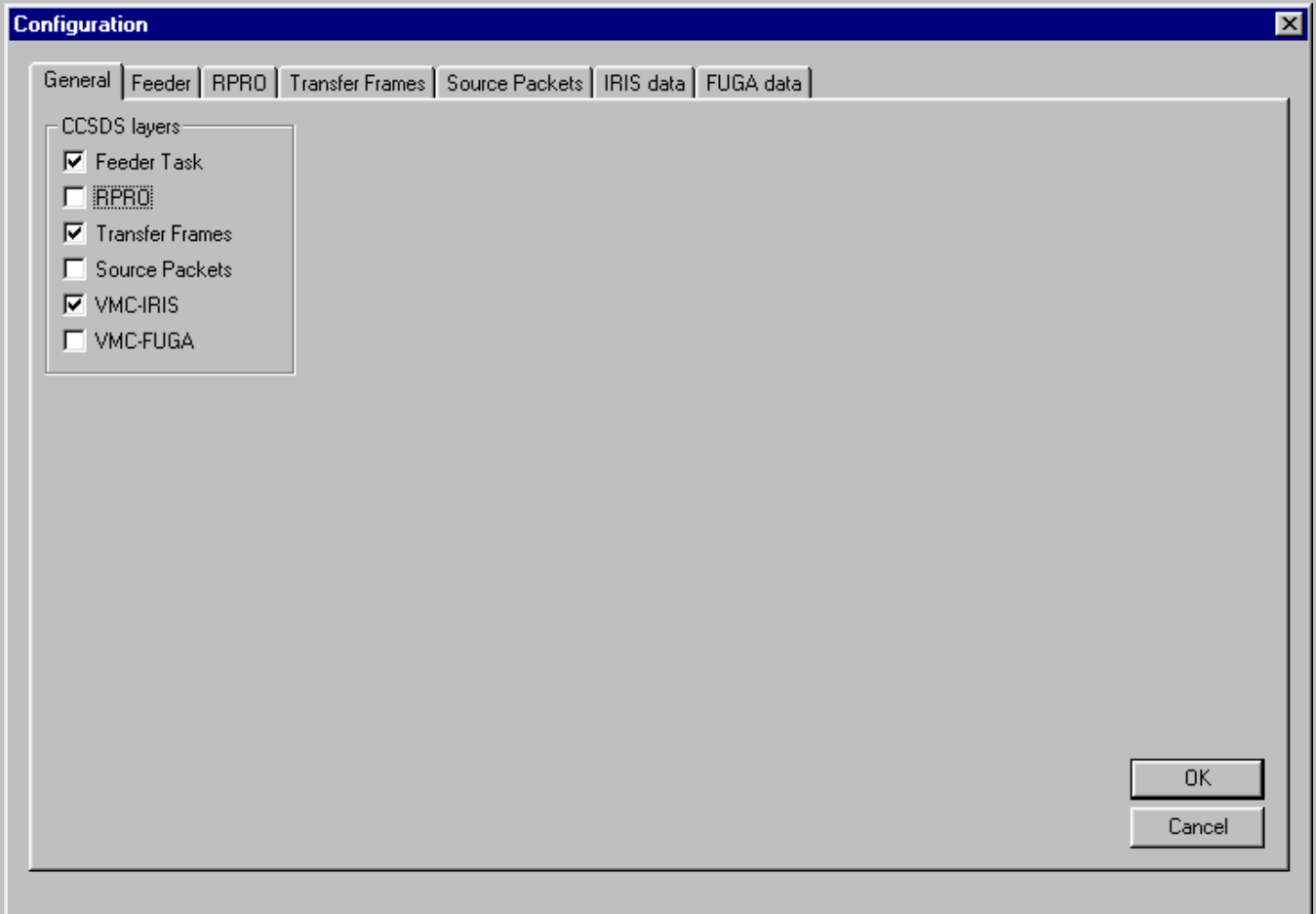

Only Feeder, Transfer Frames and VMC IRIS are selected because these are the decoding layers used to retrieve the content of VMC data from MEX.

Step 7

In the Feeder tab, fill in the box Incoming data file with the path and name of the VMC data file to process. The button allows selecting this file from a location on the hard disk drive.

The screenshot shows the 'Configuration' dialog box with the 'Feeder' tab selected. The dialog has a title bar with a close button (X) and a menu bar with tabs: General, Feeder, RPRO, Transfer Frames, Source Packets, IRIS data, and FUGA data. The 'Feeder' tab contains the following fields and controls:

- Decoder type:** (Label)
- Thread name:**
- Log file name:**
- Input buffer:**
- Output channel:** **buffer:**
- Throw data
- Monitor
- Header:**
 - Length:
 - Pattern:
 - Mask:
 - Size of search:
- Trailer:**
 - Length:
 - Pattern:
 - Mask:
- Body:**
 - Fixed length
 - Variable length field
 - Length: Position:
 - Length:
- Incoming data stream:**
 - TCP/IP connexion
 - Reading from file(s)
 - Address:
 - Port for RPRO connexion:
- Log incoming and outgoing data

Buttons:

All other tabs should not be modified:

Configuration [X]

General | Feeder | RPRD | **Transfer Frames** | Source Packets | IRIS data | FUGA data

Decoder type: Frame Decoder (MEX EFVB2)
 Thread name: Frame Decoder
 Log file name: Frame Decoder

Input buffer: 1
 Output channel: 205 buffer: 205
 Throw data
 Monitor

Header
 Length: 16
 Pattern: 136096426
 Mask: 4294901760
 Size of search: 128

Trailer
 Length: 0
 Pattern: 0
 Mask: 0

Body
 Fixed length Variable length field
 Length: 4096 Position: 205
 Length: 205

OK
 Cancel

Configuration [X]

General | Feeder | RPRD | Transfer Frames | **IRIS data** | FUGA data

Decoder type: IRIS Data Decoder Thread
 Thread name: IRIS Data Decoder
 Log file name: IRIS Data Decoder

Input buffer: 3
 Output channel: 205 buffer: 205
 Throw data
 Monitor

Header
 Length: 6
 Pattern: 4278255360
 Mask: 4294967295
 Size of search: 200

Trailer
 Length: 4
 Pattern: 4276992716
 Mask: 4294967295

Body
 Fixed length Variable length field
 Length: 307200 Position: 205
 Length: 205

OK
 Cancel

Step 8

Click on OK to load the updated configuration and get back to the main window:

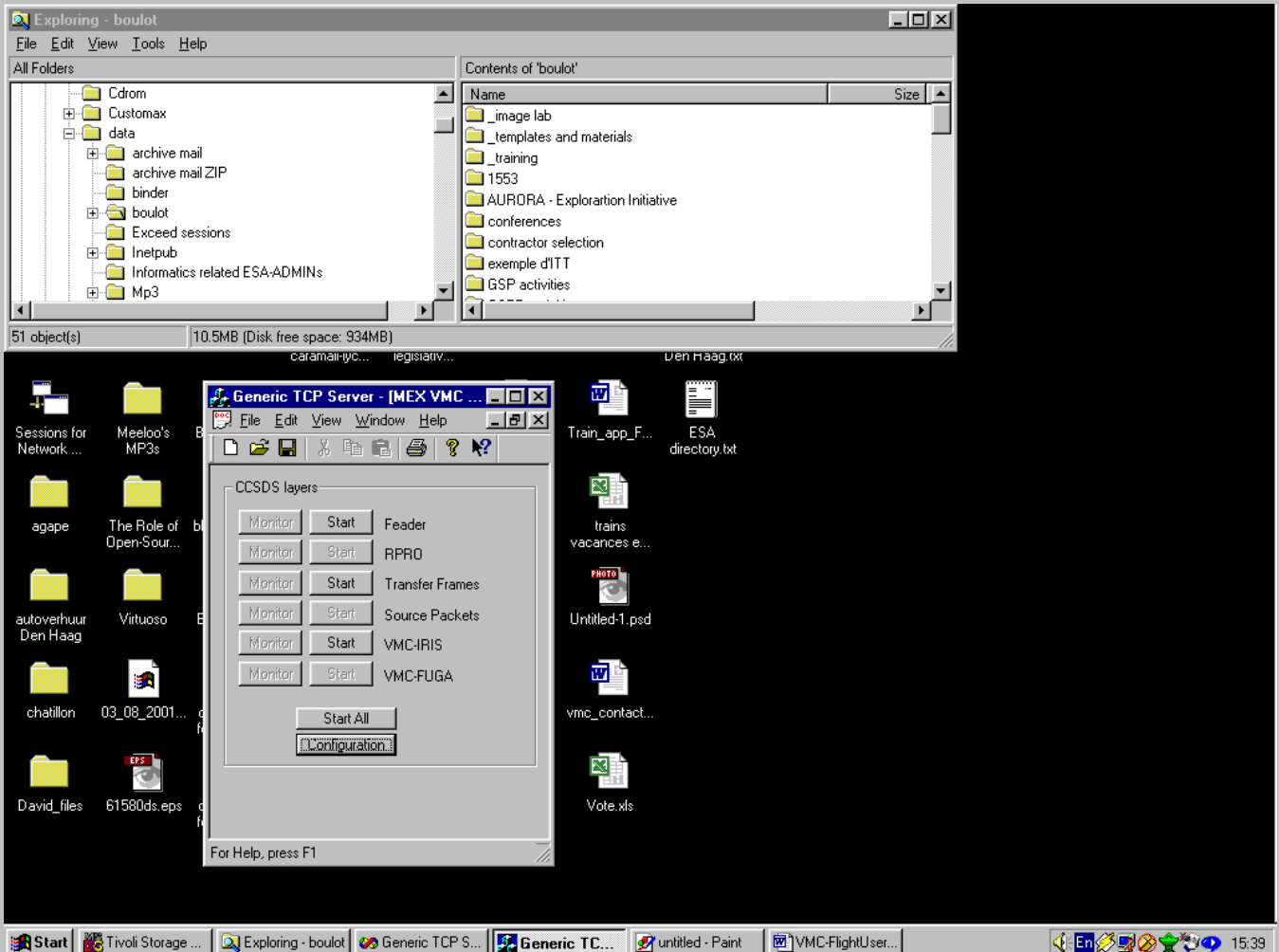

Step 9

Click on to start the decoding:

[screen shot TBA]

The monitor windows for the selected decoding layers appear on the screen:

[screen shot TBA]

The Feeder Monitor indicates the number of bytes read from the input VMC data file and the corresponding data rate.

[screen shot TBA]

The Transfer Frame Monitor shows the number of Frames decoded from the incoming byte stream.

[screen shot TBA]

The VMC IRIS Monitor shows the image being extracted from VMC data and the corresponding VMC health status but also the last complete image and the corresponding VMC health status.

[screen shot TBA]

The complete images are automatically stored in raw format (*.RAW files) in the \Images subfolder.

Step 10

When needed, click on [Stop All] to stop the processing and close all monitor windows:

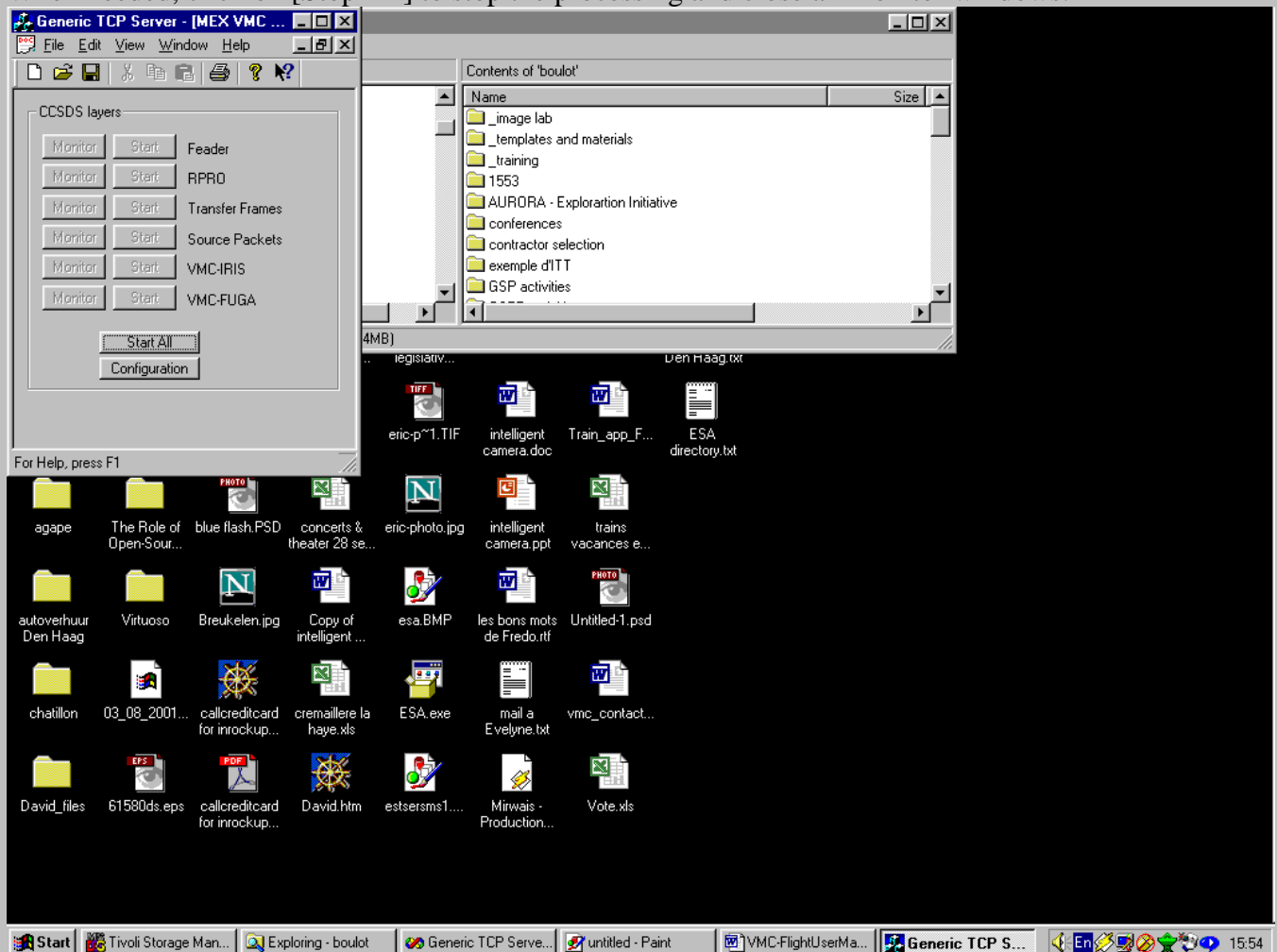

The processing can be resumed by clicking on again.

Step 10

When needed, close the application.

8.3.2 OFF-LINE IMAGE PROCESSING

The VMC is based on a linear colour sensor so VMC raw images require colour processing and gamma-correction to produce colour images. In off-line mode this can be performed using the program **IrisCol.exe**.

Step 1

Open a command line window and get to the subfolder **\Images**:

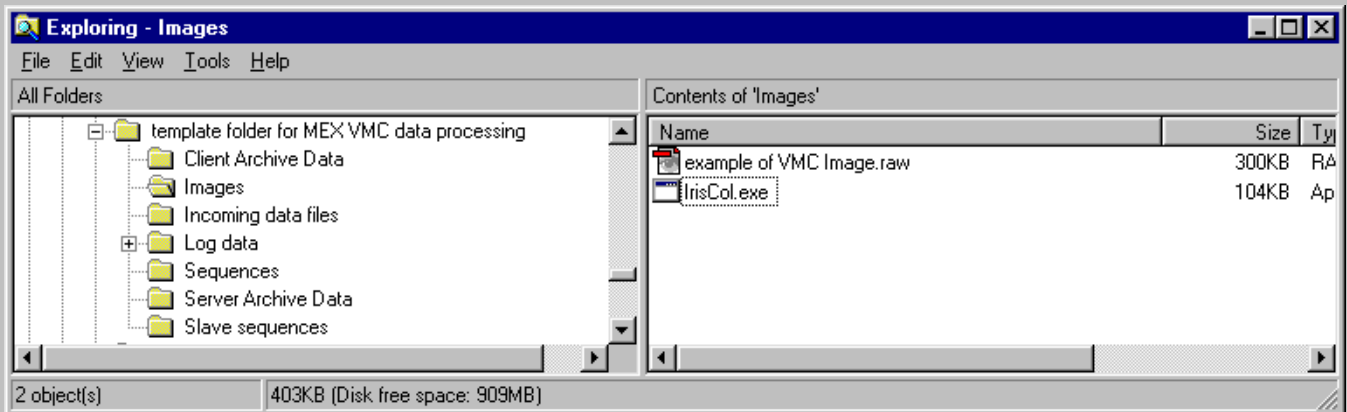

Step 2

From the command line window, run the command

```
IrisCol "name of the raw image file"
```

Note that the name of the raw file to post-process should not contain the file extension “.RAW”

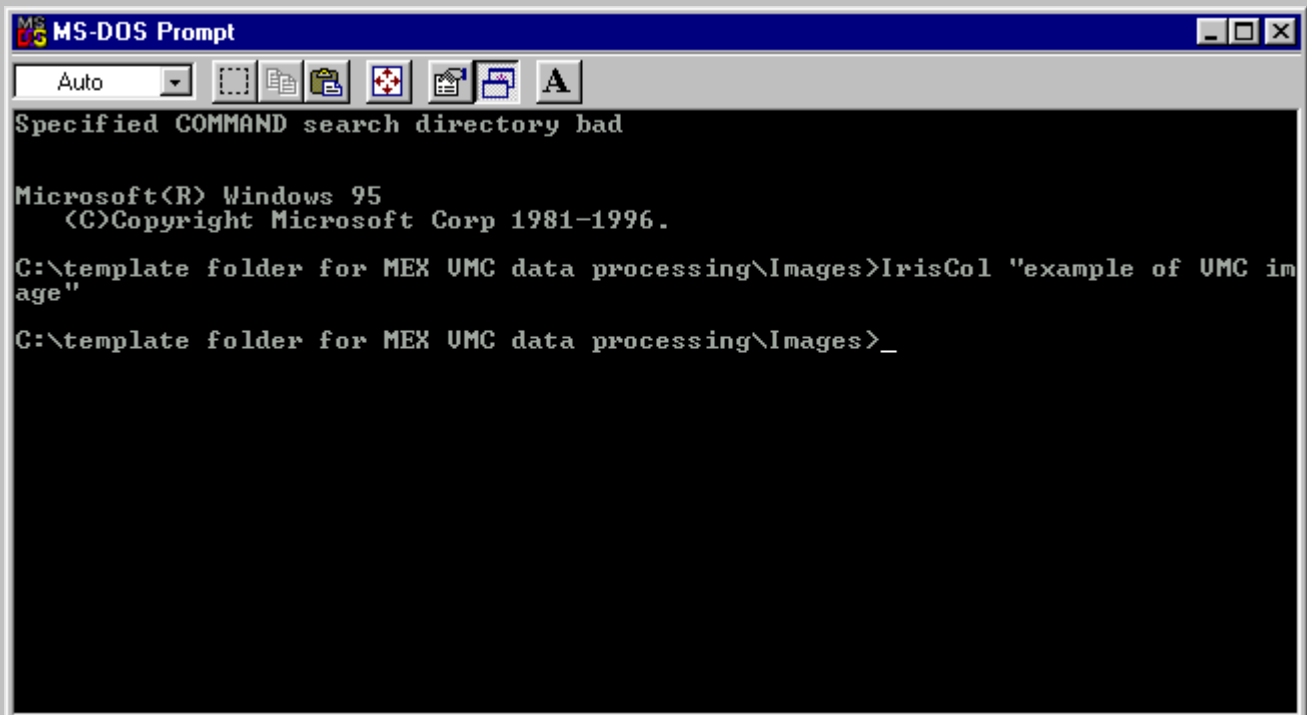

When the prompt is returned, a bitmap file (*.BMP) has been created with the same name:

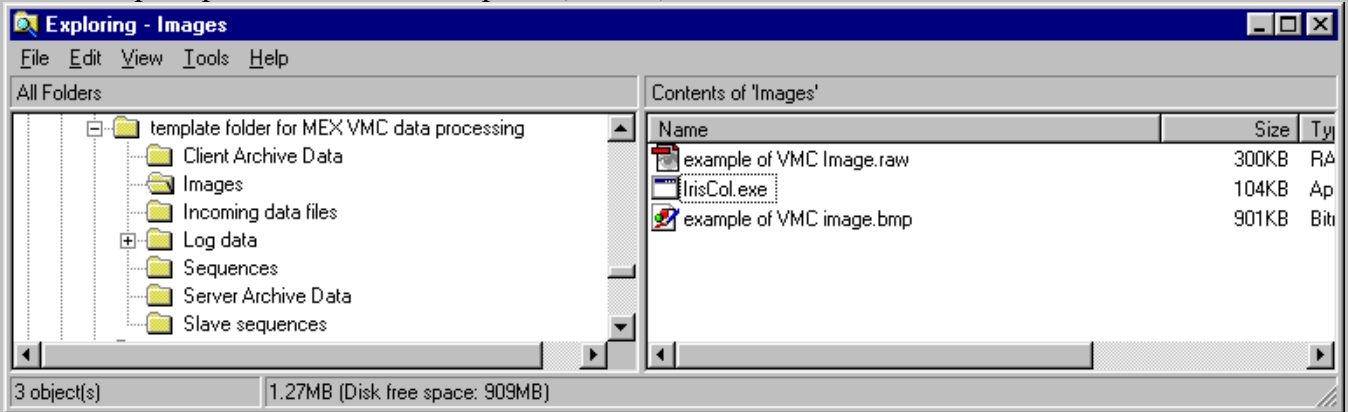

9 APPENDIX A: MECHANICAL LAYOUT

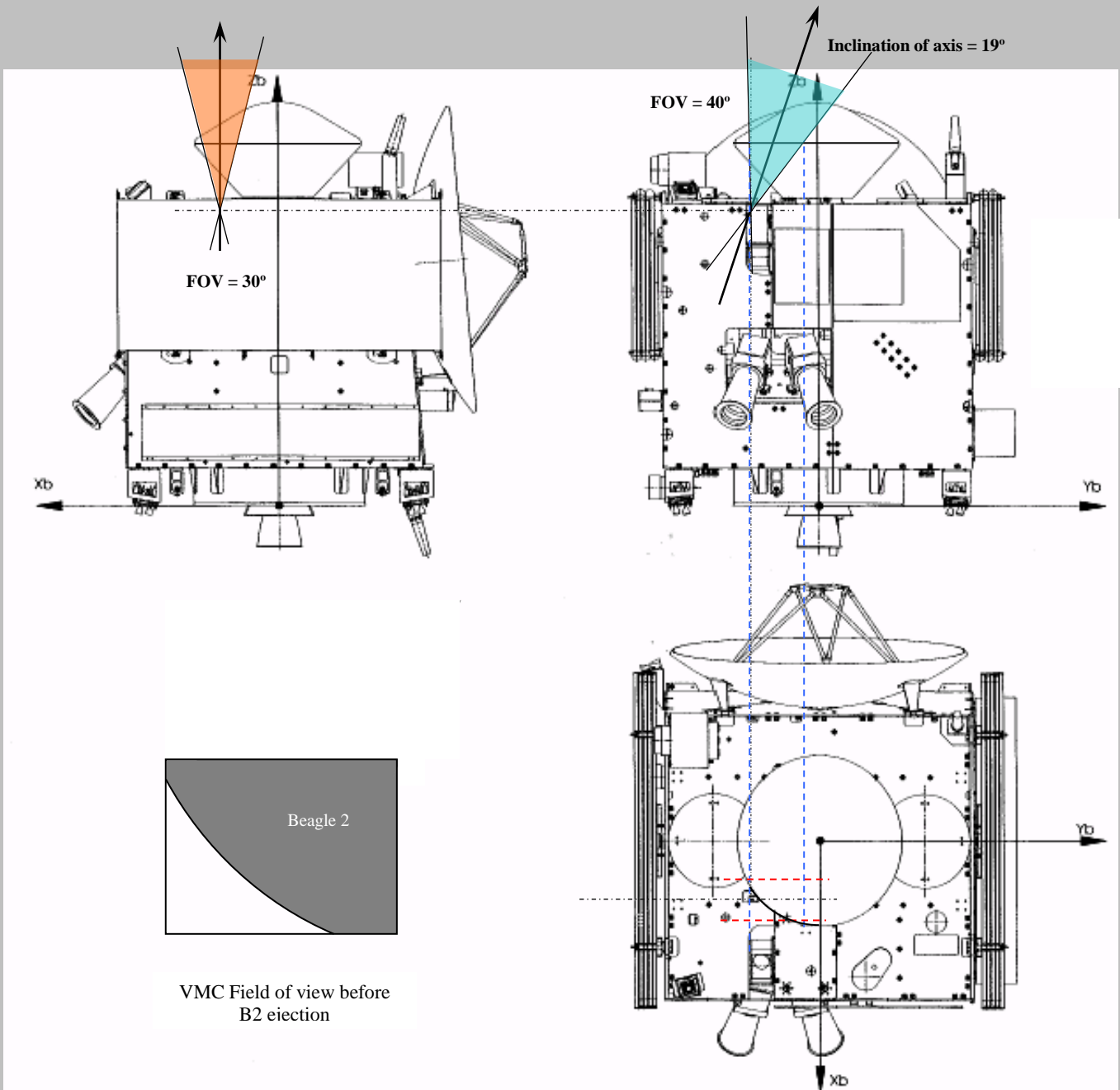

10 APPENDIX B: TRANSFER FRAMES AND VMC DATA FIELD LAY-OUT

10.1 Transfer Frames and VMC data field Lay-out

Octet nr.	nr of bits	Content	hex	Comment
0	2	Version nr.	00	Fixed
	6	Spacecraft ID	03	
1	4	Spacecraft ID	7	Spacecraft ID = MEX=037H
	3	Virtual Channel ID	3	
	1	Ops Ctrl Field flag	1	
2		Master Channel Frame Counter	Nn	Counting
3		Virtual Channel Frame Counter	Nn	Counting
4		Frame data field status	9F	Fixed
5		Frame data field status	FF	Fixed
6		Secondary Header ID	03	Fixed
7		Secondary Header data	00	24 additional bits of VC frame counter
8		Secondary Header data	00	
9		Secondary Header data	01	
10		Data Field	data	4096 octets of payload data
11		Data Field	data	
12		Data Field	data	
13		Data Field	data	
14		Data Field	data	
15		Data Field	data	
---		---	data	
4105		Data Field	data	
4106		OCF	nn	4 octets of Operational Control Field
---		---	---	
4109		OCF	nn	
4110		Frame Error Control Field	nn	2 octets
4111		Frame Error Control Field	nn	

Transfer Frame length is constant = 4112 octets.

10.2 Data Field Lay-out for VMC image data

Octet nr.	nr of bits	Content	Comment	
			hex	
0	8	Sync Marker	FF	
1	8	Sync Marker	00	
2	8	Sync Marker	FF	
3	8	Sync Marker	00	
4	8	Image ID	00 - FF	1 - 255
5	5	spare	2	
	2	Timeout status	3	00 = operational 01 = timeout but operational 10 = timeout and interface non-operational
	1	System status	0 or 1	0 = Latch-up and 1 = OK
6	8	Pixel value	00 - FF	Pixel value is from 1 - 255
7	8	Pixel value	00 - FF	Unsigned integer
8	8	Pixel value	00 - FF	255 = full white
	8			
N-3	8	End marker	FE	
N-2	8	End marker	ED	
N-1	8	End marker	BA	
N	8	End marker	CC	
N+1	8	Sync Marker	FF	Sync header of next image
N+2		Etc.	data	

11 APPENDIX C: VMC CIRCUIT SCHEMATICS.

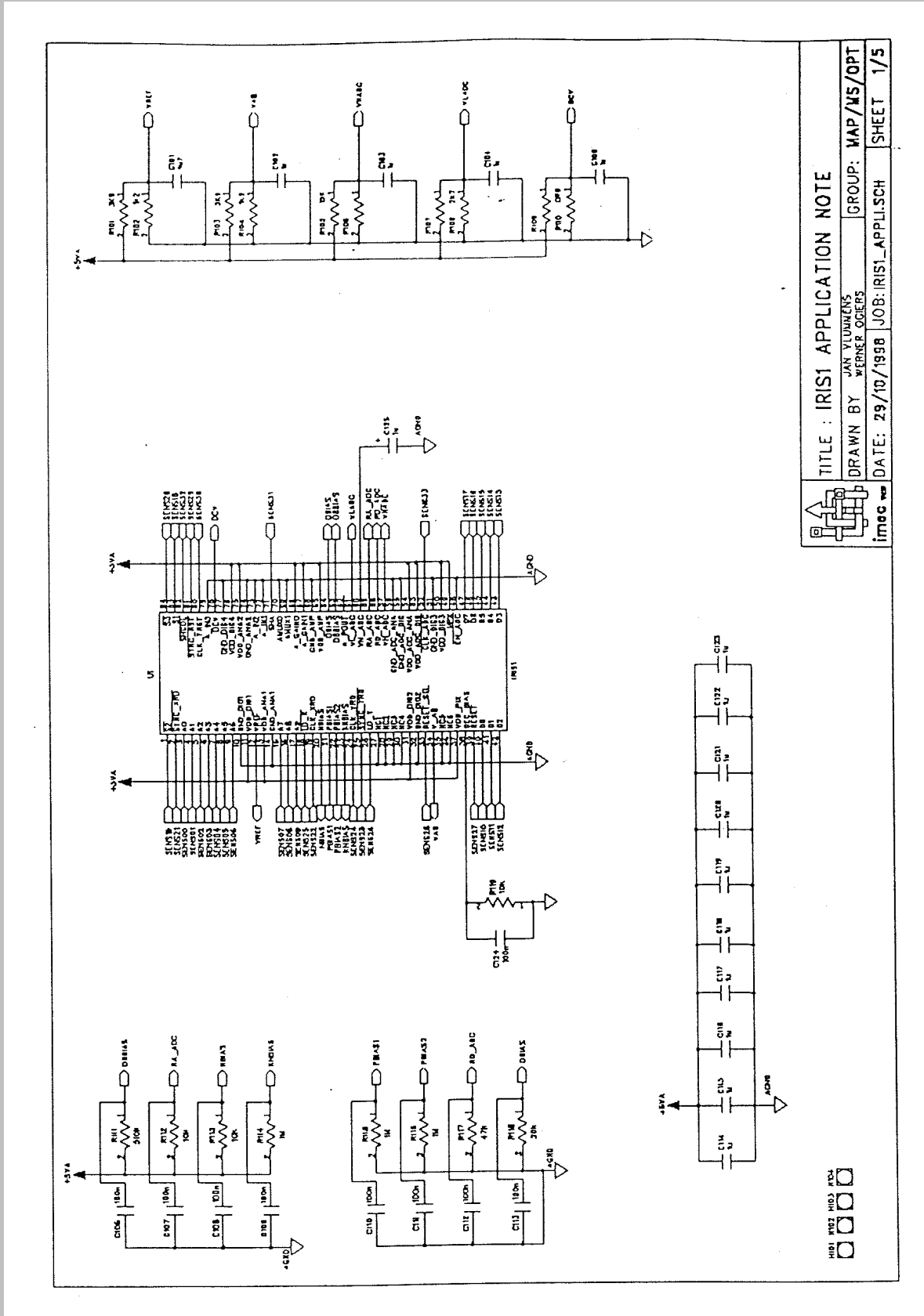

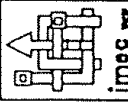
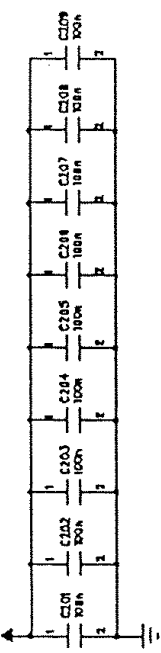
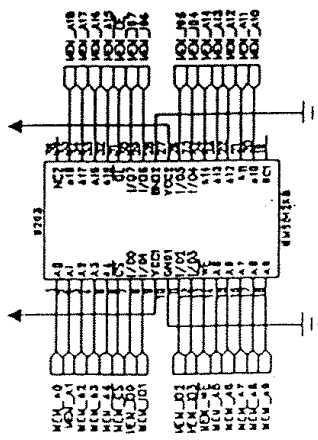
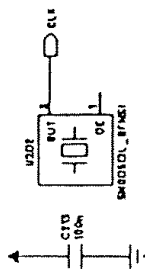
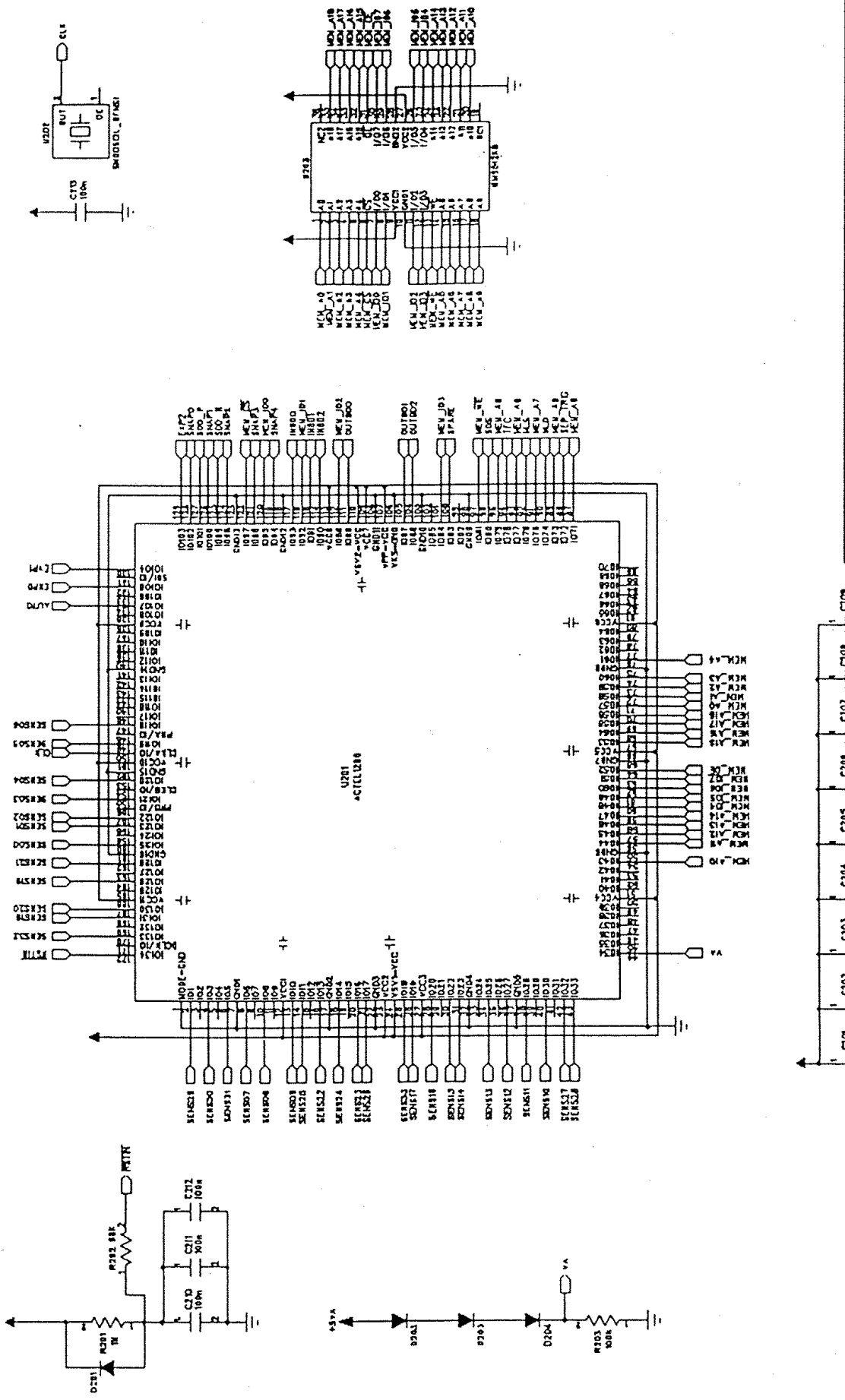

TITLE : IRIS1 APPLICATION NOTE
 DRAWN BY JAN VLIJNERS
 WERNER OGIERNS
 GROUP: MAP/MS/OPT
 DATE: 29/10/1988 JOB: IRIS1_APPLI.SCH SHEET 2/5

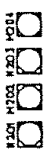

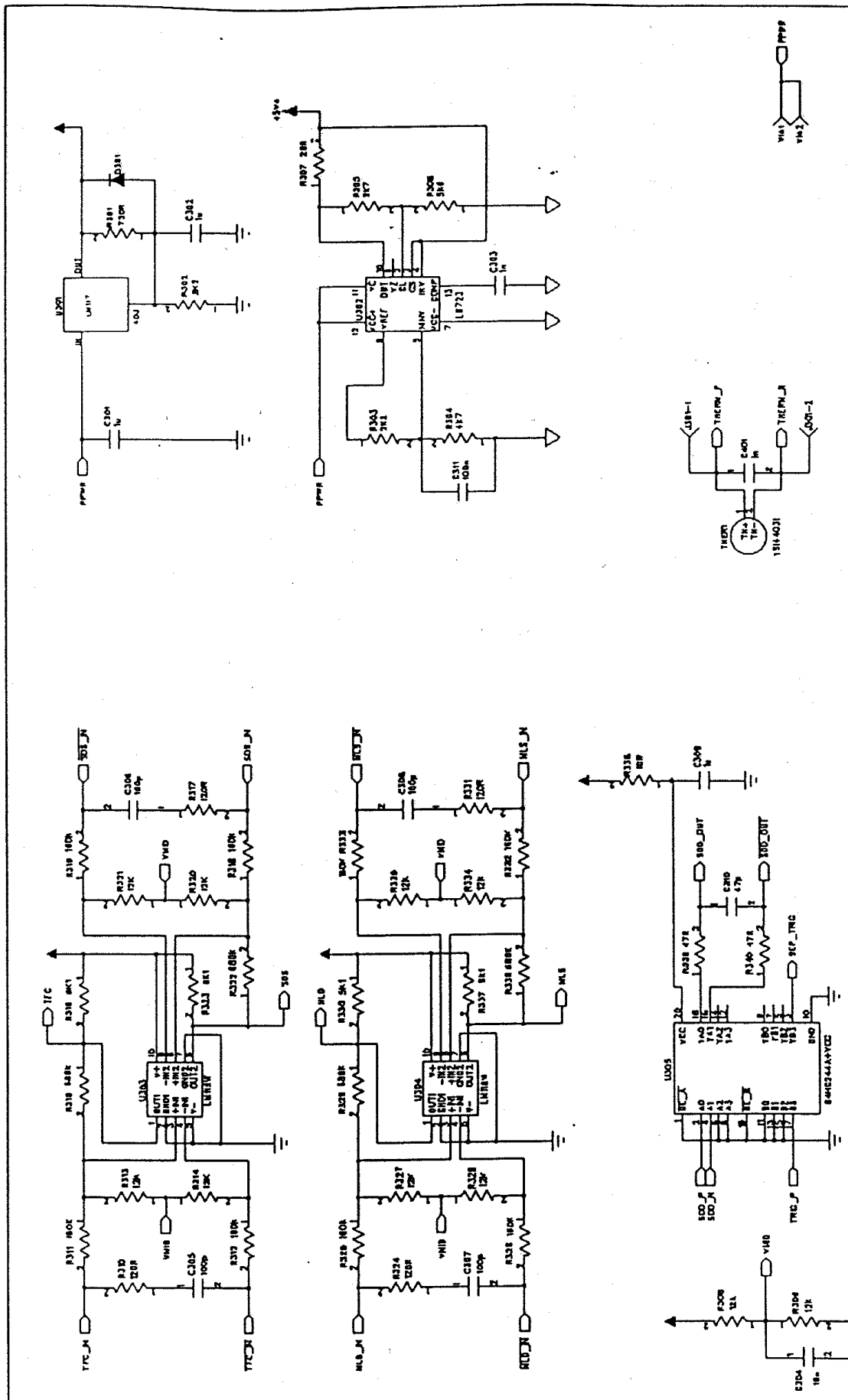

TITLE : IRIS1 APPLICATION NOTE	
DRAWN BY JAN YLUMIENS WERNER OGIER	GROUP: MAP/MS/OPT
DATE: 29/10/1998	JOB: IRIS1_APPLI.SCH
SHEET 3/5	

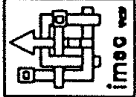

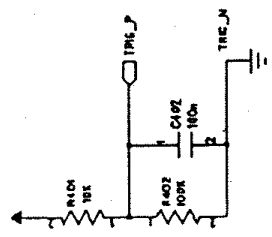
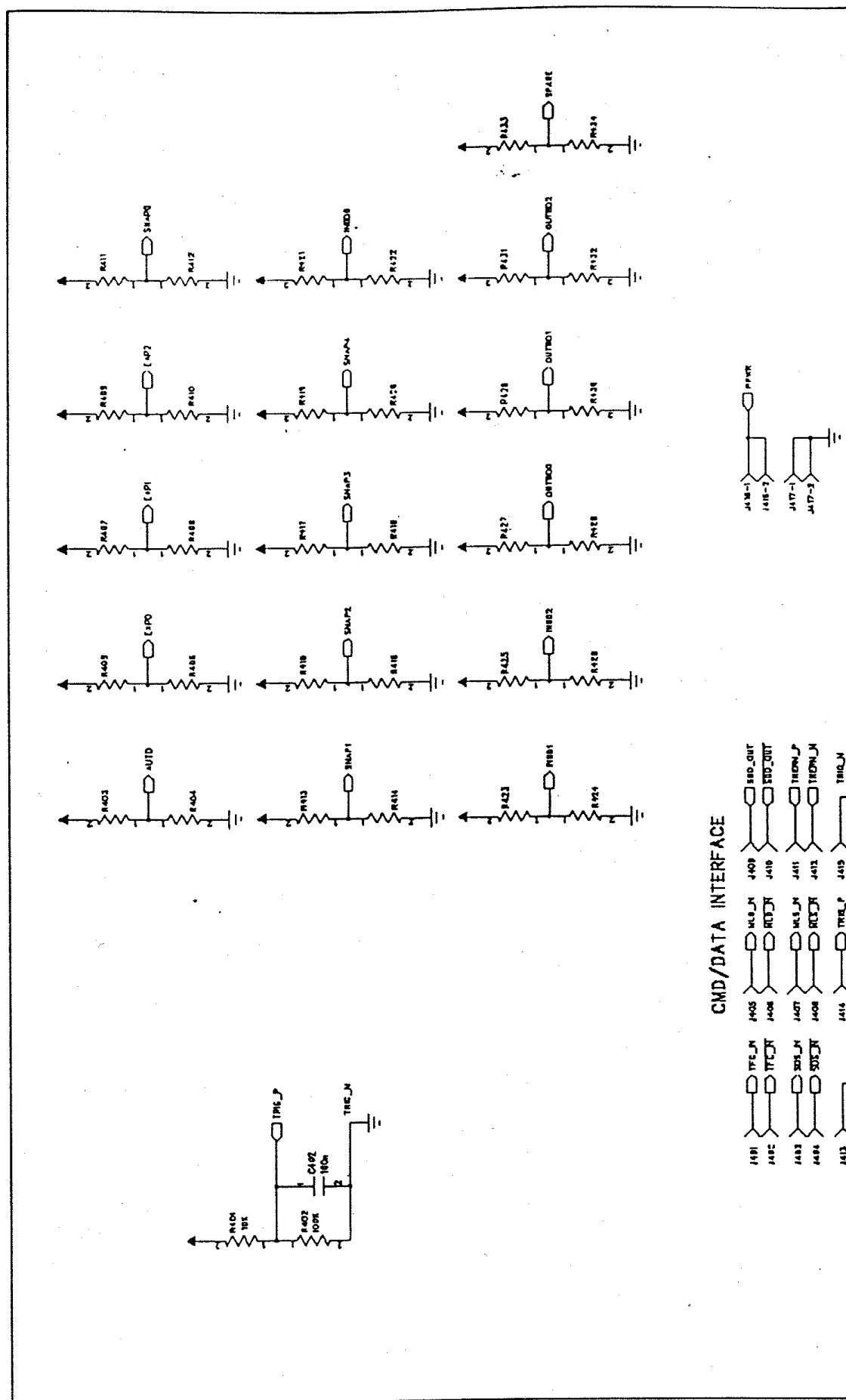

CMD/DATA INTERFACE

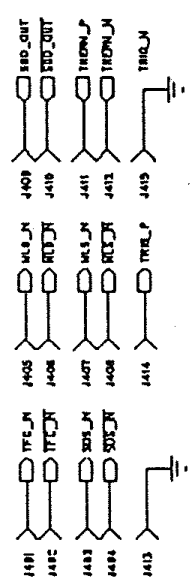

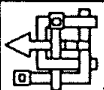
TITLE : IRIS1 APPLICATION NOTE
 DRAWN BY JAN VLUMENS
 WERNER OGIERE
 GROUP: MAP/MS/OPT
 DATE: 29/10/1998 JOB: IRIS1_APPLI.SCH SHEET 4/5

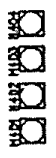

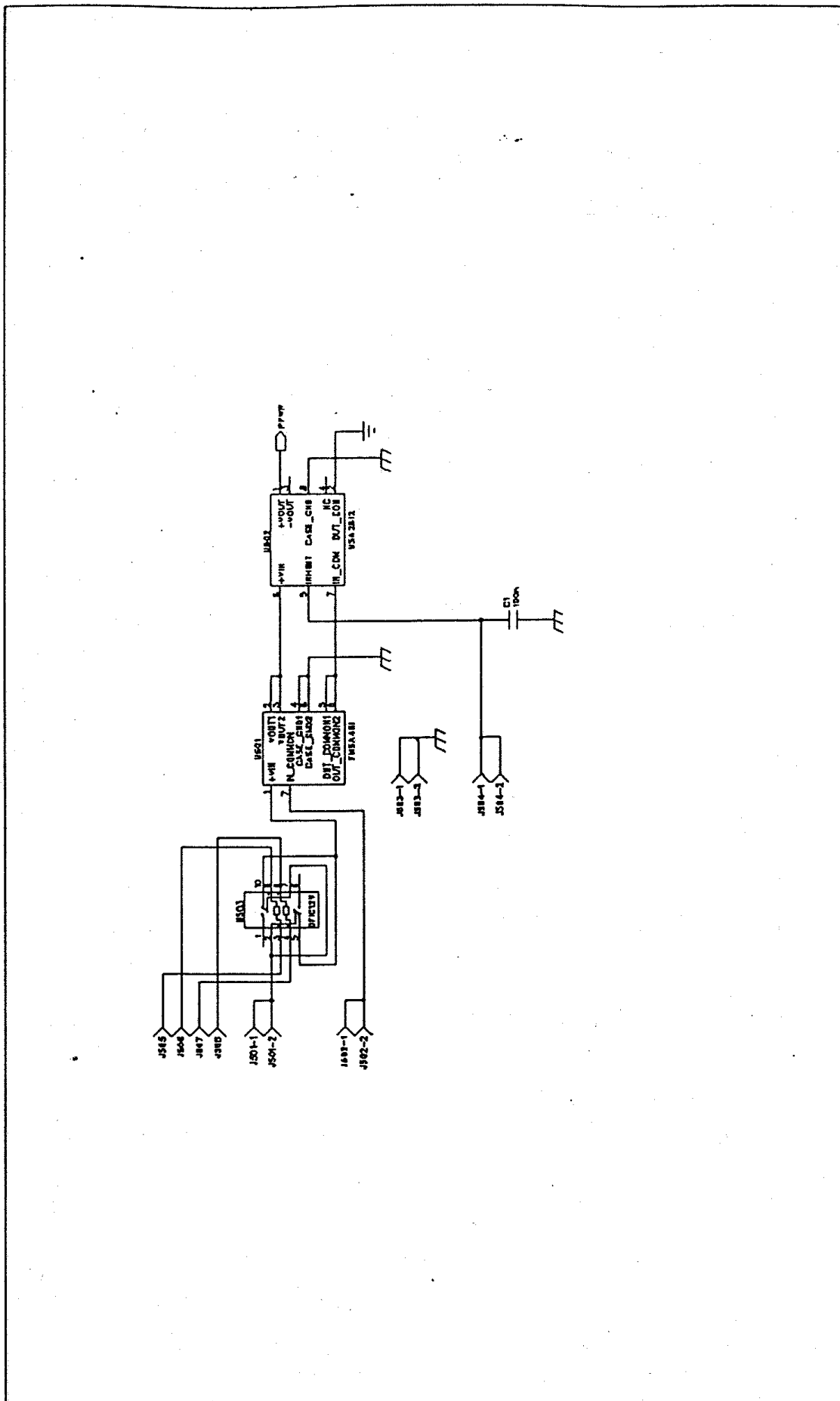

TITLE : IRIS1 APPLICATION NOTE	
DRAWN BY JAN VLUMRENS	GROUP: MAP/MS/OPT
DATE: 29/10/1998	JOB: IRIS1_APPLI.SCH
SHEET 5/5	

