 MEX	<p style="text-align: center;"> MARS EXPRESS OMEGA EXPERIMENT FLIGHT USER MANUAL </p>	Reference : OME-DU-0023-118-IAS Author : M. Berthé Edition : 3 Revision : 0 Rev. date : 15 May 2003 Page : 1
---	--	---

Mars Express
OMEGA experiment
Flight User Manual
V 3.0

	Name	Function	Date	Signature
Prepared by	M. Berthé	Technical Manager	15/05/2003	
Verified by	Y. Langevin	Software Manager		
Approved by	A. Soufflot	Experiment Manager		
Authorised by	J-P. Bibring	Principal Investigator		



**MARS EXPRESS
OMEGA EXPERIMENT
FLIGHT USER MANUAL**

Reference : OME-DU-0023-118-IAS
 Author : M. Berthé
 Edition : 3
 Revision : 0
 Rev. date : 15 May 2003
 Page : 2

Page Issue Record

Date	Edition	chapter	Change
11/06/01	1.5	4.1.1	Typo corrected, Dark sky measurement defined as reference measurement
11/06/01	1.5	4.1	Clarification added about Observation Start and Stop mechanism (via TC only)
11/06/01	1.5	7.4.1	Details added about Limited life items and Cooler operation constraints
11/06/01	1.5	8.3.1.1	Clarifications added to TC(6.2) service
12/09/01	1.5	9.2.2	HK parameters defined and calibration curves added
12/09/01	1.5	9.4.1.1	Initialization TC parameters defined more precisely
12/09/01	1.5	9.4.1.2	Parameter TC parameters defined more precisely
12/09/01	1.5	9.2.3	Event Report EIDs redefined
12/09/01	1.5	4.1.2	Observation program definition updated
12/09/01	1.5	7.3.1	Detailed description of the normal FPCs
12/09/01	1.5	7.3.2	Detailed description of the contingency FPCs
12/09/01	1.5	2.4.1	Software functional description updated and expanded
12/09/01	1.5	2.4.1.4	Compression method explained with more details
12/09/01	1.5	2.4.2	Budget Section included
12/09/01	1.5	4.1.1	Instrument Operational Modes definition updated
12/09/01	1.5	4.3.1	Failure detection strategy clarified
19/09/01	1.5	6.5	Interface description section included
19/09/01	1.5	9.4.1.3	Removal of Macro TC function (not used any more)
18/10/01	2.0	All	Minor updates , issue of Version 2.0
17/12/01	2.1	3.1	Telemetry flow updated
17/12/01	2.1	9.2.6.3	Max length of HS Science packet changed to 4096 Bytes
14/01/02	2.1	9.2	HK report updated
17/04/03	3.0	9.4.1.3	Forced stop of camera TC added
15/05/03	3.0	All	Minor updates after IQAR / DRB review
15/05/03	3.0	7.2	FCP and RCP list from FOP included
15/05/03	3.0	9.2.4	Reference and description of NCR-176 added (Dump format)

	MARS EXPRESS OMEGA EXPERIMENT FLIGHT USER MANUAL	Reference : OME-DU-0023-118-IAS Author : M. Berthé Edition : 3 Revision : 0 Rev. date : 15 May 2003 Page : 4
---	---	---

<i>Acronyms and abbreviations</i>	7
<i>Applicable and Reference documents</i>	9
1) General description	10
1.1) Scientific objectives	10
1.1.1. Mineralogy	10
1.1.2. Polar caps and frosts	12
1.1.3. Atmospheric evolutionary processes	12
1.2) Functional objectives	13
1.3) Design description	13
1.4) Performances	14
1.4.1. Expected performances	14
1.4.2. Expected results	16
2) Instrument configuration	17
2.1) Hierarchical configuration	17
2.2) Physical configuration	19
2.3) Electrical configuration	19
2.4) Software configuration	19
2.4.1) Functional description	19
2.4.1.1 General description	19
2.4.1.2 The software structure and languages	20
2.4.1.3 The interrupt triggered routines	21
2.4.1.4 The poll loop: compression and formatting	23
2.4.1.4 Data compression	24
2.4.2) Budgets	25
2.4.2.1. Power budget	25
2.4.2.2 Telemetry Budget	26
Nominal case : High rate TM operational	27
Contingency mode: High rate TM Not operational	29
3) Detailed description	29
3.1) Digital data interface to the Spacecraft.	29
3.2) Power interface to the Spacecraft.	32
4) Instrument Operations	34
4.1) Overview of operating principles	34
4.1.1. Observation programs	34
4.1.1.1 Mars Observation:	34
4.1.1.2 Stellar calibration:	35
4.1.1.3 Dark Sky calibration	36
4.1.1.4 Simplified Control	36
4.1.1.5 Outgassing	36
4.2 Nominal Operation Plan	38
4.2.1 Ground operation plan	38
4.2.1.1 Full Performance Test	38
4.2.1.2 Limited Performance Test	38
4.2.1.3 GO-NOGO Test	38

	MARS EXPRESS OMEGA EXPERIMENT FLIGHT USER MANUAL	Reference : OME-DU-0023-118-IAS Author : M. Berthé Edition : 3 Revision : 0 Rev. date : 15 May 2003 Page : 5
---	---	---

4.2.1.4 Specific Tests	38
4.2.2 In Flight Operation plan	39
4.3.1) Failure detection	39
4.3.2) Software Update	39
5) Mode description	41
5.2) Mode transition diagram	42
5.3.1) Boot	42
5.3.2) Upload	42
5.3.3) Initialization	43
5.3.4) Pre-observation	43
5.3.5) Observation	43
5.3.6) Outgassing	44
6.1) Power	45
6.2) Mechanical	45
6.3) Thermal	45
The other stages (room temperature and spectrometer temperature) are controlled by the S/C.	46
6.4) Optical	46
6.5) Data	46
6.5.1) RTU Telemetry	46
6.5.2.1. Link start-up:	47
6.5.2.2. Data transmission from Omega to SSMM	47
6.5.2.3 Link closure at end of Omega science acquisition	47
6.5.2.4 Link closure by DMS (transmission error or packet store boundary reached)	47
6.6) Control	48
6.6.1) Pulse Commands	48
6.6.2) RTU Serial Telecommands	49
7) Nominal and contingency operations procedures	50
7.1) Ground test sequence	50
7.2) Flight Control Procedure/ Contingency Recover procedure	50
7.3.2) Contingency Procedures:	52
7.3.2.1 Software Upload: OME_SWUPL	52
7.4) Operational Constraints	55
7.4.1) In flight limitation:	55
7.4.2) On ground test limitation:	55
8) Summary of Telemetry and Telecommands	56
8.1) List of dangerous Commands	56
8.2) Summary of Telemetry and Telecommand packets	57
8.3) Telemetry and telecommand parameters	58
8.3.1) Command Handling	58
8.3.1.1) Telecommand verification	58
8.3.2) Data generation and formatting	60
8.3.2.1) Telemetry generated directly from a TC (solicited TM)	60
8.3.2.2) Event packets	60
8.3.2.3) Housekeeping Report Packets	60
8.3.2.4) Science Report Packets, High Speed Link	60
8.3.2.5) Science Report Packets, RTU Link	60

	MARS EXPRESS OMEGA EXPERIMENT FLIGHT USER MANUAL	Reference : OME-DU-0023-118-IAS Author : M. Berthé Edition : 3 Revision : 0 Rev. date : 15 May 2003 Page : 6
---	---	---

8.4) Summary of software parameters	61
9) Data Operation Handbook	62
9.1) Generic Telemetry Source Packet Structure	62
9.2) Telemetry structure by service types	64
9.2.1) TM Service 1, TC verification reports	64
9.2.1.1) Acceptance Acknowledge success	64
9.2.1.2) Acceptance failure	65
9.2.2) TM Service 3, HK reporting	67
9.2.3) TM Service 5, Event Reporting	73
9.2.3.1) Normal progress report	73
9.2.3.2) Anomalous event report	75
9.2.4) TM Service 6, Memory management	76
9.2.5) TM Service 17, Ping test report	77
9.2.6) TM Service 20, Science reporting	78
9.2.6.1) OMEGA Science Report in RTU channel	78
9.2.6.2) OMEGA Science HS Report is stopped at packet boundary	79
9.2.6.3) OMEGA Science Report via HS link	80
9.3) Generic Telecommand Packet Structure	81
9.4) Telecommand Structure	83
9.4.1) OMEGA private TCs; Service 211	83
9.4.1.1) Initialization TC	83
Configuration TC element: 02 XX XX XX	84
Spectrometer TC element: 05 XX XX XX	85
9.4.1.2) Parameter TC	86
9.4.1.3) Activity TC	91
9.4.1.4) Cooler control TC	94
9.4.2) TC service 3, Enable / Disable HK reporting	96
9.4.2.1) Enable HK reporting	96
9.4.2.2) Disable HK reporting	97
9.4.3) TC service 6, Memory management	98
9.4.3.1) Memory load by absolute address	98
9.4.3.2) Memory dump request by absolute address	99
9.4.4) TC service 9, Accept time update	100
9.4.5) TC service 17, Request connect test response	101
9.4.6) TC service 20, Enable / Disable Science reporting	102
9.4.6.1) Enable Science reporting via RTU channel	102
9.4.6.2) Disable Science reporting via RTU channel	103
9.4.6.3) Enable Science reporting via HS channel	104
9.4.6.4) Disable Science reporting via HS channel	105
9.4.7) TC service v255, Common payload services	106
9.4.7.1) Reset TM output buffer	106
9.4.7.2) Reset SMCS Chip	107
9.4.7.3) Start HS Link	108
9.4.7.4) Reset SMCS and Start HS Link	109



MARS EXPRESS
OMEGA EXPERIMENT
FLIGHT USER MANUAL

Reference : OME-DU-0023-118-IAS
Author : M. Berthé
Edition : 3
Revision : 0
Rev. date : 15 May 2003
Page : 7

Acronyms and abbreviations

ACK	ACKnowledge
AD	Applicable Document
ADC	Analog to Digital Converter
ADSP	Analog Digital Signal Processor
AIV	Assembly, Integration and Verification
APID	Application Process IDentifier.
AU	Astronomical Unit
BCP	BroadCast Pulse
CCD	Charge Coupled Device
CNES	Centre National d'Etudes Spatiales
CPU	Central Processing Unit
CRC	Cyclic Redundancy Code
CUC	CCSDS Unsegmented time Code
DESPA	Département de Recherches Spatiales
DMS	Data Management System.
DN	Digital Number
DSP	Digital Signal Processor
DVD	Digital Video Disk
EGSE	Electrical Ground Support Equipment
EID	Event IDentifier
EM	Electrical Model
ESA	European Space Agency
FCC	(hs link)
FEA	Fore-Optics Electrical Assembly
FIFO	First-In First-Out
FM	Flight Model
FOA	Fore-Optics Optical Assembly
FOV	Field of View
FPT	Full performance Test
HFC	High Frequency Clock
HK	HouseKeeping
HPC	High Power Command
HRD	High Rate Data
HS	High Speed link
H/W	HardWare
IAS	Institut d'Astrophysique Spatiale
ICD	Interface Control Document
IEEE	Institute of Electrical and Electronics Engineers
IFOV	Instantaneous Field of View
IFSI	Istituto di Fisica dello Spazio Interplanetario
IKI	Institut Kosmitcheski Isledovanie
IR	InfraRed
LCL	Latching Current Limiter
LOBT	Local On Board Time
LPT	Limited Performance Test
MEC	Main Electronics Control unit (inside the OMEM)
MEI	Main Electronics Interface unit (inside the OMEM)
MEP	Main Electronics Power supply unit (inside the OMEM)



MARS EXPRESS
OMEGA EXPERIMENT
FLIGHT USER MANUAL

Reference : OME-DU-0023-118-IAS
Author : M. Berthé
Edition : 3
Revision : 0
Rev. date : 15 May 2003
Page : 8

MEX	Mars Express
MLC	Memory Load Command
OBCP	On Board Control Procedure.
OMEGA	Observatoire pour la Minéralogie, l'Eau, les Glaces et l'Activité
OMEGA-EGSE	OMEGA Electrical Ground Support Equipment
OMEC	OMEGA Camera Unit
OMEM	OMEGA Main Electronics
OMEH	OMEGA OMEC to OMEM interconnecting Harness
PA/QA	Product Assurance/Quality Assurance
PAD	Part Approval Document
PDS	Planetary Data System
PI	Principal Investigator
PID	Payload Interface Document
PID (in data)	Process IDentifier
PROM	Programmable Read-Only Memory
PUS	Packet Utilization Standard
RD	Reference Document
RFD	Ready For Data
ROM	Read-Only Memory
RTU	Remote Terminal Unit (TM/TC controller)
S/C	SpaceCraft
SCET	SpaceCraft Elapsed Time
SDT	Serial Digital Telemetry
SEA	Spectrometer Electronics Assembly
SEG	Spectrometer Electronics manaGement
SEP	Spectrometer Electrical Power
SES	SWIR Electronics System
SFOV	Scientific Field of View
SGIDB	Space Ground Interface Control Document
SID	Structure IDentifier
SKA	SWIR cryogenic Assembly
SKC	SWIR cooling system control
SKK	SWIR cooling system
SNR	Signal over Noise Ratio
SMCS	IEEE control chip
SOA	SWIR Optical Assembly
SSMM	Solid State Mass Memory.
STM	Structural and Thermal Model
SWIR	Short Wavelength InfraRed channel
TBC	To Be Confirmed
TBD	To Be Defined
TC	TeleCommand
TM	TeleMetry
TSY	Time Synchronization pulse
UART	Universal Asynchronous Receiver Transmitter
UFOV	Unobstructed Field of View
VEA	VNIR Electrical Assembly
VOA	VNIR Optical Assembly
VNIR	Visible and Near InfraRed channel
WBS	Work Breakdown Structure
WRT	With Respect To

	<p>MARS EXPRESS OMEGA EXPERIMENT FLIGHT USER MANUAL</p>	<p>Reference : OME-DU-0023-118-IAS Author : M. Berthé Edition : 3 Revision : 0 Rev. date : 15 May 2003 Page : 9</p>
---	---	--

Applicable and Reference documents

Applicable documents:

AD 1: Mars express SGIDB , ME-ESC-IF-5001, Issue 2.0, dated 20 December 1999

Reference documents

RD 1: Projet Mars 94, experience Omega, Document Général des Interfaces, Section télécommandes, Edition 6, Rev. 0

RD 2: Control structure for Omega experiment; Draft 2, 01/12/00, YL

RD 3: Projet Mars 94, experience Omega, Document Général des Interfaces, Section télémesures, Edition 4, Rev. 1

RD 4: OMEGA PID B (Payload Interface Document), OME-CI-0022-003-IAS, last edition

	MARS EXPRESS OMEGA EXPERIMENT FLIGHT USER MANUAL	Reference : OME-DU-0023-118-IAS Author : M. Berthé Edition : 3 Revision : 0 Rev. date : 15 May 2003 Page : 10
---	---	--

1) General description

1.1) Scientific objectives

OMEGA is issued from an international Scientific and Technical co-operation, between France, Italy and Russia, involving the following Institutions: **IAS** (Institut d'Astrophysique Spatiale, Orsay, France), **DESPA** (Département de Recherches Spatiales, Observatoire de Paris/Meudon, France), **IFSI** (Istituto di Fisica Spaziale, Roma, Italia) and **IKI** (Institute for Space Research, Moscow, Russia). Both the PI and the EM are from IAS.

OMEGA is a visible and near infrared mapping spectrometer that fulfils the overall science objectives assigned to the IRMS instrument in the Mars Express Orbiter Model Payload (ESA/SCI(97)3). This instrument has been already developed in the framework of the Mars'96 mission, for which a spare unit has been fully integrated and calibrated prior to its delivery. After being recovered by IAS, its full functionality and quality have been verified by re-calibration, this unit has been refurbished and tested with respect to the Mars Express interfaces and constraints.

Combining imagery and spectrometry, OMEGA is designed to provide the mineralogical and molecular composition of the surface and atmosphere of Mars through the spectral analysis of the re-diffused solar light and surface thermal emission. OMEGA will provide a global coverage at medium resolution (1 to 5 km) of the entire surface of Mars from altitudes 1000 to 4000 km, and snapshots of selected areas, amounting to at least a few percents of the surface, with a resolution of a few hundreds meters when observed close to periapsis (300 km altitude). More specifically, with the above mentioned spatial resolution, OMEGA should allow:

- to characterise the composition of surface materials, discriminating between the various classes of silicates, hydrated minerals, oxides and carbonates, organic frosts and ices;
- to study the time and space distribution of atmospheric CO₂, CO and H₂O;
- to identify the aerosols and dust particles in the atmosphere, and observe their time and space distributions;
- to monitor the surface dust transportation processes.

OMEGA will therefore address major questions associated to internal structure, geologic and chemical evolution, past activity and present surface variegation. It will greatly contribute to the understanding of the evolution of Mars from geological time scales to seasonal variations. It will in particular give unique clues for understanding the H₂O and CO₂ cycles over the Martian life. It will play a major role in identifying areas of interest for the future Martian in situ explorations.

1.1.1. Mineralogy

OMEGA will map the surface of Mars in order to identify the minerals of the major geological units. The goal is to monitor the past and present evolution of Mars induced by internal activity, meteoritic impacts and the interaction with the atmosphere.

	MARS EXPRESS OMEGA EXPERIMENT FLIGHT USER MANUAL	Reference : OME-DU-0023-118-IAS Author : M. Berthé Edition : 3 Revision : 0 Rev. date : 15 May 2003 Page : 11
---	---	--

A global mapping of Mars will be achieved with a resolution of a few kilometres. Indeed, the Viking and MGS1 orbiter images indicate strong albedo variations down to sub-kilometre scales. ISM/Phobos spectral images in the near IR also exhibit large compositional variations at kilometre scales. Moreover, this investigation demonstrated that although large amounts of transported soil with uniform properties cover parts of the surface, all geological units exhibit part of their uncovered bedrock at these scales. Therefore, OMEGA should identify the diversity of the global Martian surface, inferring compositional variations directly related to planetary evolution.

In addition, OMEGA will benefit from observations close to periapsis to significantly improve the resolution for at least a few percents of the Martian surface. This should in particular permit:

- to increase the sensitivity for detecting constituents with restricted geographical extension. For example, the present failure of detection of carbonates might be directly linked to limited instrumental resolution. High resolution snapshots of areas more likely to have accumulated sedimentary carbonates might lead to a positive detection of fundamental value;
- to map mineralogical boundaries between geological units, in particular recent plains and older regions with high density of impact craters, thus helping understanding the hemispheric Martian asymmetry;
- to identify the composition of deposits and observe possible gradients in the hydration minerals near features associated with fossil water flows;
- to monitor features associated with wind transportation.

For a closest approach of 300 km, the OMEGA field of view of 4.1 arc-minutes corresponds to 360 m. This can be considered adequate for high resolution imaging of selected areas of interest. The elliptical orbit with apoapsis higher than 4000 km will also allow OMEGA to acquire a global mapping of the surface at resolutions 2 to 5 km. As for the spectral range and spectral resolution, OMEGA operating from 0.36 to 5.2 μm with 352 contiguous spectels will identify the major classes of silicates and other important minerals (such as carbonates), oxides and hydrates, as well as frosts. Moreover, OMEGA will be capable of monitoring the content of OH radicals within the surface soil and rocks, so as to identify possible genetic relationships of hydrated minerals with major structural units such as volcanoes or canyons. In addition, the presence of fluidised ejecta around impact craters is likely to indicate that the underlying bedrock contains ice mixed with rocks. It is then plausible that ejecta experienced hydration. The spectral features of hydrated minerals (clays) are readily observable in the near IR.

Alteration processes transformed Martian mafic rocks into ferric-bearing minerals. In order to understand when this process took place (via volcanic activity, interaction with the atmosphere of flooding water), it is essential to relate these minerals with geological structures. OMEGA will detect these altered minerals through their signatures between 0.5 and 0.8 μm .

It is plausible that the CO₂ Martian reservoir is dominantly in the form of carbonates. The detection and localisation of these minerals would be of key importance for understanding the past activity of the planet: OMEGA should unambiguously detect them, even at very low concentrations, through their absorption features between 3.6 and 4.0 μm .

	MARS EXPRESS OMEGA EXPERIMENT FLIGHT USER MANUAL	Reference : OME-DU-0023-118-IAS Author : M. Berthé Edition : 3 Revision : 0 Rev. date : 15 May 2003 Page : 12
---	---	--

1.1.2. Polar caps and frosts

OMEGA will determine the spatial evolution of the two polar caps, by the observation of both CO₂ and H₂O. It will enable to monitor the cycle of sublimation/condensation, from one pole to the other, and to discriminate between the contributions of the two major atmospheric constituents as a function of time and location. OMEGA will also identify dust within the polar ices; its composition indicates where it originated from, thus allowing to follow the transportation processes.

At lower latitudes, the condensation of frost will be mapped over time, for both CO₂ and H₂O. In addition, we will try to detect minor species containing either carbon or nitrogen: no such molecules have been observed yet, and their discovery would be of major interest for the understanding of the extraterrestrial chemical evolution.

If permafrost layers do exist, they may appear at the very surface in a few regions. OMEGA would then easily detect such icy-rich rocky sites. From the identification of the borders of the underlying permafrost layers, one should be able to evaluate the global distribution of ice within the Martian crust. It is a major goal to try to identify the sites and phases where most of the water resides, in particular when searching for the most favorable sites for a possible past organic activity, and assessing water resources for future exploration.

1.1.3. Atmospheric evolutionary processes

The OMEGA instrument will be well suited for monitoring some of the parameters of the Martian atmosphere (total pressure, column densities of the minor constituents H₂O and CO, content of aerosols, and, in some cases, vertical temperature distribution) which all play a key role in the Martian meteorology. The ISM/Phobos imaging spectrometer, which mapped part of the Martian surface in February-March 1989, has demonstrated the ability of infrared spectroscopy, even at low (20 km) spectral sampling, to retrieve precisely the altimetry of Mars (100 m vertical resolution). The observations of CO₂ bands with OMEGA will give, as from ISM/Phobos, a measurement of the ground pressure. As the altimetry on Mars will be better known, at time of Mars Express observations, after the laser-altimeter measurements of MGS1, Omega will study local pressure variations, as induced by baroclinic wave pattern at mid-latitudes by passing over the same regions at different times. Expected variations of a few percent of the atmospheric pressure will be easily measured with OMEGA (design goal is accuracy of 1%), in the absence of global dust storms.

OMEGA will monitor the CO and H₂O partial pressure for each resolved pixel. The space distribution of these minor constituents is still of field of great interest, since the ISM/Phobos discoveries of unexpected variations of their mixing ratios from volcano areas and surrounding plains.

Another important atmospheric parameter is the determination of the aerosol content. It plays a key role in the general circulation of the planet, as the Martian dust modifies the radiative properties of the atmosphere through its heating and cooling rates. As the dust content of the Martian atmosphere shows very strong variations, both on a local scale and over a seasonal cycle, its permanent monitoring is as necessary as the knowledge of the local thermal profile. The analysis of the ISM data has shown that the aerosol abundance can be retrieved from the slope of the reflected component of the spectrum. The same information will be derived by OMEGA over the whole Martian disk. Moreover, OMEGA will be able to

	MARS EXPRESS OMEGA EXPERIMENT FLIGHT USER MANUAL	Reference : OME-DU-0023-118-IAS Author : M. Berthé Edition : 3 Revision : 0 Rev. date : 15 May 2003 Page : 13
---	---	--

identify the aerosols through their composition (silicate-rich and/or icy-rich particles), assess their distribution with altitude and time, in addition to their optical properties. In particular, OMEGA will be capable of correlating these measurements to surface and climatic seasonal properties, towards an integrated (surface, atmosphere, aerosols) data base of unique meteorological value.

1.2) Functional objectives

OMEGA will map the Martian surface with an IFOV of 1.2 mrad (4.1 arcminutes), and acquire for each resolved pixel the spectrum from 0.36 to 5.2 micrometers in 352 contiguous spectral channels (spectels).

The optical part consists in two co-aligned units, each including a telescope: a Visible Channel (VNIR) analyses the light from 0.36 to 1.07 μm , using as a detector a bi-dimensional CCD matrix in a pushbroom mode: 96 spectral lines of 128 columns, imaging at once a crosstrack line of 128 pixels large at the surface of Mars; a Near Infrared Channel, named SWIR (Short Wavelength IR Channel) disperses the light through two spectrometers from 0.93 to 2.7 μm and 2.6 to 5.2 μm , onto two linear InSb arrays (whiskbroom mode) cooled down 70K, each with a dedicated cryocooler. A scanning mirror in front of the SWIR telescope permits to acquire crosstrack swaths of 16 up to 128 pixels width, for a maximum FOV of 8.8°, thus matching the VNIR FOV. SNR of \bullet 100 over the entire spectral range, for IR integration times of 5 ms per pixel, is the specification. Derived from the ISM/Phobos previous investigation, and confirmed with the actual OMEGA calibration, this sensitivity level is required and sufficient to identify through their absorption features all major and minor mineral and atmospheric Martian constituents.

The OMEGA main electronics, in addition to powering and controlling the instrument, acquires and compresses all scientific data on line. A typical OMEGA observation sequence leads to a data volume of 128 Mbits acquired during 6 to 20 min. The mapped units, depending from the altitude of operation along the orbit, will range from narrow strips 6 km wide and 2000 km long at high (sub-kilometer) resolution, to extended areas 500x3000 km^2 at spatial sampling 4 to 5 km when imaged from altitudes 3000 to 4000 km.

Thus, the optimal operation modes of OMEGA require the orbit to be elliptic, with a periapsis of the order of 300 km and an apoapsis higher than 4000 km, the actual orbital parameters being the driver to achieve the spatial resolution. The S/C pointing stability should be in agreement with the specified IFOV and integration times of 1.2 mrad and 5 ms respectively to avoid unrestituted jitters. Another major issue is the capability for the OMEGA spectrometers to be cooled to 190K or less thanks to the radiative screen provided by the Mars Express S/C.

1.3) Design description

OMEGA is a mapping spectrometer working both in the visible and near infrared spectral ranges. It is made of two grating spectrographs, one working in the 0.35 to 1 μm visible and near infrared range (VNIR channel), the other in the 1 to 5.2 μm short wavelength infrared range (SWIR channel).

The VNIR channel uses a bi-dimensional CCD THX7863 Thomson detector. The spectrum of a given point of the observed target is formed along a column of the array while spatial resolution along the spectrograph slit is obtained along the lines. The motion of the satellite gives the second spatial dimension itself, the spectrograph slit being oriented perpendicularly to the spacecraft track. In such a case the "elementary exposure" provides the full spectra of every spatial pixel along the slit. The displacement of

	MARS EXPRESS OMEGA EXPERIMENT FLIGHT USER MANUAL	Reference : OME-DU-0023-118-IAS Author : M. Berthé Edition : 3 Revision : 0 Rev. date : 15 May 2003 Page : 14
---	---	--

the spacecraft with respect to the target surface during the "elementary exposure time" must be comparable to (or smaller than) the expected spatial resolution, corresponding to the pixel size.

The SWIR channel is equipped with two InSb linear arrays of 128 elements each, cooled down to 70K approximately and multiplexed by a charge transfer device. The spectrum of a given point of the observed target is formed on the linear detectors array. The spatial images are obtained sequentially by combining the movement of a scanning mirror in front of the instrument and the spacecraft displacement. The typical integration time, defined by the movement of the satellite relative to the ground and the spatial resolution expected, is 5 msec.

1.4) Performances

The capabilities of OMEGA can be summarized as:

- imaging capability: 128 contiguous IFOV of 1.2 mrad each, corresponding to < 500 m at periapsis;
- spectral capability: 352 contiguous spectral channel to acquire the entire spectrum from 0.36 to 5.2 μm for each resolved pixel;
- photometric capability: SNR > 100 over the full spectral range, allowing the identification of percent absorptions and thermal variations.

1.4.1. Expected performances

The scientific performances of the OMEGA flight model will be deduced from a thorough final calibration process, the main characteristics having been determined during the calibration of the Mars'96 FSM and preliminary controlled during optical tests. The calibration facility is constituted of one high resolution grating monochromator for spectral calibration and a blackbody (with temperature stabilized within a degree, in the range 50-1200 °C) imaged as an extended source through a collimator for photometric calibration, one high temperature black body ruban imaged through subpixel size pinholes for geometric calibration: IFOV and FOV determinations for all (visible and IR) channels, and co-alignment of the three channels (the two IR spectrometers and the visible spectrometer), and minerals with known composition for sensitivity measurements.

The central position of each spectel has been determined with an accuracy of 0.1 nm. The spectral width of each spectel has been measured by step by step exploration of the wavelength range. It is fully consistent with the ray tracing estimates, and illustrated in the following figure for three contiguous spectels at wavelengths 1.259, 1.273 and 1.287 μm : the spacing between them is 14.0 nm, exactly as nominal, while their half-widths are very close to 14 nm. Thus, the spectral sampling of OMEGA is optimal.

The looking direction of the two IR spectrometers are identical, and separated from that of the visible channel by less than one pixel in the cross scan direction. It has been measured with a very high accuracy (better than 1/5 pixel) so that the spectral cubes can be resampled to provide complete spectral information on a given region. Flight calibrations using point sources (Mars during cruise phase, Jupiter, bright M type stars) could be performed to check the evolution of this alignment after launch, during cruise and orbital operations.

	MARS EXPRESS OMEGA EXPERIMENT FLIGHT USER MANUAL	Reference : OME-DU-0023-118-IAS Author : M. Berthé Edition : 3 Revision : 0 Rev. date : 15 May 2003 Page : 15
---	---	--

The photometric performances were derived by measuring the instrument response during stepwise heating of the blackbody temperature from ambient to 1200 C by steps of 50 C. A cold blackbody was observed at temperatures from the ambient to liquid nitrogen to evaluate the thermal contribution of the mirrors and window during the calibration process, and to assess the OMEGA sensitivity for measuring the Martian surface temperature at each resolved pixel. At each thermal step, the 3 integration times of the IR channel (5, 10 and 20 msec) and of the VNIR channel (50 msec, 100 msec, and 200 msec) were implemented. By combining results obtained with different integration times, over non-saturated spectral domains, at successive temperature steps, we have also determined with a very high accuracy the linearity of the instrument. It is better than 1% as long as the signal does not get closer than 200 DN from saturation (> 3500 DN).

With these measurements, we have been able to estimate the global response of OMEGA imaging Mars, with its thermal emission (for temperatures from 200 to 290 K) superimposed on the diffused sunlight. Fig. 1.3.2 illustrates the foreseen SNR with the following assumptions:

- albedo 13% (dark regions)
- phase angle 0
- distance to the Sun 1.5 AU
- temperature 260 K (consistent with the low phase angle)
- 5 msec integration time for the IR channels, 100 msec integration time for the VNIR channels
- 90% atmospheric transmission (optimistic for the short wavelengths, but pessimistic for the long wavelengths)

The SNR (thick solid line) is over 100 for most of the wavelength range. It is to be noted that the thermal contribution dominates for dark terrain at wavelengths larger than 4 μm , i.e. over more than 50 channels. Temperature variations should be measured with an accuracy of 0.2 K in the temperature range 220 K - 300 K by integrating over the long wavelength channels. The read noise and electronic noise dominate, but the performances are only a factor of 2 lower than that derived from the photon noise limit. The SNR for a bright region (albedo 40%) will be 2.5 times larger in the region dominated by diffused sunlight (dashed curve), with most of the wavelength range above 200 in terms of SNR. The results from the ISM imaging spectrometer on the Phobos mission demonstrate that this increased SNR is quite relevant as spectral variations in the bright regions, which correspond to widespread dust deposits, are much smaller than that observed in the dark regions, where the local material can be directly observed.

For observations in the global mapping mode, from altitudes of several thousand km, the low drift velocities will make possible the use of longer integration times (10 or 20 msec for the IR, 200 msec for the visible) with corresponding increases in SNR. Summing successive scans, with a gain of 1.4 or 2 depending on the summing mode can make additional improvements. These high SNR modes will be implemented at large phase angles (polar caps, terminator), when saturation is not a problem. For the most difficult observing conditions (dark areas in high latitude regions), we plan to implement 2 x 2 spatial summing to improve the SNR by another factor of 2. It should be noted that there are very few low albedo regions at high latitudes, which are dominated by polar caps, wind blown bright deposits and high albedo frosts in winter.

	<p style="text-align: center;">MARS EXPRESS OMEGA EXPERIMENT FLIGHT USER MANUAL</p>	<p>Reference : OME-DU-0023-118-IAS Author : M. Berthé Edition : 3 Revision : 0 Rev. date : 15 May 2003 Page : 16</p>
---	---	---

1.4.2. Expected results

The high sensitivity of OMEGA (SNR > 100) and its high spectral sampling capabilities (7 nm in the visible, 14 nm up to 2.7 μm and 21 till 5.2 μm) should allow, *on each resolved pixel*, to detect unambiguously the atmospheric major and minor constituent, to determine the composition of the surface material and their water content, to identify the aerosols. As examples, the carbonates, if present at concentration of a few percents, should be readily detected; at the same spatial scale, the surface temperature of Mars will be mapped with accuracy better than a degree.

Such performances will undoubtedly lead to an unprecedented harvest of results in a large variety of Martian and planetary science fields such as: geology, tectonic and chemical planetary evolution, climatology and meteorology, atmospheric processes, exobiology.

	<p>MARS EXPRESS OMEGA EXPERIMENT FLIGHT USER MANUAL</p>	<p>Reference : OME-DU-0023-118-IAS Author : M. Berthé Edition : 3 Revision : 0 Rev. date : 15 May 2003 Page : 17</p>
---	---	---

2) Instrument configuration

2.1) Hierarchical configuration

The instrument is made of three parts:

- one Camera unit (OMEGA-CAMERA or OMEC) with the VNIR and SWIR spectrographs and associated electrical devices and one electronics assembly for the control of the camera,
- one Main Electronics (OMEGA-ME or OMEM) module mainly in charge of the general management of the instrument,
- a harness between OMEC and OMEM, named OMEH

The VNIR channel of the Camera is based on a push-broom system with one bi-dimensional silicon array and a telescope covering an 8.8° total field of view, which is defined by a slit, placed in the focal plane of the telescope. The slit by itself is imaged on the CCD, by means of a concave holographic grating.

The SWIR channel of the Camera uses one common telescope associated to one slit and followed by one collimator. The output beam is splinted into two parts to cover the 0.93-2.7 μm band for the short wavelength and the 2.6-5.2 μm for the long wavelength. The use of linear arrays as detectors leads to a whiskbroom concept. One point of the slit is imaged spectrally on the detectors and a scanning mirror gives the 8.8° cross-track field of view. Each spectrometer is a grating one. It includes a field mirror, and a refractive refocusing system that give a large aperture on the detection block (f/1.6).

The VNIR and SWIR spectrographs are integrated together and cooled down to a temperature lower than 200K by a direct connection to a cold radiator. They are mounted on a base plate that also receives dedicated electronic and electro-mechanical peripherals. An electronic module named SEA (Spectrometer Electronics Assembly) insures the control of the camera. The Main Electronics module is linked to the camera by means of a cable which length is of the order of 1 m.

The general block-diagram is shown in the following page.



MARS EXPRESS
OMEGA EXPERIMENT
FLIGHT USER MANUAL

Reference : OME-DU-0023-118-IAS
Author : M. Berthé
Edition : 3
Revision : 0
Rev. date : 15 May 2003
Page : 18

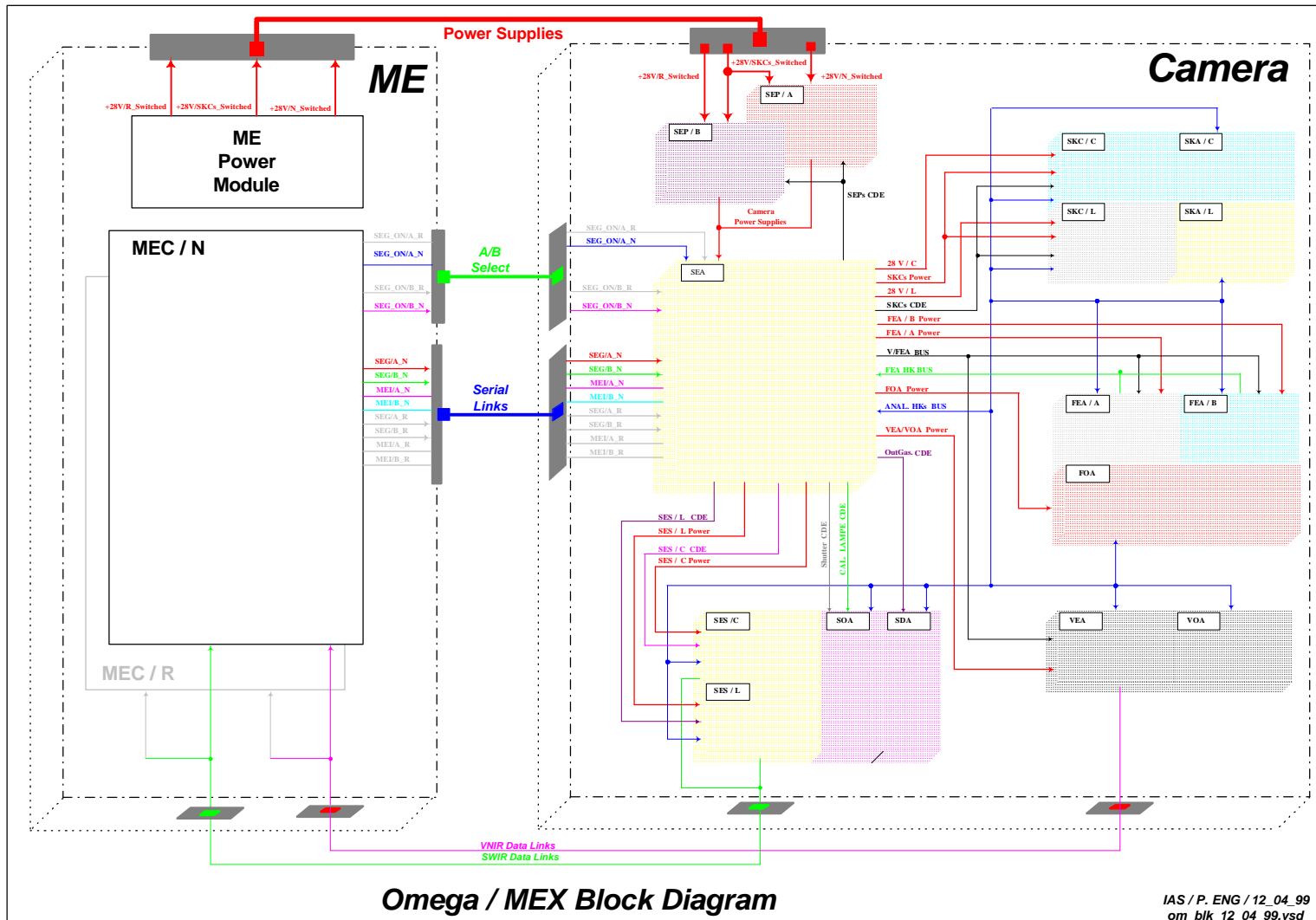

 MEX	MARS EXPRESS OMEGA EXPERIMENT FLIGHT USER MANUAL	Reference : OME-DU-0023-118-IAS Author : M. Berthé Edition : 3 Revision : 0 Rev. date : 15 May 2003 Page : 19
---	---	--

2.2) Physical configuration

The two main units, OMEC (Camera) and OMEM (Main Electronics) are independent. They have a size and weight of 599x325x360 mm, 23.8 kg and 180x290x150 mm, 5.1 kg respectively.

2.3) Electrical configuration

The electronic system is shared between two parts (see block-diagram)

- one main electronics module OMEM that gathers several specialized equipments: central Control system MEC made of one interfaces management system MEI; and one control and data processing unit ME-CDPU; power supply system MEP

- one ensemble (OMEC) which groups the electronic modules SEP (camera low voltage power supplies), SEA (power switching, management and control of the camera sub-systems), SKC (coolers drivers), SES (SDA IR detectors signal acquisition and processing), VEA (VOA visible channel control and management) and FEA (FOA scanning mechanism control).

2.4) Software configuration

2.4.1) Functional description

2.4.1.1 General description

The OMEGA experiment was initially scheduled for the MARS 96 mission, which failed at launch in November 1996. OMEGA was reselected for the Mars Express mission of ESA, to be launched in June 2003. It consists in two main units: a camera unit and a main electronics module.

The Mars'96 spare model of the camera unit has been used as such with some improvements mainly decided to withstand the Mars Express interfaces and mechanical constraints, e.g. the baseplate, the scanner, the visible channel and the power sub-system. The camera consists in two spectrometer, a visible spectrometer (channel V) and an infrared spectrometer, the latter operating in two orders, at short wavelength (channel S) and long wavelength (channel L). The visible spectrometer operates in the pushbroom mode. The infrared spectrometer operates in a whiskbroom mode, with a pointing and scanning mirror integrated into its foreoptics. All the subsystems on the spectrometer unit are controlled by a microcontroller, which communicates with the main electronics via a bidirectional serial line.

The software for the microcontroller (written in support specific C) has not been modified for Mars Express. The main electronics module (OMEM) of the OMEGA experiment has been completely redesigned for the Mars Express mission. One single processor instead of 3, a DSP 21020 which runs at 20 MHz provides the required computing power. A new compression option, using wavelet transforms, has been developed and implemented. Notwithstanding these changes, a major constraint of the development of software for the new OMEGA ME has been to maintain the maximum commonality

	MARS EXPRESS OMEGA EXPERIMENT FLIGHT USER MANUAL	Reference : OME-DU-0023-118-IAS Author : M. Berthé Edition : 3 Revision : 0 Rev. date : 15 May 2003 Page : 20
---	---	--

with the previous version. In particular, the modifications to the structure of telecommands has been kept to a minimum.

The functions of the software within the main electronics of OMEGA on-board Mars Express are:

- the reception and interpretation of the telecommands and time tags from the spacecraft
- the switching on and control of the different subsystems of the experiment both before observations (a period of 2 to 3 hours required for cooling the detectors) and during observations
- the acquisition of the data from the 3 channels (V, S, L) and its storage into DRAM
- the data compression (if requested by the TC) and formatting into an output stream of ESA compatible TM packets.
- the sending of each TM packet to the spacecraft

The priorities of these tasks are in the following order:

1. interface with the spacecraft: reception of telecommands, time tags and TM packet requests, high speed link transfers of data packets.
2. interface with the spectrometer: reception of messages through the serial line
3. Acquisition of data from the three channels
4. Error management
5. Scheduling
6. Compression (if requested) and formatting of data into TM packets

Task 6 is by far the most demanding in terms of computing time. It will constitute the background task for all activities. Its behavior is controlled by flags set by tasks 1, 2 and 3. It processes one of two rectangles of data accumulated by previous acquisitions. In the mean time, further acquisitions accumulate data into the other rectangle (acquisition rectangle). The end of formatting frees the formatting rectangle for new acquisitions, whereas the roles of the formatting and acquisition rectangles are exchanged. If the new acquisitions occur before the end of formatting, the new data overwrites the old data.

Tasks 1, 2 and 3 are triggered by hardware interrupts. Error management will be triggered by the detection of an anomaly, by the spacecraft time tags or by a time interrupt (whichever comes first), acting in the latter two cases as a watchdog. The ADSP 21020 provides 4 levels of software interrupts. It is therefore proposed to restrict to short actions (e.g. the reception of a message on the UART line) the activity within the interrupt and to trigger a software interrupt of the adequate priority if more time demanding activity is requested (such as for the interpretation of telecommands).

2.4.1.2 The software structure and languages

The OMEGA software consists in a boot program and a main program. The boot program is resident in PROM. It is written in C and it consists in a subset of the main program capabilities, namely:

- the mandatory services for TC handling
- the reception and interpretation of the “initialization” private TC packet
- a scheduler based on an internal timer, with a clock time of 100 msec (see below).

	MARS EXPRESS OMEGA EXPERIMENT FLIGHT USER MANUAL	Reference : OME-DU-0023-118-IAS Author : M. Berthé Edition : 3 Revision : 0 Rev. date : 15 May 2003 Page : 21
---	---	--

After 60 sec, the boot program checks the content of the initialization packet. If this packet requests an “upload” session which modifies the main program in EEPROM, the boot program retains control until switch-off of OMEGA. A routine specific to the Boot program receives the upload TC’s (memory loads), then writes the EEPROM after checking for the integrity of the complete chain of upload TC. In all other cases, the boot program loads the main program then transfers control. At the EM level, the boot program tasks are performed by the main program.

The OMEGA main program is written in C, with specific implementation of the TEMIC-21000 software interrupt capabilities. It consists in an initialization routine, a polling loop with an idle state, and a set of interrupt triggered routines. Communication interfaces are handled by input or output queues in the 6 Mbyte memory space available. There are three output queues for telemetry:

- high speed channel
- low speed, high priority packets (acknowledges, events, HK reports)
- low speed science packets

The polling loop calls specific subroutines when flags are raised by interrupt triggered routines. The main activity within the polling loop is the compression and formatting of the scientific data (task 6). The formatting routine is specific to OMEGA. The data compression library is that already implemented on the same processor for CIVA, COSIMA and VIRTIS on ROSETTA. The interface is a subroutine call with 7 parameters. This library provides the capability to convert either spatial x spatial data arrays (images) or spatial x spectral data arrays (slices) into unformatted word streams, in either of three modes:

- bit-packing with a bit length selected in one of the parameters
- reversible compression
- wavelet compression, with a fixed output rate in bits / pixels selected by one of the parameters.

The data compression library is written in C, apart from two time critical modules in the wavelet transform routine which are written in DSP 21020 assembly language (400 instructions).

2.4.1.3 The interrupt triggered routines

1. Spacecraft interface interrupt routine.

This interrupt is vectorized, with four flags:

1. end of TC reception
2. end of TM emission (slow telemetry)
3. end of TM emission (high speed dedicated channel)
4. date synch signal

flags 2 to 4 are served within the interrupt routine. The end of TM emission from either channel triggers the load of a new TM packet from the corresponding output queue in the interface buffer. For the slow TM, the high priority queue is tested first, then the low priority queue. If both slow TM queues are empty, a 0 word is written at the base of the output buffer, in compliance with the TM protocol.

	MARS EXPRESS OMEGA EXPERIMENT FLIGHT USER MANUAL	Reference : OME-DU-0023-118-IAS Author : M. Berthé Edition : 3 Revision : 0 Rev. date : 15 May 2003 Page : 22
---	---	--

The TC flag triggers a call to a specific TC interpretation subroutine, through a software interrupt. Apart from the mandatory services, there are four types of OMEGA private TC packets:

- initialization telecommand packet: It defines the operating mode of the experiment, the selection of redundant units and the cooling strategy (cooling time, fixed power or target temperature). At FM level, it is only accepted by the boot program, within the first 60 sec after switch-on. For the EM level software, this packet is handled by the main program.
- parameter telecommand packet: it modifies a table of observation parameters
- activity telecommand packet: it triggers the start, stand-by, resume and stop of observations by the spectrometer. The forced start of subsystems and other test modes can also be initiated by this type of TC.
- Cooling telecommand packet: it modifies the cooling strategy by sending the modified cooling parameters to the spectrometer.

2. Spectrometer interface interrupt routine

This interrupt is vectorized, with four flags:

1. end of emission or reception on the serial line connecting the MEC and the spectrometer
2. end of acquisition from the SWIR C unit
3. end of acquisition from the SWIR L unit
4. end of acquisition from the SWIR V unit

The serial line interface uses a 16 bit protocol. Each message from the spectrometer or to be sent to the spectrometer is appended to an input or output FIFO queue. Therefore, all messages from the spectrometer are always interpreted in the order in which they were received. The messages from the spectrometer unit are the following:

- acknowledge of a message sent by the MEC. The MEC checks for anomalies, which trigger the software interrupt of the error management routine (see below).
- housekeeping data or scanning mirror positions, which are appended at the end of the corresponding streams
- time events corresponding to the beginning and end of a scanning by the IR scanning mirror. These time events control the scheduling of tasks during observations, contrarily to the situation between observations, when this scheduling is controlled by the internal timer. They set or reset the forward scan flag (see below). The end of forward scan sets the formatting flag (see below) and increments the scan number for formatting. Housekeeping data from the platform is formatted a specific science TM packet after a fixed number of scans corresponding to 3.2 seconds of observations. A selected subset is sent as a HK report packet every 12.4 seconds. Both types of packets are placed in the corresponding output queues.

When one of the 3 acquisition flags is set, the corresponding input Fifo is read and, depending on the configuration, stored or added to the adequate location of the acquisition rectangle. Housekeeping data from the visible channel, which is at the beginning of the first Fifo for an image, is stored in the corresponding buffer. If the forward scan flag is reset, the infrared channel data are considered as dark current data and stored in the corresponding buffer.

	MARS EXPRESS OMEGA EXPERIMENT FLIGHT USER MANUAL	Reference : OME-DU-0023-118-IAS Author : M. Berthé Edition : 3 Revision : 0 Rev. date : 15 May 2003 Page : 23
---	---	--

4. Timer interrupt

The internal timer of the DSP 21020 is set at a frequency of 100 msec. The timer increments an internal time, which is initialized as 0. The timer also increments a internal board time, which is updated by the spacecraft through a sequence of a date TC and date synch interrupt. The internal board time is used to time tag all TM packets at generation. The internal time controls a scheduler, i.e. a queue of actions with a trigger time. This is mainly used after boot to define a 50 sec initialization sequence during which the spectrometer main or redundant processor is selected, then the communication is validated, then the cooling parameters are sent to the spectrometer according to the configuration defined by the initialization TC packet.

5. Error management software interrupt routine

It is invoked by two types of events: the detection of an anomaly by any other part of the software, which writes a word indicating the type of anomaly (reset to 0 after service), a time tag from the spacecraft or a timer interrupt (in case the time tag does not come) which trigger a watchdog activity. The main anomalies to be processed are:

- incorrect echo of a message to the spectrometer unit. A retry is performed, and a number of tries is incremented. After three successive failures, a higher level error procedure is invoked, which may ignore the error as coming from an incorrect echo or trigger a hardware reset of the spectrometer
- incorrect number of spectra between two spectrometer time tags. Spectra from the previous scan are integrated in the data.
- two spectrometer time tags of the same type (forward scan and backward scan must alternate). One assumes an alternate type has been missed.
- no echo from the spectrometer after a message, which blocks the outgoing queue (this action requires a watchdog event)

2.4.1.4 The poll loop: compression and formatting

The poll loop goes from idle to idle. After going out of sleep mode (interrupt), the poll loop checks whether the formatting flag is set. If not, it goes back to sleep mode. The formatting rectangle has a size which can be derived from the configuration table, which includes the length of scan and the spectral resolution. This table indicates the level of compression which is requested.

The compression and formatting routine segments the data into subunits of 32 x 64 data. This maximizes data security, as only one of these “sub-slices” is lost upon an SEU in the data stream. This rectangle is first compressed according to the configuration (compression, reversible compression, wavelet compression with one of 16 bit rates). At most 2 TM packets (bit-packing mode) are prepared for each subunit. Upon completion of a TM packet, it is appended to the high speed output queue. If this output queue is full, the routine goes into a sleep cycle.

	MARS EXPRESS OMEGA EXPERIMENT FLIGHT USER MANUAL	Reference : OME-DU-0023-118-IAS Author : M. Berthé Edition : 3 Revision : 0 Rev. date : 15 May 2003 Page : 24
---	---	--

2.4.1.4 Data compression

The compression algorithm used in the OMEGA software is that implemented on 3 experiments on board ROSETTA (CIVA, VIRTIS and the COSIMA target camera). This is performed on rectangles of 64 x 64 data (IR channel), 64 x 48 or 64 x 72 data (VIS channel).

5 compression modes are considered:

- bit-packing (no compression: 12 bits / data)
- reversible compression (typically 4 to 5 bits/data)
- wavelet compression with 1, 1.5 or 2 bits / data.

The actual OMEGA data rate depends on 3 parameters:

- number of spectels: either 352 or 400 (VIS mode)
- number of spectra per sec: 160, 80 or 40 (effective integration time: 5, 10, 20 msec, + 20% for the backscan)
- number of bits /data (compression mode, see above)

For the two observation modes most likely to be used (160 spectra/s, 352 spectels, reversible or 2 bits/data), the output rate is therefore 286 kbits/s or 116 kbits/s (with 4 kbits/s reserved for auxiliary data). During commissioning at Mars, a few observations will be requested in bit-packing (680 kbits/s)

The only case in which the data rate is not predictable from the observation mode (i.e. depending on the information content) is case b (reversible compression). Experience with ISM shows that the maximum range is from 4 to 6 bits/data, with a high probability of being close to 5 bits/data.

The actual data output from the observation mode to within 1%, except with reversible compression, where it can be predicted within a factor 1.55. ESOC can fully predict the number of TM blocks from the observation and compression modes: it is either 12 (bit-packing) or 6 (reversible and wavelet) per sequence of 64 spectra. In 3.2 sec, there are 8, 4 or 2 such sequences, depending on the effective integration time (including possible summing: 5, 10 or 20 msec), hence a range from $2 \times 6 = 12$ to $8 \times 12 = 96$ blocks per interval of 3.2 sec. In nominal operations, bit-packing will never be used, and the range will be from 12 to 48 TM blocks per interval of 3.2 sec. The length of each block will depend on the bit/data value (around 5, or fixed at 2, 1.5 or 1 depending on the compression mode).

 MEX	MARS EXPRESS OMEGA EXPERIMENT FLIGHT USER MANUAL	Reference : OME-DU-0023-118-IAS Author : M. Berthé Edition : 3 Revision : 0 Rev. date : 15 May 2003 Page : 25

2.4.2) Budgets

2.4.2.1. Power budget

POWER DEMAND Out-gassing	INSTRUMENT: OMEGA				UNIT: OMEM + OMEC				MODEL: EM, FM			
	ESTIMATED VALUES: X								MEASURED VALUES:			
Power Lines Description	Average Power BOL [W]				Average Power EOL [W]				Long Peak Power		Short Peak Power	
	Modes				Modes				Peak [W]	Duration [s]	Peak [W]	Duration [s]
	Init	Heating			Init	Heating						
+28V	12	15			12	15			No		No	

POWER DEMAND Mars Observation Stellar Calibration Dark Sky Calibration Simplified Control	INSTRUMENT: OMEGA				UNIT: OMEM + OMEC				MODEL: EM, FM			
	ESTIMATED VALUES: X								MEASURED VALUES:			
Power Lines Description	Average Power BOL [W]				Average Power EOL [W]				Long Peak Power		Short Peak Power	
	Modes				Modes				Peak [W]	Duration [s]	Peak [W]	Duration [s]
	Init	Cooling	Cooling + Obs.	Observ. end								
+28V	12	27	45	12					No		No	

 MEX	MARS EXPRESS OMEGA EXPERIMENT FLIGHT USER MANUAL	Reference : OME-DU-0023-118-IAS Author : M. Berthé Edition : 3 Revision : 0 Rev. date : 15 May 2003 Page : 26
---	---	--

2.4.2.2 Telemetry Budget

OMEGA Telemetry activities versus instrument state:

- **Boot, Init, Upload:**
 - Only solicited TM (acknowledge messages) and event reports at state transition (ie marginal activity)
- **Pre obs:**
 - One HK report every 128 seconds (length = 68 Bytes)
 - One RTU-channel Science packet is generated every 128 seconds (variable length, typically 300 Bytes)
 - Solicited TM
- **Outgassing:**
 - One HK report every 128 seconds (length = 68 Bytes)
 - One RTU-channel Science packet is generated every 128 seconds (variable length, typically 300 Bytes)
 - Solicited TM
- **Obs:**
 - 12 to 96 High speed Science TM packets are generated every 3.2 seconds. Max length of each packet is 1024 Bytes, but expected size is much lower due to data compression. See part 2.4.1.4. for data compression
 - One HK packet is generated every 12.8 seconds (length = 68 Bytes)
 - Solicited TM

	MARS EXPRESS OMEGA EXPERIMENT FLIGHT USER MANUAL	Reference : OME-DU-0023-118-IAS Author : M. Berthé Edition : 3 Revision : 0 Rev. date : 15 May 2003 Page : 27
---	---	--

The OMEGA Telemetry Downlink budget is summarized on the scheme below:

Nominal case : High rate TM operational

RTU link,

OMEGA typical Observation (Mars Observation, Stellar calibration, Dark Sky calibration):

Mode	Packet type	Packet production rate	Packet size All headers included (Bytes)	Data production rate (bits /sec)	Total Data production rate (bits /sec)	Mean duration (sec)	Total data (kbits)
Pre -Obs	HK (3.25) Private (20.3)	1 per 128 s 1 per 128 s	68 380 (variable)	4,25 23,75	28	7200	201
Observation	HK (3.25)	1 per 12,8 s	68	42,5	42,5	360 to 1200	15,5 to 51
Post -Obs	HK (3.25) Private (20.3)	1 per 128 s 1 per 128 s	68 380 (variable)	4,25 23,75	28	600	16,8

	MARS EXPRESS OMEGA EXPERIMENT FLIGHT USER MANUAL	Reference : OME-DU-0023-118-IAS Author : M. Berthé Edition : 3 Revision : 0 Rev. date : 15 May 2003 Page : 28
---	---	--

**High Speed link (1355),
OMEGA typical Observation (Mars Observation, Stellar calibration, Dark Sky calibration):**

Mode	Packet type	Packet production rate	Packet size All headers included (Bytes)	Data production rate (bits /sec)	Total Data production rate (bits /sec)	Mean duration (sec)	Total data (Mbits)
Pre -Obs	Science (20.13)	0	0	0	0	0	0
Obs.	Science (20.13)	15 per sec (Up to 33 per sec in case of non compressed data)	4096 maximum, depending on data compression	Minimum 116 kbits / s Typical 286 kbits / s Maximum 780 kbits / s See note	Minimum 116 kbits / s Typical 286 kbits / s Maximum 780 kbits / s See note	360 to 1200	40 to 400 Mbits
Post -Obs	Science (20.13)	0	0	0	0	0	0

Note : the maximum size of 4096 is not reached for all 33 packets sent during one second, so the maximum rate is 780 kbits/sec

 MEX	MARS EXPRESS OMEGA EXPERIMENT FLIGHT USER MANUAL	Reference : OME-DU-0023-118-IAS Author : M. Berthé Edition : 3 Revision : 0 Rev. date : 15 May 2003 Page : 29
---	---	--

Contingency mode: High rate TM Not operational

**RTU link only in case of IEEE 1355 link failure,
OMEGA typical Observation (Mars Observation, Stellar calibration, Dark Sky calibration):**

Mode	Packet type	Packet production rate	Packet size All headers included (Bytes)	Data production rate (bits /sec)	Total Data production rate (bits /sec)	Mean duration of generation (sec)	Total data (kbits)
Pre -Obs	HK (3.25) Private (20.3)	1 per 128 s 1 per 128 s	68 380 (variable)	4,25 23,75	28	7200	201
Observation	HK (3.25) Private (20.3)	1 per 12,8 s 15 per sec	68 1300 maximum	42,5 116 kbits / s	42,5 116 kbits / s see note	360	40 Mbits
Post -Obs	HK (3.25) Private (20.3)	1 per 128 s 1 per 128 s	68 380 (variable)	4,25 23,75	28	600	16,8

Note : This is the instrument data production rate.

The data are stored in the instrument memory in a stack with a size of 40 Mbits (this corresponds to 6 minutes of observation) and has to be polled by OBDH at a rate of one packet per second, after completion of the observation. The post observation period for OMEGA has to be extended to 100 minutes (in order to poll the 6000 generated TM packets)

3) Detailed description

3.1) Digital data interface to the Spacecraft.

The **MEI** handles both the digital data interface between the Omega experiment and the spacecraft (OMEM/SpaceCraft Interface Controller) and between the OMEM and the OMEC (OMEM/OMEC interface controller).

The main functions of the OMEM/SpaceCraft interface controller are:

- Reception, storage and dispatching of the digital telecommands (Memory Load Command).
- Reception and handling of the on-board time (MLC & Timer Synchronisation pulse).

	<p>MARS EXPRESS OMEGA EXPERIMENT FLIGHT USER MANUAL</p>	<p>Reference : OME-DU-0023-118-IAS Author : M. Berthé Edition : 3 Revision : 0 Rev. date : 15 May 2003 Page : 30</p>
---	---	---

Generation and transfer of data to the slow telemetry channel (Serial Data Telemetry).

Generation and transfer of scientific data to the on-board mass memory through the IEEE 1355 links.

The main functions of the OMEM/OMEC interface controller are:

Communication with the SEA (Spectrometer Electronic Assembly) by serial asynchronous link; 9 bits words, 51 kbps clock.

Data reception from the camera through three high speed lines, one from the VNIR channel (at 1.2 Mbit/s) and two from SWIR channels (at 1 Mbit/s).

The MEI communicates with the SEA via a serial redundant interface



MARS EXPRESS
OMEGA EXPERIMENT
FLIGHT USER MANUAL

Reference : OME-DU-0023-118-IAS
Author : M. Berthé
Edition : 3
Revision : 0
Rev. date : 15 May 2003
Page : 31

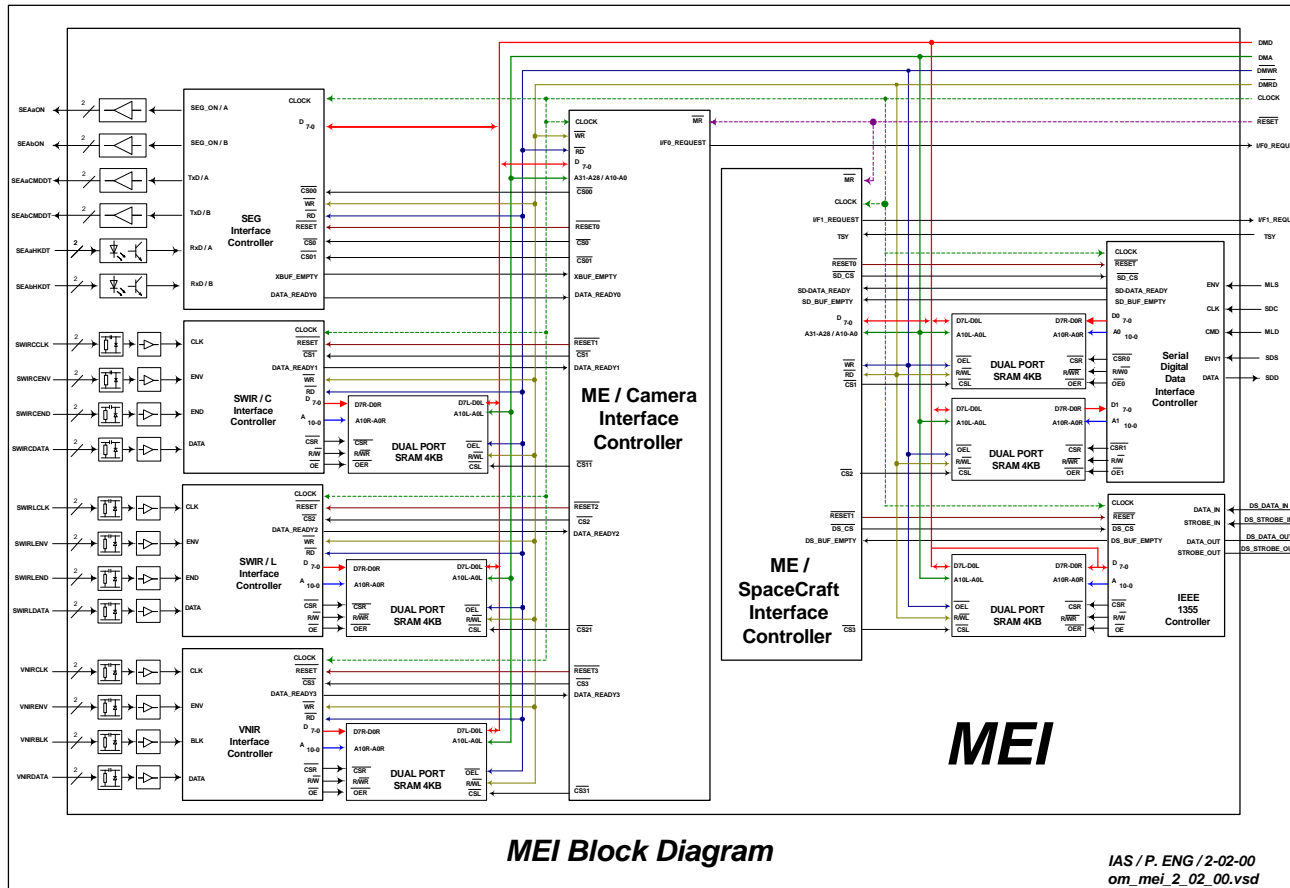



Figure 3.3.2.2.2: OMEM Interfaces Block Diagram

	<p>MARS EXPRESS OMEGA EXPERIMENT FLIGHT USER MANUAL</p>	<p>Reference : OME-DU-0023-118-IAS Author : M. Berthé Edition : 3 Revision : 0 Rev. date : 15 May 2003 Page : 32</p>
---	---	---

3.2) Power interface to the Spacecraft.

MEP is the main electronics power unit which insures the following functions:

- reception of the High Power commands.
- selection of MECn or MECr,
- +5 V power supply generation for OMEM, transmission of the +28VnSEPN or +28VrSEPr voltage and the +28VnrSKC towards camera,
- MEPn or MEPr Relay Switch Status generation,
- MECn or MECr Relay Switch Status generation,
- SKCs Relay Switch Status generation.

The MEP board gathers:

- relays switched by High Power commands for voltage distribution,
- two cold redundant DC-DC isolated converters delivering +5.2 V, 12 W from the main bus.



MARS EXPRESS
OMEGA EXPERIMENT
FLIGHT USER MANUAL

Reference : OME-DU-0023-118-IAS
Author : M. Berthé
Edition : 2
Revision : 0
Rev. date : 18 Oct. 2001
Page : 33

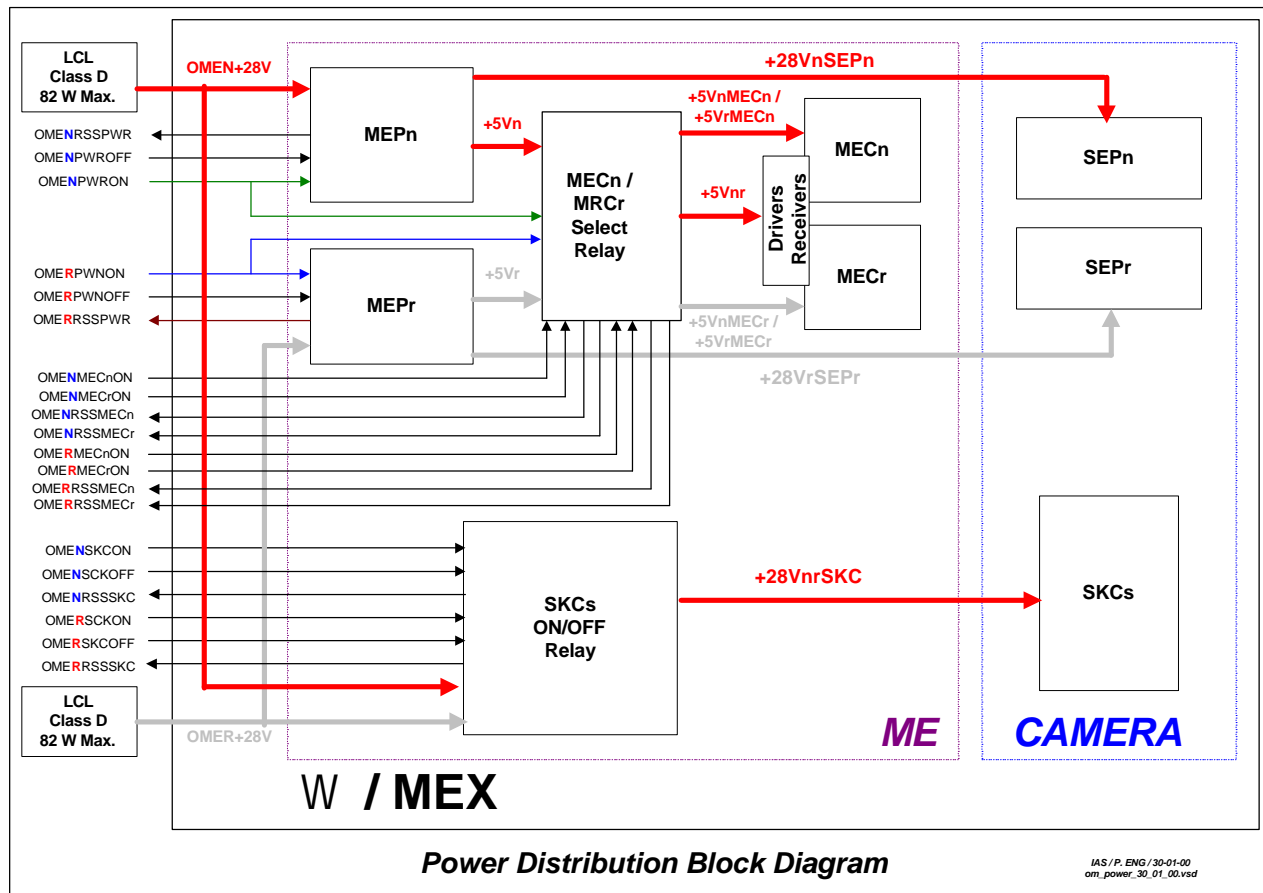

	MARS EXPRESS OMEGA EXPERIMENT FLIGHT USER MANUAL	Reference : OME-DU-0023-118-IAS Author : M. Berthé Edition : 3 Revision : 0 Rev. date : 15 May 2003 Page : 34
---	---	--

4) Instrument Operations

4.1) Overview of operating principles

The instrument sequencing is programmed thanks to MLC commands which are managed by the Orbiter TC on-board system which transmits them to the instrument at pre-defined time. The conditions of observation will be defined by the Science Team on the basis of the orbital predicts.

OMEGA will never start autonomously an observation (the programmed mode has been removed from Mars 96 Operations). Therefore, an OMEGA observation is the interval between the reception of a “Start” TC and a “Stop” TC, hence fully controllable by the TC sequencer. The high resolution observations will be performed close to pericentre, while the global observations will be performed close to a true anomaly of 90°. For each observation orbit, the OMEGA team will provide the requested time for the sending of the Start and Stop TC.

4.1.1. Observation programs

The flight programs that can be used are summarized in the list below. The same programs can be checked during on-ground integration and tests by sending commands with a slightly modified content.

4.1.1.1 Mars Observation:

Mars Observation program is based on the following sequence of FCP’s as described in this manual

OME_N_ON
OME_OBS
OME_OFF

The timing for these procedures is referenced to the Spacecraft pericentre time (T_{peri}). The precise time lining will be defined based on scientific objective, actual SC orbit and attitude. Rough timeline is as follow

- OME_N_ON: $T_{peri} - 2$ hours
- (instrument cooling down)
- OME_OBS: $T_{peri} - 5$ (to 20) minutes to $T_{peri} + 5$ (to 20) minutes
- OME_OFF at completion of observation

S/C attitude during this observation program:

	MARS EXPRESS OMEGA EXPERIMENT FLIGHT USER MANUAL	Reference : OME-DU-0023-118-IAS Author : M. Berthé Edition : 3 Revision : 0 Rev. date : 15 May 2003 Page : 35
---	---	--

During the observation phase ($T_{\text{peri}} - 5/20$ minutes to $T_{\text{peri}} + 5/20$ minutes), the spacecraft attitude should be oriented with the OMEGA line of sight towards the Nadir (Nadir pointing) or in a Off-nadir pointing, as defined below:

Off-nadir Pointing: OMEGA needs off-nadir pointing to scan the surface of Mars along track parallel to the Nadir track. The spacecraft attitude is such that OMEGA line of sight at each moment should be in the direction of a point on the surface of Mars situated at a given angle in a direction perpendicular to the track (nominally called as across-track pointing). This across track pointing should be maintained during the observation period up to 20 minutes. The maximum off-nadir pointing angle could be 30 degrees.

Remarks about Off-Nadir Pointing:

- What is required is fixed angular offset (i.e. no specific angular pointing profile to be followed).
- In normal instrument mode, off-nadir pointing (across-track) is mainly driven by the ground track repetition to allow several views of the same target.
- During OMEGA high-resolution mode (5 km) of operations, off-nadir pointing may be needed every orbit.
- In total this concerns only a ‘small’ fraction of the orbits (typically 200 to 500 out of 2000)
- Both across-track and along-track may be required.

4.1.1.2 Stellar calibration:

Stellar calibration program is based on the following FCPs

OME_N_ON
OME_OBS
OME_OFF

- OME_N_ON: $T_{\text{observation}} - 2$ hours
- in between instrument cooling down
- OME_OBS: Observation will 30 minutes
- OME_OFF at completion of observation

S/C attitude during this observation program:

Stellar Calibration: The OMEGA line of sight should be oriented such that it scans over the location of a given star in steps. The direction of scanning is around spacecraft axis (TBD) (perpendicular to spectrometer slit). The spacecraft should scan over the full 8.8° FOV with a rate of 30 arcsec per sec. This mode of operation will be needed in cruise and routine operations phase of the MEX mission.

	MARS EXPRESS OMEGA EXPERIMENT FLIGHT USER MANUAL	Reference : OME-DU-0023-118-IAS Author : M. Berthé Edition : 3 Revision : 0 Rev. date : 15 May 2003 Page : 36
---	---	--

4.1.1.3 Dark Sky calibration

Dark Sky calibration program is based on the following FCPs

OME_N_ON
OME_OBS
OME_OFF

- OME_N_ON: $T_{\text{observation}} - 2$ hours
- in between instrument cooling down
- OME_OBS: Observation will last 30 minutes
- OME_OFF at completion of observation

S/C attitude during this observation program:

The OMEGA line of sight should be oriented so that it looks in a direction with no bright star.

4.1.1.4 Simplified Control

This is a test mode allowing to verify all the functionalities of the instrument with a program similar to an observation, but generating more housekeeping information.

The Simplified control program is based on the following FCPs

OME_N_ON
OME_OBS
OME_OFF

- OME_N_ON: $T_{\text{observation}} - 10$ minutes
- in between instrument cooling down
- OME_OBS: Observation will last 10 minutes
- OME_OFF at completion of observation

S/C attitude during this observation program:

Not important

4.1.1.5 Outgassing

Outgassing program is used to remove pollution that may stick on the Instruments Optics and detectors by heating the some OMEC parts.

It is base on FCP: OME_OUTGAS lasting 2 hours

 MEX	MARS EXPRESS OMEGA EXPERIMENT FLIGHT USER MANUAL	Reference : OME-DU-0023-118-IAS Author : M. Berthé Edition : 3 Revision : 0 Rev. date : 15 May 2003 Page : 37
---	---	--

S/C attitude during this observation program:

Not important

	MARS EXPRESS OMEGA EXPERIMENT FLIGHT USER MANUAL	Reference : OME-DU-0023-118-IAS Author : M. Berthé Edition : 3 Revision : 0 Rev. date : 15 May 2003 Page : 38
---	---	--

4.2 Nominal Operation Plan

4.2.1 Ground operation plan

Following tests will be carried out at system level AIT:

4.2.1.1 Full Performance Test

The FPT gathers several programs which duration is nominal with respect to the flight conditions. They are based on the in-flight “Observation ” program as they are presented in section 4.1. They give the possibility to verify the general behavior of the instrumentation plus each of the TM/TC interfaces with the S/C in the real conditions but the working time of the cryocoolers that is strongly reduced (4 mn only) and the lack of scientific data.

4.2.1.2 Limited Performance Test

The LPT gathers two programs with a limited duration. They are based on the in-flight “Simplified Control” one as it is presented in section 4.1. They give the possibility to verify the general behavior of the instrumentation plus each of the TM/TC interfaces with the S/C in the nominal conditions.

4.2.1.3 GO-NOGO Test

Same as Limited Performance Test

4.2.1.4 Specific Tests

NA

	MARS EXPRESS OMEGA EXPERIMENT FLIGHT USER MANUAL	Reference : OME-DU-0023-118-IAS Author : M. Berthé Edition : 3 Revision : 0 Rev. date : 15 May 2003 Page : 39
---	---	--

4.2.2 In Flight Operation plan

Referring to the programs that are listed in § 4.2, they are proposed to be activated during the Cruise and Orbital phases according to the following chronology:

Phase	Program	Activation
Cruise	Simplified Control	One to two times, 10 to 30 days after launch
Cruise	Observation or Stellar Calibration	Once every 2 months (instrument alignment control and check-out plus)
Cruise	Out-gassing	Once, one month before arrival to Mars (optional)
Cruise	Observation	Once before injection on Mars orbit
Orbit	Observation	Once after injection on Mars orbit (instrument check-out)
Orbit	Out-gassing	Once, before first observation (optional)
Orbit	Observation	Once after injection on Mars orbit (instrument check-out before operation)
Orbit	Stellar Calibration	Once for alignment control and once every 6 months
Orbit	Observation	Once per orbit

4.3) Failure detection and Recovery Strategy

4.3.1) Failure detection

OMEGA does not have any autonomous failure detection and recovery. Any anomaly of OMEGA has to be diagnosed through TM dumped to ground. The OMEGA anomaly recovery is possible only via power cycling the instrument; The instrument will be switched Off and then switched On again after reconfiguration of the redundant elements.

Omega instrument is switched OFF after each observation period (lasting a maximum of some hours). Thus it is fully accepted that the instrument is OFF in case of failure and that one (or more) Observations are lost due to a failure.

4.3.2) Software Update

The OMEGA digital electronic hardware design, based on a specific 3D-integrated CDPU developed in IAS, uses EEPROMs to store the main flight software, with a dedicated Start-up segment in PROM. The PROM program is active during 60 sec after power-on unless an upload session is requested by the initialisation TC.

A Software upload is foreseen as a contingency in the following cases:

- non nominal operation of the software which could be attributed to a degradation of the EEPROM through a dump of its content.
- non nominal operation of the experiment which could be attributed to a hardware degradation, and which can be alleviated by a change in the main software

	MARS EXPRESS OMEGA EXPERIMENT FLIGHT USER MANUAL	Reference : OME-DU-0023-118-IAS Author : M. Berthé Edition : 3 Revision : 0 Rev. date : 15 May 2003 Page : 40
---	---	--

- anomalous operation of the software in observational conditions which could not be tested before launch.
- unexpected features in the scientific data, which incur a strong, request by the scientific team for a dedicated software capability.

The EEPROMs have to be completely erased before any rewrite operation. Therefore, the whole flight software has to be uplinked at each modification. The size of the flight software is around 100 Kbytes.

It is likely that very few (if any) software upload sessions will be requested by the OMEGA team during the mission. A detailed description of the upload scenario is presented in annex 1. It fully complies with the existing mandatory services and capabilities of the spacecraft and TM/TC link as described in the MEX SGICD. It is clear that an upload session for OMEGA can be implemented at a time, which is not conflicting with any other operational request (e.g. at apocenter). The upload scenario needs to be fully validated by ESOC, and a test sequence of the upload needs to be included in the experiment AIT process.

	MARS EXPRESS OMEGA EXPERIMENT FLIGHT USER MANUAL	Reference : OME-DU-0023-118-IAS Author : M. Berthé Edition : 3 Revision : 0 Rev. date : 15 May 2003 Page : 41
---	---	--

5) Mode description

5.1) Summary of all Nominal and back-up modes

OMEGA can be in one of 7 states:

- Off
- Boot
- Upload
- Initialization
- Pre-observation
- Observation
- Outgassing

OMEGA is always in the boot state after switch-on, for 60 sec. In this state, OMEGA is controlled by the boot program. After 60 sec, the initialization TC is tested. If it contains a validated “upload” TC element, OMEGA goes to the Upload state, which is also run by the boot program, and in which only Upload TC’s are implemented. Otherwise, control is transferred to the EEPROM program (main program) and the initialization state is entered. When entering the initialization state, the communication with the spectrometer (SEG) is initiated. After 30 additional sec (90 sec total since switch-on), the initialization TC is activated. If it contains a validated “outgassing” TC element, OMEGA goes to the Outgassing state, where no further TC is implemented. Otherwise, OMEGA goes to the Pre-Observation state.

OMEGA is transferred from the pre-observation state to the observation state and back by sending one of the four TC “START”, “RESUME”, “STAND-BY”, “STOP” (see below). The observation state is the only state in which telemetry is generated on the high speed dedicated 1355 line.

	MARS EXPRESS OMEGA EXPERIMENT FLIGHT USER MANUAL	Reference : OME-DU-0023-118-IAS Author : M. Berthé Edition : 3 Revision : 0 Rev. date : 15 May 2003 Page : 42
---	---	--

5.2) Mode transition diagram

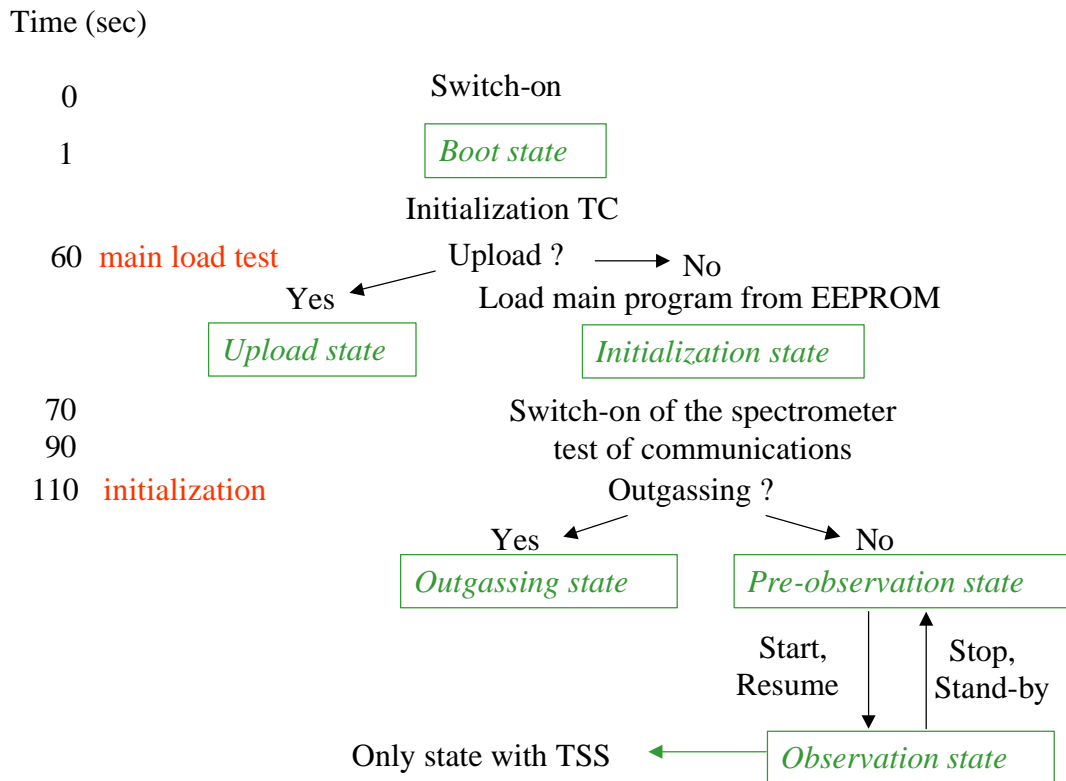

5.3) Detailed mode description

5.3.1) Boot

OMEGA is always in the boot state after switch-on, for 60 sec. In this state, OMEGA is controlled by the boot program that is stored in a ROM memory (read-only memory). No action is performed, the instrument waits for reception of a TC, that is acknowledge (if valid) and stored for execution at end of this mode.

After 60 sec, the initialization TC is tested. If it contains a validated “upload” TC element, OMEGA goes to the Upload state. Otherwise, control is transferred to the EEPROM program (main program) and the initialization state is entered.

5.3.2) Upload

In this state, OMEGA is controlled by the boot program that is stored in a ROM memory (read-only memory).

In this state, only Upload TC’s and mandatory services are accepted by the instrument.

The instrument will await the number of Upload TCs as defined in the parameter of the init TC received before. All the Memory load data’s received during this period are stored in the

	MARS EXPRESS OMEGA EXPERIMENT FLIGHT USER MANUAL	Reference : OME-DU-0023-118-IAS Author : M. Berthé Edition : 3 Revision : 0 Rev. date : 15 May 2003 Page : 43
---	---	--

RAM upper part until reception of the whole set of blocks corresponding to the EEPROM code. Once all the TCs are received and upon reception of a confirmation TC (Upload TC to a specific predefined address), the whole new program will be loaded into the EEPROM. The number of valid blocks is checked with respect to that indicated in the init TC, and a specific Event report is generated after successful completion of the EEPROM upload.

All the other states defined below are executed from the program contained in this EEPROM. In case of failure to get the whole program (CRC error in TCs, missing TC, no validation TC), the program is not uploaded and an anomalous event report is generated

See detailed description of the procedure in part 7.3.2

5.3.3) Initialization

After 60 sec, control is transferred by the boot program to the main program loaded from EEPROM, and OMEGA goes to the initialization state, unless the initialization TC is an upload.

The Initialization TC has to be received by OMEGA more than 1 sec and less than 60 sec after switch-on.

The initialization TC is activated after 110 sec. If no initialization has been received, the default initialization is activated. If several valid initialization TC are received before the 60 sec limit, only the last received is activated.

Activation of the initialization TC transfers from the initialization state to the pre-observation state, unless the initialization is an outgassing, in which case OMEGA goes to the outgassing state (no private TC is implemented).

5.3.4) Pre-observation

During this phase, the coolers are activated as defined in the Init TC, an relevant detectors are cooled.

During this phase an HK report packet and Science (RTU channel) are generated every 128 seconds.

5.3.5) Observation

In this state, the science data are generated. The instrument perform all measurements described in chapter 1.2, based on the parameter received in a parameter TC.

An observation is defined by the choice of the following parameters:

- swath length
- integration time
- scanning speed
- spectral resolution
- data compression mode

12 to 96 High speed Science TM packets are generated every 3.2 seconds.

One HK packet is generated every 12.8 seconds.

 MEX	MARS EXPRESS OMEGA EXPERIMENT FLIGHT USER MANUAL	Reference : OME-DU-0023-118-IAS Author : M. Berthé Edition : 3 Revision : 0 Rev. date : 15 May 2003 Page : 44
---	---	--

5.3.6) Outgassing

During this specific mode, performed every several month (refer to 4.1), the instrument focal planes are heated.

No science packets are generated.

One HK packet is generated every 128 seconds.

	MARS EXPRESS OMEGA EXPERIMENT FLIGHT USER MANUAL	Reference : OME-DU-0023-118-IAS Author : M. Berthé Edition : 3 Revision : 0 Rev. date : 15 May 2003 Page : 45
---	---	--

6) Interfaces

6.1) Power

Power interface to the S/C is performed via a redundant DC/DC power converter. Primary power from S/C is switched with a relay

- Selection of the S/C activated relays: Power Units N or R switched ON
 - for Nominal power channel: OMENPWON
 - for Redundant power channel: OMERPWON
 -
- Selection of the S/C activated relays: Power Units N or R switched OFF
 - for Nominal power channel: OMENPWROFF
 - for Redundant power channel: OMERPWROFF

A specific relay enables the power distribution to the SKC (Cryo coolers)

- Switch ON the SKC power lines
 - Via Nominal Power Channel: OMENSKCON
 - Via Redundant Power Channel: OMERSKCON
- Switch OFF the SKC power lines
 - Via Nominal Power Channel: OMENSKCOFF
 - Via Redundant Power Channel: OMERSKCOFF

Typical power profiles are given in the resources section (4.2.2)

6.2) Mechanical

OMEGA Mars Express Experiment is composed of 3 elements units:

- Electronic Unit: OMEM (New development for Mars Express). Mass = 5.1 kg
- Camera Unit: OMEC (Re-flight of the Mars 96 Spare Camera, with some rebuild sub-systems). Mass = 23.8 kg
- Inter-unit Harness: OMEH (New development for Mars Express). Mass = 0.4 kg

6.3) Thermal

The instrument is composed of two main sub-parts:

- the camera (OMEC)
- the main Electronic (OMEM)

The operating temperature range of OMEM is [-30°C ÷ +40°C]

Roughly the camera has three main levels of temperature:

	MARS EXPRESS OMEGA EXPERIMENT FLIGHT USER MANUAL	Reference : OME-DU-0023-118-IAS Author : M. Berthé Edition : 3 Revision : 0 Rev. date : 15 May 2003 Page : 46
---	---	--

the spectrometer temperature (<190 K) for background reducing purpose
the detector temperature (70 K) for dark current reduction and measurement
conditioning purpose
the peripheral equipment at room temperature (electronics ...)

OMEM is a Collectively Controlled unit

OMEC is partially Individually and Collectively Controlled unit:

The detector is cooled by the way of a cryogenerator which is controlled by the experiment itself.

The other stages (room temperature and spectrometer temperature) are controlled by the S/C.

6.4) Optical

OMEGA Instrument Field of view

OMEC:

Martian surface pointing direction:

Sensor orientation: nadir or Nadir off pointing and inertial mode

Refer to part 4.1.1 for pointing requirements

Field of view: total: 8.8°

OMEM: NA.

OMEH: NA.

6.5) Data

6.5.1) RTU Telemetry

RTU telemetry interface is handled by an FPGA. Nominal/Redundant line selection is performed autonomously by the instrument, based on active line detection.

The same redundancy selection (ie Nominal or Redundant) is done for both RTU Telemetry and Telecommand.

Either Nominal or Redundant RTU TM/TC can be selected independently for the Main DPU (MECn) or the redundant one (MECr).

Telemetry formats are described in part 9.

	MARS EXPRESS OMEGA EXPERIMENT FLIGHT USER MANUAL	Reference : OME-DU-0023-118-IAS Author : M. Berthé Edition : 3 Revision : 0 Rev. date : 15 May 2003 Page : 47
---	---	--

6.5.2) High Speed Telemetry

6.5.2.1. Link start-up:

Text in *Italic* does not represent actions for Omega, but actions performed by the S/C.

- *Before instrument power on:*
 - *SSMM power on (N/R selection)*
 - *Reset signal inactive*
 - *SMCS in ready state*
 - *Wait for null tokens*
- Omega On
 - Reset signal inactive
 - Init SMCS
 - SMCS to ready state (no NULL token send)
- *S/C DMS send TC (RTU link) to Omega: (255.3) = Start HS-link*
- Omega receive TC (255.3) and start sending NULL
- *SSMM receive NULL from Omega*
- *SSMM sent FCC and NULL to Omega*
- Omega receive NULL and start sending FCC and NULL (link is up)

6.5.2.2. Data transmission from Omega to SSMM

- Verify that FCC and NULL are received from DMS: status OK or NOT_OK
- If OK:
 - Send packetized Science data when available (service 20.13)
- If NOT_OK:
 - Omega stop FCC and NULL transmission
 - Omega sent an Anomalous Event Report (service 5.4) via RTU link

6.5.2..3 Link closure at end of Omega science acquisition

- Omega send TM (20.12) via RTU link: Report Science data generation stopped at packet boundary.

6.5.2.4 Link closure by DMS (transmission error or packet store boundary reached)

- *DMS sent a TC (20.11) stop SC report via HS link.*
- Omega receive TC (20.11) (stop SC report via HS link) via RTU link

	MARS EXPRESS OMEGA EXPERIMENT FLIGHT USER MANUAL	Reference : OME-DU-0023-118-IAS Author : M. Berthé Edition : 3 Revision : 0 Rev. date : 15 May 2003 Page : 48
---	---	--

- Omega generates an acceptance report for this TC (service 1.1)
- Omega send TM (20.12) via RTU link: Report Science data generation stopped at packet boundary.
- *DMS will stop link*

6.6) Control

Omega Control is achieved through use of Discrete TM pulses and serial RTU TCs. Time update TC is validated with a time synchronization Pulse from RTU.

6.6.1) Pulse Commands

- Selection of the S/C activated relays: Power Units N or R switched ON
 - for Nominal power channel: OMENPWRON
 - for Redundant power channel: OMERPWRON
 -
- Selection of the S/C activated relays: Power Units N or R switched OFF
 - for Nominal power channel: OMENPWROFF
 - for Redundant power channel: OMERPWROFF
- Switch ON the SKC power lines
 - Via Nominal Power Channel: OMENSKCON
 - Via Redundant Power Channel: OMERSKCON
- Switch OFF the SKC power lines
 - Via Nominal Power Channel: OMENSKCOFF
 - Via Redundant Power Channel: OMERSKCOFF
- Selection of the MEC boards N or R (DPU)
 - Via nominal command lines:
 - for MECn: OMENMECNON
 - for MECr: OMENMECRON
 - Via Redundant command lines:
 - for MECn: OMERMECNON
 - for MECr: OMERMECRON

 MEX	MARS EXPRESS OMEGA EXPERIMENT FLIGHT USER MANUAL	Reference : OME-DU-0023-118-IAS Author : M. Berthé Edition : 3 Revision : 0 Rev. date : 15 May 2003 Page : 49
---	---	--

Short Name	MEDOC TC Name	Medoc Std Designation	OBDAH address	HPC line #
OMENPWROFF	ZOM02650PWOF	OMEGA_PWR_OFF (Nom.)	9	HPC 10 N
OMENMECNON	ZOM02651MECN	OMEGA_MECN_EN (Nom.)	A	HPC 11 N
OMENMECRON	ZOM02652MECR	OMEGA_MECR_EN (Nom.)	B	HPC 12 N
OMENSKCON	ZOM02653SKC1	OMEGA_SKC_ON (Nom.)	C	HPC 13 N
OMENSKCOFF	ZOM02654SKC0	OMEGA_SKC_OFF (Nom.)	D	HPC 14 N
OMENPWRON	ZOM02655PWON	OMEGA_PWR_ON (Nom.)	8	HPC 9 N
OMERPWROFF	ZOMR2650PWOF	OMEGA_PWR_OFF (Red.)	89	HPC 10 R
OMERMECNON	ZOMR2651MECN	OMEGA_MECN_EN (Red.)	8A	HPC 11 R
OMERMECRON	ZOMR2652MECR	OMEGA_MECR_EN (Red.)	8B	HPC 12 R
OMERSKCON	ZOMR2653SKC1	OMEGA_SKC_ON (Red.)	8C	HPC 13 R
OMERSKCOFF	ZOMR2654SKC0	OMEGA_SKC_OFF (Red.)	8D	HPC 14 R
OMERPWRON	ZOMR2655PWON	OMEGA_PWR_ON (Red.)	88	HPC 9 R

6.6.2) RTU Serial Telecommands

RTU telecommand interface is handled by an FPGA. Nominal/Redundant line selection is performed autonomously by the instrument, based on active line detection.

The same redundancy selection (ie Nominal or Redundant) is done for both RTU Telemetry and Telecommand.

Either Nominal or Redundant RTU TM/TC can be selected independently for the Main DPU (MECn) or the redundant one (MECr).

Telecommand formats are described in part 9.

	MARS EXPRESS OMEGA EXPERIMENT FLIGHT USER MANUAL	Reference : OME-DU-0023-118-IAS Author : M. Berthé Edition : 3 Revision : 0 Rev. date : 15 May 2003 Page : 50
---	---	--

7) Nominal and contingency operations procedures

7.1) Ground test sequence

As defined in 4.2

7.2) Flight Control Procedure/ Contingency Recover procedure

OMEGA FCP's and CRP's are listed in the FOP.

The table below gives reference of the status of all OMEGA Procedure as on May 15 th, 2003.

Vol	Sub-sect.	Ch	PL ID	Procedure ID	Procedure Title	Status
5	7	2	OMEGA	OM-MTL-001	OMEGA Timeline	Validated in SVT-2/3
5	7	2	OMEGA	OM-FCP-001	OMEGA Nominal Switch ON	Validated in SVT-2
5	7	2	OMEGA	OM-FCP-002	OMEGA Initialisation (Normal observation with cooler set)	Validated in SVT-2
5	7	2	OMEGA	OM-FCP-003	OMEGA Pre-observation	Validated in SVT-2
5	7	2	OMEGA	OM-FCP-004	OMEGA Start Write Operations to SSMM	Validated in SVT-2
5	7	2	OMEGA	OM-FCP-005	OMEGA Stop Write Operations to SSMM	Validated in SVT-2
5	7	2	OMEGA	OM-FCP-006	OMEGA Switch OFF	Validated in SVT-2
5	7	2	OMEGA	OM-FCP-009	OMEGA Update Parameter	To be validated
5	7	2	OMEGA	OM-FCP-011	OMEGA Reset SMCS and Start HS Link	To be validated
5	7	2	OMEGA	OM-FCP-012	OMEGA Update Cooling Parameter - Voltage Definition	To be validated
5	7	2	OMEGA	OM-FCP-013	OMEGA Update Cooling Parameter - Temperature Definition	To be validated
5	7	2	OMEGA	OM-FCP-075	OMEGA Selection of Nominal TM/TC Branch	To be validated
5	7	2	OMEGA	OM-FCP-076	OMEGA Time Update	To be validated
5	7	2	OMEGA	OM-FCP-077	OMEGA Get Status for Write Operation	To be validated



**MARS EXPRESS
OMEGA EXPERIMENT
FLIGHT USER MANUAL**

Reference : OME-DU-0023-118-IAS
 Author : M. Berthé
 Edition : 3
 Revision : 0
 Rev. date : 15 May 2003
 Page : 51

5	7	2	OMEGA	OM-FCP-078	OMEGA Connection Test	To be validated
5	7	2	OMEGA	OM-FCP-081	OMEGA Start and Stop HK Packet Generation	To be validated
5	7	2	OMEGA	OM-FCP-082	OMEGA Enable Science Packet Generation	To be validated
5	7	2	OMEGA	OM-FCP-083	OMEGA Disable Science Packet Transfer Generation	To be validated
5	7	2	OMEGA	OM-FCP-050	OMEGA Switch ON - Run Test Observation - Switch OFF	DELETED
5	7	2	OMEGA	OM-FCP-051	OMEGA Perform Outgassing	To be validated
5	7	2	OMEGA	OM-FCP-058	OMEGA Forced Stop (Manual) of Cryo Cooler	Validated in SVT-2
5	7	2	OMEGA	OM-FCP-059	OMEGA Forced Start (Manual) of Cryo-cooler	To be validated
5	7	2	OMEGA	OM-FCP-062	OMEGA Stop Observation and Coolers	Validated in SVT-2
5	7	2	OMEGA	OM-FCP-063	OMEGA Start Observation with Calibration	Validated in SVT-2
5	7	2	OMEGA	OM-FCP-064	OMEGA Resume Observation without Calibration	Validated in SVT-2
5	7	2	OMEGA	OM-FCP-065	OMEGA Change Spatial Summing During Observation to Summation 1	Validated in SVT-2
5	7	2	OMEGA	OM-FCP-066	OMEGA Change Spatial Summing During Observation to Summation 2	Validated in SVT-2
5	7	2	OMEGA	OM-FCP-067	OMEGA Change Spatial Summing During Observation to Summation 4	Validated in SVT-2
5	7	2	OMEGA	OM-FCP-068	OMEGA Hold Observation	Validated in SVT-2
5	7	3	OMEGA	OM-CRP-500	OMEGA Anomaly Recovery - Top Level Guideline	TBW
5	7	3	OMEGA	OM-CRP-505	OMEGA Redundant Switch ON	To be validated
5	7	3	OMEGA	OM-CRP-510	OMEGA Nomial Switch ON with Redundant MEC (MECr)	Validated in SVT-3
5	7	3	OMEGA	OM-CRP-516	OMEGA Selection of Redundant TM/TC Branch	To be validated
5	7	3	OMEGA	OM-CRP-517	OMEGA Initialisation with Redundant IEEE Link to SSMM	To be validated
5	7	3	OMEGA	OM-CRP-518	OMEGA Initialisation with Redundant OMEC Subsystem	Validated in SVT-3

	MARS EXPRESS OMEGA EXPERIMENT FLIGHT USER MANUAL	Reference : OME-DU-0023-118-IAS Author : M. Berthé Edition : 3 Revision : 0 Rev. date : 15 May 2003 Page : 52
---	---	--

					Configuration	
5	7	3	OMEGA	OM-CRP-525	OMEGA Emergency Switch OFF	TBW
5	7	3	OMEGA	OM-CRP-540	OMEGA Redundant Switch OFF	TBW
5	7	3	OMEGA	OM-CRP-541	OMEGA Switch ON in Complete Redundant Configuration	TBW
5	7	3	OMEGA	OM-CRP-545	OMEGA Reset TM Output Buffer	To be validated
5	7	2	OMEGA	OM-CRP-561	OMEGA Complete EEPROM Software Upload	To be validated
5	7	2	OMEGA	OM-CRP-562	OMEGA Dump Memory	To be validated
5	7	2	OMEGA	OM-CRP-519	OMEGA Send One Packet on SSMM Link	TBW
5	7	2	OMEGA	OM-CRP-TBD	OMEGA Stop Science Data Acquisition	TBW
5	7	3	OMEGA	OM-CRP-550	OMEGA Out-gassing failure recovery	DELETED

7.3.2) Contingency Procedures:

7.3.2.1 Software Upload: OME_SWUPL

Software upload scenario description

After power on, OMEGA is controlled by the boot program that is stored in a ROM memory (read-only memory). It is in the Boot state and will remain in this state for 60 secs during nominal operations. In the Boot state, OMEGA can receive and store an “init” telecommand (see FUM). If several “init” TC are received, the last one will overwrite the previous one. At the end of the 60 secs, the boot program tests the content of the “init” TC. If that “init” TC (see FUM) is an Upload Initialization TC (with a specific datafield parameter 1B 00 NN NN that follows the validation parameter 3B 00 NN NN) , the Boot program retains control and OMEGA enters the “upload” state. For any other initialization TC, the Boot program loads the main program from the EEPROM and transfers control to the main program. In all cases, the end of the 60secs is indicated by the emission of the TM event “state change”.

In the upload state, only memory load TC’s, memory dump TC’s and other mandatory services (i.e. all services other than private TC services) will result in a “acknowledge success” by the instrument. OMEGA will remain in the upload state until switch-off.

The 16 bits field NN NN from the initialization TC indicates the number of expected memory TC’s (Service 6.2) that are needed to upload the whole program. Each of the memory load TC’s loads one block of 108 16-bits words (112 16-bits words in the data field) as 54 32-bits words in the RAM. The first start address is the base of the high memory (0x2000000). It

	MARS EXPRESS OMEGA EXPERIMENT FLIGHT USER MANUAL	Reference : OME-DU-0023-118-IAS Author : M. Berthé Edition : 3 Revision : 0 Rev. date : 15 May 2003 Page : 53
---	---	--

nominally increases by 64 for each successive memory load. These TCs can be sent to the instrument with any time interval longer than 0.025 seconds. For each successive memory load TC, the boot program checks whether the TC is valid. If not, an “acknowledge, failure” is issued. We request that the spacecraft resend the same memory load TC once in case of an “acknowledge, failure” response from OMEGA. If the memory load TC is valid, the Boot program checks whether the starting address is that expected (last + 64). If not, the event “upload, failure” is sent (see FUM). If NNNN memory load TC’s have been received, fully compliant to this protocol, then the Boot program overwrites the EEPROM with the NNNN x 108 x 2 bytes content of the NNNN memory load TC’s. At the end of the write, the event “upload, success” is issued.

After the reception of the Event report indicating the success of the Upload, the relevant content of the EEPROM should be dumped using the Memory Dump request service (service 6.5), with OMEGA generating Memory dump reports (service 6.6).

For each upload (test or actual), OMEGA will provide the ORS with the relevant initialization TC (private), the Memory Patch Request file and the Memory Dump Request file following the specifications in the CRID.

After completion of this upload sequence, the instrument is powered off, and has to be powered on again before the next observation.

Objective: Switch OMEGA instrument ON in it’s nominal configuration (ie all redundancies to the Nominal selection) , perform an complete EEPROM software upload, and switch the instrument OFF at completion

Origin: Ground

Initial Condition: OMEGA in OFF state

Duration for completion: 20 minutes

Final State: OMEGA in OFF state

	MARS EXPRESS OMEGA EXPERIMENT FLIGHT USER MANUAL	Reference : OME-DU-0023-118-IAS Author : M. Berthé Edition : 3 Revision : 0 Rev. date : 15 May 2003 Page : 54
---	---	--

Commands to be sent

Time from start of procedure (seconds)	Commands to be sent	Command verification	Comment
0	Pulse Command: OMENMECnON	RSS status OMENRSSMECn is ON	Select Nominal MEC board
5	Pulse Command: OMENPWON	RSS status OMENRSSPWR is ON and TM Event generation: Progress report: 5.1 EID number: 0xA412 (software change of state)	Close Main power Relay, ie Power ON
10	Pulse Command: OMENSKCOFF	RSS status OMENRSSSKC is OFF	Switch OFF SKC from nominal side
15	SCET time distribution to OMEGA (DMS command 9.2)	none	Send time to OMEGA
20	TC: OMEINIT (211.1) with 5 parameter (Uint32 format) : 3B 00 NN NN 00 00 00 00 00 00 00 00 00 00 00 00 1B 00 NN NN	Acceptance report TM 1.1	see parameter definition in 9.4.1.1. NN NN is the number of memory load TCs that will follow. NN NN = around 450d
65	none	TM Event generation: Progress report: 5.1 EID number: 0xA412 (software change of state):	transition from Boot to init state
115		TM Event generation: Progress report: 5.1 EID number: 0xA411 (end of init state):	transition from Init to Upload
repeat NN times at 200 + i * 2 seconds	Upload TC (6.2) with 112 16-bits words in the data field (108 data and 4 address)	Acceptance report 1.1	the 2 seconds time interval can be adjusted to fit DMS capability (OMEGA lower limit is 0.025 seconds)
10 seconds after last Upload TC		TM Event generation: Progress report: 5.1 EID number: 0xA413 (Upload success):	Upload performed: New software is now stored in EEPROM
20 seconds after last Upload TC	Pulse Command: OMENPWROFF	RSS status OMENRSSPWR is OFF	Open Main power Relay (redundant DPU channel)

	<p>MARS EXPRESS OMEGA EXPERIMENT FLIGHT USER MANUAL</p>	<p>Reference : OME-DU-0023-118-IAS Author : M. Berthé Edition : 3 Revision : 0 Rev. date : 15 May 2003 Page : 55</p>
---	---	---

7.4) Operational Constraints

7.4.1) In flight limitation:

Limited Life Item Constraints (identification, limits and monitoring)

There is a cumulative duration limit of operation on the coolers (2000 hours). It will be tracked by OMEGA team

7.4.2) On ground test limitation:

Limited Life Item Constraints (identification, limits and monitoring)

The limitation of the cryo coolers life time and the risk of detector freezing impose to respect the following conditions:

- 1- minimum duration between two consecutive switching-on sequences = 30 mn
1. maximum running time per sequence = 4 mn; this is implemented in order to avoid freezing of water vapor on the detectors. It is not applicable under vacuum. This limitation does not apply in flight.
- 2- maximum cumulated running time of the machines after the delivery of the flight models = 5 h

The working time will be indicated within the instrument booklet. The “instrument booklet” is a logbook kept during ground operation. It will among other things keep a log of the use of the coolers.

 MEX	MARS EXPRESS OMEGA EXPERIMENT FLIGHT USER MANUAL	Reference : OME-DU-0023-118-IAS Author : M. Berthé Edition : 3 Revision : 0 Rev. date : 15 May 2003 Page : 56
---	---	--

8) Summary of Telemetry and Telecommands

8.1) List of dangerous Commands

None.

NONE

 <p>Ω MEX</p>	<p>MARS EXPRESS OMEGA EXPERIMENT FLIGHT USER MANUAL</p>	Reference : OME-DU-0023-118-IAS Author : M. Berthé Edition : 3 Revision : 0 Rev. date : 15 May 2003 Page : 57
--	--	--

8.2) Summary of Telemetry and Telecommand packets

Sub Type	Service Request (TC)	Sub Type	Service Reports (TM)
SERVICE 1 Telecommand verification			
		1	Acceptance Acknowledge - Success
		2	Acceptance Acknowledge - Failure
SERVICE 3 Housekeeping Report			
5	Enable HK Report		
6	Disable HK Report		
		25	HK parameter Report
SERVICE 5 Event Report			
		1	Normal progress report
		2	Anomalous Event report
SERVICE 6 Memory Management			
2	Load Memory by absolute add		
5	Memory Dump request		
		6	Memory Dump by absolute address
SERVICE 9 Time Management			
1	Accept time update		
SERVICE 17 Test Service			
1	Connection Test Request		
		2	Connection Test Report
SERVICE 20 Science Data Transfer			
1	Enable Science Report (RTU)		
2	Disable Science Report (RTU)		
		3	Science Reporting (RTU)
10	Enable Science Report (HS)		
11	Disable Science Report (HS)		
		12	Report Science data generation (HS) stopped
		13	Science Reporting (HS)
SERVICE 211 Private TC Service			
1	Initialization TC		
2	Parameter TC		
3	Activity TC		
4	Cooler TC		
SERVICE 255 Common Payload Service			
1	Reset TM output buffer		
2	Reset SMCS		
3	Start HS Link		
4	Reset SMCS and Start HS Link		

	MARS EXPRESS OMEGA EXPERIMENT FLIGHT USER MANUAL	Reference : OME-DU-0023-118-IAS Author : M. Berthé Edition : 3 Revision : 0 Rev. date : 15 May 2003 Page : 58
---	---	--

8.3) Telemetry and telecommand parameters

8.3.1) Command Handling

8.3.1.1) Telecommand verification

Omega Telecommand reception from OBDH system is performed by an FPGA.

- Reception Timeout verification: performed by FPGA
 - If a complete TC packet (based on packet length defined in packet header) is not received within 2 seconds, this packet is discarded and TC buffer is reset.
 - A TM packet type (1.2) with failure code 1 should be generated
- packet APID is checked: TC first 2 bytes should always be 1D1C hex
 - If the packet ID is not valid (type =1, PID = 81, cat = 12), i.e. first 2 bytes not 1D1C hex, the packet is discarded and a TM packet type (1.2) with failure code 3 is generated
- CRC is checked
 - CRC16 value of the packet (all bytes including header, except 2 lasts) is calculated
 - CRC value of packet as sent (2 last Bytes) is compared to this values
 - If both CRC are different, a TM packet type (1.2) with failure code 2 is generated
- TC is handled according to its type and subtype fields
 - (3.5) Enable HK: set flag “HK_distrib”
 - (3.6) Disable HK: clear flag “HK_distrib”
 - (6.2) Load memory: receive a TC packet with up to 113 words of memory data. Data will remain stored in RAM until reception of complete EEPROM memory contents (290 of these TCs covers the whole Flight Software code in EEPROM). Upload TC can only be implemented in the upload state, i.e. if the initialization TC contained a validated “upload” TC element. Otherwise, an “incorrect TC” event is generated. An upload TC of each of the three sub-types (first, next, last) contains as many TC elements (4 bytes) as required by the length of the data field in the header. All TC elements are appended by the boot program to a RAM buffer which contains information to be written to the EEPROM. If all TC are validated by the CRC procedure, and if the “last upload” TC fills up the expected number of upload TC from the “upload” TC-element in the initialization, then the boot program overwrites the EEPROM with the content of the RAM buffer. Otherwise, the “upload mismatch” event is generated. No partial Upload of the program (ie patches are not possible)
 - (6.5) Memory dump request: will generate a TM packet (6.6) with contents of requested memory segment (up to 2044 words)
 - (9.1) Accept time update: time update TC from SC. Should be received every minute (very 8 BCPS)
 - (17.1) Connection test request: generates a TM connection report (17.2)
 - (20.1) Enable SC_RTU: set flag “SC_RTU_distrib”

 MEX	<p style="text-align: center;"> MARS EXPRESS OMEGA EXPERIMENT FLIGHT USER MANUAL </p>	Reference : OME-DU-0023-118-IAS Author : M. Berthé Edition : 3 Revision : 0 Rev. date : 15 May 2003 Page : 59
---	--	--

- (20.2) Disable SC_RTU: clear flag “SC_RTU_distrib”
- (20.10) Enable SC_HS: set flag “SC_HS_distrib”
- (20.11) Disable SC_HS: clear flag “SC_HS_distrib”
- (211.1) Omega Initialization TC
- (211.2) Omega Parameter TC
- (211.3) Omega Activity TC
- (211.4) Omega Command TC
- (255.1) reset TM output buffer
- else: TC (type.subtype) is invalid: a TM packet type (1.2) with failure code 4 is generated.
- if the TC is not detected as invalid before and if the acknowledge flag is set (in first byte of the TC datafield header): A acknowledge success TM packet, type (1.1) is generated.

NB: acknowledge flag should be set for all TC types except service 9 , 17 & 255

	MARS EXPRESS OMEGA EXPERIMENT FLIGHT USER MANUAL	Reference : OME-DU-0023-118-IAS Author : M. Berthé Edition : 3 Revision : 0 Rev. date : 15 May 2003 Page : 60
---	---	--

8.3.2) Data generation and formatting

8.3.2.1) Telemetry generated directly from a TC (solicited TM)

TM type listed below are generated directly on reception of a TC (and only by this way):

- (1.1) TC acknowledge success at reception of a valid TC with ack field set to 1.
- (1.2) TC acknowledge failure at reception of an invalid TC
- (6.6) Memory dump report at reception of a Dump request TC type (6.5)
- (17.2) Ping test report at reception of a Ping test request TC type (17.1)

The Pad field of these TM packet should be the copy of the Pad field of the TC packet
The Pad field for all other type of TM should be set to 0.

8.3.2.2) Event packets

Event packets are generated at every important step in the experiment progress

Normal progress events list:

See table in part 9.1.

Anomalous progress reports (warning only) list

See table in part 9.1.

8.3.2.3) Housekeeping Report Packets

Every 3,4 seconds during observation period.

8.3.2.4) Science Report Packets, High Speed Link

These packets will contain the exact copy of the TR (“Telemesure Rapide”) packets as defined for Mars 96. See RD 3, chapter 2.

8.3.2.5) Science Report Packets, RTU Link

These packets will contain the exact copy of the TL (“Telemesure Lente”) packets as defined for Mars 96. See RD 3, chapter 3-3.

	MARS EXPRESS OMEGA EXPERIMENT FLIGHT USER MANUAL	Reference : OME-DU-0023-118-IAS Author : M. Berthé Edition : 3 Revision : 0 Rev. date : 15 May 2003 Page : 61
---	---	--

8.4) Summary of software parameters

PID: 81 dec = 51h

81 to 85 for OMEGA (AD 1 , p. 225) => only 81 dec. is used

Private services (TC): service 211 only, subtypes 1 to 255 max.

211 to 215 for OMEGA (AD 1 , p.214)

Memory ID for OMEGA for Memory Load/Dump

= 192 dec. DM (32 bits)

= 193 dec. EEPROM (8 bits)

= 194 dec. PM (48 bits)

(AD 1 p. 88 updated) ID for OMEGA = 192 to 207

Packet categories used by OMEGA:

TM:

- 1 Acknowledge (service 1,1 & 1,2)
- 4 Housekeeping (service 3,25)
- 7 Event (service 5,1 & 5,2 & 17,2)
- 9 Dump (service 6,6)
- 12 Private (service 20)

TC: always

- 12 Private for all TCs received by OMEGA

Event ID (EID for Omega):

From 42001 to 42500 (decimal) (AD 1, p. 56)

Omega will use from 42001 (A411 hex) to 42200 (A4D8 hex) for Normal progress Events

Omega will use from 42201 (A4D9 hex) to 42500 (A604 hex) for Anomalous Events

	MARS EXPRESS OMEGA EXPERIMENT FLIGHT USER MANUAL	Reference : OME-DU-0023-118-IAS Author : M. Berthé Edition : 3 Revision : 0 Rev. date : 15 May 2003 Page : 63
---	---	--

In hex. format

```
Header:          0D 1a bb bb cc cc
data field
  data field Header  dd dd dd dd dd dd
                   e0 ff gg hh
Source data       .....
```

- a: packet category
 - 1 Acknowledge (service 1,1 & 1,2)
 - 4 Housekeeping (service 3,25)
 - 7 Event (service 5,1 & 5,2 & 17,2)
 - 9 Dump (service 6,6)
 - C Private (service 20)
- bb bb: TM packet count with 2 first bits set always to 1; from C0 00 (packet 0) to(FF FF (packet 16383) (cyclic 14 bit counter) by TM packet category
- cc cc: packet length = TM data field length in bytes - 1 ; max value = 4105
- dd dd dd dd dd dd: packet timestamp (in SCET time, 4 bytes seconds, 2 bytes subseconds)
- e: PUS version = 0 if private packet, 4 else
- ff: packet type
- gg: packet subtype
- hh: PAD field = 00 if unsolicited , soliciting TC PAD field else

Example: Service 17 (ping test)

TM: Connection test report; service: 17.2

packet category: Event ;	a = 7
TM number 1:	cb bb = C0 01
datafield length in byte = 10 + 0 = 10	cc cc = 00 09
SCET time = 12 34 56 78 00 00 (i.e.)	dd dd dd dd dd dd = 12 34 56 78 00 00
PUS = 4	e = 4
packet type = 17d	ff = 11
packet subtype = 2	gg = 02
PAD field for TC = 0 ie	hh = 00
no data field in this TM	

TM packet = 0D 17 C0 01 00 09 12 34 56 78 00 00 40 11 02 00

	MARS EXPRESS OMEGA EXPERIMENT FLIGHT USER MANUAL	Reference : OME-DU-0023-118-IAS Author : M. Berthé Edition : 3 Revision : 0 Rev. date : 15 May 2003 Page : 64
---	---	--

9.2) Telemetry structure by service types

9.2.1) TM Service 1, TC verification reports

9.2.1.1) Acceptance Acknowledge success

Packet in Hex:

Header: 0D 11 Cx xx 00 0D

Datafield hd: tt tt tt tt tt tt 40 01 01 00

Datafield: 1D 1C zz zz

With:

x xx: 14 bit counter of packet number in category 1

tt tt tt tt tt tt: SCET time

zz zz: copy of acknowledged TC Seq. control

Telemetry Packet Information			
Packet Name	OME_ACC_SUCCESS		Instrument: OMEGA
Packet Function	OMEGA Acceptance Acknowledge Success		
Generation Rules	After reception of a valid TC Packet (with Ack field = 1)		
Header Information			
Process ID	81d = 51h	Packet Category	1
Service Type	1	Service Subtype	1
Structure ID		Packet Length in Bytes	Datafield = 10 + 4 = 14 Total packet = 20
Data Field Information			
Data Field	Field Structure	Remark	
copy of TC packet ID	Uint16	full copy of acknowledged TC packet ID (16 bit field)	
copy of TC Seq. control	Uint16	full copy of acknowledged TC packet sequence control (16 bit field)	
Notes:			

	MARS EXPRESS OMEGA EXPERIMENT FLIGHT USER MANUAL	Reference : OME-DU-0023-118-IAS
		Author : M. Berthé Edition : 3 Revision : 0 Rev. date : 15 May 2003 Page : 65

9.2.1.2) Acceptance failure

Packet in Hex:

Header: 0D 11 Cx xx 00 15
Datafield hd: tt tt tt tt tt tt 40 01 02 00
Datafield: yy yy zz zz 00 aa bb cc dd dd ee ee

With:

x xx: 14 bit counter of packet number in category 1
tt tt tt tt tt tt: SCET time
yy yy: copy of TC packet ID; if the packet is for Omega = 1D 1C
zz zz: copy of TC Seq. control
00 aa : failure code
bb: param 1 Etc..

Telemetry Packet Information			
Packet Name	OME_ACC_FAILURE		Instrument: OMEGA
Packet Function	OMEGA Acceptance Failure Report		
Generation Rules	After reception of an invalid TC Packet		
Header Information			
Process ID	81d = 51h	Packet Category	1
Service Type	1	Service Subtype	2
Structure ID		Packet Length in Bytes	Datafield = 10 + 12 = 22 Total packet = 28
Data Field Information			
Data Field	Field Structure	Remark	
copy of TC packet ID	UInt16	full copy of acknowledged TC packet ID (16 bit field)	
copy of TC Seq. control	UInt16	full copy of acknowledged TC packet sequence control (16 bit field)	
Failure Code	UInt16	MSB , lsb , see note 1	
Param. 1	UInt8	See note 1	
Param. 2	UInt8	See note 1	
Param. 3	UInt16	See note 1	
Param. 4	UInt16	See note 1	
Notes:			

	MARS EXPRESS OMEGA EXPERIMENT FLIGHT USER MANUAL	Reference : OME-DU-0023-118-IAS Author : M. Berthé Edition : 3 Revision : 0 Rev. date : 15 May 2003 Page : 66
---	---	--

Note 1: failure code and parameter values

Failure Code	Failure name	Failure Reason	Param. 1 Uin8	Param. 2 Uin8	Par. 3 Uin16	Par 4 Uin16
1	ERR_TC_TIMEOUT	TC packet not complete after 2 seconds	TC packet Type	TC packet SubType	Nbr of expected Bytes (from TC Hd)	Nb of Bytes received in 2 sec
2	ERR_INCORRECT_CRC	Calculated CRC is not equal to CRC at end of TC packet	TC packet Type	TC packet SubType	CRC as read from packet datafield	CRC as calculated using TC data
3	ERR_INCORRECT_APID	TC packet has wrong APID (ID # 81d = 51h or Cat #12)	TC packet Type	TC packet SubType	0	0
4	ERR_INVALID_TC	tbd	TC packet Type	TC packet SubType	0	0
5	ERR_CAN_NOT_EXEC	can not execute TC at this time	TC packet Type	TC packet SubType	tbd	tbd
6	ERR_TC_DATAFIELD_ERROR	inconsistent data field	TC packet Type	TC packet SubType	tbd	tbd

	MARS EXPRESS OMEGA EXPERIMENT FLIGHT USER MANUAL	Reference : OME-DU-0023-118-IAS Author : M. Berthé Edition : 3 Revision : 0 Rev. date : 15 May 2003 Page : 67
---	---	--

9.2.2) TM Service 3, HK reporting

The Omega HK packet is a very simplified subset of the SC RTU data, defined in a fixed format.

Packet in Hex:

Header: 0D 14 Cx xx 00 3B

Datafield hd: tt tt tt tt tt tt 40 03 19 00

Datafield : 00 01 (PAD field and SID)

hk packet data

With:

x xx: 14 bit counter of packet number in category 4

tt tt tt tt tt tt: SCET time

	MARS EXPRESS OMEGA EXPERIMENT FLIGHT USER MANUAL	Reference : OME-DU-0023-118-IAS
		Author : M. Berthé
		Edition : 3
		Revision : 0
		Rev. date : 15 May 2003
		Page : 68

Telemetry Packet Information		
Packet Name	OME_HK_REP	Instrument: OMEGA
Packet Function	OMEGA Housekeeping parameter Report	
Generation Rules		
Header Information		
Process ID	81d = 51h	Packet Category : 4
Service Type	3	Service Subtype : 25
Structure ID		Packet Length in Bytes : Datafield = 10 + 50 = 60 Total packet = 18 + 50 = 68
Data Field Information		
Data Field	Field Structure	Remark
Pad field	Uint8	= 0
SID	Uint8	= 1
MEC_version	Uint16	Version number (including MECN/MECR status)
MEC_stat	Uint16	MEC status report
MEC_SEG_UART	Uint16	UART and SEG selection info
ME_4	Uint16	TL stac (nb de message dans TL stack)
ME_5	Uint16	ERR_TR : nb of cumulated errors from HR buffer
SEA_9	Uint16	OMEC ON/OFF status bit pattern
SEA_10	Uint16	SEA status bits
SKA_3	Uint16	Motor C Voltage (12 bit ADC)
SKA_4	Uint16	Motor C Current (12 bit ADC)
SKA_5	Uint16	Motor L Voltage (12 bit ADC)
SKA_6	Uint16	Motor L Current (12 bit ADC)
SEA_5	Uint16	+5V OMEC Voltage (12 bit ADC)
SEA_6	Uint16	+15V OMEC Voltage (12 bit ADC)
SEA_7	Uint16	-15V OMEC Voltage (12 bit ADC)
S0A_5	Uint16	Bloc C Detector Temperature (12 bit ADC)
S0A_6	Uint16	Bloc L Detector Temperature (12 bit ADC)
SOA_10	Uint16	190K part temperature (12 bit ADC)
SOA_11	Uint16	Bloc L Detector Temperature ZOOM (12 bit ADC)
SEP_1	Uint16	SEP Temperature (12 bit ADC)
SOA_1	Uint16	Spectro C1 temperature (12 bit ADC)
SOA_2	Uint16	Spectro C2 temperature (12 bit ADC)
SOA_3	Uint16	Spectro L1 temperature (12 bit ADC)
SOA_4	Uint16	Spectro L2 temperature (12 bit ADC)
PF_1	Uint16	Room stage temperature (12 bit ADC)
Notes: See parameter calibration “curse” hereafter		

	MARS EXPRESS OMEGA EXPERIMENT FLIGHT USER MANUAL	Reference : OME-DU-0023-118-IAS Author : M. Berthé Edition : 3 Revision : 0 Rev. date : 15 May 2003 Page : 69
---	---	--

MEC_version:

b15	b14	b13	b12	b11	b10	b09	b08	b07	b06	b05	b04	b03	b02	b01	b00
SEG_status				MEC board				Version				Sub version			

SEG_status

- 0 = SEG not OK
- 1 = SEG OK

MEC Board :

- 0 = MEC EM Board EM active
- 1 = MECn board FM1 Active
- 2 = MECr board FM1 Active
- 3 = MECn board FM2 Active
- 4 = MECr board FM2 Active
- 0

Version:

- Software version count (0 to 15d)

Sub Version:

- Software Sub-version count (0 to 15d)

MEC_stat: MEC status word

Bit	b15	b14	b13	b12	b11	b10	b09	b08	b07	b06	b05	b04	b03	b02	b01	b00
value =1	x	SEG B selected	RTU only	Nom Out UART	Nom In UART	IEEE IF Nom	x	x	MEC Status							
value =0	x	SEG A selected	IEEE TM	Red Out UART	Red In UART	IEEE IF Red	x	x								
std value	1	0	0	0	0	0	1	1								

with MEC status:

- 0x0 = Init
- 0x3 = Pre obs
- 0xC = 12d = Obs
- 0x18 = 24d = Outgassing
- 0x1B = 27d = Upload (Should not generate HK)
- 0xFF = 255d = Boot (Should not generate HK)

	MARS EXPRESS OMEGA EXPERIMENT FLIGHT USER MANUAL										Reference : OME-DU-0023-118-IAS
											Author : M. Berthé
											Edition : 3
											Revision : 0
											Rev. date : 15 May 2003
										Page : 70	

MEC_selection:

b15	b14	b13	b12	b11	b10	b09	b08	b07	b06	b05	b04	b03	b02	b01	b00
UART selection status								SEG selection status							

UART selection status:

- tbd

SEG selection status:

- 0 = Not selected Yet
- 0x60 = 96d = Selected
- 0x30 = 48d = Ready

SEG_autotest:

- 0x4F4C = ok (ASCII) = SEG autotest result correct
- 0x4C4F = ko (ASCII) = SEG autotest failed
- other: link problem

SEA_9: OMEC ON/OFF Status:

Bit	b15	b14	b13	b12	b11	b10	b09	b08	b07	b06	b05	b04	b03	b02	b01	b00
value =1	x	x	x	x	SEP27VA ON	SEP27VB ON	SEP27V ON	VEA ON	FEA_A ON	FEA_B ON	SKC_C ON	SKC_L ON	SEA_A ON	SEA_B ON	SES_C ON	SES_L ON
value =0	x	x	x	x	SEP27VA OFF	SEP27VB OFF	SEA27V OFF	VEA OFF	FEA_A OFF	FEA_B OFF	SKC_C OFF	SKC_L OFF	SEA_A OFF	SEA_B OFF	SES_C OFF	SES_L OFF
std value	0	0	0	0	1	0	1	1	1	0	0	0	1	1	1	1

SEA_10: SEA Status bit:

Bit	b15	b14	b13	b12	b11	b10	b09	b08	b07	b06	b05	b04	b03	b02	b01	b00
value =1	x	x	x	x	SWIR outgassing ON	SWIR outgassing Enabled	x	SOA cal Lamp ON	SOA Shutter OPEN	SOA Shutter CLOSED	FEA Mirror emergency Position	x	x	x	x	x
value =0	x	x	x	x	SWIR outgassing OFF	SWIR outgassing disabled	x	SOA Cal lamp OFF	SOA Shutter CLOSED	SOA Shutter OPEN	FEA Mirror Nominal Position	x	x	x	x	x
std value	0	0	0	0	0	0	0	0	0	1	0	0	0	0	0	0

SKA_3: Cryocooler C motor Voltage (analog)

- Calibration curve: Voltage (V) = 0.00686813 * SKA_3

SKA_4: Cryocooler C motor Current (analog)

- Calibration curve: Current (A) = 1.11 10⁻⁴ * SKA_4

SKA_5: Cryocooler L motor Voltage (analog)

	MARS EXPRESS OMEGA EXPERIMENT FLIGHT USER MANUAL	Reference : OME-DU-0023-118-IAS Author : M. Berthé Edition : 3 Revision : 0 Rev. date : 15 May 2003 Page : 71
---	---	--

- Calibration curve: Voltage (V) = 0.00686813 * SKA_3

SKA_5: Cryocooler L motor Current (analog)

- Calibration curve: Current (A) = 1.11 10⁻⁴ * SKA_4

SEA_5: +5V OMEC voltage (analog)

- Calibration curve: Voltage (V) = 1.75 10⁻³* SEA_5

SEA_6: +15V OMEC voltage (analog)

- Calibration curve: Voltage (V) = 5.05410⁻³* SEA_6

SEA_7: -15V OMEC voltage (analog)

- Calibration curve: Voltage (V) = - 4.76 10⁻³* SEA_7

SOA_5: Bloc C detector temperature (analog)

- Calibration curve:
 - R(Ohm) = 6.1689 + 0.032881257 * SOA_5
 - if R < 100 then T(°C) = -247.3 + 2.45846 * R
 - if R > 100 then T(°C) = -260.1 + 2.5983 * R

SOA_6: Bloc L detector temperature (analog)

- Calibration curve:
 - R(Ohm) = 5.96 + 0.032954 * SOA_6
 - if R < 100 then T(°C) = -247.3 + 2.45846 * R
 - if R > 100 then T(°C) = -260.1 + 2.5983 * R

SOA_10: 190K part temperature

- Calibration curve
 - R(Ohm) = -1.6489225 + 0.043741485 * SOA_10 -38.5
 - if R < 100 then T(°C) = -247.3 + 2.45846 * R
 - if R > 100 then T(°C) = -260.1 + 2.5983 * R

SOA_11: Bloc L temperature Zoom

- Calibration curve:
 - R(Ohm) = 0.84303 + 0.008096 * SOA_11 - 11.4
 - if R < 100 then T(°C) = -247.3 + 2.45846 * R
 - if R > 100 then T(°C) = -260.1 + 2.5983 * R

SEP_1: SEP Temperature

- Calibration curve: T(°C) = a0 + a1 * SEP_1 + a2 * SEP_1 ^2 + a3 * SEP_1 ^3
with:
 - a0 = 91.230588
 - a1 = -0.080989128
 - a2 = 2.623123 10⁻⁵
 - a3 = -3.8170701 10⁻⁹

	MARS EXPRESS OMEGA EXPERIMENT FLIGHT USER MANUAL	Reference : OME-DU-0023-118-IAS Author : M. Berthé Edition : 3 Revision : 0 Rev. date : 15 May 2003 Page : 72
---	---	--

SOA_1: Spectrometer C1 Temperature

- Calibration curve:
 - $R(\text{Ohm}) = -1.6657037 + 0.044027826 * \text{SOA}_1 - 26.3$
 - if $R < 100$ then $T(^{\circ}\text{C}) = -247.3 + 2.45846 * R$
 - if $R > 100$ then $T(^{\circ}\text{C}) = -260.1 + 2.5983 * R$

SOA_2: Spectrometer C2 Temperature

- Calibration curve:
 - $R(\text{Ohm}) = -3.1004596 + 0.044684458 * \text{SOA}_2 - 25.3$
 - if $R < 100$ then $T(^{\circ}\text{C}) = -247.3 + 2.45846 * R$
 - if $R > 100$ then $T(^{\circ}\text{C}) = -260.1 + 2.5983 * R$

SOA_3: Spectrometer L1 Temperature

- Calibration curve:
 - $R(\text{Ohm}) = -6.9684331 + 0.044001235 * \text{SOA}_3 - 45.6$
 - if $R < 100$ then $T(^{\circ}\text{C}) = -247.3 + 2.45846 * R$
 - if $R > 100$ then $T(^{\circ}\text{C}) = -260.1 + 2.5983 * R$

SOA_4: Spectrometer L1 Temperature

- Calibration curve:
 - $R(\text{Ohm}) = -1.4253 + 0.043950433 * \text{SOA}_4 - 47.55$
 - if $R < 100$ then $T(^{\circ}\text{C}) = -247.3 + 2.45846 * R$
 - if $R > 100$ then $T(^{\circ}\text{C}) = -260.1 + 2.5983 * R$

PF_1: Room stage Temperature

- Calibration curve: $T(^{\circ}\text{C}) = a_0 + a_1 * \text{SEP}_1 + a_2 * \text{SEP}_1^2 + a_3 * \text{SEP}_1^3$:
 - $a_0 = 91.148787$
 - $a_1 = -0.0809938$
 - $a_2 = 2.626938 \cdot 10^{-5}$
 - $a_3 = -3.815879 \cdot 10^{-9}$

	MARS EXPRESS OMEGA EXPERIMENT FLIGHT USER MANUAL	Reference : OME-DU-0023-118-IAS Author : M. Berthé Edition : 3 Revision : 0 Rev. date : 15 May 2003 Page : 73
---	---	--

9.2.3) TM Service 5, Event Reporting

9.2.3.1) Normal progress report

Packet in Hex:

Header: 0D 17 Cx xx 00 0B
Datafield hd: tt tt tt tt tt tt 40 05 01 00
Datafield: yy yy

With:

x xx: 14 bit counter of packet number in category 7
tt tt tt tt tt tt: SCET time
yy yy: Event ID (EID), starting from A4 11

Telemetry Packet Information			
Packet Name	OME_PROGRESS_REP	Instrument: OMEGA	
Packet Function	OMEGA Normal Progress Event report		
Generation Rules	After completion of important steps		
Header Information			
Process ID	81d = 51h	Packet Category	7
Service Type	5	Service Subtype	1
Structure ID		Packet Length in Bytes	Datafield = 10 + 2 = 12 Total packet = 12 + 6 = 18
Data Field Information			
Data Field	<i>Field Structure</i>	<i>Remark</i>	
EID	Uint16	EID number from 42001 to 42500 (see note 2)	
Notes:			

EID number (hex)	EID Name	Generation rule
0xA411	End of Init	Init state is over
0xA412	Software change of state	Generated at each state transition of the software, as described in state transition diagram
0xA413	Upload success	Generated at the end of a successful upload sequence
0xA416	Cryo cooler Switch ON	Generated at each switch ON of the cryo coolers
0xA417	Cryo cooler Switch OFF	Generated at each switch OFF of the cryo coolers



MEX

**MARS EXPRESS
OMEGA EXPERIMENT
FLIGHT USER MANUAL**

Reference : OME-DU-0023-118-IAS
Author : M. Berthé
Edition : 3
Revision : 0
Rev. date : 15 May 2003
Page : 74

	MARS EXPRESS OMEGA EXPERIMENT FLIGHT USER MANUAL	Reference : OME-DU-0023-118-IAS Author : M. Berthé Edition : 3 Revision : 0 Rev. date : 15 May 2003 Page : 75
---	---	--

9.2.3.2) Anomalous event report

Packet in Hex:

Header: 0D 17 Cx xx 00 0B

Datafield hd: tt tt tt tt tt tt 40 05 02 00

Datafield: yy yy

With:

x xx: 14 bit counter of packet number in category 7

tt tt tt tt tt tt: SCET time

yy yy: Event ID (EID), starting from A4 D9

Telemetry Packet Information			
Packet Name	OME_ANO_EVENT		Instrument: OMEGA
Packet Function	OMEGA anomalous event report (Warning)		
Generation Rules	After detection of an anomalous Event		
Header Information			
Process ID	81d = 51h	Packet Category	7
Service Type	5	Service Subtype	2
Structure ID		Packet Length in Bytes	Datafield = 10 + 2 = 12 Total packet = 12 + 6 = 18
Data Field Information			
Data Field	<i>Field Structure</i>	<i>Remark</i>	
EID	Uint16	EID number from 42100 to 42500 (see note 3)	
Notes:			

These events are only anomaly reports, no action has to be taken by S/C or ground on reception of these reports

EID number Hex format	EID Name	Generation rule
0xA414	Upload failure	Generated if one of the condition defined for a successful upload are not met. The whole uploaded software is NOT loaded in EEPROM
0xA415	Default init boot	Generated at end of init state if no valid init TC has been received. Instrument enter pre-obs state with default setting.

	MARS EXPRESS OMEGA EXPERIMENT FLIGHT USER MANUAL	Reference : OME-DU-0023-118-IAS Author : M. Berthé Edition : 3 Revision : 0 Rev. date : 15 May 2003 Page : 76

9.2.4) TM Service 6, Memory management

Telemetry Packet Information			
Packet Name	OME_MEMO_DUMP	Instrument: OMEGA	
Packet Function	OMEGA Memory dump Telemetry		
Generation Rules	After reception of a telemetry dump request TC		
Header Information			
Process ID	59	Packet Category	9 (Dump)
Service Type	6	Service Subtype	6
Structure ID		Packet Length in Bytes	Datafield = 10 + 8 + length *2 Total packet = 16 + 8 + length *2
Data Field Information			
Data Field	<i>Field Structure</i>	<i>Remark</i>	
Memory_ID	Uint8	Always 192 (dec) for OMEGA Memory	
N number of blocks	Uint8		
Start Address	Uint32	MSB to lsb	
Block length = n	Uint16	length in 16 bit words = n; n max = 2044	
Data	n Uint16	Dumped memory	
Notes: Only one valid Memory ID for OMEGA = 192 dec			
Only one memory segment can be dumped at each time			

Important Note : NCR : OME-NCR-FA-176 :

NCR Title: service 6.5 & 6.6 (Memory Dump report by absolute address) not handled in accordance with SGICD while OMEGA is in BOOT or UPLOAD state.

Description: (During specific Upload & Dump tests, it has been discovered that the OMEGA TM service 6.6 (Memory Dump report by absolute address) is not in accordance with SGICD while OMEGA is in BOOT or UPLOAD state.

The 2 first Bytes of the data field (Memory ID, always 192 and Number of Blocks, always 1) are missing in the telemetry packet.

Thus the first word of the Data Field is : Start address MSW.

In addition, the Number of Words sent in the TM is 3 less then in the requesting TC (service 6.5). Thus it is necessary to request 3 words more than the required dump packet will contain.

While in Pre-obs state, the OMEGA behaviour is fully in accordance with SGICD.

	MARS EXPRESS OMEGA EXPERIMENT FLIGHT USER MANUAL	Reference : OME-DU-0023-118-IAS Author : M. Berthé Edition : 3 Revision : 0 Rev. date : 15 May 2003 Page : 77
---	---	--

9.2.5) TM Service 17, Ping test report

Packet in Hex:

Header: 0D 17 Cx xx 00 09

Datafield hd: tt tt tt tt tt tt 40 11 02 00

With:

x xx: 14 bit counter of packet number in category 7

tt tt tt tt tt tt: SCET time

yy yy: Event ID (EID), starting from A4 11

Telemetry Packet Information			
Packet Name	OME_TEST_RESP		Instrument: OMEGA
Packet Function	OMEGA test report (ping test)		
Generation Rules	After reception of a TC test request		
Header Information			
Process ID	81d = 51h	Packet Category	7
Service Type	17	Service Subtype	2
Structure ID		Packet Length in Bytes	Datafield = 10 + 0 = 10 Total packet = 16
Data Field Information			
Data Field	<i>Field Structure</i>	<i>Remark</i>	
None			
Notes:			

	MARS EXPRESS OMEGA EXPERIMENT FLIGHT USER MANUAL	Reference : OME-DU-0023-118-IAS Author : M. Berthé Edition : 3 Revision : 0 Rev. date : 15 May 2003 Page : 78
---	---	--

9.2.6) TM Service 20, Science reporting

9.2.6.1) OMEGA Science Report in RTU channel

Omega Science packets in RTU channel is uses the same format as the TL data described in RD3, part 3-3.

Packet in Hex:

Header: 0D 1C Cx xx yy yy

Datafield hd: tt tt tt tt tt tt 00 14 03 00

Datafield: TRL datas

With:

x xx: 14 bit counter of packet number in category 12

yy yy: packet datafield including datafield header length in Byte -1)

tt tt tt tt tt tt: SCET time

Telemetry Packet Information			
Packet Name	OME_SCI_REP_SLOW		Instrument: OMEGA
Packet Function	OMEGA Science Report in RTU channel		
Generation Rules	In pre observation, every 128 seconds		
Header Information			
Process ID	81d = 51h	Packet Category	12
Service Type	20	Service Subtype	3
Structure ID		Packet Length in Bytes	Datafield = variable Total packet = variable
Data Field Information			
Data Field	<i>Field Structure</i>	<i>Remark</i>	
Omega94_TL	As per RD3 3-3	Variable length	
Notes:			
Max theoretical length is 1024 bytes, typical length is 300 bytes			

	MARS EXPRESS OMEGA EXPERIMENT FLIGHT USER MANUAL	Reference : OME-DU-0023-118-IAS Author : M. Berthé Edition : 3 Revision : 0 Rev. date : 15 May 2003 Page : 79
---	---	--

9.2.6.2) OMEGA Science HS Report is stopped at packet boundary

Packet in Hex:

Header: 0D 17 Cx xx 00 09

Datafield hd: tt tt tt tt tt tt 40 14 0C 00

With:

x xx: 14 bit counter of packet number in category 7

tt tt tt tt tt tt: SCET time

Telemetry Packet Information			
Packet Name	OME_SCI_GEN_STOPPED	Instrument: OMEGA	
Packet Function	OMEGA Science Reporting via HS link is stopped		
Generation Rules	at end of Omega observation, after transmission of last (20,13) packet to inform Mass memory to close Current file		
Header Information			
Process ID	81d = 51h	Packet Category	7 (event)
Service Type	20	Service Subtype	12
Structure ID		Packet Length in Bytes	Datafield = 10 + 0 = 10 Total packet = 10 + 6 = 16
Data Field Information			
Data Field	<i>Field Structure</i>	<i>Remark</i>	
none			
Notes: this TM packet is sent via RTU link			

	MARS EXPRESS OMEGA EXPERIMENT FLIGHT USER MANUAL	Reference : OME-DU-0023-118-IAS Author : M. Berthé Edition : 3 Revision : 0 Rev. date : 15 May 2003 Page : 80
---	---	--

9.2.6.3) OMEGA Science Report via HS link

Packet in Hex:

Header: 0D 1C Cx xx yy yy

Datafield hd: tt tt tt tt tt tt 00 14 0C 00

Datafield: TMR datas

With:

x xx: 14 bit counter of packet number in category 12

yy yy: packet datafield including datafield header length in Byte -1)

tt tt tt tt tt tt: SCET time

Telemetry Packet Information			
Packet Name	OME_SCI_REP_FAST	Instrument: OMEGA	
Packet Function	OMEGA Science Report in HS link		
Generation Rules			
Header Information			
Process ID	81d = 51h	Packet Category	12
Service Type	20	Service Subtype	13
Structure ID		Packet Length in Bytes	Datafield = 10 + 2048 = 2058 Total packet = 2058 + 6 = 2064
Data Field Information			
Data Field	<i>Field Structure</i>	<i>Remark</i>	
Omega TR block	4096 Bytes	As in Mars 94/96 Omega See layout in RD3, section 2	
Notes: this TM packets are sent via High Speed link			

 MEX	MARS EXPRESS OMEGA EXPERIMENT FLIGHT USER MANUAL	Reference : OME-DU-0023-118-IAS Author : M. Berthé Edition : 3 Revision : 0 Rev. date : 15 May 2003 Page : 82
---	---	--

In hex. format

```
Header:          1D 1C Ca aa bb bb
data field
  data field Header  1y cc dd 00
  Source data       .....
  CRC               ee ee
```

- a aa: TC packet count from 0 to 2047 (cyclic 11 bit counter)
- bb bb: packet length = TC data field length in bytes - 1 ; max value is 241
- y: acknowledge; y = 0 no ack ; lsb of y = 1 ack TM message required
- cc: packet type
- dd: packet subtype
- ee ee: CRC as per AD 1

Exemple: Service 17 (ping test)

TC: Connection test request; service: 17.1

```
TC number 1:          a aa = 0 01
datafield length in byte = 4 + 0 + 2 = 6      bb bb = 00 05
no acknowledge required  y = 0
packet type = 17      cc = 11
packet subtype = 1    dd = 01
CRC for this packet   xx xx
```

TC packet = 1D 1C C0 01 00 05 10 11 01 00 xx xx

	MARS EXPRESS OMEGA EXPERIMENT FLIGHT USER MANUAL	Reference : OME-DU-0023-118-IAS Author : M. Berthé Edition : 3 Revision : 0 Rev. date : 15 May 2003 Page : 83
---	---	--

9.4) Telecommand Structure

9.4.1) OMEGA private TCs; Service 211

9.4.1.1) Initialization TC

Packet in Hex:

Header: 1D 1C Cx xx 00 19

Datafield hd: 11 D3 01 00

Source data	02 XX XX XX	configuration TC element (mandatory)
	05 XX XX XX	spectrometer element (optional)
	0A XX XX XX	cooling element (optional)
	3Y XX XX XX	validation of initialization TC element (optional)
	1Y XX XX XX	initialization TC element (mandatory)

CRC: ZZ ZZ

With

x xx: 12 bit counter of TC packet number

ZZ ZZ: CRC field

Telecommand Packet Information			
Packet Name	OMEINIT		Instrument: OMEGA
Packet Function	OMEGA initialization TC		
Generation Rules	to be sent less then 90 sec after instrument switch-on		
Header Information			
Process ID	81d = 51h	Packet Category	12
Service Type	211	Service Subtype	1
Structure ID		Packet Length in Bytes	Datafield = 4 + 20 + 2 = 26 Total packet length = 26 + 6 = 32
Data Field Information			
Data Field	<i>Field Structure</i>	<i>Remark</i>	
Data field Header	Uint32	4 Bytes, as per PID A; value in hex = 11 D3 01 00	
Configuration element	Uint32	see below	
Spectrometer element	Uint32	see below	
Cooling element	Uint32	see below	
Validation element	Uint32	see below	
Initialization element	Uint32	see below	
Packet Error Control	Uint16	CRC16 of the TC	
Notes:			

	MARS EXPRESS OMEGA EXPERIMENT FLIGHT USER MANUAL	Reference : OME-DU-0023-118-IAS Author : M. Berthé Edition : 3 Revision : 0 Rev. date : 15 May 2003 Page : 84
---	---	--

The Initialization TC is sent more than 1 sec and less than 60 sec after switch-on. It contains 5 TC elements. Two of the TC elements are mandatory, three are optional. If a non mandatory TC element is not present, it must be replaced by a NOP (00 00 00 00) TC element.

- 02 XX XX XX: configuration TC element (mandatory)
- 05 XX XX XX: spectrometer element (optional)
- 0A XX XX XX: cooling element (optional)
- 3Y XX XX XX: validation of initialization TC element (optional)
- 1Y XX XX XX: initialization TC element (mandatory)

A validation is a TC element with the same first byte as the TC it validates, but with bit 30 set. A validation is required for a “risky” initialization TC element, in particular outgassing and upload

After 60 sec, control is transferred by the boot program to the main program loaded from EEPROM, and OMEGA goes to the initialization state, unless the initialization TC is an upload. In the latter case, OMEGA goes to the upload state after 60 sec. In the upload state, only upload TC are implemented.

The initialization TC is activated after 110 sec. If no initialization has been received, the default initialization is activated. If several valid initialization TC are received before the 60 sec limit, only the last received is activated.

Activation of the initialization TC transfers from the initialization state to the pre-observation state, unless the initialization is an outgassing, in which case OMEGA goes to the outgassing state (no TC is implemented).

Initialization TC element: 1Y XX XX XX

- 18 XX XX XX: outgassing, a validation (38 XX XX XX) must be received before.
- 1A XX XX XX: Simplified control:coolers are started 2 minutes after OMEGA, for 4 minutes.
- 1B NN NN NN: upload, must follow a validation (3B XX XX XX) only upload TC are accepted once in upload state NN NN NN indicates the number of expected upload TC’s.
- 1D XX YY ZZ: test cooler operation is defined in minutes, not half hours
XX duration
YY time to start cooling
ZZ
- 1E XX XX XX: nominal cooler operation is defined in half hours

Configuration TC element: 02 XX XX XX

param value: 02 xx xx xx (triplicated byte)

	MARS EXPRESS OMEGA EXPERIMENT FLIGHT USER MANUAL	Reference : OME-DU-0023-118-IAS
		Author : M. Berthé Edition : 3 Revision : 0 Rev. date : 15 May 2003 Page : 85

bit num	7 (MSB)	6	5	4	3	2	1	0 (lsb)
param	x	SEG	TM output	UART Out Sel	UART In Sel	1355 channel	x	x
values	1	0 = A 1 = B	0 = HR 1 = Sec.	0 = Nom 1 = Red	0 = Nom 1 = Red	0 = Nom 1 = Red	1	1

- default is : 02 83 83 83 (SEG A, 1355 Nom, UART In & Out Nom)
- SEG B test: 02 C3 C3 C3
- IEEE 1355 redundant side test: 02 87 87 87
- TM RTU Only test (“mode secours”): 02 A3 A3 A3
- Redundant UART lines: 02 9B 9B 9B

The default value of this element is: 02 83 83 83 (SEG A, nominal telemetry, primary communication lines to and from the spectrometer)

Spectrometer TC element: 05 XX XX XX

The third byte (positions 24 to 17) contains selection bits for the control lines of the coolers and other critical elements of the spectrometer. The LSByte (positions 7 to 0) contain inhibit bits for each of the spectrometer subsystems: coolers C and L, Visible channel (VEA), SWIR-C and SWIR-L IR channels, scanning mirror. The middle byte contains information relevant to the observations. The spectrometer TC element can be sent in either the initialization TC or a parameter TC (see 4.)

Cooling parameter TC element: 0A XX XX XX

The cooling parameter TC element contains the required information to use different cooling parameters for the cryocoolers of the C and L IR channels, updating the default values. When it is used (special bit setting in the initialization TC element), an additional byte with cooling parameter information is located as the LSByte of the initialization TC. If no cooling parameter element has been validated, and the specific setting of the initialization TC element is used, the default values are sent to the spectrometer. The Cooling parameter TC element can be sent in either the initialization TC or a cooler control TC.

	MARS EXPRESS OMEGA EXPERIMENT FLIGHT USER MANUAL	Reference : OME-DU-0023-118-IAS Author : M. Berthé Edition : 3 Revision : 0 Rev. date : 15 May 2003 Page : 86
---	---	--

9.4.1.2) Parameter TC

Packet in Hex:

```
Header:      1D 1C Cx xx 00 19
Datafield hd: 11 D3 02 00
Source data  03 XX XX XX      Compression element
              04 XX XX XX      Observation element
              05 XX XX XX      spectrometer element
              06 XX XX XX      calibration lamp element
              07 XX XX XX      IR detector element
```

CRC: ZZ ZZ

With

x xx: 12 bit counter of TC packet number

ZZ ZZ: CRC field

Telecommand Packet Information			
Packet Name	OMEPARAM	Instrument: OMEGA	
Packet Function	OMEGA Parameter TC		
Generation Rules	allowed in test, simplified control & nominal sessions		
Header Information			
Process ID	81d = 51h	Packet Category	12
Service Type	211	Service Subtype	2
Structure ID		Packet Length in Bytes	Datafield = 4 + 20 + 2 = 26 Total packet length = 26 + 6 = 32
Data Field Information			
Data Field	<i>Field Structure</i>	<i>Remark</i>	
Data field Header	Uint32	4 Bytes, as per PID A; value in hex = 11 D3 02 00	
Compression TC element	Uint32	MSB is always 03	
Observation TC element	Uint32	MSB is always 04	
Spectrometer TC element	Uint32	MSB is always 05	
Cal_lamp TC element	Uint32	MSB is always 06	
IR_detector TC element	Uint32	MSB is always 07	
Packet Error Control	Uint16	CRC16 of the TC	
Notes: If an element is not need, it is replaced by a NOP TC element (00 00 00 00)			

	<p style="text-align: center;">MARS EXPRESS OMEGA EXPERIMENT FLIGHT USER MANUAL</p>	Reference : OME-DU-0023-118-IAS
		Author : M. Berthé Edition : 3 Revision : 0 Rev. date : 15 May 2003 Page : 87

If an element is not needed it should be replaced by 00 00 00 00

TC param: Compression element: 03 xx xx xx

xx = 00 : data are not compressed at all

b7	b6	b5	b4	b3	b2	b1	b0
1 = simulated 0 = cam	1 = No dark subtract 0 = Dark subtract	ibr					

ibr = 0: no compression (bit packing)
ibr = 1 = reversible compression
ibr = 2 to 63: compression factor: 16/ibr bits per data

standard value is : ibr = 8 (2 bit per data)

If b7 is set, the data collected from the OMEC at each interrupt are replaced by simulated data.

standard value: 03 08 08 08

TC param: Observation element: 04 xy abcd

- xy: Mode SWIR

SWIR Observation modes

parameter x 4 MSB		L	S	Tc	Tl	MVIS
0	n/a					
1	MIR1	16	1	2,5	2,5	31 to 38
2	MIR2	"	1	5	5	31 to 38
3	MIR3	32	1	2,5	2,5	19 to 30
3	MIR4	"	1	5	5	19 to 30
5	MIR5	64	1	2,5	2,5	7 to 18,39,40
6	MIR6	"	1	5	5	7 to 18,39,40
7	MIR7	128	1	2,5	2,5	1 to 6
		"	2	"	"	"
		"	3	"	"	"
		"	4	"	"	"
8	MIR8	128	1	5	5	1 to 6
		"	2	"	"	"
		"	3	"	"	"
		"	4	"	"	"
9	MIR9	128	1	10	10	4 to 6
		"	2	"	"	4 to 6

	MARS EXPRESS OMEGA EXPERIMENT FLIGHT USER MANUAL		Reference : OME-DU-0023-118-IAS
			Author : M. Berthé
			Edition : 3
			Revision : 0
			Rev. date : 15 May 2003
			Page : 88

A	MIR10	128	1	20	10	4 to 6
---	-------	-----	---	----	----	--------

With

L: Width of the path

S: Summing factor from path to path

Tc: integration time channel SWIRC

Tl: integration time channel SWIRL

MVIS: possible visible modes compatible with selected VNIR

parameter y value	Name	Number of spectral channels SWIRC et SWIRL	Operation
0	TSIR0	128	Transmission
2	TSIR1	64	Sommation
4	TSIR2	TBD	NA
6	TSIR3	TBD	NA
8	TSIR4	TBD	NA
A	TSIR5	TBD	NA
C	TSIR6	TBD	NA
E	TSIR7	TBD	NA

- yy zz: Mode VNIR*

yy zz bit pattern from bit 15 (MSB) to bit 0 (LSB)

Bit 15 & bit 14: 0 0: Spatial summming ME: x 1

0 1: Spatial summming ME: x 2

1 1: Spatial summming ME: x 4

Bits 13 to 8 (6 bit number, from 0 to 63)

value from 0 to 40: VIS mode number , ie 001101 means VIS13

value 41 to 63: not valid

Bits 7 to 5 (3 bit number, from 0 to 7)

value means: TSV table number

Bits 4,3,2 & 0: not affected

Bit 1: VNIR Gain selection (1 = high / 0 = low)



**MARS EXPRESS
OMEGA EXPERIMENT
FLIGHT USER MANUAL**

Reference : OME-DU-0023-118-IAS
 Author : M. Berthé
 Edition : 3
 Revision : 0
 Rev. date : 15 May 2003
 Page : 89

MVIS Mode table

	K	N	c	d	e	mode	T	Σ MV	MIR
MVIS1	32	384	8,8°	6	1	1	200	2	7/8
MVIS2	"	"	"	"	"	1	100	2	"
MVIS3	"	"	"	"	"	1	50	2	"
MVIS4	96	128	8,8°	3	3	1	200	2	7/8
MVIS5	"	"	"	"	"	1	100	2	"
MVIS6	"	"	"	"	"	1	50	3	"
MVIS7	96	64	4,4°	3	3	1	200	1	5/6
MVIS8	"	"	"	"	"	1	100	1	"
MVIS9	"	"	"	"	"	1	50	2	"
MVIS10	144	64	4,4°	2	3	1	200	1	5/6
MVIS11	"	"	"	"	"	1	100	1	"
MVIS12	"	"	"	"	"	1	50	1	"
MVIS13	96	64	8,8°	3	6	1	200	1	5/6
MVIS14	"	"	"	"	"	1	100	1	"
MVIS15	"	"	"	"	"	1	50	1	"
MVIS16	144	64	8,8°	2	6	1	200	1	5/6
MVIS17	"	"	"	"	"	1	100	1	"
MVIS18	"	"	"	"	"	1	50	1	"
MVIS19	96	32	2,2°	3	3	2	200	1	3/4
MVIS20	"	"	"	"	"	1	100	1	"
MVIS21	"	"	"	"	"	1	50	1	"
MVIS22	144	32	2,2°	2	3	2	200	1	3/4
MVIS23	"	"	"	"	"	1	100	1	"
MVIS24	"	"	"	"	"	1	50	1	"
MVIS25	96	32	4,4°	3	6	2	200	1	3/4
MVIS26	"	"	"	"	"	1	100	1	"
MVIS27	"	"	"	"	"	1	50	1	"
MVIS28	144	32	4,4°	2	6	2	200	1	3/4
MVIS29	"	"	"	"	"	1	100	1	"
MVIS30	"	"	"	"	"	1	50	1	"
MVIS31	96	16	1,1°	3	3	2	100	1	1/2
MVIS32	"	"	"	"	"	1	50	1	"
MVIS33	144	16	1,1°	2	3	2	100	1	1/2
MVIS34	"	"	"	"	"	1	50	1	"
MVIS35	96	16	2,2°	3	6	2	100	1	1/2
MVIS36	"	"	"	"	"	1	50	1	"
MVIS37	144	16	2,2°	2	6	2	100	1	1/2
MVIS38	"	"	"	"	"	1	50	1	"
MVIS39	144	64	1,4°	2	1	1	100	1	5/6
MVIS40	"	"	"	"	"	1	50	1	"

K: Number of lines (spectral elements) per images
 N: Number of columns (spatial elements) per image
 c: angular width of a scan
 d: line binning factor (spectral binning)
 e: column binning factor (spatial binning)
 mode: CCD mode
 T: Integration time (ms)
 Σ : facteur de sommation des images
 MIR: modes MIR possibles associés au mode VNIR

	MARS EXPRESS OMEGA EXPERIMENT FLIGHT USER MANUAL	Reference : OME-DU-0023-118-IAS
		Author : M. Berthé
		Edition : 3
		Revision : 0
		Rev. date : 15 May 2003
		Page : 90

TC param: Spectrometer element: 05 xx yy zz

xx: SEA ON/OFF configuration byte

bit num	7 (MSB)	6	5	4	3	2	1	0 (lsb)
param	Cryo C regulation temp det.	Outgassing temp detector	FEA/VEA command channel	FEA HK channel	Cryo L regulation temp det.	FEA	clock generator	x
values	0 = C 1 = L	0 = C 1 = L	0 = Nom 1 = Red	0 = Nom 1 = Red	0 = L 1 = C	0 = A 1 = B	0 = A 1 = B	0

default value is: 00

yy:

bit num	7 (MSB)	6	5	4	3	2	1	0 (lsb)
param								
values								

default value is: 00

zz: SEA enable/disable bit pattern

bit num	7 (MSB)	6	5	4	3	2	1	0 (lsb)
param	VNIR	FEA	SKCC	x	SESC	Shutter	SESL	SKCL
values	0=disable 1=enable	0=disable 1=enable	0=disable 1=enable	0	0=disable 1=enable	0=disable 1=enable	0=disable 1=enable	0=disable 1=enable

default value is: EF

- Redundant FEA test: param TC with parameter 05 04 00 EF

TC param: Calibration Lamp element: 06 xx yy zz

TC param: IR detector element: 07 xx yy zz

	MARS EXPRESS OMEGA EXPERIMENT FLIGHT USER MANUAL	Reference : OME-DU-0023-118-IAS Author : M. Berthé Edition : 3 Revision : 0 Rev. date : 15 May 2003 Page : 91
---	---	--

9.4.1.3) Activity TC

Packet in Hex:

Header: 1D 1C Cx xx 00 09
Datafield hd: 11 D3 03 00
Source data 1Y XX XX XX Activity element
CRC: ZZ ZZ

With

x xx: 12 bit counter of TC packet number
ZZ ZZ: CRC field

Telecommand Packet Information			
Packet Name	OME_ACTIVITY	Instrument: OMEGA	
Packet Function	OMEGA Activity TC		
Generation Rules	allowed in test, simplified control & nominal sessions		
Header Information			
Process ID	81d = 51h	Packet Category	12
Service Type	211	Service Subtype	3
Structure ID		Packet Length in Bytes	Datafield = 4 + 4 + 2 = 10 Total packet length = 10 + 6 = 16
Data Field Information			
Data Field	<i>Field Structure</i>	<i>Remark</i>	
Data field Header	Uint32	4 Bytes, as per PID A; value in hex =11 D3 03 00	
parameter n° 1	Uint32	Activity parameter (see table below)	
Packet Error Control	Uint16	CRC16 of the TC	
Notes:			

	MARS EXPRESS OMEGA EXPERIMENT FLIGHT USER MANUAL	Reference : OME-DU-0023-118-IAS Author : M. Berthé Edition : 3 Revision : 0 Rev. date : 15 May 2003 Page : 92
---	---	--

Activity parameter table

An activity TC is constituted of a single TC element. The following are valid values:

- 11 00 00 00: “START” TC element, initiates an observation with the current parameter table.
- 15 FF FF FF: “STAND-BY” TC element, suspends acquisition
- 11 FF FF FF: “RESUME” TC element, restarts acquisition after a “STAND-BY”
- 15 00 00 00: “STOP” TC element, stops acquisition
- 13 XX XX XX: “SUMMING” TC element, modifies spatial summing
- 17 XX XX XX: “ORDER” TC element, used only during ground tests, allow specific orders to be given to MEC or SEG (spectrometer).

TCs 17 xx yy zz = “ORDER” TC element, used only during ground tests, allow specific orders to be given to MEC or SEG (spectrometer).

Format: 17 xx yy zz

xx: MEI field

- 00: Configuration unchanged
- N/A for Mex

yy: MEG field

- 00: Configuration unchanged
- 80: Send a simulated TC packet on IEEE1355 link (426 bytes)
- E0: start of simulated data mode 1, without a OMEC
- FE: stop of simulated data mode 1, without a OMEC

zz: SEG field

- 00: Configuration unchanged
- 05: Forced stop of camera subsystems
- E4: Forced start of cryo coolers
- E5: Stop VEA
- E6: Stop FEA
- E7: Stop SES C
- E8: Stop SES L

 MEX	<p style="text-align: center;"> MARS EXPRESS OMEGA EXPERIMENT FLIGHT USER MANUAL </p>	Reference : OME-DU-0023-118-IAS Author : M. Berthé Edition : 3 Revision : 0 Rev. date : 15 May 2003 Page : 93
---	--	--

- E9: Stop of the cryo coolers
- EA: Stop decontamination mode
- D0: Start of forced close shutter
- D1: SWIR calib souce at level 1
- D2: SWIR calib souce at level 2
- D3: SWIR calib souce at level 3
- D4: SWIR calib souce at level 4
- D5: SWIR calib souce at level 5
- D6: SWIR calib souce OFF
- D7: End of forced close shutter
- FE: FEA soft reset

17 00 80 00: Send a simulated TC packet on IEEE1355 link (426 bytes)

17 00 E3 00: Simulated data mode start (to be sent before start of an observation, acquired data will be replaced by simulated one)

17 00 00 E4: Forced start of cryo coolers (only active once per sequence)

17 00 00 E9: Stop of the cryo coolers

	MARS EXPRESS OMEGA EXPERIMENT FLIGHT USER MANUAL	Reference : OME-DU-0023-118-IAS Author : M. Berthé Edition : 3 Revision : 0 Rev. date : 15 May 2003 Page : 94
---	---	--

9.4.1.4) Cooler control TC

Packet in Hex:

Header: 1D 1C Cx xx 00 0D

Datafield hd: 11 D3 04 00

Source data 0A XX XX XX Cooler parameter (optional)

14 XX XX XX Cooler TC element

CRC: ZZ ZZ

With

x xx: 12 bit counter of TC packet number

ZZ ZZ: CRC field

Telecommand Packet Information			
Packet Name	OME_COOLER		Instrument: OMEGA
Packet Function	OMEGA Command TC (Restricted use)		
Generation Rules	allowed in test, simplified control & nominal sessions		
Header Information			
Process ID	81d = 51h	Packet Category	12
Service Type	211	Service Subtype	4
Structure ID		Packet Length in Bytes	Datafield = 4 + 8 + 2 = 14 Total packet length = 14 + 6 = 20
Data Field Information			
Data Field	<i>Field Structure</i>	<i>Remark</i>	
Data field Header	UInt32	4 Bytes, as per PID A; value in hex = 11 D3 04 00	
Cooler parameter	UInt32	command parameter (see below)	
Cooler TC element	UInt32	command parameter (see below)	
Packet Error Control	UInt16	CRC16 of the TC	
Notes:			

A cooler control TC is constituted of two TC elements: the cooling parameter TC element (optional) and a specific activity TC element, the cooler TC element. If the cooling parameter is not present, it is replaced by a “NOP” TC element.

0A XX XX XX: cooling parameter TC element (optional)

14 XX XX XX: cooler TC element

 MEX	<p style="text-align: center;"> MARS EXPRESS OMEGA EXPERIMENT FLIGHT USER MANUAL </p>	Reference : OME-DU-0023-118-IAS Author : M. Berthé Edition : 3 Revision : 0 Rev. date : 15 May 2003 Page : 95
---	--	--

When a Cooler control TC is received, the relevant information from the cooling parameter TC element (if present) and the cooler TC element is sent to the spectrometer, so as to implement a change in the control of the cooler.

	MARS EXPRESS OMEGA EXPERIMENT FLIGHT USER MANUAL	Reference : OME-DU-0023-118-IAS Author : M. Berthé Edition : 3 Revision : 0 Rev. date : 15 May 2003 Page : 96
---	---	--

9.4.2) TC service 3, Enable / Disable HK reporting

9.4.2.1) Enable HK reporting

Packet in Hex:

Header: 1D 1C Cx xx 00 07
Datafield hd: 11 03 05 00
Source data: 00 01
CRC: ZZ ZZ

With

x xx: 12 bit counter of TC packet number

ZZ ZZ: CRC field

Telecommand Packet Information			
Packet Name	OME_ENABLE_HK	Instrument: OMEGA	
Packet Function	enable HK reporting from OMEGA		
Generation Rules			
Header Information			
Process ID	81d = 51h	Packet Category	12
Service Type	3	Service Subtype	5
Structure ID		Packet Length in Bytes	Datafield = 4 + 2 + 2 = 8 Packet = 8 + 6 = 14
Data Field Information			
Data Field	<i>Field Structure</i>	<i>Remark</i>	
Data field Header	UInt32	as per MEX SGIDB value in hex: 11 03 05 00	
PAD	UInt8	Pad field (no effect)	
SID	UInt8	HK structure identifier to be enabled (always 01)	
Packet Error Control	UInt16	CRC16 of the TC	

	MARS EXPRESS OMEGA EXPERIMENT FLIGHT USER MANUAL	Reference : OME-DU-0023-118-IAS Author : M. Berthé Edition : 3 Revision : 0 Rev. date : 15 May 2003 Page : 97
---	---	--

9.4.2.2) Disable HK reporting

Packet in Hex:

Header: 1D 1C Cx xx 00 07

Datafield hd: 11 03 06 00

Source data: 00 01

CRC: ZZ ZZ

With

x xx: 12 bit counter of TC packet number

ZZ ZZ: CRC field

Telecommand Packet Information			
Packet Name	OME_DISABLE_HK	Instrument: OMEGA	
Packet Function	disable HK reporting from OMEGA		
Generation Rules			
Header Information			
Process ID	81d = 51h	Packet Category	12
Service Type	3	Service Subtype	6
Structure ID		Packet Length in Bytes	Datafield = 4 + 2 + 2 = 8 Packet = 8 + 6 = 14
Data Field Information			
Data Field	<i>Field Structure</i>	<i>Remark</i>	
Data field Header	UInt32	as per MEX SGIDB value in hex: 11 03 06 00	
PAD	UInt8	Pad field (no effect)	
SID	UInt8	HK structure identifier to be disabled (always 01)	
Packet Error Control	UInt16	CRC16 of the TC	

	MARS EXPRESS OMEGA EXPERIMENT FLIGHT USER MANUAL	Reference : OME-DU-0023-118-IAS
		Author : M. Berthé Edition : 3 Revision : 0 Rev. date : 15 May 2003 Page : 98

9.4.3) TC service 6, Memory management

9.4.3.1) Memory load by absolute address

Upload TC can only be implemented in the upload state, i.e. if the initialization TC contained a validated “upload” TC element. Otherwise, an “incorrect TC” report is generated. In this state, OMEGA is controlled by the boot program that is stored in a ROM memory (read-only memory).

In this Upload state, only Upload TC’s and mandatory services are accepted by the instrument.

The instrument will await the number of Upload TCs as defined in the parameter of the init TC received before. All the Memory load data’s received during this period are stored in the RAM upper part until reception of the whole set of blocks corresponding to the EEPROM code. Once all the TCs are received and upon reception of a confirmation TC (Upload TC to a specific predefined address), the whole new program will be loaded into the EEPROM. The number of valid blocks is checked with respect to that indicated in the init TC, and a specific Event report is generated after successful completion of the EEPROM upload.

All the other states defined below are executed from the program contained in this EEPROM. In case of failure to get the whole program (CRC error in TCs, missing TC, no validation TC), the program is not uploaded and an anomalous event report is generated

Telecommand Packet Information			
Packet Name	OME_MEMO_PATCH	Instrument: OMEGA	
Packet Function	OMEGA Memory Patch TC		
Generation Rules	To be used to update flight software		
Header Information			
Process ID	81d = 51h	Packet Category	12
Service Type	6	Service Subtype	2
Structure ID		Packet Length in Bytes	datafield: $4 + 8 + 2*n + 2 = 14 + 2*n$ packet: $20 + 2 * n$
Data Field Information			
Data Field	<i>Field Structure</i>	<i>Remark</i>	
Data field Header	UInt32	as per MEX SGIDB value in hex: 11 06 02 00	
Memory_ID	UInt8	Always 192 (dec) for OMEGA Memory	
number of blocks	UInt8	Always 1 for OMEGA	
Start Address	UInt32	start address of segment to be uploaded	
Block length = n	UInt16	MSB lsb, length in 16 bit words = n (n maximum value is 113)	
Data	n UInt16	Data to be written in memory	
Packet Error Control	UInt16	CRC16 of TC	
Notes: Only one valid Memory ID for OMEGA = 192 dec			

	MARS EXPRESS OMEGA EXPERIMENT FLIGHT USER MANUAL	Reference : OME-DU-0023-118-IAS Author : M. Berthé Edition : 3 Revision : 0 Rev. date : 15 May 2003 Page : 99
---	---	--

9.4.3.2) Memory dump request by absolute address

Telecommand Packet Information		
Packet Name	OME_MEMO_DUMP_REQ	Instrument: OMEGA
Packet Function	OMEGA Memory dump request TC	
Generation Rules	To be used to dump a segment of flight software	
Header Information		
Process ID	81d = 51h	Packet Category 12
Service Type	6	Service Subtype 5
Structure ID		Datafield Length = 4 + 8 + 2 = 14 Total packet = 6 + 14 = 20
Data Field Information		
Data Field	<i>Field Structure</i>	<i>Remark</i>
Data field Header	UInt32	as per MEX SGIDB value in hex: 11 06 05 00
Memory_ID	UInt8	Always 192 (dec) for OMEGA Memory
number of blocks	UInt8	Always 1 for OMEGA
Start Address	UInt32	MSB to lsb , start address of segment to be dumped
Block length = n	UInt16	MSB lsb, length in 16 bit words = n (n maximum value is 2044)
Packet Error Control	UInt16	CRC16 of TC
Notes: Only one valid Memory ID for OMEGA = 192 dec Only one memory segment can be dumped at each time Should generate a Memory dump report , service 6,6		

	MARS EXPRESS OMEGA EXPERIMENT FLIGHT USER MANUAL	Reference : OME-DU-0023-118-IAS Author : M. Berthé Edition : 3 Revision : 0 Rev. date : 15 May 2003 Page : 100
---	---	---

9.4.4) TC service 9, Accept time update

Packet in Hex:

Header: 1D 1C Cx xx 00 0B

Datafield hd: 10 09 01 00

Source data: tt tt tt tt tt tt

CRC: ZZ ZZ

With

x xx: 12 bit counter of TC packet number

tt tt tt tt tt: SCET time valid at next TSY pulse.

ZZ ZZ: CRC field

Telecommand Packet Information			
Packet Name	OME_TIME_UPDATE	Instrument: OMEGA	
Packet Function	distribute time update to OMEGA		
Generation Rules			
Header Information			
Process ID	81d = 51h	Packet Category	12
Service Type	9	Service Subtype	1
Structure ID		Packet Length in Bytes	Datafield = 4 + 6 + 2 = 12 Packet = 12 + 6 = 18
Data Field Information			
Data Field	<i>Field Structure</i>	<i>Remark</i>	
Data field Header	Uint32	as per MEX SGIDB value in hex: 10 09 01 00	
CUC time seconds	Uint32	SCET in CUC format (seconds)	
CUC time sub seconds	Uint16	SCET in CUC format (sub seconds)	
Packet Error Control	Uint16	CRC16 of the TC	

	<p style="text-align: center;">MARS EXPRESS OMEGA EXPERIMENT FLIGHT USER MANUAL</p>	Reference : OME-DU-0023-118-IAS
		Author : M. Berthé
		Edition : 3
		Revision : 0
		Rev. date : 15 May 2003
		Page : 101

9.4.5) TC service 17, Request connect test response

Packet in Hex:

Header: 1D 1C Cx xx 00 05

Datafield hd: 10 11 01 00

CRC: ZZ ZZ

With

x xx: 12 bit counter of TC packet number

ZZ ZZ: CRC field

Telecommand Packet Information			
Packet Name	OME_TEST_REQUEST	Instrument: OMEGA	
Packet Function	request test response from OMEGA		
Generation Rules			
Header Information			
Process ID	81d = 51h	Packet Category	12
Service Type	17	Service Subtype	1
Structure ID		Packet Length in Bytes	Datafield = 4 + 0 + 2 = 6 Packet = 6 + 6 = 12
Data Field Information			
Data Field	<i>Field Structure</i>	<i>Remark</i>	
Data field Header	Uint32	as per MEX SGIDB value in hex: 10 11 01 00	
Packet Error Control	Uint16	CRC16 of the TC	
Note: Should generate a TM packet 9,2			

	MARS EXPRESS OMEGA EXPERIMENT FLIGHT USER MANUAL	Reference : OME-DU-0023-118-IAS Author : M. Berthé Edition : 3 Revision : 0 Rev. date : 15 May 2003 Page : 102
---	---	---

9.4.6) TC service 20, Enable / Disable Science reporting

9.4.6.1) Enable Science reporting via RTU channel

Packet in Hex:

Header: 1D 1C Cx xx 00 07
Datafield hd: 11 14 01 00
Source data: 00 51
CRC: ZZ ZZ

With

x xx: 12 bit counter of TC packet number

ZZ ZZ: CRC field

Telecommand Packet Information			
Packet Name	OME_ENABLE_SC_RTU	Instrument: OMEGA	
Packet Function	enable SC reporting via RTU link from OMEGA		
Generation Rules			
Header Information			
Process ID	81d = 51h	Packet Category	12
Service Type	20	Service Subtype	1
Structure ID		Packet Length in Bytes	Datafield = 4 + 2 + 2 = 8 Packet = 8 + 6 = 14
Data Field Information			
Data Field	<i>Field Structure</i>	<i>Remark</i>	
Data field Header	UInt32	as per MEX SGIDB value in hex: 11 14 01 00	
PID	UInt16	process ID of Science PID (in last 7 bits); 51 hex for Omega hex value: 00 51	
Packet Error Control	UInt16	CRC16 of the TC	

	MARS EXPRESS OMEGA EXPERIMENT FLIGHT USER MANUAL	Reference : OME-DU-0023-118-IAS Author : M. Berthé Edition : 3 Revision : 0 Rev. date : 15 May 2003 Page : 103
---	---	---

9.4.6.2) Disable Science reporting via RTU channel

Packet in Hex:

Header: 1D 1C Cx xx 00 07
Datafield hd: 11 14 02 00
Source data : 00 51
CRC: ZZ ZZ

With

x xx: 12 bit counter of TC packet number
ZZ ZZ: CRC field

Telecommand Packet Information			
Packet Name	OME_DISABLE_SC_RTU	Instrument: OMEGA	
Packet Function	disable SC reporting via RTU link from OMEGA		
Generation Rules			
Header Information			
Process ID	81d = 51h	Packet Category	12
Service Type	20	Service Subtype	2
Structure ID		Packet Length in Bytes	Datafield = 4 + 2 + 2 = 8 Packet = 8 + 6 = 14
Data Field Information			
Data Field	<i>Field Structure</i>	<i>Remark</i>	
Data field Header	Uint32	as per MEX SGIDB value in hex: 11 14 02 00	
PID	Uint16	process ID of Science PID (in last 7 bits); 51 hex for Omega hex value: 00 51	
Packet Error Control	Uint16	CRC16 of the TC	

	MARS EXPRESS OMEGA EXPERIMENT FLIGHT USER MANUAL	Reference : OME-DU-0023-118-IAS Author : M. Berthé Edition : 3 Revision : 0 Rev. date : 15 May 2003 Page : 104
---	---	---

9.4.6.3) Enable Science reporting via HS channel

Packet in Hex:

Header: 1D 1C Cx xx 00 07

Datafield hd: 11 14 0A 00

Source data: 00 51

CRC: ZZ ZZ

With

x xx: 12 bit counter of TC packet number

ZZ ZZ: CRC field

Telecommand Packet Information			
Packet Name	OME_ENABLE_SC_HS	Instrument: OMEGA	
Packet Function	enable SC reporting via High Speed link from OMEGA		
Generation Rules			
Header Information			
Process ID	81d = 51h	Packet Category	12
Service Type	20	Service Subtype	10
Structure ID		Packet Length in Bytes	Datafield = 4 + 2 + 2 = 8 Packet = 8 + 6 = 14
Data Field Information			
Data Field	<i>Field Structure</i>	<i>Remark</i>	
Data field Header	Uint32	as per MEX SGIDB value in hex: 11 14 0A 00	
PID	Uint16	process ID of Science PID (in last 7 bits); 51 hex for Omega hex value: 00 51	
Packet Error Control	Uint16	CRC16 of the TC	

	MARS EXPRESS OMEGA EXPERIMENT FLIGHT USER MANUAL	Reference : OME-DU-0023-118-IAS Author : M. Berthé Edition : 3 Revision : 0 Rev. date : 15 May 2003 Page : 105
---	---	---

9.4.6.4) Disable Science reporting via HS channel

Packet in Hex:

Header: 1D 1C Cx xx 00 07
Datafield hd: 11 14 0B 00
Source data : 00 51
CRC: ZZ ZZ

With

x xx: 12 bit counter of TC packet number
ZZ ZZ: CRC field

Telecommand Packet Information			
Packet Name	OME_DISABLE_SC_HS	Instrument: OMEGA	
Packet Function	disable SC reporting via High Speed link from OMEGA		
Generation Rules			
Header Information			
Process ID	81d = 51h	Packet Category	12
Service Type	20	Service Subtype	11
Structure ID		Packet Length in Bytes	Datafield = 4 + 2 + 2 = 8 Packet = 8 + 6 = 14
Data Field Information			
Data Field	<i>Field Structure</i>	<i>Remark</i>	
Data field Header	Uint32	as per MEX SGIDB value in hex: 11 14 0B 00	
PID	Uint16	process ID of Science PID (in last 7 bits); 51 hex for Omega hex value: 00 51	
Packet Error Control	Uint16	CRC16 of the TC	

	MARS EXPRESS OMEGA EXPERIMENT FLIGHT USER MANUAL	Reference : OME-DU-0023-118-IAS Author : M. Berthé Edition : 3 Revision : 0 Rev. date : 15 May 2003 Page : 106
---	---	---

9.4.7) TC service v255, Common payload services

9.4.7.1) Reset TM output buffer

Packet in Hex:

Header: 1D 1C Cx xx 00 05

Datafield hd: 10 FF 01 00

CRC: ZZ ZZ

With

x xx: 12 bit counter of TC packet number

ZZ ZZ: CRC field

Telecommand Packet Information			
Packet Name	OME_RESET_TM_BUFFER	Instrument: OMEGA	
Packet Function	request for OMEGA to reset its output buffer		
Generation Rules			
Header Information			
Process ID	81d = 51h	Packet Category	12
Service Type	255	Service Subtype	1
Structure ID		Packet Length in Bytes	Datafield = 4 + 0 + 2 = 6 Packet = 6 + 6 = 12
Data Field Information			
Data Field	<i>Field Structure</i>	<i>Remark</i>	
Data field Header	UInt32	as per MEX SGIDB value in hex: 10 FF 01 00	
Packet Error Control	UInt16	CRC16 of the TC	
Note: should reset TM output buffer (RTU link) and stop TM delivery for 8 seconds			

	MARS EXPRESS OMEGA EXPERIMENT FLIGHT USER MANUAL	Reference : OME-DU-0023-118-IAS Author : M. Berthé Edition : 3 Revision : 0 Rev. date : 15 May 2003 Page : 107
---	---	---

9.4.7.2) Reset SMCS Chip

Packet in Hex:

Header: 1D 1C Cx xx 00 05

Datafield hd: 10 FF 02 00

CRC: ZZ ZZ

With

x xx: 12 bit counter of TC packet number

ZZ ZZ: CRC field

Telecommand Packet Information			
Packet Name	OME_RESET_SMCS	Instrument: OMEGA	
Packet Function	request for OMEGA to reset its SMCS		
Generation Rules			
Header Information			
Process ID	81d = 51h	Packet Category	12
Service Type	255	Service Subtype	2
Structure ID		Packet Length in Bytes	Datafield = 4 + 0 + 2 = 6 Packet = 6 + 6 = 12
Data Field Information			
Data Field	<i>Field Structure</i>	<i>Remark</i>	
Data field Header	UInt32	as per MEX SGIDB value in hex: 10 FF 02 00	
Packet Error Control	UInt16	CRC16 of the TC	
Note: should reset HS link handling logic			

	<p style="text-align: center;">MARS EXPRESS OMEGA EXPERIMENT FLIGHT USER MANUAL</p>	Reference : OME-DU-0023-118-IAS
		Author : M. Berthé Edition : 3 Revision : 0 Rev. date : 15 May 2003 Page : 108

9.4.7.3) Start HS Link

Packet in Hex:

Header: 1D 1C Cx xx 00 05

Datafield hd: 10 FF 03 00

CRC: ZZ ZZ

With

x xx: 12 bit counter of TC packet number

ZZ ZZ: CRC field

Telecommand Packet Information			
Packet Name	OME_START_HS	Instrument: OMEGA	
Packet Function	request for OMEGA to start the HS link		
Generation Rules			
Header Information			
Process ID	81d = 51h	Packet Category	12
Service Type	255	Service Subtype	3
Structure ID		Packet Length in Bytes	Datafield = 4 + 0 + 2 = 6 Packet = 6 + 6 = 12
Data Field Information			
Data Field	<i>Field Structure</i>	<i>Remark</i>	
Data field Header	Uint32	as per MEX SGIDB value in hex: 10 FF 03 00	
Packet Error Control	Uint16	CRC16 of the TC	
Note: should start the HS link handling procedure			

	MARS EXPRESS OMEGA EXPERIMENT FLIGHT USER MANUAL	Reference : OME-DU-0023-118-IAS Author : M. Berthé Edition : 3 Revision : 0 Rev. date : 15 May 2003 Page : 109
---	---	---

9.4.7.4) Reset SMCS and Start HS Link

Packet in Hex:

Header: 1D 1C Cx xx 00 05

Datafield hd: 10 FF 04 00

CRC: ZZ ZZ

With

x xx: 12 bit counter of TC packet number

ZZ ZZ: CRC field

Telecommand Packet Information			
Packet Name	OME_RESET_AND_START_HS	Instrument: OMEGA	
Packet Function	request for OMEGA to Reset SMCS and Start HS Link		
Generation Rules			
Header Information			
Process ID	81d = 51h	Packet Category	12
Service Type	255	Service Subtype	4
Structure ID		Packet Length in Bytes	Datafield = 4 + 0 + 2 = 6 Packet = 6 + 6 = 12
Data Field Information			
Data Field	<i>Field Structure</i>	<i>Remark</i>	
Data field Header	UInt32	as per MEX SGIDB value in hex: 10 FF 04 00	
Packet Error Control	UInt16	CRC16 of the TC	
Note: should Reset SMCS and Start HS Link			