

# *Rosetta-Alice*

## **EXPERIMENT USER MANUAL** (Version 2, Protoflight Model)

February 2018

SwRI Project No. 15-8225

Document No. 8225-EUM-01

Rev. 2

DRD 65.3

JPL Contract 1200328

Prepared by

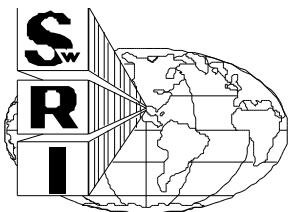

**SOUTHWEST RESEARCH INSTITUTE**

Space Science and Engineering Division  
6220 Culebra Road, San Antonio, Texas 78228-0510  
(210) 684-5111 • FAX (210) 543-0052

# *Rosetta-Alice*

## **EXPERIMENT USER MANUAL** (Version 2, Protoflight Model)

SwRI Project 15-8225

Document No. 8225-EUM-01  
Rev. 2

DRD 65.3

Contract JPL-1200328

Prepared by:	D. C. Slater, Project Scientist	Date	December 2006
Reviewed by:	_____	Date	_____
	S. A. Stern, Principal Investigator		
Reviewed by:	_____	Date	_____
	J. Wm. Parker, Project Manager		
Reviewed by:	_____	Date	_____
	M. Versteeg, Lead Software Engineer		
Reviewed by:	_____	Date	_____
	P. B. Gupta, P. A. Engineer		
Reviewed by:	_____	Date	_____
	ESA Representative		

Instrumentation and Space Research Division  
Southwest Research Institute  
P. O. Drawer 28510  
6220 Culebra Road  
San Antonio, Texas 78228-0510  
(210) 684-5111

# TABLE OF CONTENTS

<b>DOCUMENTATION CHANGE RECORD.....</b>	<b>v</b>
<b>LIST OF ACRONYMS AND ABBREVIATIONS .....</b>	<b>vii</b>
<b>1 GENERAL DESCRIPTION.....</b>	<b>9</b>
1.1 ALICE TEAM .....	9
1.2 SCIENTIFIC OBJECTIVES (ALICE EID-B, § 1.1.1) .....	9
1.3 EXPERIMENT OVERVIEW .....	11
<b>2 EXPERIMENT CONFIGURATION.....</b>	<b>13</b>
2.1 ELECTRICAL .....	13
2.1.1 Power Interface Circuits (Alice EID-B, § 2.4).....	13
2.1.2 Pyrotechnic Interface Circuits (Alice EID-B, § 2.5).....	16
2.1.3 OBDH Interface Circuits (Alice EID-B, § 2.7).....	17
2.1.4 Instrument Heaters.....	19
2.1.5 Instrument Thermistors/Housekeeping Sensors .....	19
2.2 SOFTWARE (DRD 28.1) .....	19
2.2.1 Software Overview.....	19
2.2.2 Autonomy Concept.....	20
2.2.3 Software Maintenance Approach.....	21
2.2.4 Data Delivery Concept: Application Process IDs (APIDs).....	23
2.2.5 Timing Requirements .....	24
2.2.6 Boot Sequence.....	26
2.2.7 Instrument Operating Modes .....	26
2.3 BUDGETS (DRD 12.2).....	29
2.3.1 Mass .....	29
2.3.2 Operating Power (Alice EID-B, § 2.4.3).....	30
2.3.3 Data Rates (Housekeeping and Science) .....	30
2.3.4 Non Operating Heaters (Alice EID-B, § 2.3.3.2).....	35
2.3.5 S/C Powered Thermistors (Alice EID-B, § 2.3.3.4) .....	35
2.3.6 Pyro Lines (Alice EID-B, § 2.5).....	35
2.3.7 OBDH Channels (Alice EID-B, § 2.7.5) .....	35
2.4 FLIGHT DATA ARCHIVE PLAN/DISTRIBUTION PLAN.....	35
<b>3 EXPERIMENT OPERATIONS.....</b>	<b>36</b>
3.1 OPERATING PRINCIPLES.....	36
3.1.1 Instrument Overview.....	36
3.1.2 Optical Design .....	36
3.1.3 Entrance Slit Design .....	37
3.1.4 Detector and Detector Electronics.....	38
3.1.5 Electrical Design .....	39
3.1.6 Data Collection Modes .....	41
3.1.7 Detector Acquisition Durations .....	42
3.1.8 Analog versus Digital Detector Count Rates and Rate Doubling.....	43
3.1.9 Code Memory Management.....	44
3.1.10 Software Code Patch Operation .....	44
3.1.11 In-Flight Aperture Door Performance Tests.....	45
3.1.12 Fail-Safe Door Activation.....	45
3.2 OPERATING MODES.....	46
3.2.1 Ground Test Plan (from Alice EID-B, § 5) .....	46
3.2.2 In-orbit Commissioning Plan.....	47
3.2.3 Instrument Checkout and In-Flight Calibration .....	50
3.2.4 Flight Operations Plans per Mission Phase.....	51
3.2.5 Interferences .....	53

3.2.6	Operational Constraints (Flight Rules)	53
3.3	FAILURE DETECTION AND RECOVERY STRATEGY	56
<b>4</b>	<b>MODE DESCRIPTIONS</b>	<b>60</b>
4.1	MODE TRANSITION TABLE	60
4.2	DETAILED MODE DESCRIPTIONS	61
<b>5</b>	<b>OPERATIONAL PROCEDURES (DRD 51.2)</b>	<b>61</b>
5.1	GROUND TEST SEQUENCES	61
5.2	ON-BOARD CONTROL PROCEDURES	63
5.3	FLIGHT CONTROL PROCEDURES	63
5.4	CONTINGENCY RECOVERY PROCEDURES (EID-B, §6.5.4)	63
<b>6</b>	<b>DATA OPERATIONS HANDBOOK (DRD 65.2)</b>	<b>67</b>
6.1	TELECOMMAND PACKET AND PARAMETER DEFINITIONS	68
6.2	TELEMETRY PACKET AND PARAMETER DEFINITIONS	80
6.3	EVENT PACKET DEFINITIONS	92
6.4	ANOMALY REPORT DEFINITIONS	92
6.5	CONTEXT FILE DEFINITION	93
6.6	DATA AND DUMP FILE DEFINITIONS	94
6.7	SSMM UTILIZATION	95
6.8	INFORMATION DISTRIBUTION REQUIREMENTS	95
6.9	ON-BOARD CONTROL PROCEDURES	96
6.10	ALICE PAD FIELD HANDLING	96
<b>7</b>	<b>ROSETTA–ALICE EQM AND STB CONFIGURATION AND USE</b>	<b>98</b>
<b>8</b>	<b>ATTACHMENTS</b>	<b>99</b>
8.1	ATTACHMENT 1: ALICE HOT UV STAR LIST	99
8.2	ATTACHMENT 2: ALICE IN-FLIGHT APERTURE DOOR PERFORMANCE TEST	99

### LIST OF FIGURES

Figure 1.3-1.	The opto-mechanical layout of Alice	12
Figure 1.3-2.	External view of Alice	12
Figure 1.3-3.	Photograph of the Alice protoflight model with the top cover removed	13
Figure 1.3-4.	Block diagram of Alice	13
Figure 2.2-1.	The Alice power system	14
Figure 2.2-2.	Alice telecommand interface circuit	18
Figure 2.2-3.	Alice telemetry interface circuit	18
Figure 2.3-1.	Alice memory map	23
Figure 2.3-2.	The Alice software operating state diagram	29
Figure 3.1-1.	The Alice entrance slit design. (a) The physical dimensions of the slit. (b) The slit orientation with respect to the DDL detector image spatial axis, and the spacecraft axes	36
Figure 3.1-2.	(Left) Schematic of the Alice DDL detector vacuum housing; (Right) Photograph of the PFM DDL detector vacuum housing	38
Figure 3.1-3.	The Alice electrical block diagram	40

Figure 4.1-1. The Alice top-level mode transitions. ....	60
Figure 6.10-1 - Alice EQM.....	98
Figure 6.10-2 - Alice STB .....	98

**LIST OF TABLES**

Figure 1.3-1. The opto-mechanical layout of Alice. ....	12
Figure 1.3-2. External view of Alice.....	12
Figure 1.3-3. Photograph of the Alice protoflight model with the top cover removed.....	13
Figure 1.3-4. Block diagram of Alice. ....	13
Figure 2.2-1. The Alice power system.....	14
Figure 2.2-2. Alice telecommand interface circuit.....	18
Figure 2.2-3. Alice telemetry interface circuit.....	18
Figure 2.3-1. Alice memory map.....	23
Figure 2.3-2. The Alice software operating state diagram.....	29
Figure 3.1-1. The Alice entrance slit design. (a) The physical dimensions of the slit. (b) The slit orientation with respect to the DDL detector image spatial axis, and the spacecraft axes. ....	36
Figure 3.1-2. (Left) Schematic of the Alice DDL detector vacuum housing; (Right) Photograph of the PFM DDL detector vacuum housing. ....	38
Figure 3.1-3. The Alice electrical block diagram. ....	40
Figure 4.1-1. The Alice top-level mode transitions. ....	60
Figure 6.10-1 - Alice EQM.....	98
Figure 6.10-2 - Alice STB .....	98

**DOCUMENTATION CHANGE RECORD**

Ver/Rev	Section	Date	Changes
1/0		2/23/00	First Draft Issue
1/1	--	10/16/00	Rev. 1 Issue
1/2		05/10/01	Rev. 2 Draft Issue
1/2	All	5/16/01	Rev. 2 Issue
1/3	3.2.1 3.2.2 6.7	7/5/02	Rev. 3 Issue Minor wording changes in description of detector tests Referenced new Commissioning Plan document Added attachment 7: Commissioning Sequences
1/3	2.2 3.1 3.2.2 3.2.3 3.4 4.1 5.1 5.3 5.4 6.9 7.2 7.7 7.8 7.9 7.10	7/20/02 7/26/02	Filled in TBDs in Table 2.2-2 (EMI Characteristics) Rev. 3 Modifications (post EFOR meeting). Minor changes to Section 3.1. Reference to Commissioning Plan in Section 3.2.2. Reference to Commissioning Plan in Section 3.2.3. Added new Section 3.4 “Operational Constraints”. Added descriptive text to Section 4.1. Added description of MST (Section 5.1). Reference to Commissioning Plan in Section 5.3. Additional details added to Section 5.4 (including subsection on S/C detected out-of-limits. Added new Section 6.9 “ <i>Alice</i> PAD Field Handling Added new/updated documents to Attachments 2 (On-Board Software & Autonomous Functions); 7 (Commissioning Sequences for <i>Alice</i> ); 8 (Test Sequence Definitions for <i>Alice</i> System Validation Test); 9 ( <i>Alice</i> RSDB Summary); and 10 (Copy of EMI Waiver RO-ALI-RW-009)
1/4	1.1 2.2.1 2.3 2.4 2.5.2 3.1.3 3.1.4 3.1.5 3.1.6 3.1.11 5.4 5.4 7.11	11/2003	Updated with new target comet 67P/CG Removed TBRs in Figure 2.2-2 Added reference to the <i>Alice</i> Ground Software Added section describing the flight data archive plan Updated the <i>Alice</i> Power Consumption table 2.5-1 Updated “Aliveness/Functional Tests” text Added section “Code Memory Management” Added section “Software Code Patch Operation” Updated “Optical Alignment Check” text Added section “Fail-Safe Activation” Removed TBD of heater temperature sensor disagreement Removed TBD in “S/C Detected Out-of-Limits”; added Table 5.4-1: S/C monitored <i>Alice</i> parameters; added further description of <i>Alice</i> “return to safe state” during MAD acquisition sequences Added the <i>Alice</i> Hot UV Star List—Attachment 11
1/5	3.4 2.5.3 3.1.3 3.1.12	10/2004 01/2005 01/2005 01/2005	Added new flight rule—the detector HVPS shall not be on during any spacecraft thruster firings. Added diagnostic data description. Added descriptions of “active” and “passive” checkouts. Added section “In-Flight Aperture Door Performance Tests”

Ver/Rev	Section	Date	Changes
	7.11	01/2005	Updated the UV Hot Start List based on latest in-flight calibration results.
	7.12	01/2005	Added Attachment 12: In-Flight Aperture Door Performance Tests to describe results of tests to date.
	3.4	02/2005	Replaced “Operational Constraints” section with a reference to the formal <i>Alice</i> Flight Rules document (placed as an Attachment 13 to the User Manual).
1/6	3.13 Att. 13	04/2005 04/2005	Updated plan for passive and active checkouts. Flight rules now permanent attachment to this document, and no longer maintained as a separate document. General reformatting. Change Flight Rule BRT.2 clarifying that solar elongation limits are applicable whenever <i>Alice</i> is ON, not just at a particular voltage). Change Flight Rule BRT.3 to read “HV>2500” rather than “HV>250”. Changed HV.4 to allow for turning down HV to 2500 V.
2/0	1.3 2.3 6 Att. 2 2.2.4 2.2.5 2.5.2 3.1 3.2 7 3.4 1.1	08/2006	Updated Section 1.3; replaced Fig. 1.3.3 with simpler instrument block diagram; inserted a photograph of the <i>Alice</i> PFM. Moved attachment 2 (On-board Software and Autonomous Functions) into the main document in Sections 2.3 and 6. Added Standard Sequences document in Attachment 2 Added descriptions Section 2.2.4 Instrument Heaters, and Section 2.2.5 Instrument Thermistors/Housekeeping Sensors Added power table per operational mode (Table 2-12) Replaced Operating Principles Section 3.1 with updated comprehensive instrument description and function description Updated Nominal Operational Plans (Section 3.2) and Mode Descriptions (Section 4) Added Section 7 describing EQM and STB Moved Attachment 13 ( <i>Alice</i> Flight Rules) and to Section 3.4 of main document Added team list
2/0	2.3.5 2.4.3 3.1.3 3.1.4 3.1.6 3.1.7 3.1.8 6 6.10 7	11/2006	Updated List of Acronyms and Abbreviations Added Version 2.05 flight software description Updated Table “Acquisition data volume modifiers” Updated and added new slit design figure Updated and added figure of DDL detector Minor updates Minor updates Minor updates Added introductory paragraph description Added new Version 2.05 FSW PAD field handling functionality Added new section describing the Alice EQM and STB
2/1	2.5	03/2010	Updated Flight Data Archive plan section
2/2	8	02/2018	Removed blank attachments 1-10 from Section 8, and all references to them in the text; renumbered Attachments 11 and 12 to 1 and 2, respectively.

## LIST OF ACRONYMS AND ABBREVIATIONS

A/D	Aperture Door
AFT	Abbreviated Functional Test
APID	Application Process Identification
BOL	Beginning-of-Life
BT	Bench Test
C&DH	Command-and-Data-Handling Electronics
CCP	Contamination Control Plan
CCSDS	Consultative Committee for Space Data Systems
D/D	Detector Door
DDL	Double-Delay Line
DDS	Data Disposition System
EEPROM	Electrically Erasable Programmable Read Only Memory
EGSE	Electrical Ground Support Equipment
EID	Experiment Interface Document
EMC	Electromagnetic Compatibility
EMI	Electromagnetic Interference
EOL	End-of-Life
ESA	European Space Agency
ESD	Electrostatic Discharge
ESD	Electrostatic Discharge
EUV	Extreme Ultraviolet
FFT	Full Functional Test
FOV	Field-of-View
FUV	Far Ultraviolet
GN <sub>2</sub>	Gaseous Nitrogen
GSE	Ground Support Equipment
HK	Housekeeping
HTR	Heater
HV	High Voltage
HVPS	High Voltage Power Supply
ICD	Interface Control Document
IFOV	Instantaneous Field-of-View
IST	Integrated System Test
LCL	Latching Current Limiter
MAD	Multiple Acquire Dump
MCP	Microchannel Plate
MICD	Mechanical Interface Control Document
MST	Mission Simulation Test
NVR	Non-Volatile Residue
OAP	Off-Axis Paraboloid
OBDH	On-Board Data Handling
OSIRIS	Optical, Spectroscopic, and Infrared Remote Imaging System
PAD	Filler field in CCSDS packets used to return TC token into TM packet
PAIP	Product Assurance Implementation Plan
PFM	Protoflight Model



PHD	Pulse-Height Distribution
POT	Pump Out Tube
PROM	Programmable Read Only Memory
PS	Power Supply
RTN	Return
S/C	Spacecraft
SFT	System Functional Test
SIS	Spacecraft Interface Simulator
SPT	Specific Performance Test
SVT	System Validation Test
SwRI	Southwest Research Institute
TB	Thermal Balance
TBC	To Be Confirmed
TBD	To Be Determined
TBR	To Be Resolved
TC	Thermocouple
TM	Telemetry
TRP	Temperature Reference Point
TV	Thermal Vacuum
URF	Unit Reference Axes
UV	Ultraviolet
VIRTIS	Visible and Infrared Thermal Imaging Spectrometer
WAC	Wide Angle Camera (OSIRIS)

## 1 General Description

### 1.1 Alice Team

Alan Stern (PI), SwRI, [astern@boulder.swri.edu](mailto:astern@boulder.swri.edu), +1 303-546-9670

John Scherrer (Pre-launch Project Manager), SwRI, [jscherrer@swri.org](mailto:jscherrer@swri.org), +1 210-522-3363

Joel Parker (Post-launch Project Manager; Post-encounter PI; ops; data processing; archiving), SwRI, [joel@boulder.swri.edu](mailto:joel@boulder.swri.edu), +1 303-546-9670

Dave Slater (Project Scientist), SwRI, [dslater@swri.org](mailto:dslater@swri.org), +1 210-522-2205

Andrew Steffl (Project Scientist; Co-Investigator; ops; data processing, calibrations, archiving), SwRI, [steffl@boulder.swri.edu](mailto:steffl@boulder.swri.edu), +1 720-240-0161

Paul Feldman (Science Team Co-Investigator), APL/JHU, [pdf@pha.jhu.edu](mailto:pdf@pha.jhu.edu), +1 410-516-7339

Mike A'Hearn (Science Team Co-Investigator), U. Maryland, [ma@astro.umd.edu](mailto:ma@astro.umd.edu), +1 301-405-6076

Jean-Loup Bertaux (Science Team Co-Investigator), [Jean-Loup.Bertaux@aerov.jussieu.fr](mailto:Jean-Loup.Bertaux@aerov.jussieu.fr), (33) 1 6920-3116

Harold Weaver (Science Team Co-Investigator), APL/JHU, [Hal.Weaver@jhuapl.edu](mailto:Hal.Weaver@jhuapl.edu), +1 443-778-5000

Lori Feaga (Science Team Co-Investigator), U. Maryland, [feaga@astro.umd.edu](mailto:feaga@astro.umd.edu), +1 443-778-5000

Eric Schindhelm (Deputy Project Scientist; ops; data processing; science tools), SwRI, [eric@boulder.swri.edu](mailto:eric@boulder.swri.edu),

Maarten Versteeg (Lead Software Engineer; ops), SwRI, [mversteeg@swri.org](mailto:mversteeg@swri.org), +1 210-522-5029

Emma Birath (ops support), SwRI, [emma@boulder.swri.edu](mailto:emma@boulder.swri.edu), +1 720-240-0144

Jon Pineau (ops support), Stellar Solutions, [jpineau@stellarsolutions.com](mailto:jpineau@stellarsolutions.com),

Richard Medina (ops support), SwRI, [richard.medina@boulder.swri.edu](mailto:richard.medina@boulder.swri.edu), +1 303-226-5909

David Kaufmann (downlink processing, archiving), SwRI, [kaufmann@boulder.swri.edu](mailto:kaufmann@boulder.swri.edu), 720-240-0119

### 1.2 Scientific Objectives (Alice EID-B, § 1.1.1)

The scientific objectives of the *Alice* investigation are to characterize the composition of the nucleus and coma, and the coma/nucleus of comet 67P/Churyumov-Gerasimenko. This will be accomplished through the observation of spectral features in the 700-2050 Å EUV/FUV region. *Alice* will provide measurements of noble gas abundances in the coma, the atomic budget in the coma, major ion abundances in the tail and in the region where solar wind particles interact with the ionosphere of the comet, determine the production rates, variability, the structure of H<sub>2</sub>O, CO and CO<sub>2</sub> gas surrounding the nucleus, and the far-UV properties of solid grains in the coma. *Alice* will also map the cometary nucleus in the FUV, and study Mars, the *Rosetta* asteroid flyby targets Steins and Lutetia, and targets of opportunity while en route to Churyumov-Gerasimenko.

Ultraviolet spectroscopy is a powerful tool for studying astrophysical objects, and has been applied with dramatic success to the study of comets. *Alice* will provide unprecedented improvements in sensitivity and spatial resolution over previous cometary UV observations. For example, *Alice* will move the sensitivity threshold from the ~1 Rayleigh level achievable with the Hubble Space Telescope to the milliRayleigh level in deep integrations. In addition, *Alice* will (by virtue of its location at the comet) move the spatial exploration of nucleus UV surface properties from the present-day state-of-the-art (i.e., no data available on any comet) to complete nuclear maps at Nyquist-sampled resolutions of a few hundred meters. Stars occulted by the absorbing coma will also be observed and used to map the water molecule spatial distribution, giving us hints at how the production regions are located on the nuclear surface.

A summary of the *Alice* performance/capabilities is given in Table 1-1.

Through its remote-sensing nature, *Alice* will be able to:

- Obtain compositional and morphological information on the comet prior to the rendezvous, thereby providing planning observations for in situ instruments prior to entering orbit about the comet.
- Map the spatial distribution of key species in the coma, and small coma dust grains, as a function of time as the comet responds to the changing solar radiation field during its approach to the Sun.
- Obtain compositional and production rate measurements of nuclear jets and other inner coma features even when the orbiter is not in the vicinity of these structures.
- Obtain certain ion abundance measurements around perihelion in order to connect nucleus activity to changes in tail morphology and structure, and coupling to the solar wind.

The primary scientific themes of the *Alice* investigation are the following (not prioritized):

- Determine the rare gas content of the nucleus to provide information on the temperature of formation and the thermal history of the comet since its formation. Ar and Ne will be prime targets of the *Alice* investigations.
- Determine the production rates and spatial distributions of the key parent molecule species, H<sub>2</sub>O, CO and CO<sub>2</sub>, thereby allowing the nucleus/coma coupling to be directly observed and measured on many time-scales in order to study the chemical heterogeneity of the nucleus and its coupling to the coma.
- Obtain an unambiguous budget of the cosmogonically most important atoms C, H, O, N, and S through the detection of their emissions far from the nucleus. This is required to understand their production processes and to derive the elemental composition of the volatile fraction of the nucleus. Coupled to the measure of the major molecule abundances of the nucleus, this will give us the total contribution of the secondary parent species to the compositional makeup of the nucleus.
- Study the onset of nuclear activity and nucleus output variations related to changing solar aspect and nuclear rotation with unprecedented sensitivity.

Additional scientific themes *Alice* will address include the following:

- Spectral mapping of the complete nucleus at far-UV wavelengths to characterize the distribution of UV absorbers on the surface, in particular icy patches and organics.
- Photometric properties and ice/rock ratio of small grains in the coma as an aid to understanding the size distribution of cometary grains and how they vary in time. Also, studying the grain coma to establish the relative contributions of the nucleus and coma grains to the observed gases.
- Mapping the time variability of O<sup>+</sup>, N<sup>+</sup>, and possibly S<sup>+</sup> and C<sup>+</sup> emissions in the coma and ion tail in order to connect nuclear activity to changes in tail morphology and structure, and tail interaction/coupling to the solar wind.

*Table 1-1. Approximate Alice Characteristics and Performance Overview*

Passband	700-2050 Å
Spectral Resolution ( $\Delta\lambda$ FWHM)	8-12 Å (extended source) 4-9 Å (point source)
Spatial Resolution	0.05° x 0.6° (Nyquist)
Effective Area	0.02 (1575 Å)-0.05 cm <sup>2</sup> (1125 Å)
Field of View	0.05° x 2.0° + 0.1° x 2.0° + 0.1° x 1.5°
Pointing	Boresight with OSIRIS, VIRTIS
Observation Types	Nucleus Imaging and Spectroscopy; Coma Spectroscopy
	Jet and Grain Spectrophotometry; Stellar Occultations (secondary observations)
Telescope/ Spectrograph	Off-axis telescope, 0.15-m diameter Rowland circle spectrograph
Detector Type	2-D Microchannel Plate with double-delay line anode readout

### 1.3 Experiment Overview

The *Alice* UV spectrometer is a very simple instrument. An opto-mechanical layout of the instrument is shown in Figure 1.3-1. Light enters the telescope section through a 40 x 40 mm<sup>2</sup> entrance aperture and is collected and focused by an *f*/3 off-axis paraboloidal (OAP) primary mirror onto the approximately 0.1° x 6° spectrograph entrance slit (see below for a description of the entrance slit geometry). After passing through entrance slit, the light falls onto a toroidal holographic grating, where it is dispersed onto a microchannel plate (MCP) detector that uses a double-delay line (DDL) readout scheme. The 2-D (1024 x 32)-pixel format, MCP detector uses dual, side-by-side, solar-blind photocathodes of potassium bromide (KBr) and cesium iodide (CsI). The predicted spectral resolving power ( $\lambda/\Delta\lambda$ ) of *Alice* is in the range of 70-170 for an extended source that fills the instantaneous field-of-view (IFOV) defined by the size of the entrance slit. *Alice* is controlled by an SA 3865 microprocessor, and utilizes lightweight, compact, surface mount electronics to support the science detector, as well as the instrument support and interface electronics. Figure 1.3-2 shows a three-dimensional external view of *Alice*; a photograph of the *Alice* protoflight model (PFM) is shown in Figure 1.3-3. The resulting design is highly systems-engineered to minimize mass and complexity, and enjoys strong parts-level heritage from previous UV spectrometers. A simple block diagram of the *Alice* electronics is shown in Figure 1.3-4.

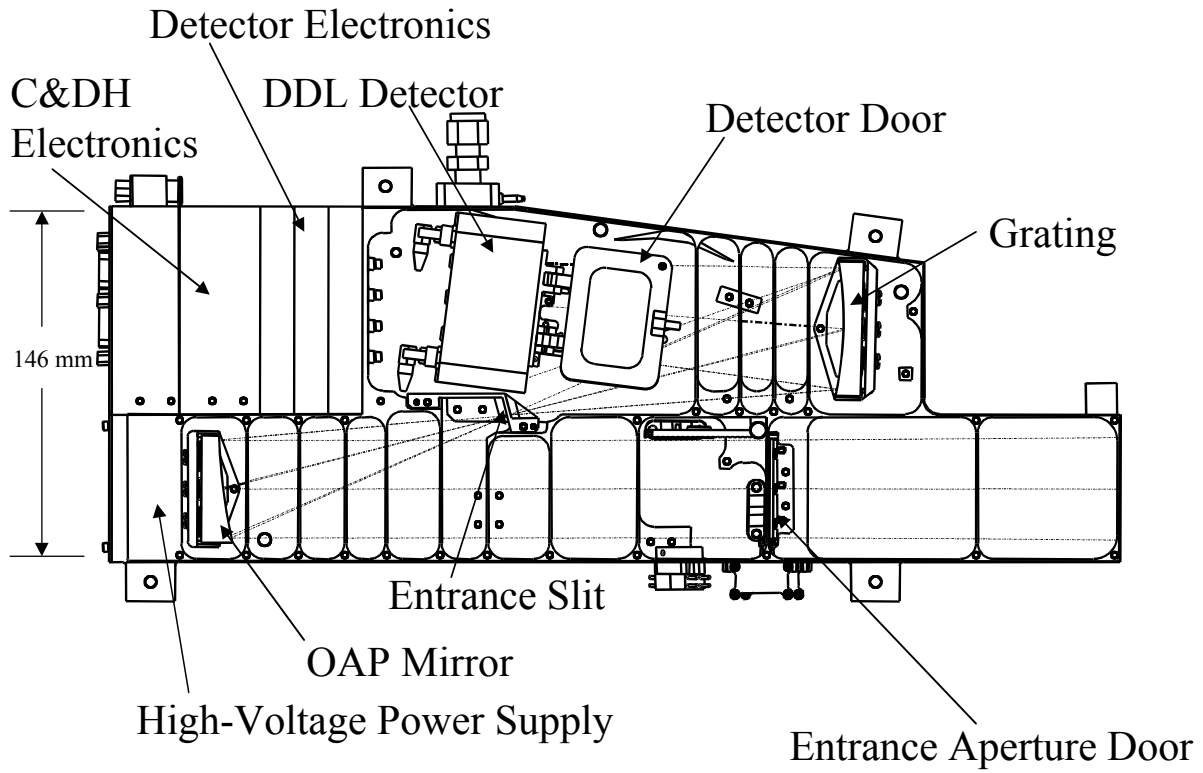

*Figure 1.3-1. The opto-mechanical layout of Alice.*

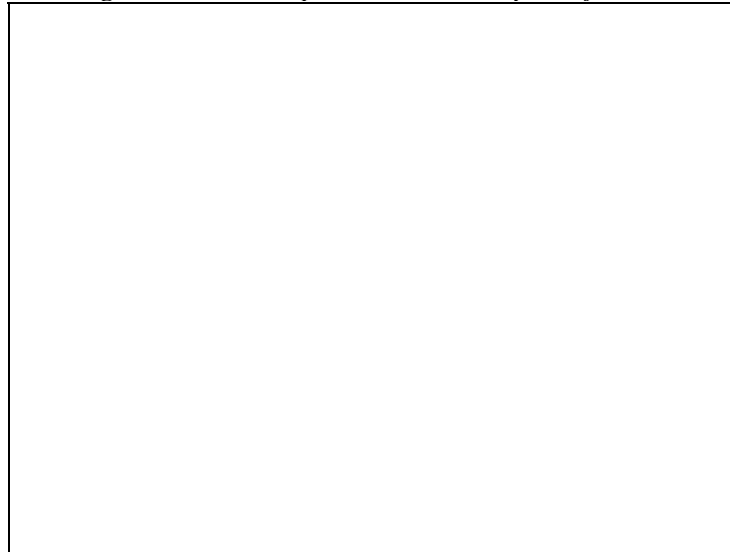

*Figure 1.3-2. External view of Alice.*

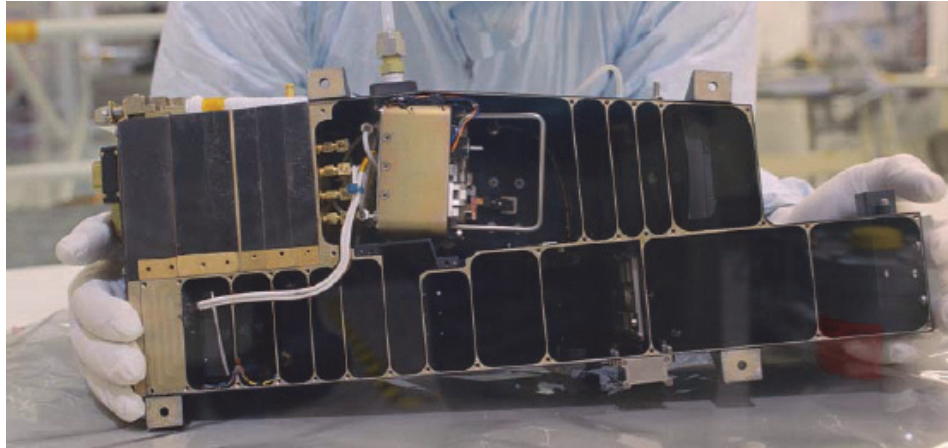

Figure 1.3-3. Photograph of the Alice protoflight model with the top cover removed.

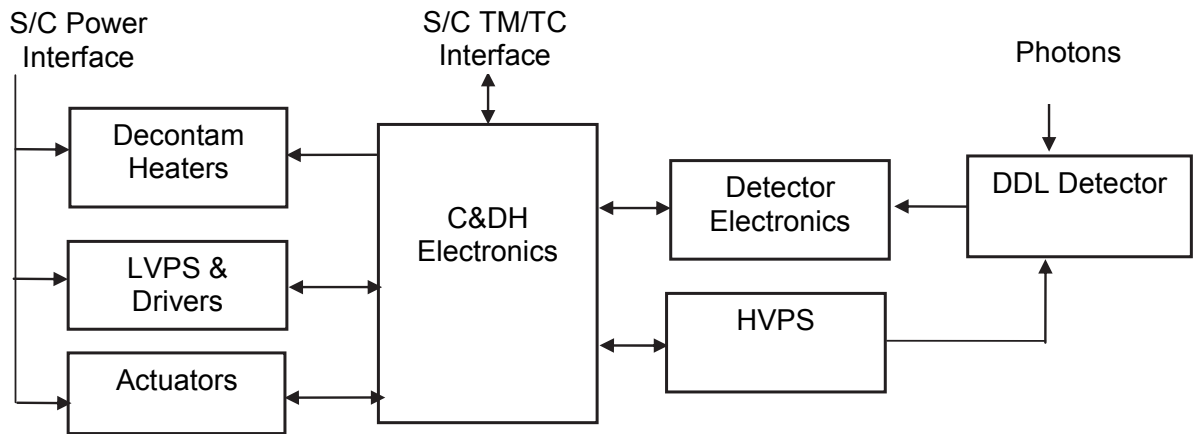

Figure 1.3-4. Block diagram of Alice.

## 2 Experiment Configuration

### 2.1 Electrical

#### 2.1.1 Power Interface Circuits (Alice EID-B, § 2.4)

The *Alice* instrument derives operating power from an isolated dual output DC/DC converter and a single high voltage power supply. A common filter module for incoming spacecraft power is used to both protect the instrument from transients and to filter instrument generated noise from coupling to other spacecraft systems. Figure 2.1-1 illustrates the number and type of power input lines (with returns) used by *Alice*. Table 2-1 lists these lines.

Table 2-1. Power Supply Interface Requirements

			LCL Class
--	--	--	-----------

Function	Number of Main Lines Required	Number of Redundant Lines Required	
+ 28 V MAIN BUS (Switched and Current limited)	1	1	B
Decontamination Nonops Heater	0	0	
Keep-Alive Supply	0	0	

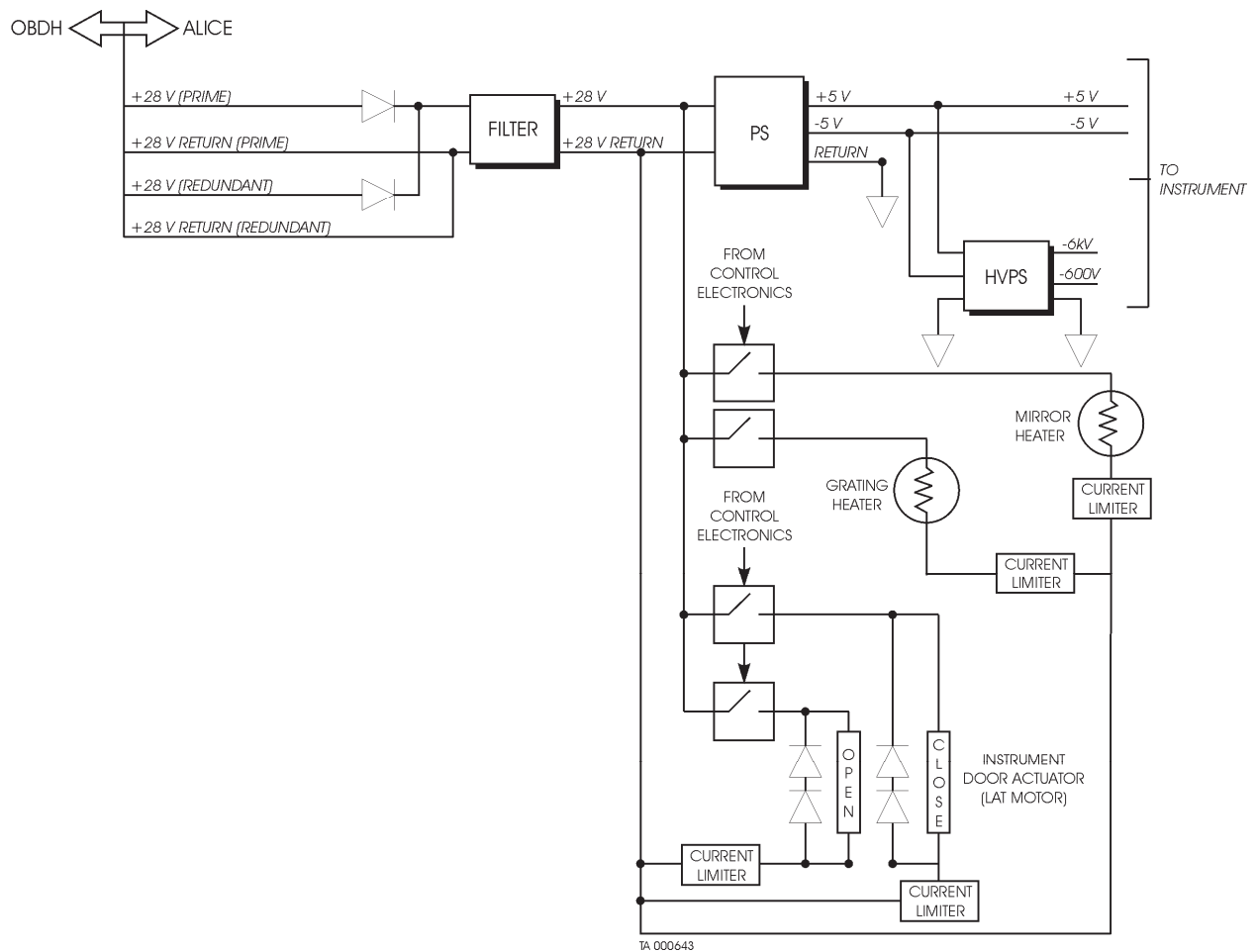

Figure 2.1-1. The Alice power system.

Electrical interface circuits used by the *Alice* instrument consist of the following types of interfaces:

- Operating +28 V power interface (prime and redundant) [Includes the heater power and the door actuation power]
- Operating power return (prime and redundant)

- Chassis ground

The *Alice* instrument provides a diode-or circuit to generate a single operational +28 V supply that is then filtered and distributed to the instrument through an isolated DC/DC converter which generates +5V and - 5V and that runs at a nominal frequency of 550 kHz. A high voltage power supply (HVPS) with outputs from 0 kV to -6.5 kV is supplied from the +5V and -5V supplies. The characteristics of this interface are summarized in Table 2-2.



Table 2-2. Operational Power Interface Characteristics

INTERFACE DESIGNATION	PRIMARY INSTRUMENT POWER
<b>Maximum Average Input Current (@ 28V)</b>	
Normal (Full Instrument Operation)	0.129A - 0.143A
Decontamination Operations (Occasionally throughout mission)	0.143A - 0.214A (nominal < 1 hr., but up to 24 hr during commissioning)
Daily multiples (Instrument Door Actuation)	0.329A - 0.343A (2 second maximum)
<b>Inrush Characteristics</b>	
Peak current @25V (Assuming 35 % overshoot)	0.8 A
Current at t >8 ms	0.129 A
<b>Isolation</b>	
28V input to chassis	>300 Mohm
28V input to secondary return	>300 Mohm
28V return to chassis	>300 Mohm
28V return to secondary return	>300 Mohm
Secondary return to chassis (when single point ground attachment is removed)	0 Mohm
<b>EMI Characteristics</b>	
Requirements per Paragraph 2.4.9 EID-A	Converter switching frequency is 550 kHz
One Waiver for out-of-spec performance in CONSERT notch (see Waiver RO-ALI-RW-009)	10 dB out at 90 MHz

### 2.1.2 Pyrotechnic Interface Circuits (Alice EID-B, § 2.5)

*General Description.* The Alice instrument uses pyrotechnic devices called dimple actuators to initiate several functions. It uses a pair of dimple actuators to release the mechanism that secures the detector vacuum cover, a second pair (primary and redundant) to release the latch that holds the aperture door locked during launch, and a third pair (primary and redundant) to release the fail-safe aperture door if the primary aperture door should be rendered inoperable during the course of the mission. Separate connections between the pyrotechnic connector and each dimple actuator (primary and redundant) are implemented. All six actuators are activated directly by the spacecraft upon ground command. Table 2-3 lists the Alice pyrotechnic devices. The initiator characteristics are given in the Alice EID-B, § 2.5, Table 2.5.1-2.

Table 2-3. Initiator Function and Supply

Function	Initiator Principle	Power supplied by (if applicable)
Detector Door Opening (prime and redundant)	Dimple Actuator	Spacecraft Pyrotechnic Interface Connector
Aperture Door Uncage (prime and redundant)	Dimple Actuator	Spacecraft Pyrotechnic Interface Connector

Function	Initiator Principle	Power supplied by (if applicable)
Aperture failsafe door (prime and redundant)	Dimple Actuator	Spacecraft Pyrotechnic Interface Connector

*Electro-Explosive Devices (Pyrotechnic Initiators).* All pyrotechnic interfaces are implemented using the model 1MT1130 dimple actuator manufactured by Eagle-Picher Technologies. This initiator has the characteristics outlined in Table 2.5.1-2 in the *Alice* EID-B and meets the requirements outlined in EID-A Section 2.5. Redundant connections between the spacecraft pyrotechnic interface connector and each initiator ensure that a single failure will not prevent the initiators from activating.

*Safety.* The *Alice* program will provide a plug for insertion into the spacecraft pyrotechnic connector that contains the ESD and dummy load resistors required by EID-A Section 2.5.1.2. This plug will stay attached at all times except when the *Alice* instrument is mated to the spacecraft harness and will prevent accidental actuation of the device.

### 2.1.3 OBDH Interface Circuits (*Alice* EID-B, § 2.7)

The *Alice* instrument interfaces to the spacecraft OBDH as outlined in Table 2-4. The interfaces listed are compliant with EID-A, Section 2.7.

Table 2-4. *Alice* OBDH Interface Channels/Functions

Interface	Signal Type or Function	Main	Redundant
Telecommand Channels	Memory Load Commands 16 bit serial digital	1	1
	High Power ON/OFF Commands	0	0
Telemetry Channels	16 Bit Serial Digital Channel	1	1
	High Speed Interface	0	0
Monitor Channels	Spacecraft Powered Thermistors	0	0
	Bi-level Channels	0	0
	Analog Channels	0	0
Timing Channels	High Frequency Clock	0	0
	Broadcast Pulse	1	1

The telecommand interface circuit and the telemetry interface circuit are shown in Figure 2.1-2 and Figure 2.1-3, respectively.

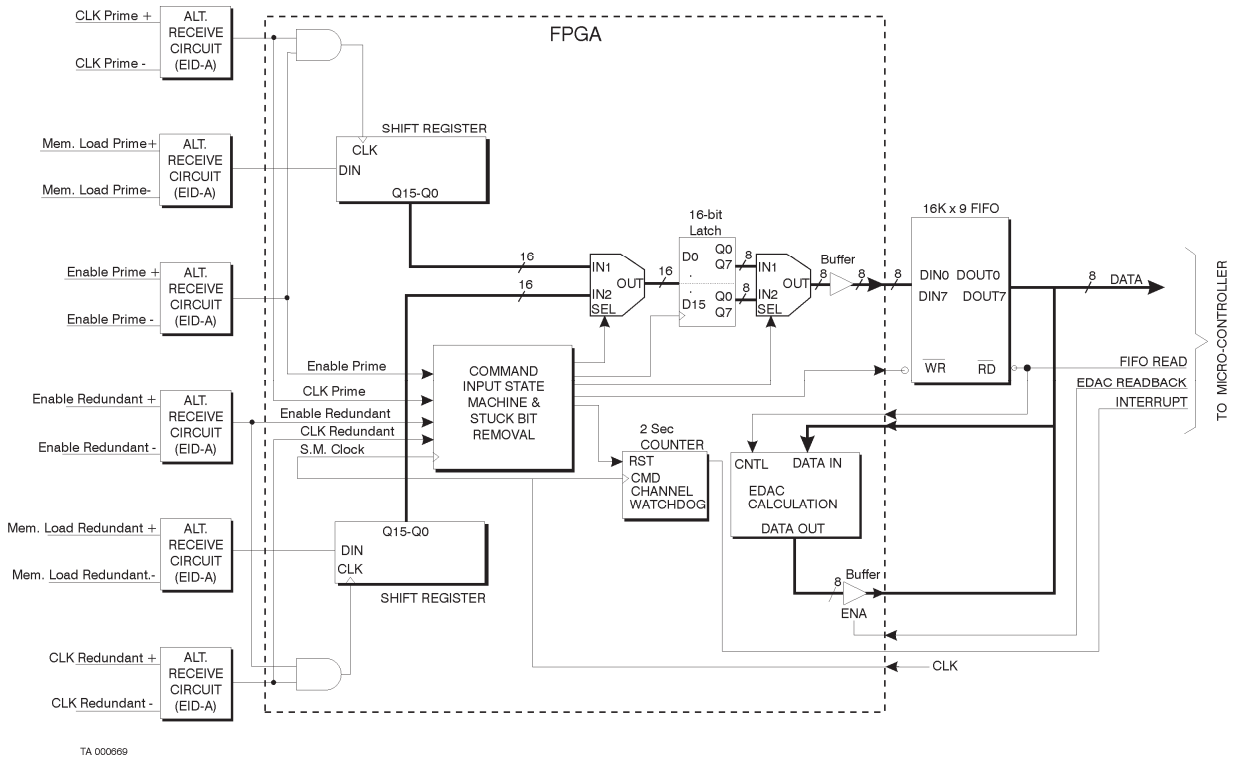

Figure 2.1-2. Alice telecommand interface circuit.

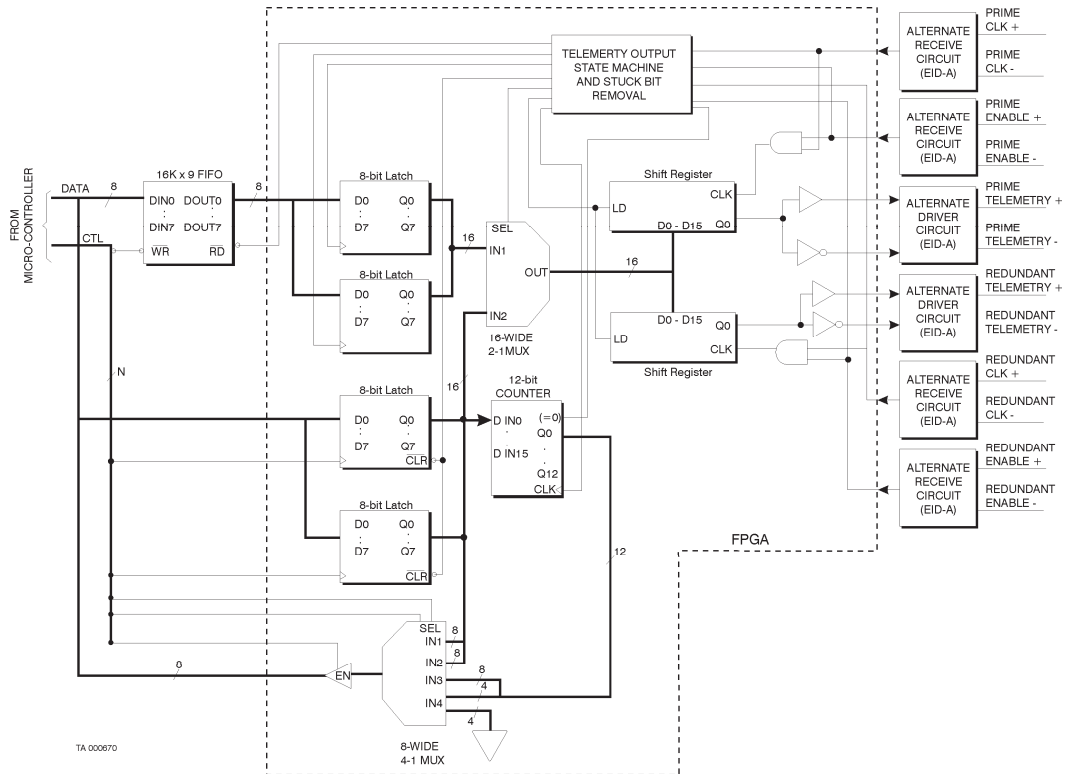

Figure 2.1-3. Alice telemetry interface circuit.

### 2.1.4 Instrument Heaters

*Alice* has two sets of redundant heaters on the optics (OAP mirror and grating) that allows for decontamination of the optics during flight as required. These two heaters are controlled by the *Alice* C&DH electronics. In addition to these two heater sets, a non-ops “survival” heater is located on the side of the instrument housing that is controlled by the spacecraft.

### 2.1.5 Instrument Thermistors/Housekeeping Sensors

Table 2-5 shows the location of all *Alice* thermistors and other housekeeping sensors.

Table 2-5. *Alice* thermistors and other housekeeping sensors.

Description	Mnemonic	Location	Control	RMIB ID
OAP Mirror Thermistor (2)	HkMirrorTempPri HkMirrorTempSec	OAP Mirror Bracket	Alice	NALD1001, NALD1002
Grating Thermistor (2)	HkGratingTempPri HkGratingTempSec	Grating Bracket	Alice	NALD1102, NALD1201
Detector Housing Thermistor	HkDetHousingTemp	Detector Housing	Alice	NALD1802
Detector Electronics Thermistor	HkDetElecTemp	Detector Electronics	Alice	NALD1801
C&DH Thermistor	HkCdhElecTemp	C&DH Electronics	Alice	NALD1901
Instrument Housing Thermistor	HkInstHouseTemp	Instrument Housing	Alice	NALD1902
Instrument Housing Thermistor (2)	ScAliceTempReference-1 ScAliceTempReference-2	Instrument Mounting Foot	S/C	NTSA0068, NTSA0188
HV Arm Indicator	HkHvOn	C&DH Electronics	Alice	NALD0101
Detector Stim Pixel indicator	HkDetStim	Detector Electronics	Alice	NALD0102
Detector Analog Count Rate	HkCountRate	Detector Electronics	Alice	NALA0002
Image Acquisition Mode	HkAcqMode	C&DH Electronics	Alice	NALD0103
Detector Door Open Status	HkDetDoor	Detector Housing	Alice	NALD0105
Aperture Door Open/Close Status	HkApDoor	Instrument Housing	Alice	NALD0106
Mirror Heater Power On	HkMirrorHtrOn	OAP Mirror Bracket	Alice	NALD0109
Grating Heater Power on	HkGratingHtrOn	Grating Bracket	Alice	NALD0110
HVPS HV Set Point	HkHvSet	C&DH Electronics	Alice	NALD0501
HVPS MCP Voltage	HkMcpV	HVPS	Alice	NALD0502
HVPS Anode Voltage	HkAnodeV	HVPS	Alice	NALD0701
HVPS Strip Current	HkStripI	HVPS	Alice	NALD0802
Discriminator level readback	HkDiscriminator	C&DH Electronics	Alice	NALD1301
Operating State	HkOperatingState	C&DH Electronics	Alice	NALD0107

## 2.2 Software (DRD 28.1)

This section of the document contains a description of the *Alice* instrument Flight Software (AFS). A detailed description of the Telemetry and Telecommand formats can be found in Section 6.

### 2.2.1 Software Overview

The *Alice* Flight Software (AFS) controls the *Alice* instrument. AFS controls and monitors the instrument hardware, and communicates with the spacecraft through the telecommand and telemetry interfaces.

AFS executes on an 8051 compatible microcontroller. Because the microcontroller runs at a low frequency to save power, AFS is designed to be as simple as possible. As much as possible, the hardware has been designed to handle processing related to data acquisition and packet buffering, in order to reduce the computing load on the microcontroller.

Because of the simple design, *Alice* software can only perform one function at a time. Therefore it does not continuously acquire and produce science data in a streaming fashion. Rather *Alice* performs a data acquisition while producing no data, then dumps the data in a burst fashion when the acquisition is complete. This acquire-dump cycle can be commanded by a single telecommand. Except for safety monitoring, *Alice* does not perform any operations without being explicitly commanded to do so. But the acquire-dump command allows for the specification of a number of repetitions of the specified acquire-dump cycle and execute for a long period. (up to  $255 * 65535$  seconds = 193 days). This Multiple Acquire Dump telecommand allows for the commanding of complete science observation sequences with only a single telecommand. In addition to, and in parallel with, science operations, housekeeping data can be generated on a selectable periodic basis.

Telecommands that could potentially cause damage to *Alice* if used incorrectly or loss of already acquired science data are designated "critical". Critical telecommands require a two-step commanding process, where the critical telecommand is followed by a telecommand confirming the critical telecommand. If the critical telecommand is not confirmed within a timeout period, then it is expired and cannot be executed. The critical commanding process is defined to prevent errors when operating *Alice* in the lab and in flight. During mission operations, we do not expect that there would be any round-trip confirmation of critical telecommands to the ground. Rather we would simply include the confirmation telecommand following the critical command in the timeline.

### 2.2.2 Autonomy Concept

Almost all of *Alice* operation is not autonomous but rather in direct response to a command. *Alice* software does however implement a safety-monitoring algorithm. The following safety conditions are monitored continuously whenever *Alice* is operating:

- Dust flux level
- Bright object
- ROSINA pressure trend
- ROSINA pressure alert
- HVPS anomaly
- Temperature sensor limit

*Dust flux level* – *Alice* receives GIADA dust messages via the information distribution service. If the level rises above a configurable limit, then *Alice* safety is triggered.

*Bright object* - if the detector count rate goes above a configurable limit, then *Alice* safety is triggered.

*ROSINA pressure alert* - *Alice* receives ROSINA pressure information via the information service at intervals controlled by ROSINA or the spacecraft. If the instantaneous ROSINA pressure level is above a configurable threshold, then a pressure alert condition exists and *Alice* safety is triggered

*ROSINA pressure trend* – If the instantaneous ROSINA pressure level is below the configured threshold an expected safe time is calculated based on the ROSINA pressure and the ROSINA pressure trend. Based on this safe period and a configurable maximum prediction limit a timer is set. When the timer expires before a new ROSINA pressure message is received, *Alice* safety will be triggered.

*HVPS anomaly* - if any of the detector voltage or current readings go out of limits, then *Alice* Safety is triggered.

*Temperature sensor limit* - if any of the *Alice* temperature sensors goes above an upper limit, then *Alice* Safety is triggered.

The occurrence of any of these six conditions described above causes *Alice* to autonomously perform a safety shutdown. During the safety shutdown, *Alice* high voltage is turned down and the aperture door closed (configurable); a triggered safety does not affect any flag, rate, or parameter setting. Operations can only be resumed after all of the conditions have been absent for a configurable period of time. Safety monitoring is always active and as long as the safety condition exists the timeout timer will be reset to the timeout period. The behavior is slightly different depending on safety condition. For temperature safeties, after triggering the safety condition most likely will persist for some time since temperatures don't change that quickly; for a HV or countrate related safety the safety will disappear as soon as HV is deactivated as part of the safing so the countdown will likely start immediately; for the pressure and dust alarms the safety is evaluated one time for each external message that is received, so each time an out of limit value is received from ROSINA or GIADA the timeout timer will be reset. Each individual condition can be masked upon command from the ground. A condition that is masked is not considered when deciding to perform a safety shutdown. Finally, the safety shutdown can be completely overridden allowing *Alice* to operate even in the presence of a safety condition.

When a safety condition occurs, *Alice* generates an event packet and is commanded to the safe state if the safety is not masked. The safety status is reported in the HK data. No data are lost when the safety shutdown occurs, dump operations may still continue or the data can still be retrieved using a separate dump command. After a safety is triggered, *Alice* is designed to not execute acquisition commands until the safety timeout (default is 600 seconds). However, *Alice* still will generate "failed" events from those non-executed commands that occur during the safety period. Only when the safety condition disappears and the safety timeout period expires can new acquisitions (which possibly open the aperture door and activate the high voltage) be started. This may even be a successive acquisition operation within a single (still active) MultipleAcquireDump telecommand. Depending on the specific configuration of timeout period, number of acquisition cycles, and cycle timing, this mechanism may be used to implement a strategy that weights instrument safety versus science return. During the mission, this strategy may change from very cautious to more aggressive when the instrument becomes better known.

### 2.2.3 Software Maintenance Approach

There are two ways to access and modify *Alice* software: changes to the parameter file, and patching of the code memory in EEPROM, as described below.

All of *Alice* important operating parameters are kept in a "parameter file" which is an area of memory, which holds constants and parameters used by the software. The contents of the parameter file are shown in the context packet definition. They can then be changed at any time by command. Each time *Alice* is shut down normally, the entire parameter file is saved to the spacecraft using the context service. Whenever *Alice* is started, the default contents of the parameter file are loaded from ROM. In the nominal startup sequence *Alice* will receive the most recent parameter file from the spacecraft via the context service. This is the normal way that *Alice* software is modified during the mission. This type of modification qualifies as a level 1 change according to EID-A Section 6.5.3.

The second way that *Alice* software can be changed is through a memory patch. This qualifies as a level 3 change and would only occur in contingency situations. Memory patching for *Alice* is performed via the memory management service.

The available code space for the *Alice* flight software is 32 kbytes, currently 98.7% of this code space is used in one large executable segment. Unless local patches can be used to correct software functionality, for instance to patch local variables in the code space, a full memory patch may be needed.

*Alice* has two types of non-volatile memory, PROM and EEPROM. These memory type share address space such that only one is accessible for execution at one time (EEPROM is always accessible in data space). When *Alice* hardware is booted, code execution always starts from PROM. This is where the *Alice* nominal flight software is stored. There are available multiple pages of EEPROM that can be overlaid over the PROM. Every EEPROM page will initially contain a copy of the nominal flight software. If a patch becomes necessary, one or more of these EEPROM pages will be modified as needed by using the memory service. Then by use of a private telecommand, *Alice* can be commanded to switch to execute from the patched EEPROM copy rather than the EEPROM. If it becomes necessary to always operate *Alice* with a patched copy of the code, then a modified startup OBCP can be used to always issue this command when *Alice* is started.

Note that since launch, the *Alice* EEPROMS have been updated with new versions of the code, so standard procedure is to operate *Alice* from EEPROM (not PROM, except for special cases, such as software updates). For more information on the current and previous version of the flight software code see Sections 2.2.5 and 3.1.11.

*Alice* also supports dumping and checksumming of memory, again via the memory management service. A memory dump would only be performed in an extreme situation where there was no other way to diagnose a problem. Memory checksumming may be used to occasionally verify the contents of code memory, or to verify proper loading of a patch.

The addressable non-volatile memory size is 32 kbytes. As described above, this memory space can be overlaid with PROM (the default) or one of four EEPROM memory pages. The entire *Alice* program must fit within the 32k limit. The available data memory size is 32 kbytes. In addition, *Alice* also has memory mapped I/O and control registers, and a paged window for access to the 64 kbyte acquisition memory. The *Alice* memory map is shown in Figure 2.2-1.

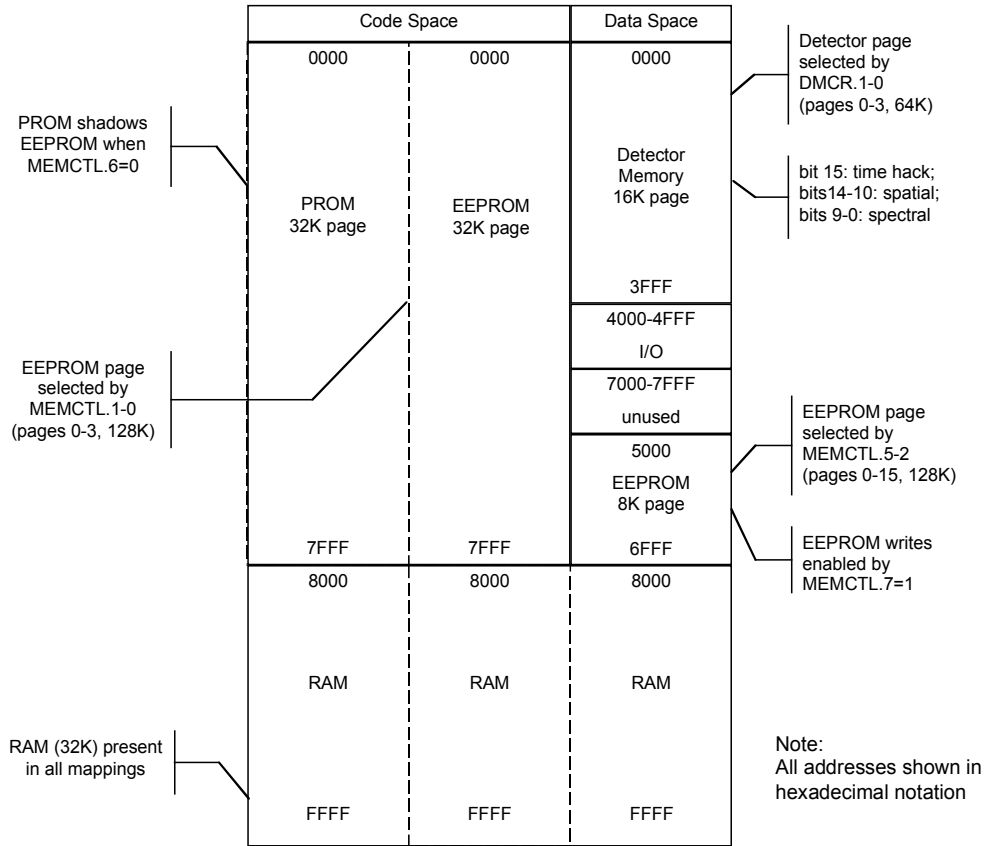

Figure 2.2-1. Alice memory map.

For purposes of the memory management service, 4 memory types are defined, all with 16-bit access. The types and address are as follows:

- 40 code, 0000-7FFF (used for dumping/checking code memory)
- 41 eeprom, 0000-FFFF (for patching and dumping eeprom, organized as four separate code pages)
- 42 detector, 0000-7FFF (for direct access to acquisition memory)
- 43 data, 0000-7FFF (for access to RAM and I/O)

For performing checksums, Alice uses the 8-bit XOR rotate method to enable operation together with the ROSIS. The same method is used in the Alice flight release

## 2.2.4 Data Delivery Concept: Application Process IDs (APIDs)

Alice supports three data acquisition modes, however as these modes operate exclusively, Alice will require only 1 Process ID. As allocated in EID-A Section 2.8 the value 92 (decimal) will be used.

Alice only generates science data when requested by the MultipleAcquireDump telecommand. In the dump phase of this command the data is dumped in a burst mode (acquired data is transmitted from buffer



until buffer is empty). Therefore the enable and disable science telecommands (service 20) are not meaningful for *Alice*. *Alice* accepts these two telecommands but they are non-functional. They return execution success but do not affect science data generation.

*Alice* has one defined housekeeping packet (SID=1), which has a data field size of 46 octets. Housekeeping generation begins when an enable housekeeping telecommand is received or within approximately 60 seconds after startup if no enable command is received. When enabled, housekeeping packets are generated at a configurable rate. The default rate is one packet per 30 seconds, but this can be modified by changing an operating parameter in the parameter file.

*Alice* also has defined a supplemental diagnostic data packet. This packet is defined as a science packet so it is not visible to DMS HK processing algorithm. This packet is produced at the same time as a housekeeping packet if it is enabled. It is enabled or disabled by a parameter in the parameter file. In normal operation generation of this packet is disabled.

*Alice* makes use of the event service both for notification of actions within the instrument, and to indicate error conditions. Event packets are generated for the following reasons:

1. At software startup, with self test information (normal)
2. When the door moves (normal)
3. When the high voltage is changed (normal)
4. When the door does not move as expected (warning)
5. When there is a correctable error reading the parameter file (warning)
6. When there is a non-correctable error reading the parameter file (on-board)
7. When there is a safety condition (on-board/ground configurable)
8. When the acquire phase of the MultipleAcquireDump telecommand starts/fails (normal/warning)

### 2.2.5 Timing Requirements

The most important consideration regarding timing is the correct time tagging of each UV spectral image. Using the time-tag, we can derive the instrument look angle for each image.

Whenever *Alice* is powered on from a powered off state, an update of *Alice*'s internal time of day clock shall take place in accordance with Section 2.8.1.8 of EID-A. During times when *Alice* is powered on and operating, the instrument's internal time of day clock shall be updated when commanded by the OBDH time synchronization command. The required absolute accuracy of the spacecraft time of day updates is to plus-or-minus a few seconds. However, the scheme used by *Alice* shall provide for much better accuracy. The *Alice* internal clock will keep relative time between updates at a maximum accuracy of 1/256 s to accommodate time-binning of rapid detector readouts during observations of fast temporal events.

However, note that since the internal clock is not synchronized when *Alice* is first powered on, the first packet generated, the *Alice* power-on event packet, will contain unsynchronized time in the time field. We expect that *Alice* will receive a time update shortly after this happens. It is not possible for *Alice* to receive a time update packet prior to generation of the power-on event packet. During normal operation, *Alice* requires a time update command every 30 minutes in order to keep the internal clock synchronized within acceptable limits (< 15 ms).

Since power-on event packet always has an unsynchronized time field, it may complicate DMS handling of these packets. Under normal conditions when *Alice* boots as expected, the contents of these packets are not important and they can be discarded or routed in any way convenient to DMS. However if *Alice* ever fails to boot normally, then the *Alice* team will request that the contents of the power-on

event packet be made available (if it is produced) for the purpose of providing diagnostic information about the *Alice* boot up process.

*Version 2.03 (PROM) flight software*

During science data acquisitions (execution of MultipleAcquireDump telecommand) *Alice* was ignoring any time synchronization requests in order not to influence the timing of the acquisition function. The received synchronization requests, though, will be acknowledged by *Alice* if requested. During commissioning it was discovered that the instrument internal clock started to lag behind during long acquisition sequences, where multiple time synchronization operations were ignored. Measurements showed a (unsynchronized) internal clock drift of about -43.2 sec/day. Analysis showed that this was caused by a hardware error in the *Alice* clock circuitry instead of dividing the oscillator frequency by 4000 it was divided by 3998, hence the interrupt rate was  $4000/3998 = 1.0005$  sec or 0.5 ms after the desired 1 second. Over a whole day this predicted error accumulates to a clock drift (lag) of 43.2 seconds per day.

This drift caused operational problems as the instrument reports earlier times in command acknowledgements and the ground system will report a warning when command acknowledgements are more than 3 seconds before the planned command execution time.

*Version 2.04 flight software*

In order to correct the clock problem a update for the flight software was developed. With respect to the observed clock problem in version 2.03, this version includes two main changes:

- Clock synchronization is now accepted and processed unconditionally, this removes the possibility of ignoring multiple clock synchronization operations during long acquisitions, testing showed that this activity does not influence the acquisition operation. This will ensure that every 30 minutes the clock is resynchronized, irrespective of the ongoing operation.
- Correction of the incorrect hardware divider factor, instead of incrementing the internal clock by one for every timer interrupt, the clock is now incremented by  $1+1/2048$  (~1.00049). After this correction, the remaining clock drift was measured on the spacecraft; without any synchronization operations, a drift value of 0.7 sec/day was measured.

With the 30-minute synchronization period, this means that the *Alice* instrument clock will never drift more than 15 ms from the actual spacecraft time.

*Version 2.05 flight software*

This new release includes the addition of a special variant of the pixel list acquisition function that is optimized to perform successive pixel list acquisitions with minimal time in between the active acquisition operations. This operating mode optimizes the acquisition of small pixel list acquisitions and will be referred to as ‘Perpetual Pixel list capability’. This mode can be used to perform pixel list acquisitions with minimized gaps in between the separate acquisitions. It assumes that the spacecraft data handling system can on average keep up with the generated data and the instrument internal FIFO is sufficient provide some buffering of the generated TM packets. This ‘Perpetual Pixel list’ capability is a software attempt to mimic the PERSI-*Alice* continuous pixel list acquisitions within the limitations of the existing software structure. The changes for this mode include:

- Optimize the instrument internal data transfer and formatting of the pixel list science packets for one TM packet pixel list acquisitions (less than 1931 events);
- More frequent check of the end condition for pixel list acquisitions from once per second to five times per second;

- Optimize instrument internal data transfer to send the generated TM packets to the 16 kbyte TM FIFO that hold the generated TM packets;
- Special MAD cycle specification that will continue the MAD cycles until explicitly commanded to stop.

In addition to the functional extension of the software some small changes/corrections were made to correct earlier found problems:

- SPR-19: ‘Door Life Test writes beyond result buffer’ was corrected;
- SPR-20: PAD field not copied for service #1 responses was corrected.

### 2.2.6 Boot Sequence

When *Alice* is started, it carries out the following boot sequence:

1. Run internal startup self test (about 20 seconds)
2. Enter safe state
3. Transmit power-on event packet
4. Wait for 40 seconds, or enable HK command
5. Send first HK packet
6. Continue sending HK at default rate

During the time of the self test (approximately 20 seconds after power on) *Alice* will not accept any telecommands. Once *Alice* sends the power-on event packet, it is then capable of receiving telecommands. If an enable HK telecommand is sent, then *Alice* will begin generating housekeeping data right away. If no enable HK telecommand is received, then HK will be automatically enabled 40 seconds after the power-on event packet was sent. Normally *Alice* expects to receive a time update shortly after completion of the power-up self-test, but this does not affect the boot sequence or timing, only the time tagging of telemetry.

If *Alice* is turned off, then a duration of at least 1 second should be observed prior to turning *Alice* back on to allow for hardware discharge time.

### 2.2.7 Instrument Operating Modes

To avoid confusion, first it is necessary to define what is meant by modes and states. For the Rosetta project, the term “mode” as applied to the instruments are general modes, and is used for modeling data rates, power consumption, and for error checking that commands can be performed (such modeling is done, e.g., in the EPS); these modes during cruise phase are *off*, *safe*, *checkout*, *Acquire*, *Stand\_by*, and *Dump* (see Figure 4.1-1 in Section 4), and during comet escort phase were changed to: *off*, *safe*, *operational* (in other words, all *Alice* states that are not *off* or *safe* are considered to be *operational*, which would include the *Alice* states: *Acquire*, *hold*, *checkout*, *dump*, and *safe-dump*). However, within the *Alice* project, the term “mode” is used to describe *data acquisition* modes of the instrument such as *histogram*, *pixel list*, and *count rate*. Finally, also within the *Alice* project, the term “state” is used to refer to the operating state of the instrument (listed below), which is part of the instrument configuration, and is more directly related to the Rosetta project’s term “mode”.

## Instrument Acquisition Modes

*Alice* acquisition modes are not directly related to data rates. This section describes the acquisition modes as they relate to software. *Alice* science operations and objectives are discussed in more detail in Sections 1.3, 3.2 and 6.

The three acquisition modes are: *image histogram*, *pixel list*, and *count rate*. The modes are all similar in the sense that during an acquisition the detector is acquiring photon events, and these events are accumulated by *Alice* in the acquisition memory over a period of time (the integration time, or acquisition time). In every mode, the detector electronics always produces a 2-D address indicating where on the detector the event occurred. It also produces a count of total events. The difference between the modes is the way in which the data is stored.

### *Image Histogram mode*

In image histogram mode, the event address that is generated by the detector electronics is used as an index into the acquisition memory. The value at that memory location is then incremented. The result over time is a histogram of the photon events received by the detector. The value at each address in the acquisition memory indicates the intensity at that detector location. The data storage operations in this mode are performed by hardware, once configured by software. The software only intervenes at the beginning and end of the acquisition (or if a problem is detected). The data dumped from the histogram mode (once completed) consists of part or all of the memory array. The data may also be collapsed into bins as it is sent down to reduce overall data quantity; the time required for this collapse is very short, and does not add significant overhead operations.

### *Pixel list mode*

In pixel list mode, the event addresses that are generated by the detector are stored sequentially in the memory array, as in a list. In addition to the detector events, a time-mark value is also inserted into the list on a periodic basis. The result is a list of all detector events during the integration period along with the time binning information. The data storage operations in this mode are performed by hardware once configured by software. The software only intervenes at the beginning and end of the acquisition (or if a problem is detected). The data dumped from the pixel list mode (once completed) consists of the list of pixel events and integrated time marks. The data dump can also be filtered so that only those events that occurred within a certain region of the detector are included in the data dump.

### *Count rate mode*

In count rate mode, only the total event count within a given (user-defined) time interval is stored on a regular basis. The actual event addresses are ignored. The event count is stored sequentially in the memory array, as in pixel list mode, except that the value stored in the list is only the total count for each time interval, with no event location information and no time hacks. This mode provides a record over time of the variation in count rate observed by the detector. Unlike the other two modes where the acquisition is performed by hardware, in this mode the acquisition is implemented in software. The software is programmed to read the total count from the detector on a periodic basis and store that count in sequence in the acquisition memory. The data dumped from the count rate mode consists of the list of event counts. Note that there is also an analog count rate reported in the HK data (Section 3.1.8).

## Operating states of the *Alice* instrument:

AFS implements a set of states to control the instrument operation. At any given time, the software in the *Alice* instrument is operating in one of several states. *Alice* makes transitions between states according to telecommands and the results of internal safety monitoring procedures. The current operating state of *Alice* at any time defines what the instrument is doing, what commands are allowed, and the related data flow. AFS implements the following states:

- safe
- safe-dump
- checkout
- hold
- acquire
- dump

First a detailed description of these 6 states will be given and the mode transition diagram that describes the operations of the instrument. In housekeeping telemetry the instrument will report one of these six states. Following this a simplified mode diagram will be presented that shows the basic modes that determine the data generation.

### Safe State

The safe state is the default state for the software whenever *Alice* is first powered on or restarted. It is also the state entered whenever something occurs on-board to cause the instrument to safe itself. In the safe state the high voltage power supply is shut down (either idle or off) and the aperture door is closed up on entry into the safe state (configurable). Command acceptance is limited so that the instrument cannot be activated while in the safe state (except that acquisition commands are accepted).

### Safe-Dump State

The safe dump state provides a means of dumping science data while the instrument is shut down for safety reasons. This state is entered from the safe state upon receipt of a dump data telecommand. While in this state, *Alice* is dumping science data to telemetry. Upon completion of the data dump *Alice* will return to the safe state.

### Checkout State

The checkout state is entered by command and is used to perform checkout and general diagnostics of the *Alice* instrument. All commands are accepted from this state. This state is not normally used during routine science observations.

### Acquire State

In the acquire state the *Alice* instrument is acquiring science data in one of the three acquisition modes (histogram, pixel, count rate). This state is entered during the acquisition phase of the MultipleAcquireDump command, and it remains in this state until the acquisition is complete or the acquisition is stopped prematurely by command or due to a safety-monitoring event. Upon normal completion of an acquisition, *Alice* will transition to the hold state from the acquire state.

### Hold State

While in the hold state, *Alice* is holding a set of science data, awaiting further steps or commands to either resume acquisition or dump the data to telemetry. While in the hold state, the instrument configuration is not changed. The door and HVPS remain in their previous condition.

### Dump State

The dump state is used to dump science data. This state is entered by in the dump phase of the MultipleAcquireDump command. It remains in this state until the data dump is completed or cancelled. Upon normal completion it returns to the hold state.

Note that this design means that *Alice* can essentially only perform one high-level function at a time. It is either acquiring data or dumping data, but not both. Lower level functions such as command and telemetry processing, and safety monitoring, are still performed in all states.

Refer to Figure 2.2-2 for a state diagram showing the transitions between the *Alice* operating states.

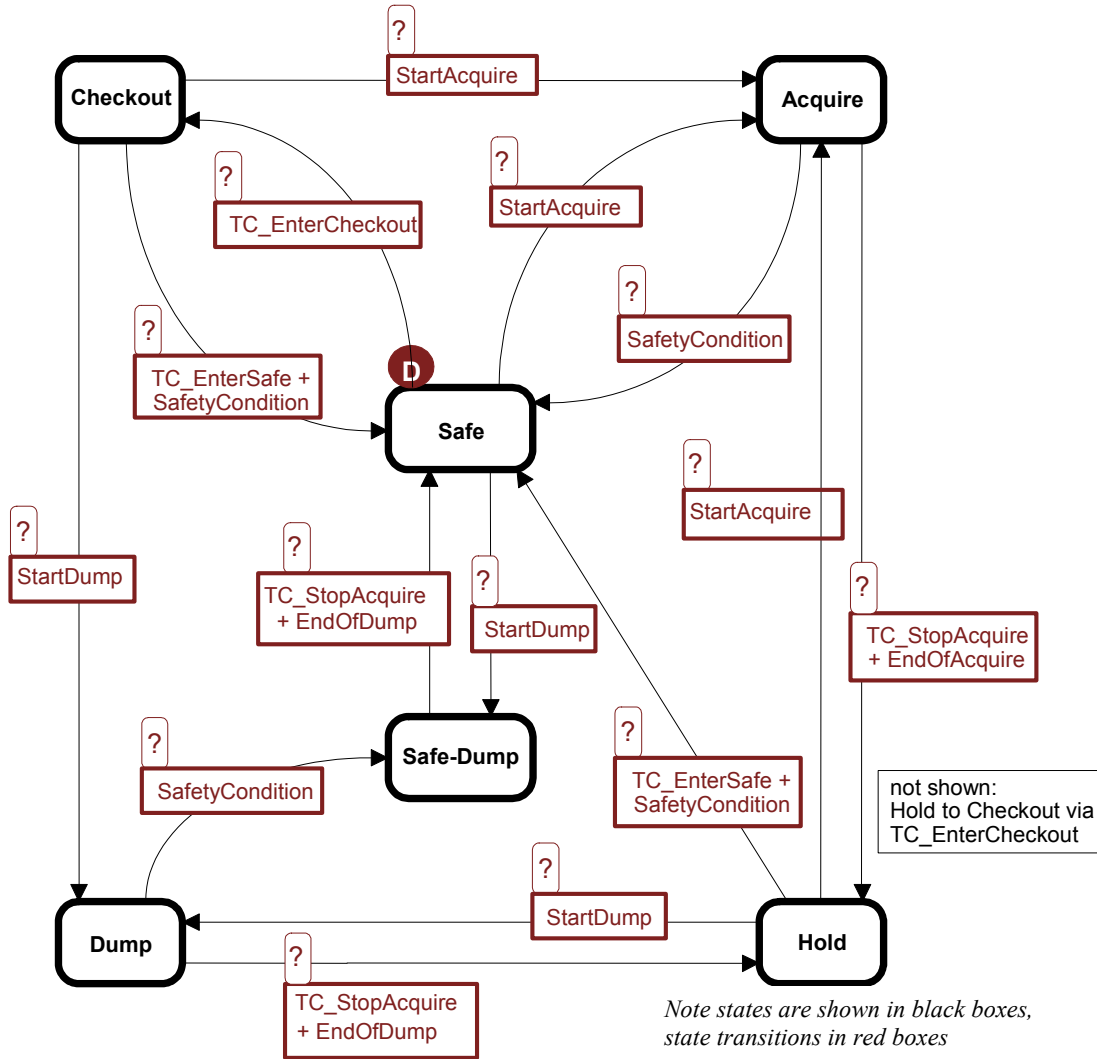

Figure 2.2-2. The Alice software operating state diagram.

## 2.3 Budgets (DRD 12.2)

### 2.3.1 Mass

*Alice* has a measured mass of 3.06 kg.

### 2.3.2 Operating Power (Alice EID-B, § 2.4.3)

Power consumption for the *Alice* instrument is listed below in Table 2-6. The numbers for end-of-life (EOL) are best estimate values. Table 2-7 gives the beginning-of-life (BOL) power breakdown per instrument subsystem.

Table 2-6. Alice Power Consumption

Experiment Interface	Average Power (BOL) [W]			Predicted Average Power (EOL) [W]			Long Peak Power [W]	Short Peak Power [W]
	M o d e			M o d e				
	1	2	3	1	2	3		
+28 V Power Interface	3.6	4.0	6.0	3.8	4.2	6.3	10.4 (*)	7.5

mode 1: Safe Mode (with HVPS output disabled)  
 mode 2: Operating (detector and HVPS on and data collection proceeding)  
 mode 3: Decontamination Operation (Operating + Heaters on)  
 (\*) 2 s (aperture door opening time)

Table 2-7. Alice Power Breakdown per Subsystem

Component	Power Levels (Watts)		
	Mode 1	Mode 2	Mode 3
Detector electronics	1.1	1.3	1.1
HVPS	0.3	0.5	0.5
C&DH Electronics	1.0	1.0	1.0
LVPS	1.2	1.2	1.2
OAP Heater	0.0	0.0	1.1
Grating Heater	0.0	0.0	1.1
Total Power	3.6	4.0	6.0
Mode 1: Safe Mode			
Mode 2: Operating--Data Collection			
Mode 3: Optics Decontamination (operating with heaters on)			

### 2.3.3 Data Rates (Housekeeping and Science)

The instrument generates two separate data streams: a periodic stream of housekeeping and an on-demand stream that occurs in a single burst at the completion of an acquisition. Both data streams are inserted into an output FIFO (16 kbyte) that is periodically (nominally every 8 seconds) read by the spacecraft.

#### Periodic data

The instrument will, after power up, start generating housekeeping packets at the rate defined in the parameter table (parameter #34, HKRATE; see table in Section 6.5), nominally one packet per 30 seconds. As long as *Alice* remains powered on the generation of housekeeping packets continues but the rate may be changed by telecommand. In addition the instrument can be commanded to add a diagnostic package to the stream of periodically generated packages. This package will be generated at the same time and rate at which housekeeping packages are generated. The rate of the periodic packets can be selected by telecommand and may be between 1 and 255 seconds. The size of both the housekeeping

package and diagnostic package are fixed so once a packet rate has been selected the resulting data rate can be calculated. Both housekeeping and diagnostic packets are fairly small with respectively 46 and 60 data bytes. Table 2-8 shows some examples and the resulting data rates:

*Table 2-8. Periodic data generation rates*

<b>Data Mode</b>	<b>Packet Rate</b>	<b>Data Rate HK packets only</b>	<b>Data Rate HK + Diagnostic packets</b>
Nominal (startup)	30 sec	12.3 bits/sec	28.3 bits/sec
High rate	5 sec	73.6 bits/sec	169.6 bits/sec
Low rate	240 sec	1.5 bits/sec	3.5 bits/sec

On demand data

All other data generated by the *Alice* instrument is generated on demand only, meaning that only after a specific solicitation (telecommand) data packets will be generated. This category consists of the science data that is generated at the end of an acquisition exposure but also some special data streams fall in this category like memory dumps and event packages. Event packages are very small and are therefore only small contributions to the overall data rate. Memory dump packages are only used during non-nominal operations and even then the amount of memory that can be dumped from the *Alice* instrument is very limited so this also doesn't need to be considered for the nominal data rate calculations. This leaves the science data that is generated at the completion of an exposure. The resulting data rates for these depend on the specific kind of observations (acquisition mode) performed, the dump selections and in some cases the observed objects.

*Alice* data collection consists of a long (nominal between 10 seconds and about 30 minutes) data acquisition, during which no science data is produced, followed by a brief period of time during which the acquired *Alice* data is transmitted (dump). *Alice* includes a simple mechanism by which a variable delay can be inserted between packets of a science data dump. This parameter is specified for each separate dump operation. This allows for a simple control of the maximum output data rate, but still the resulting data rate depends on specific science data being dumped, actual polling rate and this specified delay. First the data dump operation is described, initially the simple case is described where the full acquisition buffer is dumped, later available selection methods will be described that allow for the optimization of the dumped data with regard to a limited downlink capability. For each acquisition up to eight dump selections can be specified that dump selected parts of the acquired data.

When *Alice* performs a science data dump, some or all of the science data is dumped as one or more science telemetry packets (maximum data size 3994 octets each). As described above, these dumps always happen like a burst at the end of the exposure. First, we first assume that maximum amount of data is being dumped. For all three acquisition modes, the acquisition buffer can hold up to 32 kword (16-bits) of data and after packaging this results in up to 19 or 17 telemetry packets depending on the ancillary data which is acquisition mode dependant. If less than the full data are dumped, then the duration will be correspondingly shorter. When the data are dumped, 1, 2, or 3 science packets are dumped per spacecraft polling period. All of the dump rates assume an 8 second polling interval. If *Alice* is not polled at the assumed rate, then no data is lost, but the dump will take longer with a lower effective data rate. As described one of the parameters for a data dump is the dump delay, which allows for the reduction of the generated data rate. This results in the following data rates (see Table 2-9) for the full 19 packet histogram data dump (in total 72452 bytes of data):



Table 2-9. Example dump durations and data rates

Dump	Selected Dump Delay	Dump Duration	Average Data Rate
Dump Normal	0	~70 seconds	~8.28 kbit/sec
Dump Slow	40	~140 seconds	~4.14 kbit/sec
Dump Extra Slow	160	~280 seconds	~2.07 kbit/sec

The maximum science data size for *Alice* has been set to 3994 bytes giving a maximum *Alice* science packet size of 4010 bytes. This will allow 3 science packets to be placed in the output buffer (FIFO) and leave room for a few protocol packets. The resulting effective downlink rate depends on the spacecraft polling rate. The simple *Alice* processor may take up to about 3 seconds to format a science packet (depending on the specific science mode). If the spacecraft could only support a nominal polling rate of 8 seconds, *Alice* could fill the output FIFO to fit the maximum 6144 words block size. So at low polling rates this will give the best available downlink rate.

One single private telecommand, MultipleAcquireDump (MAD), is used for the nominal *Alice* science operations. Parameters in this command specify the acquire dump cycle that forms the basis of all *Alice* science operations. The command allows for the specification of three different science acquisition modes:

- acquire histogram mode
- acquire pixel list mode (with two termination options)
- acquire count rate mode

Each of these acquire operations store the acquired science data in the internal *Alice* memory. Once the acquisition is complete, then a dump operation specified in the same MAD telecommand is used to transmit the acquired science data via the telemetry interface. The MAD command is very flexible, allowing many possible combinations. It is possible to resume an acquire following a dump, adding to the previous data without erasing it. It is also possible to perform multiple dumps on the same data for the purpose of looking at more than one "window" or perhaps by collapsing the data in different ways.

The acquire function has the following parameters defined:

- integration time (duration of acquisition, in time or events)
- aperture door open/closed
- detector stim on/off
- clear memory (at the start of the acquisition)

These parameters determine how long the acquisition runs until it is complete, and also control the behaviour of the instrument door and detector stimulation while the acquisition is in progress. The clear memory parameter determines if the acquisition memory is erased before the acquisition is started.

The dump function may specify up to 8 different 'dump windows' to be transmitted after completion of the acquire function. Each specified 'dump window' has the following parameters:

- filter window
- collapse factors

These parameters do not apply to all modes of data. The filter window is applied to histogram or pixel list data. Only detector events that occur within the specified "window" will be included in the data dump. This provides a means of looking at only a particular area of interest on the detector, thus reducing the amount of data sent in telemetry. The collapse factors are applied only to the histogram data. The acquired data is binned in spatial and spectral dimensions according to the collapse factors. Again this allows a means of reducing the volume of science data that must be sent via telemetry.

To limit the number of telecommands needed for nominal *Alice* science operations the MAD telecommand allows for the specification of a number of identical cycles. So after a single telecommand *Alice* will execute a specified number of the specified (identical) acquisition-dump cycles. This corresponds to the nominal planned science operations, which consist of a series of acquisitions using the same acquisition (and dump) parameters. Parameters will allow for the specification of:

- number of cycles
- time between cycle starts (or near continuous operation)

As *Alice* only produces science data on specific request, the enable and disable science telecommands are non-functional. In case of a problem, the private telecommand StopAcquire can be used to terminate any ongoing *Alice* science activity. This will also stop any science data dumps at the next available telemetry packet boundary. The acquired science data remains in the *Alice* internal memory and can be retrieved later using a separate dump action.

In the next two tables (Table 2-10 and Table 2-11) the science data production volumes are summarised. The first table specifies the base data volumes for each of the acquisition modes, these assume a full dump of all acquired data, the variations are the result of the different amounts of ancillary data that is included in each science dump. This table also lists the factors contributing to possible limitations in the base volume. The second table presents some more detail concerning the effect that mostly dump selection parameters have on the produced data amounts.

Table 2-10. Acquisition base data volumes

Acquisition Mode	Maximum Size Packets <sup>2)</sup>	Acquisition Limits	Selection
Histogram	72452 bytes 19 packets	commanded acquisition duration, amount of produced data is always constant	window and collapse factor
Pixellist (Timed)	68040 bytes 17 packets	commanded acquisition duration limits number of events captured, actual events captured depends on event rate of observed object	Window
Pixellist (Count)	68040 bytes 17 packets	commanded maximum number of captured events, therefore acquisition duration needed to acquire the amount of events may vary <sup>1)</sup>	Window
CountRate	67644 bytes 17 packets	maximum number of entries is commanded as is the duration of each slot, so acquisition duration and produced data can be calculated	None
<p>1) Due to the periodic checking of the limit values the actual acquisition may acquire slightly more events than commanded.</p> <p>2) Due to the different sizes of the annotation data in the science packets the number of science TM packets needed to store the results of an acquisition vary slightly (17 to 19 packets).</p>			

Table 2-11. Acquisition data volume modifiers

MAD parameter	Description	Effect on data volume
Acquisition Mode	One acquisition mode as listed in Table 2-10	Determines maximum base volume
Repeat	Number of acquisition/dump cycles	Linear multiplier for base acquisition volume, in version 2.5 of the flight software a special value is defined (255), this indicates that the repeat continues till explicitly commanded to stop.
Histogram		
WinLowSpectral, WinHighSpectral, WinLowSpatial, WinHighSpatial, CollapseSpec, CollapseSpat	Selected Spectral and Spatial window determine selected part of acquired image. Collapse factors allow for linear collapse in either dimension separately. The window selected in a dump specification lists both a spectral range (0-1023) a spatial range (0-31), and collapse factors. Both windowing and collapse result in reductions of amount of generated data. Specified acquisition duration does not influence the generated data volume since each acquisition produces one histogram.	
PixelList (time limited)		
WinLowSpectral, WinHighSpectral, WinLowSpatial, WinHighSpatial, Acquisition Duration, Hackrate	Number of captured events depends on brightness of observed object and selected hackrate until memory is filled:  $\text{data volume} = \text{time} * (\text{hack\_rate} + \text{photon\_rate})$ Post acquisition windowing will only select events that occurred within the selected window, but data volume reduction is unknown as distribution of captured event is a priori unknown.	
PixelList (count limited)		
WinLowSpectral, WinHighSpectral, WinLowSpatial, WinHighSpatial, Acquisition Counts, Hackrate	Total number of acquisition counts specifies directly the number of entries acquired, duration of acquisition will vary depending on the brightness of the observed object and the selected hack rate.  Post acquisition windowing will only select events that occurred within the selected window, but data volume reduction is unknown as distribution of captured event is a priori unknown.	
Count Rate		
Acquisition Slots Acquisition Interval	Number of acquisition slots is directly specified and determines the data volume, acquisition duration is the product of the number of specified slots (1-32767) and the acquisition interval (3 ms – 11.9 s) No further data selection is performed	

### 2.3.4 Non Operating Heaters (*Alice* EID-B, § 2.3.3.2)

No “non-operating” heaters are required during the hibernation phase of the mission.

### 2.3.5 S/C Powered Thermistors (*Alice* EID-B, § 2.3.3.4)

The S/C will monitor the *Alice* instrument baseplate TRP. The TRP contains 1 primary thermistor and 1 redundant thermistor.

### 2.3.6 Pyro Lines (*Alice* EID-B, § 2.5)

Each of the dimple actuators (for the detector door, the aperture door uncage, and the fail-safe door) requires 4 A of power during a 10 ms duration. See § 2.5.4 in the *Alice* EID-B for detailed information on the dimple actuator.

### 2.3.7 OBDH Channels (*Alice* EID-B, § 2.7.5)

The *Alice* instrument communicates with the OBDH telecommand and telemetry systems via two redundant three-signal interfaces per EID-A, Section 2.7. The clock signal is shared between the telemetry and memory load channels. See *Alice* EID-B, § 2.7.5 for further details.

## 2.4 Flight Data Archive Plan/Distribution Plan

The *Alice* data are sent to the *Rosetta* spacecraft, relayed to ground, and stored in the ESA Data Disposition System (DDS). These data can be sent (“pushed”) via FTP to computers at the *Alice* team institution in Boulder, Colorado at regular, pre-defined intervals (e.g., daily), and also can be directly requested from the DDS via FTP or web interface. The data are passed through instrument team software for calibration and analysis. These pipeline programs can be run interactively, but typically will be called by a UNIX shell script as the DDS regularly pushes *Alice* data.

The *Rosetta-Alice* data processing software consists of two parts:

1. **Collection.** Programs to read in the files containing the spacecraft data packets as obtained from the DDS, and combine them into self-contained and complete data files. This is performed by a C program called “LIMA”.
2. **Calibration.** Programs to process and calibrate the science data. Steps include flat fielding, deadtime correction, and applying wavelength and flux calibration. This is performed by a set of IDL programs called “MIKE”.

For more details of the calibration programs and the pipeline, see the “*Rosetta-Alice* Calibration Cookbook” document. All *Alice* data files (uncalibrated and calibrated science, calibration data, HK, event, memory dump, observing log, etc.) will be available to the public via the NASA PDS archive and the ESA Planetary Science archive according the *Rosetta* Archive Generation, Validation and Transfer Plan. The *Rosetta* Science Data Archive will be part of the Planetary Science Archive (PSA). The PSA is an online database implemented by ESA/RSSD and used for all of ESA's planetary missions. It is accessible via <http://psa.rssd.esa.int>. The underlying standard of the PSA is the Planetary Data System (PDS) standard from NASA. More information is available on the web site <http://pds.jpl.nasa.gov/>.

Following the *Rosetta* Archive GVT Plan, the *Alice* team will submit engineering and calibrated data files on a regular basis (after each “phase”, as defined in the mission plan) to the archive. To provide the correct format for the archive, auxiliary IDL programs will be run on the *Alice* data to create the appropriate PDS labels, directory structure, and additional informational files. Note that these programs do not change the actual *Alice* data files (FITS and ASCII files), but only create PDS-conforming label files that describe the *Alice* data files.

Reference documents:

- *Rosetta* Archive Generation, Validation and Transfer Plan (RO-EST-PL-5011);
- *Rosetta-Alice* to Planetary Science Archive Interface Control Document (8225-EAICD-01);

## 3 Experiment Operations

### 3.1 Operating Principles

#### 3.1.1 Instrument Overview

An opto-mechanical layout of *Alice* is shown in Figure 1.3-1. Light enters the telescope section through a 40 x 40 mm<sup>2</sup> entrance aperture at the bottom right of Figure 1.3-1 and is collected and focused by an *f*/3 off-axis paraboloidal (OAP) mirror onto the entrance slit and then onto a toroidal holographic grating, where it is dispersed onto a microchannel plate (MCP) detector that uses a double-delay line (DDL) readout scheme. The two-dimensional (1024 x 32)-pixel format, MCP detector uses dual, side-by-side, solar-blind photocathodes: potassium bromide (KBr; for  $\lambda < 1200 \text{ \AA}$ ) and cesium iodide (CsI; for  $\lambda > 1230 \text{ \AA}$ ). The measured spectral resolving power ( $\lambda/\Delta\lambda$ ) of *Alice* is in the range of 70-170 for an extended source that fills the instantaneous field-of-view (IFOV) defined by the size of the entrance slit. *Alice* is controlled by a Sandia Associates 3865 microprocessor, and utilizes lightweight, compact, surface mount electronics to support the science detector, as well as the instrument support and interface electronics. Figure 2 shows both a 3D external view of *Alice*, and a photograph of the flight unit.

#### 3.1.2 Optical Design

The OAP mirror has a clear aperture of 41 x 65 mm<sup>2</sup>, and is housed in the telescope section of the instrument. The reflected light from the OAP enters the spectrograph section, which contains a toroidal holographic grating and MCP detector. The slit, grating, and detector are all arranged on a 0.15-m diameter normal incidence Rowland circle.

The spectrograph utilizes the first diffraction order throughout the 700-2050  $\text{\AA}$  spectral passband. The lower half of the first order wavelength coverage (700-1025  $\text{\AA}$ ) also shows up in second order between the first order wavelengths of 1400 and 2050  $\text{\AA}$ .

Both the OAP and grating, and their mounting fixtures, are constructed from monolithic pieces of Al, coated with electroless Ni and polished using low-scatter polishing techniques. The OAP and grating optical surfaces are over coated with sputtered SiC. Control of internal stray light is achieved with a well-baffled optical cavity, and a holographic diffraction grating that has low scatter and near-zero line ghost problems.

For contamination control, heaters are mounted to the back surfaces of the OAP mirror and grating to prevent cold trapping of contaminants during flight. To protect the sensitive photocathodes and MCP surfaces from exposure to moisture and other harmful contaminants during ground operations, instrument integration, and the early stages of the mission, the detector tube body assembly is enclosed in a vacuum chamber with a front door that was successfully (and permanently) opened during the early commissioning phases of the flight. For additional protection of the optics and detector from particulate contamination during the flight, a front entrance aperture door is included that can close when the dust or gas levels are too high for safe operation and exposure (i.e., when the *Rosetta* Orbiter is close to the active comet nucleus), or the light levels are too high. The telescope baffle vanes also help to shield the OAP mirror from bombardment of small particles that enter the telescope entrance aperture.



### 3.1.4 Detector and Detector Electronics

The imaging photon-counting detector located in the spectrograph section utilizes an MCP Z-stack that feeds the DDL readout array. The input surface of the Z-stack is coated with opaque photocathodes of KBr (700-1200 Å) and CsI (1230-2050 Å). The detector tube body is a custom design made of a lightweight brazed alumina-Kovar structure that is welded to a housing that supports the DDL anode array (see Figure 3.1-2).

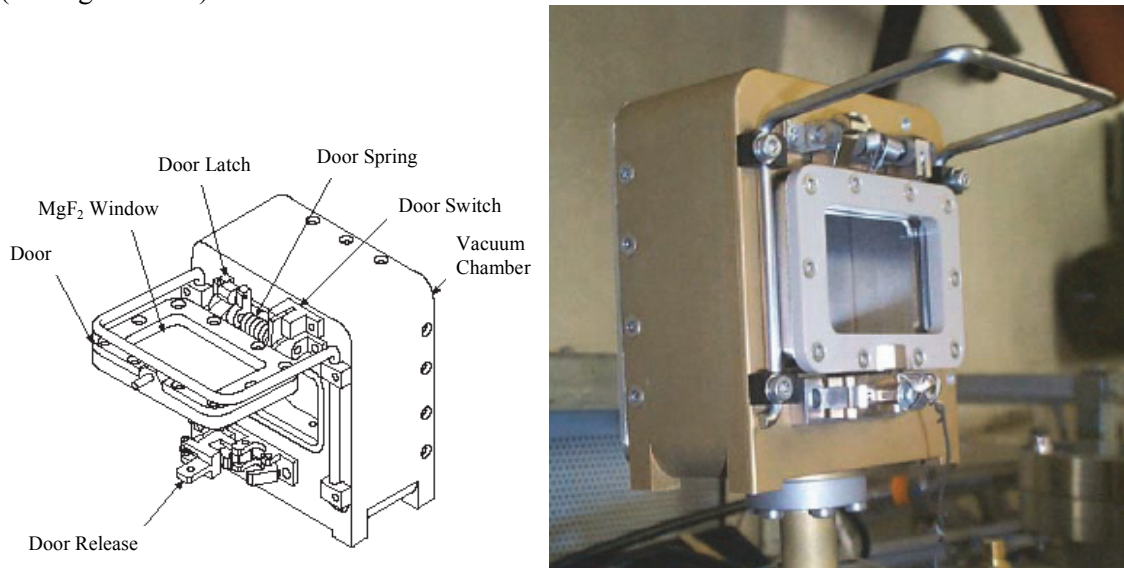

Figure 3.1-2. (Left) Schematic of the Alice DDL detector vacuum housing; (Right) Photograph of the PFM DDL detector vacuum housing.

To capture the entire 700-2050 Å passband and 6° spatial FOV, the size of the detector's active area is 35 mm (in the dispersion direction) x 20 mm (in the spatial dimension), with a pixel format of (1024 x 32)-pixels. The 6° slit-height is imaged onto the central 20 of the detector's 32 spatial channels; the remaining spatial channels are used for dark count monitoring. Our pixel format allows Nyquist sampling with a spectral resolution of ~3.4 Å, and a Nyquist-sampled spatial resolution of 0.6°.

The MCP Z-Stack is composed of three 80:1 length-to-diameter (L/D) MCPs that are all cylindrically curved with a radius-of-curvature of 75 mm to match the Rowland-circle for optimum focus across the full spectral passband. The total Z-Stack resistance at room temperature is ~500 MΩ. The MCPs are rectangular in format (46 x 30 mm<sup>2</sup>), with 12-μm diameter pores on 15-μm centers. Above the MCP Z-Stack is a repeller grid that is biased ~1000 volts more negative than the top of the MCP Z-Stack. This repeller grid reflects electrons liberated in the interstitial regions of the MCP back down to the MCP input surface to enhance the detective quantum efficiency of the detector.

The expected H I Lyman-α (1216 Å) emission brightness from comet 67P/CG is ~4 kR at a heliocentric distance of 1.3 AU (based on *IUE* observations of this comet in 1982). To prevent saturation of the detector electronics, it is necessary to attenuate the Lyman-α emission brightness to an acceptable count rate level well below the maximum count rate capability of the electronics (i.e., below 10<sup>4</sup> c s<sup>-1</sup>). An attenuation factor of at least an order of magnitude is required to achieve this lower count rate. This was easily achieved by physically masking the MCP active area where the H I Lyman-α emission comes to a focus during the photocathode deposition process. The bare MCP glass has a quantum efficiency about 10 times less than that of KBr at 1216 Å.

Surrounding the detector tube body is the vacuum chamber housing made of aluminum and stainless steel. As mentioned above, this vacuum chamber protected the KBr and CsI photocathodes against damage from moisture exposure during ground handling and from outgassing constituents during the early stages of the flight. It also allowed the detector to remain under vacuum ( $< 10^{-5}$  Torr) during ground operations, testing and handling, and transportation. Light enters the detector vacuum chamber through an openable door, which contains a built-in  $\text{MgF}_2$  window port that transmits UV light at wavelengths  $> 1200 \text{ \AA}$ . This window allowed testing of the detector with the door closed, and provided redundancy during flight if the door mechanism had failed to open.

The detector vacuum chamber door was opened using a torsion spring released by a dual-redundant pyrotechnic actuator (dimple motor). During instrument integration and test (I&T), the door was successfully opened numerous times and manually reset. In flight, the detector was successfully opened; however, the primary side of the actuator did not open the door—the redundant side was required to successfully open the door.

The detector electronics include preamplifier circuitry, time to digital converter circuitry (TDC), and pulse-pair analyzer (charge analysis) circuitry (PPA). All of these electronics are packaged into three  $64 \times 76 \text{ mm}^2$  boards. These three boards are mounted inside a separate enclosed magnesium housing that mounts to the rear of the spectrograph section (just behind the detector vacuum chamber). The detector electronics require  $\pm 5 \text{ VDC}$ , and draw  $\sim 1.1 \text{ W}$ .

The detector electronics amplify and convert the detected output pulses from the MCP Z-Stack to pixel address locations. Only those analog pulses output from the MCP that have amplitudes above a set threshold level are processed and converted to pixel address locations. For each detected and processed event, a 10-bit  $x$  address and a 5-bit  $y$  address are generated by the detector electronics and sent to the *Alice* command-and-data handling (C&DH) electronics for data storage and manipulation. In addition to the pixel address words, the detector electronics also digitizes the analog amplitude of each detected event output by the preamplifiers and sends this data to the C&DH electronics. Histogramming this “pulse-height” data creates a pulse-height distribution function that is used to monitor the health and status of the detector during operation. A built-in “stim-pulser” is also included in the electronics that simulates photon events in two pixel locations on the array (the rightmost [highest X-value] stim falls partially off the edge of the detector). This pulser can be turned on and off by command and allows testing of the entire *Alice* detector and C&DH electronic signal path without having to power on the detector high-voltage power supply. In addition, the position of the stim pixels provides a wavelength fiducial that can shift with operating temperature ( $\sim 0.5 \text{ pixel/degC}$  towards shorter wavelengths; in flight, the right-most stim on the short wavelength side of the detector is typically shifted off the array due to the thermal environment of the detector electronics).

### 3.1.5 Electrical Design

The instrument support electronics (see Figure 3.1-3) on *Alice* include the power controller electronics (PCE), the C&DH electronics, the telemetry/command interface electronics, the decontamination heater system, and the detector high-voltage power supply (HVPS). All of these systems are controlled by a rad-hardened SA 3865 microprocessor, supplied by Sandia Associates, with 32 KB of local program RAM and 64 KB of acquisition RAM, along with 32 KB of program ROM and 128 KB of EEPROM. All of the instrument support electronics are contained on 5 boards mounted just behind the detector electronics (see Figure 1.3-1 and Figure 1.3-3).



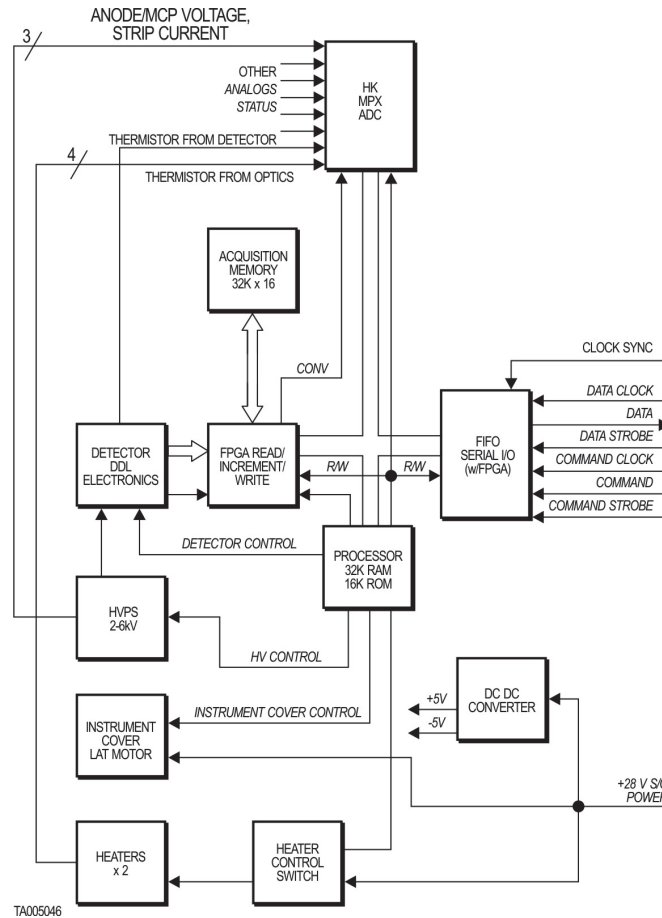

Figure 3.1-3. The Alice electrical block diagram.

**Power Controller Electronics.** The PCE are composed of DC/DC converters designed to convert the spacecraft power to  $\pm 5$  V DC required by the detector electronics, the C&DH and TM interface electronics, and the detector HVPS. Also located in the PCE is the switching circuit for the heaters and the limited angle torque (LAT) motor controller that operates the front aperture door.

**Command-and-Data Handling Electronics.** The C&DH electronics handles the following instrument functions: (i) the interpretation and execution of commands to the instrument, (ii) detector acquisition control including the histogramming of raw detector event data, (iii) telemetry formatting of both science and housekeeping data, (iv) control of the detector HVPS, (v) the detector vacuum cover release mechanism, (vi) the front aperture door control, (vii) the control of the housekeeping analog-to-digital converters (ADCs) which are used to convert analog housekeeping data to digital data for inclusion into the TM data stream, and (viii) on-board data handling.

**Telemetry/Command Interface Electronics.** The C&DH utilizes radiation tolerant buffers and FIFO memory elements in the construction of the spacecraft telemetry and command interfaces. A finite state machine programmed into a radiation hardened Actel 1280 FPGA controls the receipt and transmission of data. A bit-serial interface is used.

**Decontamination Heater System.** A single decontamination heater each ( $\sim 1$  W resistive heater) is bonded to the backside surface of both the OAP mirror substrate and the grating substrate. Along with each heater, two redundant thermistors are also mounted to the back of each substrate to monitor and provide control feedback to the heaters. The C&DH electronics can separately control each heater. Successful heater activations have already taken place during the commissioning phase of the flight. Additional activations are planned periodically during the long cruise phase to comet 67P/CG.

*High Voltage Power Supply.* The HVPS is located in a separate enclosed bay behind the OAP mirror (see Figure 1). It provides the  $-4.0$  kV required to operate the detector. The voltage to the Z-stack is fully programmable by command in  $\sim 25$  V steps between  $-1.7$  and  $-6.1$  kV. The mass of the supply is  $\sim 120$  g, and consumes a maximum of  $0.65$  W during detector operation.

### 3.1.6 Data Collection Modes

*Alice* can be commanded to operate in one of three data collection modes: i) image histogram, ii) pixel list, and iii) count rate modes. Each of these modes uses the same 32k word (16 bit) acquisition memory. The first two acquisition modes use the same event data received from the detector electronics but the data is processed in a different way. Also, in these two modes, events occurring in up to eight specific areas (each area is composed of 128 spectral pixels by 4 spatial pixels, that can only be positioned at a multiple of its size) on the array can be excluded to isolate high count rate areas that would otherwise fill up the array. The third acquisition mode only uses the number of events received in a given period of time; no spectral or spatial information is used and hot pixel masking will not affect the acquired data.

*Image Histogram Mode.* In this mode, acquisition memory is used as a two dimensional array with a size corresponding to the spectral and spatial dimensions of the detector array. The image histogram mode is the prime *Alice* data collection mode (and the one most often used during flight). During an acquisition, event data from the detector electronics representing  $(x,y)$ -pixel coordinates are passed to the histogram memory in parallel form. The parallel data stream of  $x$  and  $y$  values is used as an address for a 16 bit cell in the  $1024 \times 32$  element histogram memory, and a read-increment-write operation on the cell contents is performed for each event. During a given integration time, events are accumulated one at a time into their respective histogram array locations creating a two-dimensional image. The read-increment-write operation saturates at the maximum count of 65,535 so no wrap around can occur in the acquired data. The time information of the individual events within the acquisition is lost in this process, but, using appropriate acquisition durations, high signal-to-noise ratio data may be acquired even from dim objects. At the conclusion of the integration period the acquired data can be down linked in telemetry. In order to limit the required telemetry bandwidth, the histogram memory can be manipulated to extract only data from up to eight separate, two-dimensional windows in the array for downlink, and within these windows, rows and columns may be co-added to further reduce the number of samples.

*Pixel List Mode.* In this mode, the acquisition memory is used as a one-dimensional linear array of 32,768 entries. The pixel list mode allows for the sequential collection of each  $(x,y)$ -event address into the linear pixel list memory array. Periodically, at programmable rates not exceeding 256 Hz, a time marker is inserted into the array to allow for “time-binning” of events. This mode can be used to either (a) lower the downlink bandwidth for data collection integrations with very low counting rates, or (b) for fast time-resolved acquisitions using relatively bright targets in the *Alice* FOV. At the conclusion of this acquisition period the total amount of generated data can be further reduced by selecting only events that have occurred within up to eight separate windows for downlink.

*Count Rate Mode.* In this mode, the acquisition memory is again used as a one-dimensional linear array of 32,768 entries. The count rate mode is designed to periodically (configurable between 3 ms and 12 s) collect the total detector array count rate sequentially in the linear memory array, as if the entire instrument were an FUV photometer. This mode allows for high count rates from the detector (up to 10 kHz), without rapid fill up of the array. It does not, however, retain any spatial or spectral information for broadband photometric studies. Depending on the required periodic acquisition rate, total acquisition durations of up to 98 seconds to 100 hours are possible.

### 3.1.7 Detector Acquisition Durations

The actual start and end time of any acquisition is reported in the header of the science data dump, both specified in instrument (spacecraft) MET. The *Alice* post-processing chain (i.e. *Lima*, *Mike* and *November*) includes this information in the produced FITS files and calculates the acquisition duration from these numbers as the difference between the start and stop times. For histogram and pixel list acquisitions this calculated number represents the best available knowledge on the actual duration of the acquisition.

The acquisition duration is not always exactly the same as the commanded acquisition time. This is easy to understand for special cases where an acquisition was terminated early either by user command or because a safety condition occurred, but also for the nominal acquisitions there will be a difference between commanded and actual acquisition time. The reason for this is that the instrument software controls the acquisition hardware in such a way that also adds a kind of granularity to the acquisition duration, which is dependant on the specific acquisition mode. For the four different cases the consequences of this quantization will be discussed.

These timing measurements apply to each of the separate acquisitions within a MAD commanded (multi) acquisition sequence. The start time of an acquisition within a MAD multi acquisition sequence with a fixed cycle duration is checked every 0.5 seconds. This means that the start of an exposure within a multiple acquire cycle may occur up to 0.5 seconds later than expected from the commanded cycle duration. This start time error is not cumulative though; the start times of the multiple exposures are all related to the initial acquisition command start time.

#### 3.1.7.1 Histogram Acquisition

During a histogram acquisition, in parallel to the histogram acquisition a coarse count rate data set of up to 100 elements is acquired. This count rate data is included in the header of the data dump and the *Alice* post-processing chain places this data in the second extension of the generated FITS file. The minimum time resolution for this count rate acquisition is 100 ms for acquisition durations less than 10 seconds and the maximum is 25.5 seconds for acquisitions of 2550 seconds or more. For shorter acquisitions, the 100-element count rate buffer is only partially filled and for acquisitions longer than 2550 seconds (42.5 minutes) only the initial part of the acquisition is covered in the count rate measurements. This count rate measurement interval also determines the granularity of the histogram acquisition end time check. This means that for short histogram acquisitions the commanded end time is checked every 100 ms but for longer acquisitions the check is performed less frequently. The worst case situation occurs for acquisitions longer than 2550 seconds for which the termination condition is only checked once every 25.5 seconds, this means that worst case such an acquisition could continue up to 25.5 seconds longer than commanded. Except for the very short acquisitions (less than 10 seconds), where the acquisition duration may last up to 100 ms longer than planned, the maximum acquisition extension is always less than 0.4% of the commanded acquisition duration. In all cases the reported start and end times are the best available for the start and end of the actual acquisition (i.e. histogramming) operation.

As an example, a histogram acquisition commanded for 1000 seconds may last up to 10 seconds longer, and during that reported time the actual acquisition will have been active. The variation between individual 1000-second histogram acquisitions will probably be less as the check periods are based on a fixed check interval that is started at the beginning of the acquisition, but this is also determined by other tasks execution times within the software.

### 3.1.7.2 Pixel List Acquisition

For a pixel list acquisition the completion condition (end time or number of counts) is checked every second. For a time limited pixel list acquisition, this means that the duration of the acquisition can be up to one second longer than commanded, and additional events (hacks and real events) will be captured during this period. For a count limited pixel list acquisition, this means that for one second after reaching the commanded event count (hacks and real events) more events may be accumulated. In any case the acquisition will always terminate when the end of the acquisition buffer is reached, but also in that case the recorded end time may be up to 1 second after the actual event (0.2 seconds after the event for software version 2.05).

A more accurate estimate of the end acquisition time (and the acquisition duration) can be determined by using the time hacks embedded in the acquired pixel list. In that case the accuracy of the acquisition end time is determined by the selected hack rate (note that this method is not used in the current Lima program).

### 3.1.7.3 Count Rate Acquisition

For a count rate acquisition the number of counts per sample slot is specified. Exactly this number of slots will be acquired, unless the end of the acquisition buffer is reached first. The check for the end of the acquisition is performed once every second, so the actual reported acquisition end time may be up to one second after the actual acquisition completion (although different from the pixel list acquisition no additional data will be stored). The acquisition duration and a more accurate estimate of the end time can also be determined by calculating the duration from the number of acquired slots and the interval (note that this method is not used in the current Lima program).

## 3.1.8 Analog versus Digital Detector Count Rates and Rate Doubling

The *Alice* instrument detector includes two separate data paths through which the events are reported. The primary path is the digital event interface through which the C&DH receives the detected photon event (spectral location, spatial location and pulse amplitude) as a 19 bit digital word. For monitoring purposes, a second path is used that only reports the fact that a photon is detected by the detector; this is the raw (analog) event. The second path may report a higher number of events when the processing of the digital data cannot keep up with the photon events, but this only comes into effect for extremely high count rates (>100 kHz). The first path is used by the C&DH to acquire the data for both histogram and pixel list acquisition modes, and depending on the selected acquisition mode the acquisition hardware stores data in the acquisition buffer. The second path is used by the C&DH to count the instantaneous count rate (the number of photons detected per unit of time). This data is used for the instrument safety checking, is reported in housekeeping data and is used by the software in the count rate acquisition mode. The first two uses determine a per-second count rate, and the count rate acquisition determines the count rate based on the time period specified for the count rate acquisition (3 ms - 11.9 s).

The detector electronics includes a feature in which the generation of the digital event data stream (activated on both histogram and pixel list hardware acquisition modes) influences the detector level of the raw analog events. Roughly, the activation of the digital interface will result in a doubling of the number of events reported on the raw analog interface due to a switching bounce. This undesired behavior was found too late in the instrument development to be corrected. The resulting effect of this feature is that ***whenever a histogram or pixel list acquisition is active, the reported analog count rate, which is based on the raw (analog) event rate, is about double the actual rate. Since this count rate is internally used for the safety checking, the safety limit has to be increased in order to prevent triggering the instrument safing.*** Note that this doubling does not occur in the count rate acquisition mode, since the count rate acquisition is a completely software controlled acquisition mode that does not use the digital event interface.

### 3.1.9 Code Memory Management

The *Alice* instrument has different code memory spaces. After power-up *Alice* will start executing code from PROM memory. The code is directly executed from PROM (in the C&DH architecture there are no drawbacks to executing from PROM and the big advantage is that the code cannot accidentally overwrite itself). The C&DH also provides four separate EEPROM pages from which the processor may execute code. At launch these pages contained the same code images as the PROM so these were just redundant code images. (All EEPROM pages have been patched with new versions of the code since launch.) By telecommand, *Alice* may be instructed to start executing code from one of the four EEPROM pages. This redundant storage is initially used to provide an additional safeguard; during the software startup the PROM code is verified using a checksum embedded in the PROM code. If the checksum fails, the code is assumed damaged, and *Alice* starts testing the four EEPROM pages. If, on any of those pages, code with a valid checksum (stored again with the code then in the EEPROM memory) is found, that page will start execution. The main use of the EEPROM memory, however, is to be able to perform code patches. Using telecommands (memory load) new code may be uploaded and installed in the instrument to correct certain defects that have been found or to implement improved/changed operational code. Once uploaded this code becomes available for execution and by means of a telecommand *Alice* can be instructed to start executing this new code. Note that after power up the instrument still starts executing the code in PROM and that this code is used to make the jump to the newly loaded code.

The *Alice* C&DH also contains general-purpose data storage memory (RAM). About 50% of this memory is used during normal system operations to store variables and to create some data buffers. Using telecommands executable code could also be uploaded into this RAM memory and even be executed directly in RAM (using again the same telecommand mechanism). This execution may be useful in two specific cases: 1) when a test or diagnostic function is needed once it may just be uploaded in RAM and executed there (once the test is completed and the instrument is switched off the memory contents will be lost); and 2) to possibly store code patches that are needed for instrument operation when the EEPROM is not available because of a failure. The disadvantage of these patches would be that these have to be reloaded each time after a power cycle.

[Note: The lifetime of the EEPROM memory is (after derating) limited to 1000 write cycles (when used in block write mode, as in *Alice*). To ensure that the maximum number of cycles is not exceeded a manual administration of the number of used (write) cycles (per page) will be maintained. In addition to the limited lifetime, the EEPROM memory will also gradually lose charge and thus eventually will lose memory contents. To prevent loss of the stored information the memory should be updated or refreshed at least once every 5 years, as stated in Flight Rule EMP.3.]

#### 3.1.10 Software Code Patch Operation

The *Alice* instrument provides four pages of EEPROM memory that can be used to store updated versions of the instrument flight software. The instrument always starts up from code in PROM (unless a problem is discovered in this code by the startup code; see Section 3.1.9.). After this point the instrument can be commanded to start executing code in one of the four EEPROM pages. When the instrument is launched aboard the *Rosetta* spacecraft, these four pages contain simple copies of the *Alice* flight software stored in PROM (this version of the *Alice* flight software is documented in the '*Alice* Flight Software Version 2.04', 8225-AFS\_REL-01, Revision 4 Change 0, dated 10/18/2004).

When executing code in PROM, the contents of the EEPROM memory can be modified using the LoadMemory telecommand. In each separate command up to 128 bytes of data can be loaded. When the need for changes in the operation of the flight software is discovered a new flight software version will be produced. This will consist of a new 32 kbyte code image. After test and verification such a new software release will be documented in a new release of the Flight Software Document. Another need for a code memory patch could be failure of certain locations of the RAM memory. The RAM memory map is fixed

in the flight software but a new memory map could be used to create a new version of the flight software that avoids using the affected locations.

Depending on the changes, different strategies may be followed to upload such new code into one of the EEPROM memory pages of the instrument. If the number of changes is limited, only the changes from the version of the software in the target EEPROM page may be loaded; otherwise, a complete 32 kbyte code upload package will have to be produced. The full 32 kbyte code upload would result in a total of 256 memory load telecommands.

Initially, code changes would be made to the last page (EEPROM 3) of the EEPROM memory, keeping the first three pages as backup of the current version of the flight code (if the startup check algorithm detects a problem, it will successively check the EEPROM pages for correct code starting at the first page, so the patched page will be the last one to be checked if the others are damaged; this way, patched code is less likely to be prematurely run). If only a one-time patch is needed to the code (e.g. to execute a specific test or perform a one-time operation), the code need not be loaded in EEPROM at all. The current system uses less than 50% of the available RAM space and code can also be executed from this RAM memory.

### 3.1.11 In-Flight Aperture Door Performance Tests

The aperture door in the *Alice* instrument is a limited life item, and proper operations are critical for successful instrument operations. The design lifetime for the aperture door is 10,000 door cycles. During instrument testing an extensive verification tested the door for 20,000 operations, but in the original version 2.03 of the flight software (which still resides in PROM) there was no means to determine the operations of the door in the flight instrument. The *Alice* Flight Software version 2.04 was extended with a door performance measurement (a minor buffer overrun bug was corrected in version 2.05). This measurement function performs a precise measurement of the door operation using the two optical switches on the door to determine the door open and door close position event times during a door operation. The measurement function is a special function, which, in order to reach the 33 ms resolution, has to temporarily suspend normal software operations. For each door movement two time measurements are performed: the first one determines how much time it takes for the door to start moving (clears the door closed switch), and the second measurement determines how much time it takes to reach the end position (reaches the door open switch). The same measurements are performed during the following door close move, resulting in four measurements per door cycle. The results of these measurements are stored in a special buffer that is located at a fixed location in the processor RAM area (starting at [word] address 0x5b00). This buffer is used as a circular storage and can hold up to 64 one-word time values (size is 128 bytes). Each door measurement results in 4 measurement cycles so the buffer can store up to 16 complete measurements. To retrieve the data from the buffer, the standard available memory dump command has to be used.

This aperture door performance test is performed with the *Alice* command sequence AALS404A. That sequence first restarts *Alice* in a user-defined EEPROM page then calls the subroutine by executing the address where the code resides sixteen times. A typical test consists of 30 to 40 “flaps” (i.e., two calls to AASL404A). Attachment 2 describes the latest results of the in-flight door performance tests.

As of September 2006, the *Alice* aperture door has cycled open-close 639 times.

### 3.1.12 Fail-Safe Door Activation

If the front aperture door fails to open during any phase of the flight, a one-time openable fail-safe door can be activated that allows ~5% of the airglow aperture throughput into the instrument. The fail-safe door is held in the closed state via a latch pin that retains the door closed against the aperture stop baffle at the bottom of the stop. The door is activated to open when the latch pin is retracted via the firing of a dimple motor (via command to the spacecraft interface to the dimple motor). The spring attached to

the door is then free to pull the door into the open position. In the open position, the fail-safe door lies flush against the bottom floor of the instrument housing.

Opening the fail-safe door is a critical command. The peak current draw during the fail-safe door opening is 4 Amps over a 10 millisecond period.

## 3.2 Operating Modes

### 3.2.1 Ground Test Plan (from *Alice* EID-B, § 5)

The *Alice* PFM requires very little by way of ground operations facilities or personnel. With its flight detector sealed internally and the detector vacuum verified by the ion pump current, the instrument is safe to operate at one atmosphere. Cleanliness precautions do need to be taken to prevent contamination of the optics. A dry nitrogen purge must be maintained on the instrument when it is not stored in its shipping container.

After integrating *Alice* to the spacecraft, the following tests shall be performed:

- Optical alignment
- Pre-environmental Functional Tests
- End-to-end Command and Data Handling Tests (uplink commands/TM interface checks--downlink of HK data channels)
- Decontamination heater checkout
- Dimple motor firing test (per procedure 8225-DIMP-01)
- Detector dark count test (internal cover closed)
- Detector wavelength cal and focus check (using GSE Pt stim lamp at entrance aperture -- 1800 to 2050 Å; interior of instrument under GN<sub>2</sub> purge)
- Microprocessor software checkout with flight-like sequence
- Environmental Tests (after each test below, a limited electrical functional test is performed)
- EMI/EMC tests
- Random vibration tests
- Acoustic vibration tests
- Thermal vacuum tests
- Post-environmental Functional Tests (same as the pre-environmental functional tests listed above)
- Final optical alignment check

*Alice* can be fully verified and tested on the bench, and on the *Rosetta* spacecraft. This is possible because the detector can be pumped down to a safe operational vacuum level ( $< 8 \times 10^{-6}$  Torr) using the GSE vacuum pump cart and GSE vac-ion pump hardware. Full functionality and optical alignment can be verified without opening either the detector or front aperture doors. The detector door is equipped with a MgF<sub>2</sub> window that transmits UV light at wavelengths  $>1200$  Å; the front aperture door is equipped with a removable plug in its center that can be taken out during ground test to allow light to enter the instrument. This removable plug is a flight item; it will be installed for flight (a “green-tag” attach-before-flight item). The detector door is a one-time operation in flight. It will never be opened during S/C ground integration and test activities.

During bench level functional testing, *Alice* will be stimulated with a UV-emitting platinum-neon (Pt-Ne) hollow-cathode lamp that emits UV light at wavelengths  $>1200$  Å. This lamp will be mounted in close proximity to the MgF<sub>2</sub> window port on *Alice*'s internal front aperture cover. Wavelengths down to

the MgF<sub>2</sub> window cutoff (~1200 Å) will transmit through the instrument as long as the instrument is filled with GN<sub>2</sub>. The length of this Pt-Ne stim lamp will not exceed ~30 cm.

With the detector vacuum cover closed and the internal detector tube body pressure < 8 x 10<sup>-6</sup> Torr, it is safe to operate the detector at the full operational high voltage level (~4 KV). The UV emission lines from the Pt-Ne lamp will stimulate the detector across a portion of its active area.

During spacecraft level integration, the *Alice* instrument can be turned on and tested end-to-end at any time the GSE ion-pump is attached to the instrument and detector vacuum is verified (by noting the ion-pump current). Because of the logistics problem, no detector HV tests will be performed during spacecraft thermal vacuum (T/V) testing (because of the difficulty and cost of providing a UV source that can be operated in vacuum). The *Alice* detector will, however, be evacuated using the *Alice* MGSE vacuum pump station prior to the T/V test; following the test, the detector will be backfilled with GN<sub>2</sub>.

To keep the interior optics (grating and OAP primary mirror) clean and dry, *Alice* will require continuous purging with dry GN<sub>2</sub> while on the spacecraft at a low purge rate of ~2 L/hr. The purity of the GN<sub>2</sub> should correspond to MIL-P-27401C Grade C or better. Interruptions of gas flow during spacecraft handling or servicing operations should not exceed 5 hours. During spacecraft transport, the flow may be stopped for up to 168 hours although the interior of *Alice* must remain in a dry GN<sub>2</sub> environment during this time. Additional *Alice* purging requirement details can be found in the *Alice* Contamination Control Plan (SwRI 8225-CCP-01).

### 3.2.2 In-orbit Commissioning Plan

The *Alice* commissioning activities were split into three separate phases as shown in Table 3-1. Each Phase was composed of a set of related test sequences called activity groups. All the described sequences were stand-alone entities that did not depend on the state at the end of a previous sequence. Each sequence started with a power on of the *Alice* instrument, and at the end of the sequence, *Alice* was powered off.

Table 3-1. *Alice* Commissioning Phases

Commissioning objectives	Activity Groups	Notes
Phase I - Basic Safing	1 - 7	Must be performed early in the mission to place <i>Alice</i> in a safe condition for flight.
Phase II - Electrical Functionality	8 - 13	Preferably to be performed early in the mission to obtain knowledge of <i>Alice</i> instrument health.
Phase III - Scientific Functionality	14 - 20	Can be performed later in the mission but must occur prior to the Mars fly-by.

Phases I and II represent the sequences and commissioning steps that *Alice* performed (mostly) independent of the other *Rosetta* instruments. Phase I consisted of seven Activity Groups that were essential to bring *Alice* into a safe configuration, and which were used to prepare *Alice* for subsequent commissioning sequences. Phase II consisted of six activity groups that performed a basic electrical functional verification of the instrument. Phase III consisted of scientific calibration and verification of the optical alignment with the other *Rosetta* instruments.



### **Phase I (2004 March 22-23, April 15-20)**

The first three Activity Groups (1-3) verified basic communication functionality, unlatched the aperture door, and verified correct operation of the aperture door. Also, the ROSINA- and GIADA-based safety mechanisms were verified. Activity Groups 4 to 6 mainly consisted of optical decontamination sequences of the instrument; long periods were spent with the aperture door open and the mirror and grating heaters on to enable outgassing of the *Alice* instrument. The last Activity Group (7) in this Phase opened the detector door.

### **Phase II (2004 April 20-22, May 28-29)**

Phase II is started with three Activity Groups (8-10) dedicated to verification of the basic detector operations and a continuation of the instrument decontamination procedure. Activity Groups 11 and 12 concluded this initial phase of the *Alice* in-flight commissioning with a verification of the functionality of the various acquisition modes and operations, a decontamination sequence, and finally an end-to-end Performance Aliveness Test (PAT). This last test verified the basic end-to-end electrical functionality of the *Alice* instrument.

### **Phase III (2004 September 20-30, October 4)**

Phase III included a series of Activity Groups for scientific calibration and verification of the optical alignment between instruments on the *Rosetta* spacecraft. Phase III started with the interference test (Activity Group 14); defined by ESA to characterize possible interference between the different experiments on the *Rosetta* spacecraft. Following the interference test, two Activity Groups (15-16) were dedicated to the alignment measurements that determine the relative alignment of the different experiments on the spacecraft. For *Alice*, the alignment measurement determined the relative alignment of *Alice* with respect to OSIRIS, and possibly other instruments. For all alignment tests, it was mandatory that OSIRIS was also active, so the results of the *Alice* test could be compared with the science observations made by OSIRIS. The final four Activity Groups (17-20) were dedicated to *Alice* science calibration.

### **Commissioning Activity Descriptions**

Descriptions of various activities that occurred during the Commissioning phase are described below. They are written in the “future tense” as they were before commissioning began. The actual details of each flight commissioning activity can be found in *Rosetta-Alice* engineering memorandums.

Optics Decontamination. During the commissioning phase of the flight and during the instrument checkout phases prior to science target encounters, the *Alice* optics will require heating to drive off contaminants that have collected on their respective surfaces. Each optical element (i.e. the OAP mirror and grating) is equipped with a 1-Watt resistive heater. Each optic is also equipped with redundant thermistors. The *Alice* C&DH electronics will be responsible for control and monitoring of the decontamination heaters and thermistors. It should be noted that the *Alice* instrument will need to be in a near full power-up mode before turning on the decontamination heaters (i.e. C&DH electronics, detector electronics and HVPS will all be on except for the initial decontamination sessions prior to the opening of the detector door). This is necessary for 1) control and monitoring of the decontamination activity, and 2) to provide joule-heating to the detector MCP Z-stack to prevent constituents off-gassed from the optics from collecting on the sensitive detector surface. Note that in subsequent operations, the HV is not applied to the detector for decontaminations; it was decided that the joule heating was not significant, and running HV for long decontaminations was not necessary.

*Aperture Door Opening.* During the initial turn on and checkout of *Alice* (Commissioning Phase I) the *Alice* front aperture door will be opened. This activity will take place only after it has been determined from ROSINA pressure data that there is minimal outgassing from the surrounding spacecraft. With *Alice's* low-voltage power on, and the detector HVPS OFF, the command to open the front door will be executed. This procedure will include firing the aperture door dimple motors to un-cage the aperture door and powering the limited angle torque motor to open the door. Once the door has been opened, the instrument's internal surfaces will be allowed to outgas through the entrance aperture out into space for a period of time sufficient to fully out-gas the *Alice* instrument. This outgassing may be assisted by using the mirror and grating heaters to increase the temperature of these components. Following this period, the *Alice* detector door may be opened.

*Detector Vacuum Door Opening.* During the initial turn on and checkout of *Alice* (Commissioning Phase I) the detector vacuum door will be opened for the first and only time during the flight. With *Alice's* low-voltage power on, the instrument's front aperture door open, and the detector HVPS OFF, the command to open the vacuum cover will be executed. Once the cover has been opened, the detector's internal surfaces will be allowed to outgas into the surrounding spectrograph housing section, and out into space through the entrance slit, vent baffles, and telescope entrance aperture for a period of time sufficient to equilibrate with its surroundings. Following this equilibration period, high-voltage will be applied to the detector's MCP stack using a very slow high-voltage ramp up procedure. At the completion of the HV ramp-up, the detector will be operating at the full operational MCP voltage level. Image exposures of the dark sky will be taken along with detected event Pulse Height Distribution (PHD) data to ascertain the health and status of the detector and the optics.

*Aliveness/Functional Tests.* These tests consist of turning on the instrument, the gradual ramping up of the high-voltage to *Alice's* detector to the full operational high-voltage level, and brief integrations of the dark sky to observe H Lyman- $\alpha$  emission, observe two UV-calibration stars ( $\alpha$  and  $\gamma$  Gruis), and to collect pulse-height distribution (PHD) data of valid events recorded by the detector. These data will be used to ascertain the health and status of the detector and the optics. The first observations of the UV-bright stars will be made in count rate mode. Both stars will be observed by physically scanning (slewing the spacecraft) orthogonal to the length of *Alice's* entrance slit at a rate of 0.005 deg/sec for 1000 sec (binning at 0.096 second), providing a FOV of 5° x 6° nominally centered on the target. Two such scans (i.e., going back and forth) will be performed for each star. The second observations will be made in pixel list mode with a similar scanning motion, for 200 sec (time hack interval of 0.125 sec), providing a FOV of 2° x 6°, nominally centered on the target.

*Optical Alignment Check.* The purpose of this observation will be to determine the position of *Alice's* FOV with respect to the center of the wide angle camera's FOV. Alignment checks will be made during the Commissioning Phase (*Alice* Commissioning Phase III) and active checkouts, and will consist of count rate and pixel list scans (as described in Sections 2.2.7 and 3.1.6) and "jailbar" observations. A jailbar is a series of histogram images with pointing shifts (typically by a fixed amount) between each exposure. For the case of these alignment observations, the shifts are typically small (~0.01 deg) compared to the width of the narrow part of the *Alice* slit (0.05 deg) to provide overlapping images centered on a calibration. Each of these *Alice* histogram exposures will result in a 2D spectral image [(1024 x 32)-pixel format]. The spectral images taken in this sequence of observations will allow a determination of the boresight direction of *Alice's* FOV with respect to the known position of the star and relative to the NAVCAM camera, which will take images several jailbar points. The jailbar exposures will also provide a measurement of the slit throughput as a function of distance from the slit center.

### 3.2.3 Instrument Checkout and In-Flight Calibration

#### 3.2.3.1 In-Flight Checkouts

##### “Passive” Checkouts

These tests (originally referred to as 6-month instrument checks) are intended to allow instruments to perform periodic aliveness checks and functional tests that exercise mechanisms and conduct health checks that do not require specific pointing, and can be done with no real time monitoring or special planning. They run off the MTL with no parallel operations among different PI instruments, and produce minimal science data. Typically, a total of about 5 days are allotted for passive checkouts of all Rosetta instruments. The original plan for *Alice* 6-month checkouts (Commissioning Sequence 13.B) consisted of operating the aperture door through 12 open/close cycles, briefly operating the decontamination heaters for ~5 minutes to check that they are still active, and acquiring a pixel list exposure with the detector stims turned on to check the functionality of the detector electronics and C&DH electronics. High voltage operation of the detector is not planned for passive checkouts. However, after commissioning during the in-flight planning cycle for the first passive checkout, the *Alice* team decided to omit any “activation” operations (i.e., no HV, heaters) from all passive checkouts to minimize risks, and instead, include those operations and other extended testing and calibration activities in the roughly annual active checkouts.

The *Alice* passive checkout plan runs:

- A reduced power-up check [AALS104A]
- Checksums [AALS703A]
- Nine runs of the door performance test [AALS404A]
- Power off [AALS103A]

##### “Active” Checkouts

These tests will be more extensive than the passive checkouts, typically lasting a total of several weeks, providing more time for each instrument. They will allow for special pointing, higher Science data production, and more immediate data downlink and monitoring. The *Alice* active checkout plans will differ each time, but typically will likely include:

- A run of the standard Passive Checkout operations
- A full power-up check [AALS101A]
- A long decontamination running the optics heaters
- HV rampup [AALS302x]
- Multiple exposures at different voltages to check pulse-height distributions to determine best operating voltage.
- Three long (each 1 hour or longer) dark exposures [AALS531A]
- Deep background/sky exposures
- Calibration observations of at least two stars including:
  - Alignment scans across the three parts (upper wide, narrow middle, lower wide) of the slit in pixel list mode
  - “Jailbar” flux calibrations in the three parts of the slit in histogram mode
  - Pixel list exposure to measure jitter of the star in the slit
- Verification of Service 19 pressure and dust limit checks
- A long decontamination running only the optics heaters
- HV off [AALS303A]
- Close aperture door [AALS402A] after sufficient time for cooling
- Refresh all EEPROMS if necessary (see Flight Rule EMP.3)
- Power off [AALS103A]

### 3.2.3.2 In-Flight Calibration

In-flight calibration sequences using hot UV stars shall take place periodically during the mission (e.g. during the initial commissioning phase and during active checkouts) and before/after any observational campaign (e.g. Earth fly by, Mars flyby, etc.). The set of UV stars chosen shall have been observed and calibrated for flux versus wavelength within the *Alice* UV passband with IUE. The following shall be measured during these calibration runs:

- Effective area versus wavelength and spatial location along slit;
- Point spread function/focus;
- Wavelength calibration;
- Pointing;
- Detector dark count rate.
- MCP pulse height distribution

Trending of the above quantities shall also take place during the mission to identify and track changes in instrument performance. For best trending, the same set of UV stars shall be observed (when possible) during each in-flight calibration run.

### 3.2.4 Flight Operations Plans per Mission Phase

Mission phases are described in the Rosetta Mission calendar (document RO-ESC-TN-5026). *Alice* operations are not uniquely defined for each mission phase, since each phase will have many similar components (calibrations, pointed or scanning observations, etc.), and depend on the details such as flyby geometry, constraints that may be imposed by the spacecraft or other instruments, and the status of *Alice*. Below we provide general outlines of the high-level operations that at this time are expected to be used in each type of mission phase.

Most operations will typically include power-up tests, decontaminations, calibrations, and observations in any or all of the *Alice* acquisition modes.

#### 3.2.4.1 Commissioning

Commissioning includes instrument validation and testing, calibration (alignment, sensitivity, wavelength), interference tests, initial testing of operational procedures of the *Alice* instrument and of the interfaces (instrument to spacecraft, spacecraft to ground, DDS to PI institution, PI to RSOC). See Section 3.2.2 for sequences and operations used uniquely for the commissioning phases during the first year after launch. Many of the sequences therein have been subsequently removed from the FOP since they are no longer applicable after completion of commissioning.

#### 3.2.4.2 Cruise

The several cruise phases will typically include passive and active Payload Checkouts (PCs), which are described in Section 3.2.3.1. Note that passive checkouts originally were referred to as “6-month checkouts”, but the timing and nomenclature changed.

#### 3.2.4.3 Earth Swing-by

There are three Earth Swing-bys: March 2005, November 2007, and November 2009.

Earth Swing-by observations provide the only opportunity for particular in-flight calibrations of the *Alice* instrument. The Moon is the only object that can provide: (i) a large, bright, and uniformly illuminated source for a filled-slit flat field, (ii) an absolute solar flux calibration, particularly for the short wavelength ( $< 912\text{\AA}$ ) regime of the *Alice* passband, and (iii) an extended object scattered light evaluation. Operations will include exposures in all acquisition modes using both fixed and scanning pointing.

#### 3.2.4.4 Mars Swing-by

There is one Mars Swing-by: February 2007.

*Alice* will produce the first Mars EUV dataset ever obtained at Mars and the highest-ever EUV spatial resolution. Operations will include dayglow, nightglow, and auroral observations, stellar occultation observations to study the Martian atmosphere. The Rosetta Mars Swing-by will coincide with the New Horizons flyby of Jupiter, so *Alice* can also observe Jupiter during this phase to provide large-scale data in support of Jovian magnetotail, aurora, and Io Plasma Torus studies. Operations will include exposures in histogram and pixel list modes using both fixed and scanning pointing.

#### 3.2.4.5 Asteroid Flybys

Detailed operations are still to be determined, but as with other phases, will include exposures in histogram and pixel list modes using both fixed and scanning pointing. The primary objective will be surface reflectance studies.

#### 3.2.4.6 Comet Rendezvous, Mapping, and Escort

During these comet phases, standard science observations with *Alice* will occur. During these observations, exposures that vary from a few seconds to much longer (for deep spectral imaging) will be taken, depending on the minimum desired radiance level to be detected. Both imaging and non imaging observations are planned. During the imaging runs, *Alice* will be slowly scanned in the direction orthogonal to the length of the entrance slit to allow the build up of a 2 D image across a swath 6 degrees in length by the scan distance, and with an angular resolution (Nyquist sampled) of  $1.7 \times 10.0 \text{ mrad}^2$ . Both (1024 x 32) pixel and (512 x 8) pixel images will be taken depending on what specifically is being observed. During the non imaging runs, *Alice* shall observe a region on the target object for a period of time necessary to achieve the desired SNR for a chosen minimum radiance level. After the (1024 x 32) pixel image is through accumulating, the image may be collapsed spatially to a one-dimensional spectrum [1x1024 pixels], and stored for eventual transmission to the spacecraft data system.

#### 3.2.4.7 Targets of Opportunity

Targets of Opportunity (e.g., a nearby comet, or coordination with another mission such as *Deep Impact* [comet Tempel 1] and *New Horizons* [Jupiter]) may arise during any phase of the mission, and operations for these events will be uniquely defined by the target, viewing conditions, etc.. If *Alice* participates in the observations of such targets, operations again will typically include the standard suite of operations.

Similarly, during any flyby or comet phase, stellar occultations may take place that we would want to observe with *Alice*. With the target star in the *Alice* slit during the occultation period, observations will typically be made in pixel list mode to provide time resolution during occultations. Additional calibration observations will be made of the target star long before or after the occultation event to provide a “clean” spectrum for comparative analysis; these spectra will typically be made with long histogram mode exposures to obtain high S/N.

### 3.2.5 Interferences

There are no known interferences (other than those listed in the Flight Operational Constraints—Section 3.2.6) that limit the performance of *Alice* on the *Rosetta* spacecraft. During initial interference tests performed in September 2004, no interferences were seen in *Alice* data due to other instruments, and none due to *Alice* were reported by other instruments. However, those interference tests were not fully inclusive of all instruments and modes, so more interference tests are still planned by ESA for sometime after 2006, possibly much later.

### 3.2.6 Operational Constraints (Flight Rules)

The *Alice* flight operational constraints (a.k.a. the “Flight Rules”) are presented below (this is version 2.2, dated 14 April 2005).

#### **01. BRIGHT OBJECT AVOIDANCE (BRT)**

##### **BRT.1 Thermal Protection**

- (i) In order to prevent thermal damage, *Alice* will never be pointed within 11 deg of the Sun with either the aperture door or the fail-safe door open.
- (ii) The front aperture or the fail-safe door can be pointed at the Sun indefinitely, even at 1 AU when the aperture door and fail-safe door are closed.

##### **BRT.2 Excessive Count Rates**

In order to prevent excessive count rate backgrounds, whenever HVPS is ON, *Alice* will never be pointed

- (i) within <20 deg of the Sun with the aperture door open, or
- (ii) within <10 deg of the Sun with the fail-safe door open.

##### **BRT.3 Excessive Count Rates**

- (i) Unless otherwise stated by the *Alice* team, in order to prevent excessive count rate backgrounds, when HV>2500 V, and with the aperture door or fail safe door open, no portion of the *Alice* slit shall ever be pointed within  $\pm 0.5$  deg of any source in the *Alice* Bright Star Avoidance List (Attachment 1 in this document).

#### **02. INITIAL START UP (INIT)**

##### **INIT.1 Thermal Protection**

- (i) The temperature reference point temperature shall be between  $-20 < T < +50$  C.

#### **03. HV OPERATIONS (HV)**

##### **† HV.1 Initial Turn-On Requirements**

- (i) At least 30 days shall have elapsed since launch.
- (ii) ROSINA shall measure a spacecraft pressure  $< 10^{-5}$  millibars ( $7.5 \times 10^{-6}$  Torr).
- (iii) The aperture door shall be open. (Note: If the aperture door is failed closed, a failsafe door open turn on may be considered.)
- (iv) >24 hours of decontamination heating of the OAP and grating shall have been performed.
- (v) *Alice* shall be pointed to a safe attitude;
- (vi) *Alice* shall have all 8 measured temperatures within their nominal operating range and acceptable to the Project Manager.
- (vii) HV turn on shall be a critical command (i.e., must be followed by a “confirm critical” command).
- (viii) Initial turn on shall require a real time (light delayed) link and a slow HV ramp up.

### **HV.2 General Turn-On Requirements**

- (i) ROSINA shall measure a spacecraft pressure  $<10^{-5}$  millibars ( $< 7.5 \times 10^{-6}$  Torr).
- (ii) All instrument-read thermistors must be within the range from  $-35$  to  $+60$  C.
- (iii) If either the Aperture Door or Fail-safe Door is open, *Alice* shall be pointed in a safe direction.
- (iv) HV turn on shall be a critical command (i.e., must be followed by a “confirm critical” command).

### **HV.3 Shutdown conditions**

- (i) ROSINA pressure above  $10^{-5}$  millibars.
- (ii) GIADA dust alert  $>30$  counts/m<sup>2</sup>/min.

### **HV.4 S/C slew operations**

Unless otherwise stated by the *Alice* team (e.g., except for slews designed for *Alice* science operations), during S/C slew operations,

- (i) the *Alice* HVPS shall be powered to a non-sensitive level ( $\leq 2500$  volts) or off (to an MCP output voltage of 0 volts), and/or
- (ii) the aperture door shall be closed

### **HV.5 S/C thruster firings**

- (i) The *Alice* HVPS shall be powered off (to an MCP output voltage of 0 volts) during any Rosetta spacecraft thruster firings and shall remain off for at least 30 minutes after end of thruster firings.

## **04. LAUNCH LATCH OPERATION (LATCH)**

### **† LATCH.1 Opening**

- (i) *Alice* shall be in a safe attitude.
- (ii) HV shall be off.
- (iii) *Alice* shall have all measured temperatures within their nominal operating range, i.e.,  $-20 < T < +50$  C at the temperature reference point.

## **05. APERTURE DOOR OPERATIONS (AD)**

### **AD.1 Opening**

- (i) The Aperture Door open command shall be a critical command.
- (ii) *Alice* shall be in a safe attitude.
- (iii) *Alice* shall have all predicted temperatures within their nominal operating range, i.e.,  $-20 < T < +50$  C at the temperature reference point.

### **AD.2 Maintenance**

- (i) The LAT motor of the aperture door shall be cycled a minimum of 20 times (10 cycles) per flight year.

### **AD.3 Total Cycles**

- (i) The planned number of door cycles after launch will not exceed 10,000 (for a safety factor of 2). Door cycles must be rationed accordingly.

### **AD.4 S/C thruster firings**

- (i) Unless otherwise stated by the *Alice* team, the aperture door shall be closed during planned Rosetta spacecraft thruster firings and shall remain closed for at least 30 minutes after end of thruster firings.

## **06. DETECTOR DOOR OPERATION (DD)**

### **† DD.1 First DD Opening**

- (i) *Alice* shall have all measured temperatures within their nominal operating range, i.e.,  $-20 < T < +50$  C at the temperature reference point.
- (ii) Real time contact is strongly desired.
- (iii) HV shall be off.
- (iv) The aperture door or fail-safe door shall be open.
- (v) Both the mirror and grating heaters shall be turned on.
- (vi) Detector door opening shall not be commanded until the corresponding measured temperatures indicate an increase of at least 10 degrees.

## **07. FAIL SAFE DOOR OPERATION (FSD)**

### **FSD.1 Approval for Opening**

- (i) Because the fail-safe door cannot be closed after opening, the aperture door shall be certified as permanently inoperable prior to FSD opening.
- (ii) The PI and PM must both provide written approval prior to FSD opening.

### **FSD.2 Opening**

- (i) *Alice* shall be in a safe attitude.
- (ii) *Alice* shall have all measured temperatures within their nominal operating range, i.e.,  $-20 < T < +50$  C at the temperature reference point.
- (iii) HV shall be off.
- (iv) Near real-time monitoring is desired.

## **08. HEATER OPERATIONS (HOP)**

### **HOP.1 Operations**

- (i) There does not exist a maximum heater operation time.

## **09. PERMANENT PARAMETER LIST UPDATE (PLU)**

### **PLU.1 Certification**

- (i) The PM must authorize any update of the permanent parameter list (saved in the *Alice* context) in writing.
  - (ii) Such authorization, including the revised Parameter List and the reason for each change shall be recorded in the *Alice* Flight Operations Log.

## **10. SAFETY MASK UPDATES**

### **SMU.1 Certification**

- (i) The PM must authorize any update of the Safety Mask (saved in the *Alice* context) in writing.
- (ii) Such authorization, including the revised Safety Mask and the reason for each change shall be recorded in the *Alice* Flight Operations Log.

## **11. EEPROM MEMORY PATCH (EMP)**

### **EMP.1 Certification**

- (i) The PM must authorize any EEPROM memory patch in writing.
- (ii) Such authorization, including the reason for each memory patch shall be recorded in the *Alice* Flight Operations Log.



**EMP.2 Total Cycles**

- (i) The total number of EEPROM memory patch cycles since launch should not exceed 10,000 per EEPROM page (for a safety factor of 2), and should be rationed accordingly.
- (ii) Load new EEPROM beginning on modulo 128 byte (page) boundaries and write all 128 bytes at one time. (can do this 10,000 times in each 128 byte page).
- (iii) Maintain a single counter for each of the four 32 kbyte segments, do not maintain a counter for each 128 byte page.
- (iv) When uploading new code, write to one of the four segments, verify the load as accurate and then repeat for the other duplicate images.

**EMP.3 Refresh Rate**

- (i) Each EEPROM page should be refreshed or updated at least once every 5 years.
- (ii) EEPROM contents will be monitored (e.g., via checksums and/or memory dumps) annually to check for degradation, and updated more frequently than once per 5 years if monitor results show it to be necessary.

**12. HIBERNATION (HIB)**

**HIB.1 Prerequisites**

- (i) Hibernation operations shall be preceded by the PM’s written confirmation that the EEPROM memory and Parameter List are all suitable for post-hibernation power up.
- (ii) A 16-hr heater decontamination cycle shall have been completed <16 hours before entering hibernation.
- (iii) The Aperture Door shall be successfully closed and verified.
- (iv) The HV set-point (for use during normal acquisition operations) should be changed to a low (i.e., safe) value before entering hibernation.

**HIB.2 Configuration**

Alice shall be configured as follows:

- (i) HV off.
- (ii) Aperture door closed.
- (iii) LV off.

† Flight rules marked by a dagger were one-time operations performed during instrument Commissioning activities; they are no longer applicable.

**3.3 Failure Detection and Recovery Strategy**

The Alice instrument is a single string instrument. Accordingly, there is little that can be done in the event of a major system (e.g. HVPS, vacuum door, etc.) failure. Table 3-2 summarizes the possible failure modes and describes the consequences of each. See the *Alice Failure Modes Criticality Analysis* for a detailed discussion of possible spacecraft interface failure modes and their consequences.

*Table 3-2. Alice Failure Modes & Possible Recovery Operations*

<i>System</i>	<i>Failure</i>	<i>Response</i>
Detector Vacuum Door	Failure to Open	Operation with the detector vacuum door closed results in a loss of science below 1150 Å, but is not fatal to all science
Front Aperture Door	Failure to Open	Open the aperture door “fail-safe door” to accept limited light throughput (~5% throughput).

<i>System</i>	<i>Failure</i>	<i>Response</i>
Detector HVPS	Failure of HVPS	Not recoverable.
Detector electronics	Failure of component	Depending on failed component may be recoverable.
C&DH electronics	Failure of component	Depending on failed component may be recoverable.
Power Controller electronics	Failure of DC/DC Converter	Not recoverable.

The following *Alice* in-flight anomalies are listed in the Rosetta document SY-CRP-000 (Ground Monitoring Recovery Actions, Issue 5.2, dated July 17, 2006), with the designated appropriate actions necessary (see Table 3-3 for the *Alice* related “event-list” and Table 3-4 for the “parameter-list”; these are excerpts from the SY-CRP-000 Rosetta document).

Table 3-3. *Alice* In-Flight Monitoring/Recovery Event-List Table (per SY-CRP-000)

Name	Description	Subtype	Event ID	Action	CRP Ref	Remark
YAL00003	DoorErrorWarningEvent	2	40002	Log as unexpected in daily report.		
YAL00005	ParameterReadWarningEvent	2	40004	Log as unexpected in daily report.		
YAL00006	ParameterReadErrorEvent	4	40005	Call engineer.		This event is on the on-board event monitoring list (service 12). Its recovery action shall be enabled by the ALICE switch ON procedure. Recovery action: ALICE switch-OFF (OBCP 8012).
YAL00007	SafetyGroundEvent	3	40006	Call engineer.		
YAL00008	SafetyOnBoardEvent	4	40006	Call engineer.		This event is on the on-board event monitoring list (service 12). Its recovery action shall be enabled by the ALICE switch ON procedure. Recovery action: ALICE switch-OFF (OBCP 8012).
YAL00016	AcquisitionWarningEvent	2	40008	Log as unexpected in daily report.		

Table 3-4. Alice In-Flight Monitoring/Recovery Parameter-List Table (per SY-CRP-000)

NAME	Description	Cattype	Eng. Label	Limit set	Action	CRP Ref.	Remark
NALA0002	Ins Det Cnt Rate	NONE	Hz	LAL00023	Call engineer.		
NALA0003	Min Det Cnt Rate	NONE	Hz	LAL00023	Call engineer.		
NALA0004	Max Det Cnt Rate	NONE	Hz	LAL00023	Call engineer.		
NALA0016	Unsafe Timer	NONE	sec	LAL00029	Call engineer for investigation.		ALICE has entered unsafe conditions. First action: call PI and check instrument status. Which alarm has triggered is indicated by the 'safety' flags.
NALD0107	Operating State	DIG	0	LAL00041	Call engineer for investigation.		ALICE TM reports illegal operating state.
NALD0501	HV Set Point	ANA	kV	LAL00040	Call engineer		
NALD0502	Ins MCP Voltage	ANA	kV	LAL00024	Call engineer.		
NALD0601	Min MCP Voltage	ANA	kV	LAL00024	Call engineer.		
NALD0602	Max MCP Voltage	ANA	kV	LAL00024	Call engineer.		
NALD0701	Ins Anod Voltage	ANA	V	LAL00025	The OOL is expected if it occurs while parameter NALD0101 switched from OFF to ON. Otherwise call engineer.		This parameter is expected for a few samples after ALICE High Voltage switch-on (NALD0101 changes from Off to ON).
NALD0702	Min Anod Voltage	ANA	V	LAL00025	The OOL is expected if it occurs while parameter NALD0101 switched from OFF to ON. Otherwise call engineer.		This parameter is expected for a few samples after ALICE High Voltage switch-on (NALD0101 changes from Off to ON).
NALD0801	Max Anod Voltage	ANA	V	LAL00025	The OOL is expected if it occurs while parameter NALD0101 switched from OFF to ON. Otherwise call engineer.		This parameter is expected for a few samples after ALICE High Voltage switch-on (NALD0101 changes from Off to ON).
NALD0802	Ins Strip Curr	ANA	uA	LAL00026	Call engineer.		
NALD0901	Min Strip Curr	ANA	uA	LAL00026	Call engineer.		
NALD0902	Max Strip Curr	ANA	uA	LAL00026	Call engineer.		
NALD1001	Mirror Temp Pri	ANA	degC	LAL00027	Call engineer.		
NALD1002	Mirror Temp Sec	ANA	degC	LAL00027	Call engineer.		
NALD1102	Grating Temp Pri	ANA	degC	LAL00028	Call engineer.		
NALD1201	Grating Temp Sec	ANA	degC	LAL00028	Call engineer.		
NALD1701	Dust Safety	DIG	0	LAL00030	Call engineer for investigation.		ALICE has entered unsafe conditions. First action: call PI and check instrument status.

NALD1702	Bright Safety	DIG	0	LAL00030	Call engineer for investigation.		ALICE has entered unsafe conditions. First action: call PI and check instrument status.
NALD1703	Trend Safety	DIG	0	LAL00030	Call engineer for investigation.		ALICE has entered unsafe conditions. First action: call PI and check instrument status.
NALD1704	Press Alert Safety	DIG	0	LAL00030	Call engineer for investigation.		ALICE has entered unsafe conditions. First action: call PI and check instrument status.
NALD1705	HVPS Safety	DIG	0	LAL00030	Call engineer for investigation.		ALICE has entered unsafe conditions. First action: call PI and check instrument status.
NALD1706	Temp Safety	DIG	0	LAL00030	Call engineer for investigation.		ALICE has entered unsafe conditions. First action: call PI and check instrument status.
NALD1707	Safety Override	DIG	0	LAL00031	Call engineer.		
NALD1708	Dust Mask	DIG	0	LAL00032	Call engineer.		
NALD1709	Bright Mask	DIG	0	LAL00032	Call engineer.		
NALD1710	Trend Mask	DIG	0	LAL00032	Call engineer.		
NALD1711	Press Alert Mask	DIG	0	LAL00032	Call engineer.		
NALD1712	HVPS Mask	DIG	0	LAL00032	Call engineer.		
NALD1713	Temp Mask	DIG	0	LAL00032	Call engineer.		
NALD1801	Det Elec Temp	ANA	degC	LAL00033	Call engineer.		
NALD1802	Det Housing Temp	ANA	degC	LAL00034	Call engineer.		
NALD1901	C&DH Elec Temp	ANA	degC	LAL00035	Call engineer.		
NALD1902	Instr Hous Temp	ANA	degC	LAL00036	Call engineer.		
NALD2002	Major SW Version	NONE	0	LAL00038	Call engineer.		
NALD2003	Minor SW Version	NONE	0	LAL00039	Call engineer.		
NALD3702	Dust Safety	DIG	0	LAL00030	Call engineer for investigation.		ALICE has entered unsafe conditions. First action: call PI and check instrument status.
NALD3703	Bright Safety	DIG	0	LAL00030	Call engineer for investigation.		ALICE has entered unsafe conditions. First action: call PI and check instrument status.
NALD3704	Trend Safety	DIG	0	LAL00030	Call engineer for investigation.		ALICE has entered unsafe conditions. First action: call PI and check instrument status.
NALD3705	Press Alert Safety	DIG	0	LAL00030	Call engineer for investigation.		ALICE has entered unsafe conditions. First action: call PI and check instrument status.
NALD3706	HVPS Safety	DIG	0	LAL00030	Call engineer for investigation.		ALICE has entered unsafe conditions. First action: call PI and check instrument status.
NALD3707	Temp Safety	DIG	0	LAL00030	Call engineer for investigation.		ALICE has entered unsafe conditions. First action: call PI and check instrument status.
NDMW021A	Auto-WOL Status	DIG		LDMX0012	An OOL on this parameter is expected after a safe mode and when the Auto-WOL function is re-enabled by ground command (AC-FCP-125). In all cases where this parameter becomes out-of-limit, check that ROSINA, ALICE and RPC are switched-off. If one of the PL is active, call engineer.		

NPWDA570	ALICE PS1, PLCL 11A CUR	ANA	A	LPW03140	Call engineer.		Parameter on DMS monitoring list (service 12). Monitoring status controlled by ALICE switch ON procedure. Recovery action: start ALICE OFF OBCP (OBCP 8012).
NPWDA578	SPARE, PLCL 12A CUR	ANA	A	LPW03141	Call engineer.		
NPWDA580	AL HIB HTR, PLCL 13A CUR	ANA	A	LPW03069	Call engineer.		
NPWDA890	ALICE PS2, PLCL 11B CUR	ANA	A	LPW03206	Call engineer.		Parameter on DMS monitoring list (service 12). Monitoring status controlled by ALICE switch ON procedure. Recovery action: start
NTSA0062	#001 ALICE TRPP	ANA	degC	LTS00001	Call engineer.		
NTSA0188	#002 ALICE TRPR	ANA	degC	LTS00002	Call engineer.		

## 4 Mode Descriptions

### 4.1 Mode Transition Table

See Section 2.2.7 for detailed description of the instrument states; Section 2.3.3 with respect to data generation rates; and Section 2.3.2 for the relation to power consumption.

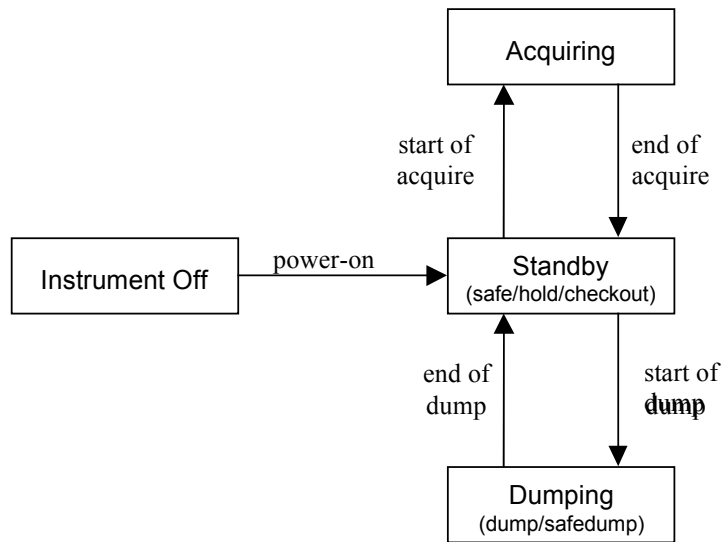

Figure 4.1-1. The Alice top-level mode transitions.

When *Alice* is performing science data acquisitions in response to a Multiple Acquire Dump (MAD) telecommand the operating state (reported in the *Alice* HK packet) may change. Depending on the parameters specified with the MAD command, the instrument will cycle through different states before completing the command:

- Acquire state: when an acquisition time has been specified, the instrument will start with an acquire phase of the specified duration.
- Dump state: when one or multiple dumps have been specified, the science data packets will be generated and sent to the spacecraft.
- Standby state: when instrument is not acquiring and not dumping, this occurs before and after execution of a MAD command but it can also occur when a cycle time has been

specified that is larger than the combined acquire and dump time, the remainder of the time will be spent in this state.

The MAD command will either end in the Hold state when the MAD command has completed normally, or Safe when the MAD command was terminated because of a safety condition.

In all the above instrument states (Acquire, Dump, and Standby), the power draw is specified in Table 2-6 for Mode 1 when the HVPS is not at full operational level, and for Mode 2 when the HVPS is fully activated at the operational HV level. The power in Mode 3 of Table 2-6 only occurs when the optical heater elements are also engaged and operating during optical decontamination sessions (see Section 2.1.4). Note that due to limitations of the Rosetta instrument modeling for Alice power generation, the Rosetta model used during the comet escort phase assumes that whenever Alice is ON that the power use is the maximum possible of the predicted average power, i.e., 6.3 W.

When *Alice* is acquiring science data and receives an 'Enter Safe State' telecommand, only the current acquisition cycle is terminated. This means that if a MAD command specified multiple acquisition cycles, the acquisition will re-start when the next cycle is due. To terminate a MAD command the 'Stop Acquisition' telecommand has to be used. This command will cause the *Alice* instrument to terminate the completed acquisition command and return to the Safe state. In this case, the MAD command returns an Execution failure state and the 'Stop acquisition' command will return an Execution success status, both when requested.

## 4.2 Detailed Mode Descriptions

See Section 2.2.7

# 5 Operational Procedures (DRD 51.2)

## 5.1 Ground Test Sequences

The *Alice* ground test sequences are summarized below. Detailed procedures for each test sequence are referenced in Table 5-1. All the *Alice* electrical functional tests are run with the *Alice* HVPS set at 0 volts (with the *Alice* HV safing plug installed), or at a low level of -250 V (with the HV safing plug removed). An *Alice* team member must be on site during *Alice* ground tests whenever the HV safing plug is removed. This is also applicable to all the SPT tests (see below) that require commanding the *Alice* HVPS to its full operational level (-4 kV).

**Bench Test (BT).** The *Alice* BT shall verify the electrical functionality of the *Alice* instrument excluding operation of the detector HVPS to its full operational HV level (~4 kV). Instead, the HVPS will be commanded to a low HV setting of ~250 V; the detector can be safely operated at this low HV level while backfilled at 1 atm GN<sub>2</sub>. This test will be performed at delivery to the S/C contractor (Alenia), with *Alice* on the bench in a suitable clean room environment. The BT will consist of the *Alice* “Full Functional Test” procedure 8225-FTP-01. An SPT (see below) will also be conducted during the *Alice* BT. The FFT and SPT tests must only be run with *Alice* team members present. The HV safing plug must be removed to run this test.

**Unit Functional Test (UFT).** The *Alice* UFT shall verify the full electrical functionality of the *Alice* instrument excluding operation of the detector HVPS. This test will be performed after integration of *Alice* onto the S/C and will represent the baseline functionality test of *Alice* post S/C integration. The UFT will consist of i) the *Alice* “Full Functional Test” procedure 8225-FTP-01, followed by ii) the *Alice* Full Functional Test scripts as outlined in SwRI Technical Note “Test Sequence Definitions for *Alice* Flight Software (8225-TEST\_DEF-01). These tests must only be run with *Alice* team members present. The HV safing plug must be installed to run these tests.

**Integrated System Test (IST).** The *Alice* IST shall verify the full electrical functionality of the *Alice* instrument excluding operation of the detector HVPS. This test will be conducted using the *Alice* Full Functional Test scripts as outlined in SwRI Technical Note “Test Sequence Definitions for *Alice* Flight Software (8225-TEST\_DEF-01). The IST will be performed 1) following payload integration, 2) after major spacecraft transportation, 3) during S/C EMI/EMC tests<sup>1</sup>, 4) following the S/C vibration test, 5) following the S/C thermal balance/thermal vacuum test, and 6) upon completion of the full system level verification program prior to S/C shipment to the launch site. These tests must only be run with *Alice* team members present. The HV safing plug must be installed to run these tests (except during the EMI/EMC test when the HVPS is commanded to –250 V).

**Mission Simulation Test (MST).** The MST is designed to test S/C operations during the asteroid flyby encounter. The test is mainly aimed at testing the S/C operations, but the experiments are used to generate a realistic data flow. The *Alice* test sequences used during the Thermal Vacuum / Thermal Balance tests will be re-used; these test sequences put *Alice* in different acquisition modes without activating the *Alice* detector HVPS.

**Specific Performance Test (SPT).** The *Alice* SPT shall verify the electrical and radiometric functionality of the *Alice* instrument with operation of the detector and HVPS, concurrent with UV stimulation of the instrument via a portable GSE UV light source attached to the front of the *Alice* housing. The SPT test will be conducted using the *Alice* “End-to-End Radiometric Test (S/C version)” procedure 8225-ETE\_RAD\_SC-01. This test will be performed 1) during the BT at delivery to the S/C contractor (Alenia), 2) during IST following payload integration, 3) following the S/C vibration test, 4) upon completion of the full system level verification program prior to S/C shipment to the launch site, and 5) at the launch site. To conduct this test, it is necessary to pump down the *Alice* detector housing to a high vacuum level ( $< 10^{-5}$  Torr) using the *Alice* GSE vacuum pump station and associated GSE vacuum manifold (see Figure 2.2-1b). A special GSE rack contains the vac-ion HVPSs and pressure gauge controller necessary to operate the vacuum manifold during the SPT. Long HV cables (~5 m) connect this rack with the vac-ion pumps and CCG gauge on the manifold. Following the completion of the SPT, the detector vacuum housing must backfilled with high purity grade GN<sub>2</sub> (MIL-P-27401C Grade C or better). The SPT test must only be run with *Alice* team members present. The HV safing plug must be removed to run this test.

**Abbreviated Functional Test (AFT).** The *Alice* AFT is a limited functional test of the *Alice* instrument excluding operation of the detector HVPS. This test will be conducted using the *Alice* Abbreviated Functional Test scripts as outlined in SwRI Technical Note “Test Sequence Definitions for *Alice* Flight Software (8225-TEST\_DEF-01). It will be performed 1) following the S/C acoustic/shock tests, 2) during the S/C thermal balance/thermal vacuum test, and 3) to verify system electrical integrity following local movement of the S/C (when necessary).

**System Validation Test (SVT).** The SVT is a closed loop test of the S/C, the *Alice* payload, the overall ground segment, and the flight control software. The S/C will be controlled from ESOC. It will be conducted upon completion of the full system level verification program prior to S/C shipment to the launch site.

Table 5-1. PFM Ground Test Sequences/Verification Test Matrix

Test Type	Applicable Test Procedure(s)	Alice HV Level	When in AIV Test Program
BT	8225-FTP-01	-250 V	• Post <i>Alice</i> delivery to Alenia
UFT	8225-FTP-01 8225-TEST_DEF-01	0 V	• Post <i>Alice</i> integration to S/C
IST	8225-TEST_DEF-01	0 V*	• Post <i>Alice</i> integration to S/C • Post major S/C transport

<sup>1</sup> During the EMI/EMC IST test, *Alice* will be powered on and the *Alice* HVPS will be commanded to the low HV level of –250 V.

<i>Test Type</i>	<i>Applicable Test Procedure(s)</i>	<i>Alice HV Level</i>	<i>When in AIV Test Program</i>
			<ul style="list-style-type: none"> <li>• S/C EMI/EMC tests</li> <li>• Post S/C vibration tests</li> <li>• Post S/C TB/TV tests</li> <li>• Pre S/C shipment to launch site</li> </ul>
MST	N/A	0 V	<ul style="list-style-type: none"> <li>• S/C SFT operational phases</li> </ul>
SPT	8225-ETE-RAD_SC-01 8225-DET_PUMPDOWN-01 8225-TEST_DEF-01	-4.1 kV (full operational level)	<ul style="list-style-type: none"> <li>• Post <i>Alice</i> delivery to Alenia</li> <li>• Post <i>Alice</i> integration to S/C</li> <li>• Post S/C vibration tests</li> <li>• Pre S/C shipment to launch site</li> </ul>
AFT	8225-TEST_DEF-01	0 V	<ul style="list-style-type: none"> <li>• Post S/C acoustic/shock tests</li> <li>• During S/C TB/TV tests</li> <li>• Post local S/C movement</li> </ul>
SVT	8225-SVT_DEF-01	0 V	<ul style="list-style-type: none"> <li>• Pre S/C shipment to launch site</li> </ul>
* The HVPS will be commanded to -250 V in the IST run during EMI/EMC tests.			

## 5.2 On-Board Control Procedures

See Section 6.9.

## 5.3 Flight Control Procedures

**Commissioning Phase:** see FOP (RO-ESC-PL-5000), Section 5.1.

**All other mission phases:** See FOP (RO-ESC-PL-5000), Section 5.1.

## 5.4 Contingency Recovery Procedures (EID-B, §6.5.4)

The following contingencies have been identified along with possible recovery procedures:

### Detector door does not indicate open

If the detector door does not indicate open after initial commanding (during *Alice* Commissioning Phase I), several re-attempts will be made over time. If door still does not indicate open (or detector door open indicator is faulty), then commissioning will proceed except for the application of HV, which may be delayed to insure that the GN<sub>2</sub> gas inside the detector vacuum housing has fully leaked out to prevent HV arcing<sup>2</sup>. When the commissioning has resumed *Alice* science will take place in a degraded condition (lower UV throughput and smaller spectral passband of 1200-2050 Å). In the latter phases of *Alice* commissioning (*Alice* Commissioning Phase III), science acquisitions will begin which will make it possible for the *Alice* team to determine whether or not the door is actually open or closed (to ascertain whether or not the detector door switch is faulty).

### Aperture door close sensor always indicates closed

If the aperture door close sensor continues to indicate closed after commanding open, then a door-warning event will be generated. If this happens, the *Alice* team will request time to perform engineering diagnostics. The indication from the door open sensor will be considered. If it behaves as expected then the door close sensor will be suspected faulty. One or more science observations will be made to determine if the door is really open, in which case the sensor will be declared faulty. If this happens then

<sup>2</sup> The detector vacuum housing is backfilled with GN<sub>2</sub> during launch to prevent degradation of the sensitive detector photocathodes from exposure to air that could leak into the housing if left under vacuum.



operation will proceed normally with the understanding that the door close sensor is faulty. If it appears that the sensor is correctly indicating that the door remains closed then several re-attempts will be made to open the door, possibly including lengthening the amount of time that the door motor is activated (this is a configurable parameter). If it determined that the door is actually stuck closed and cannot be opened, then at some point the decision will be made to open the fail-safe door, which is a one-time operation. This decision would likely be made only after some amount of time has passed and the *Alice* team feels certain that the door is permanently stuck closed.

#### Aperture door open sensor always indicates open

If the aperture door open sensor continues to indicate open after commanding closed, then a door warning event will be generated. If this happens then the *Alice* team will request time to perform engineering diagnostics. During this period, Flight Rules should be followed assuming the door is open. The indication from the door close sensor will be considered. If it behaves as expected then the door open sensor will be suspected faulty. One or more science observations will be made to determine if the door is really closed, in which case the sensor will be declared faulty. If this happens then operation will proceed normally with the understanding that the door open sensor is faulty. If it appears that the sensor is correctly indicating that the door remains open then the *Alice* team will carefully consider whether it is worth further attempting to move the door for fear of having the door become stuck in the closed position. *Alice* can be configured by parameter to not attempt to close the door, and operations can proceed normally in this configuration except that the door will not be closed when *Alice* is safed or shut down.

#### Aperture door sensors indicate conflicting positions

If the aperture door sensors indicate that the door is both open and closed, or a continuous indication of being neither open nor closed, then a door warning event will be generated. If this happens then the *Alice* team will request time to perform engineering diagnostics. During this period, Flight Rules should be followed assuming the door is open. A troubleshooting approach will be devised based on the indications from the sensors. One or more science observations will be made to determine the actual position of the door. This situation will most likely indicate that one or both of the sensors is faulty rather than sticking of the door. In this case the likely response will be to proceed normally using alternate information source (such as detector count rates) to determine that the door is in the expected position.

#### Heater temperature sensor disagreement

*Alice* has two temperature sensors for each of two heaters. If the two sensors disagree by more than 5 degrees C, then one of the sensors will be suspected faulty. Then by comparing the temperature sensor levels to the other temperature sensors in the instrument, or by observing the sensor responses to activation of the heater, an attempt will be made to determine which sensor is providing correct values. The instrument will then be commanded, by setting a parameter value, to use the "good" sensor for heater temperature regulation.

#### Heater temperature sensor loss

If both temperature sensors for a given heater are suspected faulty, then operation of the *Alice* heaters will switch to an open-loop timeline commanded method. The *Alice* team will compute the appropriate on and off times for the heater(s) based on thermal models and collected flight data (to that point in the mission), and those times will be set in the timeline.

#### High voltage safety condition

If any of several HV power supply operating parameters goes out of limits, then a high voltage safety condition will be in effect and *Alice* will be safed. A safety event telemetry packet will be generated. If this happens then the *Alice* team will request time to perform engineering diagnostics. Tests will be performed on the HVPS to determine if the problem is temporary or permanent. If the problem is temporary and can be explained then normal operation will resume. If it appears that a normal operating

parameter has changed, due to aging for example, then the safety threshold limits can be adjusted to account for the new operating parameters.

#### Temperature safety condition

If any temperature sensor exceeds a preset limit, then a temperature safety will be in effect and *Alice* will be safed. A safety event telemetry packet will be generated. The data in the packet will indicate which temperature sensor caused the safety. If it is determined that the temperature sensor in question is faulty, then that temperature sensor can be excluded, by setting a parameter, from being considered in future temperature safety determination. If the temperature sensor is reading just a little above the limit, and this is determined acceptable, then the temperature safety limit can be raised by changing a parameter. If it is determined that the temperature sensor is truly indicating some kind of overheating in the instrument, then *Alice* will be shut down while an alternate operating strategy is devised. Such strategy could include reducing the amount of time that *Alice* is powered in order to reduce heating.

#### Dust level safety condition (alert)

If the reported dust flux exceeds a certain limit, then a dust alert safety condition will be in effect and *Alice* will be safed. A safety event telemetry packet will be produced. A determination will be made whether or not the reported dust flux value is correct. If so, then normal operation will resume when the dust level drops to a safe value. If the dust level reported is determined to be in error, then *Alice* will be reconfigured to ignore the reported dust level.

#### Pressure safety condition (trend or alert)

If the reported pressure level, or pressure trend calculation exceeds a certain limit, then a pressure safety condition will be in effect and *Alice* will be safed. A safety event telemetry packet will be produced. A determination will be made whether or not the reported pressure value is correct. If so, then normal operation will resume when the pressure level drops to a safe value. If the pressure level reported is determined to be in error, then *Alice* will be reconfigured to ignore the reported pressure level.

#### Bright object safety condition

If the detector count rate exceeds a preset limit, then a bright object safety condition will be in effect and *Alice* will be safed. A safety event telemetry packet will be generated. If this happens then the *Alice* team will request time to perform engineering diagnostics. First consideration will be whether the high count rate can be explained by the spacecraft pointing configuration (i.e. pointed at the sun or a bright UV star). If the high count rate can be explained, then normal operation will resume. If the high count rate cannot be explained, then diagnostics will be performed on the high voltage power supply in an attempt to determine the source of the problem, and to determine if this is a temporary (from HV arcing for example) or a permanent (detector hot spot) condition. If it is determined that the condition is permanent but *Alice* is still usable, then the count rate safety threshold will be raised by setting a parameter, and normal operation will resume.

#### Required software modification

If a problem develops with *Alice* that requires a software modification, then the *Alice* team will produce a software patch. After the patch is installed in *Alice*, normal operation will resume, but using the "patched startup" OBCP for starting *Alice*. See the Data Operations Handbook (DRD 65.2).

#### S/C Detected Out-of-Limits

If the S/C detects an "out-of-limits" during an *Alice* acquisition sequence (see Table 5-2 and EID-B §2.8 for a list of *Alice* housekeeping parameters monitored by the S/C), then the S/C will send a telecommand (TC) to *Alice* to enter the SAFE state, followed shortly thereafter with a command to power *Alice* off. Commanding *Alice* to the SAFE state will switch off the HVPS and (if enabled) close the aperture door.

If *Alice* is running a MAD acquisition with multiple acquisitions in sequence commanded the change to safe state will only terminate the current active acquisition (and switch to safe state). It will not, however, terminate the actual MAD acquisition sequencing. When the next scheduled acquisition start moment arrives the nominal acquisition start sequence is executed, including HV on, door open etc. Hence, if a long MAD sequence of acquisitions was stopped somewhere in the middle because of a temporary safety condition the MAD would continue and after expiring the safety time-out (which would initially be set to a large value), further acquisitions would be taken. For example, if acquisitions were commanded to start every 10 minutes past the hour, this time schedule would be upheld and a start acquisition would only be attempted at 10 minutes past the hour for as long as the overall MAD was in effect.

Table 5-2. List of Spacecraft Monitored Alice Housekeeping Parameters

DMS MONITORING		Instrument	Alice
Monitored Entity	Monitoring Requirements	Action on Error	
<b>Parameters</b>			
Alice LCL current	current should remain $\leq 0.4$ A	turn <i>Alice</i> off	
Operating state limits	$0 \leq \text{LAL00021} \leq 5$	turn <i>Alice</i> off	
Count rate limits	$0 \text{ Hz} \leq \text{LAL00023} \leq 22000 \text{ Hz}$	turn <i>Alice</i> off	
MCP V limits	$-4100 \text{ Volt} \leq \text{LAL00024} \leq 0 \text{ Volt}$	turn <i>Alice</i> off	
Anode V limits	$-650 \text{ Volt} \leq \text{LAL00025} \leq 0 \text{ Volt}$	turn <i>Alice</i> off	
Strip I limits	$0 \mu\text{A} \leq \text{LAL00026} \leq 10 \mu\text{A}$	turn <i>Alice</i> off	
Mirror Temp limits	$-30^\circ\text{C} \leq \text{LAL00027} \leq 65^\circ\text{C}$	turn <i>Alice</i> off	
Grating Temp limits	$-30^\circ\text{C} \leq \text{LAL00028} \leq 60^\circ\text{C}$	turn <i>Alice</i> off	
Det Elec Temp limits	$-30^\circ\text{C} \leq \text{LAL00033} \leq 60^\circ\text{C}$	turn <i>Alice</i> off	
Det Housing Temp limits	$-30^\circ\text{C} \leq \text{LAL00034} \leq 65^\circ\text{C}$	turn <i>Alice</i> off	
Instr Elec Temp limits	$-30^\circ\text{C} \leq \text{LAL00035} \leq 60^\circ\text{C}$	turn <i>Alice</i> off	
Instr Housing Temp limits	$-30^\circ\text{C} \leq \text{LAL00036} \leq 65^\circ\text{C}$	turn <i>Alice</i> off	
Major version limits	$\text{LAL00038} \neq 2$	turn <i>Alice</i> off	
Minor version limits	$\text{LAL00039} \neq 4$	turn <i>Alice</i> off	
High Voltage Set Point	$-4050 \text{ Volt} \leq \text{LAL00040} \leq 0 \text{ Volt}$	turn <i>Alice</i> off	
<b>Events</b>			
Parameter read error event	When read error event is reported	turn <i>Alice</i> off	

## 6 Data Operations Handbook (DRD 65.2)

This section presents a detailed description of the *Alice* telemetry and telecommand data formats within the framework defined by Rosetta. The Rosetta TM/TC concept is based on a number of standard services with related requests (telecommands) and reports (telemetry) and specifies packets within the CCSDS telemetry and telecommand standards. Each packet is identified by a service and a sub-type number. The *Alice* instrument supports all the standard services. The instrument specific telecommands are captured in the Private telecommands section. In the table below, an overview of the requests and reports is given. The separate telecommand and telemetry packets are described in detail in the two sections following this table.

Sub-Type	Service Requests (TC)	Sub-Type	Service Reports (TM)
<b>Service 1 - TC Acknowledge</b>			
		1	Acceptance Acknowledge - Success
		2	Acceptance Acknowledge - Failure
		7	Execution Acknowledge - Success
		8	Execution Acknowledge - Failure
<b>Service 3 - Housekeeping Reporting</b>			
5	Enable HK Report	25	HK Report (per SID)
6	Disable HK Report		
<b>Service 5 - Event Reporting</b>			
		1	Normal Progress Report
		2	Error Report - no action
		3	Error Report - ground action
		4	Error Report - on-board action
<b>Service 6 - Memory Management</b>			
2	Load Memory		
5	Dump Memory	6	Memory Dump
9	Check Memory	10	Memory Check
<b>Service 9 - Time Management</b>			
1	Accept Time Update		
<b>Service 17 - Test Connection</b>			
1	Connection Test Request	2	Connection Test Report
<b>Service 18 - Context Transfer</b>			
1	Report Context	2	Context Report
3	Accept Context		
<b>Service 19 - Information Distribution</b>			
10	Rosina COPS Pressure Distribution		
11	Rosina COPS Pressure Alert		
12	Giada Dust Monitor		
<b>Service 20 - Science Data Transfer</b>			
1	Enable Science Report (RTU)	3	Science Report (RTU)
2	Disable Science Report (RTU)		
<b>Service 192 - Private Telecommands</b>			
1	Enter Safe State		
2	Enter Checkout State		
3	Confirm Critical Command		
4	Deleted (was Acquire Histogram Mode)		
5	Deleted (was Acquire Pixel Mode)		
6	Deleted (was Acquire Count Rate Mode)		
7	Stop Acquisition		
8	Deleted (was Dump Science Data)		
9	Deleted (was Stop Science Data Dump)		

Sub-Type	Service Requests (TC)	Sub-Type	Service Reports (TM)
10	Clear Acquisition Memory		
11	Set Parameter		
12	Set Safety Mask		
13	Set Safety Override		
14	Open Aperture Door		
15	Close Aperture Door		
16	Set High Voltage On		
17	Set High Voltage Off		
18	Set Heater On		
19	Set Heater Off		
20	Set Stimulator On		
21	Set Stimulator Off		
22	Set Discriminator Level		
23	Perform Self Test		
24	Start Program		
25	Get Parameters		
26	Multiple Acquire Dump		
<b>Service 255 - Common Private Telecommands</b>			
1	Reset Telemetry Output Buffer		

### 6.1 Telecommand Packet and Parameter Definitions

Before accepting any telecommand packet *Alice* will verify the correct APID, the declared length (length field in the telecommand) and the CRC for the received packet. If any of these three checks fail the telecommand is not accepted and if requested by the ‘acceptance acknowledgement’ header bit an appropriate telecommand acceptance failure telemetry packet (1,2) is generated. The specific acceptance rules for the different telecommands are described with each telecommand definition. If for a specific packet correct packet length is mentioned as an acceptance criteria this means that the length is compared to the expected length for this specific telecommand.

<b>Telecommand Packet Definition (<i>Alice</i>)</b>			
Packet Name	Enable/Disable Housekeeping Generation	Instrument	<i>Alice</i>
Packet Function	enable/disable instrument housekeeping output		
Verification Rules	acceptance: correct packet length and SID check execution: always		
<b>Header Information</b>			
Process ID	92	Packet Category	12
Service Type	3	Service Subtype	5, 6 (see notes)
Structure ID	N/A	Packet Length	2 data
<b>Data Field Information</b>			
Data Field	Field Structure	Remarks	
SID	enum (16)	structure identifier of HK type (always 1 for <i>Alice</i> )	
<b>Notes:</b> Sub-type 5 enables the specified SID, sub-type 6 disables the specified SID. <i>Alice</i> only has one HK SID (=1). <i>Alice</i> HK is disabled at startup, but <i>Alice</i> will, when not enabled earlier, enable HK generation 40 seconds after startup and start generating HK packets.			

<b>Telecommand Packet Definition (<i>Alice</i>)</b>			
Packet Name	Load Memory	Instrument	<i>Alice</i>
Packet Function	load instrument memory with new values		
Verification Rules	acceptance: memlength consistent with packet length, valid writable memory ID (PROM can't be written to), one block specified, code executed from PROM when loading EEPROM, detector memory specification does not cross 16k byte page boundary, EEPROM memory specification does not cross 128 byte block border and instrument state is checkout. execution: always		
<b>Header Information</b>			
Process ID	92	Packet Category	12
Service Type	6	Service Subtype	2
Structure ID	N/A	Packet Length	variable
<b>Data Field Information</b>			

Data Field	Field Structure	Remarks
MemoryId	enum (8) (see notes)	Identifies memory type of load
Blocks	unsigned (8)	number of memory blocks in packet, <b>must be 1</b>
MemStart	unsigned (32)	memory starting address of this block (word address)
MemLength	unsigned (16)	number of words in block
MemData	unsigned (16) * MemLength	memory data to be loaded, must always be even number of bytes; this field is repeated for the number of words specified by MemLength
<b>Notes:</b> Memory types (MemoryId) defined in memory dump telemetry packet (6,6). Only single block load packets are supported. Packet data field length is 8 + MemLength * 2.		

Telecommand Packet Definition (Alice)			
Packet Name	Dump Memory	Instrument	Alice
Packet Function	dump instrument memory		
Verification Rules	acceptance: correct packet length, valid memory ID, one block specified, detector memory specification does not cross 16k byte page boundary, EEPROM memory specification does not cross 8k byte page boundary and instrument state is checkout. execution: always		
<b>Header Information</b>			
Process ID	92	Packet Category	12
Service Type	6	Service Subtype	5
Structure ID	N/A	Packet Length	8 data
<b>Data Field Information</b>			
Data Field	Field Structure	Remarks	
MemoryId	enum (8) (see notes)	identifies memory type of dump	
Blocks	unsigned (8)	number of memory blocks to dump, <b>must be 1</b>	
MemStart	unsigned (32)	memory starting address of this block	
MemLength	unsigned (16)	number of words in block	
<b>Notes:</b> Memory types (MemoryId) defined in memory dump telemetry packet (6,6). Only single block packets are supported. Multiple dump TM packets may be generated in response (6,6). This telecommand executes in the slow thread (only one "slow" TC at a time).			

Telecommand Packet Definition (Alice)			
Packet Name	Check Memory	Instrument	Alice
Packet Function	perform check sum of instrument memory		
Verification Rules	acceptance: correct packet length, valid memory ID, one block specified, detector memory specification does not cross 16k byte page boundary, EEPROM memory specification does not cross 8k byte page boundary and instrument state is checkout. execution: always		
<b>Header Information</b>			
Process ID	92	Packet Category	12
Service Type	6	Service Subtype	9
Structure ID	N/A	Packet Length	8 data
<b>Data Field Information</b>			
Data Field	Field Structure	Remarks	
MemoryId	enum (8) (see notes)	identifies memory type to check	
Blocks	unsigned (8)	number of memory blocks to check, <b>must be 1</b>	
MemStart	unsigned (32)	memory starting address of this block	
MemLength	unsigned (16)	number of words in block	
<b>Notes:</b> Memory types (MemoryId) defined in memory dump telemetry packet (6,6). Only single block packets are supported. This telecommand executes in the slow thread (only one "slow" TC at a time).			

Telecommand Packet Definition (Alice)			
Packet Name	Time Update	Instrument	Alice
Packet Function	provide time synchronization update to instrument		
Verification Rules	acceptance: correct packet length execution: always		
<b>Header Information</b>			
Process ID	92	Packet Category	12
Service Type	9	Service Subtype	1

Structure ID	N/A	Packet Length	6 data
<b>Data Field Information</b>			
Data Field	Field Structure	Remarks	
SCET	CUC time (48)	spacecraft elapsed time, see notes for format	
<b>Notes:</b> Time is formatted as 32 bits of whole seconds and 16 bits of fractional seconds. The upper bit of the seconds field is not used here (so there is effectively 31 bits of seconds). Execution is a no-operation when a Multiple Acquire Dump command is in progress			

<b>Telecommand Packet Definition (Alice)</b>			
Packet Name	Connection Test	Instrument	Alice
Packet Function	request connection test report		
Verification Rules	acceptance: always; execution: always		
<b>Header Information</b>			
Process ID	92	Packet Category	12
Service Type	17	Service Subtype	1
Structure ID	N/A	Packet Length	0 data
<b>Data Field Information</b>			
Data Field	Field Structure	Remarks	
This packet has no application data fields.			
<b>Notes:</b>			

<b>Telecommand Packet Definition (Alice)</b>			
Packet Name	Report Context	Instrument	Alice
Packet Function	request instrument produce context report (18,2)		
Verification Rules	acceptance: always; execution: always		
<b>Header Information</b>			
Process ID	92	Packet Category	12
Service Type	18	Service Subtype	1
Structure ID	N/A	Packet Length	0 data
<b>Data Field Information</b>			
Data Field	Field Structure	Remarks	
This packet has no application data fields.			
<b>Notes:</b> This telecommand executes in the slow thread (only one "slow" telecommand can execute at a time).			

<b>Telecommand Packet Definition (Alice)</b>			
Packet Name	Accept Context	Instrument	Alice
Packet Function	load internal parameter file (instrument context)		
Verification Rules	acceptance: correct packet length; execution: always		
<b>Header Information</b>			
Process ID	92	Packet Category	12
Service Type	18	Service Subtype	3
Structure ID	N/A	Packet Length	42 data
<b>Data Field Information</b>			
Data Field	Field Structure	Remarks	
context	42 bytes	see notes	
<b>Notes:</b> Data field contents same as context report (18,2). This telecommand executes in the slow thread.			

<b>Telecommand Packet Definition (Alice)</b>			
Packet Name	ROSINA pressure distribution	Instrument	Alice
Packet Function	provide ROSINA pressure to Alice		
Verification Rules	acceptance: correct packet length execution: always		
<b>Header Information</b>			
Process ID	92	Packet Category	12
Service Type	19	Service Subtype	10
Structure ID	N/A	Packet Length	2 data
<b>Data Field Information</b>			
Data Field	Field Structure	Remarks	
Pressure	real (8-special)	Rosina pressure reading (mbar)	
Pressure_Gradient	real (8-special)	Rosina pressure gradient (mbar/sec)	
<b>Notes:</b> This packet is part of the information distribution service provided by the spacecraft. Alice needs this information for its internal safety procedures. The special real format has 4-bit mantissa with range of 1-9, and 4-bit negative exponent from 0-15.			

<b>Telecommand Packet Definition (Alice)</b>			
Packet Name	ROSINA pressure alert	Instrument	Alice
Packet Function	provide ROSINA pressure alert		
Verification Rules	acceptance: correct packet length execution: always		
<b>Header Information</b>			
Process ID	92	Packet Category	12
Service Type	19	Service Subtype	11
Structure ID	N/A	Packet Length	2 data
<b>Data Field Information</b>			
Data Field	Field Structure	Remarks	
see notes	see notes	see notes	
<b>Notes:</b> This packet is identical to Rosina pressure distribution (19, 10), except that it is generated when the pressure exceeds a predefined limit (defined by Rosina). Receipt of this packet indicates that Rosina is safed and no more pressure distribution messages will be received. This packet is processed identical by Alice to the ROSINA pressure message (19,10).			



<b>Telecommand Packet Definition (Alice)</b>			
Packet Name	Giada dust monitor	Instrument	Alice
Packet Function	provide dust alert to Alice		
Verification Rules	acceptance: correct packet length execution: always		
<b>Header Information</b>			
Process ID	92	Packet Category	12
Service Type	19	Service Subtype	12
Structure ID	N/A	Packet Length	2 data
<b>Data Field Information</b>			
Data Field	Field Structure	Remarks	
DustFlux	unsigned (16)	dust flux in particles/m <sup>2</sup> /minute	
<b>Notes:</b>			
This packet provides dust information to instruments.			
EID-A says that flux saturates at a count of about 600, and that the value will read as 0xFFFF.			
Alice needs this information for its internal safety procedures.			

<b>Telecommand Packet Definition (Alice)</b>			
Packet Name	Enable/Disable Science	Instrument	Alice
Packet Function	enable/disable instrument science data output		
Verification Rules	acceptance: correct packet length, correct PID; execution: always		
<b>Header Information</b>			
Process ID	92	Packet Category	12
Service Type	20	Service Subtype	1, 2 (see notes)
Structure ID	N/A	Packet Length	2 data
<b>Data Field Information</b>			
Data Field	Field Structure	Remarks	
PID	enum (16)	process ID of science generation source; value always = 92	
<b>Notes:</b>			
Sub-type 1 enables science output, sub-type 2 disables the science output.			
This command does not have any effect on Alice operation			

<b>Telecommand Packet Definition (Alice)</b>			
Packet Name	Enter safe state	Instrument	Alice
Packet Function	cause Alice to enter the safe operating state		
Verification Rules	acceptance: always; execution: failure if state change not successful		
<b>Header Information</b>			
Process ID	92	Packet Category	12
Service Type	192	Service Subtype	1
Structure ID	N/A	Packet Length	0 data
<b>Data Field Information</b>			
Data Field	Field Structure	Remarks	
		none	
<b>Notes:</b>			

<b>Telecommand Packet Definition (Alice)</b>			
Packet Name	Enter checkout state	Instrument	Alice
Packet Function	cause Alice to enter the checkout operating state		
Verification Rules	acceptance: always; execution: failure if state change not successful		
<b>Header Information</b>			
Process ID	92	Packet Category	12
Service Type	192	Service Subtype	2
Structure ID	N/A	Packet Length	0 data
<b>Data Field Information</b>			
Data Field	Field Structure	Remarks	
		none	
<b>Notes:</b>			

<b>Telecommand Packet Definition (Alice)</b>			
Packet Name	Confirm critical	Instrument	Alice
Packet Function	confirms a previously transmitted "critical" telecommand		
Verification Rules	acceptance: correct packet length; execution: failure if no critical command pending (possible critical telecommand timeout expired)		
<b>Header Information</b>			
Process ID	92	Packet Category	12
Service Type	192	Service Subtype	3
Structure ID	N/A	Packet Length	2 data
<b>Data Field Information</b>			
Data Field	Field Structure	Remarks	
	unsigned (16 bits)	type and sub-type of pending critical telecommand	
<b>Notes:</b>			
When a critical telecommand is received, it is held pending.			
Only one critical telecommand can be pending at any time.			
This confirmation must be received within 30 seconds for a pending critical telecommand.			

<b>Telecommand Packet Definition (Alice)</b>			
Packet Name	Deleted (was Acquire histogram)	Instrument	Alice
Packet Function	none		
Verification Rules	acceptance: never		
<b>Header Information</b>			
Process ID	92	Packet Category	12
Service Type	192	Service Subtype	4
Structure ID	N/A	Packet Length	-
<b>Notes:</b>			
Telecommand deleted after addition of the Multiple Acquire Dump telecommand (192,26)			

<b>Telecommand Packet Definition (Alice)</b>			
Packet Name	Deleted (was Acquire pixel list)	Instrument	Alice
Packet Function	none		
Verification Rules	acceptance: never		
<b>Header Information</b>			
Process ID	92	Packet Category	12
Service Type	192	Service Subtype	5
Structure ID	N/A	Packet Length	-
<b>Notes:</b>			
Telecommand deleted after addition of the Multiple Acquire Dump telecommand (192,26)			

<b>Telecommand Packet Definition (Alice)</b>			
Packet Name	Deleted (was Acquire count rate)	Instrument	Alice
Packet Function	none		
Verification Rules	acceptance: never		
<b>Header Information</b>			
Process ID	92	Packet Category	12
Service Type	192	Service Subtype	6
Structure ID	N/A	Packet Length	-
<b>Notes:</b>			
Telecommand deleted after addition of the Multiple Acquire Dump telecommand (192,26)			

<b>Telecommand Packet Definition (Alice)</b>			
Packet Name	Stop acquire	Instrument	Alice
Packet Function	cause Alice to stop Multiple Acquire Dump in progress		
Verification Rules	acceptance: always; execution: always		
<b>Header Information</b>			
Process ID	92	Packet Category	12
Service Type	192	Service Subtype	7
Structure ID	N/A	Packet Length	0 data
<b>Data Field Information</b>			
Data Field	Field Structure	Remarks	
		none	
<b>Notes:</b>			
This telecommand does not have any effect when no Multiple Acquire Dump command is in progress.			

<b>Telecommand Packet Definition (Alice)</b>			
Packet Name	Deleted (was Dump science)	Instrument	Alice
Packet Function	none		
Verification Rules	acceptance: never		
<b>Header Information</b>			
Process ID	92	Packet Category	12
Service Type	192	Service Subtype	8
Structure ID	N/A	Packet Length	-
<b>Notes:</b>			
Telecommand deleted after addition of the Multiple Acquire Dump telecommand (192,26)			

<b>Telecommand Packet Definition (Alice)</b>			
Packet Name	Deleted (was Stop science dump)	Instrument	Alice
Packet Function	cause Alice to cancel a science dump already in progress		
Verification Rules	acceptance never		
<b>Header Information</b>			
Process ID	92	Packet Category	12
Service Type	192	Service Subtype	9
Structure ID	N/A	Packet Length	0 data
<b>Data Field Information</b>			
Data Field	Field Structure	Remarks	
		none	
<b>Notes:</b>			
Telecommand deleted after addition of the Multiple Acquire Dump telecommand (192,26)			

<b>Telecommand Packet Definition (Alice)</b>			
Packet Name	Clear acquisition	Instrument	Alice
Packet Function	erase the acquisition memory		
Verification Rules	acceptance always; execution always (after confirmation)		
<b>Header Information</b>			
Process ID	92	Packet Category	12
Service Type	192	Service Subtype	10
Structure ID	N/A	Packet Length	0 data
<b>Data Field Information</b>			
Data Field	Field Structure	Remarks	
		none	
<b>Notes:</b>			
-critical -clear memory command causes dump type to be reset to histogram; a dump following a clear will result in a (blank) histogram dump			

<b>Telecommand Packet Definition (Alice)</b>			
Packet Name	Set parameter	Instrument	Alice
Packet Function	sets the value of an internal parameter		
Verification Rules	acceptance: correct packet length, valid parameter ID; execution always		
<b>Header Information</b>			
Process ID	92	Packet Category	12
Service Type	192	Service Subtype	11
Structure ID	N/A	Packet Length	2 data
<b>Data Field Information</b>			
Data Field	Field Structure	Remarks	
ParmId	unsigned (8)	parameter identification (location in table, 0-39)	
ParmVal	unsigned (8)	parameter value (value of the parameter)	
<b>Notes:</b>			
For 16 bit parameters, this command must be used twice to update both 8 bit portions of the 16 bit parameter. This operation is not atomic so care must be taken to make sure that the instrument is in a reasonable mode for this type of update.			

<b>Telecommand Packet Definition (Alice)</b>			
Packet Name	Set safety mask	Instrument	Alice
Packet Function	sets the value of the safety mask		
Verification Rules	acceptance: correct safety ID;		

execution: always (after confirmation)			
<b>Header Information</b>			
Process ID	92	Packet Category	12
Service Type	192	Service Subtype	12
Structure ID	N/A	Packet Length	2 data
<b>Data Field Information</b>			
Data Field	Field Structure	Remarks	
SafetyId	enum (4) 0 = dust 1 = bright 2 = pres. trend 3 = pres. alert 4 = HVPS error 5 = over temp 6-14 unused 15 = affect all	safety condition identifier	
SafetyMasked	boolean (1)	mask state (true = masked)	
	(11)	unused	
<b>Notes:</b> critical			

<b>Telecommand Packet Definition (Alice)</b>			
Packet Name	Set safety override	Instrument	Alice
Packet Function	sets the state of the safety override		
Verification Rules	acceptance: always; execution: always (after confirmation)		
<b>Header Information</b>			
Process ID	92	Packet Category	12
Service Type	192	Service Subtype	13
Structure ID	N/A	Packet Length	2 data
<b>Data Field Information</b>			
Data Field	Field Structure	Remarks	
	(15)	unused	
SafetyOverride	boolean (1)	safety override (true = override)	
<b>Notes:</b> critical			

<b>Telecommand Packet Definition (Alice)</b>			
Packet Name	Open aperture door	Instrument	Alice
Packet Function	opens the aperture door		
Verification Rules	acceptance: must be in checkout state; execution: must still be in checkout state; so no safety condition active (after confirmation)		
<b>Header Information</b>			
Process ID	92	Packet Category	12
Service Type	192	Service Subtype	14
Structure ID	N/A	Packet Length	0 data
<b>Data Field Information</b>			
Data Field	Field Structure	Remarks	
		none	
<b>Notes:</b> -critical Since this is critical telecommand, there can be a time delay between acceptance and execution. Therefore the state is checked for acceptance, and again for execution. It is possible that the telecommand could be accepted but not executed if the state changes before execution. Furthermore, an execution success means that the door mechanism has successfully been commanded to open. It does not mean that the door opening is completed or confirmed. A door motion event packet is generated when the door moves (5,1). This should be used in combination with the housekeeping packet (3,25) to confirm the actual successful motion of the door.			

<b>Telecommand Packet Definition (Alice)</b>			
Packet Name	Close aperture door	Instrument	Alice
Packet Function	closes the aperture door		
Verification Rules	acceptance: always; execution: always		
<b>Header Information</b>			
Process ID	92	Packet Category	12
Service Type	192	Service Subtype	15
Structure ID	N/A	Packet Length	0 data
<b>Data Field Information</b>			
Data Field	Field Structure	Remarks	
		none	
<b>Notes:</b>			

<b>Telecommand Packet Definition (Alice)</b>			
Packet Name	High voltage on	Instrument	Alice
Packet Function	turns on high voltage and sets level		
Verification Rules	acceptance: must be in checkout state; execution: must still be in checkout state; so no safety condition active (after confirmation)		
<b>Header Information</b>			
Process ID	92	Packet Category	12
Service Type	192	Service Subtype	16
Structure ID	N/A	Packet Length	2 data
<b>Data Field Information</b>			
Data Field	Field Structure	Remarks	
	(8)	unused	
HvLevelSet	unsigned (8)	high voltage level (DAC units)	
<b>Notes:</b>			
-critical			
Since this is critical telecommand, there can be a time delay between acceptance and execution. Therefore the state is checked for acceptance, and again for execution. It is possible that the telecommand could be accepted but not executed if the state changes before execution.			
Furthermore, an execution success means that the HVPS has successfully been commanded to the new level. It does not mean that it has actually reached that level. Data in the housekeeping packet (3,25) should be used to confirm the actual high voltage level.			

<b>Telecommand Packet Definition (Alice)</b>			
Packet Name	High voltage off	Instrument	Alice
Packet Function	turns off high voltage		
Verification Rules	acceptance: always; execution: always		
<b>Header Information</b>			
Process ID	92	Packet Category	12
Service Type	192	Service Subtype	17
Structure ID	N/A	Packet Length	0 data
<b>Data Field Information</b>			
Data Field	Field Structure	Remarks	
		none	
<b>Notes:</b>			

<b>Telecommand Packet Definition (Alice)</b>			
Packet Name	Heater on	Instrument	Alice
Packet Function	turns on specified heater		
Verification Rules	acceptance: always; execution: always (after confirmation)		
<b>Header Information</b>			
Process ID	92	Packet Category	12
Service Type	192	Service Subtype	18
Structure ID	N/A	Packet Length	2 data
<b>Data Field Information</b>			
Data Field	Field Structure	Remarks	
	(7)	unused	
HeaterId	enum (1) 0 = grating	heater identifier	

	1 = mirror	
HeaterSet	unsigned (8)	heater set point (ADC counts)
<b>Notes:</b> critical		

<b>Telecommand Packet Definition (Alice)</b>			
Packet Name	Heater off	Instrument	Alice
Packet Function	turns off specified heater		
Verification Rules	acceptance: always; execution: always		
<b>Header Information</b>			
Process ID	92	Packet Category	12
Service Type	192	Service Subtype	19
Structure ID	N/A	Packet Length	2 data
<b>Data Field Information</b>			
Data Field	Field Structure	Remarks	
	(15)	unused	
HeaterId	enum (1) 0 = grating 1 = mirror	heater identifier	
<b>Notes:</b>			

<b>Telecommand Packet Definition (Alice)</b>			
Packet Name	Detector stimulator on	Instrument	Alice
Packet Function	turns on the detector stimulator		
Verification Rules	acceptance: always; execution: always		
<b>Header Information</b>			
Process ID	92	Packet Category	12
Service Type	192	Service Subtype	20
Structure ID	N/A	Packet Length	0 data
<b>Data Field Information</b>			
Data Field	Field Structure	Remarks	
		none	
<b>Notes:</b>			

<b>Telecommand Packet Definition (Alice)</b>			
Packet Name	Detector stimulator off	Instrument	Alice
Packet Function	turns off the detector stimulator		
Verification Rules	acceptance: always; execution: always		
<b>Header Information</b>			
Process ID	92	Packet Category	12
Service Type	192	Service Subtype	21
Structure ID	N/A	Packet Length	0 data
<b>Data Field Information</b>			
Data Field	Field Structure	Remarks	
		none	
<b>Notes:</b>			

<b>Telecommand Packet Definition (Alice)</b>			
Packet Name	Set discriminator level	Instrument	Alice
Packet Function	sets the detector discriminator level		
Verification Rules	acceptance: always; execution: always		
<b>Header Information</b>			
Process ID	92	Packet Category	12
Service Type	192	Service Subtype	22
Structure ID	N/A	Packet Length	2 data
<b>Data Field Information</b>			
Data Field	Field Structure	Remarks	
	(8)	unused	
DiscLevelSet	unsigned (8)	discriminator level (DAC counts)	
<b>Notes:</b>			

<b>Telecommand Packet Definition (Alice)</b>			
Packet Name	Self test	Instrument	Alice
Packet Function	runs the instrument self test		
Verification Rules	acceptance: must be in checkout state; execution: always (after confirmation: see notes)		
<b>Header Information</b>			
Process ID	92	Packet Category	12
Service Type	192	Service Subtype	23
Structure ID	N/A	Packet Length	0 data
<b>Data Field Information</b>			
Data Field	Field Structure	Remarks	
		none	
<b>Notes:</b>			
-critical			
Execution of this command initially sets the result byte (Hk Test Status, see TM(3,25)) to 0xff (no tests completed successfully). The test specification byte (Pm Test Mask) specifies which tests are to be executed (see specification in power on event package (5,1), 1 indicates selected). Next the selected tests are sequentially executed starting with the test specified by the least significant bit. When a test is completed successfully the corresponding bit in the result byte is cleared. This continues until all selected tests have been completed. Completion of all self test functions takes a total of about 20 seconds.			

<b>Telecommand Packet Definition (Alice)</b>			
Packet Name	Start program	Instrument	Alice
Packet Function	starts execution of a new memory configuration		
Verification Rules	acceptance: correct packet length and checkout state execution: always (after confirmation, see notes)		
<b>Header Information</b>			
Process ID	92	Packet Category	12
Service Type	192	Service Subtype	24
Structure ID	N/A	Packet Length	4 data
<b>Data Field Information</b>			
Data Field	Field Structure	Remarks	
	(8)	unused	
MemConfig	unsigned (8)	new value for memory configuration (see notes)	
StartAddr	unsigned (16)	new address for program execution	
<b>Notes:</b>			
-critical			
Memory configuration definition is per the memory control register (0x00 – PROM, 0x40 – EEPROM0, 0x41 – EEPROM1, 0x42 – EEPROM2, 0x43 – EEPROM3 and 0x43 – EEPROM3). Telecommand loads new configuration value into EEPROM map register, then begins executing at the specified address. Unless the started code eventually executes a proper return from subroutine possible requested the execution acknowledge is lost (it will only be generated after the (sub) routine completes).			

Telecommand Packet Definition (Alice)			
Packet Name	Get parameter file	Instrument	Alice
Packet Function	causes dump of instrument parameter file (20,3,SID=5)		
Verification Rules	acceptance: always; execution: always		
Header Information			
Process ID	92	Packet Category	12
Service Type	192	Service Subtype	25
Structure ID	N/A	Packet Length	0 data
Data Field Information			
Data Field	Field Structure	Remarks	
<b>Notes:</b> Contents of parameter file will be dumped as science packet (20,3,SID=5). Executes in the slow thread.			

Telecommand Packet Definition (Alice)			
Packet Name	Multiple Acquire Dump	Instrument	Alice
Packet Function	specifies Alice data acquisition and dump cycle		
Verification Rules	acceptance: correct telecommand length, current state is safe, hold or checkout and correct dump specification for all used slots; execution: always (after confirmation), but failure will be reported when the command execution is terminated due to a dump error or an Stop Acquire TC(192,7)		
Header Information			
Process ID	92	Packet Category	12
Service Type	192	Service Subtype	26
Structure ID	N/A	Packet Length	88 data
Data Field Information			
Data Field	Field Structure	Remarks	
	(6)	unused	
AcquisitionMode	enum (2) 0 = histogram mode 1 = pixel list (time lim.) 2 = pixel list (count lim.) 3 = count rate	Meaning of fields: AcqDuration, MarkInterval, DumpSpecifications are dependent on the selected AcquisitionMode	
	(4)	unused	
ApDoorOpen	boolean (1)	aperture door open	
DetStimOn	boolean (1)	stimulator on	
AcqMemoryClear	boolean (1)	memory clear	
GenTestPattern	boolean (1)	if true, then a test pattern is generated, instead of a real acquisition	
AcqDuration	unsigned (16)	acquisition time (seconds) (for modes 0 and 1) <sup>1)</sup> total event counts (for modes 2 and 3)	
MarkInterval	unsigned (8 bits)	unused (for mode 0) time mark interval (for modes 1 and 2, format per TC insert mask register, see h/w spec) acquisition interval (for mode 3) <sup>3)</sup> in units of 3 ms	
Repeat	unsigned (8)	number of cycle repetitions (new in version 2.05 a value of 255 defines an 'endless' cycle repeat, so the acquisition continues till explicitly commanded to stop)	
CycleTime	unsigned (16)	overall time in seconds between successive cycle starts <sup>2)</sup>	
8 dump specifications <sup>4)</sup>	WinLowSpectral	unsigned (16)	spectral window lower (inclusive) (0-1023)
	WinHighSpectral	unsigned (16)	spectral window upper (inclusive), (0-1023)
	CollapseSpectral	unsigned (16)	spectral collapse factor (1-1024)
	WinLowSpatial	unsigned (8)	spatial window lower, (0-31)
	WinHighSpatial	unsigned (8)	spatial window upper, (0-31)
	CollapseSpatial	unsigned (8)	spatial collapse factor (1-32), value of zero indicates an unused dump specification slot
	DumpDelay	unsigned (8)	delay between generation of dump TM packets in kernel ticks (0-255; 0=no delay), can be used to reduce Alice science data production rate
<b>Notes:</b> -critical -executes in the slow thread -if test pattern is specified, then the acquisition will be executed normally, but Alice acquisition memory will be filled with a test pattern after completion of the acquisition			



- 1) The time specified for the acquisition mode 1 is the maximum acquisition time, the actual time may be shorter when the acquisition memory is filled before the acquisition time is exceeded.
- 2) The time mark (hack) interval for the Pixel List acquisition (modes 1 and 2) is specified with values 0-7, which correspond to intervals of 1/256, 1/128, 1/64, 1/32, 1/16, 1/8, 1/4, and 1/2 second, respectively. I.e., the time interval is of the form  $1/2^x$  seconds, where  $x = 8 -$  the parameter value.
- 3) Cycle time specifies the overall cycle duration in seconds, start of a data acquisition will only start at the specified start time for the cycles, if a previous cycle has not been completed yet acquisition will remain idle until the next cycle start, cycle time of zero specifies continuous acquire dump operation in which cycle time is determined by the duration of acquire and dump operations (without any additional delays).
- 4) The acquisition interval for the CountRate acquisition mode is specified using a one byte number that specifies the time in units of 3 ms. The duration in milliseconds is calculated from the byte value (BV) as:  $3 * (BV \text{ mod } 32) * 2^{(BV \text{ div } 32)}$ . This exponent and mantissa like use of the specification value results in a dynamic range of 1 to 3968 (3 ms to 11.9 s) with a good resolution at the low end.
- 5) Up to 8 dump specifications can be used that will be executed in sequence, unused dump specification slots are indicated by setting the CollapseSpatial specification to zero  
 Not all parameters used in a dump specification are applicable for all acquisition modes;
 

histogram acquisition mode	all parameters are applicable, the collapse factors specify the number of pixels summed together in the spatial respective spectral dimension and should specify an integer factor of the corresponding window size.
pixel list acquisitions modes	only window specifications are applicable
count rate mode	no window or collapse can be specified

 In each case the Collapse spatial field is used to indicate a used dump specification, for the pixel list and count rate modes this means that this field should be set to a non-zero value.

Telecommand Packet Definition (Alice)			
Packet Name	Reset Telemetry Output Buffer	Instrument	Alice
Packet Function	requests instrument reset telemetry output hardware and software		
Verification Rules	acceptance: always; execution: always		
Header Information			
Process ID	92	Packet Category	12
Service Type	255	Service Subtype	1
Structure ID	N/A	Packet Length	0 data
Data Field Information			
Data Field	Field Structure	Remarks	
		none	
<b>Notes:</b>			

## 6.2 Telemetry Packet and Parameter Definitions

Telemetry Packet Definition (Alice)			
Packet Name	Telecommand Acceptance Success	Instrument	Alice
Packet Function	acknowledge successful acceptance of telecommand packet		
Generation Rules	on acceptance of telecommand with "acceptance acknowledge" header bit set		
Header Information			
Process ID	92	Packet Category	1
Service Type	1	Service Subtype	1
Structure ID	N/A	Packet Length	4 data
Data Field Information			
Data Field	Field Structure	Remarks	
TcPacketId	unsigned (16)	Packet ID field from telecommand	
TcSequence	unsigned (16)	Packet sequence field from telecommand	
<b>Notes:</b>			

Telemetry Packet Definition (Alice)			
Packet Name	Telecommand Acceptance Failure	Instrument	Alice
Packet Function	indicate acceptance failure of telecommand packet		
Generation Rules	on rejection of telecommand with "acceptance acknowledge" header bit set		
Header Information			

Process ID	92	Packet Category	1
Service Type	1	Service Subtype	2
Structure ID	N/A	Packet Length	8 or 12 data
<b>Data Field Information</b>			
Data Field	Field Structure	Remarks	
TcPacketId	unsigned (16)	Packet ID field from telecommand	
TcSequence	unsigned (16)	Packet sequence field from telecommand	
FailureCode	enum (16) (see notes)	defined per EID-A 2.8.3.1.4	
Parm1	unsigned (8)	Packet type field from telecommand	
Parm2	unsigned (8)	Packet sub-type field from telecommand	
Parm3	unsigned (16)	depends on failure code (see notes)	
Parm4	unsigned (16)	depends on failure code (see notes)	
<b>Notes:</b> values for FailureCode and Parm3 and Parm4 shown below			
FailureCode	Parm3	Parm4	
1 - TC packet timeout	bytes indicated in TC packet header	bytes actually received	
2 - check sum error	checksum indicated in telecommand packet	computed checksum for telecommand	
3 - APID error	not present	not present	
4 - invalid command code	0	0	
5 - status error	instrument state (lower 3 bits)	0	
6 - data field error	word position of bad data field	value of bad data field	

<b>Telemetry Packet Definition (Alice)</b>			
Packet Name	Telecommand Execution Success	Instrument	Alice
Packet Function	acknowledge successful execution of telecommand		
Generation Rules	successful completion of execution of telecommand with "execution acknowledge" header bit set		
<b>Header Information</b>			
Process ID	92	Packet Category	1
Service Type	1	Service Subtype	7
Structure ID	N/A	Packet Length	4 data
<b>Data Field Information</b>			
Data Field	Field Structure	Remarks	
TcPacketId	unsigned (16)	Packet ID field from telecommand	
TcSequence	unsigned (16)	Packet sequence field from telecommand	
<b>Notes:</b>			

<b>Telemetry Packet Definition (Alice)</b>			
Packet Name	Telecommand Execution Failure	Instrument	Alice
Packet Function	indicate execution failure of telecommand		
Generation Rules	erroneous completion of execution of telecommand with "execution acknowledge" header bit set		
<b>Header Information</b>			
Process ID	92	Packet Category	1
Service Type	1	Service Subtype	8
Structure ID	N/A	Packet Length	8 data
<b>Data Field Information</b>			
Data Field	Field Structure	Remarks	
TcPacketId	unsigned (16)	Packet ID field from telecommand	
TcSequence	unsigned (16)	Packet sequence field from telecommand	
FailureCode	enum (16) (see notes)	defined per EID-A 2.8.3.1.4	
Parm1	unsigned (8)	Packet type field from telecommand	
Parm2	unsigned (8)	Packet sub-type field from telecommand	
<b>Notes:</b> values for FailureCode 1 - execution error			

<b>Telemetry Packet Definition (Alice)</b>			
Packet Name	Housekeeping	Instrument	Alice
Packet Function	Provide Alice routine housekeeping data		
Generation Rules	Periodic when enabled, default rate is 30 seconds (configurable by parameter).		
<b>Header Information</b>			
Process ID	92	Packet Category	4
Service Type	3	Service Subtype	25
Structure ID	1	Packet Length	46 data

Data Field Information		
Data Field	Field Structure	Remarks
SID	enum (16)	value = 1
HkHvOn	enum (1) 0 = off 1 = on	high voltage arm indication, from sensor (most significant bit of 8 bits bit-field)
HkDetStim	enum (1) 0 = stim off 1 = stim on	detector stimulator indication
HkAcqCountRate	boolean (1)	count rate acquisition mode (true = count rate mode; if true then HkAcqMode below is don't care)
HkAcqMode	enum (1) 0 = pixel list 1 = histogram	hardware acquisition mode
HkAcqActive	enum (1) 0 = not active 1 = active	acquisition hardware active
HkDetDoor	enum (1) 0 = open 1 = closed	indicates detector door position, from sensor
HkApDoor	enum (2) 0 = error 1 = closed 2 = open 3 = in between	indicates aperture door position, from sensor (least significant bits of bit field)
EEPromCode	enum (1) 0 = PROM code 1 = EEPROM code	currently executing code
HkState	enum (3) 0 = checkout 1 = acquire 2 = dump 3 = safe 4 = hold 5 = safedump 6, 7 = unused	operating state
EEPromPage	enum (2) 0 = Page 0 1 = Page 1 2 = Page 2 3 = Page 3	Current active EEPROM page when executing EEPROM code, see also EEPromCode status bit
HkMirrorHtrOn	boolean (1)	indicates mirror heater power
HkGratingHtrOn	boolean (1)	indicates grating heater power
HkCountRate	unsigned (16)	instantaneous detector count rate units are detector counts/PmCounterInterval
HkCountRateLo	unsigned (16)	stored minimum detector count rate since last report
HkCountRateHi	unsigned (16)	stored maximum detector count rate since last report
HkHvSet	unsigned (8)	high voltage set point (DAC counts)
HkMcpV	unsigned (8)	instantaneous MCP voltage (ADC counts)
HkMcpVlo	unsigned (8)	stored MCP minimum voltage since last report
HkMcpVhi	unsigned (8)	stored MCP maximum voltage since last report
HkAnodeV	unsigned (8)	instantaneous anode voltage (ADC counts)
HkAnodeVlo	unsigned (8)	stored anode minimum voltage since last report
HkAnodeVhi	unsigned (8)	stored anode maximum voltage since last report
HkStripI	unsigned (8)	instantaneous strip current (ADC counts)
HkStripIlo	unsigned (8)	stored minimum strip current since last report
HkStripIhi	unsigned (8)	stored maximum strip current since last report
HkMirrorTempPri	unsigned (8)	mirror primary temperature sensor (ADC counts)
HkMirrorTempSec	unsigned (8)	mirror secondary temperature sensor
HkMirrorHtrSet	unsigned (8)	mirror heater temperature set point (ADC counts)
HkGratingTempPri	unsigned (8)	grating primary temperature sensor
HkGratingTempSec	unsigned (8)	grating secondary temperature sensor
HkGratingHtrSet	unsigned (8)	grating heater temperature set point
HkDetDiscr	unsigned (8)	detector discriminator level (ADC counts)
HkCyclesRemaining	unsigned (8)	number of remaining cycles in current Multiple Acquire Dump command
HkLastPressure	real (8-special)	last pressure reading from Rosina
HkLastPrsRate	real (8-special)	last pressure rate from Rosina

HkPressureTime	time (48)	time of last rosina pressure reading
HkUnsafeTimer	unsigned (16)	unsafe timer (seconds)
HkSafetyDust	boolean (1)	safety condition - dust (true = safety in effect)
HkSafetyBright	boolean (1)	safety condition - bright object
HkSafetyTrend	boolean (1)	safety condition - pressure trend
HkSafetyAlert	boolean (1)	safety condition - pressure alert
HkSafetyHvps	boolean (1)	safety condition - high voltage
HkSafetyTemp	boolean (1)	safety condition - temperature
HkSafetyOverride	boolean (1)	safety override
	boolean (1)	unused
HkSafetyMask	bool (1) dust alert bool (1) bright bool (1) pres trend bool (1) pres alert bool (1) HVPS bool (1) temp. (2) spare	safety mask bits (true = condition masked)
HkDetElecTemp	unsigned (8)	detector electronics temperature (ADC counts)
HkDetHousingTemp	unsigned (8)	detector housing temperature
HkCdhElecTemp	unsigned (8)	C&DH electronics temperature
HkInstrHousingTemp	unsigned (8)	instrument housing temperature
HkTestStatus	bool (1) rtx clock bool (1) fine clock bool (1) RAM memory bool (1) acq. page switch bool (1) acq. memory 3 bool (1) acq. memory 2 bool (1) acq. memory 1 bool (1) acq. memory 0	self test results (set to 0xff at start of Self Test command (192,23), 0 = test completed successfully), value only valid after completion of the Self Test
HkAfsVersion	unsigned (4) major version unsigned (4) minor version	software version
<p><b>Notes:</b>          Packet production rate is determined by a parameter in the <i>Alice</i> software parameter file. The default rate is one packet per 30 seconds. The rate can be changed by private telecommand for exceptional situations (troubleshooting).          Whenever this packet is generated all data fields are filled in with the most recent measured values or state information, the only exception being the field HkTestStatus that is only updated when a test is commanded using the 'Perform Self test' command, initially this field will show the value 0x10.</p>		

<b>Telemetry Packet Definition (<i>Alice</i>)</b>			
Packet Name	Aperture door motion event	Instrument	<i>Alice</i>
Packet Function	Indicate aperture door motion (severity - normal)		
Generation Rules	when aperture door position changes		
<b>Header Information</b>			
Process ID	92	Packet Category	7
Service Type	5	Service Subtype	1
Structure ID	40001 (event ID)	Packet Length	4 data
<b>Data Field Information</b>			
Data Field	Field Structure	Remarks	
EID	enum (16)	value = 40001	
	(14)	unused	
EvDoorPos	enum (2) 0 = error 1 = closed 2 = opened 3 = in between	door position	
<b>Notes:</b>			

<b>Telemetry Packet Definition (Alice)</b>				
Packet Name	Aperture door motion error event		Instrument	Alice
Packet Function	Indicate aperture door motion error (severity - warning)			
Generation Rules	when door does not move as expected			
<b>Header Information</b>				
Process ID	92	Packet Category	7	
Service Type	5	Service Subtype	2	
Structure ID	40002	Packet Length	4 data	
<b>Data Field Information</b>				
Data Field	Field Structure	Remarks		
EID	enum (16)	value = 40002		
	(6)	unused		
EvDoorSet	enum (2) 1 = closed 2 = open	expected door position		
	(6)	unused		
EvDoorPos	enum (2) 0 = error 1 = closed 2 = opened 3 = in between	actual door position		
<b>Notes:</b>				

<b>Telemetry Packet Definition (Alice)</b>				
Packet Name	High voltage change event		Instrument	Alice
Packet Function	Indicate instrument high voltage changed (severity - normal)			
Generation Rules	when high voltage set point changes			
<b>Header Information</b>				
Process ID	92	Packet Category	7	
Service Type	5	Service Subtype	1	
Structure ID	40003	Packet Length	4 data	
<b>Data Field Information</b>				
Data Field	Field Structure	Remarks		
EID	enum (16)	value = 40003		
EvHvSet	unsigned (8)	high voltage set level (DAC units)		
	(7)	unused		
EvHvOn	boolean (1)	high voltage on (1=on)		
<b>Notes:</b>				
This event is generated whenever the internal setpoint for the high voltage is changed. It does not reflect actual high voltage, only the set point. The HVPS can be commanded to a set point of 0 (and be on) so the HvOn bit indicates if the supply is commanded on or off, in addition to the set point.				

<b>Telemetry Packet Definition (Alice)</b>				
Packet Name	Parameter read warning event		Instrument	Alice
Packet Function	Indicate error reading internal parameter (severity - warning)			
Generation Rules	when one of three parameter readings does not agree			
<b>Header Information</b>				
Process ID	92	Packet Category	7	
Service Type	5	Service Subtype	2	
Structure ID	40004	Packet Length	8 data	
<b>Data Field Information</b>				
Data Field	Field Structure	Remarks		
EID	enum (16)	value = 40004		
	(8)	unused		
EvParmId	unsigned (8 bits)	parameter identifier		
	(6)	unused		
EvParmTable	unsigned (2 bits)	table identifier (0-2)		
EvParmVal0	unsigned (8 bits)	table 0 parameter value		
EvParmVal1	unsigned (8 bits)	table 1 parameter value		
EvParmVal2	unsigned (8 bits)	table 2 parameter value		
<b>Notes:</b>				

<b>Telemetry Packet Definition (Alice)</b>			
Packet Name	Parameter read error event	Instrument	Alice
Packet Function	Indicate error reading internal parameter (severity - on-board)		
Generation Rules	when none of three parameter readings agree		
<b>Header Information</b>			
Process ID	92	Packet Category	7
Service Type	5	Service Subtype	4
Structure ID	40005	Packet Length	6 data
<b>Data Field Information</b>			
Data Field	Field Structure	Remarks	
EID	enum (16)	value = 40005	
EvParmId	unsigned (8 bits)	parameter identifier	
EvParmVal0	unsigned (8 bits)	table 0 parameter value	
EvParmVal1	unsigned (8 bits)	table 1 parameter value	
EvParmVal2	unsigned (8 bits)	table 2 parameter value	
<b>Notes:</b>			

<b>Telemetry Packet Definition (Alice)</b>			
Packet Name	Safety event	Instrument	Alice
Packet Function	indicate safety condition occurred (severity - ground, on-board; see notes)		
Generation Rules	when unmasked, non-overridden safety condition occurs		
<b>Header Information</b>			
Process ID	92	Packet Category	7
Service Type	5	Service Subtype	3, 4 (notes)
Structure ID	40006	Packet Length	6 data
<b>Data Field Information</b>			
Data Field	Field Structure	Remarks	
EID	enum (16)	value = 40006	
	(8)	unused	
EvSafetyId	enum (4) 0 = dust alert 1 = bright object 2 = pres. trend 3 = pres. alert 4 = HVPS error 5 = over temp. 6-15 = not used	safety condition identifier	
EvSafetySubId	enum (4)	sub-identifier, depends on value of EvSafetyID above; for temperature safety, this field contains the ADC channel of the temperature sensor causing the safety; for HVPS safety, this field identifies which HVPS check caused the error as follows: 0 = anode voltage limits 1 = strip current limits 2 = MCP tolerance error	
EvSafetyValue	unsigned (16 bits)	safety condition value, depends on value of EvSafetyId; dust – dust flux value bright - detector count rate pres. trend – pressure rate pres. alert - triggering pressure HVPS - value of erroneous check (low 8 bits) and current McpSetpoint (upper 8 bits) temperature - ADC temperature value	
<b>Notes:</b>			
The severity is configurable by parameter PmEventSafety and is either ground (sub-type 3), or on-board (sub-type 4). This packet is only generated each time the safety status changes to a “less safe” condition – whenever a new condition is triggered. If multiple conditions occur at the same time then only one is indicated.			

<b>Telemetry Packet Definition (Alice)</b>			
Packet Name	Power-on event	Instrument	Alice
Packet Function	indicate instrument turn-on or reset (severity – normal)		
Generation Rules	generated about 20 seconds after instrument turn-on or reset		
<b>Header Information</b>			
Process ID	92	Packet Category	7
Service Type	5	Service Subtype	1

Structure ID	40007	Packet Length	4 data
<b>Data Field Information</b>			
Data Field	Field Structure	Remarks	
EID	enum (16)	value = 40007	
EvCodeCheck	unsigned (8)	simple checksum calculated during startup of code memory	
EvStartupInfo	bool (1) rtx clock bool (1) fine clock bool (1) RAM memory bool (1) acq. page switch bool (1) acq. memory 3 bool (1) acq. memory 2 bool (1) acq. memory 1 bool (1) acq. memory 0	test results of the power on self test (1 = test failed), tests identical to the test executed in response to the Self Test command (192,23)	
<b>Notes:</b> Generated when <i>Alice</i> is turned on, or if <i>Alice</i> resets (such as a watchdog timeout). The Info field contains information about the startup, such as a self-test report. Note that since this packet is produced automatically when <i>Alice</i> is started, the packet time field will generally contain unsynchronized time.			

<b>Telemetry Packet Definition (Alice)</b>			
Packet Name	Acquisition event	Instrument	<i>Alice</i>
Packet Function	indicate progress of the Multiple Acquire Dump cycle (severity normal/warning <sup>1)</sup> )		
Generation Rules	generated at start of Multiple Acquire Dump command cycle		
<b>Header Information</b>			
Process ID	92	Packet Category	7
Service Type	5	Service Subtype	1/2 <sup>1)</sup>
Structure ID	40008	Packet Length	8 data
<b>Data Field Information</b>			
Data Field	Field Structure	Remarks	
EID	enum (16)	value = 40008	
	(6)	unused	
ProgressId	enum (2) 0 = not used 1 = start cycle (acquisition) 2 = safety active 3 = start missed	progress identifier	
Cycle	unsigned (8)	current cycle within the MAD command (0 to TotalCycles-1)	
TotalCycles	unsigned (8)	total number of cycles requested in the MAD command	
SafetyStatus	(7) safety status (1) spare	copy of current safety conditions (7 separate safety flags), for definition see HkSafety definition in Housekeeping TM package	
SafetyTimeout	unsigned (16 bits)	copy of current value of the unsafe timer	
<b>Notes:</b> This packet is only generated each time within the execution of a MultipleAcquireDump command when the cycle reaches the point where it is ready to start a data acquisition. It indicates the progress of the command and reports if the actual acquisition has been started. 1) subtype 1 is used for the normal start of a cycle events, subtype 2 is used as a warning for safety active and start missed events.			

<b>Telemetry Packet Definition (Alice)</b>			
Packet Name	Memory Dump	Instrument	<i>Alice</i>
Packet Function	dump instrument memory		
Generation Rules	when solicited by dump memory TC (6,5)		
<b>Header Information</b>			
Process ID	92	Packet Category	9
Service Type	6	Service Subtype	6
Structure ID	N/A	Packet Length	8+1024 max
<b>Data Field Information</b>			
Data Field	Field Structure	Remarks	
MemoryId	enum (8) (see notes)	identifies memory type of dump	
Blocks	unsigned (8)	number of memory blocks in packet, <b>always 1 for Alice</b>	
MemStart	unsigned (32)	memory starting address of this block (word address)	
MemLength	unsigned (16)	number of words in block	
MemData	unsigned (16) * MemLength	memory data, must always be even number of bytes; this field is repeated for the number of words specified by MemLength	
<b>Notes:</b>			

Maximum dump words per packet is 512 (1024 octets). A single dump can be spread over multiple packets. The following table shows the memory ID types for *Alice*.

MemoryId (note decimal number)	Description	Width (bits)	Address range (hex)
40	Code Memory (read-only)	16	00000000-00007FFF
41	EEPROM (r/w)	16	00000000-0000FFFF
42	Detector (r/w)	16	00000000-00007FFF
43	Data Memory (r/w)	16	00000000-00007FFF

**Telemetry Packet Definition (*Alice*)**

Packet Name	Memory Check	Instrument	<i>Alice</i>
Packet Function	produce memory checksum		
Generation Rules	when solicited by check memory TC (6,9)		
<b>Header Information</b>			
Process ID	92	Packet Category	7
Service Type	6	Service Subtype	10
Structure ID	N/A	Packet Length	10 data
<b>Data Field Information</b>			
Data Field	Field Structure	Remarks	
MemoryId	enum (8) (see notes)	identifies memory type of check	
Blocks	unsigned (8)	number of memory block checksums, <b>always 1</b>	
MemStart	unsigned (32)	memory starting address of this block (word address)	
MemLength	unsigned (16)	number of words in block	
MemCheck	unsigned (16)	checksum of memory block (see notes)	
<b>Notes:</b>			
-the memory types (MemoryId field) is the same as the memory dump packet (6,6)			
-the checksum method is 8 bit XOR-rotate			

**Telemetry Packet Definition (*Alice*)**

Packet Name	Connection Test Report	Instrument	<i>Alice</i>
Packet Function	report connection test		
Generation Rules	when solicited by connection test TC (17,1)		
<b>Header Information</b>			
Process ID	92	Packet Category	7
Service Type	17	Service Subtype	2
Structure ID	N/A	Packet Length	0 data
<b>Data Field Information</b>			
Data Field	Field Structure	Remarks	
this packet has no application data fields			
<b>Notes:</b>			

**Telemetry Packet Definition (*Alice*)**

Packet Name	Context report	Instrument	<i>Alice</i>
Packet Function	provide <i>Alice</i> context report		
Generation Rules	when solicited by report context TC (18,1)		
<b>Header Information</b>			
Process ID	92	Packet Category	11
Service Type	18	Service Subtype	2
Structure ID	N/A	Packet Length	42
<b>Data Field Information</b>			
Data Field	Field Structure	Remarks	
[0] PmHtrSenseGrating	unsigned (8)	grating heater sensor select; 0=primary, 1=secondary	
[1] PmHtrSenseMirror	unsigned (8)	mirror heater sensor select; 0=primary, 1=secondary	
[2] PmDoorEnable	unsigned (8)	enable door close on safety (non-0 = close on safety)	
[3] PmDacAdcFactor	unsigned (8)	conversion from Adc readback to Dac setting used in HVPS checking	
[4] PmEventSafety	unsigned (8)	safety event severity selection; 0=ground, 1=on-board	
[5] PmDiscriminator	unsigned (8)	discriminator set level (units, DAC counts)	
[6] PmHotSeg1	special (8)	hot segment 1	
[7] PmHotSeg2	special (8)	hot segment 2	
[8] PmHotSeg3	special (8)	hot segment 3	
[9] PmHotSeg4	special (8)	hot segment 4	
[10] PmHotSeg5	special (8)	hot segment 5	



[11] PmHotSeg6	special (8)	hot segment 6
[12] PmHotSeg7	special (8)	hot segment 7
[13] PmHotSeg8	special (8)	hot segment 8
[14] PmHvLevel	unsigned (8)	high voltage operating level (units, DAC counts)
[15] PmHvStepSize	unsigned (8)	high voltage step size (units, DAC counts)
[16] PmHvRunTime	unsigned (8)	high voltage processing run period (units, kernel clock ticks)
[17] PmHvMaxStripI	unsigned (8)	maximum allowed strip current (ADC counts)
[18] PmHvMinAnodeV	unsigned (8)	minimum allowed anode voltage (ADC counts)
[19] PmHvMaxAnodeV	unsigned (8)	maximum allowed anode voltage (ADC counts)
[20] PmHvMcpTol	unsigned (8)	MCP voltage tolerance (units, ADC counts)
[21] PmHvFailAnode	unsigned (8)	anode voltage max fail count
[22] PmHvFailMcp	unsigned (8)	MCP voltage max fail count
[23] PmHvFailStrip	unsigned (8)	strip current max fail count
[24] PmDoorTimeout	unsigned (8)	aperture door motion timeout (kernel clock ticks), top bit disables door position sensing, updated when door is commanded
[25] PmCounterInterval	unsigned (8)	detector event counter read rate (in kernel ticks)
[26] PmCountSlots	unsigned (8)	number of count rate "slots" for histogram acquisitions
[27] PmMaxPressure	real (8-special)	maximum allowed pressure (units, ROSINA 8 bit real)
[28] PmPressTimeMargin	unsigned (8)	pressure trend time margin (seconds * 10)
[29] PmMaxTemp	unsigned (8)	maximum allowed temperature (ADC counts)
[30] PmTempMask	grating 1 (1) grating 2 (1) mirror 1 (1) mirror 2 (1) detector body (1) chassis (1) detector electronics (1) C&DH electronics (1)	temperature sensor mask (1=enabled, 0=masked)
[31] PmHtrTolGrating	unsigned (8)	grating heater temperature tolerance (ADC counts)
[32] PmHtrTolMirror	unsigned (8)	mirror heater temperature tolerance
[33] PmTestMask	unsigned (8)	self-test mask (1 = selected), see description of SelfTest TC(192,23)
[34] PmHkRate	unsigned (8)	housekeeping production rate (seconds)
[35] PmDiagEnable	unsigned (8)	diagnostic data production enabled if non-zero
[36] PmMaxCountRate	unsigned (16)	maximum allowed count rate (counts/PmCounterInterval)
[38] PmSafetyTimeout	unsigned (16)	safety timeout (seconds)
[40] PmMaxDust	unsigned (16)	dust flux safety limit
<b>Notes:</b> Each hot segment specification masks out detector events in a rectangular area (32 spectral * 4 spatial pixels), top three bits specify the spatial position of this window, remaining 5 bits specify the spectral position of the window.		

<b>Telemetry Packet Definition (Alice)</b>			
Packet Name	Science histogram	Instrument	Alice
Packet Function	provide histogram mode science data		
Generation Rules	receipt of Multiple Acquire Dump telecommand (192, 26) when specified dump is executed and histogram mode data available, one dump can consist of up to 19 TM packets		
<b>Header Information</b>			
Process ID	92	Packet Category	12
Service Type	20	Service Subtype	3
Structure ID	1	Packet Length	3994 max data
<b>Data Field Information</b>			
Data Field	Field Structure	Remarks	
SID	enum (16)	value = 1	
McpMaxV	unsigned (8)	MCP high level during acquisition (ADC counts)	
McpMinV	unsigned (8)	MCP low level during acquisition (ADC counts)	
McpStartV	unsigned (8)	MCP level at start of acquisition (ADC counts)	
McpStopV	unsigned (8)	MCP level at stop of acquisition (ADC counts)	
StripMaxI	unsigned (8)	strip current high level during acquisition (ADC counts)	
StripMinI	unsigned (8)	strip current low level during acquisition (ADC counts)	
StripStartI	unsigned (8)	strip current at start of acquisition (ADC counts)	
StripStopI	unsigned (8)	strip current at stop of acquisition (ADC counts)	
HkData	unsigned (8) * 44	housekeeping data (see notes)	
ParmData	unsigned (8) * 42	configuration data/context (see notes)	
PressMax	real (8-special)	high ROSINA pressure reported during acquisition, minimum value if no ROSINA pressure reported during acquisition	
PressMin	real (8-special)	low ROSINA pressure reported during acquisition, maximum value if	

		no ROSINA pressure reported during acquisition
StartTime	time (48)	acquisition start time
StopTime	time (48)	actual stop time
DumpNo	unsigned (3)	dump specification number producing this dump (0-7)
SciSeq	unsigned (5)	sequence number in this dump (0-18)
DetectorCounts	unsigned (24)	total counts from detector event counter (114 bytes to here)
PhdData	unsigned (16 bits) X 16	pulse height data, 16 items
CountRateInterval	unsigned (8)	count rate data recording interval (kernel ticks)
CountRateItems	unsigned (8)	number of count rate items actually listed in CountRateData
CountRateData	unsigned (16) * 100	list of count rate items (100 slots, even if less counts available)
AcqTime	unsigned (16)	commanded integration time (seconds)
WinLowSpectral	unsigned (16)	spectral window lower (inclusive), 0-1023
WinHighSpectral	unsigned (16)	spectral window upper (inclusive), 0-1023
CollapseSpectral	unsigned (16)	spectral collapse factor (1-1024)
WinLowSpatial	unsigned (8)	spatial window lower, 0-31
WinHighSpatial	unsigned (8)	spatial window upper, 0-31
CollapseSpatial	unsigned (8)	spatial collapse factor (1-32)
	(8)	unused
PixelItems	unsigned (16)	count of pixels in packet
StartPixel	unsigned (16)	start pixel number in packet
PixelData	unsigned (16 bits) X N	list of N pixels (max N = 3994-364 = 3630 octets → 1815 words)
<b>Notes:</b>		
-Housekeeping data item is the same as data field of housekeeping data telemetry packet, not including SID.		
-Parameter data item is the same as data field of context telemetry packet (18,2)		
-Total packet length is variable depending on quantity of science data. (estimated overhead 364 octets, remainder is pixel list; up to 3630 octets/1815 pixels)		
-All of the packet fields from the beginning to the DetectorCounts field (inclusive) are common to all science data packets.		
-CountRateData field always has 100 slots for count rate data. The actual number of items in the list may vary and is indicated by the CountRateItems field. Any unused slots in CountRateData will have undefined values.		

<b>Telemetry Packet Definition (Alice)</b>			
Packet Name	Science pixel	Instrument	Alice
Packet Function	provide pixel mode science data		
Generation Rules	receipt of Multiple Acquire Dump telecommand (192,26) when specified dump is executed and pixel mode data available, one dump can consist of up to 17 TM packets		
<b>Header Information</b>			
Process ID	92	Packet Category	12
Service Type	20	Service Subtype	3
Structure ID	0	Packet Length	3994 max data
<b>Data Field Information</b>			
Data Field	Field Structure	Remarks	
SID	enum (16)	value = 0	
McpMaxV	unsigned (8)	MCP high level during acquisition (ADC counts)	
McpMinV	unsigned (8)	MCP low level during acquisition (ADC counts)	
McpStartV	unsigned (8)	MCP level at start of acquisition (ADC counts)	
McpStopV	unsigned (8)	MCP level at stop of acquisition (ADC counts)	
StripMaxI	unsigned (8)	strip current high level during acquisition (ADC counts)	
StripMinI	unsigned (8)	strip current low level during acquisition (ADC counts)	
StripStartI	unsigned (8)	strip current at start of acquisition (ADC counts)	
StripStopI	unsigned (8)	strip current at stop of acquisition (ADC counts)	
HkData	unsigned (8) * 44	housekeeping data (see notes)	
ParmData	unsigned (8) * 42	configuration data/context (see notes)	
PressMax	real (8-special)	high ROSINA pressure reported during acquisition, minimum value if no ROSINA pressure reported during acquisition	
PressMin	real (8-special)	low ROSINA pressure reported during acquisition, maximum value if no ROSINA pressure reported during acquisition	
StartTime	time (48)	acquisition start time	
StopTime	time (48)	actual stop time	
DumpNo	unsigned (3)	dump specification number producing this dump (0-7)	
SciSeq	unsigned (5)	sequence number in this dump (0-16)	
DetectorCounts	unsigned (24)	total counts from detector event counter (114 bytes to here)	
AcqTime	unsigned (16)	commanded integration time	
AcqCount	unsigned (16)	commanded total count	

	(7)	unused
AcqControl	enum (1) 0 = time based 1 = count based	acquisition control (count or time)
TimeHack	unsigned (8)	time mark interval (format per hardware register)
WinLowSpectral	unsigned (16)	spectral window lower (inclusive), 0-1023
WinHighSpectral	unsigned (16)	spectral window upper (inclusive), 0-1023
WinLowSpatial	unsigned (8)	spatial window lower, 0-31
WinHighSpatial	unsigned (8)	spatial window upper, 0-31
TotalPixels	unsigned (16)	total events in acquisition
PixelItems	unsigned (16)	count of events in packet (in PixelData field)
StartAddr	unsigned (16)	starting memory address of events in packet
PixelData	unsigned (16) X 1931	list of events (max N = 3994-132 = 3862 octets → 1931 words)
<b>Notes:</b>		
<p>-Housekeeping data item is the same as data field of housekeeping data telemetry packet, not including SID.</p> <p>-Parameter data item is the same as data field of context telemetry packet (18,2)</p> <p>-Total packet length is variable depending on quantity of science data. (estimated overhead 132 octets, remainder is pixel list; up to 3862 octets/1931 pixels)</p> <p>-All of the packet fields from the beginning to the DetectorCounts field (inclusive) are common to all science data packets.</p> <p>-The PixelData field is always 1931 words long. The total number of items stored may be less and is indicated by the PixelItems field.</p> <p>-The StartAddr field indicates the starting address in acquisition memory of the first pixel in the PixelData field. Note that addresses are not necessarily contiguous due to windowing.</p>		

<b>Telemetry Packet Definition (Alice)</b>			
Packet Name	Science count rate	Instrument	Alice
Packet Function	provide count rate mode science data		
Generation Rules	receipt of Multiple acquire Dump telecommand (192,26) when specified dump is executed and count rate mode data available, one dump can consist of up to 17 TM packets		
<b>Header Information</b>			
Process ID	92	Packet Category	12
Service Type	20	Service Subtype	3
Structure ID	2	Packet Length	3994 max data
<b>Data Field Information</b>			
Data Field	Field Structure	Remarks	
SID	enum (16)	value = 2	
McpMaxV	unsigned (8)	MCP high level during acquisition (ADC counts)	
McpMinV	unsigned (8)	MCP low level during acquisition (ADC counts)	
McpStartV	unsigned (8)	MCP level at start of acquisition (ADC counts)	
McpStopV	unsigned (8)	MCP level at stop of acquisition (ADC counts)	
StripMaxI	unsigned (8)	strip current high level during acquisition (ADC counts)	
StripMinI	unsigned (8)	strip current low level during acquisition (ADC counts)	
StripStartI	unsigned (8)	strip current at start of acquisition (ADC counts)	
StripStopI	unsigned (8)	strip current at stop of acquisition (ADC counts)	
HkData	unsigned (8) * 44	housekeeping data (see notes)	
ParmData	unsigned (8) * 42	configuration data/context (see notes)	
PressMax	real (8-special)	high ROSINA pressure reported during acquisition, minimum value if no ROSINA pressure reported during acquisition	
PressMin	real (8-special)	low ROSINA pressure reported during acquisition, maximum value if no ROSINA pressure reported during acquisition	
StartTime	time (48)	acquisition start time	
StopTime	time (48)	actual stop time	
DumpNo	unsigned (3)	dump specification number producing this dump (0-7)	
SciSeq	unsigned (5)	sequence number in this dump (0-16)	
DetectorCounts	unsigned (24)	total counts from detector event counter (114 bytes to here)	
AcqCount	unsigned (16)	commanded total count	
AcqInterval	unsigned (16)	acquisition interval (milli seconds) fails; calculated value is only a single byte in size and does not fill the telemetry field.	
TotalItems	unsigned (16)	total items in acquisition	
PktItems	unsigned (16)	count of items in packet	
StartItem	unsigned (16)	start item number in packet	
Data	unsigned (16) X N	list of N count rate items (max N = 3994-124 = 3870 octets → 1935 words)	
<b>Notes:</b>			
-Housekeeping data item is the same as data field of housekeeping data telemetry packet, not including SID.			

-Parameter data item is the same as data field of context telemetry packet (18,2)  
 -Total packet length is variable depending on quantity of science data.  
 (estimated overhead 124 octets, remainder is count rate data; up to 3870 octets/1935 items)  
 -All of the packet fields from the beginning to the DetectorCounts field (inclusive) are common to all science data packets.

<b>Telemetry Packet Definition (Alice)</b>			
Packet Name	Diagnostics	Instrument	Alice
Packet Function	Provide Alice non-routine diagnostic data		
Generation Rules	Periodic at same rate as housekeeping data when enabled by parameter (default is off)		
<b>Header Information</b>			
Process ID	92	Packet Category	12
Service Type	20	Service Subtype	3
Structure ID	4	Packet Length	60 data
<b>Data Field Information</b>			
Data Field	Field Structure	Remarks	
SID	enum (16)	value = 4	
DgNextCycleTime	time (48)	calculated time for the start of the next acquisition cycle (updated after the completion of the dump phase)	
DgTotalCycles	unsigned (8)	total number of commanded Multiple Acquire Dump Cycles	
DgPhaseMAD	enum (8)	current MAD execution phase, includes acquisition type (when active) and dump cycle (when active)	
DgTaskStack	10*unsigned (8)	value of stack pointer for all 10 active AFS tasks	
DgMinFreeStack	unsigned (8)	minimum amount of free stack space detected during the last HK/Diagnostics reporting period	
DgFirstDeleted	enum (8)	task number of the first deleted task (0-9); set to 10 if no deleted task exists	
DgAcqPtrPL	unsigned (16)	memory pointer for Pixel List acquisition (h/w)	
DgAcqPtrCR	unsigned (16)	memory pointer for Count Rate acquisition (s/w)	
DgPressLimitTime	time (48)	calculated time at which the pressure limit would be reached based on Rosina reported pressure and trend	
DgRejectedSmall	unsigned (16)	count of tm interface rejected "small" packets	
DgRejectedLarge	unsigned (16)	count of tm interface rejected "large" packets	
DgTotalSent	unsigned (16)	count of total packet transmitted	
DgListSize	unsigned (8)	count of packets in list	
DgHeapBlocks	unsigned (8)	number of blocks in heap	
DgHeapFree	unsigned (16)	free bytes in heap	
DgHeapBiggest	unsigned (16)	largest free block on the heap	
DgTcTimeouts	unsigned (16)	count of telecommand timeouts	
DgTcBadApid	unsigned (16)	count of bad TC APIDs	
DgTcBadCrc	unsigned (16)	count of bad TC CRCs	
DgTcBytesReceived	unsigned (16)	total bytes received on TC interface	
DgTcAccepted	unsigned (16)	count of accepted tc packets	
DgTcRejected	unsigned (16)	count of rejected tc packets	
DgRtxIdle	unsigned (16)	count of passes through idle loop (in monitoring cycle)	
DgRtxSched	unsigned (16)	count of calls to scheduler (in monitoring cycle)	
<b>Notes:</b>			
This packet is produced on a periodic basis with housekeeping data (3,25) if science output is enabled and the parameter PmDiagEnable is set to a non-zero value. The data in this packet is strictly for engineering evaluation of performance and for diagnostic purposes. It has no scientific value and does not need to be interpreted on board or by the science data processing system.			
The DgPhaseMAD parameter indicates the progress of the current Multiple Acquire Dump command:			
0	free	no Multiple Acquire Dump command active	
1	init	Multiple Acquire Dump processin started	
2	loop	started the main loop of the Multiple Acquire Dump cycle	
3	wait	waiting until it is time to start the acquire phase of the Multiple Acquire Dump cycle	
4	safe	acquisition phase skipped because of active unmasked safety condition	
5+mode	acquisition	acquiring data in the specified mode (0-3 see specification of Multiple Acquire Dump telecommand)	
10+spec	dump	executing one of the specified data dumps (0-7 see specification of Multiple Acquire Dump telecommand)	
The DgTaskStack indicates the current value of the stack pointer of each of the 10 tasks active in the Alice Flight Software (tskMain, tskDetector, TskHvps, tskSafety, tskTclf, tskTmlf, tskDoor, tskHk, tskHeater and tskSlowTc). This list also specifies the tasknumber as used to indicate the first deleted task as reported in the DgFirstDeleted parameter.			

<b>Telemetry Packet Definition (Alice)</b>			
Packet Name	Parameter Dump	Instrument	Alice

Packet Function	Provide dump of <i>Alice</i> internal parameter file		
Generation Rules	On receipt of get parameters telecommand (192,25)		
<b>Header Information</b>			
Process ID	92	Packet Category	12
Service Type	20	Service Subtype	3
Structure ID	5	Packet Length	44 data
<b>Data Field Information</b>			
Data Field SID	Field Structure enum (16)	Remarks value = 5	
ParmData	unsigned (8) * 40	configuration data/context (see notes)	
<b>Notes:</b>			
ParmData field has the same content and format as the context packet (18,2).			

### 6.3 Event Packet Definitions

Detailed description of event packets is included in the Telemetry Packet Definition in Section 6.2, this section provides an overview of the Event packets used by *Alice*.

Table 6-1 – Event packet summary

Event	Packet	Event ID	Severity	Description
1,1	YALST001	N/A	N/A	Telecommand Acceptance Success
1,2	YALST002-007	N/A	N/A	Telecommand Acceptance Failure
1,7	YALST008	N/A	N/A	Telecommand Execution Success
1,8	YALST009	N/A	N/A	Telecommand Execution Failure
5,1	YAL00002	40001	Normal Progress Report	Aperture door motion event
5,2	YAL00003	40002	Error Report - no action	Aperture door motion error event
5,1	YAL00004	40003	Normal Progress Report	Indicate instrument high voltage changed
5,2	YAL00005	40004	Error Report - no action	Parameter read warning event
5,4	YAL00006	40005	Error Report - on-board action	Parameter read error event
5,3 5,4	YAL00007, YAL00008	40006	Error Report – ground, Error Report – on-board	Safety event
5,1	YAL00009	40007	Normal Progress Report	Power-on event
5,1 5,2	YAL00015, YAL00016	40008	Normal Progress Report, Error Report – no action	Acquisition event, start cycle Acquisition event: safety active, start missed

### 6.4 Anomaly Report Definitions

Not Applicable. (*Alice* does not output anomaly reports.)

## 6.5 Context File Definition

The table below lists the 42 bytes of *Alice* context information and the default values of the parameters. The list matches the parameters in the load and store context parameters telecommand (service #18).

Table 6-2 – Parameter List(context) with Default Values as of July 2015 (for remainder of escort phase)

#	Parameter	Default value	Description
0	HTRSENSEGRATING	0	0-primary temperature sensor (1-secondary)
1	HTRSENSEMIRROR	0	0-primary temperature sensor (1-secondary)
2	DOORENABLE	1	1-close on safety, 0-dont close
3	DACADCFACOR	231	multiplication factor to convert from HV DAC to ADC (factor/240)
4	EVENTSAFETY	0	0-ground safety event (1-on-board event)
5	DISCRIMINATOR	40	discriminator level set point, commanded at start of acquisition [PROM value = 30]
6	HOTSEG1	0	all hot segment registers are initialized to zero (bottom left corner of detector array)
7	HOTSEG2	0	
8	HOTSEG3	0	
9	HOTSEG4	0	
10	HOTSEG5	0	
11	HOTSEG6	0	
12	HOTSEG7	0	
13	HOTSEG8	0	
14	HVLEVEL	149	-4.1kV; high voltage set point (DAC counts), commanded at start of acquisition [PROM value = 5 = -252 V]
15	HVSTEPsize	4	~ 94 V; DAC counts for HV steps during HV rampup
16	HVRUNTIME	2	~ 192ms; HVPS task run interval, both for steps and checks specified in kernel clock ticks
17	HVMAXSTRIPI	168	~ 1 uA; maximum accepted strip current, in ADC counts
18	HVMINANODEV	188	~ 550 V; minimum accepted anode voltage when HV setting is reached, in ADC counts
19	HVMAXANODEV	245	~ 650 V; maximum anode voltage, in ADC counts
20	HVMCPTOL	8	~ 200 V; allowed McpV->HvSet error, ADC->DAC
21	HVFAILANODE	4	anode voltage fail counter, number of consecutive failures before safety is raised
22	HVFAILMCP	4	mcp fail counter, number of consecutive failures before safety is raised
23	HVFAILSTRIP	4	strip current fail counter, number of consecutive failures before safety is raised
24	DOORTIMEOUT	2	aperture door motion timeout, approximately specified in seconds
25	COUNTERINTERVAL	10	detector count rate time base, kernel ticks
26	COUNTSLOTS	100	count rate slots for histo mode, fixed at compile time (do not change unless recompiling software)
27	MAXPRESSURE	21	= 1e-5 mbar; maximum accepted Rosina pressure (both for alert and trend safety), in Rosina real format (see EID-B) [note that the hex value 0x15 → 1e-5 mbar]
28	PRESSTIMEMARGIN	60	pressure trend time margin, in seconds*10
29	MAXTEMP	192	~ 58 C; max allowed temperature, specified in ADC counts

#	Parameter	Default value	Description
30	TEMPMASK	255	temperature sensor bit mask, all temperature sensors enabled specified in same order as reported in HK packet
31	HTRTOLGRATING	8	grating temperature tolerance, ADC counts
32	HTRTOLMIRROR	8	grating temperature tolerance, ADC counts
33	TESTMASK	0	self-test bit mask, no tests selected
34	HKRATE	30	housekeeping rate, in seconds
35	DGENABLE	0	additional diagnostics data generation disabled
	MAXCOUNTRATE	14912	max allowed counts per interval (16 bits) [PROM value = 40000] Value changed throughout mission. (combined bytes of parameters 36 and 37)
36	HI_MAXCOUNTRATE	58	high byte: MAXCOUNTRATE / 256 [PROM value = 156]
37	LO_MAXCOUNTRATE	64	low byte: MAXCOUNTRATE % 256
	SAFETYTIMEOUT	600	safety timeout, in seconds (16 bits) (combined bytes of parameters 38 and 39)
38	HI_SAFETYTIMEOUT	2	high byte: SAFETYTIMEOUT / 256
39	LO_SAFETYTIMEOUT	88	low byte: SAFETYTIMEOUT % 256
	MAXDUST	30	dust flux limit in counts/m <sup>2</sup> /min from GIADA (16 bits) (combined bytes of parameters 40 and 41)
40	HI_MAXDUST	0	high byte: MAXDUST / 256
41	LO_MAXDUST	30	low byte: MAXDUST % 256

## 6.6 Data and Dump File Definitions

In general *Alice* only uses unstructured memory dumps to verify the contents of PROM and EEPROM memory areas, although the command set allows for memory dumps of all used memory types. A special predefined case is the dump of the results of the Door Performance Measurement. The Door Performance Measurement is a special embedded function that can be activated by a commanded jump to a specific address in the code memory space. This function was added in version 2.04 of the flight software. The measurement results are stored in a cyclic buffer located at address 0x b600. After performing a number of door performance measurements the results can be retrieved by dumping this 128 byte memory buffer. The buffer contains up to 64 entries of 4 words (16 bits) each. Each entry in the buffer describes the timing results of one commanded door movement cycle (flap). For each move (open/close) two parameters are measured indicating when the movement started and when the movement completed. The results of the measurement are reported in units of 33 microseconds:

- Open start movement
- Open completed movement
- Close start movement
- Close completed movement

### 6.7 SSMM Utilization

SSMM Utilisation		Mission Phase: any	Instrument: <i>Alice</i>
Data Type	Description	Volume MByte	Operational Usage
Non-science Telemetry	periodic housekeeping	46 octets per 30 seconds	46 bytes HK data every 30 seconds (nominal) when instrument operating, can be adjusted by telecommand for a rate between once per second to once per 255 seconds
Non-science Telemetry	periodic diagnostic data	60 octets per 30 seconds	Generated at the same rate (and time) as the housekeeping packets, packets actually have a science packet ID
Context	instrument context	42 octets	Loaded from SSMM every time when instrument starts, saved to SSMM after modifications (separate telecommand)
Event	instrument operating and error events	limited, largest event package is 6 bytes	Instrument generated event packages generated both during nominal processing and for non-nominal error reporting
Memory Dumps	instrument memory dumps	up to 128 kbyte	Incidental memory dumps for problem investigation form one of the four instrument memory types during non-nominal operations
	door performance data	128 bytes	Incidental results of door performance measurements, results are accessed using the memory dump service to retrieve table of results
Science Telemetry	acquired science data	depending on acquisition mode and dump selection	Depending on acquisition modes and specified data dumps, see MAD telecommand (ZAL19226) and data production/selection rates (section 2.3.3)
S/W patches	software patches to be loaded into the instrument non-volatile memory	32 kbytes transient only	<i>Alice</i> now has non-volatile memory and does not require permanent spacecraft storage of patches.

### 6.8 Information Distribution Requirements

During the initial mission this information is not required by the *Alice* instrument, as these mechanisms are used to protect *Alice* from cometary contamination. One the spacecraft is operating in the comet vicinity fast reaction to protect the *Alice* instrument is needed and these data flows are used in that process.

INFORMATION REQUIRED		Instrument	<i>Alice</i>
Entity	Requirements	Remarks	
<b>Parameters</b>			
Rosina Pressure Distribution (19,10)	periodic pressure whenever <i>Alice</i> operating	<i>Alice</i> required rate is as needed	
Rosina Pressure Alert (19,11)	one-shot pressure alert message when pressure exceeds Rosina defined value	<i>Alice</i> uses both Rosina data distributions in an identical way required rate applies therefore to combined alert and distribution messages	
Dust Flux (19,12)	periodic dust flux measurement	<i>Alice</i> required rate is as needed	
<b>Events</b>			
none			

INFORMATION OFFERED		Instrument	<i>Alice</i>
<i>Alice</i> offers no information			



## 6.9 On-Board Control Procedures

*Alice* operations currently use only two OBCPs, as documented in: *Alice* Experiment OBCP User Requirements Document (RO-DSS-RS-1023 Issue 1F, Date July 22 2002).

ON-BOARD CONTROL PROCEDURES (OBCP) SUMMARY		Instrument	<i>Alice</i>
OBCP Name	Function		Usage
1: startup	powers up instrument, runs patch if needed, sets time, loads context		N
2: shutdown	commands instrument to safe state prior to shutdown		N

### OBCP Startup

This OBCP is used to start *Alice*.

Inputs: memory configuration (0xff=no patch); memory address

PDL:

- turn power on
- wait for power-on event packet
- IF patch specified (address <> 0xffff)
- issue start TC (192,24) with config and address parameters
- wait for power on event packet
- ENDIF
- time update
- load context
- enable housekeeping

### OBCP shutdown

- command safe state
- wait 10 seconds
- power off

## 6.10 *Alice* PAD Field Handling

For the *Rosetta* S/C the CCSDS defined PAD<sup>3</sup> field is used as an additional identification for TM packets. *Rosetta* defines 'solicited TM' data generated in direct response to a TC. The PAD field in 'solicited TM' should contain a copy of the PAD field of the requesting TC. This functionality only was implemented in the version 2.05 of the *Alice* software, so the instrument will only fully comply with this requirement when executing the version 2.05 code (after restart in EEPROM).

The original versions of the *Alice* Flight Software (version 2.04, as of September 2004, and previous version 2.03) copies the PAD field from a telecommand soliciting a direct response to the TM packet being generated for the following TM packets:

- TM( 6, 6)      Memory Dump
- TM( 6,10)     Memory Check
- TM(17, 2)     Connection Test Report
- TM(18, 2)     Context Report
- TM(20, 3):5   *Alice* Science packet with SID = 5: Parameter dump (in direct response to the private TC(192,25) Get Parameter File, which is handled the same as Get Context)

This copying (EID-A 2.7.2.1, page 15) will only take place when the TM packet is considered a solicited TM packet according to Table 2.8.2-2, pages 56,57 AND the TC packet specifies that it solicits a

<sup>3</sup> PAD is a field in TM defined as a 'filler' byte that ensures the 16-bit boundary alignment of the complete TM packet (see EID-B 2.7.2.1).

direct response by specifying a PUS field value of '010' (EID-A 2.7.2.2, page 18). In all other cases the PAD field of generated TM packets will be set to zero. Note that *Alice* does not copy the PAD field from any telecommand into the service #1 telemetry packets.

In version 2.05 (dated October 2006), the full PAD field copying functionality was added. It includes the copying of the PAD field from any telecommand into the service #1 telemetry packets.

## 7 Rosetta–Alice EQM and STB Configuration and Use

To support mission operations, an *Alice* EQM (Electrical Qualification Model) is maintained installed on the spacecraft EQM at ESOC in Darmstadt. The *Alice* EQM contains an electrical equivalent of the flight instrument that only lacks the optical components of the instrument. The electronic modules included in the EQM are LVPS, HVPS and Detector electronics. The EQM includes the door actuator, heater resistors and temperature sensors. The software configuration of the EQM is identical to the flight model; it contains the same software in PROM and also the EEPROM contents are maintained to match the EEPROM contents of the flight model. Regularly scheduled use of the EQM is not anticipated, but use of the EQM will be requested by the *Alice* team or ESA as necessary to test new sequences, verify revised versions of the *Alice* flight software, and trouble-shoot problems and anomalies.

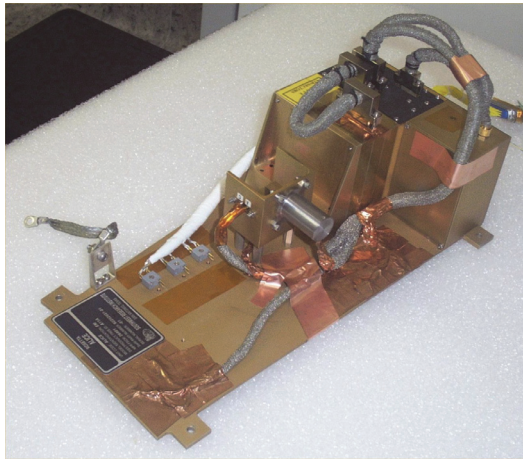

Figure 6.10-1 - Alice EQM

Also, a Software Test Bed (STB) is maintained at SwRI to provide additional mission support and software maintenance and testing. The STB is similar in configuration to the EQM but does not contain a HVPS. However, some simple circuitry simulates the read-back values from the HVPS. The STB also contains a flight identical LVPS and C&DH, and used the spacecraft interface simulator (SIS) to simulate the spacecraft environment. The STB allows for direct measurements on the electronics hardware and easy verification of command sequences. However, the STB is limited in that the spacecraft environment is simulated. The EQM allows for a more precise end-to-end verification of operational procedures. This is a useful tool if special non-nominal procedures have to be verified.

A complete set of spare parts for the EQM and STB were purchased in 2007 and kept at SwRI.

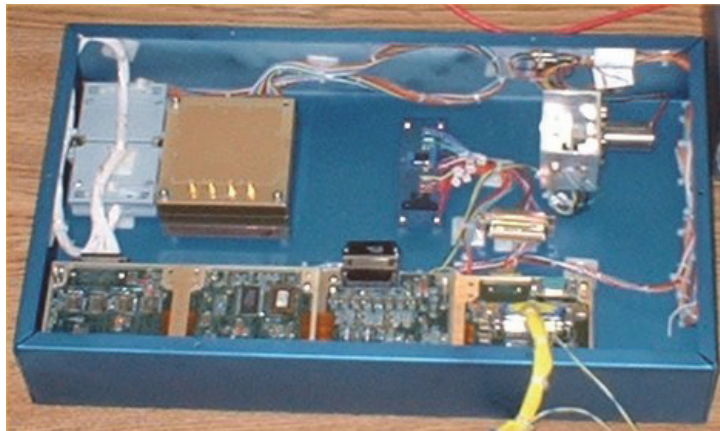

Figure 6.10-2 - Alice STB

## **8 Attachments**

### **8.1 Attachment 1: Alice Hot UV Star List**

### **8.2 Attachment 2: Alice In-Flight Aperture Door Performance Test**

# ATTACHMENT 1

## *Alice* Hot UV Star List (“Bad Dogs”)

Version Date: 2006 September 26

This list of “Bad Dog” stars (stars that create too-high of a count rate on the Alice detector) was created using model predictions based on data from the Yale Bright Star Catalog and Kurucz model stellar fluxes. An updated version of this list is in progress using actual International Ultraviolet Explorer (IUE) UV spectra with Kurucz models to more accurately determine the true stellar flux.

For this current list, the expected *Alice* count rates are predicted by convolving the *Alice* sensitivity curve (effective area over the wavelength range 700-2080 Å) with Kurucz models that are normalized to Vega’s IUE flux at 1500 Å of  $F(\text{iue\_vega}) = 6.40924\text{e-}09 \text{ erg/s/cm}^2/\text{Å}$ , using the Kurucz model Vega  $V = -39.2561$  mag, and normalizing to the residual  $V$  magnitude difference of each star. The following tables are for stars that produce more than 15,000 counts/sec based on these calculations. It is sorted by HD number (equivalent to sorting by RA).

Yale Bright Star Catalog (5th Edition)

HD	RA (2000)	Dec	V	Spectral Type	Name	Count/s
886	00:13:14.2	15:11:01	2.83	B2IV	88Gam Peg	17240
5394	00:56:42.5	60:42:60	2.47	B0IVe	27Gam Cas	65222
10144	01:37:42.9	-57:14:12	0.46	B3Vpe	Alp Eri	107707
24398	03:54:07.9	31:53:01	2.85	B1Ib	44Zet Per	32207
24760	03:57:51.2	40:00:37	2.89	B0.5V+A2V	45Eps Per	44299
24912	03:58:57.9	35:47:28	4.04	O7.5III(n) ((f))	46Xi Per	25411
30614	04:54:03.0	66:20:34	4.29	O9.5Ia	9Alp Cam	16230
31237	04:54:15.1	02:26:26	3.72	B3III+B0V	8Pi 5Ori	20625
34085	05:14:32.3	-08:12:06	0.12	B8Ia:	19Bet Ori	15139
35411	05:24:28.6	-02:23:49	3.36	B1V+B2e	28Eta Ori	20135
35468	05:25:07.9	06:20:59	1.64	B2III	24Gam Ori	51589
36486	05:32:00.4	-00:17:57	2.23	O9.5II	34Del Ori	108224
36861	05:35:08.3	09:56:03	3.54	O8III((f))	39Lam Ori	36283
37043	05:35:26.0	-05:54:36	2.77	O9III	44Iot Ori	65815
37128	05:36:12.8	-01:12:07	1.70	B0Ia	46Eps Ori	132554
37468	05:38:44.8	-02:35:60	3.81	O9.5V	48Sig Ori	25253
37742	05:40:45.5	-01:56:34	2.05	O9.7Ib	50Zet Ori	127740
38771	05:47:45.4	-09:40:11	2.06	B0.5Ia	53Kap Ori	95146
44743	06:22:42.0	-17:57:21	1.98	B1II-III	2Bet Cma	71772
52089	06:58:37.5	-28:58:20	1.50	B2II	21Eps Cma	58689
66811	08:03:35.1	-40:00:12	2.25	O5f	Zet Pup	157085
68273	08:09:32.0	-47:20:12	1.78	WC8+O9I	Gam2Vel	278424
71129	08:22:30.8	-59:30:35	1.86	K3III+B2:V	Eps Car	42126
81188	09:22:06.8	-55:00:39	2.50	B2IV-V	Kap Vel	23364
93030	10:42:57.4	-64:23:40	2.76	B0Vp	The Car	49933
105435	12:08:21.5	-50:43:21	2.60	B2IVne	Del Cen	21308
106490	12:15:08.7	-58:44:56	2.80	B2IV	Del Cru	17723
108248	12:26:35.9	-63:05:57	1.33	B0.5IV	Alp1Cru	186378
108249	12:26:36.5	-63:05:58	1.73	B1V	Alp2Cru	90356
109668	12:37:11.0	-69:08:08	2.69	B2IV-V	Alp Mus	19613
111123	12:47:43.2	-59:41:19	1.25	B0.5III	Bet Cru	200629
116658	13:25:11.6	-11:09:41	0.98	B1III-IV+B2V	67Alp Vir	180284
118716	13:39:53.2	-53:27:59	2.30	B1III	Eps Cen	53451
120315	13:47:32.4	49:18:48	1.86	B3V	85Eta UMa	29665
121263	13:55:32.4	-47:17:18	2.55	B2.5IV	Zet Cen	22313
122451	14:03:49.4	-60:22:23	0.61	B1III	Bet Cen	253488
127972	14:35:30.4	-42:09:28	2.31	B1.5Vne	Eta Cen	52961
129056	14:41:55.8	-47:23:18	2.30	B1.5III/Vn	Alp Lup	53451

132058	14:58:31.9	-43:08:02	2.68	B2III/IV	Bet Lup	19795
136298	15:21:22.3	-40:38:51	3.22	B1.5IV	Del Lup	22906
138690	15:35:08.5	-41:10:01	2.78	B2IV	Gam Lup	18053
143018	15:58:51.1	-26:06:51	2.89	B1V+B2V	6Pi Sco	31042
143275	16:00:20.0	-22:37:18	2.32	B0.3IV	7Del Sco	74884
144217	16:05:26.2	-19:48:20	2.62	B1V	8Bet1Sco	39806
147165	16:21:11.3	-25:35:34	2.89	B1III	20Sig Sco	31042
148478	16:29:24.4	-26:25:55	0.96	M1.5Iab-Ib+B4Ve	21Alp Sco	44297
149438	16:35:53.0	-28:12:58	2.82	B0V	23Tau Sco	47249
149757	16:37:09.5	-10:34:02	2.56	O9.5Vn	13Zet Oph	79859
151890	16:51:52.2	-38:02:51	3.08	B1.5V+B6.5V	Mu 1Sco	26058
157246	17:25:23.6	-56:22:39	3.34	B1Ib	Gam Ara	20509
158408	17:30:45.8	-37:17:45	2.69	B2IV	34Ups Sco	19613
158427	17:31:50.5	-49:52:34	2.95	B2Vne	Alp Ara	15436
158926	17:33:36.5	-37:06:14	1.63	B2IV+B	35Lam Sco	52066
160578	17:42:29.3	-39:01:48	2.41	B1.5III	Kap Sco	48301
175191	18:55:15.9	-26:17:48	2.02	B2.5V	34Sig Sgr	36354
193924	20:25:38.9	-56:44:06	1.94	B2IV	Alp Pav	39134
205021	21:28:39.6	70:33:39	3.23	B1IV	8Bet Cep	22696

Total Bad Dog stars: 57

WC V<4.95 [1]  
O5 V<4.80 [1]  
O7 V<4.61 [1]  
O8 V<4.50 [1]  
O9 V<4.38 [6]  
B0 V<4.07 [10]  
B1 V<3.68 [17]  
B2 V<2.98 [16]  
B3 V<2.60 [2]  
B4 V<2.14 [1]  
B8 V<0.13 [1]

The magnitudes as a function of spectral type listed above can be used as a *rough* guideline for identifying Bad Dogs. The actual UV flux is a strong function of the reddening of the star.

## ATTACHMENT 2

### *Alice* In-Flight Aperture Door Performance Test Results

During the software patch verification the added door performance test function was used for the first time. Four cycles were performed, showing very constant operation times, average operation times were:

9/2/2004	Start movement	End movement
Door open	17.9 ms	70.0 ms
Door close	17.1 ms	76.5 ms

A more extensive door measurement was scheduled as a separate commissioning activity on 9/28/2004. These measurements were executed 4 quick cycles in a row followed by a 5-minute wait period, resulting in a total execution time of almost an hour. Here the results of 36 cycles were obtained and the average numbers seem to be very much in line with the earlier measurements:

9/28/2004	Start movement	End movement
Door open	18.4 ms	69.7 ms
Door close	16.9 ms	75.1 ms

Further inspection of this data though showed a surprising rising trend in the end door close times. This test was performed after the instrument had been on for 3 hours for a decontamination procedure and measured temperatures during this test are nearly constant. Also note that in between these two door measurement activities the door was operated more than 300 cycles during the interference test. Further investigation of the results did not result in an explanation. Even though the actual movement itself is still very quick the clear trend is a reason for concern and further evaluation will be needed.

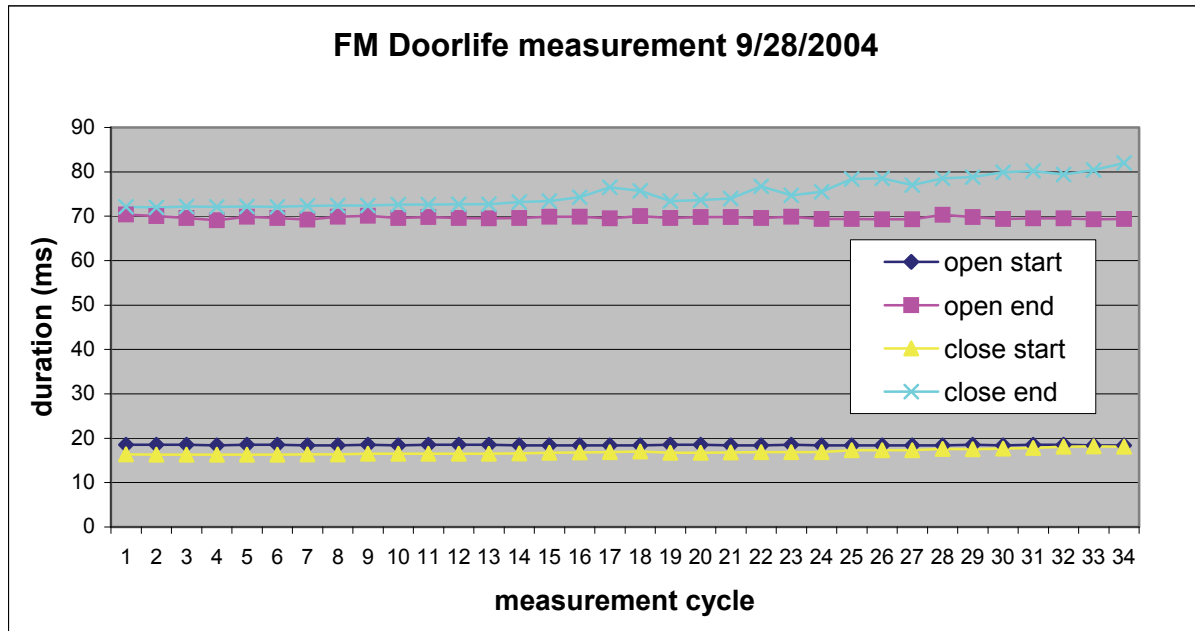

As part of the investigation into the observed trends a similar measurement was performed on the Software Test Bed (STB). The STB includes a door simulator that consists of an identical motor and two

optical switches. The mechanical construction is different so the measured operation times will also be different. A test sequence was defined that performed door operations with the same timing as the door life measurement that was performed on the instrument. The test was allowed to run for about 4 hours but no trend was observed in the door measurements.

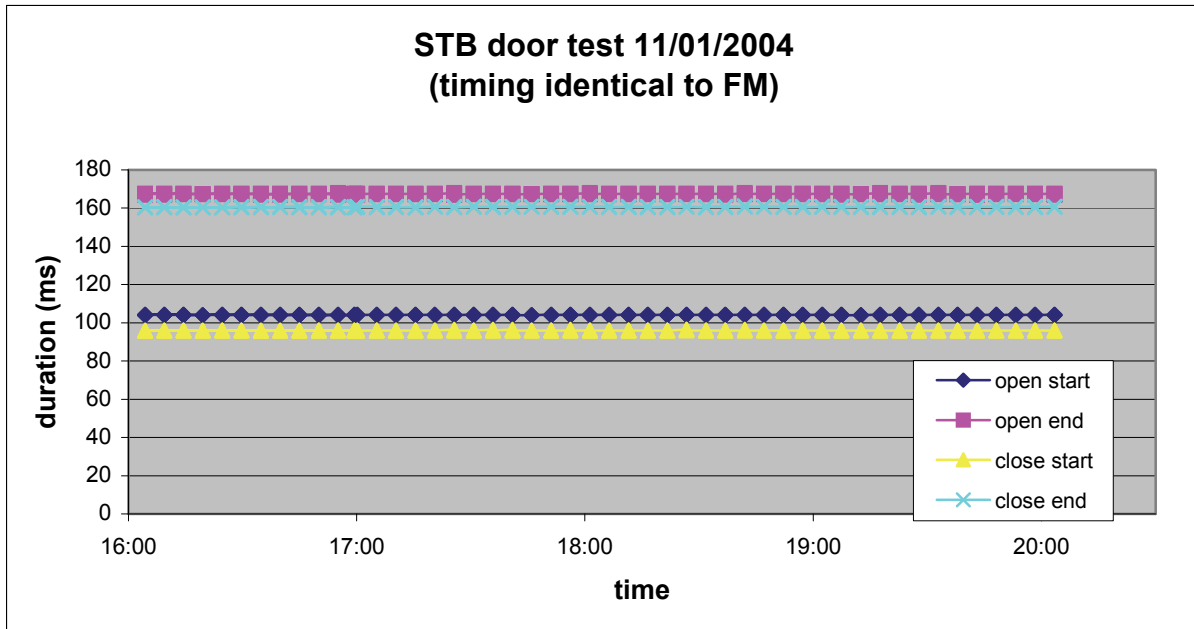

Below we show the plot of all aperture door performance tests that have run since launch through active checkout #10 (PC10):

