

**esa****DOCUMENT**

document title/ titre du document

HERSCHEL GROUND SEGMENT

DESIGN DESCRIPTION

prepared by/ préparé par	HGSSE group
reference/référence	FIRST/FSC/DOC/0146
issue/édition	1
revision/révision	4
date of issue/date d'édition	04/10/04
status/état	Approved/Applicable
Document type/type de document	Conceptual Design Description
Distribution/distribution	

European Space Agency
Agence spatiale européenne

ESTEC

Keplerlaan 1 - 2201 AZ Noordwijk - The Netherlands
Tel. (31) 71 5656565 - Fax (31) 71 5656040

A P P R O V A L

Title <i>titre</i>	HERSCHEL Ground Segment System Design Description	issue <i>issue</i>	1	revision <i>revision</i>	4
------------------------------	---	------------------------------	---	------------------------------------	---

author <i>auteur</i>	<p>HGSSE:</p> <p>The HGSSE group is composed of:</p> <ul style="list-style-type: none"> • Luis Aloy (ESTEC/HP-Project) • Kevin Galloway (ESTEC/HSC) • Gianpiero Di Girolamo (ESOC/MOC) • Ana Heras (ESTEC/HSC) • Pjotr Roelfsema (SRON/HIFI) • Micha Schmidt (ESOC/MOC) • Sunil Sidher (RAL/SPIRE) • Bart Vandenbussche (KUL/PACS) 	date <i>date</i>	04/10/04
--------------------------------	--	----------------------------	----------

approved by
approuvé by

Otto Bauer
(PACS ICC Manager)

date
date

Ken King
(SPIRE ICC Manager)

Peter Roelfsema
(HIFI ICC Manager)

John Dodsworth
(H/P Ground Segment Manager)

Göran Pilbratt
(Herschel Project Scientist)

C H A N G E L O G

<i>reason for change /raison du changement</i>	<i>issue/issue</i>	<i>revision/revision</i>	<i>date/date</i>
First draft	0	1	05/09/2000
ILT section updated in preparation of the FGSSE/EGSE meeting on the 09-10 October 2000	0	2	02/10/2000
First Issue for ILT	1	0	03/11/2000
Update after HCSS SRR at ESTEC and follow-up HGSSE meetings #11, #12, #13, #14, and #15	1	1	10/12/2001
See Issue 1.2 change record below.	1	2	11/12/2003
See Issue 1.3 change record below	1	3	08/06/2004
See Issue 1.4 change record below	1	4	04/10/2004

CHANGE RECORD

ISSUE: 1 REVISION: 1

reason for change/ <i>raison du changement</i>	page(s)/ <i>page(s)</i>	paragraph(s)/ <i>paragraph(s)</i>
<ul style="list-style-type: none"> • Editorial changes <ul style="list-style-type: none"> • FIRST → Herschel • FINDAS → HCSS or appropriate description • relevant acronyms changed letter F into H • syntax and typos • Signature list added • Table of figures added • Herschel Operations Scenario Document is listed as an applicable document • Updated figures <ul style="list-style-type: none"> • HGS in routine phase • Overview of the communication network • HGS in ILT • HGS in IST • Concept of TM data processing (new figure) • Section on commonality between instruments written • Section on FINDAS rewritten to HCSS core services and ODBMS • Resolutions of TBDs, TBCs, and TBWs. Detailed of the discussions leading to the resolution of these are recorded in MoM of HGSSE#12 and HGSSE#13. • Added dataframe definition and explanation about on-board compression on-ground decompression scheme. • IST section remains largely TBC 	<p>All pages</p> <p>p 3</p> <p>p 10</p> <p>p 12</p> <p>p 21</p> <p>p 32</p> <p>p 54</p> <p>p 62</p> <p>p 46</p> <p>p 16</p> <p>All pages</p>	<p>n/a</p> <p>2.1.4</p> <p>3.1.2.9</p> <p>3.1.2.8</p> <p>3.3</p>

CHANGE RECORD

ISSUE: 1 REVISION: 4

<i>reason for change/raison du changement</i>	<i>page(s)/page(s)</i>	<i>paragraph(s)/paragraph(s)</i>
<ul style="list-style-type: none"> The use of the file transfer system (FTS) has been introduced (as agreed in HGSSE meeting #25). 	35	3.1.3.2.3
	42	3.1.3.6
	43, 44	3.1.3.7
	47	3.1.8
	51	3.1.8.3
	53	3.1.8.5
<ul style="list-style-type: none"> Section on mission planning made consistent with mission planning concepts document (HGSSE AI#041203/12) 	54	3.1.8.7
	41-42	3.1.3.6

T A B L E O F C O N T E N T S

1	Introduction.....	13
1.1	SCOPE AND PURPOSE.....	13
1.2	REFERENCES	14
1.2.1	Applicable documents	14
1.2.2	Reference documents.....	14
1.3	ACRONYMS AND DEFINITION.....	14
2	System overview.....	15
2.1	OPERATION CONCEPTS.....	15
2.1.1	Geographical distribution	15
2.1.2	Satellite daily telecommunication period (DTCP)	16
2.1.3	Smooth transition across mission phases	18
2.1.4	Commonality between instruments	18
2.2	THE HERSCHEL GROUND SEGMENT DESIGN CONCEPTS	19
2.2.1	Introduction	19
2.2.2	The Herschel Common Science System (HCSS)	19
2.2.3	Smooth transition across mission phases	21
2.2.4	Geographical distribution across different centres	22
3	System Design.....	24
3.1	ROUTINE OPERATIONS PHASE.....	24
3.1.1	Introduction	24
3.1.2	HCSS components.....	25
3.1.2.1	Common Uplink System (CUS)	25
3.1.2.2	Proposal Handling System (PHS).....	27
3.1.2.3	Mission Planning System (MPS)	28
3.1.2.4	Standard Product Generation/ Quality Control Processing (SPG/ QCP).....	29
3.1.2.5	Configuration Control System (CC).....	29
3.1.2.6	Archive Browsers.....	30
3.1.2.7	Interactive Analysis (IA).....	30
3.1.2.8	Quick Look Analysis (QLA)	30
3.1.2.9	The HCSS core services and the ODBMS.....	31
3.1.3	MOC system components	32
3.1.3.1	Ground Station Network.....	33
3.1.3.2	Communications	34
3.1.3.3	Mission Control Centre	36
3.1.3.4	Flight Dynamics Service.....	39
3.1.3.5	Spacecraft and Instrument Simulator	40
3.1.3.6	Mission Planning	42
3.1.3.7	Data Distribution	42
3.1.3.8	On-board software development and maintenance	45
3.1.4	Real time analysis (RTA).....	45
3.1.5	Instrument On-board Software Maintenance (OBSM).....	46
3.1.6	MIB Editor.....	46
3.1.7	Instrument simulator	46
3.1.8	HSC-MOC interfaces	47
3.1.8.1	The telemetry interface towards MOC	47

3.1.8.2	The telemetry interface towards the HCSS.....	47
3.1.8.3	The MOC software and data interface towards HSC	51
3.1.8.4	MOC software and data interface towards the HCSS	52
3.1.8.5	The schedule interface towards MOC.....	53
3.1.8.6	The schedule interface towards the HCSS	53
3.1.8.7	The ICC data interface towards MOC	53
3.1.8.8	The ICC data interface towards the HCSS.....	54
3.1.9	HSC—ICC interfaces	54
3.1.10	HCSS—RTA interfaces	54
3.1.11	HCSS—OBSM interface	55
3.1.12	HCSS—MIB editor interface	55
3.2	INSTRUMENT LEVEL TEST (ILT) PHASE.....	56
3.2.1	Introduction	56
3.2.1.1	Smooth transition.....	56
3.2.1.2	Specific HGS functions that have to be emulated.....	56
3.2.1.3	Commonality	57
3.2.1.4	The ILT set-up	57
3.2.2	HCSS components for ILT	58
3.2.2.1	CUS.....	58
3.2.2.2	PHS	59
3.2.2.3	MPS	59
3.2.2.4	QCP.....	59
3.2.2.5	CC	59
3.2.2.6	Database browsers.....	59
3.2.2.7	IA/QLA	59
3.2.2.8	HCSS-ODBMS.....	59
3.2.3	EGSE-ILT components	60
3.2.3.1	Test Control.....	60
3.2.3.2	Commanding	61
3.2.3.3	The Telecommand/ Telemetry Interface Unit	61
3.2.3.4	On-board Software Management	61
3.2.4	RTA (monitoring).....	61
3.2.5	Instrument On-board Software Maintenance (OBSM).....	62
3.2.6	MIB editor	62
3.2.7	HCSS—EGSE-ILT interfaces	62
3.2.7.1	Test Control interface.....	62
3.2.7.2	OBS interface	63
3.2.7.3	Telemetry interface	63
3.2.7.4	Telecommand history interface.....	64
3.2.7.5	MIB interface	64
3.2.8	HCSS—RTA interface	64
3.2.9	HCSS—OBS maintenance interface.....	64
3.2.10	HCSS—MIB editor interface	64
3.3	INTEGRATED SYSTEM TEST (IST) PHASE	65
3.3.1	Introduction	65
3.3.1.1	Smooth transition.....	65
3.3.1.2	Specific HGS functions that have to be emulated.....	65
3.3.1.3	Commonality	66
3.3.1.4	The IST set-up	66
3.3.2	HCSS components for IST	67
3.3.2.1	CUS.....	67
3.3.2.2	PHS	68
3.3.2.3	MPS	68

3.3.2.4	QCP.....	68
3.3.2.5	CC.....	68
3.3.2.6	Database browsers.....	68
3.3.2.7	IA/ QLA.....	68
3.3.2.8	HCSS-ODBMS.....	68
3.3.3	CCS components.....	68
3.3.3.1	Test Control (CCS).....	68
3.3.3.2	Telemetry/ Telecommand FEE.....	68
3.3.3.3	FEE.....	69
3.3.3.4	On-board Software Management.....	69
3.3.4	Instrument -EGSE components.....	69
3.3.4.1	Test Control (EGSE).....	69
3.3.4.2	Telemetry router.....	69
3.3.5	RTA.....	69
3.3.6	On-board software maintenance (OBSM).....	69
3.3.7	MIB editor.....	70
3.3.8	HCSS—Instrument -EGSE Interfaces.....	70
3.3.8.1	Test Control interface.....	70
3.3.8.2	Telemetry interface.....	70
3.3.9	Instrument -EGSE—CCS interfaces.....	70
3.3.9.1	Test Control interface.....	70
3.3.10	HCSS—CCS interfaces.....	70
3.3.10.1	OBS interface.....	70
3.3.10.2	CCS data interface.....	70
3.3.10.3	MIB interface.....	71
3.3.11	HCSS—RTA interface.....	71
3.3.12	HCSS—OBS Maintenance interface.....	71
3.3.13	HCSS—MIB editor interface.....	71
3.4	GROUND SEGMENT TESTS.....	72
3.5	LAUNCH AND EARLY OPERATIONS PHASE (LEOP).....	72
3.6	COMMISSIONING PHASE.....	73
3.6.1	Introduction.....	73
3.6.1.1	The ground segment set-up during commissioning phase.....	73
3.6.2	The HCSS components for commissioning phase.....	74
3.6.2.1	CUS.....	74
3.6.2.2	PHS.....	74
3.6.2.3	MPS.....	75
3.6.2.4	QCP.....	75
3.6.2.5	CC.....	75
3.6.2.6	Database browsers.....	75
3.6.2.7	IA/ QLA.....	75
3.6.2.8	HCSS-ODBMS.....	75
3.6.3	MOC System components.....	75
3.6.3.1	Herschel Frame Decommulator.....	75
3.6.4	RTA.....	76
3.6.5	On-board Software Maintenance (OBSM).....	77
3.6.6	MIB editor.....	77
3.6.7	HSC—MOC interfaces.....	77
3.6.8	ICC@MOC—MOC interfaces.....	77
3.6.9	HSC—ICC@ICC interfaces.....	77
3.6.10	ICC@ICC—ICC@MOC interfaces.....	77
3.7	CALIBRATION/ PERFORMANCE VERIFICATION PHASE.....	79

3.8	SCIENCE DEMONSTRATION PHASE	79
3.9	POST-OPERATIONS PHASE	80
3.9.1	Introduction	80
3.9.2	HCSS components in post-operations	80
3.9.3	RTA	80
3.9.4	On-board software Maintenance (OBSM)	81
3.9.5	MIB Editor.....	81
3.9.6	HSC—ICC interfaces	81
4	Feasibility and resource estimates.....	81

T A B L E O F F I G U R E S

FIGURE 1: THE HERSCHEL GROUND SEGMENT CENTRES	17
FIGURE 2: THE HERSCHEL COMMON SCIENCE SYSTEM	20
FIGURE 3: THE HGS SMOOTH TRANSITION BETWEEN PHASES	21
FIGURE 4: THE HCSS DISTRIBUTION ACROSS CENTRES	23
FIGURE 5: THE HGS IN THE ROUTINE OPERATIONS PHASE.....	24
FIGURE 6: THE ABSTRACTION LEVELS OF THE CUS.....	26
FIGURE 7: THE HERSCHEL MOC SYSTEM	33
FIGURE 8: OVERVIEW OF THE COMMUNICATION NETWORK	35
FIGURE 9: REPRESENTATIVE MOC COMPUTER AND NETWORK CONFIGURATION FOR HERSCHEL.....	37
FIGURE 10: STANDARD SIMULATION INFRASTRUCTURE.....	41
FIGURE 11: SIMULATOR SOFTWARE STRUCTURE	41
FIGURE 12: MISSION PLANNING FLOW	42
FIGURE 13: THE DDS STRUCTURE	44
FIGURE 14: THE CONCEPT OF TELEMETRY DATA PROCESSING	49
FIGURE 15: THE HGS IN ILT	58
FIGURE 16: THE HGS IN IST	67
FIGURE 17: THE HGS IN COMMISSIONING PHASE.....	74
FIGURE 18: THE HGS IN POST-OPERATIONS PHASE.....	80

1 INTRODUCTION

1.1 *Scope and purpose*

This document describes the top-level design of the Herschel Ground Segment (HGS). The HGS mandate is defined in the FIRST Science Management Plan [AD-1] and is elaborated upon in the Herschel Space Observatory Operations Scenario Document [AD-2].

This document identifies the major systems and functional subsystems of the HGS and goes into some detail in the identification of the interfaces between these systems/ subsystems.

The document covers the HGS design for the following Herschel mission phases: instrument level tests (ILT), integrated system tests (IST), ground segment tests, in-orbit operation and post operation. In-orbit operations covers the launch and early operations phase (LEOP), commissioning, calibration/ performance verification, science demonstration and routine operations phases. A description of these phases can be found in [AD-2].

This document serves a number of purposes:

- To document the HGS top level design for all relevant parties, i.e. Project, the Herschel Science Centre (HSC), the Instrument Control Centres (ICCs) and the Mission Operations Centre (MOC),
- To identify the systems, functional subsystems and interfaces of the HGS,
- To identify the systems/ subsystems and interfaces which are to be reused over different phases of the Herschel mission in accordance with the concept of smooth transition (see section 2.1.3),
- To provide some insight into the physical design of the major HGS systems/ subsystems.

This document is intended for:

- The HGS managers who need to get a broad understanding of the HGS design.
- The HGSSE to identify interface requirements and ICDs between the HGS systems and functional subsystems.
- The architects of the different HGS systems in order to provide an understanding of the constraints placed by the entire HGS on their own system.

This document does not constitute the architectural design document of any of the HGS systems or functional subsystems.

This document is structured as follows:

- Section 2 introduces the operation concepts (2.1) and consequent design concepts (2.2) which drive the HGS design as a whole.
- Section 3 presents the HGS design for all of the Herschel mission phases which the HGS has to support, with a description of the main components and interfaces in each phase.
- Section 4 discusses the HW resources aspects (TBW)

1.2 References

1.2.1 Applicable documents

[AD-1] FIRST Science Management Plan (SMP), ESA/SPC(97)22, 20 August 1997.

[AD-2] Herschel Space Observatory Operations Scenario Document, FIRST/FSC/DOC/0114, Issue 1.2, 17 March 2003.

1.2.2 Reference documents

[RD-1] FIRST Operations Interface Requirements Document (OIRD), SCI-PT-RS-07360, Issue 2.0, 12 July 2001.

[RD-2] HCSS Glossary of Terms, FIRST/FSC/DOC/0120, Issue 1.1, 15 March 2001.

[RD-3] Telemetry and Telecommand Packet Utilisation Standard, ECSS-E-70/41, Draft 03, March 1999.

[RD-4] Packet Structure ICD, SCI-PT-ICD-7527, Issue 3.0, 2 April 2003.

1.3 Acronyms and Definition

The definition of acronyms for the HGS can be found in [RD-2] and accessed at

<http://astro.esa.int/SD-general/Projects/Herschel/hscdt/documents/index.html#ReqDoc>

2 SYSTEM OVERVIEW

2.1 *Operation concepts*

This section identifies the satellite tests and operations concepts that drive the HGS design. They are:

- Geographical distribution
- Satellite daily telecommunications period (DTCP)
- Smooth transition across ILT, IST, in-orbit and post mission phases
- Commonality between instruments

This section is largely an extract from [AD-2]. The operational concepts are presented here in order to make this document self-standing and easier to read.

2.1.1 Geographical distribution

During the in-orbit and post mission phases the HGS will be deployed over the following operational centres:

- The Mission Operations Centre (MOC). The MOC is responsible for all aspects of spacecraft operation as well as the safety of the instruments (in-orbit phase only). This includes:
 - Generating all commands to be uplinked to the satellite based on input from the HSC, the ICCs and the MOC's own subsystems.
 - Receiving, recording for safekeeping, consolidation of the telemetry data and making this telemetry data available to the rest of the HGS.
 - Ensuring the health and safety of the satellite and all its subsystems, including that of the science instrument complement.
 - Maintaining the instrument and spacecraft databases shared by the MOC, ICCs, and HSC.
 - Maintaining the SCOS-2000 system used by the MOC and the ICCs.
- The Herschel Science Centre (HSC) is the single -point interface to the outside world for all Herschel observatory matters. In particular, it is responsible for:
 - Issuing calls for observing time proposals, and the handling of proposals.
 - Providing general community support throughout all mission phases, acting as single-point input.
 - Giving support to ESA Public Relations and science communications activities.
 - Coordinating cross -calibration between the Herschel instruments, and between Herschel and other facilities.
 - Performing detailed scientific mission planning.
 - Providing quality control information on all observational data.
 - Providing, managing, and maintaining the central Herschel database, and all the HSC software subsystems,
 - Populating the Herschel database with characterisation, science, and operational data,

- Providing the framework and the interfaces with the astronomer for all community interaction, e.g. for information gathering, proposing, data browsing and retrieval, on-demand data processing, and generation of quick-look products,
- Ensuring overall ground segment consistency with respect to instrument configuration, including the instrument on-board software,
- The Instrument Control Centres (ICC, at least one centre per instrument) are responsible for the successful operation of their respective instruments, and for making possible the processing of the resulting data. The ICCs are responsible for most instrument related operational issues; instrument monitoring and calibration, developing and maintaining instrument specific software and procedures, and supporting instrument operations. Each ICC performs tasks dedicated to their particular instrument. In particular the responsibilities include:
 - The monitoring of instrument development, testing, characterisation and calibration.
 - Status and health monitoring, and maintenance of the instrument.
 - The provision to the HSC of instrument ‘time estimators’ and command generation facilities.
 - The maintenance of the instrument on-board software that has been generated and validated by the instrument teams.
 - The provision of all software required for error correction, calibration, and generally for the scientific processing of the data from the instruments, including interactive analysis tools and scripts and/ or ‘recipes’ allowing the generation of ‘standard’ data products.
 - Instrument calibration i.e. all aspects of the instrument calibration during all phases of the mission.

The HGS is decentralised. The assumptions are that the MOC will be located at ESOC, and the ICCs at (or near) the PI institutes while the HSC will be located at a suitable location in an ESA member state, e.g. Vilspa (Spain).

The HGS operational centres and their interfaces are presented in the Figure 1. The figure introduces the notion of consolidated telemetry, near real-time (NRT) telemetry and the ICC@MOC operational centre. These terms are explained in section 2.1.2 below.

2.1.2 Satellite daily telecommunication period (DTCP)

A spacecraft operational day (OD) is defined to be 24 hours. The ground coverage of the spacecraft during an OD will be limited to a few hours (nominally 3 hours in the routine operations phase). This period of ground contact is referred to as the daily telecommunication period (DTCP). When out of ground contact, the spacecraft will record all of the spacecraft and instruments telemetry on solid state mass memory. The recorded telemetry of the last (OD) will be downloaded during the DTCP. During this period, the spacecraft will also transmit the live spacecraft and instruments telemetry.

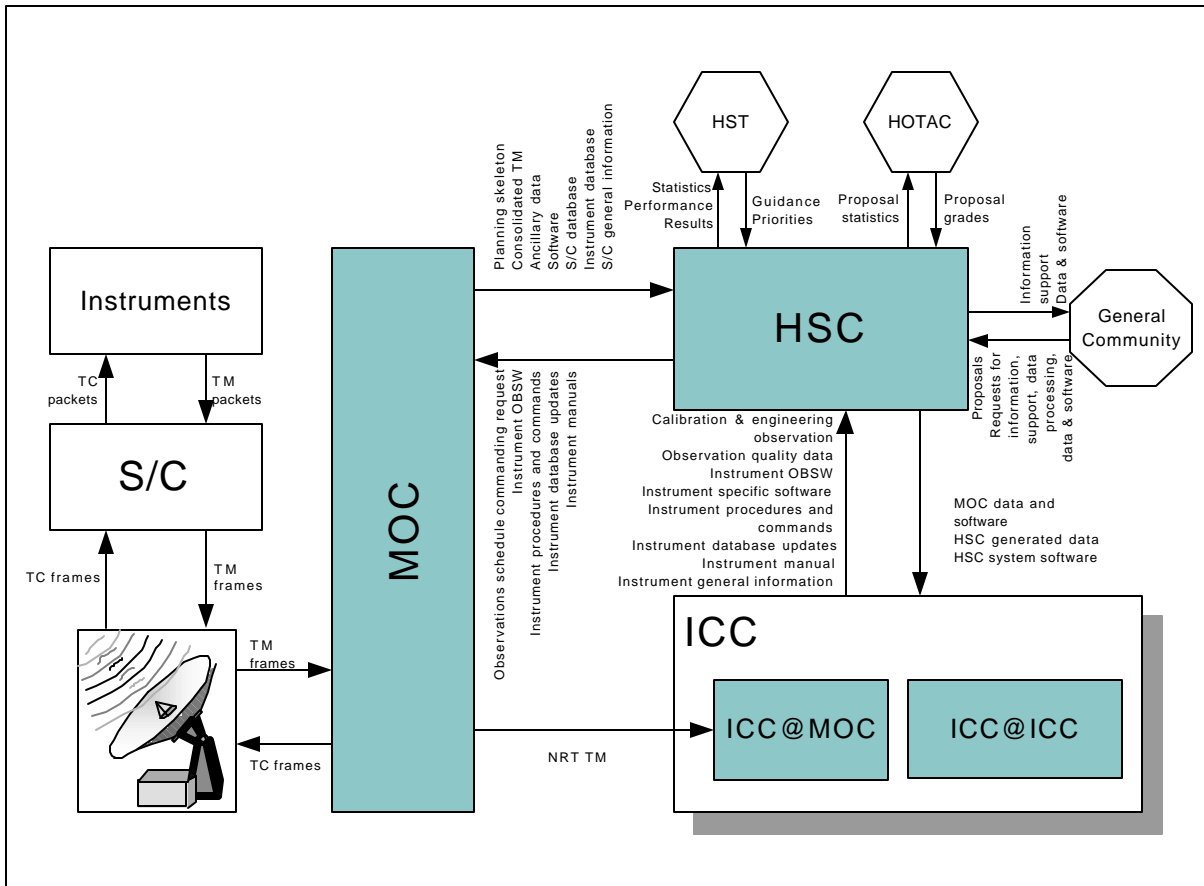

Figure 1: The Herschel Ground Segment Centres.

Consequently, during a given DTCP the spacecraft will transmit to MOC (via the ground station) four different telemetry data flows which are summarised in the following table:

Live HK TM	HK TM generated during the DTCP and downloaded live
Live Science TM	Science TM generated during the DTCP and downloaded live
Dump HK TM	HK TM generated during the previous OD and downloaded during DTCP
Dump Science TM	Science TM generated during the previous OD and downloaded during DTCP

The MOC will make available the telemetry received from the ground station in NRT (i.e. with a delay limited to the time needed by MOC to relay a telemetry packet) and later in a consolidated form.

The consolidation of telemetry takes place over a period of time. Consolidated telemetry data will be guaranteed by MOC to be:

- Complete and transmission error free over the consolidation period (to the extent that the telemetry data have been successfully received on the ground, i.e. data lost in the space/ ground link will not be recovered),

- (On-board generation) time ordered.

For all instrument calibration that can be carried out offline and for science activities, the ICCs will normally work from consolidated telemetry. The HSC is expected to work exclusively from consolidated telemetry.

For instrument operation purposes, the ICCs will be interested in monitoring the live telemetry of their own instruments in NRT during certain phases of the mission (commissioning) or following emergencies.

For NRT telemetry monitoring to make sense, it should be associated with the possibility for the ICCs to command their instruments in real-time, i.e. during the period of ground coverage. Real time commanding of an instrument will only be possible from the MOC mission control system which leads to having the ICCs real-time operations located at the MOC (ICC@MOC).

Consequently, the following types of telemetry data flow originating from MOC need to be considered:

Near Real Time (NRT) TM data flow	TM distributed as is and as soon as received by MOC. It includes both live TM (HK and science) and dump TM (HK and science).
Consolidated TM data flow	TM made available after consolidation over a period of time. spacecraft HK, instruments HK and science can be consolidated separately.

2.1.3 Smooth transition across mission phases

To facilitate the transfer of knowledge and procedures, as well as for reducing conversion efforts, it is very desirable to have the same (or at least a similar) environment through all Herschel mission phases from ILT to post operations.

In the ILT phase, the instrument teams will be performing the first characterisation of their instruments. In the subsequent IST phase, the integrated satellite system will be tested. In both phases a special test set-up will be created to command the spacecraft (IST only), the instruments and the test environments. The commanding and the handling of the test outcomes in ILT shall closely resemble the final operational environment. The ILT and IST set-up should subsequently smoothly adapt into the in-orbit phase operations environment.

The in-orbit phase operational environment related to the HSC and the ICCs is then expected to support, largely as is, the post mission phase. In particular the science and instrument calibration data should be made available to the science community, using the in-orbit phase operational environment.

2.1.4 Commonality between instruments

Commonality between instruments may simplify the design of the ground segment, especially during the different test phases where the instruments are more directly connected to other components in the ground segment without being shielded by the spacecraft command and data management subsystem (CDMS).

The three Herschel instruments share the following:

- The way they are commanded, i.e. the three instruments follow the packet utilisation standard (PUS) [RD-3] telecommand format [RD-4] and the telecommand database structure, and
- their telemetry format (PUS telemetry format [RD-4]).

This in turn allows common development of the ground segment infrastructure in terms of instrument test facilities, the so called electrical ground segment equipment (EGSE-ILT and Instrument-EGSE) and in the Herschel common science system (HCSS) as far as the instrument commanding and the interfaces with the EGSE-ILT are concerned.

2.2 *The Herschel Ground Segment design concepts*

2.2.1 Introduction

At the highest level, the HGS is split into a number of systems, which interface with each others in order to support the HGS operation from ILT phase to post mission phase.

The systems are the following:

- the Herschel Common Science System (HCSS) which supports the functions common to instrument and science operations from ILT phase to post-mission phase. (see section 2.1.3).
- the MOC System which supports the MOC operations,
- the ILT Electric Ground Support Equipment (EGSE-ILT) which supports the test executions in ILT,
- the Central Checkout System (CCS) which, together with Instrument-EGSE (derived from the EGSE-ILT) supports test execution in IST.,
- the Real Time Analysis (RTA) system which complements the HCSS in the area of instrument housekeeping telemetry real-time analysis.
- the On-board Software Maintenance (OBSM) system which complements the HCSS in the area of instrument on-board software maintenance.

Each of these systems and their interfaces during the different mission phases will be described in section 3. This section will further detail these systems only to explain how they support the two main HGS operational concepts: smooth transition across phases (see section 0) and geographical distribution (see section 2.2.4)

The HCSS is key to supporting these operational concepts.

2.2.2 The Herschel Common Science System (HCSS)

The HCSS groups all HGS functionalities that are common to the science and instruments operations. It includes the major following functions:

- Definition of proposals and observations
- Scheduling of observations
- Observations commanding generation

- Analysis of the instrument science data
- Processing and quality assessment of observation science data
- The storage and retrieving of all instrument and science relevant data

Each of these major functions is implemented by an HCSS subsystem or component. The HCSS includes the following subsystems:

- Common uplink system (CUS): Allows definition of observation templates and observation commanding generation for all 3 instruments.
- Proposal handling system (PHS): Allows definition of proposals and observation requests for all 3 instruments.
- Mission planning system (MPS): Allows scheduling of observations for all 3 instruments.
- Configuration control system (CC): Allows configuration control of HCSS data, software and documentation.
- Database browsers: Allows browsing of the data in the HCSS archive.
- Interactive analysis (IA): Allows interactive analysis of the observation data produced by an instrument.
- Quick look analysis (QLA): This is a subset of IA used by the ICCs. It allows a quick look assessment of data from science and tests observations
- Standard product generation/ Quality control processing (SPG/ QCP): This is a subset of IA used for producing standard data products and performing quality assessment for observation science data.

At the heart of the HCSS is an object-oriented database management system (ODBMS) for storage and retrieval (querying) of all the Herschel mission artefacts relevant to science and instrument operations. This ODBMS will act as a data server for each of the HCSS subsystems defined above as well as for RTA and the OBSM. All of the above HCSS subsystems will interact directly with the ODBMS or via specific object servers to retrieve and/ or store their input and output data.

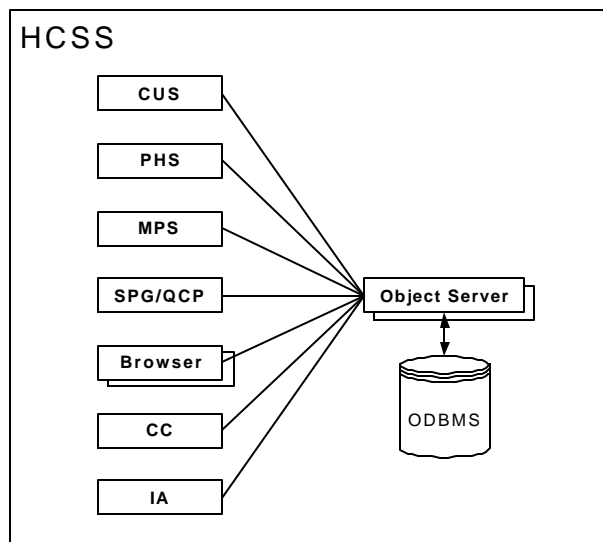

Figure 2: The Herschel Common Science System.

The HCSS is represented in Figure 2 above. A more detailed description of each of these components can be found in section 3.1.2.

2.2.3 Smooth transition across mission phases

The smooth transition concept applies to the common science and instrument part of the HGS, i.e. the HCSS, RTA and the OBSM. Smooth transition between phases means that:

- 1) Software developed for a given phase can be largely reused in the following phase (software compatibility).
- 2) Data collected in a given mission phase can still be accessed and processed in the following phases (data compatibility).

Bullets 1) and 2) above point to a compatibility in the data produced/ consumed by the HCSS across the different mission phases and, by extension, to a compatibility in the data (and their format) exchanged between the HCSS and the rest of the HGS during the ILT, IST and in-orbit phases, i.e. compatibility of the data exchanged with respectively the EGSE-ILT, Instrument-EGSE and the CCS and the MOC system. This concept is depicted in Figure 3 below. It shows that the HCSS subsystems are reused across the different mission phases. Conceptually the only functions of the HCSS that are subject to changes are the ones dealing with the import/ export of data from/ to the other systems. Providing that data relevant to different phases are produced with the same content and format, the archiving and retrieval of these data in the HCSS/ ODBMS can be kept mission phase independent.

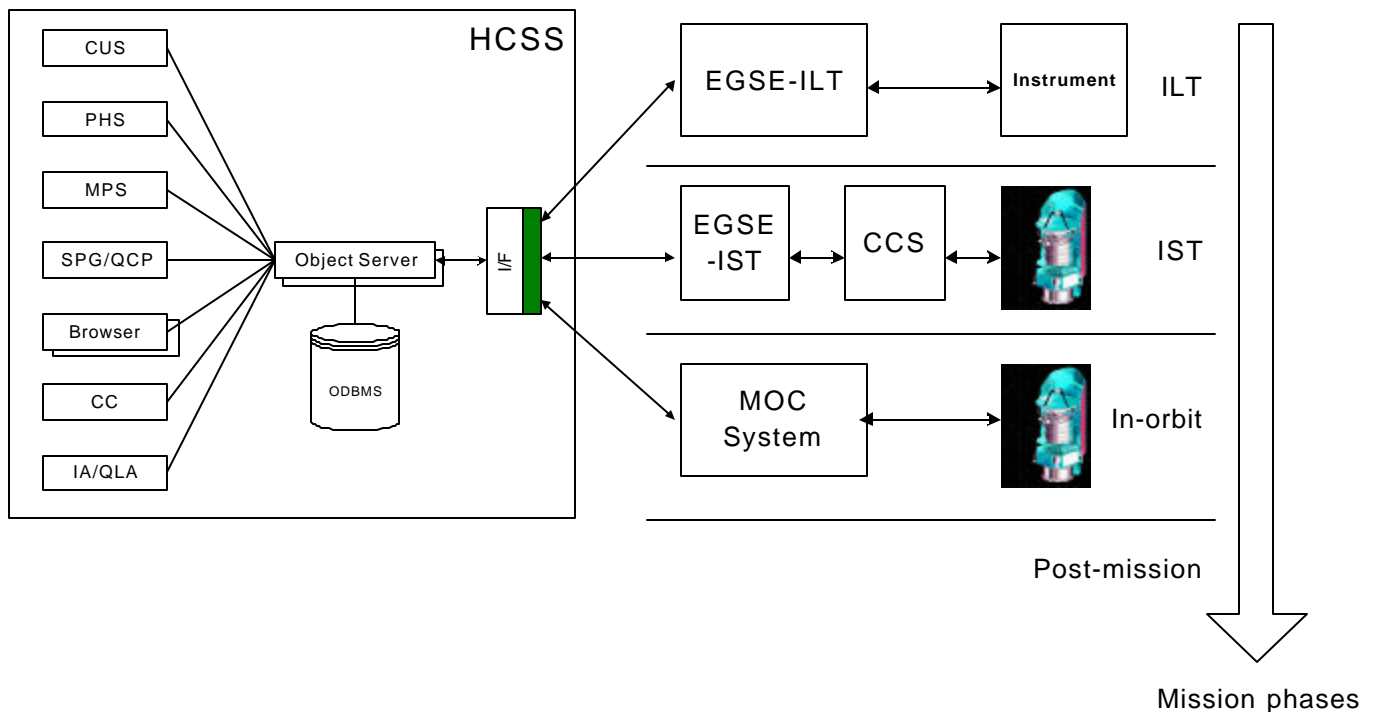

Figure 3: The HGS smooth transition between phases

The basic data flowing between the HCSS and these systems are 1) commands (instrument commands, spacecraft commands or test environment commands) exported from the HCSS and 2) telemetry and ancillary data received by the HCSS.

The data compatibility across phases then points to the following:

1) The commanding in the context of the ILT and IST phases should be compatible with the commanding in the context of the in-orbit phase. In both cases, commanding (except manual commanding) will proceed from observations defined using the CUS (see section 3.1.2.1). Observations in ILT and IST will cover the commanding of the test environment (EGSE-ILT or CCS) as well as the commanding of the system under test (instrument).

2) The telemetry and ancillary data collected in the different mission phases shall be compatible. Practically, this means that:

- telemetry produced by the instruments, the spacecraft and the test environment in ILT and IST follow the ESA telemetry standard format.
- Ancillary data produced by EGSE-ILT, CCS or the MOC system for the same purpose (e.g. telecommand history) have the same content and follow the same format.

This point is partially guaranteed by the fact that the EGSE-ILT, the CCS and the MOC system shall all be SCOS-2000 based.

Although data compatibility will be sought from the start of ILT, it is most likely that the data format (e.g. source data in telemetry packets) will change from one phase to another or within a phase especially for ILT. For this purpose, it is important that the HCSS/ ODBMS supports the access to data in the old format or the reformatting of the data (see HCSS in section 3.1.2.9).

2.2.4 Geographical distribution across different centres

For the ILT, in-orbit and the post mission phases, the HCSS will be deployed in the HSC and in the different ICCs. The HSC and the ICCs will share, through the HCSS, the same applications (HCSS subsystems) and the same data. The distribution of the data and the applications across the different centres is supported by the HCSS. Conceptually, the HCSS/ ODBMS can be seen as one single database that can be accessed from the HSC and the different ICC centres.

In each of the operational centre, there will be a HCSS node which will hold and serve local data and which will support remote access of data at any of the other HCSS nodes in a transparent manner. Therefore, any HCSS subsystems at any operational centre will be able to access in the same and transparent way all HCSS data, local or remote. This concept of distributed client/ server architecture is presented in Figure 4 below. This figure shows the HSC and the three ICCs for the three Herschel instruments. This will be the standard configuration supported by the HSC. It does not exclude that the HCSS can be deployed in other centres, e.g. additional instrument centres, however this shall be transparent to the HSC. One example of additional centres is the commissioning phase where the HCSS will be deployed in the ICC@MOC (see section 3.6).

The figure shows also that only part of the HCSS can be deployed in a given site depending on the operational responsibility of the site. For example, the QCP is not deployed in the ICC while the QLA is not deployed in the HSC.

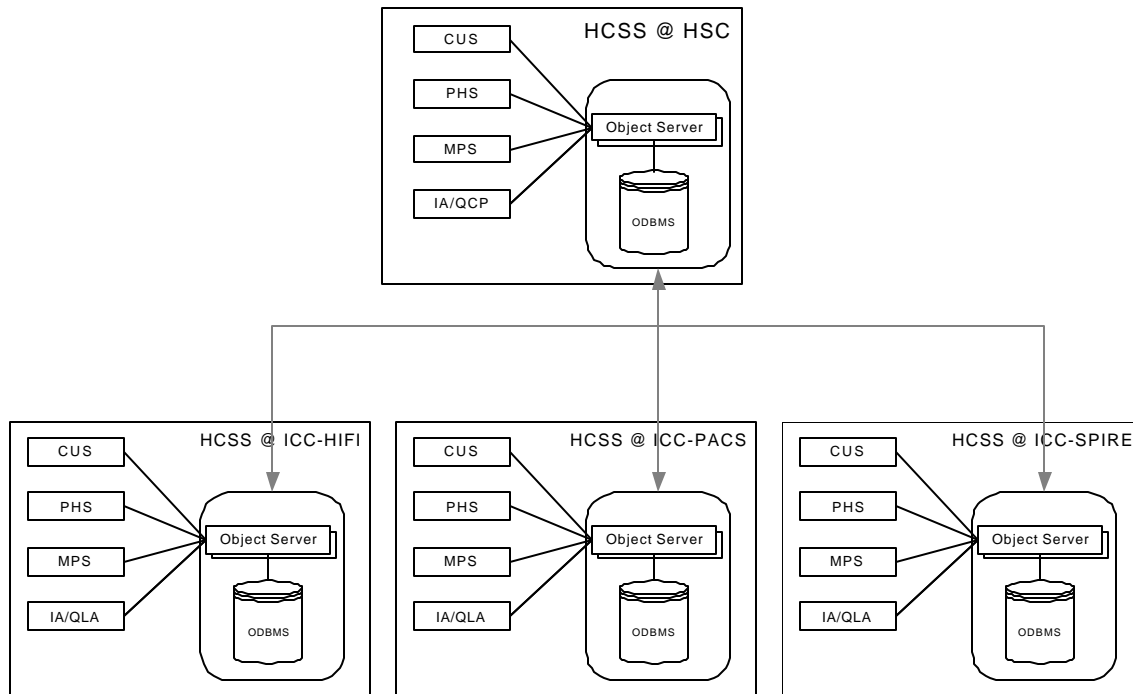

Figure 4: The HCSS distribution across centres

3 SYSTEM DESIGN

This section describes the HGS in term of its centres, systems, and subsystems (or components) for the different phases of the mission with a particular focus on the data interfaces between the systems and/ or between the centres.

It documents how the HGS will evolve across the different mission phases and in particular identifies those functional subsystems and data interfaces that are common to the different phases of the mission (smooth transition). The routine operations phase system design is described first, because the system design in the other phases is derived from the routine operations phase set-up.

3.1 Routine operations phase

3.1.1 Introduction

In the routine operations phase, the HGS will be composed of the following systems, the MOC System, the HCSS, RTA, OBSM and MIB editor. The HCSS will be deployed at the HSC and at the three ICCs. The HCSS may also be deployed at instrument centres other than the three ICCs, this is however considered an architectural consideration internal to the ICCs and is out of scope of this document.

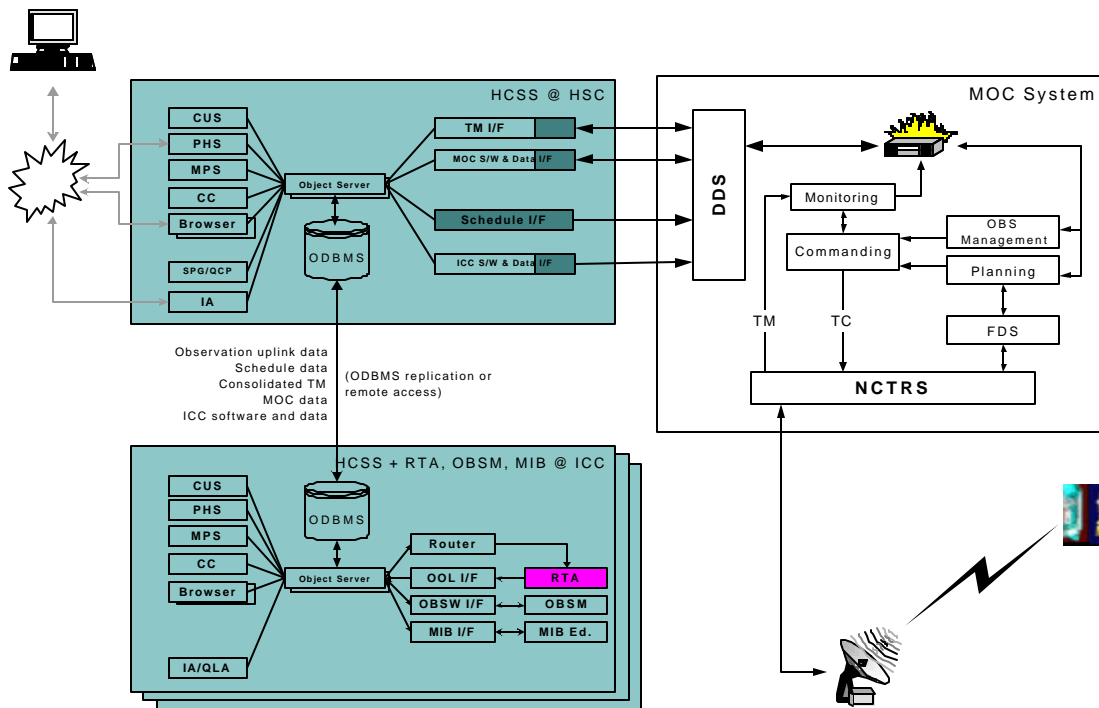

Figure 5: The HGS in the routine operations phase

The HGS for the routine operations phase is presented in Figure 5 above. In cases of (instrument) emergencies, the HGS will be extended with an additional centre, the ICC located at the MOC (ICC@MOC), to handle real-time operations. This extended set-up, which is a subset of the set-up to be operational in commissioning phase, is described in section 3.6

3.1.2 HCSS components

3.1.2.1 Common Uplink System (CUS)

3.1.2.1.1 The CUS concept

The Common Uplink System (CUS) concept is based on four levels of abstraction, which are described in Figure 6 below. All instrument uplink procedures should be defined using this stack of abstraction levels.

The **observation** level defines the scientific, calibration or engineering observation and its associated parameters. This level represents the common entry point for all users who wish to submit requests for observations with Herschel (astronomers, instrument specialists and calibration scientists). They will use the Proposal Handling System (PHS) (see section 3.1.2.2) where an observation mode can be selected and parameters specified in a user-friendly environment. This abstraction level will typically also define scheduling constraints or instructions.

The **observation mode definition** contains the definition of the observation defined e.g. in a typical scripting language. It defines how the observation type and parameters should be translated into a sequence of observation building blocks. During such a translation, all input can be checked for correct syntax and parameter range and validity.

The **observation building blocks** are the next level of abstraction. This is used to define how the observation is functionally structured as a sequence of measurement 'steps'. It corresponds to a high level description of the observation in the user domain, typical building blocks are e.g.

```
do_dark_measurement    or    perform_scan(start, stop) .
```

The building blocks are defined in the **building block definitions**, which are specified in the same way as for the observation mode definition, i.e. using a scripting language. The definition specifies how the building blocks should be translated into a sequence of command mnemonics. Since observation building blocks can also take parameters, the translation step performs parameter validity and range/ limit checks next to syntax checking.

The next abstraction level is then a sequence of **relative time-tagged telecommand mnemonics**. These are instrument commands (or EGSE commands, see ILT section). Instrument commands correspond to an on-board function or on-board control procedure (OBCP) or to a more fundamental instrument command that needs no further expansion/ translation by the instrument DPU/ ICU. The difference between this abstraction level and the observation building blocks (OBBs) is somewhat artificial since OBBs could also be defined as

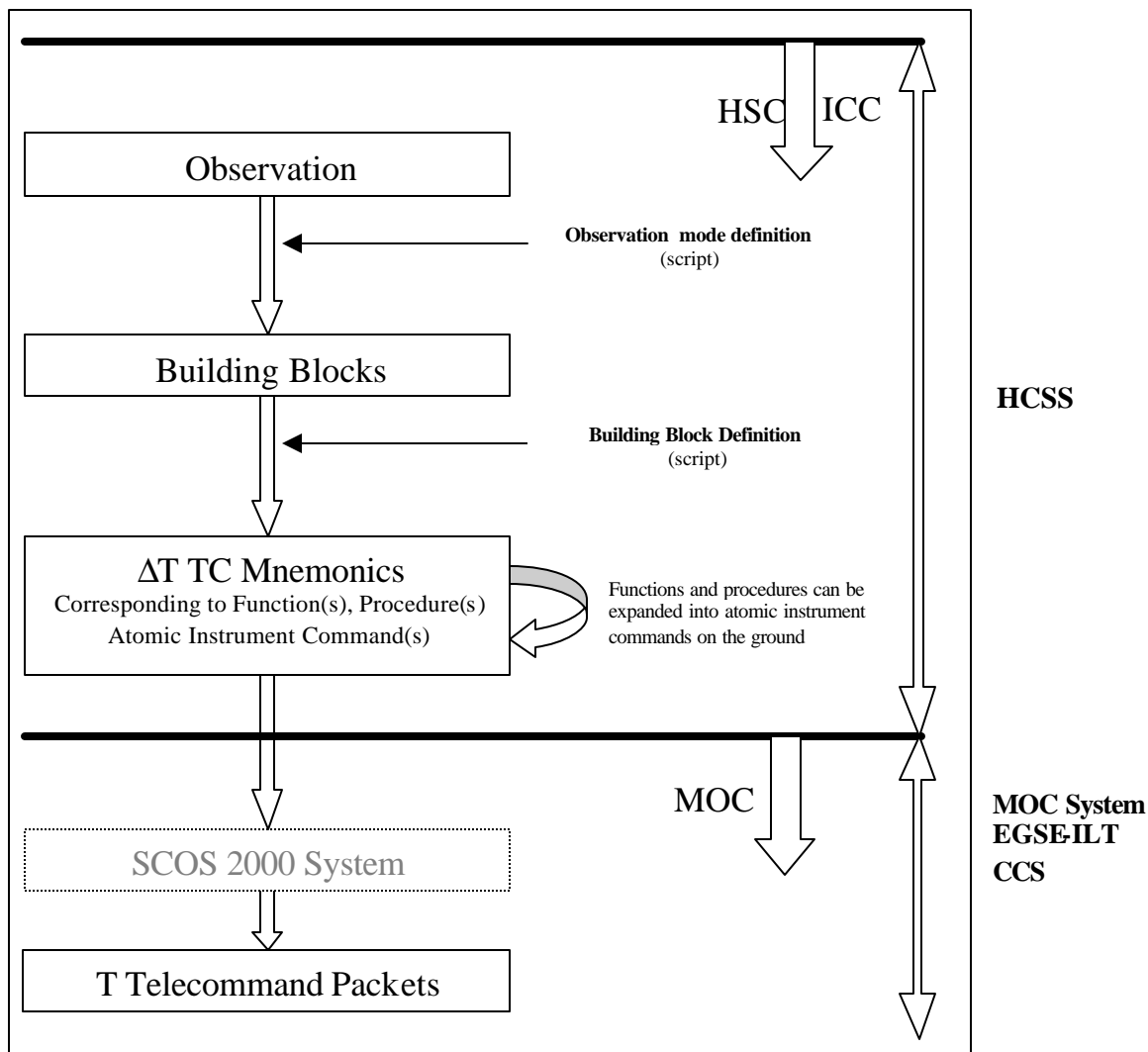

Figure 6: The abstraction levels of the CUS

OBCPs. From the user or developer point of view this difference is nevertheless important since (1) observation building blocks are defined in the user domain whereas OBCPs are defined in the instrument domain, and (2) data reduction algorithms may benefit if the downlink (telemetry) organisation (data model) is based on observation building blocks.

On-board functions and OBCPs are normally expanded on-board by the DPU/ICU and provide a way to optimise or minimise the uplink telecommand stream and thereby cope with the limited uplink data rate. It is nevertheless necessary that these OBCPs can also be expanded on the ground into a sequence of fundamental or atomic instrument commands for testing and engineering purposes. The first three levels in this stack are part of the HCSS. This part of the CUS concept is identical for all mission phases (smooth transition).

In the routine operations phase the sequence of telecommand mnemonics is handed over to the MOC and translated into a sequence of telecommand packets ready for uplink. In ILT and IST the translation of telecommand mnemonics into telecommands will be performed by respectively the EGSE-ILT and the CCS (sections 3.2 and 3.3). In all three cases, the conversion will be supported by SCOS-2000 (as the EGSE-ILT, the CCS and the MOC system will all be based on SCOS-2000).

3.1.2.1.2 *The CUS component*

The CUS component will allow instrument specialists to create and update observation modes and building blocks definitions. A scripting language supports the definition of modes and building blocks. In the routine operations phase the observation mode definition is then used as input by the PHS to allow users to define an observation.

The CUS will allow the definition of observation modes and building blocks in the same way for a general user observation, a calibration observation or an engineering observation.

The CUS will be used during instrument testing (ILT + IST) for the generation of instrument test sequences and calibration and instrument characterisation measurements as input to the EGSE or CCS Test Control system.

The CUS component will be identical for all three instruments on Herschel (commonality).

3.1.2.2 *Proposal Handling System (PHS)*

In essence, the PHS will support the definition and submission of proposals and observations based on observation modes as previously defined with the CUS. In the process of defining observations within the PHS information about the building blocks composing a given observing mode will be available to the user to aid him in understanding how the observation will be executed.

As the CUS defines observation modes and observation building blocks for all type of observations (science, calibration, engineering) in the same way, the core PHS will be designed to support the definition of all these observation types.

The main outputs of the PHS are so-called observation requests, which are inputs to the MPS (see section 3.1.2.3). An observation request will capture all the information needed for the observation to be executed. The PHS will provide the user interface (UI) supporting the capture of this information. The observation requests will be stored into the HCSS/ ODBMS by the PHS.

On top of this core functionality, the PHS will allow the validation of the observation definition parameters (to the extent that the parameters validity domains are defined in the observation template) and will allow, using HCSS observation object core services, to compute the duration of an observation.

In summary, in the routine operations phase, the PHS will support the following activities:

- Create and update scientific, calibration and engineering proposals
- Create and update observation requests

- Fill-in observation request templates
- Estimate 'observing times'
- View observation building blocks for observations
- View instrument commands for observations
- Submit observations for scheduling
- Grading observations/ proposals
- Managing observation scheduling priority

In the routine operations phase, the PHS will be accessible locally at the HSC for the proposal handler to update/ modify proposals and observations, locally at the ICC for the instrument engineers and the calibration scientist to define and submit engineering and calibration observations and remotely by the astronomers to define and submit scientific observations.

The HCSS will support remote access to the PHS at the HSC, using e.g. WWW technologies and public network.

3.1.2.3 Mission Planning System (MPS)

In essence, the MPS will support 1) the elaboration of a schedule (or sequence) of observations from observation requests as defined by the PHS and 2) the generation of the commands corresponding to the scheduled observation using HCSS observation object core services. The schedule information will be stored into the HCSS/ ODBMS.

The MPS schedule elaboration will take the following constraints into account:

- The satellite operational constraints as defined by MOC in the planning skeleton (see section 3.1.8.3).
- The spacecraft attitude constraint as defined by MOC (see section 3.1.8.3).
- Spacecraft slew time and path predictor software and data as defined by MOC (see section 3.1.8.3).
- Instrument inherent constraints .
- Observation time constraints as defined by the observer.

The MPS will schedule observations at absolute time, based on absolute observation time windows given in the planning skeleton. The commands generated by the MPS will correspond to spacecraft commanding requests and instrument telecommand mnemonics. Instrument telecommand mnemonics will be generated using the HCSS observation objects core services. The instrument commands will be generated as a sequence of telecommand mnemonics with time tagged relative to the start of the observation. The sequence will then be incorporated in the schedule and relative time tagged will be translated into absolute time.

The schedule will be exported to MOC (see section 3.1.8.5) for further processing, uplink and eventually on-board execution (see MOC mission planning in section 3.1.3.6).

The MPS will support the multiple scheduling (and therefore execution) of an observation request. In effect, the MPS will create an instance of an observation, each time an observation request will be scheduled. The observation instance will be stored in the HCSS. The telemetry resulting from the observation execution will then be linked to this instance of the observation (see telemetry archiving in section 3.1.8.2). For this

purpose, the MPS will generate as part of the instrument commands related to an observation, telecommand mnemonics carrying the observation instance identifier (ObsId) and observation building block instances identifier (BbId). These telecommands will be decoded by the instruments and will allow the instruments to tag their telemetry with the current ObsId and BbId allowing in turn the linking of telemetry to the corresponding observation and building block instances.

In summary, in the routine operations phase, the MPS will support the following activities:

- The creation of observation schedules
 - in manual or automatic mode
 - taking into account constraint handling
 - with optimisation (automatic mode only)
- The creation of observation and building block instances for scheduled observations with unique ObsIds and BbIds.
- The generation of telecommand mnemonics corresponding to scheduled observations.
- Perform long term planning.

In the routine operations phase, the MPS is to be used by the mission planner locally at the HSC. The ICCs will use the MPS to prepare and update the PV phase schedules. In the routine operations phase MPS will also be used to investigate the impact of instrument mode updates on scheduled observations.

3.1.2.4 Standard Product Generation/ Quality Control Processing (SPG/ QCP)

The SPG/ QCP will support the reduction of the science data associated with a science observation. It serves two purposes:

- 1) The generation of quality data for a science observation allowing to assess the quality of the science data.
- 2) The generation of standard science products attached to the observation.

The SPG/ QCP is expected to be based on the same core data reduction modules as the astronomer IA software, see section 3.1.2.7, but will feature a specific user interface to allow for easy standard processing of the observations data.

The SPG/ QCP will be used in batch mode or in interactive mode (on-demand processing).

The SPG/ QCP will be used by the HSC operations team and remotely by the astronomers to perform on-demand processing. The HCSS will support the remote access to the SPG/ QCP at the HSC, using e.g. WWW technologies and the public network.

3.1.2.5 Configuration Control System (CC)

The Configuration Control System (CC) will support the definition and control of configurations of data (including documentation) and software relevant to the HCSS. Versioning of data will be handled through object versioning and the versioning as defined within the HCSS (see section 3.1.2.9). Versioning of software is ideally done through the same system because this makes it much more transparent to the users of the system and simplifies maintaining all associations between software and data. The CC shall in any

case allow to build configurations mixing data and software, so as to maintain the consistency between the versions of the data and the versions of the software used to create the data or which can be used to process the data.

The CC will include an SPR/ SCR system allowing identifying and tracking changes between different software and data configurations.

3.1.2.6 Archive Browsers

The archive browsers will support the navigation through and access to data stored in the HCSS ODBMS. The browsers will have a graphical user interface (GUI) to browse the data and will support data queries in a dedicated language (see section 3.1.2.9).

It is expected that different browsers will be developed to match the specific needs of the different types of HCSS users. Some browsers will be accessible remotely to allow astronomers to browse and access authorised data at the HSC. The HCSS will support the remote access to browsers at the HSC, using e.g. WWW technologies and the public network

3.1.2.7 Interactive Analysis (IA)

Instrument specialists will use IA to analyse telemetry stored in the ODBMS to further their understanding of the instrument and its operations and to generate calibration parameters.

For updates to calibration parameters change request will be issued such that after generation and verification the updated parameters can be made available for use in the standard processing algorithms (see section 3.1.2.4).

Astronomers will use the IA algorithms to generate calibrated data from the raw telemetry and to further analyse these data to obtain scientifically useful parameters. IA can be used remotely via a WWW interface or can be downloaded and installed locally for offline processing. Archive browse functions can be used from within IA to select particular types of data (e.g. particular types of observations, particular types of scientific sources, particular observation building blocks etc.) for analysis. Subsequently the different available IA algorithms will be used to process these data. Specific display routines will be used to visualise (intermediate) processing results.

It should be noted that initially (especially in the development and the early in-orbit phases) IA will be fully optimised only for performing instrument behaviour analysis and calibration. Optimisation and the addition of facilities to perform astronomical analysis will come at the later stages.

Ideally the IA for astronomers (used by the general community) and the IA for instrument specialists (used for e.g. calibration) will share the same infrastructure and implementation.

3.1.2.8 Quick Look Analysis (QLA)

QLA is intended to monitor the instrument status and provide the opportunity for a quick assessment of the success or failure of an observation. QLA is used for monitoring basic parameters mainly from science telemetry.

QLA is expected to be implemented as a subset of IA (expert IA). Its main use is to support instrument testing during the ILT and IST phases.

3.1.2.9 *The HCSS core services and the ODBMS*

The HCSS ODBMS will store all HCSS produced artefacts (e.g. observing mode definitions, observation requests, observation instances, schedule, calibration data, data products) as well as the telemetry and ancillary data retrieved from the MOC. The HCSS will also provide the mechanisms to link stored artefacts with relevant documentation and the (version of the) software used to produce the artefacts.

Artefacts will be stored as objects in the HCSS ODBMS. The HCSS object server will allow the retrieval and storage of objects from the HCSS subsystems as well as core operations on object data (see below).

As already mentioned in section 2.2, the HCSS is key to the implementation of the geographical distribution concept (see section 2.2.4) and the smooth transition between mission phases concept (see section 0). The concept of geographical distribution is expected to be supported by the HCSS ODBMS in the following way:

The data distribution across centres (i.e. concept of one single logical database for the HSC and the ICCs) is expected to rely largely on the ODBMS replication and remote access services. Replication allows for objects to be pushed automatically from the site where they have been created to other sites (at the time of creation or at regular time intervals) therefore making them accessible locally at these sites. Remote access allows for objects to be pulled from the site where they have been created when accessed from a remote site.

For the HCSS, it can be expected that data will be stored primarily where the data is produced or first imported and will be replicated to other sites, if these sites make “heavy” use of these data. Otherwise these sites data will remotely access from the data. For instance, during the in-orbit phase it can be expected that telemetry data of a given instrument that will be primarily stored at the HSC will be replicated at the corresponding ICC site. The decision to replicate data or not across centres will be made to optimise the data access performances and the load on the communication lines between centres. Data will flow between the different centres (HSC and ICC main centres) through dedicated communication lines that will be set-up for the duration of the in-orbit and post mission phases. The sizing of the communication lines between the centres is further discussed in section 4.

In terms of the smooth transition concept, the HCSS ODBMS will support the evolution of data format, which are likely to occur along the Herschel mission. This is expected to be supported in two ways:

- 1) *Reformatting of data* : Data created in a given format will be reformatted to match the new format. The HCSS ODBMS “schema evolution” feature is expected to provide some support in this area.
- 2) *Access to old format data* : The HCSS will maintain the relation between the versions of the data and the versions of the software which created the data as well as the versions of the software which can be used to process the data. This will allow data in old format to be accessed and reprocessed later in the mission.

On top of this, the HCSS ODBMS will have the following standard features to support the HCSS:

- *Storage/ retrieval of object relationships*: The object relationships (e.g. link between an observation instance and its corresponding telemetry) are expected to be stored in the ODBMS.
- *Multi-users access*: The HCSS database shall be accessible by multiple users in parallel. This calls for some locking mechanism at the ODBMS level to ensure the HCSS data consistency. External users (i.e. astronomers external to HSC or ICC) are not expected to access the ODBMS directly so as to control and limit (in numbers) their access to the database.
- *Object query languages* to support browsing.
- *Notification*: It shall be possible to automatically notify users on the occurrence of a given event (e.g. upon execution of an observation request, the astronomer owner of the request can be notified).

The HCSS will offer a set of object core services to the various HCSS clients in particular services related to observations. Instantiation of an observation, generation of the telecommand mnemonic sequences corresponding to an observation, computation of 'observing time', retrieval of telemetry related to an observation or a building block will be implemented as part of the HCSS infrastructure. Other core services from the HCSS are:

- *Object versioning* : It shall be possible to have different versions of an HCSS artefact stored in the ODBMS. Linked with the configuration control system (see section 3.1.2.5), this will allow for the definition and storage of data configurations.
- *Test environment or Sandbox*: HCSS support is expected for creating test environments, so that software testing can be carried out, without altering the data in the operational database.
- *Security* : It shall be possible to restrict the access to the HCSS database according to user name and groups (e.g. an observation request shall only be accessible to the astronomer who owns the request and to HSC/ ICC personnel).

All HCSS components will be direct clients of the HCSS ODBMS. These applications will heavily use the HCSS core services and directly manipulate objects that will be stored/ retrieved in/ from the ODBMS.

3.1.3 MOC system components

The MOC design concept has been defined taking into account [AD-1], [AD-2], the mission definition and preliminary space segment design.

The MOC consist of the following elements:

1. LEOP and routine operations phase Ground Station Network;
2. Mission Control Centre;
3. Mission Control Centre to HSC and ICC communications;
4. Mission Control Centre to System Validation Test (SVT) site communications;
5. Mission Control Centre to Centre Spatial Guyanais (CSG) communications.

Figure 7 shows the overall system configuration.

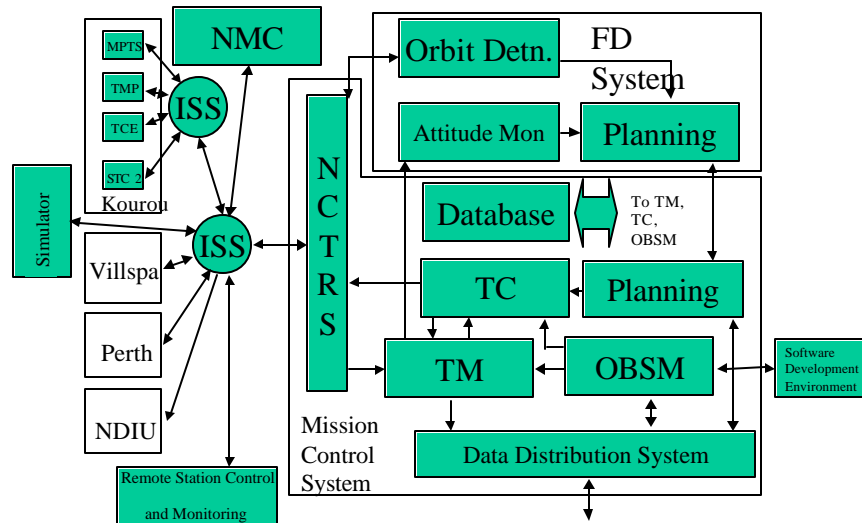

Figure 7: The Herschel MOC System

3.1.3.1 Ground Station Network

3.1.3.1.1 Ground Station Network Description

The prime station for Herschel operations will be the Perth 35m station. The ESA S-Band LEOP Stations Kourou and Villafranca will support the LEOP. The network will be configured for the Herschel and Planck satellites and commissioned starting from L-3 months. The ESOC Portable Simulator system will be configured for Herschel to act as a telemetry source and telecommand sink at the ground station.

The Perth 35m antenna will be able to receive simultaneously right and left hand circular polarized signals in 2 GHz (S-band) and 8 GHz-band (X-band) and in addition will be able to transmit signals with either right or left hand circular polarisation in 2 GHz and 7 GHz band, simultaneously to reception. The antenna is already prepared to be upgraded later for Ka-band (32 GHz band) reception. All specified performances can be met with program tracking, however Ka-band auto-tracking can be added optionally.

The overall mechanical/ RF concept is a Turning Head (TH) structure with an integrated Beam Wave Guide (BWG) feeding concept. The TH structure provides good reflector surface and pointing accuracy in all operating conditions including wind disturbances and minimises thermal effects compared to a Wheel and Track design. The BWG design with solid and dichroic mirrors allows for optimisation of illumination, efficiency, gain, and sidelobe performance for each band and permits simultaneous operation in all specified bands. With this concept all critical electronic equipment like High Power Amplifiers (HPA) and cryogenic

cooled Low Noise Amplifiers (LNA) can be placed into the equipment room at ground level and thus eases operation and maintenance. The optional Ka-band equipment will be located in the upper azimuth portion and will be rotated in azimuth.

The X-band uplink and downlink chains will be redundant. Tracking measurements will be made by the IFMS. The antenna position will be controlled by a Front-end Controller, based on current systems. Telemetry will be processed and stored by telemetry processors (TMP), which provide the source of the data to be transmitted to the NCTRS at ESOC. Telecommand messages from the MCC will be processed by the telecommand encoder (TCE Mk IV) for uplink. A Portable Simulator System will be configured to represent Herschel to support ground station testing, and the interfaces to the control centre for telemetry and telecommand.

3.1.3.1.2 Availability of the Network

The architecture of the ESA stations is such that all the essential parts of the stations with the exception of the antenna are redundant. In addition, all the stations subsystems are thoroughly tested and validated in their operational environment before being declared operational, and prove to be very reliable.

In addition to the redundancy, each station is equipped with a set of the most important spares, leaving to the station personnel the possibility in case of equipment failure to make a simple unit exchange while continuing to provide the required functionality with the redundant chain.

It has to be noted as well that each station is equipped with its own power supply based on diesel generators and static converters for provision of short break and no break power. During critical phases of supported missions, the stations are functioning on internal power, the public power supply being available as backup.

The availability of the ESA Network, based on these architecture principles, has been excellent for previous missions.

3.1.3.2 Communications

3.1.3.2.1 Operational Communications Network

The current ESA Operational Communications Network consists of X25 nodes (ISS) deployed at each ESA station and at ESOC, interconnected via leased or public ISDN communications lines. By 2007, X.25 will have been replaced by TCP/IP. Figure 8 shows an indicative overall topology of the communications.

As shown in Figure 8, it is proposed to provide redundant communication lines to each of the stations: one permanent (leased line), and a redundant (ISDN type) procured at L-3 months.

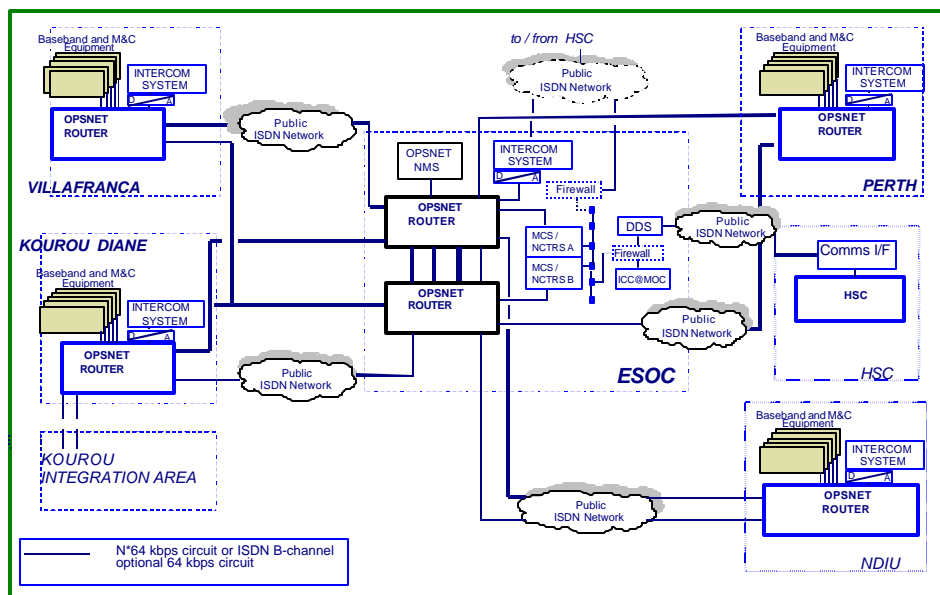

Figure 8: Overview of the communication network.

3.1.3.2.2 LEOP Control Centre to SVT site Communications

In order to support the System Validation Tests, using the spacecraft, a redundant interface for telemetry/telecommand and voice, using a Network Data Interface Unit (NDIU) and ISDN lines will be set-up between the Mission Control Centre and the Integration facilities. In order to ensure the availability of the equipment the NDIU will be shipped with spare parts, and for the period of interface establishment, an ESOC technician will be present. For at least one of the tests a full NDIU will be used, the rest may use a NDIU_{lite}.

3.1.3.2.3 Mission Control Centre to HSC Communications

The interface to the HSC for the exchange of data (telemetry, auxiliary data, mission planning data, databases, software maintenance data) will be based on the File Transfer System (FTS) for file based transfers and the generic Data Distribution System (DDS) for non-file based transfers.

3.1.3.2.4 LEOP Control Centre to CSG Communications

In order to monitor the status of the satellite after its shipment to Kourou, while it is either in the Integration area or on the launcher during the last days before the lift-off, an interface (telemetry and voice) will be provided between the LEOP Control Centre at ESOC and the CSG Interface in Kourou via the CSG's private fibre optic Network (ASTRE).

These links to CSG shall be established from Launch minus 30 days.

3.1.3.3 Mission Control Centre

The Herschel Operations will be conducted from ESOC, Darmstadt.

ESOC is equipped with the requisite facilities and staffing to ensure 24 hrs spacecraft monitoring and control capability (within the constraints of ground station coverage), including a no-break power system, independent of the local supplier (HEAG).

The major elements of the Herschel control system are the following:

- Facilities and internal communications
- Interface to the Network
- Mission Control System
 - Mission Archive
 - Performance Evaluation
 - External Interfaces
 - On-board Software Maintenance (Management)
- Flight Dynamics Services
- The simulator
- Mission Planning
- Data distribution and file transfer services
- On-board software development and maintenance

3.1.3.3.1 Operations Control Centre Facilities

The operations will be conducted from the Main Control Room (LEOP) and the DCA, Flight Dynamics Services will be provided from the Flight Dynamics Room (LEOP), Communication and Network operations from the Ground Configuration Control Room. The Project Support Room (LEOP) will be made available for the Herschel support team. Other facilities for infrastructure services will be made available as required. Figure 9 depicts the ESOC computer and local area network configuration for Herschel support.

The operations control facilities are free of single points of failures. The availability of the infrastructure is based on redundancies. Details can be found in the description of the individual elements.

3.1.3.3.2 Interface to the Network

The interface between the ground station network and the Mission Control System will be provided by the generic NCTRS.

3.1.3.3.3 Mission Control System (MCS)

The Herschel Mission Control System will be based on the SCOS-2000 control system. In addition to the standard telemetry and telecommand facilities, it will include on-board software maintenance facilities for the management of software maintenance operations (configuration control, patch generation from images, dump and comparison operations). The facilities for platform software development and modification shall be installed at ESOC and accepted. For the first year, software maintenance will be the responsibility of the Prime contractor.

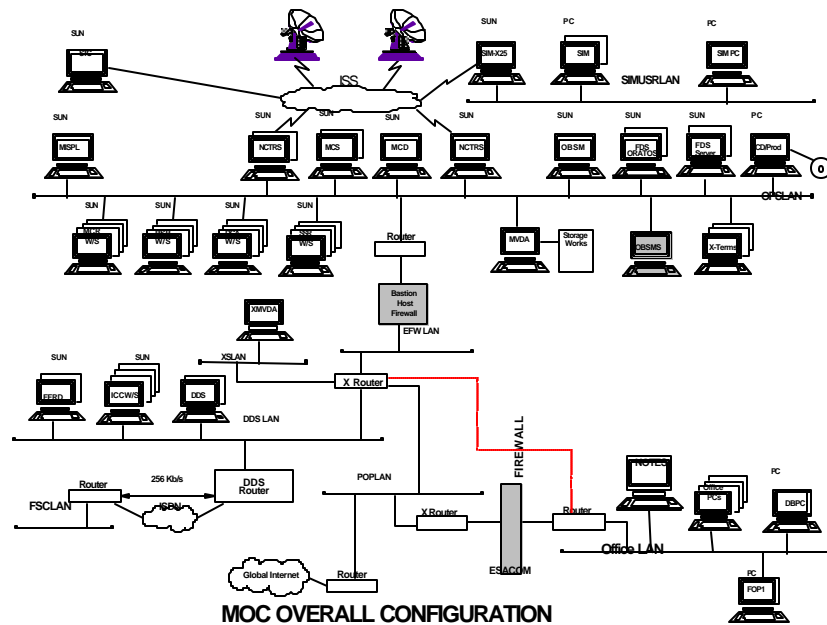

Figure 9: Representative MOC Computer and Network configuration for Herschel

Whilst many of the Herschel requirements can be covered by the configuration of the generic SCOS-2000 facilities, there will be some specific developments which cover e.g.:

- System management and configuration components
- Monitoring components, covering both spacecraft and non-spacecraft data monitoring
- Commanding components
- Spacecraft systems modelling
- Data storage components
- External interfaces to Flight Dynamics, Mission Planning, the DDS, the ICC@MOC and the ground segment
- On-board memory management
- The mission archive

3.1.3.3.4 Database

The requirements on the Prime contractor prescribe a common database for ground and flight operations. It is assumed that a Rosetta-like implementation will be pursued, with a master and mirror sites, and the database having domains, which are specific to the user site. The MCS runtime database will be derived from an export from the database in a SCOS-2000 compatible format.

3.1.3.3.5 Procedure Preparation Tool

The WINFOPS/ MOIS software suite will be used for procedure production. WinFOPS is a Flight Operations Plan(FOP) procedure text editor It has an MS Excel based HMI front end and stores all the procedure information in a normalised relational MS Jet database; one per FOP procedure. The WinFOPS development has been running in parallel with the Mission Office Information System (MOIS) study. The MOIS study provides a COTS based framework for FOP Procedure development, configuration control and validation. In this respect, WinFOPS can be considered as another COTS tool to be integrated into this MOIS framework.

WINFOPS/ MOIS will access the database to retrieve data and to store resulting sequences.

3.1.3.3.6 Performance Evaluation

The Performance evaluation will be based on the generic PE system, which provides an access mechanism to archived data, so that the retrieved information can be conveniently used by a data processing software suite such as PV-wave or Excel.

3.1.3.3.7 On-board Software Management

The generic SCOS-2000 OBSM system will be configured for the Platform and Payload processors, assuming that they support incremental patching as a means of memory maintenance. Small incremental patches are assumed as the normal case in keeping with the limited uplink bandwidth and the restricted contact times. The OBSM utilities provide for

- Import of images from a software development environment
- configuration management of the on-board systems
- maintenance of a reference on-board image
- patch generation by image comparison
- command sequence generation for loading the patch
- command sequence generation for dump operations
- comparison of dumps with images.

3.1.3.3.8 Mission Control System Hardware Configuration

The Herschel SCOS-2000 system will consist of two server machines, and up to 18 user workstations. The servers will run the OPSNET interface, common processing and the filing. The user workstation will run the user interface and local processing. The user workstations will be located in the MCR, the DCR and the project support room. In addition, two workstations will be provided to the ESOC operation staff for the database update and the FOP production.

In case of hardware failure of one server, the client workstations are still able to receive and process without interruption (hot stand-by back-up system) the telemetry data from the other server. The failing equipment is replaced and the data restored with no delay by the in-house support staff. During the actual LEOP, Computers and Local Area Network support is provided on site 24 hours. An exhaustive set of spare parts is stored in-house, so that failing items can be replaced immediately.

In case of hardware failure of a client workstation, the tasks can be taken over by another client workstation. The failed equipment will be replaced analogous to a server failure case.

The availability of the Herschel can be assumed equivalent to the availability of other mission configurations, for which statistical data based on experience are provided:

- No computer / LAN down time has been registered so far in any of the LEOP missions operated by ESOC.
- The availability of the operational systems currently in use at ESOC is close to 100% (without scheduled downtimes).

3.1.3.4 *Flight Dynamics Service*

The Flight Dynamics system is based on the ORATOS software infrastructure. The functionality required for Herschel will have to be developed, but advantage will be taken of the ISO, XMM and Integral experience as much as possible.

3.1.3.4.1 *Hardware Description*

The current infrastructure is described as it is considered indicative of any infrastructure in place in 2007.

The flight dynamics operational software resides on a computer infrastructure dedicated to Flight Dynamics, based on SUN workstations presently running under Solaris. This infrastructure is organised as follows:

- Development platform composed of one file server interconnected through a common LAN to which individual clients are attached, for software development and maintenance work;
- Integration platform made of one file server and three clients, connected to the same LAN mentioned before, used to integrate and test operational software before its release to the operational platforms (see below);
- LEOP platform, made of two redundant file servers equipped with mirrored disc systems (ensuring high availability), several clients (including so-called number-crunchers and X25 connection to ESA ground stations used for STDN) connected to the servers through two redundant network branches: the full platform is connected to the completely isolated ESOC operational LAN and is available in the flight dynamics room and its Annexes. The usage of this platform will be shared with Planck (and possibly other missions) during mission preparations (system tests and simulations) and LEOP operations.
- Routine operations platform, made of one file server, several clients (including so-called number crunchers and X25 connection to ESA ground stations used for STDN), connected to operational LAN: this platform will be used for routine operations of other ESA missions and also as backup to the LEOP platform.

This computer hardware infrastructure has been used for all projects supported by the Flight Dynamics division at ESOC since 1994. It is therefore fully operational and permanently maintained, and its configuration is carefully kept up to date. This infrastructure offers a full operational availability without any single point of failure thanks to internal redundancy. The LEOP platform can be re-configured within a few minutes to its mirrored disc system or its backup servers, which is sufficient for nominal LEOP operations (and of course SVT). During critical operations, the software will run simultaneously on the LEOP and the routine operations platforms connected respectively to the prime and backup SCOS-2000 telemetry servers (so-called hot backup configuration). In this configuration, one can carry on operations

without interruption should anyone of the hardware component fail. This set-up provides, if needed, 100% availability and is absolutely free of any potential single point of failure.

3.1.3.4.2 *Software Description*

Flight Dynamics support (FDS) for Herschel based on the ISO experience will provide for:

- Orbit determination for the transfer to L2 and for the Lissajous orbit at L2
- Orbit control for the transfer to L2 and for the Lissajous orbit at L2
- Mission Planning Support:
 - Delivery of planning tools to the HSC (slew predictors etc.)
 - Preparation of mission planning products: (PSF, etc.)
- Attitude determination and Control
 - AOCS monitoring and Calibration
 - AOCS command parameter generation
- Product Quality checking

3.1.3.4.3 *FDS Services*

Flight dynamics will provide support:

- to the ground segment integration and test
- to the LEOP and transfer operations
- to the Commissioning and PV Phases
- to the routine operations.

3.1.3.5 *Spacecraft and Instrument Simulator*

The Herschel simulator will be used intensively during the Mission Preparation Phase in support of the following activities:

- To test and validate the spacecraft control and monitoring system.
- To test and validate the flight control procedures for nominal and contingency cases.
- To train of flight control staff.
- To perform rehearsals of mission scenarios during the simulation programme.
- To test updates to on-board software (OBSW).
- To perform end-to-end test dry runs .

The behaviour of the spacecraft and instrument subsystems and dynamics relevant for the operations are required to be simulated realistically. The interface between the spacecraft control and monitoring system and the simulator will be at the level of the OCC communications node, i.e. the simulator will model the behaviour of the various telemetry and telecommand ground station equipment used during the Herschel operations.

3.1.3.5.1 *Hardware configuration*

The simulator will be based on an Intel platform running Windows 2000[®] with the interface to the network via a Sun running the OSI Stack

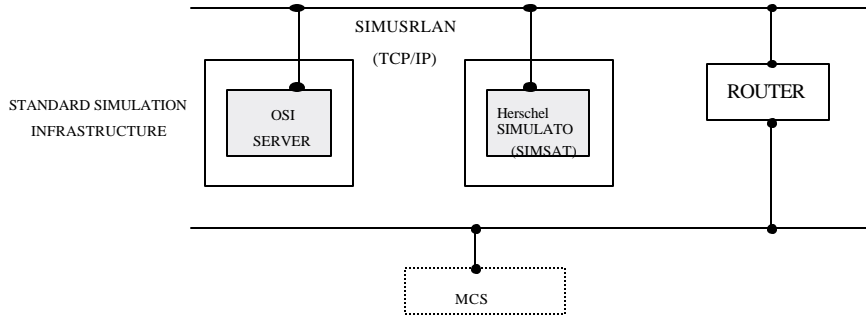

Figure 10: Standard Simulation Infrastructure

3.1.3.5.2 Software Description

The simulator will be based on the SIMSAT-NT infrastructure, and assumes the reuse of existing emulations of on-board processors, and existing simulations of other on-board equipment.

The payload is assumed to be simulated at the level of the engineering reaction and responses to telecommands as seen in the instrument housekeeping telemetry. Science telemetry will be generated only to provide a representative stream into the MOC.

The diagram shows the software structure for the simulator, showing the relationship between infrastructure, operating system and software developed for Herschel.

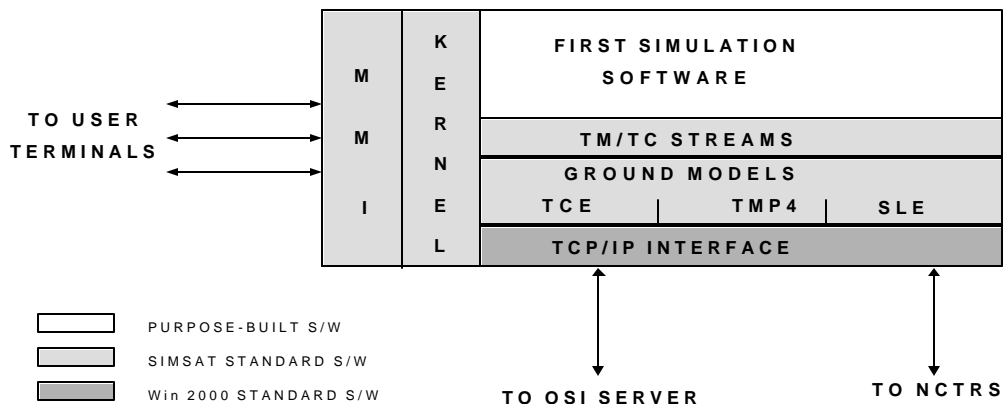

Figure 11: Simulator software structure

3.1.3.6 Mission Planning

Mission planning is a multistage process, partly performed by the MOC and partly by the science ground segment. Figure 12 shows a preliminary planning flow, resulting in a plan for the space and ground station operations.

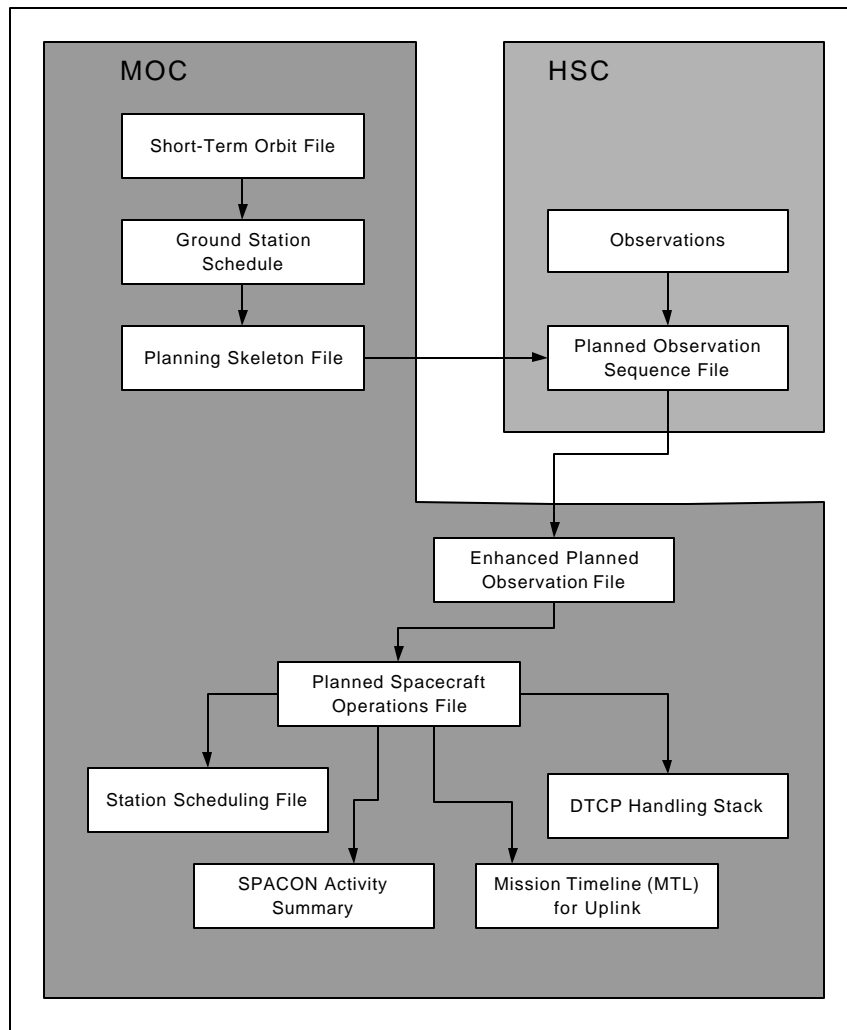

Figure 12: Mission planning flow

The short-term orbit file is a prediction of the orbit for at least 4 weeks into the future. The MOC scheduling office uses this to produce the ground station schedule (GSS) every week, for 4 weeks into the future. Flight Dynamics incorporates the GSS information into the planning skeleton file (PSF), which contains windows for other spacecraft activities such as orbit maintenance manoeuvres. This is performed at least 3 weeks before operations. The PSF is used by the HSC in their generation of the planned observation sequence file (POS), which contains the data provided by the PSF interspersed with instrument commanding and attitude requests.

At least two weeks before operations Flight Dynamics receives the POS from the HSC and expands attitude-related event designators (EDs) as necessary and populates the attitude/ orbit related windows from the PSF where appropriate. The resulting enhanced planned observation sequence file (EPOS) is passed to the Flight Control Team (FCT) which translates both instrument and attitude EDs into commands or sequences and adds any further commanding required to satisfy engineering requirements at that time. EPOS processing results in the planned spacecraft operations file (PSOF) from which the daily mission timelines (MTLs) are produced to be subsequently loaded on-board the satellite.

The schedule for the ground station will be generated at the same time. This will define the operations to execute:

- Station equipment configuration for Herschel.
- The pre-pass tests.
- The acquisition.
- The ranging operations.
- The acquisition of high data rate.
- The post pass operations.

The products and intermediate data files of the Mission Planning process are exchanged between the MOC and HSC via the FTS. If the planning cannot be accomplished as expected, the HSC will be informed and a new POS solicited.

3.1.3.7 Data Distribution

The Data Distribution Service (DDS) and the File Transfer System (FTS) will support the interface to the HCS for the transfer of data from the MOC to the HSC and vice versa. All data required for the operations is assumed to be transferred via the HSC, regardless of the originator. The data to be transferred is typically as follows:

HSC to MOC

Data	Form
Observation Plan	Files

MOC to HSC

Data	Form
Skeleton Plan	Files
Final Plan	Files
Commanding Timeline Summary	File
Telemetry	File
Time correlation	File
Telecommand History	File
Orbit and attitude reconstituted	File
Reporting	Document
FOP (for information)	Document
Database	File
SSO DB	File

Operations Status Info	Document
------------------------	----------

ICC to MOC (via HSC)

Data	Form
Database (including command sequences)	File
Instrument user manual including procedures	Document
On-board software images	Files
Software memory maps/ definition	Files/ document
Instrument Apertures and Pointing Misalignment	File

MOC to ICC (via HSC)

Data	Form
Database	File
FOP (for information)	Document

The DDS will be used for the transfer of data which is being transferred as a constant stream (telemetry for example) while the FTS will be used for the periodic transfer of data (for example, the skeleton plan, final plan) or the transfer of irregular data (for example, on-board software images).

All data recorded will be dumped (i.e. the data which is received in real-time will be duplicated at the MOC).

The telemetry at the MOC will be archived in the DDS as files of data (probably for 7-10 days), from which it is accessible to the HSC (and to the ICCs). The telemetry will be organised by type, application ID and time:

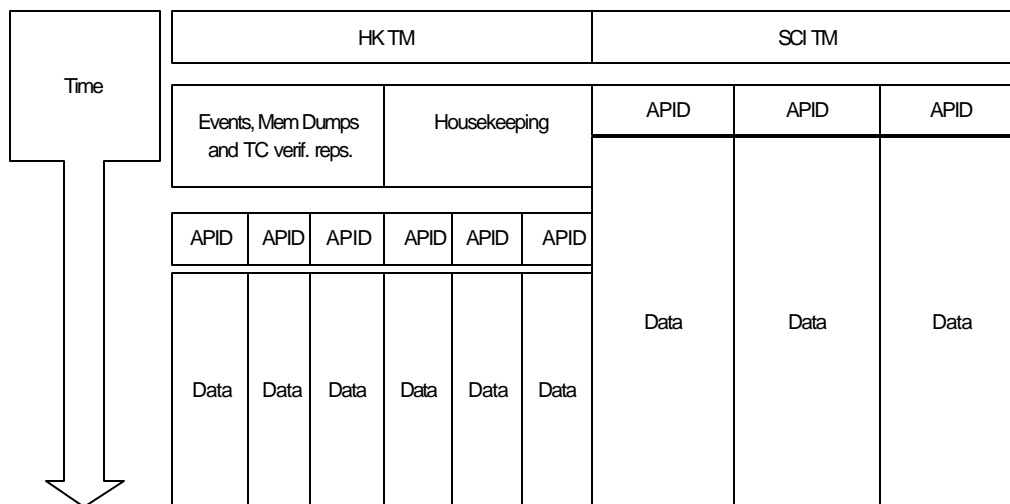

Figure 13: The DDS structure

3.1.3.7.1 *Extraction of data from the DDS*

Access to the data from the DDS can be via a catalogue, which defines (for telemetry), on an APID basis, the data which is available on the DDS. The system can be designed so that data is placed immediately on the DDS and the catalogue defines the last data arrived and also the time for which the data which are considered to be complete, either because they are, or because the “consolidation time” has expired. (The consolidation time is the time after which no more data can be expected to be received pertaining to the time period for which the data is being merged into a time ordered stream.) It may be practical to declare the consolidation time earlier for certain types of data (e.g. events and telecommand reports) so that they appear in the archive as consolidated very quickly.

The advantage of such a system is that real-time data can be made available to a user almost as soon as it arrives, without waiting for consolidation.

The DDS is a near real-time processing system, which provides data access on a demand driven basis, i.e. the PIs or HSC are responsible for respective data requests. The MOC will not “push” data to the HSC. It is assumed that the user (ICC or HSC) will request data from the data archive (DDS) by APID and time period as required. The data / message transmission will be via transfer only.

Telemetry data is provided as raw data and therefore the users will need the MOC database to interpret the non-science data.

DDS interfaces will be governed by the Data Disposition Interface Document (DDID). This document will be issued and agreed with all users (HSC and PIs). It will be put under configuration control as ESOC's formal delivery commitment. The DDID will describe the formatting of delivered data down to the necessary level of detail to enable users to retrieve science data and any required housekeeping or auxiliary data.

3.1.3.8 *On-board software development and maintenance*

The Prime contractor will deliver a software development environment and software validation system to ESOC for the maintenance and configuration management of the on-board software in the various subsystems. The output from the system will be new software images, which are passed to the SCOS-2000 based on-board software management (OBSM) system for the generation of new patches to be transferred to the spacecraft

3.1.4 Real time analysis (RTA)

The RTA will support the extraction, conversion and display of housekeeping parameters from a stream of instrument housekeeping telemetry as well as the monitoring of these parameters against their expected value or status. In addition, it will support command verification, on-board memory checking and the monitoring of events.

RTA features two modes: the real-time mode and the playback mode. The real-time mode is not used in the routine operations phase (except for contingency situations); it is described in section 3.2.4 for ILT and section 3.6.4 for commissioning.

In its playback mode, the RTA component will retrieve telemetry data from the HCSS (see section 3.1.10). In this mode the relevant interfaces shall accommodate a data flow corresponding to 10 times the on-board data rate.

RTA will be based on the SCOS-2000 system during all phases of the mission.

3.1.5 Instrument On-board Software Maintenance (OBSM)

The instrument OBSM is used to generate new instrument on-board software images. It consists of a dedicated system to generate a new version of the on-board software (OBSW), to compile it, to generate checking parameters (checksum etc.) and to test its functional performance.

The OBSM will generate an image in the form as required by the MCS for uplinking. This image will be transferred to the HCSS for the project scientist's approval.

3.1.6 MIB Editor

The MIB editor system will be used in the routine operations phase to update the satellite database, see also section 3.1.3.3.4 The satellite database contains information about the configuration of the instrument and satellite monitoring software (SCOS-2000), the uplink (telecommand) and downlink (telemetry) data of each instrument and the spacecraft.

The database contains the following information:

- Configuration of the SCOS-2000 system, e.g. views, calibration tables, derived parameters definition, mimic displays etc.
- Definition of downlink telemetry, e.g. structure and definition of instrument housekeeping telemetry, as well as information to detect out-of-limit values in the telemetry.
- Definition of uplink, e.g. telecommand mnemonics, telecommand parameters, telecommand packets, telecommand sequences...

The database will have the same format for all three instruments; they will be generated by the database editor supplied with SCOS-2000. They will be generated as plain ASCII files and will be imported in the different systems using them: the MOC system, RTA, and the HCSS.

The source of the database is the same for all systems in the HGS (i.e. the HCSS, the MOC system, RTA and EGSE-ILT, which are all SCOS-2000 based). The source maintenance is under responsibility of the MOC.

3.1.7 Instrument simulator

This section has been incorporated into section 3.1.3.5 as the development of the instrument simulator is now part of the spacecraft simulator development under the responsibility of ESOC (and not a 3^d party delivery from the ICCs).

3.1.8 HSC–MOC interfaces

The interface between the HSC and the MOC will be file based. It will be supported on the MOC side by the DDS [and the FTS subsystems](#) (see section 0) which will serve files to the HSC upon request or which will store files exported from the HSC. The HSC will implement a number of functions to interface to the DDS [and FTS](#). These functions are further described in this section

3.1.8.1 *The telemetry interface towards MOC*

This side of the interface covers the importation of consolidated telemetry from the MOC to the HSC. It is operational throughout the following mission phases: Commissioning, PV, and routine operations. The consolidated telemetry is expected to include the derived parameters generated by the MOC. They will be included in the form of telemetry packets with their own APIDs.

This interface has the following functions:

1. Request files of consolidated telemetry from the DDS, the request will include. The following parameters: time range (with respect to the on-board time at which the telemetry have been generated), APID. The APID will differ according to instruments but also according to the category of telemetry, i.e. housekeeping or science.
2. Import requested files containing consolidated telemetry from the DDS.
3. Interface with the telemetry archiving function.

With respect to requesting files from the DDS:

- The request for telemetry will be triggered by the availability of consolidated telemetry. This assumes that the availability of consolidated telemetry per APID can be requested from the DDS (see section 0).
- The consolidated telemetry interface function is expected to request telemetry files from the DDS in an automatic fashion, the frequency of request may depend on the mission phase in order to meet the different performance requirements for telemetry availability at ICCs.
- The telemetry interface function has the responsibility of not missing telemetry and is expected to be smart enough to avoid importing telemetry packets twice.

With respect to importing the requested files an ftp-based protocol is expected to be used. As telemetry transfer may involve large files (e.g. up to 1 GB), it is expected that the protocol will be able to recover from communication failure without having to restart the transfer from the start.

With respect to the interface, the telemetry archiving function is expected to be the same for NRT telemetry and consolidated telemetry (see section 3.1.8.2) and therefore only have one implementation independently of whether it archives consolidated or NRT telemetry. The telemetry archiving function should receive NRT telemetry as a stream of packets. Consequently, the consolidated telemetry interface should translate files of telemetry data as received from the DDS into a stream of telemetry packets.

3.1.8.2 *The telemetry interface towards the HCSS*

This side of the interface covers the archiving of the telemetry into the HCSS ODBMS where they can then be retrieved by the different HCSS applications. In addition to the routine operations phase, the archiving

function is expected to be operational throughout the following mission phases: ILT, IST, Commissioning, and PV.

Although in the routine operations phase in the HSC this function will only ingest consolidated telemetry, the telemetry archiving function is indeed expected to be the same for consolidated telemetry, NRT telemetry (see section 3.6.8) and largely the same for telemetry from the EGSE-ILT or the CCS (see section discussion below).

In all cases, the telemetry archiving function is expected to receive telemetry data as a stream of telemetry source packets formatted according to ESA packet standards [RD-3][RD-4].

The telemetry archiving function will archive telemetry as telemetry source packets; i.e. as generated by the instruments or the spacecraft. This source telemetry packets archive will allow telemetry playback to RTA and, when needed, for reprocessing of science data. In addition to this basic archiving, the telemetry ingestion will generate and archive data frames. The concept of data frame is explained below.

Due to the small size of the telemetry packets and despite the possible on-board compression, the science data can not always be put into one single telemetry packet. The three instruments on-board Herschel follow three different (levels of) on-board processing of their science data. The concept is presented in Figure 14 below which shows the combined science data processing scheme for all three instruments.

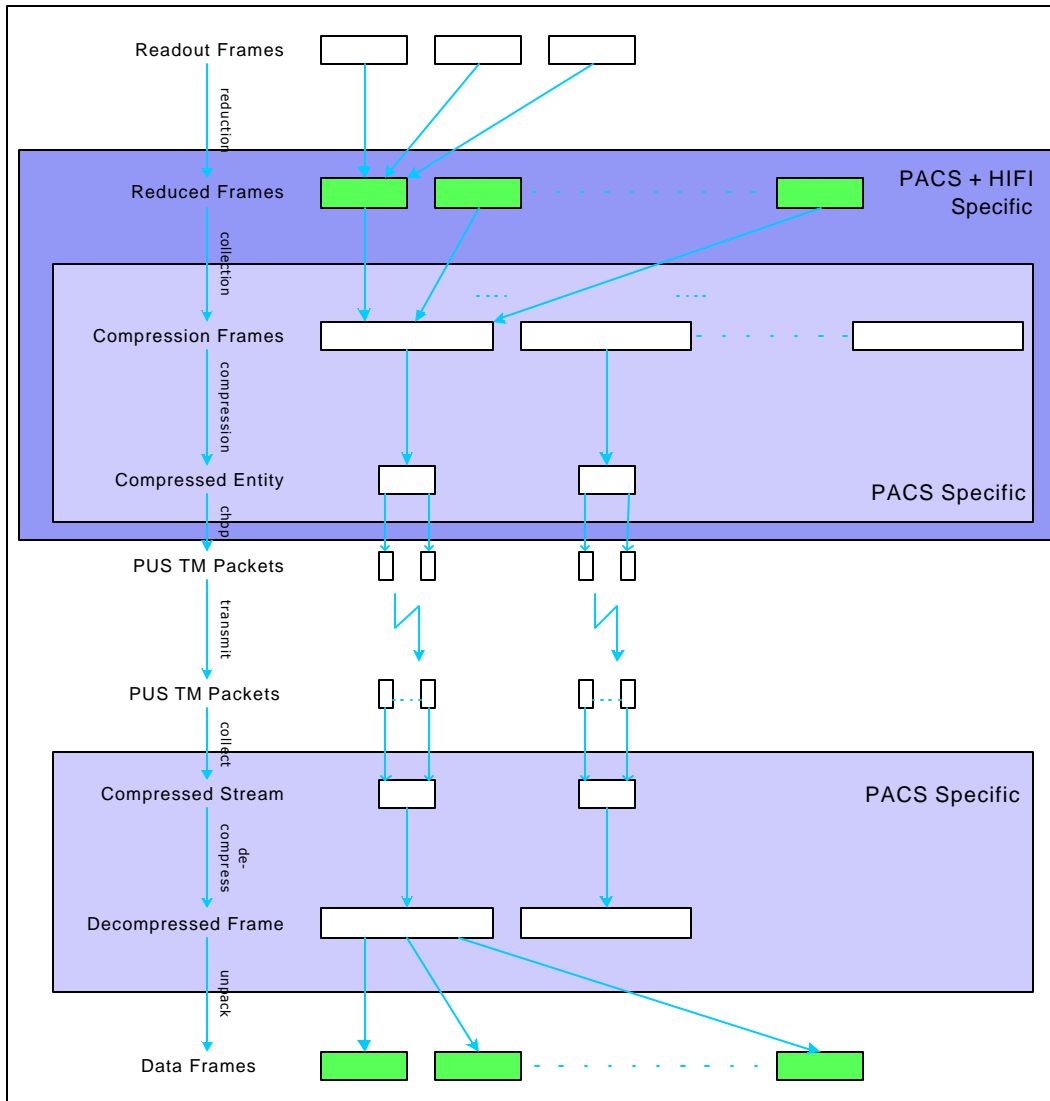

Figure 14: The concept of telemetry data processing.

The readout frames at the top are the individual detector readouts. For PACS and HIFI these detector readouts will be reduced by the OBSW. PACS then further collects these reduced frames in an internal buffer and compresses the buffer into a 'compressed entity'. The compressed entities for PACS and the reduced frames for HIFI are then chopped into PUS telemetry packets that are sent to the ground. SPIRE does not need this on-board reduction/ compression mechanism and puts each readout frame into a corresponding PUS telemetry packet. On the ground PACS needs to collect and decompress the PUS telemetry packets again to end up with workable self-standing entities that are called *dataframes*. Data frames in principle represent the on-board reduced frames. Both are coloured in green in the above figure to

point out that these individual frames are labelled with the current observation identifier (`ObsId`) and building block identifier (`BbId`). Since for SPIRE and HIFI the PUS telemetry packets and data frames are essentially the same, these instruments also have their PUS telemetry packets labelled with `ObsId` and `BbId`. This is not true for PACS where the PUS telemetry packets are not labelled accordingly.

The ingestion of telemetry shall be such that any telemetry data (either PUS telemetry packets or data frames) can be related by users to their originating observation and observation building block when relevant, i.e. the observation building block execution during which they have been generated. This will include telemetry related to parallel and serendipity observations. To this effect, each instrument telemetry packet or data frame will have been tagged with the current `ObsId` and `BbId` by its instrument OBSW. The HCSS will provide functionality to relate or associate non-instrument telemetry to the observation and observation building block by their on-board generation time tags. The on-board time tag will be in spacecraft time while the reference time for the HGS will be UTC. A time correlation will therefore have to take place in the HCSS to relate spacecraft time with UTC.

The observation and observation building block context and Id will be generated as part of the schedule and transmitted to the instruments as part of dedicated telecommand (see also MPS in section 3.1.2.3).

The telemetry archiving function will also have to deal with telemetry that is not related to an observation. The following cases can be identified:

- Instrument housekeeping telemetry for the instruments not involved in the observation (i.e. housekeeping telemetry from the non-prime instrument). The archiving of these telemetry shall be such that they can be easily related to the observation in order to study possible interference between instruments. The archiving of these will be done based on generation time.
- Instrument telemetry that results from commanding by the MOC outside a mission timeline (manual commanding) or within a mission timeline but outside the context of an observation. Manual commanding by MOC will be done at the level of instrument command sequences that can map in the CUS concept to observation building blocks (see section 3.1.2.1). These instrument command sequences will be associated with a default `ObsId`. All instrument telemetry packets generated as a result of these instrument command sequences will be tagged with this default `ObsId` by the instrument OBSW to ease the identification and processing of these 'special' telemetry packets within the HCSS.
- Spacecraft telemetry that results from manual commanding by the MOC will be archived on generation time basis.

The telemetry archiving function shall not make any assumptions on the sequence of the stream of telemetry it will receive, in fact it should be possible to store each telemetry packet independently from its predecessor and or successor. The order of telemetry packets is important though in order to collect and de-compress telemetry packets into data frames.

In the routine operations phase, the telemetry archiving function will most likely receive telemetry packets ordered by APID and then, for each APID, according to the telemetry generation time. For NRT telemetry (see section 3.6.8) the telemetry archiving will receive telemetry sorted by virtual channel (housekeeping and science telemetry with no further distinction made per APID). In addition, for NRT telemetry, the time

sequence of telemetry packets cannot be guaranteed as telemetry packets lost between the ground station and MOC can later be retrieved by MOC and transmitted via the DDS.

The telemetry archiving function will have to meet the following real-time constraints. It will have to be able to ingest telemetry data at a higher rate than the on-board telemetry data generation rate (i.e. 100kbps) and it shall be such that the delay between the start of the ingestion and the retrieval of this packet at a HCSS local node does not exceed one minute.

3.1.8.3 *The MOC software and data interface towards HSC*

This side of the interface covers the importation of the MOC software and data (at the exclusion of telemetry) from the MOC to the HSC. In addition to the routine operations phase, this function is operational throughout the commissioning and the PV mission phases.

The interface covers the following data:

- Spacecraft orbit predictor software and data
- Spacecraft Attitude constraint software and data
- Spacecraft slew time and path predictor software and data
- Planning skeleton data
- Observations schedule status information
- Mission timeline summary
- Telecommand history
- Out of limit (OOL) data
- Spacecraft orbit data (reconstituted)
- Spacecraft attitude history
- Time correlation
- Instrument memory image
- Spacecraft and instruments databases (MIB)
- Instrument aperture pointing misalignment
- SSO database

All of these data will be imported from MOC to the HSC as files [using the FTS](#).

At this point, one should distinguish between the data periodically produced (i.e. for each operational day) and data produced on a one-off basis. The former are:

- Planning skeleton data
- Observations schedule status information
- Mission timeline summary
- Telecommand history
- OOL data
- Spacecraft orbit data (reconstituted)
- Spacecraft attitude history
- Time correlation

For data produced on a regular basis, the import from MOC will be automatically triggered based on a polling mechanism initiated by HSC. For non-regular data the MOC will notify the HSC when it becomes available for retrieval.

3.1.8.4 MOC software and data interface towards the HCSS

This set of interfaces covers the ingestion of MOC software and data (see section 3.1.8.3) into the HCSS where they can then be retrieved by the different HCSS applications. With respect to archiving, one should distinguish between ancillary data, software and other data.

3.1.8.4.1 Ancillary data

The ancillary data are the following data:

- Mission timeline summary
- Telecommand history
- OOL data
- Spacecraft orbit data (reconstituted)
- Spacecraft attitude history
- Time correlation

In addition to the routine operations phase, this function is expected to be operational throughout the following mission phases: Commissioning, PV and ILT/ IST for the telecommand history and the OOL data.

For telecommand history and OOL data the archiving function is expected to be largely the same for the data generated by the MCS and the ones generated by the RTA in ILT or the CCS in IST. As already mentioned this is partially guaranteed by the fact that all three systems, the RTA, the CCS and the MCS (subset of the MOC system) will be SCOS-2000 based.

The ingestion of the telecommand history data should allow the association in the HCSS of an executed observation with status information on the execution of the telecommands related to this observation. This implies that the HCSS will be able to easily establish the correspondence between the telecommand generated by MOC and the commanding requests issued by the HCSS.

The archiving of ancillary data in ILT and IST are further discussed respectively in sections 3.2 and 3.3.

The same comments as for telemetry (see section 3.1.8.2) applies for those ancillary data which cannot be related to an observation.

3.1.8.4.2 MOC software and data

The MOC software and data are the following:

- Spacecraft orbit predictor software and data
- Spacecraft attitude constraint software and data
- Spacecraft slew time and path predictor software and data

The MOC will only make available the algorithms used for producing the data described above. The Common Software Development Team (CSDT) will do the actual implementation of these algorithms in the HCSS. The algorithms and data items are relevant only to the in-orbit phase.

3.1.8.4.3 *Others*

Other MOC data that will be archived by the HCSS are the following:

- Planning skeleton data
- Observations schedule status information
- Instrument memory image
- Spacecraft and instruments databases (MIB)
- SSO database
- Instrument aperture pointing misalignment

Except for the MIB, these data are relevant to the in-orbit phase only. A subset of a new MIB as imported from the MOC will need to be ingested into the HCSS to be used as input to the CUS, the SPG and the IA/QLA. The subset of the MIB that will require ingestion into the HCSS will be described in a specific ICD.

3.1.8.5 *The schedule interface towards MOC*

This side of the interface will cover the exportation to the [MOC](#) of the schedule produced by the HSC (see MPS in 3.1.2.3). In addition to the routine operations phase, this function will be operational throughout the following mission phases: Commissioning, PV.

The schedule will be exported [via](#) the [FTS](#) from the HSC as a file.

3.1.8.6 *The schedule interface towards the HCSS*

This side of the interface will cover the extraction of the schedule data from the HCSS as generated by the MPS and the formatting of these data into a file to be exported to MOC. There will be one schedule file for each operational day. In addition to the routine operations phase, this interface will be operational throughout the following mission phases: Commissioning, and PV.

The schedule file is expected to be constituted of the planning skeleton data as imported from MOC and the telecommand mnemonics generated by the MPS implementing the observations schedule.

3.1.8.7 *The ICC data interface towards MOC*

This function covers the exportation to the MOC of the schedule produced by the HSC and ICC data needed to operate the MOC. In addition to the routine operations phase, this function is operational throughout the following mission phases: Commissioning, PV.

This will include the following data:

- Instrument on-board software (OSW) updates

- SSO database updates
- Instruments database updates
- Instruments procedures and command sequence updates
- Instrument aperture pointing misalignment updates

All of these data will be exported to MOC from the HSC as files [using the FTS](#).

The instrument OBSW updates will consist in the complete instrument memory images. It will then be up to the MOC OBSM (see section 3.1.3.3.7) to generate the appropriate memory patches.

Instrument procedures—i.e. (mostly) manual instrument procedures to be invoked by MOC personnel in contingency situations—will be delivered by the instrument teams as part of the instrument user manual. MOC will generate the operator instrument procedures using the same tools as used for the satellite procedures i.e. MOIS/ WINFOPS.

3.1.8.8 *The ICC data interface towards the HCSS*

This side of the interface covers the extraction of data (see section 3.1.8.3) from the HCSS ODBMS and the formatting of these data into files (when relevant) for export to MOC. In addition to the routine operations phase, this interface is operational throughout the following mission phases: Commissioning, PV and also to ILT and IST for the instrument database and instrument OBSW.

3.1.9 HSC—ICC interfaces

These interfaces will be object based. Objects created in any of the HSC or ICC (e.g. as a result of the archiving of telemetry in HSC or new instrument calibration parameters in ICC) will be (when relevant) accessible in a transparent manner to any of the other centre. As mentioned in section 2.2.4, the HSC-ICC interfaces are intrinsic to the HCSS and rely on the ODBMS remote access or replication mechanism.

Interfaces between ICCs (e.g. between PACS-ICC and HIFI-ICC) will a priori flow through the HSC-ICC dedicated lines and the HSC-HCSS node. However, it cannot be excluded that for data that are of no interest to the HSC, data flows directly between the ICCs through ICC managed communication lines. This is to be supported by the HCSS.

3.1.10 HCSS—RTA interfaces

This interface is principally a telemetry interface from the HCSS to the RTA for playing back housekeeping telemetry. For this purpose, the HCSS and RTA will interface through the router, which will act as a front-end to RTA. SCOS-2000 documentation defines the minimum functionality to be supported by the router (e.g. detection of missing telemetry packets, telemetry packets bufferisation). The telemetry packets ingested into the HCSS will not include the SCOS-2000 headers. The router will add SCOS-2000 headers to telemetry packets for RTA purposes. No SCOS-2000 functionality will be lost having the HCSS between the telemetry interface and RTA, in particular it should still be possible to playback telemetry and automatically resynchronise with real-time monitoring.

The HCSS-RTA interface will also allow the storage of RTA logs into the HCSS.

3.1.11 HCSS—OBSM interface

The interface will implement the storage and retrieval of OBSW images generated by the OBSM to and from the HCSS. The HCSS will keep the OBSW images under configuration management. The OBSW images will be exported from the HCSS to the MOC, see therefore section 3.1.8.7.

3.1.12 HCSS—MIB editor interface

The interface will implement the storage and retrieval of the MIB files generated by the MIB editor to and from the HCSS. The HCSS will keep the MIB under configuration management. The MIB files will be exported from the HCSS to the MOC, see therefore section 3.1.8.7.

At ingestion the MIB files will be interpreted and the interpreted data will be ingested such that other HCSS components (e.g. CUS, IA/ QLA) have access to the instrument telemetry and telecommand definitions and calibration curves.

3.2 *Instrument level test (ILT) phase*

3.2.1 Introduction

The ILT phase is the mission phase in which the functional, environmental and scientific testing of the instruments are performed. This includes characterising the instruments and establishing calibration parameters and procedures for the instruments.

3.2.1.1 *Smooth transition*

The objective is to operate the instruments using observations as the basic containers for both commanding as well as data archiving and reduction (see section 2.2.3).

To be able to (efficiently) use the observation as a basic entity in the ILT phase to encapsulate instrument test commanding and the resulting data, all ILT phase operations and procedures have to mimic the routine operations phase environment. This is done by emulating a number of HGS functions that do not exist as such during ILT and by using, as much as feasible, standard HGS interfaces between the different functions. When needed (slightly) adapted versions of these interfaces will be adopted during ILT.

The functions have to be simulated in such a way that most, if not all, operational systems that are used for ILT can be exploited to their fullest during the in-orbit phase without significant changes.

3.2.1.2 *Specific HGS functions that have to be emulated*

The major differences that exist between the ILT phase and the routine operations phase are:

- There is no Herschel satellite. During this phase the instruments are being tested in the laboratory
- There is no MOC component of the HGS and therefore no MOC system components. The MOC exists to control the Herschel spacecraft during the in-orbit phase.
- Operations are performed in real-time.

To allow the instrument engineers and calibrators to interact with their instrument certain key functionality/behaviour provided in the routine operations phase by the MOC and the spacecraft must be emulated. The MOC functions that have to be emulated are:

- Telecommand generation and uplink
- Telemetry downlink and monitoring
- Telemetry distribution

The satellite functions that have to be emulated are:

- On-board schedule
- On-board autonomy
- Satellite bus protocol
- Time synchronization
- Monitoring and maintaining the instrument environment.

Note: Strictly speaking the satellite functions are outside the scope (the HGS) of this document. However during the ILT and IST phases the satellite can be considered as on the ground and therefore to make up a component of the HGS. In the ILT phase the satellite is not available and its key functions must therefore be emulated.

The HGS component that emulates the key MOC (and satellite) functions during the ILT phase is the electrical ground segment equipment (EGSE-ILT).

An extra component of the HGS which is present in the ILT phase but not in the routine phase is the additional test equipment. Some of this equipment will maintain and monitor the environmental conditions of the instrument under test while some of it is used to give stimuli to the instrument. As for the instrument, the aim is to be able to operate the test equipment using 'observations' as the basic containers (see above).

3.2.1.3 Commonality

ILTs are performed at each instrument consortium site. Each instrument team will use the same set-up for their instrument testing.

3.2.1.4 The ILT set-up

Figure 15 shows the set-up for the ILT phase. Within the EGSE-ILT system a number of MOC and satellite functions are emulated.

First, there is an interface unit (the EGSE telemetry/ telecommand router), which acts as the NCTRS and the satellite CDMS in operation. On the HGS side this interface functions as a telemetry/ telecommand relay station that can also relay telecommand/ telemetry data to/ from ILT test equipment. The commanding component implements the functions related to the generation of telecommand packets and the RTA system implements all the housekeeping telemetry monitoring functions. Finally, Test Control (TOPE) encompasses all activities needed to define and execute test procedures, doing manual interaction/ intervention and, together with the RTA, emulate on-board autonomy. The test control needs to be implemented specifically for ILT and will not (likely) be reused during the routine operations phase.

The remaining components or systems are expected to be the same or a subset of what will exist for the routine operations phase functions: MIB editor, CUS, ODBMS, database browsers, CC, OBSM, RTA and IA/ QLA.

Whenever possible the interface as defined for the routine operations phase will be honoured.

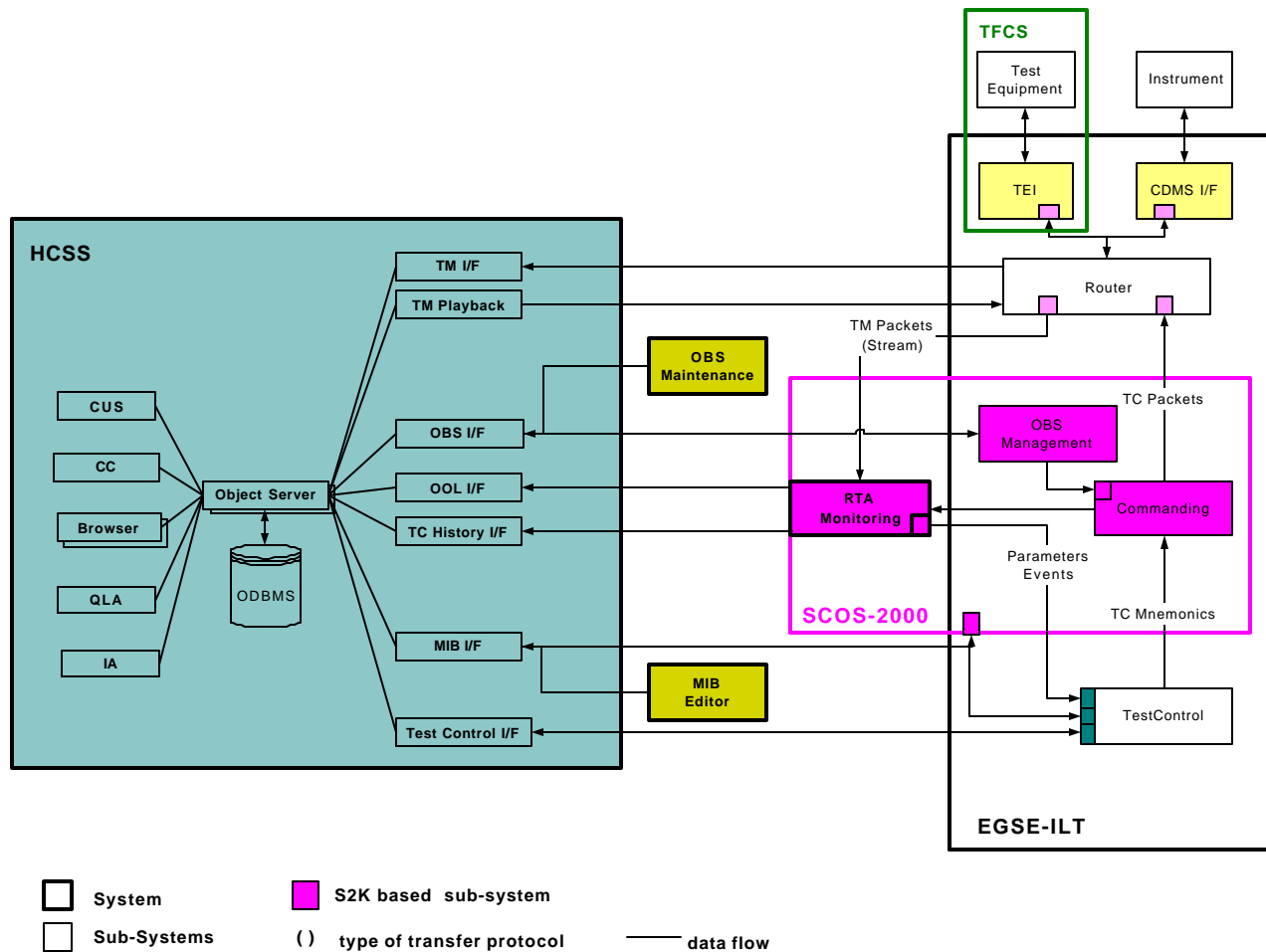

Figure 15: The HGS in ILT

3.2.2 HCSS components for ILT

3.2.2.1 CUS

The CUS component will be used as in the routine operations phase to define observation modes and building blocks. The building blocks, and thus the modes, will be based on the individual commands through their corresponding telecommand mnemonics as defined in the MIB. As in routine operations, observations will be created from building blocks and individual instrument commands (see section 3.1.2.1).

Specifically for ILT, a number of building blocks that are used for controlling test equipment will be generated from the CUS. From the CUS point of view, these extensions will behave exactly as normal instrument or spacecraft commands. As an example like standard building blocks these special building

blocks will also have a building block identifier (BbId) such that in the telemetry resulting from a test also the data generated by test equipment in a given test has a unique ObsId-BbId combination.

3.2.2.2 PHS

The PHS component is not used as such in the ILT. In ILT, the generation of observations will be driven by the Test Control through the Test Control interface (see section 3.2.7.1) instead of the PHS and the MPS in the routine operations phase. The generation of observations will however be based on the same HCSS core services (see section 3.1.2.9) as in the routine operations phase.

3.2.2.3 MPS

Same comment as for the PHS above.

3.2.2.4 QCP

There is no need for Quality Control Products as such during ILT and this component will therefore not be available during this phase.

3.2.2.5 CC

The Configuration Control System will be used in the same fashion as in the routine operations phase, see section 3.1.2.5.

It is expected that in the ILT phase a number of software, data and documentation items will be under full configuration control, while others are still 'under development'. Unfortunately, it is likely that for some items the time constraints inherent to a testing period may require a 'liberal' interpretation of the configuration management rules. In these cases, the CC will be used as a means of tracking changes more than as a means of checking changes.

3.2.2.6 Database browsers

Same as in the routine operations phase, see section 3.1.2.6.

3.2.2.7 IA/QLA

IA/QLA will be used largely the same way as by instrument experts in the routine operations phase, see sections 3.1.2.7 and 3.1.2.8.

The actually available IA/QLA analysis functionalities will be less extensive than that which will be available in the routine operations phase (as they are still under development and more concentrated on functionalities needed to analyse the ILT results).

3.2.2.8 HCSS-ODBMS

In all cases where items are stored in or retrieved from the HCSS, this will be done according to the standards defined for the routine operations phase. This includes the setting of access rights and version

control. In practice, all active ILT personnel will get very liberal access rights for all data entered into the system.

In the ILT phase an instrument group will have one master HCSS node, which is the node directly associated with the test environment. The full HCSS replication mechanisms are not expected to be in place in this phase, therefore when other HCSS nodes require data and/ or (newly developed) software from that node some form of ‘manual replication’ will have to be used. This could range from—manually initiated—export and FTP type ingest operations to—again possibly manually initiated—low-level ODBMS based replication.

The ILT phase data that is stored in the local database will become part of the distributed HCSS after ILT and IST. This could be realised by having this physical database fully integrated with the single logical and distributed database that makes up the HCSS during the routine operations phase. Note that forward compatibility will be maintained also for ILT phase data e.g. when the schema evolves ILT phase data might need to be re-ingested in order to be able to access and process this data at any time during the mission.

In the ILT phase the HCSS will offer the same core services as in the routine operations phase at least for the ones related to observations (see section 3.1.2.9). In particular, instantiation of an observation, generation of telecommand mnemonic sequences, computation of ‘observing time’, retrieval of telemetry related to an observation or a building block will be implemented.

3.2.3 EGSE-ILT components

3.2.3.1 Test Control

As part of Test Control, it will be possible to define test procedures, including flow control logic as well as references to ‘observing modes and parameters’ previously defined through the HCSS CUS system. The generated test procedures will be stored in the HCSS.

At run time, Test Control will resolve the reference to the observing modes by requesting to the HCSS, through the Test Control interface (see section 3.2.7.1), the translation of an observing mode plus parameters into a sequence of relative time tagged telecommand mnemonics. The telecommand mnemonics will then be released by Test Control at the appropriate time and sent through the commanding component of the EGSE-ILT to the interface unit (see section 3.2.3.3) to be forwarded to the instrument or test equipment. These activities under Test Control functions emulate the execution of the on-board schedule. If required a test procedure can be altered or aborted from Test Control.

When Test Control receives events or telemetry parameter values from RTA, it will react by executing predefined procedures (automatically or under user control). This loop emulates the on-board autonomy functions.

Autonomy procedures are expected to be defined in the same way as test procedures. However they will not be allowed to reference observing modes and therefore cannot execute command sequences generated by the HCSS.

From Test Control also manual commands can be sent to the instrument and test equipment, thereby emulating the CDMS as master controller as well as direct ground to satellite commanding.

3.2.3.2 *Commanding*

As during the routine operations phase (see MCS, section 3.1.3.3.3), the commanding component is fully based on SCOS-2000.

The commanding component receives individual telecommand mnemonics from Test Control, converts them to telecommand packets, verifies these and when valid sends them to the interface unit. The commanding component is expected to release the telecommand immediately as Test Control manages the timing for command release.

3.2.3.3 *The Telecommand/ Telemetry Interface Unit*

The telecommand/ telemetry interface unit encompasses the telecommand/ telemetry EGSE router, the test environment interface (TEI) and the CDMS interface. It distributes telecommand packets to the instrument through the CDMS interface and to the different test equipment used in ILT through their TEI. From the instrument and the TEIs, the telemetry/ telecommand EGSE router receives telemetry packets that it forwards to the monitoring component and to the HCSS.

It is recommended that, like the instrument, the TEIs receive observation and building block identifiers (ObsId, BbId) in their command stream so that TEIs can label their telemetry with these identifiers. When the TEI and instrument data are then ingested into the HCSS it will be straightforward to make associations for telemetry from different sources generated during a given building block.

With respect to the exchange of telecommand and telemetry packets with the instrument, the CDMS interface simulates the satellite bus protocol. The telemetry/ telecommand EGSE router therefore simulates the NCTRS/ MOC for the delivery of the telemetry to the HCSS in REAL TIME.

3.2.3.4 *On-board Software Management*

This component will have the same behaviour and functionalities as in the routine operations phase, see section 3.1.3.3.7.

3.2.4 RTA (monitoring)

As in the routine operations phase, RTA is SCOS-2000 based and can be seen as an extension of the SCOS-2000 monitoring function.

The monitoring component verifies the telemetry packets. The telecommand verification packets received are compared to the telecommand sent to construct the telecommand History. The telecommand history is subsequently transferred to the HCSS for archiving, see section 3.2.7.4

The telemetry is monitored for parameters and/ or events that are of interest to Test Control to drive the execution of test procedures. These telemetry parameters or events (e.g. OOL events) are sent to Test Control in real-time. This is used in particular to implement the autonomy function.

In the 'real-time' mode, a telemetry stream will feed RTA directly from the interface unit. In its 'playback' mode during ILT, the RTA component will function exactly as it will during the routine operations phase (see section 3.1.3).

Products generated by RTA real-time (e.g. OOL events) will be ingested in the HCSS, see section 3.2.8.

3.2.5 Instrument On-board Software Maintenance (OBSM)

The instrument OBSM facility during the ILT phase will have the same functionalities as in the routine operations phase (see section 3.1.3) with the following comments: as in routine operations, the OBSW updates are generated by the OBSM facility and archived in the HCSS mainly for configuration control purpose. The OBSW image is retrieved from the HCSS and sent to the OBSM component through the OBS interface. In addition to this interface, it will be possible in ILT to directly load a new OBSW image by-passing the OBSM and the translation of a memory patch into telecommands. In fact, it is expected that the latter interface be used only in ILT to validate the OBSM in the context of the Herschel instruments.

Any configuration control processes associated with OBSW updates during the routine operations phase will be used in the same manner during the ILT phase.

3.2.6 MIB editor

Same as in the routine operations phase with the following comments: in the ILT phase, the scope of the MIB will be different from its scope in the routine operations phase. In ILT the MIB will include the definition of the telecommands and telemetry data related to the test equipment and will not include spacecraft related data. Telecommands and telemetry for the test equipment are expected to be defined in the same way as instrument telecommands and telemetry.

Although, different in scope, the MIB format is expected to be compatible with the routine operations phase, i.e. with the SCOS-2000 MIB interface.

3.2.7 HCSS—EGSE-ILT interfaces

3.2.7.1 Test Control interface

The HCSS Test Control interface component will interface with the EGSE-ILT Test Control to:

- provide Test Control with the available observing modes for reference in test procedures at the time of editing a test procedure,
- provide Test Control with command mnemonic sequences following a Test Control request during test procedure execution, and to

- store or retrieve test procedure definitions and execution logs to or from the HCSS. Further to storing test procedure execution logs, the test procedure logs may be used in the HCSS to group test observations, in the same way as proposals in the routine operations phase.

The generation of the command mnemonics, driven by the Test Control interface will be based on the same HCSS core observation services as used by PHS or MPS in the routine operations phase, namely:

- the creation of an observation request from an observing mode with parameters,
- the instantiation of an observation and generation of unique `ObsId` and `BbIds`,
- the generation of the sequence of the telecommand mnemonics corresponding to the observation request.

The generation of a test schedule upon request from Test Control is expected to be performed in real-time as part of the execution of the test procedure.

3.2.7.2 *OBS interface*

Towards the EGSE-ILT, it is expected that the OBS interface will interface directly with the SCOS-2000 OBSM component.

The memory image transferred over to the EGSE-ILT is expected to have the same format as the image transfer to MOC in the routine operations phase, as the same SCOS-2000 based OBSM component is expected to be used in all phases.

The part of this interface toward the OBSM is covered in section 3.2.9.

3.2.7.3 *Telemetry interface*

As in the routine operations phase, the telemetry interface will have to store telemetry in standard telemetry objects and associate that telemetry with the appropriate 'observations' and building blocks in the database. This association is done in the HCSS by correlating the telemetry `ObsId` and `BbId` tags with the actual observation and building block ID's. ILT telemetry packets not related to observations or without `ObsId` and `BbId` tags (e.g. telemetry originating from the TEI) will be ingested in the HCSS based on time key.

The telemetry interface will have to be able to cope with the instrument data rate (currently this implies about 300 kbit/s as in the PACS burst mode) plus the TEI data rate. Telemetry packets generated by the instrument will have to be processed and ingested into the HCSS in real-time.

On its receiver side, the telemetry interface will need to have a dedicated adapter to be able to receive a telemetry stream as coming from the EGSE-ILT interface unit function.

On the transmission side, it will need to interface with the HCSS. This part is (essentially) the same as in the 'consolidated telemetry interface' used in the routine operations phase.

The possibility exists, especially in the test phases, that independent HCSS nodes will be ingesting telemetry data simultaneously. An example is IST tests on the qualification model running in parallel with an ILT test on the flight model. If the resulting telemetry packet objects originate from the same instrument (albeit

different models) they can bear the same APIDs, time tags, etc, making it difficult or impossible to use these criteria to identify them uniquely.

A solution to this problem could be to mark telemetry with an id uniquely identifying the HCSS node which have acquired this telemetry. The id could also be used to identify instrument model/ configuration, EGSE model/ configuration.

3.2.7.4 Telecommand history interface

The telecommand history interface component will be used as in the routine operations phase. It will archive a telecommand history object and associate it with the appropriate observation and/ or telemetry object(s) according to the practice to be used in routine operations (see section 3.1.8.4.1)

The telecommand history interface will get the telecommand history information from the RTA in a format compatible with the telecommand history format in the routine operations phase.

3.2.7.5 MIB interface

Towards the EGSE-ILT and RTA, this interface will support the retrieval from these two systems of a given version of the MIB in the format delivered by the MIB editor.

The part of this interface toward the MIB editor is covered under 3.2.10.

3.2.8 HCSS—RTA interface

Same as in the routine operations phase (see section 3.1.10) with the following comment: in ILT, OOL data will be generated by the RTA and the HCSS—RTA interface will have to support the importation and ingestion of OOL data into the HCSS. In ILT, OOL data are generated in the same format as in the routine operations phase and the implementation of its ingestion into the HCSS therefore is the same as in routine operation.

3.2.9 HCSS—OBS maintenance interface

Same as in the routine operations phase, see section 3.1.11.

3.2.10 HCSS—MIB editor interface

Same as in the routine operations phase (see section 3.1.12), for the storage and Configuration Control of the MIB by the HCSS.

In ILT, this interface shall also support the ingestion of a relevant subset of the MIB for telecommand and telemetry data definition needed as input to the CUS and the IA/ QLA. The ingestion process is the same as in the routine operations phase as the same MIB format will be used, see sections 3.1.8.4.3 and 3.2.6

3.3 *Integrated system test (IST) phase*

3.3.1 Introduction

The IST phase is the mission phase in which the correct implementation of all spacecraft interfaces, including those with the instruments, are verified using the integrated spacecraft. This section addresses the IST phase from the perspective of the HGS systems that will be required to support the tests which actively involve the instruments. These tests will be conducted by industry using the Central Checkout System (CCS) with the instrument engineers and calibrators monitoring the activities via the Instrument-EGSE.

The instrument modes of operation have been defined and validated during the ILT phase. The IST phase will be used to demonstrate that the instruments still operate as expected (from the ILT phase) when integrated with the spacecraft. To this end it is necessary to test only a representative sample of the observing modes defined for each instrument.

3.3.1.1 *Smooth transition*

As described for the ILT mission phase (section 3.2) the objective is to operate the instruments in all mission phases using observations as the basic containers for both commanding as well as data archiving and reduction. In order to be able to do this a number of the in-orbit phase HGS functions have to be emulated.

3.3.1.2 *Specific HGS functions that have to be emulated*

The commissioning phase is the most appropriate in-orbit phase to emulate during the IST mission phase. From a HGS systems perspective the commissioning phase has the same systems as in the routine phase but the operations are performed in real time and facilities are provided for the instrument engineers and calibrators to monitor their instruments performance in real-time (the ICC@MOC capability) and to provide feedback on the commanding of the instruments. This is precisely what is required during the IST mission phase.

Comparing the IST phase with the commissioning phase the major differences that exist are:

- There is no MOC component of the HGS and therefore no MOC system components. The MOC exists to control the Herschel spacecraft during the in-orbit phase.
- There is no ICC@MOC component.

To allow interaction with, and monitoring of, the spacecraft and instruments certain key functionality/behaviour provided in the commissioning phase by the MOC and the ICC@MOC must be emulated. The MOC functions that need to be emulated for IST are the following:

- Mission timeline generation
- Telecommand uplink
- Time correlation
- Telemetry downlink and monitoring
- Telemetry distribution

The ICC@MOC functions that need to be emulated are the following:

- Real time instrument telemetry monitoring

The HGS components that emulate the key missing MOC and ICC@MOC functions during the IST phase are the Central Checkout System (CCS) and the Instrument-EGSE.

3.3.1.3 Commonality

A single HCSS and a single Instrument-EGSE is used during the IST irrespective of the instrument under test.

3.3.1.4 The IST set-up

Figure 16 shows the set-up for the IST phase. Within the CCS and the Instrument-EGSE system a number of MOC and [ICC@MOC](#) functions are emulated. The telemetry/ telecommand front end equipment (telemetry/ telecommand FEE) and the Instrument-EGSE router represent all the MOC activities that are necessary to uplink time tagged commands to the satellite and to receive and distribute real-time telemetry.

The SCOE represents the test equipment and environment needed to interact with the instruments during tests while the CCS Test Control function encompasses all activities related to defining, running and monitoring test procedures. It should be noted that, instruments wise, only bona-fide test procedures generated during the ILT phase will be implemented in these tests.

The Instrument-EGSE is seen to encompass the RTA function which provides the real time housekeeping telemetry monitoring capability provided by the [ICC@MOC](#). It is noted that there is a second RTA in Figure 16. This is used by the CCS operator to monitor spacecraft and instrument functions (analogous to the MOC set-up in commissioning and routine phases).

In the commissioning phase the mission timeline generation is, in the early stages, a manual procedure with the needed telecommands being loaded onto the manual stack, the necessary non-default parameter values being specified and then being uplinked. In IST the same approach of delivering a “pseudo schedule” which defines a single observation (see section 2.1.3) is taken. The schedule is loaded, the needed values are supplied and the schedule is executed.

Limited capability is provided for real-time parameter update during the IST mission phase in the same way that a comprehensive capability is provided in the ILT mission phase (see section 3.2). This capability is handled by the Instrument-EGSE test control. It receives requests for real-time parameters from the CCS test control and forwards these requests to the HCSS in such a way that the HCSS/ Instrument-EGSE test control interface is identical to that used in the ILT mission phase. Similarly the response of the HCSS is received by the Instrument-EGSE test control and forwarded to the CCS test control in a format acceptable to the CCS.

The remaining functions are similar to HGS functions: IA/ QLA for science data monitoring and analysis, and CUS for generating ‘test observations’.

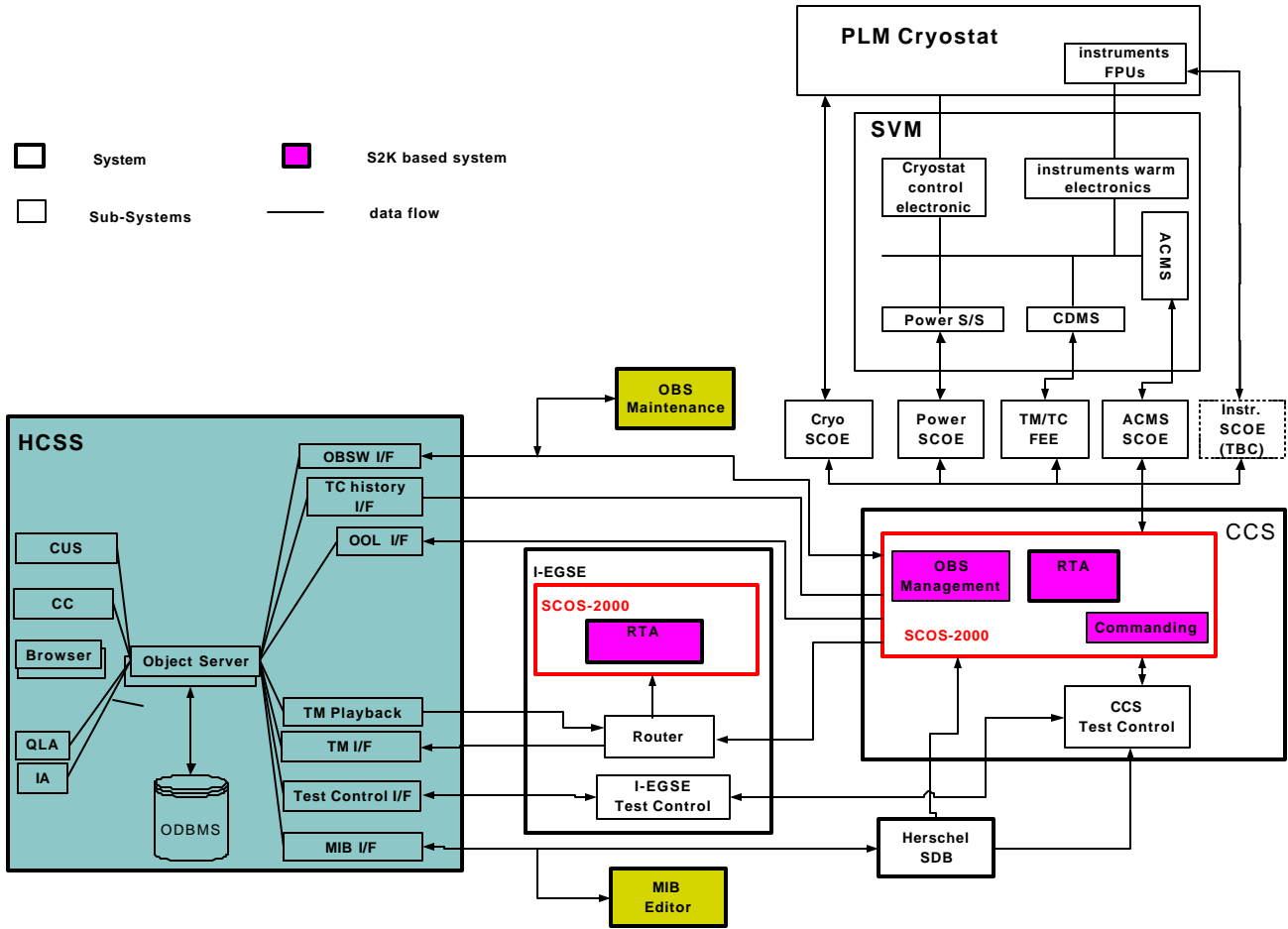

Figure 16: The HGS in IST

3.3.2 HCSS components for IST

3.3.2.1 CUS

Same as for ILT, see section 3.2.2.1

3.3.2.2 *PHS*

Same as for ILT, see section 3.2.2.2

3.3.2.3 *MPS*

Same as for ILT, see section 3.2.2.3

3.3.2.4 *QCP*

N/A

3.3.2.5 *CC*

Same as in the routine operations phase, see section 3.1.2.5

3.3.2.6 *Database browsers*

Same as in the routine operations phase, see section 3.1.2.6

3.3.2.7 *IA/QLA*

Same as in ILT, see section 3.2.2.7

3.3.2.8 *HCSS-ODBMS*

Same as in ILT, see section 3.2.2.8

3.3.3 CCS components

3.3.3.1 *Test Control (CCS)*

The Test Control function in IST mimics the MOC system functions for manual commanding, mission timeline generation, time correlation and telemetry monitoring (together with RTA).

The generation of the mission timeline will be based on sequences of relative time tagged command mnemonics generated by the HCSS, see Test Control interface (section 3.3.8.1). The Test Control will send the mission timeline to the telemetry/ telecommand FEE to be forwarded to the spacecraft and when relevant to the instruments via the satellite CDMS.

The Test Control will also allow direct communication with the satellite or instrument via the FEE.

3.3.3.2 *Telemetry/ Telecommand FEE*

This component essentially simulates the MOC function of sending time tagged commands to the satellite and receiving telemetry from it.

The CCS should allow the upload of OBSW images at a faster (TBD) rate than possible during in-orbit operations, with the instrument DPU/ ICU bus providing the only constraint.

3.3.3.3 FEE

The FEE covers all the test equipment needed to interact with the instrument during the tests.

3.3.3.4 On-board Software Management

Same functionalities as in the routine operations phase, see section 3.1.3.3.7. However it may not be SCOS-2000 based.

3.3.4 Instrument-EGSE components

3.3.4.1 Test Control (EGSE)

The Instrument-EGSE test control receives requests for observation instantiation from the CCS test control. The Instrument-EGSE test control communicates this request to the HCSS using the same interface as was used during the ILT mission phase (see section 3.2.7.1). Upon receiving the instantiated observation from the HCSS the Instrument-EGSE test control forwards the required information to the CCS test control.

3.3.4.2 Telemetry router

The Instrument-EGSE router receives telemetry packets from the CCS and distributes them to the HCSS and to RTA. This is the same router used in the ILT mission phase (see section 3.2.3.3).

3.3.5 RTA

As in routine operations and ILT phase, RTA is SCOS-2000 based.

In the 'real-time' mode a telemetry stream will feed RTA directly from the CCS telemetry server via the telemetry router. In its 'playback' mode during IST, the RTA component will function exactly like it will during routine operations (see section 3.1.3).

Text deleted.

Contrary to ILT, in IST, RTA will

- not be used to generate the telecommand history and the out of limits data, as this will be done by the CCS itself, and
- not support the feed-back loop driving test procedure execution. Consequently, there will be no automatic real-time feed back from RTA to the CCS for driving the test execution. Staff monitoring the real time telemetry at the RTA will communicate with the CCS staff through a voice loop.

3.3.6 On-board software maintenance (OBSM)

Same as in the routine operations phase, see section 3.1.5

3.3.7 MIB editor

Same as in ILT phase, see section 3.2.6.

3.3.8 HCSS—Instrument-EGSE Interfaces

3.3.8.1 *Test Control interface*

Same as in ILT phase, see section 3.2.6.

3.3.8.2 *Telemetry interface*

Same as in ILT, see section 3.2.7.3

3.3.9 Instrument-EGSE—CCS interfaces

3.3.9.1 *Test Control interface*

This interface will conform to the CCS external interface definition.

3.3.10 HCSS—CCS interfaces

3.3.10.1 *OBS interface*

Towards the CCS, this interface will support the retrieval of a given version of an instrument OBS image in the format delivered by the OBS Maintenance. No direct interface is expected from the HCSS to the CCS. OBS image updates will be retrieved from the HCSS via this interface and manually handed over to the staff operating the CCS via Project (TBC).

The OBS image updates handed over to the CCS are expected to have the same format as the OBS updates transferred to MOC in the routine operations phase.

The part of this interface toward the OBS Maintenance is covered under section 3.3.12.

3.3.10.2 *CCS data interface*

This set of interfaces cover the importation of the CCS data (at the exclusion of telemetry) to the HCSS. This includes the following data:

- the telecommand history data
- the out of limits data
- the instrument memory image (memory dump) (TBC)
- the spacecraft and instrument databases i.e. the MIB (TBC)

The data is delivered to the HCSS in the same format as during routine operation, making the ingestion implementation of these data items in the HCSS the same as in routine operation.

3.3.10.3 *MIB interface*

Towards the CCS, this interface will support the retrieval of a given version of an instrument MIB in the format delivered by the MIB editor. No direct interface is expected from the HCSS to the CCS. MIB updates will be retrieved from the HCSS via this interface and manually handed over to the staff operating the CCS via Project (TBC).

The MIB updates handed over to the CCS is expected to have the same format as the MIB updates transfer to MOC in the routine operations phase.

The part of this interface toward the MIB editor is covered in section 3.3.13.

3.3.11 HCSS—RTA interface

Same as in the routine operations phase, see section 3.1.10.

3.3.12 HCSS—OBS Maintenance interface

Same as in the routine operations phase, see section 3.1.11.

3.3.13 HCSS—MIB editor interface

Same as in the routine operations phase, see section 3.1.12, for the storage and configuration control of the MIB updates by the HCSS.

3.4 *Ground segment tests*

Same as during the commissioning phase, see section 3.6.

3.5 *Launch and early operations phase (LEOP)*

This phase will involve mainly the MOC system. The MOC system is described in section 3.1.3 including for specific characteristics related to LEOP especially in section 3.1.3.2.

The involvement of the HCSS in this phase is mainly limited to a listening in mode.

3.6 *Commissioning phase*

3.6.1 Introduction

The activities of the instrument-commissioning phase will focus on switch-on activities and functional checkout of the instrument subsystems and their modes. The tests will be very similar to the tests carried out during integrated system tests (IST) plus observations to confirm the instrument/ satellite system characteristics (e.g. instrument aperture pointing).

The Herschel Ground Segment will be composed of the same basic systems as for routine operations (i.e. the Mission Operations Control System (MOC System), the Herschel Common Science System (HCSS), RTA and the OBSM), and extended with an additional centre, the ICC located at the MOC (ICC@MOC).

This section describes in detail the ICC@MOC centre and the specific interfaces that are set-up for this phase. All differences in components and interfaces with respect to routine operations will be explained in specific sections. The HGS system design for commissioning phase is also valid during calibration and performance verification phase and in a reduced set-up during contingencies in routine operations.

3.6.1.1 *The ground segment set-up during commissioning phase*

The Herschel Ground Segment set-up as during commissioning phase is presented in Figure 17. The most obvious difference with routine operations is the additional ICC@MOC centres.

The ICCs will set-up a specific environment to perform real-time activities at the MOC during this phase. The environment will consist of a RTA system, the OBSM system and the QLA subsystem of interactive analysis (IA/ QLA). All software systems interface with a local HCSS node that provides telemetry data from the consolidated archive. The local HCSS node also receives unconsolidated telemetry from the telemetry interface in (near) real-time for distribution to local IA/ QLA applications. The RTA system receives (near) real-time telemetry directly from the MOC system.

During the commissioning phase and for instrument emergencies, the MOC shall make available to an ICC@MOC its instrument telemetry not later than 1 minute after the telemetry packet has been received by MOC.

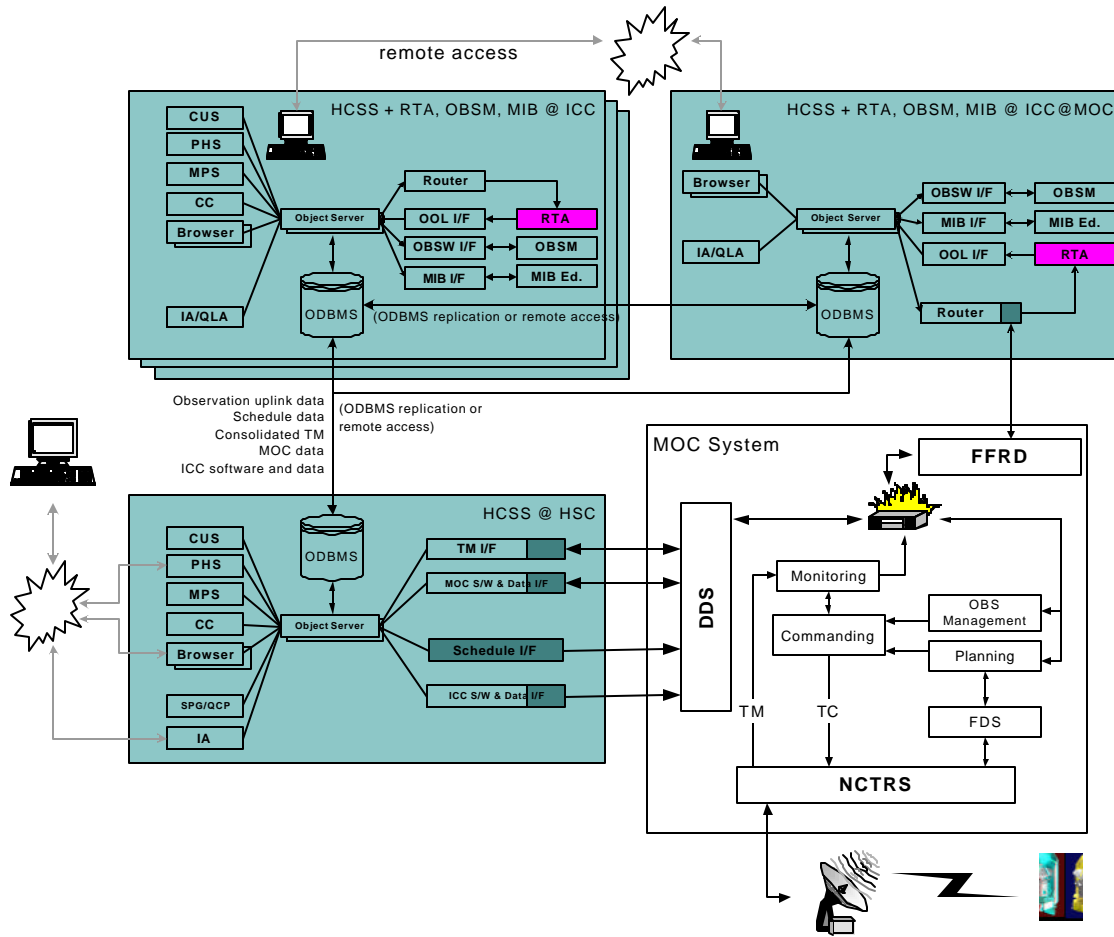

Figure 17: The HGS in commissioning phase

3.6.2 The HCSS components for commissioning phase

3.6.2.1 CUS

Same as in the routine operations phase, see section 3.1.2.1.

3.6.2.2 PHS

Same as in routine operations (see section 3.1.2.2) with the precision that in commissioning, the PHS will be used mainly to generate the test and engineering observations, which will be grouped into a set of 'generic' commissioning proposals.

3.6.2.3 MPS

Same as in the routine operations phase, see section 3.1.2.3.

3.6.2.4 QCP

N/A

3.6.2.5 CC

Same as in the routine operations phase, see section 3.1.3.5.

3.6.2.6 Database browsers

Same as in the routine operations phase, see section 3.1.3.6.

3.6.2.7 IA/QLA

Same as in the routine operations phase, see section 3.1.2.7.

3.6.2.8 HCSS-ODBMS

Same as in the routine operations phase, see section 3.1.2.9.

3.6.3 MOC System components

The MOC system is essentially the same in commissioning as in the routine operations phase, except for the facilities that are used to deliver the telemetry in NRT to the ICC@MOC, see below.

3.6.3.1 Herschel Frame Decommutator

During the Herschel Commissioning and Calibration/ Performance Verification Phases most activities will be conducted by ICC staff at the MOC. This requires a working ICC software environment at the ICC@MOC. A communication link from the Herschel MCS to the ICC workstations is used to provide the telemetry (housekeeping and Science) in near real-time.

The Herschel MCS is located on ESOC's Operational LAN (OPSLAN). For this LAN there exists the security requirement that no external node may be able to connect to any internal node. Therefore special measures are applicable. Core of these measures is the security bridge between the OPSLAN and the Data Distribution LAN (DDSLAN). To achieve communication of data to the ICC workstations at MOC via this barrier, the data is buffered on the Herschel Frame Decommutator (FFRD) that is located on the DDSLAN (see Figure 8). The connectivity for both MCS—FFRD and FFRD—ICC workstations is by means of TCP/IP task to task communication.

This solution allows:

- The ICC equipment not to be directly connected to the OPSLAN
- Access to the ICC workstations from the outside world via global Internet and/ or ISDN lines

The FFRD functionality is as follows:

- Connect to the MCS and the ICC workstations
- Control and manage the links
- Receive and process all Telemetry Frames extracting Housekeeping and Science Telemetry Source Packets
- Forward extracted source packets to the relevant PI s nodes (selected APIDs)
- Provide telemetry selection capability to define and customise the list of packets requested by each PI

The following constraints apply to the FFRD

- There will be no replay capability (i.e. if for any reason delivery of on-line telemetry will fail, no capability to recall the missed telemetry will be supported by the near real-time telemetry distribution infrastructure)
- There will be no data archiving functionality both at transfer frame and at packet level
- Interface to the ICC workstations is a one way interface, i.e. no telecommand interface from the ICC workstation to the MCS will be provided
- There is only one application at a time onto each ICC workstation in charge to receive telemetry source packets at any one time

Two likely implementations of the FFRD can be considered:

1. All received packets (including science data dumped from the SSMM)
2. Real time science packets + those packets processed in real-time by the MCS

The selection of 1 or 2 has to consider the following:

1. The load on the systems dealing with the data traffic (FFRD and ICC@MOC) and hence the cost of the hardware required to deal with the data rates,
2. the response time which is required for reaction to events detected in data which is already old at the time of reception, and which has not been recorded by the instrument as an exception, and
3. the possibility to retrieve the data “offline” from the DDS with an additional time penalty, which can however be optimised by setting the appropriate consolidation time.

3.6.4 RTA

In its ‘playback’ mode the RTA component will function exactly like it will during routine operations; telemetry data will be retrieved from the HCSS and will be analysed using standard RTA functionalities. In this mode the relevant interfaces shall accommodate a data flow corresponding to 10 times the on-board data rate.

In the ‘real-time’ mode RTA will be fed by a telemetry stream directly from the telemetry interface that is connected to the FFRD as described above. Products generated by RTA in ‘real-time’ mode will be stored in the HCSS through standard interfaces.

3.6.5 On-board Software Maintenance (OBSM)

Same as in the routine operations phase, see section 3.1.5.

Patching an instrument OBSW is not a real-time operation and requires validation through an instrument simulator. The OBSM system will therefore not be available at ICC@MOC. In addition, the OBS image can not be directly delivered from the ICC@MOC to MOC, but needs to be delivered via HSC.

3.6.6 MIB editor

Same as in the routine operations phase, see section 3.1.6.

The MIB editor will also be available at ICC@MOC since it could be used in conjunction with RTA and QLA.

3.6.7 HSC—MOC interfaces

The interfaces between the HSC and the MOC will be as during routine operations. See section 3.1.8 for a full description of all interfaces and archive and retrieval functions. Additional information to be passed with respect to the routine operations phase will be handled on an individual ‘per data item’ basis.

3.6.8 ICC@MOC—MOC interfaces

The interface between the ICC@MOC and the MOC is a ‘near real-time’ (NRT) interface contrary to the interface between the HSC and the MOC, which is file based. NRT telemetry data (non-consolidated) is received from the FFRD as a stream based on the TCP/IP protocol and fed into the telemetry interface. The front-end of this interface (the receiver side) is therefore different with respect to the same interface between HSC and MOC.

Alternatively, a second output port is needed to forward the NRT telemetry stream to the RTA ‘real-time’ function. Since RTA is SCOS-2000 based, the interface here must be SCOS-2000 compatible. The telemetry interface will have to be able to cope with the instrument data rate (currently this implies about 400 kbits/s as in the PACS burst mode).

3.6.9 HSC—ICC@ICC interfaces

Same as in the routine operations phase, see section 3.1.5.

3.6.10 ICC@ICC—ICC@MOC interfaces

This interface is in principle the same as between the HSC and the ICC@ICC, i.e. based on the distributed HCSS. Objects created in any of the HSC or ICC will be accessible in a transparent manner to any of the other centres. The HCSS node which is physically located at the ICC@MOC takes care of the distribution (and collection) of all requested data objects. There is no real-time requirement for this interface.

If the ICC@ICC needs near real-time telemetry data for local ICC IA/ QLA (and for local ICC RTA as well) the ICC is responsible for the distribution of near real-time telemetry data from the ICC@MOC to the

ICC@ICC. This could be implemented through the public internet or via dedicated connections that are under the responsibility of the ICCs. The ICCs will get support from the MOC for the set-up of the necessary internet routers at the MOC.

There is also the possibility to use remote login from and to both (or more) ICC centres. This is made possible as the ICC@MOC is outside the ESOC firewall.

3.7 *Calibration/ performance verification phase*

Same as the routine operations phase, see section 3.1 or in early stage as commissioning phase, see section 3.6

3.8 *Science demonstration phase*

Same as the routine operations phase, see section 3.1.

3.9 Post-operations phase

3.9.1 Introduction

In post-operations, the HGS will consist of the HCSS deployed at the HSC and at the ICCs. The MOC will have ceased to be operational. The HGS for post-operations is presented in Figure 18.

3.9.2 HCSS components in post-operations

The HCSS components are the same as in the routine operations phase (see section 3.1) with the following components related to uplink, i.e. CUS and MPS not being used operationally anymore. The PHS will not be used since proposals should not be updated during post-operations.

3.9.3 RTA

Same as in the routine operations phase, see section 3.1.4.

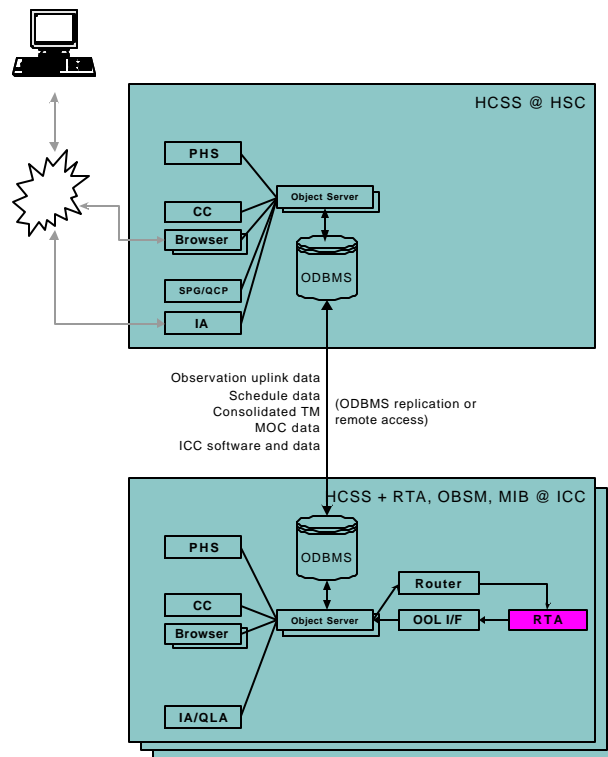

Figure 18: The HGS in post -operations phase

3.9.4 On-board software Maintenance (OBSM)

N/A

3.9.5 MIB Editor

N/A

3.9.6 HSC—ICC interfaces

Same as in the routine operations phase, see section 3.1.9.

4 FEASIBILITY AND RESOURCE ESTIMATES

This section will define the data link required capabilities in in-orbit and post mission phase. This section is TBW.