

SPIRE

SUBJECT: Operating Modes for the SPIRE Instrument

**PREPARED BY: Bruce Swinyard (Custodian)
Matt Griffin
Ken King**

DOCUMENT No: SPIRE-RAL-PRJ-000320

ISSUE: Draft	Date: 12 November 1999
1.0	30 November 1999
2.0	4 April 2000
2.2	25 May 2000
2.3	23 November 2000

CHECKED BY: Christophe Cara Riccardo Cerulli-Irelli Gillian Wright	Date:
---	--------------

APPROVED BY: Matt Griffin Ken King Walter Gear Jean-Paul Baluteau Laurent Vigroux	Date:
--	--------------

Distribution

All SPIRE Co-Investigators and Institute Managers

Change Record

ISSUE	DATE	Comments
Draft	12/11/1999	First proper draft with all sections except 6 and 7
1.0	30/11/1999	Issued Prior to Warm Electronics Review
2.0	04/04/2000	Revised following detector selection
2.1	08/04/2000	Working version for RAL meeting 11 April 2000
2.2	25/05/2000	Updated for PDR
2.3	24/11/2000	Revised version for Systems Design Review, Nov. 30 2000

Table of Contents

1. Introduction.....	7
2. Mission Assumptions.....	7
2.1 FIRST and SPIRE.....	7
2.2 Other FIRST Instruments	8
2.2.1 Mission Operations.....	8
2.2.2 Observe Mode Scenario	8
2.3 Satellite operations	10
2.3.1 Pointing	10
2.3.2 Pointing errors	11
2.3.3 Nod.....	12
2.3.4 Raster.....	12
2.3.5 Line Scan.....	12
3. Overview of Operating Modes.....	14
3.1 OFF Mode.....	14
3.2 Initialise (INIT) Mode	14
3.3 ON Mode	14
3.4 Ready (REDY) Mode	14
3.5 Standby (STBY) Mode.....	14
3.6 Observe Mode (OBSV) Mode.....	14
3.7 Cooler Recycle (CREC) Mode	14
3.8 SAFE Mode	15
3.9 Mode Transition	15
3.10 Non-standard Data Configurations.....	16
3.10.1 Commissioning and Calibration (COCA)	16
3.10.2 Transparent (TRNS).....	16
3.10.3 TEST	16
4. Detailed Operating Modes	16
4.1 Instrument Configuration for Operating Modes	16
4.2 Power Dissipation.....	19
4.3 Telemetry.....	19
4.4 Spacecraft Functions.....	20
4.5 Operations Timelines.....	21
4.5.1 OFF to STANDBY	22
4.5.2 STANDBY to OFF.....	22
4.5.3 Switching to SAFE.....	23
4.5.4 Cooler Recycling.....	23
5. Observatory Functions.....	24
5.1 Observatory Functions for the Photometer.....	24
5.1.1 POF1: Chop Without Jiggling.....	25
5.1.2 POF2: Seven-Point Jiggle Map	29
5.1.3 POF3: n-Point Jiggle Map.....	31
5.1.4 POF4: Raster Map	34
5.1.5 POF5: Scan Map Without Chopping.....	36
5.1.6 POF6: Scan Map With Chopping.....	38
5.1.7 POF7: Photometer Peak-Up	39
5.1.8 POF8: Photometer Calibrate.....	40
5.2 Observatory Functions for Spectrometer.....	41
5.2.1 SOF1: Point Source Spectrum.....	41
5.2.2 SOF2: Fully Sampled Spectral Map within FOV.....	42

6. Degraded Operations	44
Automatic Cooler Recycling	44
Slow Chop Mode	44
BSM Open Loop.....	44
Single Axis BSM Operation	44
Slow scanning of the FTS mirrors	44
Step and look operation	44
Open loop operation of the FTS mechanism	45
Selection of pixels for telemetry.....	45
Spectrometer Operation without calibrator	45

Glossary

AIV	Assembly Integration and Verification
AOCS	Attitude and Orbit Control System
ASIC	Application Specific Integrated Circuit
AVM	Avionics Model
BSM	Beam Steering Mechanism
CDMS	Command and Data Management System (on Spacecraft)
CQM	Cryogenic Qualification Model
CVV	Cryostat Vacuum Vessel
DPU	Digital Processing Unit
DRU	Detector Readout Unit
EMC	Electromagnetic Compatibility
EMI	Electromagnetic Interference
FINDAS	FIRST Integrated Network and Data Archive System
FOV	Field of View
FPU	Focal Plane Unit
FS	Flight Spare
FTS	Fourier Transform Spectrometer
HIFI	Heterodyne Instrument for FIRST
ICU	Instrument Control Unit
IID-A	Instrument Interface Document part A
IID-B	Instrument Interface Document part B
JFET	Junction Field Effect Transistor
MGSE	Mechanical Ground Support Equipment
NEP	Noise Equivalent Power
OBDH	On Board Data Handling (on Spacecraft)
OGSE	Optical Ground Support Equipment
OPD	Optical Path Difference
PACS	Photometer Array Camera and Spectrometer
PDU	Power Distribution Unit (on spacecraft)
PFM	Proto-Flight Model
PLM	Payload Module
POF	Photometer Observatory Function
QLF	Quick Look Facility
S/C	Space Craft
SOF	Spectrometer Observatory Function
SPIRE	Spectral and Photometric Imaging Receiver
SRD	Science Requirements Document
SVM	Service Module
TBD	To Be Determined
TBC	To Be Confirmed

References

Applicable Documents

AD1	FIRST-Planck IID-A	SCI-PT-IIDA-04624 Issue 0-4 21 June 2000
AD1	Instrument Requirements Document	SPIRE/RAL/N/0034 Issue 1.0 24 November 2000

Reference Documents

1. INTRODUCTION

This document describes the expected operating modes for the SPIRE instrument on FIRST. It gives a detailed description of the operations required to implement each operating mode in order to place requirements on the components of the SPIRE instrument other than the cold FPU – i.e. the warm electronics; on-board software and ground segment. The underlying assumption in this document is that the configuration of the instrument cold FPU is as defined in AD2, the *SPIRE Instrument Requirements Document* (IRD). This document describes how the sub-systems defined in the IRD are to be operated; it is not intended to place further requirements on the cold FPU sub-systems.

Section 2 gives the assumptions underlying the description of the operating modes and the expected conditions for the satellite operations. Section 3 is a brief description of each of the operating modes and how the instrument is switched from one mode to another; section 4 goes into more detail. Section 5 describes the observatory functions that are required to implement the SPIRE observations. Section 6 deals with possible degraded instrument operation due to sub-system failure. Section 7 details the instrument functions and data configurations required to carry out all SPIRE operating modes.

2. MISSION ASSUMPTIONS

2.1 FIRST and SPIRE

The Far Infrared and Submillimetre Telescope (FIRST) mission is dedicated to observing the cosmos at wavelengths from 85 to 700 μm . It consists of the 3.5 m telescope at a temperature of 80 K with a suite of focal plane instruments cooled to <11 K in liquid helium cryostat. A service module (SVM) is provided on the satellite for the instrument warm electronics units and the satellite control systems.

The SPIRE instrument is one of three focal plane instruments for FIRST. It will make observations in the 200 to 670 μm band using bolometer detectors. The focal plane unit of SPIRE is operated at cryogenic temperature (< 11 K) and the detectors are operated at ~300 mK. This temperature is provided by a ^3He sorption cooler.

The instrument consists of two sub-instruments:

SPIRE-P: A three band imaging photometer using three separate bolometer arrays with fixed optical band pass filters with resolution of about 3. This will simultaneously image a 4x8 arcmin (TBC) field of view onto three bands centred on 250, 350 and 500 μm (TBC). A beam steering mirror will be used to move the image of the sky over the arrays to chop the field view of the instrument onto the sky background close to the object of interest and to give complete spatial sampling of the field of view by stepping the image by fractions of the Airy pattern diameter.

SPIRE-S: An imaging Fourier Transform Spectrometer (FTS). This uses two bolometer arrays to give spectrally resolved images of a small (~2.6 arcmin (TBC)) area of sky. The two bolometer array have nominal optical bands of 200-300 and 300-400 μm , with a possible extension to 670 μm . The maximum resolution of the instrument will be about 0.04 cm^{-1} . The spectrometer shares the input optics to the instrument with the photometer. This includes the beam steering mirror which can be used to step the image across the arrays to give full spatial sampling of the field of view.

It is assumed that the photometer and spectrometer will be operated independently.

2.2 Other FIRST Instruments

There are two other instruments on FIRST:

HIFI (The Heterodyne Instrument for FIRST): A heterodyne spectrometer to give very high resolution spectroscopy over the 2700 to 480 GHz frequency band.

PACS (Photo-conductor Array Camera and Spectrometer): A broadband imaging photometer and medium resolution imaging spectrometer operating over the 85 – 200 μm waveband.

The HIFI cold FPU and local oscillators will be switched off during all SPIRE observations. It is possible that SPIRE will be used to take simultaneous images with the PACS instrument, with PACS as PRIME and SPIRE operating in PARALLEL mode (see minutes of FST5). SPIRE can also operate in SERENDIPITY mode, taking data while the telescope is slewing.

2.2.1 Mission Operations

The following assumptions are made about how FIRST/SPIRE will be operated:

- FIRST will operate autonomously with no real time monitoring of the telemetry on the ground, except during the data transfer periods.
- FIRST will be out of ground contact for 21 out of every 24 hours.
- All instrument data will be passed into the satellite on board solid state recorders at an average rate of no more than 100 kbit/sec averaged over 24 hours (TBC).
- When the spacecraft is out of ground contact, the instrument will be responsible for its own health and safety monitoring and will be capable of switching to a defined safe mode in the event of a detected anomaly. The spacecraft will also monitor the instrument and will switch the instrument to a pre-defined safe mode in the event of a detected anomaly in the DPU operation.
- Nominal ground contact will be for 3 out of every 24 hours.
- During ground contact all data will be transferred from the satellite solid state recorders to the ground station and the commands for the next 24 hours of operations will be uplinked.
- When not being actively used SPIRE will be switched to a standby mode.
- The default operating scenario is for SPIRE to be left on at all times to preserve the on-board software and configuration data in the instrument volatile memory.

2.2.2 Observe Mode Scenario

Figure 2-1 shows the assumed model for the definition of the SPIRE observations and the method by which the astronomer inputs his/her observing programme. The elements of the model are as follows:

- **AOT** (Astronomical Observation Templates): The observer is given a choice of observation types that can be carried out by the instrument and telescope. These will be limited to no more than ten (TBC). He/she is given a template to fill in with the details of the sources to be observed and the parameters for the particular observation. At this stage the parameters are in astronomical terms – source name; RA, DEC; signal-to-noise; area to mapped; spectral range and resolution etc.
- **Observation:** The First Science Centre (FSC) takes the inputs from the astronomer via the AOT and is responsible for their conversion into OBSERVATORY FUNCTIONS with parameters for the SPACECRAFT FUNCTIONS; INSTRUMENT FUNCTIONS and INSTRUMENT DATA CONFIGURATIONS that make up the OBSERVATORY FUNCTIONS. The OBSERVATORY FUNCTION is a template which, when instantiated with the actual parameters for a given source and

observation type, becomes an OBSERVATION of fixed time length which can be scheduled into an OBSERVING SEQUENCE.

- **Observing Sequence:** The OBSERVATIONS required for a particular programme are put together into an OBSERVING SEQUENCE to be implemented by the MOC. The scheduling of the OBSERVING SEQUENCE is defined by the FSC and implemented by the MOC.
- **Observatory Function:** A combination of SPACECRAFT and INSTRUMENT FUNCTIONS and DATA CONFIGURATIONS which, with the appropriate input parameters, allow any OBSERVATION to be carried out.
- **Spacecraft Functions:** These are the operations that can be carried by the spacecraft to point the telescope such as line scan; raster; staring etc They are fully described in AD1 (*FIRST Scientific Pointing Modes*) – for information they are summarised in section 2.4. Spacecraft functions also include operations by the spacecraft on-board data handling sub-system (CDMS) to switch power to the instrument; send commands; collect data etc.
- **Instrument Functions:** These are the operations to be carried out with the instrument such as PHOTOMETER CHOP; PHOTOMETER JIGGLE; SPECTROMETER SCAN etc. Combined with the SPACECRAFT FUNCTIONS they fully define how an observation is to be carried out.
- **Instrument Data Configuration:** In addition to specifying how the instrument is to be operated for a given operation, the on-board data processing needs to be specified along with the data to be sampled and the manner in which the detector data is sampled. This will be done by choosing from a number of DATA CONFIGURATIONS such as PHOTOMETER FULL FIELD; SPECTROMETER SINGLE PIXEL etc etc.
- **Instrument Command Sequences:** The instrument will be operated by building the high level instrument functions from a command language built up of INSTRUMENT COMMAND SEQUENCES. These are an intermediate set of logical instrument control functions such as CHOP START or READ PHOTOMETER FRAME that allow the instrument controllers to build any required INSTRUMENT FUNCTIONS without resort to low level commands.
- **Instrument Commands:** This is the low level command language used to control the instrument (Note change name in diagram)

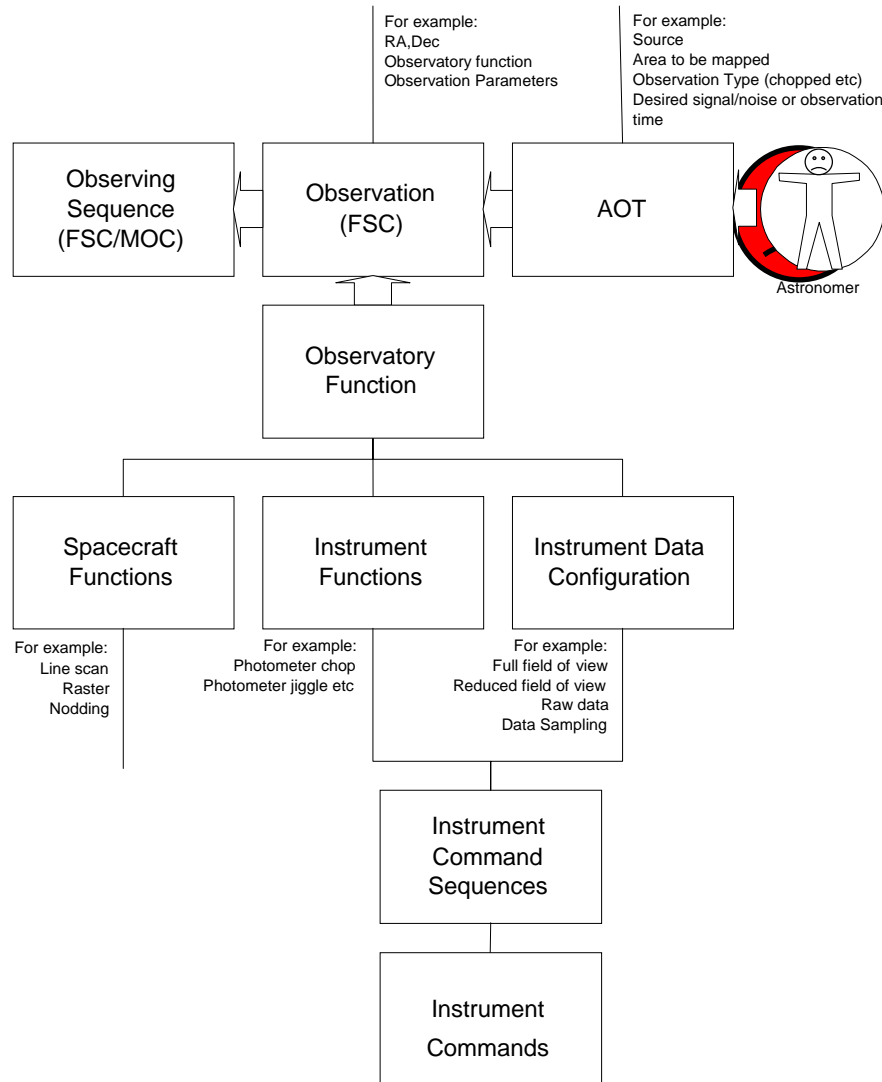

Figure 2.1: Diagrammatic representation of the connection between the various elements for the implementation of the SPIRE Observe Mode

2.3 Satellite operations

This section describes the operations assumed to be available from the satellite and required by the SPIRE instrument for the pointing of the telescope. Full details of the spacecraft capabilities are given in AD1. See section 5 for more details on the implementation and the scientific merit of these operations.

2.3.1 Pointing

It is assumed that SPIRE pointing will be defined with respect to the telescope boresight by two offset positions, one for the centre of the photometer arrays and one for the centre of the spectrometer arrays, as shown below. When the telescope is pointed at a source at the request of SPIRE, it shall be aligned

on one of the two positions defined in Fig. 2.2 below. Any offsetting by the SPIRE BSM or the AOCS shall then be defined with respect to this position.

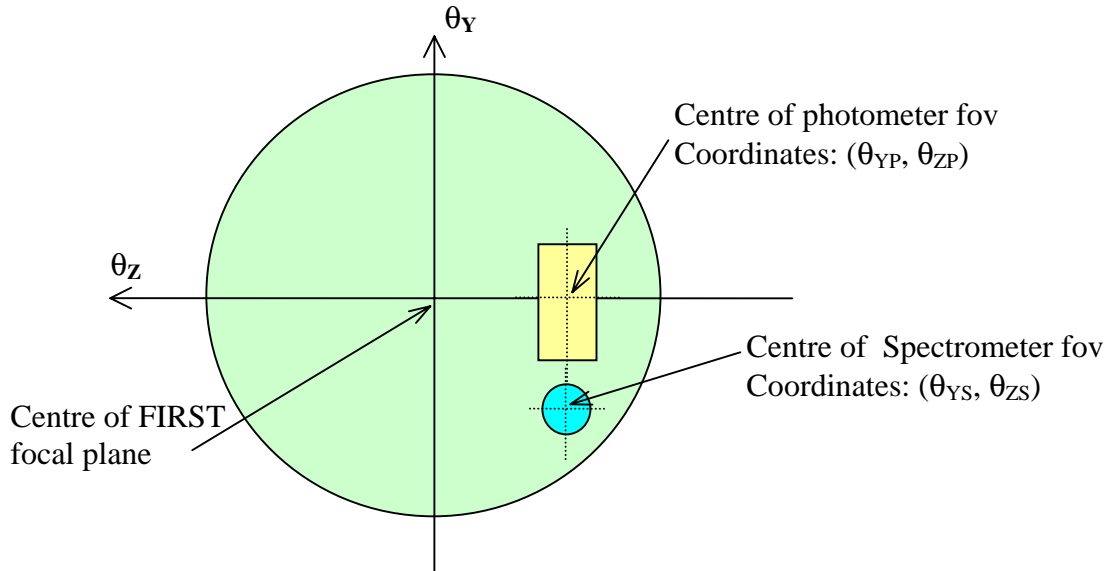

Figure 2.2: Definition of SPIRE pointing offsets with respect to the telescope boresight.

2.3.2 Pointing errors

The FIRST/Planck IID-A provides the following information on the telescope pointing accuracy.

Absolute Pointing Error (APE): The angular separation between the commanded direction and the instantaneous actual direction.

Pointing Drift Error (PDE): The angular separation between the short time average (barycentre of the actual pointing during some time interval) and a similar average pointing at a later time. The drift is given over 24 hours during the same observation period.

Relative Pointing Error (RPE): The angular separation between the instantaneous orientation of the satellite fixed axis at some time t and a reference axis (average, barycentre) over defined period. This is also known as the pointing stability.

Attitude Measurement Error (AME): The angular separation between the actual and the measured orientation of the satellite fixed axis defined instantaneously. This performance requirement is referred to as "a posteriori knowledge".

Absolute Rate Error (ARE) : The angular rate separation between the actual and the controlled angular rate about the satellite spin axis.

APE:	Required 3.7"	Goal 1.5"
RPE (1 min pointing)	Required 0.3"	Goal 0.3"
RPE (1 min scanning)	Required 1.2"	Goal 0.8"
AME (pointing)	Required 3.1"	Goal 1.2"
AME (scanning)	Required 5.0"	Goal 1.4"
AME (slewing)	Required 10"	Goal 1.5"

These figures are specified at a temporal probability level of 68% (i.e., the error will be within the specified value for more than 68% of the time).

2.3.3 Nod

The NOD function of the telescope is an operation in which the target source is periodically moved from one instrument chop position to the other chop position by re-pointing the satellite. The pointing direction will change in the direction of the chopper throw – see Fig. 2-2.

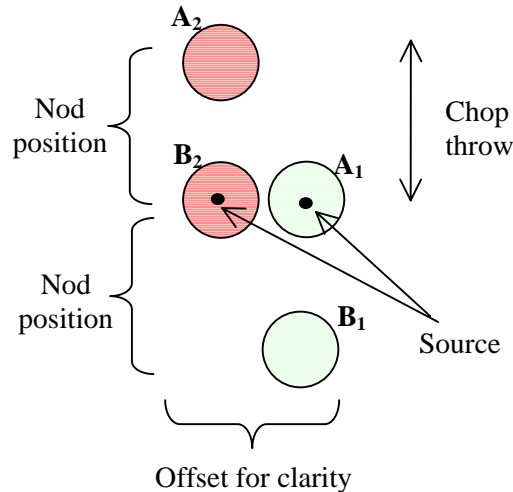

Figure 2.3: Pointing positions for a telescope NOD function. The circles represent the size of the telescope Airy pattern projected onto the sky. The two nod positions have been offset left and right for clarity. In reality A₁ and B₂ would be co-aligned

2.3.4 Raster

The RASTER Spacecraft Function is a series of fine pointing operations of separated by slews such that the pointing of the telescope axis moves in a raster pattern. Figure 2-3 shows how the raster pattern will be constructed.

2.3.5 Line Scan

In the LINE SCAN Spacecraft Function the satellite is slewed at a constant angular velocity along short parallel lines on the sky. Figure 2-4 shows how the operation is carried out.

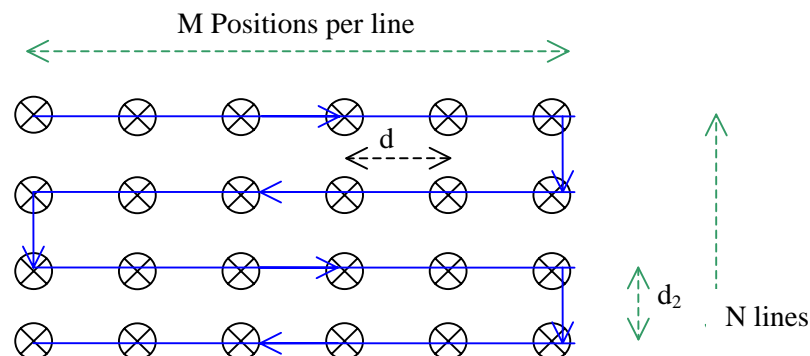

Figure 2.4: Pointing positions for a telescope RASTER function. The observation is specified in terms of M pointings per line separated by d_1 by N lines separated by d_2 arcsec.

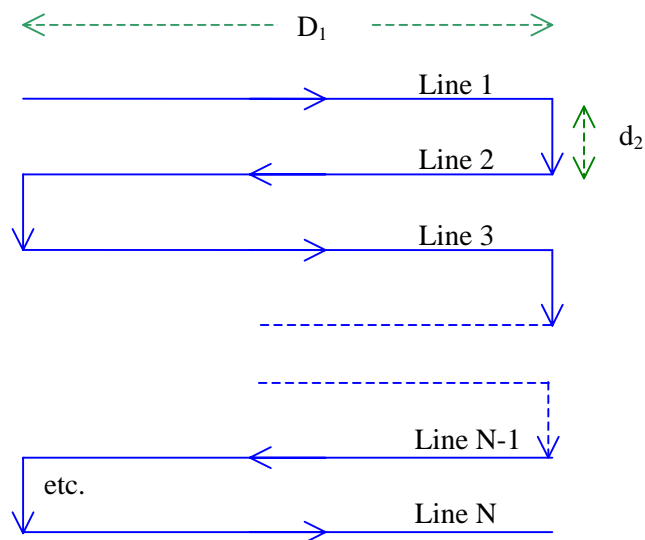

Figure 2.5: The LINE SCAN function of the telescope consists of a number of short slews of length D_1 separated by a distance d_2 . The slews will be carried out in the order shown here

3. OVERVIEW OF OPERATING MODES

This section gives a brief description of the operating modes for the SPIRE instrument identified in the *Instrument Requirements Document (AD2)*. Note that this list has been expanded to include the SAFE; INIT; TRNS; and TEST modes. An acronym of no more than four letters is given to each mode for identification purposes later in the document.

3.1 OFF Mode

All instrument sub-systems will be switched off - including the DPU and there will be no instrument telemetry.

3.2 Initialise (INIT) Mode

This is an intermediate mode between OFF and ON. This will be the mode the instrument enters after a power on or re-boot. In this mode only a limited sub-set of commands may be executed. This mode allows updates of DPU on-board software and/or tables to be carried out safely before they are used for instrument control.

3.3 ON Mode

The DPU will be switched on and can receive and interpret all instrument commands, but no other sub-systems will be switched on (including the DRCU). For engineering purposes it will be possible to command the instrument to switch on individual sub-systems from this mode. Full DPU housekeeping data will be telemetered.

3.4 Ready (REDY) Mode

The DPU and DRCU are powered on and the on-board software is ready to receive commands. No other sub-systems are switched on in this mode. DRCU housekeeping data will be telemetered.

3.5 Standby (STBY) Mode

The spacecraft may be pointed in an arbitrary direction (observing with another instrument for instance). The instrument will telemeter only housekeeping information, and perhaps some degraded science data - see below, at a rate very much lower than the full telemetry bandwidth. This is presently baselined to be the photometer detectors on and at 300 mK i.e. the cooler will have been recycled previous to entering STANDBY. All other sub-systems will be switched off.

3.6 Observe Mode (OBSV) Mode

There are two basic sub-modes for the observe mode Photometer and Spectrometer. The details of the OBSERVATIONS to be carried out in OBSERVE mode are given in section 5.

3.7 Cooler Recycle (CREC) Mode

The ^3He cooler requires recycling every 46 hours (TBC). During this time the instrument will be switched off except for vital housekeeping and cooler functions (TBC). The recycling takes 2 hours (TBC) to complete with another N hours (TBD) before instrument operations can recommence. During the 2 hours recycling the heat load on the helium bath is 50-100 mW (TBC).

3.8 SAFE Mode

The instrument will be switched to SAFE mode in the event of any anomalous situation occurring whilst in autonomous operation. This will be with the DPU on having been rebooted from a restricted set of software stored in ROM.

3.9 Mode Transition

Figure 3-1 shows the logical transition from one operating mode to another.

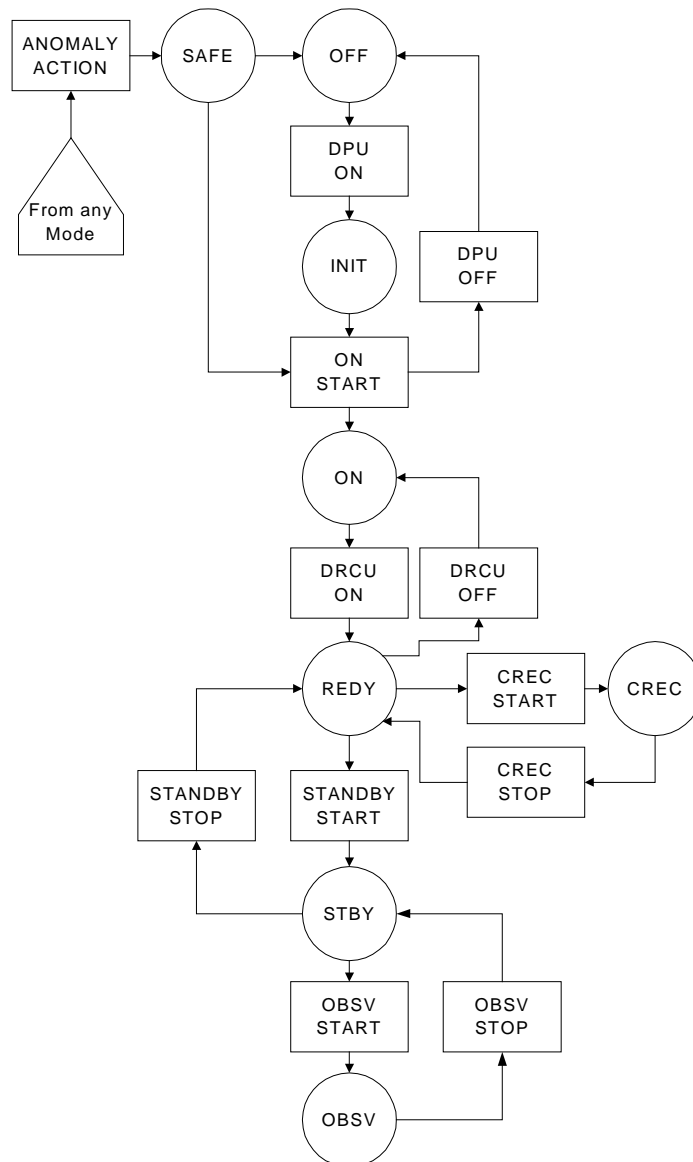

Figure 3.1: Logical transition flow between SPIRE operating modes. The boxes represent instrument command sequences to switch a mode on. The naming convention applied is UNIT_VERB and MODE_VERB with START and STOP for modes and ON and OFF for units.

3.10 Non-standard Data Configurations

In this section the data configurations that will be required for testing and commissioning the instrument both on the ground and in-flight are briefly described.

3.10.1 Commissioning and Calibration (COCA)

During the commissioning and performance verification phases of mission operations, many housekeeping and other health check parameters will be unknown; poorly defined or under investigation. This configuration allows the limits on selected health check parameters to be ignored by whatever real time monitoring systems are in place on the spacecraft or instrument.

3.10.2 Transparent (TRNS)

This can be used for any operating mode that utilises on-board processing or data compression. All on-board processing is switched off and the telemetry stream is filled with “raw” data from the detectors; mechanisms etc.

3.10.3 TEST

Here a fixed configuration of the instrument is used to generate a known set of data. It will be used during integration and verification for de-bugging the interface between the instrument and the spacecraft. It will also be useful in-flight for testing the system after switch on or after an anomaly.

4. DETAILED OPERATING MODES

4.1 Instrument Configuration for Operating Modes

Table 4.1-1 shows a matrix between the defined operating modes and the actions to be carried out by the SPIRE instrument. The instrument actions are as defined below. This top-level matrix gives an indication of what actions are possible in a given operating mode and at the same time what sub-systems are to be operated. The OBSERVE MODE is not broken down into the separate INSTRUMENT FUNCTIONS – see section 5. This means that the table shows both spectrometer and photometer elements being used for all observations – this will not be the case as the two sub-instruments will not be used together.

Instrument Action	Operating Mode							
	OFF	INIT	ON	REDY	STBY	CREC	OBSV	SAFE
DPU Commanding	No	Yes	Yes	Yes	Yes	No	No	Yes
Instrument Command Decoding and Execution	No	No	No	Yes	Yes	Yes	Yes	No
Housekeeping Acquisition	No	Yes	Yes	Yes	Yes	Yes	Yes	Yes
Data Formatting	No	Yes	Yes	Yes	Yes	Yes	Yes	Yes
Telemetry Sending	No	Yes	Yes	Yes	Yes	Yes	Yes	Yes
Fridge Recycle Control	No	No	No	No	No	Yes	No	No
Fridge Heater Control	No	No	No	No	No	No	Yes	No
FPU Temperature Regulation	No	No	No	No	Yes?	No	Yes	No
Photometer Detector Control	No	No	No	No	Yes?	No	Yes*	No
Spectrometer Detector Control	No	No	No	No	No	No	Yes*	No
Photometer Calibration Source Control	No	No	No	No	No	No	Yes*	No
Spectrometer Calibration Source Control	No	No	No	No	No	No	Yes*	No
FTS Mechanism Control	No	No	No	No	No	No	Yes*	No
Beam Steering Mirror Control	No	No	No	No	No	No	Yes*	No

Table 4.1: Instrument operations possible or required for each SPIRE operating mode.

*Which sub-system is used depends on the particular observation

Instrument Action Definitions

Commanding:

There will be three types of instrument action associated with telecommands:

DPU Commanding: Commands will be sent just to the DPU to do something to itself – RAM/ROM Dump; RAM patches etc

Instrument Commanding: Higher level procedure commands sent to DPU – basically the INSTRUMENT FUNCTIONS – which it interprets into low level commands to the DCRU. The commands to the DRCU are to make the sub-systems perform some action – scan the FTS, move the BSM etc and for the DRCU to sample any of the channels (detectors; position sensors; temperatures etc) and send the data to the DPU.

Housekeeping Acquisition:

Taking housekeeping parameters from the appropriate sub-systems and sticking into the appropriate HK packet – i.e. might be one for DPU and another for the DCRU etc.

Data Formatting:

Action of DPU in collating data from sub-systems and any on board processing and placing it into the appropriate packets with time stamping; headers etc.

Telemetry Sending:

Action of DPU in responding to the S/C CDMS request for data from SPIRE and sending it.

Fridge Recycle Control:

Operation of Warm Electronics to switch ^3He cooler heat switches and heaters on and off as appropriate to recycle the fridge

Fridge Heater Control:

Action of the Warm Electronics to operate the ^3He fridge by adjusting the current flowing through the pump heater to keep the cold tip temperature constant.

FPU Temperature Regulation:

Action of the Warm Electronics to maintain constant temperature of what ever bits of the cold FPU are temperature controlled by using PID type feedback between thermometers and heaters. May NOT be implemented.

Photometer Detector Control:

Action of the DPU to request a number of frames of photometer detector data from the DRCU at a given rate. The frames will consist of all or fewer of the available detector channels depending on the data configuration required. The DRCU will then send the appropriate data to the DPU. The DPU receives the data into memory for data formatting.

Spectrometer Detector Control:

Action of the DPU to request a number of frames of spectrometer detector data from the DRCU at a given rate. The frames will consist of all or fewer of the available detector channels depending on the data configuration required. The DRCU will then send the appropriate data to the DPU. The DPU receives the data into memory for data formatting.

Photometer Calibration Source Control:

Action of the DPU to request the DRCU to switch on the photometer calibration source. The control of the calibration source may be done by repeated commands from the DPU to the DRCU to change the calibration source state or may be done under the direct control of the DRCU. This will include modulating the current through the device at the appropriate rate – up to 5 Hz (TBC).

Spectrometer Calibration Source Control:

Action of the DPU to request the DRCU to switch on the spectrometer calibration sources. The control of the calibration source will be done by repeated commands from the DPU to the DRCU to change the calibration sources states. It is expected that the sources will be operated as DC devices with no short period modulation required.

FTS Mechanism Control:

Action of the DPU to request the DRCU to scan the FTS mechanism followed by action of the DCRU to move the FTS mirrors by controlling the position with whatever feedback loop between the position sensor and the linear motor.

Beam Steering Mirror Control:

Action of the DPU to request the DRCU to move the beam steering mechanism followed by action of the DCRU to move the BSM by controlling the position with whatever feedback loop between the position sensor and the linear motor. The chopping and jiggling of the BSM will be controlled by direct command from the DPU to the DRCU to change the BSM state.

4.2 Power Dissipation

In this section the global power dissipation figures for each mode for the warm electronics units and the various cryogenic stages are given. The situation for the OBSERVE mode is complicated as it will depend on the precise INSTRUMENT FUNCTION being used and which detector option is chosen. OBSERVE MODE is there fore treated separately in section 5.

Dissipating Sub-System	Operating Mode						
	OFF	INIT	ON	REDY	STBY	COOL	SAFE
DPU	0	15 W	15 W	15 W	15 W	15 W	15 W
DCRU	0	0	0	TBD	71 W	TBD	0
Detectors (15 K)	0	0	0	0	33 mW	0	0
Detectors (4 K)	0	0	0	0	0	0	0
Detectors (2 K)	0	0	0	0	0	0	0
Parasitics (4-K)	4 mW	4 mW	4 mW	4 mW	4 mW	4 mW	4 mW
Parasitics (2 K)	2.5 mW	2.5 mW	2.5 mW	2.5 mW	2.5 mW	2.5 mW	2.5 mW
Cooler Heater	0	0	0	0	0	100 mW	0

Table 4.2: Estimated power dissipation for all operating modes except OBSV.

All figures in this table are subject to revision.

4.3 Telemetry

In this section the expected telemetry contents and rate for each operating mode are discussed except for the OBSERVE mode – again this is complex and is dealt with in section 5. The contents of the TELEMETRY CONFIGURATIONS that will be used for the different operating modes are indicated in table 4-3.1. Detailed discussion of the packet construction and contents for these configurations is beyond the scope of the present document, except to note that the telemetry contents listed here do not necessarily have a one to one correspondence with the packet contents. Table 4-3.2 lists TELEMETRY CONFIGURATIONS that will be used for each of the operating modes. The entries in this table are the estimated telemetry rate for the mode in kbit/second.

Telemetry Configuration	Telemetry Contents
DPU Housekeeping	DPU Internal Supply Voltages DPU Internal Supply Currents DPU Temperatures Specific DPU OBS flags for example: Command received counter Command executed counter Current command buffer contents Memory status Commands sent counter etc, etc
Instrument Housekeeping	DRCU Internal Supply Voltages DRCU Internal Supply Currents DRCU Internal Temperatures Instrument status flags – e.g. sub-system X redundant coil Y is ON etc etc.... Sub-system voltages; currents; counters etc. Cold FPU and JFET box temperature channels

Serendipity	We assume that serendipity mode is with SPIRE prime – therefore we will take the full telemetry bandwidth with the photometer detectors
Parallel	This is with SPIRE non-prime. We will send down our standard housekeeping plus some portion of the photometer detectors at a low rate depending on the telemetry bandwidth available

Table 4.3: Brief description of TELEMETRY CONFIGURATION contents.

Telemetry Configurations	Operating Mode						
	OFF	INIT	ON	REDY	STBY	CREC	SAFE
DPU Housekeeping	No	~0.5 kbps	~0.5 kbps	~0.5 kbps	~0.5 kbps	~0.5 kbps	~0.5 kbps
Instrument Houskeeping	No	No	No	~0.5 kbps	~3.5 kbps	~3.5 kbps	No
Serendipity	No	No	No	No	~87 kbps	No	No
Parallel	No	No	No	No	TBD	No	No

Table 4.4: Expected data configurations and telemetry rates for all operating modes except OBSV. All figures are TBC.

4.4 Spacecraft Functions

This section describes gives the expected spacecraft operations that are or may be required to be enacted for each operating mode – again the OBSERVE MODE is complex and is dealt with in section 5. For most of the modes listed here the Spacecraft Functions routinely required are likely to be minimal. The ability of the s/c to switch SPIRE to SAFE is needed for all modes except INIT and OFF. The titles of the procedures which call these Spacecraft Functions are given in square brackets and correlate to figure 3-1.

Switch SPIRE from OFF to INIT [DPU ON]

The spacecraft switches the 28 V line to the DPU on. This can only be enacted by a direct command to the spacecraft – by definition the SPIRE instrument cannot request itself to be switched on!

Switch SPIRE from ON to REDY [DRCU ON]

The spacecraft switches the 28 V line to the DCRU on. This will be a direct command to the spacecraft either from the ground or as part of an automated switch on sequence. It is expected that any automated switch on sequence would involve a confirmation of instrument status from the DPU to the CDMS before the 28V to the DRCU was switched on.

Switch SPIRE from REDY to ON [DRCU OFF]

The spacecraft switches the 28 V line to the DCRU off. This could be requested either by the DPU or by direct command to the spacecraft.

Switch SPIRE from ON to OFF [DPU OFF]

The spacecraft switches the 28 V line to the DPU off. This could be requested either by the DPU or by direct command to the spacecraft.

Switch SPIRE to SAFE [ANOMALY ACTION]

The spacecraft switches the 28 V line to the DRCU off. This may be requested by the DPU or in response to an anomaly detected by the spacecraft CDMS.

Hardware Reset of the DPU (TBD)

The spacecraft will have the ability to enact a hardware reset of the DPU that will, effectively, switch the DPU to SAFE mode whereby it is operating using a restricted set of software located in ROM. This mode allows the contents of the RAM and mass memory to be retained for diagnostic purposes in the event of DPU latch up or other failure, unlike simply switching off the DPU 28-V power supply. The need for this mode is TBD.

Monitor SPIRE Temperature

A number of the S/C temperature sensors are close to both the SPIRE cold FPU and the SPIRE warm electronics units. The spacecraft may be required to take certain actions (e.g. Switch SPIRE to SAFE) if these temperatures go outside pre-defined limits.

Receive SPIRE Data

In all modes except OFF the SPIRE DPU will be making telemetry packets available for on-board storage in the spacecraft Solid State Recorders (SSRs) prior to telemetry to the ground. It is expected that the spacecraft will be collecting these regularly from the SPIRE instrument to prevent overload of the instrument on-board storage capabilities. The regularity with which the data must be collected will depend on the operating mode.

Send SPIRE Commands

In all modes except OFF the SPIRE DPU will be capable of receiving and interpreting commands from the spacecraft CDMS. The spacecraft will pass these to the instrument in a predefined sequence at predefined times, or in response to an instrument status confirmation from the DPU, to ensure the correct operation of the instrument operating mode. The SPIRE instrument will execute the commands in the order they are received and at the time they are received.

Instrument Parameter Monitoring

The spacecraft will monitor the voltage and current of the power supply to the DPU and DCRU. It will also be given knowledge of the instrument configuration by the DPU providing instrument “context” information in the SPIRE housekeeping. The spacecraft will take specific action (e.g. Switch SPIRE to SAFE) if an out of limits anomaly is detected for the DPU or DCRU power supply.

Instrument Event Monitoring

Events detected by the DPU during autonomous operation and which require action by the s/c will be notified to the CDMS via a dedicated “Event Packet”. The CDMS is expected to monitor these and take a pre-set action when a particular event is detected – notably a “Go to SAFE” flag in an event packet.

4.5 Operations Timelines

There are requirements on the timing and status verification of certain instrument or spacecraft actions when going from one operating mode to another. There are also requirements on the timing and status verification of instrument and spacecraft actions within the execution of a given operating mode – most notably the OBSERVE MODE, but also the cooler recycling operation.

In this section the transitions from one mode to another up to STANDBY mode are described as well as the operation of the cooler recycling. The transition from STANDBY to OBSERVE and the OBSERVE mode operations are described in section 5.

4.5.1 OFF to STANDBY

In this section the logical sequence and status confirmation requirements for switching the instrument from OFF to STANDBY MODE are described. In doing so all the “forward” transitions between all modes is described except for between STANDBY/OBSERVE; READY/COOLER RECYCLE and from any mode to SAFE. The transition from OFF to STANDBY may be carried out by the execution of a sequence of **On-Board Command Procedures (OBCP)** and the appropriate, automatic, verification and status confirmations or by direct commands from the ground during ground contact with confirmations in real time by the spacecraft operators.

Initial Instrument State	Procedures	Events/verification	Final Instrument State
OFF	DPU ON	<ol style="list-style-type: none"> 1. Current to instrument stable at TBD A – verified by S/C 2. DPU boots from ROM 3. INIT mode data configuration starts – housekeeping packets generated 4. Confirmation of DPU status from DPU housekeeping 	INIT
INIT	ON START	<ol style="list-style-type: none"> 1. DPU RAM load 2. ON mode data configuration starts 3. RAM dump content verification 4. Confirmation of DPU status from DPU housekeeping <i>(See also the PACS document on how the DPU is started up PACS-CR-TN-002)</i> 	ON
ON	DRCU ON	<ol style="list-style-type: none"> 1. Current to DCRU stabilises at TBD A – verified by S/C 2. DRCU boots from ROM 3. REDY mode data configuration starts 4. Confirmation of DCRU status from DRCU housekeeping 	REDY
REDY	STANDBY START	<ol style="list-style-type: none"> 1. STANDBY mode data configuration started i.e. Science data transfer from DCRU to DPU; STANDBY mode science data formatting started etc 2. Photometer detectors switch on 3. Confirmation of instrument status from DPU; DRCU and instrument housekeeping 	STBY

Table 4.5: SPIRE switch on sequence from OFF to STBY.

4.5.2 STANDBY to OFF

Table 4.5-2 describes the sequence of command procedures and events for switching the SPIRE instrument from STANDBY to OFF. Again this sequence could be generated by a single command to the spacecraft to switch the instrument off – e.g. at the end of an observing period – in which case the sequence could follow automatically with the appropriate status confirmations. Alternatively each step could be initiated by a direct command during ground contact.

Initial Instrument State	Command Procedures	Events/verification	Final Instrument State
STBY	STANDBY STOP	<ol style="list-style-type: none"> 1. DPU switches off all sub-systems 2. REDY mode data configuration starts 3. Verification that all sub-systems are switched off from instrument housekeeping 	REDY
REDY	DRCU OFF	<ol style="list-style-type: none"> 1. Current to DCRU falls to below TBD Amps 2. ON mode data configuration starts 3. Confirmation of DRCU status from DPU and s/c housekeeping 	ON
ON	DPU OFF	<ol style="list-style-type: none"> 1. Current to DPU falls to below TBD Amps 2. Confirmation of DPU from s/c housekeeping 	OFF

Table 4.6: SPIRE procedures for switch off sequence

4.5.3 Switching to SAFE

In this section the actions taken following an instrument anomaly whilst in autonomous operation are outlined. It is assumed that switching from any mode to SAFE is always going to be initiated by the DPU.

Initial Instrument State	Command Procedure	Events/verification	Final Instrument State
OBSV STBY REDY COOL	N/A	<ol style="list-style-type: none"> 1. Hard out of limits or other anomaly (DRCU watchdog etc) detected by on-board software 	N/A
OBSV STBY REDY COOL	ANOMALY ACTION	<ol style="list-style-type: none"> 1. DPU sends commands to DRCU to attempt to switch all sub-systems to off as gracefully as possible 2. DPU sets "Go to SAFE mode" flag in telemetry 	Not Determined
Not Determined	SAFE START	<ol style="list-style-type: none"> 1. DRCU current falls below TBD Amps 2. Confirmation that DRCU is off from s/c housekeeping 3. DPU resets using restricted (ROM) software 4. SAFE mode data configuration starts 	SAFE

Table 4.7: Switching to SAFE mode

4.5.4 Cooler Recycling

The cooler is recycled by the following actions:

1. Switch on the cooler evaporator heat switch by applying current to the heat switch sorption pump heater pushing the gas from the pump into the body of the switch
2. Switch on the cooler pump heater and control the pump temperature according to an OBS routine

3. Wait for a preset time interval for the gas to desorb and condense into the evaporator (N hours)
4. Switch off the pump heater current.
5. Switch off the evaporator heat switch by switching off the current to the heat switch sorption pump heater. As the pump cools the gas in the body of the switch will be re-adsorbed into the pump.
6. Switch on the pump heater heat switch
7. Wait for the pump to cool and the temperature on the evaporator cold tip to fall to the operating temperature.
8. When the operating temperature has been reached the cooler recycle is completed and the instrument can be switched to STANDBY.

Table 4.8 describes the actions and events required for the cooler recycle mode.

Initial Instrument State	Procedure	Events/verification	Final Instrument State
REDY	CREC START	<ol style="list-style-type: none"> 1. Set CREC data configuration 2. Pump recycle is carried out (see above) 3. DPU confirms instrument status from instrument housekeeping 	CREC
COOL	CREC STOP	<ol style="list-style-type: none"> 1. Set REDY mode data configuration 	REDY

Table 4.8: Recycling the cooler

5. OBSERVATORY FUNCTIONS

In this section the OBSERVATORY and INSTRUMENT FUNCTIONS outlined in Section 2 are discussed in more detail, including the scientific reasoning behind the choice of a particular OBSERVATORY FUNCTION. Also given in this section are details of the required INSTRUMENT DATA CONFIGURATIONS and the INSTRUMENT COMMAND SEQUENCES required to build the nominal set of INSTRUMENT FUNCTIONS.

5.1 Observatory Functions for the Photometer

Any astronomical observations with the photometer can be implemented with one of three types of OBSERVATION. We therefore envisage three major AOTs being defined to assist astronomers in preparing the input necessary to specify the OBSERVATIONS.

The OBSERVATORY FUNCTIONS for the photometer are listed below

OBSERVATION	OBSERVATORY FUNCTION	Name	Comments
Point source photometry	POF1	Chop without jiggling	Accurate pointing and source position
	POF2	Seven-point jiggle map	Inaccurate pointing or source position
Jiggle mapping	POF3	n-point jiggle map	Field mapping
	POF4	Raster map	Extended field mapping
Scan mapping	POF5	Scan map without chopping	Large-area mapping
	POF6	Scan map with chopping	Large area mapping (with 1/f noise)
Peak-up	POF7	Photometer peak-up (TBD)	Determination of pointing offsets
Calibrate	POF8	Photometer calibrate	Responsivity tracking
Engineering modes	POF9	Special engineering/ commissioning modes (TBD)	TBD

Table 5.1: Photometer Observatory Functions

5.1.1 POF1: Chop Without Jiggling

Purpose:

This is similar to what is often done on ground-based submillimetre telescopes. It is designed to make observations of a point or compact source of accurately known position, using one detector of the feedhorn array. In the case of SPIRE, chopping is done between two sets of three detectors that are co-aligned on the sky so that simultaneous observations are done in the three bands with maximum efficiency.

Description:

1. This Observatory Function is composed of the following instrument and Spacecraft Functions:

Instrument Function: Photometer Chop

Spacecraft Function: Nod

2. The telescope is pointed at the commanded position, which is aligned with the centre of the arrays.
3. In nominal operation, the BSM chops symmetrically at f_{chop} about this position in the Y-direction, moving the source alternately onto the two sets of three co-aligned detectors near the centre of the arrays- see Figure 5.1-1. Chopping in a direction not parallel to the Y-axis will be possible, but not normally used.
4. If required, the telescope can also nod at frequency f_{nod} , where $f_{\text{chop}} \gg f_{\text{nod}}$. There is no requirement that f_{nod} be a precise multiple of f_{chop} . A value of > 1 minute and < 4 minutes per nod cycle is appropriate, otherwise the telescope settling time overhead (10-18 seconds) will become prohibitive or the nod time will become excessive. At present, we assume a nominal

value of 3 minutes.

- The source signal is computed as the difference between the signals recorded at the two nod positions, as shown in Fig 5.1-1. The purpose of nodding is to remove signal offsets due to asymmetrical background power in the two beams and to cancel the effects of any telescope temperature drifts. The nodding capabilities of the FIRST spacecraft are summarised in the *FIRST Scientific Pointing Modes Document*, p.10.

Let

S	= Source signal
O_A	= Offset signal for beam A
O_B	= Offset signal for beam B

Then Signal

$$= (A_1 - B_1) - (A_2 - B_2)$$

$$= [(S + O_A) - O_B] - [O_A - (S + O_B)]$$

$$= 2S$$

Figure 5.1: Telescope nodding to cancel out differences in the background power on the detector in the two chop positions.

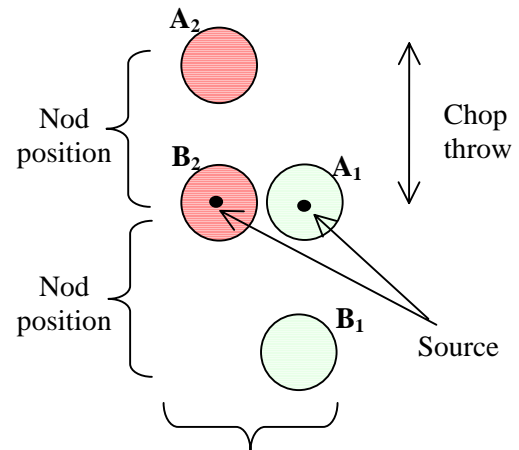

- Chopping between pairs of pixels gives maximum sensitivity because in that case the source is being observed all the time. There is simultaneous overlap at all three wavelengths for 14 sets of detectors, if the wavelengths are in the ratio 1:0.75:0.5. The source is chopped between positions A_1 and B_1 when in nod position 1 and between A_2 and B_2 when in nod position 2. Signals can be determined from pairs (A_1, B_1) and (A_2, B_2) .

Figure 5.2: Sets of detectors (shaded) for which there is simultaneous overlap in all three bands for the feedhorn array option. For chopped observations, one of the sets nearest the centre of the array is used as to define the prime pointing direction.

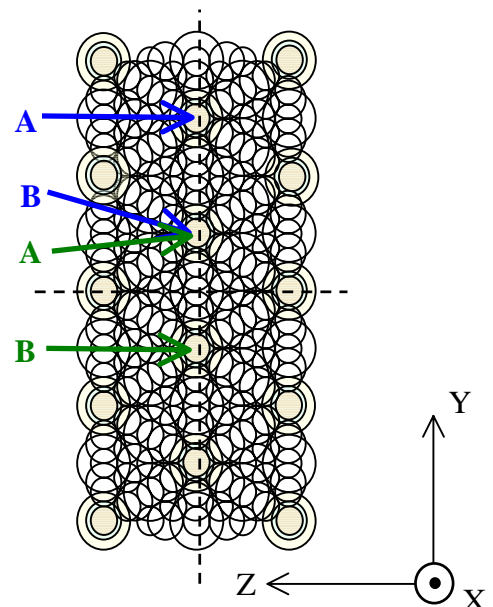

- Chop distance on the array:

d_{chop}	=	$4F\lambda$ at $500 \mu\text{m}$
	=	$(4)(5)(0.5) = 10 \text{ mm}$ at the array focal plane.
- Chop angle on the sky:

θ_{chop}	=	$(10 \text{ mm})(12.6 \text{ "/mm})$
	=	$126 \text{ arcsec. (2.1 arcmin.)}$

Smaller or larger chop amplitudes can be used, but then it will not be possible to have exact overlap between detectors.

8. Chop distance on the array: $d_{\text{chop}} = 4F\lambda$ at $500 \mu\text{m}$
 $= (4)(5)(0.5) = 10 \text{ mm}$ at the array focal plane.

Chop angle on the sky: $\theta_{\text{chop}} = (10 \text{ mm})(12.6 \text{ "/mm})$
 $= 126 \text{ arcsec. (2.1 arcmin.)}$

Smaller or larger chop amplitudes can be used, but then it will not be possible to have exact overlap between detectors.

9. This mode requires pointing accuracy sufficiently good that the loss of signal due to the pointing error is acceptable. The signal loss factors for the photometer beams are shown below.

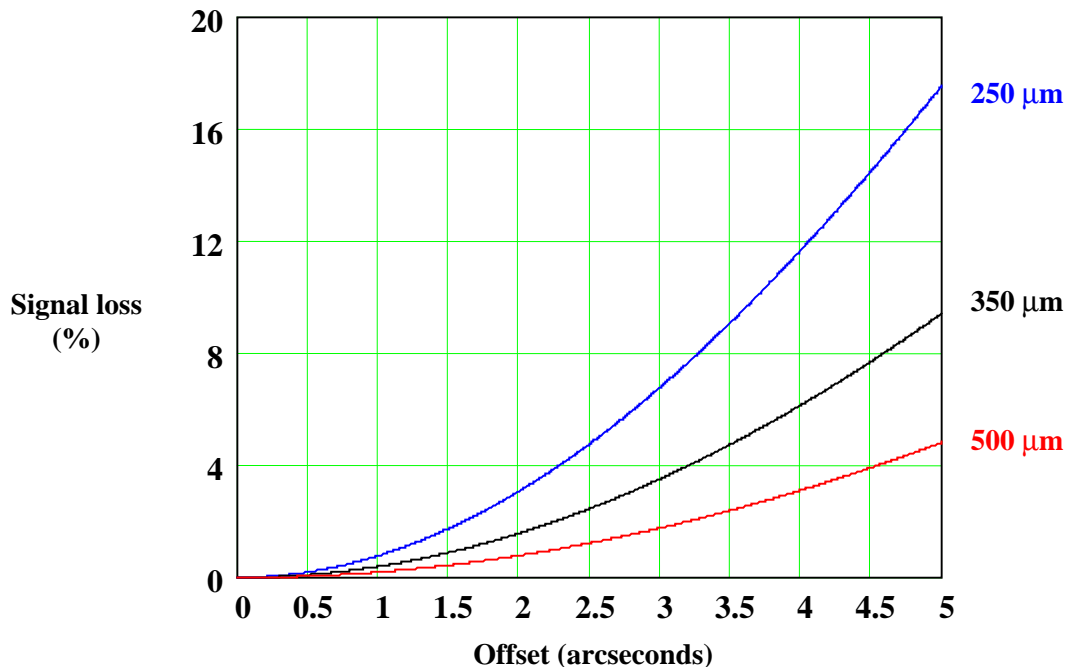

Figure 5.3: Signal loss vs. pointing error for the SPIRE photometer

10. The required APE (3.7") corresponds to 11%, 6%, 3% signal loss at 250, 350, 500 μm respectively. The goal (1.5") corresponds to 2%, 1%, 0.5% signal loss at 250, 350, 500 μm respectively. For most observations, 11% is not acceptable, but 2% is. Therefore, the required APE is not good enough to allow accurate photometry at 250 μm without peaking up, but the goal is sufficient to allow this. In the event that the pointing accuracy is not good enough to allow blind pointing then either:

- (i) this Observatory Function will not be used, or
- (ii) it will be used but only when preceded by a peaking-up routine (POF7).

Instrument and Spacecraft Functions used and their parameters:

Table 5.2 Photometer Observatory Function POF1: Chop Without Jiggling				
Instrument Function: Photometer Chop				
No.	Parameter	Range of values	Nominal value	Comments
1	Chop frequency	0.2 (TBC) - 2 Hz	2 Hz in Y	Max frequency is 1 Hz in the Z direction or any compound Y-Z angle
2	Chop direction	Any direction in the Y-Z plane	Parallel to the Y-axis	Max frequency is 1 Hz in the Z direction or any compound Y-Z angle
3	Chop throw	Any value within the BSM range (± 2 arcmin. in Y; ± 0.25 arcmin in z)	126" (± 63 ") on the sky parallel to Y-axis	
4	Total integration time	Min = 4 hop cycles Max = TBD	None	Only required if not nodding
Spacecraft Function: Nod				
1	Nodding	ON or OFF	ON	Nodding is optional
2	Nod period	Any value within allowed range	3 minutes	The SPMD does not give complete information on the ranges of nod amplitude and frequencies that are possible. A nominal figure of 3 minutes for the total nod cycle time is appropriate for SPIRE.
3	Nod direction	Same as the chop direction	Parallel to the Y-axis	
4	Nod throw	Same as the chop throw	126"	
5	Total number of nod cycles	Min = 1 Max = TBD	None	Specifies total integration time if nodding

5.1.2 POF2: Seven-Point Jiggle Map

Purpose:

This Observatory Function is designed for observation of an isolated compact source where uncertainties in the telescope pointing and/or the source coordinates mean that the accuracy of blind pointing cannot be relied upon. A small map must be made around the nominal pointing position to make sure that the source signal can be correctly estimated. It is effectively a combination of seven separate measurements using POF1.

Description:

1. POF2 is composed of the following instrument and Spacecraft Functions:

Instrument Function: Photometer Chop
 Photometer 7-Point Jiggle

Spacecraft Functions: Nod

2. The BSM is used to do a small map 7-point hexagonal jiggle map with spacing θ arcsec., as shown below. A suitable value for θ is $\sim 6''$: this spacing is 1/3 of the beam at $250 \mu\text{m}$ (so consistent with full sampling), and is almost twice the APE.

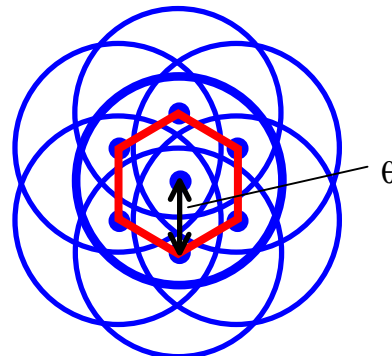

Figure 5.4 : Seven-point hexagonal jiggle pattern. The order in which the seven points are visited is TBD

3. From such a 7-point map, the total flux of the source can be computed (see Griffin, Bock and Gear, *Comparison of sensitivities of 0.5F λ , 1.0F λ and 2.0F λ arrays for the BOL*, 15 Dec. 1997.)
4. The central position is made to coincide with one of sets of three overlapping detectors to allow simultaneous optimised observations in the three bands.
5. The chop throw can be set at any desired value within the available range. A value of $126''$ improves the overall efficiency by allowing the source to be observed all the time in all bands.
6. Nodding is optional.
7. If nodding is ON, then the jiggle and nodding cycles must be coordinated (see below).

Jiggling frequency: At least 2 chop cycles are required at each jiggle position. The minimum dwell time is therefore in the range 1 second (for $f_{\text{chop}} = 2 \text{ Hz}$) and 15 seconds (for $f_{\text{chop}} = 0.2 \text{ Hz}$). As a nominal case, we shall adopt $f_{\text{chop}} = 2 \text{ Hz}$ and 20 chop cycles. We then have 10 seconds per jiggle position and about 70 seconds per jiggle cycle.

Coordination of jiggle and nod cycles: The optimum operational sequence will be:
 N jiggle cycles (7 positions each)

Nod and wait to settle
Next set of N jiggle cycles

SPIRE will be allowed to control the timing of the telescope nodding motions - these will be pre-programmed in the daily up-link of the observing sequences. The nod period should therefore be predetermined to provide an integer number of complete jiggle cycles at each nod position.

On-board processing and data rate: As POF1.

Instrument and Spacecraft Functions used and their parameters:

Table 5.3: Photometer Observatory Function POF2: Seven-point jiggle map				
Instrument Function: Photometer Chop				
No.	Parameter	Range of values	Nominal value	Comments
1	Chop frequency	As for POF 1		
2	Chop direction	As for POF1		
3	Chop throw	As for POF1		
Instrument Function: Photometer Jiggle				
1	Jiggle pattern	7-point (central + hexagon) with angular separation θ	$\theta = 6$ arcsec.	
2	Number of chop cycles/jiggle position	Min = 2 Max = TBD	Such as to give roughly 1 minute per jiggle cycle	
3	Number of jiggle cycles/nod position	N = 1 – TBD	1	
4	Total integration time	Min = 2 jiggle cycles Max = TBD	None	Only required for nodding OFF
Spacecraft Function: Nod				
1	Nodding			
2	Nod period	Determined by the time taken for N jiggle cycles	Set to allow one jiggle cycle per nod position	
3	Nod direction	As for POF1		
4	Nod throw	As for POF1		
5	Total number of nod cycles	As for POF1		

5.1.3 POF3: n-Point Jiggle Map

Purpose: This mode is for mapping objects or regions which are extended with respect to the SPIRE beam but smaller than a few arcminutes in size. Its implementation is very similar to POF2.

Description:

- POF3 is composed of the following instrument and Spacecraft Functions:

Instrument Function:	Photometer Chop Photometer n-Point Jiggle
Spacecraft Functions:	Nod

- The BSM is used to make an n-point jiggle map while chopping with a throw greater than the size of the object to be mapped. The maximum throw is 4 arcminutes (± 2 arcminutes) as illustrated below.

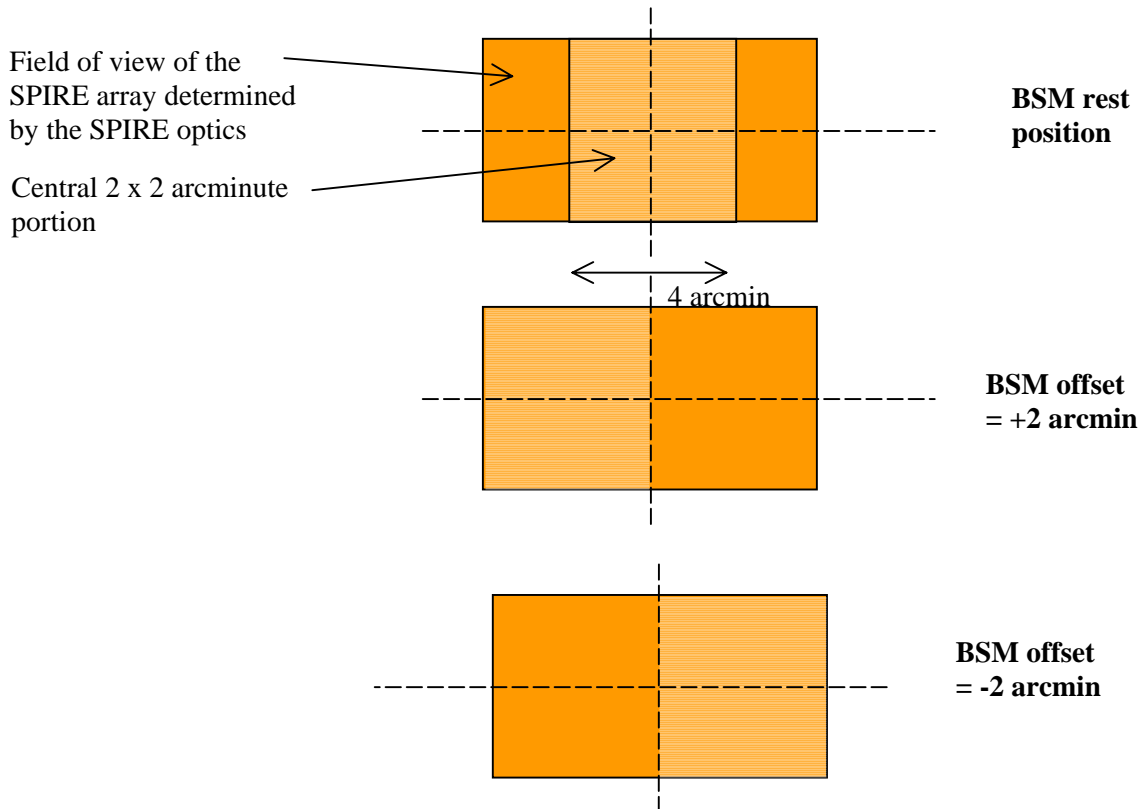

Figure 5.5: Field mapping with maximum chop throw of 4 arcminutes. The detectors in the central square 2 x 2 arcminute portion of a photometer array are deflected by ± 2 arcminutes by the BSM, so that they are alternately chopped from one side of the available field of view to the other.

- For full sampling at all wavelengths, $n = 64$. Considering the simplified case of square-packed horns, the step size must be $0.5\lambda/D = 9''$ at $250 \mu\text{m}$ and the number of steps must accommodate the need to cover the distance between two beams at $500 \mu\text{m}$: $2\lambda/D = 72''$. Eight steps in each orthogonal direction are thus required. The geometry of the jiggle pattern is hexagonal for the

hexagonally packed feedhorns, but the number of steps required is still 64.

4. To allow flexibility in the use of this mode, permitted values of n shall be 16, 32 and 64.
5. The jiggle positions shall be defined by angles $\Delta\theta_Y$ and $\Delta\theta_Z$ in the Y and Z directions (with respect to the BSM rest position).
6. The sequence in which the jiggle positions are visited is TBD.
7. The chop throw is chosen to be greater than the size of the source to be mapped.
8. Nodding is optional.
9. If nodding is ON, then the jiggle and nodding cycles must be coordinated.

Jiggle frequency:

We assume for now that:

- (i) a complete nod cycle must be executed at least every three minutes (TBC);
- (ii) the dead time due to the nodding motions is 18 seconds (as indicated in the *SPMD*);
- (iii) we will want to execute a complete jiggle cycle at each nod position;
- (iv) there should be at least two chop cycles per jiggle position.

This gives a maximum of 72 seconds per jiggle. For $n = 64$, this corresponds to 1.125 seconds maximum per jiggle point - say 1 second to allow some margin. This can be done with 2 chop cycles per jiggle position at the maximum chop frequency of 2 Hz.

Co-ordination of jiggle and nod cycles: As for POF2.

On-board processing and data rate: As for POF1.

Instrument and Spacecraft Functions used and their parameters:

Table 5.4: Photometer Observatory Function POF3: n-Point Jiggle Map				
Instrument Function: Photometer Chop				
No.	Parameter	Range of values	Nominal value	Comments
1	Chop frequency	As for POF1		
2	Chop direction	As for POF1		
3	Chop throw	As for POF1	± 2 arcmin. (chopping the full field)	
Instrument Function: Photometer Jiggle				
1	Jiggle pattern	n-point with positions $(\Delta\theta_Y, \Delta\theta_Z)$ with respect to the pointed position n = 16, 32, 64	n = 64 $(\Delta\theta_Y, \Delta\theta_Z)$ are TBD	
2	Number of chop cycles/jiggle position	Min = 2 Max = TBD		
3	Number of jiggle cycles/nod position	N = 1 (TBC)	1	
4	Total integration time for the map	Min = 2 jiggle cycles Max = TBD	None	Only required for nodding OFF
Spacecraft Function: Nod				
1	Nodding	ON or OFF	ON	
2	Telescope nod period	Min = 3 min Max = TBD	~ 3 min. (TBC)	Determined by the time taken for N jiggle cycles
3	Nod direction	As for POF1		
4	Nod throw	As for POF1		
5	Total number of nod cycles	As for POF1		

5.1.4 POF4: Raster Map

Purpose:

This Observatory Function is for mapping a source larger than the SPIRE field of view or to carry out a survey of a large area of sky. It involves jiggle-mapping observations at a grid of telescope pointings. The telescope raster pointing capabilities are described in the *SPMD* (p. 2).

Description:

1. POF4 is composed of the following instrument and Spacecraft Functions

Instrument Function: Photometer Chop
 Photometer n-Point Jiggle
Spacecraft Functions: Nod (optional)
 Normal Raster Pointing

2. The available field is the central 2 x 2 arcminute portion of the array.
3. The raster is a rectangular grid of separate pointings as shown in Section 2. The sequence at each point in the raster is exactly as in n-Point Jiggle Map (POF3).
4. The astronomer will wish to specify a region to be mapped in RA and Dec. The relationship between the coordinate frames will depend on exactly when the observations are scheduled. The translation of the astronomer's desired map region into a region suitable for mapping in spacecraft co-ordinates poses a problem for the efficient implementation of this mode. For SPIRE, we require the raster axes to be defined in terms of spacecraft (array) coordinates. The conversion between spacecraft and celestial coordinates depends on when the observations are scheduled - this issue must be addressed in the mission planning.
5. Other issues to be addressed:
For long rasters, it may be necessary to interleave calibration observations.

On-board processing and data rate: As for POF1.

Instrument and Spacecraft Functions used and their parameters:

Table 5.5: Photometer Observatory Function POF4: Raster Mapping				
Instrument Function: Photometer Chop				
No.	Parameter	Range of values	Nominal value	Comments
1	Chop frequency		As for POF3	
2	Chop direction		As for POF3	
3	Chop throw		As for POF3	
Instrument Function: Photometer Jiggle				
4	Jiggle pattern		As for POF3	
5	Number of chop cycles/jiggle position		As for POF3	
6	Number of jiggle cycles/nod position		As for POF3	
7	Total integration time per raster point		As for POF3 except time per raster point	
Spacecraft Function: Nod				
1	Nodding		As for POF3	
2	Telescope nod period		As for POF3	
3	Nod direction		As for POF3	
4	Nod throw		As for POF3	
5	Total number of nod cycles per raster point		As for POF3 except no. of cycles per raster point	
Spacecraft Function: Normal Raster Pointing				
1	Number of pointings per line (M)	Min = 2 Max = 32		Depends on size of region to be mapped
2	Number of lines (N)	Min = 1 Max = 32		Depends on size of region to be mapped
3	Angular distance between successive steps (d_1)	Min = 2 arcsec. Max = 4 arcmin.	Probably in the range 1 - 4 arcmin.	Some overlap between successive sub-maps is desirable
4	Angular distance between successive lines (d_2)	Min = 0 or 2 arcsec. Max = 4 arcmin.	Probably in the range 1 - 4 arcmin.	Some overlap between successive sub-maps is essential

5.1.5 POF5: Scan Map Without Chopping

Purpose:

This Observatory Function is for mapping a large region of sky by scanning the telescope to provide spatial modulation of the signal. This is the preferred observing mode for deep extragalactic surveys. Chopping is not done to avoid increasing confusion noise. The telescope scanning capabilities are described in the *SPMD* (p. 4).

Description:

POF5 is composed of the following instrument and Spacecraft Functions

Instrument Function:	No-Chop
Spacecraft Functions:	Normal Line Scanning

1. The line scans are carried out along parallel lines as described in Section 2.
2. Chopping and nodding are not performed.
3. The telescope is scanned continuously across the sky. The spacecraft can scan at rates between 0.1 arcsec./sec and 1 arcmin./sec. (*SPMD*, p.8).
4. The scan direction must be in spacecraft coordinates.
5. For optimum sky sampling, the angle of the scan must have a particular value of 14.5° (TBC) with respect to one of the array axes (Y or Z), as shown in Fig. 5.6.

An alternative arrangement of the detectors in the focal plane could be to orient the lines of detectors at this angle and then to scan exactly along the Z or Y directions.)

6. The length of each line should be such that the turn-around time of the telescope (here assumed to be 10 seconds) does not constitute a large overhead. Each line should therefore take at least 60 seconds.

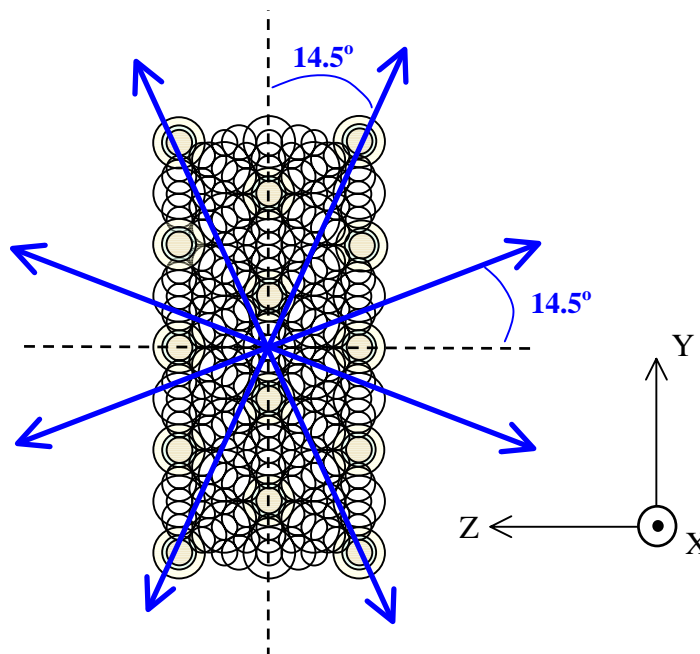

Figure 5.6: Allowed scan directions.

Detector sampling:

The demodulated detector signals are to be sampled at 25 Hz (TBC) with 16-bit resolution.

On-board processing and data rate: As for POF 1. The timing of the samples does not need to be synchronised to the telescope movements, but must be available on the ground in order to reconstruct the pointing and generate the maps. This will allow a specific telescope position to be assigned to every detector sample.

Instrument and Spacecraft Functions used and their parameters:

Table 5.6: Photometer Observatory Function POF5: Scan Map Without Chopping				
Instrument Function: Photometer Non-Chop				
No.	Parameter	Range of values	Nominal value	Comments
1	Chopping	OFF	OFF	
Spacecraft Function: Normal Line Scanning				
1	Scan direction	One of the 8 directions indicated in Fig. TBD above.	TBD	
2	Scan rate	Min = 0.1 arcsec./sec. Max = 60"/sec.	TBD. Possibly ~ 20"/sec.	Depends on 1/f noise of the whole system
3	Angular length of each line scan (D_1)	> (60 sec.)*(scan rate) Min = 10 arcmin. Max = 110°		Depends on size of area to be mapped. Unlikely to be > a few degrees.
4	Number of lines (N)	Min = 1 Max = 32		Depends on size of region to be mapped
5	Angular distance between successive steps (d_2)	Min = 2 arcsec. or 0 Max. = 4 arcmin.	Probably in the range 1 - 4 arcmin.	Some overlap between successive sub-maps is essential

5.1.6 POF6: Scan Map With Chopping

Purpose:

This Observatory Function allows for mapping a large region of sky by scanning the telescope with the chopper operating. This mode could be useful in the event of high 1/f noise degrading the S/N for non-chopped scan observations.

Description:

1. POF6 is composed of the following instrument and Spacecraft Functions

Instrument Function: Photometer Chop
 Spacecraft Functions: Normal Line Scanning

2. The line scans are carried out as for POF5.
3. Nodding is not performed.
4. Chopping is performed, in the direction parallel to or perpendicular to the direction of the telescope scan.
5. The telescope is scanned continuously across the sky at a rate that provides a beam crossing time much longer than a chop cycle.
6. It is required that the signal from an individual chop cycle be ascribed to an interval of less than 1 arcsec. on the sky (roughly 1/20th of a beam at 250 μ m). The maximum allowed scan rate in arcsec./sec. is then the same as f_{chop} in Hz: e.g., for $f_{\text{chop}} = 1$ Hz, the maximum scan rate is 1"/sec.

Detector sampling, on-board processing and data rate: As for POF5.

Instrument and Spacecraft Functions used and their parameters:

Table 5.7: Photometer Observatory Function POF6: Scan Map With Chopping				
Instrument Function: Photometer Chop				
No.	Parameter	Range of values	Nominal value	Comments
1	Chop frequency	0.2 (TBC) – 1 Hz	1 Hz	
2	Chop direction	Parallel to or perpendicular to scan direction	TBD	
3	Chop throw	Any value within the BSM range (± 2 arcmin. in Y; ± 0.25 arcmin in z)	TBD	
Spacecraft Function: Normal Line Scanning				
1	Scan direction		As for POF5	
2	Scan rate		As for POF5	
3	Angular length of each line scan (D_1)		As for POF5	
4	Number of lines (N)		As for POF5	
5	Angular distance between successive steps (d_2)		As for POF5	

5.1.7 POF7: Photometer Peak-Up

Purpose:

This Observatory Function is designed to allow SPIRE to peak up the pointing on a sufficiently strong point-like source. As far as the observations are concerned, it is the same as POF3 (7-Point Jiggle Map), and this POF may therefore be deleted for simplicity. For the moment, it is included to account for the possibility that peaking up involving autonomous computation of the required pointing corrections by the SPIRE DPU may be needed in some cases.

Description:

1. POF6 is composed of the following instrument and Spacecraft Functions

Instrument Function:	Photometer-Chop
Spacecraft Functions:	Nod

2. SPIRE does a standard seven-point jiggle observation (POF3).
3. The offset of the source with respect to the commanded pointing is computed by the DPU using the recorded data.
4. The calculated pointing offsets ($\Delta\theta_Y$ and $\Delta\theta_Z$) are
 - (a) implemented by the BSM (baseline) or
 - (b) transmitted to the spacecraft AOCS.
5. If (b), the AOCS checks that the required telescope movement is within the acceptable limits and executes it.
6. (a) The AOCS transmits a message to SPIRE confirming that the pointing correction has been implemented,

OR

- (b) SPIRE waits for a standard period of time to elapse before flagging the data as valid
7. The need for this function is TBD. It is not needed for very bright objects (carrying out a small map is quick compared to overheads from slewing etc.). Nor is it practical for very faint objects (poor S/N of the 7-point data would lead to inaccurate offset calculation). It is therefore only likely to be useful for a particular band of source strengths (exact limits TBD).

An alternative approach might be to establish an accurate pointing model covering the available sky window by regular observation of a selection of bright point sources, calculating the pointing offsets on the ground, and uplinking the derived pointing model parameters to the spacecraft. This would depend on the availability of good pointing sources distributed over the viewable sky, and on the pointing characteristics being highly repeatable and dependent only on the pointing direction (not on the pointing history).

5.1.8 POF8: Photometer Calibrate

It is envisaged that the photometer calibrator will be operated at intervals of an hour or more. Its function is to present a repeatable signal to the detectors. This will allow characterisation of :

- (i) any responsivity, system gain or time constant drifts;
- (ii) any variation of the detectors' responsivity with radiant loading (e.g., non-linear response when viewing very bright sources).

In operation, it will be powered by a pre-selected waveform, and the corresponding signals will be recorded. A typical duration of the whole sequence will be ~ 10 sec. The BSM must be fixed at its rest position, and the telescope pointing must also be fixed so that the only signal modulation is from the calibrator.

To allow calibration to be performed flexibly, it may be advantageous to incorporate this function within some of the other POFS (e.g., to enable calibrator flashes to be interspersed between the rows of line scanning observations).

Table 5.8: Photometer Observatory Function POF8: Photometer Calibrate				
Instrument Function: Photometer Calibrate				
No.	Parameter	Range of values	Nominal value	Comments
1	Chopping	OFF	N/A	
2	PhotCal	ON	TBD	A preset sequence of drive currents
Spacecraft Function: Pointed				
1	Pointed	(θ_{YP} , θ_{ZP})	N/A	The spacecraft is not required to do anything else

5.2 Observatory Functions for Spectrometer

Any astronomical observations with the spectrometer can be implemented with only one type of OBSERVATION. We therefore envisage only one AOT being defined to assist astronomers in preparing the input necessary to specify the OBSERVATION.

Two Spectrometer Observatory Functions (SOFs) are defined for low/medium resolution and high resolution to take account of any differences in the on-board processing that might be required.

5.2.1 SOF1: Point Source Spectrum

Purpose

To take a spectrum of a point source that is well centred on the central detectors of the FTS arrays. The spectrum to be taken has a resolution of no more than $R = 0.4 \text{ cm}^{-1}$ implying a mirror mechanism movement of no more than $\pm 0.32 \text{ cm}$. Double sided interferograms are taken.

Description

This is an example Observatory Function for a resolution of 0.4 cm^{-1} . The distance the FTS mechanism has to scan will be set by the required resolution.

1. This Observatory Function is composed of the following instrument and Spacecraft Functions:

Instrument Function: Spectrometer Scan
Spacecraft Function: Pointed

2. If not already powered on, the FTS calibrator is switched on to a pre-defined level and allowed to stabilise for TBD minutes.
3. The telescope is pointed at a known position, with the source lying on the central detector of the short-wavelength array - pointing offset (θ_{YS} , θ_{ZS}).
4. The FTS mirror mechanism is scanned from -0.32 cm to $+0.32 \text{ cm}$ with the velocity controlled by the drive electronics. The scan will take about 7 seconds to complete. The detectors and the position sensor are read out asynchronously whilst the mechanism is moving – i.e. the default is to time-sample the FTS mechanism position.
5. Each interferogram for each detector is stored in the DPU memory and is a maximum of about 110 kbytes for all 56 detectors if sampled at 12 bits with no data compression. The data rate into the DPU is $\sim 16 \text{ kbytes/sec}$.

Each detector produces a raw interferogram of about 2 kbytes – this could just fit into a single telemetry packet if they were allowed to be this big. Also the proposed lossless compression may not work as well for these scan ranges as one could never be certain about where one should start throwing away the MSB. This is why this mode is differentiated from the high resolution mode described below.

6. The scan is repeated until the desired integration time has been reached.

Instrument and Spacecraft Functions used and their parameters:

Table 5.9: Spectrometer Observatory Function SOF1: Low/Medium Resolution Point Source				
Instrument Function: Spectrometer Scan				
No.	Parameter	Range of values	Nominal value	Comments
1	Mirror Velocity	0.02-0.1 cm s ⁻¹ (depends on stability of the instrument and the response of the detectors)	TBD	
2	Scan Range	Selectable between ±0.07 cm (R = 2 cm ⁻¹) and -0.35 cm to +3.2 cm (R=0.04 cm ⁻¹) with 8 (TBC) choices	N/A	These scan ranges allow some extra range for mirror turn-around.
3	Total number of scans	Minimum of 3 for comparison and deglitching	> 1 min	The minimum integration time is 5 seconds for the minimum resolution. This would be inefficient given telescope motion overheads
Spacecraft Function: Pointed				
1	Pointed	(θ_{YS} , θ_{ZS})	N/A	The spacecraft is not required to do anything else

5.2.2 SOF2: Fully Sampled Spectral Map within FOV

Purpose

To take a spectrum of a region of sky or an extended source that is within the FOV of the spectrometer – i.e. less than 2.6 arcmin circular. This is achieved by using the beam steering mirror to perform a low-frequency jiggle and taking one or more interferograms at each point of the jiggle pattern. The spectrum to be taken at each point has a resolution of no more than R=0.4 cm⁻¹ implying a mirror mechanism movement of no more than ±0.32 cm.

Description

This is an example Observatory Function for a resolution of 0.4 cm⁻¹. The distance the FTS mechanism has to scan will be set by the required resolution.

1-4: As for SOF1

- The BSM is used to make an n-point jiggle map as in POF3. The mirror is held at each position while several FTS scans are carried out.
- For full sampling at all wavelengths, n = 25. Considering the simplified case of square-packed horns, the step size must be $0.5\lambda/D = 9''$ at 250 μm and the number of steps must accommodate the need to cover the distance between two beams at 350 μm: $2\lambda/D = 45''$. Five steps in each orthogonal direction are thus required. The geometry of the jiggle pattern is hexagonal for the

hexagonally packed feedhorns, but the number of steps required is still 25.

7. At each jiggle position the FTS mirror mechanism is scanned. The number of interferograms required per position is TBD (a minimum of three would seem sensible, and could be built up either by repeating the jiggle three times or doing three scans at each position of a single jiggle). With three scans per position, it will take at least 525 seconds to take a fully sampled $R=0.4 \text{ cm}^{-1}$ 2.6 arcmin circular map – with overheads this will be around ten minutes.
8. Each interferogram for each detector is stored in the DPU memory and is a maximum of about 110 kbytes for all 56 detectors if sampled at 12 bits with no data compression. The rate into the DPU is ~16 kbytes/sec. The assumption is that there will be no co-addition of the interferograms for each jiggle position.
9. The jiggle/scan is repeated until the desired integration time has been reached for the whole map.

Instrument and Spacecraft Functions used and their parameters:

Table 5.10: Spectrometer Observatory Function SOF3: Fully Sampled Spectral Map within FOV - Low/Medium Resolution				
Instrument Function: Spectrometer Scan				
No.	Parameter	Range of values	Nominal value	Comments
1	Prime detector		As for SOF1	
2	Mirror Velocity		As for SOF1	
3	Scan Range		As for SOF1	
Instrument Function: Spectrometer Jiggle				
1	Jiggle pattern	n-point with positions $(\Delta\theta_Y, \Delta\theta_Z)$ with respect to the pointed position $n = 25, 64$ $\theta = 2-9''$	$n = 25$ $(\Delta\theta_Y, \Delta\theta_Z)$ are TBD	The number of points could just be fixed as one number
2	Number of FTS scans per jiggle position	Min = 1 Max = TBD	TBD	We need to see whether it is better to go for fully sampled images as fast as possible or to have many FTS scans per jiggle position - it depends on the drifts and noise
3	Total number of jiggles	Min = 1 Max = TBD	None	
Spacecraft Function: Pointed				
1	Pointed		As for SOF1	

6. DEGRADED OPERATIONS

A criticality analysis has been carried out at the instrument level to assess what extra operating modes may be required in the event of a failure or partial failure of one of the SPIRE sub-systems (see SPIRE-RAL-NOT-000319 Iss. 0.3). The need for the following degraded operating modes has been identified:

Automatic Cooler Recycling

At present the baseline is that cooler recycling will be undertaken during one of the ground contact times thus making use of the times when observing is restricted or not possible. If the cooler does not have the ability to operate for the required length of time due to increased thermal load or some other reason, it may become necessary to undertake cooler recycling more frequently than this. However if the cooler needs more frequent recycling it may be that the most efficient way of operating is to have the recycle done autonomously under control of the DPU alone. This mode of operation must be planned for and thoroughly tested before launch.

Slow Chop Mode

If the BSM suffers a failure that prevents it from chopping at the default frequency due to sticking or excessive dissipation, it may be that it may have to be chopped very much more slowly. This implies that the control circuitry and algorithms must be capable of driving the BSM at any frequency from DC up to the maximum allowable by the design. A range of chop frequencies must be identified and the instrument response at these frequencies characterised before launch.

BSM Open Loop

In the event of a failure of the position sensor on the BSM chop axis, it must still be possible to operate the BSM by commanding the current to the actuators directly. This mode of operation may lead to a loss of efficiency as the chopping mirror will not be under control and may take some time to become stable after movement. The behaviour of the BSM under open loop control must be characterised and suitable current demand algorithms devised to allow at least the chopped mode to be carried out in the event of loss of the chop axis position sensor.

Single Axis BSM Operation

It may be that one axis of the BSM stops working during the mission. In this case it must be possible to use the other axis on its own to chop or, if the chop axis is lost, at least to pixel-swap on one of the detector arrays. It may be that there is some mechanical crosstalk between the axes and demand will be required on both axes during nominal operation to achieve accurate positioning. If this is the case the operation of each axis in the absence of the other must be possible and this mode of operation fully characterised before launch.

Slow scanning of the FTS mirrors

If there is, for any reason, a problem with the amount of data that can be telemetered to the ground, one way of reducing the data rate from the spectrometer is to slow down the scan rate for the FTS mirrors. Also, if there is any problem with the mirror drive, sticking or high dissipation, it may be that this also could be alleviated by slowing down the scan rate. A series of FTS mirror scan speeds must be allowed for in the design and the instrument response at each speed characterised before launch.

Step and look operation

In the event of a total inability to scan the FTS mirrors – or in the event of excessive velocity jitter or a serious loss of ability to telemeter data – it may be that the FTS mirrors could be operated stepwise. In order to modulate the signal at each step the BSM will have to be used to chop the source on and off the

central pixel of the arrays. With the correct pixel arrangement this may not lead to a large loss in efficiency. The FTS mirror mechanism must be capable of operating stepwise and in conjunction with the BSM. This mode of operation must be fully characterised before launch.

Open loop operation of the FTS mechanism

In the event of loss of the FTS mechanism position sensor the mirrors can still be driven by use of direct command of the current to the actuator. This mode of operation will lead to loss of fidelity in the reconstructed spectrum as the position of the mirrors will need to be inferred rather than directly measured. However some information should be recoverable. The behaviour of the FTS mechanism in open loop control must be characterised and suitable current demand algorithms devised to allow full range scanning and step and look operation.

Selection of pixels for telemetry

If there is, for any reason, a problem with the amount of data that can be telemetered to the ground, another way of reducing the data rate is to telemeter the data from a limited subset of the detectors in either the photometer or the detector. The detectors that will be telemetered under these circumstances must be identified and the appropriate selection procedures coded into the data reading hardware and/or on board software. These low data rate modes must be fully implemented and tested before launch.

Spectrometer Operation without calibrator

In the event of the loss of the spectrometer calibrator the dynamic range in the signal will be very much higher and more bits may be required to encode the data. This may violate the constraint on the amount of data that can be telemetered. A well developed scenario must be developed that allows as much data as possible to be sent to the ground in spectrometer mode. This may involve lossless data compression; selection of only a few detectors and/or slowing down the spectrometer mirrors. This mode of operation must be fully implemented and tested before launch.