

Herschel/Planck

INSTRUMENT INTERFACE DOCUMENT PART B

INSTRUMENT "SPIRE"

	Name	Signature
Prepared/ Compiled by:	ALCATEL Herschel/Planck Project team	
Approved by:	M. Griffin	
	Principal Investigator	
	University of Wales, Cardiff.	
Approved by:	Th. Passvogel Project Manager ESA/ESTEC/SCI /PT	

0. TABLE OF CONTENTS

DISTRIBUTION LIST..... 0-7

DOCUMENT CHANGE RECORD 0-8

1. INTRODUCTION 1-1

2. APPLICABLE/REFERENCE DOCUMENTS 2-1

2.1 APPLICABLE DOCUMENTS.....2-1

2.2 REFERENCE DOCUMENTS.....2-1

2.3 LIST OF ACRONYMS.....2-2

3. KEY PERSONNEL AND RESPONSIBILITIES 3-1

3.1 KEY PERSONNEL3-1

3.1.1 *Principal Investigator*3-1

3.1.2 *Co-Principal Investigator*.....3-1

3.1.3 *Instrument Manager*3-1

3.2 RESPONSIBILITIES3-2

4. INSTRUMENT DESCRIPTION 4-1

4.1 INTRODUCTION4-1

4.2 SCIENTIFIC RATIONALE.....4-1

4.3 INSTRUMENT OVERVIEW4-2

4.4 HARDWARE DESCRIPTION.....4-3

4.5 SOFTWARE DESCRIPTION4-4

4.6 OPERATING MODES4-4

4.6.1 *OFF Mode*4-4

4.6.2 *Initialise (INIT) Mode*4-4

4.6.3 *ON Mode*4-5

4.6.4 *Ready (REDY) Mode*4-5

4.6.5 *Standby (STBY) Mode*4-5

4.6.6 *Observe Mode (OBSV) Mode*.....4-5

4.6.7 *Cooler Recycle (CREC) Mode*4-5

4.6.8 *SAFE Mode*4-5

4.7 OBSERVING MODES4-5

4.7.1 *Photometer Observing Modes*.....4-6

4.7.1.1 *Observation: Point Source Photometry*.....4-6

4.7.1.2 *Observation: Jiggle Map*4-6

4.7.1.3 *Observation: Scan Map*.....4-6

4.7.1.4 *Others*.....4-6

4.7.2 *Spectrometer Observing Modes*4-7

4.7.3 *Other Modes*.....4-7

4.7.3.1 *Photometer Serendipity*.....4-7

4.7.3.2 *Photometer Parallel*4-7

4.7.4 *Real-Time Commanding*.....4-7

4.7.5 *Commissioning/calibration Mode*4-8

4.7.6 *FPU operations at Ambient Temperature*4-8

4.7.7	FPU Orientation	4-8
4.8	INSTRUMENT REQUIREMENTS AND PERFORMANCE SPECIFICATION	4-8
4.8.1	Scientific Requirements	4-8
4.8.2	Instrument Performance Estimates	4-11
4.8.2.1	Assumptions	4-11
5.	INTERFACE WITH SATELLITE	5-1
5.1	IDENTIFICATION AND LABELLING	5-1
5.2	INTERFACE LOCATIONS	5-2
5.2.1	MECHANICAL COORDINATE SYSTEM	5-2
5.3	LOCATION AND ALIGNMENT	5-4
5.3.1	Instrument Location	5-5
5.3.1.1	Location of units on the SVM	5-5
5.3.2	Instrument Alignment on the HOB	5-5
5.4	EXTERNAL CONFIGURATION DRAWINGS	5-6
5.4.1	HSFPU	5-6
5.4.2	HSJFS	5-7
5.4.3	HSJFP	5-8
5.4.4	SVM Mounted Units	5-9
5.4.4.1	HSDPU	5-9
5.4.4.2	HSDCU	5-10
5.4.4.3	HSFCU	5-11
5.5	SIZES AND MASS PROPERTIES	5-12
5.6	MECHANICAL INTERFACES	5-13
5.6.1	Inside cryostat	5-13
5.6.1.1	Microvibrations	5-13
5.6.1.2	Thermal Straps	5-13
5.6.2	Outside Cryostat	5-15
5.6.3	On SVM	5-16
5.6.4	On Planck Payload Module	5-16
5.6.5	Cooler valves and piping	5-16
5.7	THERMAL INTERFACES	5-17
5.7.1	Inside the cryostat	5-18
5.7.1.1	Description of the thermal interfaces	5-18
5.7.1.2	Description of Operation and Interfaces for the 3He Cooler	5-18
5.7.1.3	Thermal requirements	5-18
5.7.1.4	Worst case temperatures	5-21
5.7.2	Outside the Cryostat	5-21
5.7.3	On the SVM	5-21
5.7.4	On the Planck Payload Module	5-21
5.7.5	Temperature channels	5-21
5.7.5.1	Instrument Temperature Sensors	5-21
5.7.5.2	Shutter Temperature Sensors	5-22
5.7.5.3	Satellite Temperature sensors	5-23
5.8	OPTICAL INTERFACES	5-24
5.8.1	Straylight	5-24
5.9	POWER	5-25
5.9.1	Power inside the cryostat	5-25
5.9.2	Power outside the Cryostat	5-25
5.9.3	Power on the SVM	5-25
5.9.4	Power on Planck Payload Module	5-26

5.9.5	Power versus Instrument Operating Modes	5-26
5.9.6	Supply Voltages.....	5-26
5.9.6.1	Load on main-bus.....	5-26
5.9.6.2	Power Nominal Turn-on.....	5-27
5.9.6.3	Interface circuits.....	5-28
5.9.6.4	LCL fault conditions.....	5-28
5.9.6.4.1	HSDPU Power Input Circuit Configuration.....	5-29
5.9.6.4.2	HSFCU Power Input Circuit Configuration.....	5-29
5.9.7	Keep Alive Line (KAL).....	5-29
5.10	CONNECTORS, HARNESS, GROUNDING, BONDING	5-30
5.10.1	Harness and Connectors.....	5-30
5.10.2	Grounding	5-32
5.10.3	Bonding	5-34
5.10.4	Electrical Signal Interfaces	5-34
5.10.4.1	1553 Data Buses	5-34
5.10.4.2	Master Clock.....	5-35
5.10.4.3	Launch Latch confirmation.....	5-36
5.11	DATA HANDLING.....	5-37
5.11.1	Telemetry.....	5-37
5.11.1.1	Telemetry rate.....	5-37
5.11.1.2	Data-bus rate.....	5-37
5.11.1.3	Data Packets.....	5-37
5.11.2	S/C housekeeping	5-38
5.11.3	Timing and synchronisation signals.....	5-38
5.11.4	Telecommand.....	5-40
5.12	ATTITUDE AND ORBIT CONTROL/POINTING.....	5-41
5.12.1	Attitude and orbit control.....	5-41
5.12.2	Pointing	5-41
5.12.3	On-Target Flag (OTF).....	5-41
5.13	ON-BOARD HARDWARE/SOFTWARE AND AUTONOMY FUNCTIONS.....	5-42
5.13.1	On-board hardware	5-42
5.13.2	On-board software.....	5-42
5.13.3	Autonomy functions.....	5-42
5.13.4	Instrument Autonomy Housekeeping Packet Definition	5-42
5.13.5	Instrument Event Packet Definition.....	5-42
5.14	EMC.....	5-43
5.14.1	Conducted Emission/Susceptibility.....	5-43
5.14.2	Radiated Emission/Susceptibility	5-43
5.14.3	Frequency Plan.....	5-43
5.15	TRANSPORT AND HANDLING PROVISIONS.....	5-44
5.15.1	Focal Plane Unit.....	5-44
5.15.1.1	Transport Container	5-44
5.15.1.2	Cooling and Pumping restrictions.....	5-44
5.15.1.3	Mechanism positions.....	5-44
5.15.1.4	Unpacking Procedure.....	5-44
5.15.2	JFET/Filter Boxes	5-44
5.15.2.1	Transport Container	5-44
5.15.2.2	Unpacking Procedure.....	5-44
5.15.3	Electronics Units.....	5-45
5.15.3.1	Transport Container	5-45
5.15.3.2	Unpacking Procedure.....	5-45
5.16	DELIVERABLE ITEMS.....	5-46

5.16.1	Instrument Models	5-46
5.16.2	Electrical Ground Support Equipment (EGSE)	5-46
5.16.3	Mechanical Ground Support Equipment (MGSE).....	5-47
5.16.4	Optical Ground Support Equipment (OGSE).....	5-47
5.16.5	System Test Software	5-47
5.16.6	Hardware for the Observatory Ground Segment.....	5-47
5.16.7	Software for the Observatory Ground Segment.....	5-47
5.16.8	Instrument Software Simulator.....	5-47
5.16.9	Test Reference Data	5-48
5.16.10	Instrument Characterisation Data	5-48
5.16.11	Technical Documentation	5-48
6.	GROUND SUPPORT EQUIPMENT.....	6-1
6.1	MECHANICAL GROUND SUPPORT EQUIPMENT	6-1
6.2	ELECTRICAL GROUND SUPPORT EQUIPMENT.....	6-1
6.3	COMMONALITY.....	6-2
6.3.1	EGSE	6-2
6.3.2	Instrument Control and Data Handling.....	6-2
6.3.3	Other areas	6-3
7.	INTEGRATION, TESTING AND OPERATIONS.....	7-1
7.1	INTEGRATION	7-1
7.1.1	HPLM Integration	7-1
7.1.2	PPLM Integration.....	7-1
7.1.3	SVM Integration	7-1
7.1.4	Herschel/Planck Integration.....	7-1
7.2	TESTING	7-2
7.2.1	CQM Testing.....	7-2
7.2.2	PFM Testing	7-5
7.2.3	Thermal on ground Test.....	7-5
7.3	OPERATIONS	7-6
7.4	COMMONALITY	7-6
8.	PRODUCT ASSURANCE	8-1
9.	DEVELOPMENT AND VERIFICATION.....	9-1
9.1	GENERAL.....	9-1
9.2	MODEL PHILOSOPHY	9-1
9.3	MECHANICAL VERIFICATION	9-1
9.4	THERMAL VERIFICATION	9-2
9.5	VERIFICATION OF SCIENTIFIC PERFORMANCE.....	9-2
9.6	ELECTRICAL TESTING	9-2
9.7	EMC TESTING	9-2
10.	MANAGEMENT, PROGRAMME, SCHEDULE.....	10-1

Annex 1: SPIRE ICD/drawings

Annex 2: SPIRE Reduced TMM**Annex 3: Summary of SPIRE cryoharness wiring functions****Annex 4: Description of the Operation of the 3He Sorption Cooler****Annex 5: SPIRE HDD 1.1 Deltas**

DISTRIBUTION LIST

Distribution in electronic format (Adobe PDF)

Qty	Organisation	Institute
1	Herschel/Planck Project Team	ESA
1	Prime Contractor	Alcatel
1	Herschel SPIRE	Univ.Cardiff/RAL
1	ESA Project Scientist	ESTEC

DOCUMENT CHANGE RECORD

Issue-Rev	Date	Version	Pages affected
1-0	01/09/2000	Initial Issue for ITT	New Document
2-0	31/07/2001	Issue for SRR	Complete Revision: Renaming of HERSCHEL by Herschel. Changes made by change bars (including editorial changes).
2-1	13/02/2001	Unpublished version	According to SCI/PT/MM-11440 And DCN .. Includes HP-SP-RAL-ECR-005, 06, 07, 12, 14. ECR 9 and 10 not agreed.
2.2	01/06/2002	PDR version	According to agreed changes published in Minutes of convergence meeting HP-ASPI-MN-1346
3.0	23/09/2003	Not signed issue	According to changes by SPIRE CR & all comments & changes as here under (*), and minutes of IF& IIDB Meetings: H-P-ASP-MN-3513 and H-P-ASP-MN-3668
3.1	02/12/2003	Not signed issue	According to comments & changes by H-P-ASP-MN-3923, H-P-ASP-MN-3961 and as here under (**)
3.11	07/01/2004	New Issue for ESA CCB - Not signed issue	According ASP CCB #41 6 Pages: as here under (***)
3.2	01/03/2004	New Issue for PLM CDR version	According ESA CCB SCI-PT-MM-024070, 13 Pages as here under (****)

(*) Issue 3.0 changes versus issue 2.2:

This Issue 3.0 of SPIRE IIDB takes into account or includes (or not) the following SPIRE CR and/or the ASED/ESA/SPIRE comments and or the following changes versus issue 2.2:

SPIRE CR's :

- HR-SP-RAL-ECR-032 : Removal of shutter
- HR-SP-RAL-ECR-049 : JFET 3D views (fig 5.4-3 & 5.4-4)
- HR-SP-RAL-ECR-048 v1 : dimension & mass of units, table in §5.5

- HR-SP-RAL-ECR-048 v2 : addendum to CR48v1 table §5.5 for DPU mass and SVM total mass , to reflect IHDR values
- HR-SP-RAL-ECR-009 v6 to v10 : not applied, replaced by new section 5.7 with annex 4 added as in H-P-ASP-MN-3513
- HR-SP-RAL-ECR-030 v3 : Temperature sensors table § 5.7.5.1 only applied, table § 5.7.5.3 replaced by ASED HF proposal dated 07/03
- HR-SP-RAL-ECR-050: SPIRE optical beam illustration fig 5.8-1
- HR-SP-RAL-ECR-046: Include HSDPU 1553B interface circuit §5.10.4.1
- HR-SP-RAL-ECR-029 v3: new harness definition, partially applied by SPIRE Harness definition document SPIRE-RAL-PRJ-000608 issue 1.1 (version 1.2 to be issued) as RD 19. Annex 3 (previously SPIRE-RAL-PRJ-000608 issue 1.1) replaced by "Summary of SPIRE cryoharness wiring functions", see H-P-ASP-MN-3513 and H-P-ASP-MN-3668
- HR-SP-RAL-ECR-039v1 : external and internal overshield function is agreed but with reference to HP-ASED-FX-0596-03 proposal in sections 5.10.1 & 5.10.2. common SPIRE/ASED text input. See H-P-ASP-MN-3513 and H-P-ASP-MN-3668
- HR-SP-RAL-ECR-033 : Update of various figures. Applied if not superseded by other CR (like CR 49, 29)
- HR-SP-RAL-ECR-040 v2: as ECR40 version v2 provided by SPIRE, the last ICD pack issue 6 is used as annex 1 (SPIRE-RAL-DWG-001409 issue 6). Waiting for next issue.
- HR-SP-RAL-ECR-041 v1: not applied. Section 7.2.1: text proposed by ASPI mail GL dated 21/11/02 is applied
- HR-SP-RAL-ECR-044 v1: not applied, according H-P-ASP-MN-3668
- HR-SP-RAL-ECR-052 v1: Spire Herschel DPU 28V Power I/F pin-out error: will be in annex 3 (and next issue 1.2 of SPIRE-RAL-PRJ-000608)
- HR-SP-RAL-ECR 053 v1, 057v2 & 058v2 : applied in § 5.6.1.2
- HR-SP-RAL-ECR 063 non official draft: partially applied with note to table in § 5.9.1

IIDB Sections :

- Section 0 : Table of contents modified in accordance with all section and annex changes
- Section 2 : list and numbering of AD and RD modified (and all corresponding references in all sections 3 to 10)
- Section 3: §3.1.3 Manager, § 3.2 table modified according SPIRE JD inputs
- Section 4: figure 4.1 modified, § 4.4 to 4.8.1 modified according SPIRE JD inputs
- Section 5: modified according previous listed CR's and various comments/inputs from SPIRE/ASED/ASP if not superseded by H-P-ASP-MN-3513 and H-P-ASP-MN-3668
- Section 5, notes added :
 - §5.4.2 and §5.4.3, fig 5.4-3 and fig 5.4-4: *HSJFP and HSJFS height*
 - §5.4.4.3, fig 5.4-8: : *figure and ICD/drawing to be updated...*
 - §5.5, table : (***) : *HSJFP and HSJFS height increase by +7.3mm ...*
- Section 6:
 - §6.1: TBD and waiting for inputs (notes added)
 - §6.2: 2 notes on SCOS 2000 are added
 - §6.3.1 modified according SPIRE JD inputs

- Section 7:
 - § 7.2.1: text proposed by ASPI mail GL dated 21/11/02 is applied
 - § 7.2.3: new sub-section added (Thermal on ground Test)
 - Other sub-sections:: TBD and waiting for inputs (notes added)
- Section 8: AD and RD modified
- Section 9:
 - §9.1 modified according SPIRE JD inputs
 - Other sub-sections:: TBD and waiting for inputs (notes added)
- Section 10: AD replaced by RD
- Annex 1 : SPIRE ICD/drawings new issue 6 , with added note "Forthcoming IID-B Annex 1 Unit ICDs Version 7" SPIRE-RAL-NOT-001822
- Annex 2 : SPIRE Reduced TMM new issue 2.3
- Annex 3 : new annex "Summary of SPIRE cryoharness wiring functions" added
- Annex 4 : new annex " Description of the Operation of the 3He Sorption Cooler" added
- Annex 5 : new annex " SPIRE HDD 1.1 Deltas" added

() Issue 3.1 changes versus issue 3.0:**

- This Section 0
- Section 5.4.2, figure 5.4-3, page 5-7: note suppressed
- Section 5.5, page 5-12: note (***) under table replaced by " *HSJFP and HSJFS height increase by about +7.3mm (bigger carbon fibre support for thermal I/F) is already included in Annex 1 (ICD's): updated table, CR and new drawings are to be issued by SPIRE.*
- Section 5.7.1:
 - Note on top page 5-18: ["L0 agreement meeting H-P-ASP-MN-3961" and "Spire IF meeting H-P-ASP-MN-3967", witch take precedence on] added between " ... in accordance with minutes of" and " SPIRE IIDB Convergence meeting ... "
 - § 5.7.1.3: New pages 5-19 & 5-20 and tables 5.7-1 & 5.7-2, according H-P-ASP-MN-3923
- Section 5.10: References to to previous Annex 5 corrected (§ 5.10, page 5-30)
- Section 5.15.1.2, page 5-44: "50 mBar/minute" replaced by "50 mBar/hour"
- Annex 1 : updated by SPIRE ICD/drawings new issue 8 , and added front page "ICD issue 8 drawings configuration and Industry comments"
- Annex 5 : updated by " SPIRE HDD 1.1 Deltas - Issue 3 " (SPIRE-RAL-NOT-001819, issue 3, 23/10/03)
- All pages of all sections : top of page « IIDB issue and date »

(*) Issue 3.11 changes versus issue 3.1:**

- This Section 0
- Section 2.1, pages 2-1: " _5_0" deleted in AD6 reference
- Section 5.7.3, page 5-21: " The units have an alochromed aluminium general surface finish. " deleted in 4th bullet of Note

- Section 5.9.6.1, page 5-27 “ Power requirements cannot be accepted until assumed margins are clearly stated. “ deleted in end of Note 1
- Section 5.11.4, page 5-40 , Reference HP-SPIRE-REQ-0230 : « AD tbd » is replaced by RD3
- Section 5.13.3, page 5-42 : Reference HP-SPIRE-REQ-0240 : section “5.7.5.2” is replaced by 5.7.5.3
- Section 7.2.1, page 7-3: Note 1 and all text « alternative text from SPIRE ?, new version of ECR 41 ? » deleted

(**) Issue 3.2 changes versus issue 3.11:**

- This Section 0
- General in all sections: change bars added highlighting the changes between this new version and the previous versions (PDR version 2.2 and intermediate versions 3.0 to 3.11)
- Section 2.1, page 2-1: « All Applicable Documents ... /IID-A/Applicable and Reference documents/ » is added
- Section 2.2, page 2-1: « All Reference Documents ... /livelink » is added
- Section 5, page 5-1 : sentence in bold “Spacecraft..... knowledge” is deleted
- Section 5.3.1.1, page 5-5 : In first sentence « 100 way » is replaced by « 128 way ». The second sentence “ESA is asked to advise ... herein” is deleted.
- Section 5.4.3, page 5-8 : note “HSJFP and..... by SPIRE” is deleted
- Section 5.5, page 5-12 : first sentence, “The mass budget.....following table” and “ Note : SPIRE CR 48 ... table” are deleted . The (***) marks in table and the note under table “ (***) : HSJFP and HSJFS.... ” are deleted.
- Section 5.6.1.2, page 5-13 : The “Note : SPIRE ECR-053 v1, 057v2 & 058v2 ... section 5.6.1.2” is deleted
- Section 5.6.3, page 5-16 : in last sentence “ The Spire warm harness ...”, “ ... TBD ESA provided hold-down ties” is replaced by “ ... TBD devices provided by Industry ”
- Section 5.7.1.3, page 5-19 : note under table 5.7-1 : “ ...in sequence, refer to Annex 4” is replaced by “...in sequence, see Annex 4 for information”
- Section 5.11.1.1, page 5-37 : ref HP-SPIRE-REQ-0150 is changed to: “SPIRE requires an average of 100 kbps of TM data rate during operations, and 2.5 kbps when in stand-by mode”
- Section 5.11.1.2, page 5-37 : ref HP-SPIRE-REQ-0160, “TBC” is added after 200 kbps
- Section 5.11.3, page 5-38 : “ Spire requires ... smallest pixel IFOV” is moved in section 5.12.2 page 5-41
- Section 5.12.1, page 5-41 : bullet point 4, the bracket “(this is not.....value is 2)” is deleted. Bullet point 5, after “ ... with steps of between” the value 1.7 is changed to 2 arcsec and the bracket “(this is not.....value is 2)” is deleted.
- Section 5.14.3, page 5-43 : first sentence “The original..... has been dropped” is deleted.
- Annex 1, Annex 1.1 : the main table in front page is modified (no more previous drawings references) and note (i) with small table (previous drawings references) is added

1. INTRODUCTION

The purpose of the Instrument Interface Documents (IIDs) is to define and control the overall interface between each of the Herschel/Planck scientific instruments and the Herschel/Planck spacecraft.

The IIDs consist of two parts, IID-A and IID-B. There is one part A, covering the interfaces to all Herschel and Planck instruments, and one IID-B per instrument:

- The IID-A describes the implementation of the instrument requirements in the design of the spacecraft and will be a result of the spacecraft design activities performed by the Contractor.

- Each IID-B is the result of a specific instrument's design activity. In its 'interface' section (chapter 5) are defined the requirements of the instrument and the resources to be provided by the spacecraft. In its 'performance' section (last section of chapter 4) it defines the scientific performance requirements of the instrument as part of the scientific mission requirements and as agreed between the Principal Investigators and ESA.

After issue 2/0 by ESA, the Contractor will be responsible for maintenance and configuration control of the IIDs in agreement with, and after approval by, the Instruments Principal Investigators and ESA.

In case of conflict between the contents of the IID-A and the IID-Bs, the agreement or definition in the IID-B shall take precedence.

The IIDs will not cover any of the interfaces of the Instrument Control Centres (ICCs for Herschel), the Data Processing Centres (DPCs for Planck) or the Herschel Science Centre (HSC).

2. APPLICABLE/REFERENCE DOCUMENTS

2.1 APPLICABLE DOCUMENTS

All Applicable Documents hereafter are available (with IIDA) on ASP ftp site :

[ftp://ftp.hp-instruments.as-b2b.com/industry_to_instruments/IIDs/IID-A/Applicable and Reference documents/](ftp://ftp.hp-instruments.as-b2b.com/industry_to_instruments/IIDs/IID-A/Applicable_and_Reference_documents/)

- AD 1** Herschel/Planck Instrument Interface Document Part A. : Ref. SCI-PT-IIDA-04624
- AD 2** Product Assurance Requirements for Herschel/Planck Scientific Instruments Ref. SCI-PT-RQ-04410
- AD 3** Herschel/Planck Operations Interface Requirements Document OIRD Ref. SCI-PT-RS-07360.
- AD 4** Herschel Science-operations Implementation Requirements Document - SIRD Ref. SCI- PT-03646
- AD 5** Herschel/Planck Packet Structure Interface Control Document - PSICD Ref SCI-PT-ICD-07527
- AD 6** Telescope specification / Herschel: SCI- PT-RS-04671
- AD 7** Alignment Plan-Concept / Herschel: Ref. HP-2-ASED-TN-0002 (Annex of AD1)
- AD 8** Software standard: ECSS E 40 B

2.2 REFERENCE DOCUMENTS

All Reference Documents hereafter are available on ESA livelink:

<http://www.rssd.esa.int/l/ink/livelink?func=ll&objId=26764&objAction=browse&sort=name>

- RD 1** SPIRE Instrument Design Description SPIRE-RAL-PRJ-000620
- RD 2** SPIRE Instrument Requirements Document (IRD) SPIRE-RAL-PRJ-000034
- RD 3** SPIRE Data ICD, SPIRE-RAL-PRJ-001078 (covers both telemetry and command data)
- RD 4** SPIRE Management Plan, SPIRE-RAL-PRJ-000029
- RD 5** SPIRE Science Requirements Document (SRD) SPIRE-UCF-PRJ-000064
- RD 6** SPIRE Instrument AIV Plan, SPIRE-RAL-DOC -000410
- RD 7** SPIRE Product Assurance Plan SPIRE-RAL-PRJ-000017.
- RD 8** SPIRE Block Diagram SPIRE-RAL-DWG-000646
- RD 9** SPIRE product tree
- RD 10** Instrument WBS (inside RD4)
- RD 11** Instrument Science Implementation plan
- RD 12** SPIRE Grounding and Screening Philosophy SPIRE-RAL-PRJ-000624
- RD 13** SPIRE CRYOGENIC INTERFACE THERMAL MATHEMATICAL MODEL (ITMM) SPIRE-RAL-PRJ-000728
- RD 14** Instrument reduced FRM Model
- RD 15** Spire Straylight References SPIRE-RAL-NOT-001124
- RD 16** Swinyard. B , Power profiles for SPIRE operating modes, RAL-NOT-000068
- RD 17** SPIRE Operating Modes, SPIRE RAL-PRJ-000320
- RD 18** SPIRE Thermal Configuration Control Document, SPIRE-RAL-PRJ-000560
- RD 19** Herschel SPIRE Harness Definition, SPIRE-RAL-PRJ-000608

RD 20 Spire requirements on Cryostat Apertures SPIRE-RAL-NOT-01242

RD 21 Matching SPIRE - HOB Decentre and tilt amplitudes to the Photometer pupil alignment budget SPIRE-RAL-NOT-000754

2.3 LIST OF ACRONYMS

AD	Applicable Document
AO	Announcement of Opportunity
AVM	Avionics Verification Model
BSM	Beam Steering Mechanism
CCE	Central Check-Out Equipment
CDMS	Command and Data Management Subsystem
CQM	Cryogenic Qualification Model
CV	Cryostat Vacuum Vessel
DPU	Digital Processing Unit
DRCU	Detector Readout and Control Unit
EGSE	Electrical Ground Support Equipment
EMC	Electro-Magnetic Compatibility
ESA	European Space Agency
Herschel	Far InfraRed and Submillimetre Telescope (FIRST)
FM	Flight Model
FOV	Field Of View
FTS	Fourier Transform Spectrometer
GSE	Ground Support Equipment
HIFI	Heterodyne Instrument for the Far Infrared
HSC	Herschel Science Centre
IA	Interactive Analysis
ICC	Instrument Control Centre
ICD	Interface Control Document
IID	Instrument Interface Document
ISO	Infrared Space Observatory
JFET	Junction Field Effect Transistor
KAL	Keep Alive Line
LOU	Local Oscillator Unit (HIFI)
MGSE	Mechanical Ground Support Equipment
MOC	Mission Operations Centre
NEP	Noise Equivalent Power
OBS	On Board Software

OGSE	Optical Ground Support Equipment
OIRD	Operations Interface Requirements Document
OTF	On-Target Flag
PACS	Photoconductor Array Camera and Spectrometer (Herschel)
PFM	Proto Flight Model
QLA	Quick Look Analysis (software)
RAM	Random Access Memory
RD	Reference Document
RF	Radio Frequency
ROM	Read Only Memory
RTA	Real Time Assessment (software)
S/C	Spacecraft
SCOS	Spacecraft Control and Operations System
SIRD	Science –Operations Implementation Requirements Document
SPIRE	Spectral Photometer Imaging Receiver
SPU	Signal Processing Unit
SRD	Software Requirements Document
SVM	Service Module
TBC	To be confirmed
TBD	To be determined
TBW	To be written

3. KEY PERSONNEL AND RESPONSIBILITIES

3.1 KEY PERSONNEL

3.1.1 Principal Investigator

Prof. Matt Griffin
Department of Physics and Astronomy
University of Wales, Cardiff
Cardiff CF24 3YB
United Kingdom

Telephone (Institute) : +44-(0)29-2087-4203
Telefax : +44-(0)29-2087-4056
E-mail : matt.griffin@.astro.cf.ac.uk

3.1.2 Co-Principal Investigator

Dr. Laurent Vigroux
CEA - Service d'Astrophysique
CEA Saclay, Bat. 709
Orme des Merisiers
91191 Gif sur Yvette
France

Telephone (Institute) : +33-1-69-08-3912
Telefax : +33-1-69-08-6577
E-mail : lvigroux@cea.fr

3.1.3 Instrument Manager

Dr. Eric Sawyer
Rutherford Appleton Laboratory
Chilton, Didcot
Oxfordshire OX11 0QX
England

Telephone (Institute) : +44-1235-44-6385
Telephone (Home) :

Telefax : +44-1235-44-6667
E-mail : E.C.Sawyer@rl.ac.uk

3.2 RESPONSIBILITIES

INSTITUTE	RESPONSIBILITIES
ATC, Edinburgh	Beam steering mechanism
CEA, Grenoble	³ He cooler
CEA, SAp, Paris	Detector Readout and Control Unit (DRCU); ICC DAPSAS Centre;
DESPA, Paris	FTS expertise and design support
GSFC, Maryland	FTS Expertise and design support;
IAS, Paris	Ground Calibration support
ICSTM, London	ICC UK DAPSAS Centre
IFSI, Rome	Digital Processing Unit (DPU) and related On-board S/W
JPL/Caltech, California	Bolometer arrays and associated cold readout electronics
LAM, Marseille	Optics; FTS mechanism
MSSL, Surrey	Focal Plane Unit Structure
University of Wales, Cardiff	Focal plane array testing; filters, dichroics, beam dividers
RAL, Oxfordshire	Project management and Project Office, System and Thermal Engineering; AIV and ground calibration facilities; ICC Operations Centre
Stockholm Observatory	Instrument simulator; DRCU Simulator
University of Padua	Provision of ICC Operations Staff
University of Saskatchewan	OGSE Fourier Spectrometer + Science Support

INSTITUTE	LOCAL MANAGER	TELEPHONE / FAX EMAIL	ADDRESS
ATC	Phil Parr Burman	Tel.+44-131-668-8260 Fax:+44-131-668-8382 E-mail: ppb@roe.ac.uk	Royal Observatory Blackford Hill, Edinburgh EH9 3HJ, Scotland
CEA, Grenoble	Lionel Duband	Tel.+33-4-38-78-41-34 Fax:+33-4-38-78-51-71 E-mail: Duband@drfmc.ceng.cea.fr	CEA- Grenoble Service des Basses Températures 17 av. des Martyrs 38054 Grenoble Cedex, France
CEA, SAp	Jean-Louis Augueres	Tel.: +33-1-6908-3058 Fax: +33-1-69-08-6577 E-mail:augueres@cea.fr	CEA - Service d'Astrophysique CEA Saclay, Bât. 709 Orme des Merisiers 91191 Gif sur Yvette, France
IAS	Francois Pajot	Tel.+33-1-69-85-8567 Fax:+33-1-69-85-8675 E-mail: Francois.Pajot@ias.fr	Institut d'Astrophysique Spatiale Bât. 121, Université Paris Sud 91405 Orsay, Paris, France
ICSTM	Tim Sumner	Tel.+44-207-594-7552 Fax:+44-207-594-3465 E-mail: t.sumner@ic.ac.uk	Blackett Laboratory Imperial College, Prince Consort Rd. London SW7 2BZ, England
IFSI	Riccardo Cerulli- Irelli	Tel.+39-6-4993-4377 Fax:+39-6-4993-4383 E-mail: Cerulli@ifsi.rm.cnr.it	Inst. di Fisica dello Spazio Interplanetario, CNR Area di Ricerca Tor Vegata via Fosso del Cavaliere 00133-Roma, Italy
JPL/Caltech	Marty Herman	Tel. + 1 818 354 8541 Fax: . + 1 818 393 6984 E-mail: Martin.E.Herman@jpl.nasa.gov	Jet Propulsion Laboratory Pasadena, CA 91109, USA

INSTITUTE	LOCAL MANAGER	TELEPHONE / FAX EMAIL	ADDRESS
LAM	Dominique Pouliquen	Tel. +33-4-91-05-5949 Fax: +33-4-91-05-6959 E-mail: Dominique.pouliquen @astrsp- mrs.fr	Laboratoire d'Astrophysique de Marseille BP 8, 13376 Marseille Cedex 12 France
MSSL	Berend Winter	Tel. +44-1483-204-215 Fax: +44- E-mail: bw@mssl.ucl.ac.uk	Mullard Space Science Laboratory Holmbury St. Mary, Dorking, Surrey RH5 6NT, England
University of Wales, Cardiff	Peter Hargrave	Tel. +44-29-2087-6067 Fax: +44-29-2087-6682 E-mail: p.hargrave@astro.cf.ac.uk	Department of Physics and Astronomy University of Wales, Cardiff Cardiff CF24 3YB United Kingdom
RAL	Ken King	Tel. +44-1235-44-6558 Fax: +44-1235-44-6667 E-mail: k.j.king@rl.ac.uk	Rutherford Appleton Laboratory Chilton, Didcot Oxfordshire OX11 0QX, England
Stockholm Obs.	H G Floren	Tel. +46-8-5537-8522 Fax: +46-8-5537-8510 E-mail: floren@astro.su.se	Stockholm Observatory S-133 36 Saltsjöbaden Sweden
University of Padua	Paola Andreani	Tel. +39-49-829-TBD Fax: +39-49-875-9840 E-mail: andreani@astrpd.pd.astro.it	Dipartimento di Astronomia di Padova vicolo Osservatorio 5 I-35122 Padova, Italy

4. INSTRUMENT DESCRIPTION

4.1 INTRODUCTION

For low background direct detection at wavelengths longer than around 200 μm , the most sensitive detectors are cryogenic bolometers operating at temperatures in the 0.1 - 0.3 K range.

SPIRE (Spectral & Photometric Imaging REceiver) is a bolometer instrument comprising a three-band imaging photometer covering the 200-500 μm range and an imaging Fourier Transform Spectrometer (FTS) with a spectral resolution of at least 0.4 cm^{-1} (corresponding to $\lambda/\Delta\lambda = 100$ at 250 μm , covering wavelengths between 200 and 670 μm). The detectors are bolometer arrays cooled to 300 mK using a ^3He refrigerator. The photometer is optimised for deep photometric surveys, and can observe simultaneously the same field of view of 4 x 8 arcminutes in all three bands.

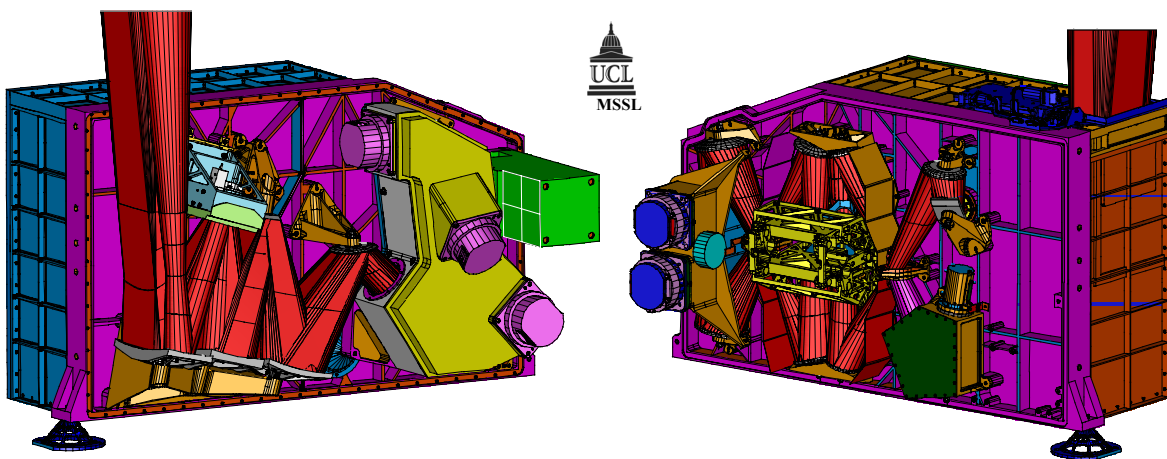

Figure 4-1: Two halves of Spire: photometer shown on left, spectrometer on the right"

4.2 SCIENTIFIC RATIONALE

The wavelength range 200 - 700 μm is largely unexplored. The thermal emission from many astrophysical sources peaks in this part of the spectrum, including comets, planets, star-forming molecular cloud cores, and starburst galaxies. The short submillimetre region is also rich in atomic and molecular transitions which can be used to probe the chemistry and physical conditions in these sources.

Wavelengths between 200 and 350 μm are not observable from the ground and have not been observed by ISO. Between 350 μm and 700 μm , some low transparency submillimetre windows allow some observations to be made with difficulty from the ground, but with far lower sensitivity than can be achieved from space.

One of the most important scientific projects for the Herschel mission is to investigate the statistics and physics of galaxy formation at high redshift. This requires the ability to carry out deep photometric imaging at far-infrared and submillimetre wavelengths to discover objects, and the ability to follow up the survey observations with spectroscopy of selected sources. The Herschel SPIRE instrument is essential for this

programme, and is being designed so as to be optimised for these extragalactic imaging and spectral surveys. Another key scientific project for SPIRE is a sensitive unbiased search for proto-stellar objects within our own galaxy. This will also be followed up by spectral observations using SPIRE, other Herschel instruments and ground-based facilities.

4.3 INSTRUMENT OVERVIEW

SPIRE contains a three-band imaging photometer and an imaging Fourier Transform Spectrometer (FTS), both of which use 0.3-K "spider-web" NTD germanium bolometers cooled by a ^3He refrigerator. The bolometers are coupled to the telescope by close-packed single-mode conical feedhorns. The photometer and spectrometer are not designed to operate simultaneously. The field of view of the photometer is 4×8 arcminute, the largest that can be achieved given the location of the SPIRE field of view in the Herschel focal plane and the size of the telescope unvignetted field of view. Three photometer arrays provide broad-band photometry ($\lambda/\Delta\lambda \approx 3$) in wavelength bands centred on 250, 350 and 500 μm . The 250, 350 and 500 μm arrays have 149, 88, and 43 detectors respectively, making a total of 280. The field of view is observed simultaneously in all three bands through the use of fixed dichroic beam-splitters. Spatial modulation can be provided either by a Beam Steering Mirror (BSM) in the instrument or by drift scanning the telescope across the sky, depending on the type of observation. An internal thermal calibration source is available to provide a repeatable calibration signal for the detectors. The FTS uses novel broadband intensity beam dividers, and combines high efficiency with spatially separated input ports. One input port covers a 2.6-arcminute diameter field of view on the sky and the other is fed by an on-board calibration source which serves to null the thermal background from the telescope and to provide absolute calibration. Two bolometer arrays are located at the output ports, one covering 200-300 μm and the other 300-670 μm . The FTS will be operated in continuous scan mode, with the path difference between the two arms of the interferometer being changed by a constant-speed mirror drive mechanism. The spectral resolution, as determined by the maximum optical path difference, will be adjustable between 0.04 and 2 cm^{-1} (corresponding to $\lambda/\Delta\lambda = 1000 - 20$ at 250 μm wavelength).

The focal plane unit has three separate temperature stages at nominal temperatures of 4 K, 2 K (provided by the Herschel cryostat) and 300 mK (provided by SPIRE's internal cooler). The main 4-K structural element of the FPU is an optical bench panel which is supported from the cryostat optical bench by stainless steel blade mounts. The photometer and spectrometer are located on either side of this panel. The majority of the optics are at 4 K, but the detector arrays and final optics are contained within 2-K enclosures. The ^3He refrigerator cools all of the five detector arrays to 0.3 K. Two JFET preamplifier modules (one for the photometer and one for the FTS) are attached to the optical bench close to the 4-K enclosure, with the JFETs heated internally to their optimum operating temperature of ~ 120 K.

The SPIRE warm electronics consist of two boxes with direct connection to the FPU, the Detector Control Unit (DCU) and the Focal Plane Control Unit (FCU) (together these boxes are termed the Detector Readout and Control Unit (DRCU)) plus a Digital Processing Unit (DPU) with interfaces to the other two boxes and the spacecraft data handling system. The DCU provides bias and signal conditioning for the detector arrays and cold readout electronics and reads out the detector signals. The FCU controls the FPU mechanisms and the ^3He cooler and handles housekeeping measurements. The DPU acts as the interface to the spacecraft, including instrument commanding and formats science and housekeeping data for telemetry to the ground.

4.4 HARDWARE DESCRIPTION

The SPIRE instrument consists of:

HSFPU	<p>Focal Plane Unit (FPU):</p> <p>This interfaces to the cryostat optical bench, and the 4-K and 2-K temperature stages provided by the cryostat. Within the unit, further cooling of the detector arrays to a temperature of around 300 mK is provided by a ³He refrigerator which is part of the instrument.</p>
HSJFP	<p>JFET box for the photometer detectors</p> <p>This box is mounted on the optical bench next to the photometer side of the FPU and contains JFET preamplifiers for the detector signals. The JFETs operate at around 120 K, and are thermally isolated inside the enclosure.</p>
HSJFS	<p>JFET box for the spectrometer detectors</p> <p>This box is mounted on the optical bench next to the spectrometer side of the FPU and contains JFET preamplifiers for the detector signals. The JFETs operate at around 120 K, and are thermally isolated inside the enclosure.</p>
HSDCU	<p>Detector Control Unit (on Herschel SVM)</p> <p>A warm analogue electronics box for detector read-out analogue signal processing, multiplexing, A/D conversion, and array sequencing.</p>
HSFCU	<p>Focal Plane Control Unit (on Herschel SVM)</p> <p>A warm analogue electronics box for mechanism control, temperature sensing, general housekeeping and ³He refrigerator operation. It conditions secondary power both for itself and for the DCU.</p>
HSDPU	<p>Digital Processing Unit (on Herschel SVM)</p> <p>A warm digital electronics box for signal processing and instrument commanding and interfacing to the spacecraft telemetry.</p>
HSWIH	<p>Warm interconnect harness (on Herschel SVM)</p> <p>Harness making connections between SPIRE electronics boxes.</p>

4.5 SOFTWARE DESCRIPTION

The SPIRE OBS will carry out the following functions:

- Read and log housekeeping data and packetise the data that these produce.
- Control and monitor the instrument mechanisms and internal calibration sources
- Carry out pre-defined observing sequences
- Implement pre-defined procedures on detection of instrument anomalies

The on-board software (OBS) will be written in "C" language and will be designed to allow the instrument to operate in an autonomous fashion for 48 hours as required in the IID-A. The basic implication of this requirement is that there must be the facility to store enough commands for a 48 observing programme and enough mass memory on the satellite to store 48 hours of instrument telemetry. More sophisticated autonomy functions may include the on-board analysis of scientific or housekeeping data and the ability to react on the basis of that analysis. The type of automatic operation undertaken following such an analysis may range from the raising of a warning flag to the switching over to a redundant sub-system or the switching off of a defective sub-system. All autonomy functions will require extensive evaluation and test before they are implemented to avoid the possibility of instrument failure. No instrument autonomy mode will be implemented that will affect the satellite operation.

Commands defined in RD5 and conforming to AD5 will be sent via a HERSCHEL 1553 bus to the active HSDPU. The Spire OBS in the HSDPU will verify and then interpret these commands. Many will result in a sequence of internal digital commands which are then sent with appropriate timings to the HSDCU and/or the HSFCU.

A detailed description of the on-board software will be given in Chapter 5

4.6 OPERATING MODES

This section gives a brief description of the operating modes for the SPIRE instrument.

For latest information, refer to RD 17.

4.6.1 OFF Mode

All instrument sub-systems will be switched off - including the DPU and there will be no instrument telemetry.

4.6.2 Initialise (INIT) Mode

This is an intermediate mode between OFF and ON. This will be the mode the instrument enters after a power on or re-boot. In this mode only a limited sub-set of commands may be executed. This mode allows updates of DPU on-board software and/or tables to be carried out safely before they are used for instrument control.

4.6.3 ON Mode

The DPU will be switched on and can receive and interpret all instrument commands, but no other sub-systems will be switched on (including the DRCU). For engineering purposes it will be possible to command the instrument to switch on individual sub-systems from this mode. Full DPU housekeeping data will be telemetered.

4.6.4 Ready (REDY) Mode

The DPU and DRCU are powered on and the on-board software is ready to receive commands. No other sub-systems are switched on in this mode. DRCU housekeeping data will be telemetered.

4.6.5 Standby (STBY) Mode

The spacecraft may be pointed in an arbitrary direction (observing with another instrument for instance). The instrument will telemeter only housekeeping information, and perhaps some degraded science data -see below, at a rate very much lower than the full telemetry bandwidth. This is presently baselined to be the photometer detectors on and at 300 mK i.e. the cooler will have been recycled previous to entering STANDBY. All other sub-systems will be switched off.

4.6.6 Observe Mode (OBSV) Mode

There are two basic sub-modes for the observe mode Photometer and Spectrometer. The details of the OBSERVATIONS to be carried out in OBSERVE mode are given in section 4.7.

4.6.7 Cooler Recycle (CREC) Mode

The ³He cooler requires recycling every 46 hours (TBC). During this time the instrument will be switched off except for vital housekeeping and cooler functions (TBC).

4.6.8 SAFE Mode

The instrument will be switched to SAFE mode in the event of any anomalous situation occurring whilst in autonomous operation. This will be with the DPU on having been rebooted from a restricted set of software stored in ROM.

4.7 OBSERVING MODES

The spacecraft will be pointed in a specific direction or, for mapping, will either slew slowly over a given region of the sky, or execute a raster pattern by movements of the telescope. The instrument will take scientifically meaningful data and use the full telemetry bandwidth. It is assumed that any calibrations required will also be done in the observe mode (TBC).

For latest information, refer to RD 17.

4.7.1 Photometer Observing Modes

The photometer can carry out essentially three kinds of observation: chopping, jiggling, and scanning, and it is envisaged that these will form the basis of three

Astronomical Observation Templates (AOTs) to allow astronomers to specify their observations. The three kinds of observation are implemented as 6 (TBC) observing modes, named POFs (Photometer Observatory Functions), which are briefly described below. Provision is also made for additional POFs for peak-up and special engineering modes.

4.7.1.1 Observation: Point Source Photometry

POF1 Chop without jiggling:

This mode is for point source observations with reliable telescope pointing. The SPIRE Beam Steering Mechanism is used to chop between two positions on the sky at a frequency of typically 2 Hz. The telescope may optionally be nodded with a nod period of typically three minutes.

POF2 Seven-point jiggle map:

This mode is for point source observations for which the telescope pointing or the source co-ordinates are not deemed sufficiently accurate. The SPIRE BSM chops and also executes a seven-point map around the nominal position. Nodding is optional.

4.7.1.2 Observation: Jiggle Map

POF3 n-point jiggle map:

This mode is designed for mapping of extended sources. It is similar to POF2 except that the nominal value of n is 64 rather than 7. It produces a fully sampled map of a 4 x 4 arcminute area.

POF4 Raster map:

This is the same as POF3 except that maps of large regions can be built up by using the telescope rastering capability.

4.7.1.3 Observation: Scan Map

POF5 Scan map without chopping:

This mode is used for mapping areas much larger than the SPIRE field of view. The SPIRE BSM is inactive, and the spacecraft is scanned continuously across the sky to modulate the detector signals.

POF6 Scan map with chopping:

This mode is the same as POF5 except that the SPIRE BSM implements chopping. It allows for the possibility of excess 1/f noise by permitting signal modulation at frequencies higher than POF5.

4.7.1.4 Others

POF7 Photometer peak-up (TBD):

This mode allows the necessary pointing offsets to be determined in order to allow implementation of POF1

rather than POF2. The observation itself is the same as POF3. On completion, the SPIRE DPU computes the offsets between the telescope pointed position and the source peak emission, and sends this information to the spacecraft, which can then implement the necessary pointing corrections.

POF8 Operate photometer calibrator:

The SPIRE photometer internal calibrator is energised with a pre-determined sequence and the corresponding detector signals are recorded.

POF9 Special engineering/commissioning modes (TBD).

4.7.2 Spectrometer Observing Modes

There are two kinds of spectrometer observation: point source and fully sampled map. The latter is carried out by repeating the former at a number of separate pointing using the SPIRE BSM (or, alternatively the spacecraft in RASTER Pointing mode). These are implemented as two Spectrometer Observatory Functions (SOFs):

SOF1: Point source spectrum

SOF2: Fully sampled spectral map

In all cases, the telescope pointing and/or Beam Steering Mirror position are kept fixed while the FTS mirror is scanned a predetermined number of times to generate interferograms from which the source spectrum can be derived.

4.7.3 Other Modes

4.7.3.1 Photometer Serendipity

During spacecraft slews scientifically useful information can be obtained without the necessity of using the focal plane chopper - essentially these are rapid scan maps. The chopper and spectrometer mechanisms will be switched off in this mode. Accurate pointing information will be required from the AOCS to reconstruct the slew path in the data analysis on the ground.

4.7.3.2 Photometer Parallel

When observations are being made with PACS, scientifically useful data may be obtainable from the photometer, albeit with degraded sensitivity and spatial resolution. In this mode a science data packet will be telemetered alongside the standard housekeeping data. The chopper and spectrometer mechanisms will be switched off in this mode. The feasibility and scientific desirability of this mode is TBD.

4.7.4 Real-Time Commanding

During ground contact it may be necessary to command the instrument in real time and analyse the resultant data on the ground in near real time for instrument testing and debugging purposes. In this case the full telemetry bandwidth will be required for the duration of the instrument test in question. It is not anticipated that this will occur frequently.

4.7.5 Commissioning/calibration Mode

During the commissioning and performance verification phases of mission operations, many housekeeping and other health check parameters will be unknown or poorly defined. This mode allows the limits on selected health check parameters to be ignored by whatever real time monitoring systems are in place on the spacecraft/instrument.

4.7.6 FPU operations at Ambient Temperature

TBD. It is anticipated that functional checks will be possible for mechanisms and housekeeping lines. The detectors will not function at ambient temperature. Limited verification of the readout electronics may be possible.

4.7.7 FPU Orientation

During ground tests the FTS mechanism can only operate when the FPU is on its side. In addition, there is a restriction on the orientation of the ³He cooler during recycling.

4.8 INSTRUMENT REQUIREMENTS AND PERFORMANCE SPECIFICATION

4.8.1 Scientific Requirements

The scientific performance requirements for SPIRE are summarised in the *SPIRE Scientific Requirements Document* as follows:

Requirement SRD-R 1: The photometer should be capable of diffraction-limited extragalactic blind surveys of at least 60 sq. deg. of the sky, to 1- σ detection limit of 3 mJy in all bands with an observing time of six months or less.

Requirement SRD-R 2: The photometer should be capable of a galactic survey covering 1 deg. sq. to a 1- σ depth of 3 mJy at 250 μ m within an observing time of one month or less.

Requirement SRD-R 3: Maximising the mapping speed at which confusion limit is reached over a large area of sky is the primary science driver. This means maximising sensitivity and field-of-view (FOV) but NOT at the expense of spatial resolution.

Requirement SRD-R 4: The photometer observing modes should provide a mechanism for telemetering undifferenced samples to the ground.

Requirement SRD-R 5: The photometer should have an observing mode that permits accurate measurement of the point spread function.

Requirement SRD-R 6: Optical field distortion should be less than 10% across the photometer field of view.

Requirement SRD-R 7: The photometer field of view shall be at least 4 x 4 arcminutes, with a goal of 4 x 8 arcminutes.

Requirement SRD-R 8: For $2F\lambda$ feedhorns, crosstalk shall be less than 1% (goal 0.5%) for adjacent detectors and 0.1% or less (goal 0.05%) for all non-adjacent detectors in the same array; for $0.5F\lambda$ pixels, the requirement is 5% (goal 2%) to adjacent detectors and 0.1% (goal 0.05%) to all others.

Requirement SRD-R 9: The maximum available chop throw shall be at least 4 arcminutes; the minimum shall 10 arcseconds or less.

Requirement SRD-R 10: The rms detector NEP variation across any photometer array should be less than 20%.

Requirement SRD-R 11: The photometer dynamic range for astronomical signals shall be 12 bits or higher.

Requirement SRD-R 12: SPIRE absolute photometric accuracy shall be 15% or better at all wavelengths, with a goal of 10%.

Requirement SRD-R 13: The relative photometric accuracy should be 10% or better with a goal of 5%.

Requirement SRD-R 14: SPIRE photometric measurements shall be linear to 5% over a dynamic range of 4000 for astronomical signals.

Requirement SRD-R 15: For feedhorn detectors, the overlapping sets of three detectors at the three wavelengths should be co-aligned to within 2.0 arcseconds on the sky (goal is 1.0 arcsecond).

Requirement SRD-R 16: The spectrometer design shall be optimised for optimum sensitivity to point sources, but shall have an imaging capability with the largest possible field of view that can be accommodated.

Requirement SRD-R 17: The sensitivity of the FTS at any spectral resolution up to the goal value shall be limited by the photon noise from the Herschel telescope within the chosen passband.

Requirement SRD-R 18: The spectrometer dynamic range for astronomical signals shall be 12 bits or higher.

Requirement SRD-R 19: The FTS absolute accuracy shall be 15% or better at all wavelengths, with a goal of 10%.

Requirement SRD-R 20: The FTS shall be capable of making spectrophotometric measurements with a resolution of 2 cm^{-1} , with a goal of 4 cm^{-1} .

Requirement SRD-R 21: The width of the FTS instrument response function shall be uniform to within 10% across the field of view.

Requirement SRD-R 22: The maximum spectral resolution of the FTS shall be at least 0.4 cm^{-1} with a goal of 0.04 cm^{-1} .

Requirement SRD-R 23: The SPIRE photometer shall have an observing mode capable of implementing a 64-point jiggle map to produce a fully sampled image of a 4 x 4 arcminute region.

Requirement SRD-R 24: The photometer observing modes shall include provision for 5-point or 7-point jiggle maps for accurate point source photometry.

Requirement SRD-R 25: The photometer shall have a "peak-up" observing mode capable of being implemented using the beam steering mirror.

4.8.2 Instrument Performance Estimates

4.8.2.1 Assumptions

The sensitivity of SPIRE has been estimated under the assumptions listed in Table 4.1.

Telescope temperature (K)	80		
Telescope emissivity	0.04		
Telescope used diameter (m) (1)	3.29		
No. of observable hours per 24-hr period	21		
Photometer			
Bands (μm)	250	350	500
Numbers of detectors	139	88	43
Beam FWHM (arcsec.)	17	24	35
Bolometer DQE (2)	0.6	0.7	0.7
Throughput	λ^2		
Bolometer yield	0.8		
Feed-horn/cavity efficiency (3)	0.7		
Field of view (arcmin.)	Scan mapping	4 x 8	
	Field mapping	4 x 4	
Overall instrument transmission	0.3		
Filter widths ($\lambda/\Delta\lambda$)	3.3		
Observing efficiency (slewing, setting up, etc.)	0.9		
Chopping efficiency factor	0.45		
Reduction in telescope background by cold stop (4)	0.8		
FTS spectrometer			
Bands (μm)	200-300	300-670	
Numbers of detectors	37	19	
Bolometer DQE	0.6	0.7	
Feed-horn/cavity efficiency	0.70		
Field of view diameter (arcmin.)	2.6		
Max. spectral resolution (cm ⁻¹)	0.04		
Overall instrument transmission	0.15		
Signal modulation efficiency	0.5		
Observing efficiency	0.8		
Electrical filter efficiency	0.8		

Table 4.1: Assumptions for SPIRE Performance Estimation

Notes:

1. The telescope secondary mirror is the pupil stop for the system, so that the outer edges of the primary mirror are not seen by the detectors. This is important to make sure that radiation from highly emissive elements beyond the primary reflector does not contribute stray light.
2. The bolometer DQE (Detective Quantum Efficiency) is defined as : $[NEP_{ph}/ NEP_{Total}]^2$, where NEP_{ph} is the photon noise NEP due to the absorbed radiant power and NEP_{Total} is the overall NEP including the contribution from the bolometer noise.
3. This is the overall absorption efficiency of the combination of feed-horn, cavity and bolometer element.
4. A fraction of the feedhorn throughput falls outside the solid angle defined by the photometer 2-K cold stop and is thus terminated on a cold (non-emitting) surface rather than on the 4% emissive 80-K telescope. This reduces the background power on the detector.

The background power levels on the SPIRE detectors (dominated by the telescope emission), and the corresponding photon noise limited NEP values are given in Table 4.2.

		Photometer band			FTS band (μm)	
		250	350	500	200-300	300-670
Background power/detector	pW	3.9	3.2	2.0	6.0	11
Background-limited NEP	$W Hz^{-1/2} \times 10^{-17}$	8.1	6.1	4.5	10	11
Total NEP (inc. detector)	$W Hz^{-1/2} \times 10^{-17}$	10	7.3	5.4	12	14

Table 4.2: Background Power and Photon Noise Levels

The estimated sensitivity levels for SPIRE are summarised in Table 4.3. The figures quoted are the nominal values, with an overall uncertainty of around 50% to take into account uncertainties in instrument parameters, particularly feedhorn efficiency, detector DQE, and overall transmission efficiency. The pixel size will be increasingly mis-matched to the diffraction spot size. The trade-off between wavelength coverage and sensitivity of the long-wavelength FTS band must be studied in detail. At the moment, we estimate an effective loss of efficiency of a factor of two at 670mm, and scale linearly for wavelengths between 400 and 670 mm. Performance beyond 400 mm may have to be compromised to maintain the desired sensitivity below 400 mm.

Table 4.3: SPIRE Estimated Sensitivity

Photometry					
λ	μm		250	350	500
$\Delta S(5-\sigma; 1\text{-hr})$	mJy	Point source (7-point) ode)	2.5	2.6	2.9
		4' x 4' jiggle map	8.8	8.7	9.1
		4' x 8' scan map	7.3	7.2	7.5
Time (days) to map 1 deg. ² to 3 mJy 1- σ		1° x 1° scan map	1.8	1.7	1.9

Line spectroscopy $\Delta\sigma = 0.04 \text{ cm}^{-1}$					
λ	μm		200	400	670
$\Delta S (5-\sigma; 1\text{-hr})$	$\text{W m}^{-2} \times 10^{-17}$	Point source	3.4	3.9	7.8
		2.6' map	9.0	10	21

Low-resolution spectrophotometry $\Delta\sigma = 1 \text{ cm}^{-1}$					
λ	μm		200	400	670
$\Delta S (5-\sigma; 1\text{-hr})$	mJy	Point source	110	130	260
		2.6' map	300	350	700

Note: For the FTS, limiting flux density is inversely proportional to spectral resolution ($\Delta\sigma$). Limiting line flux is independent of spectral resolution (for an unresolved line).

These estimated sensitivity levels are comparable to the figures in the SPIRE proposal.

5. INTERFACE WITH SATELLITE

5.1 IDENTIFICATION AND LABELLING

Each individual instrument unit is allocated two unique identification codes:

- a *project code* which is the normal reference used for routine identification in correspondence and technical descriptive material.
- a *spacecraft code* finalised by the spacecraft contractor in accordance with the computerised configuration control system to be implemented, and used in particular for connector and harness identification purposes. All of these have now been given a working designation anyway as work has progressed. The *project code* shall form part of the spacecraft code. (See IID-A section 5.1)

The project codes allocated to this instrument are:

Project code	Instrument unit	Location	Temperature
HSDPU	Digital Processing Unit	On SVM	Warm
HSFCU	FPU Control Unit	On SVM	Warm
HSDCU	Detector Control Unit	On SVM	Warm
HSJFS	JFETs (Spectrometer)	See section 5.3	Cryogenic
HSJFP	JFETs (Photometer)	See section 5.3	Cryogenic
HSFPU	Focal Plane Unit	See section 5.3	Cryogenic
HSWIH	Warm interconnect harness	See section 5.10	Warm

The HSFCU is a physical unit containing three functions, the HSSCU and the HSMCU meaning the HS Sub-System Control Unit and the HS Mechanisms' Control Unit respectively, plus the HSPSU that provides secondary power to all parts of the Spire DRCU..

[Documentation may refer to a DRCU or Detector Readout and Control Unit. This is no longer a single unit and the term refers collectively to the HSDCU plus the HSFCU.]

There are four groups of harnesses at instrument interface level,

- HSW_{xx},
- HSl_{xx}
- HSS_{xx}
- HSC_{xx}

where xx represents a number.

The HSW_{xx} are Warm harnesses between Warm HS units on the SVM.

HSS_{xx} are the SVM cryoharnesses between the SVM connector brackets and the HS Warm Units.

The HSl_{xx} are intermediate cryoharnesses, which are external to the cryostat, and are situated between the vacuum connectors and the connector bracket on the SVM.

The HSC_{xx} are cryogenic cryoharnesses located inside the cryostat, between the vacuum connectors and the HS Cryogenic units.

The HSIxx, HSSxx and HSCxx are all considered to be "Cryoharness" and are not provided by the Spire instrument.

The two F harnesses (FPU sub-system F harness) between JFETs and FPU (HSFPU-HSJFP and HSFPU-HSJFS) are provided by SPIRE with the instrument units.

"ESA's contractor will also provide any safing plugs needed (TBD, SPIRE to provide a TN) for the cryoharness"

5.2 INTERFACE LOCATIONS

All of the above may be visualised by means of the block diagram, shown in figure 5.2.1 (see RD 8). The Herschel to Herschel-Spire electrical interfaces are in several "planes" shown by dashed blue lines, the categories between each line being labelled along the top. This diagram is for information only, and shall not represent any requirement on the spacecraft.

Note that, to be precise, electrical interfaces are at the connector planes.

5.2.1 MECHANICAL COORDINATE SYSTEM

The unit specific x,y,z origin definitions are shown in the External Configuration Drawings. (see section 5.4)

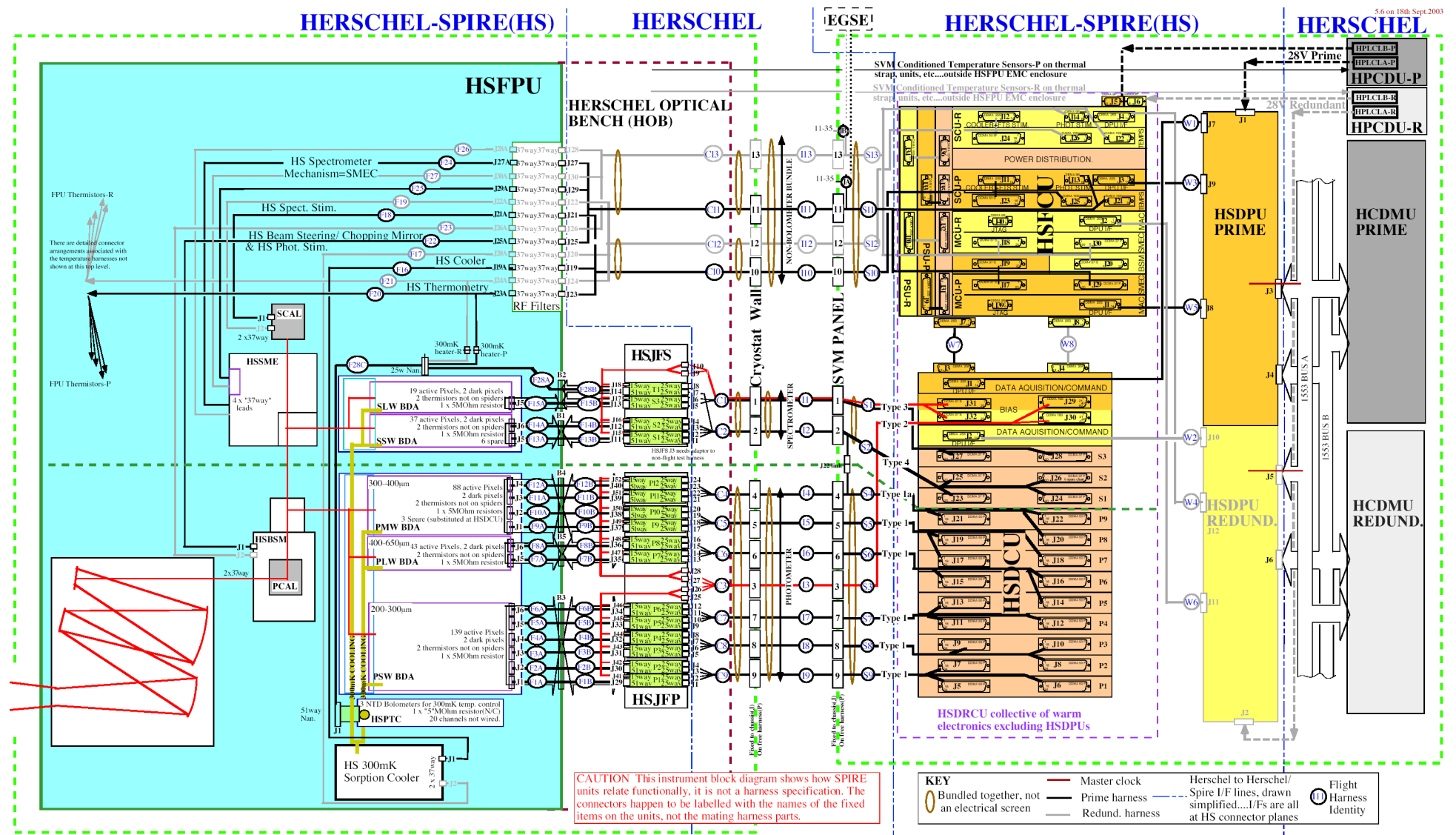

Figure 5.2.1 : Spire Block Diagram - version 5.6

5.3 LOCATION AND ALIGNMENT

Figure 5.3-1 shows the concept of the location of the three Herschel Focal Plane Units (FPUs) for HIFI, PACS and Spire on the Optical Bench (OB) inside the cryostat. The Spire FPU has two nearby JFET racks.

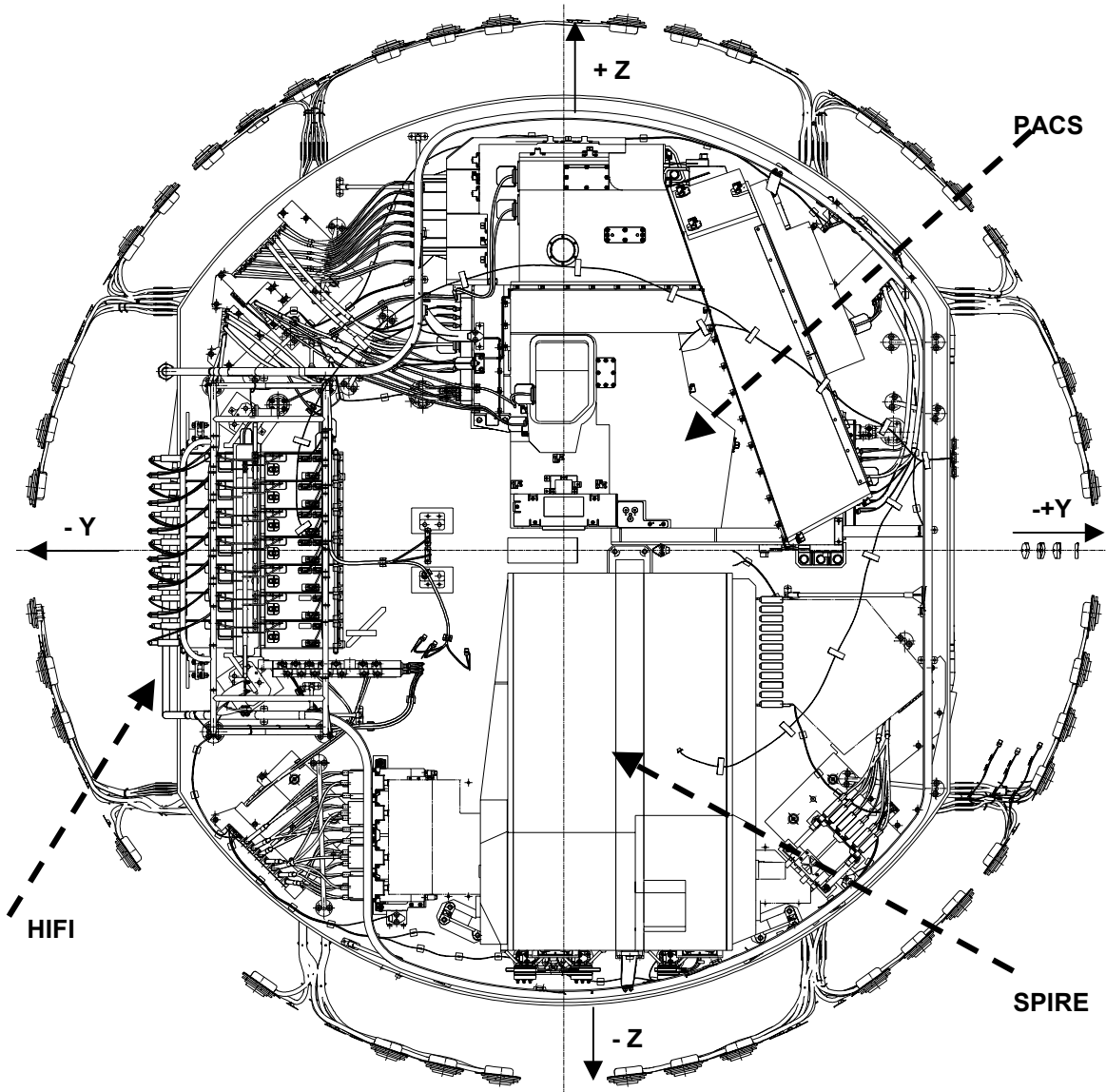

Figure 5.3-1: The Herschel Focal Plane, top view towards -X

5.3.1 Instrument Location

The locations of the Spire units are as listed in section 5.1. Spire has no units supported on the outside of the Herschel cryostat or on the Planck Module. There are no critical alignment requirements on the Spire JFET boxes.

5.3.1.1 Location of units on the SVM

There are no specific requirements for the location of Spire units on the SVM, except that the HSDCU and HSFCU need optimised harness routing towards the Spire quadrant of cryostat 128 way connectors. The length of the instrument provided harness between the HSDCU and the HSFCU is critical. As a goal, the location of these two units on the SVM should enable this length to be kept below 0.8m.

The picture here under shows the Spire specific SVM panel

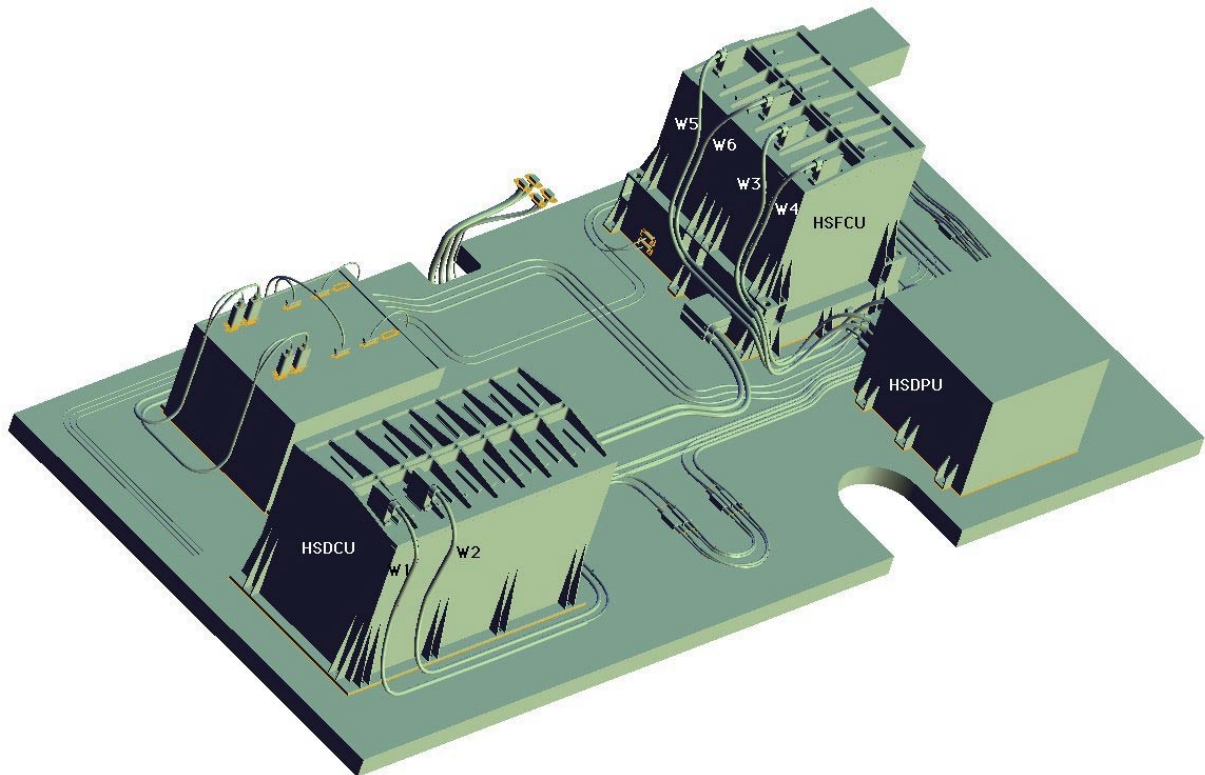

5.3.2 Instrument Alignment on the HOB

Spire has no critical alignment and/or alignment stability requirements except for those of the HSFPU.

The HSFPU has an externally viewable alignment cube as shown on its ICD. Both the cube's angular alignment and the position of the HSFPU box' feet w.r.t. its internal optics will have been established at instrument level to a defined tolerance before delivery to ESA.

The mechanical process of mounting Spire on the HOB so that it is aligned to the Herschel telescope (when both are at operating temperature) is worked through in AD7. This defines an error budget for how well the alignment has to be achieved, as well as how stable it then has to remain.

5.4 EXTERNAL CONFIGURATION DRAWINGS

These are included for readability only.

The fully configured detailed interface drawings are provided in Annex 1.

5.4.1 HSFPU

An overview of the HSFPU is provided below in Figure 5.4-1. More detailed drawings of the SPIRE focal plane and JFET units, showing their relationship to the Herschel focal plane, the cryostat radiation shield and the diameter of the HOB, can be found in Annex 1.

NOTE: -

1. ALL DIMENSIONS AT ROOM TEMPERATURE
2. J-FET BOXES NOT SHOWN ON THIS SHEET

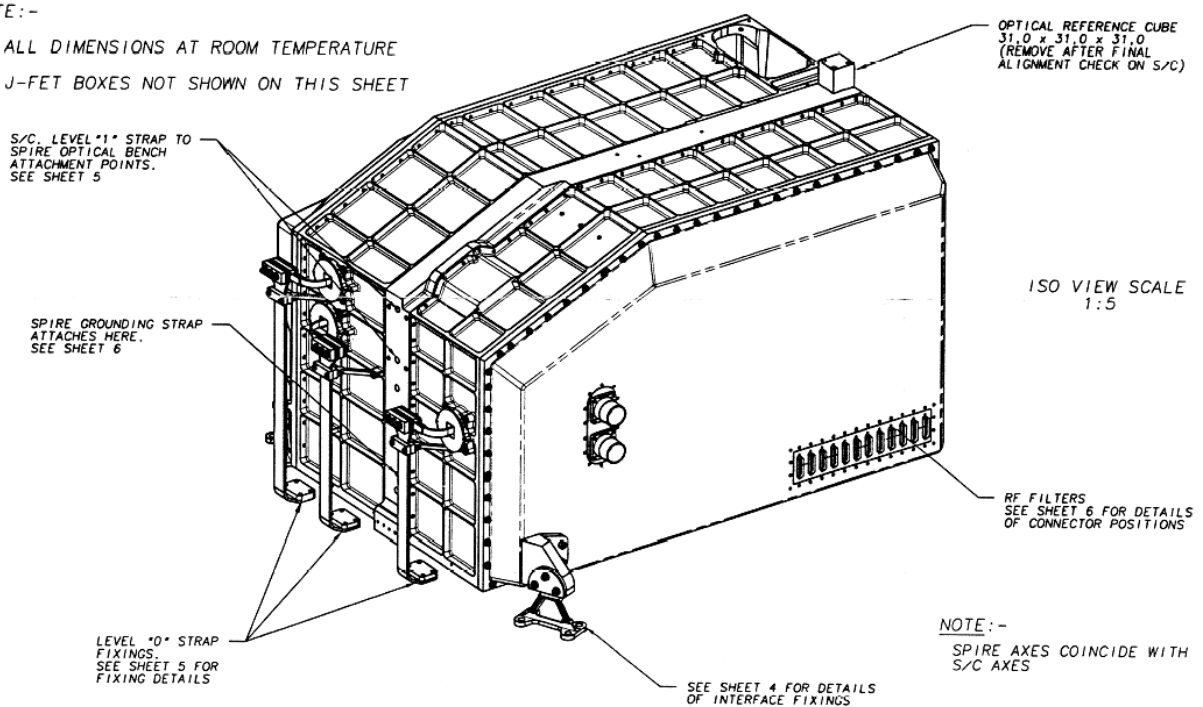

Note: figure extracted from Interface Drawing, Issue 17, Sheet1

Figure 5.4-1 : HSFPU overall view

5.4.2 HSJFS

Figure 5.4-3 provides an isometric view of the Spire Spectrometer JFET rack. More detailed drawings can be found in Annex 1.

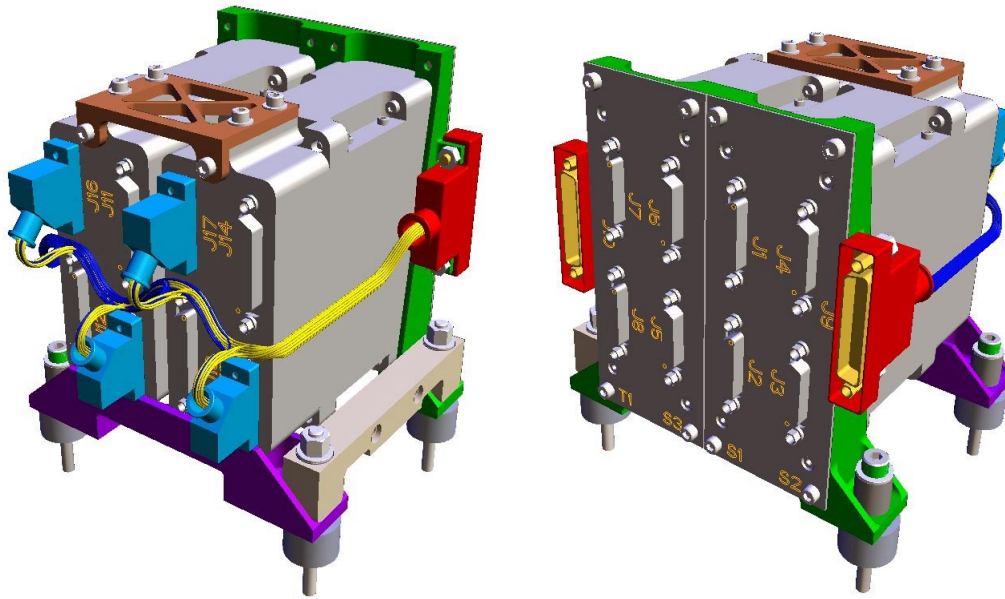

Figure 5.4-3 : SPIRE Spectrometer JFET rack external configuration

5.4.3 HSJFP

Figure 5.4-4 provides an isometric view of the Spire Photometer JFET rack. More detailed drawings can be found in Annex 1.

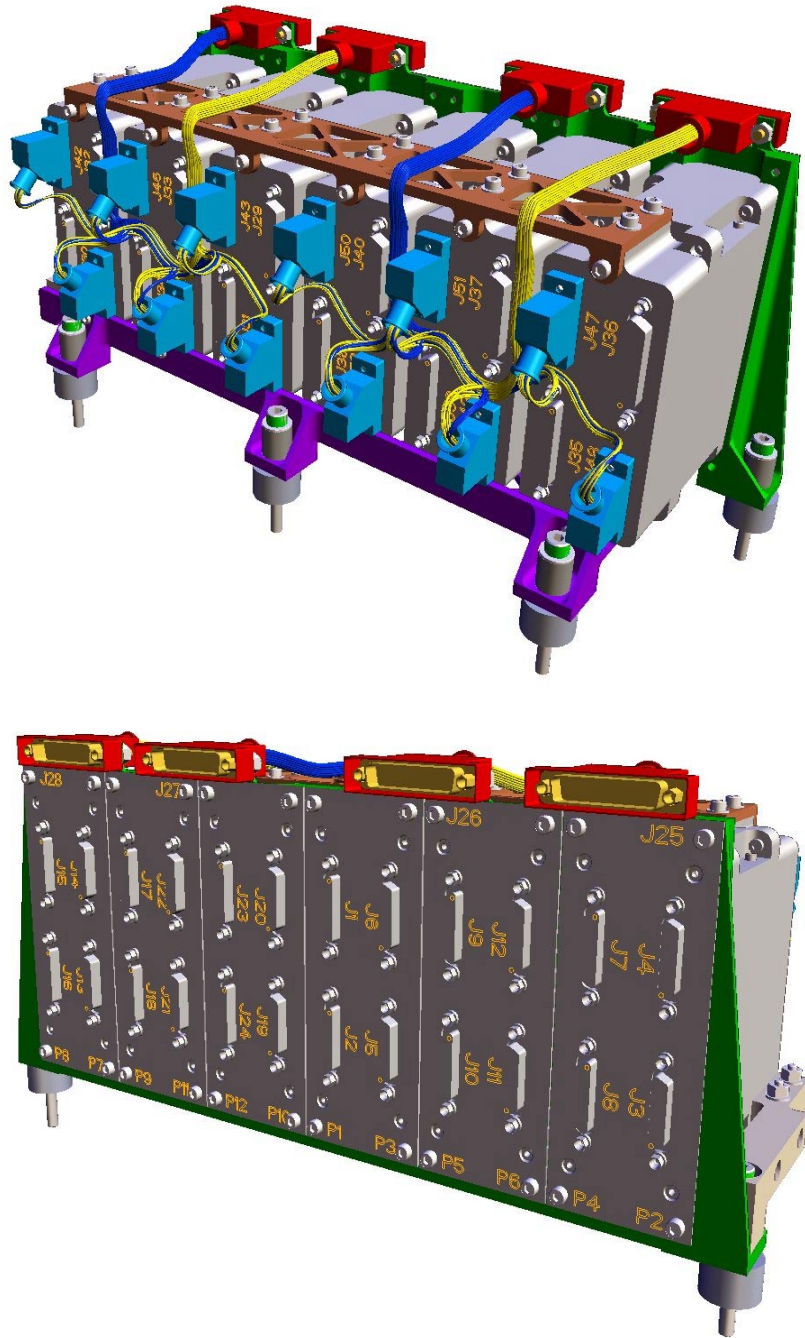

Figure 5.4-4 : SPIRE Photometer JFET rack external configuration

5.4.4 SVM Mounted Units.

Drawings of the layout of the SPIRE Warm Units on the SVM are provided in the corresponding section of the IIDA.

The following sub-sections provide an overview of the warm units, whereas detailed interface drawings can be found in Annex 1.

5.4.4.1 HSDPU

Figure 5.4-6 shows an isometric view of the Spire Digital Processing Unit. More detailed drawings can be found in Annex 1.

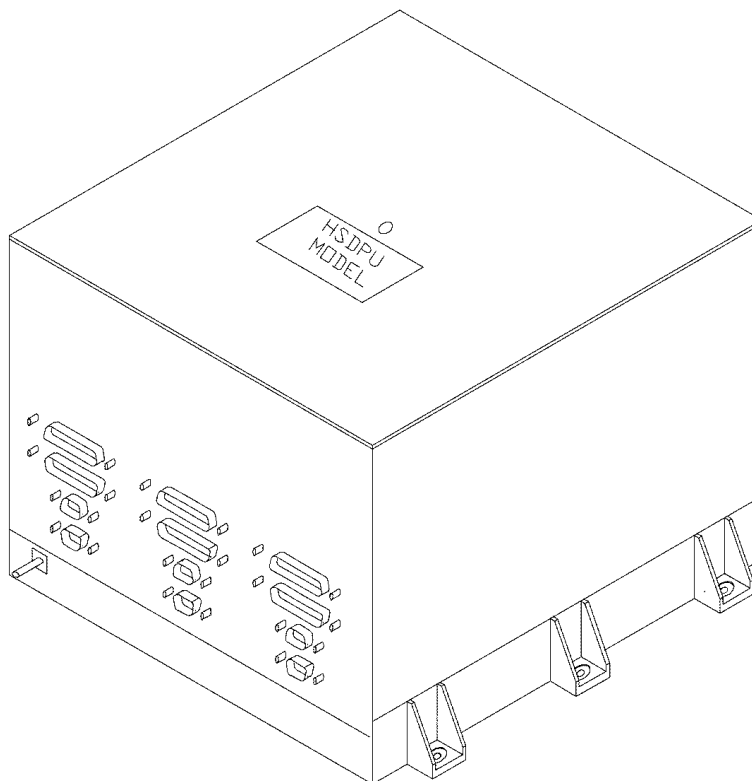

Figure 5.4-6 Isometric view of the DPU

5.4.4.2 HSDCU

Figure 5.4-7 shows an isometric view of the Spire Detector Control Unit. More detailed drawings can be found in Annex 1.

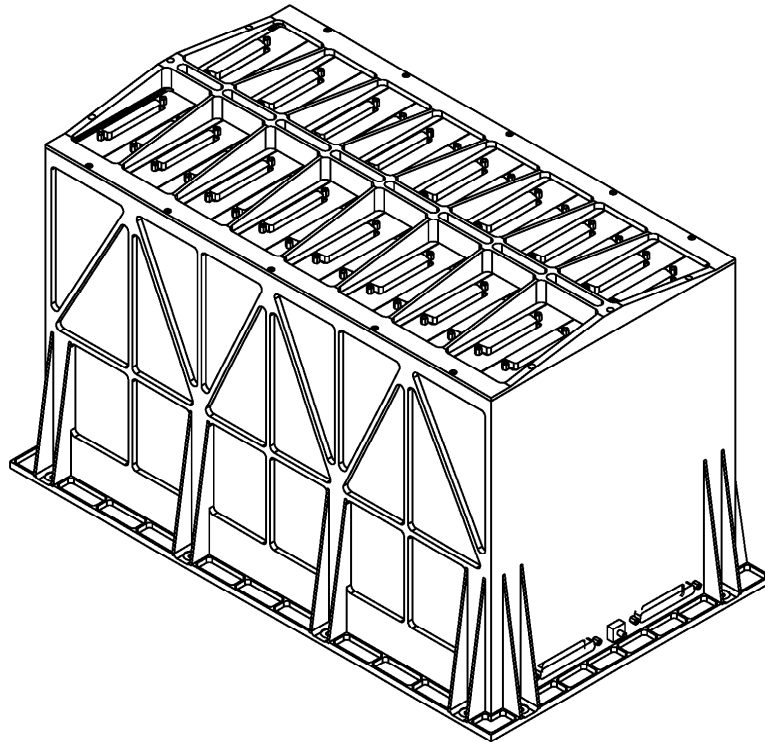

Figure 5.4-7 : HSDCU external configuration

5.4.4.3 HSFCU

Figure 5.4-8 shows an isometric view of the Spire FPU Control Unit.

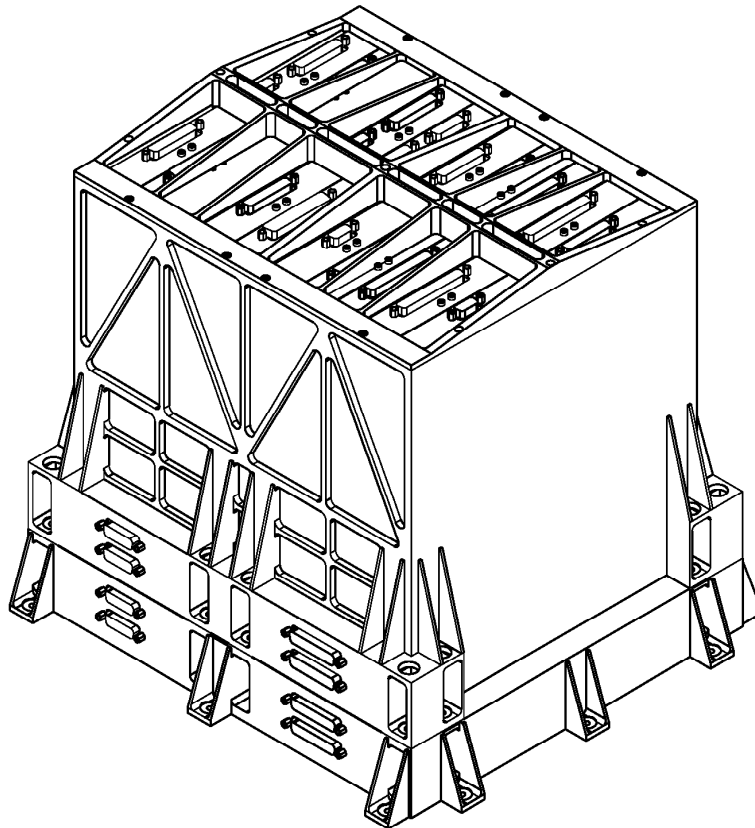

Figure 5.4-8 : HSFCU external configuration

Note: figure and ICD/drawing to be updated (contact area and M5 screws), a CR is to be issued by SPIRE

5.5 SIZES AND MASS PROPERTIES

Project Code	Instrument Unit	Dimenions (mm) including feet	Nominal Mass without margins (kg)	Allocated Mass (kg)
HSFPU	HS Focal Plane Unit (*)	Non-rectangular	44.81 (**)	47.2
HSJFP	HS JFET Rack Photometer	124.6 x 118.2 x 274.5	2.51	2.8
HSJFS	HS JFET Rack Spectrometer	114.2 x 114 x 112.5	0.89	1.0
		Total SPIRE OB Units	48.21	51.0
HSFCU	HS FPU Control Unit	325 x 370 x 335	15.28	15.0
HSDCU	HS Detector Control Unit	490 x 285 x 305	15.68	15.5
HSDPU	HS Digital Processing Unit	274 x 274 x 194	7.18	7.0
HSW1-8	HS Warm Inter-unit Harness	To Alenia layout	1.5	1.5
		Total SPIRE SVM Units	39.64	39.0
		SPIRE Instrument Total	87.84	90.0

(*): HSFPU includes attached flying leads and any FPU thermal strap supports.

(**):includes 32.07Kg Nominal and 34.77Kg Allocation for Structure mass elements, see lss 1.4 of RD1 as DDR

The drawings for all these items are in annex 1, in SPIRE-RAL-DWG-001409 issue 6

Dimensions are given in the order XxYxZ, and XYZ axis are defined on each unit drawing in annex 1.

Dimensions including mounting feet, excluding connectors.

5.6 MECHANICAL INTERFACES

Note: Electrical and thermal characteristics conferred by these mechanical interfaces are covered in the appropriate sections, not here.

5.6.1 *Inside cryostat*

The Focal Plane Unit, the HSFPU, has 3 supporting feet to the Optical Bench. The details of this mechanical interface will be such as to allow the unit alignment and alignment-stability requirements to be fulfilled.

The Spire JFET racks will also mechanically interface directly to the Optical Bench.

5.6.1.1 Microvibrations

Spire's mechanisms (SMEC and BSM) are sensitive to microvibrations between 0.03 Hz and 300 Hz, with the potential effect of displacing the SMEC suspended mirrors from their optical positions. The bolometers, as they are accommodated, probably have a similar susceptibility to HOB-driven microvibrations. This is potentially due to harness flexure /capacitance changes, rather than to movements of the detector elements themselves.

Spire needs knowledge of the level of the microvibration-induced forces on the HSFPU at its HOB interface, in order to ensure they can be mitigated. The expected levels of input acceleration are to be provided by ESA/Alcatel, over the frequency range between 30 Hz and 300 Hz.

5.6.1.2 Thermal Straps

SPIRE requires the following thermal straps:

- 3 Level-0 thermal straps
- 2 Level-1 thermal straps
- 2 Level-3 thermal straps

The mechanical I/F geometry, fixing torque, mechanical load cases, etc. for each of these straps is as baselined in the IID-A. See section 5.4 for positions on Spire and section 5.7 for more details.

The HERSCHEL to Spire interfaces for the L0 straps are at three standardised points just above the HOB plate. For information, inside SPIRE, these thermal straps will be steadied by non-metallic supports on the outside of the FPU, designed to minimise the forces the straps can apply to thermal lead-throughs, but not be Ohmic shorts. Separate supports are needed to minimise cross-coupling between the two sorption cooler straps.

SPIRE JFET L3 I/F with electrical insulation The SPIRE JFET L3 thermal strap interface shall be implemented as shown in the figure below.

The shape of the L3 thermal strap shall have a T-shaped end bracket (40mm x 12mm). The requirement for the two L3 straps are as follows:

- Bolt hole tolerance $\varnothing 6.00-6.05\text{mm}$
- Bolt spacing 25mm +/-0.1 according to AD3-1
- Gold plated on both I/F sides > 10microns
- Flatness <0.05, roughness <0.4microns

SPIRE will provide all needed clamping and fixation parts, which will be equipped by SPIRE with an electrical insulation. The H-EPLM Contractor shall supply a T-shaped end-bracket of the flexible link for each JFET rack (i.e. 2-JFET and 6-JFET) as shown below. SPIRE will provide the clamp block with insulated bushes and Kapton on the JFET rack I/F. The impact of the Kapton tape at the JFET I/F belongs to the SPIRE thermal budget. The arrangement is shown in the figure 5.6-1 below.

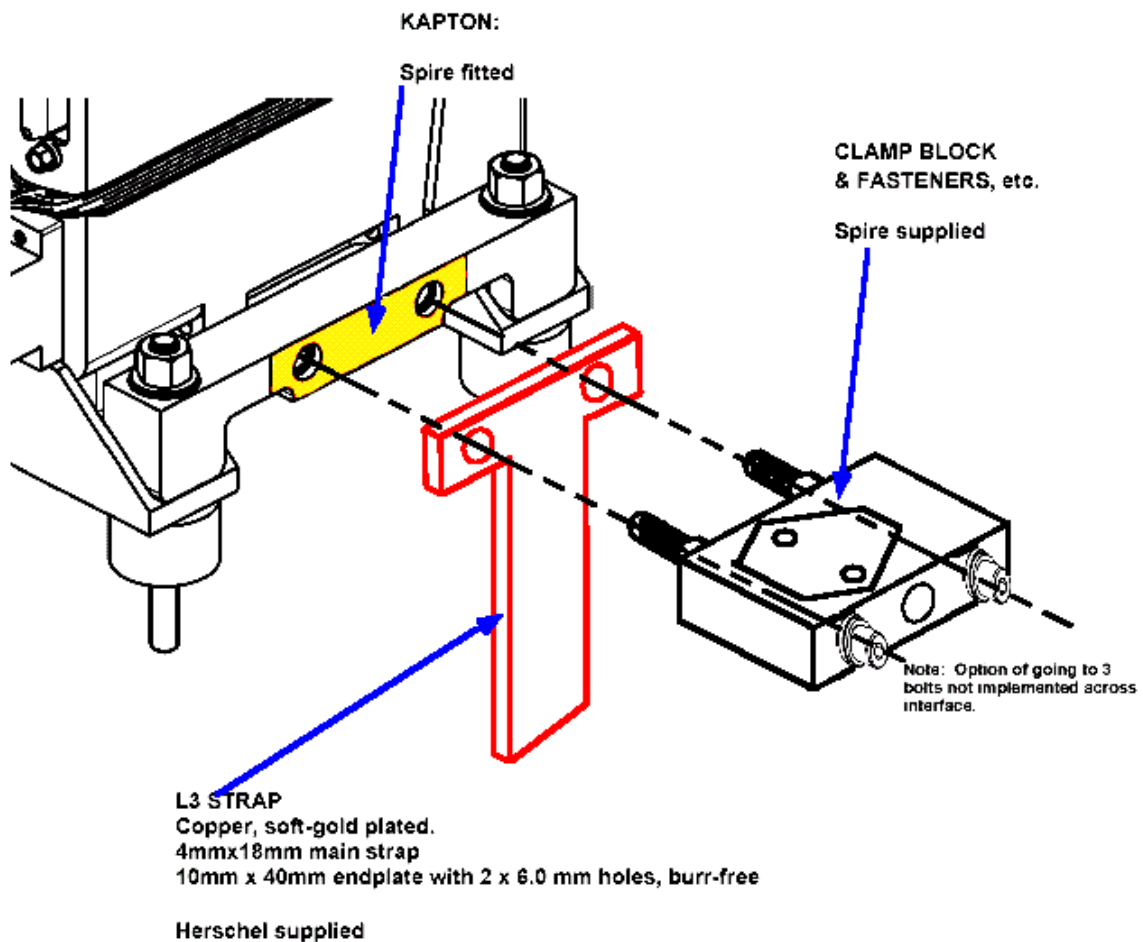

Figure 5.6-1: SPIRE JFET L3 interface including electrical insulation

SPIRE L1 electrical insulation I/F

The electrical insulation of the L1 thermal straps shall be implemented between the SPIRE L1 Thermal Straps and the Optical Bench He ventline.

- The H-EPLM contractor shall provide:
 - A single pressure plate with 4 holes diameter 6.0mm to 6.05mm
 - 4 holes diameter 6.0mm to 6.05mm in the flexible end bracket
- SPIRE/RAL will provide the following parts to incorporate an electrical insulation:
 - 75micron Kapton tape with adhesive layer to be attached on the flexible end bracket or on the pipe.
 - 5.90-5.95 mm bolt bush bolt for electrical isolation of bolt. Required bush length will be defined after freeze of SEN/AIRL bracket design.
 - Impact of Kapton tape belongs to the SPIRE thermal budget.

The concept is shown in the figure 5.6-2 below.

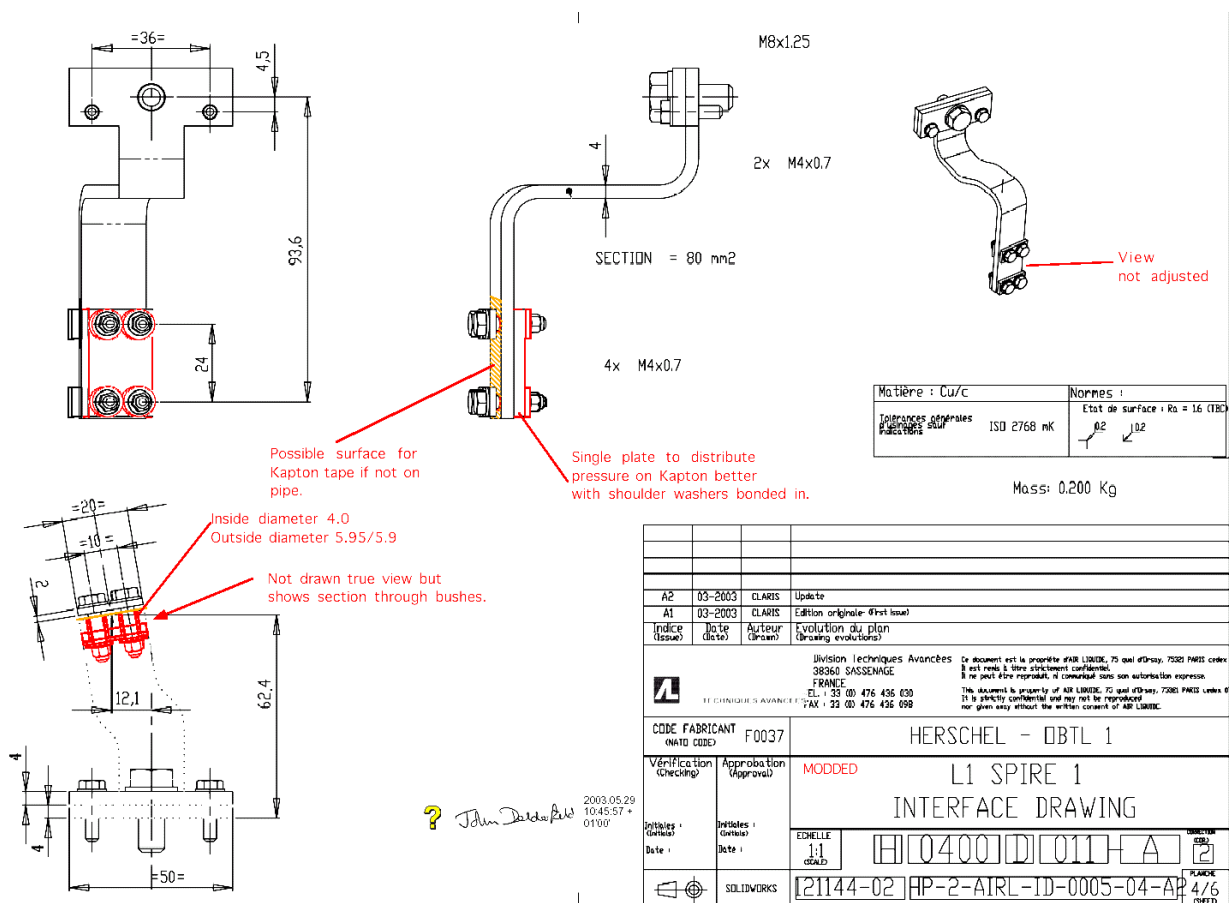

Figure 5.6-2: Electrical Insulation of SPIRE L1 thermal strap interface

5.6.2 Outside Cryostat

NA

5.6.3 On SVM

The three units mounted on the SVM will each have attachment points for fixation to the equipment platform, as shown in their External Configuration Drawings. Interface flatnesses, fasteners and tightening torques are all defined on these drawings.

The Spire warm harness will be attached to the SVM via TBD devices provided by Industry.

5.6.4 On Planck Payload Module

NA

5.6.5 Cooler valves and piping

NA

5.7 THERMAL INTERFACES

The cryogenic interfaces are the most important category of interfaces for Spire 's success, and the most complicated. They would provide the most gain to science performance from being improved.

The SPIRE reduced TMM (issue 2.3) is given in annex 2

SPIRE heat flow diagram is given by the figure here under:

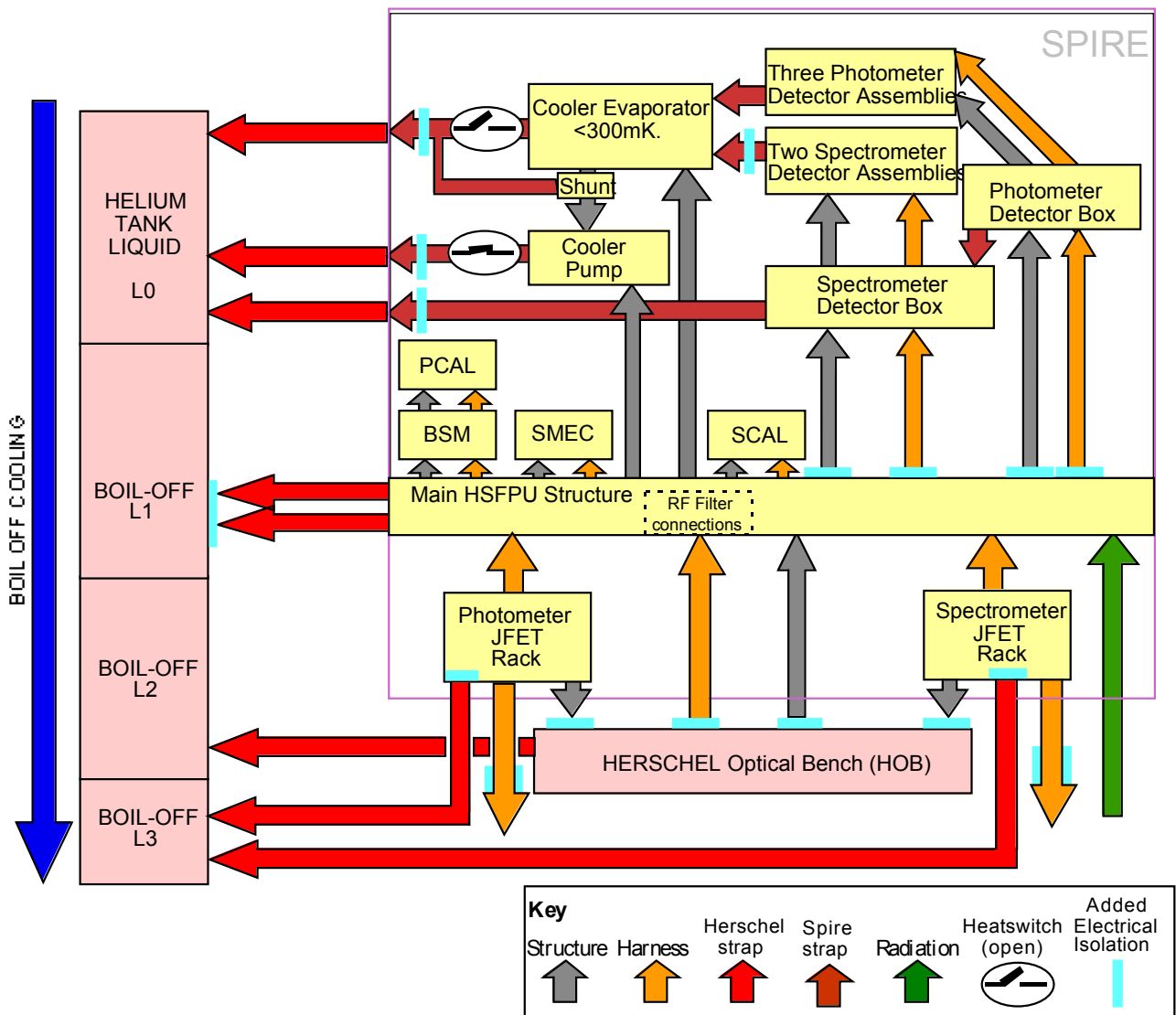

Figure 5.7-1: SPIRE heat flow diagram

5.7.1 Inside the cryostat

Note: all this section 5.7.1 is in accordance with minutes of "LO agreement meeting H-P-ASP-MN-3961" and "Spire IF meeting H-P-ASP-MN-3967", which take precedence on "SPIRE IIDB Convergence meeting H-P-ASP-MN-3513" and "SPIRE IIDB Telecon H-P-ASP-MN-3668".

5.7.1.1 Description of the thermal interfaces

Spire uses 4 thermal stages to run 300mK detectors inside a ⁴HEII cryostat,. These link into levels provided by the Herschel cryostat. An overview of the Spire system is as follows, drawn with the heat switches associated with its 300mK cooler set as for an observing mode.

Electrical insulation is not shown here for electrical purposes but rather because where high thermal conduction is needed it adds to the design challenge. The radiative loads on Spire, shown in green, potentially come from warm baffles "seen" off-axis up the optical beam aperture. The arrow for external harness loads on the JFETs is not joined to anything specific as this depends on design decisions taken by Astrium.

Spire has two detector optical box structures, one housing the photometer detectors and one the spectrometer's. They mount on thermally isolating mounts inside the HSFPU and, to minimise the heat leak to the 300mK detectors themselves, link to the lowest available temperature, the LO cryostat liquid sink. The spectrometer box has an external LO interface and the photometer is then linked from it internally to the HSFPU, so together they only require one external I/F strap to LO.

As shown above in figure 5.7-1, there are two other LO interfaces associated with the 300mK sorption cooler which is described below.

Not shown in the above overview are the small thermal loads on the Spire side of the I/F on the three LO straps, due to their necessary mechanical support to the FPU.

The main HSFPU mountings to the HOB are also designed to be thermally isolating, so that the HSFPU can run at L1 whilst the HOB itself is at L2. The HOB tends to warm the HSFPU, which is why the structure and harness heat flow arrows are as shown.

When operational, JFET racks have a comparatively high dissipation. Fortunately, within reason, it is actually advantageous to run them a little warm. They therefore attach further up the boil-off line sequence to L3. Note that Spire plans to only power one rack at a time, either spectrometer or photometer and, depending on which is the more thermally demanding mode to operate in, their order on the L3 pipe is significant. Due to gas flow, the earlier can heat the later (with a heat path back into the FPU) but not visa versa.

To provide the required overall thermal balance boundary, the cryostat's inner instrument shield forms an enclosure at level 2, and the effective temperature seen from the surface of the HSFPU, integrated over an outward hemisphere, needs to be well specified.

5.7.1.2 Description of Operation and Interfaces for the 3He Cooler

The Sorption Cooler interfaces and operation are described in Annex 4

5.7.1.3 Thermal requirements

Two major thermal requirements for SPIRE are its sorption minimum cooler cycle time of 48h, and its detector temperature of < 310mK.

The table below shows the required operating temperatures and design heat flows at the thermal interfaces of the instrument unit with the cryostat or parts thereof :

In-Orbit thermal requirements				
SPIRE FPU thermal I/F		Max I/F Temp @ Max Heat Load		Cooler State
		Requirement	Goal	
L0	Detector Box	2 K @ 4 mW	1.71 K @ 1 mW	Operating
	Cooler Pump	2 K @ 2 mW	2 K @ 2 mW	Operating
		10 K @ 500 mW peak	10 K @ 500 mW peak	Recycling
	Cooler Evaporator	1.85 K @ 15 mW	1.75 K @ 15 mW	Recycling
L1		5.5 K @ 15 mW	3.7 K @ 13 mW	Operating
L2	Optical bench / FPU legs	12 K @ no load	8 K @ no load	Operating
L3	HSJFP (JFET Photometer)	15 K @ 50 mW	15 K @ 50 mW	-
	HSJFS (JFET Spectrometer)	15 K @ 25 mW	15 K @ 25 mW	-
-	Instrument shield (eq. Radiative temperature)	16 K @ -	16 K @ -	-

Notes:

- Assuming a He² tank temperature of 1.7 K
- Sorption Cooler Recycling phase is composed of 2 phases in sequence, see Annex 4 for information

Table 5.7-1: In-Orbit thermal requirements

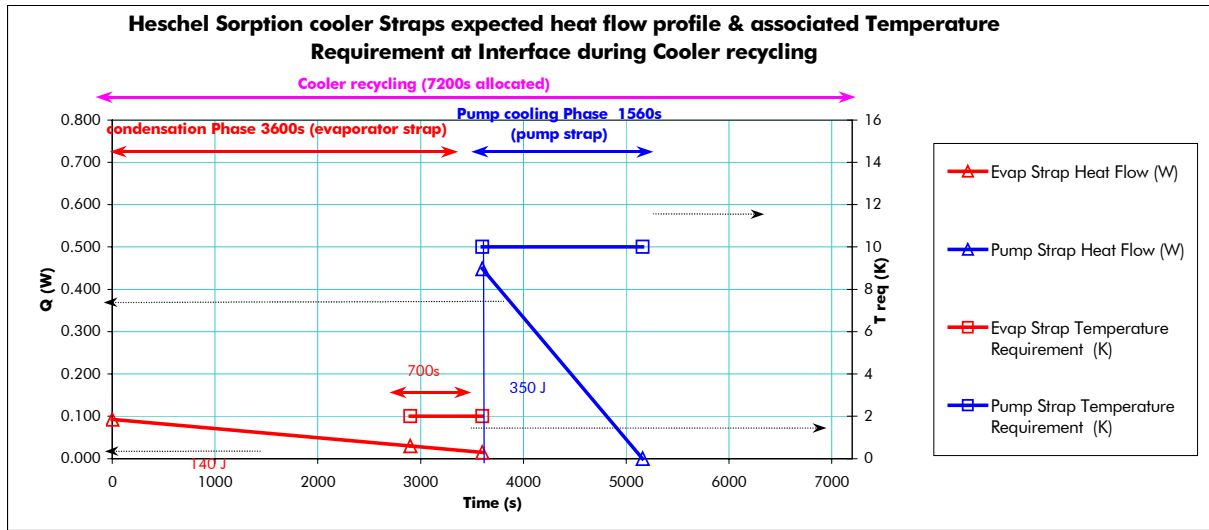

Figure 5.7.2: Expected heat profiles on evaporator and Pump strap, during recycling

SPIRE FPU thermal I/F		Ground							
		Operations FM (IMT/IST)		Operations EQM		Cooler recycling		non operating	
		Max I/F Temp	Max. Heat load	Max I/F Temp	Max. Heat load	Max I/F Temp	Max. Heat load	Max continuous Temp	Bake out Temp (72h max)
L0	SPIRE SM Detector enclosure (814)	Same as in orbit, as far as possible						60.0 °C	80 °C
	SPIRE Cooler Pump strap (node 815)	All values TBD (on going open actions)						60.0 °C	80 °C
	SPIRE Cooler Evaporator strap (node 816)							60.0 °C	80 °C
L1	SPIRE L1 (two straps) (node 800)							60.0 °C	80 °C
L2	SPIRE L2 (Optical bench / FPU legs)								80 °C
L3	SPIRE L3 HSJFP, HSJFS								80 °C

Table 5.7-2: On ground thermal requirements

5.7.1.4 Worst case temperatures

The cryogenic units must withstand the full thermal environment given in the IIDA, including repeated max. 72hr. 80°C bake-outs and indefinite 60°C soak.

5.7.2 Outside the Cryostat

NA

5.7.3 On the SVM

The table below shows the required operating temperatures at the interface of the instrument unit with a mounting platform or parts thereof:

Project code	Operating		Start-up	Switch-off	Non-operating	
	Min. °C	Max. °C	°C	°C	Min. °C	Max. °C
HSDPU	- 15	+ 45	- 30	+ 50	- 35	+ 60
HSFCU	- 15	+ 45	- 30	+ 50	- 35	+ 60
HSDCU	- 15	+ 45	- 30	+ 50	- 35	+ 60

Note:

- Acceptance temperature range is from 5 °C below min. to 5 °C above max. operating temp.
- Qualification temperature range is from 10 °C below min. to 10 °C above max. operating temp.
- During nominal operation in-flight, the SVM units will not move at more than 3K/hour.
- Spire units will be thermally joined over their base mounting I/Fs to the panel skins which will help stabilise the temperature of un-powered sections and absorb dissipated heat when powered by conduction. If it is found that other arrangements are needed, such as low temperature limit thermostated heaters, these shall be external and Herschel furnished. If details are determined on time-scales that can be accommodated, Spire will build in minimal necessary mounting arrangements for such systems, TBC.

5.7.4 On the Planck Payload Module

NA

5.7.5 Temperature channels

5.7.5.1 Instrument Temperature Sensors

For information the table below shows the measurement of instrument cryogenic temperatures. These data are available in DPU science packets (unless otherwise indicated) via whichever is powered of the prime and redundant sides of the Spire electronics. They may also be included in some housekeeping packets.

Each Prime/Redundant side uses different, electrically isolated sensors and will therefore have subtly differing electrical to temperature calibrations. Note that the accuracy columns that follow refer to the performance of the complete system including cryoharness and electronics, not the sensors alone. "Resolutions" and "Accuracy" will need to be further defined as they are actually temperature dependant.

Cernox sensors type CX-1030 are used for all HSFPU SPIRE conditioned housekeeping temperatures. The below table is consistent with RD19.

Location IN HSFPU	Acronym	Sensor Type	Temp. Range	Resol.	Acc.
PSW BDA_1	T_PSW_1	NTD Ge Thermistor*	0.2 K>5 K	0.5mK	2mK
PSW BDA_2	T_PSW_2	NTD Ge Thermistor	0.2 K>5 K	0.5mK	2mK
PMW BDA_1	T_PMW_1	NTD Ge Thermistor	0.2 K>5 K	0.5mK	2mK
PMW BDA_2	T_PMW_2	NTD Ge Thermistor	0.2 K>5 K	0.5mK	2mK
PLW BDA_1	T_PLW_1	NTD Ge Thermistor	0.2 K>5 K	0.5mK	2mK
PLW BDA_2	T_PLW_2	NTD Ge Thermistor	0.2 K>5 K	0.5mK	2mK
SSW BDA_1	T_SSW_1	NTD Ge Thermistor	0.2 K>5 K	0.5mK	2mK
SSW BDA_2	T_SSW_2	NTD Ge Thermistor	0.2 K>5 K	0.5mK	2mK
SLW BDA_1	T_SLW_1	NTD Ge Thermistor	0.2 K>5 K	0.5mK	2mK
SLW BDA_2	T_SLW_2	NTD Ge Thermistor	0.2 K>5 K	0.5mK	2mK
300mK Plumbing Cntrl_1	PTC_Ch1	NTD Ge Thermistor	0.2 K>5 K	0.05mK	0.2mK
300mK Plumbing Cntrl_2	PTC_Ch2	NTD Ge Thermistor	0.2 K>5 K	0.05mK	0.2mK
300mK Plumbing Cntrl_3	PTC_Ch3	NTD Ge Thermistor	0.2 K>5 K	0.05mK	0.2mK
HSFPU EMC filters	EMCFIL	CX-1030	3K>100K	25mK	50mK
Spectrometer 2K box	T_SLO	CX-1030	1K>10K	2mK	2mK
Photometer 2K box	T_PLO	CX-1030	1K>10K	2mK	2mK
M3,5,7 Optical SubBench	T_SUB	CX-1030	3K>100K	25mK	50mK
HSFPU Input Baffle	T_BAF	CX-1030	3K>80K	5mK	5mK
BSM/SOB I/F	T_BSMS	CX-1030	3K>80K	5mK	5mK
HS Spect. Stimulus Flange	T_SCST	CX-1030	1K>50K	10mK	10mK
Sorption Pump	T_CPHP	CX-1030	1K>50 K	10mK	10mK
Evaporator	T_CEV	CX-1030	0.2 K>5 K	1mK	1mK
Sorption Pump Heat Switch	T_CPHS	CX-1030	1K>50K	10mK	10mK
Evaporator Heat Switch	T_CEHS	CX-1030	1K>50K	10mK	10mK
Thermal Shunt	T_CSHT	CX-1030	0.2 K>5 K	1mK	1mK
HS Spect. Stim 4%	T_SCL4	CX-1030	3K>80K	5mK	5mK
HS Spect. Stim 2%	T_SCL2	CX-1030	3K>80K	5mK	5mK
BSM	T_BSMM	CX-1030	3K>20K	10mK	10mK
SMEC	T_FTSM	CX-1030	3K>20K	10mK	10mK
SMEC/SOB I/F	T_FTSS	CX-1030	3K>100K	25mK	50mK

*NTD Ge Thermistor is equivalent to a detector element, but it is not mounted on an isolating web.

5.7.5.2 Shutter Temperature Sensors

The SPIRE shutter has been removed. Temperature sensors are therefore not required

5.7.5.3 Satellite Temperature sensors

In addition to the Spire conditioned temperature channels, Spire requires that Herschel itself shall monitor the temperatures of certain locations on the cryostat and SVM. These are given in the table below.

Position	Type (1)	Name (1)	CCU Measurement		EGSE Measurement	
			Range	Accuracy	Range	Accuracy
On Instrument Shield, close to SPIRE	C100	T213	3.0K - 20.0K	± 0.1K	3.0K - 20.0K	± 0.1K
L0; Cooling Strap 5; to "SPIRE SM Detector enclosure"	C100	T225	1.6K - 2.0K	± < 0.001K	1.6K - 2.0K	± < 0.001K
L0; Cooling Strap 6; to "SPIRE Cooler Pump HS"	C100	T226	2.0K - 10.0K	± 0.01K	2.0K - 10.0K	± 0.01K
L0; Cooling Strap 7; to "SPIRE Cooler Evaporator HS"	C100	T227	1.5K - 2.2K	± < 0.01K	1.5K - 2.2K	± < 0.01K
L1; on Ventline upstream strap 4 to "SPIRE Optical Bench"	C100	T235	2.0K - 10.0K	± 0.01K	2.0K - 10.0K	± 0.01K
L1; on Ventline downstream strap 4 to "SPIRE Optical Bench"	C100	T236	2.0K - 10.0K	± 0.01K	2.0K - 10.0K	± 0.01K
L3; on Ventline to JFET-Phot	C100	T246	3.0K - 20.0K	± 0.1K	3.0K - 20.0K	± 0.1K
L3; on Ventline to JFET-Spec	C100	T247	3.0K - 20.0K	± 0.1K	3.0K - 20.0K	± 0.1K
L1; on Strap 4 on SPIRE FPU side	C100	T248	2.0K - 10.0K	± 0.01K	2.0K - 10.0K	± 0.01K
On Spire JFET-Spec (Pos on Structure or L3 strap)	PT1000	T249			13K - 370K	± 1K
On Spire JFET-Spec (Pos on Structure or L3 strap)	C100	T250	3.0K - 20.0K	± 0.1K	3.0K - 20.0K	± 0.1K
On Spire JFET-Phot (Pos on Structure or L3 strap)	PT1000	T251			13K - 370K	± 1K
On Spire JFET-Phot (Pos on Structure or L3 strap)	C100	T252	3.0K - 20.0K	± 0.1K	3.0K - 20.0K	± 0.1K
OB Plate near SPIRE foot (center)	PT1000	T253			13K - 370K	± 1K
OB Plate near SPIRE foot (center)	C100	T254	3.0K - 20.0K	± 0.1K	3.0K - 20.0K	± 0.1K
OB Plate near SPIRE foot (-z+y)	PT1000	T255			13K - 370K	± 1K
OB Plate near SPIRE foot (-z+y)	C100	T256	3.0K - 20.0K	± 0.1K	3.0K - 20.0K	± 0.1K
OB Plate near SPIRE foot (-y-z)	C100	T258	3.0K - 20.0K	± 0.1K	3.0K - 20.0K	± 0.1K

(1): Type and name for information only

Note : One temperature sensor (T257) has been removed.

The SPIRE reduced TMM (issue 2.3) is in annex 2

* Lower values for resolution and accuracy apply at bottom end of range, higher when hot and the absolute value of the requirement is much less stringent. The temperature of an item should be determined (accuracy+ resolution errors) to 2% of its absolute value in Kelvin, TBC

The precise number and location of these sensors shall be confirmed after thermal modelling.

Herschel shall check temperatures are within range, and for instance not empower SVM units outside of their rated operating ranges.

5.8 OPTICAL INTERFACES

The cryostat and baffle structures shall be compatible with the SPIRE beam.

5.8.1 Straylight

The instrument straylight model and its conclusions related to alignment etc. are described in RD-15.

The dimensions of the Spire optical beam stayout envelopes are defined in the HSFPU ICD annexed to the IID-B. These are simplified inclusive shapes, detailed ones can be found in RD-20

For information, Figure 5.8-1 illustrates the SPIRE optical beam envelope viewed as it passes out of the HSFPU, showing the contributions from the photometer and the spectrometer. The differing beams result from the extremes of the BSM's jiggle and chop displacements. The beam envelope formed is the geometric optical beam passing through the Spire cold stop. The 6mm clearance around the beam is the allowance required for beam diffraction.

The figure 5.8-1 here under takes into account the removing of SPIRE shutter

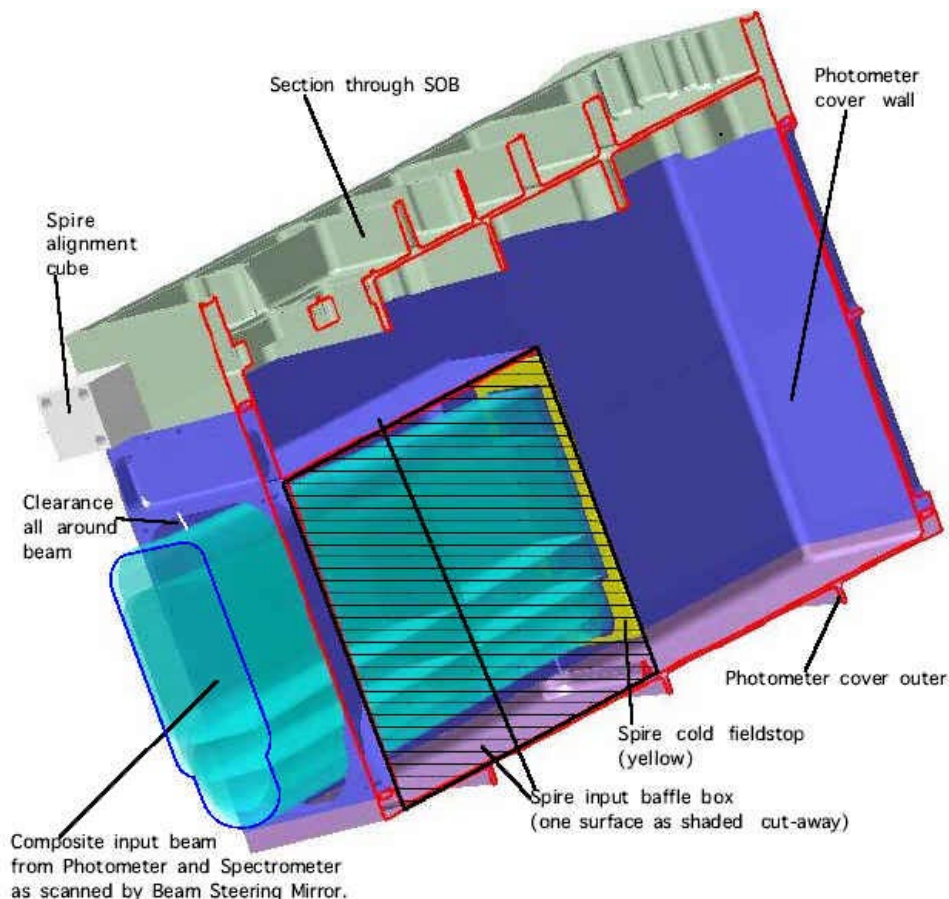

Figure 5.8-1 Spire optical beam envelope as it leaves the HSFPU

The spectrometer's almost circular used beams are the farther from HERSCHEL field centre, and lie to the side of the semi-rectangular beams of the photometer. FOV switching is not used within SPIRE to boresight the photometer and the spectrometer; both are illuminated simultaneously by the HERSCHEL telescope.

5.9 POWER

The thermal design and thermal model is still under evaluation at system level, with industry and ESA project. The values given in 5.9.1 reflect the current known status.

5.9.1 Power inside the cryostat

The SPIRE components which dissipate power inside the cryostat are described in the Table below. It should be noted that the individual component dissipations vary according to the operational mode of the instrument, as described in section 5.9.5.

Component	Dissipation. at component level (mW)
Photometer Cal	0.033
Spectrometer Cal	1.5
300 mK Cooler *	1.8
BSM / Photometry	3
BSM / Spectroscopy	0.2
SMEC / Photometry	0
SMEC / Spectroscopy	3.2
JFETS / Photometry	42
JFETS / Spectrometry	14

* Recycling is a special case, see section 5.7 and Annex 4.

Note: these values are updated (cf SPIRE ECR 63 draft) from thermal model 2.3, and will be included in model version 2.5.

5.9.2 Power outside the Cryostat

NA

5.9.3 Power on the SVM

The following table shows the heat dissipation (in Watts) of the warm electronic units mounted on the SVM. Note that the power passed through to the Cryoharness and the HS FPU is negligible, such that the dissipation values given here are the same as those corresponding to the unit power loads on the bus (Section 5.9.6.1) :

Project Code	Instrument Unit	Dissipation	Comment
HSDPU	HS Digital Processing Unit	15.3 W	
HSFCU	HS FPU Control Unit	42.9 W	Includes power cond. losses
HSDCU	HS Detector Control Unit	37.0 W	Lower in spectrometer Mode
HSWIR	HS Warm Inter-unit Harness	0.1 W	
	Total	95.3 W	

The above dissipations are essentially independent of observing mode, with the exception that the baseline is to power EITHER the spectrometer OR the photometer bolometer systems at any one time. The above figures are based on the higher dissipation values expected with *photometer* operation. When operating in

spectrometry mode, the reduction in HSDCU power requirements and the associated reduction in conditioning losses in the HSFCU are TBD.

The baseline is to empower either prime or redundant modules of Spire. The instrument will therefore appear to the S/C as simply cold redundant.

5.9.4 Power on Planck Payload Module

NA

5.9.5 Power versus Instrument Operating Modes

The table below shows the status of the instrument subsystems in the various instrument modes.

Unit	Subsystem	Recycle	Off	On	Standby/ Parallel/ Serendipity	Observing	
						Photom.	Spectro.
HSFPU	Detector Bias	OFF	OFF	OFF	ON	ON	ON
	Photometer Cal Source	OFF	OFF	OFF	OFF	X	OFF
	Spect. Cal Source	OFF	OFF	OFF	OFF	OFF	ON
	Cooler	ON	OFF	OFF	ON	ON	ON
	BSM	OFF	OFF	OFF	ON	ON	ON
	FTS Mechanism	OFF	OFF	OFF	OFF	OFF	ON
HSFTB	JFET amplifiers	OFF	OFF	OFF	ON	ON	ON
HSFCU + HSDCU	Read-out electronics & mechanism drive electronics	ON	OFF	OFF	ON	ON	ON
HSDPU	Digital Processing Unit	ON	OFF	ON	ON	ON	ON

LEGEND	
ON :	Operational
OFF :	Inactive
X :	Either ON or OFF depending on instrument configuration.

5.9.6 Supply Voltages

5.9.6.1 Load on main-bus

The total power load Spire places on the 28V main-bus is defined In the Spire Budgets' Document. The following is an extracted summary:

Reference **HP-SPIRE-REQ-0020**

The SVM shall provide the allocated power budget as defined hereafter.
 The "average" and "peak" power values correspond to "worst-case" conditions, i.e. taking into account the specified supply bus voltage range : 26V and 29V.

Spire Operating Mode	¹ Max. Ave. BOL	¹ Max. Ave. EOL	¹ Long Peak BOL/EOL
Observing	95.3 W	95.3 W	TBD
Parallel	95.3 W	95.3 W	TBD
Serendipity	95.3 W	95.3 W	TBD
Standby	95.3 W	95.3 W	TBD
Cooler Recycle	95.3 W	95.3 W	TBD
On	15.3 W	15.3 W	TBD
Off	0 W	0 W	0

Project Code	Instrument Unit	Mean load per LCL
HSDPU	HS Digital Processing Unit	15.3 W ²
HSFCU	HS FPU Control Unit	80.0 W ³

1 The "average" and "peak" power values correspond to "worst-case" conditions, i.e. taking into account the specified supply bus voltage range : 26V ~ 29V. The average "with-margin", and peak "with-margin" total power loads are also to be provided. 2 The **maximum** associated "Long Peak" load on this LCL is understood to be the mean value (above) X 1.20, i.e. 18.5 W.

3 The **maximum** associated "Long Peak" load on this LCL is understood to be the mean value (above) X 1.20, i.e. 96 W.

5.9.6.2 Power Nominal Turn-on.

Having checked that Spire is all unpowered, the HPCDU shall empower an HSDPU (P or R).

This DPU checks its health and sends a status packet on the active 1553 bus. If its status is OK, the HCDMU commands the HPCDU to turn on the corresponding HSFCU module (P or R).

Note that turning on the HSFCU has the automatic subsidiary effect of turning on the non-redundant DCU, but this unit is not seen directly via a S/C interface.

5.9.6.3 Interface circuits

Reference **HP-SPIRE-REQ-0030**

The HSDPU and the HSFCU receive both primary and redundant 28V feeds. The configuration is shown in figure 5.2.1, and the connectors are HSDPU J1-2 and HSFCU J5-6.

Their S/C power interfaces circuits shall be designed not to generate unwanted interactions with LCL switching limiters. Instrument power circuits are shown in sections 5.9.6.4.1 & .2.

Reference **HP-SPIRE-REQ-0040**

The HPCDU shall telemeter the Spacecraft's LCL current to a resolution of better than 25mA or 1/256 of (trip x 1.5), whichever is the larger. The stated resolution, to be provided by the current telemetry, does imply any particular level of current measurement accuracy.

5.9.6.4 LCL fault conditions

Reference **HP-SPIRE-REQ-0050**

The S/C shall not allow simultaneous powering of both FCUs, even in the event of a single point LCL failure.

Reference **HP-SPIRE-REQ-0060**

Both DPUs may be powered but only under LCL fault conditions. To permit this, other design features must be present. The unwanted although powered DPU shall be kept in-active by not commanding the inactive unit, and neither HCDMU shall turn on the corresponding HSFCU. To permit commanding the DPUs to work like this, each HSDPU uses a different 1553 bus address.

The Herschel platform shall monitor that LCL's are behaving correctly. With certain timing restrictions, it shall regularly check that an "off" LCL is passing less than a minimum current, and that an "on" LCL is passing a current between a minimum and a maximum that depends on circuit. It shall re-check this before and after implementing a command to change an LCL's state. The formal status of the functionality of LCLs [working, stuck on, stuck open-circuit, dubious, etc.] shall be stored somewhere in the Herschel commanding system (probably on the ground?) to stop any attempt to switch a failed LCL without specific over-ride .

An open-circuit LCL is not a particularly difficult case to consider as it would just preclude the use of one side of Spire.

5.9.6.4.1 HSDPU Power Input Circuit Configuration

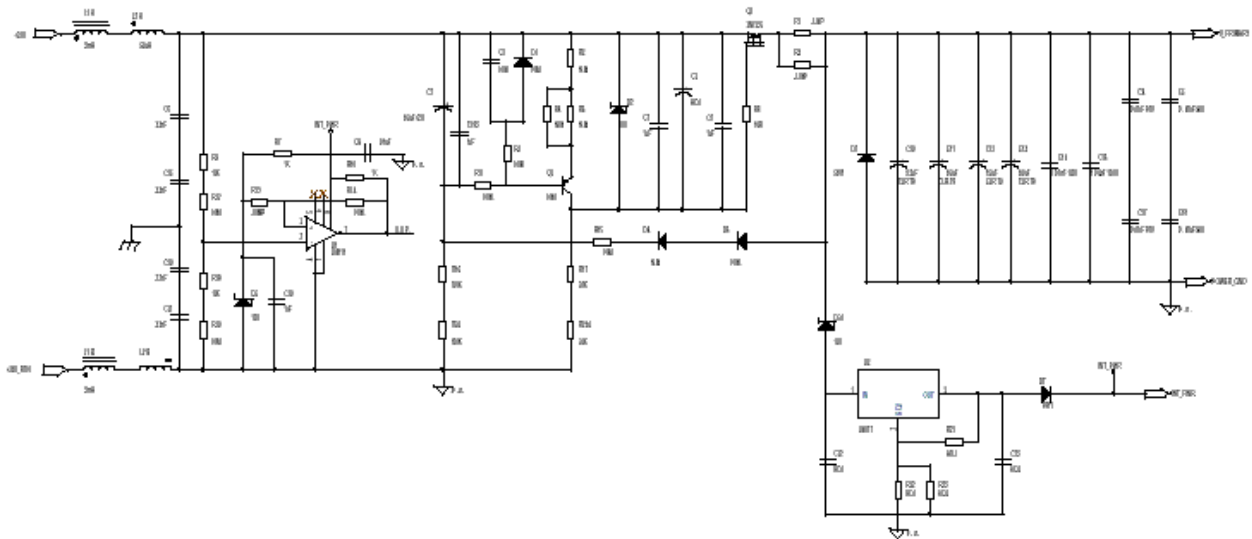

5.9.6.4.2 HSFCU Power Input Circuit Configuration

TBW

5.9.7 Keep Alive Line (KAL)

Because Spire should not be switched-on/off frequently, a KAL will not be implemented.

5.10 CONNECTORS, HARNESS, GROUNDING, BONDING

Spire provides the SVM interconnect harnesses wired as per RD-19, and suitable for routing/installation on the SVM as illustrated in the IID-A as regards length, connector back-shells, etc. This is illustrated in figure 5_3.x (as in section 5.3.1.1).

Herschel provides the "cryoharness" between the warm Spire units and the cryogenic ones on the HOB inside the CVV. Figure 5.2.1 illustrates how these are all in three sections, S, I and C.

The function pin allocations in the cryoharness has adopted RD-19's definitions up to issue 1.1 with corrections (i.e. updated pages, given in Annex 5).

External to the CVV the harnesses are double isolated shielded, with the outer shield linking the CVV connector bodies to the warm unit connector backshells and the inner one also linked to the warm unit connector backshells but passing through the CVV connectors on a ring of pins to join to the HSFPU+JFET Faraday shield.

Internal to the CVV there are no harness overshields. For the bolometer harnesses, C1-C9, the Faraday shields are carried on internal cable when the second outer cable shield is connected to the connector backshells. For the non-bolometer harnesses, C10-C13, these links are discrete wires rather than a closed shield.

This implementation is consistent with the grounding drawing figure 5.10-2

5.10.1 *Harness and Connectors*

The cryoharness interface pinout shall be compliant with RD-19, SPIRE-RAL-PRJ-000608, Issue 1.1 and updated pages, for harness bundles 4 and 6, identified by:

"SPIRE HDD 1.1 Deltas", ref SPIRE-RAL-NOT-001819, Issue 3, dated 23/10/2003

This "SPIRE HDD 1.1 Deltas" document is given in Annex 5.

The Spire harnesses shall be compliant with the requirements specified in Annex 3 (Summary of SPIRE cryoharness wiring functions)

Figure 5.10-1 below gives an overview of the Spire harness layout.

Note that the Cryo-harness, i.e. series C, I, and S are ESA provided and not Spire flight H/W, whilst the T series apply only for instrument test and are not Spire flight items.

The two F harnesses (FPU sub-system F harness) between JFETs and FPU (HSFPU-HSJFP and HSFPU-HSJFS) are provided by SPIRE with the instrument units.

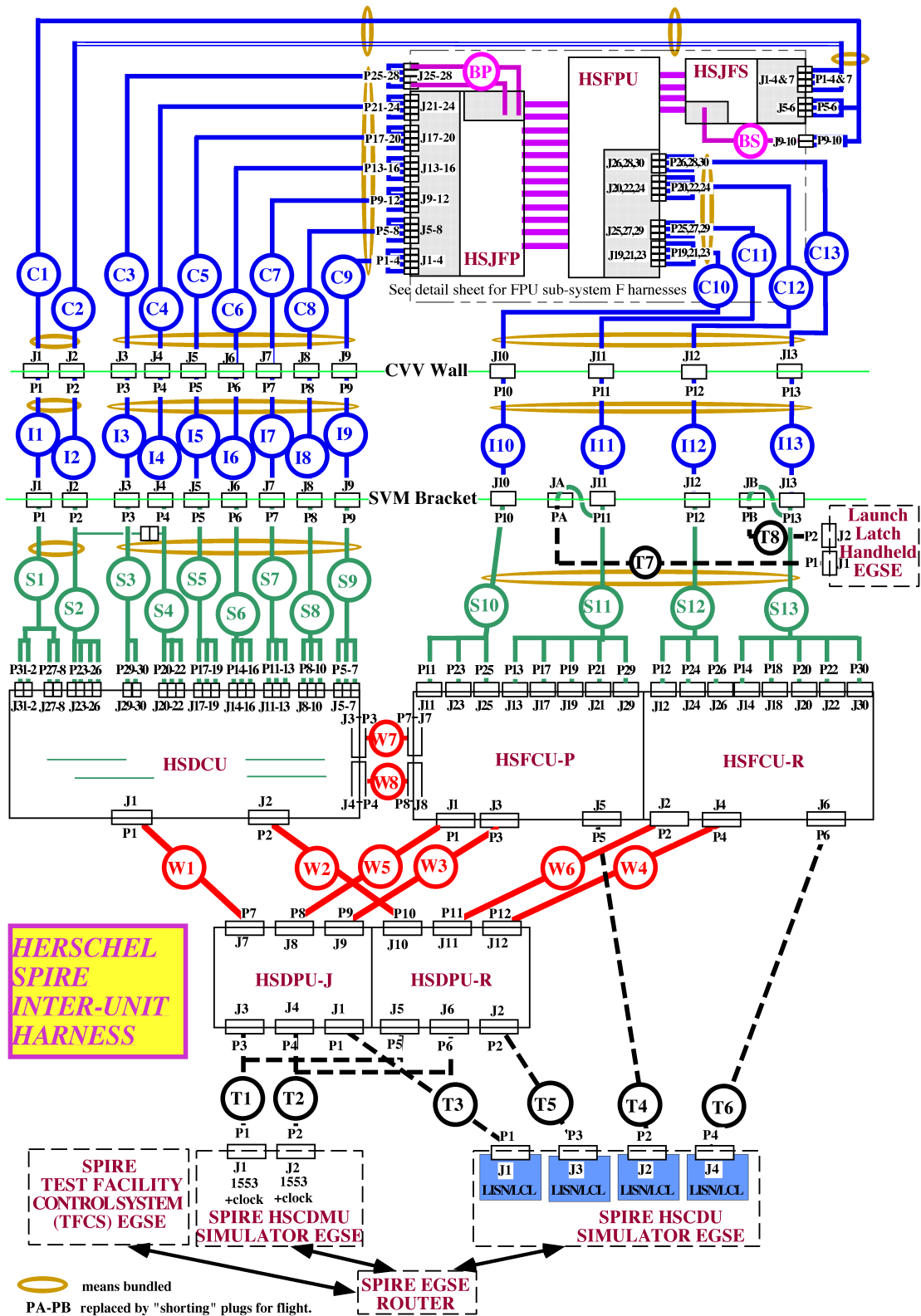

Figure 5.10-1 : SPIRE harness layout

5.10.2 Grounding

To fulfil Spire's grounding requirements, the HSFPU and both of the JFET racks need to be electrically isolated from the Optical Bench, at their mechanical mounting points. The same applies to the bolometer system harness screens.

SPIRE grounding diagram provided in the figures 5.10-2 and 5.10-3 below is for information.

The mechanical implementation of thermal straps insulation is described in section 5.6.1.2

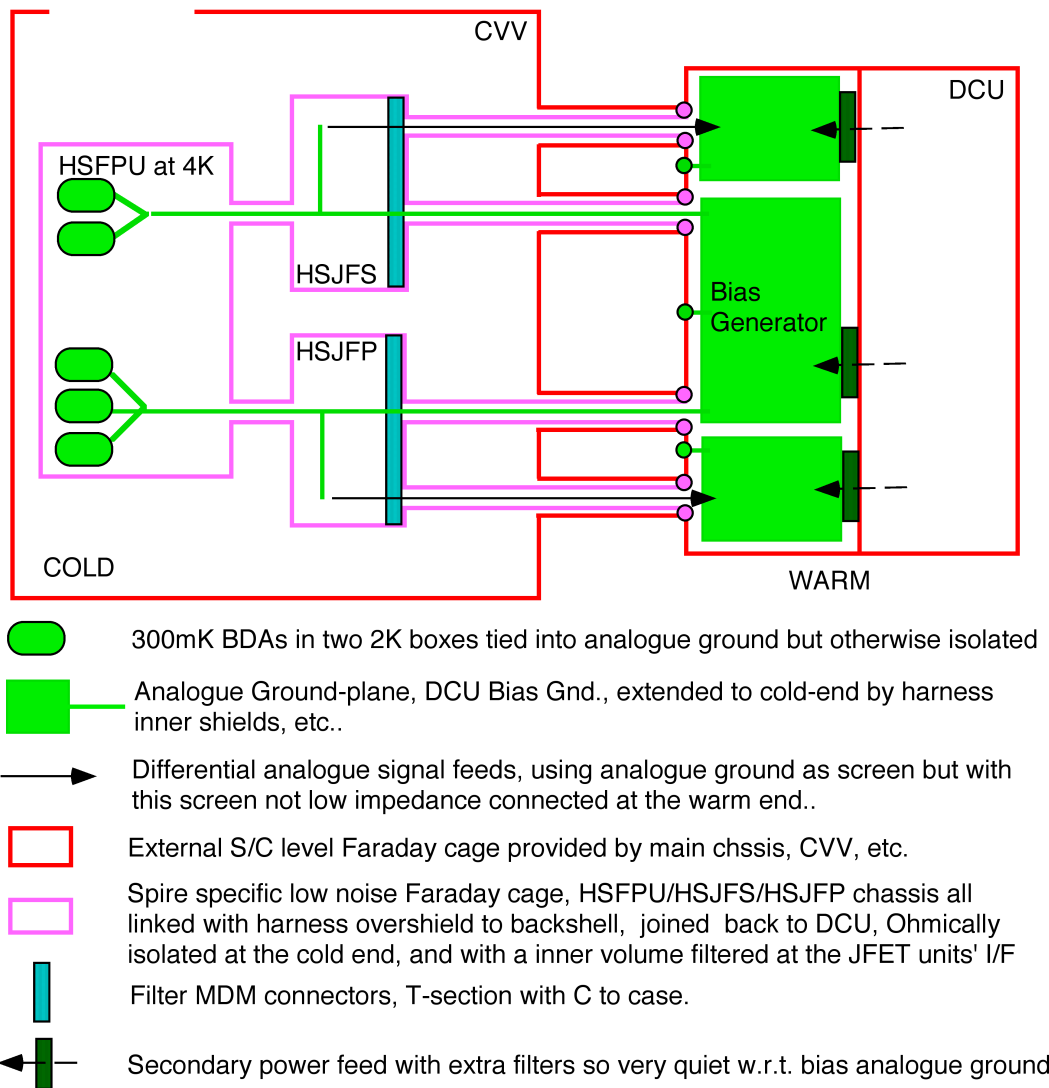

Figure 5.10-2 : SPIRE Simplified Grounding scheme

The Spire FCU itself and the DPU use a "standard" ESA-type secondary power system, whereas the DCU/FPU and FCU supply sections shown above are an optimised system w.r.t. minimising the overall bolometer analogue ground noise. The FCU powers the DCU, keeping the latter free of conditioning noise. The FCU driven items in the FPU, see figure 5.2.1, are considered less critical and will all be Ohmically grounded in the FCU.

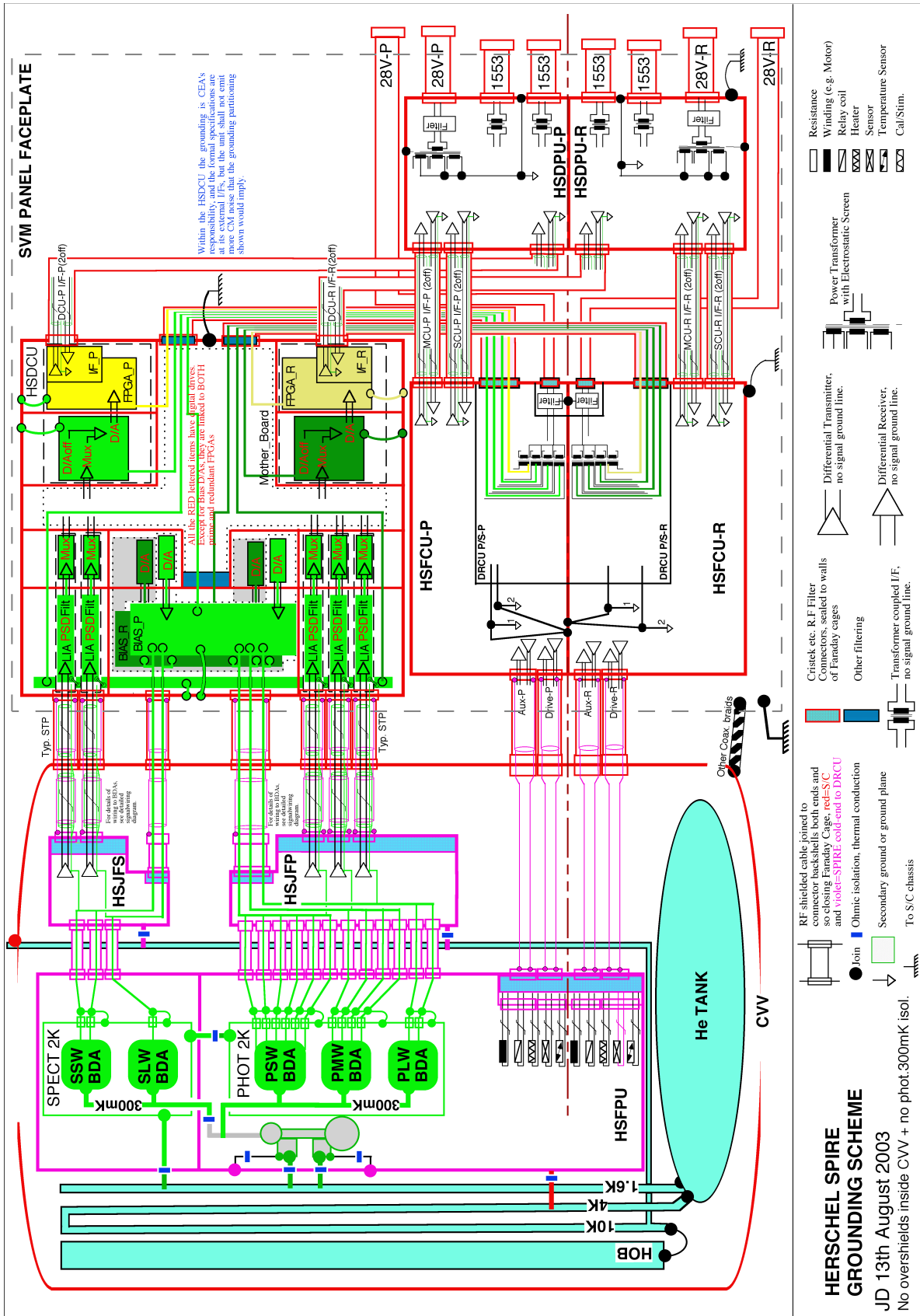

Figure 5.10-3 : SPIRE Grounding scheme

5.10.3 Bonding

It is understood that Herschel bonding applies to harness shields used to maintain closed Faraday cages. Bonded interfaces shall not be used as routine current return paths.

We note that presently all Warm Electronics units rely in conductivity via their mechanical mounting feet to S/C.

The DRCU decreases interface inductance by using conductive interface gasket, see Annex 1

A bonding strap is connected to each SPIRE SVM mounted unit.

5.10.4 Electrical Signal Interfaces

5.10.4.1 1553 Data Buses

Reference **HP-SPIRE-REQ-0070**

The 4 interfaces to the two (prime and redundant) buses between the Spire instrument DPUs and the CDMU shall conform to MIL-STD-1553B, with the CDMU controlling the bus.

*

Reference **HP-SPIRE-REQ-0080**

The 4 Spire interfaces shall have unique bus addresses, consistent with Herschel properly controlling the use of Prime and Redundant equipment.

*

Reference **HP-SPIRE-REQ-0090**

A long stub configuration shall be used for each of the 4 interfaces, one transformer for each stub in the bus wiring and one in the instrument I/F.

*

Reference **HP-SPIRE-REQ-0100**

Connector use is as follows:

DPU Connector	Prime Bus	Redundant Bus
Prime DPU	J3	J4
Redundant DPU	J5	J6

*

The DPU's 1553B interface to the Herschel S/C is configured as follows inside each SPIRE HSDPU :

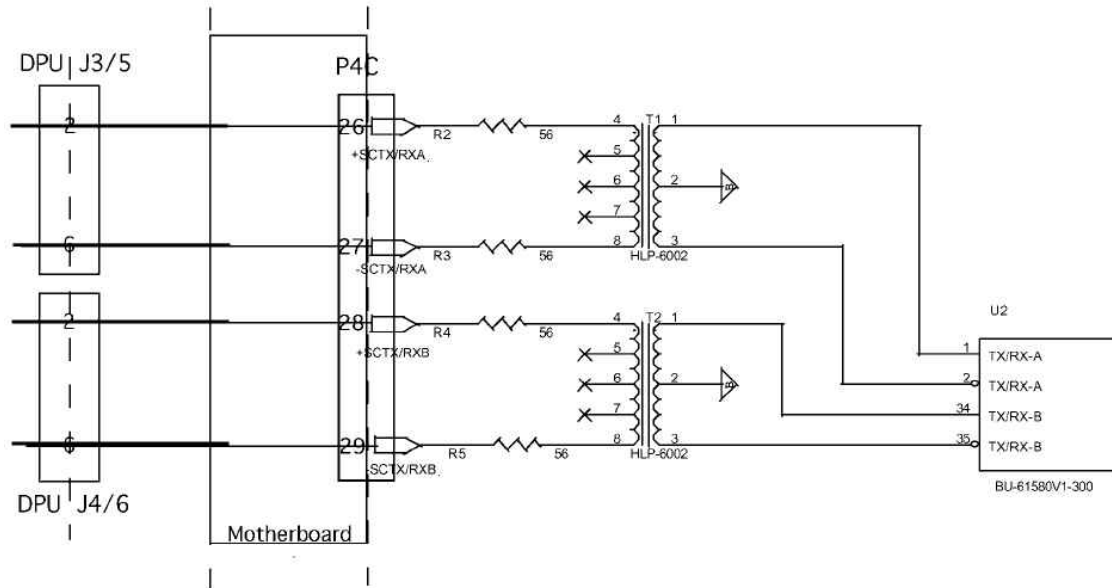

5.10.4.2 Master Clock

Reference **HP-SPIRE-REQ-0110**

Herschel shall supply 2 differential signal lines of 2^{17} Hz (131 kHz). master clock signals. They are therefore supplied unground-referenced. These are shown as brown lines in figure 5.2.1.

Reference **HP-SPIRE-REQ-0120**

Electrical interface details are standard digital differential receiver, through DPU connectors J3 and 5, i.e. bundled with primary 1553 bus.

Reference **HP-SPIRE-REQ-0130**

This shall be supplied to both powered and un-powered Spire HSDPUs.

Reference **HP-SPIRE-REQ-0140**

Note that Herschel arranges the OR-ing of the functions over Prime and Redundant CDMU so that Spire is unaffected by which one is active.

S/C wide synchronisation of dc-dc converters, will NOT be implemented.

5.10.4.3 Launch Latch confirmation

Spire has two cryogenic mechanisms: BSM and SMEC. It is baselined that each will need to be launch-locked and that their latching will need to be confirmed after launch stack integration. All functions are Prim, and Redundant.

After transportation to Kourou, and the last operation of SPIRE prior to launch, hand-held Spire provided EGSE will require cable access to the two connectors JA and JB shown in the Harness configuration drawing.

Connector blanking plugs PA-PB that interconnect connector contacts as defined by Spire will be HERSCHEL provided and fitted whenever the EGSE is not connected, which includes in-flight.

5.11 DATA HANDLING

5.11.1 Telemetry

5.11.1.1 Telemetry rate

The instrument produced «raw» housekeeping and science data rates, given for information purposes, are as follows:

Description	Data rate (Kbps)
Housekeeping data rate (non-prime)	2.1
Housekeeping data rate (prime)	2
Science data rate: Photometer only	93.6
Science data rate: Spectrometer only	97.4
Science data rate: Parallel mode	10
Science data rate: Serendipity mode	87

Any increase in telemetry rate would have science benefits. Note that the data rate allocation of 100Kbps is a limit on the average including orbit recycling/commanding periods

Reference **HP-SPIRE-REQ-0150**

SPIRE requires an average of 100 kbps of TM data rate during operations, and 2.5 kbps when in stand-by mode.

5.11.1.2 Data-bus rate

Reference **HP-SPIRE-REQ-0160**

For the purpose of possible (up to 5 minutes) higher instrument data-rates, the bus interconnecting the instrument and the HCDMU shall have the capability of handling a telemetry rate of > 200 kbps TBC.

This will allow for the rapid emptying of Spire on-board data storage units at the end of each observation, thus keeping overheads due to data transfer to a minimum.

5.11.1.3 Data Packets

Spire is capable of buffering 10 seconds of data at 100kps.

Reference **HP-SPIRE-REQ-0170**

In order to prevent data overflow in this Spire data storage, the HCDMU shall request packets from Spire at least as frequently as once per second (TBC).

5.11.2 *S/C housekeeping*

Reference **HP-SPIRE-REQ-0180**

The S/C should be capable of collecting and range checking the following instrument parameters every minute. It shall provide a data packet to the ground that includes these housekeeping values, together with any range violations and any actions taken thereon.

- Voltages to instrument
- Currents to instrument
- Power status – i.e. which Spire units are on i.e. HSDPU and HSDRC.
- Requested temperatures in Section 5.7.5.2.

5.11.3 *Timing and synchronisation signals*

Reference **HP-SPIRE-REQ-0190**

The S/C shall provide Spire with a timing synchronisation at least once per 24 hours to allow cross reference or synchronisation of the Spire clock to the spacecraft clock.

Reference **HP-SPIRE-REQ-0200**

So when using the telescope scan mode, a «start of scan» indication will be sent to the DPU to give a timing precision of better than 5 milliseconds, although the actual UT of the pulse only needs to be within one second of its planned time.

This is required so that the Spire data can be located in time and correctly ground processed to link to Herschel attitude; it is not required for the operation of the Spire instrument.

The Spire instrument typically works by its DPU unpacking S/C commands to a lower level, and sending those lower level commands to the DCU and FCU with timings that they can guarantee to keep up with. There is a minimum of handshaking on internal interfaces and, for instance, the DPU has to be ready to receive science data packets from the DPU and FCU whenever they reasonably send them. In these internal data packet headers are counter values permitting accurate datation of all values back to sequence start pulses sent from the DPU. The scheme can be viewed as:

SPIRE DATA TIMINGS

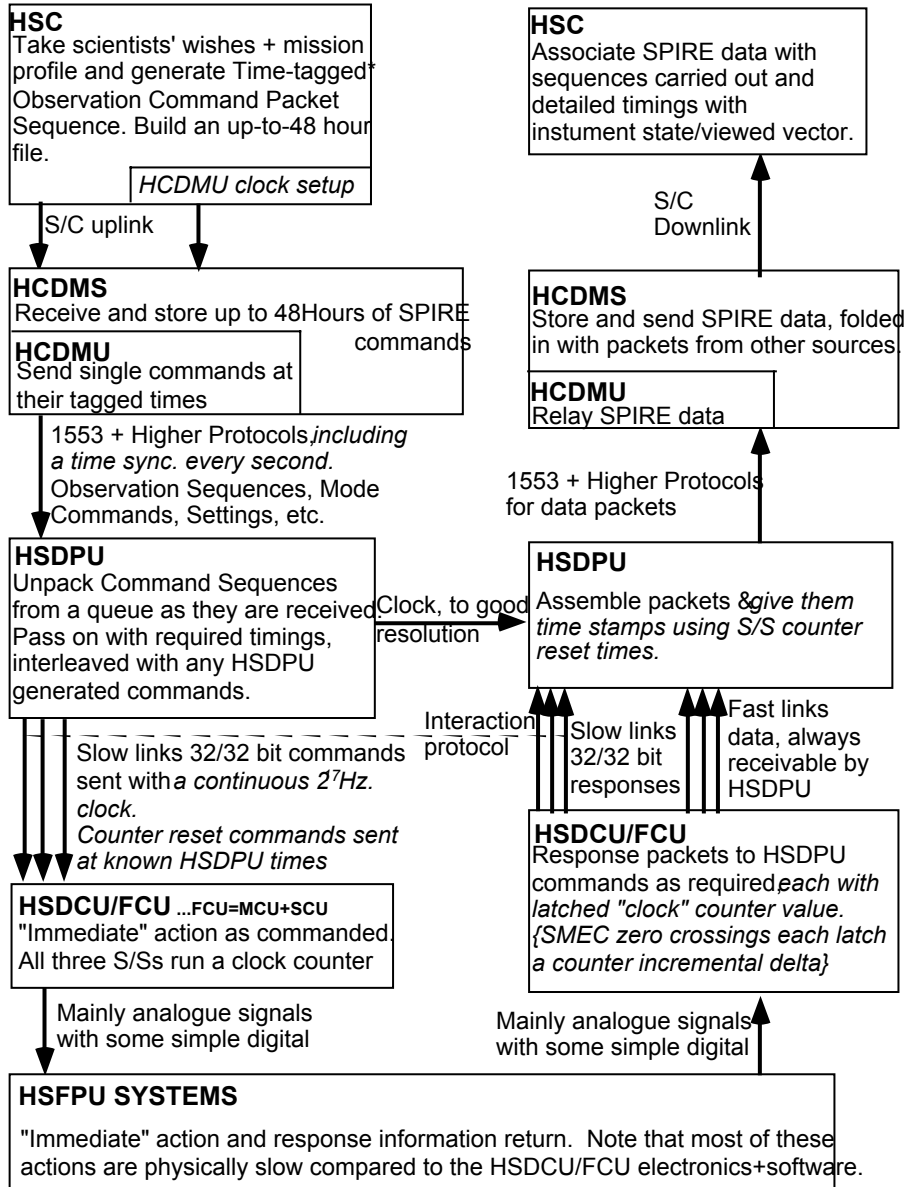

*This process uses known worst case timings for SPIRE operation + margin to ensure that the plan can be implemented and timed starts will not slip.

Note that for the above scheme to work, either the DCU/MCU/SCU need to have no input FIFOs, or the DPU needs to know that they are empty and a reset will go straight through, or these units need to check for the reset pulse in hardware before feeding other packets into a FIFO. TBD.

5.11.4 *Telecommand*

It is assumed that the observation schedule for each 24 hour period will be uplinked during the data transfer and commanding phase (DTCP). It is further assumed that the correct receipt of all Spire commands is verified by the S/C during the DTCP.

Reference **HP-SPIRE-REQ-0210**

The maximum rate of sending command packets from the CDMS to the Spire instrument is less than 10 per second.

Reference **HP-SPIRE-REQ-0220**

The maximum telecommand packet length is 256 octets.

Reference **HP-SPIRE-REQ-0230**

All Spire telecommands are defined in document RD3.

5.12 ATTITUDE AND ORBIT CONTROL/POINTING

5.12.1 *Attitude and orbit control*

For information, Spire has the following **instrument** pointing modes:

- Peak up mode. The ACMS pointing ability quoted in the IID-A (3.7 arcsec APE – see also section 5.12.2) will not be good enough to prevent unacceptable signal loss when observing point sources with the photometer or spectrometer. The Spire beam steering mirror will be used to perform a cruciform raster over the observation target and the offset between the required pointing and the actual pointing of the telescope will be provided via an ACMS Data Packet (TM(5,1) from the Spire instrument to the S/C. The S/C will then adjust the pointing accordingly.
- Nodding mode. If the telescope temperature stability time constant proves to be short compared with a typical pointed observation with Spire; then the telescope must be capable of being pointed to another fixed position on the sky between 10 arcsec and 4 arcmin from the original pointing in an arbitrary direction with respect to the spacecraft axes. The transition time between the 2 position for 4 arcmin apart shall be less than 32s.
- Line scan mode. To map large areas of the sky, the telescope must be capable of being scanned up to 20 degrees at a constant rate in an arbitrary orientation with respect to the spacecraft axes. The rate of scan must be variable between 0.1 arcsec/sec and 60 arcsec per second. It is expected that the RPE will be maintained in the orthogonal direction during the scan. The S/C must be capable of reaching any scan speed up to the maximum within 20 seconds of the observation commencing.
- Raster mode. To finely sample the Spire FOV the instrument beam steering mirror will be used to step the FOV across the sky in an arbitrary direction. The step size will be between 1.7 arcsec and 30 arcsec. The beam steering mirror can also be used to chop a portion of the Spire FOV at a rate up to 2 Hz.
- The S/C is specified as being able to perform its own raster mode, i.e. stepping the FOV of the overall Herschel telescope view to follow predetermined patterns. This is acknowledged to be much less efficient than using the internal Beam Steering Mirror (BSM), but is needed as a backup in the event of Spire BSM failure. The spacecraft shall be capable of performing a rectangular raster with steps of between 2 and 30 arcsec in any arbitrary orientation with respect to the S/C axes.
- To map extended regions using the spectrometer, the Spire instrument will use the Herschel telescope Normal Raster Mode. The instrument may perform fine sampling of each raster pointing using its internal BSM.

5.12.2 *Pointing*

The Spire instrument requires an absolute pointing error of better than 1.5 arcsec r.m.s. (TBC), and a relative pointing error of better than 0.3 arcsec r.m.s. per minute.

This is achieved by the peak up mode in case the pointing goal values are not fully achieved by the S/C.

Spire requires to be able to deduce where Herschel is pointing to 0.1 of its smallest pixel IFOV.

5.12.3 *On-Target Flag (OTF)*

For pointed observations, SPIRE requires, an On-Target Flag. It will be provided in the spacecraft telemetry, and will specify the acquisition time to a precision of better than 0.1 second (TBC). This is required for the correct processing of the Spire data on the ground; it is not required for Spire operations.

5.13 ON-BOARD HARDWARE/SOFTWARE AND AUTONOMY FUNCTIONS

5.13.1 On-board hardware

There is a single on-board computer in each of the prime and redundant SPIRE HSDPUs. Each HSDPU shall have a different 1553 address. The HSDPUs have the only non-hard-coded on-board software used in SPIRE.

5.13.2 On-board software

It is assumed that the Spire warm electronics will remain powered during all operational phases. The DPU will download baseline software from ROM during power up but some additional software may be required (TBD) to be unlinked before observations commence, either patches or whole modules/objects.

No single instrument command nor any sequence of instrument commands will constitute a hazard for the instrument so the HSDPU is required to trap out any such situations. For the same reason, the HSDPU shall ensure its own correct function, at least as far as checking memory function in the background, check-summed read only areas, and an inhabitable SEU safing capability.

5.13.3 Autonomy functions

Reference **HP-SPIRE-REQ-0240**

The S/C must be capable of automatic monitoring all SPIRE Housekeeping parameters, i.e. the parameters listed in section 5.7.5.3 when the S/C is not in ground contact.

*

Reference **HP-SPIRE-REQ-0250**

The S/C must be capable of taking predefined action – e.g. switching off the power to the Spire instrument - when an error or hard limit is detected in the SPIRE S/C housekeeping.

*

Reference **HP-SPIRE-REQ-0260**

The S/C must be capable of receiving and interpreting Spire «Event Data» packets that will alert the S/C of errors or hard limits detected by the Spire DPU autonomy monitoring software. Again the S/C must be capable of taking the appropriate pre-defined action on detecting an error alert in the Spire Event Data.

*

5.13.4 Instrument Autonomy Housekeeping Packet Definition

N.A.

5.13.5 Instrument Event Packet Definition

TBD

5.14 EMC

5.14.1 Conducted Emission/Susceptibility

None to be found under required test conditions

5.14.2 Radiated Emission/Susceptibility

None to be found under required test conditions

5.14.3 Frequency Plan

The Spire frequencies are arranged to minimise noise problems in the bolometer sub-system's highly sensitive analogue sections, and are provided in the following table.

SPIRE Unit	Frequency Source – subsystem	Frequency Range		Wave-form	Signal level(s)		Comments
		Lower	Upper				
DCU	Cmd IF Clock	312 kHz		Rect.	0	5 V	Differential RS422 – Continuous
	Data IF Clock	1MHz	2.5 MHz	Rect	0	5 V	Differential RS422
	Master Clock	10 MHz		Rect		5 V	Crystal Oscillator – Internal to unit
	Bolometer Bias	50 Hz	300 Hz	Sine	0	100 mV	Differential – Highly sensitive signal
	T/C Bias	50 Hz	300 Hz	Sine	0	500 mV	Differential – Highly sensitive signal
MCU	Cmd IF Clock	312 kHz		Rect.	0	5 V	Differential RS422- Continuous
	Data IF Clock	1MHz	2.5 MHz	Rect	0	5 V	Differential RS422
	Master Clock	40 MHz		Rect		5 V	Crystal Oscillator – Internal to unit
	DSP Clock	20 MHz		Rect		5 V	Master clock / 2 - Internal to unit
	LVDTextcitation	2.5 kHz		Sine		3 V	Differential +/- 20 %
	DAC change	3.0 kHz	10 kHz	Rand.		10 V	Internal to unit
	Position encoder	0	2.5 kHz	Sine		3 mV	Differential 250 Hz at nominal speed
SCU	Cmd IF Clock	312 kHz		Rect.	0	5 V	Differential RS422- Continuous
	Data IF Clock	1MHz	2.5 MHz	Rect	0	5 V	Differential RS422
	Master Clock	10 MHz		Rect		5 V	Crystal Oscillator – Internal to unit
	300 mK TS Bias	20 Hz		Rect		6 mV	Tr/Tf = 1 ms Highly sensitive signal
	Photo Stimulus	0	5 Hz	Rect			
PSU	DC/DC switching frequency	131 kHz TBC					Free runing - ± 10% - internal to unit

Note: PSU DC/DC switching frequency to be confirmed/clarified by SPIRE

5.15 Transport and Handling Provisions

5.15.1 Focal Plane Unit

For reasons of possible damage caused by vibration during transport, environmental testing and launch, mechanisms shall be transported in their launch-latched state.

5.15.1.1 Transport Container

The Spire FPU (HSFPU) will be transported in a clean hermetically sealed container to be opened only in class 100 clean conditions (TBC) with less than 50% humidity (TBC).

The maximum shock the HSFPU can sustain in any direction is (TBD). The transport container is fitted with shock recorders and internal humidity monitors. The HSFPU transport container is shown in figure TBD.

5.15.1.2 Cooling and Pumping restrictions

During cryostat warm-up or cool-down phases:

- Above 50 K the rate of temperature change dT/dt shall not exceed 20 K/hour (TBC).
- The rate of depressurisation/pressurisation dP/dt shall not exceed 50 mBar/hour (TBC). As a goal this rate dP/dt shall not exceed 100 mbar/h

5.15.1.3 Mechanism positions

For reasons of possible damage caused by vibration during transport, environmental testing and launch, mechanisms shall be placed in the TBD position. This position is shown in table TBD.

5.15.1.4 Unpacking Procedure

The procedure for removing and installing the HSFPU from its transport container is given in document TBW

5.15.2 JFET/Filter Boxes

5.15.2.1 Transport Container

The Spire JFET/Filter Boxes (HSFTP/S) will be transported in a clean hermetically sealed container to be opened only in class 100 clean conditions (TBC) with less than 50% humidity (TBC).

The maximum shock the HSFTP/S can sustain in any direction is (TBD). The transport container is fitted with shock recorders and internal humidity monitors. The HSFTP/S transport container is shown in figure TBD.

5.15.2.2 Unpacking Procedure

The procedure for removing and installing the HSFTP/S from its transport container is given in document TBW

5.15.3 *Electronics Units*

5.15.3.1 Transport Container

The Spire warm electronics units (HSDPU; HSFCU; HSDCU, HSWIH) will be transported in clean hermetically sealed containers to be opened only in class 100 000 clean conditions (TBC) with less than 75% humidity (TBC).

The maximum shock any of the warm electronics units can sustain in any direction is (TBD). The transport containers are fitted with shock recorders and internal humidity monitors. The Spire warm electronics transport containers are shown in figure TBD.

5.15.3.2 Unpacking Procedure

The procedures for removing and installing the Spire from warm electronics units their transport containers are given in document TBW

5.16 DELIVERABLE ITEMS

Note 1: All section 5.16 to be updated and clarified by SPIRE according the new model philosophy and AIV plan

Note 2: All ICD/drawings of deliverable AVM/CQM to be provided by SPIRE

5.16.1 Instrument Models.

The model philosophy to be adopted for the AIV of the Herschel Spire instrument will be in accordance with the Spire Development Plan and Model Philosophy, RD5.

In outline, the instrument models to be produced are:

- AVM – The Avionics Model shall permit us «...to validate electronics and software for its interface with the S/C, including anything that exchanges information with, for example, the AOCS. In addition all tasks relevant to Spire autonomy shall be verified.» This requires a DPU in at least form, fit and function plus a simulator of the DRCU and cold FPU – collectively termed the DRCU Simulator. As the schedule demands that this model will be delivered almost simultaneously with the CQM, it is planned to use the CQM DPU in the AVM.
- CQM - Cryogenic Qualification Model. For both the cold FPU and the warm electronics it is assumed that this is built to flight standards, but not necessarily using flight quality electronic components. The performance capabilities of the instrument may be less than the proto-flight model - i.e. fewer pixels in the focal plane arrays, but it will mimic as exactly as possible the thermal, electrical and mechanical properties of the flight instrument and will be capable of under going the full environmental qualification programme
- PFM – Proto-Flight Model. This will be the model that is intended for flight, built to full flight standards. The PFM will therefore undergo environmental test to qualification levels for acceptance times (TBD) - this applies to both the warm electronics boxes and the cold FPU. A CQM qualification review will determine if in fact the PFM has needed sufficient updates that full re-qualification is needed in some respects.
- FS – Flight Spare. The flight spare cold FPU will be made from the refurbished CQM (TBC). The flight spare warm electronics will consist of spare electronics cards/modules/harness.

5.16.2 Electrical Ground Support Equipment (EGSE)

Electrical Ground Support Equipment (EGSE) will be needed to provide Spire instrument level monitoring during instrument integration with the S/C and system level testing.

Deliverables:

- FPU electrical simulator, including simulation of the HSFTP/S, to enable integration of the HSDCU, HSDPU, HSFCFU and HSWIH
- TBD EGSE for integration of the HSFPU
- Quick Look Facility to enable testing of the instrument at system level. This will interface to the S/C test environment

Note: EGSE deliverables (including connectors savers and caps) to be clarified by SPIRE

5.16.3 Mechanical Ground Support Equipment (MGSE)

MGSE is required to ensure safe handling of all instrument components during assembly integration and test procedures.

Deliverables:

- Transport containers
- Instrument to cryostat integration jigs/equipment
- Plus TBD

Note: MGSE deliverables (including protective caps) and hoisting provisions to be clarified by SPIRE

5.16.4 Optical Ground Support Equipment (OGSE)

OGSE is required to carry out alignment procedures with the telescope.

The SPIRE alignment can be removed following the FPU alignment to the Herschel Optical Bench

Deliverables:

- Instrument optics primary alignment and alignment verification jigs/equipment
- Plus TBD

Note: OGSE deliverables (alignment cube + ...) to be clarified by SPIRE

5.16.5 System Test Software

Will be based on the Quick Look Facility - computers and software that allow the monitoring in near real time of the instrument housekeeping parameters and instrument data. This is the basic facility to be used for the ICC operations monitoring for the monitoring of the instrument in-orbit. The same facility with enhanced capabilities will be used for the ground tests and in-orbit check out of the instrument.

5.16.6 Hardware for the Observatory Ground Segment

Quick Look Facility for the Mission Operations Centre for instrument in-flight commissioning. This will consist of TBD workstations etc....and must be identical to the system used for instrument system level testing.

Note: to be clarified by SPIRE

5.16.7 Software for the Observatory Ground Segment

The software for the Quick Look Facility will be delivered to the MOC for instrument in-flight commissioning.

Plus TBD.

Note: to be clarified by SPIRE

5.16.8 Instrument Software Simulator

TBD

Note: to be clarified by SPIRE

5.16.9 Test Reference Data

The Spire instrument test reference data will be delivered in the TBD form generated during instrument and system level testing.

Note: to be clarified by SPIRE

5.16.10 Instrument Characterisation Data

The Spire instrument characterisation data will be delivered in the TBD form generated during instrument and system level testing.

Note: to be clarified by SPIRE

5.16.11 Technical Documentation

The following documents will be delivered:

- Instrument User Manual following the requirements laid down in the OIRD (AD3)
- Instrument database – this will be delivered in the TBD form generated during instrument and system level testing.
- Each instrument model will be delivered with an Acceptance Data Package consisting of TBD....

Note: to be clarified by SPIRE

6. GROUND SUPPORT EQUIPMENT

6.1 MECHANICAL GROUND SUPPORT EQUIPMENT

TBD -To be clarified by SPIRE

6.2 ELECTRICAL GROUND SUPPORT EQUIPMENT

In agreement with all the other instruments of Herschel/Planck the SPIRE EGSE will be implemented using SCOS2000.

In order to achieve the benefits of smooth transition between different mission phases and maximum reuse of resources, this system will also be used during instrument-level testing, system level tests and in the operational phases of the mission. In particular, the interface between the EGSE and the MOC during the Commissioning and Performance Verification phases (and, for Herschel only, contingency activities during the normal operations phase) will be the same as that between the EGSE and the CCE. This interface, concerning telemetry, telecommanding, the instrument database and procedures will follow the standard defined by SCOS 2000.

Note 1: A SCOS 2000 definition document reference is to be provided by ESA and put in ADs .

Note 2: Recommended version of SCOS is 2.3E. The Alcatel CCS runs under this version.

Telemetry:

The SPIRE EGSE will be supplied with all telemetry packets from the satellite (or its simulator) in real time.

This telemetry interface will conform to the SCOS2000 telemetry ICD (ref: TBD).

Telecommanding:

The SPIRE EGSE will not require any commanding capability through the CCE. Instrument commanding will be implemented in the CCE in line with the methods of operation of the MOC.

Databases:

SPIRE will deliver the instrument database to the Prime Contractor through the standard SCOS2000 database interface mechanism (ref: TBD).

SPIRE expects the Prime Contractor to deliver the full satellite database through the same interface. This will allow checking of the correct implementation of the instrument database in the satellite database and allow the display and monitoring of S/C parameters during tests/operations at the system level.

Test procedures:

Test procedures, including command sequences, will be delivered in an agreed format (e.g. flow diagrams and descriptions) to the Prime Contractor who will be responsible for their implementation in the CCE.

Archive data:

It shall be possible to retrieve test data from the CCE off-line.

6.3 COMMONALITY

Taking into account that it is a fundamental design goal of the Herschel/Planck mission that commonality should be pursued to the maximum extent possible, the Herschel instrument teams have been actively engaged in investigating such possibilities.

6.3.1 EGSE

A common EGSE system has been developed as a collaborative effort between instrument groups.

In addition, it has been agreed that this system would be applicable at various times during all the phases of the mission listed below:

- Subsystem Level Testing
- Instrument Level Testing
- Module and System Level Testing
- In-orbit instrument commissioning
- Performance Verification
- Routine operations

In the interests of minimising the cost and maximising the reliability of such a system through the different phases the EGSE will:

- be based on SCOS 2000 – this system will be used in the ground segment by the MOC for controlling the satellite. The cost of the system (essentially free), its proven use in similar situations for other space projects and the support provided by ESOC, contribute to a cheaper and more reliable system.
- use the same interfaces between the EGSE and other systems, in order to improve reliability through reuse throughout the mission.
- Provide a constant implementation of the
 - Man Machine Interfaces
 - Data Archiving and Distribution facilities
 - On-board Software Management
 - On-board Maintenance (e.g. Software Development Environment, Software Validation Facility)
 - Common User Language (for Test procedures and in-orbit operations)

6.3.2 Instrument Control and Data Handling

All three Herschel instruments are using the same supplier (IFSI) for their on-board control and data handling hardware and software systems, which interface to the spacecraft. This has ensured commonality in the areas of;

- on-board microprocessors
- instrument internal interfaces
- On-board Programming language
- Software Development Environments
- Software Validation Facilities

In addition, the on-board software provides commonality in its non instrument-specific functions. A common instrument commanding scheme has also been agreed and will be implemented by the instrument teams.

6.3.3 Other areas

Other areas of possible commonality will be addressed by working groups set up as and when necessary. These may cover:

- Follow-up on Herschel Common Science System data archive activities
- A common approach to IA/QLA systems

7. INTEGRATION, TESTING AND OPERATIONS

Information in this chapter covers all instrument-related activities after the acceptance of SPIRE by ESA and its handover to the Contractor.

Note: all section 7 to be updated and clarified by SPIRE, in line with Integration and Test Plan.

7.1 Integration

Procedures detailing the individual integration steps will be prepared and reviewed in due time.

7.1.1 HPLM Integration

It is anticipated that the SPIRE Focal Plane Unit (HSFPU) and the SPIRE JFET boxes will be integrated separately onto the Herschel optical bench. Electrical and RF-shield connections would be made between these boxes after mechanical integration with the Herschel optical bench. Herschel cryoharness shall then be attached.

Note: to be clarified by SPIRE (separately or together ?)

This applies to both the CQM and PFM units.

Spire's mechanical alignment shall be checked after mounting, and its aperture cover removed as late as practical during the closing of CVV.

Note: to be clarified by SPIRE

7.1.2 PPLM Integration

NA

7.1.3 SVM Integration

The SVM warm units shall be first integrated as panels, and the SPIRE units linked by warm Spire warm harness and checked with the HSFPU simulator. Remove SVM static protection ...

Note: to be clarified by SPIRE

7.1.4 Herschel/Planck Integration

TBD

Note: to be clarified by SPIRE

7.2 Testing

After completion of the integration, be it at the level of the FPLM, PPLM, SVM or Herschel/Planck, a series of verification tests will be carried-out.

Each test will be defined in detail in a test procedure to be written by the Contractor, based on instrument group inputs. It will be reviewed and approved by the Herschel/Planck project group.

7.2.1 CQM Testing

Overview

The detailed system level test procedures for the SPIRE CQM are TBW. An indication of the type of testing anticipated for the SPIRE CQM is given below:

- FPU integration procedures
- Optical alignment procedures
- Integration with CCE
- Test of checkout procedures to be done for PFM
- Test of parallel operation with PACS
- Functional checks using standard test procedures
- Thermal balance tests under representative conditions. This will include cooler recycle and some mechanism operations.
- Test switching sequences between all modes. Check length of time required to change modes – including waiting for thermal environment to stabilise.
- Test thermal dissipation in each «operating mode».
- Straylight checks with GSE fitted or with final shield blanked off. This is an extreme test as the other shields will be at higher temperatures than expected in flight.
- EMC test of conducted susceptibility only.

Test Environment

In order to carry out these tests the SPIRE instruments expects the CQM test environment to be as follows:

- The cryostat will give flight representative temperatures at thermal interfaces.
- Under nominal conditions it is expected that the cryostat will have a large gas flow with the CVW at ambient temperature – the heat lift will therefore be greater than expected in space. A configuration should be made possible to allow a gas flow nearer to that expected in-flight.
- The cryostat shields will be warmer – possibly much warmer than flight.
- The thermal radiation environment will not be representative without some GSE in place. Notably the cryostat lid will be at a minimum of ~300 K
- A configuration with the final radiation shield blanked off is being considered – this will give a lower background than expected in space.
- A representative telecommanding and data handling environment will be provided by the Prime Contractor/ESA and the Instrument will provide a quick look facility.

The nominal on-ground orientations of the SPIRE test cryostat, and of the HOB when the HPLM is aligned in the vertical position, are such that the SPIRE FTS mechanism cannot be operated.

For correct operation of the FTS, the SOB - which lies in the X-Z plane of the HPLM coordinate system - must be rotated by either +90° or -90° about the Z axis. This would be achieved by rotating the complete HPLM by ±90° about the Z axis.

Similarly, correct recycling of the SPIRE 0.3K He3 cooler requires that the HPLM be tilted around the Z axis by an angle θ such that $+20^\circ \leq \theta \leq +160^\circ$.

This will ensure that, for recycling, the cooler evaporator lies below the cooler pump, thereby avoiding the adverse convection effects which can occur if the (colder) evaporator lies near-horizontally or above the (warmer) pump.

Note : according IHDR, minimum goal tilt angle required by the cooler is 30° (against 20°) and maximum tilt is 25° in TV Test.

Detailed Sequencing

Sequence	Duration [days]	Objective	Requirements	Remarks
Instrument Test SPIRE	3			
SPIRE Functional Test	~1.5			
1		SPIRE switch on procedure, including validation of connection between EGSE and instrument, memory load and dump		SPIRE will be switched to the ON mode
2		Validate function of HSDPU		At the end of this SPIRE will be switched to REDY mode
3		Validate function of HSDRCU		
4		Verify function of cooler thermistors and heaters		
5		Verify function of mechanisms BSM; FTS - see note)	To operate the SPIRE FTS mechanism the cryostat will need to be tilted over to 90 degrees about the Z axis.	
6		Cooler recycle	To recycle the SPIRE cooler the cryostat will need to be rotated about the Z-axis by at least 17 degrees	
7		Verify function of bolometers, detector readouts, thermal control heaters and temperature sensors		To do this properly will require either the use of the PLM GSE; blanking the final shield within the cryostat
8		Verify function of Calibration sources		
9		Verify SPIRE Autonomy functions		
10		Verify SPIRE to CDMS interfaces and telemetry rates		This to include S/C switching SPIRE to SAFE mode in event of an anomaly

Sequence	Duration [days]	Objective	Requirements	Remarks
11		Validation of SPIRE deactivation (=shut-down) procedure		SPIRE will be switched to OFF mode
SPIRE Performance Test	~1.5			
1		Validation of SPIRE activation sequence and switch to SPIRE ready Mode		Takes SPIRE from OFF to REDY
2		Cooler recycle	Cryostat needs to be orientated correctly - see above	
3		Validation of SPIRE switching to standby mode		SPIRE switched to standby
4		Switch SPIRE to photometer OBSERVE		SPIRE switched to one of the photometer observe modes and placed in most straylight sensitive condition
5		Cryostat background measurement	This requires GSE or blanked off shield	
6		EMI tests		Test for induced noise from whatever source in quiescent conditions
7		Conducted susceptibility		Inject EMC through supply lines
8		Test SPIRE HSFPU thermal behaviour in photometer observe mode		Run through typical photometer observing sequence in most "thermally intensive" mode - this will include operation of calibrators and BSM.
9		Switch SPIRE to spectrometer OBSERVE	Cryostat needs to be orientated correctly (see above). Test of how long it takes to switch modes.	
10		Test SPIRE HSFPU thermal behaviour in spectrometer observe mode		Run through typical spectrometer observing sequence - this will include operation of calibrators.
SPIRE AOT Test				
1		Test SPIRE photometer POFs		Details TBD - generates test data sets for interface checks with HCSS and processing software etc
2		Test SPIRE spectrometer POFs		Ditto
SPIRE/PACS parallel Operation				
1		SPIRE switched to standby mode PACS as prime instrument		Details TBD
SPIRE Shutdown				

Sequence	Duration [days]	Objective	Requirements	Remarks
1		SPIRE switched from standby to OFF		If all tests are done contiguously then this only need happen once. If not then will need to have appropriate shut down and start up sequences at the beginning of each test period.

Table 7.2-1: Outline test sequence for the SPIRE CQM integrated in the CQM PLM.

7.2.2 PFM Testing

The PFM system level test procedures for SPIRE are TBW. It is expected that they will be for instrument and system verification and validation purposes only as the CQM testing will have addressed all fundamental operational issues. The sequencing and test environment requirements for the PFM testing will be the same, or very similar (TBC), as for the CQM testing shown in table 7.2-1.

7.2.3 Thermal on ground Test

See table 5.7-2 in section 5.7.1.3

7.3 Operations

Covered in other applicable documentation as follows:

- AD 3 Herschel/Planck Operations Interface Requirements Document (OIRD)
- AD 4 Herschel Science-operations Implementation Requirements Document (Herschel-SIRD)

7.4 Commonality

The SPIRE system level integration and test programme is compatible with that laid out in the IID-A chapter 7.

8. PRODUCT ASSURANCE

The instrument will comply with the 'Product Assurance Requirements for Herschel/Planck Scientific Instruments' (AD2).

Details are to be found in SPIRE Product Assurance Plan (RD7).

9. DEVELOPMENT AND VERIFICATION

9.1 General

These are guidelines that will be followed in constructing the instrument AIV programme:

- The instrument will be fully tested in compliance with the satellite level AIV plans as set out in the IID part A and reference documents therein.
- The AIV flow will be designed to allow the experience gained on each model to be fed into both the design and construction of the next model and into the AIV procedures to be followed for the next model.
- A cold test facility to house the instrument will be constructed that will represent as nearly as possible the conditions and interfaces within the Herschel cryostat.
- The instrument Quick Look Facility and commanding environment will be the same or accurately simulate the in-flight environment to facilitate the re-use of test command scripts and data analysis tools during in-flight operations.
- The EGSE and instrument Quick Look Facility will interface to HCSS.
- Personnel from the ICC will be used to conduct the instrument functional checkout to allow an early experience of the instrument operations and to facilitate the transfer of expertise from the ground test team to the in-flight operations team.
- A more detailed description of the system level AIV sequence is given in reference document RD4. This document will form the basis of the *Herschel SPIRE Instrument Test Plan*, which will provide the baseline instrument test plans and detailed procedures and will be submitted to ESA for approval.
- Detailed procedures for the sub-system level AIV will be produced by all sub-system responsible groups.
- Sub-systems will undergo individual qualification or acceptance programmes before integration into the instrument.
- Sub-systems will be operationally and functionally checked at the appropriate level before integration into the instrument.

9.2 Model Philosophy

The model philosophy to be adopted for the AIV of the SPIRE instrument will be in accordance with the requirements of the Herschel IID part A. The instrument models to be produced are:

- AVM - Avionics Model.
- CQM - Cryogenic Qualification Model.
- PFM - Proto Flight Model.
- FS - Flight Spare.

See section 5.16.1 for more details

Note: section 9.2 to be updated by SPIRE according new model philosophy

9.3 Mechanical Verification

TBD . Text to be provided by SPIRE

9.4 Thermal Verification

TBD. Text to be provided by SPIRE

9.5 Verification of Scientific Performance

TBD. Text to be provided by SPIRE

9.6 Electrical Testing

TBD. Text to be provided by SPIRE

9.7 EMC Testing

TBD. Text to be provided by SPIRE

10. MANAGEMENT, PROGRAMME, SCHEDULE

All relevant information can be found in the SPIRE Management Plan, RD4.

SPIRE IIDB Issue 3.2 - ANNEX

Annex 1

SPIRE units ICD

ICD issue 8 drawings configuration and Industry comments

&

SPIRE-RAL-DWG-001409 - Issue 8 - December 2003

SPIRE IIDB Issue 3.2 - ANNEX

Annex 1-1

ICD issue 8 drawings configuration and Industry comments

SPIRE Unit	SPIRE CR (*)	Drawing ref/number	Issue	Date	Notes & Comments
DPU	040 v2	HER S005/03	4	23-02-03	
DCU	040 v2	SPIR-MX-5100 000	D	XX-10-02	
FCU	040 v2	SPIR-MX-5200 000	F	XX-10-02	(1) FCU shall use M5 feet. Surface contact of about 500 cm ² foreseen. SPIRE to issue new CR and drawing
DCU QM1 (i)	New	SPIR-MX-5101 000	A	02/12/02	(2) To be discussed and agreed with industry.
FCU QM1 (i)	New	SPIR-MX-5201 000 Redlined, added comments	C	08/09/03	(2) To be discussed and agreed with industry.
FPU (i) (SPIRE IF)	New	A1 5264 300 sheets 1 to 7	18	04/07/03	(3) Issue 18 agreed according comments HP-ASED-EM-0740-03
2 JFET (i)	New	0-KE-0104-360	J	12/11/03	Issue H agreed, but issue J to be checked/agreed by industry
6 JFET (i)	New	0-KE-0104-350	G	13/10/03	Issue F agreed, but issue G to be checked/agreed by industry

(*) : last CR applied (HR-SP-RAL-ECR-) since SPIRE IIDB issue 2.2

(i): New drawings with no SPIRE CR.

Previous drawings with last SPIRE CR 040 v2 were (no existing previous drawings for DCU & FCU QM1):

	CR	Drawing ref/number	Issue	Date
FPU	040 v2	A1 5264 300 sheets 1 to 7	17	16/10/02
2 JFET	040 v2	0-KE-0104-360	H	20/05/03
6 JFET	040 v2	0-KE-0104-350	F	20/03/03

(1) : FCU feet shall use M5 feet instead of M4 as on the present drawing. A surface contact of about 500 cm² (instead of 1006 cm² on the present drawing) is foreseen. SPIRE to issue new CR and drawing

(2) : QM1 drawings to be discussed and agreed with industry: connectors number and position changes versus FM, with corresponding harness and AIT impacts. To be updated by SPIRE. All AVM/CQM units drawing still to be provided by SPIRE.

(3) : Extract of mail HP-ASED-EM-0740-03 From Horst Faas, 28/11/2003 :

Objet : HP-ASED-EM-0740-03: Check of SPIRE FPU ICD, Issue 18 - Closure of AI#6, HP-ASP-MN-3961

EADS Astrium has performed an initial review of the SPIRE FPU ICD, MSSS/SPIRE/SP005.03, Issue 18, 7/07/03, contained in SPIRE-RAL-DWG-001409, Issue 7, November 2003.

The comments raised by EADS Astrium in response to the ASP CR-0294 / ECR-040 and discussed in RAL/MSSS/ASED telecon on 1/07/03 have been incorporated in the update.

List of EADS Astrium comments:

- Change Log: Sheet 4 Described change not applicable to Sheet. Wrong reference.
- Sheet 1: Updated mass properties to be passed to Subcontractor for Mass and Thermal Dummies (MTD). Impact on MTD level tbd.
- Sheet 2 and 6: Update height of JFETs by 7.35mm in Issue 19.
- Sheet 3: Alignment cube comment. Clarify TBD in Issue 19.
- Sheet 3: Note related to Optical beam to be updated in Issue 19. Dimension shall be consistent with Beam Spreadsheet provided by SPIRE.
- Sheet 4: IF torques have been discussed (and initially agreed) with John Coker on 24/11/03 and by email exchange on 25/11. Torque of IF bolts to be specified in terms of net and running torque, i.e. 8.1Nm and tbd Nm (running torque)
- Sheet 5: Torque of L0 and L1 IF to be updated in terms of net and running torque, i.e. L1: 2.2 + 0.4Nm, L0: M4 2.2 + 0.4Nm, L0 / M4 temp. sensor: 1.5Nm + 0.4Nm

As no major issues have been identified in Issue 18, this issue could be included in the updated IID-B, considering the above comments.



SPIRE
INTERFACE DOCUMENT.

Doc #: SPIRE-RAL-DWG-001409
Issue: 8
Date: December 2003
Page 1 of 19

Forms Annex 1 to SCI-PT-IIDB/SPIRE-02124

Subject: SPIRE MECHANICAL INTERFACE DRAWINGS

PREPARED BY: J. DELDERFIELD  *John Delderfield* 2003.12.03
..15:56:44 Z

APPROVED BY: ERIC SAWYER pp M.GRIFFIN..... Date:



SPIRE
INTERFACE DOCUMENT.

Doc #: SPIRE-RAL-DWG-001409
Issue: 8
Date: December 2003
Page 2 of 19

Issue Drawing Change List

The detailed changes for each drawing are shown just before the drawing.

- Issue 2. Update to status as of 8th October 2002
- Issue 3 Update to status as of 1st November 2002
FCU, DCU & Cryogenic ICDs changed, see changelists where provided
- Issue 4 Update to status as of 24/2/03. JFET drawing versions raised.
- Issue 5 Updated as to status of 27th March 2003. Non-AVM DPU ICD included. JFET ICDs updated.
- Issue 6 Small errors on JFET ICDs fixed.
- Issue 7 New versions of FPU and JFET ICDs, see their individual changelists.
- Issue 8. DRCU "QM1" I/F drawings added, red-lined with NCR information. 2Module JFET updated
but changes are all internal to unit.

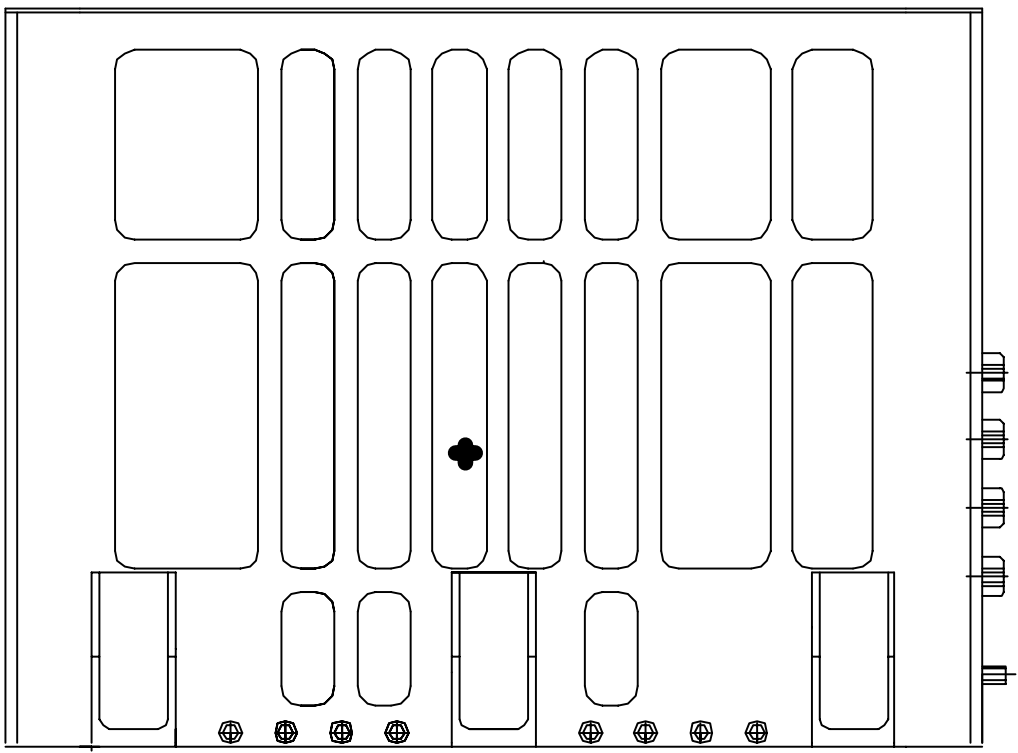
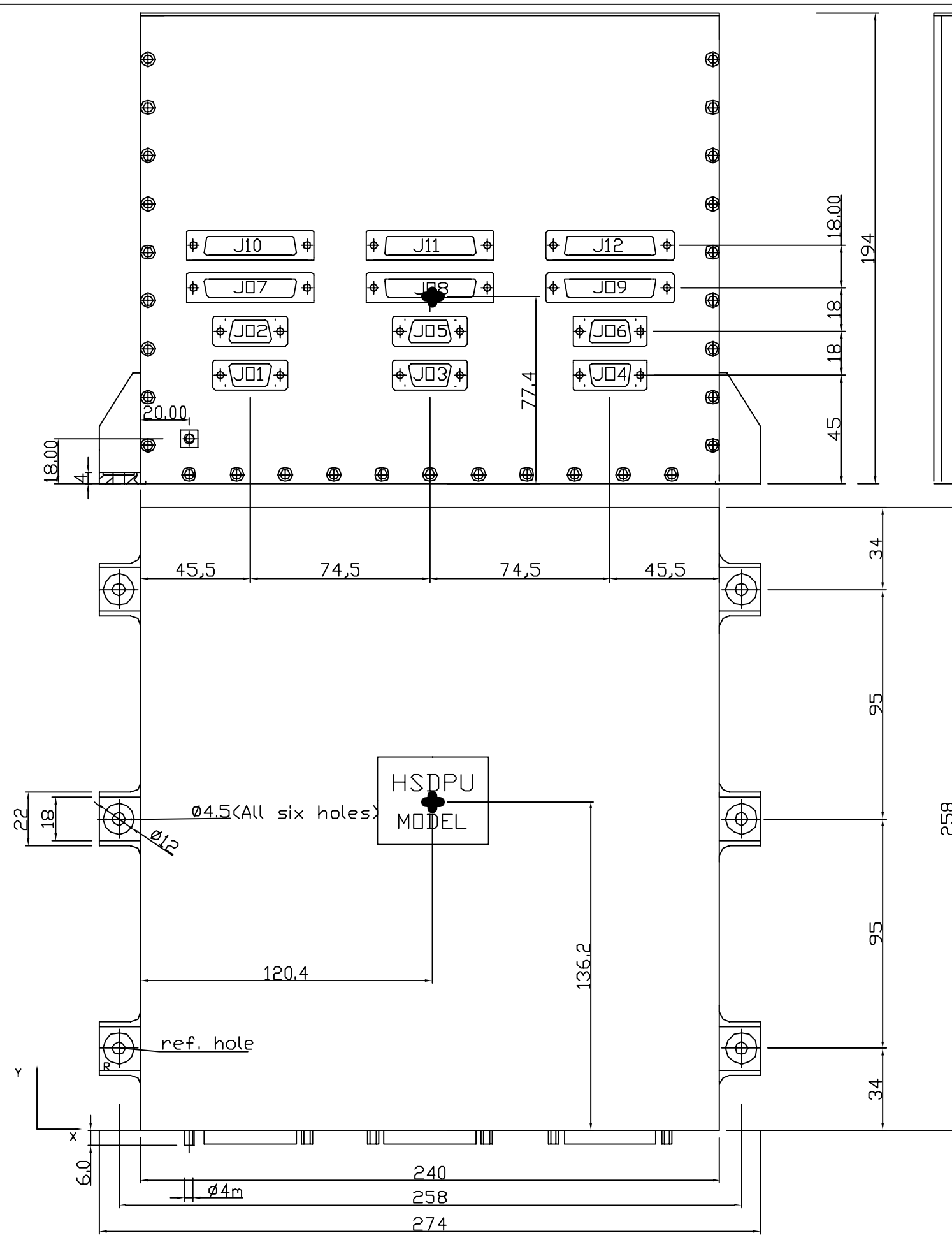

GENERAL TOLERANCE ± 1 mm
 WEIGHT 7.177 Kg ± 200 g
 DIMENSION 274 X 258 X 194mm
 CENTRE OF GRAVITY (E): X=120,4; Y=136,2;
 Z=77,4
 MOMENT OF INERTIA (E): Jx=6,23X10⁻² Kg^m²
 Jy=5,73X10⁻² Kg^m²
 Jz=7,70X10⁻² Kg^m²

CASING MATERIAL: ANTICORROSIONAL 6082
 SURFACE TREATMENT: ALODINE 1200:
 alfa solar = 0,604
 R-solar = 0,396
 epsilon IR = 0,172
 R-IR = 0,828

THERMAL CAPACITANCE: 7.177J/°C (E)
 CONTACT AREA OF BASEPLATE PLUS FEET 64428mm²
 FLATNESS OF MOUNTING AREA: 0.1mm/100mm
 CONNECTORS:

- J01= DEMA-9P From DPU Prime to PDU Prime
- J02= DEMA-9P From DPU Red. to PDU Red.
- J03= DEMA-9S From DPU Prime to Bus A Prime
- J04= DEMA-9S From DPU Prime to Bus B Prime
- J05= DEMA-9S From DPU Red. to Bus A Red.
- J06= DEMA-9S From DPU Red. to Bus B Red.
- J07= DBMA-25P From DPU Prime to DCE Prime
- J10= DBMA-25P From DPU Red. to DCE Red.
- J08= DBMA-25P From DPU Prime to MCE Prime
- J11= DBMA-25P From DPU Red. to MCE Red.
- J09= DBMA-25P From DPU Prime to SCE Prime
- J12= DBMA-25P From DPU Red. to SCE Red.

UPDATED: 23/02/2003 P. Baldetti (rev. 4)
 UPDATED: 10/02/2002 P. Baldetti (rev. 3)
 UPDATED: 16/01/2002 P. Baldetti UPDATED: 29/01/2002 P. Baldetti

Consiglio Nazionale delle Ricerche ISTITUTO di FISICA dello SPAZIO INTERPLANETARIO Via del Fosso del Mulino n.100 tel. 06/4993 fax 06/49934383	data 5/04/2001	prog. Baldetti	dis.
	scala	materiale	
	tratt.	Progetto: HERSCHEL- HSDPU	
	toll. rev. 4 data 23/02/03	titolo: HSDPU N.dis HER S005/03	

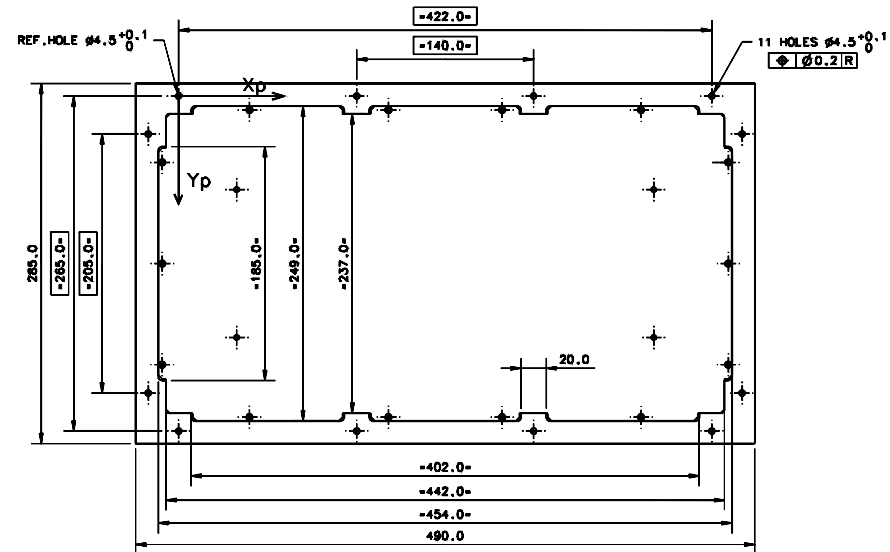
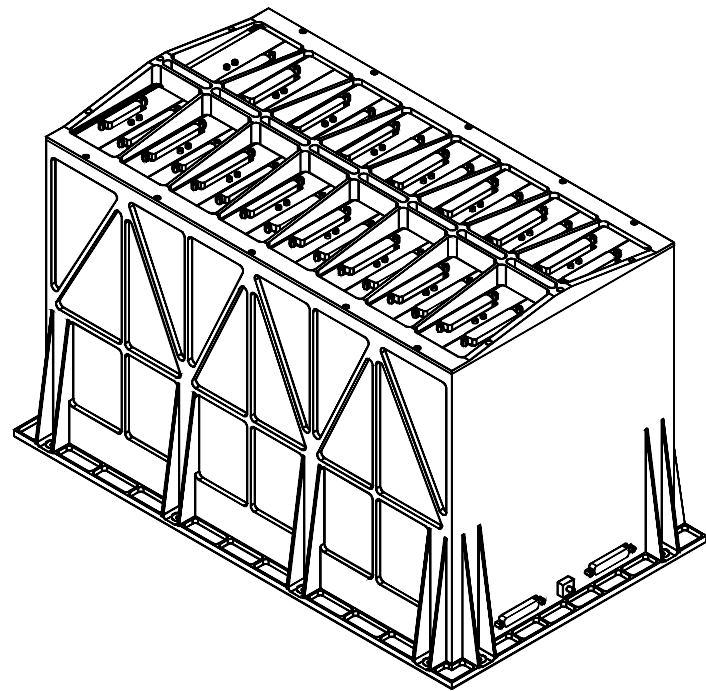

CONNECTORS					
IDENT	TYPE	FUNCTIONS	IDENT	TYPE	FUNCTIONS
J01	DBMA 25S	DAQ_IF_M/DPU_M	J17	DDMA 50P	LIA_P_7/FPU
J02	DBMA 25S	DAQ_IF_R/DPU_R	J18	DDMA 50P	LIA_P_7/FPU
J03	DBMA 25P	DCU/PSU_M	J19	DDMA 50P	LIA_P_8/FPU
J04	DBMA 25P	DCU/PSU_R	J20	DDMA 50P	LIA_P_8/FPU
J05	DDMA 50P	LIA_P_1/FPU	J21	DDMA 50P	LIA_P_9/FPU
J06	DDMA 50P	LIA_P_1/FPU	J22	DDMA 50P	LIA_P_9/FPU
J07	DDMA 50P	LIA_P_2/FPU	J23	DCMA 37P	LIA_S_1/FPU
J08	DDMA 50P	LIA_P_2/FPU	J24	DCMA 37P	LIA_S_1/FPU
J09	DDMA 50P	LIA_P_3/FPU	J25	DCMA 37P	LIA_S_2/FPU
J10	DDMA 50P	LIA_P_3/FPU	J26	DCMA 37P	LIA_S_2/FPU
J11	DDMA 50P	LIA_P_4/FPU	J27	DCMA 37P	LIA_S_3/FPU
J12	DDMA 50P	LIA_P_4/FPU	J28	DCMA 37P	LIA_S_3/FPU
J13	DDMA 50P	LIA_P_5/FPU	J29	DDMA 78S	BIAS_M/FPU
J14	DDMA 50P	LIA_P_5/FPU	J30	DDMA 78S	BIAS_R/FPU
J15	DDMA 50P	LIA_P_6/FPU	J31	DCMA 37S	BIAS_M/FPU
J16	DDMA 50P	LIA_P_6/FPU	J32	DCMA 37S	BIAS_R/FPU

NOTES

MATERIAL AL 6082

CENTRE OF GRAVITY REFERRED TO REFERENCE HOLE
 X=213.2mm Y=132.4mm Z=157.9mm

MOMENTS OF INERTIA REFERRED TO CENTRE OF GRAVITY
 Jxp=4.71 N,m2 Jyp=2.50 N,m2 Jzp=4.44 N,m2

CONTACT AREA MOUNTING FEET=28180mm2

THERMAL COATING AND BLACK ANODISING ESA.PSS.703

SURFACE EMISSIVITY >0.85

TORQUE VALUE FOR CONNECTOR FIXATION SCREWS-
 - MALE=0.3mN
 - FEMALE=0.45mN

SPECIFIC HEAT 1170 J/Kg.*K

ESTIMATED MASS=15676g

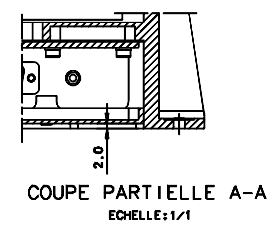
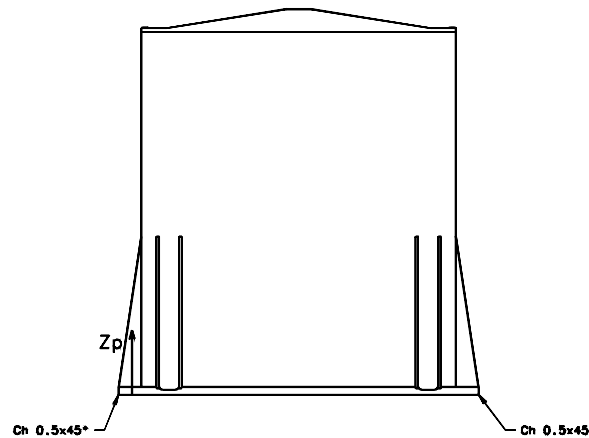
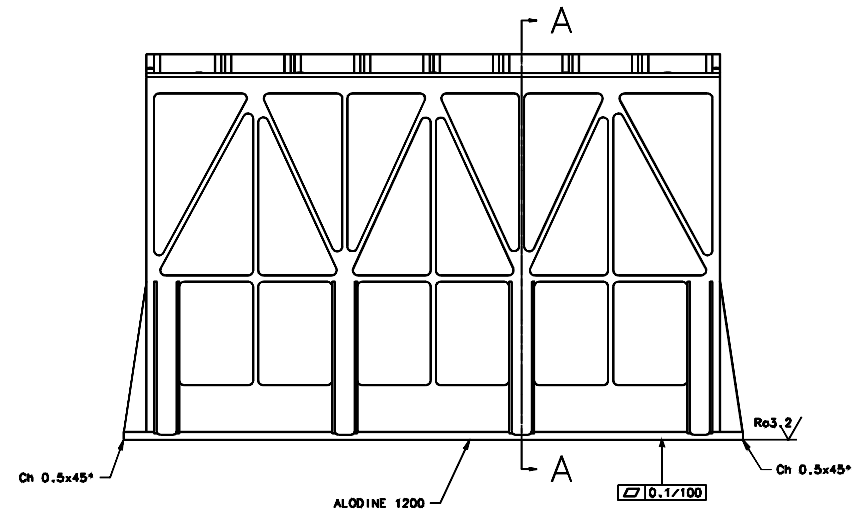
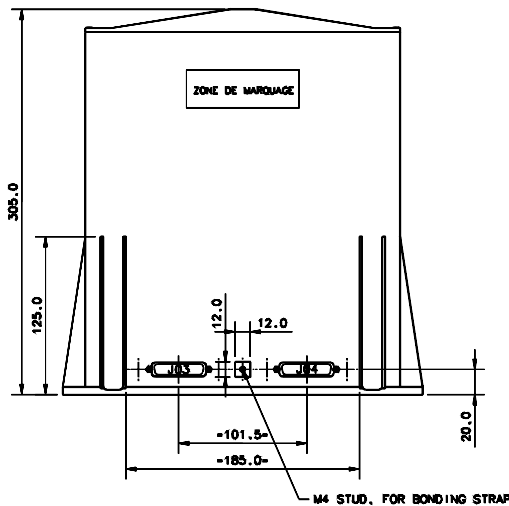

COUPE PARTIELLE A-A
 ECHELLE:1/1

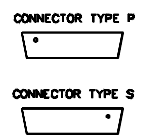

D	Ajout coupe A-A	10/02	DREMAIN		
C	Mise à jour	09/02	DREMAIN		
B	Mise à jour	06/02	DREMAIN		
A	Origine	11/01	DREMAIN		
Index	Modifications	Date	Dessiné par	Vérifié par	Approuvé par
Spécifications particulières					
Tolérances générales		Indice de rugosité général xxx	SOUS-TRAITANT		
		Tol. org. :xxx			
		Coasser les angles vifs			
Matière:			Protection		
Traitement thermique:			Echelle	Poids	Niveau qualité
			1/2		
SPIRE HSDCU ELECTRONIC BOX MECHANICAL INTERFACE CONTROL DRAWING					
11 s'est permis d'utiliser ce dessin qu'avec l'autorisation écrite de l'Etat du 11 mars 1987					
SAP/GERES		COMMISSARIAT A L'ENERGIE ATOMIQUE		C.E.N. SACLAY	
Tel:01.69.08.78.25					
01.69.08.59.78					
Fax:01.69.08.79.96		AD		SPIR-MX-5100 000 D	

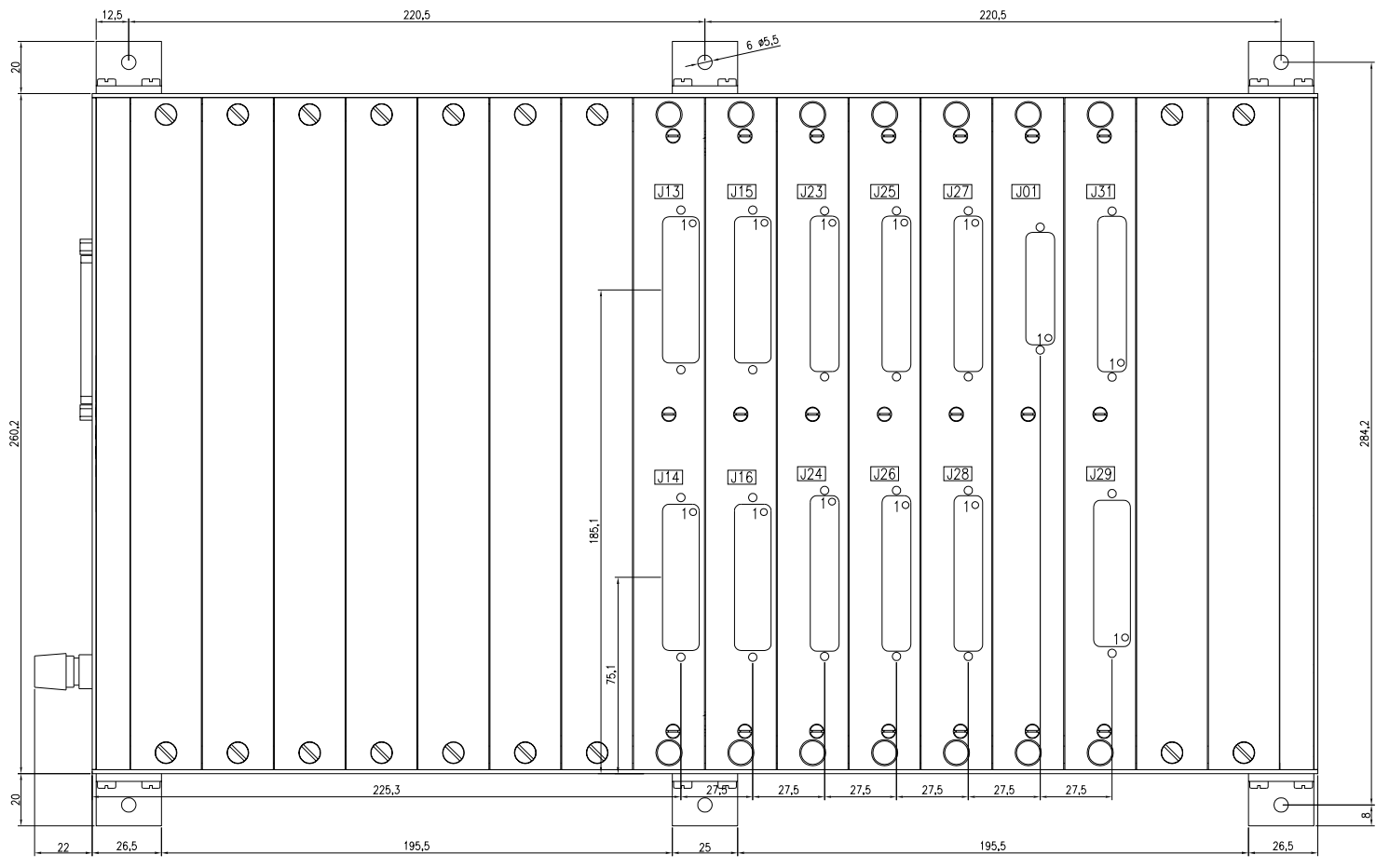
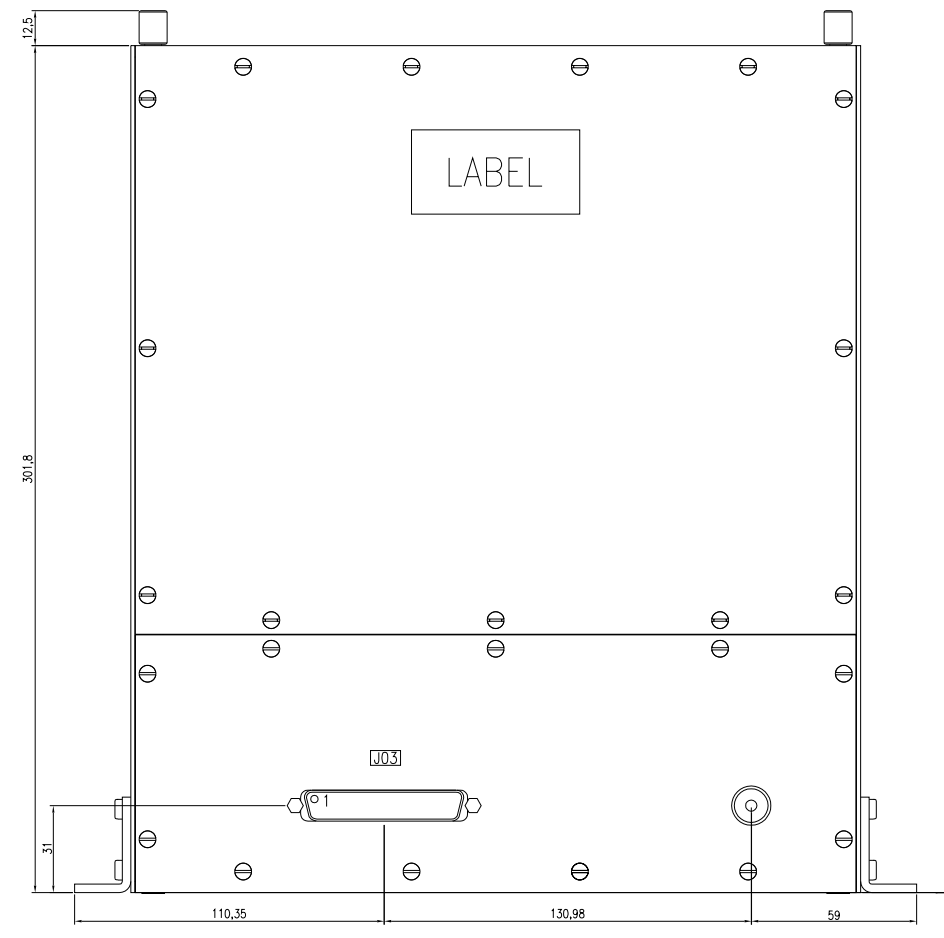
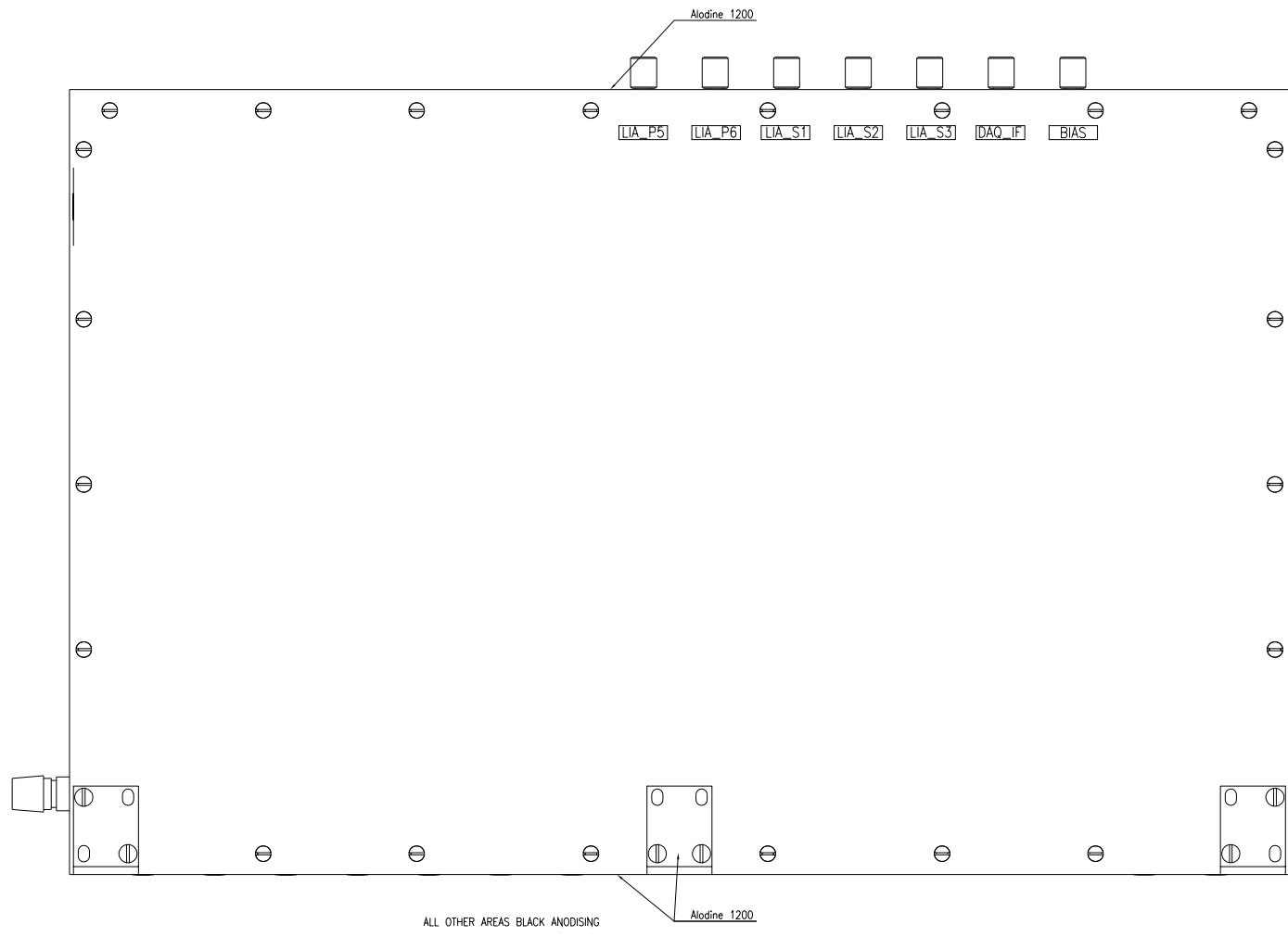

CONNECTORS					
IDENT	TYPE	FUNCTION	IDENT	TYPE	FUNCTION
J01	DBMA 25S	DAO_IF_M/DPU	J24	DCMA 37P	LIA_S_1/FPU
J03	DBMA 25P	DCU/PSU_M	J25	DCMA 37P	LIA_S_2/FPU
J13	DDMA 50P	LIA_P_5/FPU	J26	DCMA 37P	LIA_S_2/FPU
J14	DDMA 50P	LIA_P_5/FPU	J27	DCMA 37P	LIA_S_3/FPU
J15	DDMA 50P	LIA_P_6/FPU	J28	DCMA 37P	LIA_S_3/FPU
J16	DDMA 50P	LIA_P_6/FPU	J29	DDMA 78S	BIAS_M/FPU
J23	DCMA 37P	LIA_S_1/FPU	J31	DCMA 37S	BIAS_M/FPU

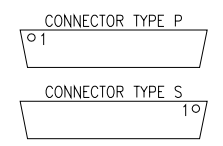

ONLY FOR QM1

CEA /SAP 91191 GIF/YVETTE Cedex		MATIERE : Alu 2017A	PROTECTION :
TRAITEMENT : Alodine 1200		DESSINE : SREE	DATE : 02/12/02
VERIFIE :		VISA :	
CE DOCUMENT EST LA PROPRIETE DE LA SOCIETE C.E.A. ET NE PEUT ETRE REPRODUIT OU COMMUNIQUE SANS AUTORISATION ECRITE			
ECHELLE : 3/4	TOLERANCES GENERALES : ±0.2	Ro1.6	
DESIGNATION ICD HS DCU/QM1	SRIR-MX-5101 000 A		0 A1

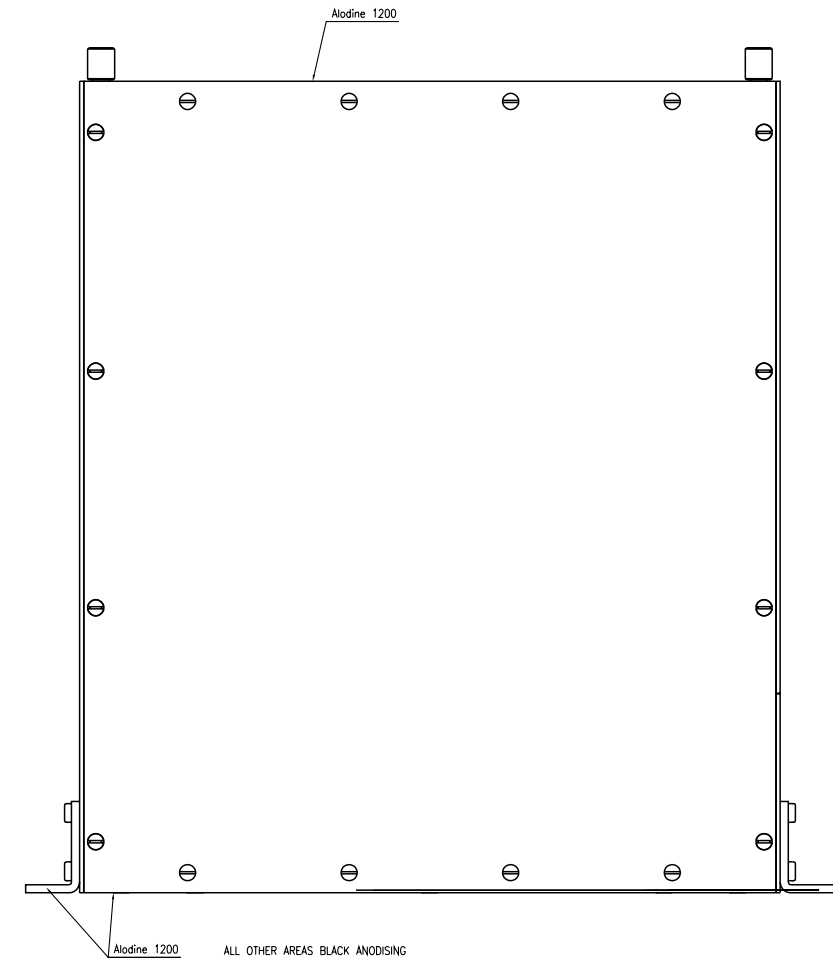
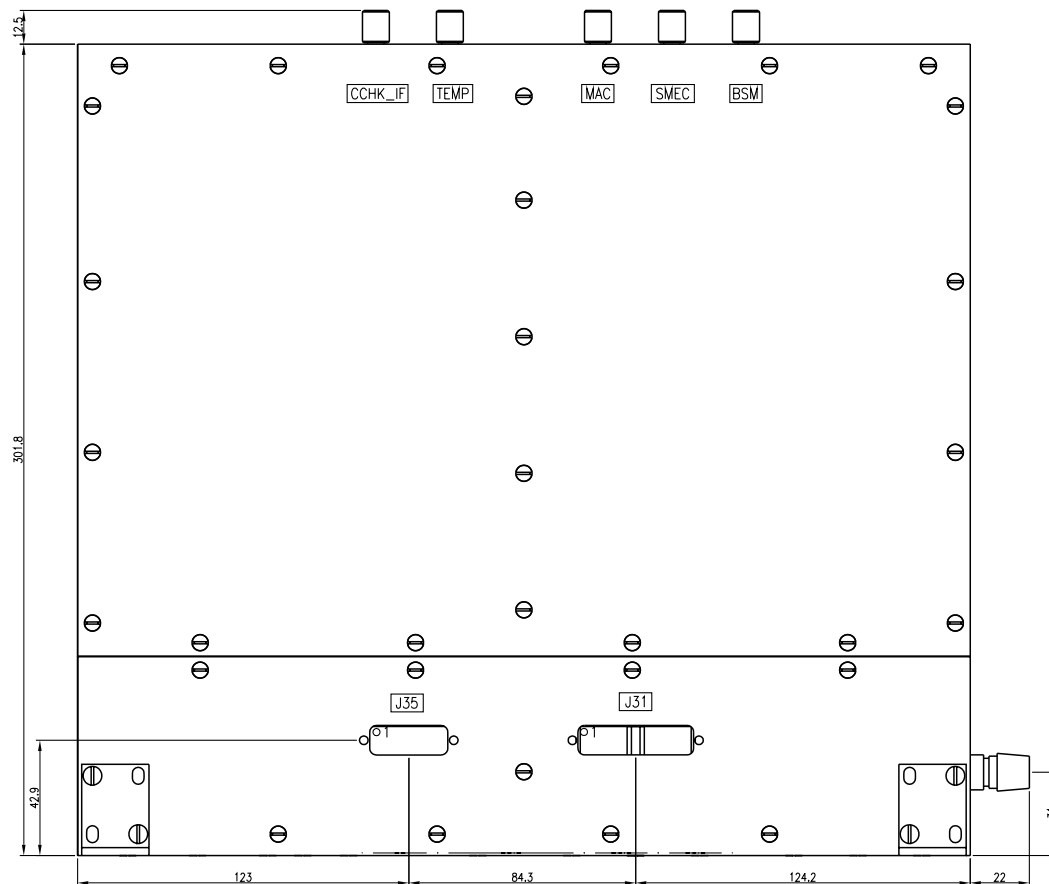
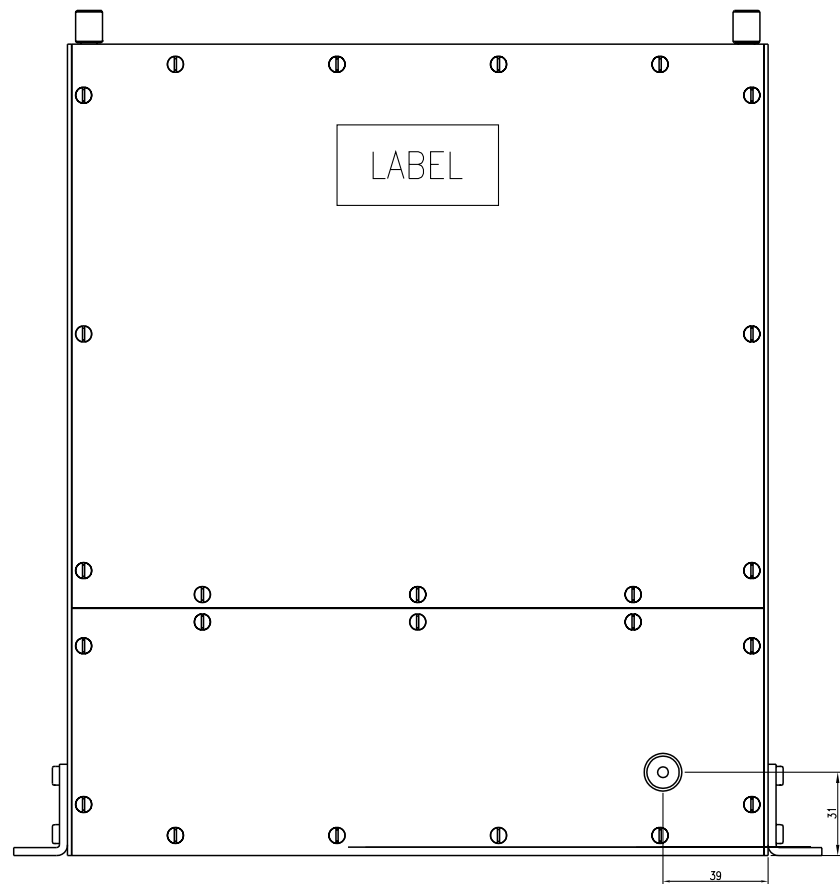

Change History:

Version C comes as part of the QM1 ADP
There's no change list; modules are reordered

In this version C of QM1, and indeed in B, J01 is in the same position within its module as is shown on the latest FM drwg. So J01 is drawn in the same position in its module in all three drawings.

However, NCR_MCU_#105.pdf says that J01 is in J39's position and vice versa, so this is shown in red to the right.

NCR_MCU_#104.pdf also notes unspecific discrepancies, but this issue C is said to discharge NCR 104 by showing all the variations.

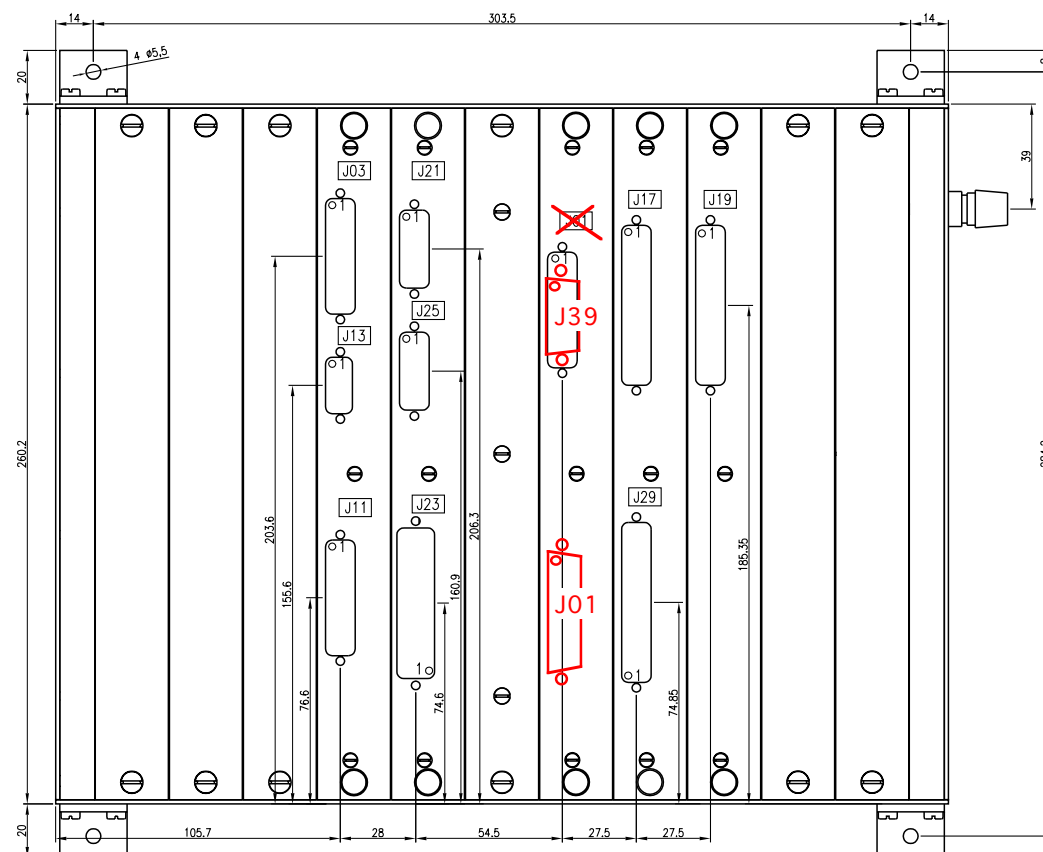

CONNECTORS					
IDENT	TYPE	FUNCTION	IDENT	TYPE	FUNCTION
J01	DBMA 25S	MAC/DPU	J21	DAMA 15S	TEMP/FPU-TS-1
J03	DBMA 25S	CCHK-IF/DPU	J23	DDMA 50S	TEMP/FPU-TS-2
J11	DBMA 25S	CCHK-IF/FPU-COOL-CAL	J25	DAMA 15S	TEMP/FPU-MEC-TS
J13	DCMA 9S	CCHK-IF/FPU-PH-STIM	J29	DCMA 37P	SMEC/FPU-SMECm-2
J17	DCMA 37S	SMEC/FPU-SMECm-1	J31	DBMA 25P	MCU/PSU
J19	DCMA 37S	BSM/FPU-BSM	J35	DAMA 15P	SCU/PSU

CEA /SAP 91191 GIF/YVETTE Cedex	MATIERE : Alu 2017A	PROTECTION :
	TRAITEMENT : ALODINE 1200	DESSINE : SREE DATE : 08/09/03
CE DOCUMENT EST LA PROPRIETE DE LA SOCIETE C.E.A. ET NE PEUT ETRE REPRODUIT OU COMMUNIQUE SANS AUTORISATION ECRITE		VERIFIE : VISA :
DESIGNATION ICD HS FCU/QM1	ECHELLE : 3/4	TOLERANCES GENERALES : ±0.2
SPIR-MX-5201 000 C		Ra1,6

USED ON
HERSCHEL

DRAWING No.
A1 5264 300sht 1

THIRD ANGLE PROJECTION

DO NOT SCALE

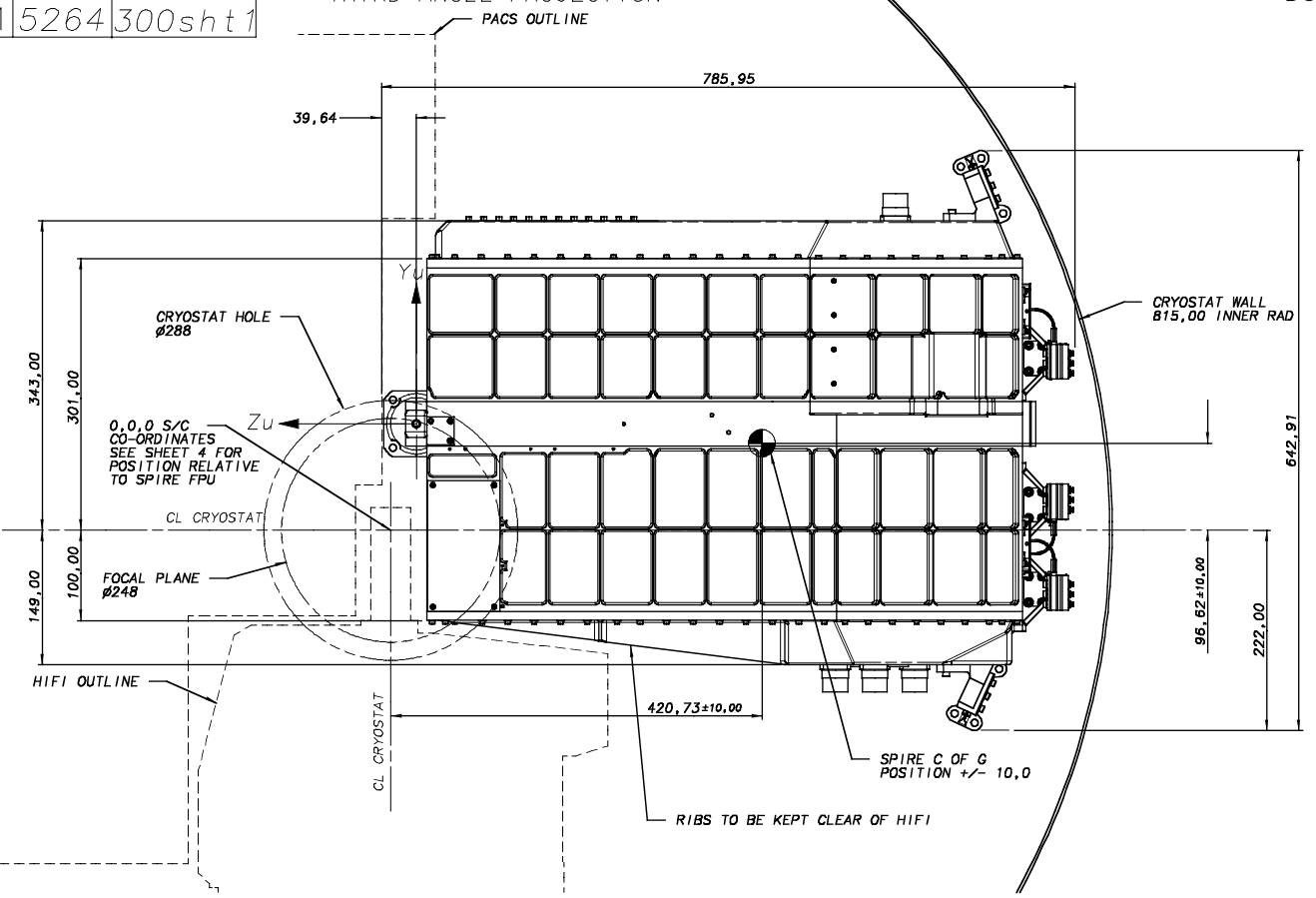

NOTE:-
 1. ALL DIMENSIONS AT ROOM TEMPERATURE
 2. J-FET BOXES NOT SHOWN ON THIS SHEET

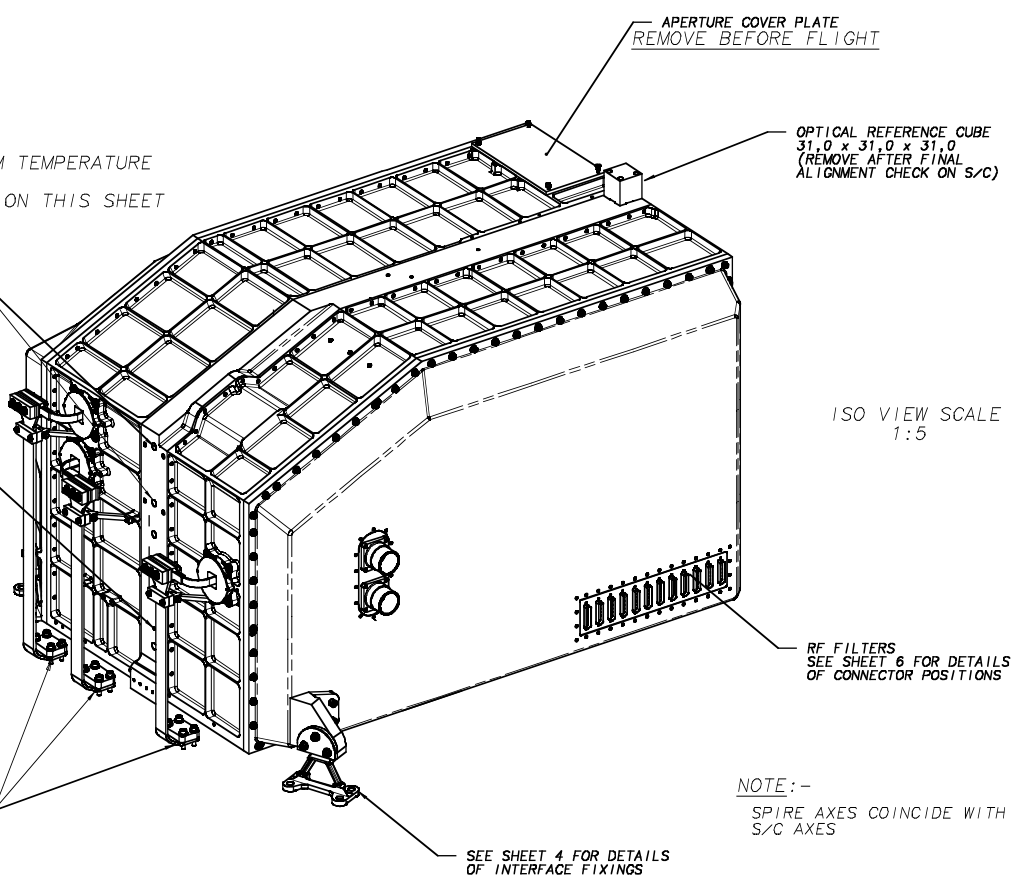

MOMENTS OF INERTIA ABOUT CG:-
 (NOTE:- ALL MASS PROPERTIES EXCLUDE JFETS, AND EXTERNAL FPU HARNESSSES)
 $I_{xx} = 2,929 \text{ kg m}^2$
 $I_{yy} = 2,878 \text{ kg m}^2$
 $I_{zz} = 1,548 \text{ kg m}^2$
 (MASS 45,63 kg)

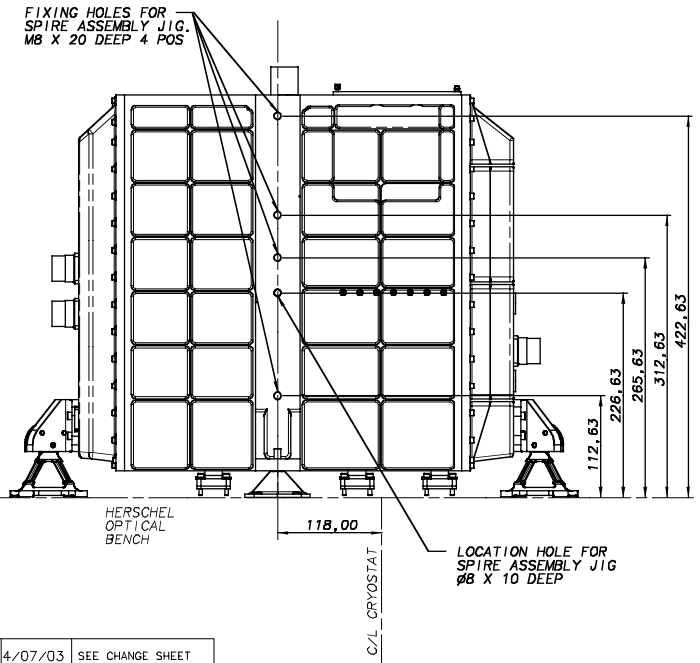

IMPORTANT :-
 MINIMUM CLEARANCE BETWEEN ANY PART OF SPIRE FPU AND CRYOSTAT INNER SHIELD TO BE 10mm (8,9mm ACCEPTED AT -Z/+Y FPU CORNER ONLY)

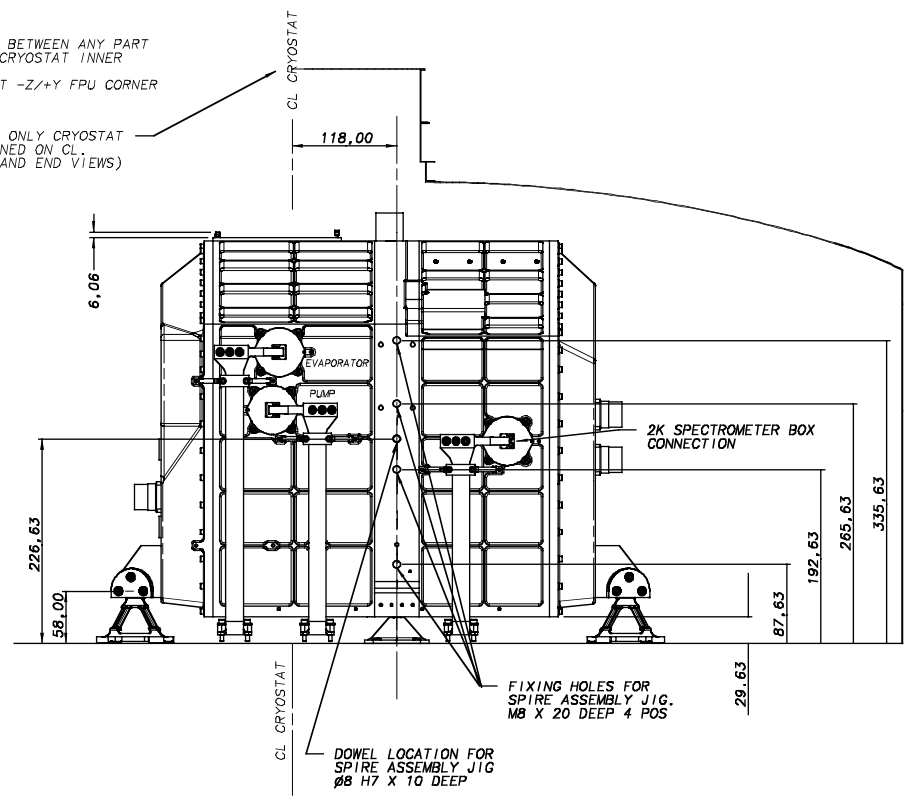
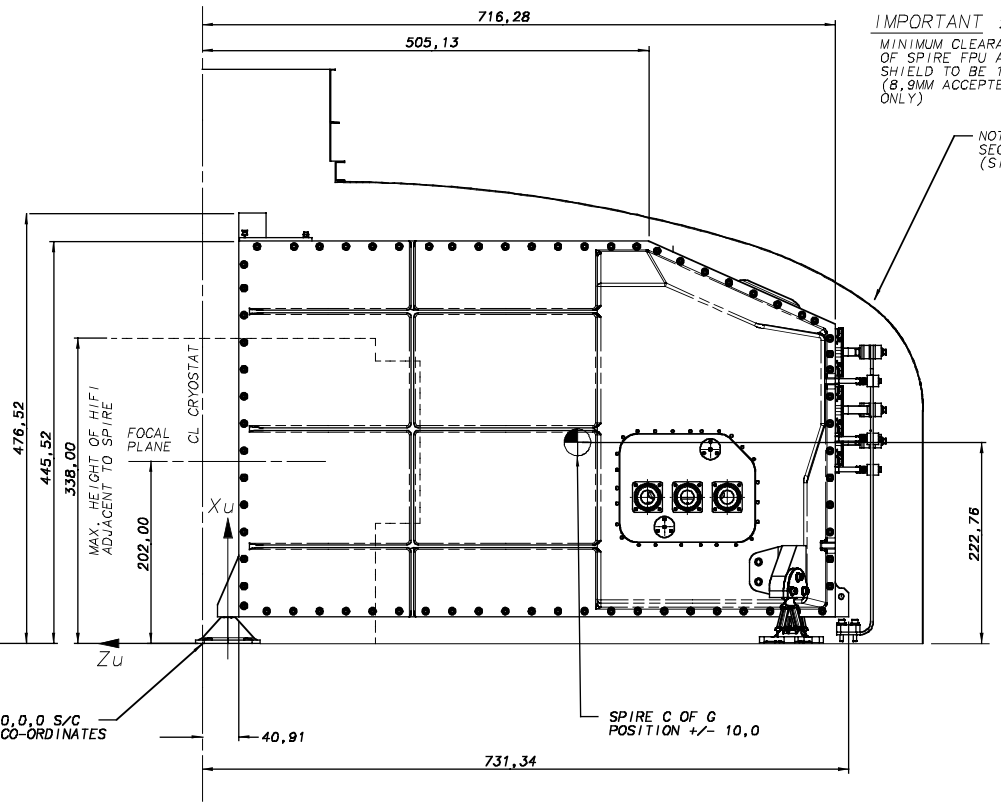

18	4/07/03	SEE CHANGE SHEET	
17	16/10/02	SEE CHANGE SHEET	
CHECKED	16	28/08/02	MODIFICATIONS AND CHANGE SHEET CREATED. DRAWING UPDATED TO ISSUE 16 THERE-ON.
	15	27/04/01	THERMAL STRAP INTERFACE MODIFIED. LEVEL 1 STRAP FIXING HOLES MOVED.
TRACED	14	23/11/01	CENTRE OF GRAVITY ADDED TO SHT 1. J-FET DESIGN UPDATED. STAY OUT HOLES REMOVED.
PBG	13	19/11/01	UPDATED RF1 FILTER & PHOT CONNECTORS ADDED. FOCAL PLANE & *A* FRAME MOUNT DIM ADDED. SHEET 7 ADDED.
DRAWN	ISSUE	DATE	AMENDMENT
AJC	1	24/11/01	

NOTE:-
 SEE CHANGE SHEET FOR DETAILS OF CHANGES MADE FROM ISSUE 16 ONWARDS

SPIRE Flight Assemblies
 COMPUTER FILE

PROTECTIVE FINISH ALOCROM 1200 (ST. STEEL PARTS NATURAL)	MATERIAL & SPEC. AS LISTED	TOLERANCES UNLESS OTHERWISE STATED - LINEAR \pm 1,0 ANGULAR \pm 0*15'
ESTD WT. 45,63kg (NO CONT) SEE NOTE SHT.1	DIMENSIONS IN mm	SCALE 1:4
ACTL WT.		

DEPARTMENT OF SPACE AND CLIMATE PHYSICS UNIVERSITY COLLEGE LONDON MULLARD SPACE SCIENCE LABORATORY, HOLMBURY ST. MARY, DORKING, SURREY.	
TITLE SPIRE INTERFACE (GENERAL DIMENSIONS)	DRAWING No A1 5264 300sht 1
SHEET 1 OF 7	

USED ON
HERSCHEL

DRAWING No.
A1 5264 300sht2

THIRD ANGLE PROJECTION

DO NOT SCALE

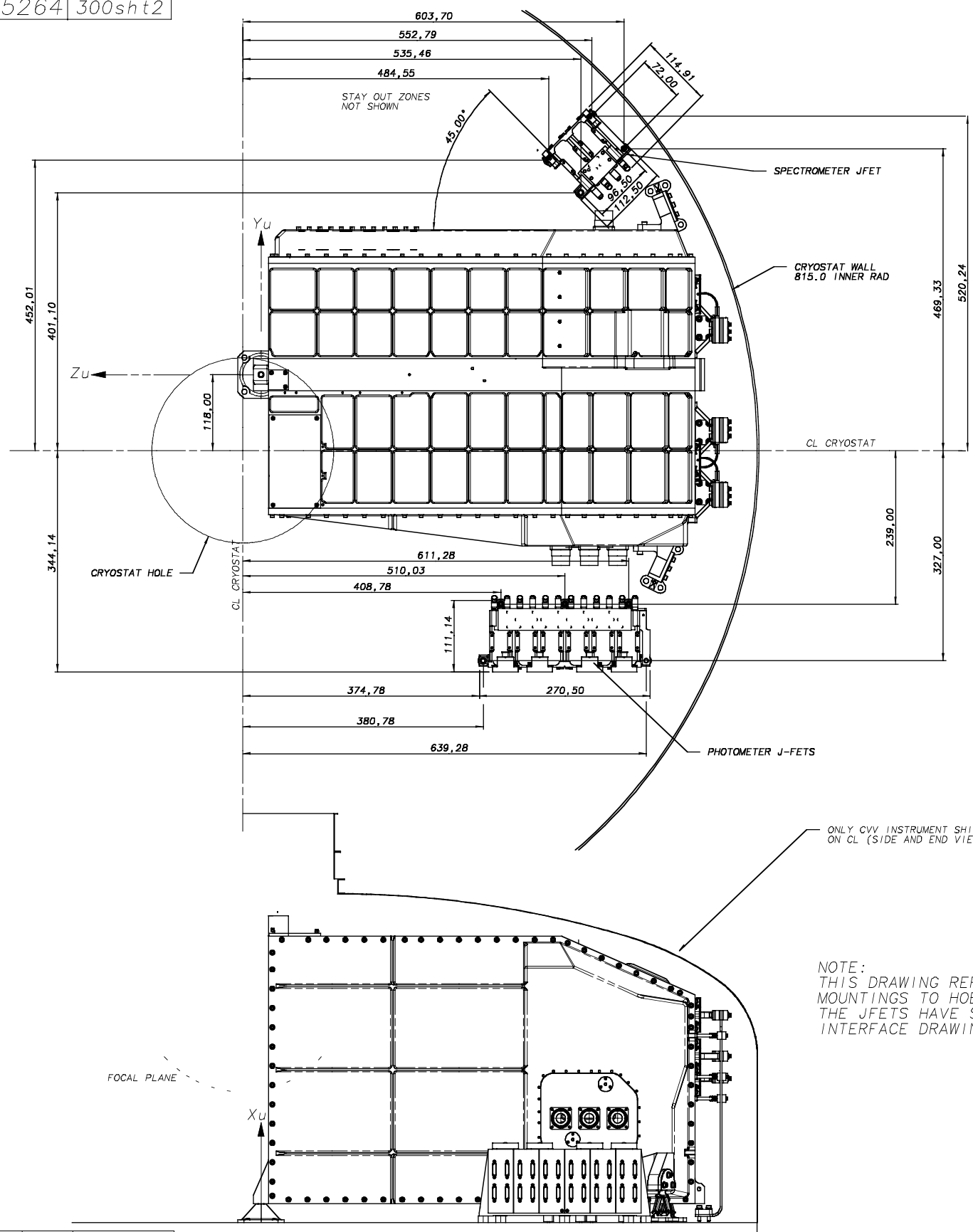

NOTE:-
1. ALL DIMENSIONS AT ROOM TEMPERATURE

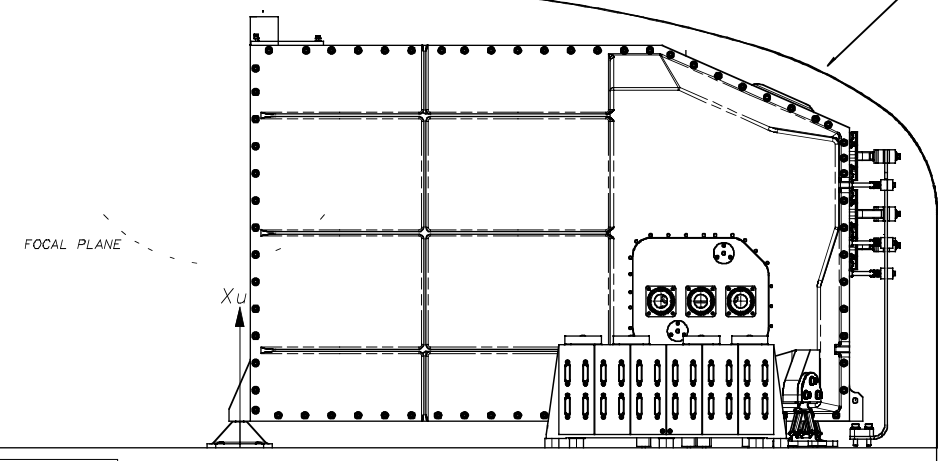
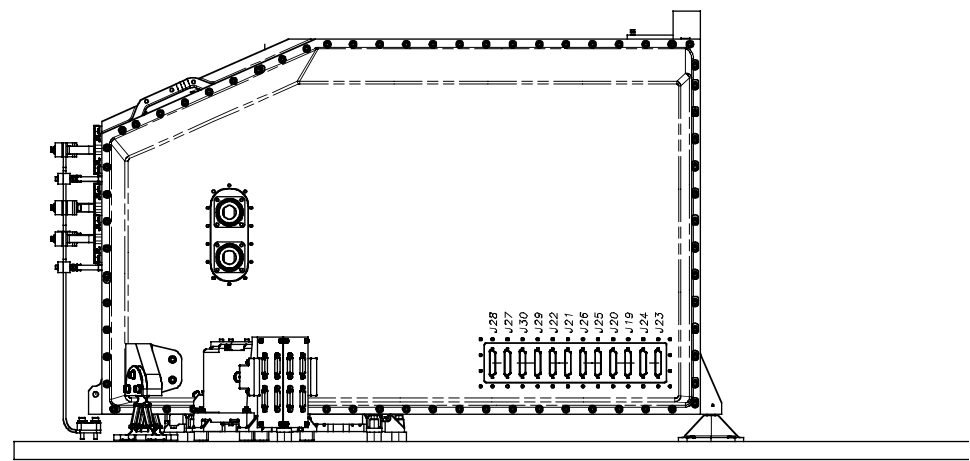

NOTE:
THIS DRAWING REFERENCES THE JFET UNIT MOUNTINGS TO HOB S/C CO-ORDINATES. THE JFETS HAVE SEPARATE DETAILED INTERFACE DRAWINGS.

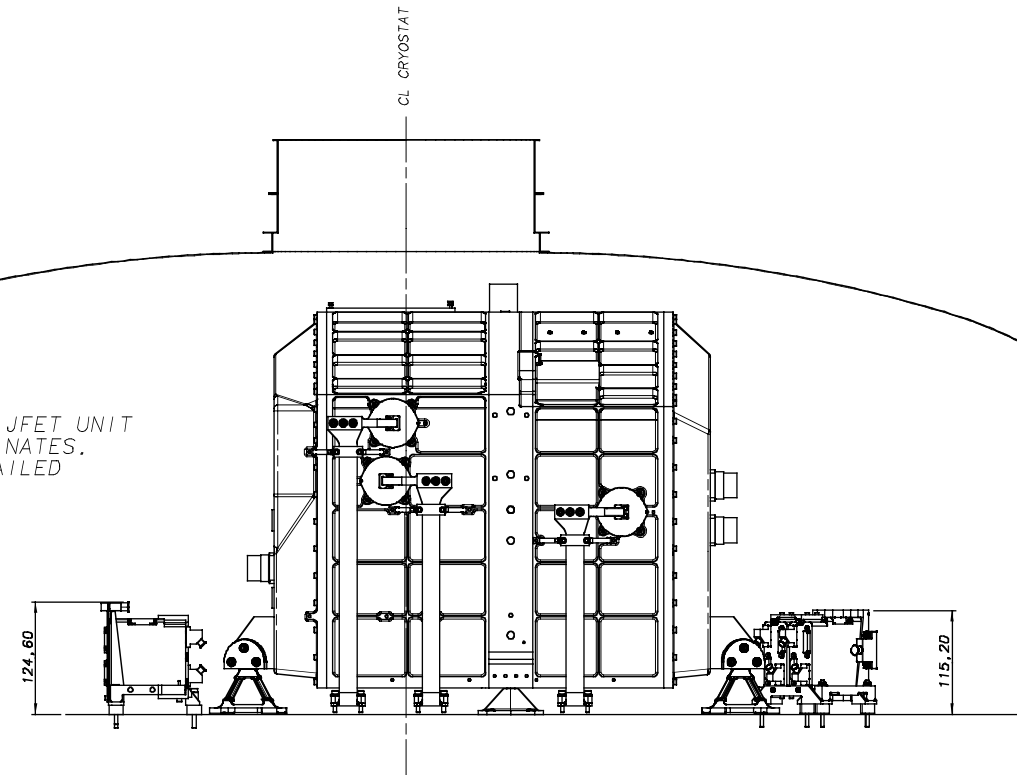

18	4/07/03	SEE CHANGE SHEET	
17	16/10/02	SEE CHANGE SHEET	
CHECKED	16	28/08/02	MODIFICATIONS AND CHANGE SHEET CREATED. DRAWING UPDATED TO ISSUE 16 THERE-ON.
	15	27/04/01	THERMAL STRAP INTERFACE MODIFIED. LEVEL 1 STRAP FIXING HOLES MOVED.
TRACED	14	23/11/01	CENTRE OF GRAVITY ADDED TO SHT 1. J-FET DESIGN UPDATED. STAY OUT HOLES REMOVED.
PBG	13	19/11/01	UPDATED RFI FILTER & PHOT CONNECTORS ADDED, FOCAL PLANE & *A* FRAME MOUNT DIM ADDED. SHEET 7 ADDED.
DRAWN	ISSUE	DATE	AMENDMENT
AJC	1	24/11/01	

PHOTOMETER SIDE
NOTE:-
SEE CHANGE SHEET FOR DETAILS OF CHANGES MADE FROM ISSUE 16 ONWARDS

SPIRE Flight Assemblies
COMPUTER FILE

PROTECTIVE FINISH ALOCROM 1200 (ST. STEEL PARTS NATURAL)	MATERIAL & SPEC. AS LISTED	TOLERANCES UNLESS OTHERWISE STATED - LINEAR +/- 1.0 ANGULAR +/- 0°15'
ESTD WT. 45,63kg(NO CONT) SEE NOTE SHT.1	DIMENSIONS IN mm	SCALE 1:4
ACTL WT.		

DEPARTMENT OF SPACE AND CLIMATE PHYSICS UNIVERSITY COLLEGE LONDON MULLARD SPACE SCIENCE LABORATORY, HOLMBURY ST. MARY, DORKING, SURREY.		DRAWING No
TITLE SPIRE INTERFACE (J-FET POSITIONS)		A1 5264 300sht2
SHEET 2 OF 7		

DRAWING No.

A1 5264 300sht3

THIRD ANGLE PROJECTION

DO NOT SCALE

USED ON
HERSCHEL

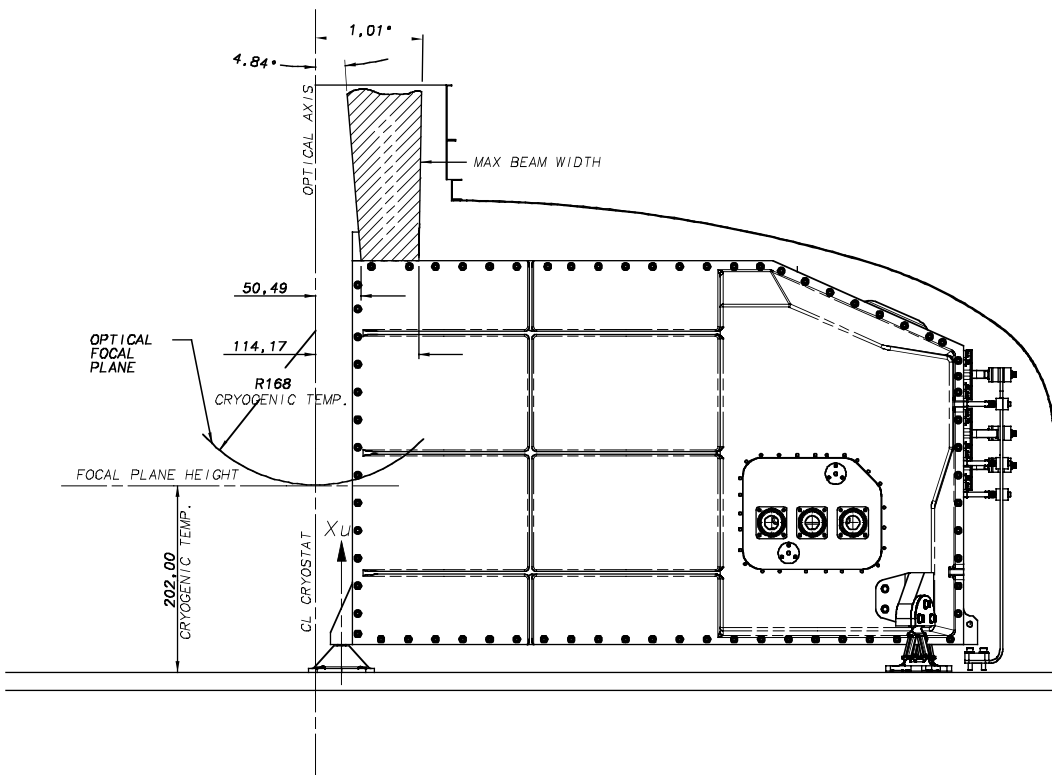
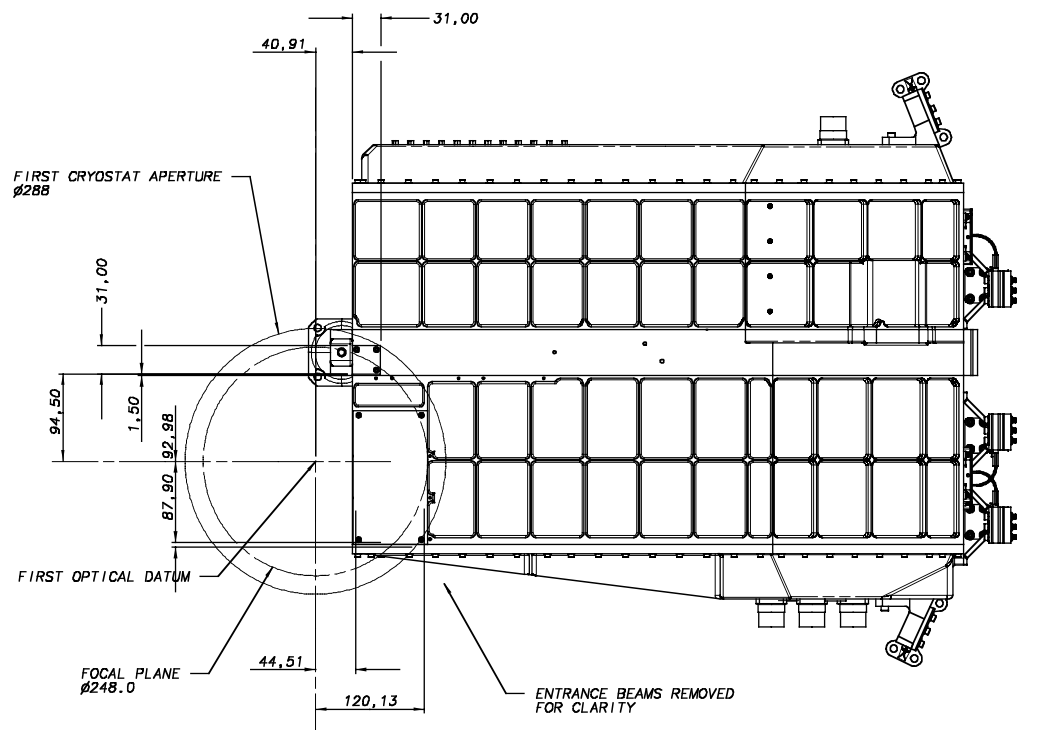

ANGULAR ACCURACY OF OPTICAL CUBE POSITION
 0.05° (3 ARC MIN).
 ANGULAR ACCURACY TO Xu, Yu, Zu CO-ORDINATES
 0.05° +/- OPTICAL CUBE ANGULAR TOL. (TBD.)
 REFER TO OPTICAL CUBE DRAWING No. A3/5264/305-16

ENTRANCE BEAMS

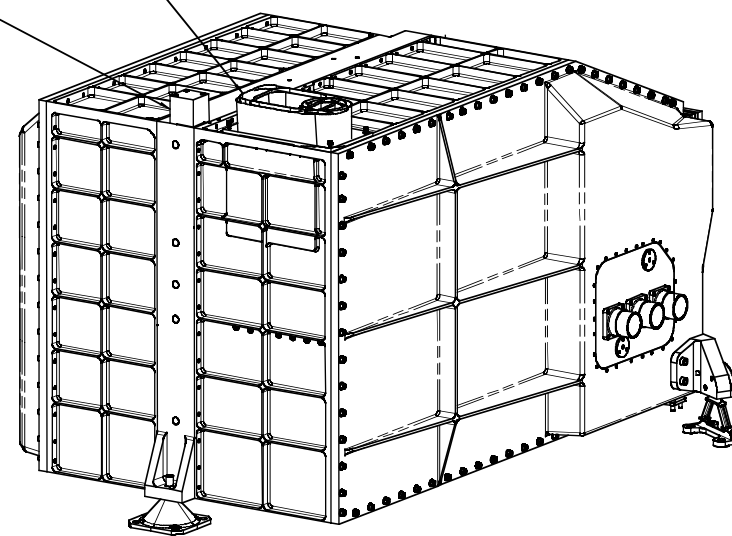

ONLY PRIMARY DIMENSIONS FOR THE OPTICAL BEAMS
 WHICH SHALL REMAIN FREE FROM OBSTRUCTION ARE SHOWN.
 REFER TO I1D-B FOR MORE DETAILED INFORMATION.

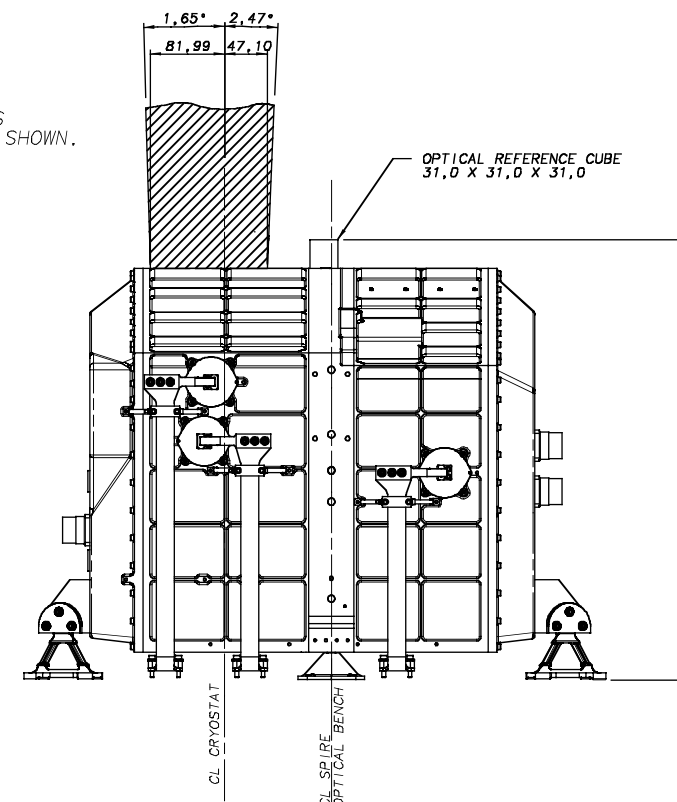

NOTE:-

- 1. ALL DIMENSIONS AT ROOM TEMPERATURE UNLESS OTHERWISE SPECIFIED

18	4/07/03	SEE CHANGE SHEET	
17	16/10/02	SEE CHANGE SHEET	
16	28/08/02	MODIFICATIONS AND CHANGE SHEET CREATED. DRAWING UPDATED TO ISSUE 16 THERE-ON.	
15	27/04/01	THERMAL STRAP INTERFACE MODIFIED. LEVEL 1 STRAP FIXING HOLES MOVED.	
14	23/11/01	CENTRE OF GRAVITY ADDED TO SHT 1. J-FET DESIGN UPDATED. STAY OUT HOLES REMOVED	
13	19/11/01	UPDATED RFI FILTER & PHOT CONNECTORS ADDED. FOCAL PLANE & *A* FRAME MOUNT DIM ADDED. SHEET 7 ADDED.	
DRAWN	ISSUE	DATE	AMENDMENT
AJC	1	24/11/01	

NOTE:-
 SEE CHANGE SHEET FOR DETAILS OF CHANGES MADE FROM ISSUE 16 ONWARDS

SPiRE Flight
 Assemblies
 COMPUTER FILE

PROTECTIVE FINISH
 ALOCROM 1200
 (ST. STEEL PARTS
 NATURAL)

MATERIAL & SPEC.
 AS LISTED

TOLERANCES UNLESS
 OTHERWISE STATED -
 LINEAR +/- 1.0
 ANGULAR +/- 0°15'

ESTD WT. 45.63kg (NO CONT)
 *SEE NOTE SHT. 1
 ACTL WT.

DIMENSIONS IN mm

SCALE 1:1

DEPARTMENT OF SPACE AND CLIMATE PHYSICS
 UNIVERSITY COLLEGE LONDON
 MULLARD SPACE SCIENCE LABORATORY, HOLMBURY ST. MARY,
 DORKING, SURREY.

TITLE
 SPIRE INTERFACE
 (OPTICAL DETAILS)

DRAWING No

A1 5264 300sht3

SHEET 3 OF 7

USED ON
HERSCHEL

DRAWING No.
A1 5264 300sht 4

THIRD ANGLE PROJECTION

DO NOT SCALE

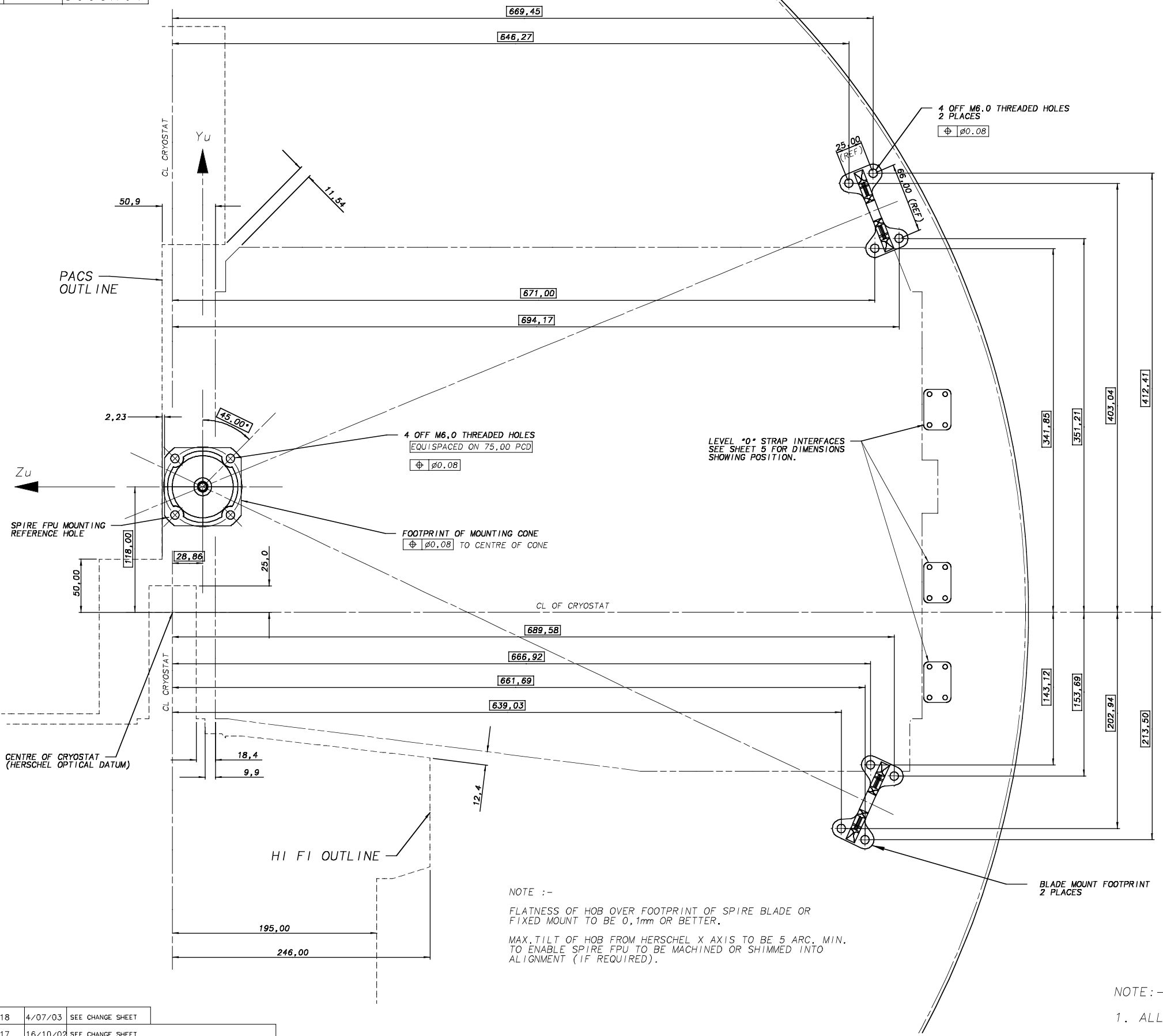

NOTE :-
FLATNESS OF HOB OVER FOOTPRINT OF SPIRE BLADE OR
FIXED MOUNT TO BE 0,1mm OR BETTER.
MAX. TILT OF HOB FROM HERSCHEL X AXIS TO BE 5 ARC. MIN.
TO ENABLE SPIRE FPU TO BE MACHINED OR SHIMMED INTO
ALIGNMENT (IF REQUIRED).

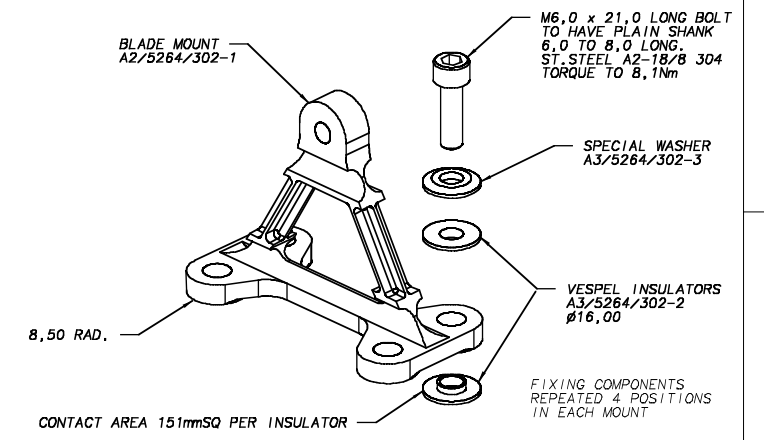

DETAIL OF BLADE MOUNT FIXINGS
SCALE 1 : 1

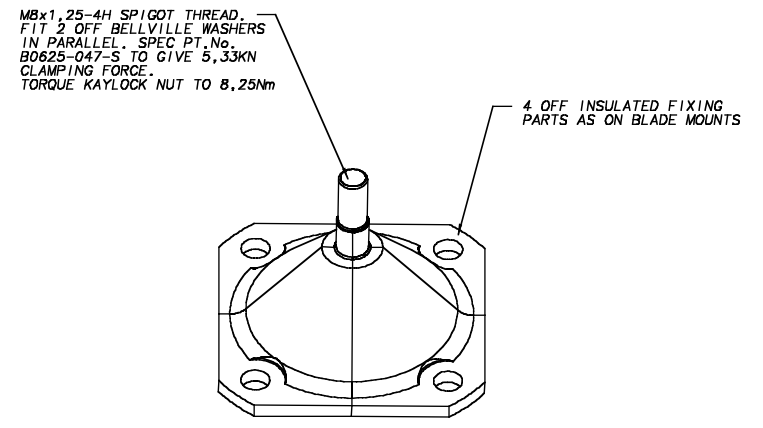

DETAIL OF FIXED MOUNTING
SCALE 1 : 1

NOTE :-
1. ALL DIMENSIONS AT ROOM TEMPERATURE

	18	4/07/03	SEE CHANGE SHEET
	17	16/10/02	SEE CHANGE SHEET
CHECKED	16	28/08/02	MODIFICATIONS AND CHANGE SHEET CREATED. DRAWING UPDATED TO ISSUE 16 THERE-ON.
	15	27/04/01	THERMAL STRAP INTERFACE MODIFIED. LEVEL 1 STRAP FIXING HOLES MOVED.
TRACED	14	23/11/01	CENTRE OF GRAVITY ADDED TO SHT 1. J-FET DESIGN UPDATED. STAY OUT HOLES REMOVED
PBG	13	19/11/01	UPDATED RFI FILTER & PHOT CONNECTORS ADDED. FOCAL PLANE & *A* FRAME MOUNT DIM ADDED. SHEET 7 ADDED.
DRAWN	ISSUE	DATE	AMENDMENT
AJC	1	24/11/01	

NOTE :-
SEE CHANGE SHEET FOR DETAILS OF CHANGES
MADE FROM ISSUE 16 ONWARDS

SPiRE Flight
Assemblies
COMPUTER FILE

PROTECTIVE FINISH ALOCROM 1200 (ST. STEEL PARTS NATURAL)	MATERIAL & SPEC. AS LISTED	TOLERANCES UNLESS OTHERWISE STATED - LINEAR +/- 1,0 ANGULAR +/- 0°15'
ESTD WT. 45,63kg (NO CONT) SEE NOTE SHT. 1		
ACTL WT.	DIMENSIONS IN mm	SCALE SCALE 1:2 & 1:1

DEPARTMENT OF SPACE AND CLIMATE PHYSICS UNIVERSITY COLLEGE LONDON MULLARD SPACE SCIENCE LABORATORY, HOLMBURY ST. MARY, DORKING, SURREY.	
TITLE SPIRE INTERFACE (INTERFACE FIXING DETAILS)	DRAWING No A1 5264 300sht 4
SHEET 4 OF 7	

USED ON
HERSCHEL

DRAWING No.
A1 5264 300sht5

THIRD ANGLE PROJECTION

DO NOT SCALE

2 x BELLEVILLE WASHERS
STACKED IN PARALLEL
PROVIDING 978N CLAMP
FORCE PER SCREW.
ST. STEEL SPEC PT.No.
B0375-020-S

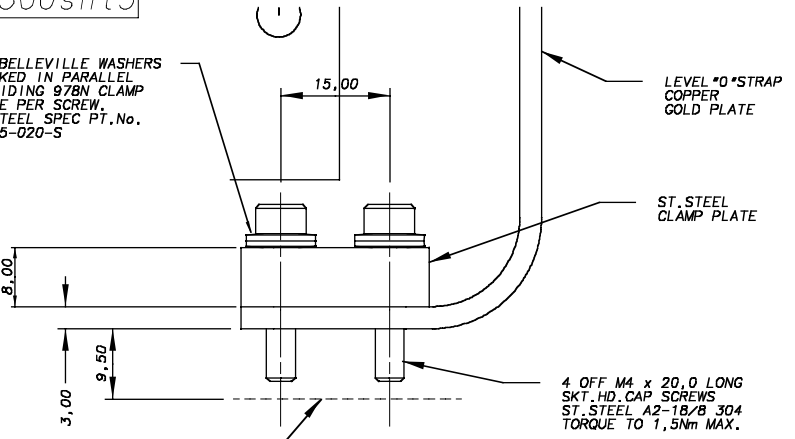

DETAIL "B" OF LEVEL "0" TO S/C INTERFACE
SCALE 2:1

4 OFF M4 x 20,0 LONG
SKT. HD. CAP SCREWS
ST. STEEL A2-18/B 304
TORQUE TO 1,5Nm MAX.

Ro 0,4 MICRON OR BETTER.
(BY VISUAL INSPECTION ONLY)
GOLD PLATED SURFACE

HSFPU EXTERNAL FINISHES:-

INSTRUMENT CASE AND EXTERNAL COVERS.
BLADE AND FIXED MOUNTING, EXTERNAL
FIXINGS.
COLD STRAPS.

ALOCROM 1200
NATURAL ST. STEEL
GOLD PLATED

NOTE:-

ANY THERMAL INTERFACE PROVISIONS NEEDED FOR THE JFET
UNITS ARE SHOWN ON INTERFACE DRAWINGS RELATING TO THOSE
UNITS.

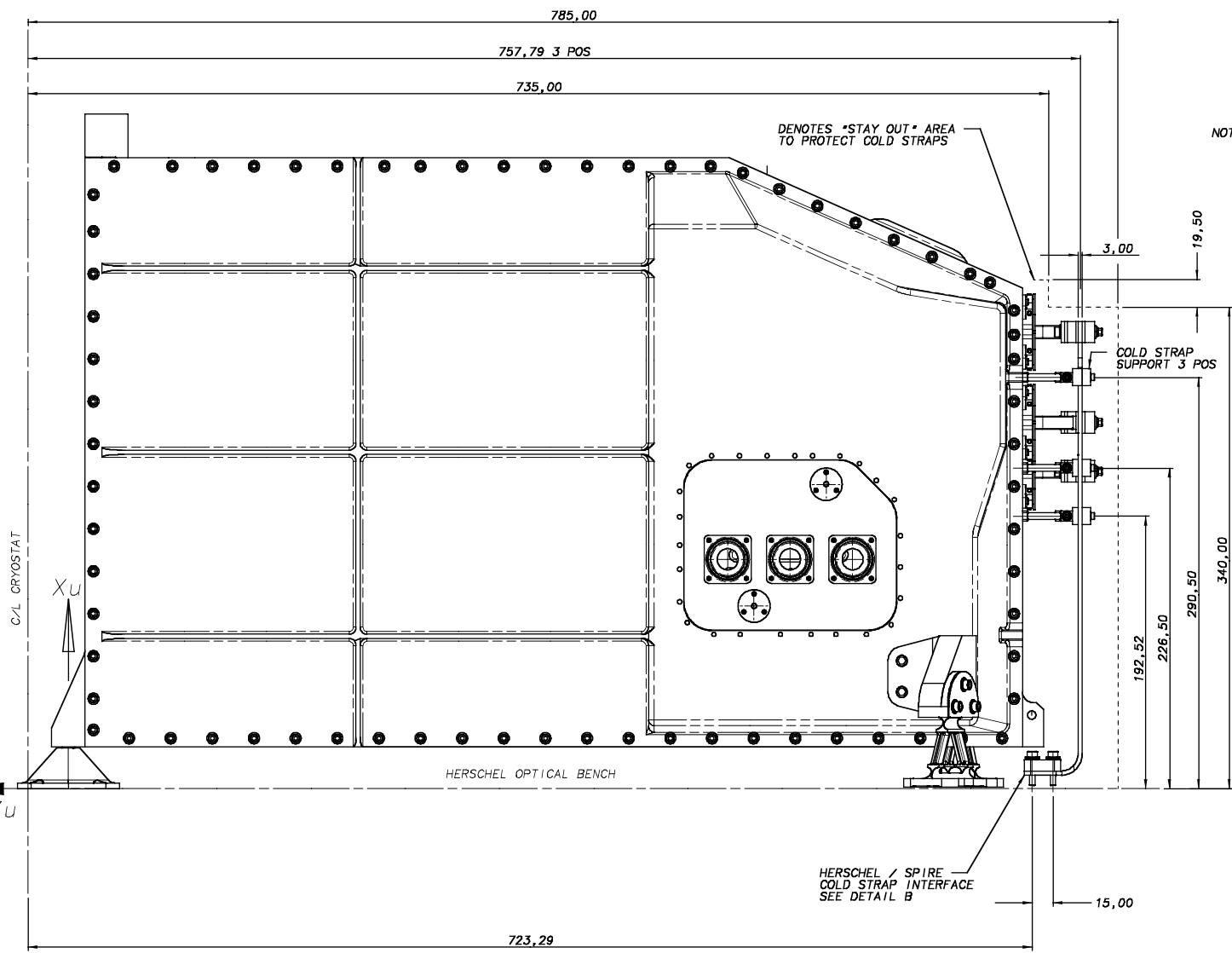

NOTE :- EVAPORATOR CONNECTION
ROTATED 180° SO HOLES
OFFSET TO LEFT OF
DIMENSIONED CENTRE

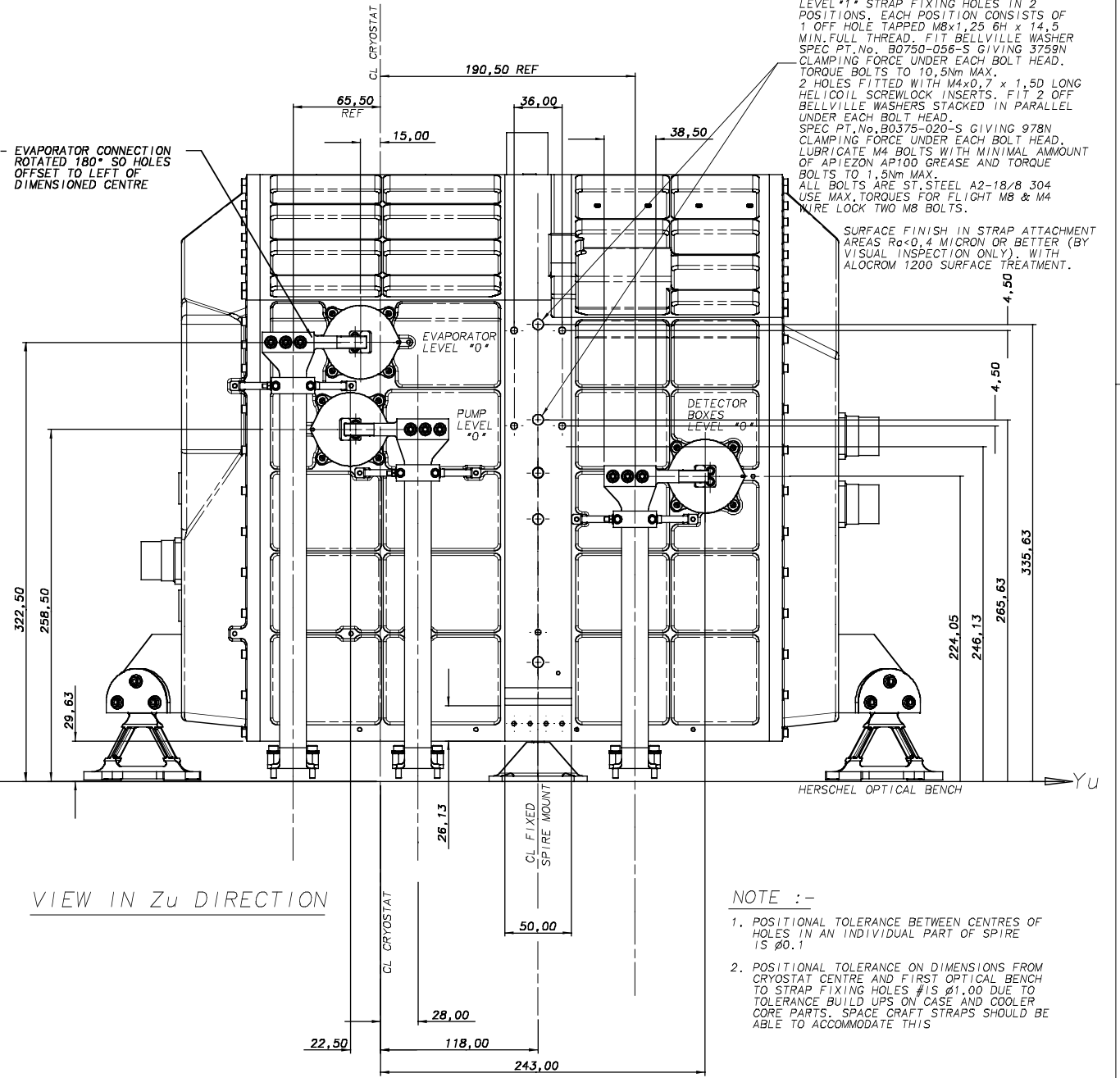

LEVEL *1* STRAP FIXING HOLES IN 2
POSITIONS. EACH POSITION CONSISTS OF
1 OFF HOLE TAPPED M8x1,25 6H x 14,5
MIN. FULL THREAD. FIT BELLVILLE WASHER
SPEC PT.No. B0750-056-S GIVING 3759N
CLAMPING FORCE UNDER EACH BOLT HEAD.
TORQUE BOLTS TO 10,5Nm MAX.
2 HOLES FITTED WITH M4x0,7 x 1,50 LONG
HELICOIL SCREWLOCK INSERTS. FIT 2 OFF
BELLVILLE WASHERS STACKED IN PARALLEL
UNDER EACH BOLT HEAD.
SPEC PT.No. B0375-020-S GIVING 978N
CLAMPING FORCE UNDER EACH BOLT HEAD.
LUBRICATE M4 BOLTS WITH MINIMAL AMOUNT
OF SPIEZON AP100 GREASE AND TORQUE
BOLTS TO 1,5Nm MAX.
ALL BOLTS ARE ST. STEEL A2-18/B 304
USE MAX. TORQUES FOR FLIGHT M8 & M4
WIRE LOCK TWO M8 BOLTS.

SURFACE FINISH IN STRAP ATTACHMENT
AREAS Ro<0,4 MICRON OR BETTER (BY
VISUAL INSPECTION ONLY). WITH
ALOCROM 1200 SURFACE TREATMENT.

VIEW IN Zu DIRECTION

NOTE :-

1. POSITIONAL TOLERANCE BETWEEN CENTRES OF HOLES IN AN INDIVIDUAL PART OF SPIRE IS 0.1
2. POSITIONAL TOLERANCE ON DIMENSIONS FROM CRYOSTAT CENTRE AND FIRST OPTICAL BENCH TO STRAP FIXING HOLES IS 0.1, 0.0 DUE TO TOLERANCE BUILD UPS ON CASE AND COOLER CORE PARTS. SPACE CRAFT STRAPS SHOULD BE ABLE TO ACCOMMODATE THIS

18	4/07/03	SEE CHANGE SHEET	
17	16/10/02	SEE CHANGE SHEET	
CHECKED	16	28/08/02	MODIFICATIONS AND CHANGE SHEET CREATED. DRAWING UPDATED TO ISSUE 16 THERE-ON.
	15	27/04/01	THERMAL STRAP INTERFACE MODIFIED. LEVEL 1 STRAP FIXING HOLES MOVED.
TRACED	14	23/11/01	CENTRE OF GRAVITY ADDED TO SHT 1. J-FET DESIGN UPDATED. STAY OUT HOLES REMOVED.
PBG	13	19/11/01	UPDATED RFI FILTER & PHOT CONNECTORS ADDED. FOCAL PLANE & *A* FRAME MOUNT DIM ADDED. SHEET 7 ADDED.
DRAWN	ISSUE	DATE	AMENDMENT
AJC	1	24/11/01	
			SPiRE Flight Assemblies
			COMPUTER FILE

NOTE :-
SEE CHANGE SHEET FOR DETAILS OF CHANGES
MADE FROM ISSUE 16 ONWARDS
NOTE :-
ALL DIMENSIONS AT ROOM TEMPERATURE

PROTECTIVE FINISH ALOCROM 1200 (ST. STEEL PARTS NATURAL)	MATERIAL & SPEC. AS LISTED	TOLERANCES UNLESS OTHERWISE STATED - LINEAR +/- 1.0 ANGULAR +/- 0°15'
ESTD WT. 45,63kg (NO CONT) SEE NOTE SHT.1	DIMENSIONS IN mm	SCALE 1:2 & 1:1
ACTL WT.		

DEPARTMENT OF SPACE AND CLIMATE PHYSICS UNIVERSITY COLLEGE LONDON MULLARD SPACE SCIENCE LABORATORY, HOLMBURY ST. MARY, DORKING, SURREY.		DRAWING No A1 5264 300sht5
TITLE SPIRE INTERFACE (THERMAL STRAP CONNECTIONS)		SHEET 5 OF 7

DRAWING No.

A1 5264 300 sht 6

THIRD ANGLE PROJECTION

DO NOT SCALE

USED ON
HERSCHEL

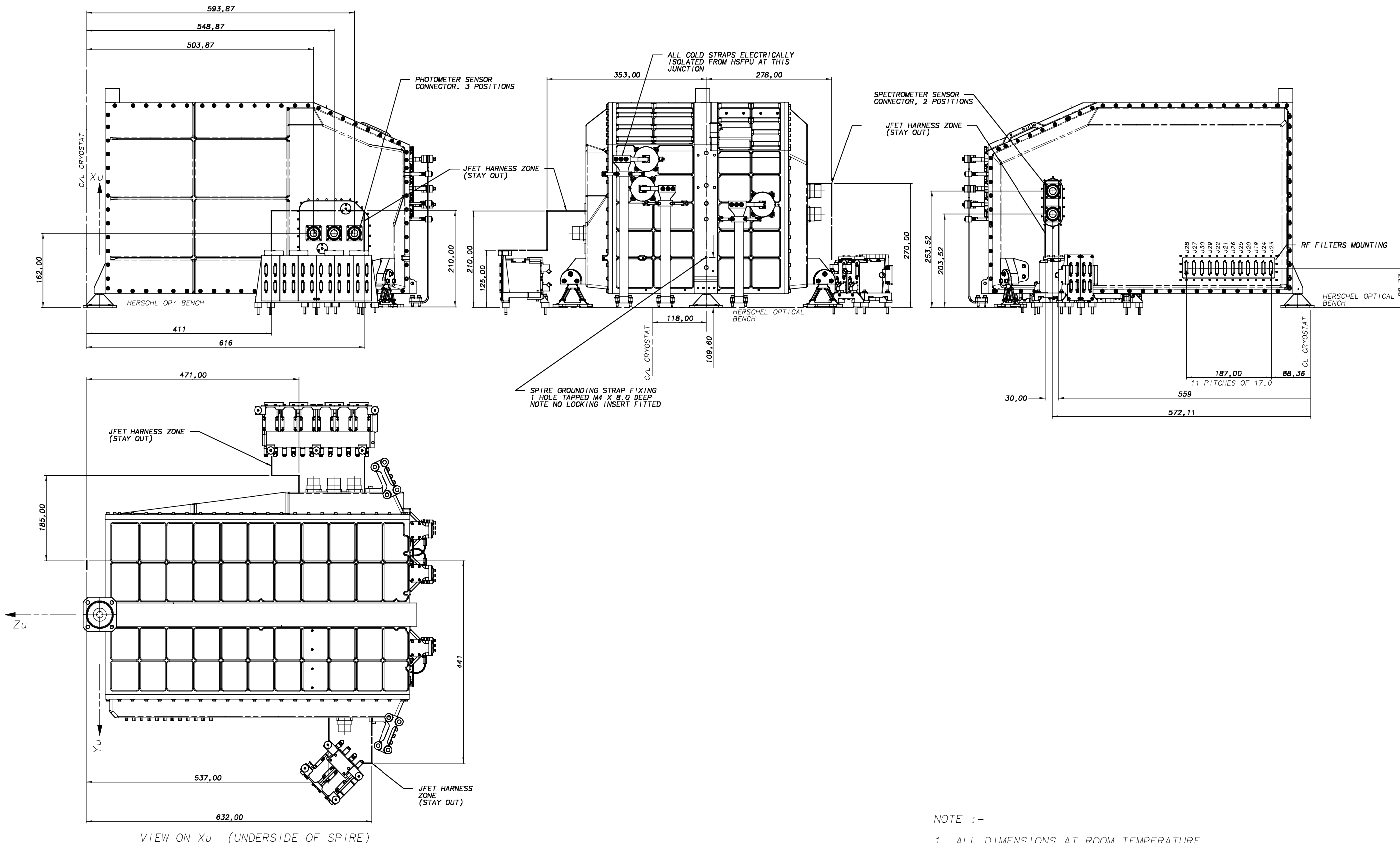

NOTE :-
1. ALL DIMENSIONS AT ROOM TEMPERATURE

	18	4/07/03	SEE CHANGE SHEET
	17	16/10/02	SEE CHANGE SHEET
CHECKED	16	28/08/02	MODIFICATIONS AND CHANGE SHEET CREATED. DRAWING UPDATED TO ISSUE 16 THERE-ON.
	15	27/04/01	THERMAL STRAP INTERFACE MODIFIED. LEVEL 1 STRAP FIXING HOLES MOVED.
TRACED	14	23/11/01	CENTRE OF GRAVITY ADDED TO SHT 1. J-FET DESIGN UPDATED. STAY OUT HOLES REMOVED
PBG	13	19/11/01	UPDATED RF1 FILTER & PHOT CONNECTORS ADDED. FOCAL PLANE & *A* FRAME MOUNT DIM ADDED. SHEET 7 ADDED.
DRAWN	ISSUE	DATE	AMENDMENT
AJC	1	24/11/01	

NOTE :-
SEE CHANGE SHEET FOR DETAILS OF CHANGES MADE FROM ISSUE 16 ONWARDS

SPIRE Flight Assemblies
COMPUTER FILE

PROTECTIVE FINISH ALOCROM 1200 (ST. STEEL PARTS NATURAL)	MATERIAL & SPEC. AS LISTED	TOLERANCES UNLESS OTHERWISE STATED - LINEAR +/- 1.0 ANGULAR +/- 0°15'
ESTD WT. 45.63kg (NO CONT) SEE NOTE SHT.1	DIMENSIONS IN mm	SCALE 1:4
ACTL WT.		

DEPARTMENT OF SPACE AND CLIMATE PHYSICS UNIVERSITY COLLEGE LONDON MULLARD SPACE SCIENCE LABORATORY, HOLMBURY ST. MARY, DORKING, SURREY.	
TITLE SPIRE INTERFACE (ELECTRICAL)	DRAWING No A1 5264 300 sht 6
SHEET 6 OF 7	

DRAWING No.

A1 5264 300sht7

THIRD ANGLE PROJECTION

DO NOT SCALE

USED ON
HERSCHEL

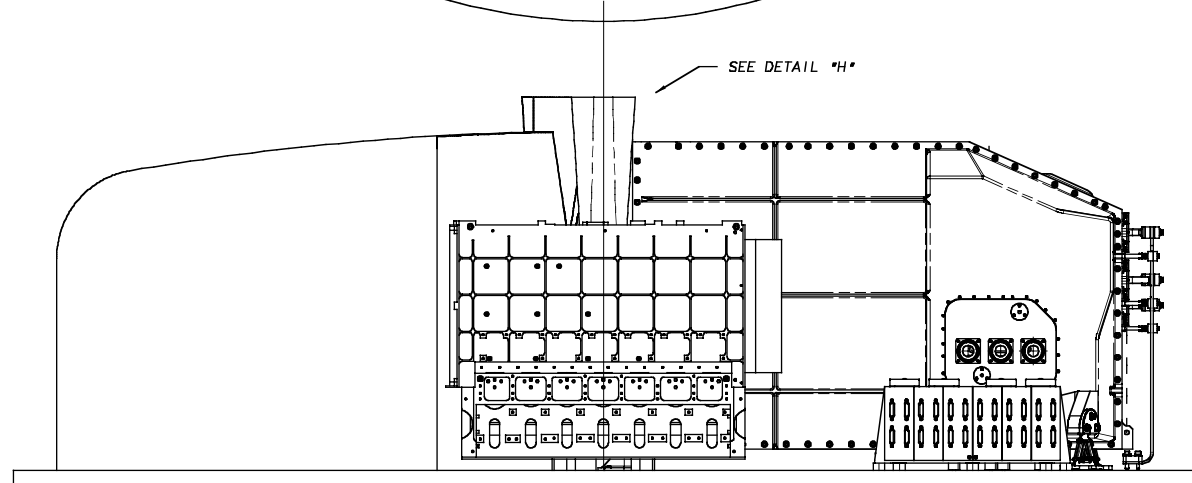
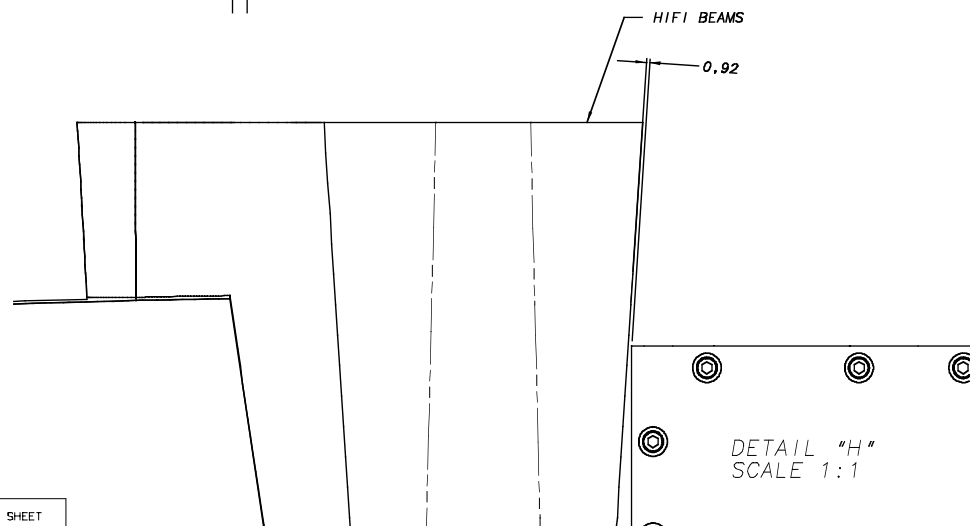
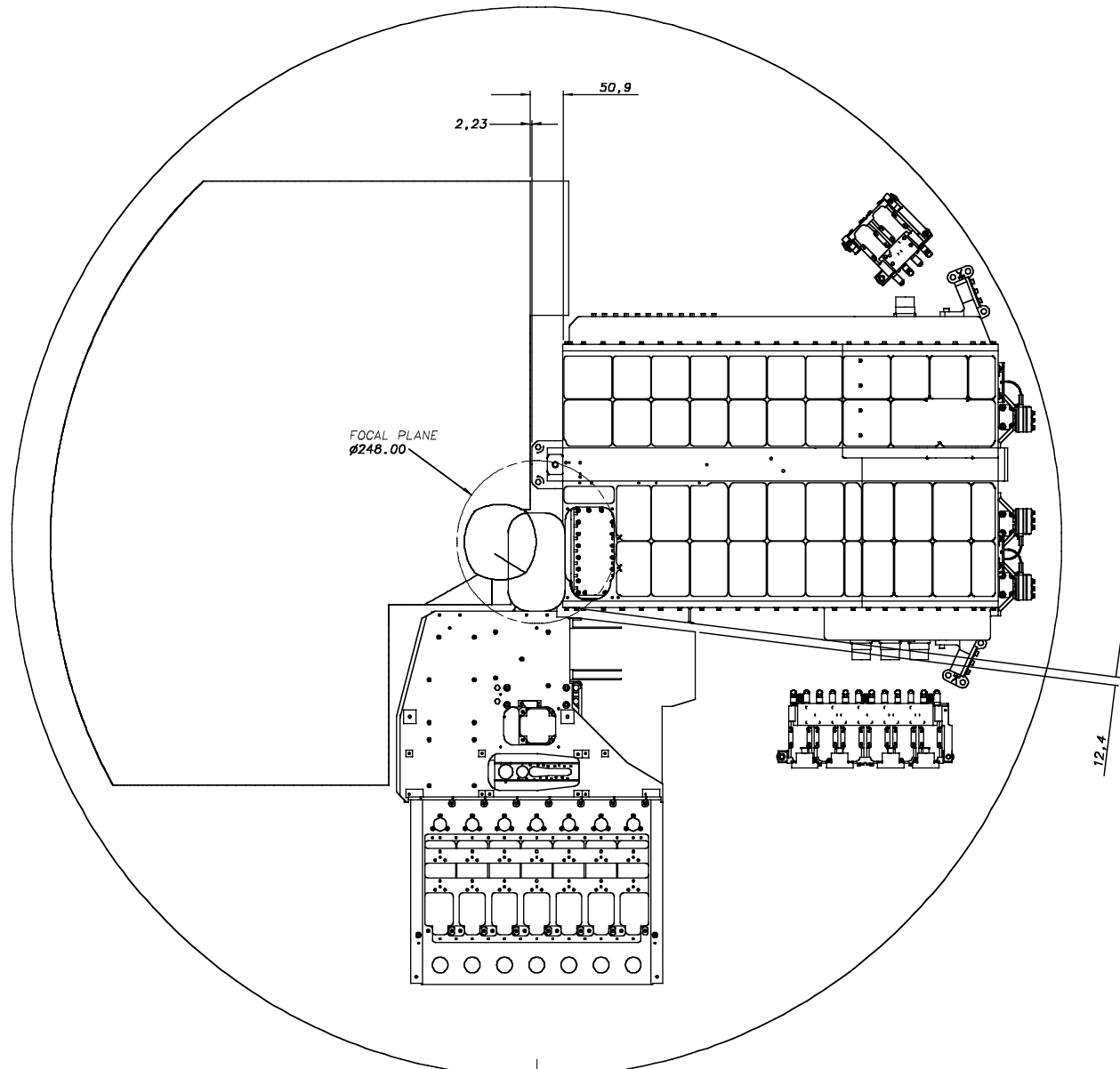
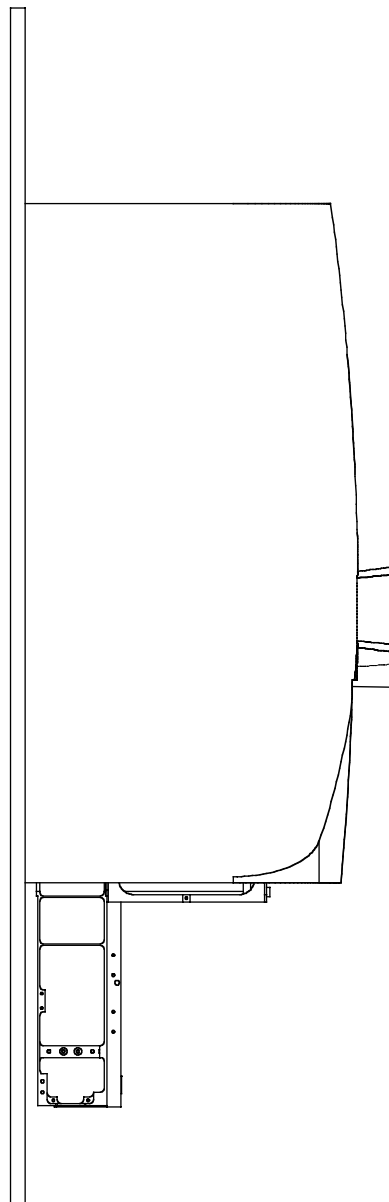

CHECKED	18	4/07/03	SEE CHANGE SHEET
	17	16/10/02	SEE CHANGE SHEET
	16	28/08/02	MODIFICATIONS AND CHANGE SHEET CREATED. DRAWING UPDATED TO ISSUE 16 THERE-ON.
	15	27/04/01	THERMAL STRAP INTERFACE MODIFIED. LEVEL 1 STRAP FIXING HOLES MOVED.
TRACED PBG	14	23/11/01	CENTRE OF GRAVITY ADDED TO SHT. 1. J-FET DESIGN UPDATED. STAY OUT HOLES REMOVED
	13	19/11/01	UPDATED RFI FILTER & PHOT CONNECTORS ADDED. FOCAL PLANE & *A* FRAME MOUNT DIM ADDED. SHEET 7 ADDED.
DRAWN AJC	ISSUE	DATE	AMENDMENT
	1	24/11/01	

NOTE:-
SEE CHANGE SHEET FOR DETAILS OF CHANGES
MADE FROM ISSUE 16 ONWARDS

SPIRE Flight
Assemblies
COMPUTER FILE

PROTECTIVE FINISH ALOCROM 1200 (ST. STEEL PARTS NATURAL)	MATERIAL & SPEC. AS LISTED	TOLERANCES UNLESS OTHERWISE STATED - LINEAR +/- 1.0 ANGULAR +/- 0°15'
ESTD WT. 45.63kg (NO CONT) *SEE NOTE SHT. 1	DIMENSIONS IN mm	SCALE
ACTL WT.		

DEPARTMENT OF SPACE AND CLIMATE PHYSICS UNIVERSITY COLLEGE LONDON MULLARD SPACE SCIENCE LABORATORY, HOLMBURY ST. MARY, DORKING, SURREY.	
TITLE SPIRE INTERFACE PACS AND HIFI OPTICAL & CLEARANCES	DRAWING No A1 5264 300sht7
SHEET 7 OF 7	

SSTD Rutherford Appleton Laboratory	Space Product Assurance Form <i>Mechanical Design Office</i>	Doc.No. :ISO9:FORM/MECH/006
		Issue : 2 Date : 21/12/2001 Page : 1 of 6
MODIFICATION SHEET		
THE CENTRAL LABORATORY OF THE RESEARCH COUNCILS RUTHERFORD APPLETON LABORATORY		
KE-2952	DRAWING NUMBER: KE-0104-360	
	DRAWING TITLE: 2 JFET RACK INTERFACE DRAWING	

Date:	12-Jun-2002
NCR/ECR:	
Modification Description:	<p>Connector identification markings updated. J15, J12, J17, J14 reversed with J11, J16, J13, J18.</p> <p>Connector Table updated accordingly</p> <p>RAISED ISSUE TO B 21-Jun-2002 K.Burke</p> <p>Connector Table, 2nd Label J2 corrected to read J3</p> <p>Note showing position of REF HOLE added</p> <p>RAISED ISSUE TO C 21-Jun-2002 K.Burke</p> <p>Parts table modified to read "JPL Supply" as a Remark in the JFET Module entry.</p> <p>Parts table modified to read "Backshell" rather than "Backplate" in the 15-way connector entry</p> <p>Parts table modified to read "Phosphor" rather than "Phosphur"</p> <p>Note 4 modified to read "J9-10 & J15-18" rather than "J9-14"</p> <p>RAISED ISSUE TO D 24-Jun-2002 M. Whalley</p> <p>CofG added, MOI table added, Note modified for warm testing torque, bolt material added, pin1 indicated for connectors.</p> <p>Raised to issue E 4/7/02 T.Froud</p>
Issue raised to:	E By:

SUPERSEDED ISSUES OF ALL DRAWING HARD COPIES TO BE DESTROYED

KE-2952

SSTD Rutherford Appleton Laboratory	Space Product Assurance Form <i>Mechanical Design Office</i>	Doc.No. :ISO9:FORM/MECH/006
		Issue : 2 Date : 21/12/2001 Page : 2 of 6
MODIFICATION SHEET		
THE CENTRAL LABORATORY OF THE RESEARCH COUNCILS RUTHERFORD APPLETON LABORATORY		
KE-2952	DRAWING NUMBER: KE-0104-360	
	DRAWING TITLE: 2 JFET RACK INTERFACE DRAWING	

Date:	07-Feb-2003
NCR/ECR:	
Modification Description:	<p>1. Swop connector pairs (MSW)</p> <p>2. move connector labels (MSW)</p> <p>3. make back harness into parts (MSW)</p> <p>4. Dimension and label thread lengths</p> <p>5. add column to parts list showing drawing numbers (also create repeat region BOM table)</p> <p>6. replace thermal strap part as an assembly</p> <p>7. change note 2 - "...dimension and to compensate for actual jfet module sizes..." and append note 2 with "pads on item 3 will also need machining if trial assembly of rack on flat surface shows gaps before fasteners are tightened"</p> <p>8. add note 5 " Heat capacity = {0.9 x mass} joules / Kelvin</p> <p>9. show insulation additions to feet (kapton tape washers)</p> <p>10. add note to section view showing that fasteners are coated with parylene C</p> <p>11. put m2.5 washers under various screws</p> <p>12. change note 3 to say "items 8 to be torqued to 2.1Nm above locking insert running torque</p> <p>13. add note 6 " fitted back harness to afford open access to 51 ways as shown"</p> <p>14. add note 7 " kapton tape insulators shall be cut to fit annuls of thermal standoff to within +/- 1"</p>
Issue raised to:	F By: IPG

SUPERSEDED ISSUES OF ALL DRAWING HARD COPIES TO BE DESTROYED

KE-2952

SSTD Rutherford Appleton Laboratory	Space Product Assurance Form <i>Mechanical Design Office</i>	Doc.No. :ISO9:FORM/MECH/006
		Issue : 2 Date : 21/12/2001 Page : 3 of 6
MODIFICATION SHEET		
THE CENTRAL LABORATORY OF THE RESEARCH COUNCILS RUTHERFORD APPLETON LABORATORY		
KE-2952	DRAWING NUMBER: KE-0104-360	
	DRAWING TITLE: 2 JFET RACK INTERFACE DRAWING	

Date:	12-Mar-2003
NCR/ECR:	
Modification Description:	<p>1. Thermal standoff positional dimensions changed to basic dimensions.</p> <p>2. Thermal strap interface dimensions added</p> <p>3. Note 3 modified to clarify that stud is set to depth then nut is torqued to 2.1Nm.</p> <p>4. Height of JFET rack dimension added.</p> <p>5. Note 8 added regarding the protrusion and trimming of the parylene coating</p> <p>6. Annotation moved (next to balloon) stating that the KE-0104-357 and 358 should not be confused (as they have different lengths of parylene coating).</p> <p>7. Typos fixed</p> <p>8. Unit mounting hole size and positional accuracy added</p>
Issue raised to:	G By: Iain Gilmour

SUPERSEDED ISSUES OF ALL DRAWING HARD COPIES TO BE DESTROYED

KE-2952

SSTD Rutherford Appleton Laboratory	Space Product Assurance Form <i>Mechanical Design Office</i>	Doc.No. :ISO9:FORM/MECH/006
		Issue : 2 Date : 21/12/2001 Page : 4 of 6
MODIFICATION SHEET		
THE CENTRAL LABORATORY OF THE RESEARCH COUNCILS RUTHERFORD APPLETON LABORATORY		
KE-2952	DRAWING NUMBER: KE-0104-360	
	DRAWING TITLE: 2 JFET RACK INTERFACE DRAWING	

Date:	20-May-2003
NCR/ECR:	
Modification Description:	<p>Added note to size of tapped holes for attachment of cooling strap (L-1/2)</p> <p>2 HOLES M4x0.7 1.5D LG HELICOIL FASTENER TO ENGAGE 1.5d TORQUE NOT TO EXCEED 2.5Nm</p>
Issue raised to:	H By: Kevin Burke

SUPERSEDED ISSUES OF ALL DRAWING HARD COPIES TO BE DESTROYED

KE-2952

SSTD Rutherford Appleton Laboratory	Space Product Assurance Form <i>Mechanical Design Office</i>	Doc.No. :ISO9:FORM/MECH/006
		Issue : 2 Date : 21/12/2001 Page : 5 of 6
MODIFICATION SHEET		
THE CENTRAL LABORATORY OF THE RESEARCH COUNCILS RUTHERFORD APPLETON LABORATORY		
KE-2952	DRAWING NUMBER: KE-0104-360	
	DRAWING TITLE: 2 JFET RACK INTERFACE DRAWING	

Date:	13-Oct-2003
NCR/ECR:	
Modification Description:	<p>1. Reflects new thermal standoff design with additional bush and upper and lower feet washers. Subsequent dimensions in X direction updated to new interface plane. New parts added to Parts List.</p> <p>2. Reflects new harness layout which simulates actual physical layout. Micro-D 15 way connector added to harness representation. Micro-D 37 way elliptical entry backshells replace standard circular entry versions. Mass of harness increased from 110g to 205g.</p> <p>3. L3 strap and interface assembly added. Views updated to show interface details and L3 strap hole definition.</p> <p>4. Mass of JFET modules reduced from 305g to 260g.</p> <p>5. Kapton tape removed from fastener and stand-off interfaces (note 7 deleted).</p> <p>6. Moments of inertia updated along with C of G position.</p> <p>7. Kapton tape note removed from L3 interface area.</p> <p>8. Incorrectly specified M2.5 x 8 long fasteners used to fasten JFET modules to front plate replaced with M3 x 8 long.</p> <p>9. Temperature sensor interface shown on both sides of the L3 interface sub-assembly.</p> <p>10. Distance between S/C connector I/F and rear of JFET harness increased due to addition of 15-way connectors to JFET harness.</p> <p>11. New dimensions applied to L3 interface area.</p> <p>12. Connector fasteners and nuts added to spacecraft connectors.</p>
Issue raised to:	I By: Dave Smart

SUPERSEDED ISSUES OF ALL DRAWING HARD COPIES TO BE DESTROYED

KE-2952

SSTD Rutherford Appleton Laboratory	Space Product Assurance Form <i>Mechanical Design Office</i>	Doc.No. :ISO9:FORM/MECH/006
		Issue : 2 Date : 21/12/2001 Page : 6 of 6
MODIFICATION SHEET		
THE CENTRAL LABORATORY OF THE RESEARCH COUNCILS RUTHERFORD APPLETON LABORATORY		
KE-2952	DRAWING NUMBER: KE-0104-360	
	DRAWING TITLE: 2 JFET RACK INTERFACE DRAWING	

Date:	12-Nov-2003
NCR/ECR:	
Modification Description:	<p>1. Harness re-routed to show clearance required to access connectors on the rear of the JFETS. Reference to note 6 added.</p> <p>2. Harness tie down points added.</p> <p>3. Note 8 added concerning the pre-fitting of the M4 fasteners prior to the assembly of the harness.</p>
Issue raised to:	J By: Dave Smart

? *John Decker Field* 2003.11.12 15:13:21 Z

SUPERSEDED ISSUES OF ALL DRAWING HARD COPIES TO BE DESTROYED

KE-2952

NOTE THESE Y&Z SUB-SYSTEM AXES ARE NOT PARALLEL TO SPACECRAFT AXES

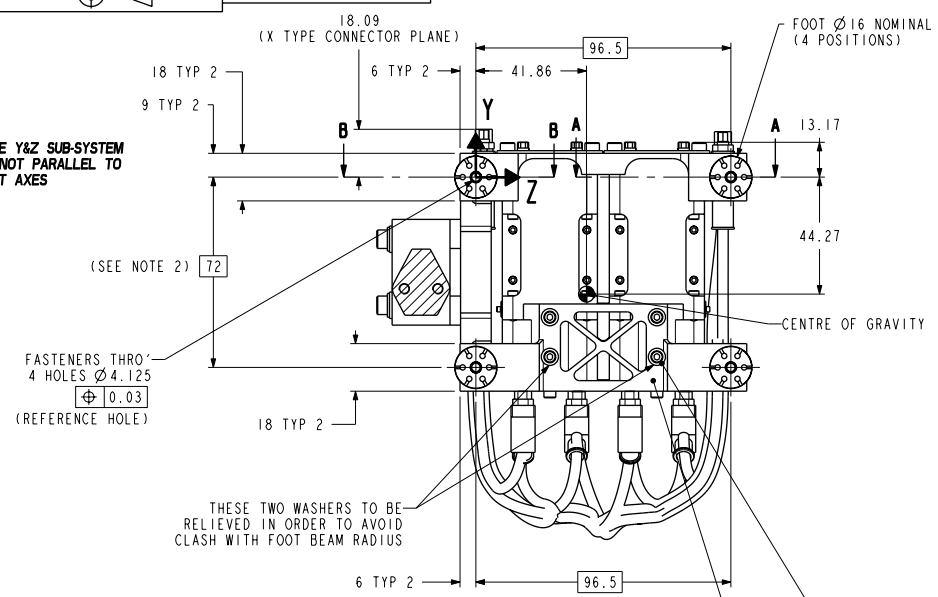

LABEL	TYPE	FUNCTION
J1	ALL MDM2SP	ALL SIGNAL FEEDS TO CRYOHARNESS
J2		
J3		
J4		
J5		
J6		
J7		
J8		
J9	MDM3TS	BIAS WIRES FROM CRYOHARNESS
J10	ALL MDM5TP	SIGNALS IN FROM DETECTORS
J11		
J12		
J13		
J14		
J15		
J16		
J17		
J18	ALL MDM5TP	BIAS FEEDS INTO MODULES

I _{xx}	1.71e+03
I _{yy}	1.94e+03
I _{zz}	2.31e+03

ITEM	PART NO.	DESCRIPTION	QTY	MASS/ITEM	TOTAL MASS	COMMENTS
1	Z3836-10209722	JFET MODULE	2	260.00	520.00	JPL SUPPLY
2	ZJFET_HARNESS	BACKHARNESS (10209784.1)	1	216.95	216.95	JPL SUPPLY
3	HARNESS_CLIP		2			
4	KE-0104-354	STEPPED THERMAL STANDOFF	4	1.70	6.80	
5	KE-0104-355	TOP THERMAL STANDOFF	4	0.87	3.47	
6	KE-0104-358	M4 BOLT (PARYLENE C COATED 26.5mm)	2	4.70	9.39	
7	KE-0104-361	FRONT PLATE - 2 JFET	1	48.01	48.01	
8	KE-0104-362	REAR FOOT BEAM - 2 JFET	1	33.50	33.50	
9	KE-0104-363	REAR TOP BEAM - 2 JFET	1	8.53	8.53	
10	KE-0104-365	M4 STUD (PARYLENE C COATED)	2	5.08	10.16	
11	KE-0104-367	THERMAL STANDOFF WASHER	4	0.39	1.55	
12	KE-0104-368	THERMAL STRAP ASSY - 2 JFET	1	23.28	23.28	
13	KE-0104-386	M4 NUT (5mm LONG)	2	1.31	2.62	
14	KE-0104-393	L3 INTERFACE ASSY	1	64.18	64.18	
15	KE-0104-397	THERMAL STANDOFF BUSH	4	0.94	3.76	
16	KE-0104-398	FOOT UPPER WASHER	4	0.14	0.55	
17	KE-0104-399	FOOT LOWER WASHER	4	0.34	1.35	
18	L3_STRAP_A	L3 STRAP	1	N/A		HERSCHEL SUPPLY
19	M2-5_WASHER	WASHER	8	0.11	0.86	S/STEEL BS970/1501 304S 11/15/31
20	M2-5_X_8LG.CPHD.SKT.SS	FASTENER	12	0.58	6.93	S/STEEL BS3506-1:1998 A2-70
21	M3_X_8LG.CPHD.SKT.SS	FASTENER	8	0.74	5.95	S/STEEL BS3506-1:1998 A2-70
				ASSEMBLY MASS	967.84 GRAMS	

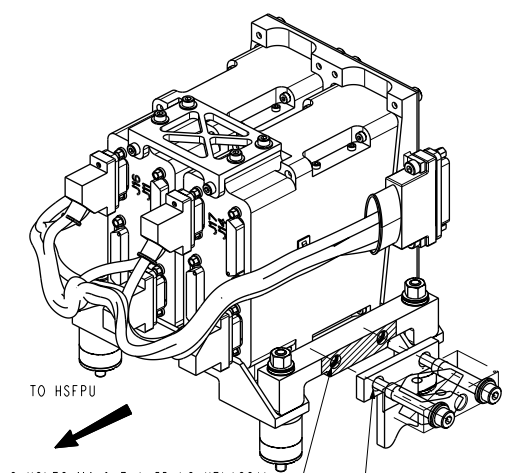
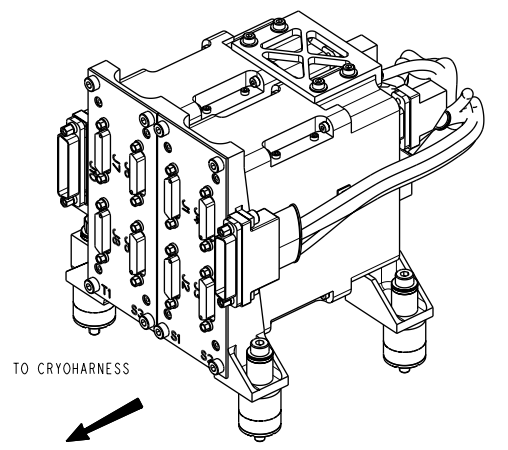
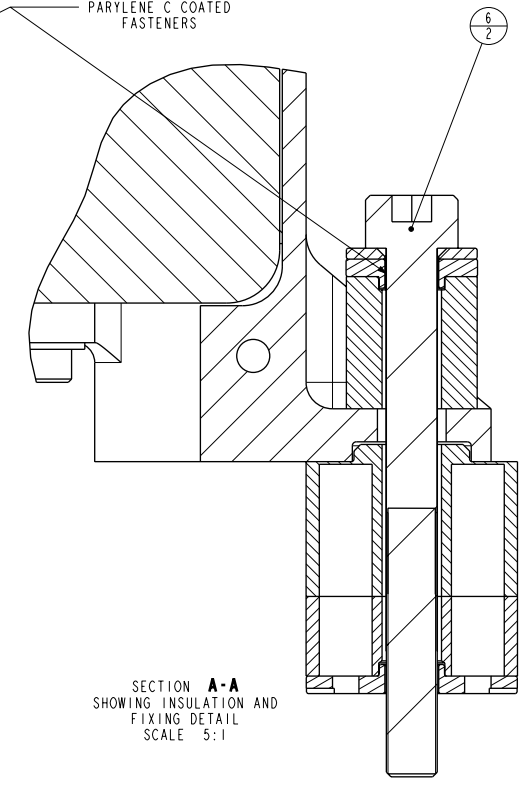
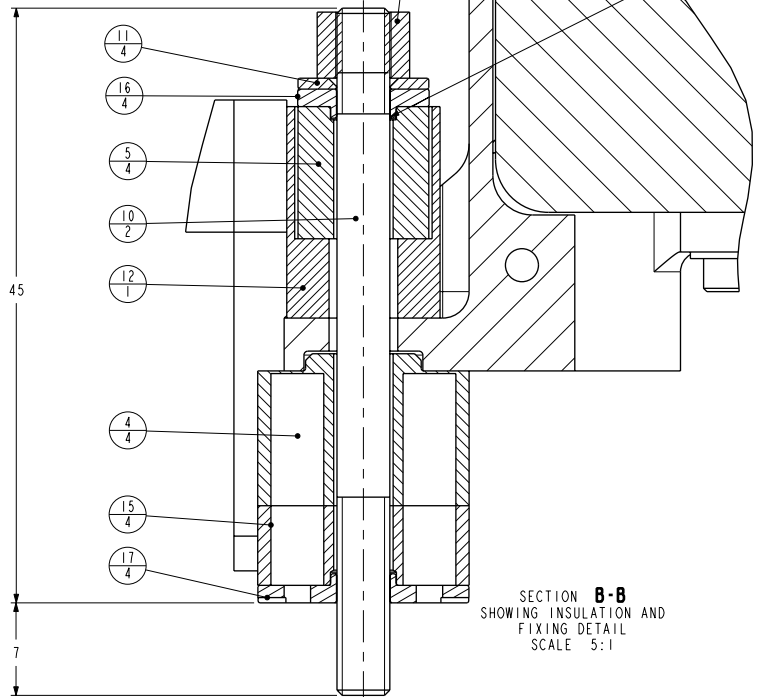
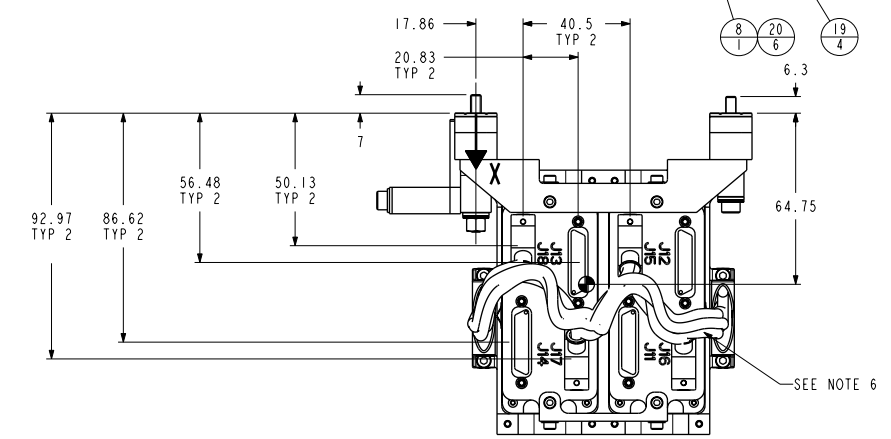

TEMPERATURE SENSOR INTERFACE SHOWN ON BOTH SIDES THERMAL CONTACT SURFACE DEFINED BY ENCLOSED AREA (SEE NOTE 7)

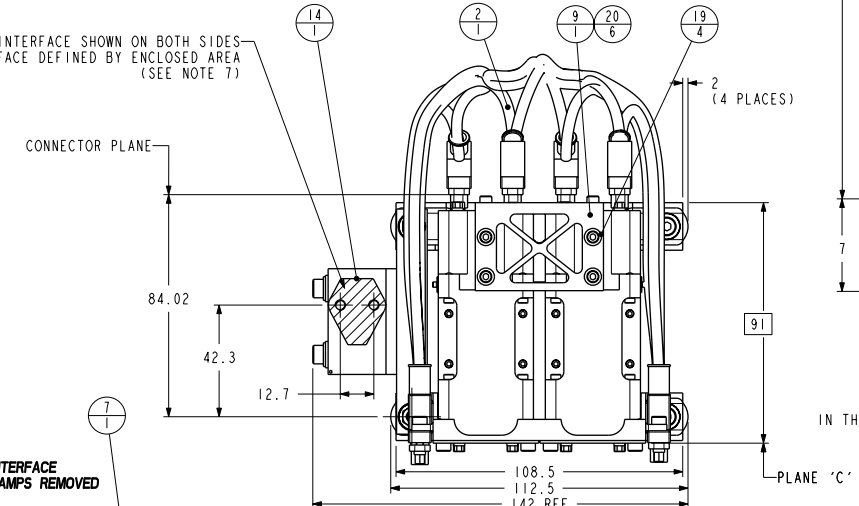

HARNESS TIE DOWN PARTS BONDED ON OUTER SIDE OF EACH JFET (HARNESS SHOWN IN WIREFRAME IN THIS VIEW TO SHOW TIE DOWN PART)

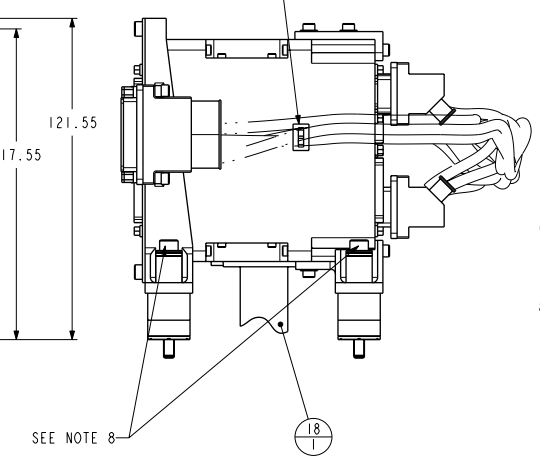

- NOTES:-
- BOND ITEM 15 TO 4 PRIOR TO ASSEMBLY. BOND ITEMS 16 & 14 TO 3 PRIOR TO ASSEMBLY. ITEMS 3 & 4 TO BE PERMANENTLY GLUED TO MATING SURFACES.
 - TO ATTAIN THE CORRECT MOUNTING INTERFACE DIMENSION, AND TO COMPENSATE FOR ACTUAL JFET MODULE SIZES, THE FOLLOWING PROCEDURE MUST BE FOLLOWED: PARTS 1 ARE TO BE MOUNTED TO PART 6. MEASURE FROM THE TOP OF PARTS 1 SHOWN AS PLANE 'C' TO THE TAIL END FACE OF PARTS 6, NOTING THE TWO VALUES. MACHINE RAISED PADS ON PART 7 TO REMOVE (VALUE - 87.7). PADS ON ITEM 8 WILL ALSO NEED MACHINING IF TRIAL ASSEMBLY OF RACK ON FLAT SURFACE SHOWS GAPS BEFORE FASTENERS ARE TIGHTENED.
 - ITEMS 6 TO BE TORQUED TO 2.1 Nm ABOVE LOCKING INSERT RUNNING TORQUE. ITEMS 13 TO BE TORQUED TO 2.1 Nm WITH STUD SET TO DEPTH SHOWN IN HOB LOCKING INSERT.
 - UNIT SHOWN FITTED WITH BACK-HARNESS MATING TO J9 - J10 & J15 - J18 BECAUSE THIS WILL BE FITTED BEFORE ITEM IS INTEGRATED TO HOB.
 - HEAT CAPACITY AT RT = 700 JOULES / KELVIN.
 - FITTED BACKHARNESS TO AFFORD OPEN ACCESS TO 51 WAYS AS SHOWN.
 - AFFIX ONE SENSOR WITH LONG BOLTS AND THEN THE OTHER ON THE REVERSE WITH NUTS
 - ITEMS 6 AND 11 TO BE PRE-FITTED BEFORE ITEM 2 IS FITTED

2 HOLES M4x0.7 1.5D LG HELICOIL FASTENER TO ENGAGE 1.5D TORQUE NOT TO EXCEED 2.5Nm

L3 STRAP 2 x Ø6 HOLES THRO 4mm STRAP TO SUIT BUSHES IN SUB-ASSEMBLY 13 (BLOCK SHOWN IN WIREFRAME TO PERMIT VIEW OF BUSHES)

ISSUE	DATE	MOD. No.	DRN. BY	CHKD.	APPD.	STATUS
J	12-Nov-03	KE-2952.	D. SMART			ISSUED
TOLERANCES UNLESS STATED			FINISH CLEAN REMOVE ALL BURRS		ORIGINAL SCALE 1:1 DO NOT SCALE	
MATERIAL & SPEC. SEE DETAILS			SURFACE TEXTURE µm SEE DETAILS UNLESS STATED		0 50mm	

PROJECT MEMBER	APPROVED
PROJECT MANAGER	
SYSTEM ENG	
ELECTRONICS ENG	
PA GROUP	
STRESS ENG	
OPTICAL ENG	
THERMAL ENG	
MECHANICAL ENG	

USED ON	© CLRC 2003
CENTRAL LABORATORY OF THE RESEARCH COUNCILS	
TITLE	2 JFET RACK INTERFACE DRAWING
SPIRE	
A 0-KE-0104-360-J	1 of 1

SSTD Rutherford Appleton Laboratory	Space Product Assurance Form <i>Mechanical Design Office</i>	Doc.No. :ISO9:FORM/MECH/006 Issue : 2 Date : 21/12/2001 Page : 2 of 5
KE-2953	MODIFICATION SHEET	
	THE CENTRAL LABORATORY OF THE RESEARCH COUNCILS RUTHERFORD APPLETON LABORATORY	
	DRAWING NUMBER: KE-0104-350	
DRAWING TITLE: 6 JFET RACK INTERFACE DRAWING		

Date:	7-Feb-2003
NCR/ECR:	
Modification Description:	<ol style="list-style-type: none"> Swop connector pairs (MSW) move connector labels (MSW) make back harness into parts (MSW) Dimension and label thread lengths add column to parts list showing drawing numbers (also create repeat region BOM table) replace thermal strap part as an assembly change note 2 – "...dimension and to compensate for actual jfet module sizes,..." and append note 2 with "pads on item 3 will also need machining if trial assembly of rack on flat surface shows gaps before fasteners are tightened" add note 5 "Heat capacity = {0.9 x mass} joules / Kelvin" show insulation additions to feet (kapton tape washers) add note to section view showing that fasteners are coated with parylene C put m2.5 washers under various screws change note 3 to say "items 8 to be torqued to 2.1Nm above locking insert running torque" add note 6 "fitted back harness to afford open access to to 51 ways as shown" add note 7 "kapton tape insulators shall be cut to fit annuls of thermal standoff to within +/- 1"
Issue raised to:	D
By:	Iain Gilmour

SUPERSEDED ISSUES OF ALL DRAWING HARD COPIES TO BE DESTROYED	
KE-2953	

SSTD Rutherford Appleton Laboratory	Space Product Assurance Form <i>Mechanical Design Office</i>	Doc.No. :ISO9:FORM/MECH/006 Issue : 2 Date : 21/12/2001 Page : 3 of 5
KE-2953	MODIFICATION SHEET	
	THE CENTRAL LABORATORY OF THE RESEARCH COUNCILS RUTHERFORD APPLETON LABORATORY	
	DRAWING NUMBER: KE-0104-350	
DRAWING TITLE: 6 JFET RACK INTERFACE DRAWING		

Date:	12-Mar-2003
NCR/ECR:	
Modification Description:	<ol style="list-style-type: none"> Thermal standoff positional dimensions changed to basic dimensions. Thermal strap interface dimensions added Note 8 added regarding the protrusion and trimming of the parylene coating Typos fixed 2 off thermal strap standard washers replaced with Belleville washers, BOM updated to this effect. Unit mounting hole size and positional accuracy added
Issue raised to:	E
By:	Iain Gilmour

SUPERSEDED ISSUES OF ALL DRAWING HARD COPIES TO BE DESTROYED	
KE-2953	

SSTD Rutherford Appleton Laboratory	Space Product Assurance Form <i>Mechanical Design Office</i>	Doc.No. :ISO9:FORM/MECH/006 Issue : 2 Date : 21/12/2001 Page : 4 of 5
KE-2953	MODIFICATION SHEET	
	THE CENTRAL LABORATORY OF THE RESEARCH COUNCILS RUTHERFORD APPLETON LABORATORY	
	DRAWING NUMBER: KE-0104-350	
DRAWING TITLE: 6 JFET RACK INTERFACE DRAWING		

Date:	20-May-2003
NCR/ECR:	
Modification Description:	<ol style="list-style-type: none"> Note Associated with tapped holes in the Thermal Strap Interface, first line modified for clarity to read: 2 HOLES M4x0.7 1.5D LG HELICOIL
Issue raised to:	F
By:	Kevin Burke

SUPERSEDED ISSUES OF ALL DRAWING HARD COPIES TO BE DESTROYED	
KE-2953	

SSTD Rutherford Appleton Laboratory	Space Product Assurance Form <i>Mechanical Design Office</i>	Doc.No. :ISO9:FORM/MECH/006 Issue : 2 Date : 21/12/2001 Page : 5 of 5
KE-2953	MODIFICATION SHEET	
	THE CENTRAL LABORATORY OF THE RESEARCH COUNCILS RUTHERFORD APPLETON LABORATORY	
	DRAWING NUMBER: KE-0104-350	
DRAWING TITLE: 6 JFET RACK INTERFACE DRAWING		

Date:	13-Oct-2003
NCR/ECR:	
Modification Description:	<ol style="list-style-type: none"> Reflects new thermal standoff design with additional bush and upper and lower feet washers. Subsequent dimensions in X direction updated to new interface plane. New parts added to Parts List. Reflects new harness layout which simulates actual physical layout. Micro-D 15 way connector added to harness representation. Micro-D 37 way elliptical entry backshells replace standard circular entry versions. Mass of harnesses increased from 165g to 270g. L3 strap and interface assembly added. Views updated and added to show interface details and L3 strap hole definition. Mass of JFET modules reduced from 305g to 260g. Kapton tape removed from fastener and stand-off interfaces (note 7 deleted). Moments of inertia updated along with C of G position. Fastener for thermal strap assembly changed to non parylene coated M4 x 45mm long. Kapton tape note removed from L3 interface area. Incorrectly specified M2.5 x 8 long fasteners used to fasten JFET modules to front plate replaced with M3 x 8 long. Temperature sensor interface shown on both sides of the L3 interface sub-assembly. Distance between S/C connector I/F and rear of JFET harness increased due to addition of 15-way connectors to JFET harness. Dimension between S/C connector plane and rear face of JFET module added. New dimensions applied to L3 interface area. Connector fasteners and nuts added to spacecraft connectors.
Issue raised to:	G
By:	Dave Smart

SUPERSEDED ISSUES OF ALL DRAWING HARD COPIES TO BE DESTROYED	
KE-2953	

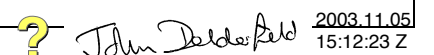
 2003.11.05
 15:12:23 Z

SPIRE IIDB issue 3.2 - ANNEX

Annex 2

SPIRE Reduced T.M.M.

Issue 2.3

SPIRE Reduced T.M.M.

The SPIRE reduced TMM diagram is given by the figure here under:

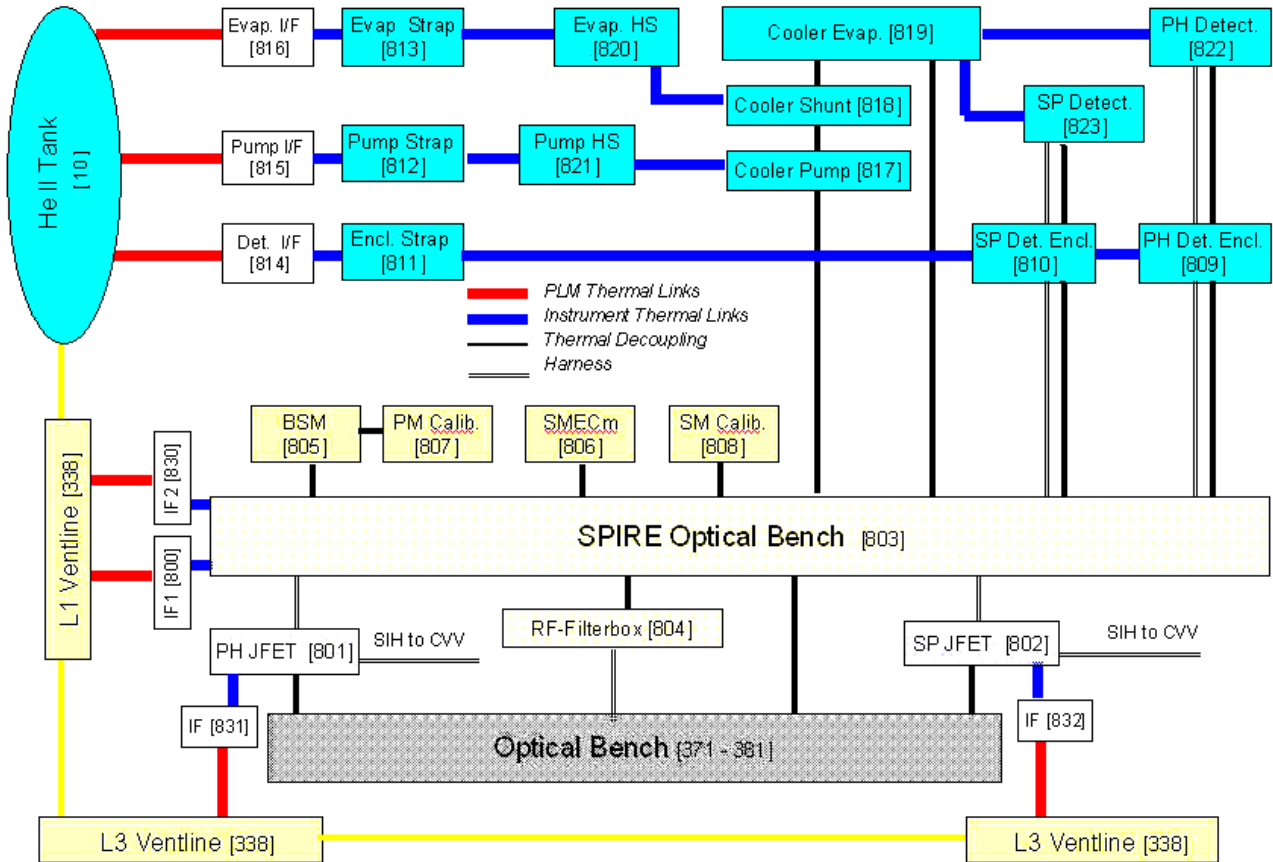

SPIRE reduced TMM diagram

```

#####
#
#           SPIRE Interface Thermal Model
#
#   Filename:      spirntrm23.d
#
#   Author:       AS Goizel
#   Email:        a.goizel@rl.ac.uk
#
#   Issue:        2.3
#   Created:      20.01.2003
#
#   Esatan Version: 8.7.1
#
#####
#
#   Before pre-processing the SPIRE ITMM, select the following options:
#
#   - Select the level of margin to be applied on the mechanisms internal
#     dissipation with the variable "margin_fac" in the $CONSTANTS Block
#     (1.2 is default value)
#
#####
#
#   Please Note:
#
#   For average case, the power on SCAL is applied to the FPU node (#803) to
#   remove instabilities linked to temperature dependant material properties .
#
#####
#
#   List of Changes:
#
#   06.12.02 - Issue 2   - Baseline SPIRE ITMM.
#   20.01.03 - Issue 2.1 - Change in SPIRE external and flexible L0 Strap
#                       Dimensions (Overall conductance of L0 straps changed
#                       from 200 mW/K to 150 mW/K.
#   03.03.03 - Issue 2.2 - SCAL (node 808) dissipation applied to FPU (node 803)
#                       for average mode.
#                       - Few GL links declared in VARS1 rather than in GL Block
#                       to allow for esatan Sun/PC platforms compatibility.
#                       - Changes in VARS to allow better setup of the evaporator,
#                       node (819) and heat-switches status according to the
#                       type of analysis (no need to select the analysis mode
#                       anymore).
#   27.03.03 - Issue 2.3 - SCAL dissipation down to 2 mW
#                       - busbar update
#                       - BDA update
#                       - vespel on L1 foot supports for elec iso
#                       - L1 additional IF node for double L1 strap
#                       - 2 additional nodes for L3 strap attachment
#                       - L3 JFETs isolation supports updated
#                       - L0 strap conductances updated
#
#   Changes by K. Wagner:
#   17.02.03           For transient calculations following capacities set
#                       to zero in eplmntdm.d (instability problem):
#                       805, 806, 807, 808, 811, 812, 813, 814, 815, 816, 818
#                       to be included in spirntrm instead?
#   19.02.03           $VARIABLES1/timeline analysis: selection of dissipation
#                       profiles done via control variable "SPSUBMD" (no longer
#                       via TIMEN), to have access from within HERSCHEL mainmodel
#   07.03.03           avg. dissipation call introduced within timeline
#
#####
#
#   This file has been formatted as a deliverable for Astrium
#####

$MODEL SPIRNTRM
#=====

```

\$NODES

#=====

#Level 2

D801 = 'PH_JFET_ENCLOSURE', T = 10.0D0, C = SHCAL(T801)*2.348D0;
 D802 = 'SP_JFET_ENCLOSURE', T = 10.0D0, C = SHCAL(T802)*0.81342D0;

#Level 1

D800 = 'L1 Strap IF1 @ SOB', T = 5.0D0, C = 0.0; # assumption
 D803 = 'FPU_OPTICAL_BENCH', T = 4.0D0, C = SHCAL(T803)*26.75D0;
 D804 = 'RF_FILTER_BOXES', T = 4.0D0, C = SHCAL(T804)*1.465D0;
 D805 = 'BSM', T = 4.0D0, C = SHCAL(T805)*1.1D0;
 D806 = 'SMECM', T = 4.0D0, C = SHCAL(T806)*1.043D0;
 D807 = 'PH_CALIB', T = 4.0D0, C = SHCAL(T807)*0.03D0;
 D808 = 'SPEC_CALIB', T = 4.0D0, C = SHCAL(T808)*0.0002041D0;

#Level 0

D809 = 'PH_DETECTOR_ENCLOSURE', T = 1.8D0, C =
 (SHCAL(T809)*3.568D0)+(SHCSS(T809)*0.114)+(SHCINV(T809)*0.192D0)+(SHCSI(T809)*0.048D0);
 D810 = 'SP_DETECTOR_ENCLOSURE', T = 1.8D0, C =
 (SHCAL(T810)*1.468D0)+(SHCSS(T810)*0.076)+(SHCINV(T810)*0.128D0)+(SHCSI(T810)*0.032D0);
 D811 = ' L0 Enclosure Flexible Strap', T = 1.8D0, C = SHCAL(T811)*6.16D-3;
 D812 = ' L0 Pump Flexible Strap', T = 1.8D0, C = SHCAL(T812)*6.16D-3;
 D813 = ' L0 Evap Flexible Strap', T = 1.8D0, C = SHCAL(T813)*6.16D-3;
 D814 = ' L0 Enclosure External Strap', T = 1.8D0, C = SHCAL(T814)*45.4D-3;
 D815 = ' L0 Pump External Strap', T = 1.8D0, C = SHCAL(T815)*52.3D-3;
 D816 = ' L0 Evaporator External Strap', T = 1.8D0, C = SHCAL(T816)*65.3D-3;
 D817 = 'COOLER_PUMP', T = 1.8D0, C = SHCTI(T817)*0.150D0;
 D818 = 'COOLER_SHUNT', T = 1.8D0, C = SHCTI(T818)*0.01D0;
 B819 = 'COOLER_EVAP', T = 0.29D0, C = SHCTI(T819)*0.084D0;
 D820 = 'COOLER_EVAP_HS', T = 1.8D0, C = SHCTI(T820)*0.074D0;
 D821 = 'COOLER_PUMP_HS', T = 1.8D0, C = SHCTI(T821)*0.074D0;

300 mK Level

D822 = 'PH_DETECTORS', T = 0.3D0, C = (SHCINV(T822)*0.435D0)
 + (SHCCU(T822)*0.709D0);
 D823 = 'SP_DETECTORS', T = 0.3D0, C = (SHCINV(T823)*0.281D0)
 + (SHCCU(T823)*0.254D0);

New L1 and L3 interface nodes

D830 = 'L1 Strap IF2 @ SOB', T = 5.0D0, C = 0.0D0; # assumption
 D831 = 'PH_L3 IF', T = 0.3D0, C = 0.0D0;
 D832 = 'SP_L3 IF', T = 0.3D0, C = 0.0D0;

\$CONDUCTORS

#=====

 #####
 # SPIRE Interface Definition with HERSCHEL
 #

```

#####
#####
#
# The following conductive links need to be integrated into HERSCHEL with the appropriate
# node numbers
#
#   HERSCHEL,SPIRE ----- MATERIAL ----- X-SECTION ----- LENGTH
#
#GL( HOB , 801 ) = 0.00504;
#GL( CVV , 801 ) = Harness to CVV;
#GL( L3 Ventline, 831 ) = L3 strap;
#
#GL( HOB , 802 ) = 0.00405;
#GL( CVV , 802 ) = Harness to CVV;
#GL( L3 Ventline, 832 ) = L3 strap;
#
#L1 Cone Support (effective xsect)
#GL( HOB , 803 ) = 1.0 / (1.0/(CNDFNC(3,SPIRE:K_SSTEEL) * 53.154D-06 / 0.0334D0)
+1.0D0/(4.0D0*151.0D-6*CNDFNC(3,SPIRE:K_VES)/0.001D0));
#L1 A-Frame Supports with correl factor
#GL( HOB , 803 ) = 1.0 / (1.0/(CNDFNC(3,SPIRE:K_SSTEEL)*0.65D0*2.0D0*34.0D-06
/0.027D0)+2.0D0/(4.0D0*151.0D-6*CNDFNC(3,SPIRE:K_VES)/0.001D0));
#
#GL( HOB , 804 ) = HERSCHEL RF Filter Harness;
#
#GL( HeII Flexible IF, 814 ) = HERSCHEL L0 Interface at HeII Tank;
#GL( HeII Flexible IF, 815 ) = HERSCHEL L0 Interface at HeII Tank;
#GL( HeII Flexible IF, 816 ) = HERSCHEL L0 Interface at HeII Tank;
#
#GL( L1Ventline IF1 , 800 ) = HERSCHEL L1 strap1;
#GL( L1Ventline IF2 , 830 ) = HERSCHEL L1 strap2;
#
# The following files includes the radiative couplings of SPIRE with HERSCHEL
#
#   $INCLUDE "spire_gr.d"
#
#####
#####

#####
#####
#
#                               SPIRE INTERNAL CONDUCTIVE COUPLINGS
#
#####
#####

# SPIRE Level 3 Strap Interface
#-----

GL( 801 , 831 ) = 0.138 ;
GL( 802 , 832 ) = 0.138 ;

# Level 2 to 1 Harness
#-----

# Photometer ----- 12 axs ----- STT -----
-----RF screen -----
GL( 801, 803 ) = CNDFNC(3,K_MANGANIN) * (5.47D-8 * 473.06D0 + 1.37D-8 * 78.84D0) ;
GL( 801, 803 ) = CNDFNC(3,K_TEF) * (4.38D-7 * 473.06D0 + 1.1D-7 * 78.84D0) ;
GL( 801, 803 ) = CNDFNC(3,K_SSTEEL) * (1.95D-7 * 473.06D0 + 1.95D-7 * 78.84D0 +
192.0D0 * 5.027D-9 * 78.84D0) ;
GL( 801, 803 ) = CNDFNC(3,K_TEF) * (7.54D-7 * 473.06D0 + 7.54D-7 * 78.84D0) ;

# Harness Supports - 7.5 supports / JFET enclosure - assumption
GL( 801, 803 ) = CNDFNC(3,K_VES) * 7.5D0 * 5.0E-06 / 0.080D0;

# Spectrometer ----- 12 axs ----- STT -----
-----RF screen -----

```

```

GL( 802, 803 ) = CNDFNC(3,K_MANGANIN) * (5.47D-8 * 98.48D0 + 1.37D-8 * 17.26D0) ;
GL( 802, 803 ) = CNDFNC(3,K_TEF) * (4.38D-7 * 98.48D0 + 1.1D-7 * 17.26D0) ;
GL( 802, 803 ) = CNDFNC(3,K_SSTEEL) * (1.95D-7 * 98.48D0 + 1.95D-7 * 17.26D0 +
192.0D0*5.027D-9 * 17.26D0) ;
GL( 802, 803 ) = CNDFNC(3,K_TEF) * (7.54D-7 * 98.48D0 + 7.54D-7 * 17.26D0) ;

```

Harness Supports - 7.5 supports / JFET enclosure - assumption

```

GL( 802, 803 ) = CNDFNC(3,K_VES) * 7.5D0 * 5.0E-06 / 0.080D0;

```

Level 1

#-----

```

GL( 803, 804 ) = 6.0D0*CNDFNC(3,M4COND_up);
#Mechanisms and Calib sources to Level 1 SOB
GL( 803, 805 ) = 4.0D0*CNDFNC(3,M4COND_up);
GL( 803, 806 ) = 4.0D0*CNDFNC(3,M4COND_up);
GL( 803, 808 ) = CNDFNC(3,K_TOR) * 5.30D-06 / 0.02D0 ; #single SCAL
source
GL( 805, 807 ) = 4.0D0*CNDFNC(3,M4COND_up);

```

Level 1 to Level 0

#-----

Photometer

```

GL( 803, 809 ) = CNDFNC(3,K_SSTEEL) * 45.96D-06 / 0.0346D0; #L1-
L0 ph enclosure Cone supports effective A
GL( 803, 809 ) = CNDFNC(3,K_SSTEEL) * 2.0D0*25.0D-06 / 0.0362D0; #L1-
L0 ph enclosure A-Frame supports
# ----- 12 axs ----- STT -----
GL( 803, 809 ) = CNDFNC(3,K_MANGANIN) * (5.47D-8 * 1208.39D0 + 1.37D-8 * 201.4D0)
;
GL( 803, 809 ) = CNDFNC(3,K_TEF) * (4.38D-7 * 1208.39D0 + 1.1D-7 * 201.4D0)
;
GL( 803, 809 ) = CNDFNC(3,K_SSTEEL) * (1.95D-7 * 1208.39D0 + 1.95D-7 * 201.4D0)
;
GL( 803, 809 ) = CNDFNC(3,K_TEF) * (7.54D-7 * 1208.39D0 + 7.54D-7 * 201.4D0)
;
# Harness Supports - assumption
GL( 803, 809 ) = CNDFNC(3,K_VES) * 9.0D0 * 5.0E-06 / 0.080D0;

```

Spectrometer

```

GL( 803, 810 ) = CNDFNC(3,K_SSTEEL) * 3.0D0*10.38D-06 / 0.0346D0; #L1-
L0 sp enclosure supports effective A/L
# ----- 12 axs ----- STT -----
GL( 803, 810 ) = CNDFNC(3,K_MANGANIN) * (5.47D-8 * 264.18D0 + 1.37D-8 * 46.63D0) ;
GL( 803, 810 ) = CNDFNC(3,K_TEF) * (4.38D-7 * 264.18D0 + 1.1D-7 * 46.63D0) ;
GL( 803, 810 ) = CNDFNC(3,K_SSTEEL) * (1.95D-7 * 264.18D0 + 1.95D-7 * 46.63D0) ;
GL( 803, 810 ) = CNDFNC(3,K_TEF) * (7.54D-7 * 264.18D0 + 7.54D-7 * 46.63D0) ;
# Harness Supports - assumption
GL( 803, 810 ) = CNDFNC(3,K_VES) * 6.0D0 * 5.0E-06 / 0.080D0;

```

300mK System

#-----

Photometer

```

GL( 809, 822 ) = CNDFNC(3,K_KEV29) * 0.00029 * 3.0; #Ph BDA
Supports
GL( 809, 822 ) = 12.0 * 0.286D-06; #L0 to
300mK ph harness
GL( 809, 822 ) = CNDFNC(3,K_KEV29) * 7.07D-06 / 0.025D0; #ph
enclosure busbar feedthru

```

Spectrometer

```

GL( 810, 823 ) = CNDFNC(3,K_KEV29) * 0.00029 * 2.0; #Sp BDA
Supports

```

```

GL( 810, 823 ) = 3.0 * 0.286D-06; #L0 to
300mK sp harness
GL( 810, 823 ) = CNDFNC(3,K_KEV29) * 2.36D-06 / 0.025D0; #sp
enclosure busbar feedthru

# 3He COOLER
#-----

# Shunt
GL( 817, 818 ) = CNDFNC(3,K_TI6AL4V) * 6.41D-06 / 0.038D0; #pump-
shunt tube
GL( 818, 819 ) = CNDFNC(3,K_TI6AL4V) * 6.41D-06 / 0.06D0; #shunt-
evap tube
GL( 818, 820 ) = CNDFNC(3,K_HPCU1) * 5.00D-06 / 0.05D0; #shunt
strap

GL( 819, 803 ) = CNDFNC(3,K_KEV29) * 3.1416D-06 / 0.031D0; #evap
conducted parasitic
GL( 817, 803 ) = CNDFNC(3,K_KEV29) * 3.1416D-06 / 0.037D0; #pump
conducted parasitic

# Evap
GL( 819, 820 ) = CNDFNC(3,K_TI6AL4V) * 2.2305D-06 / 0.05D0; #evap
heat switch conducted parasitic
GL( 819, 820 ) = HS_EVAP_GAS; #evap
heat switch He cond
GR( 819, 820 ) = 0.1D0 * 0.6619D-03; #evap HS
radiation parasitic

GL( 820, 803 ) = CNDFNC(3,K_TI6AL4V) * 1.16D-05 / 0.027D0; #evap
heat switch support from L1

# Pump
GL( 821, 817 ) = CNDFNC(3,K_TI6AL4V) * 2.2305D-06 / 0.05D0; #pump
heat switch conducted parasitic
GL( 821, 817 ) = HS_PUMP_GAS; #pump
heat switch He cond
GR( 821, 817 ) = 0.1D0 * 0.6619D-03; #pump HS
radiation parasitic

GL( 821, 803 ) = CNDFNC(3,K_TI6AL4V) * 1.16D-05 / 0.027D0; #pump
heat switch support from L1

# SPIRE Level 0 Straps Architecture
#-----

GL( 814 , 811 ) = 0.15D0; # SPIRE L0 enclosure strap
GL( 815 , 812 ) = 0.15D0; # SPIRE L0 pump strap
GL( 816 , 813 ) = 0.30D0; # SPIRE L0 evap strap

# L0 Strap Supports off SOB - 3 Straps with 2 supp each, with 2 foot per support
GL( 811 , 803 ) = 2.0D0 * CNDFNC(3,K_VES)*2.0D0*0.005D0*0.005D0/0.030D0;
GL( 812 , 803 ) = 2.0D0 * CNDFNC(3,K_VES)*2.0D0*0.005D0*0.005D0/0.030D0;
GL( 813 , 803 ) = 2.0D0 * CNDFNC(3,K_VES)*2.0D0*0.005D0*0.005D0/0.030D0;

# SPIRE Internal L0 Flexible Straps

GL( 811 , 810 ) = 0.15D0; #L0 enclosure
GL( 812 , 821 ) = 0.15D0; #L0 pump
GL( 813 , 820 ) = 0.30D0; #L0 evaporator

# SPIRE Internal L0 Strap between the spectrometer and the photometer enclsoures
GL( 810, 809 ) = U;

```

```
GL( 822, 819 ) = U; #cooler-ph detector strap effective A
GL( 823, 819 ) = U; #cooler-sp detector strap effective A
```

```
# SPIRE Level 1 Strap Interface
```

```
#-----
```

```
# Level 1 strap electrical insulation joint conductance - Copper/Epoxy/Copper Joint with 13
cm2 contact area
```

```
# The 0.425 factor has been added to achieve a sensible SOB mean Temperature
```

```
GL( 803 , 800 ) = (0.425) * 0.107;
```

```
GL( 803 , 830 ) = (0.425) * 0.107;
```

```
$CONSTANTS
```

```
#=====
```

```
$CHARACTER
```

```
GPLTO = 'O'; # initialize switch for phase to be run (global constant) For integratin
within HERSCHEL
```

```
MODE = 'SWITCH_OFF';
```

```
HS_EVAP_STATE = 'OFF';
```

```
HS_PUMP_STATE = 'OFF';
```

```
$INTEGER
```

```
IMODE = 0; # initialize switch for dissipation mode (global constant) For integratin
within HERSCHEL
```

```
#
```

```
SPSUBMD = 0; # kw: initialize switch for dissipation sub-mode for SPIRE timeline
```

```
$REAL
```

```
# To Be Selected by the user before pre-processing the model
```

```
# Margin factor applied on the SPIRE Mechanisms Internal dissipation
```

```
#
```

```
margin_fac = 1.2D0;
```

```
PI = 3.141592654D0;
```

```
#POWERS
```

```
#
```

```
q_jfet_phot = 0.0420D0;
```

```
q_jfet_spec = 0.0141D0;
```

```
q_peak_phot_calib = 0.004D0;
```

```
q_mean_phot_calib = 0.000033D0;
```

```
q_peak_spec_calib = 0.0072D0;
```

```
q_mean_spec_calib = 0.00525D0;
```

```
q_hold_spec_calib = 0.004D0;
```

```
q_peak_phot_bsm = 0.003D0;
```

```
q_mean_phot_bsm = 0.0019D0;
```

```
q_peak_phot_bsm2 = 0.0002D0;
```

```
q_mean_phot_bsm2 = 0.0002D0;
```

```
q_peak_spec_mech = 0.0032D0;
```

```
q_mean_spec_mech = 0.00205D0;
```

```
q_min_spec_mech = 0.0009D0;
```

```

q_cooler_hs      = 0.0002D0;

q_evap_rc       = 0.00579D0;

q_shunt_nom     = 0.0000054D0;
q_shunt_rc1    = 0.0578D0;
q_shunt_rc2    = 0.0069D0;

q_pump_nom      = 0.0015D0;
q_pump_add     = 0.0D0;
q_pump1        = 0.200D0;
q_pump2        = 0.025D0;
q_pump_rc      = 0.0579D0;
q_pump_cd      = 0.01707D0;

```

Average Load Definition

```

#
q_pump_avr     = 0.001106D0;
q_shunt_avr    = 0.000222D0;
q_evap_avr     = 0.000040D0;
q_evap_hs_avr  = 0.000001D0;
q_pump_hs_avr  = 0.000065D0;
q_pcal         = 0.000011D0;
q_bsm         = 0.000424D0;
q_smecm       = 0.000328D0;
q_scal        = 0.000840D0;
q_pjfet_avr   = 0.006722D0;
q_sjfet_avr   = 0.002257D0;

```

#Heat Switch Gas Conductance - Calculated in \$VARIABLES1

```

#
HS_PUMP_GAS    = 0.0D0;
HS_EVAP_GAS    = 0.0D0;

```

Cooler Heat Loads - Calculated in \$VARIABLES1

```

#
Photo_load     = 0.0D0;           # in microwatts
Spectro_load   = 0.0D0;           # in microwatts
Parasitic_load = 0.0D0;           # in microwatts - Evap only
Tot_Cooler_load = 0.0D0;          # in microwatts
Tot_Cooler_Energy = 0.0D0;

```

Cooler Hold Time Routine - Calculated in \$VARIABLES2

```

#
Latent_evap    = 0.0D0;           # In J/g
He_Mend_Minit  = 0.0D0;
Mass_He_Final  = 0.0D0;
Cooler_hold    = 0.0D0;           # in hrs

```

\$ARRAYS

#=====

\$REAL

```

#####
#####
# SPIRE Material Specific Heat (J/kg/K)
#####
#####
#
# SPECIFIC HEAT - Aluminium
#
SHCAL1(2,19)=
1.1,      0.1332,

```

```
2.0D0, 0.1148,
4.0D0, 0.2830,
10.0D0, 1.40D0,
15.0D0, 3.84D0,
18.0D0, 6.49D0,
19.0D0, 7.62D0,
20.0D0, 8.90D0,
21.0D0, 10.30D0,
22.0D0, 11.90D0,
23.0D0, 13.70D0,
24.0D0, 15.70D0,
25.0D0, 17.80D0,
27.0D0, 22.60D0,
30.0D0, 31.50D0,
50.0D0, 142.00D0,
100.0D0, 481.00D0,
200.0D0, 797.00D0,
300.0D0, 902.00D0;
#
#
# SPECIFIC HEAT - Copper
#
SHCCU1(2,10)=
0.2D0, 0.0006D0,
0.3D0, 0.0006D0,
1.0D0, 0.012D0,
4.0D0, 0.091D0,
10.0D0, 0.86D0,
20.0D0, 7.7D0,
50.0D0, 99.0D0,
100.0D0, 250.0D0,
200.0D0, 360.0D0,
300.0D0, 390.0D0;
#
# SPECIFIC HEAT - Invar
#
SHCIN1(2,10)=
0.2D0, 0.096D0,
0.3D0, 0.096D0,
1.0D0, 0.24D0,
4.0D0, 0.57D0,
10.0D0, 3.1D0,
20.0D0, 12.0D0,
50.0D0, 120.0D0,
100.0D0, 310.0D0,
200.0D0, 440.0D0,
300.0D0, 470.0D0;
#
# SPECIFIC HEAT - Silicon
#
SHCSI1(2,10)=
0.2D0, 0.000001D0,
0.3D0, 0.000001D0,
1.0D0, 0.000066D0,
4.0D0, 0.017D0,
10.0D0, 0.28D0,
20.0D0, 8.5D0,
50.0D0, 79.0D0,
100.0D0, 260.0D0,
200.0D0, 560.0D0,
300.0D0, 710.0D0;
#
# SPECIFIC HEAT - Titanium
#
SHCTI1(2,10)=
0.2D0, 0.0071D0,
0.3D0, 0.0071D0,
1.0D0, 0.071D0,
4.0D0, 0.317D0,
10.0D0, 1.26D0,
20.0D0, 7.0D0,
50.0D0, 99.2D0,
```



```

100.0D0,    300.0D0,
200.0D0,    465.0D0,
300.0D0,    522.0D0;
#
# SPECIFIC HEAT - Stainless Steel
#
SHCSS1(2,10)=
0.2D0,      0.02D0,
0.3D0,      0.020D0,
1.0D0,      0.090D0,
4.0D0,      0.382D0,
10.0D0,     1.24D0,
20.0D0,     4.5D0,
50.0D0,     55.0D0,
100.0D0,    216.0D0,
200.0D0,    384.0D0,
300.0D0,    447.0D0;
#
#
#####
#####
# SPIRE Material Thermal Conductivity (W/mK)
#####
#####
#
#
# Brass
#
K_BRASS(2,15) =
0.1D0,      0.065D0,
0.2D0,      0.13D0,
0.3D0,      0.20D0,
0.4D0,      0.28D0,
0.5D0,      0.32D0,
0.6D0,      0.39D0,
0.7D0,      0.43D0,
0.8D0,      0.50D0,
1.0D0,      0.7D0,
4.0D0,      3.0D0,
10.0D0,     10.0D0,
40.0D0,     37.0D0,
80.0D0,     65.0D0,
150.0D0,    85.0D0,
300.0D0,    120.0D0;
#
# Constantan - 60% Cu - 40% Ni&55% Cu - 45% Ni
#
K_CONSTANTAN(2,26) =
0.1D0,      0.006D0,
0.4D0,      0.02D0,
1.0D0,      0.1D0,
4.0D0,      0.8D0,
5.0D0,      1.2D0,
6.0D0,      1.6D0,
7.0D0,      2.0D0,
8.0D0,      2.5D0,
9.0D0,      3.0D0,
10.0D0,     3.5D0,
15.0D0,     6.3D0,
20.0D0,     8.5D0,
30.0D0,     12.0D0,
40.0D0,     14.0D0,
50.0D0,     15.0D0,
60.0D0,     16.0D0,
70.0D0,     16.5D0,
80.0D0,     17.0D0,
140.0D0,    17.5D0,
150.0D0,    17.8D0,
160.0D0,    18.0D0,
180.0D0,    18.2D0,
190.0D0,    18.5D0,
200.0D0,    19.0D0,

```

```
250.0D0, 21.0D0,
300.0D0, 22.5D0;
#
# Copper - CG-OFC ultra high purity
#
K_HPCU1(2,10) =
0.2D0, 100.0D0,
0.3D0, 100.0D0,
1.0D0, 400.0D0,
4.0D0, 1500.0D0,
10.0D0, 3600.0D0,
20.0D0, 4400.0D0,
50.0D0, 1300.0D0,
100.0D0, 550.0D0,
200.0D0, 420.0D0,
300.0D0, 420.0D0;
#
# Helium 3
#
He3(2,24)=
0.3D0, 0.003D0,
1.0D0, 0.0075D0,
2.0D0, 0.0117D0,
3.0D0, 0.0128D0,
4.0D0, 0.0135D0,
5.0D0, 0.016132188D0,
10.0D0, 0.022801491D0,
15.0D0, 0.028331647D0,
20.0D0, 0.033272474D0,
25.0D0, 0.037823528D0,
30.0D0, 0.042087113D0,
35.0D0, 0.046125065D0,
40.0D0, 0.049978604D0,
45.0D0, 0.053677057D0,
50.0D0, 0.057242285D0,
55.0D0, 0.060691168D0,
60.0D0, 0.064037101D0,
65.0D0, 0.067290951D0,
70.0D0, 0.070461696D0,
75.0D0, 0.073556864D0,
80.0D0, 0.076582854D0,
100.0D0,0.088094754D0,
200.0D0,0.136670461D0,
300.0D0,0.176908476D0;
#
# Kapton
#
K_KAPT(2,9)=
0.30D0, 0.00037D0,
1.0D0, 0.00110D0,
4.0D0, 0.0047D0,
10.0D0, 0.015D0,
20.0D0, 0.031D0,
50.0D0, 0.064D0,
100.0D0, 0.100D0,
200.0D0, 0.150D0,
300.0D0, 0.170D0;
#
# KEVLAR 29 THREAD
#
K_KEV29(2,40) =
0.1D0, 0.0000760D0,
0.2D0, 0.000249D0,
0.3D0, 0.000498D0,
0.4D0, 0.000814D0,
0.5D0, 0.00119D0,
0.6D0, 0.00163D0,
0.7D0, 0.00212D0,
0.8D0, 0.00266D0,
0.9D0, 0.00326D0,
1.0D0, 0.00390D0,
1.1D0, 0.00459D0,
```

```
1.2D0, 0.00533D0,
1.3D0, 0.00611D0,
1.4D0, 0.00693D0,
1.5D0, 0.00780D0,
1.6D0, 0.00871D0,
1.7D0, 0.00966D0,
1.8D0, 0.0107D0,
1.9D0, 0.0117D0,
2.0D0, 0.0128D0,
3.0D0, 0.0165D0,
3.5D0, 0.0209D0,
4.0D0, 0.0256D0,
4.5D0, 0.0307D0,
5.0D0, 0.0361D0,
6.0D0, 0.0478D0,
7.0D0, 0.0607D0,
8.0D0, 0.0745D0,
9.0D0, 0.0893D0,
10.0D0, 0.1051D0,
15.0D0, 0.1962D0,
20.0D0, 0.3055D0,
30.0D0, 0.45D0,
40.0D0, 0.60D0,
50.0D0, 0.72D0,
60.0D0, 0.80D0,
70.0D0, 1.00D0,
100.0D0, 1.20D0,
200.0D0, 3.50D0,
300.0D0, 10.00D0;
#
# MANGANIN
#
K_MANGANIN(2,16) =
0.1D0, 0.00143D0,
0.4D0, 0.0122D0,
1.0D0, 0.0503D0,
2.0D0, 0.147D0,
3.0D0, 0.275D0,
4.0D0, 0.429D0,
6.0D0, 0.803D0,
8.0D0, 1.253D0,
9.3D0, 1.568D0,
10.0D0, 1.727D0,
20.0D0, 3.71D0,
40.0D0, 7.02D0,
50.0D0, 8.39D0,
100.0D0, 13.18D0,
200.0D0, 17.81D0,
300.0D0, 22.13D0;
#
# AL to AL CONTACT
#
M4COND_up(2,19) =
0.0D0, 0.0D0,
2.0D0, 0.0019D0,
4.0D0, 0.0045D0,
6.0D0, 0.0075D0,
8.0D0, 0.0108D0,
10.0D0, 0.0142D0,
20.0D0, 0.0338D0,
30.0D0, 0.0562D0,
40.0D0, 0.0805D0,
50.0D0, 0.1064D0,
60.0D0, 0.1336D0,
70.0D0, 0.1620D0,
80.0D0, 0.1914D0,
90.0D0, 0.2218D0,
102.5D0, 0.26D0,
150.0D0, 0.26D0,
200.0D0, 0.26D0,
250.0D0, 0.26D0,
300.0D0, 0.26D0;
```

```
#
# STAINLESS STEEL
#
K_SSTEEL(2,35) =
0.1D0, 0.01D0,
0.2D0, 0.03D0,
0.3D0, 0.04D0,
0.5D0, 0.08D0,
0.7D0, 0.11D0,
1.0D0, 0.08D0,
4.0D0, 0.24D0,
5.0D0, 0.32D0,
6.0D0, 0.40D0,
7.0D0, 0.48D0,
8.0D0, 0.58D0,
9.0D0, 0.66D0,
10.0D0, 0.77D0,
15.0D0, 1.30D0,
20.0D0, 1.90D0,
30.0D0, 3.25D0,
40.0D0, 4.50D0,
50.0D0, 5.75D0,
60.0D0, 6.75D0,
70.0D0, 7.50D0,
80.0D0, 8.25D0,
90.0D0, 9.00D0,
100.0D0, 9.50D0,
110.0D0, 10.00D0,
120.0D0, 10.50D0,
130.0D0, 10.75D0,
140.0D0, 11.00D0,
150.0D0, 11.50D0,
160.0D0, 11.75D0,
170.0D0, 12.00D0,
180.0D0, 12.25D0,
190.0D0, 12.50D0,
200.0D0, 13.00D0,
250.0D0, 14.00D0,
300.0D0, 15.00D0;
#
# Teflon
#
K_TEF(2,8)=
0.1D0, 0.00002D0,
0.4D0, 0.00040D0,
1.0D0, 0.00400D0,
2.0D0, 0.02000D0,
4.0D0, 0.05000D0,
10.0D0, 0.10000D0,
40.0D0, 0.20000D0,
400.0D0, 0.266D0;
#
# Torlon
#
K_TOR(2,19)=
0.1D0, 4.05005D-06,
2.0D0, 0.002777831D0,
3.0D0, 0.006723336D0,
4.0D0, 0.012587841D0,
5.02D0, 1.61D-02,
7.06D0, 1.69D-02,
10.12D0, 1.93D-02,
15.22D0, 2.60D-02,
20.32D0, 3.63D-02,
24.91D0, 4.85D-02,
30.01D0, 6.53D-02,
35.11D0, 8.57D-02,
40.21D0, 1.10D-01,
44.8D0, 1.34D-01,
49.9D0, 1.65D-01,
55.0D0, 0.1986D0,
100.0D0, 0.2367D0,
```

```
200.0D0, 0.3213D0,
293.0D0, 0.4000D0;
```

```
#
```

```
# Ti6Al4V
```

```
#
```

```
K_TI6AL4V(2,17)=
0.2D0, 0.006D0,
0.3D0, 0.006D0,
0.5D0, 0.014D0,
1.0D0, 0.043D0,
1.5D0, 0.082D0,
2.0D0, 0.130D0,
3.0D0, 0.197D0,
4.0D0, 0.253D0,
10.0D0, 0.68D0,
20.0D0, 1.32D0,
35.0D0, 2.12D0,
50.0D0, 2.75D0,
100.0D0, 4.00D0,
150.0D0, 5.00D0,
200.0D0, 5.80D0,
250.0D0, 6.60D0,
300.0D0, 7.60D0;
```

```
#
```

```
# Vespel
```

```
#
```

```
K_VES(2,15)=
0.1D0, 0.0001D0,
0.3D0, 0.00045D0,
1.0D0, 0.0018D0,
2.0D0, 0.0042D0,
4.0D0, 0.0096D0,
5.0D0, 0.0126D0,
8.0D0, 0.0223D0,
10.0D0, 0.0292D0,
15.0D0, 0.0477D0,
117.0D0, 0.047D0,
144.0D0, 0.06D0,
200.0D0, 0.085D0,
255.0D0, 0.11D0,
297.0D0, 0.129D0,
311.0D0, 0.136D0;
```

```
#
```

```
#
```

```
#####
#####
```

```
# Interfaces Conductance Arrays (W/K)
```

```
#####
#####
```

```
#
```

```
K_Cooler_IF(2,11)=
0.3D0, 0.037378921D0,
0.35D0, 0.050501804D0,
0.4D0, 0.065540111D0,
0.45D0, 0.082481565D0,
0.5D0, 0.101315412D0,
5.0D0, 0.4D0,
6.0D0, 0.5D0,
10.0D0, 0.8D0,
15.0D0, 1.0D0,
50.0D0, 1.0D0,
300.0D0, 1.0D0;
```

```
#
```

```
K_RClamp_IF(2,11)=
0.3D0, 0.045499027D0,
0.35D0, 0.05423604D0,
0.4D0, 0.063149483D0,
0.45D0, 0.072220102D0,
0.5D0, 0.081432686D0,
5.0D0, 0.4D0,
6.0D0, 0.5D0,
10.0D0, 0.8D0,
```

```

15.0D0, 1.0D0,
50.0D0, 1.0D0,
300.0D0, 1.0D0;
#
K_CuCu_IF(2,14)=
0.0D0, 0.0D0,
1.0D0, 0.08D0,
2.0D0, 0.16D0,
3.0D0, 0.24D0,
4.0D0, 0.32D0,
5.0D0, 0.40D0,
6.0D0, 0.48D0,
7.0D0, 0.56D0,
8.0D0, 0.64D0,
9.0D0, 0.72D0,
10.0D0, 0.8D0,
15.0D0, 1.0D0,
50.0D0, 1.0D0,
300.0D0, 1.0D0;
#

```

```

K_Cu_Sty_Cu_IF(2,5)=
0.3D0, 0.002051712D0,
0.35D0, 0.002919785D0,
0.4D0, 0.003963589D0,
0.45D0, 0.005190051D0,
0.5D0, 0.006605504D0;
#

```

```

Cu_E_Cu(2,3)=
1.5D0, 0.0045D0,
2.0D0, 0.0055D0,
4.0D0, 0.009D0;
#

```

```

#####
#####

```

\$SUBROUTINES

#=====

```

DOUBLE PRECISION FUNCTION SHCAL(X)
DOUBLE PRECISION X
SHCAL = INTRP1 (X,SHCAL1,1)
RETURN
END

```

```

DOUBLE PRECISION FUNCTION SHCCU(X)
DOUBLE PRECISION X
SHCCU = INTRP1 (X,SHCCU1,1)
RETURN
END

```

```

DOUBLE PRECISION FUNCTION SHCINV(X)
DOUBLE PRECISION X
SHCINV = INTRP1 (X,SHCIN1,1)
RETURN
END

```

```

DOUBLE PRECISION FUNCTION SHCSI(X)
DOUBLE PRECISION X
SHCSI = INTRP1 (X,SHCSI1,1)
RETURN
END

```

```

DOUBLE PRECISION FUNCTION SHCTI(X)
DOUBLE PRECISION X
SHCTI = INTRP1 (X,SHCTI1,1)
RETURN
END

```

```

DOUBLE PRECISION FUNCTION SHCSS(X)

```

```
DOUBLE PRECISION X
SHCSS = INTRP1 (X,SHCSS1,1)
RETURN
END
```

```

SUBROUTINE SSOPMD(ISWITCH) LANG = MORTRAN
# =====
# INTEGER ISWITCH
#
SELECT CASE ISWITCH

CASE -1 # PACS Off, SPIRE and HIFI off

MODE = 'SWITCH_OFF'

QI801 = 0.0 # Photometer JFET
QI802 = 0.0 # Spectrometer JFET
QI805 = 0.0 # BSM
QI806 = 0.0 # SMECm
QI807 = 0.0 # PCAL
QI808 = 0.0 # SCAL
QI817 = 0.0 # PUMP
QI818 = 0.0 # SHUNT
QI819 = 0.0 # EVAP
QI820 = 0.0 # HS EVAP
QI821 = 0.0 # HS PUMP

CASE 0 # Average Power dissipation for Steady State

MODE = 'SWITCH_ON'

QI801 = q_pjfet_avr # Photometer JFET
QI802 = q_sjfet_avr # Spectrometer JFET
QI805 = q_bsm # BSM
QI806 = q_smecm # SMECm
QI807 = q_pcal # PCAL
#
# Please note that due to instability problem the power dissipation has been set
to zero
# for the following node 808 - Spectrometer Calibration Source
QI808 = 0.0 # q_scal
QI803 = q_scal # Heat dissipation applied to SOB instead
#
QI817 = q_pump_avr # PUMP
QI818 = q_shunt_avr # SHUNT
QI819 = q_evap_avr # EVAP
QI820 = q_evap_hs_avr # HS EVAP
QI821 = q_pump_hs_avr # HS PUMP

CASE 1 # PACS in Spectrometer Mode, SPIRE and HIFI off

MODE = 'SWITCH_OFF'

QI801 = 0.0 # Photometer JFET
QI802 = 0.0 # Spectrometer JFET
QI805 = 0.0 # BSM
QI806 = 0.0 # SMECm
QI807 = 0.0 # PCAL
QI808 = 0.0 # SCAL
QI817 = 0.0 # PUMP
QI818 = 0.0 # SHUNT
QI819 = 0.0 # EVAP
QI820 = 0.0 # HS EVAP
QI821 = 0.0 # HS PUMP

CASE 2 # PACS in Photometer mode, HIFI and SPIRE off

MODE = 'SWITCH_OFF'
```

```

QI801 = 0.0          # Photometer JFET
QI802 = 0.0          # Spectrometer JFET
QI805 = 0.0          # BSM
QI806 = 0.0          # SMECm
QI807 = 0.0          # PCAL
QI808 = 0.0          # SCAL
QI817 = 0.0          # PUMP
QI818 = 0.0          # SHUNT
QI819 = 0.0          # EVAP
QI820 = 0.0          # HS EVAP
QI821 = 0.0          # HS PUMP

```

CASE 3 # PACS off, SPIRE Photometer mode, HIFI off

MODE = 'SWITCH_ON'

```

QI801 = q_jfet_phot      # Photometer JFET
QI802 = 0.0              # Spectrometer JFET
QI805 = q_peak_phot_bsm  # BSM
QI806 = 0.0              # SMECm
QI807 = q_mean_phot_calib # PCAL
QI808 = 0.0              # SCAL
QI817 = q_pump_nom       # PUMP
QI818 = q_shunt_nom      # SHUNT
QI819 = 0.0              # EVAP
QI820 = 0.0              # HS EVAP
QI821 = q_cooler_hs      # HS PUMP

```

CASE 4 # PACS off, SPIRE Spectrometer mode, HIFI off

MODE = 'SWITCH_ON'

```

QI801 = 0.0          # Photometer JFET
QI802 = q_jfet_spec  # Spectrometer JFET
QI805 = q_mean_phot_bsm2 # BSM
QI806 = q_peak_spec_mech # SMECm
QI807 = q_mean_phot_calib # PCAL
QI808 = q_mean_spec_calib # SCAL
QI817 = q_pump_nom    # PUMP
QI818 = q_shunt_nom   # SHUNT
QI819 = 0.0           # EVAP
QI820 = 0.0           # HS EVAP
QI821 = q_cooler_hs   # HS PUMP

```

CASE 5 # PACS off, SPIRE off, HIFI on

MODE = 'SWITCH_OFF'

```

QI801 = 0.0          # Photometer JFET
QI802 = 0.0          # Spectrometer JFET
QI805 = 0.0          # BSM
QI806 = 0.0          # SMECm
QI807 = 0.0          # PCAL
QI808 = 0.0          # SCAL
QI817 = 0.0          # PUMP
QI818 = 0.0          # SHUNT
QI819 = 0.0          # EVAP
QI820 = 0.0          # HS EVAP
QI821 = 0.0          # HS PUMP

```

CASE 6 # PACS in Photometer mode, SPIRE in Photometer Mode, HIFI off

MODE = 'SWITCH_ON'

```

QI801 = q_jfet_phot      # Photometer JFET
QI802 = 0.0              # Spectrometer JFET
QI805 = q_peak_phot_bsm  # BSM
QI806 = 0.0              # SMECm

```



```

QI807 = q_mean_phot_calib      # PCAL
QI808 = 0.0                    # SCAL
QI817 = q_pump_nom             # PUMP
QI818 = q_shunt_nom           # SHUNT
QI819 = 0.0                    # EVAP
QI820 = 0.0                    # HS EVAP
QI821 = q_cooler_hs           # HS PUMP

```

```

#
CASE ELSE
  WRITE (*,*) 'Illegal dissipation mode: ', ISWITCH
  STOP
END SELECT
#
RETURN
END

```

```

$INITIAL
#=====

```

```

# Apply margin factor to internal mechanism dissipation

```

```

q_jfet_phot      = q_jfet_phot      * margin_fac
q_jfet_spec      = q_jfet_spec      * margin_fac

q_peak_phot_calib = q_peak_phot_calib * margin_fac
q_mean_phot_calib = q_mean_phot_calib * margin_fac

q_peak_spec_calib = q_peak_spec_calib * margin_fac
q_mean_spec_calib = q_mean_spec_calib * margin_fac
q_hold_spec_calib = q_hold_spec_calib * margin_fac

q_peak_phot_bsm  = q_peak_phot_bsm  * margin_fac
q_mean_phot_bsm  = q_mean_phot_bsm  * margin_fac

q_peak_phot_bsm2 = q_peak_phot_bsm2 * margin_fac
q_mean_phot_bsm2 = q_mean_phot_bsm2 * margin_fac

q_peak_spec_mech = q_peak_spec_mech * margin_fac
q_mean_spec_mech = q_mean_spec_mech * margin_fac
q_min_spec_mech  = q_min_spec_mech  * margin_fac

q_cooler_hs      = q_cooler_hs      * margin_fac
q_shunt_nom       = q_shunt_nom       * margin_fac

q_pump_avr       = q_pump_avr       * margin_fac
q_shunt_avr       = q_shunt_avr       * margin_fac
q_evap_avr       = q_evap_avr       * margin_fac
q_evap_hs_avr    = q_evap_hs_avr    * margin_fac
q_pump_hs_avr    = q_pump_hs_avr    * margin_fac
q_pcal           = q_pcal           * margin_fac
q_bsm            = q_bsm            * margin_fac
q_smecm         = q_smecm         * margin_fac
q_scal          = q_scal          * margin_fac
q_pjjet_avr     = q_pjjet_avr     * margin_fac
q_sjjet_avr     = q_sjjet_avr     * margin_fac

```

```

$VARIABLES1
#=====

```

```

# kw: GLs defined here because of PC-ESATAN restrictions for "long" lines in
$CONDUCTORS
GL( 810, 809 ) = 1.0D0/((1.0D0/( CNDFN3(T810,T809,K_HPCU1)*9.0E-06/
&          0.198D0))+ (1.0D0/(6.0D0*CNDFN3(T810,T809,Cu_E_Cu)))+
&          (1.0D0/CNDFN3(T810,T809,K_CuCu_IF)))
GL( 822, 819 ) = 1.0D0/((1.0D0/(CNDFN3(T822,T819,K_HPCU1)*PI*
&          (0.0015D0**2.0D0)/0.130D0))+ (1.0D0/CNDFN3(T822,T819,
&          K_RClamp_IF))+ (1.0D0/(CNDFN3(T822,T819,K_Cu_Sty_Cu_IF
&          )))+(1.0D0/CNDFN3(T822,T819,K_Cooler_IF))) #cooler-ph
detector strap effective A
GL( 823, 819 ) = 1.0D0/((1.0D0/(CNDFN3(T823,T819,K_HPCU1)*PI*
&          (0.0015D0**2.0D0)/0.244D0))+ (1.0D0/CNDFN3(T823,T819,
&          K_RClamp_IF))+ (1.0D0/(CNDFN3(T823,T819,K_Cu_Sty_Cu_IF
&          )))+(1.0D0/CNDFN3(T823,T819,K_Cooler_IF))) #cooler-sp
detector strap effective A

# Cooler instrument loads (in microwatts)
#
Photo_load      = ((GL(822,819)*(T822-T819)) * 1000000.0D0)
Spectro_load    = ((GL(823,819)*(T823-T819)) * 1000000.0D0)
Parasitic_load  = ((GL(803,819)*(T803-T819) + GL(820,819)*(T820-T819) +
GL(818,819)*(T818-T819))*1000000.0D0)
Tot_Cooler_load = (Photo_load + Spectro_load + Parasitic_load)

# "Missing" Pump Internal Power Dissipation
#
q_pump_add = ((50.0D0 * Tot_Cooler_load ) / 1000000.0D0) - q_pump_nom

# Update the Heat Switches and Evaporator Status according to SPIRE Mode ON or OFF
#
IF (MODULE.EQ.'SOLVIT' .OR. MODULE.EQ.'SOLVT2' .OR. MODULE.EQ.'SOLVSM' .OR.
MODULE.EQ.'SOLVFM') THEN

  IF (MODE.EQ.'SWITCH_ON') THEN

    # During SPIRE Operation :
    # - The evaporator node 819 is always a boundary node at 0.29K
    # - The pump HS is ON
    # - The evaporator HS is OFF

    CALL STATST('N819','B')
    T819 = 0.29D0

    HS_EVAP_STATE = 'OFF'
    HS_PUMP_STATE = 'ON'

    # No power dissipation is currently defined for the node 812 within the ISWITCH
    Function because this
    # node is used as an "arithmetic" node to compensate for the "missing" power
    dissipation of the pump.
    # QI812 is updated at each iteration according to the current total cooler load
    (ie - only when SPIRE is in
    # operation).
    # The next two lines are used to update QI8012 during the Steady-State Analysis,
    but a similar approach
    # is used in Transient Analysis.
    #

    QI812 = q_pump_add

  ELSE

```

```

# SPIRE in OFF Mode :
# - The evaporator node 819 is always a diffuse node
# - The pump HS is OFF
# - The evaporator HS is OFF

CALL STATST('N819','D')

HS_EVAP_STATE = 'OFF'
HS_PUMP_STATE = 'OFF'

QI812 = 0.0

ENDIF

GOTO 199

ELSE IF (MODULE.EQ.'SLFWBK' .OR. MODULE.EQ.'SLFRWD' .OR. MODULE.EQ.'SLGEAR' .OR.
MODULE.EQ.'SLGRDJ') THEN

##kw      # Start Transient Analysis with 48 hrs of PACS Operation
##kw      # SPIRE in OFF Mode
##kw      #
##kw      IF (TIMEN.LT.(48.0D0*3600.0D0)) THEN
##kw: TIMEN control replaced by SPSUBMD control
      IF (SPSUBMD.EQ.-1) THEN

CALL STATST('N819','D')

HS_EVAP_STATE = 'OFF'
HS_PUMP_STATE = 'OFF'

QI801 = 0.0D0      # Photometer JFET
QI802 = 0.0D0      # Spectrometer JFET
QI805 = 0.0D0      # BSM
QI806 = 0.0D0      # SMECm
QI807 = 0.0D0      # PCAL
QI808 = 0.0D0      # SCAL
QI812 = 0.0D0      # Additional "Pump" Power Dissipation
QI817 = 0.0D0      # PUMP
QI818 = 0.0D0      # SHUNT
QI819 = 0.0D0      # EVAP
QI820 = 0.0D0      # HS EVAP
QI821 = 0.0D0      # HS PUMP
##kw      GOTO 140

##kw      for simulating transient run with average dissipation:
      ELSE IF (SPSUBMD.EQ.0) THEN

CALL STATST('N819','B')
T819 = 0.29D0

HS_EVAP_STATE = 'OFF'
HS_PUMP_STATE = 'ON'
QI812 = q_pump_add

CALL SSOPMD(0)

##kw      # Start SPIRE Recycling after 48 hrs of PACS Operation
##kw      #
##kw      ELSE IF (TIMEN.LT.(48.0D0*3600.0D0+5.0D0)) THEN
      ELSE IF (SPSUBMD.EQ.1) THEN

HS_EVAP_STATE = 'ON'
HS_PUMP_STATE = 'OFF'

QI801 = 0.0D0      # Photometer JFET
QI802 = 0.0D0      # Spectrometer JFET
QI805 = 0.0D0      # BSM

```

```

QI806 = 0.0D0          # SMECm
QI807 = 0.0D0          # PCAL
QI808 = 0.0D0          # SCAL
QI812 = 0.0D0          # Additional "Pump" Power Dissipation
QI817 = 0.0D0          # PUMP
QI818 = 0.0D0          # SHUNT
QI819 = 0.0D0          # EVAP
QI820 = q_cooler_hs    # HS EVAP
QI821 = 0.0D0          # HS PUMP
##kw      GOTO 140

##kw      ELSE IF (TIMEN.LT.(48.0D0*3600.0D0+1500.0D0)) THEN
ELSE IF (SPSUBMD.EQ.2) THEN

HS_EVAP_STATE = 'ON'
HS_PUMP_STATE = 'OFF'

QI801 = 0.0D0          # Photometer JFET
QI802 = 0.0D0          # Spectrometer JFET
QI805 = 0.0D0          # BSM
QI806 = 0.0D0          # SMECm
QI807 = 0.0D0          # PCAL
QI808 = 0.0D0          # SCAL
QI812 = 0.0D0          # Additional "Pump" Power Dissipation
QI817 = q_pump1 - q_pump_rc # PUMP
QI818 = q_shunt_rc1     # SHUNT
QI819 = q_evap_rc      # EVAP
QI820 = q_cooler_hs    # HS EVAP
QI821 = 0.0D0          # HS PUMP
##kw      GOTO 140

##kw      ELSE IF (TIMEN.LT.(48.0D0*3600.0D0+3300.0D0)) THEN
ELSE IF (SPSUBMD.EQ.3) THEN

HS_EVAP_STATE = 'ON'
HS_PUMP_STATE = 'OFF'

QI801 = 0.0D0          # Photometer JFET
QI802 = 0.0D0          # Spectrometer JFET
QI805 = 0.0D0          # BSM
QI806 = 0.0D0          # SMECm
QI807 = 0.0D0          # PCAL
QI808 = 0.0D0          # SCAL
QI812 = 0.0D0          # Additional "Pump" Power Dissipation
QI817 = q_pump2        # PUMP
QI818 = q_shunt_rc2    # SHUNT
QI819 = q_evap_rc      # EVAP
QI820 = q_cooler_hs    # HS EVAP
QI821 = 0.0D0          # HS PUMP
##kw      GOTO 140

##kw      ELSE IF (TIMEN.LT.(48.0D0*3600.0D0+3301.0D0)) THEN
ELSE IF (SPSUBMD.EQ.4) THEN

HS_EVAP_STATE = 'ON'
HS_PUMP_STATE = 'OFF'

QI801 = 0.0D0          # Photometer JFET
QI802 = 0.0D0          # Spectrometer JFET
QI805 = 0.0D0          # BSM
QI806 = 0.0D0          # SMECm
QI807 = 0.0D0          # PCAL
QI808 = 0.0D0          # SCAL
QI812 = 0.0D0          # Additional "Pump" Power Dissipation
QI817 = 0.0D0          # PUMP
QI818 = 0.0D0          # SHUNT
QI819 = 0.0D0          # EVAP
QI820 = q_cooler_hs    # HS EVAP
QI821 = 0.0D0          # HS PUMP
##kw      GOTO 140

```

```

##kw      ELSE IF (TIMEN.LT.(48.0D0*3600.0D0+3302.0D0)) THEN
          ELSE IF (SPSUBMD.EQ.5) THEN

          HS_EVAP_STATE = 'OFF'
          HS_PUMP_STATE = 'ON'

          QI801 = 0.0D0      # Photometer JFET
          QI802 = 0.0D0      # Spectrometer JFET
          QI805 = 0.0D0      # BSM
          QI806 = 0.0D0      # SMECm
          QI807 = 0.0D0      # PCAL
          QI808 = 0.0D0      # SCAL
          QI812 = 0.0D0      # Additional "Pump" Power Dissipation
          QI817 = 0.0D0      # PUMP
          QI818 = 0.0D0      # SHUNT
          QI819 = 0.0D0      # EVAP
          QI820 = 0.0D0      # HS EVAP
          QI821 = q_cooler_hs # HS PUMP
##kw      GOTO 140

##kw      ELSE IF (TIMEN.LT.(48.0D0*3600.0D0+5400.0D0)) THEN
          ELSE IF (SPSUBMD.EQ.6) THEN

          CALL STATST('N819','B')

          IF (T819.GT.0.29D0) THEN

          T819 = T819 - (DTIMEU*0.00175D0) # 0.00175K/sec is the evaporator approximated
          cooldown rate during recycling

          QI817= q_pump_cd      # PUMP
          QI818= 0.0D0          # SHUNT
          QI819= 0.0D0          # EVAP

          ELSE

          T819 = 0.29D0

          QI817= q_pump_nom      # PUMP
          QI818= q_shunt_nom     # SHUNT
          QI819= 0.0D0          # EVAP

          END IF

          HS_EVAP_STATE = 'OFF'
          HS_PUMP_STATE = 'ON'

          QI801 = 0.0D0      # Photometer JFET
          QI802 = 0.0D0      # Spectrometer JFET
          QI805 = 0.0D0      # BSM
          QI806 = 0.0D0      # SMECm
          QI807 = 0.0D0      # PCAL
          QI808 = 0.0D0      # SCAL
          QI812 = 0.0D0      # Additional "Pump" Power Dissipation
          QI820 = 0.0D0      # HS EVAP
          QI821 = q_cooler_hs # HS PUMP
##kw      GOTO 140

# End of SPIRE Recycling - Evaporator Node is now a Boundary Node at 0.29K
# Start of SPIRE Operation in Spectrometer MODE - 12 hrs in SMECm R=1000
#
##kw      ELSE IF (TIMEN.LT.221400.0) THEN
          ELSE IF (SPSUBMD.EQ.7) THEN

          CALL STATST('N819','B')
          T819 = 0.29D0

          HS_EVAP_STATE = 'OFF'
          HS_PUMP_STATE = 'ON'

```

```

    QI801 = 0.0           # Photometer JFET
    QI802 = q_jfet_spec  # Spectrometer JFET
    QI805 = q_mean_phot_bsm2 # BSM
    QI806 = q_peak_spec_mech # SMECM
    QI807 = q_mean_phot_calib # PCAL
    QI808 = q_mean_spec_calib # SCAL
    QI812 = q_pump_add    # Additional "Pump" Power Dissipation
    QI817 = q_pump_nom    # PUMP
    QI818 = q_shunt_nom   # SHUNT
    QI819 = 0.0D0        # EVAP
    QI820 = 0.0D0        # HS EVAP
    QI821 = q_cooler_hs  # HS PUMP
##kw      GOTO 140

# Spectrometer Mode - 12 hrs in SMECM R=10
#
##kw      ELSE IF (TIMEN.LT.264600.0) THEN
        ELSE IF (SPSUBMD.EQ.8) THEN

        CALL STATST('N819','B')
        T819 = 0.29D0

        HS_EVAP_STATE = 'OFF'
        HS_PUMP_STATE = 'ON'

        QI801 = 0.0           # Photometer JFET
        QI802 = q_jfet_spec  # Spectrometer JFET
        QI805 = q_mean_phot_bsm2 # BSM
        QI806 = q_min_spec_mech # SMECM
        QI807 = q_mean_phot_calib # PCAL
        QI808 = q_mean_spec_calib # SCAL
        QI812 = q_pump_add    # Additional "Pump" Power Dissipation
        QI817 = q_pump_nom    # PUMP
        QI818 = q_shunt_nom   # SHUNT
        QI819 = 0.0D0        # EVAP
        QI820 = 0.0D0        # HS EVAP
        QI821 = q_cooler_hs  # HS PUMP
##kw      GOTO 140

# Change of Operation Mode for Photometer Mode - 11.5 hrs with BSM in chopping mode
#
##kw      ELSE IF (TIMEN.LT.306000.0) THEN
        ELSE IF (SPSUBMD.EQ.9) THEN

        CALL STATST('N819','B')
        T819 = 0.29D0

        HS_EVAP_STATE = 'OFF'
        HS_PUMP_STATE = 'ON'

        QI801 = q_jfet_phot  # Photometer JFET
        QI802 = 0.0           # Spectrometer JFET
        QI805 = q_mean_phot_bsm # BSM
        QI806 = 0.0           # SMECM
        QI807 = q_mean_phot_calib # PCAL
        QI808 = 0.0           # SCAL
        QI812 = q_pump_add    # Additional "Pump" Power Dissipation
        QI817 = q_pump_nom    # PUMP
        QI818 = q_shunt_nom   # SHUNT
        QI819 = 0.0D0        # EVAP
        QI820 = 0.0D0        # HS EVAP
        QI821 = q_cooler_hs  # HS PUMP
##kw      GOTO 140

# SPIRE Operation
# Photometer Mode - 11 hrs with BSM in scanning mode
#
##kw      ELSE IF (TIMEN.LT.345600.0) THEN
        ELSE IF (SPSUBMD.EQ.10) THEN

```

```

CALL STATST('N819','B')
T819 = 0.29D0

HS_EVAP_STATE = 'OFF'
HS_PUMP_STATE = 'ON'

QI801 = q_jfet_phot          # Photometer JFET
QI802 = 0.0                  # Spectrometer JFET
QI805 = q_peak_phot_bsm     # BSM
QI806 = 0.0                  # SMECM
QI807 = q_mean_phot_calib   # PCAL
QI808 = 0.0                  # SCAL
QI812 = q_pump_add           # Additional "Pump" Power Dissipation
QI817 = q_pump_nom           # PUMP
QI818 = q_shunt_nom         # SHUNT
QI819 = 0.0D0               # EVAP
QI820 = 0.0D0               # HS EVAP
QI821 = q_cooler_hs         # HS PUMP
##kw      GOTO 140

##kw      # SPIRE End of Operation after nominal 48 hrs
##kw      # SPIRE in OFF Mode - Evaporator Node is now diffuse again
##kw      #
##kw      ELSE IF (TIMEN.GT.345600.0) THEN
##kw
##kw      CALL STATST('N819','D')
##kw
##kw      HS_EVAP_STATE = 'OFF'
##kw      HS_PUMP_STATE = 'OFF'
##kw
##kw      QI801 = 0.0D0        # Photometer JFET
##kw      QI802 = 0.0D0        # Spectrometer JFET
##kw      QI805 = 0.0D0        # BSM
##kw      QI806 = 0.0D0        # SMECM
##kw      QI807 = 0.0D0        # PCAL
##kw      QI808 = 0.0D0        # SCAL
##kw      QI812 = 0.0D0        # Additional "Pump" Power Dissipation
##kw      QI817 = 0.0D0        # PUMP
##kw      QI818 = 0.0D0        # SHUNT
##kw      QI819 = 0.0D0        # EVAP
##kw      QI820 = 0.0D0        # HS EVAP
##kw      QI821 = 0.0D0        # HS PUMP
##kw      GOTO 140

      END IF

##kw 140 CONTINUE

      ENDIF

199 CONTINUE

# Set 3He Cooler Heat Switch Conductance according to their Status - ON or OFF
#
IF (HS_PUMP_STATE.EQ.'ON') THEN
  HS_PUMP_GAS = 0.00061D0 * INTRP1( ((T821+T817)/2.0D0),He3,1 ) / 0.0001D0
ELSE IF (HS_PUMP_STATE.EQ.'OFF') THEN
  HS_PUMP_GAS = 0.0D0
ENDIF
#
IF (HS_EVAP_STATE.EQ.'ON') THEN
  HS_EVAP_GAS = 0.00061D0 * INTRP1( ((T819+T820)/2.0D0),He3,1 ) / 0.0001D0
ELSE IF (HS_EVAP_STATE.EQ.'OFF') THEN
  HS_EVAP_GAS = 0.0D0
ENDIF

```

\$VARIABLES2

GENMOR

```
# Cooler Hold Time Calculation
#
Latent_evap = -0.35237 * T819**4.0 + 1.3146 * T819**3.0 -2.9039 * T819**2 + 7.7264
* T819 + 6.6193
# In J/g
He_Mend_Minit = ((2.718281828**((0.012468 * T819**3 -0.025872 * T819**2
+0.12744*T819)))/(2.718281828**((0.012468 * T817**3 -0.025872 * T817**2 +0.12744*T817)))
Mass_He_Final = 0.91D0 * 0.000807857D0 * He_Mend_Minit
Cooler_hold = (Latent_evap * 1000.0D0 * Mass_He_Final) / ((Tot_Cooler_load/1000000)
* 3600.0D0)
```

\$EXECUTION

#=====

\$OUTPUTS

#=====

\$ENDMODEL

#=====

SPIRE IIDB issue 3.2 - ANNEX

Annex 3

Summary of SPIRE cryoharness wiring functions

Name	128 Way Connector	FPU/JFS/JFP Connector Label	Unit Connector Type	Harness Connector Label	Harness Connector Type	Description	Number of Conductors excl. shields	Number* inner Shields	Implementation	Max. R (W)	Impedance C(pF)	L(uH)	Max.Current in A. per Conductor	Av. Current in A per Conductor	Max. Volts
C1 Type 3	CVV 1	HSJFS J5	MDM 25 P	HSJFS P5	MDM 25 S	Bolometer signals from JFS (SLW 1-12)	24	3	DS 12-ax	500	1000pF	0.08uH	1.0E-09	5.0E-10	0.1
						Anti-cross talk ground wires.	12	NA		500	1000pF	0.08uH	0.0E+00	0.0E+00	0.1
						Cable Level Shields†	0	3	>80%						
		HSJFS J6	MDM 25 P	HSJFS P6	MDM 25S	Bolometer signals from JFS (SLW 13-24)	24	3	DS 12-ax	500	1000pF	0.08uH	1.0E-09	5.0E-10	0.1
						Anti-cross talk ground wires.	12	NA		500	1000pF	0.08uH	0.0E+00	0.0E+00	0.1
						Cable Level Shields†	0	3	>80%						
		HSJFS J9	MDM 37 S	HSJFS P9	MDM 37P	PTC Bias	2	1	DSTP	200	1000pF	0.08	3.2E-08	8.0E-09	10
						PTC Ground wire	1	0	S	50	1000pF	0.08uH	0	0	10
						PTC JFET Bias	2	1	DSTP	100	1000pF	0.08uH	5.0E-03	2.0E-04	10
						SLW Bolometer Bias	4	2	DSTP	200	1000pF	0.08uH	9.6E-08	2.4E-08	10
						SLW JFET Bias	4	2	DSTP	100	1000pF	0.08uH	2.5E-03	6.0E-04	10
						SLW Ground wire	1	0	S	50	1000pF	0.08uH	0	0	10
						SSW Bolometer Bias	4	2	DSTP	200	1000pF	0.08uH	1.2E-03	4.8E-08	10
						SSW JFET Bias	4	2	DSTP	100	1000pF	0.08uH	5.0E-03	1.2E-03	10
						SSW Ground Wire	1	0	S	50	1000pF	0.08uH	0	0	10
						PTC JFET Heater	2	1	DSTP	200	1000pF	0.08uH	1.9E-03	4.8E-04	10
						SLW JFET Heater	2	1	DSTP	200	1000pF	0.08uH	3.3E-03	8.3E-04	10
						SSW JFET Heater	2	1	DSTP	200	1000pF	0.08uH	6.7E-03	1.7E-03	10
						Cable Level Shields†	0	13	>80%						
						HSJFS J10	MDM 37 S	HSJFS P10	MDM 37P	PTC Bias	2	1	DSTP	200	1000pF
PTC Ground wire	1	0	S	50	1000pF					0.08uH	0	0	10		
PTC JFET Bias	2	1	DSTP	100	1000pF					0.08uH	5.0E-03	2.0E-04	10		
SLW Bolometer Bias	4	2	DSTP	200	1000pF					0.08uH	9.6E-08	2.4E-08	10		
SLW JFET Bias	4	2	DSTP	100	1000pF					0.08uH	2.5E-03	6.0E-04	10		
SLW Ground wire	1	0	S	50	1000pF					0.08uH	0	0	10		
SSW Bolometer Bias	4	2	DSTP	200	1000pF					0.08uH	1.2E-03	4.8E-08	10		
SSW JFET Bias	4	2	DSTP	100	1000pF					0.08uH	5.0E-03	1.2E-03	10		
SSW Ground Wire	1	0	S	50	1000pF					0.08uH	0	0	10		
PTC JFET Heater	2	1	DSTP	200	1000pF					0.08uH	1.9E-03	4.8E-04	10		
SLW JFET Heater	2	1	DSTP	200	1000pF					0.08uH	3.3E-03	8.3E-04	10		
SSW JFET Heater	2	1	DSTP	200	1000pF					0.08uH	6.7E-03	1.7E-03	10		
Cable Level Shields†	0	13	>80%												
C2 Type4	CVV 2	HSJFS J7	MDM 25 P	HSJFS P7	MDM 25S					Bolometer signals from JFS (300-mK TC 1-3)	8	1	DS 12-ax	500	1000pF
						Anti-cross talk ground wires.	4	NA		500	1000pF	0.08uH	0.0E+00	0.0E+00	0.1
						Cable Level Shields†	0	1	>80%						
		HSJFS J1	MDM 25 P	HSJFS P1	MDM 25S	Bolometer signals from JFS (SSW 1-12)	24	3	DS 12-ax	500	1000pF	0.08uH	1.0E-09	5.0E-10	0.1
						Anti-cross talk ground wires.	12	NA		500	1000pF	0.08uH	0.0E+00	0.0E+00	0.1
						Cable Level Shields†	0	3	>80%						
		HSJFS J2	MDM 25 P	HSJFS P2	MDM 25S	Bolometer signals from JFS (SSW 13-24)	24	3	DS 12-ax	500	1000pF	0.08uH	1.0E-09	5.0E-10	0.1
						Anti-cross talk ground wires.	12	NA		500	1000pF	0.08uH	0.0E+00	0.0E+00	0.1
						Cable Level Shields†	0	3	>80%						
		HSJFS J3	MDM 25 P	HSJFS P3	MDM 25S	Bolometer signals from JFS (SSW 25-36)	24	3	DS 12-ax	500	1000pF	0.08uH	1.0E-09	5.0E-10	0.1
Anti-cross talk ground wires.	12					NA		500	1000pF	0.08uH	0.0E+00	0.0E+00	0.1		
Cable Level Shields†	0					3	>80%								
HSJFS J4	MDM 25 P	HSJFS P4	MDM 25S	Bolometer signals from JFS (SSW 37-42)	16	2	DS 12-ax	500	1000pF	0.08uH	1.0E-09	5.0E-10	0.1		
				Anti-cross talk ground wires.	8	NA		500	1000pF	0.08uH	0.0E+00	0.0E+00	0.1		
				Cable Level Shields†	0	2	>80%								
C3	HSJFP J25	MDM 37 S	JFP P25	MDM 37P	PSW JFET Bias	12	6	DSTP	100	1000pF	0.08uH	5.0E-03	1.2E-03	10	
					PSW Ground	1	0	S	50	1000pF	0.08uH	0	0	10	
					PSW Bolometer Bias	6	3	DSTP	200	1000pF	0.08uH	3.8E-07	9.6E-08	10	
					PSW Heater	6	3	DSTP	200	1000pF	0.08uH	3.8E-03	9.6E-04	10	
	Cable Level Shields†	0	12	>80%											
	HSJFP J27	MDM 37 S	JFP P27	MDM 37P	PMW JFET Bias	8	4	DSTP	100	1000pF	0.08uH	5.0E-03	1.2E-03	10	
					PMW Bolometer Bias	4	2	DSTP	200	1000pF	0.08uH	3.8E-07	9.6E-08	10	
					PMW Ground	1	0	S	50	1000pF	0.08uH	0	0	10	
					PMW JFET Heater	4	2	DSTP	200	1000pF	0.08uH	3.8E-03	9.6E-04	10	
					PLW JFET Heater	2	1	DSTP	200	1000pF	0.08uH	3.8E-03	9.6E-04	10	
					PLW JFET Bias	4	2	DSTP	100	1000pF	0.08uH	5.0E-03	1.2E-03	10	
					PLW Bolometer Bias	4	2	DSTP	200	1000pF	0.08uH	1.9E-07	4.8E-08	10	
					PLW Ground	1	0	S	50	1000pF	0.08uH	0	0	10	
					Cable Level Shields†	0	13	>80%							
					HSJFP J26	MDM 37 S	JFP P26	MDM 37P	PSW JFET Bias	12	6	DSTP	100	1000pF	0.08uH
	PSW Ground	1	0	S					50	1000pF	0.08uH	0	0.0E+00	10	
	PSW Bolometer Bias	6	3	DSTP					200	1000pF	0.08uH	3.8E-07	9.6E-08	10	
	PSW Heater	6	3	DSTP					200	1000pF	0.08uH	3.8E-03	9.6E-04	10	
	Cable Level Shields†	0	12	>80%											
HSJFP J28	MDM 37 S	JFP P28	MDM 37P	PMW JFET Bias	8	4	DSTP	100	1000pF	0.08uH	5.0E-03	1.2E-03	10		
				PMW Bolometer Bias	4	2	DSTP	200	1000pF	0.08uH	3.8E-07	9.6E-08	10		
				PMW Ground	1	0	S	50	1000pF	0.08uH	0.0E+00	0.0E+00	10		
				PMW JFET Heater	4	2	DSTP	200	1000pF	0.08uH	3.8E-03	9.6E-04	10		
				PLW JFET Heater	2	1	DSTP	200	1000pF	0.08uH	3.8E-03	9.6E-04	10		
				PLW JFET Bias	4	2	DSTP	100	1000pF	0.08uH	5.0E-03	1.2E-03	10		
				PLW Bolometer Bias	4	2	DSTP	200	1000pF	0.08uH	1.9E-07	4.8E-08	10		
				PLW Ground	1	0	S	50	1000pF	0.08uH	0.0E+00	0.0E+00	10		
				Cable Level Shields†	0	13	>80%								



Name	128 Way Connector	FPU/JFS/JFP Connector Label	Unit Connector Type	Harness Connector Label	Harness Connector Type	Description	Number of Conductors excl. shields	Number* inner Shields	Implementation	Max. R (W)	Impedance C(pF)	L(uH)	Max.Current in A. per Conductor	Av. Current in A per Conductor	Max. Volts
C4	CVV 4	HSJFP J21	MDM 25 P	HSJFP P21	MDM 25S	Bolometer signals from JFP (PMW 1-12)	24	3	DS 12-ax	500	1000pF	0.08uH	1.0E-09	5.0E-10	0.1
						Anti-cross talk ground wires.	12	NA	500	1000pF	0.08uH	0.0E+00	0.0E+00	0.1	
						Cable Level Shields†	0	3	>80%						
						Bolometer signals from JFP (PMW 13-24)	24	3	DS 12-ax	500	1000pF	0.08uH	1.0E-09	5.0E-10	0.1
Type1		HSJFP J22	MDM 25 P	HSJFP P22	MDM 25S	Anti-cross talk ground wires.	12	NA	500	1000pF	0.08uH	0.0E+00	0.0E+00	0.1	
						Cable Level Shields†	0	3	>80%						
						Bolometer signals from JFP (PMW 25-36)	24	3	DS 12-ax	500	1000pF	0.08uH	1.0E-09	5.0E-10	0.1
						Anti-cross talk ground wires.	12	NA	500	1000pF	0.08uH	0.0E+00	0.0E+00	0.1	
C5	CVV 5	HSJFP J17	MDM 25 P	HSJFP P17	MDM 25S	Bolometer signals from JFP (PMW 49-60)	24	3	DS 12-ax	500	1000pF	0.08uH	1.0E-09	5.0E-10	0.1
						Anti-cross talk ground wires.	12	NA	500	1000pF	0.08uH	0.0E+00	0.0E+00	0.1	
						Cable Level Shields†	0	3	>80%						
						Bolometer signals from JFP (PMW 61-72)	24	3	DS 12-ax	500	1000pF	0.08uH	1.0E-09	5.0E-10	0.1
Type1		HSJFP J18	MDM 25 P	HSJFP P18	MDM 25S	Anti-cross talk ground wires.	12	NA	500	1000pF	0.08uH	0.0E+00	0.0E+00	0.1	
						Cable Level Shields†	0	3	>80%						
						Bolometer signals from JFP (PMW 73-84)	24	3	DS 12-ax	500	1000pF	0.08uH	1.0E-09	5.0E-10	0.1
						Anti-cross talk ground wires.	12	NA	500	1000pF	0.08uH	0.0E+00	0.0E+00	0.1	
C6	CVV 6	HSJFP J13	MDM 25 P	HSJFP P13	MDM 25S	Bolometer signals from JFP (PLW 1-12)	24	3	DS 12-ax	500	1000pF	0.08uH	1.0E-09	5.0E-10	0.1
						Anti-cross talk ground wires.	12	NA	500	1000pF	0.08uH	0.0E+00	0.0E+00	0.1	
						Cable Level Shields†	0	3	>80%						
						Bolometer signals from JFP (PLW 13-24)	24	3	DS 12-ax	500	1000pF	0.08uH	1.0E-09	5.0E-10	0.1
Type1		HSJFP J14	MDM 25 P	HSJFP P14	MDM 25S	Anti-cross talk ground wires.	12	NA	500	1000pF	0.08uH	0.0E+00	0.0E+00	0.1	
						Cable Level Shields†	0	3	>80%						
						Bolometer signals from JFP (PLW 25-36)	24	3	DS 12-ax	500	1000pF	0.08uH	1.0E-09	5.0E-10	0.1
						Anti-cross talk ground wires.	12	NA	500	1000pF	0.08uH	0.0E+00	0.0E+00	0.1	
C7	CVV 7	HSJFP J9	MDM 25 P	HSJFP P9	MDM 25S	Bolometer signals from JFP (PSW 1-12)	24	3	DS 12-ax	500	1000pF	0.08uH	1.0E-09	5.0E-10	0.1
						Anti-cross talk ground wires.	12	NA	500	1000pF	0.08uH	0.0E+00	0.0E+00	0.1	
						Cable Level Shields†	0	3	>80%						
						Bolometer signals from JFP (PSW 13-24)	24	3	DS 12-ax	500	1000pF	0.08uH	1.0E-09	5.0E-10	0.1
Type1		HSJFP J10	MDM 25 P	HSJFP P10	MDM 25S	Anti-cross talk ground wires.	12	NA	500	1000pF	0.08uH	0.0E+00	0.0E+00	0.1	
						Cable Level Shields†	0	3	>80%						
						Bolometer signals from JFP (PSW 25-36)	24	3	DS 12-ax	500	1000pF	0.08uH	1.0E-09	5.0E-10	0.1
						Anti-cross talk ground wires.	12	NA	500	1000pF	0.08uH	0.0E+00	0.0E+00	0.1	
C8	CVV 8	HSJFP J5	MDM 25 P	HSJFP P5	MDM 25S	Bolometer signals from JFP (PSW 49-60)	24	3	DS 12-ax	500	1000pF	0.08uH	1.0E-09	5.0E-10	0.1
						Anti-cross talk ground wires.	12	NA	500	1000pF	0.08uH	0.0E+00	0.0E+00	0.1	
						Cable Level Shields†	0	3	>80%						
						Bolometer signals from JFP (PSW 61-72)	24	3	DS 12-ax	500	1000pF	0.08uH	1.0E-09	5.0E-10	0.1
Type1		HSJFP J6	MDM 25 P	HSJFP P6	MDM 25S	Anti-cross talk ground wires.	12	NA	500	1000pF	0.08uH	0.0E+00	0.0E+00	0.1	
						Cable Level Shields†	0	3	>80%						
						Bolometer signals from JFP (PSW 73-84)	24	3	DS 12-ax	500	1000pF	0.08uH	1.0E-09	5.0E-10	0.1
						Anti-cross talk ground wires.	12	NA	500	1000pF	0.08uH	0.0E+00	0.0E+00	0.1	
C9	CVV 9	HSJFP J1	MDM 25 P	HSJFP P1	MDM 25S	Bolometer signals from JFP (PSW 85-96)	24	3	DS 12-ax	500	1000pF	0.08uH	1.0E-09	5.0E-10	0.1
						Anti-cross talk ground wires.	12	NA	500	1000pF	0.08uH	0.0E+00	0.0E+00	0.1	
						Cable Level Shields†	0	3	>80%						
						Bolometer signals from JFP (PSW 97-108)	24	3	DS 12-ax	500	1000pF	0.08uH	1.0E-09	5.0E-10	0.1
Type1		HSJFP J2	MDM 25 P	HSJFP P2	MDM 25S	Anti-cross talk ground wires.	12	NA	500	1000pF	0.08uH	0.0E+00	0.0E+00	0.1	
						Cable Level Shields†	0	3	>80%						
						Bolometer signals from JFP (PSW 109-120)	24	3	DS 12-ax	500	1000pF	0.08uH	1.0E-09	5.0E-10	0.1
						Anti-cross talk ground wires.	12	NA	500	1000pF	0.08uH	0.0E+00	0.0E+00	0.1	
C9	CVV 9	HSJFP J3	MDM 25 P	HSJFP P3	MDM 25S	Bolometer signals from JFP (PSW 121-132)	24	3	DS 12-ax	500	1000pF	0.08uH	1.0E-09	5.0E-10	0.1
						Anti-cross talk ground wires.	12	NA	500	1000pF	0.08uH	0.0E+00	0.0E+00	0.1	
						Cable Level Shields†	0	3	>80%						
						Bolometer signals from JFP (PSW 133-144)	24	3	DS 12-ax	500	1000pF	0.08uH	1.0E-09	5.0E-10	0.1
Type1		HSJFP J4	MDM 25 P	HSJFP P4	MDM 25S	Anti-cross talk ground wires.	12	NA	500	1000pF	0.08uH	0.0E+00	0.0E+00	0.1	
						Cable Level Shields†	0	3	>80%						



Name	128 Way Connector	FPU/JFS/JFP Connector Label	Unit Connector Type	Harness Connector Label	Harness Connector Type	Description	Number of Conductors excl. shields	Number of* inner Shields	Implementation	Max. Impedance R (W)	C(pF)	L(uH)	Max.Current in A. per Conductor	Av. Current in A per Conductor	Max. Volts						
C10 Aux-P	CVV 10	HSFPU J19	MDM 37 S	HSFPU P19	MDM 37P	Sorption Pump Heater	4	0	TQ	10			2.5E-02	6.3E-03							
						Evaporator HS Heater	4	0	TQ	50			1.5E-03	3.8E-04							
						Sorption Pump HS heater	4	0	TQ	50			1.5E-03	3.8E-04							
		HSFPU J21	MDM 37 S	HSFPU P21	MDM 37P	Various cooler thermistors	20	10	STQ	1000				1.0E-06	1.0E-06						
						Spectrometer Stimulus Thermistors	12	6	STQ	1000			1.0E-06	1.0E-06							
						Spectrometer Stimulus Heater 4%	4	0	TQ	30			9.0E-03	2.3E-03							
						Spectrometer Stimulus Heater 2%	4	0	TQ	30			7.0E-03	1.8E-03							
						FPU Thermometry	24	12	STQ	1000			1.0E-06	1.0E-06							
						300mK Thermal Control Heater	4	2	STQ	30			2.0E-03	5.0E-04							
C11 Drive-P	CVV 11	HSFPU J25	MDM 37 S	HSFPU P25	MDM 37P	BSM Chopper Sensors	3	1	STT	1000			1.0E-06	1.0E-06	0.4						
						BSM Chopper Sensors	2	1	STP	1000			1.0E-06	1.0E-06							
						BSM Jiggle Sensors	3	1	STT	1000			1.0E-06	1.0E-06							
						BSM Jiggle Sensors	2	1	STP	1000			1.0E-06	1.0E-06							
						BSM Temperature	4	2	STQ	1000			1.0E-06	1.0E-06							
						Photometer Stimulus Heater	4	2	STQ	10			7.0E-03	1.8E-03							
						BSM Launch latch sense	2	1	STP	1000			1.0E-03	0							
						BSM Launch latch solenoid	2	1	STP	10			3.5E-02	0							
						BSM Chop motor drive	4	2	STQ	10			4.0E-02	2.0E-02							
						BSM Jiggle motor drive	4	2	STQ	10			4.0E-02	5.0E-03							
						HSFPU J27	MDM 37 S	HSFPU P27	MDM 37P	SMEC Thermometry	8	4	STQ	1000				1.0E-06	1.0E-06		
										SMEC LVDT Primary	2	1	STP	5			5.0E-03	2.5E-03	5		
										SMEC LVDT Secondary	4	2	STP	50			5.0E-05	5.0E-02	15		
										SMEC Launch Latch	4	2	STP	5			4.0E-01	0.0E+00	15		
										SMEC Launch Latch (Rob.)	4	2	STP	5			4.0E-01	0.0E+00	15		
		SMEC Launch Latch Confirm	4	2	STP					5			1.0E-03	0.0E+00	15						
		HSFPU J29	MDM 37 S	HSFPU P29	MDM 37P					SMEC Drive Coil	2	1	STP	5				1.0E-01	8.0E-02	15	
										SMEC Drive (Rob.)	2	1	STP	5			1.0E-01	0.0E+00	15		
										SMEC Drive coil voltage sensor	2	1	STP	500			1.0E-05	1.0E-05	15		
						SMEC Position sensor supplies	2	1	STP	100			1.0E-03	1.0E-03	5						
						SMEC LED Power	2	1	STP	100			1.0E-03	8.0E-04	5						
						SMEC Position sensor photodiodes	6	3	STP	1000			2.0E-05	2.0E-05	5						
						SMEC Position sensor photodiodes FB	6	3	STP	1000			1.0E-05	1.0E-05	5						
						C12 Aux-R	CVV 12	HSFPU J20	MDM 37 S	HSFPU P20	MDM 37P	Sorption Pump Heater	4	0	TQ	10			2.5E-02	0	
												Heat switch heaters	8	0	TQ	50			1.5E-03	0	
		Various cooler thermistors	20	10	STQ							1000			1.0E-06	0					
		Spectrometer Stimulus Thermistors	12	6	STQ							1000			1.0E-06	0					
		Spectrometer Stimulus Heater 4%	4	0	TQ							30			9.0E-03	0					
		Spectrometer Stimulus Heater 2%	4	0	TQ							30			7.0E-03	0					
		HSFPU J24	MDM 37 S	HSFPU P24	MDM 37P			FPU Thermometry	24	12	STQ	1000				1.0E-06	0				
								300mK Thermal Control Heater	4	2	STQ	30			2.0E-03	0					
								C13 Drive-R	CVV13	HSFPU J26	MDM 37 S	HSFPU P26	MDM 37P	BSM Chopper Sensors	3	1	STT	1000			1.0E-06
		BSM Chopper Sensors	2	1	STP									1000			1.0E-06	0			
BSM Jiggle Sensors	3	1	STT	1000											1.0E-06	0					
BSM Jiggle Sensors	2	1	STP	1000											1.0E-06	0					
BSM Temperature	4	2	STQ	1000											1.0E-06	0					
Photometer Stimulus Heater	4	2	STQ	10											7.0E-03	0					
BSM Launch latch sense	2	1	STP	1000											1.0E-03	0					
BSM Launch latch solenoid	2	1	STP	10											3.5E-02	0					
BSM Chop motor drive	4	2	STQ	10											4.0E-02	0					
BSM Jiggle motor drive	4	2	STQ	10					4.0E-02					0							
HSFPU J28	MDM 37 S	HSFPU P28	MDM 37P	SMEC Thermometry	8	4	STQ	1000								1.0E-06	0				
				SMEC LVDT Primary	2	1	STP	5							5.0E-03	0	5				
				SMEC LVDT Secondary	4	2	STP	50							5.0E-05	0	15				
				SMEC Launch Latch	4	2	STP	5							4.0E-01	0	15				
				SMEC Launch Latch (Rob.)	4	2	STP	5							4.0E-01	0	15				
				SMEC Launch Latch Confirm	4	2	STP	5			1.0E-03	0	15								
				HSFPU J30	MDM 37 S	HSFPU P30	MDM 37P	SMEC Drive Coil	2	1	STP	5				1.0E-01	0	15			
								SMEC Drive (Rob.)	2	1	STP	5			1.0E-01	0	15				
								SMEC Drive coil voltage sensor	2	1	STP	500			1.0E-05	0	15				
SMEC Position sensor supplies	2	1	STP					100			1.0E-03	0	5								
SMEC LED Power	2	1	STP					100			1.0E-03	0	5								
SMEC Position sensor photodiodes	6	3	STP					1000			2.0E-05	0	5								
SMEC Position sensor photodiodes FB	6	3	STP					1000			1.0E-05	0	5								

* Inner shields are joined to 0V in the DRCU and are wired through these harnesses on pins, although they are often commoned/daisy chained.

†Cable Level Shields are joined to FPU/JFS/JFP backshells, are wired through the CVV wall connectors around their outer ring of pins, and correspond to the "D"s in the implementation cable types.

Name	128 Way Connector	DRCU Connector Label	DRCU Connector Type	Harness Connector Label	Harness Connector Type	Description	Number of Conductors excl. shlds	Number of inner Shields	Implementation	Max. Impedance	Max. Current in A.per Conductor	Av. Current in A per Conductor	Max. Volts										
										R (W)	C(pF)	L(uH)											
I1/S1 Type3	CVV 1	DCU J27	DCMA37 P	DCU P27	DCMA 37S	Bolometer signals from JFS (SLW 1-12)	24	12	STP	500	1500pF	0.08uH	1.00E-09	5.00E-10	0.1								
						SLW Ground	1	0	S	50	1500pF	0.08uH	0	0	0.1								
		DCU J28	DCMA37 P	DCU P28	DCMA 37 S	DCU P31	DCMA 37 P	Bolometer signals from JFS (SLW 13-24)	24	12	STP	500	1500pF	0.08uH	1.00E-09	5.00E-10	0.1						
								SLW Ground	1	0	S	50	1500pF	0.08uH	0	0	0.1						
								PTC Bias	2	2	STP	100	1500pF	0.08uH	3.20E-08	8.00E-09	10						
								PTC Ground wire	1	0	S	50	1500pF	0.08uH	0	0	10						
								PTC JFET Bias	2	2	STP	100	1500pF	0.08uH	5.00E-03	2.00E-04	10						
								SLW Bolometer Bias	4	4	STP	100	1500pF	0.08uH	9.60E-08	2.40E-08	10						
								SLW JFET Bias	4	4	STP	100	1500pF	0.08uH	2.50E-03	6.00E-04	10						
								SLW Ground wire	1	0	S	50	1500pF	0.08uH	0	0	10						
								SSW Bolometer Bias	4	4	STP	100	1500pF	0.08uH	1.20E-03	4.80E-08	10						
								SSW JFET Bias	4	4	STP	100	1500pF	0.08uH	5.00E-03	1.20E-03	10						
								SSW Ground Wire	1	0	S	50	1500pF	0.08uH	0	0	10						
								PTC JFET Heater	2	2	STP	200	1500pF	0.08uH	1.92E-03	4.81E-04	10						
								SLW JFET Heater	2	2	STP	200	1500pF	0.08uH	3.33E-03	8.33E-04	10						
								SSW JFET Heater	2	2	STP	200	1500pF	0.08uH	6.67E-03	1.67E-03	10						
								DCU J32	DCMA 37S	DCU P32	DCMA 37 P	DCU P32	DCMA 37 P	PTC Bias	2	2	STP	100	1500pF	0.08uH	3.20E-08	8.00E-09	10
														PTC Ground wire	1	0	S	50	1500pF	0.08uH	0	0	10
														PTC JFET Bias	2	2	STP	100	1500pF	0.08uH	5.00E-03	2.00E-04	10
														SLW Bolometer Bias	4	4	STP	100	1500pF	0.08uH	9.60E-08	2.40E-08	10
		SLW JFET Bias	4	4	STP	100	1500pF							0.08uH	2.50E-03	6.00E-04	10						
		SLW Ground wire	1	0	S	50	1500pF							0.08uH	0	0	10						
		SSW Bolometer Bias	4	4	STP	100	1500pF							0.08uH	1.20E-03	4.80E-08	10						
		SSW JFET Bias	4	4	STP	100	1500pF							0.08uH	5.00E-03	1.20E-03	10						
		SSW Ground Wire	1	0	S	50	1500pF							0.08uH	0	0	10						
		PTC JFET Heater	2	2	STP	200	1500pF							0.08uH	1.92E-03	4.81E-04	10						
		SLW JFET Heater	2	2	STP	200	1500pF	0.08uH	3.33E-03	8.33E-04	10												
		SSW JFET Heater	2	2	STP	200	1500pF	0.08uH	6.67E-03	1.67E-03	10												
Shield joined to all backshells						RF Overshield			>80%		0.01uH												
I2/S2	CVV 2	DCU J23	DCMA37 P	DCU P23	DCMA 37 S	Bolometer signals from JFS (SSW 1-12)	24	12	STP	500	1500pF	0.08uH	1.00E-09	5.00E-10	0.1								
		DCU J24	DCMA37 P	DCU P24	DCMA 37 S	Bolometer signals from JFS (SSW 13-24)	24	12	STP	500	1500pF	0.08uH	1.00E-09	5.00E-10	0.1								
						SSW Ground Wire	1	0	Single	50	1500pF	0.08uH	0.0	0.0	0.1								
		DCU J25	DCMA37 P	DCU P25	DCMA 37 S	Bolometer signals from JFS (SSW 25-36)	24	12	STP	500	1500pF	0.08uH	1.00E-09	5.00E-10	0.1								
		DCU J26	DCMA37 P	DCU P26	DCMA 37 S	Bolometer signals from JFS (SSW 37-42)	12	6	STP	500	1500pF	0.08uH	1.00E-09	5.00E-10	0.1								
Shield joined to all backshells						SSW Ground Wire	1	0	Single	50	1500pF	0.08uH	0.0	0.0	0.1								
Shield joined to all backshells						RF Overshield			>80%		0.01uH												
I3/S3 Type2	CVV 3	DCU J29	DDMA 78S	DCU P29	DDMA 78 P	PSW JFET Bias	12	12	STP	100	1500pF	0.08uH	5.00E-03	1.20E-03	10								
						PSW Ground	1	0	S	50	1500pF	0.08uH	0	0	10								
						PSW Bolometer Bias	6	6	STP	100	1500pF	0.08uH	3.84E-07	9.60E-08	10								
						PSW Heater	6	6	STP	200	1500pF	0.08uH	3.85E-03	9.62E-04	10								
						PMW JFET Bias	8	8	STP	100	1500pF	0.08uH	5.00E-03	1.20E-03	10								
						PMW Bolometer Bias	4	4	STP	100	1500pF	0.08uH	3.84E-07	9.60E-08	10								
						PMW Ground	1	0	S	50	1500pF	0.08uH	0	0	10								
						PMW JFET Heater	4	4	STP	200	1500pF	0.08uH	3.85E-03	9.62E-04	10								
						PLW JFET Heater	2	2	STP	200	1500pF	0.08uH	3.85E-03	9.62E-04	10								
						PLW JFET Bias	4	4	STP	100	1500pF	0.08uH	5.00E-03	1.20E-03	10								
						PLW Bolometer Bias	4	4	STP	100	1500pF	0.08uH	1.92E-07	4.80E-08	10								
						PLW Ground	1	0	S	50	1500pF	0.08uH	0	0	10								
						DCU J30	DDMA 78S	DCU P30	DDMA 78 P	DCU P30	DDMA 78 P	PSW JFET Bias	12	12	STP	100	1500pF	0.08uH	5.00E-03	1.20E-03	10		
												PSW Ground	1	0	S	50	1500pF	0.08uH	0.00E+00	0.00E+00	10		
												PSW Bolometer Bias	6	6	STP	100	1500pF	0.08uH	0.0	0.0	10		
		PSW Heater	6	6	STP							200	1500pF	0.08uH	3.85E-03	9.62E-04	10						
		PMW JFET Bias	8	8	STP							100	1500pF	0.08uH	5.00E-03	1.20E-03	10						
		PMW Bolometer Bias	4	4	STP							100	1500pF	0.08uH	3.84E-07	9.60E-08	10						
		PMW Ground	1	0	S							50	1500pF	0.08uH	0	0	10						
		PMW JFET Heater	4	4	STP	200	1500pF	0.08uH	3.85E-03	9.62E-04	10												
		PLW JFET Heater	2	2	STP	200	1500pF	0.08uH	3.85E-03	9.62E-04	10												
		PLW JFET Bias	4	4	STP	100	1500pF	0.08uH	5.00E-03	1.20E-03	10												
PLW Bolometer Bias	4	4	STP	100	1500pF	0.08uH	1.92E-07	4.80E-08	10														
PLW Ground	1	0	S	50	1500pF	0.08uH	0	0	10														
Shield joined to all backshells						RF Overshield			>80%		0.01uH												

Name	128 Way Connector	DRCU Connector Label	DRCU Connector Type	Harness Connector Label	Harness Connector Type	Description	Number of Conductors excl. shlds	Number of inner Shields	Implementation	Max. Impedance	Max. Current in A. per Conductor	Av. Current in A per Conductor	Max. Volts		
									R (W)	C(pF)	L(uH)				
I4/S4 Type1	CVV 4	DCU J20	DDMA 50 P	DCU P20	DDMA 50 S	16 ch. PMW (1-16) Ground Wire	32 1	16 0	STP S	500 50	1500pF 1500pF	0.08uH 0.08uH	1.00E-09 0	5E-10 0	0.1 0.1
		DCU J21	DDMA 50 P	DCU P21	DDMA 50 S	16 ch. PMW (17-32) Ground Wire	32 1	16 0	STP S	500 50	1500pF 1500pF	0.08uH 0.08uH	1.00E-09 0	5E-10 0	0.1 0.1
		DCU J22	DDMA 50 P	DCU P22	DDMA 50 S	16 ch. PMW (33-48) Ground Wire	32 1	16 0	STP S	500 50	1500pF 1500pF	0.08uH 0.08uH	1.00E-09 0	5E-10 0	0.1 0
		Shield joined to all backshells						RF Overshield			>80%		0.01uH		
I5/S5 Type1	CVV 5	DCU J17	DDMA 50 P	DCU P17	DDMA 50 S	16 ch. PMW (49-64) Ground Wire	32 1	16 0	STP S	500 50	1500pF 1500pF	0.08uH 0.08uH	1.00E-09 0	5E-10 0	0.1 0.1
		DCU J18	DDMA 50 P	DCU P18	DDMA 50 S	16 ch. PMW (65-80) Ground Wire	32 2	16 0	STP S	500 50	1500pF 1500pF	0.08uH 0.08uH	1.00E-09 0	5E-10 0	0.1 0.1
		DCU J19	DDMA 50 P	DCU P19	DDMA 50 S	16 ch. PMW (81-96) Ground Wire	32 1	16 0	STP S	500 50	1500pF 1500pF	0.08uH 0.08uH	1.00E-09 0	5E-10 0	0.1 0
		Shield joined to all backshells						RF Overshield			>80%		0.01uH		
I6/S6 Type1	CVV 6	DCU J14	DDMA 50 P	DCU P14	DDMA 50 S	16 ch. PLW (1-16) Ground Wire	32 1	16 0	STP S	500 50	1500pF 1500pF	0.08uH 0.08uH	1.00E-09 0	5E-10 0	0.1 0.1
		DCU J15	DDMA 50 P	DCU P15	DDMA 50 S	16 ch. PLW (17-32) Ground Wire	32 1	16 0	STP S	500 50	1500pF 1500pF	0.08uH 0.08uH	1.00E-09 0	5E-10 0	0.1 0.1
		DCU J16	DDMA 50 P	DCU P16	DDMA 50 S	16 ch. PLW (33-48) Ground Wire	32 1	16 0	STP S	500 50	1500pF 1500pF	0.08uH 0.08uH	1.00E-09 0	5E-10 0	0.1 0.1
		Shield joined to all backshells						RF Overshield			>80%		0.01uH		
I7/S7 Type1	CVV 7	DCU J11	DDMA 50 P	DCU P11	DDMA 50 S	16 ch. PSW (1-16) Ground Wire	32 1	16 0	STP S	500 50	1500pF 1500pF	0.08uH 0.08uH	1.00E-09 0	5E-10 0	0.1 0.1
		DCU J12	DDMA 50 P	DCU P12	DDMA 50 S	16 ch. PSW (17-32) Ground Wire	32 1	16 0	STP S	500 50	1500pF 1500pF	0.08uH 0.08uH	1.00E-09 0	5E-10 0	0.1 0.1
		DCU J13	DDMA 50 P	DCU P13	DDMA 50 S	16 ch. PSW (33-48) Ground Wire	32 1	16 0	STP S	500 50	1500pF 1500pF	0.08uH 0.08uH	1.00E-09 0	5E-10 0	0.1 0.1
		Shield joined to all backshells						RF Overshield			>80%		0.01uH		
I8/S8 Type1	CVV 8	DCU J8	DDMA 50 P	DCU P8	DDMA 50 S	16 ch. PSW (49-64) Ground Wire	32 1	16 0	STP S	500 50	1500pF 1500pF	0.08uH 0.08uH	1.00E-09 0	5E-10 0	0.1 0.1
		DCU J9	DDMA 50 P	DCU P9	DDMA 50 S	16 ch. PSW (65-80) Ground Wire	32 1	16 0	STP S	500 50	1500pF 1500pF	0.08uH 0.08uH	1.00E-09 0	5E-10 0	0.1 0.1
		DCU J10	DDMA 50 P	DCU P10	DDMA 50 S	16 ch. PSW (81-96) Ground Wire	32 1	16 0	STP S	500 50	1500pF 1500pF	0.08uH 0.08uH	1.00E-09 0	5E-10 0	0.1 0.1
		Shield joined to all backshells						RF Overshield			>80%		0.01uH		
I9/S9 Type1	CVV 9	DCU 5	DDMA 50 P	DCU P5	DDMA 50 S	16 ch. PMW (97-112) Ground Wire	32 1	16 0	STP S	500 50	1500pF 1500pF	0.08uH 0.08uH	1.00E-09 0	5E-10 0	0.1 0.1
		DCU J6	DDMA 50 P	DCU P6	DDMA 50 S	16 ch. PMW (113-128) Ground Wire	32 1	16 0	STP S	500 50	1500pF 1500pF	0.08uH 0.08uH	1.00E-09 0	5E-10 0	0.1 0.1
		DCU J7	DDMA 50 P	DCU P7	DDMA 50 S	16 ch. PMW (129-144) Ground Wire	32 1	16 0	STP S	500 50	1500pF 1500pF	0.08uH 0.08uH	1.00E-09 0	5E-10 0	0.1 0.1
		Shield joined to all backshells						RF Overshield			>80%		0.01uH		
I10/S10 Aux-P	CVV 10	FCU J11	DBMA 25 S	FCU P11	DBMA 25 P	Sorption Pump Heater	4	0	TQ	10			2.50E-02	6.25E-03	
						Evaporator HS Heater	4	0	TQ	50			1.50E-03	3.75E-04	
						Sorption Pump HS heater	4	0	TQ	50			1.50E-03	3.75E-04	
						300mK Thermal Control Heater	4	1	STQ	100			2.00E-03	5.00E-04	
						Spectrometer Stimulus Heater 4%	4	0	TQ	30			9.00E-03	2.25E-03	
						Spectrometer Stimulus Heater 2%	4	0	TQ	30			7.00E-03	1.75E-03	
FCUJ23	DDMA 50 S	FCU P23	DAMA 50 P	FPU Thermometry A	44	11	STQ	1000			1.00E-06	1.00E-06			
FCUJ25	DAMA 15 S	FCU P25	DAMA 15 P	FPU Thermometry B	12	3	STQ	1000			1.00E-06	1.00E-06			
Shield joined to all backshells						RF Overshield			>80%		0.01uH				



Name	128 Way Connector	DRCU Connector Label	DRCU Connector Type	Harness Connector Label	Harness Connector Type	Description	Number of Conductors excl. shlds	Number of inner Shields	Implementation	Max. Impedance C(pF) L(uH)	Max.Current in A.per Conductor	Av. Current in A per Conductor	Max. Volts		
I11/S11 Drive-P	CVV 11	FCU J21 FCU J19	DAMA 15 S DCMA 37 S	FCU P21 FCU P19	DAMA 15 P DCMA 37 P	FPU Thermometry C	12	3	STQ	1000	1.00E-06	0.000001	0.4		
						BSM Chop/Jiggle Sensors	4	2	STP	1000	1.00E-06	1.00E-06			
						BSM Chop/Jiggle Sensors	6	2	STT	1000	1.00E-06	1.00E-06			
						BSM Launch latch sense	2	1	STP	1000	0.001	0			
						BSM Launch latch solenoid	2	1	STP	10	0.035	0			
						BSM Chop motor drive	4	1	STQ	10	0.04	0.02			
		BSM Jiggle motor drive	4	1	STQ	10	0.04	0.005							
		FCU J29	DCMA 37 P	FCU P29	DCMA 37 S	SMEC LVDT Primary	2	1	STP	5	0.005	0.0025	0		
						SMEC LVDT Secondary	4	2	STP	5	0.00005	0.00005	0		
						SMEC Launch Latch1	4	2	STP	5	0.4	0			
						SMEC Launch Latch1 Confirm	2	1	STP	5	0.001	0			
						SMEC Launch Latch2	4	2	STP	5	0.4	0			
						SMEC Launch Latch2 Confirm	2	1	STP	5	0.001	0			
		FCU J17	DCMA 37 S	FCU P17	DCMA 37 P	SMEC Drive Coil	2	1	STP	5	0.1	0.08	0		
						SMEC Drive Coil (Rob.)	2	1	STP	5	0.1	0			
SMEC Drive coil voltage sensor	2					1	STP	500	0.00001	0					
SMEC Position sensor supplies	4					2	STP	100	0.001	0					
SMEC Position sensor photodiodes	6					3	STP	1000	0.00002	0					
SMEC Position sensor photodiodes FB	6					3	STP	1000	0.00001	0					
JB 11/35	Blanking cover	Mechanisms Launch Lock Confirm	6	3	STP	1000	0	0							
FCU J13	DEMA 9 S	FCU P13	DEMA 9P	P-Cal Heater	4	1	STQ	10	0.007	0.00175					
Shield joined to all backshells						RF Overshield		>80%		0.01uH					
I12/S12 Aux-R	CVV 12	FCU J12	DBMA 25 S	FCU P12	DBMA 25 P	Sorption Pump Heater	4	0	TQ	10	2.50E-02	0.00E+00			
						Heat switch heaters	8	0	TQ	50	1.50E-03	0.00E+00			
						300mK Thermal Control Heater	4	1	STQ	100	2.00E-03	0.00E+00			
						Spectrometer Stimulus Heater 4%	4	0	TQ	30	9.00E-03	0.00E+00			
						Spectrometer Stimulus Heater 2%	4	0	TQ	30	7.00E-03	0.00E+00			
						FCUJ24	DDMA 50 S	FCU P24	DDMA 50 P	FPU Thermometry A	44	11	STQ	1000	1.00E-06
		FCUJ26	DAMA 15 S	FCU P26	DAMA 15 P	FPU Thermometry B	12	3	STQ	1000	1.00E-06	0.00E+00			
		Shield joined to all backshells						RF Overshield		>80%		0.01uH			
		I13/S13 Drive-R	CVV 13	FCU J22 FCU J20	DAMA 15 S DCMA 37 S	FCU P22 FCU P20	DAMA 15 P DCMA 37 P	FPU Thermometry C	12	3	STQ	1000	1.00E-06	0	0.4
								BSM Chop/Jiggle Sensors	4	2	STP	1000	1.00E-06	0.00E+00	
BSM Chop/Jiggle Sensors	6							2	STT	1000	1.00E-06	0.00E+00			
BSM Launch latch sense	2							1	STP	1000	0.001	0			
BSM Launch latch solenoid	2							1	STP	10	0.035	0			
BSM Chop motor drive	4							1	STQ	10	0.04	0			
BSM Jiggle motor drive	4			1	STQ	10	0.04	0							
FCU J30	DCMA 37 P			FCU P30	DCMA 37 S	SMEC LVDT Primary	2	1	STP	5	0.005	0	0		
						SMEC LVDT Secondary	4	2	STP	5	0.00005	0	0		
						SMEC Launch Latch1	4	2	STP	5	0.4	0			
						SMEC Launch Latch1 Confirm	2	1	STP	5	0.001	0			
						SMEC Launch Latch2	4	2	STP	5	0.4	0			
						SMEC Launch Latch2 Confirm	2	1	STP	5	0.001	0			
FCU J18	DCMA 37 S			FCU P18	DCMA 37 P	SMEC Drive Coil	2	1	STP	5	0.1	0	0		
						SMEC Drive Coil (Rob.)	2	1	STP	5	0.1	0			
		SMEC Drive coil voltage sensor	2			1	STP	500	0.00001	0					
		SMEC Position sensor supplies	4			2	STP	100	0.001	0					
		SMEC Position sensor photodiodes	6			3	STP	1000	0.00002	0					
		SMEC Position sensor photodiodes FB	6			3	STP	1000	0.00001	0					
JD 11/35	Blanking cover	Mechanisms Launch Lock Confirm	6	3	STP	1000	0	0							
FCU J14	DEMA 9S	FCU P14	DEMA 9P	P-Cal Heater	4	2	STP	10	0.007	0					
Shield joined to all backshells						RF Overshield		>80%		0.01uH					

* Inner shields are joined to 0V in the DRCU and are wired through these harnesses on pins, although they are often commoned/daisy chained.

SPIRE IIDB 3.2 - ANNEX

Annex 4

Description of the Operation of the ³He Sorption Cooler

Description of the Operation of the ³He Sorption Cooler

The ³He cooler is produced for Spire and PACS by SBT/CEA, Grenoble, who own the intellectual information in this annex. The cooler is specified in SBT documents HSO-SBT-SP-001-3-3 and HSO-SBT-TNS-2; its interfaces internal to Spire are controlled via HSO-SBT-ICD-012-1-3.

The cooler’s internal thermal configuration is as follows:

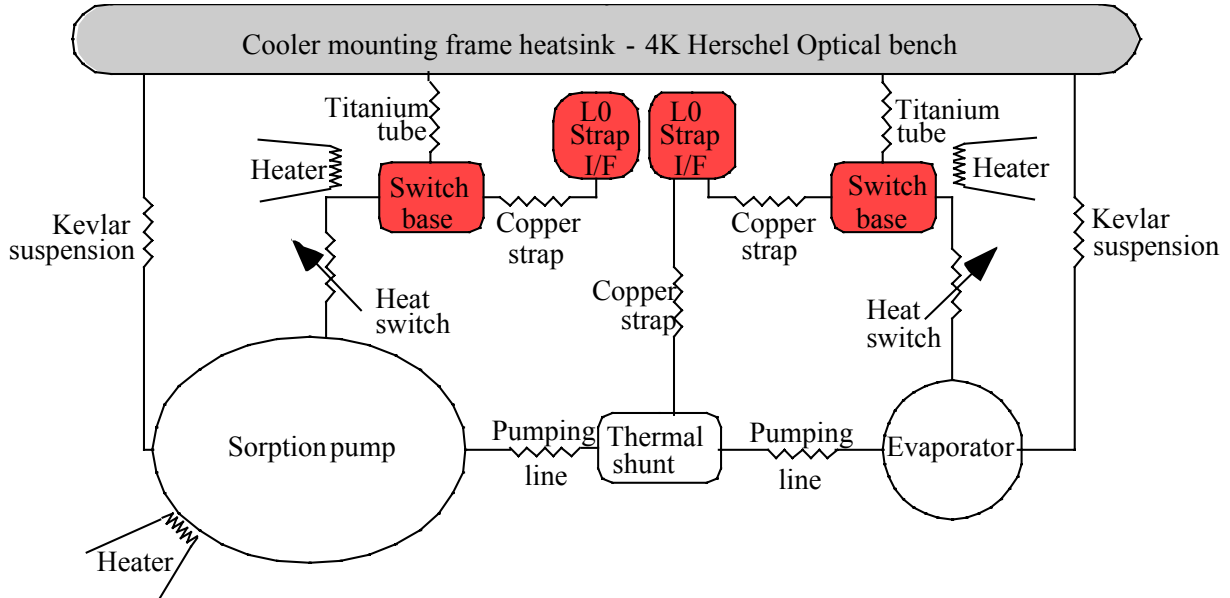

Figure 1: SPIRE Sorption cooler

The cooler is hermetically closed and does not have a lifetime limited by its cryogen boil-off. However it cannot cool continuously but rather it needs to be re-generated regularly. This regeneration energy cycle is a small but significant contribution to the total dissipation within the Herschel cryostat.

When operational, Spire runs a 48 hour ³He cooler cycle, 46 hours with Spire’s detectors cooled to “300mK” and 2 hours recycling. This fits in with Herschel ground commanding periods.

When at “300mK”, the temperature at the cooler’s evaporator is to a very good approximation a single valued function of gross applied load on its evaporator, i.e. available/net cooling power PLUS the cooler’s internal parasitics. The cooling is simply due to the physical process of evaporation along the cooler’s “pumping line” geometry(see above figure). The function is shown below in figure 2) which is derived by offsetting curves of tip temperature v. load that have been measured at different L1 and hence parasitics. A puzzling factor is that the TRP 4 litre contract showed this characteristic to be independent of attitude but under test the 6 litre units shows some dependency on attitude.

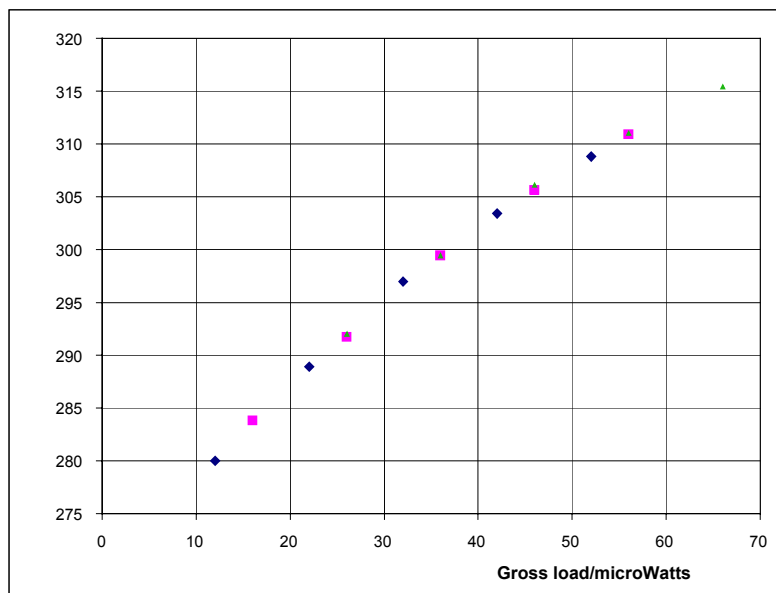

Figure 2: Evaporator temperature vs total load

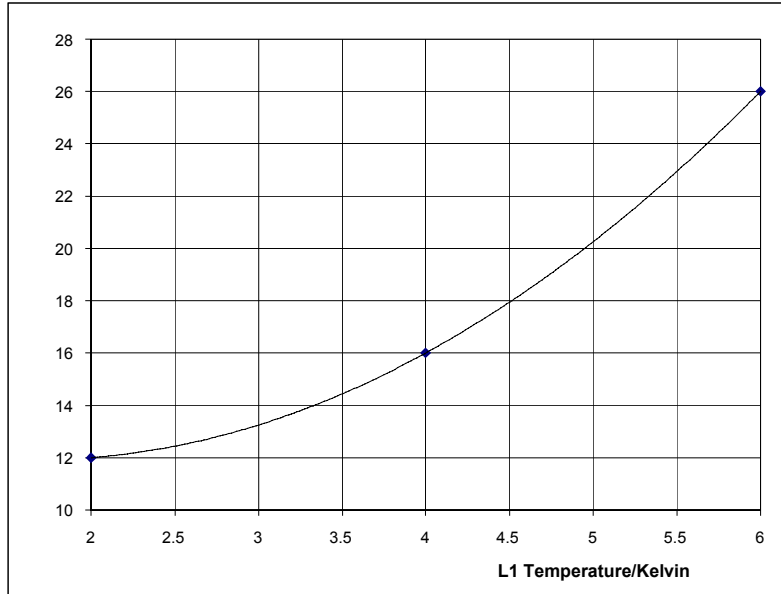

Figure 3: Cooler parasitic loads vs level 1 temperature

The baseline parasitic of 280mK shown in figure 2 of 12microwatts for L1 = 2K is indirectly derived, but the data plotted in figure 3 are the shifts needed to superimpose the curves at different L1 in 2a, They suggest a stronger dependence of cooler parasitics on L1 temperature than is often assumed.

Contributions to the cooler’s internal evaporator parasitics are heat-switch off-state leakage to L0, tube conduction to the thermal shunt, wiring conduction, and Kevlar suspension leakage to L1, presuming the lack of unwanted effects inside the cooler. For details see Annex 3.

In the 46hr. operating/observing mode only the sorption pump sieve heat-switch heater is on. The following confirms a sieve switch-over temperature of 12-13K.

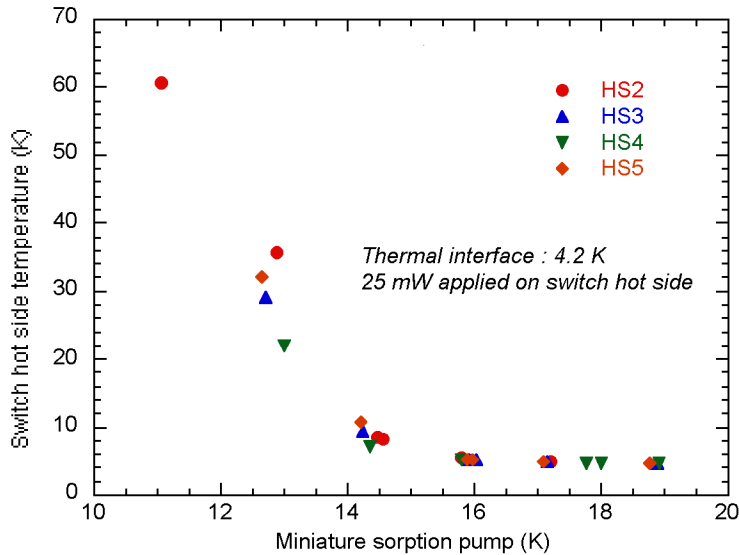

Figure 4: Heat switch "switching temperature" (vs switch pump temperature)

The power needed to raise the switch’s sieve to ~14K is ~200W. To have margin, ~400W has been demonstrated to run the pump switch and to speed up the switch-over phase the sieve is heated at 800W for an initial limited time.

As helium evaporates, heat is pumped. There is an amplification factor between the heat load at the evaporator and the resulting adsorption heat load on the pump which is sunk down the turned-on pump switch and its strap. The following curves are from an experiment to measure this.

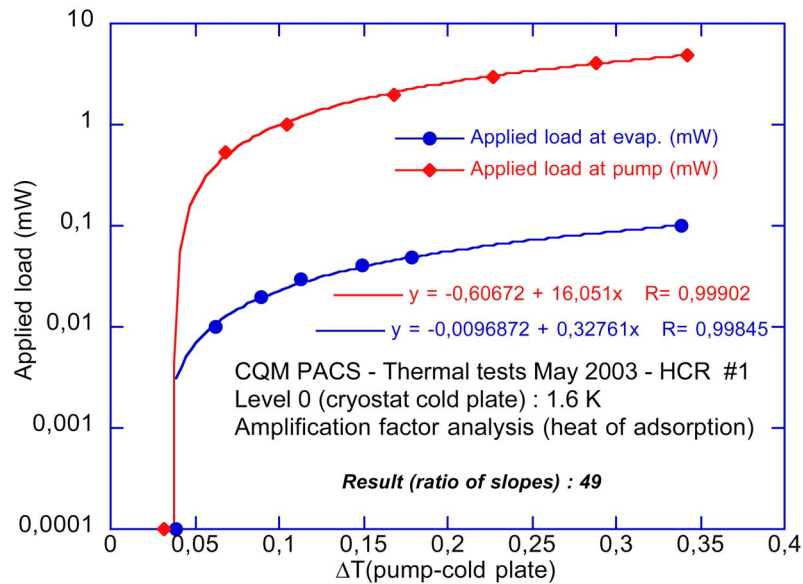

Figure 5 : Measurement of adsorption heat on pump vs heat applied on evaporator

A ratio between these heat loads of 46-49 is typical for ^3He coolers, and such a test result shows that the cooler is pumping properly according to the expected thermodynamics.

In practise the whole system must be able to cope with the 2 hour recycling heat mode. This is in many respects is more demanding than the 46hour hold-time.

During the first phase of recycling, i.e. condensation, the evaporator heat-switch is closed and the pump's switch opened. The evaporator strap needs extremely low thermal impedance and 800W heat-switch sieve power is baselined. The cooler's sorption pump is heated to 40-45K and a lower power is then used to keep it hot. Condensation occurs in the evaporator. Almost all the cooler's ^3He charge needs to be condensed so Spire can meet the hold-time for its subsequent 46 hours at 300mK. The temperature of the evaporator itself at the end of condensation is critical. This is a parameter internal to Spire, even being internal to one of its subsystems, and it needs to be $<2\text{K}$ for the last few minutes of this phase. We may need to apply 1mW to the evaporator's heat-switch sieve the end of the condensation phase to help to achieve this $<2\text{K}$.

During this condensation phase the shunt has to extract nearly all the heat from the hot gas travelling from the pump to the evaporator; it should typically stay below 6K. More than $>80\%$ of the enthalpy of the hot gas should be thus removed. throughout the condensation phase. The overall shunt strap actually needs a tuned conductance because during the condensation phase its temperature needs to go and stay above T_{evap} to avoid ^3He condensing on it instead of in the evaporator.

At the end of the condensation phase there is a cooling phase when and the cooler heat switches are swapped over to their normal (operating) positions: the pump switch is on and the evaporator's off. Timings for this have to be optimised by test. This cooler requires that its pump and evaporator have separate straps back to Herschell's main 4Hell because otherwise the heat-pulse that occurs at this switch-over could heat the evaporator and waste much of the available ^3He liquid charge.

Recycling of a flight type 6 litre coolers is shown below, but with a warning that it has been obtained at unit level with 200mW/K conductances for both the straps from the cooler heatswitch interfaces (which are not Spire/Herschel Interfaces) to the 4Hell (at $<1.7\text{K}$). When later results with flight type conductances are available, these results will need updating. For instance when the cooler is accommodated inside Spire the 350J pump power spike is likely to peak at only $\sim 500\text{mW}$ and of course therefore to last longer.

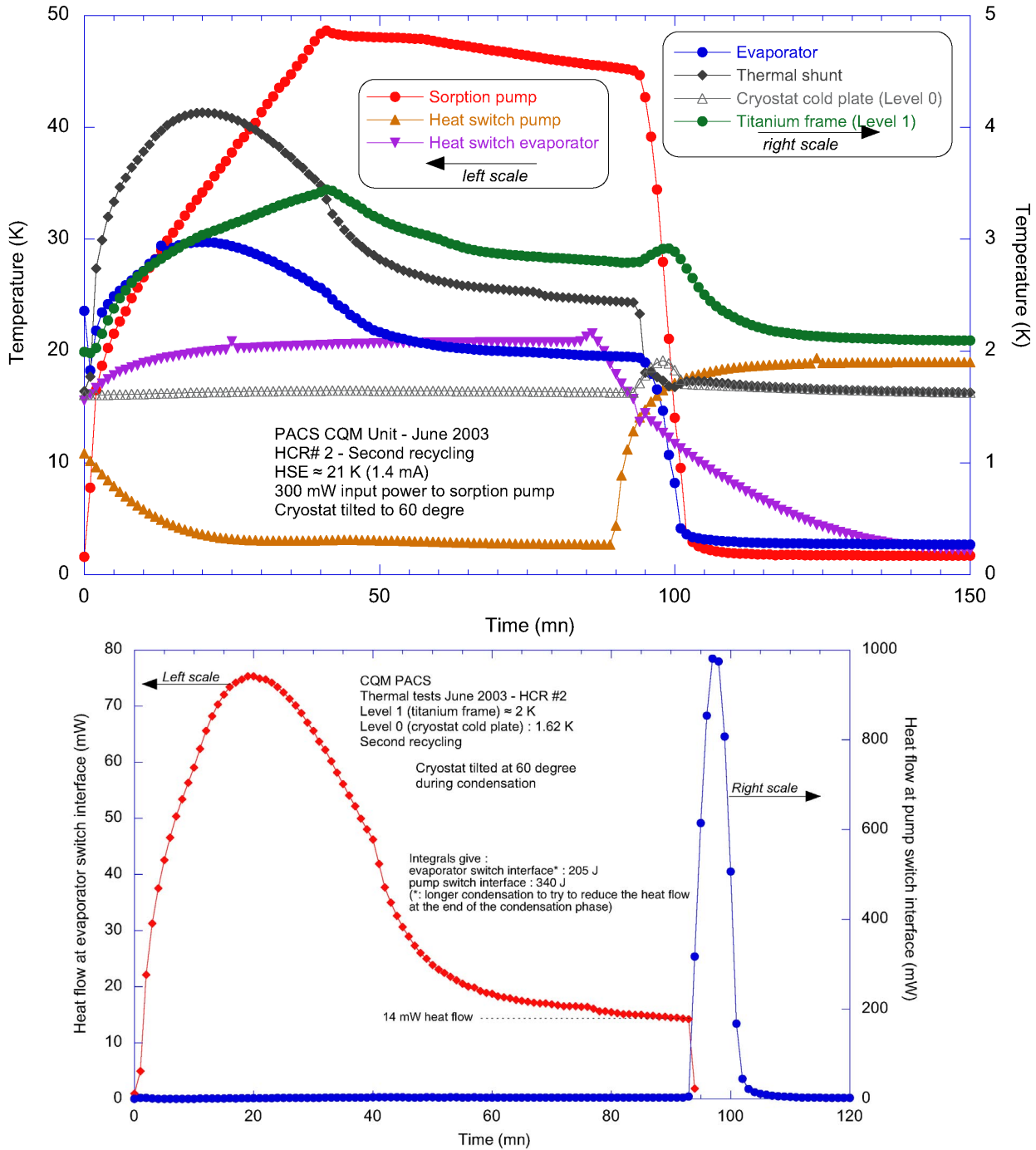

Figure 6: Cooler Recycling: Characteristics above and estimated heat-flows below

We see that during test, and probably in flight also, the cooler’s titanium frame alters temperature during recycling. This is even with the cooler chassis fixed all along one side (PACS style) to the L1 test plate.

Generally the faster the whole regeneration process the better, both in terms of the minimising the total single recycle energy and in terms of the fraction of time available for science. By searching for efficient operation, in Spire we have set the initial pump heater power to 300mW. If the heat shunt and evaporator strap could take the load as a high flow-rate of warm 3He leaves the pump, we could heat the pump with some 600mW to 40K very quickly, keep it there for just a few minutes, turn off and let everything cool down again, which would achieve a very energy efficient regeneration. In practise, strap impedance both limits the initial power that can be applied and causes us to need to wait an appreciable time before the evaporator comes back down to <2K, the point at which “cool down” can be commenced.

The time taken for the 6 litre flight cooler’s sorption pump to be heated up to ~40-45K is expected to be ~30minutes. SBT/CEA have put considerable effort into developing the heat straps inside the cooler to cut down the wait time for evaporator itself to get back down to <2K at the end of the condensation phase.

The shunt and the evaporator share an L0 strap, the latter via a heat-switch. The energy to be transported during recycling from the evaporator itself is expected to be 50 Joules with the profile shown, peaking at a power of

45mW. However the total energy through this strap per cycle is ~205 Joules when the shunt's contribution is also added in, peaking at 75mW. Although evaporator power may drop to <2mW at the end of the condensation phase, there is still ~13mW from the shunt added into the strap to give a total power along it of ~15mW.

Achieving the 46 hours lifetime requires a minimised total load on the 300mK evaporator, and also on the cooler achieving its full 6 litre latent heat energy rating. Spire should only place an external load on the cooler such that the total load remains below ~29Watts

Not achieving an evaporator temperature of <2K at the end of the condensation phase would cause an unacceptable reduction in the amount of condensed helium in the evaporator available for next operation phase. This is computed to be:

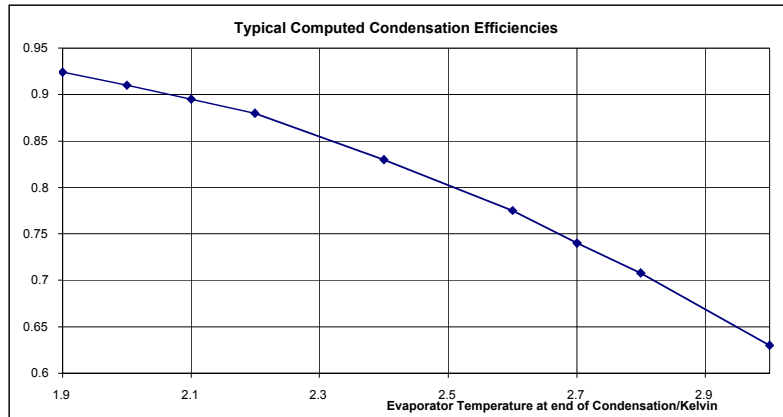

Figure 7 : Estimated Condensation efficiency (% ³He liquefied) vs evaporator temperature

A fraction of the 3He charge is expended cooling both itself and the evaporator/detectors down to 300mK, which is taken as the end of recycling. This leaves an amount of 3He available to keep the Spire 300mK section cooled for the next 46 hrs. The evaporator temperature at the end of the previous phase is again critical to minimising He usage for this pre-cooling process, and <2K is required.

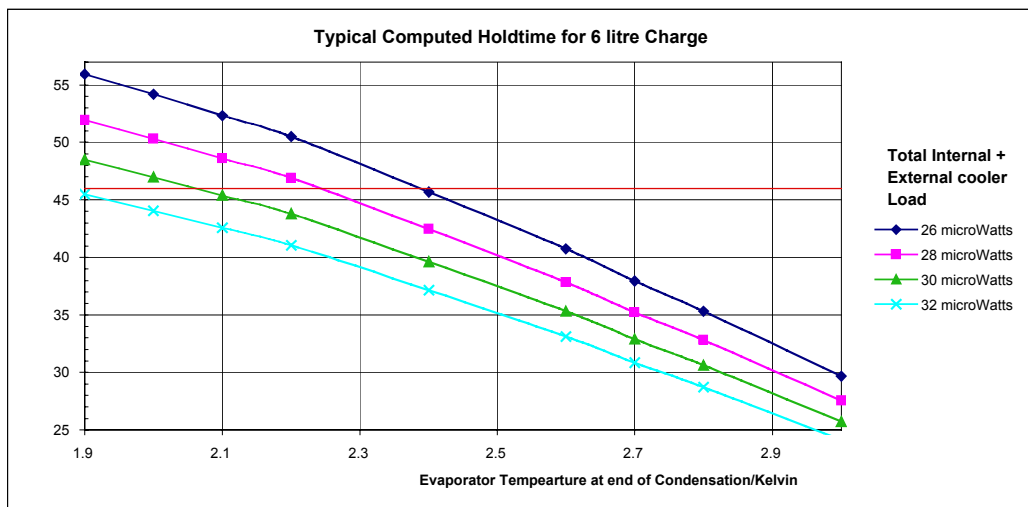

Figure 8 : Cooler hold time ve evaporator temperature at end of condensation, and average total load on evaporator.

Figure 8 is the same as one from the IHDR but with the above condensation efficiencies also included.

These curves are an approximation in that they ignore the small extra demands on the cooler from all loads during the 2K to 300mK cooldown and the heat capacity during this period of all 300mK components besides that of the helium itself. However, these effects are small and the approximation is good.

Note:

There is one cooler variation still under consideration by **Spire**. The requirement that the evaporator itself be <2K at the end of the condensation phase [typically 1.85K at the cooler's heat-switch interface inside the instrument] is sufficiently challenging to achieve that we were considering putting the shunt on the pump's strap rather than on the evaporator's, see thermal overview drawing at the start of this section. This would avoid ~15mWatts from the shunt travelling down the evaporator strap at this stage in the recycling, thus avoiding its contribution to the

temperature drop along the strap. Caveat: it's not clear yet if this alteration has other significant disadvantageous side-effects, and the project has seriously run out of time to put such a change into the programme.

SPIRE IIDB issue 3.2 - ANNEX

Annex 5

SPIRE HDD 1.1 Deltas

SPIRE-RAL-NOT-001819 , Issue 3 , 23/10/03



SPIRE
HDD 1.1 Deltas

Doc #: SPIRE-RAL-NOT-001819
Issue: 3.0
Date: 23/10/03
Page 1 of 29

Issue 2.0 of this document includes comments on the EADS 2.6 Harness Database.

Digitally signed by Douglas Griffin
DN: cn=Douglas Griffin, o=RAL-SSTD, ou=SET, c=GB
Date: 2003.09.25 20:53:12 Z

Signature Not Verified

Issue 3.0 of this document incorporates the decision reached on the polarity of the pins on the 128-way for the "SMEC Position Sensor Power Sply"

Digitally signed by Douglas Griffin
DN: cn=Douglas Griffin, o=RAL-SSTD, ou=SET, c=GB
Date: 2003.10.29 15:33:07 Z

Signature Not Verified

Subject: **HDD 1.1 DELTAS**

The sheets that follow show the pinout & wire name changes compared to the Spire Harness Definition Document version 1.1 that are needed to build the PFM harness. They will be issued within HDD version 1.2.

PREPARED BY:

D.K. GRIFFIN

Digitally signed by Douglas Griffin
DN: cn=Douglas Griffin, o=RAL-SSTD, ou=SET, c=GB
Date: 2003.09.24 11:36:45 Z

Signature Not Verified

Date:

APPROVED BY:

J. DELDERFIELD.....



John Delderfield

2003.09.23
14:14:32 +
01'00'

Number	Pages and section from HDD 1.1	Description of correction	Notes	Comparison with EICD, Issue 2.6
1	Page 58-60, S4	Corrected assignment of Channel numbers in column 2 to pixels column 3	No hardware implications. Nomenclature only	
2		Pixels PMW-F8, PMW-E9 corrected 128-way pin assignments		Compliant (See Page 22, 23 and 24 of this doc)
3	Pages 67-69, S6	Corrected sequence of Pixel names.	No hardware implications. Nomenclature only	
4	Page 172, C11	Polarity error on 128-way "SMEC Position Sensor Power Supply and Return"	<u>Swapped 4 and 11. After telecon clarification - Pin 11 on the 128-way is to be positive and Pin 4 is to be negative as per Astrium EICD Issue 2.6</u>	The polarity of the signals on the 12-way connectors in the HDD 1.2 is opposite to that adopted in EADS 2.6. This is not a S/C problem as the interfaces to the FCU and the FPU are correct in the EADS doc - See pages 25, 26, 27 and 28 of this document
5	Page 118, 120, C1	"Channel 1 gnd shld" should be Channel 14 gnd shld" in column 2, row 2, page 119		
6	Page 119, C1	"SLW_JFETV_A2_shld" should go to pin 26 not 6	Pins 26 and 6 are both on a busbar and therefore this is an academic correction	Compliant- See page 29 of this document.
7	Page 131, C3	Reference to D2 and D4 removed. Changed to B2 / B4		EADS implementation not as SPIRE intended – however the EADS design is compliant with SPIRE requirements
8	Page 132, C3	Reference to D2 changed to B2		idem
9	Page 134, C3	References to D4 changed to B4		Idem
10	Page 146, C6	"Channel 1 gnd shld" should be Channel 14 gnd shld" in column 2, row 24, page 146		
11	Page 151, C8	Colum headers should be P05, P06, P07 and P08 not J05, J06, J07 and J08		
12	Page 152, C8	"Channel 1 gnd shld" should be Channel 14 gnd shld" in column 2, row 19, page 152		
13	Page 155, C9	"Channel 1 gnd shld" should be Channel 14 gnd shld" in column 2, row 27, page 155		
14	Page 95	Second table should be labelled with FCU P29 not FCU P27	This page was in Issue 1.0 of this doc, but no mention of it was made in this table	

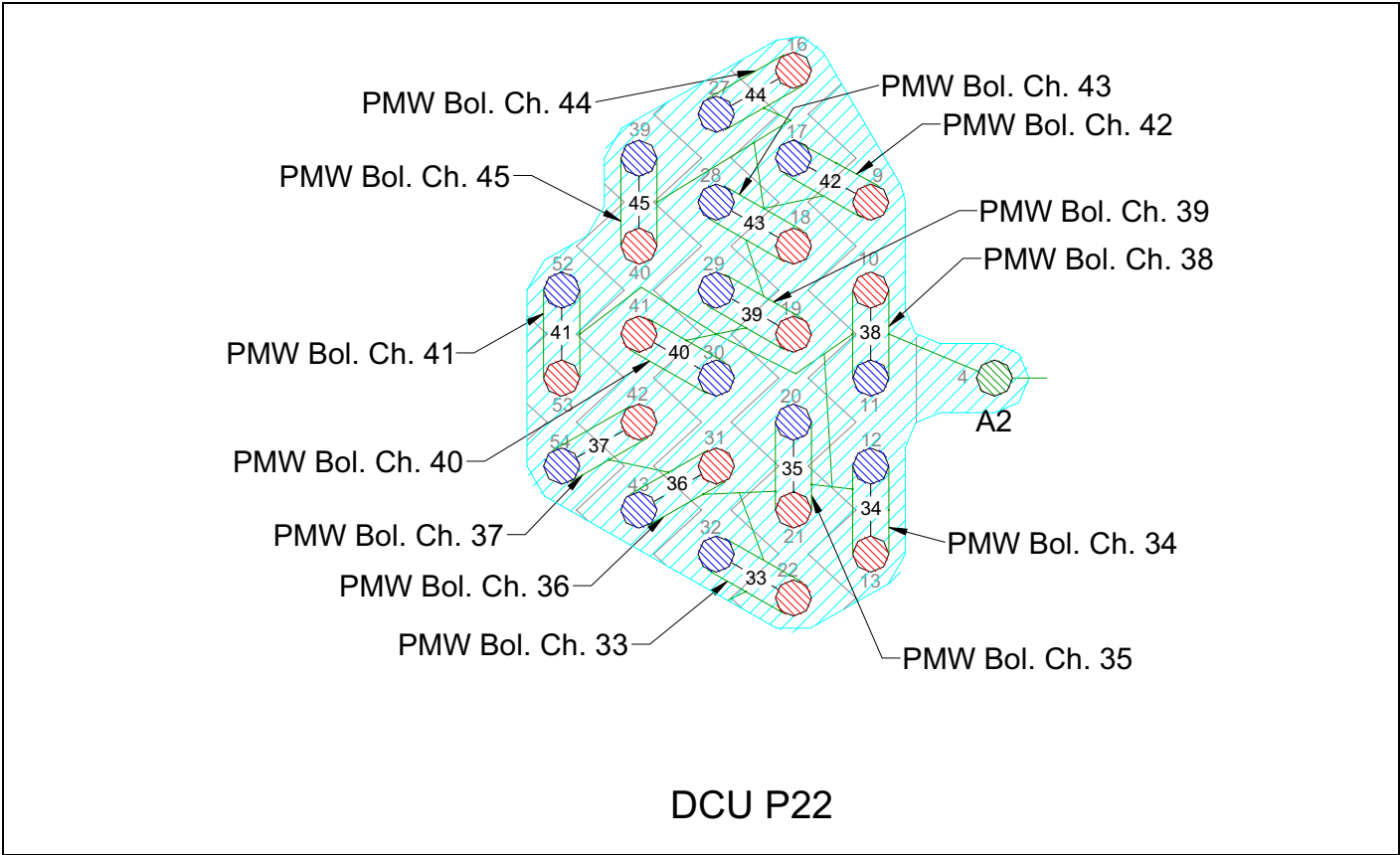

Contact Details

Notes:

- The shields of the STP cables carrying, the ground wires (GND_WIRE) and Pins 36(A1), 4(A2), 128(A3) and 47(A4) of the 128-way connector are all joined to form a ground reference plane. Pin numbers for connector PE assume the use of a DEMA 9 connector.
- Refer to Annex 7 - PTC Cryo-harnessing that indicates graphically the means by which these signals are wired.

Cable ID		Pixel	128 Way #4	DCU P20	DCU P21	DCU P22	PE J22 Link (I/F S2/S4)
	Signal Ground		47 (A4)				
S4-STP-A1	Channel 1+	PMW-F10	26	1			
	Channel 1-		37	18			
	Channel 1 GND		36 (A1)	34			
S4-STP-A2	Channel 2+	PMW-E11	38	2			
	Channel 2-		49	19			
	Channel 2 GND		36 (A1)	35			
S4-STP-A3	Channel 3+	PMW-G11	48	3			
	Channel 3-		60	20			
	Channel 3 GND		36 (A1)	36			
S4-STP-A4	Channel 4+	PMW-F11	59	4			
	Channel 4-		71	21			
	Channel 4 GND		36 (A1)	37			
S4-STP-B1	Channel 5+	PMW-E12	50	5			
	Channel 5-		61	22			
	Channel 5 GND		36 (A1)	38			
S4-STP-B2	Channel 6+	PMW-G12	62	6			
	Channel 6-		51	23			
	Channel 6 GND		36 (A1)	39			
S4-STP-B3	Channel 7+	PMW-F12	63	7			
	Channel 7-		75	24			
	Channel 7 GND		36 (A1)	40			
S4-STP-B4	Channel 8+	PMW-G13	74	8			
	Channel 8-		73	25			



SPIRE HARNESS DEFINITION DOCUMENT (deltas)

Doc: SPIRE-RAL-PRJ-001819

Cable ID		Pixel	128 Way #4	DCU P20	DCU P21	DCU P22	PE J22 Link (I/F S2/S4)
	Channel 8 GND		36 (A1)	41			
	Signal Ground		36 (A1)	9			
S4-STP-C1	Channel 9+	PMW-DK2	83	26			
	Channel 9-		72	10			
	Channel 9 GND		36 (A1)	43			
S4-STP-D1	Channel 13+	PMW-E7	86	27			
	Channel 13-		87	11			
	Channel 13 GND		36 (A1)	44			
S4-STP-D2	Channel 14+	PMW-D7	97	28			
	Channel 14-		98	12			
	Channel 14 GND		36 (A1)	45			
S4-STP-D3	Channel 15+	PMW-F7	108	29			
	Channel 15-		109	13			
	Channel 15 GND		36 (A1)	46			
S4-STP-D4	Channel 16+	PMW-E8	116	30			
	Channel 16-		117	14			
	Channel 16 GND		36 (A1)	47			
S4-STP-E1	Channel 17+	PMW-G8	55	31			
	Channel 17-		66	15			
	Channel 17 GND		128 (A3)	48			
S4-STP-E2	Channel 18+	PMW-F8	67	32			
	Channel 18-		78	16			
	Channel 18 GND		128 (A3)	49			
S4-STP-E3	Channel 19+	PMW-E9	76	33			
	Channel 19-		77	17			
	Channel 19 GND		128 (A3)	50			
S4-STP-E4	Channel 20+	PMW-G9	88		1		
	Channel 20-		89		18		
	Channel 20 GND		128 (A3)		34		
S4-STP-F1	Channel 21+	PMW-D9	99		2		
	Channel 21-		100		19		
	Channel 21 GND		128 (A3)		35		
S4-STP-F2	Channel 22+	PMW-F9	110		3		
	Channel 22-		111		20		
	Channel 22 GND		128 (A3)		36		
S4-STP-F3	Channel 23+	PMW-E10	118		4		
	Channel 23-		119		21		
	Channel 23 GND		128 (A3)		37		
S4-STP-F4	Channel 24+	PMW-G10	112		5		
	Channel 24-		120		22		
	Channel 24 GND		128 (A3)		38		
S4-STP-G1	Channel 25+	PMW-C4	90		6		
	Channel 25		79		23		
	Channel 25 GND		128 (A3)		39		
S4-STP-G2	Channel 26+	PMW-B3	102		7		
	Channel 26-		101		24		
	Channel 26 GND		128 (A3)		40		
S4-STP-G3	Channel 27+	PMW-C3	92		8		
	Channel 27-		91		25		
	Channel 27 GND		128 (A3)		41		
	Signal Ground		128 (A3)		9		
S4-STP-G4	Channel 28+	PMW-B2	103		26		
	Channel 28-		113		10		
	Channel 28 GND		128 (A3)		43		
S4-STP-H1	Channel 29+	PMW-D2	58		27		
	Channel 29-		46		11		
	Channel 29 GND		128 (A3)		44		
S4-STP-H2	Channel 30+	PMW-A3	68		28		
	Channel 30-		57		12		
	Channel 30 GND		128 (A3)		45		
S4-STP-H3	Channel 31+	PMW-A2	69		29		
	Channel 31-		80		13		
	Channel 31 GND		128 (A3)		46		
S4-STP-H4	Channel 32+	PMW-C2	70		30		
	Channel 32-		81		14		
	Channel 32 GND		128 (A3)		47		
S4-STP-I1	Channel 33+	PMW-B1	23		31		
	Channel 33-		34		15		
	Channel 33 GND		4 (A2)		48		



SPIRE HARNESS DEFINITION DOCUMENT (deltas)

Doc: SPIRE-RAL-PRJ-001819

Cable ID		Pixel	128 Way #4	DCU P20	DCU P21	DCU P22	PE J22 Link (I/F S2/S4)
S4-STP-I2	Channel 34+	PMW-A1	33		32		
	Channel 34-		45		16		
	Channel 34 GND		4 (A2)		49		
S4-STP-I3	Channel 35+	PMW-DK1	44		33		
	Channel 35-		56		17		
	Channel 35 GND		4 (A2)		50		
S4-STP-I4	Channel 36+	PMW-C1	22			1	
	Channel 36-		32			18	
	Channel 36 GND		4 (A2)			34	
S4-STP-J1	Channel 37+	PMW-A7	13			2	
	Channel 37-		12			19	
	Channel 37 GND		4 (A2)			35	
S4-STP-J2	Channel 38+	PMW-A6	21			3	
	Channel 38-		20			20	
	Channel 38 GND		4 (A2)			36	
S4-STP-J3	Channel 39+	PMW-B6	31			4	
	Channel 39-		43			21	
	Channel 39 GND		4 (A2)			37	
S4-STP-J4	Channel 40+	PMW-C7	42			5	
	Channel 40-		54			22	
	Channel 40 GND		4 (A2)			38	
S4-STP-K1	Channel 41+	PMW-A5	10			6	
	Channel 41-		11			23	
	Channel 41 GND		4 (A2)			39	
S4-STP-K2	Channel 42+	PMW-B5	19			7	
	Channel 42-		29			24	
	Channel 42 GND		4 (A2)			40	
S4-STP-K3	Channel 43+	PMW-C6	41			8	
	Channel 43-		30			25	
	Channel 43 GND		4 (A2)			41	
	Signal Ground		4 (A2)			9	
S4-STP-K4	Channel 44+	PMW-D6	53			26	
	Channel 44-		52			10	
	Channel 44 GND		4 (A2)			43	
S4-STP-L1	Channel 45+	PMW-B4	9			27	
	Channel 45-		17			11	
	Channel 45 GND		4 (A2)			44	
S4-STP-L2	Channel 46+	PMW-C5	18			28	
	Channel 46-		28			12	
	Channel 46 GND		4 (A2)			45	
S4-STP-L3	Channel 47+	PMW-D4	16			29	
	Channel 47-		27			13	
	Channel 47 GND		4 (A2)			46	
S4-STP-L4	Channel 48+	PMW-A4	40			30	
	Channel 48-		39			14	
	Channel 48 GND		4 (A2)			47	
S4-STP-PTC1	PTC Channel 1 +	PTC-1	N.C.			31	1
	PTC Channel 1 -		N.C.			15	6
	PTC Channel 1gnd		N.C.			48	2 (A)
S4-STP-PTC2	PTC Channel 2 +	PTC-2	N.C.			32	3
	PTC Channel 2 -		N.C.			16	7
	PTC Channel 2gnd		N.C.			49	8(A)
S4-STP-PTC3	PTC Channel 3 +	PTC-3	N.C.			33	4
	PTC Channel 3 -		N.C.			17	5
	PTC Channel 3gnd		N.C.			50	8(A)
			EMC Backshell	EMC Backshell	EMC Backshell	EMC Backshell	EMC Backshell

FPU Faraday Shield Link Pins												
1	2	3	5	6	7	8	14	15	24	25	35	82
93	94	104	105	114	115	121	122	123	124	125	126	127

4.2.6 S6 SVM-CB 6 – DRCU (Type 1) PLW

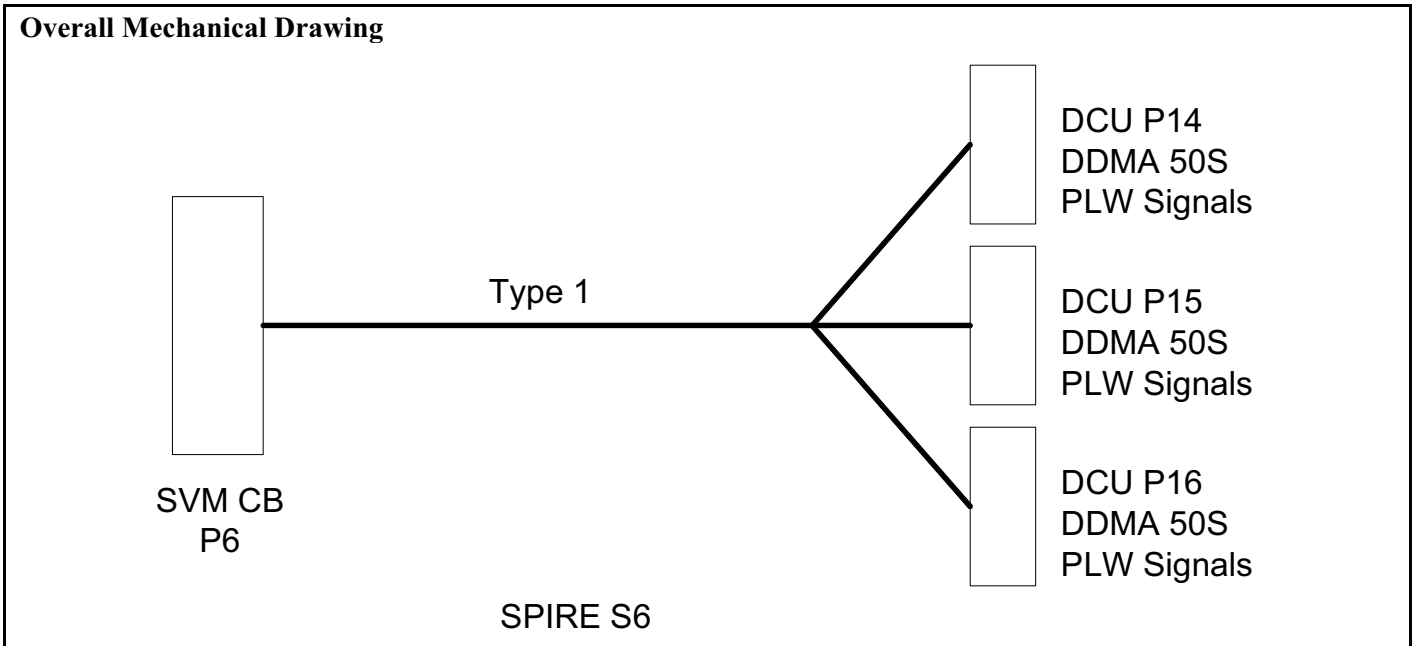

Connector/Backshell Details

DDMA50S+Glenair557-B-357-M-5- TBD toDCUJ14 DCU-JFP
 DDMA50S+Glenair557-E-359-M-5- TBD toDCUJ15 DCU-JFP
 DDMA50S+Glenair557-B-357-M-5- TBD toDCUJ16 DCU-JFP

Harness Layup

As S5 except
 Tail A = HSDCU P14
 Tail B = HSDCU P15
 Tail C = HSDCU P16

Contact details

	Name	Pixel	128Way #6	DCU J14	DCU J15	DCU J16
	Ground Pin		47 (A4)			
S6-STP-A1	Channel 1 +	PLW-R1	26	1		
	Channel 1 -		37	18		
	Channel 1gnd shld		36 (A1)	34		
S6-STP-A2	Channel 2 +	PLW-A8	38	2		
	Channel 2 -		49	19		
	Channel 2gnd shld		36 (A1)	35		
S6-STP-A3	Channel 3 +	PLW-A7	48	3		
	Channel 3 -		60	20		
	Channel 3gnd shld		36 (A1)	36		
S6-STP-A4	Channel 4 +	PLW-A6	59	4		
	Channel 4 -		71	21		
	Channel 4gnd shld		36 (A1)	37		
S6-STP-B1	Channel 5 +	PLW-A9	50	5		
	Channel 5 -		61	22		
	Channel 5gnd shld		36 (A1)	38		
S6-STP-B2	Channel 6 +	PLW-C9	62	6		
	Channel 6 -		51	23		
	Channel 6gnd shld		36 (A1)	39		



SPIRE HARNESS DEFINITION DOCUMENT (deltas)

Doc: SPIRE-RAL-PRJ-001819

	Name	Pixel	128Way #6	DCU J14	DCU J15	DCU J16
S6-STP-B3	Channel 7 +	PLW-B8	63	7		
	Channel 7 -		75	24		
	Channel 7gnd shld		36 (A1)	40		
S6-STP-B4	Channel 8 +	PLW-B7	74	8		
	Channel 8 -		73	25		
	Channel 8gnd shld		36 (A1)	41		
	GND WIRE		36 (A1)	9		
S6-STP-C1	Channel 9 +	PLW-C7	83	26		
	Channel 9 -		72	10		
	Channel 9gnd shld		36 (A1)	43		
S6-STP-C2	Channel 10 +	PLW-B5	95	27		
	Channel 10 -		84	11		
	Channel 10gnd shld		36 (A1)	44		
S6-STP-C3	Channel 11 +	PLW-B6	96	28		
	Channel 11 -		85	12		
	Channel 11gnd shld		36 (A1)	45		
S6-STP-C4	Channel 12 +	PLW-A5	106	29		
	Channel 12 -		107	13		
	Channel 12gnd shld		36 (A1)	46		
S6-STP-D1	Channel 13 +	PLW-T1	86	30		
	Channel 13 -		87	14		
	Channel 13gnd shld		36 (A1)	47		
S6-STP-D2	Channel 14 +	PLW-B4	97	31		
	Channel 14 -		98	15		
	Channel 14gnd shld		36 (A1)	48		
S6-STP-D3	Channel 15 +	PLW-C4	108	32		
	Channel 15 -		109	16		
	Channel 15gnd shld		36 (A1)	49		
S6-STP-D4	Channel 16 +	PLW-B3	116	33		
	Channel 16 -		117	17		
	Channel 16gnd shld		36 (A1)	50		
S6-STP-E1	Channel 17 +	PLW-C2	55		1	
	Channel 17 -		66		18	
	Channel 17gnd shld		128 (A2)		34	
S6-STP-E2	Channel 18 +	PLW-B2	67		2	
	Channel 18 -		78		19	
	Channel 18gnd shld		128 (A2)		35	
S6-STP-E3	Channel 19 +	PLW-B1	76		3	
	Channel 19 -		77		20	
	Channel 19gnd shld		128 (A2)		36	
S6-STP-E4	Channel 20 +	PLW-A3	88		4	
	Channel 20 -		89		21	
	Channel 20gnd shld		128 (A2)		37	
S6-STP-F1	Channel 21 +	PLW-A4	99		5	
	Channel 21 -		100		22	
	Channel 21gnd shld		128 (A2)		38	
S6-STP-F2	Channel 22 +	PLW-A1	110		6	
	Channel 22 -		111		23	
	Channel 22gnd shld		128 (A2)		39	
S6-STP-F3	Channel 23 +	PLW-DK1	118		7	
	Channel 23 -		119		24	
	Channel 23gnd shld		128 (A2)		40	
S6-STP-F4	Channel 24 +	PLW-A2	112		8	
	Channel 24 -		120		25	
	Channel 24gnd shld		128 (A2)		41	
	GND WIRE		128 (A2)	9		
S6-STP-G1	Channel 25 +	PLW-E1	90		26	
	Channel 25 -		79		10	
	Channel 25gnd shld		128 (A2)		43	
S6-STP-G2	Channel 26 +	PLW-E2	102		27	
	Channel 26 -		101		11	
	Channel 26gnd shld		128 (A2)		44	
S6-STP-G3	Channel 27 +	PLW-E3	92		28	
	Channel 27 -		91		12	
	Channel 27gnd shld		128 (A2)		45	
S6-STP-G4	Channel 28 +	PLW-E4	103		29	
	Channel 28 -		113		13	
	Channel 28gnd shld		128 (A2)		46	
S6-STP-H1	Channel 29 +	PLW-D1	58		30	
	Channel 29 -		46		14	
	Channel 29gnd shld		128 (A2)		47	



SPIRE HARNESS DEFINITION DOCUMENT (Deltas)

Doc: SPIRE-RAL-PRJ-001819

	Name	Pixel	128Way #6	DCU J14	DCU J15	DCU J16
S6-STP-H2	Channel 30 +	PLW-D2	68		31	
	Channel 30 -		57		15	
	Channel 30gnd shld		128 (A2)		48	
S6-STP-H3	Channel 31 +	PLW-D3	69		32	
	Channel 31 -		80		16	
	Channel 31gnd shld		128 (A2)		49	
S6-STP-H4	Channel 32 +	PLW-D4	70		33	
	Channel 32 -		81		17	
	Channel 32gnd shld		128 (A2)		50	
S6-STP-I1	Channel 33 +	PLW-C1	23			1
	Channel 33 -		34			18
	Channel 33gnd shld		4 (A3)			34
S6-STP-I2	Channel 34 +	PLW-C3	33			2
	Channel 34 -		45			19
	Channel 34gnd shld		4 (A3)			35
S6-STP-I3	Channel 35 +	PLW-C5	44			3
	Channel 35 -		56			20
	Channel 35gnd shld		4 (A3)			36
S6-STP-I4	Channel 36 +	PLW-T2	22			4
	Channel 36 -		32			21
	Channel 36gnd shld		4 (A3)			37
S6-STP-J1	Channel 37 +	PLW-E5	13			5
	Channel 37 -		12			22
	Channel 37gnd shld		4 (A3)			38
S6-STP-J2	Channel 38 +	PLW-C6	21			6
	Channel 38 -		20			23
	Channel 38gnd shld		4 (A3)			39
S6-STP-J3	Channel 39 +	PLW-C8	31			7
	Channel 39 -		43			24
	Channel 39gnd shld		4 (A3)			40
S6-STP-J4	Channel 40 +	PLW-D5	42			8
	Channel 40 -		54			25
	Channel 40gnd shld		4 (A3)			41
	GND WIRE		4 (A3)			9
S6-STP-K1	Channel 41 +	PLW-D6	10			26
	Channel 41 -		11			10
	Channel 41gnd shld		4 (A3)			43
S6-STP-K2	Channel 42 +	PLW-D7	19			27
	Channel 42 -		29			11
	Channel 42gnd shld		4 (A3)			44
S6-STP-K3	Channel 43 +	PLW-D8	41			28
	Channel 43 -		30			12
	Channel 43gnd shld		4 (A3)			45
S6-STP-K4	Channel 44 +	PLW-E7	53			29
	Channel 44 -		52			13
	Channel 44gnd shld		4 (A3)			46
S6-STP-L1	Channel 45 +	PLW-E6	9			30
	Channel 45 -		17			14
	Channel 45gnd shld		4 (A3)			47
S6-STP-L2	Channel 46 +	PLW-E8	18			31
	Channel 46 -		28			15
	Channel 46gnd shld		4 (A3)			48
S6-STP-L3	Channel 47 +	PLW-DK2	16			32
	Channel 47 -		27			16
	Channel 47gnd shld		4 (A3)			49
S6-STP-L4	Channel 48 +	PLW-E9	40			33
	Channel 48 -		39			17
	Channel 48gnd shld		4 (A3)			50
	Harness Overshield		EMC Backshell	EMC Backshell	EMC Backshell	EMC Backshell

FPU Faraday Shield Link Pins												
1	2	3	5	6	7	8	14	15	24	25	35	82
93	94	104	105	114	115	121	122	123	124	125	126	127

SMEC Control Tail Listing (FPU J29)

Function	37way J29	Max. current	Wire lay-up	Max Ohms	128Way #11
SMEC Drive Coil I+	1	100mA	Insulated screened twisted pair	5	12
SMEC Drive Coil I-	2	100mA		5	5
SMEC Drive Coil shld	20	N/A		N/A	A (13)
SMEC Drive Coil (Rob) I+	21	100mA	Insulated screened twisted pair	5	22
SMEC Drive Coil (Rob) I-	22	100mA		5	7
SMEC Drive Coil (Rob) shld	3	N/A		N/A	A (13)
SMEC Drive Coil Sense+	4	10 μ A	Insulated screened twisted pair	500	14
SMEC Drive Coil Sense-	5	10 μ A		500	24
SMEC Drive Coil shld	23	N/A		N/A	23
SMEC position sensor Led power supply	7	1mA	Insulated screened twisted pair	100	9
SMEC position sensor Led power return	8	1mA		100	2
SMEC position sensor Led power Shield	26	N/A		N/A	3
SMEC position sensor power supply	27	1mA	Insulated screened twisted pair	100	11
SMEC position sensor power return	28	1mA		100	4
SMEC position sensor power Shield	9	N/A		N/A	10
SMEC position sensor photodiode #1 I+	10	20 μ A	Insulated screened twisted pair	1000	18
SMEC position sensor photodiode #1 I-	11	20 μ A		1000	19
SMEC position sensor photodiode Shield	29	N/A		N/A	B (29)
SMEC pos. sensor photodiode #1 feedback +	30	10 μ A	Insulated screened twisted pair	1000	56
SMEC pos. sensor photodiode #1 feedback -	31	10 μ A		1000	55
SMEC pos. sensor photodiode feedback Shld	12	N/A		N/A	C (44)
SMEC position sensor photodiode #2 I+	13	20 μ A	Insulated screened twisted pair	1000	42
SMEC position sensor photodiode #2 I-	14	20 μ A		1000	41
SMEC position sensor photodiode Shield	32	N/A		N/A	B (30)
SMEC pos. sensor photodiode #2 feedback +	33	10 μ A	Insulated screened twisted pair	1000	34
SMEC pos. sensor photodiode #2 feedback -	34	10 μ A		1000	33
SMEC pos. sensor photodiode feedback Shld	15	N/A		N/A	C (45)
SMEC position sensor photodiode #3 I+	16	20 μ A	Insulated screened twisted pair	1000	20
SMEC position sensor photodiode #3 I-	17	20 μ A		1000	21
SMEC position sensor photodiode Shield	35	N/A		N/A	B (31)
SMEC pos. sensor photodiode #3 feedback +	36	10 μ A	Insulated screened twisted pair	1000	58
SMEC pos. sensor photodiode #3 feedback -	37	10 μ A		1000	57
SMEC pos. sensor photodiode feedback Shld	18	N/A		N/A	C (46)

29 contacts used.

SMEC above based on "Cryo_harness_010906.doc".

FPU Faraday Shield Link Pins (C11, I11 and S11)								
1	6	8	35	47	70	82	94	104
107	109	110	122	123	124	125	126	104



SPIRE HARNESS DEFINITION DOCUMENT (Deltas)

Doc: SPIRE-RAL-PRJ-001819

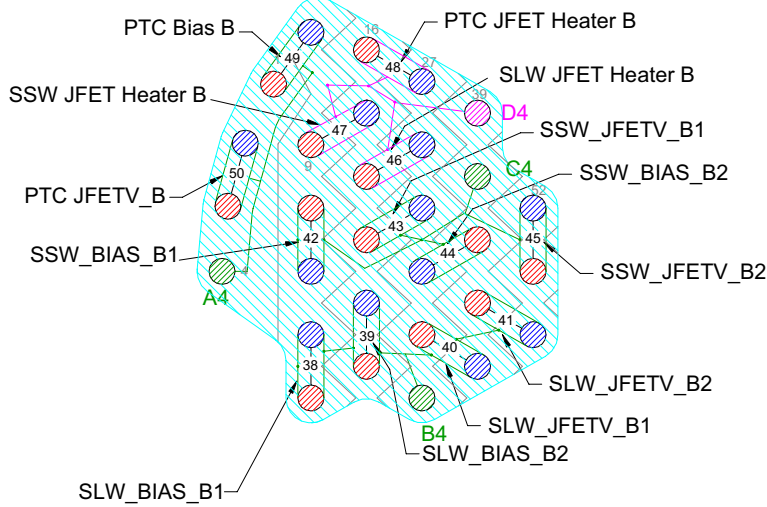

**Bias Tail B
(JFS P10)**

Contact details

	Name	Pixel	JFS P05	JFS P06	37-Way C JFS P09	37-Way D JFS P10	CVV 128-Way #1
C1-12ax-A	Channel 1 +	SLW-R1	1				26
	Channel 1 -		14				37
	Channel 1gnd shld		13 (A)				115 (A1)
	Channel 2 +	SLW-T1	2				38
	Channel 2 -		15				49
	Channel 2gnd shld		13 (A)				115 (A1)
	Channel 3 +	SLW-C1	3				48
	Channel 3 -		16				60
	Channel 3gnd shld		13 (A)				115 (A1)
	Channel 4 +	SLW-DK1	4				59
	Channel 4 -		17				71
	Channel 4gnd shld		13 (A)				115 (A1)
C1-12ax-B	Channel 5 +	SLW-B1	5				50
	Channel 5 -		18				61
	Channel 5gnd shld		13 (A)				115 (A1)
	Channel 6 +	SLW-D1	6				62
	Channel 6 -		19				51
	Channel 6gnd shld		13 (A)				115 (A1)
	Channel 7 +	SLW-E1	20				63
	Channel 7 -		7				75
	Channel 7gnd shld		13 (A)				115 (A1)
	Channel 8 +	SLW-A1	21				74
	Channel 8 -		8				73
	Channel 8gnd shld		13 (A)				115 (A1)
Channel 9 +	SLW-C2	22				83	
Channel 9 -		9				72	
Channel 9gnd shld		13 (A)				115 (A1)	
Channel 10 +	SLW-D2	23				95	
Channel 10 -		10				84	
Channel 10gnd shld		13 (A)				115 (A1)	
Channel 11 +	SLW-B2	24				96	
Channel 11 -		11				85	
Channel 11gnd shld		13 (A)				115 (A1)	
Channel 12 +	SLW-E2	25				106	
Channel 12 -		12				107	
Channel 12gnd shld		13 (A)				115 (A1)	
C1-12ax-D	Channel 13 +	SLW-A2		1			86
	Channel 13 -			14			87
	Channel 13gnd shld			13 (A)			122 (A2)
	Channel 14 +	SLW-C3		2			97
Channel 14 -			15			98	



SPIRE HARNESS DEFINITION DOCUMENT (Deltas)

Doc: SPIRE-RAL-PRJ-001819

	Name	Pixel	JFS P05	JFS P06	37-Way C JFS P09	37-Way D JFS P10	CVV 128-Way #1
	Channel 14gnd shld	SLW-D3		13 (A)			122 (A2)
	Channel 15 +			3			108
	Channel 15 -			16			109
	Channel 15gnd shld	SLW-B3		13 (A)			122 (A2)
	Channel 16 +			4			116
	Channel 16 -			17			117
Channel 16gnd shld	C1-12ax-E		13 (A)			122 (A2)	
Channel 17 +		SLW-E3		5			55
Channel 17 -				18			66
Channel 17gnd shld				13 (A)			122 (A2)
Channel 18 +		SLW-C4		6			67
Channel 18 -				19			78
Channel 18gnd shld				13 (A)			122 (A2)
Channel 19 +		SLW-DK2		20			76
Channel 19 -				7			77
Channel 19 gnd shld				13 (A)			122 (A2)
Channel 20 +		SLW-D4		21			88
Channel 20 -				8			89
Channel 20 gnd shld				13 (A)			122 (A2)
Channel 21 +		SLW-C5		22			99
Channel 21 -			9			100	
Channel 21gnd shld			13 (A)			122 (A2)	
Channel 22 +	SLW-B4		23			110	
Channel 22 -			10			111	
Channel 22gnd shld			13 (A)			122 (A2)	
Channel 23 +	SLW-A3		24			118	
Channel 23 -			11			119	
Channel 23gnd shld			13 (A)			122 (A2)	
Channel 24 +	SLW-T2		25			112	
Channel 24 -			12			120	
Channel 24gnd shld			13 (A)			122 (A2)	
STP	PTC Bias A +ve				1		7
	PTC Bias A -ve				20		14
	PTC Bias A Shield				2 (A3)		46 (A3)
⊘	PTC Ground A				2 (A3)		46 (A3)
STP	PTC JFETV Bias A +ve				21		24
	PTC JFETV Bias A -ve				3		35
	PTC JFETV Bias A Shield				2 (A3)		46 (A3)
STP	SLW BIAS A1+ve				22		121
	SLW BIAS A1-ve				4		114
	SLW BIAS A1 shld				6(B3)		104(B3)
STP	SLW BIAS A2 +ve				5		102
	SLW BIAS A2 -ve				24		101
	SLW BIAS A2 shld				23(B3)		104(B3)
STP	SLW JFETV A1 +ve				25		92
	SLW JFETV A1 -ve				7		91
	SLW JFETV A1 shld				6(B3)		104(B3)
STP	SLW JFETV A2 +ve				8		103
	SLW JFETV A2 -ve				27		113
	SLW JFETV A2 shld				26(B3)		104(B3)
⊘	SLW GND WIRE A				6(B3)		104(B3)
STP	SSW BIAS1 A +ve				28		90
	SSW BIAS1 A -ve				10		79
	SSW BIAS1 A shld				9(C3)		93(C3)
STP	SSW JFETV1 A +ve				11		68
	SSW JFETV1 A -ve				30		57
	SSW JFETV1 A shld				29(C3)		93(C3)
⊘	SSW GND WIRE A				12(C3)		93(C3)
STP	SSW BIAS2 A +ve				13		69
	SSW BIAS2 A -ve				32		80
	SSW BIAS2 A shld				31(C3)		93(C3)
STP	SSW JFETV2 A +ve				33		70
	SSW JFETV2 A -ve				15		81
	SSW JFETV2 A shld				14(C3)		93(C3)
S	S HEATER GROUND A				NC		22(D3)
STP	SLW JFET HEATER A +ve				17		23
	SLW JFET HEATER A -ve				36		34
	SLW JFET HEATER A shld				18(D3)		22(D3)
STP	SSW JFET HEATER A +ve				37		33
	SSW JFET HEATER A -ve				19		45



SPIRE HARNESS DEFINITION DOCUMENT (Deltas)

Doc: SPIRE-RAL-PRJ-001819

	Name	Pixel	JFS P05	JFS P06	37-Way C JFS P09	37-Way D JFS P10	CVV 128-Way #1
STP	SSW JFET HEATER A shld				18(D3)		22(D3)
	PTC JFET HEATER A +ve				16		44
	PTC JFET HEATER A -ve				35		56
	PTC JFET HEATER A shld				NC		22 (D3)
STP	PTC Bias B +ve					1	1
	PTC Bias B -ve					20	8
	PTC Bias B Shield					2 (A4)	4(A4)
S	PTC Ground B					2 (A4)	4(A4)
STP	PTC JFETV Bias B +ve					21	3
	PTC JFETV Bias B -ve					3	2
	PTC JFETV Bias B Shield					2 (A4)	4(A4)
STP	SLW BIAS B1+ve					22	13
	SLW BIAS B1-ve					4	12
	SLW BIAS B1 shld					6(B4)	32(B4)
STP	SLW BIAS B2+ve					5	21
	SLW BIAS B2 -ve					24	20
	SLW BIAS B2 shld					23(B4)	32(B4)
STP	SLW JFETV B1 +ve					25	31
	SLW JFETV B1 -ve					7	43
	SLW JFETV B1 shld					6(B4)	32(B4)
STP	SLW JFETV B2 +ve					8	42
	SLW JFETV B2 -ve					27	54
	SLW JFETV B2 shld					6(B4)	32(B4)
S	SLW GND WIRE B					6(B4)	32(B4)
S	SSW GND WIRE B					12(C4)	40(C4)
STP	SSW BIAS1 B +ve					28	10
	SSW BIAS1 B -ve					10	11
	SSW BIAS1 B shld					9(C4)	40(C4)
STP	SSW JFETV1 B +ve					11	19
	SSW JFETV1 B -ve					30	29
	SSW JFETV1 B shld					29(C4)	40(C4)
STP	SSW BIAS2 B +ve					13	41
	SSW BIAS2 B -ve					32	30
	SSW BIAS2 B shld					31(C4)	40(C4)
STP	SSW JFETV2 B +ve					33	53
	SSW JFETV2 B -ve					15	52
	SSW JFETV2 B shld					14(C4)	40 (C4)
S	S HEATER GROUND B					NC	39(D4)
STP	SLW HEATER B +ve					17	18
	SLW HEATER B -ve					36	28
	SLW HEATER B shld					18(D4)	39(D4)
STP	SSW HEATER B +ve					37	9
	SSW HEATER B -ve					19	17
	SSW HEATER B shld					18(D4)	39(D4)
STP	PTC JFET HEATER A +ve				16	16	
	PTC JFET HEATER A -ve				35	27	
	PTC JFET HEATER A shld				NC	39(D4)	
	Harness Overshield		EMC Backshell	EMC Backshell	EMC Backshell	EMC Backshell	

FPU Faraday Shield Link Pins S1/I1/C1								
5	6	15	22	25	36	39	47	58
82	94	105	123	124	125	126	127	128



SPIRE HARNESS DEFINITION DOCUMENT (Deltas)

Doc: SPIRE-RAL-PRJ-001819

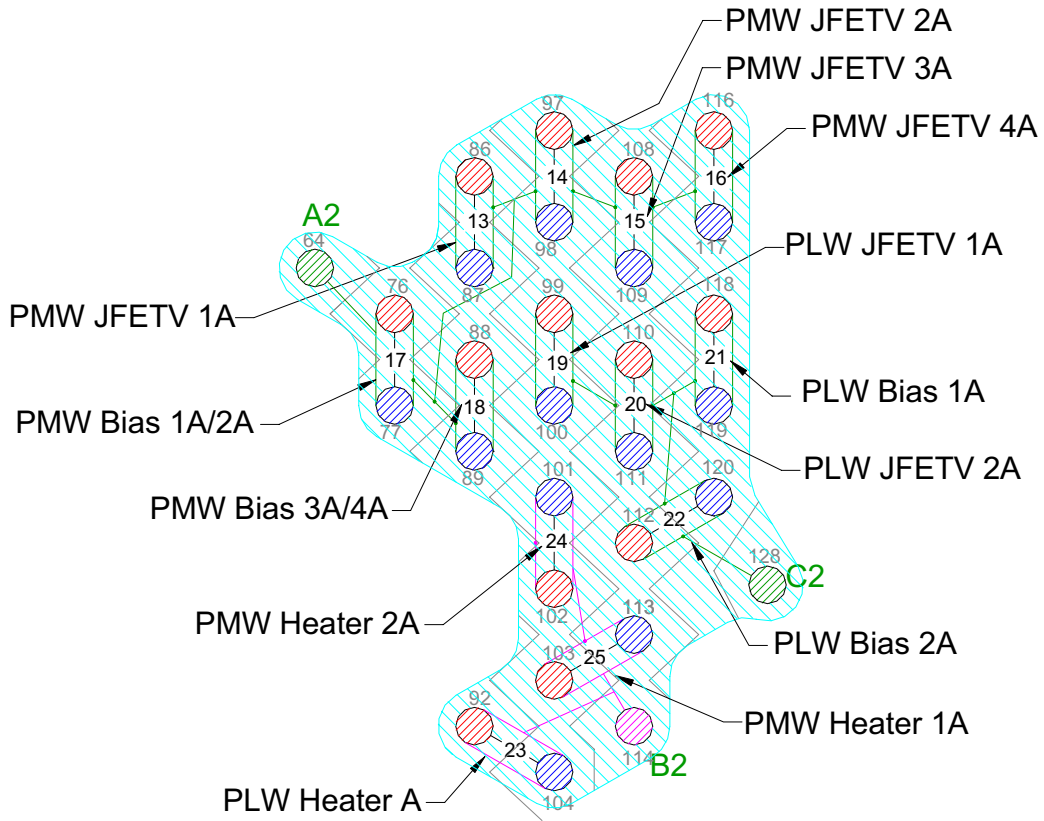

**PMW/PLW Biases A (JFP P27)
Prime**

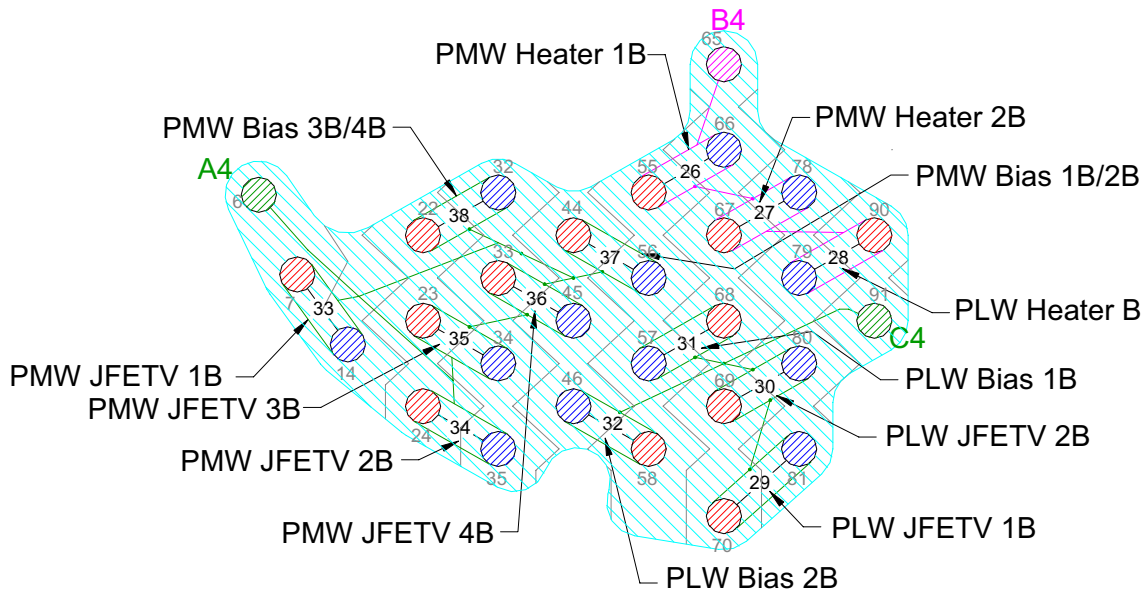

**PMW/PLW Biases B (JFP P28)
Redundant**



SPIRE HARNESS DEFINITION DOCUMENT (Deltas)

Doc: SPIRE-RAL-PRJ-001819

Contact Details

Name	37-way P25 (PSW Bias A)	37-way P27 (PMW/PLW Bias A)	37-Way P26 (PSW Bias B)	37-Way P28 (PMW/PLW Bias B)	128-Way #3
PSW JFETV1 A +	20				26
PSW JFETV1 A -	2				37
PSW JFETV1 A shld	1 (A1)				36 (A1)
PSW JFETV2 A +	3				38
PSW JFETV2 A -	22				49
PSW JFETV2 A shld	21 (A1)				36 (A1)
PSW JFETV3 A +	23				48
PSW JFETV3 A -	5				60
PSW JFETV3 A shld	4 (A1)				36 (A1)
PSW JFETV4 A +	6				59
PSW JFETV4 A -	25				71
PSW JFETV4 A shld	24 (A1)				36 (A1)
PSW JFETV5 A +	26				50
PSW JFETV5 A -	8				61
PSW JFETV5 A shld	7 (A1)				36 (A1)
PSW JFETV6 A +	9				62
PSW JFETV6 A -	28				51
PSW JFETV6 A shld	27 (A1)				36 (A1)
PSW GRND A	10 (A1)				36 (A1)
PSW BIAS1/2 A +	11				63
PSW BIAS1/2 A -	29				75
PSW BIAS1/2 A shld	30 (A1)				36 (A1)
PSW BIAS3/4 A +	31				74
PSW BIAS3/4 A -	12				73
PSW BIAS3/4 A shld	13 (A1)				36 (A1)
PSW BIAS5/6 A +	14				83
PSW BIAS5/6 A -	32				72
PSW BIAS5/6 A shld	33 (A1)				36 (A1)
PSW HEATER A1 +	34				95
PSW HEATER A1 -	15				84
PSW HEATER A1 shld	16 (B1)				105 (B1)
PSW HEATER A2 +	17				96
PSW HEATER A2 -	35				85
PSW HEATER A2 shld	36 (B1)				105 (B1)
PSW HEATER A3 +	37				106
PSW HEATER A3 -	18				107
PSW HEATER A3 shld	36 (B1)				105 (B1)
PMW JFETV1 A +		20			86
PMW JFETV1 A -		2			87
PMW JFETV1 A shld		1 (A2)			64 (A2)
PMW JFETV2 A +		3			97
PMW JFETV2 A -		22			98
PMW JFETV2 A shld		21 (A2)			64 (A2)
PMW JFETV3 A +		23			108
PMW JFETV3 A -		5			109
PMW JFETV3 A shld		4 (A2)			64 (A2)
PMW JFETV4 A +		6			116
PMW JFETV4 A -		25			117
PMW JFETV4 A shld		24 (A2)			64 (A2)
PMW BIAS1/2 A +		26			76
PMW BIAS1/2 A -		8			77
PMW BIAS1/2 A shld		7 (A2)			64 (A2)
PMW BIAS3/4 A +		27			88
PMW BIAS3/4 A -		9			89
PMW BIAS3/4 A shld		28 (A2)			64(A2)
PMW GND WIRE A		28 (A2)			64 (A2)
PMW HEATER A1 +		29			103
PMW HEATER A1 -		10			113
PMW HEATER A1 shld		11(B2)			114 (B2)
PMW HEATER A2 +		12			102
PMW HEATER A2 -		30			101
PMW HEATER A2 shld		11(B2)			114 (B2)
PLW HEATER A +		13			92
PLW HEATER A -		31			104
PLW HEATER A shld		11(B2)			93 (B2)



SPIRE HARNESS DEFINITION DOCUMENT (Deltas)

Doc: SPIRE-RAL-PRJ-001819

Name	37-way P25 (PSW Bias A)	37-way P27 (PMW/PLW Bias A)	37-Way P26 (PSW Bias B)	37-Way P28 (PMW/PLW Bias B)	128-Way #3
PLW JFETV1 A +		14			99
PLW JFETV1 A -		32			100
PLW JFETV1 A shld		33 (C2)			128 (C2)
PLW JFETV2 A +		34			110
PLW JFETV2 A -		15			111
PLW JFETV2 A shld		16 (C2)			128 (C2)
PLW BIAS1 A +		17			118
PLW BIAS1 A -		35			119
PLW BIAS1 A shld		36 (C2)			128 (C2)
PLW BIAS2 A +		37			112
PLW BIAS2 A -		18			120
PLW BIAS2 A shld		19 (C2)			128 (C2)
PLW GROUND WIRE A		19 (C2)			128 (C2)
PSW JFETV1 B +			20		42
PSW JFETV1 B -			2		54
PSW JFETV1 B shld			1 (A3)		1 (A3)
PSW JFETV2 B +			3		53
PSW JFETV2 B -			22		52
PSW JFETV2 B shld			21 (A3)		1 (A3)
PSW JFETV3 B +			23		41
PSW JFETV3 B -			5		30
PSW JFETV3 B shld			4 (A3)		1 (A3)
PSW JFETV4 B +			6		10
PSW JFETV4 B -			25		11
PSW JFETV4 B shld			24 (A3)		1 (A3)
PSW JFETV5 B +			26		19
PSW JFETV5 B -			8		29
PSW JFETV5 B shld			7 (A3)		1 (A3)
PSW JFETV6 B +			9		16
PSW JFETV6 B -			28		27
PSW JFETV6 B shld			27 (A3)		1 (A3)
PSW GRND B			10 (A3)		1 (A3)
PSW BIAS1/2 B +			11		40
PSW BIAS1/2 B -			29		39
PSW BIAS1/2 B shld			30 (A3)		1 (A3)
PSW BIAS3/4 B +			31		18
PSW BIAS3/4 B -			12		28
PSW BIAS3/4 B shld			13 (A3)		1 (A3)
PSW BIAS5/6 B +			14		9
PSW BIAS5/6 B -			32		17
PSW BIAS5/6 B shld			33 (A3)		1 (A3)
PSW HEATER B1 +			34		13
PSW HEATER B1 -			15		12
PSW HEATER B1 shld			16 (B3)		5 (B3)
PSW HEATER B2 +			17		21
PSW HEATER B2 -			35		20
PSW HEATER B2 shld			36 (B3)		5 (B3)
PSW HEATER B3 +			37		31
PSW HEATER B3 -			18		43
PSW HEATER B3 shld			36 (B3)		5 (B3)
PMW JFETV1 B +				20	7
PMW JFETV1 B -				2	14
PMW JFETV1 B shld				1 (A4)	6 (A4)
PMW JFETV2 B +				3	24
PMW JFETV2 B -				22	35
PMW JFETV2 B shld				21 (A4)	6 (A4)
PMW JFETV3 B +				23	23
PMW JFETV3 B -				5	34
PMW JFETV3 B shld				4 (A4)	6 (A4)
PMW JFETV4 B +				6	33
PMW JFETV4 B -				25	45
PMW JFETV4 B shld				24 (A4)	6 (A4)
PMW BIAS1/2 B +				26	44
PMW BIAS1/2 B -				8	56
PMW BIAS1/2 B shld				7 (A4)	6 (A4)
PMW BIAS3/4 B +				27	22
PMW BIAS3/4 B -				9	32
PMW BIAS3/4 B shld				28 (A4)	6 (A4)
PMW GND WIRE B				28 (A4)	6 (A4)
PMW HEATER B1 +				29	55



SPIRE HARNESS DEFINITION DOCUMENT (Deltas)

Doc SPIRE-RAL-PRJ-001819

Name	37-way P25 (PSW Bias A)	37-way P27 (PMW/PLW Bias A)	37-Way P26 (PSW Bias B)	37-Way P28 (PMW/PLW Bias B)	128-Way #3
PMW HEATER B1 -				10	66
PMW HEATER B1 shld				11 (B4)	65 (B4)
PMW HEATER B2 +				12	67
PMW HEATER B2 -				30	78
PMW HEATER B2 shld				11 (B4)	65 (B4)
PLW HEATER B +				13	90
PLW HEATER B -				31	79
PLW HEATER B shld				11 (B4)	65 (B4)
PLW JFETV1 B +				14	70
PLW JFETV1 B -				32	81
PLW JFETV1 B shld				33 (C4)	91 (C4)
PLW JFETV2 B +				34	69
PLW JFETV2 B -				15	80
PLW JFETV2 B shld				16 (C4)	91 (C4)
PLW BIAS1 B +				17	68
PLW BIAS1 B -				35	57
PLW BIAS1 B shld				36 (C4)	91 (C4)
PLW BIAS2 B +				37	58
PLW BIAS2 B -				18	46
PLW BIAS2 B shld				19 (C4)	91 (C4)
PLW GROUND WIRE B				19 (C4)	91 (C4)
Harness Over-shield	EMC Backshell	EMC Backshell	EMC Backshell	EMC Backshell	EMC Backshell

FPU Faraday Shield Link Pins

2	3	4	5	7	8	15	25	47	65	82	93	94
105	114	115	121	122	123	124	125	126	127	X	X	X



SPIRE HARNESS DEFINITION DOCUMENT (Deltas)

Doc: SPIRE-RAL-PRJ-001819

	Name	Pixel	JFP P13	JFP P14	JFP P15	JFP P16	128Way #6	
	Channel 7 -	PLW-B7	7				75	
	Channel 7gnd		13 (A1)				36 (A1)	
	Channel 8 +		21				74	
	Channel 8 -		8				73	
	Channel 8gnd		13 (A1)				36 (A1)	
C6-12ax-C	Channel 9 +	PLW-C7	22				83	
	Channel 9 -		9				72	
	Channel 9gnd		13 (A1)				36 (A1)	
	Channel 10 +	PLW-B5	23				95	
	Channel 10 -		10				84	
	Channel 10gnd		13 (A1)				36 (A1)	
	Channel 11 +	PLW-B6	24				96	
	Channel 11 -		11				85	
	Channel 11gnd		13 (A1)				36 (A1)	
	Channel 12 +	PLW-A5	25				106	
	Channel 12 -		12				107	
	Channel 12gnd		13 (A1)				36 (A1)	
	C6-12ax-D	Channel 13 +	PLW-T1		1			86
		Channel 13 -			14			87
Channel 13gnd				13 (A2)			128 (A2)	
Channel 14 +		PLW-B4		2			97	
Channel 14 -				15			98	
Channel 14gnd				13 (A2)			128 (A2)	
Channel 15 +		PLW-C4		3			108	
Channel 15 -				16			109	
Channel 15gnd				13 (A2)			128 (A2)	
Channel 16 +		PLW-B3		4			116	
Channel 16 -				17			117	
Channel 16gnd				13 (A2)			128 (A2)	
C6-12ax-E		Channel 17 +	PLW-C2		5			55
		Channel 17 -			18			66
	Channel 17gnd			13 (A2)			128 (A2)	
	Channel 18 +	PLW-B2		6			67	
	Channel 18 -			19			78	
	Channel 18gnd			13 (A2)			128 (A2)	
	Channel 19 +	PLW-B1		20			76	
	Channel 19 -			7			77	
	Channel 19gnd			13 (A2)			128 (A2)	
	Channel 20 +	PLW-A3		21			88	
	Channel 20 -			8			89	
	Channel 20gnd			13 (A2)			128 (A2)	
	C6-12ax-F	Channel 21 +	PLW-A4		22			99
		Channel 21 -			9			100
Channel 21gnd				13 (A2)			128 (A2)	
Channel 22 +		PLW-A1		23			110	
Channel 22 -				10			111	
Channel 22gnd				13 (A2)			128 (A2)	
Channel 23 +		PLW-DK1		24			118	
Channel 23 -				11			119	
Channel 23gnd				13 (A2)			128 (A2)	
Channel 24 +		PLW-A2		25			112	
Channel 24 -				12			120	
Channel 24gnd				13 (A2)			128 (A2)	
C6-12ax-G		Channel 25 +	PLW-E1			1		90
		Channel 25 -				14		79
	Channel 25gnd				13 (A3)		47 (A3)	
	Channel 26 +	PLW-E2			2		102	
	Channel 26 -				15		101	
	Channel 26gnd				13 (A3)		47 (A3)	
	Channel 27 +	PLW-E3			3		92	
	Channel 27 -				16		91	
	Channel 27gnd				13 (A3)		47 (A3)	
	Channel 28 +	PLW-E4			4		103	
	Channel 28 -				17		113	
	Channel 28gnd				13 (A3)		47 (A3)	
	C6-12ax-H	Channel 29 +	PLW-D1			5		58
		Channel 29 -				18		46
Channel 29gnd					13 (A3)		47 (A3)	
Channel 30 +		PLW-D2			6		68	
Channel 30 -					19		57	
	Channel 30gnd			13 (A3)		47 (A3)		

4.4.8 C8 CVV8 to HSJFP Type1

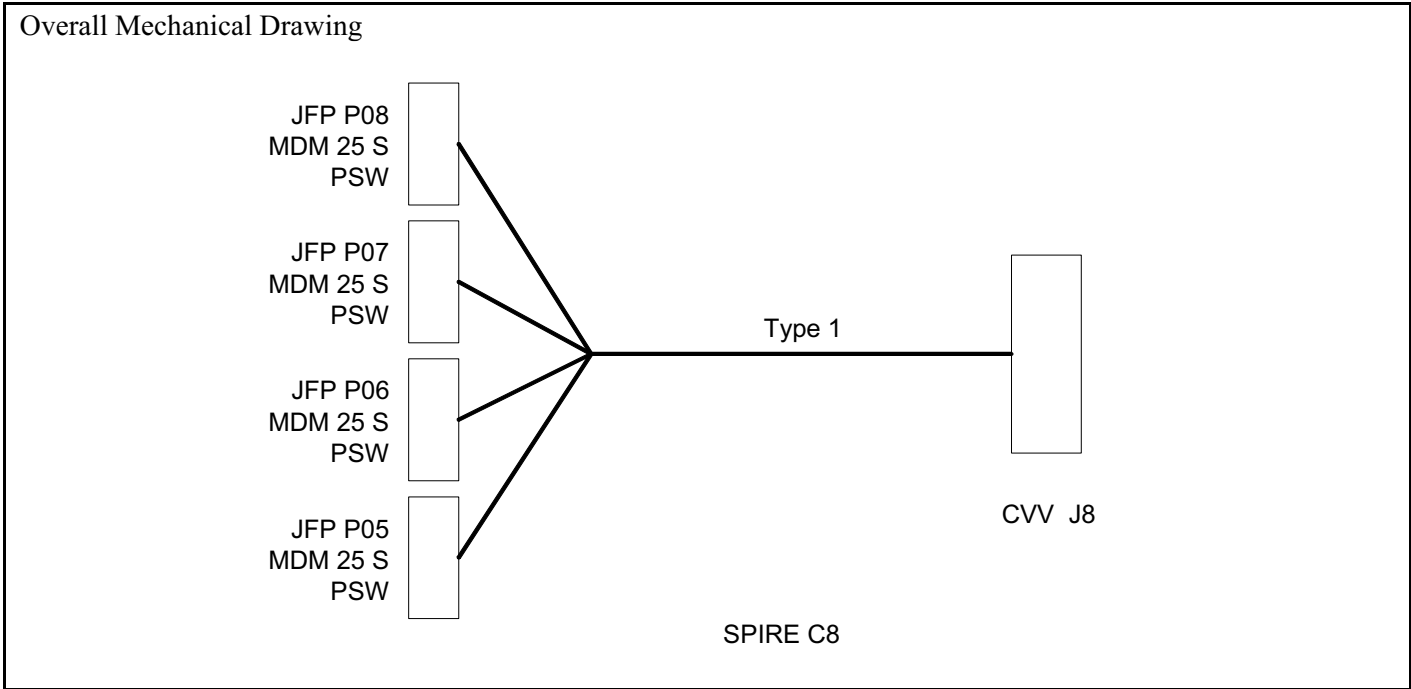

Connector/Backshell Details

MDM25S+Glenair507-T-139-M-37 to	JFP J5	PSW Signals
MDM25S+Glenair507-T-139-M-37 to	JFP J6	PSW Signals
MDM25S+Glenair507-T-139-M-37 to	JFP J7	PSW Signals
MDM25S+Glenair507-T-139-M-37 to	JFP J8	PSW Signals

Harness Layup

As C4.

	Name		JFP P05	JFP P06	JFP P07	JFP P08	128Way #8
C8-12ax-A	Channel 1 +	PSW-D6	1				26
	Channel 1 -		14				37
	Channel 1gnd		13 (A1)				36 (A1)
	Channel 2 +	PSW-B6	2				38
	Channel 2 -		15				49
	Channel 2gnd		13 (A1)				36 (A1)
	Channel 3 +	PSW-C5	3				48
	Channel 3 -		16				60
	Channel 3gnd		13 (A1)				36 (A1)
	Channel 4 +	PSW-A5	4				59
	Channel 4 -		17				71
	Channel 4gnd		13 (A1)				36 (A1)
C8-12ax-B	Channel 5 +	PSW-E5	5				50
	Channel 5 -		18				61
	Channel 5gnd		13 (A1)				36 (A1)
	Channel 6 +	PSW-B5	6				62
	Channel 6 -		19				51
	Channel 6gnd		13 (A1)				36 (A1)
	Channel 7 +	PSW-D5	20				63
	Channel 7 -		7				75
	Channel 7gnd		13 (A1)				36 (A1)
	Channel 8 +	PSW-C4	21				74
	Channel 8 -		8				73
	Channel 8gnd		13 (A1)				36 (A1)



SPIRE HARNESS DEFINITION DOCUMENT (Deltas)

Doc: SPIRE-RAL-PRJ-001819

	Name		JFP P05	JFP P06	JFP P07	JFP P08	128Way #8
C8-12ax-C	Channel 9 +	PSW-A4	22				83
	Channel 9 -		9				72
	Channel 9gnd		13 (A1)				36 (A1)
	Channel 10 +	PSW-D4	23				95
	Channel 10 -		10				84
	Channel 10gnd		13 (A1)				36 (A1)
	Channel 11 +	PSW-B4	24				96
	Channel 11 -		11				85
	Channel 11gnd		13 (A1)				36 (A1)
	Channel 12 +	PSW-C3	25				106
Channel 12 -	12					107	
Channel 12gnd	13 (A1)					36 (A1)	
C8-12ax-D	Channel 13 +	PSW-B3		1			86
	Channel 13 -			14			87
	Channel 13gnd			13 (A2)			128 (A2)
	Channel 14 +	PSW-A3		2			97
	Channel 14 -			15			98
	Channel 14gnd			13 (A2)			128 (A2)
	Channel 15 +	PSW-A2		3			108
	Channel 15 -			16			109
	Channel 15gnd			13 (A2)			128 (A2)
	Channel 16 +	PSW-D3		4			116
Channel 16 -			17			117	
Channel 16gnd			13 (A2)			128 (A2)	
C8-12ax-E	Channel 17 +	PSW-C2		5			55
	Channel 17 -			18			66
	Channel 17gnd			13 (A2)			128 (A2)
	Channel 18 +	PSW-B2		6			67
	Channel 18 -			19			78
	Channel 18gnd			13 (A2)			128 (A2)
	Channel 19 +	PSW-D2		20			76
	Channel 19 -			7			77
	Channel 19gnd			13 (A2)			128 (A2)
	Channel 20 +	PSW-A1		21			88
Channel 20 -			8			89	
Channel 20gnd			13 (A2)			128 (A2)	
C8-12ax-F	Channel 21 +	PSW-C1		22			99
	Channel 21 -			9			100
	Channel 21gnd			13 (A2)			128 (A2)
	Channel 22 +	PSW-B1		23			110
	Channel 22 -			10			111
	Channel 22gnd			13 (A2)			128 (A2)
	Channel 23 +	PSW-DK1		24			118
	Channel 23 -			11			119
	Channel 23gnd			13 (A2)			128 (A2)
	Channel 24 +	PSW-D1		25			112
Channel 24 -			12			120	
Channel 24gnd			13 (A2)			128 (A2)	
C8-12ax-G	Channel 25 +	PSW-F12			1		90
	Channel 25 -				14		79
	Channel 25gnd				13 (A3)		47 (A3)
	Channel 26 +	PSW-J11			2		102
	Channel 26 -				15		101
	Channel 26gnd				13 (A3)		47 (A3)
	Channel 27 +	PSW-E12			3		92
	Channel 27 -				16		91
	Channel 27gnd				13 (A3)		47 (A3)
	Channel 28 +	PSW-H12			4		103
Channel 28 -				17		113	
Channel 28gnd				13 (A3)		47 (A3)	
C8-12ax-H	Channel 29 +	PSW-G12			5		58
	Channel 29 -				18		46
	Channel 29gnd				13 (A3)		47 (A3)
	Channel 30 +	PSW-F13			6		68
	Channel 30 -				19		57
	Channel 30gnd				13 (A3)		47 (A3)
	Channel 31 +	PSW-E13			20		69
	Channel 31 -				7		80
Channel 31gnd				13 (A3)		47 (A3)	
Channel 32 +	PSW-J12			21		70	

Photometer Stimulus Heater P13

Function	P13	Max. Current	Wire Lay-up	MaxOhms	128Way #11
Photometer Point Stim. Heater I+ _A	2	7 mA	Screened twisted quad	10	48
Photometer Point Stim.Heater I+ _B	3	7 mA		10	71
Photometer Point Stim.Heater I- _A	7	7 mA		10	60
Photometer Point Stim.Heater I- _B	8	7 mA		10	59
Screen	4				36
Harness Overshield		EMC Backshell			

4 pins used

SMEC Launch Tail Listing (FCU P29)

Function	Signal Name	37-Way P29	Max. Current	Wire lay-up	Max Ohms	128Way #11
SMEC launch latch #1 power supply A	S_LL#1_Coil_P	1	400 mA / 50ms	Insulated screened twisted pair	5	67
SMEC launch latch #1 power return A	S_LL#1_Coil_N	2	400 mA / 50ms		5	66
SMEC launch latch #1 power Shield A	S_LL#1_Coil_Shld	20	N/A		N/A	78
SMEC launch latch #1 power supply B		21	400 mA / 50ms	Insulated screened twisted pair	5	69
SMEC launch latch #1 power return B		22	400 mA / 50ms		5	68
SMEC launch latch #1 power Shield B		3	N/A		N/A	80
SMEC launch latch #2 power supply A		4	400 mA / 50ms	Insulated screened twisted pair	5	90
SMEC launch latch #2 power return A		5	400 mA / 50ms		5	91
SMEC launch latch #2 power Shield A		23	N/A		N/A	79
SMEC launch latch #2 power supply B	S_LL#2_Coil_P	24	400 mA / 50ms	Insulated screened twisted pair	5	92
SMEC launch latch #2 power return B	S_LL#2_Coil_N	25	400 mA / 50ms		5	93
SMEC launch latch #2 power Shield B	S_LL#2_Coil_Shld	6	N/A		N/A	81
SMEC LVDT primary coil power supply (P)	LVDT_PRIM_P	13	5 mA	Insulated screened twisted pair	5	101
SMEC LVDT primary coil power supply (N)	LVDT_PRIM_N	14	5 mA		5	102
SMEC LVDT primary coil power supply Shld	LVDT_PRIM_Shld	32	N/A		N/A	112
SMEC LVDT secondary coil # 1 signal (P)	LVDT_SECA_P	15	50 μ A	Insulated screened twisted pair	5	127
SMEC LVDT secondary coil # 1 signal (N)	LVDT_SECA_N	16	50 μ A		5	120
SMEC LVDT secondary coil # 1 signal Shield	LVDT_SECA_Shld	34	N/A		N/A	128
SMEC LVDT secondary coil # 2 signal (P)	LVDT_SECB_P	17	50 μ A	Insulated screened twisted pair	5	114
SMEC LVDT secondary coil # 2 signal (N)	LVDT_SECB_N	18	50 μ A		5	113
SMEC LVDT secondary coil # 2 signal Shield	LVDT_SECB_Shld	36	N/A		N/A	121
Harness Overshield		EMC Backshell				



SPIRE HARNESS DEFINITION DOCUMENT (Deltas)

Doc: SPIRE-RAL-PRJ-001819

	Name	Pixel	JFP P01	JFP P02	JFP P03	JFP P04	128Way #9	
	Channel 6 -	PSW-D15	19				51	
	Channel 6gnd		13 (A1)				36 (A1)	
	Channel 7 +		20				63	
	Channel 7 -		7				75	
	Channel 7gnd		13 (A1)				36 (A1)	
	Channel 8 +		PSW-B15	21				74
	Channel 8 -			8				73
Channel 8gnd	13 (A1)					36 (A1)		
C9-12ax-C	Channel 9 +	PSW-C14	22				83	
	Channel 9 -		9				72	
	Channel 9gnd		13 (A1)				36 (A1)	
	Channel 10 +	PSW-D14	23				95	
	Channel 10 -		10				84	
	Channel 10gnd	PSW-A14	13 (A1)				36 (A1)	
	Channel 11 +		24				96	
	Channel 11 -		11				85	
	Channel 11gnd	PSW-A13	13 (A1)				36 (A1)	
	Channel 12 +		25				106	
Channel 12 -	12					107		
Channel 12gnd	13 (A1)					36 (A1)		
C9-12ax-D	Channel 13 +	PSW-B14		1			86	
	Channel 13 -			14			87	
	Channel 13gnd			13 (A2)			128 (A2)	
	Channel 14 +	PSW-C13		2			97	
	Channel 14 -			15			98	
	Channel 14gnd			13 (A2)			128 (A2)	
	Channel 15 +	PSW-B13		3			108	
	Channel 15 -			16			109	
	Channel 15gnd			13 (A2)			128 (A2)	
	Channel 16 +	PSW-D13		4			116	
Channel 16 -			17			117		
Channel 16gnd			13 (A2)			128 (A2)		
C9-12ax-E	Channel 17 +	PSW-A12		5			55	
	Channel 17 -			18			66	
	Channel 17gnd			13 (A2)			128 (A2)	
	Channel 18 +	PSW-C12		6			67	
	Channel 18 -			19			78	
	Channel 18gnd			13 (A2)			128 (A2)	
	Channel 19 +	PSW-D12		20			76	
	Channel 19 -			7			77	
	Channel 19gnd			13 (A2)			128 (A2)	
	Channel 20 +		PSW-B12		21			88
Channel 20 -		8				89		
Channel 20gnd		13 (A2)				128 (A2)		
C9-12ax-F	Channel 21 +	PSW-E11		22			99	
	Channel 21 -			9			100	
	Channel 21gnd			13 (A2)			128 (A2)	
	Channel 22 +	PSW-A11		23			110	
	Channel 22 -			10			111	
	Channel 22gnd			13 (A2)			128 (A2)	
	Channel 23 +	PSW-C11		24			118	
	Channel 23 -			11			119	
	Channel 23gnd			13 (A2)			128 (A2)	
Channel 24 +	PSW-B11		25			112		
Channel 24 -			12			120		
Channel 24gnd			13 (A2)			128 (A2)		
C9-12ax-G	Channel 25 +	PSW-E1			1		90	
	Channel 25 -				14		79	
	Channel 25gnd				13 (A3)		47 (A3)	
	Channel 26 +	PSW-F1			2		102	
	Channel 26 -				15		101	
	Channel 26gnd				13 (A3)		47 (A3)	
	Channel 27 +	PSW-T2			3		92	
	Channel 27 -				16		91	
	Channel 27gnd				13 (A3)		47 (A3)	
	Channel 28 +	PSW-H1			4		103	
Channel 28 -				17		113		
Channel 28gnd				13 (A3)		47 (A3)		
C9-12ax-H	Channel 29 +	PSW-G1			5		58	
	Channel 29 -				18		46	

Pin Allocation List (Harness)

Connector: 312100 P03

Function: SPIRE SVM CB1 (SPIRE Bundle 04)

Conn.-Type: MS27484T24F-35S (PI+ShI)

Item: HSSVMCB1

Location: 27 / I/F CB ab. SVM Panel 7 (SPI/CCU CB)

Backshell: 380 FS 007 M24 05

EMC-Category: 2S/Sig H fr SVMCB to W. Units

Pin	Signal Designation	Interface-Code			Ch. ID	Wiring	Grouping:			Comment	Target-Item	Location	Connector	Pin	New
		Circuit	Signal	Pos.			Shd	Cable	Twist						
078	SPIRE PMW Ch17 to 19 . 18-		SPB.5	-	S073	021CC-28	5				HSDCU	17	122300 P20	016	
128	SPIRE PMW Ch17 to 19 . 18gnd		SPB.5	-	S073	021CC-28	5			Daisy ch to Pin 128 (A3)	HSDCU	17	122300 P20	049	
076	SPIRE PMW Ch17 to 19 . 19+		SPB.5	-	S073	021CC-28	5			PMW-E9	HSDCU	17	122300 P20	033	
077	SPIRE PMW Ch17 to 19 . 19-		SPB.5	-	S073	021CC-28	5				HSDCU	17	122300 P20	017	
128	SPIRE PMW Ch17 to 19 . 19gnd		SPB.5	-	S073	021CC-28	5			Daisy ch to Pin 128 (A3)	HSDCU	17	122300 P20	050	
-	P20 Cable Faraday shd									Cable P20 Faraday Shd con to Busbar					
-	P20 Insulating Jacket									Cable P20 Insulating Jacket tbd					
-	P20 Cable Overall Shd									Cable P20 Overall Shd not forseen, may be added later					
088	SPIRE PMW Ch 20 . 20+		SPB.3	-	S73A	021CC-28	5			PMW-G9	HSDCU	17	122300 P21	001	
089	SPIRE PMW Ch 20 . 20-		SPB.3	-	S73A	021CC-28	5				HSDCU	17	122300 P21	018	
128	SPIRE PMW Ch 20 . 20gnd		SPB.3	-	S73A	021CC-28	5			Daisy ch to Pin 128 (A3)	HSDCU	17	122300 P21	034	
099	SPIRE PMW Ch21 to 24 . 21+		SPB.S	-	S074	021CC-28	6			PMW-D9	HSDCU	17	122300 P21	002	
100	SPIRE PMW Ch21 to 24 . 21-		SPB.S	-	S074	021CC-28	6				HSDCU	17	122300 P21	019	
128	SPIRE PMW Ch21 to 24 . 21gnd		SPB.S	-	S074	021CC-28	6			Daisy ch to Pin 128 (A3)	HSDCU	17	122300 P21	035	
110	SPIRE PMW Ch21 to 24 . 22+		SPB.S	-	S074	021CC-28	6			PMW-F9	HSDCU	17	122300 P21	003	
111	SPIRE PMW Ch21 to 24 . 22-		SPB.S	-	S074	021CC-28	6				HSDCU	17	122300 P21	020	
128	SPIRE PMW Ch21 to 24 . 22gnd		SPB.S	-	S074	021CC-28	6			Daisy ch to Pin 128 (A3)	HSDCU	17	122300 P21	036	
118	SPIRE PMW Ch21 to 24 . 23+		SPB.S	-	S074	021CC-28	6			PMW-E10	HSDCU	17	122300 P21	004	
119	SPIRE PMW Ch21 to 24 . 23-		SPB.S	-	S074	021CC-28	6				HSDCU	17	122300 P21	021	
128	SPIRE PMW Ch21 to 24 . 23gnd		SPB.S	-	S074	021CC-28	6			Daisy ch to Pin 128 (A3)	HSDCU	17	122300 P21	037	
112	SPIRE PMW Ch21 to 24 . 24+		SPB.S	-	S074	021CC-28	6			PMW-G10	HSDCU	17	122300 P21	005	
120	SPIRE PMW Ch21 to 24 . 24-		SPB.S	-	S074	021CC-28	6				HSDCU	17	122300 P21	022	
128	SPIRE PMW Ch21 to 24 . 24gnd		SPB.S	-	S074	021CC-28	6			Daisy ch to Pin 128 (A3)	HSDCU	17	122300 P21	038	
090	SPIRE PMW Ch25 to 28 . 25+		SPB.S	-	S076	021CC-28	8			PMW-C4	HSDCU	17	122300 P21	006	

These two corrections are as per SPIRE HDD 1.2

Pin Allocation List (Harness)

Connector: 312100 P03

Function: SPIRE SVM CB1 (SPIRE Bundle 04)

Conn.-Type: MS27484T24F-35S (PI+ShI)

Item: HSSVMCB1

Location: 27 / I/F CB ab. SVM Panel 7 (SPI/CCU CB)

Backshell: 380 FS 007 M24 05

EMC-Category: 2S/Sig H fr SVMCB to W. Units

Pin	Signal Designation	Interface-Code			Ch. ID	Wiring	Grouping:			Comment	Target-Item	Location	Connector	Pin	New
		Circuit	Signal	Pos.			Shd	Cable	Twist						
078	SPIRE PMW Ch17 to 19 . 18-		SPB.5 -		S073	021CC-28	5				HSDCU	17	122300 P20	016	
128	SPIRE PMW Ch17 to 19 . 18gnd		SPB.5 -		S073	021CC-28	5			Daisy ch to Pin 128 (A3)	HSDCU	17	122300 P20	049	
076	SPIRE PMW Ch17 to 19 . 19+		SPB.5 -		S073	021CC-28	5			PMW-E9	HSDCU	17	122300 P20	033	
077	SPIRE PMW Ch17 to 19 . 19-		SPB.5 -		S073	021CC-28	5				HSDCU	17	122300 P20	017	
128	SPIRE PMW Ch17 to 19 . 19gnd		SPB.5 -		S073	021CC-28	5			Daisy ch to Pin 128 (A3)	HSDCU	17	122300 P20	050	
-	P20 Cable Faraday shd									Cable P20 Faraday Shd con to Busbar					
-	P20 Insulating Jacket									Cable P20 Insulating Jacket tbd					
-	P20 Cable Overall Shd									Cable P20 Overall Shd not forseen, may be added later					
088	SPIRE PMW Ch 20 . 20+		SPB.3 -		S73A	021CC-28	5			PMW-G9	HSDCU	17	122300 P21	001	
089	SPIRE PMW Ch 20 . 20-		SPB.3 -		S73A	021CC-28	5				HSDCU	17	122300 P21	018	
128	SPIRE PMW Ch 20 . 20gnd		SPB.3 -		S73A	021CC-28	5			Daisy ch to Pin 128 (A3)	HSDCU	17	122300 P21	034	
099	SPIRE PMW Ch21 to 24 . 21+		SPB.S -		S074	021CC-28	6			PMW-D9	HSDCU	17	122300 P21	002	
100	SPIRE PMW Ch21 to 24 . 21-		SPB.S -		S074	021CC-28	6				HSDCU	17	122300 P21	019	
128	SPIRE PMW Ch21 to 24 . 21gnd		SPB.S -		S074	021CC-28	6			Daisy ch to Pin 128 (A3)	HSDCU	17	122300 P21	035	
110	SPIRE PMW Ch21 to 24 . 22+		SPB.S -		S074	021CC-28	6			PMW-F9	HSDCU	17	122300 P21	003	
111	SPIRE PMW Ch21 to 24 . 22-		SPB.S -		S074	021CC-28	6				HSDCU	17	122300 P21	020	
128	SPIRE PMW Ch21 to 24 . 22gnd		SPB.S -		S074	021CC-28	6			Daisy ch to Pin 128 (A3)	HSDCU	17	122300 P21	036	
118	SPIRE PMW Ch21 to 24 . 23+		SPB.S -		S074	021CC-28	6			PMW-E10	HSDCU	17	122300 P21	004	
119	SPIRE PMW Ch21 to 24 . 23-		SPB.S -		S074	021CC-28	6				HSDCU	17	122300 P21	021	
128	SPIRE PMW Ch21 to 24 . 23gnd		SPB.S -		S074	021CC-28	6			Daisy ch to Pin 128 (A3)	HSDCU	17	122300 P21	037	
112	SPIRE PMW Ch21 to 24 . 24+		SPB.S -		S074	021CC-28	6			PMW-G10	HSDCU	17	122300 P21	005	
120	SPIRE PMW Ch21 to 24 . 24-		SPB.S -		S074	021CC-28	6				HSDCU	17	122300 P21	022	
128	SPIRE PMW Ch21 to 24 . 24gnd		SPB.S -		S074	021CC-28	6			Daisy ch to Pin 128 (A3)	HSDCU	17	122300 P21	038	
090	SPIRE PMW Ch25 to 28 . 25+		SPB.S -		S076	021CC-28	8			PMW-C4	HSDCU	17	122300 P21	006	

Compliant with
SPIRE HDD 1.2

Pin Allocation List (Harness)

Connector: 211121 J22
Item: CVVUCR
EMC-Category: 2C/Sig H in Cryostat

Function: UFThr 193.0° (SPIRE XS-04JFP21,22,23,24)
Location: 33 / CVV I/F CB Top PFM (CVVUCR)

Conn.-Type: 197-011P24-35P (Junct.)
Backshell: HERSKT 58-0050

Pin	Signal Designation	Interface-Code			Ch. ID	Wiring	Grouping:			Comment	Target-Item	Location	Connector	Pin	New
		Circuit	Signal	Pos.			Shd	Cable	Twist						
108	SPIRE PMW Ch 13 to 16 . 15+		SPB.-	-	S072	12AXD-38	4	D		PMW-F7	HSJFP	75	121210 P23	003	
109	SPIRE PMW Ch 13 to 16 . 15-		SPB.-	-	S072	12AXD-38	4	D			HSJFP	75	121210 P23	016	
128	SPIRE PMW Ch 13 to 16 . 15gnd		SPB.-	-	S072	12AXD-38	4	D		Daisy ch to Pin 128 (A2)	HSJFP	75	121210 P23	013	
-															
116	SPIRE PMW Ch 13 to 16 . 16+		SPB.-	-	S072	12AXD-38	4	D		PMW-E8	HSJFP	75	121210 P23	004	
117	SPIRE PMW Ch 13 to 16 . 16-		SPB.-	-	S072	12AXD-38	4	D			HSJFP	75	121210 P23	017	
128	SPIRE PMW Ch 13 to 16 . 16gnd		SPB.-	-	S072	12AXD-38	4	D		Daisy ch to Pin 128 (A2)	HSJFP	75	121210 P23	013	
128	SPIRE PMW Ch 13 to 16 . SHD01		SPB.-	-	S072	12AXD-38	4	D		Cable S072 inner Shd daisy ch to Pin 128 (A2)	HSJFP	75	121210 P23	013	
-	Cable S072 12 AXD Outer Shield									Cable S072 outer Shd con to Busbar (Faraday)					
-															
-															
055	SPIRE PMW Ch17 to 19 . 17+		SPB.-	-	S073	12AXD-38	5	E		PMW-G8	HSJFP	75	121210 P23	005	
066	SPIRE PMW Ch17 to 19 . 17-		SPB.-	-	S073	12AXD-38	5	E			HSJFP	75	121210 P23	018	
128	SPIRE PMW Ch17 to 19 . 17gnd		SPB.-	-	S073	12AXD-38	5	E		Daisy ch to Pin 128 (A2)	HSJFP	75	121210 P23	013	
067	SPIRE PMW Ch17 to 19 . 18+		SPB.-	-	S073	12AXD-38	5	E		PMW-F8	HSJFP	75	121210 P23	006	
078	SPIRE PMW Ch17 to 19 . 18-		SPB.-	-	S073	12AXD-38	5	E			HSJFP	75	121210 P23	019	
128	SPIRE PMW Ch17 to 19 . 18gnd		SPB.-	-	S073	12AXD-38	5	E		Daisy ch to Pin 128 (A2)	HSJFP	75	121210 P23	013	
-															
076	SPIRE PMW Ch17 to 19 . 19+		SPB.-	-	S073	12AXD-38	5	E		PMW-E9	HSJFP	75	121210 P23	020	
077	SPIRE PMW Ch17 to 19 . 19-		SPB.-	-	S073	12AXD-38	5	E			HSJFP	75	121210 P23	007	
128	SPIRE PMW Ch17 to 19 . 19gnd		SPB.-	-	S073	12AXD-38	5	E		Daisy ch to Pin 128 (A2)	HSJFP	75	121210 P23	013	
-															
088	SPIRE PMW Ch 20 . 20+		SPB.-	-	S73A	12AXD-38	5	E		PMW-G9	HSJFP	75	121210 P23	021	
089	SPIRE PMW Ch 20 . 20-		SPB.-	-	S73A	12AXD-38	5	E			HSJFP	75	121210 P23	008	
128	SPIRE PMW Ch 20 . 20gnd		SPB.-	-	S73A	12AXD-38	5	E		Daisy ch to Pin 128 (A2)	HSJFP	75	121210 P23	013	
128	SPIRE PMW Ch17 to 19 . SHD02		SPB.-	-	S073	12AXD-38	5	E		Cable S073 inner Shd daisy ch to Pin 128 (A2)	HSJFP	75	121210 P23	013	
-	Cable S073 12 AXD Outer Shield									Cable S063 outer Shd con to Busbar (Faraday)					
-															
-															
099	SPIRE PMW Ch21 to 24 . 21+		SPB.-	-	S074	12AXD-38	6	F		PMW-D9	HSJFP	75	121210 P23	022	
100	SPIRE PMW Ch21 to 24 . 21-		SPB.-	-	S074	12AXD-38	6	F			HSJFP	75	121210 P23	009	
128	SPIRE PMW Ch21 to 24 . 21gnd		SPB.-	-	S074	12AXD-38	6	F		Daisy ch to Pin 128 (A2)	HSJFP	75	121210 P23	013	
-															
110	SPIRE PMW Ch21 to 24 . 22+		SPB.-	-	S074	12AXD-38	6	F		PMW-F9	HSJFP	75	121210 P23	023	

No worries - compliant with SPIRE HDD 1.2

Pin Allocation List (Harness)

Connector: 312300 P04

Function: SPIRE SVM CB3 (SPIRE Bundle 11)

Conn.-Type: MS27484T24F-35S (PI+ShI)

Item: HSSVMCB3

Location: 27 / I/F CB ab. SVM Panel 7 (SPI/CCU CB)

Backshell: 380 FS 007 M24 05

EMC-Category: 2S/Sig H fr SVMCB to W. Units

Pin	Signal Designation	Interface-Code			Ch. ID	Wiring	Grouping:			Comment	Target-Item	Location	Connector	Pin	New
		Circuit	Signal	Pos.			Shd	Cable	Twist						
-															
014	SPIRE SMEC Drv Sense (N) . Sen+		SMG.S -		S278	021CC-28	24				HSFCU	17	122200 P17	004	
024	SPIRE SMEC Drv Sense (N) . Sen-		SMG.S -		S278	021CC-28	24				HSFCU	17	122200 P17	005	
023	SPIRE SMEC Drv Sense (N) . SHD03		SMG.S -		S278	021CC-28	24		Cable S278 Shd		HSFCU	17	122200 P17	023	
-															
009	SPIRE SMEC PosSeLEDpwr(N) . S		SMH.S -		S279	021CC-28	25				HSFCU	17	122200 P17	007	
002	SPIRE SMEC PosSeLEDpwr(N) . R		SMH.S -		S279	021CC-28	25				HSFCU	17	122200 P17	008	
003	SPIRE SMEC PosSeLEDpwr(N) . SHD04		SMH.S -		S279	021CC-28	25		Cable S279 Shd		HSFCU	17	122200 P17	026	
-															
011	SPIRE SMEC PosSensPwr(N) . S		SMH.S -		S280	021CC-28	26				HSFCU	17	122200 P17	027	
004	SPIRE SMEC PosSensPwr(N) . R		SMH.S -		S280	021CC-28	26				HSFCU	17	122200 P17	028	
010	SPIRE SMEC PosSensPwr(N) . SHD05		SMH.S -		S280	021CC-28	26		Cable S280 Shd		HSFCU	17	122200 P17	009	
-															
018	SPIRE SMEC PosPhDi#1FB(N) . S		SMJ.S -		S281	021CC-28	27				HSFCU	17	122200 P17	010	
019	SPIRE SMEC PosPhDi#1FB(N) . R		SMJ.S -		S281	021CC-28	27				HSFCU	17	122200 P17	011	
029	SPIRE SMEC PosPhDi#1FB(N) . SHD09		SMJ.S -		S281	021CC-28	27		Cable S281Shd		HSFCU	17	122200 P17	029	
-															
056	SPIRE SMEC PosPhDi#1FB(N) . S		SMK.S -		S282	021CC-28	30				HSFCU	17	122200 P17	030	
055	SPIRE SMEC PosPhDi#1FB(N) . R		SMK.S -		S282	021CC-28	30				HSFCU	17	122200 P17	031	
044	SPIRE SMEC PosPhDi#1FB(N) . SHD09		SMK.S -		S282	021CC-28	30		Cable S282 Shd		HSFCU	17	122200 P17	012	
-															
042	SPIRE SMEC PosPhDi#2(N) . I+		SMJ.S -		S283	021CC-28	28				HSFCU	17	122200 P17	013	
041	SPIRE SMEC PosPhDi#2(N) . I-		SMJ.S -		S283	021CC-28	28				HSFCU	17	122200 P17	014	
030	SPIRE SMEC PosPhDi#2(N) . SHD07		SMJ.S -		S283	021CC-28	28		Cable S283 Shd		HSFCU	17	122200 P17	032	
-															
034	SPIRE SMEC PosPhDi#2FB(N) . S		SMK.S -		S284	021CC-28	31				HSFCU	17	122200 P17	033	
033	SPIRE SMEC PosPhDi#2FB(N) . R		SMK.S -		S284	021CC-28	31				HSFCU	17	122200 P17	034	
045	SPIRE SMEC PosPhDi#2FB(N) . SHD10		SMK.S -		S284	021CC-28	31		Cable S284 Shd		HSFCU	17	122200 P17	015	
-															
020	SPIRE SMEC PosPhDi#3(N) . I+		SMJ.S -		S285	021CC-28	29				HSFCU	17	122200 P17	016	
021	SPIRE SMEC PosPhDi#3(N) . I-		SMJ.S -		S285	021CC-28	29				HSFCU	17	122200 P17	017	
031	SPIRE SMEC PosPhDi#3(N) . SHD08		SMJ.S -		S285	021CC-28	29		Cable S285 Shd		HSFCU	17	122200 P17	035	
-															

This matches the interface to the FPU

The pin allocations on the S/C 128-way connectors all match

Pin Allocation List (Harness)

Connector: 211121 J30
Item: CVVUCR
EMC-Category: 2C/Sig H in Cryostat

Function: UFThr. 283.0° (SPIRE XS-11 FPU 25,27,29)
Location: 33 / CVV I/F CB Top PFM (CVVUCR)

Conn.-Type: 197-011P24-35P (Junct.)
Backshell: HERSKT 58-0050

Pin	Signal Designation	Interface-Code			Ch. ID	Wiring	Grouping:			Comment	Target-Item	Location	Connector	Pin	New
		Circuit	Signal	Pos.			Shd	Cable	Twist						
-	-														
011	SPIRE SMEC PosSensPwr(N) . S		SMH.-	-	S280	021BS-38	26				HSFPU	70	121100 P29	027	
004	SPIRE SMEC PosSensPwr(N) . R		SMH.-	-	S280	021BS-38	26				HSFPU	70	121100 P29	028	
010	SPIRE SMEC PosSensPwr(N) . SHD05		SMH.-	-	S280	021BS-38	26		Cable S280 Shd		HSFPU	70	121100 P29	009	
-	-														
018	SPIRE		SMJ.-	-	S281	021SS-38	27				HSFPU	70	121100 P29	018	
019	SPIRE		SMJ.-	-	S281	021SS-38	27				HSFPU	70	121100 P29	019	
029	SPIRE		SMJ.-	-	S281	021SS-38	27		Cable S281, 283,285 Shd con together (B) (Pin 29, 30,31)		HSFPU	70	121100 P29	029	
-	-														
056	SPIRE SMEC PosPhDi#1FB(N) . S		SMK.-	-	S282	021SS-38	30				HSFPU	70	121100 P29	030	
055	SPIRE SMEC PosPhDi#1FB(N) . R		SMK.-	-	S282	021SS-38	30				HSFPU	70	121100 P29	031	
044	SPIRE SMEC PosPhDi#1FB(N) . SHD09		SMK.-	-	S282	021SS-38	30		Cable S282, 284,286 Shd con together (C) (Pin 44,45,46)		HSFPU	70	121100 P29	012	
-	-														
042	SPIRE SMEC PosPhDi#2(N) . I+		SMJ.-	-	S283	021SS-38	28				HSFPU	70	121100 P29	013	
041	SPIRE SMEC PosPhDi#2(N) . I-		SMJ.-	-	S283	021SS-38	28				HSFPU	70	121100 P29	014	
030	SPIRE SMEC PosPhDi#2(N) . SHD07		SMJ.-	-	S283	021SS-38	28		Cable S281, 283,285 Shd con together (B) (Pin 29,30,31)		HSFPU	70	121100 P29	032	
-	-														
034	SPIRE SMEC PosPhDi#2FB(N) . S		SMK.-	-	S284	021SS-38	31				HSFPU	70	121100 P29	033	
033	SPIRE SMEC PosPhDi#2FB(N) . R		SMK.-	-	S284	021SS-38	31				HSFPU	70	121100 P29	034	
045	SPIRE SMEC PosPhDi#2FB(N) . SHD10		SMK.-	-	S284	021SS-38	31		Cable S282, 284,286 Shd con together (C) (Pin 44,45,46)		HSFPU	70	121100 P29	015	
-	-														
020	SPIRE SMEC PosPhDi#3(N) . I+		SMJ.-	-	S285	021SS-38	29				HSFPU	70	121100 P29	016	
021	SPIRE SMEC PosPhDi#3(N) . I-		SMJ.-	-	S285	021SS-38	29				HSFPU	70	121100 P29	017	
031	SPIRE SMEC PosPhDi#3(N) . SHD08		SMJ.-	-	S285	021SS-38	29		Cable S281, 283,285 Shd con together (B) (Pin 29,30,31)		HSFPU	70	121100 P29	035	
-	-														
058	SPIRE SMEC PosPhDi#3FB(N) . S		SMK.-	-	S286	021SS-38	32				HSFPU	70	121100 P29	036	
057	SPIRE SMEC PosPhDi#3FB(N) . R		SMK.-	-	S286	021SS-38	32				HSFPU	70	121100 P29	037	

The pin allocations on the S/C 128-way connectors all match

This matches the I/F to the FCU

Pin Allocation List

(Harness)

Connector: 211121 P30**Function:** UFThr. 283.0° (SPIRE XS-11 FPU 25,27,29)**Conn.-Type:** 197-012P24-35S (Plug)**Item:** CVVUCR**Location:** 33 / CVV I/F CB Top PFM (CVVUCR)**Backshell:** G 9254 F 24 M**EMC-Category:** 2I/Sig H fr CVVFT to SVMCB

Pin	Signal Designation	Interface-Code			Ch. ID	Wiring	Grouping:			Comment	Target-Item	Location	Connector	Pin	New
		Circuit	Signal	Pos.			Shd	Cable	Twist						
-	-														
011	SPIRE SMEC PosSensPwr(N) . S		SMH.-	-	S280	021BS-38	26				HSSVMCB3	27	312300 J04	011	
004	SPIRE SMEC PosSensPwr(N) . R		SMH.-	-	S280	021BS-38	26				HSSVMCB3	27	312300 J04	004	
010	SPIRE SMEC PosSensPwr(N) . SHD05		SMH.-	-	S280	021BS-38	26			Cable S280 Shd	HSSVMCB3	27	312300 J04	010	
-	-														
018	SPIRE SMEC PosPhDi#1(N) . I+		SMJ.-	-	S281	021SS-38	27				HSSVMCB3	27	312300 J04	018	
019	SPIRE SMEC PosPhDi#1(N) . I-		SMJ.-	-	S281	021SS-38	27				HSSVMCB3	27	312300 J04	019	
029	SPIRE SMEC PosPhDi#1(N) . SHD06		SMJ.-	-	S281	021SS-38	27			Cable S281, 283,285 Shd con together (B)	HSSVMCB3	27	312300 J04	029	
-	-														
056	SPIRE SMEC PosPhDi#1FB(N) . S		SMK.-	-	S282	021SS-38	30				HSSVMCB3	27	312300 J04	056	
055	SPIRE SMEC PosPhDi#1FB(N) . R		SMK.-	-	S282	021SS-38	30				HSSVMCB3	27	312300 J04	055	
044	SPIRE SMEC PosPhDi#1FB(N) . SHD09		SMK.-	-	S282	021SS-38	30			Cable S282, 284,286 Shd con together (C)	HSSVMCB3	27	312300 J04	044	
-	-														
042	SPIRE SMEC PosPhDi#2(N) . I+		SMJ.-	-	S283	021SS-38	28				HSSVMCB3	27	312300 J04	042	
041	SPIRE SMEC PosPhDi#2(N) . I-		SMJ.-	-	S283	021SS-38	28				HSSVMCB3	27	312300 J04	041	
030	SPIRE SMEC PosPhDi#2(N) . SHD07		SMJ.-	-	S283	021SS-38	28			Cable S281, 283,285 Shd con together (B)	HSSVMCB3	27	312300 J04	030	
-	-														
034	SPIRE SMEC PosPhDi#2FB(N) . S		SMK.-	-	S284	021SS-38	31				HSSVMCB3	27	312300 J04	034	
033	SPIRE SMEC PosPhDi#2FB(N) . R		SMK.-	-	S284	021SS-38	31				HSSVMCB3	27	312300 J04	033	
045	SPIRE SMEC PosPhDi#2FB(N) . SHD10		SMK.-	-	S284	021SS-38	31			Cable S282, 284,286 Shd con together (C)	HSSVMCB3	27	312300 J04	045	
-	-														
020	SPIRE SMEC PosPhDi#3(N) . I+		SMJ.-	-	S285	021SS-38	29				HSSVMCB3	27	312300 J04	020	
021	SPIRE SMEC PosPhDi#3(N) . I-		SMJ.-	-	S285	021SS-38	29				HSSVMCB3	27	312300 J04	021	
031	SPIRE SMEC PosPhDi#3(N) . SHD08		SMJ.-	-	S285	021SS-38	29			Cable S281, 283,285 Shd con together (B)	HSSVMCB3	27	312300 J04	031	
-	-														
058	SPIRE SMEC PosPhDi#3FB(N) . S		SMK.-	-	S286	021SS-38	32				HSSVMCB3	27	312300 J04	058	
057	SPIRE SMEC PosPhDi#3FB(N) . R		SMK.-	-	S286	021SS-38	32				HSSVMCB3	27	312300 J04	057	

Pin Allocation List

(Harness)

Connector: 312300 J04

Function: SPIRE SVM CB3 (SPIRE Bundle 11)

Conn.-Type: MS27497T24-35P (Jun.Sh)

Item: HSSVMCB3

Location: 27 / I/F CB ab. SVM Panel 7 (SPI/CCU CB)

Backshell: 440 FS 110 M 24 03

EMC-Category: 2I/Sig H fr CVVFT to SVMCB

Pin	Signal Designation	Interface-Code			Ch. ID	Wiring	Grouping:			Comment	Target-Item	Location	Connector	Pin	New
		Circuit	Signal	Pos.			Shd	Cable	Twist						
-															
011	SPIRE SMEC PosSensPwr(N) . S		SMH.-	-	S280	021BS-38	26				CVVUCR	33	211121 P30	011	
004	SPIRE SMEC PosSensPwr(N) . R		SMH.-	-	S280	021BS-38	26				CVVUCR	33	211121 P30	004	
010	SPIRE SMEC PosSensPwr(N) . SHD05		SMH.-	-	S280	021BS-38	26		Cable S280 Shd		CVVUCR	33	211121 P30	010	
-															
018	SPIRE SMEC PosPhDi#1(N) . I+		SMJ.-	-	S281	021SS-38	27				CVVUCR	33	211121 P30	018	
019	SPIRE SMEC PosPhDi#1(N) . I-		SMJ.-	-	S281	021SS-38	27				CVVUCR	33	211121 P30	019	
029	SPIRE SMEC PosPhDi#1(N) . SHD06		SMJ.-	-	S281	021SS-38	27		Cable S281, 283,285 Shd con together (B)		CVVUCR	33	211121 P30	029	
-															
056	SPIRE SMEC PosPhDi#1FB(N) . S		SMK.-	-	S282	021SS-38	30				CVVUCR	33	211121 P30	056	
055	SPIRE SMEC PosPhDi#1FB(N) . R		SMK.-	-	S282	021SS-38	30				CVVUCR	33	211121 P30	055	
044	SPIRE SMEC PosPhDi#1FB(N) . SHD09		SMK.-	-	S282	021SS-38	30		Cable S282, 284,286 Shd con together (C)		CVVUCR	33	211121 P30	044	
-															
042	SPIRE SMEC PosPhDi#2(N) . I+		SMJ.-	-	S283	021SS-38	28				CVVUCR	33	211121 P30	042	
041	SPIRE SMEC PosPhDi#2(N) . I-		SMJ.-	-	S283	021SS-38	28				CVVUCR	33	211121 P30	041	
030	SPIRE SMEC PosPhDi#2(N) . SHD07		SMJ.-	-	S283	021SS-38	28		Cable S281, 283,285 Shd con together (B)		CVVUCR	33	211121 P30	030	
-															
034	SPIRE SMEC PosPhDi#2FB(N) . S		SMK.-	-	S284	021SS-38	31				CVVUCR	33	211121 P30	034	
033	SPIRE SMEC PosPhDi#2FB(N) . R		SMK.-	-	S284	021SS-38	31				CVVUCR	33	211121 P30	033	
045	SPIRE SMEC PosPhDi#2FB(N) . SHD10		SMK.-	-	S284	021SS-38	31		Cable S282, 284,286 Shd con together (C)		CVVUCR	33	211121 P30	045	
-															
020	SPIRE SMEC PosPhDi#3(N) . I+		SMJ.-	-	S285	021SS-38	29				CVVUCR	33	211121 P30	020	
021	SPIRE SMEC PosPhDi#3(N) . I-		SMJ.-	-	S285	021SS-38	29				CVVUCR	33	211121 P30	021	
031	SPIRE SMEC PosPhDi#3(N) . SHD08		SMJ.-	-	S285	021SS-38	29		Cable S281, 283,285 Shd con together (B)		CVVUCR	33	211121 P30	031	
-															
058	SPIRE SMEC PosPhDi#3FB(N) . S		SMK.-	-	S286	021SS-38	32				CVVUCR	33	211121 P30	058	
057	SPIRE SMEC PosPhDi#3FB(N) . R		SMK.-	-	S286	021SS-38	32				CVVUCR	33	211121 P30	057	

Pin Allocation List (Harness)

Connector: 211121 J32
Item: CVVUCR
EMC-Category: 2C/Sig H in Cryostat

Function: UFThr. 305.7° (SPIRE XS-01 JFS 5,6,9,10)
Location: 33 / CVV I/F CB Top PFM (CVVUCR)

Conn.-Type: 197-011P24-35P (Junct.)
Backshell: HERSKT 58-0050

Pin	Signal Designation	Interface-Code			Ch. ID	Wiring	Grouping:			Comment	Target-Item	Location	Connector	Pin	New
		Circuit	Signal	Pos.			Shd	Cable	Twist						
104	SPIRE SLW Bias A1 . SHD03		SSD.-	-	S025	022BS-38	25			Cable S025 inner Shd daisy ch to Pin 104 at CVV side (B3)	HSJFS	76	121220 P09	006	
-	Cable S025 outer Shield									Cable S025 outer Shd con to Busbar (Faraday)					
102	SPIRE SLW Bias A2 . +ve		SSD.-	-	S026	022BS-38	26				HSJFS	76	121220 P09	005	
101	SPIRE SLW Bias A2 . -ve		SSD.-	-	S026	022BS-38	26				HSJFS	76	121220 P09	024	
104	SPIRE SLW Bias A2 . SHD04		SSD.-	-	S026	022BS-38	26			Cable S026 inner Shd daisy ch to Pin 104 at CVV side (B3)	HSJFS	76	121220 P09	023	
-	Cable S026 outer Shield									Cable S026 outer Shd con to Busbar (Faraday)					
104	SPIRE SLW GND WIRE B3		SSX.-	-	S405	010B0-38				SLW GND Wire B3 con to cable 25,26,11,12 Shd	HSJFS	76	121220 P09	006	
092	SPIRE SLW JFETV A1 . +ve		SSF.-	-	S011	022BS-38	11				HSJFS				
091	SPIRE SLW JFETV A1 . -ve		SSF.-	-	S011	022BS-38	11				HSJFS				
104	SPIRE SLW JFETV A1 . SHD05		SSF.-	-	S011	022BS-38	11			Cable S011 inner Shd daisy ch to Pin 104 at CVV side (B3)	HSJFS				
-	Cable S011 outer Shield									Cable S011 outer Shd con to Busbar (Faraday)					
103	SPIRE SLW JFETV A2 . +ve		SSF.-	-	S012	022BS-38	12				HSJFS	76	121220 P09	008	
113	SPIRE SLW JFETV A2 . -ve		SSF.-	-	S012	022BS-38	12				HSJFS	76	121220 P09	027	
104	SPIRE SLW JFETV A2 . SHD06		SSF.-	-	S012	022BS-38	12			Cable S012 inner Shd daisy ch to Pin 104 at CVV side (B3)	HSJFS	76	121220 P09	026	
-	Cable S012 outer Shield									Cable S012 outer Shd con to Busbar (Faraday)					
090	SPIRE SSW Bias A1 . +ve		SSC.-	-	S029	022BS-38	29				HSJFS	76	121220 P09	028	
079	SPIRE SSW Bias A1 . -ve		SSC.-	-	S029	022BS-38	29				HSJFS	76	121220 P09	010	
093	SPIRE SSW Bias A1 . SHD07		SSC.-	-	S029	022BS-38	29			Cable S029 inner Shd daisy ch to Pin 093 at CVV side (C3)	HSJFS	76	121220 P09	009	
-	Cable S029 outer Shield									Cable S029 outer Shd con to Busbar (Faraday)					
068	SPIRE SSW JFETV A1 . +ve		SSE.-	-	S016	022BS-38	16				HSJFS	76	121220 P09	011	
057	SPIRE SSW JFETV A1 . -ve		SSE.-	-	S016	022BS-38	16				HSJFS	76	121220 P09	030	

This is compliant with SPIRE HDD 1.2

