



HERSCHEL TELESCOPE SPECIFICATION

Prepared by: D. de Chambure
ESA Herschel/Planck Telescope Engineer

Approved by: G. Crone
ESA Herschel/Planck Payload Manager

T. Paßvogel
ESA Herschel/Planck Project Manager

ESA Herschel/Planck Project

reference: SCI-PT-RS-04671

issue: 6

revision: 0

date of issue: 22 October 2002

ESTEC

Postbus 299 - NL 2200 AG Noordwijk - Keplerlaan 1 - NL 2201 AZ Noordwijk ZH - The Netherlands

Tel (31) 71 565 3473 - Fax (31) 71 565 5244 - <http://sci.esa.int/herschel> --
<http://sci.esa.int/planck>



Herschel/Planck

Herschel Telescope Specification

Reference: SCI-PT-RS-04671

Date: 22 October 2002

Issue/Rev. No: 6/0

page: ii

DOCUMENT CHANGE RECORD

Issue / Rev. Date	Pages affected / Brief description of change
November 1997	F. Felici, FIRST/Planck Project Manager (Acting) ESA/ESTEC, Noordwijk
1/A January 1998	All changes on pages listed below are indicated by bold vertical lines in the left hand margins. i, iii, 1-1, 2-1, 2-2, 2-3, 3-3, 3-4, 4-1, 4-3, 4-5, 4-6, 5-1, 5-2, 5-6, 5-7, 5-9, 5-10, 5-11, B-2, B-3, B-4, B-5, B-6, B-7
2/0 July 1999	New issue of document. All changes on pages listed below are indicated by bold vertical lines in the left-hand margins. Changes after FIRST telescope workshop held at ESTEC on 21-22 July 1999.
3/0 May 2000	All changes on pages listed below are indicated by a vertical line in the left margin. i, v, 7, 10, 12, 15, 19, 33
4/0 11 May 2001	New issue of document for start of the Herschel telescope contract based on SiC technology. All changes on pages listed below are indicated by vertical lines in the left-hand margins. Par 6.4 Deliverables has been deleted (i.e. part of SoW).
5/0 5 April 2002	Update of document following start of the Herschel telescope contract followed by the Mid Term Review (MTR) in view of the Critical Design Review (CDR). All changes are indicated by vertical lines in the left-hand margins.
6/0 22 October 2002	Update of document following successful Critical Design Review (CDR) and following negotiation meeting on Herschel telescope contract in September 2002. The following requirements TEFU-010, TEFU-015, TEFU-070, TEFU-080, TEPE-065, TEPE-075, TEPE-090, TEEN-090, TEVE-050, TEVE-055, TEEN-030, section 3.3, the figure 4.3.1 and the annex-B have been modified. Requirement TEFU-095 on protective cover has been added for clarification.

DISTRIBUTION LIST

COMPANY	NAME	DIVISION	No. of COPIES
Alcatel	Juillet, J.J.	Cannes - F	1
	Reix, J.M.		1
	Rideau, P.		1
	Martin, P.		1
	Clavel P.		1
Astrium – F	Castel, D.	Toulouse - F	1
	Peyrou-Lauga R.		1
	Pierot, D		1
	Rivière R.		1
	Safa, F.		1
	Toulemont, Y		1
	Varin. JL		1
Astrium – D	Hoelzle, E.	Friedrichshafen - D	1
	Ruehe, W		1
ESA/ESTEC	Boisard, N.	IMT-CTP	1
	Crone, G.	SCI-PT	1
	Doyle, D.	TOS-MMO	1
	Estaria, P.	SCI-PT	1
	Gonzalez, G.	SCI-PT	1
	Guillaume, B.	SCI-PT	1
	Heske, A	SCI-PT	1
	Hoegen, M. von	SCI-PTQ	1
	Kirchner, V.	TOS-MMO	1
	Olivier, P	SCI-PTQ	1
	Paßvogel, T.	SCI-PT	1
	Pilbratt, G.	SCI-SA	1
	Smith, M.	IMT-CTP	1
	Stolfi, E.	SCI-PT	1
			1
Herschel/Planck project	SCI-PT	1	

TABLE OF CONTENTS

1	INTRODUCTION	1
2	SCOPE	2
2.1	Terms and Acronyms	2
2.2	Abbreviation List for Requirements	3
2.3	Documents	3
2.3.1	Applicable Documents (AD)	3
2.3.2	Reference Documents (RD)	4
3	3 GENERAL REQUIREMENTS	4
3.1	Description of Herschel Telescope	4
3.2	General Functional Requirements of the Telescope	4
3.3	Axis System of the Telescope	4
3.4	Optical Axis System of the Telescope	5
3.5	General Interface Requirements	5
3.5.1	Mechanical	5
3.5.2	Thermal	6
3.5.2.1	Thermal Interface with Sunshield/Sunshade	6
3.5.2.2	Thermal Interface with PLM	6
3.5.2.3	Thermal Gradients	6
3.5.3	Electrical	7
3.5.4	Interface with Spacecraft Sunshield	8
3.5.5	GSE Interfaces	11
4	MISSION AND PERFORMANCE REQUIREMENTS of the TELESCOPE	12
4.1	General Specifications for the Telescope	12
4.1.1	Telescope	12
4.1.2	Heaters	12
4.2	Optical Requirements	14
4.2.1	Telescope Performances	14
4.2.2	Straylight	16
4.2.3	Coating	17
4.3	Physical Requirements	17
4.3.1	Dimensions of the Telescope	17
4.3.2	Mass properties	17
4.3.3	Alignment	18
5	ENVIRONMENTAL, LIFETIME, DESIGN and CONSTRUCTION REQUIREMENTS	20
5.1	Lifetime, Storage and Transport	20
5.1.1	Lifetime	20
5.1.2	Storage Environment	20
5.1.3	Transportability and Handling	20
5.2	Pressure - Humidity	21
5.2.1	Pressure	21
5.2.2	Humidity	21
5.3	Radiation	21
5.4	Cleanliness/Cleanability	21
5.5	Thermal environment	23
5.5.1	Temperatures of the Telescope	23
5.5.2	Thermal Shock/Thermal Cycling - Bake-Out	23
5.6	Design and Construction Requirements	24

5.6.1	Mechanical Stiffness Requirements	24
5.6.2	Design Limit loads	24
5.6.3	Mechanical Strength Requirements	25
5.6.3.1	Safety Factors	25
5.6.3.2	Margins of Safety	25
5.6.4	Mechanical Interface Points characteristics	26
5.6.5	Sinusoidal Vibrations of the Telescope	29
5.6.5.1	Sinusoidal Test Levels	29
5.6.6	Acoustic Vibrations of the Telescope	29
5.7	Interchangeability	30
5.8	Maintenance	30
5.9	Reliability	30
5.10	Parts, Material and Processes	31
5.10.1	General	31
5.10.2	Dissimilar Metals	31
5.10.3	Magnetic Materials	31
5.10.4	Fungus Nutrient Materials	31
5.10.5	Unstable Materials	31
5.10.6	Mechanical Parts	31
5.10.7	Finish	31
5.10.8	Outgassing	32
5.10.9	Cleanliness/Contamination Control	32
5.10.10	Susceptibility to Stress Corrosion	32
5.10.11	Material brittleness	32
5.10.12	Grinding and polishing processes	33
5.11	EMC Requirements	33
5.12	Identification and Marking	33
5.13	Workmanship	33
5.14	Refurbishment	34
5.15	Facilities	34
6	VERIFICATION REQUIREMENTS	35
6.1	Verification Methods, Programmes and Matrices	35
6.1.1	Verification Programme	35
6.1.2	Verification by tests and samples	35
6.2	Analysis, Inspection and Test	36
6.3	Telescope Verification Testing	36
6.3.1	Mechanical Verification Testing of the Telescope	36
6.3.2	Thermal Verification Testing of the Telescope	36
ANNEX A: WFE TREE BUDGET VERIFICATION		1
ANNEX B: TEST SEQUENCE		2

1 INTRODUCTION

ESA's Horizon 2000 Science Programme has two important missions for performing astronomical investigations in the far-infrared, sub-millimetre and millimetre wavelength range:

- **Herschel** (previously called FIRST, the Far Infrared and Sub-millimetre Telescope), an observatory type mission;
- Planck (previously named COBRAS/SAMBA), a survey mission.

Herschel is the fourth "cornerstone" (CS4) mission in the European Space Agency (ESA) long term space science plan "Horizons 2000". **Herschel** is a multi-user (observatory type) mission, which targets the far-infrared and sub-millimetre part of the spectrum. **Herschel** will address key scientific topics such as deep broadband extra-galactic surveys, follow-up spectroscopy of especially interesting program objects discovered in the survey, detailed studies of the physics and chemistry of the interstellar medium in galaxies, including star formation, observational astro chemistry of gas and dust and detailed high-resolution spectroscopy of a number of comets.

Herschel will operate in the spectral range between 80 and 670 μm wavelength. The operational orbit shall be assumed to be an orbit around the second Libration point (L_2) in the Earth/Moon - Sun system at an average distance of 1.5 million kilometres from the Earth.

The concept for the **Herschel** telescope is based on an axisymmetric, 3.5-m-diameter Cassegrain design. The telescope is protected by a sunshield in order to avoid direct solar radiation to the primary and secondary reflectors and their structures and to provide a stable thermal environment, which minimises temperature variations across the telescope.

Due to the science requirements, high initial accuracy and in-orbit thermal stability are required by the telescope to enable spectroscopy and photometry in the far infrared and submillimetre frequency range.

2 SCOPE

This specification establishes the performances, design, development and qualification test requirements for the Herschel telescope.

2.1 Terms and Acronyms

AD	Applicable Document
AIV	Assembly, Integration & Verification
BOL	Begin of Life
CFRP	Carbon Fibre Reinforced Resin
CTE	Coefficient of Thermal Expansion
EOL	End of Life
EP	Entrance Pupil
FIRST	Far Infrared and Submillimetre Telescope
FOV	Field-of-view
LOS	Line Of Sight
MGSE	Mechanical Ground Support Equipment
MOS	Margin of Safety
N/A	Not applicable
NDI	Non Destructive Inspection
OGSE	Optical Ground Support Equipment
PA	Product Assurance
PLM	Payload Module
PSF	Point-Spread-Function
RD	Reference Document
RH	Relative Humidity
RMS	Root Mean Square
S/C	Spacecraft
TBC	To be confirmed
TBD	To be determined

WFE

Wave Front Error

2.2 Abbreviation List for Requirements

The requirements in this specification have been systematically numbered. The code applied consists of four letters and three digits. The four letters start for the telescope with TE, continued with an abbreviation of the area concerned. The numbering convention is illustrated in the table below.

<i>Requirement Type</i>	<i>Abbreviation</i>	<i>Specification paragraph</i>
<i>Functional and General Requirements</i>	<i>TEFU-xxx</i>	3.
<i>Mission and Performance</i>	<i>TEPE-xxx</i>	4.
<i>Environmental, Design and Construction</i>	<i>TEEN-xxx</i>	5.
<i>Verification</i>	<i>TEVE-xxx</i>	6.

2.3 Documents

The following documents of the exact issue shown form a part of this specification. In the event of conflict between documents referenced herein and the content of the specification, the content of this specification shall be considered a superseding requirement.

2.3.1 Applicable Documents (AD)

The following documents form a part of this specification.

<u>Ref</u>	<u>Reference</u>	<u>Issue - date</u>	<u>Title</u>
1.	ESTEC/WMA/he/ FIRST/3	4 - Mar 97	FIRST L ₂ Radiation Environment
2.	ECSS-Q-70-01A - Draft	18 June 99	Cleanliness and contamination control
3.	ECSS-Q-70A	Apr 96	Materials, Mechanical Parts and Processes
4.	ESA PSS-01-702	2 - Oct 94	A thermal vacuum test for the screening of space materials
5.	SCI-PT-RS-04683	2-rev1 20 Sep 00	Product Assurance Requirements for FIRST/Planck Satellite
6.	ECSS-Q-70-36A	20 Jan 98	Material selection for controlling stress corrosion cracking
7.	PT-RQ-09060, Is 1	10/05/01	Durability requirement for Herschel optical coating
8.	ARIANESPACE	3/0 - March 00	ARIANE 5 Users Manual
9.	ESA PSS-01-301	2 - Apr 92	Derating requirements applicable to electronic, electrical and electro-mechanical equipment
10.	SCI-PT-RS-05991	latest issue	System Requirements Specification

2.3.2 Reference Documents (RD)

The Telescope Provider is invited to refer to the following documents for guidance.

<u>Nb</u>	<u>Reference</u>	<u>Issue - date</u>	<u>Title</u>
1.	PSS-03-203	1 - Feb. 94	Structural Materials Handbook Vol. 1 and 2
2.	CSG-RS-10A-CN & 22A-CN	5/1	CSG Safety Regulations, Vol 1 & Vol 2, Part 2
3.	HP-2-ASED-TN-002	Draft July 01	Herschel Alignment Concept

3 GENERAL REQUIREMENTS

3.1 Description of Herschel Telescope

The Telescope is composed of:

- a primary reflector,
- a secondary reflector,
- a secondary reflector support structure (tripods, bipods, hexapod or else)
- a telescope support structure (3 bipods)
- baffles as necessary
- thermal hardware (MLI or thermal screens; heaters; harness, thermistors..) for in-orbit contamination release from optical surfaces and for bake-out of the telescope
- telescope adjustment shims
- Alignment devices (cubes, pin balls).

The telescope interfaces with the PLM interface frame , which is part of the Payload Module (PLM). The telescope and the PLM shall be thermally decoupled to the maximum extent.

3.2 General Functional Requirements of the Telescope

TEFU-005 The telescope primary reflector shall collect the electromagnetic radiation and shall deliver the collected power via the secondary reflector to the focal plane units.

The sunshield of the spacecraft will provide a stable thermal environment to the telescope and will therefore protect the telescope from direct Sun irradiation during all operation phases and modes and will provide for overall straylight reduction.

3.3 Axis System of the Telescope

The following axis system shall be used for the telescope: the basic coordinate system shall be a right handed Cartesian system with its origin located within the plane defined by the mean plane passing through the center of the 3 bipods interface zones (including telescope adjustment shims foreseen to be between 2 and 12 mm thick), at the centre of the triangle defined by the three interface zones.

The X-axis is perpendicular to this interface plane, positive towards the target source. The Z-axis is in the plane normal to the X-axis such that nominally the Sun will lie in the XZ-plane (zero roll axis with respect to the Sun), positive towards the Sun.

The Y- axis completes the right-handed orthogonal reference frame.

3.4 Optical Axis System of the Telescope

TEFU-007 The telescope optical axis is by definition the axis going through the vertices of the Primary and Secondary mirrors. The optical axis shall coincide with the axis normal to the telescope interface plane (defined in par 3.5.1) and shall pass through the geometrical centre of this plane. The coincidence between the 2 axes shall be within a halfcone angle of 3 mrad. The deviation shall be verified with an accuracy better than 2 mrad at ambient (measurement) and in vacuum (measurement and analysis).

3.5 General Interface Requirements

The figure 3.5-1 summarises the different interfaces with the telescope.

All dimensional parameters are defined w.r.t. a reference plane at the height of the instrument optical bench.

3.5.1 Mechanical

TEFU-010 The telescope interfaces mechanically with the PLM frame via three interface areas (defined in TEEN-130), which shall allow alignment and mounting of the complete telescope to the PLM. The telescope includes axial adjustment shims under their bipods. The thickness of the shims under the bipod is between 2 and 12 mm.

TEFU-015 One interface point shall be located on the -Z-axis, at a distance of 875 mm from the X-axis. The other interface points shall be within the Y/Z Plane and be at +/- 120 degree rotated around the X-axis..

TEFU-020 The structural interface of the telescope and its accessibility shall allow an easy and reproducible assembly and alignment of the complete telescope to the PLM.

TEFU-025 The surface planarity across the three telescope flight mounting areas shall be better than 20 μ m) peak to valley when considering the mean plane through the mountings as reference. The roughness

of each mounting area shall be better than 3.2 μm (rms). The Flight mounting areas of the telescope shall be protected during transportation and AIV activities when not integrated.

3.5.2 Thermal

3.5.2.1 Thermal Interface with Sunshield/Sunshade

The thermal interface between the telescope and the sunshield/sunshade is a radiative coupling.

TEFU-030 The sunshield/sunshade interface temperatures to be considered for the thermal interface with the telescope are given in figure 3.5-2.

TEFU-035 The sunshield/sunshade surface properties shall be used as defined in figures 3-5.2-a and b.

3.5.2.2 Thermal Interface with PLM

The thermal interface between the telescope and the PLM is a radiative and conductive coupling.

TEFU-040 The PLM interface temperatures to be considered for the thermal interface with the telescope are given in figure 3.5-2.

TEFU-045 The PLM surface properties shall be used as in figure 3-5.2.

TEFU-050 The telescope is conductively coupled to the PLM via the PLM interface frame. This conductively coupled interface shall be considered for the telescope design with a total conductance value of 9 mW/K at 75K, and 44mW/K at 300K.

3.5.2.3 Thermal Gradients

TEFU-055 The maximum values for the thermal gradients across the primary reflector of telescope are the following:

- Gradient in Z-direction: 10 K*
- Gradient in Y-direction: 1 K*
- Gradient change in Z-direction: 13 mK/min*
- Gradient change in Y-direction: 1.3 mK/min.*

3.5.3 Electrical

TEFU-060 All telescope conductive surfaces, as well as the mirror coatings shall be grounded. All thermal blankets larger than 100 cm² shall be grounded on the telescope.

TEFU-065 The electrical resistance between any grounding point of the telescope and the telescope grounding system (on S/C side) shall be less than 1Ω.

TEFU-070 Provision shall be made for heaters and thermal sensors on the telescope (reflectors; tripod; thermal H/W; etc..).

The following configuration shall be adapted for the heater lines of the telescope:

- 7 nominal lines of 85W each under 23,8V at the telescope connector on M1*
- 2 nominal lines of 21.5W each under 25,8V at the telescope connector on M2.*

The heater maximum voltage at telescope interface is respectively 24.9 V for the 85 W lines and 26.9V for the 21.5 W lines.

In case of failure of one nominal line, the other lines should be able to maintain the temperature. The lines on M1 and M2 will be independently controlled using the median temperature of 3 selected thermistors and by an ON/OFF switching of all lines with high/low thresholds.

A maximum of 12 thermistor lines (12 on M1 and 3 on M2) are foreseen for the telescope temperature during decontamination and during orbital life.

TEFU-075 The telescope shall provide:

- fixation points for the Herschel S/C heater and thermal sensor harnesses and*
- connectors for interfacing with the Herschel S/C thermal control system*
- dedicated points for the thermal blanket grounding (i.e. M5 threaded holes for instance).*

Type and location of fixation points and connectors are TBD.

TEFU-080 For decontamination release, the thermal design of the telescope shall permit to achieve in-orbit temperature as defined in TEPE-040 when a power of maximum 600 W under the maximum voltage defined in TEFU-070 (at telescope interface) is dissipated in the telescope heaters.

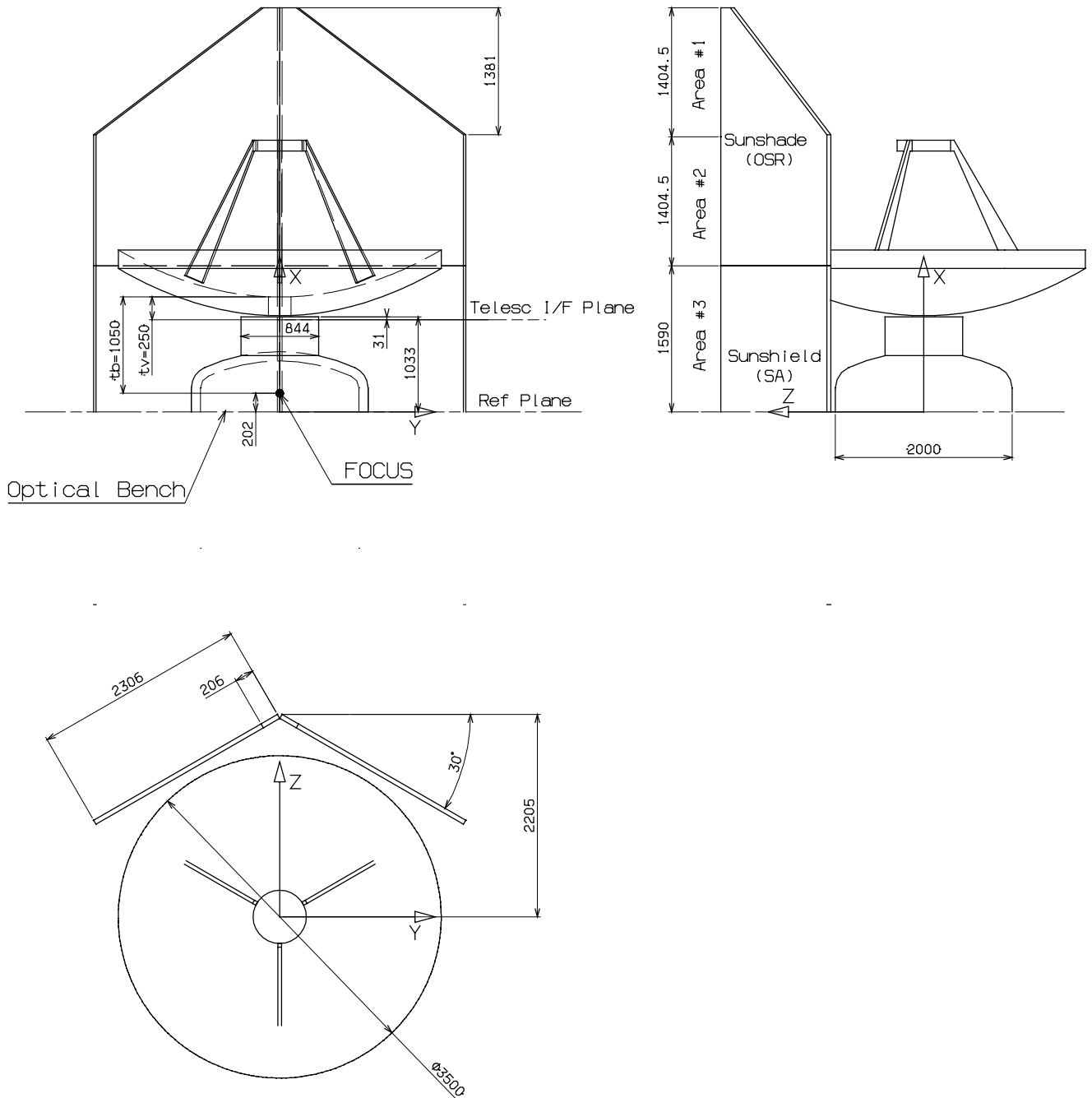
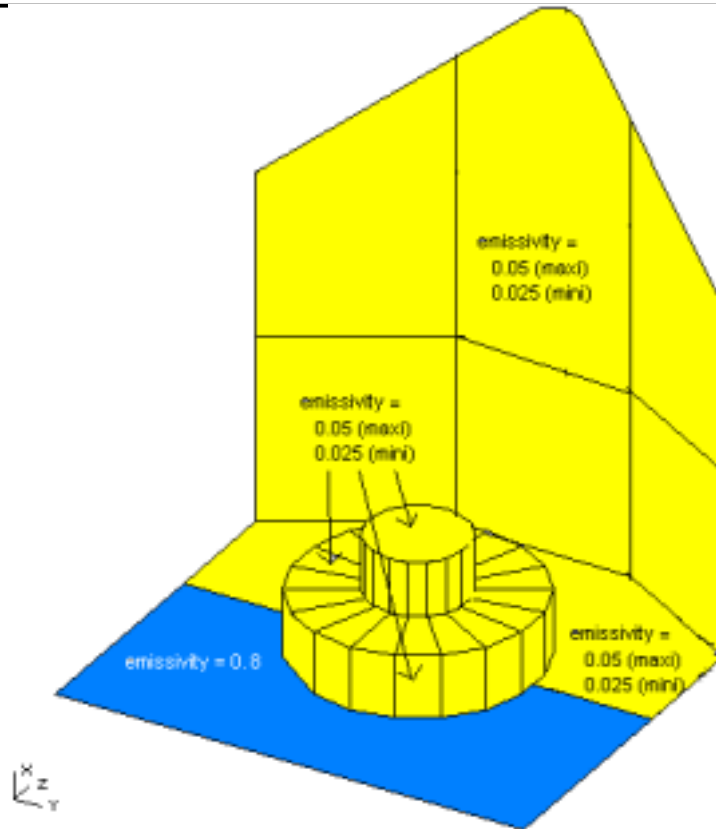

Figure 3.5-1-b: Mechanical Interface Telescope/PLM
(dimensions of sunshade/sunshade not correct – see fig 3-5-1-a)



INCORPORER Figure 3.5-2/a: Thermal Interfaces (emissivities)

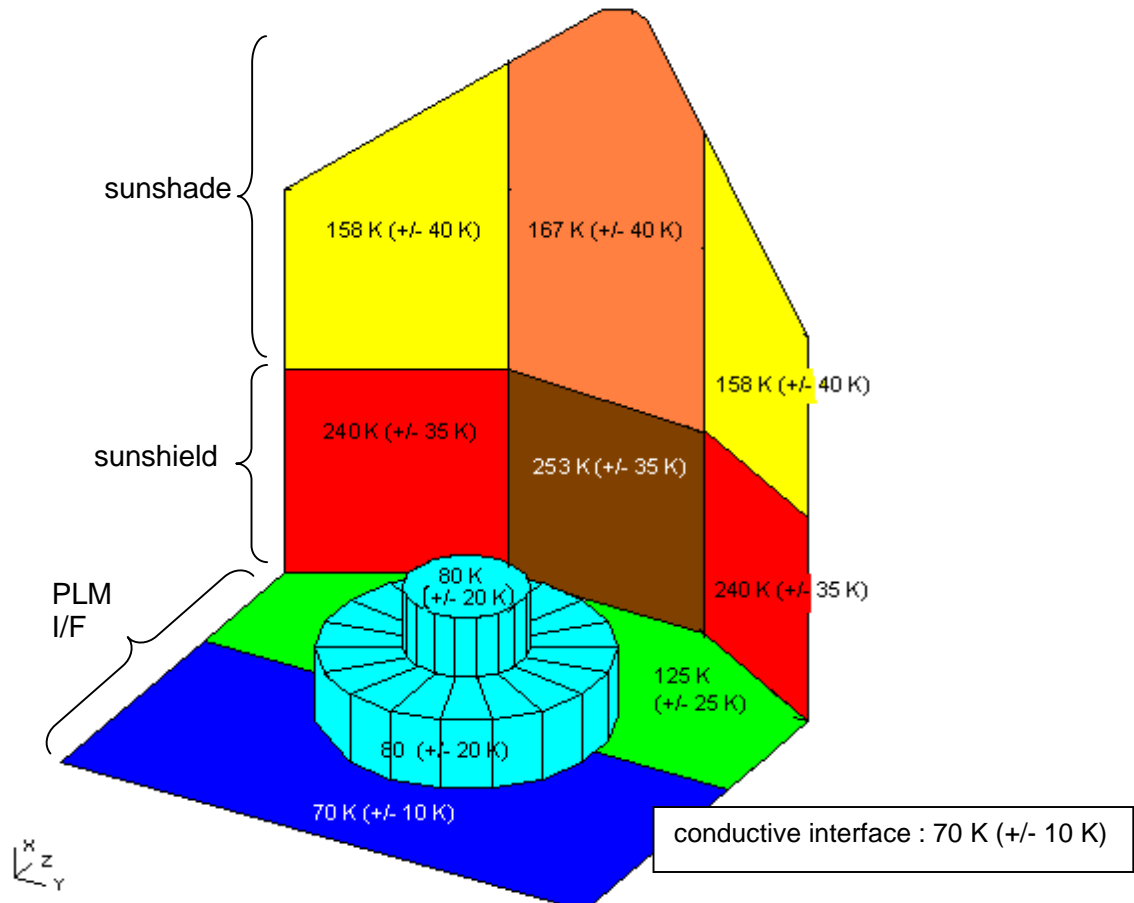

Figure 3.5-2/b: Thermal Interfaces (temperatures)

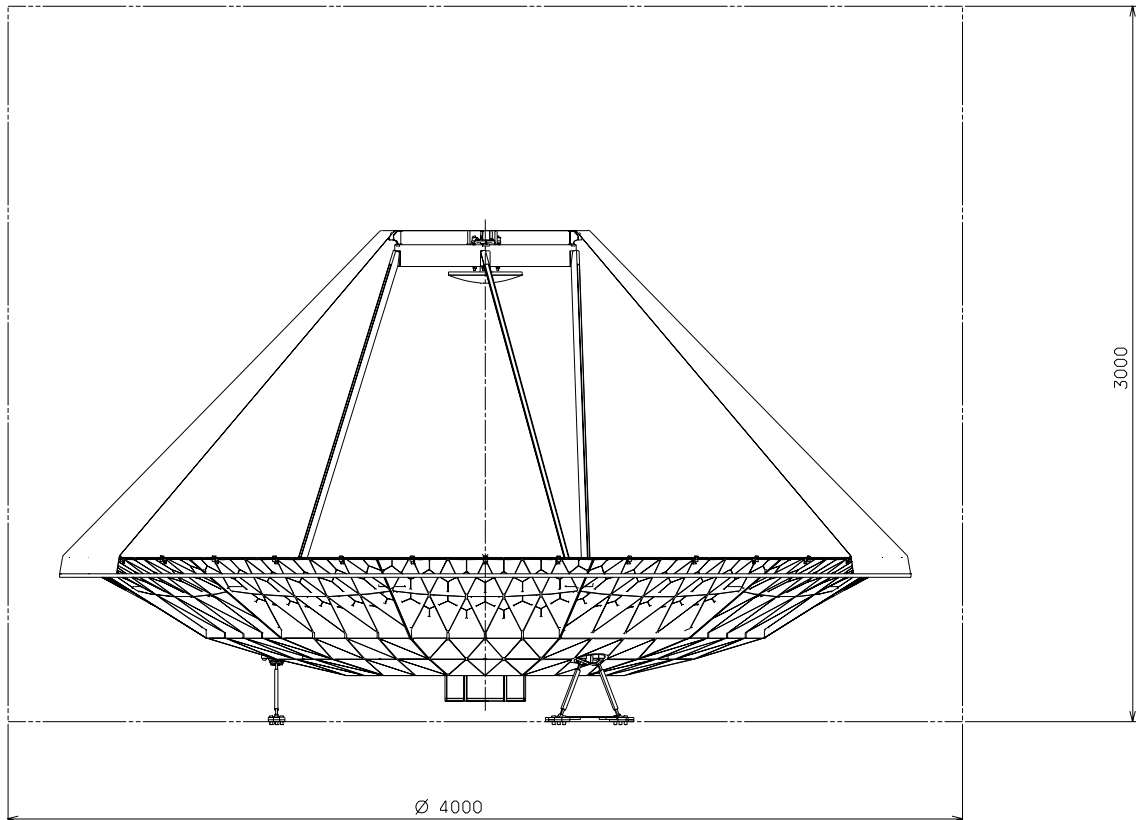

Figure 3.5-3: telescope hoisting device envelope (delimited by a cylinder $\text{Ø}4000$, height 3000)

3.5.5 GSE Interfaces

- TEFU-085** *The max. height for hoisting device shall not exceed 3 meter (from bottom telescope I/F to crane hook) with a volume not exceeding that given in fig (3.5-3).*
- TEFU-090** *The telescope and especially the primary mirror shall be equipped with handling interface points for hoisting in all AIT sequences from manufacturing until integration on Herschel S/C (assumed to be in vertical position).*
- TEFU-095** *The telescope shall be equipped with a protective cover having the function to protect the telescope from particulate contamination in all*

AIT activities (incl vibration and acoustic tests with the exception of the thermal vacuum tests) until launcher fairing installation.

4 MISSION AND PERFORMANCE REQUIREMENTS of the TELESCOPE

4.1 General Specifications for the Telescope

4.1.1 Telescope

The general configuration of the telescope is shown in Figure 4.1-1.
The telescope shall comply with the following specifications:

- TEPE-005** *The average telescope temperature shall be within a temperature range of 70 K or lower (*) up to 90 K.
This is called the **Performance Temperature Range**.
(*) the telescope design shall withstand with margins a temperature above 55K (ref TEEN.075)*
- TEPE-010** *The telescope shall be designed to meet its performance within the Performance Temperature Range.*
- TEPE-015** *The optical free diameter of the Primary Reflector shall be 3,500 mm +2mm, - 0 mm.*
- TEPE-020** *The f-number of the Primary Reflector shall be 0.5*
- TEPE-025** *The area obscuration ratio including:*
- secondary reflector structure (tripod; hexapod or else) with secondary reflector and its shadowing
- "cone in secondary"
shall be: ≤ 0.077 (with respect to the paraxial entrance pupil).
- TEPE-030** *The nominal distance of the primary reflector vertex-best on axis focus shall be*
- by construction value $t_b = 1,050$ mm
- this value shall be measured with the accuracy defined in TEPE-0150.
- TEPE-035** *The nominal distance of the best focus to the telescope fixation plane (including telescope shims and excluding PLM possible shims) shall be: $t_f = 800$ mm with the accuracy defined in TEPE-0150 (see Figure 4.1-1).*

4.1.2 Heaters

The telescope shall be designed to allow the decontamination/ contamination prevention of the optical surfaces in the early orbital phase by means of heaters.

TEPE-040 The heaters shall allow an increase of the orbital average

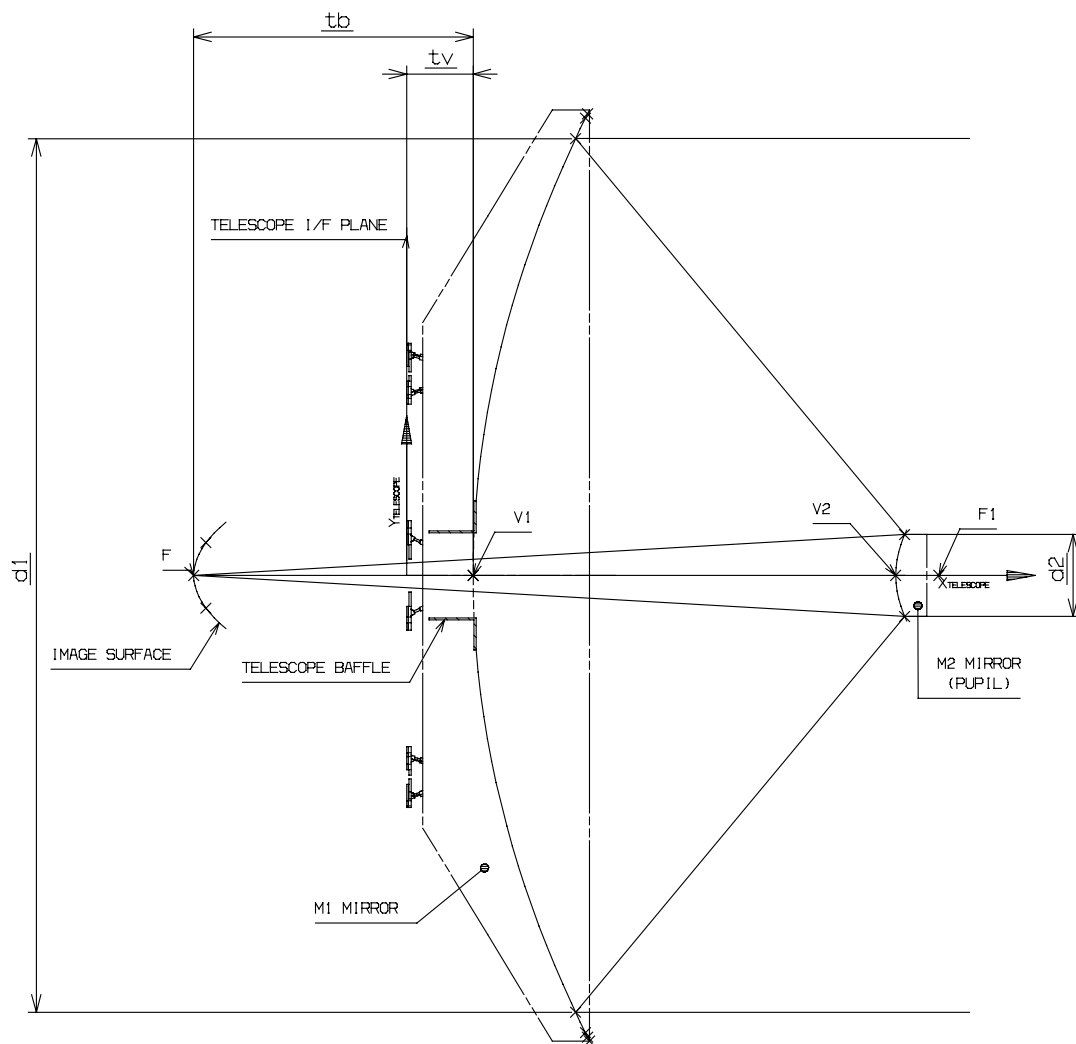

temperature of the telescope to a contamination release temperature, of at least 313 K and shall be able to maintain this temperature for a minimum duration of 3 weeks in a row.

Figure 4.1-1 TELESCOPE CONFIGURATION

4.2 Optical Requirements

4.2.1 Telescope Performances

The telescope shall comply with the following optical performance requirements until the end of its life when in temperature performance range:

TEPE-045 Operating wavelength range 80 μm to 670 μm .

TEPE-050 Telescope total WFE Budget at nominal focus $\leq 6.0 \mu\text{m rms}$

These performances shall be met within the performance temperature range for the complete FOV.

TEPE 055 Encircled Energy

The encircled energy shall be better than the values given in table 4.2.1-1 , respectively at 85 μm and 150 μm .

Performance at 85 μm

Encircled energy	50%	0,52 mm
	60%	0,72 mm
	70%	1,24 mm
	80%	2,17 mm

Spot radius (mm)	4	85,8% of energy
	7	90,4% of energy
	11	93,2% of energy
	15	95,2% of energy

Performance at 150 μm

Encircled energy	50%	0,80 mm
	60%	0,97 mm
	70%	1,75 mm
	80%	2,44 mm

Spot radius (mm)	7	89,0% of energy
	12	92,3% of energy
	19	94,3% of energy
	26	95,7% of energy

Table 4.2.1-1 encircled energy performance (tbc)

Nota: modelization accuracy on encircled energy is estimated to be $\pm 0,3\%$

TEPE-060 The aperture stop location shall be implemented at the secondary reflector.

TEPE-065 The system focal length shall be $28.5 \text{ m} \pm 0,15 \text{ m}$ and the f-number of the telescope shall be $f/D = 8.68$ (precision ± 0.02) where D is the diameter of the effective aperture (i.e. entrance pupil).

TEPE-070 The Field-of-view (FOV) shall be $\pm 0.25^\circ$, free of vignetting.

TEPE-075 The optical characteristics of the Primary and Secondary reflectors with their tolerances are given in the table below:

Primary reflector		
Radius of curvature	3500 mm	$\pm 2 \text{ mm} (*)$
Conic constant	-1	
f-number	$f/0.5$	
(Free) diameter	3500 mm	$0, +2 \text{ mm} (*)$
Secondary reflector		
Radius of curvature	345.2 mm	$\pm 0.4 \text{ mm} (*)$
Conic constant	-1.279	
Diameter	308.1 mm	$\pm 0.5 \text{ mm}$
Image surface		
Radius of curvature	- 165 mm	
Conic constant	-1	
Diameter	246 mm	

(*) Tolerances given as indications: Compensation between some parameters is assumed allowed if requested, provided that the telescope optical parameters are preserved (f-number, focal length, focus position).

TEPE-080 The telescope shall maintain the specified performance over its lifetime without the need for a refocusing mechanism.

TEPE-085 The telescope design shall be such as to avoid narcissus effect.

TEPE-090 Relative spectral transmission^a $\geq 0.975 \text{ BOL}^b$
 $\geq 0.98 \text{ BOL}$ (goal)^b

The in-orbit degradation shall be less than 0.005.

This shall be demonstrated

- at any wavelength λ within the operating range measured on witness samples over a sampling interval of $\Delta\lambda/\lambda = 1/100$
- and by analysis over the entire FOV.

TEPE-095 Non-uniformity of relative spectral transmission^d $\leq \pm 0.01$.

Notes and definitions for TEPE-090 and 095:

- a. The relative spectral transmission $\tau(\lambda)$ of the telescope is defined by

$$\tau(\lambda) = \phi(\lambda) / \phi_o(\lambda)$$

with

$\phi(\lambda)$ integrated flux [W] leaving the telescope in image space

$\phi_o(\lambda)$ integrated flux [W] entering the telescope through its entrance pupil within the unobstructed areas.

- b. At acceptance and delivery of the telescope.
- c. The design life is specified in paragraph 5.1
- d. The non-uniformity of the relative spectral transmission is defined as the maximum deviation between the relative spectral transmission values for any 100 mm diameter area within the entrance pupil (EP) and the average relative spectral transmission determined for the full EP area of the telescope, excluding the gaps between the segments.

4.2.2 Straylight

The Straylight requirement for the telescope including the sunshield, is defined w.r.t. the straylight level obtained at a specified detector element location. The definition of the optical components and properties between the Primary reflector and the detector element, as far as relevant for the straylight verification is called the **PLM/Focal Plane Unit Straylight model** and will be provided by ESA.

The following straylight requirements apply over the full operational wavelength range:

- Scattered light

TEPE-100 Sources outside telescope FOV:

Taking into account the worst combination of the Moon and the Earth positions w.r.t. the LOS of the telescope with maximal:

- Sun - S/C - Earth angle of 37°
- Sun - S/C - Moon angle of 47°
- Sun - S/C - LOS angle of 60° to 120°,

the straylight shall be: < 1.0% of background radiation induced by self-emission of the telescope.

TEPE-105 Sources inside FOV:

over the entire FOV at angular distances $\geq 3'$ from the peak of the point-spread-function (PSF), the straylight shall be:

< $1 \cdot 10^{-4}$ of PSF peak irradiance (in addition to level given by diffraction).

- Self-emission

TEPE-110 The straylight level, received at the defined detector element location of the PLM/Focal Plane Unit Straylight model by self emission (with "cold" stops in front of PACS and SPIRE instrument detectors), not including the self emission of the telescope reflectors alone, shall be $\leq 10\%$ (tbc) of the background induced by self-emission of the telescope reflectors.

4.2.3 Coating

The optical coating of the telescope reflectors shall be designed for the operating wavelength defined in 4.2.1.

TEPE-115 The coating shall comply with the durability requirements defined in AD-7.

TEPE-120 The durability requirements of the optical coating shall be verified with representative samples from the same coating batch/material as the reflectors.

TEPE-125 The optical coating shall be grounded via the telescope grounding system.

4.3 Physical Requirements

4.3.1 Dimensions of the Telescope

TEPE-130 The telescope and its interfaces shall not exceed the size of the dynamic envelope defined in Figure 4.3-1.

4.3.2 Mass properties

TEPE-135 The total mass of the Telescope (including the thermal H/W and the alignment cubes) shall not exceed 300 kg.

TEPE-140 The knowledge accuracy of the position of the centre of gravity (CoG) shall be better than ± 3 mm: it shall be verified by test (Y and Z axes) and by analysis (X axis). The knowledge accuracy of the moments of inertia wrt CoG shall be better than $\pm 5\%$ (analysis).

4.3.3 Alignment

- TEPE-145 The telescope shall be equipped with optical alignment references (cube and pinball) for the purpose of PLM-telescope alignment. These alignment references shall represent an orthogonal telescope reference frame.*
- TEPE-150 The actual on-axis point of the best focus shall be positioned and located within a cylindrical tolerance volume perpendicular and centred on the X-axis of the telescope. The volume of the cylinder shall be ± 5 mm (with a goal of 3 mm) in cylinder-axis (X-direction) and ± 5 mm (with a goal of 3 mm) in diameter.*
- TEPE-155 The centre of the telescope field of view in the focal plane shall be known with respect to this reference frame with an accuracy of ± 3.5 mm in lateral direction and ± 3 mm (defocus) in axial direction (with a goal of ± 2 mm).*
- TEPE-160 The secondary reflector shall be positioned with a lateral accuracy of ± 3 mm (with a goal of 2 mm) with respect to this reference frame and its position shall be known with an accuracy of ± 1 mm (with a goal of 0.5 mm).*
- TEPE-165 The alignment references shall be visible also after completion of integration of the telescope with the PLM.*

5 ENVIRONMENTAL, LIFETIME, DESIGN and CONSTRUCTION REQUIREMENTS

5.1 Lifetime, Storage and Transport

5.1.1 Lifetime

TEEN-005 The design life of the Herschel telescope shall be at least 4 years of on-ground operations (testing, transport and launch preparation including the storage conditions) followed by 4.5 years of in-orbit operations with no performance degradation to a level inferior to that given in this specification.

5.1.2 Storage Environment

TEEN-010 The storage conditions and storage environment (container, clean room ...) shall not degrade the performances of the telescope as defined in section 5.2.

5.1.3 Transportability and Handling

TEEN-015 The telescope shall be able to be transported fully assembled in any angular position between vertical and horizontal in an adequate transportation container, using the interface defined in section 3.5.1. The design of the telescope shall allow its handling in and out of the transport container and its handling during the tests and when integrated to the spacecraft.

TEEN-020 The container shall be compatible with class 1000 operations and equipped with shock recording. The containers shall be compatible with clean dry nitrogen or air purging.

TEEN-025 The design of the container for the telescope shall be compatible with all ground operations for a transport to and within Europe and in French Guyana and for a shipment from Europe to French Guyana, by boat and by road.

TEEN-030 The container shall ensure and shall record that the transportation environment (loads, temperatures, humidity,...) does not exceed the design specifications of the telescope given in the chapter 5 of this specification.

5.2 Pressure - Humidity

5.2.1 Pressure

TEEN-035 The Telescope shall withstand any external air pressure between ambient (0.115 MPa) to vacuum.

TEEN-040 The Telescope shall provide adequate means of venting and shall be able to cope with the depressurisation profile as defined in the ARIANE 5 Users Manual AD-8.

5.2.2 Humidity

TEEN-045 The Telescope shall be designed to withstand without degradation of its performance during storage a relative humidity (RH) of 0% RH to 95% RH, non-condensing.

5.3 Radiation

TEEN-050 All materials of the telescope shall be able to withstand the radiation environment (type, total dose and dose rate) as defined in the applicable document AD-1 with a safety factor of 2.

5.4 Cleanliness/Cleanability

TEEN-055 All non optical parts of the telescope shall be designed and manufactured such that they can be cleaned in order to remove accidental contamination deposited during on-ground operations.

TEEN-060 The cleanliness to be maintained during the on-ground operations and the in-orbit lifetime of the telescope shall be such that the telescope transmission does not degrade beyond the limits specified in Section 4.2.1. The exposure of the optical surfaces to the ambient has to be minimised. The telescope optical surfaces shall be covered and protected as much as possible during on-ground operations to prevent contamination.

TEEN-065 The optical surfaces of the telescope with their reflective surfaces shall be designed to withstand possible and exceptional (physical) cleaning operations without degradation of the performance of the telescope beyond specified values.

TEEN-070 The maximum molecular contamination for the telescope shall not exceed $2 \cdot 10^{-7} \text{g/cm}^2$ at delivery including the ground storage.

Obscuration ratio due to particulate contamination shall be smaller than 300 ppm at delivery to spacecraft contractor.

5.5 Thermal environment

5.5.1 Temperatures of the Telescope

TEEN-075 The telescope shall be designed to withstand with margins a temperature range from 55K to 358K in vacuum without performance degradation within the Temperature Performance range defined in TEPE-005.

TEEN-080 Furthermore, the telescope shall be able to withstand the temperatures defined in the table here below. The performance of the telescope specified in 4.2.1 shall not be degraded when it is tested in the temperature range here below.

Range Type	Min Temperature	Max Temperature (bake-out & contamination release)
<i>Acceptance Temperatures of the Telescope</i>	65 K*	318 K
<i>Qualification Temperatures of the Telescope</i>	60 K*	323 K

**Note: Depending on the temperature performance range defined in TEPE-005, the minimum temperature could be lowered. Gluing qualification temperature shall be performed down to 55K. It is not required that the above ranges are verified by test at telescope level but they shall, however, be verified on sample basis for a better evaluation of the performance of the telescope during its life in orbit.*

5.5.2 Thermal Shock/Thermal Cycling - Bake-Out

Thermal Shock

TEEN-085 The telescope with its optical coating shall be able to withstand a cooldown induced by a radiative temperature change of the thermal vacuum facility from Room temperature to 90K under vacuum within 5 hours.

Thermal Cycling

TEEN-090 The telescope shall withstand without degradation in vacuum three (3) cycles of temperature variations between 70K and 318K for acceptance or five (5) cycles of temperature variations between 70*

K and 323K for qualification. Each cycle shall include a soak time long enough to achieve thermal equilibrium of the telescope (the equilibrium condition is reached when any temperature rate-of-change is lower than 1°C/hour).*

()(TBC, depending on LHe facility)*

5.6 Design and Construction Requirements

5.6.1 Mechanical Stiffness Requirements

The telescope shall be designed to satisfy the following structural stiffness requirements:

- TEEN-095 - Longitudinal eigenfrequency > 60 Hz
- TEEN-100 - Lateral eigenfrequency > 45 Hz
- TEEN-105 - Local modes (i.e. with an effective mass or effective inertia w.r.t. the same reference frame less than 10% of the total mass or of the total corresponding inertia) shall be > 6 Hz in lateral direction and > 31 Hz in longitudinal direction.
- Torsion modes shall be > 45 Hz.

5.6.2 Design Limit loads

TEEN-110 The design limit loads shall be applied for the structural design considering in addition the safety factors defined in paragraph 5.6.3:

For Primary Reflector and its support

Case	Longitudinal	Lateral
1	12 g	4,6 g
2	3,2 g	10 g

For Secondary Reflector and its support (hexapod or else)

Case	Longitudinal	Lateral
1	12 g	35 g

*Longitudinal loads can have any sign.
Lateral loads can have any direction.*

NB: Design loads for the Secondary Reflector are valid up to the interface between the secondary reflector support and the Primary Reflector. The attachments are to be sized against these loads. Secondary reflector design loads are additive to Primary reflector design loads.

5.6.3 Mechanical Strength Requirements

5.6.3.1 Safety Factors

TEEN-115 The telescope shall withstand the worst combinations of mechanical and thermal loads without degradation.

TEEN-120 Following Safety Factors (SF) are defined for the dimensioning and verification of the equipment to cover uncertainties of load factor evaluation, material data and analysis as well as to avoid undesirable influences of manufacturing tolerances.

The Safety Factors shall be applied to the design limit loads, yield against permanent deformation, ultimate against rupture and loss of functionality.

Item	Yield SF	Ultimate SF	Buckling SF
<i>Conventional metallic materials and bolted joints</i>	1.1	1.5	2.0
<i>Unconventional materials</i>	1.4	2.0	2.0
<i>Inserts and glued joints</i>	1.5	2.0	NA

Definition of conventional and non-conventional materials:

Conventional materials:

All materials, also composites, for which sufficient statistical data are available to derive A values as defined in MIL-HDBK-5F, Section 1.4.11.

Unconventional materials, including SiC:

Those materials for which sufficient statistical data are not available.

Additional factors (e.g. fitting factors for load introduction points, stress concentration at cutouts or welding/casting factors, etc.) shall be justified by prior experience or test evidence.

5.6.3.2 Margins of Safety

TEEN-125 All structural elements shall be designed to exhibit a positive margin of safety (MOS) after application of the relevant safety factors (yield and ultimate) for all worst load cases.

The margin of safety is defined as the ratio of the allowable load (or stress) to the applied load (or stress):

$$MOS = \frac{\text{Allowable load (or stress)}}{\text{Applied load (or stress)}} - 1$$

5.6.4 Mechanical Interface Points characteristics

Environmental effect (AIT, launch, cool-down and in-orbit) on the Herschel payload module will induce strength and torque at the mechanical interface point of the telescope.

TEEN-130 The overall performance of the telescope defined in the § 4 shall be guaranteed when mounted on the PLM interface frame which mechanical characteristics are given in the following interface requirement drawings (ref DT0014975 ed2 rev 00).

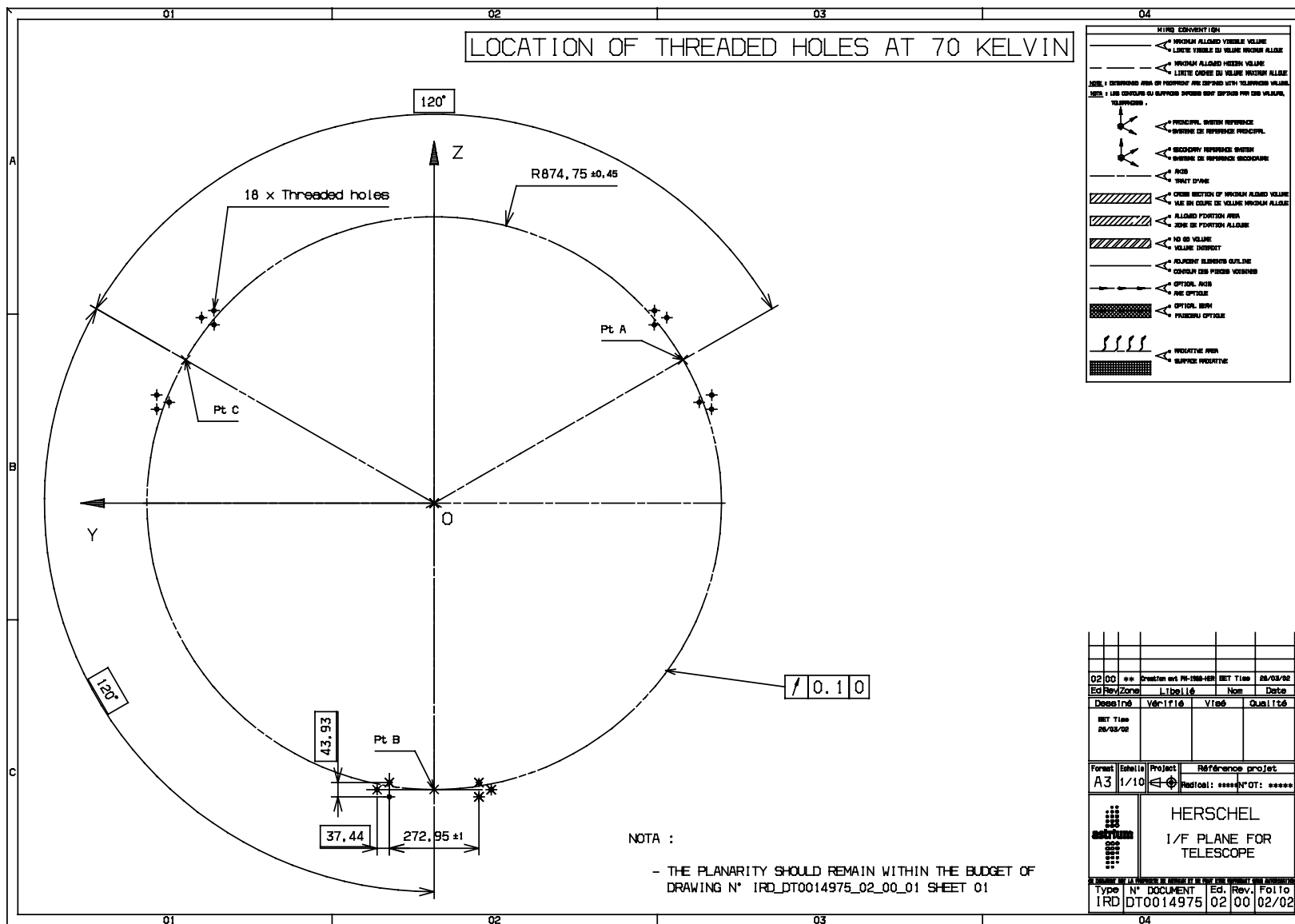

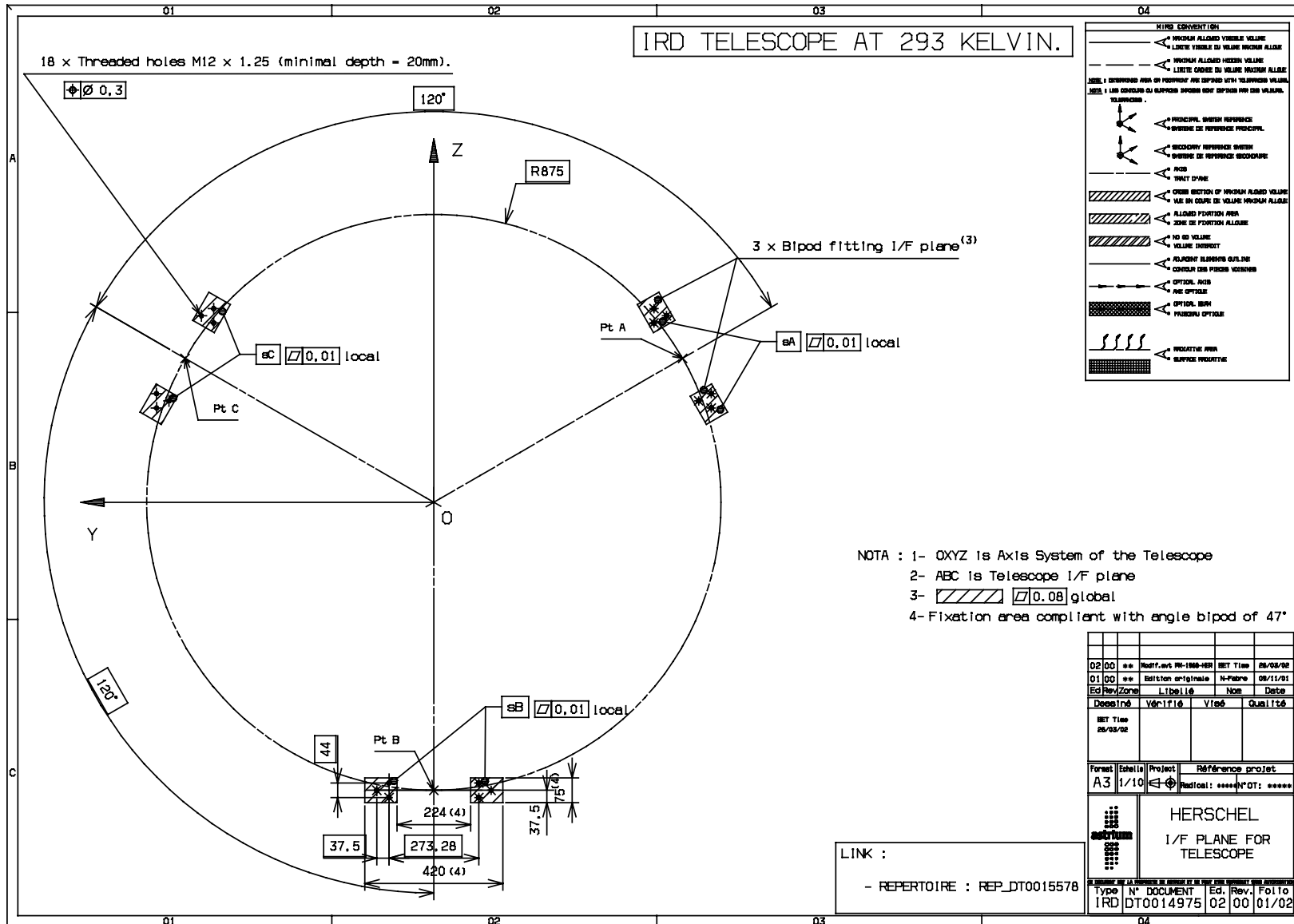

5.6.5 Sinusoidal Vibrations of the Telescope

During flight, the Herschel telescope is subjected to static and dynamic loads, which result from the Ariane 5 steady state acceleration and low frequency vibration.

5.6.5.1 Sinusoidal Test Levels

TEEN-135 The qualification sine vibration test spectrum to be applied at the base of the telescope is the following:

Vibration Type	Axis	Frequency	Vibration Level
Qualification sinusoidal vibration spectrum (sweep rate 2 Oct/min)	Y, Z (lateral)	5 Hz - 16 Hz 16 Hz - 20 Hz 20 Hz - 100 Hz	10 mm peak 10 g 2.5 g
	X (longitudinal: axis of symmetry)	5 Hz - 20 Hz 20 Hz - 30 Hz 30 Hz - 100 Hz	10 mm peak 12 g 2.5 g

The acceptance test levels are to be derived by dividing the qualification levels by a factor 1.5. Acceptance sweep rate is 4 Oct/min.

Note: A notching procedure can be agreed based on the dynamical analysis results and after a low level run.

TEEN-140 Low level sine test shall be performed to determine resonance frequencies to evaluate the behaviour of the test fixture and item integrity. Resonance search shall be carried out before and after vibration test for each axis between 5 to 2000 Hz with a level of 0.5 g (sweep rate: 2 Oct/min).

TEEN-145 During the sine vibration qualification tests, the loads on the primary and secondary reflector CoGs, and on the secondary reflector support (tripod or hexapod) shall not exceed the Design Limit Loads as defined in paragraph 5.6.2. The torsional mode on the secondary mirror will be measured with adapted instrumentation.

5.6.6 Acoustic Vibrations of the Telescope

During flight, the Herschel telescope is subjected to acoustic vibrations defined in the ARIANE 5 launcher User's Manual, AD-8.

TEEN-150 The spectra for the acoustic vibration tests are defined as follows:

Octave Band Centre Frequency (Hz)	Qualification Level	Acceptance Level (0 dB: ref. 2×10^{-5} Pascal)	Test Tolerance
31.5	132	128	-2, +4
63	134	130	-1, +3
125	139	135	-1, +3
250	143	139	-1, +3
500	138	134	-1, +3
1000	132	128	-1, +3
2000	128	124	-1, +3
Overall Level	146	142	-1, +3
Duration	2 min	1 min	

Note: The tolerances indicated in the above table allow for standard test-equipment inaccuracy.

5.7 Interchangeability

TEEN-155 Each element of the telescope shall be directly inter-changeable in form, fit and function with other element of the same part number (configuration item number). The performance characteristics and dimensions of like units shall be sufficiently uniform to permit interchange with a minimum of adjustment and re-calibration.

5.8 Maintenance

TEEN-160 The telescope design shall be such as to require a minimum of special tools, test equipment etc. to perform calibration, adjustment, fault identification and unit repair. Periodic maintenance requirements during storage and ground life shall be minimised and declared.

5.9 Reliability

TEEN-165 Electrical and electro-mechanical parts shall be selected in accordance with AD-5 and AD-9 and to optimise the reliability for the mission.

TEEN-170 Failure of one element shall not prevent the other from performing its intended function, nor the overall equipment from meeting its performance requirements.

5.10 Parts, Material and Processes

5.10.1 General

TEEN-175 The mechanical parts, material and processes shall comply with the requirements and environments as specified herein and with AD-3.

5.10.2 Dissimilar Metals

TEEN-180 To avoid electrolytic corrosion, dissimilar metals shall not be used in direct contact and shall comply with AD3. Exception can be made for Aluminium, Invar and Titanium if requested.

5.10.3 Magnetic Materials

TEEN-185 Magnetic materials shall be used only if necessary for equipment operation. Materials used shall minimise the permanent, induced and transient magnetic fields, with attention paid to minimising surface currents. Exception can be made for low CTE materials (such as Invar) if requested

5.10.4 Fungus Nutrient Materials

TEEN-190 Materials that are nutrients for fungus shall not be used.

5.10.5 Unstable Materials

TEEN-195 Unstable materials shall not be used.

5.10.6 Mechanical Parts

TEEN-200 The selection of mechanical parts shall be justified by analysis, evaluation tests and their qualification for the required application shall be demonstrated.

5.10.7 Finish

TEEN-205 The surfaces of each major item of telescope shall be adequately finished to prevent deterioration from exposure to the on-ground and in-orbit environments that might jeopardise fulfilment of the specified performance.

*(Additional information on finish such as plating requirements, type and thickness of paint, coatings, etc., may be specified as required).
Surface finish shall comply with the requirements document AD-7.*

5.10.8 Outgassing

*TEEN-210 Basic acceptable outgassing criteria for the selection of the materials are Total Mass Loss (TML) # 1% and Collected Volatile Condensable Material (CVCM) # 0.1%.
In case of materials used in the vicinity of optical elements, the more stringent requirement of Recovered Mass Loss (RML) # 0.10% and CVCM # 0.01% shall apply. It should be noted that outgassing characteristics are determined during a vacuum test at 125EC for 24 hours according to AD-4.*

5.10.9 Cleanliness/Contamination Control

TEEN-215 All parts, materials and processes used for the telescope shall be selected such that the telescope transmission specification can be met as given in 4.2

TEEN-220 The telescope shall be designed such that contamination sensitive surfaces can be covered by suitable means to minimise or to avoid contamination (see also AD-2)

TEEN-225 Optical surfaces shall comply with the requirements as defined in AD-7.

5.10.10 Susceptibility to Stress Corrosion

TEEN-230 Metallic materials selected shall have a high resistance to stress corrosion cracking according to AD-6.

5.10.11 Material brittleness

SiC material is known to be a brittle material due to its very low strain tolerance and the large scatter in its strength data.

TEEN-235 All SiC telescope elements (especially at the high stress areas) shall be carefully verified first by proper refined stress analysis then by a rigorous inspection using NDI techniques (or any equivalent) during and after manufacturing.

5.10.12 Grinding and polishing processes

TEEN-240 Adequate measurement methods shall be used during the grinding and polishing processes of the Primary and Secondary reflectors to monitor and predict regularly their optical performance.

5.11 EMC Requirements

TEEN-245 All exposed surfaces that can collect electrical charges shall be made conductive to avoid electro-static charge and particular contamination. The surface conductivity shall be better than 1 M Ω per square.

TEEN-250 All metallic items shall be electrically grounded with a resistance of less than 100 Ω to the interface grounding point.

5.12 Identification and Marking

TEEN-255 The identification and marking shall be done in accordance with the configuration item number respectively part designation, model designation, serial number as relevant and defined in the configuration control requirements.

5.13 Workmanship

TEEN-260 The Telescope Provider shall define workmanship requirements for the telescope items.

TEEN-265 The surface roughness R_q of the optical surfaces of the reflectors of the telescope shall be #0.6 μm .

TEEN-270 Telescope items hardware shall be accompanied with a set of workmanship samples representative for each lot/batch of the manufacturing and integration process.

The samples shall serve for following purposes:

- 1. evaluation of material integrity*
- 2. evaluation of surface reflectivity and stability*
- 3. evaluation /measurement of optical surfaces*
- 4. evaluation of the manufacturing parameters*
- 5. life samples*
- 6. contamination samples*
- 7. destructive samples for material characterisation*
- 8. others as required, i.e. reference/traceability samples*

Several samples shall be used as part of the qualification programme (e.g. coating durability).

5.14 Refurbishment

TEEN-275 The telescope shall survive all environmental testing and ground life without performance degradation and without the need for refurbishment.

5.15 Facilities

TEEN-280 All GSE items which will be used for handling and testing the telescope shall be delivered together with the telescope.

6 VERIFICATION REQUIREMENTS

6.1 Verification Methods, Programmes and Matrices

6.1.1 Verification Programme

TEVE-005 The Telescope Provider shall establish a verification plan, which shall be reviewed and approved by ESA. The plan shall define how the requirements are being verified. The verification can be done by test, analysis or inspection.

The plan shall define the:

- objective of the tests*
- type of test to be performed*
- sequence of tests*
- hardware to be tested*
- description/objectives of the qualification test*
- level of test parameters*
- special facilities/equipment needed*
- acceptance/rejection criteria.*

TEVE-010 During the development of the telescope and its primary reflector, the Telescope Provider shall evaluate and update the WFE budget. Annex A presents a typical WFE budget tree for the Herschel telescope.

6.1.2 Verification by tests and samples

TEVE-015 The test sequence for the verification of the telescope shall be performed in agreement with the table of Annex B which is given for guidance and information. Additional tests may be added if considered necessary.

TEVE-020 The Telescope Provider shall as part of his test/verification plan and procedures clearly define rejection/acceptance criteria in compliance with the objective of the test.

TEVE-025 The Telescope Provider shall define conditions when a retest may be acceptable.

TEVE-030 All samples used for verification in the development programme of the telescope shall be representative of the manufacturing process and of the environmental lifetime of the final telescope (i.e, thermal cycling, thermal shocks ...).

6.2 Analysis, Inspection and Test

TEVE-035 The requirement verification matrix shall be controlled by the Telescope Provider. Furthermore a rationale as to why various parameters are verified by analysis, inspection, similarity with other models or by testing shall be established by the Telescope Provider.

6.3 Telescope Verification Testing

6.3.1 Mechanical Verification Testing of the Telescope

TEVE-040 The mechanical verification of the telescope shall be performed in agreement with the specifications listed in section 5.6 and shall be performed before the thermal verification.

6.3.2 Thermal Verification Testing of the Telescope

TEVE-045 The verification of the optical performance of the telescope shall be performed by a combination of tests and analysis.

TEVE-050 The thermal qualification and acceptance testing of the telescope assembly shall be compatible with a LHe shroud cooled facility.

TEVE-055 The optical performance of both the flight and the flight spare model telescopes shall be as a minimum demonstrated for an average telescope temperature between 70 K and 90 K (TBC, depending on LHe facility). For both temperatures, the worst case environment w.r.t. temperature gradients as resulting from the cold, nominal and hot cases defined in paragraphs 3.5.2 and 5.5.1 shall be applied.

TEVE-060 The compatibility of the telescope design with the contamination release and dry-out temperatures as defined in para 5.5.1 shall be demonstrated by test for both the flight spare models.

TEVE-065 The compatibility of the qualification model of the telescope with the thermal cycling requirements as defined in para 5.5.2 shall be demonstrated by test.

TEVE-070 The compatibility of the flight spare model of the telescope with the thermal cycling requirements as defined in para 5.5.2 shall be demonstrated by test.

TEVE-075 The compatibility of the flight model of the telescope assembly with the thermal cycling requirements as defined in para 5.5.2 shall be demonstrated by test.



Herschel/Planck

Herschel Telescope Specification

Reference: SCI-PT-RS-04671

Date: 22 October 2002

Issue/Rev. No: 6/0

page: 37

ANNEX A: WFE TREE BUDGET VERIFICATION

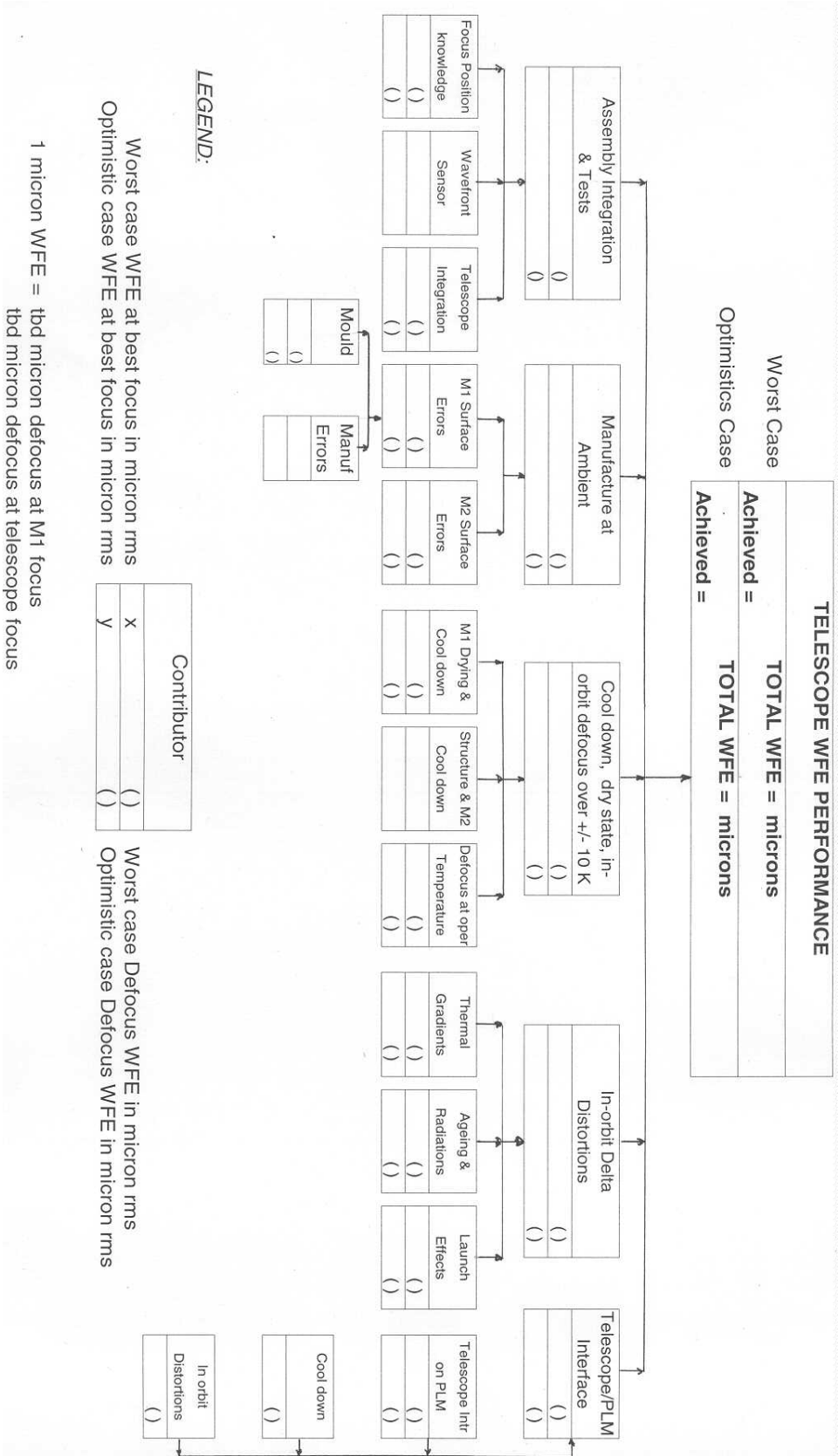

ANNEX B: TEST SEQUENCE

The test sequence for both the qualification model and the flight model of the telescope shall be as a minimum the following:

1. 3-D Contour measurement of the telescope
2. Optical Performance Measurement at Room Temperature
3. X, Y, Z axes Sine Vibrations
4. Optical Performance Measurement at Room Temperature
5. Acoustic Vibrations
6. Optical Performance Measurement at Room Temperature
7. Bake-out and Contamination Release in vacuum performed with heaters of telescope
8. Thermal Shock
9. Optical Performance Measurement at a temperature $< 90\text{K}$ (*)
10. Optical Performance Measurement at a temperature close to 70K (*)
11. Thermal Cycling
12. Optical Performance Measurement at a temperature $< 90\text{K}$ (*)
13. Optical Performance Measurement at a temperature close to 70K (*)

()(TBC, depending on LHe facility)*