

# SPIRE

**SUBJECT: INSTRUMENT REQUIREMENTS DOCUMENT**

**PREPARED BY: Bruce Swinyard (Custodian)  
Ken King**

**DOCUMENT No: SPIRE-RAL-PRJ-000034**

<b>ISSUE:</b>	<b>.20</b>	<b>Date:</b>	<b>15 September 1999</b>
	<b>.21</b>		<b>30 November 1999</b>
	<b>.30</b>		<b>May 2000</b>
	<b>.31</b>		<b>25 May 2000</b>
	<b>.32</b>		<b>July 2000</b>
	<b>1.0</b>		<b>23 November 2000</b>
	<b>1.1</b>		<b>10 January 2002</b>
	<b>1.2</b>		<b>30 May 2003</b>
	<b>1.3</b>		<b>14 July 2005</b>

**APPROVED BY: Matt Griffin**

**Date:**

**Eric Sawyer**

**Date:**

**Laurent Vigroux**

**Date:**

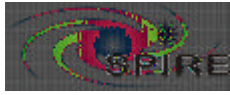

**Distribution**

**Matt Griffin**

**Laurent Vigroux**

**Walter Gear**

**Jean-Paul Baluteau**

**Ken King**

**Bruce Swinyard**

**Eric Sawyer**

**John Delderfield**

**Doug Griffin**

**Jean-Louis Augueres**

**Lionel Duband**

**Jamie Bock**

**Dominique Pouliquen**

**Berend Winter**

**Kjetil Dohlen**

**Peter Hargrave**

**David Smith**

**Hans-Gustav Floren**

**Riccardo Cerulli-Irelli**

**Sergio Molinari**

**Principal Investigator (Cardiff  
University)**

**Co-Principal Investigator (CEA)**

**Project Scientist**

**Project Scientist**

**Project Manager (RAL)**

**Instrument Scientist (RAL)**

**Instrument Manager (RAL)**

**Systems Engineer (RAL)**

**Systems Engineer (RAL)**

**CEA(Saclay)**

**CEA (Grenoble)**

**JPL/Caltech**

**LAM**

**MSSL**

**LAM**

**Cardiff**

**RAL**

**Stockholm**

**IFSI**

**IFSI**



### Change Record

ISSUE	DATE	
0.1	2 July 1999	First proper issue just prior to PDR
0.2	September 1999	Radically re-arranged separate instrument and sub-system reqs.
0.21	November 1999	Updated following comments from Berend Winter – this issue sent out for Warm Electronics Review
0.3	May 2000	Revised following detector selection. Removed extraneous information that is better covered in other documents. Revised organisation of document and removed redundant requirements and renumbered some of the sub-systems requirements. Added simulator requirements
0.31	25 May 2000	Re-integrated Warm Electronics requirements Official release following comments on version 3. Changes made to requirements on WE testing to bring into line with development plans. Block diagram changed to put shutter electronics into DRCU Change made to cooler requirements to include parasitic load from 4-2 K via structure and heat switches.
0.32	July	Working version – changes to detector and JFET box requirements to clarify for specification document.
1.0	23 November 2000 23 November 2001	First configuration controlled issue Change requests submitted against issue 1: <b>HR-SP-CDF-ECR-1</b> Changes to Calibrator Specs (section 3.5.9.1 and section 3.5.9.2) <b>HR-SP-CSA-ECR-1</b> Changes to Shutter Specs (section 3.5.3) <b>HR-SP-IFS1-ECR-1</b> IRD-OPS-R02, IRD-WE-R07 <b>HR-SP-IFS1-ECR-2</b> IRD-TLM-R02, IRD-DATA-R03 <b>HR-SP-IFS1-ECR-3</b> IRD-TLM-R06 <b>HR-SP-IFS1-ECR-4</b> IRD-WE-R29 <b>HR-SP-IFS1-ECR-5</b> IRD-WE-R30 <b>HR-SP-IFS1-ECR-6</b> IRD-WE-R31 HR- SP- RAL- ECR-16 IRD-BSMP-R01 HR- SP- RAL- ECR-17 IRD-DETP-R09; IRD-DETS-R10 HR- SP- RAL- ECR-18 IRD-DETP-R10; IRD-DETS-R11 HR- SP- RAL- ECR-19 IRD-DETP-R11; IRD-DETS-R12 HR- SP- RAL- ECR-20 IRD-RFM-R02 HR- SP- RAL- ECR-21 IRD-RFM-R08 HR- SP- RAL- ECR-22 Section 2.10 EMC Requirement inserted HR- SP- RAL- ECR-23 Section 3.5.12 Updated thermistor list HR- SP- RAL- ECR-24 IRD-SMEC-R07 HR- SP- RAL- ECR-25 IRD-SMEC-R08 HR- SP- RAL- ECR-26 IRD-SMEC-R12 HR- SP- RAL- ECR-27 IRD-STRC-R01 HR- SP- RAL- ECR-28 IRD-STRC-R02  Non-ECR changes AD and RD list brought up to date Herschel for FIRST everywhere through document Correctly numbered and name list edited

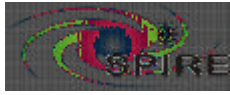

**INSTRUMENT REQUIREMENTS  
DOCUMENT**

1.2	May 2003	<p>HR-SP-RAL-ECR-043 on sensitivity affects values in section 2.2 – a waiver will be raised against the values here to better reflect the expected instrument performance</p> <p>HR-SP-RAL-RFW-001 on the change to the model philosophy affects descriptions in section 2.4;2.5 and 2.6 - note added to these sections</p> <p>HR-SP-RAL-ECR-032 Shutter deleted – update diagram in section 3.1 – update table –delete section 3.5.3.</p> <p>HR-SP-CDF-ECR-004 Changes to PCAL requirements to reflect larger aperture IRD-CALP-R01; IRD-CALP-R02</p> <p>General – “Checked by” box removed from the title page to facilitate signature.</p>
IQR	July 2005	<p>OPS-R02 changed from 100 kbs to 130 kbs to reflect change to IID-A</p> <p>Section 1</p> <p>Document list updated – references removed where not used – issue numbers changed to latest for Ads</p> <p>Added PSICD as applicable document</p> <p>Section 2</p> <p>L3 thermal stage added to table 2-2</p> <p>2.2</p> <p>Photometer performance requirements now checked - all TBC and TBD removed</p> <p>Spectrometer performance requirements now checked - all TBC and TBD removed</p> <p>All sections – upper level requirements added where missing - cross referenced into IID-B or IID-A where appropriate.</p> <p>New requirement added for SOB connection to L1</p> <p>New requirements added for Phot and Spec detector box thermal connections to L0</p> <p>New Requirements added for Phot and Spec box electrical isolation</p> <p>New requirements added for JFET structure thermal isolation from HOB and connection to L3</p> <p>New requirement added on WE location</p> <p>New requirement added on DPU bus address for prime and redundant sides</p>



**Table of Contents**

**1. INTRODUCTION.....3**

1.1 PURPOSE.....3

1.2 SCOPE.....3

1.3 GLOSSARY .....3

1.4 REFERENCES.....4

    1.4.1 *Applicable Documents* .....4

    1.4.2 *Reference Documents*.....5

1.5 DOCUMENT OVERVIEW.....5

**2. INSTRUMENT LEVEL REQUIREMENTS.....7**

2.1 GENERAL DESCRIPTION .....7

    2.1.1 *Instrument Description*.....7

    2.1.2 *Mission Context*.....7

    2.1.3 *Definition of Instrument Elements and Instrument Location* .....9

    2.1.4 *Satellite Level Constraints and Assumptions*.....10

    2.1.4 *Satellite Level Constraints and Assumptions*.....11

        2.1.4.1 Herschel Cryostat .....11

        2.1.4.2 Warm Electronics Power.....12

        2.1.4.3 Telemetry Rates .....12

        2.1.4.4 Herschel Telescope.....12

        2.1.4.5 Pointing.....12

        2.1.4.6 Launch Environment .....13

        2.1.4.7 Orbit.....13

        2.1.4.8 Mission Lifetime.....13

        2.1.4.9 Radiation environment .....13

        2.1.4.10 Operational Environment .....13

2.2 INSTRUMENT PERFORMANCE REQUIREMENTS .....15

    2.2.1 *Photometer Requirements*.....15

    2.2.2 *Spectrometer Requirements*.....16

2.3 INSTRUMENT OPERATIONS REQUIREMENTS.....19

    2.3.1 *Instrument Operations*.....19

    2.3.2 *Operating Modes*.....19

    2.3.3 *Commanding Requirements* .....20

REQUIREMENT ID.....20

    2.3.4 *Telemetry Requirements*.....22

*Data Handling Requirements*.....23

    2.3.5.....23

2.4 INSTRUMENT MODEL PHILOSOPHY .....25

2.5 INSTRUMENT LEVEL QUALIFICATION .....27

2.6 VERIFICATION.....28

2.7 SAFETY .....30

2.8 AUTONOMY .....31

2.9 RELIABILITY AND REDUNDANCY .....32

2.10 EMC.....33

**3. SUBSYSTEMS REQUIREMENTS .....34**

3.1 ASSUMPTIONS.....34

3.2 SCOPE.....36

3.3 SUBSYSTEM QUALIFICATION REQUIREMENTS.....36

3.4 ASSUMPTIONS FOR THE FOCAL PLANE UNIT .....37

    3.4.1 *Plate Scale*.....37



**INSTRUMENT REQUIREMENTS  
DOCUMENT**

3.4.2	Vacuum.....	37
3.4.3	Mass.....	37
3.5	COLD UNITS SUB-SYSTEM REQUIREMENTS.....	38
3.5.1	Structure.....	38
3.5.1.1	Common Structure.....	38
3.5.1.2	Photometer Structure.....	40
3.5.1.3	Spectrometer Structure.....	41
3.5.2	<sup>3</sup> He Cooler and 300 mK architecture.....	43
3.5.3	Shutter.....	45
3.5.4	Harness.....	46
3.5.5	Optics and Filters.....	47
3.5.5.1	Photometer Optics and Filters.....	47
3.5.5.2	Spectrometer Optics and Filters.....	48
3.5.6	Detectors.....	50
3.5.6.1	Photometer Detectors.....	50
3.5.6.2	Spectrometer Detectors.....	51
3.5.7	Beam Steering Mechanism.....	54
3.5.8	Spectrometer Mirror Mechanism and Position Measurement System.....	56
3.5.9	Calibration Sources.....	58
3.5.9.1	Photometer Calibration Source.....	58
3.5.9.2	Spectrometer Calibration Source.....	59
3.5.10	JFET Boxes.....	61
3.5.11	FPU RF Filter Modules.....	63
3.5.12	Instrument thermometry.....	64
3.6	WARM ELECTRONICS.....	66
3.6.1	Functional Requirements.....	66
3.6.1.1	External Functional Requirements.....	66
3.6.1.2	Internal Functional Requirements.....	67
3.6.2	Interface Requirements.....	68
3.6.3	Performance Requirements.....	68
3.6.4	Autonomy Requirements.....	69
3.6.5	Reliability Requirements.....	69
3.6.6	Safety Requirements.....	69
3.6.7	Budgets.....	70
3.6.8	Compatibility Requirements.....	70
3.6.9	Quality Requirements.....	70
3.6.10	Location.....	70
3.6.11	Bus Address.....	71
3.7	INSTRUMENT SIMULATORS.....	72
3.7.1	FPU Simulator.....	72
3.7.2	DRCU Simulator.....	72



## 1. INTRODUCTION

### 1.1 Purpose

This document describes the capabilities required of the SPIRE instrument and the constraints placed upon its design and operation in the context of the Herschel mission.

The instrument requirements are derived from the scientific requirements placed on the instrument in the SPIRE Science Requirements Document (SRD); the constraints imposed upon the instrument design by the satellite interface specification as detailed in the Instrument Interface Document parts A and B (IID-A and IID-B) and the operational constraints on the instrument design given in the Herschel/Planck Operations Interface Requirements Document (OIRD).

This document goes beyond the general instrument level requirements to place specific requirements on individual sub-systems within the context of the instrument design specification. It thus forms the starting point for the SPIRE sub-system specification documents that will be written for each SPIRE sub-system.

The requirements set out in this document will be used to verify the performance of the instrument during instrument level Assembly, Integration and Verification (AIV). The sub-system requirements will be used as the bench mark for sub-system acceptance at instrument level. If there is an outside source for the requirements on the instrument it will be referenced, if not this document in the source.

### 1.2 Scope

This documents deals with the requirements on the SPIRE instrument hardware and software from the optical input from the Herschel telescope through to the interfaces with the spacecraft. It does not deal with the requirements on the SPIRE Instrument Control Centre or any other part of the instrument ground segment.

### 1.3 Glossary

AIV	Assembly Integration and Verification
AOCS	Attitude and Orbit Control System
ASIC	Application Specific Integrated Circuit
AVM	Avionics Model
BSM	Beam Steering Mechanism
CDMS	Command and Data Management System (on Spacecraft)
CQM	Cryogenic Qualification Model
CVV	Cryostat Vacuum Vessel
DCRU	Detector Control and Readout Unit
DPU	Digital Processing Unit
EMC	Electromagnetic Compatibility
EMI	Electromagnetic Interference
FOV	Field of View
FPU	Focal Plane Unit
FS	Flight Spare



FTS	Fourier Transform Spectrometer
FWHM	Full Width Half Maximum
HCSS	Herschel Common Science System
HIFI	Heterodyne Instrument For Infrared
IID-A	Instrument Interface Document part A
IID-B	Instrument Interface Document part B
JFET	Junction Field Effect Transistor
MGSE	Mechanical Ground Support Equipment
NEP	Noise Equivalent Power
OBDH	On Board Data Handling (on Spacecraft)
OGSE	Optical Ground Support Equipment
OIRD	Operations Interface Requirements Document
OPD	Optical Path Difference
PACS	Photodetector Array Camera and Spectrometer
PDU	Power Distribution Unit (on spacecraft)
PFM	Proto-Flight Model
PLM	Payload Module
QLF	Quick Look Facility
S/C	Space Craft
SPIRE	Spectral and Photometric Imaging Receiver
SRD	Science Requirements Document
STM	Structural Thermal Model
SVM	Service Module
TBD	To Be Determined
TBC	To Be Confirmed

Table A: Glossary of acronyms and abbreviations

## 1.4 References

Where there are differences in requirements or specification details, the applicable and reference documents enumerated here take precedence over the Instrument Requirements Document. This is particularly the case with the IID-A and IID-B which will contain the interface specification between the SPIRE instrument and the Herschel satellite.

### 1.4.1 Applicable Documents

Document Reference	Name	Number/version/date
AD1	Herschel/Planck Instrument Interface Document Part A (IID-A)	PT-IID-A-04624 Issue 3.3 June 2004 SPIRE-ESA-DOC-000178
AD2	SPIRE Scientific Requirements Document (SRD)	Version 3.0 November 2000 SPIRE-UCF-DOC-000064
AD3	FIRST/PLANCK Operations Interface Requirements Document (FOIRD)	SCI-PT-RS-07360 Issue 2.2 Sept 2003 SPIRE-ESA-DOC-000188





AD4	Herschel Science Operations Implementation Requirements Document (SIRD)	PT-03646 Issue 1.2 May 2003 SPIRE-ESA-DOC-000198
AD5	Herschel/Planck Instrument Interface Document Part B (IID-B) Instrument "SPIRE"	PT-SPIRE-02124 Issue 3.3 June 2004 SPIRE-ESA-DOC-000275
AD6	Herschel/Planck Packet Structure Interface Control Document	SCI-PT-ICD-07527 issue 5 July 2004

**Table B: Applicable Documents**

The abbreviations in brackets are used throughout the present document.

**1.4.2 Reference Documents**

Document Reference	Name	Number/version
RD1	FIRST L-2 Radiation Environment	esa/estec/wma/he/FIRST/3 04 March 1997 SPIRE-ESA-NOT-000401
	Deleted	
RD3	ESA Packet Utilisation Standard	ESA-PSS-07-101 Issue 1 May 1994 SPIRE-ESA-DOC-000243
	Deleted	
RD5	SPIRE Optics Error Budgets	SPIRE-LAM-DOC-000446
RD6	FIRST Instrument I/F Study Final Report	FIRST-GR-B0000.009 Issue 1 02 February 2000 SPIRE-REF-DOC-000417
RD7	SPIRE Instrument AIV Plan	SPIRE-RAL-DOC-000410
RD8	SPIRE Systems Budgets	SPIRE-ATC-PRJ-000450
	Deleted – not referenced in text	Not issued
	Deleted - not referenced in text	
	Deleted - not referenced in text	
RD12	SPIRE Harness Definition Document	SPIRE-RAL-PRJ-000608
RD13	SPIRE Instrument Grounding Philosophy	SPIRE-RAL-PRJ-000624
RD14	SPIRE Operating Modes Document	SPIRE-RAL-PRJ-000320
RD15	SPIRE Thermal Design Requirements	SPIRE-RAL-PRJ-002075

**Table C: Reference documents**

The abbreviations in brackets are used throughout the present document. Where version numbers are not supplied the latest issues should be obtained from the configured documents list.

**1.5 Document Overview**

The context within which the SPIRE instrument is to be operated and for which it is designed is outlined in section 2.1 together with an outline description of the conceptual design of the instrument. The requirements placed on the instrument performance in the Science Requirements Document are enumerated in section 2.2 and the requirements placed on the operation of the instrument in order to



**INSTRUMENT REQUIREMENTS  
DOCUMENT**

meet the scientific requirements are described in section 2.3. Sections 2.4-2.7 give the requirements placed upon the instrument design by the satellite launch and operations environments.

In chapter 3 the specific requirements placed on each sub-system of the SPIRE instrument are detailed. This starts from the generic requirements on all sub-systems for qualification and verification in sections 3.1 and 3.2. Each sub-system is then taken in turn, starting with the cold focal plane unit and ending with the warm electronics.

The details of various aspects of the qualification tests and the expected mass, power and thermal dissipation budgets available for the various sub-systems are given in the appendices.



## 2. INSTRUMENT LEVEL REQUIREMENTS

### 2.1 General Description

#### 2.1.1 Instrument Description

SPIRE (Spectral & Photometric Imaging REceiver) is a bolometer instrument comprising a three-band imaging photometer covering the 200-600  $\mu\text{m}$  range and an imaging Fourier Transform Spectrometer (FTS) with a spectral resolution of at least  $0.4 \text{ cm}^{-1}$  (corresponding to  $\lambda/\Delta\lambda = 100$  at 250  $\mu\text{m}$ ), covering wavelengths between 200 and 670  $\mu\text{m}$ . The detectors are bolometer arrays cooled to 300 mK using a  $^3\text{He}$  refrigerator. The photometer is optimised for deep photometric surveys, and can observe simultaneously the same field of view of at least 4 x 4 arcminutes in all three bands.

#### 2.1.2 Mission Context

SPIRE is one of three instruments to be placed on board the ESA Far InfraRed and Submillimetre Telescope (Herschel) satellite. This mission is dedicated to astronomical observations in the 85 to 700  $\mu\text{m}$  waveband.

The Herschel satellite provides a 3.5 m telescope for receiving and imaging the FIR and submillimetre radiation from astronomical sources. The three instrument Focal Plane Units (FPUs) share the 0.25 degree focal plane of the Herschel telescope and each instrument provides re-imaging optics to take its the portion of the focal plane onto its detectors. The signals from the SPIRE instrument are, after suitable conditioning and conversion to digital format, sent to the ground via the spacecraft Command and Data Management System (CDMS).

In order to prevent the instrument detectors being swamped by self emission, the FPUs are located in the Herschel cryostat. This is a liquid helium (LHe) cryostat providing various temperature levels, the lowest of these is the super-fluid LHe tank at 1.7 K. There are also two cold gas vent lines – the actual temperatures these provide are dependent on the details of the instrument thermal dissipation and the cryostat design (see section 2.1.4.1). The three instrument FPUs mechanically interface to the cryostat via a common optical bench with separate thermal straps to the cryostat. The signal conditioning “warm electronics” units will be placed on the satellite service module (SVM). The electrical connections between the warm electronics and the cold FPU are made through a cryo-harness that will be provided as part of the satellite system.

The Herschel mission will be controlled from the Mission Operations Centre (MOC) via a remote ground station. The SPIRE instrument will be controlled from the SPIRE Instrument Control Centre (ICC) which communicates to the MOC via the Herschel Common Science System (HCSS). The Herschel observers will interface to the mission via the Herschel Science Centre (HSC) which also communicates to the MOC via FINDAS.

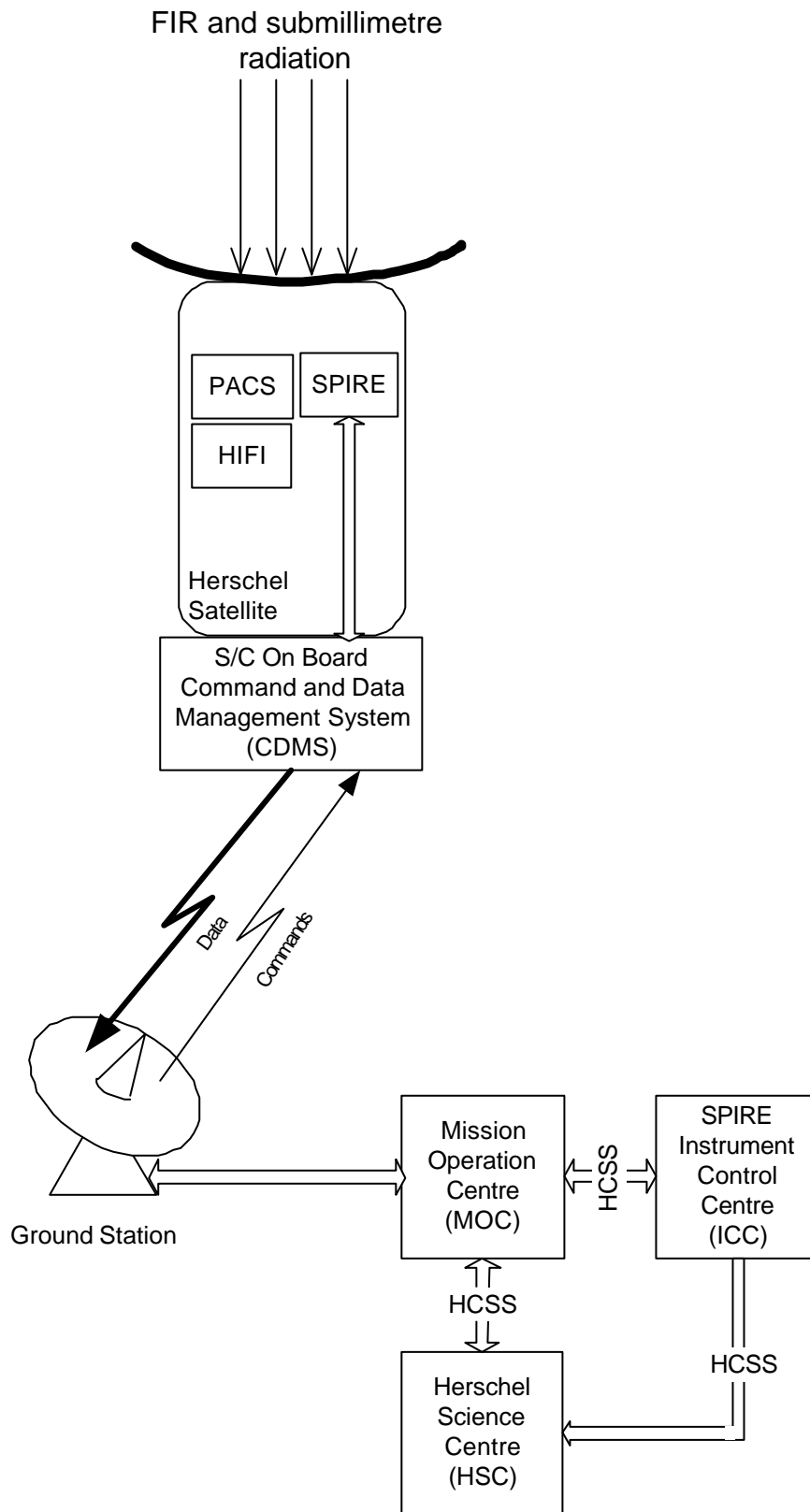

**Figure 2-1: The Herschel Mission showing the communication between the various elements**



### 2.1.3 Definition of Instrument Elements and Instrument Location

The SPIRE instrument consists of several “units” as defined in the IID-B and recapitulated in table 2.1-1 together with brief descriptions of their functions and their locations on the Herschelsatellite. These are subject to revision as the detailed design of the instrument proceeds but are given here for reference.

<b>Instrument unit</b>	<b>Function</b>	<b>ESA code</b>	<b>Location</b>
Cold Focal Plane Unit (FPU)	Contains the optics; mechanisms and detectors.	HSFPU	On Herschel optical bench inside cryostat
Focal plane JFET boxes (JFP and JFS)	These units contains the cold read-out electronics for the NTD germanium bolometers. There will be one each for the spectrometer (JFS) and photometer channels (JFP) in the SPIRE instrument	HSJFP FSJFS	On Herschel optical bench inside cryostat
Detector Read-out and Control Unit (DRCU)	These warm electronics units contains the circuitry necessary to read-out the detectors; control the various mechanisms and provide instrument control and data handling functions. The FCU contains the power supply unit; mechanism control unit and the sub-system control unit which conditions thermistors and heaters. The DCU contains the electronics to drive the detectors and JFETS and condition the detector signals.	HSFCU HSDCU	On spacecraft service module (SVM)
Digital Processing Unit (DPU)	This warm electronics unit provides the instrument interface to the S/C CDMS sub-system; receives and interprets instrument commands and formats the instrument data for telemetry to the ground	HSDPU	On SVM
Warm interconnect harnesses (HARNESS)	This connects the warm electronics units.	HSWIH	On SVM

**Table 2.1-1: Definition and location of the elements of the SPIRE instrument.**



# INSTRUMENT REQUIREMENTS DOCUMENT

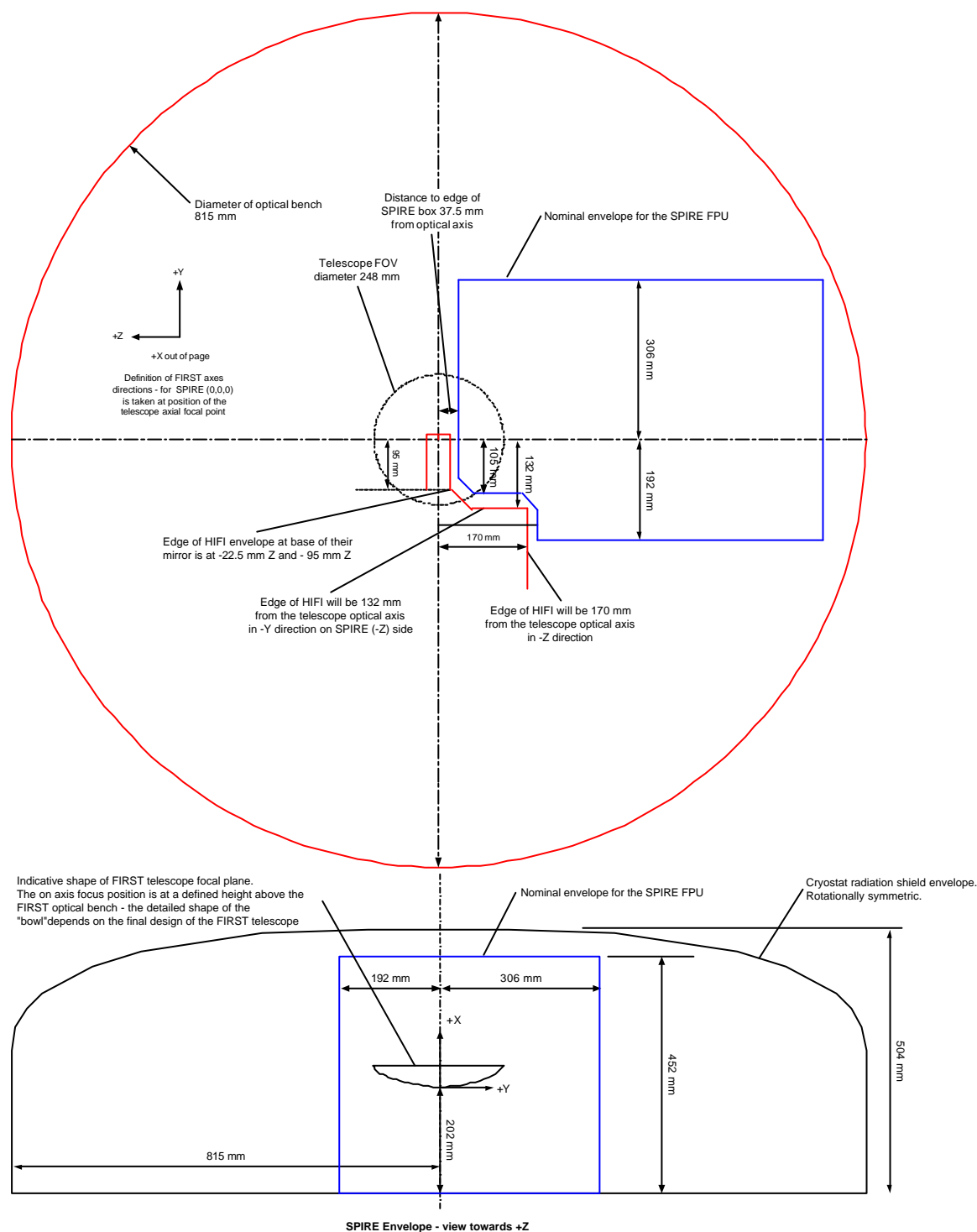

**Figure 2-2: Cold FPU location and envelope constraints in the Herschel cryostat. The cryostat cover is rotationally symmetric and defines the X-Z envelope of the instrument box as well (not shown). The details of the box shape are subject to revision as the design evolves and the instrument dimensions are for illustrative purposes only.**



## Satellite Level Constraints and Assumptions

The specification and capabilities of the Herschel satellite are given in the IID-A. As this document is under review and unlikely to be finalised in the near term, the assumptions that should be made about the Herschel

satellite for the purposes of the SPIRE instrument requirements are described in this section.

### 2.1.4.1 Herschel Cryostat

The thermal behaviour of the Herschel cryostat will be complex and depends both on its final design and that of the instruments. The results of a study into the expected temperatures that will be provided by the Herschel cryostat (RD6) shows that the temperatures of the three thermal interfaces are as given in table 2-2.

Description	Cooling Method and Comments	Nominal Temperature
LHe tank "Level 0"	The pumped LHe will be super-fluid and provide a very large thermal sink	1.7 K
Helium Vent Line "Level 1"	Cooled by cryostat boil off gas – temperature will depend on rate of boil off and instrument dissipation	5.2 K
Helium Vent Line "Level 2"	Strapped to helium gas vent line after level 1 connection. That is the temperature of the gas will depend on the thermal dissipation from the instruments at level 1.	11 K
Helium Vent Line "Level 3"	Strapped to helium gas vent line after level 2 connection. That is the temperature of the gas will depend on the thermal dissipation from the instruments at level 1 and level 2.	15 K

**Table 2-2: Temperature stages available from the Herschel cryostat.**

The permissible dissipation from the FPU at the various temperatures is defined in the IID-B (table 5.7-1). An illustration of the expected levels of dissipation is given in the SPIRE Sub-system Budget Allocation (RD8).

The Herschel cryostat defines the available space envelope for the instruments. The SPIRE envelope is further restricted by the neighbouring HIFI instrument. Figure 2-2 shows the approximate location of the SPIRE instrument, the definition of the spacecraft axes and the available space envelope. The shape of the Herschel cryostat cover that defines the cold FPU space envelope is given in the IID-A and repeated in table 2-3 for completeness.



X (mm)	Y (mm)	Z (mm)
0	0	815
271	0	815
315	0	807
350	0	787
379	0	758
431	0	662
461	0	563
497	0	337
504	0	135

**Table 2-3: Dimensions of the Herschel cryostat shield that defines the envelope for the instruments. The shield is rotationally symmetric and, when this definition was provided, the hole in the top had a radius of 135 mm. This is subject to revision depending on the detailed design of the telescope.**

#### 2.1.4.2 Warm Electronics Power

The SPIRE instrument has requested up to 100 W total.

#### 2.1.4.3 Telemetry Rates

The average telemetry rate available to each instrument over the operational cycle of the Herschel satellite is 130 kbps.

#### 2.1.4.4 Herschel Telescope

The Herschel telescope defines the optical “environment” in which the SPIRE instrument has to operate. In particular the field of view; the plate scale and speed of the beam. The current specification for the Herschel telescope is given in the IID-A section 4.3.1. It is base lined as having the following optical specification:

Primary mirror diameter: 3.5 m

Focal length: 28.5 m

Focal Ratio: f/8.68

Back focal length: 975 mm – defined from the primary vertex

Field of view: circular - radius 0.25 degrees

Height of on-axis focus above optical bench: 202 mm

Plate scale: 7.237 arcsec/mm

Diameter of unvignetted field of view at the focal plane: 245 mm

#### 2.1.4.5 Pointing

The pointing capabilities of the Herschel satellite are given in the IID-A. The satellite has a requirement to “blind point” to within 3.7 arcsec and a goal to do this within 1.5 arcsec. Both these figures are 1-sigma values and are referred to the optical axis. If the goal is not achieved then a “peak-up” operation mode may be required.





The satellite has the ability to perform both pointed raster observations and fast scans across the sky. For the raster mode the relative accuracy between pointings will be better than 0.5 arcsec. In scan mode the satellite can be scanned over a large angular range from 0.1 arcsec/sec to 60 arcsec/sec with a resolution of 0.1 arcsec/sec. This mode can be used in “line scan” to build up maps of large areas of the sky.

The satellite can be nodded from one position to another with a duty cycle of at least 80% for a throw of 5 arcmin with a dwell time of 72 seconds at each position. The details of any actual SPIRE specific requirement on the nodding capability of the satellite are to be determined.

#### **2.1.4.6 Launch Environment**

The satellite will be launched on an Ariane V from Kourou. The expected environment is specified in the IID-A.

The cold FPU and JFET box (FTB) will be launched in vacuum and at cryogenic temperatures. The warm electronics units will be launched at ambient temperatures and atmospheric pressure.

#### **2.1.4.7 Orbit**

The Herschel satellite will be placed into a Lissajous orbit around the L2 libration point  $1.5 \times 10^6$  km from the Earth on the Earth-Sun line.

#### **2.1.4.8 Mission Lifetime**

The baseline mission lifetime is 3.5 years (IID-A); the expected lifetime of the cryogen is nearer 4.25 years. This should be the figure used for estimation of number of operations and reliability of SPIRE sub-systems and the corresponding life tests that will be required.

#### **2.1.4.9 Radiation environment**

RD2 gives calculated fluence and doses for the mission. The integrated dose for silicon behind 2 mm of aluminium is estimated at 12 kRad and behind 5 mm of aluminium as 3.5 kRad. These figures will be taken as the radiation tolerance for components in the warm electronics boxes and inside the cryostat respectively.

#### **2.1.4.10 Operational Environment**

In normal operations the satellite is expected to have a 24-hour operational cycle with data being collected autonomously for 21 hours and a 3 hour ground contact period – the Data Transfer and Commanding Period (DTCP). During the DTCP the data will be telemetered to the ground and the commands for the next 24-hour period will be uplinked.

This operational environment requires the instrument to undertake autonomous health and safety monitoring and to be capable of reacting to safety critical situations in real time to prevent damage to the instrument. It is expected that some health and safety tasks will be undertaken by the satellite CDMS.

It is expected that the observing schedule will be carried out as a series of fixed time operations. It is also expected that the satellite CDMS will store the instrument commands and provide the commands at the appropriate time intervals to the instrument to carry out the fixed time observation schedule. This



Project Document

**INSTRUMENT REQUIREMENTS  
DOCUMENT**

**Ref:** SPIRE-RAL-PRJ-000034

**Issue:** 1.3

**Date:** 14 July 2005

**Page:** Page 14 of 78

implies that the instrument does not need to store a large number of commands or to know the absolute time a command should be executed.



## 2.2 Instrument Performance Requirements

Note in version 1.2: The requirements on performance give here are subject to a request for waiver to reflect the known performance of the detectors and more accurate analysis of the thermal performance of the instrument.

### 2.2.1 Photometer Requirements

The basic scientific requirements for the SPIRE photometer are described in the SRD (AD2). The predicted instrument sensitivities, based on the current instrument design assumptions, and which are compatible with the scientific requirements, are given in Table 2.2-1. The assumptions used in the calculation of the sensitivities are given in the IID-B (RD1) Chapter 4.

Requirement ID	Description	Wavelength Range			Reference
		250 mm	350 mm	500 mm	
IRD-PHOT-R01	Nominal passband ( $\lambda/\Delta\lambda$ )	3	3	3	SRD section 1.2
IRD-PHOT-R02	Field of View (Arcmin) Req. Goal	4 x 4	4 x 4	4 x 4	SRD R7
		4 x 8	4 x 8	4 x 8	
IRD-PHOT-R03	Beam FWHM (Arcsec)	18 <sup>1</sup>	25 <sup>1</sup>	36 <sup>1</sup>	SRD R1
IRD-PHOT-R04	Point source sensitivity 1 $\sigma$ -1 sec (mJy) 1 $\sigma$ -1 hr (mJy)	34	35	41	SRD R1
		0.6	0.6	0.7	
IRD-PHOT-R05	Mapping sensitivity for one FOV 1 $\sigma$ -1 hr (mJy)				SRD R2
		1.4	1.5	1.9	

<sup>1</sup> Beams on sky to be diffraction limited – these values are indicative and depend on the detailed implementation of the optics.

**Table 2.2-1: Summary of Photometer scientific requirements and sensitivities**

In addition to the basic requirements, the SRD specifies “design” drivers and goals for the photometer design – these are described in Table 2.2-2.

Requirement ID	Description	Reference
IRD-PHOT-R06	Maximising 'mapping speed' at which confusion limit is reached over a large area of sky is the primary science driver. This means maximising sensitivity and field-of-view (FOV) but NOT at the expense of spatial resolution.	SRD R3
IRD-PHOT-R07	<i>Removed version 1.0</i>	
IRD-PHOT-R08	<i>Removed version 1.0</i>	
IRD-PHOT-R09	<i>Removed version 1.0</i>	
IRD-PHOT-R10	Field distortion must be <10% across the FOV	SRD R6

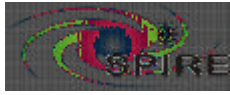

Requirement ID	Description	Reference
IRD-PHOT-R11	Electrical crosstalk should be <1% (goal 0.5%) between nearest-neighbour pixels and <0.1 % (goal 0.05%) between all other pixels in the same array.	SRD R8
IRD-PHOT-R12	NEP variation should be < 20% across each array.	SRD R10
IRD-PHOT-R13	The photometer dynamic range for astronomical signals shall be > 12 bits.	SRD R11
IRD-PHOT-R14	Absolute photometric accuracy should be <15% at all wavelengths with a goal of <10%	SRD R12
IRD-PHOT-R15	The relative photometric accuracy shall be <10% with a goal of <5%	SRD R13
IRD-PHOT-R16	The three arrays need to be co-aligned to within 1 arcsecond.	SRD R15
IRD-PHOT-R17	The maximum available chop throw shall be at least 4 arcminutes; the minimum shall be 10 arcsecs or less	SRD R9
IRD-PHOT-R18	SPIRE Photometric measurements shall be linear to 5% over a dynamic range of 4000 for astronomical signals	SRD R14

**Table 2.2-2: Summary of Photometer performance requirements from the SPIRE Science Requirements Document.**

### 2.2.2 Spectrometer Requirements

The basic scientific requirements for the SPIRE FTS are described in the SRD. The predicted instrument sensitivities, based on the current instrument design assumptions, and which are compatible with the scientific requirements, are given in Table 2.2-3. The assumptions used in the calculation of the sensitivities are given in the IID-B Chapter 4.

Requirement ID	Description	Value	Reference
IRD-SPEC-R01	Wavelength range: Band A Band B	200 – 300 $\mu\text{m}$ 300 – 700 $\mu\text{m}$	SRD R16
IRD-SPEC-R02	Maximum Resolution ( $\text{cm}^{-1}$ ) Req. Goal	0.4 0.04	SRD R22
IRD-SPEC-R03	Minimum Resolution ( $\text{cm}^{-1}$ ) Req. Goal	2 4	SRD R20
IRD-SPEC-R04	Field of View (Arcmin)	2.6 diameter circular for feedhorns	SRD R16
IRD-SPEC-R05	Beam FWHM (Arcsec) Band A (250 $\mu\text{m}$ ) Band B (350 $\mu\text{m}$ )	18 <sup>1</sup> 25 <sup>1</sup>	SRD R16
IRD-SPEC-R06	Point source continuum sensitivity (mJy; 1 $\sigma$ -1 hr;	Band A 200-300 $\mu\text{m}$ 47 Band B 300-400 $\mu\text{m}$ 43	SRD section 1.2

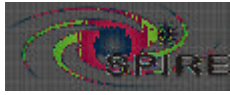

**INSTRUMENT REQUIREMENTS DOCUMENT**

Requirement ID	Description	Value	Reference
	0.4 cm <sup>-1</sup> resolution) Point source unresolved line sensitivity (W m <sup>-2</sup> ; 1 σ -1 hr)	Band B 400-700 μm No requirement Band A 200-300 μm 5.6 x 10 <sup>-18</sup> Band B 300-400 μm 5.1 x 10 <sup>-18</sup> Band B 400-700 μm No requirement	
IRD-SPEC-R07	Map continuum sensitivity (mJy; 1 σ -1 hr; 0.4 cm <sup>-1</sup> resolution) Map line sensitivity (W m <sup>-2</sup> ; 1 σ -1 hr)	Band A 200-300 μm 108 Band B 300-400 μm 104 Band B 400-700 μm No requirement Band A 200-300 μm 1.3 x 10 <sup>-17</sup> Band B 300-400 μm 1.3 x 10 <sup>-17</sup> Band B 400-700 μm No requirement	SRD section 1.2

<sup>1</sup>Beams on sky to be diffraction limited – these values are indicative and depend on the detailed implementation of the optics.

**Table 2.2-3: Summary of Spectrometer scientific requirements and sensitivities.**

In addition to the basic requirements, RD2 specifies “design” drivers and goals for the photometer design – these are given in Table 2.2-4.

Requirement ID	Description	Reference
IRD-SPEC-R08	The spectrometer design shall be optimised for sensitivity to point sources	SRD R16
IRD-SPEC-R11	The width of the FTS instrument response function shall be uniform to within 10% across the FOV for resolution <0.4 cm <sup>-1</sup>	SRD R21
IRD-SPEC-R12	<i>Removed issue 1.0</i>	
IRD-SPEC-R13	<i>Removed issue 1.0</i>	
IRD-SPEC-R14	Fringe contrast shall be greater than 80% for any point in the field of view for a resolution of 0.4 cm <sup>-1</sup> .	SRD R21
IRD-SPEC-R15	The spectrometer dynamic range for astronomical signals shall be 12 bits or higher	SRD R18
IRD-SPEC-R16	The FTS absolute photometric accuracy at the required resolution shall <15% at all wavelengths with a goal of <10%	SRD R19
IRD-SPEC-R17	The sensitivity of the FTS at any spectral resolution up to the goal value shall be limited by the photon noise from the Herschel telescope within the chosen passband	SRD R17



Project Document

**INSTRUMENT REQUIREMENTS  
DOCUMENT**

**Ref:** SPIRE-RAL-PRJ-000034

**Issue:** 1.3

**Date:** 14 July 2005

**Page:** Page 18 of 78

---

**Table 2.2-4: Summary of Spectrometer performance requirements from the SPIRE Science Requirements Document.**

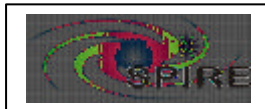

## 2.3 Instrument Operations Requirements

### 2.3.1 Instrument Operations

Requirement ID	Description	Source
IRD-OPS-R01	It shall be possible to calculate the execution time of an instrument command to within 1 sec (TBC). <i>This will allow the calculation of the time taken to execute any observation to be made, for example, when generating a timeline.</i>	HP-SPIRE-REQ-0190
IRD-OPS-R02	The instrument shall be capable of limiting the average data rate to the CDMS, during a 24hr period, to 130kbps. <i>This is primarily achieved by design of the nominal instrument observing modes to generate data at a rate that meets this requirement. However, the on-board software shall be required to provide for the selection of subsets of science data (i.e. selected pixels from a detector array).</i>	HP-SPIRE-REQ-0150
IRD-OPS-R03	The SPIRE instrument shall be identified as a single subsystem within the satellite. <i>That is, the instrument will utilise a single APID (to be defined by the Herschel Project) to identify both telecommands to the instrument and telemetry from the instrument.</i>	HP-SPIRE-REQ-0080
IRD-OPS-R04	The photometer observing modes should provide a mechanism for telemetering undifferenced samples to the ground	SRD R4
IRD-OPS-R05	The photometer should have an observing mode that permits accurate measurement of the point spread function	SRD R5
IRD-OPS-R06	The SPIRE photometer shall have an observing mode capable of implementing a 64-point jiggle map to produce a fully sampled image of a 4x4 arc minute region	SRD R23
IRD-OPS-R07	The photometer observing modes shall include provision for 5-point or 7-point jiggle maps for accurate point source photometry	SRD R24
IRD-OPS-R08	The photometer shall have a "peak-up" observing mode capable of being implemented without using satellite pointing	SRD R25

**Table 2.3-1: Requirements on the instrument operations**

### 2.3.2 Operating Modes

This section describes the expected operating modes for the SPIRE instrument.

Requirement ID	Description	Source
IRD-MODE-R01	The instrument shall be capable executing all operating modes described in the SPIRE Operating Modes Document (RD14)	Created

**Table 2.3-2: Requirements on the instrument operating modes.**

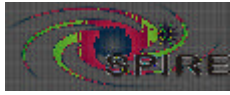

### 2.3.3 Commanding Requirements

Instrument operations will be controlled by commands passed from the CDMS to the instrument in the form of telecommand packets (see RD4). The CDMS will be responsible for handling the command timeline uplinked from the ground and issuing the commands to the instrument at the appropriate time. The instrument, therefore, is normally expected to execute the commands it receives from the CDMS (or CDMS simulator) in the order in which it receives them. Commands will be provided to modify the order of execution if required.

Requirement ID	Description	Source
IRD-CMD-R01	The instrument shall be capable of accepting telecommand packets from the CDMS at speeds up to the maximum rate delivered by the CDMS, without loss. <i>This implies that the instrument should be able to buffer a number of telecommands received from the CDMS while a command is being executed. However, it may be assumed that the timing of command distribution to the instrument will be managed so that the maximum number of commands in the buffer will be limited.</i>	HP-SPIRE-REQ-0210
IRD-CMD-R02	The instrument shall validate each telecommand packet as it is received. <i>Telecommand packets will contain a checksum to allow validation. Invalid commands should be rejected</i>	PSICD
IRD-CMD-R03	The instrument shall verify execution of the telecommands in each packet. <i>Normally, each telecommand packet will contain only one instrument command Commands which take a long time to execute (longer than ~5 sec) should have their progress verified also.</i>	PSICD
IRD-CMD-R04	The instrument shall report the result of all telecommand validation/verification in telemetry <i>The format of these telecommand report packets are defined in AD6</i>	PSICD
IRD-CMD-R05	The instrument shall provide commands to allow control of all individual devices (e.g. switch, latch) within the instrument.	Created
IRD-CMD-R06	All commands to individual devices shall explicitly set the state of the device <i>I.e. there shall be no commands to 'toggle' the state of a switch or commands to step to the next location.</i>	Created
IRD-CMD-R07	The action of all commands affecting an individual device shall	PSICD

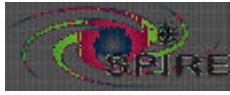

**INSTRUMENT REQUIREMENTS  
DOCUMENT**

Requirement ID	Description	Source
	be verifiable by an independent parameter available in the nominal housekeeping packet. <i>For example the change of state of a switch shall be verified by the change in voltage at the output of the switch rather than the status of the latch controlling the switch</i>	
IRD-CMD-R08	The instrument shall provide commands to execute the functions required to implement the instrument operating modes <i>These functions are defined in the SPIRE Operating Modes document (RD14). They usually invoke one or more device control actions in order to perform their function.</i>	Created
IRD-CMD-R09	The instrument shall provide the facility to define and execute procedure commands. <i>These commands will invoke stored sequences of commands with appropriate control steps to allow a given task to be performed. They will be invoked with supplied parameters to modify the actions performed. The intention is to minimise the number of telecommand words required to execute a given command sequence.</i>	Created
IRD-CMD-R10	The instrument shall provide commands to modify the execution sequence of commands. <i>Normally, commands are executed in the order in which they are received. These commands should provide the facility to interrupt the currently executing command, modify the command queue and continue execution of commands in the queue.</i>	Created
IRD-CMD-R11	The instrument shall provide commands to allow identification of the steps within an observation. <i>For processing of the data from the instrument it will be necessary to be able to identify the observation/step from which the data has come. These commands should modify software parameters onboard so that this information is reported in the telemetry</i>	Created
IRD-CMD-R12	The instrument shall provide commands to modify data values/tables held in the instrument memory. <i>The on-board software will use data tables to control the operations onboard. These tables may need to be maintained.</i>	<a href="#">IID-A-sect5.13.2.3</a>
IRD-CMD-R13	The instrument shall provide commands to enable on-board software maintenance <i>It should be possible to update the on-board software code either as a whole, or replace a single subroutine/function.</i>	<a href="#">IID-A-sect5.13.2.3</a>

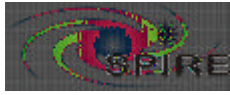
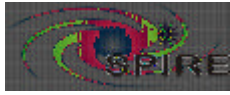

**Table 2.3-3: Instrument level requirements on telecommanding**

**2.3.4 Telemetry Requirements**

All data generated by the instrument will be transmitted from the instrument to the satellite CDMS in the form of telemetry packets. These packets will be store onboard by the CDMS, until the opportunity arises to transmit them to the ground.

<b>Requirement ID</b>	<b>Description</b>	<b>Source</b>
IRD-TLM-R01	The instrument shall be capable of transferring telemetry packets to the CDMS (or simulator) at up to the maximum rate allowed by the telemetry interface. <i>This is approximately 1Mbps</i>	IID-B HP-SPIRE-REQ-0160
IRD-TLM-R02	The instrument shall be able to buffer up to 10 seconds (TBC) worth of telemetry packets. <i>The CDMS will poll each subsystem on the satellite in turn for data. The instrument should be able to buffer sufficient packets to not lose data waiting for the CDMS.</i>	HP-SPIRE-REQ-0170
IRD-TLM-R03	It shall be possible to validate the content of each telemetry packet. <i>The telemetry packet standard identifies the location of a checksum of the data contained within the packet. This checksum may be used to validate the packet</i>	PSICD
IRD-TLM-R04	All telemetry packets shall contain information identifying the observation/step being executed. <i>This will allow data processing software to identify significant steps in an observation in order to apply the appropriate processing</i>	PSICD
IRD-TLM-R05	The instrument shall generate housekeeping data packets in all operating modes. <i>These data packets contain the values of both hardware and software parameters internal to the instrument.</i>	Created
IRD-TLM-R06	It shall be possible to define alternative housekeeping packet structures with different rates of generation. <i>The normal housekeeping packet will be generated once per second and contain, at the least, all hardware parameters. Housekeeping packets generated at higher rates (up to 500 per second) may contain a subset of the instrument parameters</i>	IID-A-sect5.11.1
IRD-TLM-R07	The instrument shall generate science data packets in all observing modes.	Created



Requirement ID	Description	Source
	<i>These packets shall contain data from the detector arrays associated with the observing mode, plus all instrument parameters that may be required to enable the processing of the detector data (e.g mechanism positions, temperatures of units which may affect the detector data, monitoring parameters for the subsystems being used).</i>	
IRD-TLM-R08	It shall be possible to define alternative science data packets structures. <i>This will allow the set of detector data and instrument parameters included in the science data to be optimised for different observation modes.</i>	Created
IRD-TLM-R09	The instrument shall generate event packets in all operating modes. <i>These packets notify the CDMS and/or ground monitoring equipment of instrument anomalies and significant actions taken by the instrument. The ESA packet Utilisation Standard identifies many of these report packet types. These packets should identify the type of anomaly and the data used to identify it.</i>	Created

**Table 2.3-4: Instrument level requirements on the data packets**

**2.3.5 Data Handling Requirements**

Requirement ID	Description	Source
IRD-DATA-R01	All data transferred between the CDMS and the instrument shall be contained in packets conforming to the Herschel/Planck PSICD (AD6) <i>It is assumed that in the interests of commonality with other spacecraft systems and scientific instruments the data handling of the SPIRE instrument will follow this standard. The detailed definition of the contents of each packet will formally be defined in a Herschel Space/Ground Interface Document to be written and agreed later.</i>	IID-A- sect5.11.1
IRD-DATA-R02	The instrument shall provide all mandatory packet handling services defined for the mission. <i>The OIRD (AD3) defines the list of mandatory services</i>	OIRD
IRD-DATA-R03	The instrument shall be capable of buffering up to 10 seconds of data generated during an observation. <i>It is possible that data will be generated during an observation, at a rate greater than that which can be instantly transferred to the CDMS. The instrument should buffer this data and transfer it to the CDMS at a later time (even if a new</i>	IID-B HP-SPIRE- REQ-0170

**INSTRUMENT REQUIREMENTS  
DOCUMENT**

	<i>observation has begun).</i>	
IRD-DATA-R04	<p>The instrument shall be capable of reducing the average data rate to the CDMS to 20kbps.</p> <p><i>This may be required to cope with a reduced telemetry downlink rate or 'partner mode' observations. The science content of the telemetry may be degraded.</i></p>	<a href="#">IID-A-sect5.11.1</a>
IRD-DATA-R05	<p>The packing of science data into science data packets shall minimise loss of information if packet is lost or corrupted.</p> <p><i>Science data packets could include data from one or more detectors over a given time period (or for a single interferogram) rather than one sample from all detectors. In this way if a data packet is lost the impact on the science is reduced.</i></p>	Created

**Table 2.3-5: Instrument level data handling requirements**



## 2.4 Instrument Model Philosophy

Note in version 1.2 – a waiver has been raised against this section to reflect changes in model philosophy made in order to fulfil delivery dates.

The instrument models to be built are as follows:

**AVM – Avionics Model.** This is an electrical model of the SPIRE instrument and will consist of the AVM DPU and a DRCU simulator. It will allow the electrical and software interfaces between the SPIRE instrument and the spacecraft to be validated. This will include the capability of testing the SPIRE autonomy functions and any exchange of information required between the spacecraft and SPIRE for any SPIRE operational mode. This model is delivered to ESA.

**STM – Structural Thermal Model.** This is a model of the cold FPU and JFET boxes that will be used to verify the vibration levels that will be experienced by the cold sub-systems during launch and to verify that the thermal design of the instrument meets the instrument level performance requirements. This model will consist of the CQM structure, thermal hardware and optics, the CQM cooler and mass/thermal models of the cold sub-systems. In order to test the real vibration levels and thermal environment that will be experienced at the sub-system interfaces it will be necessary to have some of the sub-system STMs as mechanically representative as possible although there is no requirement that they should actually function. The FPU harnesses for the cold sub-systems and between the JFET boxes and the FPU should also be present to allow early test of the integration procedures and environmental robustness of the harness design. This model will be vibrated to full qualification levels at ambient temperature and, if possible, at cryogenic temperature. The model will be placed in the instrument test cryostat and full thermal characterisation will be carried out. This model is not delivered to ESA.

**CQM - Cryogenic Qualification Model.** This is a model of the instrument that will be used to characterise and verify the instrument scientific performance with functionally representative cold sub-systems and warm electronics units. The structure, optics, cooler and FPU harnesses will be those used for the STM. All other cold FPU units need to function and have close to the expected flight performance, but do not need to be capable of withstanding the launch environment; have the full reliability and redundancy or necessarily be flight like in terms of power dissipation or speed of response. The purpose of the CQM is to verify that the design of the PFM will be capable of meeting the instrument level performance requirements and that the instrument is compatible with integration into the Herschel satellite. The requirements on the SPIRE CQM sub-systems will be judged against these criteria on a case by case basis.

This model is delivered to ESA.

**PFM – Proto-Flight Model.** This will be the instrument model that is intended for flight. It will be built to full flight. It will be the only fully integrated instrument model that has the full flight like performance characteristics. The PFM cold FPU and JFET boxes will therefore undergo environmental test to qualification levels for acceptance times (TBC). The SPIRE warm electronics units will have full qualification models built and tested, therefore the PFM warm electronics units will only undergo acceptance testing.

This model is delivered to ESA.



FS – Flight Spare. The flight spare cold FPU and JFET boxes will be constructed from the refurbished CQM (TBC). The flight spare warm electronics will consist of spare electronics cards.

<b>Requirement ID</b>	<b>Description</b>	<b>Source</b>
<b>IRD-INST-R14</b>	The SPIRE instrument shall provide the instrument models as specified	<a href="#">IID-B-sect5.16</a>

**Table 2.4-1: Instrument level model requirements.**

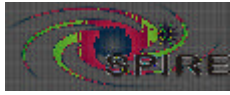

## 2.5 Instrument level Qualification

It is required that the instrument be qualified at unit level – i.e. the cold FPU; warm electronics boxes etc must undergo individual qualification testing and be shown to be flight worthy. The tests that are required for each model and unit are outlined in Table 2.5-1 and described in more detail in the SPIRE Instrument AIV Plan (RD9).

### Test Matrix

	STM Cold Focal Plane Units	CQM Cold Focal Plane Units	QM Warm Electronics Units	PFM Cold Focal Plane Units	PFM Warm Electronics Units	FS Cold Focal Plane Units	FS Warm Electronics Cards
Vibration:	Q	x	Q	QA	A	TBC	A
Thermal cycle:	Q	Q	Q	QA	A	TBC	A
Vacuum cycle	x	x	x	x	x	x	x
Thermal range:	x	x	x	x	x	-	-
EMC (Instrument Level)	x	x	x	x	x	-	-
EMC (Satellite Level):	-	-	-	x	x	-	-

**Table 2.5-1: Test matrix for the instrument level testing.**

Q indicates a test carried out at qualification level for qualification times; QA a test carried out at qualification levels for acceptance test times and A a test carried out at acceptance level for acceptance times. An x indicates that this test is carried out and is a characterisation type test or the level is irrelevant. A dash indicates that no test will be done on this model/unit.

Requirement ID	Description	Source
<b>IRD-INST-R15</b>	The instrument units are required to undergo an environmental test programme that demonstrates the design and build standard of the flight model is compatible with the launch and operational environment of the Herschel satellite.	<a href="#">IID-B-sect9</a>

**Table 2.5-1: Instrument level qualification requirements.**

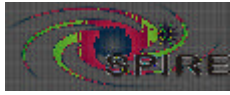

## 2.6 Verification

Note in version 1.2 – a waiver has been raised against this section to reflect changes in model philosophy made in order to fulfil delivery dates.

For the purposes of verification requirements, the instrument models consist of the units specified in section 2.4. It is also assumed that there will be present some form of EGSE to allow testing of the instrument models in the absence of the spacecraft and that there will be some computer hardware and software to allow the receipt; storage and analysis of the test data.

Requirement ID	Description	Source
IRD-VER-R01	<p>The STM verification testing shall demonstrate that the proposed structure design is capable of meeting the mechanical environmental conditions specified for the Herschel launch.</p> <p>The STM vibration shall be used to verify the stiffness and strength of the structure and verify the mechanical and thermal transfer functions between the various parts of the cold focal plane units and the Herschel satellite.</p>	<a href="#">IID-B-sect9</a>
IRD-VER-R02	<p>The AVM verification testing shall demonstrate that the instrument will fulfil the requirements on the following:</p> <p>Communication between the satellite CDMS and the DPU.</p> <p>Correct transfer and receipt of instrument commands from the satellite</p> <p>Correct transfer and receipt of instrument data packets from the instrument to the satellite</p> <p>Correct execution of instrument commands</p> <p>Correct transfer of instrument data from the FPU simulator to the DPU</p> <p>Correct execution of DPU on-board software for any data compression algorithms and packet generation for all instrument data packet types.</p>	<a href="#">IID-B-sect9</a>
IRD-VER-R03	<p>The CQM verification testing shall demonstrate that the following conditions are met or are likely to be met on the PFM:</p> <p>Correct operation of all FPU sub-systems at cryogenic temperatures for all instrument operation modes for both prime and redundant systems.</p> <p>The instrument cold FPU and JFET box thermal dissipation is within requirements for all instrument operation modes.</p> <p>The warm electronics thermal dissipation at room temperature is within requirements.</p> <p>Correct operation of all on-board software.</p> <p>The instrument straylight environment is within requirements</p> <p>The instrument optics performance is within requirements</p> <p>The performance of the instrument meets the scientific</p>	<a href="#">IID-B-sect9</a>





<b>Requirement ID</b>	<b>Description</b>	<b>Source</b>
	requirements expected for the CQM for all instrument observing modes Development and test of all functional test sequences required for Integrated Systems Testing (IST) at satellite level. The correct functioning of the instrument for all observing modes and calibration sequences. Development and test of all in-flight functional and performance test sequences	
<a href="#">IRD-VER-R04</a>	The PFM verification testing shall, in addition to the requirements on the CQM and AVM verification, demonstrate the following: The performance of the flight instrument meets the scientific requirements for all instrument observing modes. Correct operation of flight version of all on-board software. The characterisation of the PFM instrument performance for all instrument observing modes – including generation of data for instrument calibration and functional testing both during IST and in-flight. The characterisation of the instrument performance with the warm electronics operating over a range of temperatures Final test of all functional test sequences for IST. Final test of all observing modes Final test of all in-flight functional and performance test sequences.	<a href="#">IID-B-sect9</a>

**Table 2.6-1: Requirements on the instrument level verification.**

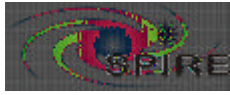

**2.7 Safety**

Requirement ID	Description	Source
IRD-SAFE-R01	During all mission phases, there shall be no requirement for commands to be sent from the ground to the instrument with an immediate response time (i.e. less than 2 minutes TBC). <i>Any such situations must be handled on board.</i>	OIRD-CTRL-1
IRD-SAFE-R02	Situations which require response from the ground within a short time (i.e. less than 30 mins) shall be reduced to a minimum, be well identified and agreed by ESA	OIRD-CTRL-2
IRD-SAFE-R03	Situations which require response from the ground within a short time (i.e. less than 30 mins) shall be unambiguously recognisable in the instrument housekeeping telemetry, without complex processing	OIRD-CTRL-3
IRD-SAFE-R04	Housekeeping telemetry shall be generated during all nominal modes of the instrument. <i>This includes any instrument Safe Modes</i>	OIRD-CTRL-4
IRD-SAFE-R05	The instrument shall be able to accept all telecommand packets sent to it at the nominal transfer rate from the CDMS	OIRD-CTRL-5 OIRD-CTRL-6
IRD-SAFE-R06	It shall not be possible by command, or lack of command, to place the instrument into a configuration that will, or is likely to cause damage to any subsystem	Created
IRD-SAFE-R07	All telecommands received by the instrument shall be checked to be correctly formatted and complete before execution. <i>Incorrect telecommands will be rejected by the instrument</i>	HP-SPIRE-REQ-0220
IRD-SAFE-R08	Failure of any sub-system, or one of its components, shall not affect the health of any other subsystem, the instrument or the interface with the satellite.	Created
IRD-SAFE-R09	Failure of any component in a subsystem shall not damage any redundant or backup component designed to replace that component in the subsystem	Created
IRD-SAFE-R10	No electronics sub-unit shall be capable of affecting instrument operations until it is in a defined state. This state shall be confirmed in the housekeeping telemetry.	Created
IRD-SAFE-R11	No commands shall be sent to an electronics sub-unit until they are in a defined state confirmed by the on-board software	Created

**Table 2.7-1: Instrument level safety requirements.**



## 2.8 Autonomy

The instrument is required to be “autonomous” when not in ground contact. This implies that the warm electronics must monitor critical housekeeping parameters to ensure that any sub-system failure is detected and the appropriate action taken. It is assumed that the basic action will be to switch the instrument to a safe mode with only the DPU on and housekeeping telemetry.

Requirement ID	Description	Source
IRD-AUT-R01	The SPIRE instrument shall have a defined safe mode. <i>The configuration of this mode shall be agreed with ESA</i>	<a href="#">IID-A-sect5.13.2.5</a>
IRD-AUT-R02	The SPIRE instrument shall define housekeeping parameters to be used for autonomous health and safety monitoring	Created
IRD-AUT-R03	The SPIRE instrument shall provide a method of monitoring the defined housekeeping parameters and taking appropriate action in the case of error or failure.	Created
IRD-AUT-R04	The SPIRE instrument shall provide a method of alerting the S/C CDMS of any failure requiring the instrument to be controlled by the CDMS (e.g. switched off ). <i>Actions to be taken in the case of failure will be defined by the instrument and stored as procedures in the CDMS</i>	<a href="#">HP-SPIRE-REQ-0220</a>
IRD-AUT-R05	The instrument shall continuously monitor the integrity of the on-board software and take appropriate action in case of error. <i>The on-board software can itself calculate a checksum over the OBS code and compare this to a stored value.</i>	Created
IRD-AUT-R06	The instrument shall monitor the operational status of the instrument on-board computers and take appropriate action in case of error. <i>A watchdog function will be implemented to identify if the on-board computer(s) have crashed.</i>	Created

**Table 2.8-1: Requirements for autonomous health and safety monitoring.**

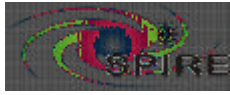

## 2.9 Reliability and Redundancy

It is assumed that reliability will be maintained by use of a combination of hardware redundancy and flexibility in the onboard software such that a failure of a single hardware device will not lead to a loss of instrument capability, although it may lead to loss of instrument performance.

Requirement ID	Description	Source
IRD-REL-R01	As far as possible the total failure of a single sub-system shall not lead to the total loss of instrument operations.	Created
IRD-REL-R02	Backup modes of operation should be available for all nominal observing modes. These shall be designed to allow the continued use of that mode, albeit with degraded performance or efficiency.	Created
IRD-REL-R03	Cold redundant hardware shall be provided wherever practicable within the instrument design.	Created
IRD-REL-R04	As far as possible all control loops shall be implemented through the use of on-board software.	Created
IRD-REL-R05	It shall be possible to break all control loops implemented in hardware. <i>This will allow the control of the loop through the on board software (this may be a degraded mode of operation)</i>	Created

**Table 2.9-1: Instrument level reliability and redundancy requirements.**



## 2.10 EMC

Protecting the bolometer system from EMI disturbance is critical to the performance of the SPIRE instrument. The philosophy for the grounding and RF protection of the detectors is briefly given here for information and is formulated from the warm electronics “towards” the instrument FPU.

The HSDPU shall be a conventional secondary power driven unit, locally grounded and self contained

The HSFCU shall be similar except that it interfaces to non-bolometer sub-systems in the HSFPU which are electrically isolated from the HSFPU except for 2200pF pi filters on each wire entry contact. This means that in order not to drive noise into the HSFPU box, all these HSFCU drives shall be balanced. The HSFCU shall also source isolated secondary voltages to the HSDCU.

The HSDCU shall have redundant digital sections locally grounded as in the DPU. These will digitally interface to the HSDPU but are powered from the HSFCU. The HSDCU shall also have a very low noise analogue system to be able to handle the bolometer signals, i.e. low power supply noise, low ground noise and low r.f. e.m.c. noise, in both differential and common mode.

The HSFPU and JFET racks shall form an isolated Faraday cage around the detectors, with all bolometer signal wires entering or leaving it filtered at the JFET racks via 6700pF pi filters on each wire contact.

The analogue ground for the detection system is split into photometer and spectrometer branches because physical routing causes them to be separated via different JFET racks which would otherwise cause a major ground loop at a sensitive point. These grounds join to two separate analogue grounds in the HSDCU. The 300mK detector sections are joined to this system, meaning that the electronics associated with the sorption cooler shall be particularly quiet and well isolated. The point where this analogue ground is joined to chassis will be proven by test. An initial choice will be made by modelling between placing the star point in the HSDCU; in the JFET filters or in the 2K detector boxes.

Requirement ID	Description	Source
<a href="#">IRD-EMC-R01</a>	The Spire instrument grounding shall comply with the Spire Instrument Grounding Philosophy document (RD13).	<a href="#">IID-B-sect5.10.2</a>



### 3. SUBSYSTEMS REQUIREMENTS

#### 3.1 Assumptions

The SPIRE instrument will consist of the sub-systems indicated in figure 3.1-1 and table 3.1-1. Figure 3.1-1 also shows the interface relationship between the SPIRE sub-systems; harnesses etc.

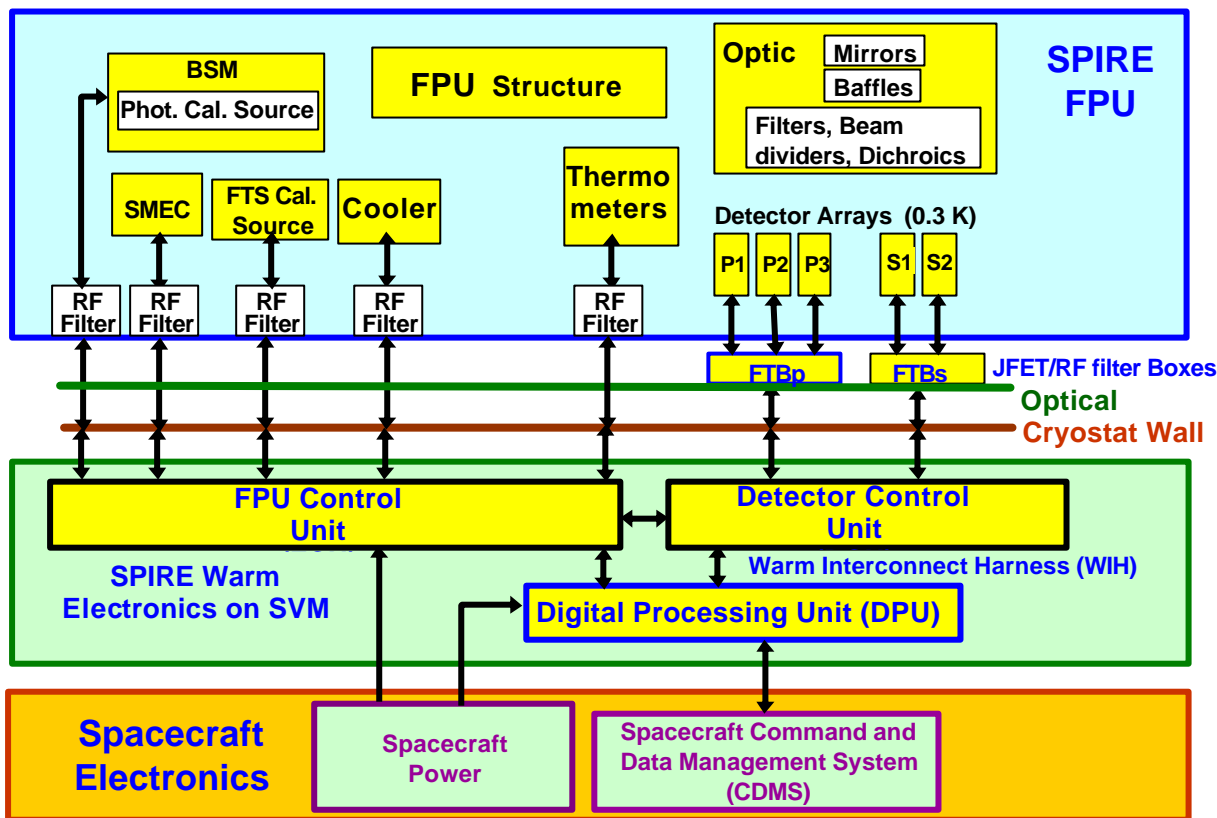
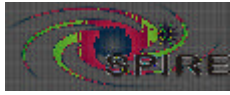

Figure 3.1-1: SPIRE sub-system block diagram

Subsystem Name	Description	Unit	Number
Structure	Focal plane unit structure to hold all cold sub-systems in the focal unit. This includes all thermometers necessary to monitor the instrument during cool down and operation.	HSFPU	1.1
Optics	All mirrors for the photometer and spectrometer channels	HSFPU	1.2
Filters	All filters; beam splitters and dichroics for the photometer and spectrometer channels The requirements on these are included with those for the optics.	HSFPU	1.2.1
Baffles	Straylight control baffles for the photometer and spectrometer channels	HSFPU	1.2.2
Cooler	<sup>3</sup> He cooler unit cools the photometer and spectrometer detector arrays to 300 mK	HSFPU	1.3
Detector Arrays	Bolometer array modules for the photometer and	HSFPU	1.4



**INSTRUMENT REQUIREMENTS  
DOCUMENT**

	spectrometer		
Beam Steering Mechanism	This mechanism allows the photometer and spectrometer fields of view to be stepped or chopped across the sky.	HSFPU	1.5.1
FTS Mechanism (SMECm)	The FTS moving mirrors drive mechanism and position measurement system. SMECm designates the mechanism and position encoder	HSFPU	1.5.2
FTS encoder amplifier (SMECp)	SMECp the cold pre-amplifier that may be required for the encoder detectors.	HSFPU	1.5.3
Shutter Mechanism Deleted v1.2			
Photometer Calibration Source	Calibration source for photometer	HSFPU	1.6.1
Spectrometer Calibration Source	Calibration source for the spectrometer	HSFPU	1.6.2
RF Filter Modules	Each sub-system harness into the cold FPU must have an electrical RF filter to prevent EMI problems with the bolometers. These will be mounted in standard RF filter modules on the wall of the FPU box.	HSFPU	1.7
Photometer JFET Box	JFET pre-amplifiers for photometer NTD germanium bolometers.	HSFTBp	1.8.1
Spectrometer JFET Box	JFET pre-amplifiers for spectrometer NTD germanium bolometers.	HSFTBs	1.8.2
Detector Read-out & Control Unit	Detector amplifier and digitisation chain and instrument control electronics. Conceptually this is a single unit – as indicated in figure 3.1-1 – however for accommodation reasons it will be split into two physical units	HSDRC	2.2
Focal Plane Control Unit	Contains the electronics for the power conversion and distribution to the DRCU; for the control and read-out of the thermometers; cooler; calibration sources (Subsystem Control Unit (SCU)) and the cold mechanisms (Mechanism Control Unit (MCU))	HSFCU	2.2.1
Detector Control Unit	Contains the bias conditioning electronics for the bolometers arrays and JFET units and the lock in amplifiers and readout electronics for all the detector arrays.	HSDCU	2.2.2
Digital Processing Unit	Instrument on board computer – forms interface to CDMS	HSDPU	2.3
Warm Interconnect Harness	Harness between warm boxes	HSWIH	2.4
On Board Software	All on board software that controls the function of the instrument. This is all contained in the DPU	HSOBS	2.5
FPU Simulator	A set of electronic components, either passive or active, that mimics the analogue response of the FPU sub-systems to the warm electronics.	HSFPS	3.1
DRCU Simulator	A set of interface hardware and computer software that	HSDRS	3.2

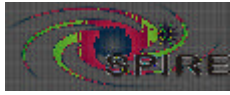

**INSTRUMENT REQUIREMENTS  
DOCUMENT**

	mimics the response of the DRCU and FPU to the DPU and on board software.		
--	---	--	--

**Table 3.1-1: Listing of SPIRE sub-systems.**

The unit column refers to the ESA designation for the unit in which the sub-system is located. The sub-system number is that allocated for the purposes of interface control.

**3.2 Scope**

This chapter details the requirements on the cold focal plane unit sub-systems; the JFET box and the instrument simulators.

**3.3 Subsystem Qualification Requirements**

**Assumptions**

It is assumed that all sub-systems will have been through a qualification programme of one or more models before the Proto-flight version of the sub-system is delivered for the instrument AIV. This implies:

1. Any testing carried out on the STM and CQM instruments should **NOT** be considered to be the qualification test for each individual sub-system. The tests carried out on the instrument will be neither exhaustive nor at the correct level for sub-system qualification.
2. It is intended that the tests listed here be carried out on a specific qualification model. It is expected that acceptance tests will be done on each delivered model (Proto-Flight and Flight Spare) as part of the general instrument AIV – these will be detailed in the instrument AIV plan. The qualification test programme does not replace the need for acceptance testing of each model.

**Test Matrix:**

	Structure	Optics	FTS Mechanism		BSM	Detector arrays	Cooler	Filters/grids/dichroics	Calibration Sources	DRCU	DPU
Vibration:	X	X	X		X	X	X	X	X	X	X
Thermal cycle:	X	X	X		X	X	X	X	X		
Vacuum cycle			X		X	X	X	X	X	X	X
Lifetime:		P	X		X	X	X	X	X	X	X
Soak/cycle:			X		X	X	X		X	X	X
Radiation tolerance:			P		P	X	P	X	X	X	X
Thermal range:			X		X	X	X	X	X	X	X
Thermal stability:		P	X		X	X	X	P	X	X	X
Microphonics:		P	X		X	X	X	P	P		
Ionising radiation:						X					





EMI:			X		X	X	P		P	X	X
EMC:			X		X	X	P		P	X	X

**Table 3.3-1: Test matrix for the SPIRE sub-systems qualification programme.**

Tests marked with an X are mandatory, those marked with a P are possibly required depending on the detailed design of the sub-system and/or the new of novel materials. A full description of each test is given in the SPIRE Instrument AIV Plan (RD9). For some sub-systems the qualification and lifetime testing will be more appropriately carried out at component or test item level rather than at the level of the integrated sub-system. At what stage and under what conditions the tests are to be carried out is a matter for detailed consideration by the groups responsible for the sub-systems delivery.

Requirement ID	Description	Source
<b>IRD-SUBS-R01</b>	All subsystems are required to undergo an environmental test programme that demonstrates the design and build standard of the sub-system models will be compatible with the environmental test programme to be carried out on the appropriate integrated instrument model.	Created
<b>IRD-SUBS-R02</b>	All sub-systems are required to demonstrate that they will operate successfully over the 4.25 years of expected mission operations following launch.	Created

### 3.4 Assumptions for the Focal Plane Unit

#### 3.4.1 Plate Scale

The nominal optical design of the SPIRE optics for both the photometer and spectrometer has a final focal ratio onto the detectors of f/5. This implies, given the design of the Herschel telescope (see section 2.1.4.4), that the nominal plate scale at the SPIRE focal plane is 12.564 arcsec/mm. This value will be used throughout this section to determine the required size of the focal plane arrays.

#### 3.4.2 Vacuum

The cold focal plane unit will be launched and operated in a vacuum of  $<10^{-3}$  mBar.

#### 3.4.3 Mass

Requirements are not directly placed on the mass of each sub-system in this document (issue 3) as this is felt to be unnecessarily prescriptive. However, the mass of the focal plane units is of deep concern and all sub-systems are required to be as mass efficient as possible. A mass allocation for each sub-system is set out in RD8..

Requirement ID	Description	Source
<b>IRD-SUBS-R03</b>	All subsystems are required to be within the mass allocation given in RD8	<a href="#">IID-B-sect5.5</a>



### 3.5 Cold Units Sub-system requirements

#### 3.5.1 Structure

##### 3.5.1.1 Common Structure

###### Performance Requirements

Requirement ID	Description	Value	Source
IRD-STRC-R01	Alignment of the instrument w.r.t. the Herschel optical axis	The SPIRE common structure shall allow the alignment of the instrument and telescope optical axes to within $\pm 2.6$ mm lateral and $\pm 3.5$ arcmin rotational about any axis.	<a href="#">IID-A-sect5.3.2.1</a>
IRD-STRC-R02	Attenuation of RF by Common Structure covers	All joints of the external covers shall form EMC tight joints via the use of a stepped interface and a bolt spacing of no more than 30 mm. This is deemed sufficient for EMC tightness and no o-ring type seal is required	Created
IRD-STRC-R03	Items requiring support from the Common Structure	<b>Photometer and common sub-systems</b> Photometer optics Photometer filters Level 1 Thermal Strap Level 0 Thermal Straps <sup>3</sup> He Cooler Optical Baffles All sub-system harnesses BSM Mechanism and structure Photometer 2-K enclosure <b>Spectrometer</b> Spectrometer optics Beam splitters Mirror Mechanism (SMEC) Calibration source and mount Spectrometer detector box	Created
IRD-STRC-R04	Optics and associated sub-system alignment	The common structure shall be capable of maintaining the alignment of the photometer and spectrometer optics and associated components (i.e. filters; detector boxes; BSM etc) to within the specifications given in RD5 both at room temperature; during cryogenic operation and following launch	Created
IRD-STRC-R05	Surface finish of the Common Structure cover	The inside and outside of the box shall have a finish with a low emissivity. At least $\epsilon=0.2$ . Some parts of the structure walls may be blackened as part of the straylight control.	<a href="#">Upper link in RD15</a>



Requirement ID	Description	Value	Source
IRD-STRC-R06	Pumping port	The total effective pumping conductance of the common structure enclosure must be greater than or equal to 7.8 l/s	Created
IRD-STRC-R07	Thermometry	The structure subsystem shall provide thermistors and associated wiring to allow the temperature of critical parts to be monitored during in-flight operations – see section 3.5.12	Created
IRD-STRC-R08	Attenuation of radiation from cryostat environment	Requirement $<2 \times 10^{-5}$ To illustrate this, the requirement is the equivalent of a ~4 mm diameter hole in a total area of the box cover of 1 m <sup>2</sup> .	IRD-PHOT-04 IRD-PHOT-05 IRD-SPEC-R17

**Table 3.5-1: Performance requirements for the instrument common structural elements.**

**System Requirements**

Requirement ID	Description	Value	Source
IRD-STRC-R09	First natural frequency of the instrument assembly	The first eigenfrequency of the integrated instrument assembly shall be greater than 100 Hz with a goal of greater than 120 Hz	IID-A-sect9.4.1.2.5
IRD-STRC-R10	Instrument mechanical interface	The mechanical interface of the instrument will be directly to the Herschel optical bench and the instrument will be in direct thermal contact at that interface. The interface shall meet all requirements set out in AD1	IID-A-sect5.6.1
IRD-STRC-R12	Grounding	All parts of the SPIRE common structure shall be electrically connected one to another. Resistance to be no more than 0.1 Ω between any two parts of the structure	IRD-EMC-R01
IRD-STRC-R13	Electrical isolation from Herschel	All parts of the SPIRE structure shall be electrically isolated from the Herschel optical bench and cryostat. Resistance to be greater than 5 MΩ.	IRD-EMC-R01
IRD-STRC-R14	Thermal isolation	The conductance from the level 2 to level 1 stage shall be within the specification given in RD15.	IID-B-sect5.9.1
IRD-STRC-R13	SOB Temperature	The SPIRE Optical Bench shall be connected to the L1 stage with a thermal conductance meeting the requirements in RD15	IID-B-sect5.9.1

**Table 3.5-2: System requirements on the instrument common structural elements**



### 3.5.1.2 Photometer Structure

#### Performance Requirements

Requirement ID	Description	Value	Source
IRD-STRP-R01	Items requiring support	The photometer detector box shall support: Photometer optics; dichroics and filters Detector array modules; Detector thermal straps	Created
IRD-STRP-R02	Optics and filters alignment	The photometer detector box shall be capable of maintaining the alignment of the photometer optics; filters and dichroics to within the requirements set out in RD5 at room temperature; during cryogenic operation and following launch	Created
IRD-STRP-R03	Array module alignment	The photometer detector box shall be capable of maintaining the position of the detector array modules to within the requirements set out in RD5 about any axis during cryogenic operation of the instrument and following launch.	IRD-PHOT-R16
IRD-STRP-R04	Surface finish	The outside of the box shall have a finish with a low emissivity. At least $\epsilon=0.2$ The inside of the box shall have a low reflectivity finish on all non-optical surfaces.	<a href="#">Upper link in RD15</a>
IRD-STRP-R05	Pumping port	The total effective pumping conductance of the photometer detector box must be greater than or equal to 5.6 l/s	Created
IRD-STRP-R06	Attenuation of radiation from common structure environment	Requirement $5 \times 10^{-7}$ ; goal is $5 \times 10^{-8}$ (TBC) To illustrate this, the requirement is the equivalent of a 0.5 mm diameter hole in a total area of the box cover of $0.5 \text{ m}^2$ <i>This, of course, excludes the hole that lets the beam in.</i>	IRD-PHOT-R04 IRD-PHOT-R05

**Table 3.5-3: Performance requirements on the photometer detector box.**

#### System Requirements

Requirement ID	Description	Value	Source
IRD-STRP-R07	First natural frequency	The first eigenfrequency of the photometer detector box on its mounts shall be greater than 100 Hz with a goal of > 150 Hz	IRD-STRC-R09
IRD-STRP-R09	Thermal isolation	The conductance along the photometer detector box mechanical support from level 1 to level 0 shall be within the specification set in RD15	IID-B-sect5.9.1
IRD-STRP-R10	Photometer Box Temperature	The photometer box shall be connected to the cryostat L0 stage with a strap meeting the	IID-B-sect5.9.1



		conductance requirements in RD15	
<a href="#">IRD-STRP-R11</a>	Photometer Box Electrical isolation	All parts of the photometer box shall be electrically isolated from the SPIRE optical bench; the spectrometer box and the Herschel cryostat. Resistance to be greater than 5 MΩ.	<a href="#">IRD-EMC-R01</a>

**Table 3.5-4: System requirements on the photometer 2-K structure**

### 3.5.1.3 Spectrometer Structure

#### Performance Requirements

Requirement ID	Description	Value	Source
<a href="#">IRD-STRS-R01</a>	Items requiring support	The spectrometer detector box shall support spectrometer cold filters; spectrometer optics and spectrometer detector modules.	Created
<a href="#">IRD-STRS-R02</a>	Optics alignment requirements	The spectrometer detector boxes shall be capable of maintaining the alignment of the spectrometer optical components to within the requirements set out in RD5	Created
<a href="#">IRD-STRS-R03</a>	Array module alignment	The spectrometer detector box shall be capable of maintaining the position of the detector array modules to within the requirements set out in RD5 about any axis during cryogenic operation of the instrument and following launch	Created
<a href="#">IRD-STRS-R04</a>	Surface finish	The outside of the box shall have a finish with a low emissivity. At least $\epsilon=0.2$ The inside of the box shall have a low reflectivity finish on all non-optical surfaces.	<a href="#">Upper link in RD15?</a>
<a href="#">IRD-STRS-R05</a>	Pumping port	The total effective pumping conductance of the spectrometer detector box must be greater than or equal to 5.6 l/s	Created
<a href="#">IRD-STRS-R06</a>	Attenuation of radiation from 4-K environment	Requirement $5 \times 10^{-7}$ ; goal is $5 \times 10^{-8}$ (TBC) To illustrate this, the requirement is the equivalent of a 0.5 mm diameter hole in a total area of the box cover of 0.5 m <sup>2</sup> <i>This, of course, excludes the holes that let the beams in.</i>	<a href="#">IRD-SPEC-R17</a>

**Table 3.5-5: Performance requirements on the spectrometer detector box.**

#### System Requirements

Requirement ID	Description	Value	Source
<a href="#">IRD-STRS-R07</a>	First natural frequency	The first eigenfrequency of the spectrometer detector box on its mounts shall be greater than 100 Hz (TBC) with a goal of > 150 Hz	<a href="#">IRD-STRC-R09</a>

**INSTRUMENT REQUIREMENTS  
DOCUMENT**

<a href="#">IRD-STRS-R08</a>	Thermal isolation	The conductance along the spectrometer detector box mechanical support from level 1 to level 0 shall be within the specification set in RD15	<a href="#">IID-B-sect5.9.1</a>
<a href="#">IRD-STRS-R09</a>	Spectrometer Box Temperature	The spectrometer box shall be connected to the cryostat L0 stage with a strap meeting the conductance requirements in RD15	<a href="#">IID-B-sect5.9.1</a>
<a href="#">IRD-STRP-R10</a>	Spectrometer Box Electrical isolation	All parts of the spectrometer box shall be electrically isolated from the SPIRE optical bench; the spectrometer box and the Herschel cryostat. Resistance to be greater than 5 M $\Omega$ .	<a href="#">IRD-EMC-R01</a>

**Table 3.5-6: System requirements on the spectrometer detector box.**



### 3.5.2 <sup>3</sup>He Cooler and 300 mK architecture

#### Performance Requirements

These performance requirements are set to allow the top level performance requirements of the photometer and spectrometer to be met.

Requirement ID	Description	Value	Source
IRD-COOL-R01	Temperature at the detectors	The <sup>3</sup> He cooler, in conjunction with the associated 300 mK architecture, shall maintain all bolometer detector assemblies at less than 310 mK – goal 300 mK.	IRD-PHOT-R04 IRD-PHOT-R05 IRD-SPEC-R06 IRD-SPEC-R07
IRD-COOL-R02	Operating temperature control	Desirable to be able to vary the temperature of the detectors up to 320 mK and below 300 mK <i>if this is permitted by the temperature drop across the thermal link.</i> <i>The evaporator cold tip temperature can be varied by heating the sorption cooler.</i> <i>Electronic control shall be provided to do this in the flight electronics.</i>	Created
IRD-COOL-R03	Temperature drop across thermal link between detectors and evaporator cold tip	Maximum of 20 mK	IRD-COOL-R01
IRD-COOL-R04	Temperature drift	The temperature of the evaporator cold tip should not drift by more than 0.1 mK/h under active temperature control.	IRD-PHOT-R05
IRD-COOL-R05	Temperature fluctuations at the evaporator cold tip	10 μK Hz <sup>-1/2</sup> in a 0.1-10 Hz band <i>Assumes the 300 mK architecture and detector structures form a low pass thermal filter</i>	IRD-PHOT-R04 IRD-PHOT-R05 IRD-SPEC-R06 IRD-SPEC-R07
IRD-COOL-R06	System low frequency temperature stability	<i>Removed issue 1.0 – it is assumed that this is achieved with a low pass thermal filter</i>	
IRD-COOL-R07	Heat lift at evaporator cold tip	Minimum of 10 μW at 290 mK	Created
IRD-COOL-R08	Hold time	Minimum 46 hours	IID-A- sect5.13.2.5
IRD-COOL-R09	Recycle time	Maximum 2 hours	IID-A- sect5.13.2.5

**Table 3.5-7: Performance requirements on the sorption cooler.**



**System Requirements**

<b>Requirement ID</b>	<b>Description</b>	<b>Value</b>	<b>Source</b>
IRD-COOL-R10	Mechanical interface	Preferred interface is with the instrument common structure	Created
IRD-COOL-R11	Thermal Interface with Herschel cryostat	L0 cryostat stage for both sorption pump and evaporator. The interface shall meet the requirements in RD15	<a href="#">IID-B-sect5.9.1</a>
IRD-COOL-R12	Parasitic thermal load onto He bath during cold operation	The conducted load from level 1 to level 0 during cold operation shall be within the specification given in RD15	<a href="#">IID-B-sect5.9.1</a>
IRD-COOL-R13	Time averaged thermal load onto He bath for 48 hour cycle	The average load over the operational cycle shall be within the specification given in RD15	<a href="#">IID-B-sect5.9.1</a>
IRD-COOL-R15	Maximum envelope	200x100x100 mm	Created
IRD-COOL-R17	Sorption pump heater	<i>Removed issue 1.0</i>	
IRD-COOL-R18	Thermometers	Thermometers shall be provided on the cooler as necessary to monitor its behaviour and operation (see section 3.5.12). The absolute temperature measurement on the evaporator cold tip shall be 1% (<3 mK) with a resolution of 1 mK	Created
IRD-COOL-R19	Gas gap heat switches	It is noted that these are a potential single point failure in the instrument operation. Provision of some redundancy (i.e. doubling them up) is desirable <i>but not at the expense of severe limitations on the cooler performance.</i>	Created
IRD-COOL-R20	Ground Operation	The cooler must be capable of full operation on the ground, including recycling, when the instrument is in its normal orientation in the test facility. This will be arranged so that the evaporator is below the pump. The cooler must be capable of operating with the instrument rotated to up to 90° about either the S/C Y or Z axes.	Created
IRD-COOL-R21	Warm electronics power dissipation	<i>Removed issue 1.0 – see warm electronics requirements</i>	

**Table 3.5-8: Systems requirements on the sorption cooler**





Project Document

**INSTRUMENT REQUIREMENTS  
DOCUMENT**

**Ref:** SPIRE-RAL-PRJ-  
000034

**Issue:** 1.3

**Date:** 14 July 2005

**Page:** Page 45 of 78

### 3.5.3 Shutter

Version 1.1 All requirements renumbered as in [HR-SP-CSA-ECR-1](#)

Version 1.2 entire section deleted together with the shutter!

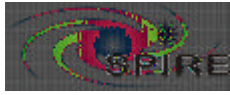

### 3.5.4 Harness

#### Performance Requirements

Requirement ID	Description	Value	Source
<a href="#">IRD-FPHR-R01</a>	Detector harness capacitance	The wire-to-wire capacitance of the cables running from the detector arrays to the JFET modules will be < 50 pF	<a href="#">IRD-PHOT-R04</a> <a href="#">IRD-PHOT-R05</a> <a href="#">IRD-SPEC-R06</a> <a href="#">IRD-SPEC-R07</a>
<a href="#">IRD-FPHR-R02</a>	Detector harness mechanical support	The detector harness cables routed inside the structure shall be affixed to have a mechanical resonant frequency > 1 kHz	<a href="#">IRD-PHOT-R04</a> <a href="#">IRD-PHOT-R05</a> <a href="#">IRD-SPEC-R06</a> <a href="#">IRD-SPEC-R07</a>

**Table 3.5-11: Detector harness requirements**

#### System Requirements

Requirement ID	Description	Value	Source
<a href="#">IRD-FPHR-R03</a>	Generic implementation	All sub-system electrical connections shall be routed through an RF filter module mounted on the outside cover of the FPU. The detector harnesses will be routed through the JFET boxes which will form part of the Faraday cage.	<a href="#">IRD-EMC-R01</a>

**Table 3.5-9: Requirements for the internal SPIRE harnesses.**



### 3.5.5 Optics and Filters

#### 3.5.5.1 Photometer Optics and Filters

##### Performance Requirements

These requirements are set to allow the top level performance requirements of the photometer to be achieved

Requirement ID	Description	Value	Source
IRD-OPTP-R00	Compatibility with Herschel telescope	The optical design of the photometer fore-optics shall be compatible with the Herschel telescope optical design.	<a href="#">IID-A-sect4.3.1</a>
IRD-OPTP-R01	Nominal final focal ratio	As close to F/5 as practical	Created
IRD-OPTP-R02	Variation in focal ratio	The focal ratio at any point in the must be within 20% of that of the on-axis point.	<a href="#">IRD-PHOT-R10</a>
IRD-OPTP-R03	Distortion	The image of the telescope field of view is nominally rectangular. The position of any point within the image of the FOV at the detectors must be within 10% of the actual position of the point at the telescope focal plane.	<a href="#">IRD-PHOT-R10</a>
IRD-OPTP-R04	Anamorphism	The anamorphic ratio of the image of a point source at the detectors must be no more than 6:5 in any pair of orthogonal directions at any point in the FOV.	<a href="#">IRD-PHOT-R03</a>
IRD-OPTP-R05	Throughput	The throughput of the photometer mirrors, filters, dichroics and baffles shall be greater than 0.27 over the instrument waveband. This includes losses due to manufacturing defects; surface finish and alignment tolerances.	<a href="#">IRD-PHOT-R04</a> <a href="#">IRD-PHOT-R05</a>
IRD-OPTP-R06	Image quality	The photometer optics shall give a Strehl ratio of greater than 0.9 over the full FOV at 250 $\mu\text{m}$ including all losses due to alignment; mirror quality etc	<a href="#">IRD-PHOT-R03</a> <a href="#">IRD-PHOT-R04</a> <a href="#">IRD-PHOT-R05</a>
IRD-OPTP-R07	Out of band radiation	The end to end filtering of the photometer shall control the out of band radiation to be no more than $10^{-3}$ for 40 $\text{cm}^{-1}$ to 200 $\text{cm}^{-1}$ $10^{-6}$ for 200 $\text{cm}^{-1}$ to 1000 $\text{cm}^{-1}$ $10^{-9}$ for 1000 $\text{cm}^{-1}$ to 100000 $\text{cm}^{-1}$ of the in-band telescope background radiation.	<a href="#">IRD-PHOT-R04</a> <a href="#">IRD-PHOT-R05</a>
IRD-OPTP-R08	In-band straylight	The background power falling on the detectors with the optical beam blocked shall	<a href="#">IRD-PHOT-R04</a> <a href="#">IRD-PHOT-R05</a> <a href="#">IRD-PHOT-R14</a>



Requirement ID	Description	Value	Source
		be no more than 5% of the in-band background power from the telescope over the 200-300 $\mu\text{m}$ band; 5% over the 300-400 $\mu\text{m}$ band and 5% over the 400-670 $\mu\text{m}$ band.	

**Table 3.5-10: Performance requirements on the photometer optics.**

### 3.5.5.2 Spectrometer Optics and Filters

#### Performance requirement

These requirements are set to allow the top level performance requirements of the spectrometer to be achieved

Requirement ID	Description	Value	Source
IRD-OPTS-R01	Nominal final focal ratio	As close to F/5 as practical	Created
IRD-OPTS-R02	Variation in focal ratio	The focal ratio at any point in the must be within 20% of that of the on-axis point.	Created
IRD-OPTS-R03	Distortion	The position of any point within the image of the FOV at the detectors must be within 10% of the actual position of the point at the telescope focal plane.	Created
IRD-OPTS-R04	Anamorphism	The anamorphic ratio of the image of a point source at the detectors must be no more than 6:5 (TBC) in any pair of orthogonal directions.	IRD-SPEC-R05
IRD-OPTS-R05	Theoretical throughput	The theoretical throughput of the spectrometer mirrors; filters; beam splitters and baffles shall be greater than 0.2 over the total instrument waveband including all losses due to manufacturing defects; surface finish and alignment tolerances.	IRD-SPEC-R06 IRD-SPEC-R07
IRD-OPTS-R06	Image quality	The spectrometer optics shall give a Strehl ratio of greater than 0.9 over the as much of the FOV as possible at 250 $\mu\text{m}$ including all losses due to alignment; mirror quality etc	IRD-SPEC-R05 IRD-SPEC-R06 IRD-SPEC-R07
IRD-OPTS-R07	Balancing of ports	In order that the two output ports shall have the same performance and to facilitate accurate compensation of the zero path difference maximum, the beam splitters shall have $2RT$ equal to $R^2+T^2$ to within 90% over the waveband of the instrument.	IRD-SPEC-R06 IRD-SPEC-R07 IRD-SPEC-R14
IRD-OPTS-R08	Out of band radiation	The end-to-end filtering of the spectrometer shall control the out of band radiation to be no more than $10^{-3}$ for 40 $\text{cm}^{-1}$ to 200 $\text{cm}^{-1}$	IRD-SPEC-R06 IRD-SPEC-R07

**INSTRUMENT REQUIREMENTS  
DOCUMENT**

Requirement ID	Description	Value	Source
		$10^{-6}$ for 200 cm <sup>-1</sup> to 1000 cm <sup>-1</sup> $10^{-9}$ for 1000 cm <sup>-1</sup> to 100000 cm <sup>-1</sup> of the in band telescope background radiation.	
IRD-OPTS-R09	In band straylight	The background power falling on the detectors with the optical beam blocked shall be no more than 5% of the in band background power from the telescope over the 200-400 $\mu$ m band and 5% over the 400-670 $\mu$ m band.	<a href="#">IRD-SPEC-R06</a> <a href="#">IRD-SPEC-R07</a> <a href="#">IRD-SPEC-R16</a>
IRD-OPTS-R10	Off axis resolution	The FWHM of the resolution element at any point in the FOV shall be no more than 10% greater than the on-axis value for a nominal resolution of 0.4 cm <sup>-1</sup> .	<a href="#">IRD-SPEC-R11</a> <a href="#">IRD-SPEC-R14</a>

**Table 3.5-11: Performance requirements for the spectrometer optics.**



### 3.5.6 Detectors

#### 3.5.6.1 Photometer Detectors

##### Performance Requirements

These requirements are set to allow the top level performance requirements of the photometer to be achieved

Requirement ID	Description	Value	Source
IRD-DETP-R01	Detective Quantum Efficiency at 2 Hz at nominal incident power levels	> 0.6	IRD-PHOT-R04 IRD-PHOT-R05
IRD-DETP-R02	Time constant	16 milliseconds (Equivalent to 10 Hz)	IRD-PHOT-R06
IRD-DETP-R03	Uniformity	NEP spec. shall be met over the whole array Responsivity variations shall be less than 10% across the array and calibrated to an accuracy of <1%	IRD-PHOT-R12
IRD-DETP-R04	Yield (good pixels)	≥90% for each array	IRD-PHOT-R04 IRD-PHOT-R05
IRD-DETP-R05	Electrical crosstalk for near neighbour pixels.	Requirement is less than 1% with a goal to be less than the optical cross talk at the output of the cold JFET amplifiers.	IRD-PHOT-R11
IRD-DETP-R06	Electrical crosstalk any pair of pixels	Requirement is less than 0.1% at the output of the cold JFET preamplifiers. Goal is to be less than the optical cross talk.	IRD-PHOT-R11
IRD-DETP-R07	Detector angular response	2Fλ Feedhorns : Single moded	IRD-PHOT-R06
IRD-DETP-R08	Spectral response	≥ 90% at the nominal edge frequencies of the appropriate passband	Created

**Table 3.5-12: Performance requirements on the photometer detectors.**

##### System Requirements

Requirement ID	Description	Value	Source
IRD-DETP-R09	Microphonic susceptibility	The design of the detector structural support and the detector harnessing shall be such as to minimise the impact of any microvibration induced in the instrument by internal or external sources	IRD-PHOT-R04 IRD-PHOT-R05
IRD-DETP-R10	EMI susceptibility	The design of any harnesses associated with the detectors that form part of the instrument RF shield shall be such as to minimise the influence of any potential EMI. All metalwork surrounding the detectors at 300 mK is electrically isolated from local chassis	IRD-EMC-R01



Requirement ID	Description	Value	Source
		ground due to its Kevlar suspension. So that it can be grounded, the 300-mK metalwork shall be wired to the 1.7K connector PCB through the 300-mK to 1.7 K harness. Here it shall be possible to connect it to Bias Ground and/or local chassis	
IRD-DETP-R11	Sensitivity to ionising radiation	The design of the detectors and associated electronics shall be such as to minimise the effects of hits by ionising radiation	Created
IRD-DETP-R12	Volume envelope	The detector modules shall fit within a cylinder of diameter 75 mm (goal 60 mm) and length 100 mm.	Created
IRD-DETP-R13	300 mK thermal load	The thermal dissipation and parasitic load at 300 mK shall be within the specification given in RD15	<a href="#">IRD-COOL-R08</a>
IRD-DETP-R14	Mechanical interface	The detector modules shall mechanically interface to the photometer detector box	Created
IRD-DETP-R15	Eigenfrequency of the detector array structure	The first natural frequency of the detector array structure shall be > 200 Hz (TBC), with a goal of > 250 Hz.	Created

System requirements on the photometer detectors.

### 3.5.6.2 Spectrometer Detectors

#### Performance Requirements

These requirements are set to allow the top level performance requirements of the spectrometer to be achieved

Requirement ID	Description	Value	Source
IRD-DETS-R01	Detective Quantum Efficiency at 20 Hz at nominal incident power levels	SW 200-300 $\mu\text{m}$ > 0.6	<a href="#">IRD-SPEC-R06</a>
		LW 300-400 $\mu\text{m}$ > 0.6	<a href="#">IRD-SPEC-R07</a>
		LW >400 $\mu\text{m}$ as large as possible	
IRD-DETS-R02	Time constant	8 milliseconds (Equivalent to 20 Hz)	<a href="#">IRD-SPEC-R06</a> <a href="#">IRD-SPEC-R07</a> <a href="#">IRD-SPEC-R17</a>
IRD-DETS-R03	Uniformity	NEP spec. shall be met over the whole array Responsivity variations shall be less than 10% across the array and calibrated to an accuracy of <1%	Created
IRD-DETS-R04	Yield (good pixels)	$\geq 90\%$ for each array	<a href="#">IRD-SPEC-R06</a> <a href="#">IRD-SPEC-R07</a>
IRD-DETS-R05	Electrical crosstalk for near neighbour pixels.	Requirement is less than 1% at the output of the cold JFET amplifiers. Goal of less than the optical cross talk	Created
IRD-DETS-R06	Electrical crosstalk	Requirement is less than 0.1% at the output	Created



**INSTRUMENT REQUIREMENTS  
DOCUMENT**

Requirement ID	Description	Value	Source
	any pair of pixels	of the cold JFET preamplifiers. Goal is to be less than the optical cross talk.	
IRD-DETS-R07	Detector angular response	SW array: single mode $2F\lambda$ horns LW array : $2F\lambda$ aperture size at $350\ \mu\text{m}$ with oversized wave guide to allow use up to $670\ \mu\text{m}$ . Over-moding is permitted at $350\ \mu\text{m}$ : single mode at $670\ \mu\text{m}$ with $1F\lambda$ aperture.	IRD-SPEC-R05
IRD-DETS-R08	Spectral response	SW 200-300 $\mu\text{m} \geq 90\%$ LW 300-400 $\mu\text{m} \geq 90\%$ LW > 400 $\mu\text{m}$ as large as possible.	Created
IRD-DETS-R09	Sampling frequency	The spectrometer bolometer pixels shall be capable of being readout at the rate required by the FTS mechanism and position control system – nominally 80 Hz	IRD-SPEC-R17

**Table 3.5-13: Spectrometer detectors performance requirements**

**System Requirements**

Requirement ID	Description	Value	Source
IRD-DETS-R10	Microphonic susceptibility	The design of the detector structural support and the detector harnessing shall be such as to minimise the impact of any microvibration induced in the instrument by internal or external sources	IRD-SPEC-R17
IRD-DETS-R11	EMI susceptibility	The design of any harnesses associated with the detectors that form part of the instrument RF shield shall be such as to minimise the influence of any potential EMI. All metalwork surrounding the detectors at 300 mK is electrically isolated from local chassis ground due to its Kevlar suspension. So that it can be grounded, the 300-mK metalwork shall be wired to the 1.7K connector PCB through the 300-mK to 1.7 K harness. Here it shall be possible to connect it to Bias Ground and/or local chassis	IRD-EMC-R01
IRD-DETS-R12	Sensitivity to ionising radiation	The design of the detectors and associated electronics shall be such as to minimise the effects of hits by ionising radiation	Created
IRD-DETS-R13	Volume envelope	The detector modules shall fit within a cylinder of diameter 75 mm (goal 60 mm) and length 100 mm.	Created
IRD-DETS-R14	300 mK thermal load	The thermal dissipation and parasitic load at 300 mK shall be within the specification given	IRD-COOL-R08



**INSTRUMENT REQUIREMENTS  
DOCUMENT**

---

---

in RD15			
IRD-DETS-R15	Mechanical interface	The detector modules shall mechanically interface to the spectrometer detector box.	Created
IRD-DETP-R16	Eigenfrequency of the detector array structure	The first natural frequency of the detector array structure shall be > 200 Hz (TBC), with a goal of > 250 Hz.	Created

---

**Table 3.5-14: Spectrometer detectors system requirements**



### 3.5.7 Beam Steering Mechanism

#### Performance Requirements

Requirement ID	Description	Value	Source
IRD-BSMP-R01	Maximum throw in chop axis	The BSM shall move the imaged field of view of the detectors by a maximum of $\pm 130$ arcsec on the sky in the $\pm Y$ axis of the satellite	<a href="#">IRD-PHOT-R17</a> <a href="#">IRD-OPS-R06</a> <a href="#">IRD-OPS-R07</a> <a href="#">IRD-OPS-R08</a>
IRD-BSMP-R02	Maximum throw in jiggle axis	The BSM shall move the imaged field of view of the detectors by a maximum of $\pm 30$ arcsec (TBC) in the $\pm Z$ axis of the satellite	<a href="#">IRD-OPS-R06</a> <a href="#">IRD-OPS-R07</a> <a href="#">IRD-OPS-R08</a>
IRD-BSMP-R03	Minimum step in both axis	The minimum step size in either chop or jiggle axes shall be 2 arcsec	<a href="#">IRD-PHOT-R17</a>
IRD-BSMP-R04	Frequency of chop	The chop frequency in either axis shall be continuously variable or selectable in 16 steps from 0 to 2 Hz for nominal operation and power dissipation. The chop frequency should be capable of reaching 5 Hz with increased power dissipation and settling time.	Created
IRD-BSMP-R05	Holding Position	The BSM shall be capable of moving to and holding indefinitely at any commanded position within its range of movement	Created
IRD-BSMP-R06	Stability	The angle on the sky must not vary by more than 0.1 arcsec over 60 sec at the commanded mirror position. The mirror position shall also have a stability equivalent to 0.2 arcsec rms in the 0.03 to 25 Hz frequency band	<a href="#">IRD-SPEC-R17</a>
IRD-BSMP-R07	Position Measurement	The knowledge of the mirror position shall be equivalent to a stability of 0.2 arcsec rms in the 0.03 to 25 Hz frequency band The absolute knowledge of the mirror position shall be equivalent to less than 0.01 arcsec.	<a href="#">IRD-SPEC-R17</a>
IRD-BSMP-R08	Duty Cycle	The mirror shall settle to within 1 arcsec of its commanded position in less than 20 milliseconds.	Created

**Table 3.5-15: Performance requirements on the beam steering mirror.**

#### System Requirements

Requirement ID	Description	Value	Source
IRD-BSMP-R09	Volume envelope	The BSM shall fit within a volume of 130x130x30 mm not including its bracket.	Created
IRD-BSMP-R10	Operating temperature	Nominal operating $< 6$ K. The mechanism shall be capable of operating in a temperature range	Created



Requirement ID	Description	Value	Source
		of 4-300 K	
IRD-BSMP-R11	Thermal isolation	The beam steering mirror structure or mirror temperature shall rise by no more than 1 K from the nominal temperature of the surrounding structure after one hour operation in any mode.	<a href="#">IRD-OPTP-R08</a> <a href="#">IRD-OPTS-R09</a>
IRD-BSMP-R12	Cold power dissipation	The power dissipation into level 1 shall be within the specification in RD15	<a href="#">IID-B-sect-5.9.1</a>
IRD-BSMP-R13	Warm power dissipation	<i>Removed issue 1.0 – see warm electronics requirements.</i>	

**Table 3.5-16: System requirements on the beam steering mirror.**



### 3.5.8 Spectrometer Mirror Mechanism and Position Measurement System

#### Performance Requirements

These requirements are set to allow the top level performance requirements of the spectrometer to be achieved

Requirement ID	Description	Value	Source
<a href="#">IRD-SMEC-R01</a>	Linear Travel	<i>Assumed folding factor of 4 for baseline design and single sided interferograms with short travel beyond zero path difference for phase correction.</i> Total OPD required 14 cm. Maximum mirror travel required for goal resolution (wrt ZPD position): - 0.32 to +3.2 cm	<a href="#">IRD-SPEC-R02</a>
<a href="#">IRD-SMEC-R02</a>	Minimum movement sampling interval	Short wavelength band minimum measurement interval of 5 $\mu\text{m}$ is required (equivalent to 20 $\mu\text{m}$ OPD) For long wavelength band the requirement is 7.5 $\mu\text{m}$ (equivalent to 30 $\mu\text{m}$ OPD)	Created
<a href="#">IRD-SMEC-R03</a>	Sampling step control	The measurement interval must be variable between 5 and 25 $\mu\text{m}$ .	Created
<a href="#">IRD-SMEC-R04</a>	Scan length	The system shall be capable of starting and stopping a scan from either side of the zero path difference position.	Created
<a href="#">IRD-SMEC-R05</a>	Dead-time	A goal is to have a dead-time of no more than 10% per scan when taking data at resolution of 0.4 $\text{cm}^{-1}$	<a href="#">IRD-SPEC-R17</a>
<a href="#">IRD-SMEC-R06</a>	Mirror velocity	For assumed detector response of 20 Hz the maximum required rate of change of the OPD is 0.4 $\text{cm s}^{-1}$ . Required max. mirror velocity 0.1 $\text{cm s}^{-1}$ . A capability to have mirror velocity of 0.2 $\text{cm s}^{-1}$ is desirable and is set as a goal.	Created
<a href="#">IRD-SMEC-R07</a>	Velocity control	The mirror velocity should be selectable from 0 to 0.1 $\text{cm s}^{-1}$ – or 0.2 $\text{cm s}^{-1}$ if the goal performance is achieved.	Created
<a href="#">IRD-SMEC-R08</a>	Velocity stability	The mirror velocity shall be within 10 $\mu\text{m/s}$ r.m.s. within a band width of 0.03 to 25 Hz over the full range of movement of the mechanism	<a href="#">IRD-SPEC-R17</a>

The velocity from scan to scan shall not vary by more than 1% over a period of 24 hours under nominal operating conditions.



**INSTRUMENT REQUIREMENTS  
DOCUMENT**

Requirement ID	Description	Value	Source
IRD-SMEC-R09	Position measurement	Required OPD position accuracy is 1/50 of the smallest step size. Simulation confirms that this adds minimal system noise to the resultant interferogram. Required mirror position measurement accuracy 0.1 $\mu\text{m}$ over $\pm$ 0.32 scan range and 0.3 $\mu\text{m}$ thereafter.	IRD-SPEC-R17
IRD-SMEC-R10	Sampling frequency	The position is sampled at the frequency required for the short wavelength array – i.e.(mirror velocity)/(measurement step size for short wavelength array)	Created

**Table 3.5-17: Performance requirements on the FTS mirror mechanism.  
System Level Requirements**

Requirement ID	Description	Value	Source
IRD-SMEC-R11	Maximum thermal load onto level 1 during cold operation – mechanism and cold position measurement system.	Dissipation shall be within the specification given in RD15	IID-B-sect5.9.1
IRD-SMEC-R12	Maximum envelope	The envelope of the mechanism shall be compatible with avoidance of the optical beams defined by the FTS optics and accommodation on the spectrometer side of the SPIRE optical bench	Created
IRD-SMEC-R13	Thermometers	The SMEC shall provide thermometers as detailed in section 3.5.12	Created
IRD-SMEC-R14	Ground Operation	The mechanism and position measurement system must be capable of full operation on the ground when the instrument is in its normal orientation in the test facility cryostat.	Created

**Table 3.5-18: System requirements on the FTS mirror mechanism**



### 3.5.9 Calibration Sources

#### 3.5.9.1 Photometer Calibration Source

##### Performance Requirements

These requirements are set to allow the top level performance requirements of the photometer to be achieved

Requirement ID	Description	Value	Source
IRD-CALP-R01	Nominal operating output	The area:surface brightness product of the calibrator aperture shall be $\geq 1\%$ of the area:surface brightness product of the telescope image at the position of M4 (with an assumed telescope temperature of 80 K and emissivity of 4%) for $200 < \lambda < 700 \mu\text{m}$ .	Created
IRD-CALP-R02	Operating range	Commandable in 256 steps with at least 124 steps covering the range from zero output to 2% of the power from the telescope.	Created
IRD-CALP-R03	Equivalent obscuration of aperture through BSM mirror	The outside envelope of the calibrator housing shall not foul on any part of the BSM for any operational angular position of the BSM	Created
IRD-CALP-R04	Speed of response	In response to a step change in applied electrical power, the 90% settling time of the radiant power output shall be less than 350 ms (requirement); 70 ms (goal).	Created
IRD-CALP-R05	Repeatability	RMS of output signal better than 1% over 20 cycles on to off during a calibration operation of less than 2 minutes Drift less than 10% over lifetime of the mission. Repeatability of signal 1% for 12 calibration operations equi-spaced over a period of 12 hours, with uniform base temperature and drive current	Created
IRD-CALP-R06	Operation	Nominally once per hour for no more than 10 seconds	Created
IRD-CALP-R07	Frequency	Continuously or pseudo continuously variable between 0 and 2 Hz.	Created

**Table 3.5-19: Performance requirements for photometer calibration source**

##### System Requirements

Requirement ID	Description	Value	Source
IRD-CALP-R08	Interface	The calibrator will be integrated into the beam	Created



**INSTRUMENT REQUIREMENTS  
DOCUMENT**

Requirement ID	Description	Value	Source
		steering mechanism.	
IRD-CALP-R09	Volume envelope	This shall be compatible with the space available within the BSM enclosure as described in the BSM specification document (RD).	Created
IRD-CALP-R10	Thermal isolation	The thermal conductance between the calibrator body and the SPIRE optical bench shall be > 2 mW/K	Created
IRD-CALP-R11	Operating temperature	<6 K	Created
IRD-CALP-R12	Cold power dissipation	Shall be within the specification given in RD15	<a href="#">IID-B-sect5.9.1</a>
IRD-CALP-R13	Warm power dissipation	<i>Removed issue 1.0 – see warm electronics requirements</i>	
IRD-CALP-R14	Operating voltage	Less than 28 V at input power level of 5 mW	Created
IRD-CALP-R15	Redundancy	Cold redundancy for the thermal source	Created
IRD-CALP-R16	Lifetime	The calibration source shall be capable of up to 250,000 operational cycles at the nominal electrical power.	<a href="#">IRD-SUBS-R02</a>

**Table 3.5-20: System Requirements for the photometer calibration source**

**3.5.9.2 Spectrometer Calibration Source**

**Performance Requirements**

These requirements are set to allow the top level performance requirements of the spectrometer to be achieved

Requirement ID	Description	Value	Source
IRD-CALS-R01	Radiated spectrum:	Null the central maximum to accuracy of 5% (goal 2%)  Replicate the dilute spectrum of the telescope to an accuracy of better than 20% (goal 5%) over 200-400 $\mu\text{m}$ .	<a href="#">IRD-SPEC-R17</a>
	<i>Requirement Deleted</i>		
IRD-CALS-R03	Adjustability:	Zero - maximum in 256 steps	Created
IRD-CALS-R04	Uniformity	The uniformity of the intensity from the calibration source across the field image at the detector shall be better than 5%	Created
IRD-CALS-	Repeatability and drift	The output intensity of the calibration source shall drift by no more than 1% over one hour of	Created



**INSTRUMENT REQUIREMENTS  
DOCUMENT**

Requirement ID	Description	Value	Source
R05		continuous operation. The absolute change in the output intensity of the source shall be no more than 15% over the mission lifetime	
IRD-CALS-R06	Operation	The calibration source shall be capable of continuous operation for periods of up to 2 hours with no loss of operational performance.	Created
IRD-CALS-R07	Number of operations	The calibration source shall be capable of up to 12000 operational cycles	<a href="#">IRD-SUBS-R02</a>

**Table 3.5-21: Spectrometer calibrator performance requirements**

**System Requirements**

Requirement ID	Description	Value	Source
IRD-CALS-R08	Operating Voltage	No more than 28 V DC	Created
IRD-CALS-R09	Power dissipation in the focal plane	shall be within the specification given in RD15	<a href="#">IID-B-sect5.9.1</a>
IRD-CALS-R11	Envelope	Cylinder of 70 mm diameter and 100 mm length	Created
IRD-CALS-R12	Thermal Isolation	The SCAL enclosure shall include an attachment point for a thermal strap in case this is necessary to prevent the SCAL thermal load from warming up its environment. A corresponding attachment point for the other end of the strap shall be provided at a suitable place on the structure.	Created
IRD-CALS-R13	Operating Temperature	<6 K	Created
IRD-CALS-R14	Redundancy	Fully redundant systems shall be provided for the active elements.	Created
IRD-CALS-R15	Thermometry	Thermometers shall be provided on the spectrometer calibrator as specified in section 3.5.12	Created
IRD-CALS-R16	Time response	Warm-up time: Stable nominal operating temperature to be reached in less than 30 min (req.); 15 min (goal)  Cool-down time from nominal operating temperature to < 10 K: 3 hrs (requirement); 30 min (goal)	Created

**Table 3.5-22: Spectrometer calibrator systems requirements**



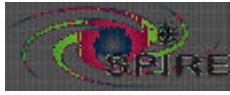

### 3.5.10 JFET Boxes

#### Performance Requirements

Requirement ID	Description	Value	Source
IRD-FTB-R01	Amplifier noise	Requirement better than 10 nV Hz <sup>-1/2</sup> over a bandwidth of 100 to 1400 Hz Goal 7 nV Hz <sup>-1/2</sup>	<a href="#">IRD-PHOT-R04</a> <a href="#">IRD-PHOT-R05</a> <a href="#">IRD-SPEC-R06</a> <a href="#">IRD-SPEC-R07</a>
IRD-FTB-R02	RF rejection	The RF filters, as fitted in the box and with the correct harness, connectors and backshells; shall reject all frequencies from 500 MHz to 10 GHz at -60 dB.	<a href="#">IRD-EMC-R01</a>

**Table 3.5-23: JFET box performance requirements**

#### System Requirements

Requirement ID	Description	Value	Source
IRD-FTB-R04	Envelope	Each JFET/Filter box shall be no more then 300x100x100 mm (TBD)	Created
IRD-FTB-R05	Dissipation	The dissipation of JFET amplifiers shall be heat sunk to the L3 cryostat stage. The dissipation shall be within the specification given in RD15	<a href="#">IID-B-sect-5.9.1</a>
IRD-FTB-R06	Operating temperature range	The JFET amplifiers and RF filters shall be capable of operating in with the temperature of the mounting point of the box in the range 4 to 300-K	Created
IRD-FTB-R07	Mechanical Interface	The JFET boxes shall mount directly to the Herschel optical bench and meet the interface requirements in AD1	<a href="#">IID-A-sect5.6.1.2</a>
IRD-FTB-R08	Nominal operating temperature	The JFET amplifier and RF filter performance requirements shall be maintained with the temperature of the mounting point of the box within the range 4 to 20 K.	Created
IRD-FTB-R09	First natural frequency	The first eigenfrequency of the JFET boxes on their mounts shall be greater than 100 Hz (TBC) with a goal of > 150 Hz	<a href="#">IID-A-sect9.4.1.2.5</a>
IRD-FTB-R10	Thermometers	Thermometers shall be provided on the JFET boxes as specified in section 3.5.12	Created
IRD-FTB-R11	JFET Thermal isolation	The JFET structure shall be thermally isolated from the Herschel optical bench with specification given in RD15	<a href="#">IID-B-sect5.9.1</a>
IRD-FTB-R12	L3 Thermal strap	The JFET structure shall be thermally connected to L3 via a strap with interface specification given in RD15	<a href="#">IID-B-sect5.9.1</a>



Project Document

**INSTRUMENT REQUIREMENTS  
DOCUMENT**

**Ref:** SPIRE-RAL-PRJ-000034

**Issue:** 1.3

**Date:** 14 July 2005

**Page:** Page 62 of 78

**Table 3.5-24: JFET box system requirements**

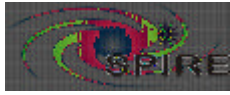

### 3.5.11 FPU RF Filter Modules

#### Performance Requirements

Requirement ID	Description	Value	Source
IRD-RFM-R01	RF rejection	The FPU RF filters, as fitted in the box and with the correct harness, connectors and back-shells; shall reject all frequencies from 500 MHz to 10 GHz at -60 dB.	IRD-EMC-R01

Table 3.5-25: RF Module performance requirements

#### System Requirements

Requirement ID	Description	Value	Source
IRD-RFM-R02	Envelope	The FPU RF filters shall be housed in a single unit of no more than 30x90x230 mm	Created
IRD-RFM-R03	Dissipation	The RF filters will be passive components with no dissipation.	Created
IRD-RFM-R04	Operating temperature range	The RF filters shall be capable of operating in with the temperature of the mounting point of the box in the range 4 to 300-K	Created
IRD-RFM-R05	Nominal operating temperature	<6 K	Created
IRD-RFM-R06	Mechanical interface	The RF modules shall be mounted from the FPU common structure.	Created
IRD-RFM-R07	First natural frequency	The first eigenfrequency of the filter modules shall be greater than 200 Hz (TBC) with a goal of > 300 Hz	Created
IRD-RFM-R08	Capacitance	The capacitance to chassis of the FPU RF filters shall be 2200 pF $\pm$ 20%	Created

Table 3.5-26: RF Module system requirements

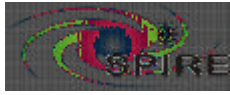

**INSTRUMENT REQUIREMENTS  
DOCUMENT**

**3.5.12 Instrument thermometry**

Table 3.5-29 details the number and locations for the thermometers for the SPIRE cold units. Prime and redundant refers to which of the cold redundant electronics systems will be used to power and read-out the thermistors.

Unit	Location	Acronym	Sensor Type	Nominal Temp. Range	Required Resolution /Accuracy over Range	Prime /Rednt
HSFPU	SOB	T_SOB_1	CX-1030	3 K>100 K	25/50 mK	P
HSFPU	SOB	T_SOB_1	CX-1030	3 K>100 K	25/50 mK	R
HSFPU	SPEC Level 0 box	T_SL0_1	CX-1030	1 K>10 K	2/2 mK	P
HSFPU	SPEC Level 0 box	T_SL0_1	CX-1030	1 K>10 K	2/2 mK	R
HSFPU	PHOT Level 0 box	T_PL0_1	CX-1030	1 K>10 K	2/2 mK	P
HSFPU	PHOT Level 0 box	T_PL0_1	CX-1030	1 K>10 K	2/2 mK	R
HSFPU	Optics sub-bench	T_SUB_1	CX-1030	3 K>100 K	25/50 mK	P
HSFPU	Optics sub-bench	T_SUB_2	CX-1030	3 K>100 K	25/50 mK	R
HSFPU	Input Baffle	T_BAF_1	CX-1030	3 K>100 K	10/10 mK	P
HSFPU	Input Baffle	T_BAF_2	CX-1030	3 K>100 K	10/10 mK	R
HSFPU	FPU SOB/BSM I/F	T_SOB_1	CX-1030	3 K>100 K	10/10 mK	P
HSFPU	FPU SOB/BSM I/F	T_SOB_2	CX-1030	3 K>100 K	10/10 mK	R
HSFPU	SPEC Calibrator Structure	T_SCST_1	CX-1030	10 K>100 K	10/10 mK	P
HSFPU	SPEC Calibrator Structure	T_SCST_2	CX-1030	10 K>100 K	10/10 mK	R
HSFPU	Cooler Pump	T_CPMP_1	CX-1030	3 K>100 K	25/25 mK	P
HSFPU	Cooler Pump	T_CPMP_2	CX-1030	3 K>100 K	25/25 mK	R
HSFPU	Cooler Evaporator	T_CEV_1	CX-1030	0.2 K>5 K	1/1 mK	P
HSFPU	Cooler	T_CEV_1	CX-1030	0.2 K>5 K	1/1 mK	R

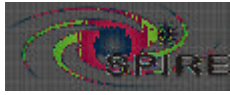

**INSTRUMENT REQUIREMENTS  
DOCUMENT**

Unit	Location	Acronym	Sensor Type	Nominal Temp. Range	Required Resolution /Accuracy over Range	Prime /Rednt
	Evaporator					
HSFPU	Cooler Pump heat switch	T_CPHS_1	CX-1030	1 K>50 K	5/5 mK	P
HSFPU	Cooler Pump heat switch	T_CPHS_2	CX-1030	1 K>50 K	5/5 mK	R
HSFPU	Cooler Evap. Heat switch	T_CEHS_1	CX-1030	1 K>50 K	5/5 mK	P
HSFPU	Cooler Evap. Heat switch	T_CEHS_2	CX-1030	1 K>50 K	5/5 mK	R
HSFPU	Cooler Shunt	T_CSHT_1	CX-1030	0.2 K>5 K	1/1 mK	P
HSFPU	Cooler Shunt	T_CSHT_2	CX-1030	0.2 K>5 K	1/1 mK	R
HSFPU	SPEC Calibrator 4%	T_SCL4_1	CX-1030	10 K>80 K	5/5 mK	P
HSFPU	SPEC Calibrator 4%	T_SCL4_2	CX-1030	10 K>80 K	5/5 mK	R
HSFPU	SPEC Calibrator 2%	T_SCL2_1	CX-1030	10 K>80 K	5/5 mK	P
HSFPU	SPEC Calibrator 2%	T_SCL2_2	CX-1030	10 K>80 K	5/5 mK	R
HSFPU	BSM Mechanism	T_BSM_1	CX-1030	3 K>20 K	10/10 mK	P
HSFPU	BSM Mechanism	T_BSM_2	CX-1030	3 K>20 K	10/10 mK	R
HSFPU	SMEC Mechanism	T_FTS_1	CX-1030	3 K>20 K	10/10 mK	P
HSFPU	SMEC Mechanism	T_FTS_2	CX-1030	3 K>20 K	10/10 mK	R
HSFPU	SMEC/SOB Interface	T_FTS_3	CX-1030	3 K>100 K	25/50 mK	P
HSFPU	SMEC/SOB Interface	T_FTS_4	CX-1030	3 K>100 K	25/50 mK	R

**Table 3.5-27: Required thermometers for the SPIRE cold units.**

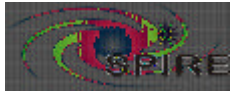

### 3.6 Warm Electronics

#### 3.6.1 Functional Requirements

##### 3.6.1.1 External Functional Requirements

These requirements describe the functionality of the warm electronics as seen by external (satellite) systems.

Requirement ID	Description	Value	Source
IRD-WE-R01	Packet Services	The Warm Electronics shall provide all the mandatory Packet Services. These services are described in the Packet Utilisation Standard (ESA-PSS-07-101)	OIRD
IRD-WE-R02	Telecommands	The Warm electronics shall receive and execute instrument commands as set out in section 2.3.3 <i>These commands are transferred to the instrument as telecommand source packets</i>	Created
IRD-WE-R03	Telemetry	The Warm Electronics shall generate telemetry data as set out in section 2.3.4 <i>These data are transferred from the instrument as telemetry source packets</i>	Created
IRD-WE-R04	Housekeeping	The Warm Electronics shall generate housekeeping data <i>These data are transferred from the instrument as telemetry source packets</i>	IRD-TLM-R05 IRD-TLM-R06
IRD-WE-R05	Operating Modes	The Warm Electronics shall be able to execute all the instrument operating modes These modes are described in RD14	IRD-MODE-R01
IRD-WE-R06	Command Services	The Warm Electronics shall provide the following command types: Atomic Commands - <i>setting of individual parameters of a subsystem</i> Function Commands - <i>execution of a predefined sequence of control actions determined by parameters</i> Command Sequences (TBC) - <i>execution of a sequence of atomic or function commands</i>	Created
IRD-WE-R07	Data Handling	The Warm Electronics shall manage the data handling requirements of the instrument as set out in sections 2.3.4 and 2.3.5 <i>This will include data buffering and manipulation necessary to meet the instrument data requirements</i>	Created

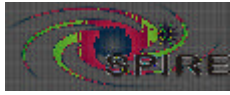

### 3.6.1.2 Internal Functional Requirements

These requirements describe the functionality of the warm electronics as required for operation and control of other SPIRE subsystems

Requirement ID	Description	Value	Source
<a href="#">IRD-WE-R08</a>	Photometer detector readout	The Warm Electronics shall be able to read the data from the photometer detector arrays with the required time accuracy and synchronisation, and within the required accuracy and error <i>This includes data from the detector subsystem (e.g. bias values and temperatures) necessary to the processing of the detector data</i>	Created
<a href="#">IRD-WE-R09</a>	Spectrometer detector readout	The Warm Electronics shall be able to read the data from the spectrometer detector arrays with the required time accuracy and synchronisation, and within the required accuracy and error <i>This includes data from the detector subsystem (e.g. bias values and temperatures) necessary to the processing of the detector data</i>	<a href="#">IRD-DETS-R09</a>
<a href="#">IRD-WE-R10</a>	Spectrometer Position Readout	The Warm Electronics shall be able to read the data from the spectrometer control circuitry with the required time accuracy and synchronisation, and within the required accuracy and error to allow the science data to be processed	<a href="#">IRD-SMEC-R08</a> <a href="#">IRD-SMEC-R09</a> <a href="#">IRD-SMEC-R10</a>
<a href="#">IRD-WE-R11</a>	FTS Control	The Warm Electronics shall be able to control the operations of the FTS subsystem	<a href="#">IRD-SMEC-R01</a> <a href="#">IRD-SMEC-R03</a> <a href="#">IRD-SMEC-R04</a> <a href="#">IRD-SMEC-R07</a> <a href="#">IRD-SMEC-R08</a>
<a href="#">IRD-WE-R12</a>	BSM Control	The Warm Electronics shall be able to control the operations of the BSM subsystem	<a href="#">IRD-BSMP-R03</a> <a href="#">IRD-BSMP-R04</a> <a href="#">IRD-BSMP-R05</a> <a href="#">IRD-BSMP-R06</a> <a href="#">IRD-BSMP-R07</a> <a href="#">IRD-BSMP-R08</a>
<a href="#">IRD-WE-R13</a>	PCAL Control	The Warm Electronics shall be able to control the operations of the Photometer Calibrator subsystem	<a href="#">IRD-CALP-R02</a> <a href="#">IRD-CALP-R07</a> <a href="#">IRD-CALP-R14</a>



Requirement ID	Description	Value	Source
IRD-WE-R14	SCAL Control	The Warm Electronics shall be able to control the operations of the Spectrometer Calibrator subsystem	<a href="#">IRD-CALS-R04</a> <a href="#">IRD-CALS-R05</a> <a href="#">IRD-CALS-R08</a>
IRD-WE-R15	Cooler Control	The Warm Electronics shall be able to control the operations of the Cooler subsystem	<a href="#">IRD-COOL-R04</a> <a href="#">IRD-COOL-R09</a>
IRD-WE-R16		<i>Deleted v1.3</i>	
IRD-WE-R17	Housekeeping	The Warm electronics shall be able to collect housekeeping data from all subsystems at both the nominal and maximum diagnostic rates	<a href="#">IRD-TLM-R06</a>

### 3.6.2 Interface Requirements

Requirement ID	Description	Value	Source
IRD-WE-R18	S/C Interface	The Warm Electronics shall conform to the S/C - instrument interface This is defined in AD1, and the Packet Structure ICD	<a href="#">IID-B-sect5.9.5</a> <a href="#">IID-B-sect5.10</a> <a href="#">IID-Bsect5.11</a> <a href="#">HP-SPIRE-REQ-0020</a> <a href="#">HP-SPIRE-REQ-0030</a> <a href="#">HP-SPIRE-REQ-0090</a> <a href="#">HP-SPIRE-REQ-0100</a>
IRD-WE-R19	Subsystem Interface	The Warm Electronics shall provide interfaces to all the instrument subsystems	Created

### 3.6.3 Performance Requirements

Requirement ID	Description	Value	Source
IRD-WE-R20	Subsystem Control Loops	The Warm Electronics shall conform to the real -time constraints on the subsystem control loops	Create
IRD-WE-R21	Subsystem Data Acquisition	The Warm Electronics shall be able to acquire subsystem data without loss or delay to the instrument operations	Created
IRD-WE-R22	Data Processing	The Warm electronics shall be able to process the instrument data without loss or delay to the instrument operations	Created
IRD-WE-R23	Communication	The Warm Electronics shall be able to meet the S/C communication constraints (telecommand acceptance and telemetry generation) without loss or delay to instrument operations	<a href="#">HP-SPIRE-REQ-0070</a> <a href="#">HP-SPIRE-REQ-0210</a> <a href="#">HP-SPIRE-REQ-0220</a>





### 3.6.4 Autonomy Requirements

Requirement ID	Description	Value	Source
IRD-WE-R24	WE anomalies	The Warm Electronics shall provide functions for determining its own health and safety	IID-A- sect5.13.2.5
IRD-WE-R25	Subsystem anomalies	The Warm Electronics shall handle subsystem anomalies <i>The WE shall be able to recognise anomalies and take a predefined action based on the anomaly</i>	IID-A- sect5.13.2.5
IRD-WE-R26	Anomaly Management	The Warm Electronics shall provide facilities to manage the reporting and response to anomalies. The WE shall prevent multiple reporting of anomalies and provide for disabling of anomaly reporting and execution of response actions.	IID-A- sect5.13.2.5 HP-SPIRE-REQ-0250

### 3.6.5 Reliability Requirements

Requirement ID	Description	Value	Source
IRD-WE-R27	Failure resilience	The Warm Electronics shall minimise through design and hot or cold hardware redundancy the likelihood of failure	Created
IRD-WE-R28	Lifetime	The Warm Electronics shall be designed to operate for 5 years in the space environment	IRD-SUBS-R02
IRD-WE-R29	External Stress	All warm electronics units shall not be damaged or degraded by either a short circuit in any electrical connection to other units or the instantaneous unplugging of a connection to any other unit.	Created

### 3.6.6 Safety Requirements

Requirement ID	Description	Value	Source
IRD-WE-R30	S/C Safety	The Warm Electronics shall prevent failure of any part of the instrument propagating to the S/C.  <i>This may be carried out by monitoring housekeeping data and self-checking</i>	Created

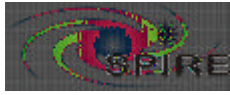

Requirement ID	Description	Value	Source
<a href="#">IRD-WE-R31</a>	Instrument Safety	The Warm Electronics shall prevent harm of the instrument from failure in the S/C. <i>This may be carried out by checking telecommands and monitoring supply levels</i>	Created
<a href="#">IRD-WE-R32</a>	Failure Propagation	The instrument shall be immune to failure propagation <i>Failure of any component shall not have a safety impact on the instrument, another instrument, or on the spacecraft</i>	Created

### 3.6.7 Budgets

Requirement ID	Description	Value	Source
<a href="#">IRD-WE-R33</a>	Mass	The Warm Electronics shall conform to the allocated mass budget in RD8	<a href="#">IID-B-sect5.5</a>
<a href="#">IRD-WE-R34</a>	Volume	The Warm electronics shall conform to the allocated volume envelope in RD8	<a href="#">IID-B-sect5.4</a>
<a href="#">IRD-WE-R35</a>	Power	The Warm Electronics shall conform to the allocated power budget in RD8	<a href="#">IID-B-sect5.9.3</a> <a href="#">HP-SPIRE-REQ-0020</a>

### 3.6.8 Compatibility Requirements

Requirement ID	Description	Value	Source
<a href="#">IRD-WE-R36</a>	EMC	The Warm Electronics shall not provoke any perturbation at spacecraft level or in any other instrument when operating	<a href="#">IID-A-sect5.14</a>

### 3.6.9 Quality Requirements

Requirement ID	Description	Value	Source
<a href="#">IRD-WE-R37</a>	Quality Plan	The Warm Electronics development shall be compliant to the SPIRE Quality Plan	Created

### 3.6.10 Location

Requirement ID	Description	Value	Source
<a href="#">IRD-WE-R38</a>	Mounting Location	The Warm Electronics shall mount to the Herschel SVM panels and meet the interface requirements defined in AD1	<a href="#">IID-A-sect5.6.3</a>

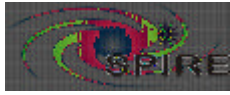

### 3.6.11 Bus Address

Requirement ID	Description	Value	Source
<a href="#">IRD-WE-R39</a>	DPU 1553B Address	The Prime and Redundant sides of the DPU shall have different 1553B bus addresses to allow for inadvertent powering of prime and redundant sides	<a href="#">HP-SPIRE-REQ-0060</a>



### 3.7 Instrument Simulators

#### 3.7.1 FPU Simulator

##### Performance Requirements

Requirement ID	Description	Value	Source
IRD-FSIM-R01	Function	The FPU simulator shall allow the Warm Electronics to be switched on and operated in the absence of the cold FPU unit.	Created
IRD-FSIM-R02	Analogue Outputs	The simulator shall return to the Warm Electronics analogue signals within the range expected for each signal channel to allow the basic function of the analogue Warm Electronics and the instrument commanding to the verified	Created
IRD-FSIM-R03	Control loops	The simulator shall return to the Warm Electronics the appropriate signals to allow the basic function of any control loops to be verified.	Created

Table 3.7-1: FPU simulator performance requirements

##### System Requirements

Requirement ID	Description	Value	Source
IRD-FSIM-R04	Harness	The FPU simulator shall provide a dedicated harness that interfaces directly to the appropriate Warm Electronics unit	Created
IRD-FSIM-R05	Prime and Redundant Interfaces	The FPU simulator shall provide simulation and interfaces to both the prime and redundant channels of the Warm Electronics.	Created

Table 3.7-2: FPU simulator system requirements

#### 3.7.2 DRCU Simulator

##### Performance Requirements

Requirement ID	Description	Value	Source
IRD-DSIM-R01	Function	The DRCU simulator shall allow the DPU to be operated in the absence of the DRCU and cold FPU.	Created
IRD-DSIM-R02	Outputs	The simulator shall return to the DPU the appropriate digital responses to allow the verification of the instrument commanding and all on board software functions including autonomy modes.	Created

Table 3.7-3: DRCU simulator performance requirements

##### System Requirements

Requirement ID	Description	Value	Source
----------------	-------------	-------	--------

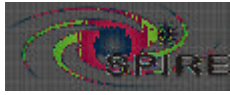

**INSTRUMENT REQUIREMENTS  
DOCUMENT**

IRD-DSIM-R03	Harness	The DRCU simulator shall provide a dedicated harness that interfaces directly to the DPU	Created
IRD-DSIM-R04	Prime and Redundant Interfaces	The DRCU simulator shall provide simulation and interfaces to both the prime and redundant channels of the DPU.	Created

**Table 3.7-4: DRCU simulator system requirements**



Project Document

**INSTRUMENT REQUIREMENTS  
DOCUMENT**

**Ref:** SPIRE-RAL-PRJ-000034

**Issue:** 1.3

**Date:** 14 July 2005

**Page:** Page 74 of 78