

JPL Hardware Requirements Certification Review – SPIRE Element No. D-32428B

Assembly / Subsystem		PEM		Phone	Section		Date
SPIRE		Martin Herman		(818) 354-8541	385		8 August, 2005
Drawing/ Part No.	Dwg. Rev.	Nomenclature		Serial No.	Model	Type	Final IR No.
10209750-1	B	JFET Module		021	FLT-Spare	N/A	926201
Check applicable answer and provide explanation in remarks column		Y E S	N O	N A	Remarks		Data Attachments
1. Are all drawings and specifications complete, approved, released and frozen?		X					14. Latest Top Assembly drawings <input checked="" type="checkbox"/> Attached <input type="checkbox"/> None
2. Do the released drawings and specifications reflect all approved changes?		X					15. List of open ECRs <input type="checkbox"/> Attached <input checked="" type="checkbox"/> None
3. Is hardware identical to other hardware delivered? If no, provide difference list.		X					16. Waivers (RFW request for waiver) <input checked="" type="checkbox"/> Attached <input type="checkbox"/> None
4. Does the hardware meet its functional requirements, specifications, waivers, ICDs?		X			EIDP and RFW are attached		17. Open MRB <input type="checkbox"/> Attached <input checked="" type="checkbox"/> None
5. Are all IR and MRB dispositioned and concurred by QA?		X					18. Open PFR on this H/W <input type="checkbox"/> Attached <input checked="" type="checkbox"/> None
6. Is complete as-built list information included in the build book?		X					19. Open PFR on similar H/W PFR #Z86998 <input checked="" type="checkbox"/> Attached <input type="checkbox"/> None
7. Have all required environmental tests & analyses been completed?		X			ETAS and RFW for Sine Vibration are attached		20. Handling Document → See Item 11 <input checked="" type="checkbox"/> Attached <input type="checkbox"/> None
8. Is all required assembly and/or subsystem level functional testing complete?		X			Performance Test Data Attached		21. Shortage List <input type="checkbox"/> Attached <input checked="" type="checkbox"/> None
9. Have all piece parts, processes and materials been approved by JPL?		X					22. Requirements Verification Matrix <input checked="" type="checkbox"/> Attached (See #4, #7, #8) <input type="checkbox"/> None
10. Does this hardware meet all contamination control requirements?		X			Parts, processes and MIUL met all contamination control and out-gassing requirements		23. Qualification Status <input checked="" type="checkbox"/> Attached <input type="checkbox"/> None
11. Are all shipping containers, shipping and special handling procedures ready?		X			See Attached Document D-26790		24. Mate / Demate Record <input checked="" type="checkbox"/> Attached <input type="checkbox"/> None
12. Is additional work required to bring this hardware to flight (flight-spare) readiness?			X				25. Operating Log <input checked="" type="checkbox"/> Attached (See Item # 24) <input type="checkbox"/> None
13. Is this hardware acceptable for flight?		X					26. MICD <input checked="" type="checkbox"/> Attached <input type="checkbox"/> None
							Signature & Date

S/N 021

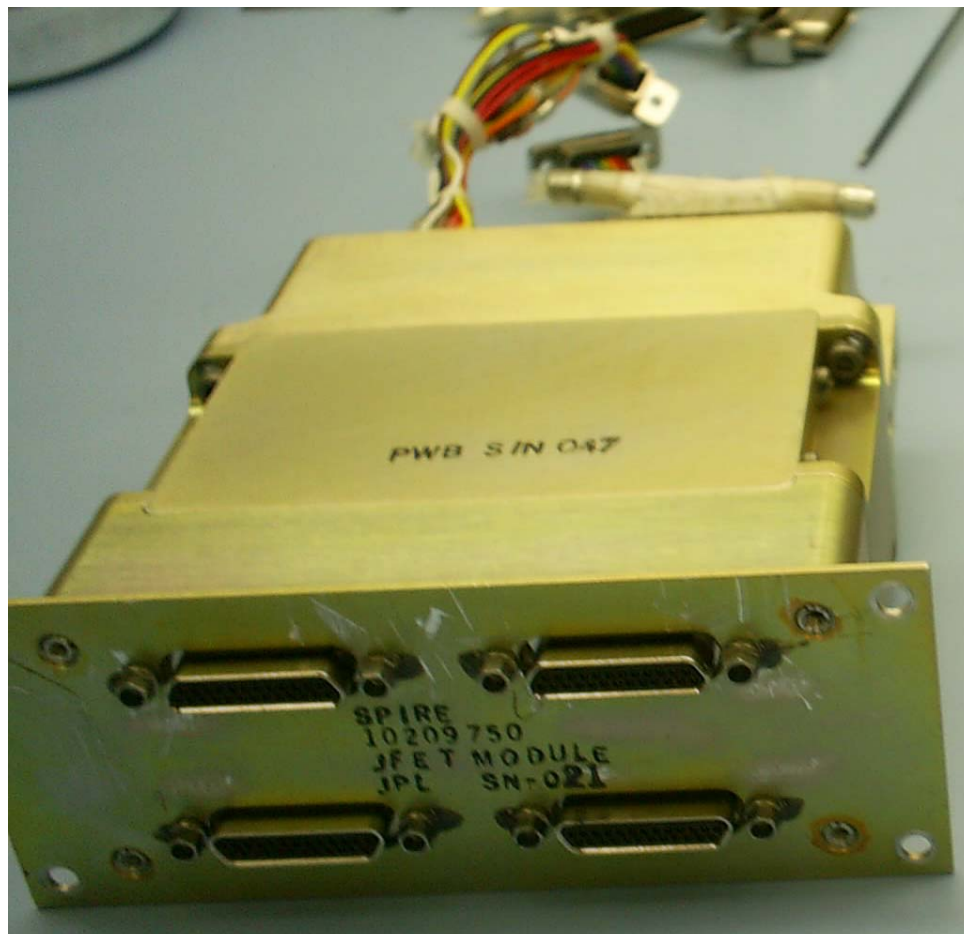

RAL EIDP Table of Contents Versus JPL HRCR Check List Item Numbers

RAL EIDP Section Number	RAL EIDP Title	JPL HRCR Check List Item Number	Notes
1	Shipping Documents		Shipper and Final IR
2	Transportation, Packing, Handling & Integration Procedures	11	Special Handling Document D-26790
3	Certificate of Conformance / Delivery Review Board MOM		HRCR book is the C of C
4	As Built Configuration Status List	1 & 2	Assembly Drawings
5	List of Waivers	4	RFW (request for waiver) Attached
6	Copies of Waivers	4 & 7	RFW (request for waiver) Attached
7	List of Non-Conformance Reports		See RFW in 4 & 7
8	Copies of Non-Conformance Reports		See RFW in 4 & 7
9	Cleanliness Statement		Final IR QA Inspection
10	Operational Manual		NA
11	Top Level Drawings (inc. Family Tree)	14	Top Assembly Drawing
12	Interface Drawings	26	MICD Drawing
13	Functional, Block & Mechanical Drawings		NA
14	Electrical Circuit Drawings		NA
15	Serialized Components List		In build books – not shipped
16	Mass Properties/ Power Budget	HRCR Check List Page 1	Mass listed in HRCR check list
17	Qualification Status List / Test Matrix	23	Qualification Unit Test Matrix
18	Test Reports	4, 7, 8, 23	
19	Open Work / Deferred Work / Open Tests		NA
20	Calibration Data		NA
21	Historical Record	23	Qualification Unit Test Matrix
22	Manufacturing Logbook(s)		In build books – not shipped
23	Operating Time / Cycle Record	25	
24	Connector Mating Record	24	
25	Age Sensitive Items Record		NA
26	Pressure Vessels – History/Test Record		NA
27	Temporary Installation Record		NA
28	Reference List of EIDPs (Lower level)		NA
29	Other Useful Information		NA

JPL Hardware Requirements
Certification Review (HRCR)

Junction Field Effect Transistor (JFET)
Flight-Spare Module

10209750-1 S/N 021

SPIRE Element
Herschel Space Observatory Project

August 8, 2005

Configuration of Module, Boards & Membranes

Module 10209750-1	S/N 21	S/N 21
PWB 10209760-1	S/N 47	S/N 53
Membrane 10209758-1	J6.17.3	J5.4.1

Attachment of HRCR Items #1 Drawing Release Status

ALL ASSEMBLY & PARTS DRAWINGS ARE RELEASED IN PDMS

Released Drawings:

- 10209719-1 assembly built per released Rev. A drawing (studlock)**
- 10209722-1 assembly built per released Rev. B drawing (interface drawing)**
- 10209750-1 assembly built per released Rev. B drawing (module assy)**
- 10209751-1 assembly built per released Rev. B drawing (chassis 1)**
- 10209752-1 assembly built per released Rev. A drawing (chassis 2)**
- 10209753-1 assembly built per released Rev. A drawing (chassis 3)**
- 10209754-1 assembly built per released Rev. C drawing (mount)**
- 10209756-1 assembly built per released Rev. B drawing (chassis lid)**
- 10209757-1 assembly built per released Rev. A drawing (membrane)**
- 10209758-1 assembly built per released Rev. A drawing (membrane assy)**
- 10209759-1,-2,-4 redlined Rev. B drawing (gasket)**
- 10209760-1 assembly built per released Rev. C drawing (board assembly)**
- 10209761-1 assembly built per released Rev. C drawing (solder connector)**
- 10209769-1 assembly built per released Rev. A drawing (stiffener)**
- 10209777-1 assembly built per released Rev. B drawing (board)**
- 10209858-2 assembly built per released Rev. A drawing (special fastener)**
- 10217636-1 assembly built per released Rev. A drawing (clip)**

Attachment of HRCR Item #4: EIDP (End Item Data Package)

EIDP Coveragepage For JFET Testing						
Unit Identification						
Name	:	JFET PFM Module				
Part #	:	10209750-1				
S/N	:	#021				
Environmental Testing						
		Axes Tested	Temp	Duration/ # of Cycle	Requirement	Source
Random Vibration Test		X, Y, Z	Rm T	1 min/axis	X, Y, Z	SSSD, JFET-DES-07
High Level Sine Wibe Test		None	NA	NA	X, Y, Z	SSSD, JFET-DES-07
Bakeout		NA	80 C	24 hrs	> 24 HRS	
Thermal Cycles		NA	RmT to 80 K	2	Minimum 1	D-20549
Performance Characteristics						
			Specification		Source	Waiver
Power needed for < 11 bad channels (Min Perf.)	7.70 mW		11 mW for CQM, 7 mW for PFM/FS		SSSD, JFET-TEC-05, JFET-PER-02	HR-SP-JPL-RFW-004
Power needed for < 4 bad channels (Design Value)	9.35 mW		11 mW for CQM, 7 mW for PFM/FS		SSSD, JFET-TEC-05, JFET-PER-02	HR-SP-JPL-RFW-004
Power needed for 100 % Yield per unit*	9.93 mW		NA		NA	*noise yield only
Median Noise at < 11 bad chs.	8.78 nV/rtHz	< 15 nV/rtHz			SSSD, JFET-PER-01	
Median Noise at < 4 bad chs.	7.06 nV/rtHz	Min	< 7 nV/rtHz		SSSD, JFET-PER-01	
Median Noise at 100 % Yield*	7.16 nV/rtHz	Performance	Design Value		SSSD, JFET-PER-01	
# of Channels over the max. offset voltage	3	< 15 mV			SSSD, BDA-DRCU-27	
Common Mode Rejection Ratio	< -60 dB by design, as measured in EM4 unit				SSSD, BDA-DRCU-11	
Board Level Details						
		Board SN 047 (JAA-JDD)		Board SN 053 (JAA'-JDD')		Source
# Channels Tested	:	24		24		
Median Noise at 3.5 mW	:	8.03 nV/rtHz		13.98 nV/rtHz		SSSD, JFET-PER-01
# of good channels at 3.5 mW	:	17	83.3% Yield	13	54.2% Yield	SSSD, JFET-PER-02
Power Needed for 100 % Yield*	:	4.60 mW		5.33 mW		SSSD, JFET-PER-02
Median Noise at High Power (w/ 100 % Yield*)		7.24 nV/rtHz		7.05 nV/rtHz		SSSD, JFET-PER-01
Median Gain at High Power		0.97		0.98		NA
Heater Resistance, 4K Reference value	:	3.63 kΩ		2.77 kΩ		NA
Definitions						
Good Channels	:	Noise less than a min. performance value of 15 nV/rtHz				
Yield	:	# of Good Channels / 24				
Filenames						
Noise Measurements	:	JFET_Mod21_brd47_Noise_perEIDP.xls		JFET_Mod21_brd53_Noise_perEIDP.xls		
Source Voltages (RmT, 4K)	:	JFET Module 20,21 source voltage data,50,51,47,53 061305.xls				
Notes						
1)	The Base temperature for all performance characterization was 4K					
2)	All Noise Measurements were made with the inputs shorted to ground					
3)	Type of membranes:	SN047: 40% Overetched		SN053: 26% Overetched		

Attachment of HRCR Item # 4: RFW (Request For Waiver)

RFW/RFD Number:	HR-SP-JPL-RFW-017
------------------------	--------------------------

Spacecraft / Project	Herschel	Originator's Name	Steve Tseng
System / Experiment / Model	1.1 SPIRE	Signature / Date	
Sub-System	detectors	Request Type (Highlight applicable request)	Waiver (RFW) Deviation (RFD)
Assembly	JFET modules	1.1.1.1 <u>Organisation</u>	Jet Propulsion Laboratory
Sub-Assembly		Ref. Doc. / Drwg No.	SPIRE-JPL-PRJ-000456
Item		References	
Serial No.			
RFW/RFD Title	JFET Thermal Control (TC) Module 10209750-1 S/N 021		

End Items(s) Affected (Hardware, Software)				
Name	CI-Number		Model(s)	
JFET Module P/N 10209750 S/N 21			PTC	
Requirement / Interface Documents Affected				
Specification/Drawing Title	Number	Issue	Date	App. Paragraph
BDA-SSSD	SPIRE-JPL-PRJ-0004456		May 11th, 2005	
Description of Deviation / Discrepancy / Non-Conformance				
Three channels of high offsets (values 0.016V, 0.021V and 0.023V) are in the final circuitry.				
Other Items or Requirements (Potentially) Affected				
Other than channels having high offset voltages, the board assembly 10209760-1 S/N 047 and this module are in flight and flight-spare configurations.				
Need for RFW/RFD and Rationale for Acceptance				
This module to be used as JFET Thermal Control (TC) Module				

	Approved	Rejected	Name	Date
Engineering:				
Product Assurance:				
CCB-Chairman:				
Principal Investigator				
Product Assurance:				
Co-Investigator				
Prime Contractor				
ESA Project Office				

Attachment of HRCR Item # 4: RFW (Request For Waiver)

		RFW/RFD Number:	HR-SP-JPL-RFW-23	
Spacecraft / Project	Herschel	Originator's Name	Steve Tseng	
System / Experiment / Model	1.2 SPIRE	Signature / Date		
Sub-System	detectors	Request Type (Highlight applicable request)	Waiver (RFW)	Deviation (RFD)
Assembly	JFET modules	1.2.1.1 <u>Organisation</u>	Jet Propulsion Laboratory	
Sub-Assembly		Ref. Doc. / Drwg No.	SPIRE-JPL-PRJ-000456	
Item		References		
Serial No.				
RFW/RFD Title	JFET Power Dissipation S/N 021			

End Items(s) Affected (Hardware, Software)		
Name	CI-Number	Model(s)
JFET Module p/n 10209750 S/N 021		Flight-Spare

Requirement / Interface Documents Affected				
Specification/Drawing Title	Number	Issue	Date	App. Paragraph
BDA-SSSD	SPIRE-JPL-PRJ-0004456	3.2	7/1/03	JFET-PER-01 JFET-PER-02 JFET-TEC-05

Description of Deviation / Discrepancy / Non-Conformance
 Requirement states that dissipation of photometer JFETs is to be less than 7 mW average, while supplying 90% of channels with voltage noise < 15 nV/rHz according to BDA-SSSD JFET-PER-01, JFET-PER-02, JFET-TEC-05. Measured JFET performance of the JFETs indicates that 7.70 mW of power dissipation will be required to meet the specified yield and noise performance specifications.

Other Items or Requirements (Potentially) Affected
 Overall sensitivity of the bolometer sub-system is affected by JFET noise performance. JFET power dissipation impacts the heat sink temperature of the 3He refrigerator and may in turn increase the base detector temperature. Dissipation of JFETs affects power dissipation on cryostat.

Need for RFW/RFD and Rationale for Acceptance
 Measured JFET performance of JFETs indicates that 7.70 mW of power dissipation will be required to meet the specified yield and noise performance specifications. JPL is unable to significantly alter the JFET fabrication process in order to meet the power specification without undue risk to the stated PFM/FS delivery dates. Furthermore, JPL requests a full system optimisation to revisit the noise and power requirements on the JFETs. The JFET modules can meet the noise design value with 100 % yield at 9.93 mW.

	Approved	Rejected	Name	Date
Engineering:				
Product Assurance:				
CCB-Chairman:				
Principal Investigator				
Product Assurance:				
Co-Investigator				
Prime Contractor				
ESA Project Office				

Attachment of HRCR Item #7: RFW (Request For Waiver)

	REQUEST FOR WAIVER / DEVIATION (RFW/RFD)	PRODUCT ASSURANCE Space Science and Technology Department
---	---	--

RFW/RFD Number:	HR-SP-JPL-RFW-005v1
------------------------	----------------------------

Spacecraft / Project	Herschel	Originator's Name	Kalyani Sukhatme
System / Experiment / Model	SPIRE	Signature / Date	
Sub-System	detectors	Request Type (Highlight applicable request)	Waiver (RFW) Deviation (RFD)
Assembly		Organisation	Jet Propulsion Laboratory
Sub-Assembly		Ref. Doc. / Drwg No.	SPIRE-JPL-PRJ-000456
Item		References	
Serial No.			

RFW/RFD Title	BDA and JFET module sine test deletion
----------------------	---

End Items(s) Affected (Hardware, Software)		
Name	CI-Number	Model(s)
Bolometric Detector Assemblies JFET Modules		CQM, PFM, FS CQM, PFM, FS

Requirement / Interface Documents Affected				
Specification/Drawing Title	Number	Issue	Date	App. Paragraph
BDA-SSSD (SPIRE-JPL-PRJ-000456)		3.2	Jan 7, 2003	BDA-DES-10, JFET-DES-07

Description of Deviation / Discrepancy / Non-Conformance

High Level Sine- Vibe Test is not performed on these units

Other Items or Requirements (Potentially) Affected

Need for RFW/RFD and Rationale for Acceptance

The hardware has to be qualified under a cold vibration test and is installed in the cold vibration facility for the purpose of the test. The high level sine vibration test configuration will put the hardware and the personnel at risk since the cold vibration facility is not structurally capable of withstanding the high levels. Obtaining additional resources (cost and schedule) for developing a new set-up is not feasible at this time.

Up issue RFW to 5v1 with this note added

There is no Requirement to do a high level sine test on previously Qualified units, Only Random Acceptance level test are required.

	Approved	Rejected	Name	Date
Engineering:	REF SPIRE – RAL-MOM- 002250		 Digitally signed by Eric Clark Date: 2004.12.22 08:57:49 Z	20 December 04
Product Assurance:				20 December 04
CCB-Chairman:				
Principle Investigator				
Product Assurance:				
Co-Investigator				
Prime Contractor				
ESA Project Office				

Attachment of HRCR Item #7: ETAS (Environmental Test Summary)

ENVIRONMENTAL TEST AUTHORIZATION AND SUMMARY (ETAS)					
AUTHORIZATION SECTION					
PROJECT Herschel			LOG NO. HS043		
SUBSYSTEM/ASSEMBLY TITLE E JFET Modules S/N 20,21				DATE ISSUED 5/9/05	
REFERENCE DESIGNATION NUMBER		PART NO. (IF MULTIPLE, ATTACH LIST) 10209750-1		REV. SERIAL NO. 020,021	
HARDWARE TYPE <input type="checkbox"/> EM QUAL <input checked="" type="checkbox"/> FLIGHT <input type="checkbox"/> FLIGHT SPARE <input type="checkbox"/> OTHER			PRE-ENVIRONMENTAL INSPECTION REPORT NUMBER (ATTACH IR)		
WIRING HARNESS <input type="checkbox"/> EM QUAL <input type="checkbox"/> FLIGHT <input type="checkbox"/> EM <input type="checkbox"/> SE			PART NO.		REV. SERIAL NO.
TEST DESCRIPTION (CHECK ALL APPLICABLE) <input type="checkbox"/> SINE VIBRATION <input type="checkbox"/> PYROSHOCK <input type="checkbox"/> ACOUSTIC <input type="checkbox"/> EMC <input type="checkbox"/> OTHER _____ <input checked="" type="checkbox"/> RANDOM VIBRATION <input checked="" type="checkbox"/> THERMAL VAC. <input type="checkbox"/> THERMAL ATMOSPHERE				TYPE OF TEST <input type="checkbox"/> QUALIFICATION <input type="checkbox"/> FLIGHT ACCEPTANCE <input checked="" type="checkbox"/> PROTO FLIGHT <input type="checkbox"/> RETEST	
WILL ALL TESTS/LEVELS/DURATIONS REQUIRED BY THE PROJECT DOCUMENTS BE PERFORMED ON THIS UNIT? <input checked="" type="checkbox"/> YES <input type="checkbox"/> NO (IF NO, ATTACH EXCEPTIONS LIST) ENTER PROJ. DOC. NO. AND REV. _____					
HAS THE UNIT PASSED ALL PRE-ENVIRONMENTAL FUNCTIONAL TESTS? <input checked="" type="checkbox"/> YES <input type="checkbox"/> NO (IF NO, ATTACH EXCEPTIONS LIST) BRIEF EXPLANATION					
HAVE ALL DESIGN ANALYSES BEEN COMPLETED AND REQUIRED CHANGES BEEN IMPLEMENTED? <input checked="" type="checkbox"/> YES <input type="checkbox"/> NO (IF NO, ATTACH EXCEPTIONS LIST) BRIEF EXPLANATION					
IS THE TEST ARTICLE IDENTICAL TO OTHER FLIGHT UNITS? <input checked="" type="checkbox"/> YES <input type="checkbox"/> NO (IF NO, ATTACH EXCEPTIONS LIST) BRIEF EXPLANATION					
ARE ALL PFRs AGAINST THIS UNIT CLOSED? <input checked="" type="checkbox"/> YES <input type="checkbox"/> NO (IF NO, ATTACH EXCEPTIONS LIST) BRIEF EXPLANATION					
HAVE ALL WAIVERS AND ECRs BEEN APPROVED AND ARE THEY INCORPORATED? <input checked="" type="checkbox"/> YES <input type="checkbox"/> NO (IF NO, ATTACH EXCEPTIONS LIST) BRIEF EXPLANATION					
TEST AUTHORIZED BY					
COGNIZANT ENGINEER <i>[Signature]</i>		DATE		TECHNICAL MGR./INSTR MRG./PI PREP REP <i>[Signature]</i>	
				DATE	
				ENVIRONMENTAL REQUIREMENTS ENG. <i>[Signature]</i>	
				DATE	
SUMMARY SECTION					
TEST AGENCY (IF MULTIPLE, ATTACH SUMMARY AND TEST DATES) JPL Building 144		TEST INITIATION DATE 05/10/05		ACCUMULATED OPERATING HOURS PRIOR TO FIRST ENVIRONMENTAL TEST	
SERIAL NUMBERS ACTUALLY TESTED 020,021		TEST TERMINATION DATE		OPERATING HOURS DURING ENVIRONMENTAL EXPOSURE	
TEST DESCRIPTION					
VIBRATION AXES: X Y Z SINE VIBRATION <input type="checkbox"/> <input type="checkbox"/> <input type="checkbox"/> RANDOM VIBRATION <input checked="" type="checkbox"/> <input checked="" type="checkbox"/> <input checked="" type="checkbox"/>		ACOUSTIC <input type="checkbox"/>		PYROSHOCK SHOCK AXES: X Y Z <input type="checkbox"/> <input type="checkbox"/> <input type="checkbox"/> SHOCKS/AXIS:	
EMC <input type="checkbox"/> ESD		COND. SUSC. <input type="checkbox"/> COND. EMIS. <input type="checkbox"/> RAD. SUSC. <input type="checkbox"/> RAD. EMIS. <input type="checkbox"/>		ISOLATION <input type="checkbox"/> MAGNETICS <input type="checkbox"/>	
THERMAL VACUUM PRESSURE: <10E-5 <77K NO OF CYCLES: 2 = # <= 3		TEMPERATURE ATMOSPHERE NO OF CYCLES:		OTHER	
TEMP. LEVEL (°C) AND ACCUMULATED DURATION (HRS.) HOT: _____°C, _____h COLD: _____°C, _____h HOT: _____°C, _____h COLD: _____°C, _____h					
WERE THERE ANY PFRs GENERATED DURING ENVIRONMENTAL TESTS? <input type="checkbox"/> YES <input checked="" type="checkbox"/> NO (IF NO, ATTACH EXCEPTIONS LIST)			LIST PFR NOS. / BRIEF EXPLANATION		
ARE THE POST ENVIRONMENTAL DAMAGE INSPECTIONS COMPLETE? <input checked="" type="checkbox"/> YES <input type="checkbox"/> NO (IF YES, ATTACH A COPY OF THE INSPECTION REPORTS. IF NO, ATTACH EXPLANATION)			LIST PFR NOS. / BRIEF EXPLANATION		
WERE ALL PLANNED TESTS/LEVELS/DURATIONS ACHIEVED? <input checked="" type="checkbox"/> YES <input type="checkbox"/> NO (IF NO, ATTACH EXCEPTIONS LIST)			LIST PFR NOS. / BRIEF EXPLANATION		
TESTS HAVE NOT BEEN SUCCESSFULLY COMPLETED. SEE THE ATTACHED SUMMARY FOR ACTIONS THAT NEED TO BE TAKEN.					
COGNIZANT ENGINEER <i>[Signature]</i>		DATE		TECHNICAL MGR./INSTR MRG./PI PREP REP <i>[Signature]</i>	
				DATE	
				ENVIRONMENTAL REQUIREMENTS ENG. <i>[Signature]</i>	
				DATE	
HARDWARE HAS SUCCESSFULLY COMPLETED THE ENVIRONMENTAL TESTS LISTED ON THIS FORM OR REMAINING ACTIONS HAVE BEEN TAKEN, INCLUDING RETEST.					
COGNIZANT ENGINEER <i>[Signature]</i>		DATE		TECHNICAL MGR./INSTR MRG./PI PREP REP <i>[Signature]</i>	
				DATE	
				ENVIRONMENTAL REQUIREMENTS ENG. <i>[Signature]</i>	
				DATE	

Vib performed on 05/10/05 # 19105 245460

Attachment of HRCR Item #7: ETAS (Environmental Test Summary)

	ENVIRONMENTAL TEST AUTHORIZATION AND SUMMARY (ETAS)
OTHER AUTHORIZATION PROVISIONS AND EXPLANATIONS	
<p>is a 3-axis warm vibration test (room temp) done on the JFET flight modules SN020 and 021. The test will be done with the JFET unit mounted inside a mock-up JFET rack. The unit will be assessed both before and after the test with visual inspections and electrical checkouts. 3 response accelerometers will be mounted onto the JFET rack in order to give response data.</p> <p>2 to 3 vacuum thermal cycles will also be completed.</p> <p>2 cycles were completed. R/b 7/12/05</p>	
FORM 2 JPL 2683 R 1/98 FF	

Attachment of HRCR Item #7: ETAS (Environmental Test Summary)

ENVIRONMENTAL TEST AUTHORIZATION AND SUMMARY (ETAS)		ENVIRONMENTAL TEST SUMMARY				COMMENTS															
HARDWARE	S/N	ETAS	TEST ENVIRONMENT LEVELS & DURATION	DATE TEST PERFORMED	TEST AGENCY		PASS/ FAIL														
SPIRE JFET (10209750-1)	020,02 1	HSO43	<p>X, Y, and Z 1 minute Random Vibe</p> <table border="1"> <thead> <tr> <th>Frequency [Hz]</th> <th>Spec [g².Hz]</th> </tr> </thead> <tbody> <tr> <td>20</td> <td>0.01</td> </tr> <tr> <td>100</td> <td>0.05</td> </tr> <tr> <td>300</td> <td>0.05</td> </tr> <tr> <td>499</td> <td>0.0214</td> </tr> <tr> <td>500</td> <td>0.0214</td> </tr> <tr> <td>2000</td> <td>0.00214</td> </tr> </tbody> </table> <p>Each axis 1/4 g sine sweep 20-2000 Hz each axis</p> <p>2-3 vacuum thermal cycles. <10E-5 mbar, <70K</p>	Frequency [Hz]	Spec [g ² .Hz]	20	0.01	100	0.05	300	0.05	499	0.0214	500	0.0214	2000	0.00214				
Frequency [Hz]	Spec [g ² .Hz]																				
20	0.01																				
100	0.05																				
300	0.05																				
499	0.0214																				
500	0.0214																				
2000	0.00214																				

Attachment of HRCR Item # 8: Test Data - Source Voltage Data

JFET SOURCE VOLTAGE MEASUREMENT																	
SN20,21 module, re-test in green dewar.																	
power cable		pwr1		pwr2		pwr3		pwr4		pwr1		pwr2		pwr3		pwr4	
Date		6/30/2005		6/30/2005		6/30/2005		6/30/2005		7/5/2005		7/5/2005		7/5/2005		7/5/2005	
T _{plate}		4 K		4 K		4 K		4 K		rmT		rmT		rmT		rmT	
T _{JFET}		4 K		4 K		4 K		4 K		rmT		rmT		rmT		rmT	
V _{dd}		3		3		3		3		3		3		3		3	
V _{ss}		-1.5		1.5		-1.5		-1.5		-1.5		-1.5		-1.5		-1.5	
V _{dd} '		2.741		2.752		2.756		2.713		2.716		2.727		2.73		2.679	
V _{ss} '		-1.239		-1.25		-1.253		-1.211		-1.213		-1.224		-1.227		-1.177	
I _{dd}		0.9897		0.948		0.936		1.0994		1.072		1.0303		1.0203		1.2114	
I _{ss}		0.9886		0.947		0.9346		1.0983		1.0706		1.029		1.019		1.2101	
SN		50		51		47		53		50		51		47		53	
Channel #			DELTA		DELTA		DELTA		DELTA		DELTA		DELTA		DELTA		DELTA
1	a	0.924	0.007	0.684	0.001	1.059	0.007	0.483	0.002	1.183	0.006	0.957	0.001	1.318	0.007	0.772	0.005
	b	0.931		0.685		1.066		0.485		1.189		0.956		1.325		0.777	
2	a	0.861	0.001	0.642	0.003	0.721	0.003	0.580	0.001	1.123	0.001	0.915	0	0.994	0.003	0.865	0.001
	b	0.862		0.645		0.724		0.581		1.124		0.915		0.997		0.866	
3	a	0.755	0.003	0.762	0	0.716	0.001	0.392	0.004	1.019	0.004	1.028	0	0.991	0	0.682	0.006
	b	0.758		0.762		0.717		0.396		1.023		1.028		0.991		0.688	
4	a	0.855	0.002	0.862	0.008	0.956	0.012	0.497	0.002	1.116	0	1.125	0.008	1.220	0.009	0.787	0.001
	b	0.857		0.870		0.944		0.499		1.116		1.133		1.211		0.798	
5	a	0.796	0.002	0.725	0.004	0.584	0.021	0.553	0.004	1.061	0.001	0.993	0.002	0.861	0.022	0.839	0.006
	b	0.798		0.721		0.563		0.557		1.062		0.991		0.839		0.845	
6	a	0.923	0.003	0.764	0.011	0.923	0.005	0.544	0.001	1.182	0.002	1.035	0.009	1.192	0.005	0.833	0
	b	0.926		0.775		0.918		0.543		1.184		1.044		1.187		0.833	
7	a	0.860	0	0.699	0.004	0.614	0.023	0.731	0.001	1.123	0.001	0.971	0.004	0.892	0.024	1.015	0.001
	b	0.860		0.703		0.591		0.732		1.124		0.975		0.868		1.014	
8	a	0.780	0.007	0.686	0	0.684	0	0.471	0.007	1.049	0.004	0.957	0.001	0.967	0	0.765	0.008
	b	0.787		0.686		0.684		0.478		1.053		0.958		0.967		0.773	
9	a	0.787	0.001	1.324	0.013	1.039	0.01	0.464	0.001	1.057	0.001	1.568	0.013	1.311	0.008	0.776	0.001
	b	0.786		1.311		1.049		0.463		1.056		1.555		1.319		0.775	
10	a	0.781	0.005	0.778	0.002	0.685	0.001	0.692	0.005	1.057	0.003	1.047	0	0.970	0.001	0.993	0.003
	b	0.776		0.780		0.686		0.687		1.054		1.047		0.971		0.990	
11	a	0.660	0.01	0.762	0.007	0.751	0.003	0.694	0.002	0.941	0.009	1.028	0.014	1.044	0.003	0.987	0.002
	b	0.670		0.754		0.754		0.696		0.950		1.042		1.047		0.989	
12	a	0.867	0.001	0.697	0.001	0.785	0.004	0.563	0.009	1.135	0.001	0.974	0.001	1.075	0.005	0.863	0.008
	b	0.868		0.696		0.789		0.572		1.134		0.973		1.080		0.871	
13	a	0.824	0.006	0.676	0.001	0.783	0.002	0.482	0.004	1.097	0.004	0.960	0.001	1.064	0.001	0.777	0.006
	b	0.818		0.677		0.785		0.486		1.093		0.961		1.065		0.783	
14	a	0.832	0.001	0.675	0.003	0.780	0.001	0.565	0.005	1.104	0	0.956	0.004	1.062	0.002	0.862	0.004
	b	0.831		0.678		0.779		0.570		1.104		0.960		1.060		0.866	
15	a	0.867	0.009	0.946	0.01	0.927	0.005	0.437	0.001	1.132	0.006	1.213	0.008	1.199	0.003	0.743	0.002
	b	0.858		0.956		0.932		0.436		1.126		1.221		1.202		0.741	
16	a	1.498	0.007	0.679	0.003	0.771	0.001	0.593	0.001	1.737	0.006	0.966	0.002	1.060	0	0.880	0.002
	b	1.505		0.678		0.772		0.592		1.743		0.964		1.060		0.878	
17	a	1.503	0.012	1.057	0.006	0.767	0.002	0.530	0.006	1.741	0.012	1.315	0.006	1.043	0.001	0.820	0.005
	b	1.491		1.063		0.769		0.536		1.729		1.321		1.044		0.825	
18	a	1.383	0.012	0.691	0.001	0.857	0.016	0.458	0.004	1.624	0.01	0.964	0.001	1.129	0.016	0.746	0.004
	b	1.395		0.692		0.841		0.454		1.634		0.965		1.113		0.742	
19	a	0.735	0.003	1.035	0.002	0.483	0.013	0.517	0.002	1.019	0.003	1.289	0.004	0.780	0.016	0.803	0.002
	b	0.738		1.037		0.496		0.519		1.022		1.293		0.796		0.805	
20	a	1.132	0.008	1.095	0.01	0.675	0.001	0.587	0.004	1.399	0.008	1.349	0.01	0.952	0.001	0.872	0.004
	b	1.124		1.085		0.674		0.583		1.391		1.339		0.953		0.868	
21	a	0.799	0.005	1.323	0.008	0.808	0.001	0.462	0.005	1.063	0.005	1.566	0.008	1.077	0.002	0.750	0.005
	b	0.794		1.315		0.809		0.457		1.058		1.558		1.079		0.745	
22	a	0.854	0.013	1.000	0.006	1.171	0.012	0.226	0.007	1.112	0.012	1.254	0.005	1.426	0.011	0.522	0.008
	b	0.841		0.994		1.159		0.219		1.100		1.249		1.415		0.514	
23	a	0.720	0.006	0.822	0.003	0.776	0.007	0.405	0.001	0.991	0.002	1.085	0.002	1.048	0.006	0.694	0.002
	b	0.726		0.819		0.783		0.406		0.993		1.083		1.054		0.696	
24	a	0.903	0.002	0.995	0.008	0.920	0.001	0.959	0.006	1.162	0.001	1.248	0.006	1.183	0.001	1.225	0.005
	b	0.905		0.987		0.919		0.965		1.163		1.242		1.184		1.230	

Attachment of HRCR Item # 8: Noise Test Data

JFET S/N47 NOISE MEASUREMENT AT 4K										
	Pwr10	Pwr5	Pwr4	Pwr3	Pwr2	Pwr1	Pwr5b	Pwr7	Pwr9	Pwr8
Vdd (V)	2.8	2.8	2.8	2.8	2.8	2.8	2.8	2.8	2.8	2.8
Vss (V)	1.9	1.67	1.63	1.6	1.55	1.5	1.4	1.3	1.25	1.2
Vdd' (V)	2.503	2.527	2.533	2.536	2.542	2.547	2.558	2.569	2.574	2.58
Vss' (V)	-1.61	-1.405	-1.37	-1.343	-1.298	-1.254	-1.165	-1.075	-1.031	-0.987
Idd (mA)	1.138	1.0417	1.0251	1.0124	0.9525	0.97	0.9284	0.8852	0.864	0.8429
Iss (mA)	1.0989	1.003	0.9865	0.9738	0.9911	0.9315	0.8899	0.8471	0.8261	0.805
I (mA)	1.11845	1.02235	1.0058	0.9931	0.9718	0.95075	0.90915	0.86615	0.84505	0.82395
P (mW)	4.60018485	4.0198802	3.9256374	3.8522349	3.731712	3.61380075	3.38476545	3.1562506	3.04640525	2.93902965
	-16	-16	-16	-16	-16	-16	-16	-16	-16	-16
Channel Num	Vn @150 Hz	Vn @150 Hz	Vn @150 Hz	Vn @150 Hz			Vn @150 Hz	Vn @150 Hz	Vn @150 Hz	Vn @150 Hz
Channel: 1	6.65	6.73	6.41	6.81	5.70	9.04	6.68	7.77	7.04	8.03
Channel: 2	8.44	7.41	7.23	7.85	5.74	8.31	8.75	10.56	15.57	16.93
Channel: 3	7.08	7.01	7.11	6.66	7.22	7.48	8.37	13.40	14.11	21.39
Channel: 4	6.82	7.45	6.31	6.82	6.86	7.13	8.76	12.10	13.91	15.47
Channel: 5	6.68	6.33	6.98	6.42	6.47	6.85	6.98	7.43	10.34	10.90
Channel: 6	13.34	19.33	23.12	20.60	21.27	23.60	21.37	27.50	32.11	39.33
Channel: 7	9.75	10.20	11.39	10.84	9.48	11.13	8.65	8.94	9.11	8.72
Channel: 8	6.71	6.45	5.99	6.46	5.66	6.13	6.68	5.89	6.18	6.32
Channel: 9	5.23	6.12	6.28	5.20	5.37	4.93	6.38	7.71	8.89	9.56
Channel: 10	6.96	6.44	7.60	7.38	6.57	6.54	6.66	6.69	6.69	7.65
Channel: 11	9.06	8.69	9.18	9.33	10.85	11.07	14.39	12.95	18.49	23.20
Channel: 12	5.84	7.75	8.44	9.65	11.90	15.97	16.51	16.30	13.24	13.94
Channel: 13	7.15	10.14	9.15	9.77	9.04	10.00	10.32	13.00	15.12	14.76
Channel: 14	7.26	7.83	7.19	7.66	6.55	6.06	6.65	8.50	10.33	12.69
Channel: 15	7.94	10.92	11.29	13.64	16.76	17.85	32.45	51.29	72.99	77.29
Channel: 16	6.57	9.07	8.49	10.68	13.40	13.99	22.57	23.34	25.80	23.64
Channel: 17	7.28	6.36	7.16	5.69	6.04	6.97	9.10	8.48	9.56	9.74
Channel: 18	8.17	6.04	6.43	6.49	6.43	7.30	7.22	9.65	12.77	18.16
Channel: 19	11.33	12.41	10.33	11.30	12.02	10.20	10.63	12.72	14.47	17.43
Channel: 20	7.85	6.99	6.93	7.44	6.16	6.76	6.11	6.83	7.10	6.96
Channel: 21	7.91	6.25	7.31	7.35	7.32	8.36	10.23	19.16	27.26	31.56
Channel: 22	8.51	12.97	16.00	15.94	17.53	15.40	13.03	12.89	13.31	10.79
Channel: 23	7.21	6.13	5.85	7.35	7.76	5.39	7.43	8.62	7.90	10.95
Channel: 24	7.15	6.41	6.89	6.75	6.98	7.76	9.05	10.90	14.07	14.16
Median	7.24	7.21	7.21	7.41	7.10	8.03	8.76	10.73	13.28	14.05
Overall Mean	7.79	8.39	8.71	8.92	9.13	9.76	11.04	13.44	16.10	17.90
Good Mean	7.79	7.92	7.72	8.07	7.79	8.07	8.60	9.74	10.53	10.37
MP Req'd		15	15	15	15	15	15	15	15	15
Yield	1.00	0.96	0.92	0.92	0.88	0.83	0.83	0.79	0.71	0.58
# Good Ch.	24	23	22	22	21	20	20	19	17	14
# Bad Ch.	0	1	2	2	3	4	4	5	7	10

JFET_Mod21_brd47_Noise_perfEIDP.xls

Attachment of HRCR Item # 8: Test Data - Source Voltage & Noise

JFET S/N53 NOISE MEASUREMENT AT 4K											
	Pwr4	Pwr2	Pwr3	Pwr1	Pwr5	Pwr5b	Pwr7	Pwr9	Pwr8	Pwr10	Pwr11
Vdd (V)	2.8	2.8	2.8	2.8	2.8	2.8	2.8	2.8	2.8	2.8	2.8
Vss (V)	-2	-1.9	-1.85	1.8	-1.75	-1.65	-1.5	-1.55	-1.45	-1.35	-1.3
Vdd' (V)	2.435	2.45	2.457	2.464	2.471	2.484	2.5	2.5	2.514	2.529	2.537
Vss' (V)	-1.639	-1.554	-1.511	-1.468	-1.425	-1.339	-1.254	-1.253	-1.169	-1.083	-1.04
Idd (mA)	1.399	1.344	1.3164	1.2883	1.2608	1.2051	1.1491	1.149	1.0932	1.0364	1.0082
Iss (mA)	1.3721	1.3172	1.2896	1.2618	1.2342	1.1788	1.123	1.1228	1.0672	1.0107	0.9826
I (mA)	1.38555	1.3306	1.303	1.27505	1.2475	1.19195	1.13605	1.1359	1.0802	1.02355	0.9954
P (mW)	5.6447307	5.3277224	5.170304	5.0134966	4.86026	4.55682485	4.2647317	4.2630327	3.9783766	3.6970626	3.5605458
	-16	-16	-16	-16	-16	-16	-16	-16	-16	-16	-16
Channel Num	Vn @150 Hz		Vn @150 Hz		Vn @150 Hz	Vn @150 Hz	Vn @150 Hz	Vn @150 Hz	Vn @150 Hz	Vn @150 Hz	Vn @150 Hz
Channel: 1	7.69	6.25	7.55	6.72	7.40	6.60	5.65	7.28	5.09	6.91	6.37
Channel: 2	7.30	7.23	6.22	5.90	6.15	5.54	5.65	6.00	7.37	9.87	9.80
Channel: 3	7.52	7.10	7.26	6.56	6.00	6.31	9.61	8.92	17.31	24.55	26.36
Channel: 4	10.18	11.72	15.21	17.27	15.36	17.67	13.21	14.85	12.51	10.66	8.70
Channel: 5	7.35	5.97	6.35	5.36	7.28	5.55	5.85	6.12	7.44	9.69	10.37
Channel: 6	6.72	6.39	6.49	6.15	6.01	6.40	6.78	6.91	7.32	9.77	13.89
Channel: 7	5.67	6.35	6.90	8.19	7.84	11.33	24.22	23.21	42.32	50.59	49.86
Channel: 8	10.37	9.63	8.42	8.43	8.67	8.55	8.64	9.33	11.47	11.86	12.96
Channel: 9	10.27	13.14	13.10	16.76	19.59	28.91	35.95	34.67	38.56	61.78	82.48
Channel: 10	6.37	5.84	5.92	5.66	5.87	6.07	9.60	10.93	17.82	50.40	66.88
Channel: 11	5.48	5.02	5.19	5.48	6.08	7.01	10.15	10.60	13.26	12.31	14.06
Channel: 12	7.25	7.36	6.70	6.12	7.08	10.78	16.40	16.18	19.72	30.33	42.21
Channel: 13	6.07	6.06	6.05	6.79	6.86	10.00	14.91	15.48	29.93	24.33	27.34
Channel: 14	6.19	7.17	5.03	6.67	6.67	6.83	9.95	8.99	10.90	15.40	21.54
Channel: 15	6.37	6.34	6.67	6.88	6.04	9.19	9.43	7.58	8.05	11.28	13.89
Channel: 16	8.16	10.92	10.81	13.70	13.46	19.88	22.23	23.26	23.15	23.79	31.11
Channel: 17	6.47	5.61	6.58	6.69	5.23	6.53	7.64	5.87	5.27	6.72	6.24
Channel: 18	6.38	6.99	5.14	6.54	5.61	6.83	7.92	9.06	12.34	22.24	23.84
Channel: 19	11.53	10.34	11.43	13.10	13.06	10.70	10.98	9.63	9.87	10.90	10.95
Channel: 20	8.05	6.41	5.65	5.73	6.98	6.47	5.86	6.86	5.82	5.62	5.84
Channel: 21	10.28	6.43	6.06	6.81	6.03	6.06	6.41	6.45	5.31	7.89	10.28
Channel: 22	7.15	7.64	8.23	8.10	6.65	7.32	7.49	7.95	13.04	25.90	31.48
Channel: 23	8.96	8.42	9.05	11.61	12.80	13.88	22.22	22.40	26.13	30.62	33.14
Channel: 24	9.85	7.58	6.82	7.54	4.90	5.67	5.58	5.58	6.30	7.02	8.98
Median	7.32	7.05	6.68	6.76	6.77	6.92	9.52	9.02	11.91	12.09	13.98
Overall Mean	7.82	7.58	7.62	8.28	8.23	9.59	11.76	11.84	14.85	20.02	23.69
Good Mean	7.82	7.58	7.29	7.49	7.39	7.79	8.49	8.27	8.83	9.27	10.18
MP Req'd					15						
Yield	1.00	1.00	0.96	0.92	0.92	0.88	0.79	0.75	0.67	0.54	0.54
# Good Ch.	24	24	23	22	22	21	19	18	16	13	13
# Bad Ch.	0	0	1	2	2	3	5	6	8	11	11
JFET_Mod21_brd53_Noise_perfEIDP.xls											

Attachment of HRCR Item # 9: SPIRE MIUL Cover Page

MIUL = Material Identification & Utilization List

Declared Materials List's and Processes List are not included in this HRCR

Materials and Processes List

SPIRE

JPL D-25725

REV B

1/05/04

This technical data is export controlled under U.S. law and is being transferred by JPL to ESA for use exclusively on the Herschel/Planck projects. The information may not be used for any other purposes, and shall not be re-transferred or disclosed to any other party without the prior written approval of NASA.

Reviewed by:



M. Knopp M&P Engineer

Attachment of HRCR Item # 11:

**See End of This HRCR Package for
“JFET Module Handling Document”**

Attachment of HRCR Item # 14: JFET Module Top Assembly Drawing 10209750-1

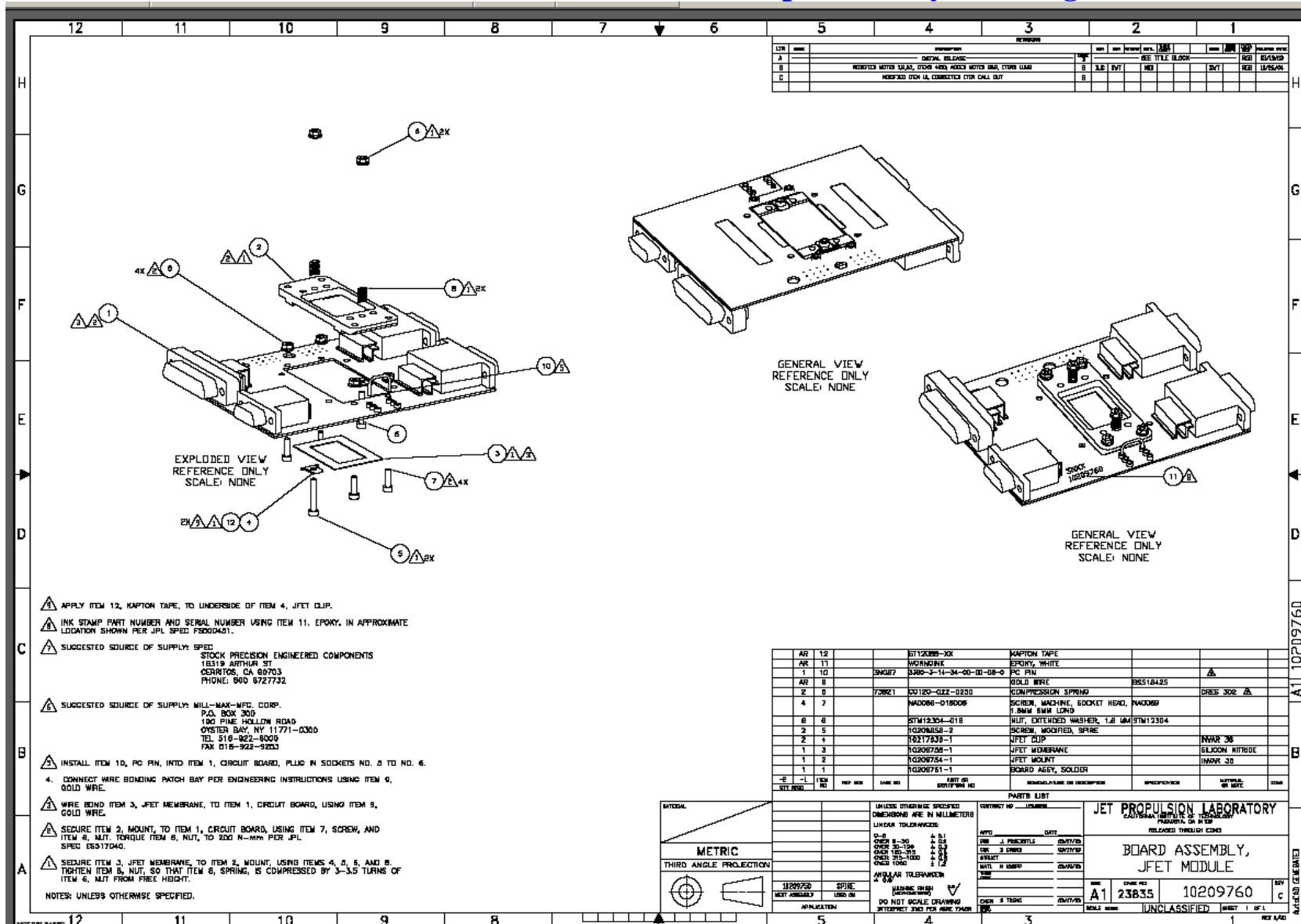

- ▲ APPLY ITEM 12, KAPTON TAPE, TO UNDERSIDE OF ITEM 4, JFET CLIP.
 - ▲ INK STAMP PART NUMBER AND SERIAL NUMBER USING ITEM 11, EPOXY, IN APPROXIMATE LOCATION SHOWN PER JPL SPEC F50010401.
 - ▲ SUGGESTED SOURCE OF SUPPLY: SPED STOCK PRECISION ENGINEERED COMPONENTS 18319 ARTHUR ST. CERRITOS, CA 90703 PHONE: 900 6727732
 - ▲ SUGGESTED SOURCE OF SUPPLY: MILL-MAX-MFG. CORP. P.O. BOX 300 100 PINE HOLLOW ROAD OYSTER BAY, NY 11771-0000 TEL: 516-922-8000 FAX: 516-922-8200
 - ▲ INSTALL ITEM 10, PC PIN, INTO ITEM 1, CIRCUIT BOARD, PLUG IN SOCKETS NO. 3 TO NO. 6.
 - 4. CONNECT WIRE BONDING PATCH BAY PER ENGINEERING INSTRUCTIONS USING ITEM 9, GOLD WIRE.
 - ▲ WIRE BOND ITEM 3, JFET MEMBRANE, TO ITEM 1, CIRCUIT BOARD, USING ITEM 5, GOLD WIRE.
 - ▲ SECURE ITEM 2, MOUNT, TO ITEM 1, CIRCUIT BOARD, USING ITEM 7, SCREW, AND ITEM 6, NUT. TORQUE ITEM 6, NUT, TO 200 N-mm PER JPL SPEC 05017040.
 - ▲ SECURE ITEM 3, JFET MEMBRANE, TO ITEM 2, MOUNT, USING ITEMS 4, 5, 6, AND 8. TIGHTEN ITEM 8, NUT, SO THAT ITEM 6, SPRING, IS COMPRESSED BY 3-3.5 TURNS OF ITEM 6, NUT FROM FREE HEIGHT.
- NOTES: UNLESS OTHERWISE SPECIFIED.

Attachment of HRCR Item # 23: Qualification Compliance Test

Qualification Model JFET Module

EIDP Coverage For JFET Testing

Unit Identification						
Name	:	JFET QM Module				
Part #	:	10209750-1				
S/N	:	#001				
Environmental Testing						
		Axes Tested	Temperature	Duration/# of Cycle	Requirement	Source
Random Vibration Test:		X, Y, Z	100 K	2 min/axis	X, Y, Z	SSSD, JFET-DES-07
High Level Sine Vibe Test		None	NA	NA	X, Y, Z	SSSD, JFET-DES-07
Bakeout		NA	80 C	72 Hours	90C, 72 Hrs	D-20549
Thermal Cycles		NA	RmT to 90 K	27	Minimum 15	D-20549
Performance Characteristics						
			Specification		Source	Waiver
Power needed for <11 bad channels (Min Perf.)	9.1 mW		11 mW for CQM, 7 mW for PFM/FS		SSSD, JFET-TEC-05, JFET-PER-02	RFW in process
Power needed for <4 bad channels (Design Value)	10.8 mW		11 mW for CQM, 7 mW for PFM/FS		SSSD, JFET-TEC-05, JFET-PER-02	
Power needed for 100 % Yield per unit	13.5 mW		NA		NA	
Median Noise at < 11 bad chs.	7.13 nV/rtHz	<15 nV/rtHz			SSSD, JFET-PER-01	
Median Noise at < 4 bad chs.	6.1 nV/rtHz	Min		<7 nV/rtHz	SSSD, JFET-PER-01	
Median Noise at 100 % Yield.	6.97 nV/rtHz	Performance		Design Value	SSSD, JFET-PER-01	
# of Channels over the max. offset voltage	0	< 15 mV for CQM < 15 mV for PFM/FS			SSSD, BDA-DRC J-27	
Common Mode Rejection Ratio	< -60 dB by design, as measured in EM4 unit				SSSD, BDA-DRC J-11	
Board Level Detail						
		Board SN 001			Source	
# Channels Tested	:	24				
Median Noise at 3.5 mW	:	18 nV/rtHz			SSSD, JFET-PER-01	
# of good channels at 3.5 mW	:	7	29% Yield		SSSD, JFET-PER-02	
Power Needed for 100 % Yield	:	6.75 mW			SSSD, JFET-PER-02	
Median Noise at High Power (w/ 100 % Yield)	:	6.97 nV/rtHz			SSSD, JFET-PER-01	
Median Gain at High Power	:	0.98			NA	
Definitions						
Good Channels	:	None less than a min. performance value of 15 nV/rtHz				
Yield	:	# of Good Channels / 24				
Filenames	:					
Noise Measurements	:	QualJFETPostVibeNoise_Summary.pdf				
Notes						
1) The Base temperature for a performance characterization was 4K						
2) All Noise Measurements were made with the inputs shorted to ground						

Attachment of HRCR Item # 24 & #25: Mate/Demate & Operation Logs

Hardware ID	JFET S/N 20, 21						
Date	Time	AIDS	Power	Mate	Demate	Transport	Notes
9-May	8:00 AM	245460				X	103 -> 183
9-May	8:00 AM	245460		X			Mate All Connectors
9-May	8:00 AM	245460					Measure all resistances
9-May	8:00 AM	245460	X				30 min each board, warm S.V. test (green dewar)
9-May	8:00 AM	245460					Assemble into CSF
9-May	8:00 AM	245460			X		Remove all shorting connectors, close out CSF
10-May	8:00 AM	245460				X	183->144
10-May	8:00 AM	245460					Pump out
10-May	8:00 AM	245460					Run 3-axis warm shake
10-May	8:00 AM	245460				X	144->183
10-May	8:00 AM	245460		X			Install shorting connectors
10-May	8:00 AM	245460				X	Remove JFETs from CSF
18-May	8:00 AM	245460		X			Install into blue dewar
18-May	8:00 AM	245460	X				Take source voltage measurements
18-May	8:00 AM	245460			X		Remove from blue dewar, store in flight cabinet
13-Jun	8:00 AM	245595		X			Install into green dewar
13-Jun	8:00 AM	245595					Pump out
13-Jun	8:00 AM	245595	X				30 min each board, warm S.V. test (green dewar)
14-Jun	8:00 AM	245595					Transfer LN2
14-Jun	8:00 AM	245595					Transfer Helium
15-Jun	8:00 AM	245595	X				30 min each board, cold S.V. test (green dewar)
16-Jun	8:00 AM	245595	X				6 hours, board 50 noise
17-Jun	8:00 AM	245595	X				5 hours, board 51 noise
17-May	8:00 AM	245595	X				6 hours, board 47 noise
21-Jun	8:00 AM	245595	X				6 hours, board 53 noise
24-Jun	8:00 AM	245595					warm dewar
27-Jun	8:00 AM	245595					pump out
27-Jun	9:00 AM	245595	X				30 min each board, warm S.V. test (green dewar)
28-Jun	1:00 PM	245595					cool dewar
29-Jun	8:00 AM	245595	X				30 min each board, cold S.V. test (green dewar)
30-Jun	8:00 AM	245595	X				2 hours, board 50, gain and CMRR
30-Jun	10:00 AM	245595	X				2 hours, board 51, gain and CMRR
30-Jun	12:00 AM	245595	X				2 hours, board 47, gain and CMRR
30-Jun	2:00 PM	245595	X				2 hours, board 53, gain and CMRR
30-Jun	6:00 PM	245595					warm dewar
5-Jul	8:00 AM	245595	X				30 min each board, warm S.V. test (green dewar)
6-Jul	8:00 AM	245595			X	X	Demate, Transport 183->103

Attachment of HRCR Item # 24 & #25: Mate/Demate & Operation Logs (continued)

OPERATION LOG SHEET -- SPIRE JFET BOARDS MODULE

DEVICE (BRD) S/N: ^{NEW} 047 (062) PROJECT: SPIRE/JFET BOARD

USE THE "NOTE" COLUMN TO DESCRIBE ACTIONS

DATE	TIME	TECH	PWR ON	PWR OFF	MATE				DEMATE				TRANSFERT	NOTE
					JAA	JBB	JCC	JDD	JAA	JBB	JCC	JDD		
1-24-05	8:00	NAN			✓	✓	✓	✓	-	-	-	-		GND & CHASSIS - SAVERS ON
2-01-05		NAN			-	-	-	-	-	-	-	-		GND & CHASSIS "
2-01-05		NAN	✓	✓	-	-	-	-	-	-	-	-		SOURCE TEST
2-28-05	2:00 PM	NAN			-	-	-	-	-	-	-	-		GND & CHASSIS
2-28-05	2:00 PM	NAN			-	-	-	-	-	-	-	-		CHASSIS
3/9/05	7:00	NAN			-	-	✓	✓	-	-	✓	✓		GND & CHASSIS
3/17/05	2:00	NAN			✓	✓	✓	✓	✓	✓	✓	✓		GND & CHASSIS
3/17/05	2:00	NAN	✓	✓	✓	✓	✓	✓	✓	✓	✓	✓		SOURCE
3/17/05	2:00	NAN			✓	✓	✓	✓						SAVERS ON
4/29/05		NAN			-	-	-	-	-	-	-	-		GND & CHASSIS
4/29/05		NAN	✓	✓	-	-	-	-	-	-	-	-		SOURCE TEST
5/2/05		BOB/NAN							✓	✓	✓	✓		REMOVE SAVER
5/3/05		NAN			✓	✓	✓	✓			✓	✓		GND & CHASSIS
5/3/05		NAN	✓	✓			✓	✓	✓	✓				SOURCE
5/5/05		NAN			✓	✓	✓	✓			✓	✓		GND & CHASSIS
5/5/05		NAN	✓	✓			✓	✓	✓	✓				SOURCE TEST

NOTE: CONNECTOR ARE REUSED, FROM DEVICE S/N: 038, BRD S/N: 043

Attachment of HRCR Items # 24 & # 25: Mate/Demate & Operation Logs

OPERATION LOG SHEET -- SPIRE JFET BOARDS MODULE

DEVICE (BRD) S/N: 053 (067) PROJECT: SPIRE/JFET BOARD USE THE "NOTE" COLUMN TO DESCRIBE ACTIONS

DATE	TIME	TECH	PWR ON	PWR OFF	MATE				DEMATE				TRANSFERT	NOTE
					JAA	JBB	JCC	JDD	JAA	JBB	JCC	JDD		
3/2/05		103199			✓	✓	✓	✓	✓	✓	✓	✓		
3/3/05		103199			✓	✓	✓	✓	✓	✓	✓	✓		GND & CHASSIS TEST
3/14/05		103199			✓	✓	✓	✓	✓	✓	✓	✓		INSTALL SAVERS
3/15/05		103199			✓	✓	✓	✓	✓	✓	✓	✓		GND & CHASSIS "
3/15/05		103199	✓	✓	✓	✓	✓	✓	✓	✓	✓	✓		GND & CHASSIS "
3/17/05		103199	✓	✓	✓	✓	✓	✓	✓	✓	✓	✓		SOURCE TEST
4/27/05		103199			✓	✓	✓	✓	✓	✓	✓	✓		SOURCE TEST
4/27/05		103199	✓	✓	✓	✓	✓	✓	✓	✓	✓	✓		GND & CHASSIS
5/2/05		BOB/NOLY			✓	✓	✓	✓	✓	✓	✓	✓		SOURCE TEST
5/3/5		NAN			✓	✓	✓	✓	✓	✓	✓	✓		REMOVE SAVER
5/3/5		NAN	✓	✓	✓	✓	✓	✓	✓	✓	✓	✓		GND & CHASSIS
5/5/5		NAN			✓	✓	✓	✓	✓	✓	✓	✓		SOURCE
5/5/5		NAN	✓	✓	✓	✓	✓	✓	✓	✓	✓	✓		GND & CHASSIS
														SOURCE

Attachment of HRCR Item # 26: MICD - JFET Interface Drawing 10209722 (p 1 of 2)

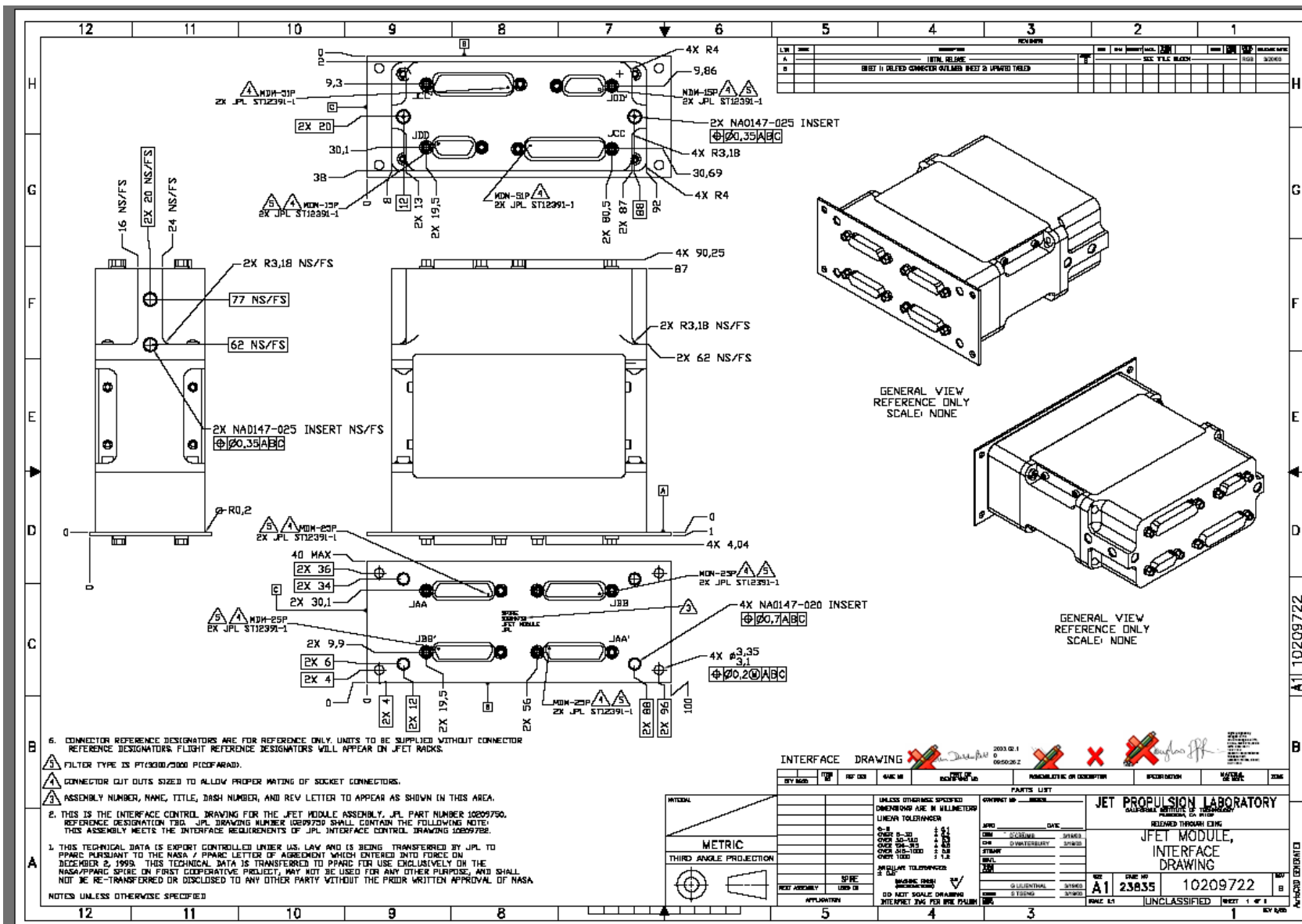

Attachment of HRCR Item # 26: MICD - JFET Interface Drawing 10209722 (p 2 of 2)

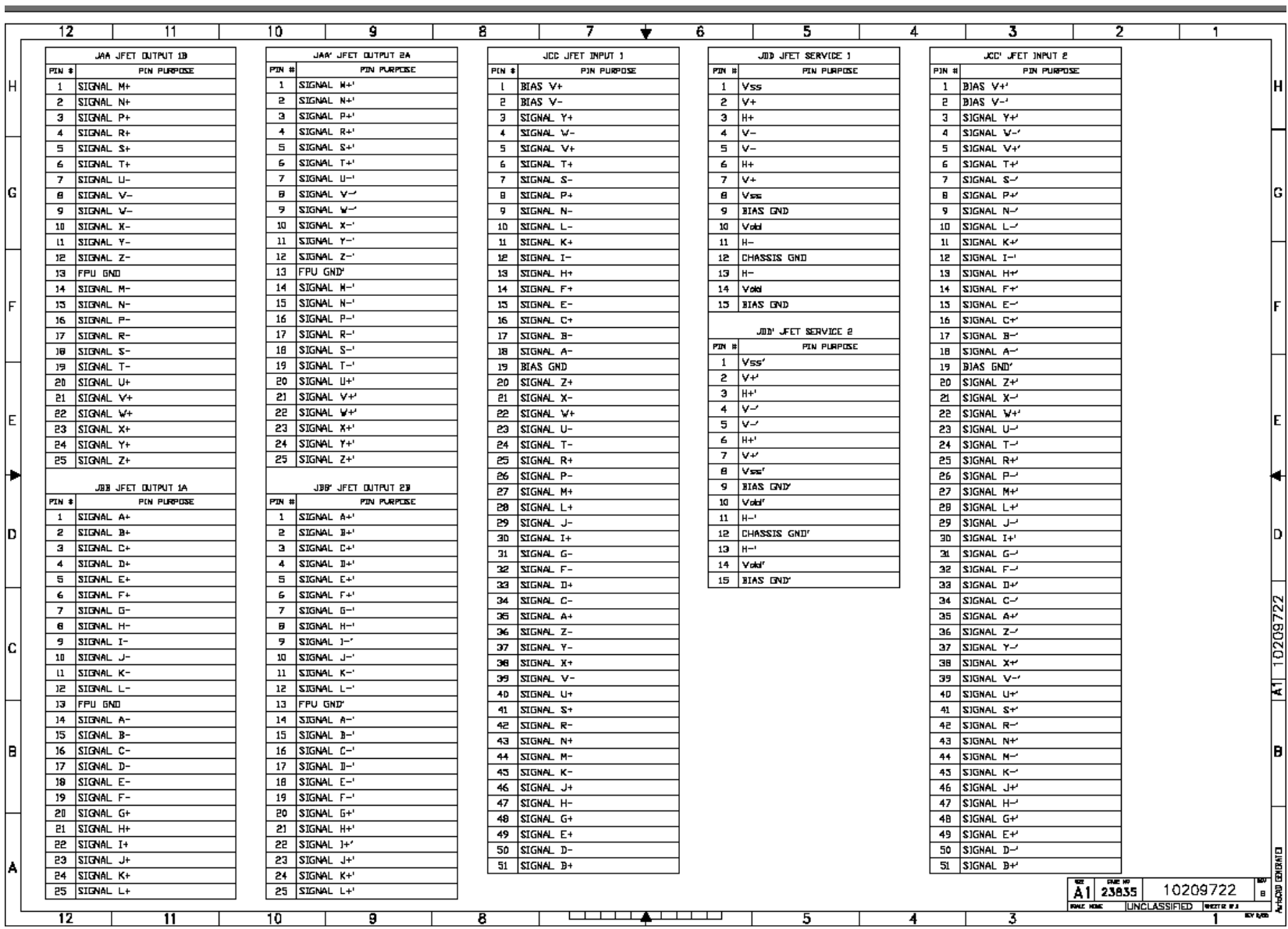

Attachment of HRCR Item # 11:

JFET Module

Handling Document D-26790

Field Effect Transistor (JFET) Module 10209750-1

Prepared by: Kalyani Sukhatme 10 September, 2003

Revised by: Roger Welker & Steve Tseng 11 August, 2005

1. Introduction

This document provides guidelines for electrical handling of bench top testing for the SPIRE JFET Module.

1.1 Hardware Description

Each JFET module has two sets of 24 JFET channels. The JFET channels are populated on 1.0 micron thick Silicon Nitride membranes which provides thermal isolation. The operating temperature for these JFETs is ~120 K. The process of powering up the JFETs dissipates heat into the membrane resulting in a temperature increase with respect to the base temperature (4K to 10 K). Higher the power dissipation, higher is the temperature of the JFETs.

Each JFET channel consists of a matched pair of FETs (Figure 1.1-1) with a requirement for the offset voltage of less than **15 mV** between the matched pair. [The characteristic offset voltage is the difference between the source voltages (V_{sa} and V_{sb} with respect to ground) of the two FETs.]

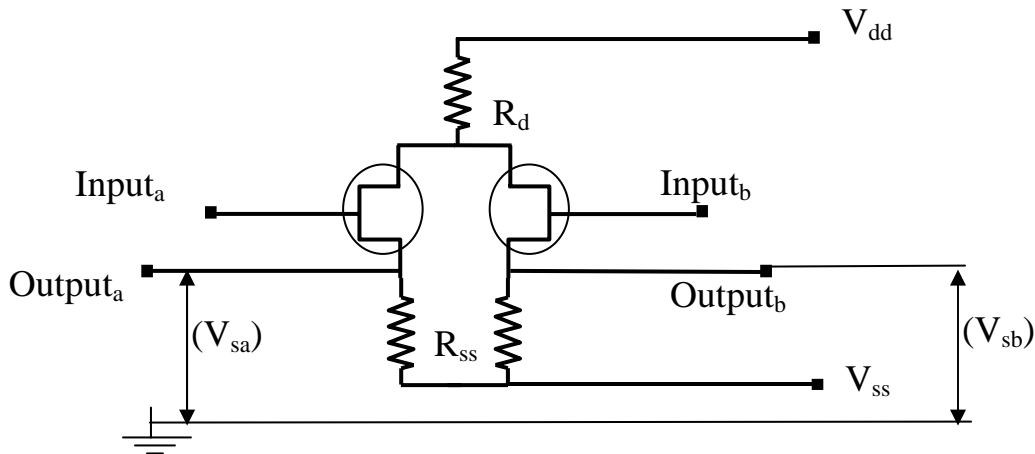

Figure 1.1-1

The Gates of the JFETs are the ‘Inputs’ of the circuit and the Sources (V_{sa} and V_{sb}) of the JFETs are the outputs, as marked in Figure 1.1-1. V_{dd} and V_{ss} are the power lines for the circuit.

2. Handling

1. **The JFET Module is Contamination Sensitive:** Open shipment suitcase in an ISO 14644 Class 7 (FED-STD-209 Class 10,000) or cleaner cleanroom. Handle hardware with approved¹ nitrile or polyurethane ESD safe cleanroom gloves.

¹ JPL approved ESD safe cleanroom gloves are:

Nitrile:

Ansell-Edmont Nitrilite

<http://www.ansellpro.com/ce/products3.asp?pid=87>

Ansell-Edmont Nitrilite Silky

<http://www.ansellpro.com/ce/products3.asp?pid=149>

Ansell-Edmont Silky Ultra-Clean

<http://www.ansellpro.com/ce/products3.asp?pid=150>

Safeskin Critical (white)

http://www.safeskin.com/crit_nt_glv.asp

Polyurethane:

Wilshire Technology DuraCLEAN call in US, 323-259-6469 for ordering information

D-26790

2. The JFET Module is ESD Sensitive:

Please handle with appropriate ESD hardware handling procedures. Handle with grounding straps, ESD-safe gloves, ESD smocks at an ESD-safe workstation.

ESD: Handle with approved² wrist straps, ESD-safe gloves and ESD smocks at an approved ESD protected workstation³. All personnel within 1 meter of unprotected ESD sensitive hardware shall be certified for ESD awareness⁴. Maintain shorting plugs on the unit at all times, except when the unit is installed in the final assembly of the SPIRE instrument. JFET modules are shipped with two shorting plugs for ESD protection. Refer to attached electrical handling document for other important safety precautions. Follow all instructions for the use of wrist straps, ESD smocks, static protected work areas, ionizers, packing/unpacking and cable handling per JPL standard D-1348, rev. F (This document is available through the public domain by the following URL: http://acquisition.jpl.nasa.gov/rfp/miri/dewar/DL-2671-584331/JPL_D-1348.pdf).

ESD - Ionizer: Prior to mate or demate of any connector, turn on an ionizer approved⁵ for ESD sensitive components in clean room environment at least 5 minutes in advance and place/hold both sides of the connections in front of the ionized air stream for a minimum of 10 seconds before mating/demating operation. Position the ionizer near the hardware within the required distance per manufacturer's manual. Different makes and models of ionizers have different positioning requirements. During the mating/demating operations, it is necessary to follow the requirements for handling ESD sensitive hardware.

ESD - Connection to GSE: It is essential to ensure that all signal and bias lines of the GSE are grounded prior to mating the JFET hardware to the GSE. A save-to-mate check must be performed prior to connecting the JFET to the GSE. No excessive voltages and currents on all signal and bias lines shall be observed while the hardware is connected.

QA Oversight: Quality Assurance personnel should witness all handling, electrical testing, operation and integration of JFET flight hardware. At a minimum, a "two person" rule should be invoked at all times, where oversight by an independent party is provided to ensure hardware safety during handling, test and integration operations.

Humidity Sensitive: Place hardware in a humidity controlled ISO 14644 Class 7 (FED-STD 209 Class 10,000) cleanroom. Maintain humidity level at 35%-50% RH typical, for ESD safety.

² JPL approved wrist straps are:

- Speidel Twist-o-Flex™ brand metal expansion bracelet wrist straps
- 3M model 4600 adjustable molded thermoplastic wrist straps

³ All work areas shall be certified and operated in compliance with the requirements of the following subsections sections of JPL-STD D-1348 rev. F section 2.3: subsections: 6, 8-11, 14-19, 21, 23 – 27, 29 – 36, 38 – 43 and 45.

⁴ All personnel shall be trained and certified to the requirements of section 2.3.3 of JPL STD_D-1348 rev. F.

⁵ The ionizer performance shall be verified to comply with the requirements of JPL-STD-D-1348 rev. F, Table 1 for devices with human body model ESD sensitivity less than 50 volts. The ionizer shall discharge from ± 1000 volts to less than ± 20 volts in less than 20 seconds and have a float potential of less than ± 20 volts.

3. **The JFET Module is Fragile:** Please do not drop or otherwise shock the unit including the shipping suitcase and container. Do not remove the cover of the JFET Module.

D-26790

3. Power ON Procedure For Bench Top Testing Only

1. The JFET Module should be powered on **WITH the shorting plugs** (JPL Supplied Protection connectors) in place and with the **inputs shorted to ground**. Pins #9 and #15 on the 15-pin MDM connectors on the JFET Module are the bias grounds on the module. These pins should also be shorted to the power supply ground. Follow the approved RAL power-on procedure when connecting the inputs to the detector system.

Under no circumstances the unit should be powered up without the inputs shorted to ground either via the shorting plug (JPL Supplied) or via the detector system.

2. Do not exceed a voltage of +5 V for the Vdd line and -5 V for the Vss line of the JFET Module.
3. When removing the shorting plugs from the unit for installation into the instrument, please use standard ESD precautions including grounding straps, ESD-safe gloves, ESD smocks at an ESD-safe workstation.

4. Electrical Check-out Test: Characteristic Offset Voltage Measurement For Bench Top Testing Only

- 1) Verify that the gates of the JFET channels (Inputs) are shorted together and grounded.
- 2) Apply the power supply ground to the bias ground pins on the unit (Pins 9 and 15 on the 15-pin MDM connectors)
- 3) Power on the JFET modules with Vdd = +3 V and Vss = -1.5 V
- 4) Verify that the handheld multimeter is in calibration.
- 5) Connect one side of the handheld multimeter to ground (Power supply ground).
- 6) And measure the voltage with respect to ground of each side (V_{sa} and V_{sb}) of each channel.
- 7) Calculate the characteristic offset voltage (V_{offset}) for each channel ($V_{offset} = V_{sa} - V_{sb}$)
- 8) Compare the values for each of the channels with the specific datasheet provided with the unit. The datasheets accompanying the unit also provides the values for the drain and source currents for a similar test performed at JPL.

REFER TO MEASURED SOURCE VOLTAGE DATA FOR ACTUAL HARDWARE. Here is an example of the source voltage values and the drain and the source currents obtained for such a test at room temperature are given in the Table 4-1

T, JFET	rm T
Vdd	3 V
Vss	-1.5 V
Idd	1.564 mA
Iss	1.5686 mA

Channel #	(V)	DELTA (V)
1	1.130	0
	1.130	
2	1.075	0.001
	1.074	
3	0.781	0.001
	0.780	
4	1.088	0.005
	1.093	
5	0.834	0.001
	0.833	
6	1.012	0.003
	1.015	
7	0.785	0.002
	0.787	
8	1.148	0.004
	1.144	
9	0.753	0
	0.753	
10	0.693	0.008
	0.701	
11	1.110	0.004
	1.114	
12	0.758	0.001
	0.759	
13	0.832	0.002
	0.830	
14	1.264	0.001
	1.265	
15	1.206	0
	1.206	
16	0.818	0.001
	0.819	
17	0.526	0.005
	0.521	
18	1.423	0
	1.423	
19	0.773	0.002
	0.775	
20	0.873	0.004
	0.877	
21	1.387	0.006
	1.393	
22	1.417	0.003
	1.420	
23	0.887	0.002

	0.889	
24	0.888	0.003
	0.891	

- END OF -

**Attachment of HRCR Item # 11:
“JFET Module Handling Document D-26790”**

END OF
HRCR PACKAGE