

JPL Hardware Requirements
Certification Review (HRCR)-
Proto-Flight Model (PFM)
Photometer Medium Wavelength PMW)
Bolometer Detector Assembly (BDA)
10209800-2 S/N 012

SPIRE Element
Herschel Space Observatory Project

December 16, 2004

CONTENTS

	SECTION
Hardware Requirements Certification Review (HRCR) Form	1
Final Inspection Report (IR)	2
Issues	3
M. Herman 15 May 2003 memo (fasteners for vibe. tests)	
Top Level Assembly Drawings	4
ECRs / NCRs	5
HR-SP-JPL-ECR-003 (Spectrometer BDA envelope height)	
HR-SP-JPL-ECR-005 (Kapton Cable routing design error)	
HR-SP-JPL-NCR-005 (PMW and PSW focal position shift)	
Waivers	6
HR-SP-JPL-RFW-005 (Sine Vibe Omission)	
HR-SP-JPL-RFW-006 (Vibration Test Levels)	
HR-SP-JPL-RFW-008 (Time Constant Test Omission)	
Open Problem / Failure Reports (PFR)	7
This Hardware: (None)	
Similar Hardware: (None)	
Handling Documents	8
General / Unpacking	
Electronic	
Environmental Requirements Verification Matrix	9
Performance Data Matrix	10
Qualification Status	11
Connector Mate and Operation Logs	12
Mechanical & Electrical ICDs	13
Other Data	14
Detector Backshort Data	
Alignment Measurement Summary	
Feedhorn Data	
300mK Spectrometer Filters EIDP	

RAL EIDP Table Of Contents Vs. HRCR Contents

EIDP Section	EIDP	HRCR Box #	Comments/Notebook Section
1	Shipping Documents		Shipper and Final IR
2	Transportation, Packing, Handling & Integration Procedures	20	Section 8
3	Certificate of Conformance / Delivery Review Board MoM		HRCR form is the CofC
4	As Built Configuration Status List	1	
5	List of Waivers	16	Section 6
6	Copies of Waivers	16	Section 6
7	List of Non-Conformance Reports	17, 18	Section 5
8	Copies of Non-Conformance Reports	17, 18	
9	Cleanliness Statement	10	Final IR includes inspection for conformance with cleanliness requirement (particulates)
10	Operational Manual	20	
11	Top Level Drawings (inc. Family Tree)	14	Section 4
12	Interface Drawings	26	Section 13
13	Functional, Block & Mechanical Drawings	14	Section 4
14	Electrical Circuit Drawings		See Electrical Handling Doc.
15	Serialized Components List		In the build books – not shipped
16	Mass Properties/ Power Budget		Mass found in header of HRCR
17	Qualification Status List / Test Matrix	22	Qual. Report to be supplied later, Summary in Section 11
18	Test Reports		To be supplied later, Summaries in Sections 9 and 10
19	Open Work / Deferred Work / Open Tests	5	
20	Calibration Data		Section 10
21	Historical Record		Section 12
22	Manufacturing Logbook(s)	--	To be retained at JPL
23	Operating Time / Cycle Record	24	Section 12
24	Connector Mating Record	24	Section 12
25	Age Sensitive Items Record		NA for BDA
26	Pressure Vessels – History/Test Record		NA
27	Temporary Installation Record		Section 12
28	Reference List of EIDPs (Lower level)		300mK Filter EIDP - Section 14
29	Other Useful Information		Section 14

JPL Hardware Requirements Certification Review – SPIRE Element

#D-31101

Assembly/Subsystem		PEM			Phone		Section		Date	
SPIRE		Martin Herman			(818) 354-8541		386		16 December, 2004	
Drawing/ Part No.	Dwg. Rev.	Nomenclature		Serial No.	Model	Type	Final IR No.		Mass (grams) As Meas. / Req.	
10209800-2	B	Bolometer Detector Assembly		012	PFM	PMW	923807		603 g / 632 g	
Check applicable answer and give necessary explanation in remarks column			Y	N	N / A	Remarks		Data Attachments (Package Sec. #)		Signature Approval & Date
1. Are all drawings and specifications complete, approved, released and frozen?			x			<p>See section 3 matrix for which drawings are released.</p> <p>First hardware of this type delivered</p> <p>All Requirements met except as shown in attached verification matrix (section 10) and Issues / NCRs (section 4). See section 11 for detector performance matrix.</p> <p>Official Indentured Parts List (IPL) not generated due to drawing status, but traceability information is captured in build books.</p> <p>Thermal time constant measurement was not completed. See attached request for waiver (section 7).</p>		14. Latest Top Assembly Drawings <input checked="" type="checkbox"/> Attached <input type="checkbox"/> None (Sec. 5)		Cog E
2. Do the released drawings and specifications reflect all approved changes?			x					15. List of open ECRs <input checked="" type="checkbox"/> Attached <input type="checkbox"/> None (Sec. 6)		PEM
3. Is hardware identical to other hardware delivered? If no, provide difference list.					x			16. Waivers <input checked="" type="checkbox"/> Attached <input type="checkbox"/> None (Sec. 7)		QA Engineer
4. Does the hardware meet the requirement of its functional requirements, specifications, waivers and/or ICDs ? If no, provide difference list.				x				17. Open MRBs <input type="checkbox"/> Attached <input checked="" type="checkbox"/> None (N/A)		Environments/Reliability
5. Have all IR discrepancies and MRBs been dispositioned and agreed to by Engineering/ QA ?			x					18. Open P/FRs on this H/W <input type="checkbox"/> Attached <input checked="" type="checkbox"/> None (Sec. 8)		Mission Assurance Mgr.
6. Is complete as-built list information included in the build book?			x					19. Open P/FRs on similar H/W <input type="checkbox"/> Attached <input checked="" type="checkbox"/> None (Sec. 8)		Project
7. Have all required environmental tests & analyses been completed?			x					20. Handling Document <input checked="" type="checkbox"/> Attached <input type="checkbox"/> None (Sec. 9)		PI
8. Is all required assembly and/or subsystem level functional testing complete?				x				21. Shortage List <input type="checkbox"/> Attached <input checked="" type="checkbox"/> None (N/A)		
9. Have all piece parts, processes and materials been approved by JPL?			x					22. Requirements Verification Matrix <input checked="" type="checkbox"/> Attached <input type="checkbox"/> None (Sec. 10)		
10. Does this hardware meet all contamination control requirements?			x					23. Qualification Status <input checked="" type="checkbox"/> Attached <input type="checkbox"/> None (Sec. 12)		
11. Are all required shipping containers, shipping procedures, and special handling procedures ready?			x					24. Connector Mate / Demate Log <input checked="" type="checkbox"/> Attached <input type="checkbox"/> None (Sec. 13)		
12. Is additional work required to bring this hardware to flight readiness?				x				25. Operation Log <input checked="" type="checkbox"/> Attached <input type="checkbox"/> None (Sec. 13)		
13. Is this hardware acceptable for flight ?			x					26. ICDs <input checked="" type="checkbox"/> Attached <input type="checkbox"/> None (Sec. 14)		



*** INSPECTION REPORT ***
 Printed Copies are for Reference Only - Please
 check with PDMS for official version

IR Number
923807

Action
 BROWSE

Status
 "Pending IR
 Action
 for
 IRDI's"
[IR Instructions](#)

REFERS TO:

Part Number	Dash Number	Revision	Latest Rev	Serial Number	Quantity
10209800-2	(with part number)	A	B	012	1

Nomenclature:	BOLOMETER DETECTOR ARRAY				
Prgm/Project:	HSO-PLANCK	Inspection Date:	20-SEP-2004		
COGE:	WEILERT, MARK A.	ECO/ECI:			
QAE:	HUGHES, SCOTT P.	Reference Designator:	SPIRE		
JPL/Mfr:	JPL	Lot No.:			
Type of Inspection:	Final-Ship	Insp. Std / Spec No.:			
Type of Item:	Flight	AIDS No.:			
Location:	JPL	Work Order No.:			
Manufacturer:		CAGE Code:	23835		
Supplier:		Receipt No.:			
Parts received by:		Property / ID:			
Received date:		PO/CT No.:			
Qty Accepted:		Line No.:			
Qty Rejected:	0	Rel / Mod No.:			
QA Alert?		CAN Required?			
IMTE Code:	None	IMTE Number:			
IMTE Code No. 2:	None	IMTE Number No. 2:			
IMTE Code No. 3:	None	IMTE Number No. 3:			
IMTE Code No. 4:	None	IMTE Number No. 4:			
Orig Nomenclature:					

DISCREPANT ITEMS:

Item	Discrep Code	Qty	Zone	S/N	Description	Re-Work	Files
1	2D8	1	N/A	012	parts were assy. to unreleased dwg.	-	No
2	2D8	1	N/A	012	The following IR'S are still open for unreleased dwg. see below	-	No

Item	Disposition	Root Cause Code	Dispo Code	Disp. Appr.	Stamp Date
1	top level drawing, 10209800 has been released, rev B, incorporating new spacer ring.	-	ACC	16-DEC-2004 HUGHES, SCOTT P.	16-DEC-2004 HUGHES, SCOTT P.
2	IR's are open due to unreleased drawings. Drawings will be released	-	SA	16-DEC-2004 HUGHES, SCOTT P.	<input type="checkbox"/> Stamp <input type="checkbox"/> Demote

Inspection Report Notes:

part was assembled to aids # 243673

10209860-1 IR 922872
 10209820-1 IR 923616
 10209903-1 IR 922922

	Initiated by HUGHES, SCOTT P.	Signed by COGE WEILERT, MARK A.	Signed by QAE HUGHES, SCOTT P.	Closed by
Number of Files Attached 0	Date 02-DEC-2004	Date 16-DEC-2004	Date 16-DEC-2004	Date
Reserved by	Reserved on	Reason		

Issues

PFM PMW BDA 10209800-2 S/N 012

Configuration / Processing:

Several ECRs related to this hardware have been incorporated into released drawings. They are included for reference:

- The maximum height of 300 mK stage exceeds ICD drawing 10209721 allowed range by 1.0 mm due to changes in 300 mK filter stack thickness which were not incorporated into the drawing. See attached ECR: HR-SP-JPL-ECR-003 in section 6. This change has been incorporated into Rev-C of the ICD.
- A focus position shift caused by an internal mechanical interference fix was incorporated into ICD drawing 10209721 Rev C per HR-SP-JPL-NCR-005 (attached in in section 6).
- A pixel map modification was incorporated into electrical schematic 10209725 Rev C per HR-SP-JPL-ECR-005 (attached in section 6). This drawing revision also incorporated JPL ECR 1026751.

Environmental Test:

- Shake tests were performed with non-flight-like 8-32 mounting screws, instead of 6-32. See attached email regarding this issue: (M. Herman, 15 May 2003) -- *This same issue applied to the previous CQM-PLW and PFM-SLW BDAs.*
- Shake tests were performed in accordance with open waivers HR-SP-JPL-RFW-005 (Sine Vibration Omission) and HR-SP-JPL-RFW-006 (Vibration Test Levels). See Waiver List (section 7).

Performance Test:

- The thermal time constant measurement was omitted. See attached waiver HR-SP-RFW-008 (in section 7) which requests that the test be performed at the instrument level.

Date: Mon, 11 Aug 2003 16:34:04 -0700
From: Martin Herman <Martin.I.Herman@jpl.nasa.gov>
Subject: Waiver Request (vibration fastners)
X-Sender: miherman@pop.jpl.nasa.gov
To: Mark.A.Weilert@jpl.nasa.gov
Cc: Henry.Abakians@jpl.nasa.gov

Date: Thu, 15 May 2003 11:41:18 -0700
To: Matt Griffin <Matt.Griffin@astro.cf.ac.uk>, Eric Sawyer <e.c.sawyer@rl.ac.uk>, Chris Brockley-Blatt <cbb@mssl.ucl.ac.uk>, Berend Winter <bw@mssl.ucl.ac.uk>
From: Martin Herman <Martin.I.Herman@jpl.nasa.gov>
Subject: Waiver Request (vibration fastners)
Cc: Ben.A.Parvin@jpl.nasa.gov, Jamie Bock <jjb@astro.caltech.edu>, Gary Parks <Gary.S.Parks@jpl.nasa.gov>, kalyani@squid.jpl.nasa.gov
Bcc:
X-Attachments:

Dear Matt and SPIRE Team,

To refresh everyone's memory. We requested the following information:

What type of fasteners will be used in Europe to mount the BDA? In our ICD, 6-32 fasteners are called for. However, the current test hardware uses 8-32 fasteners. We are looking to be consistent with the flight implementation.

The answer (Thanks Chris) was 6-32. Our current test fixture uses 8-32 and we are getting ready for vibration testing of the CQM next week. Therefore, we had a mechanical engineer look into this issue. His (Paul MacNeal) response was:

It will acceptable to use four #8-32 fasteners for the vibration tests at JPL. The reasons are....

- 1) The test fixture has already been built using #8-32 tapped holes,
- 2) The use of #6-32 fasteners torqued to full value should be able to resist over 200 G's of lateral force before allowing slippage, and therefore is not a critical component of the vibration test, and
- 3) The test is primarily performed to verify integrity of the flexures, braid, and other components, and not the interface fasteners.

Based on this information, we are requesting a waiver for the CQM PLW vibration and for future QM, CQM, PFM and FS tests. The change for future test is small, but the fiscal situation is extremely challenging and no technical risk to the program is evident with the existing approach.

Thanks,
Marty

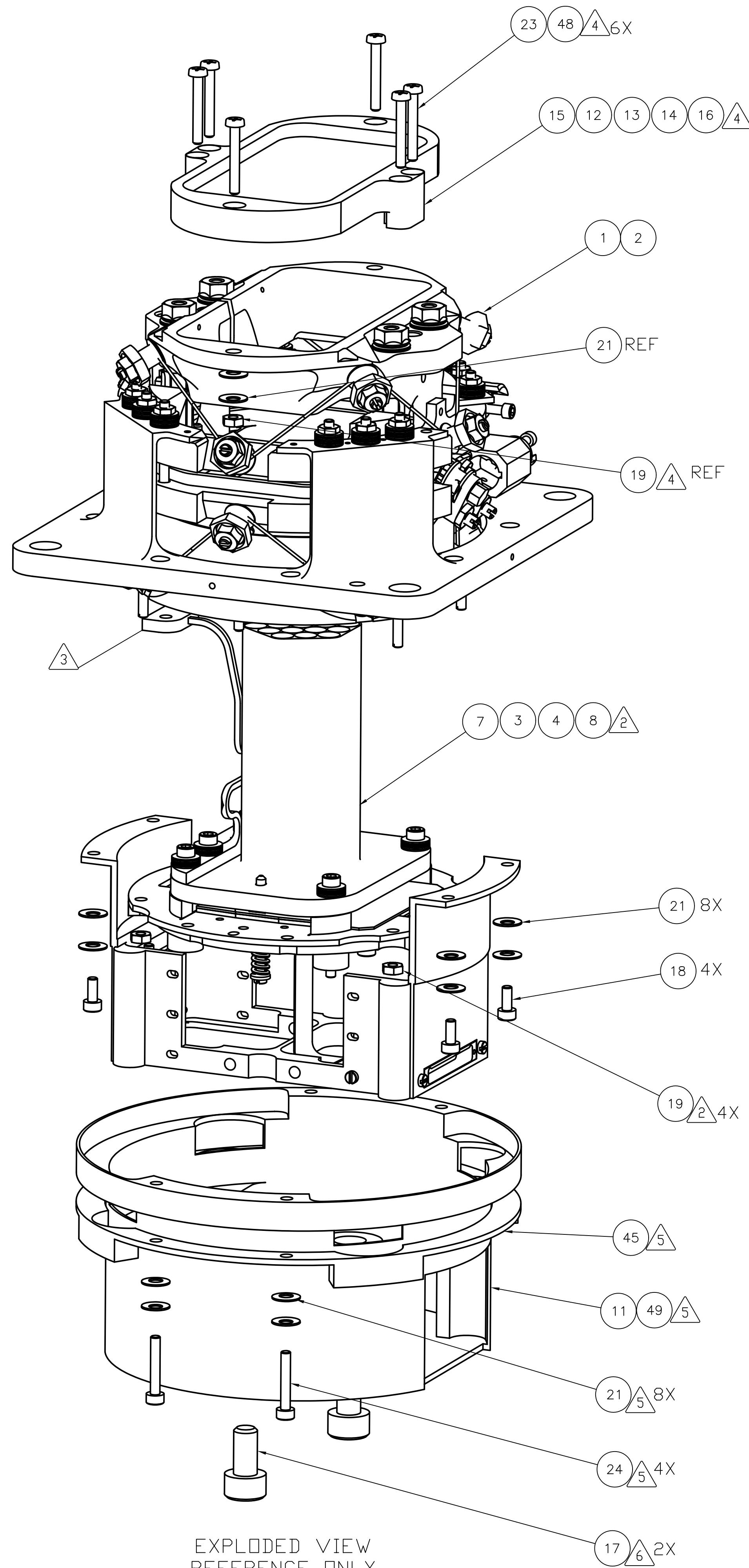

EXPLODED VIEW
REFERENCE ONLY
-4 CONFIGURATION SHOWN
-1, -5 CONFIGURATIONS ARE SIMILAR
-8 CONFIGURATION SIMILAR WITHOUT FILTER

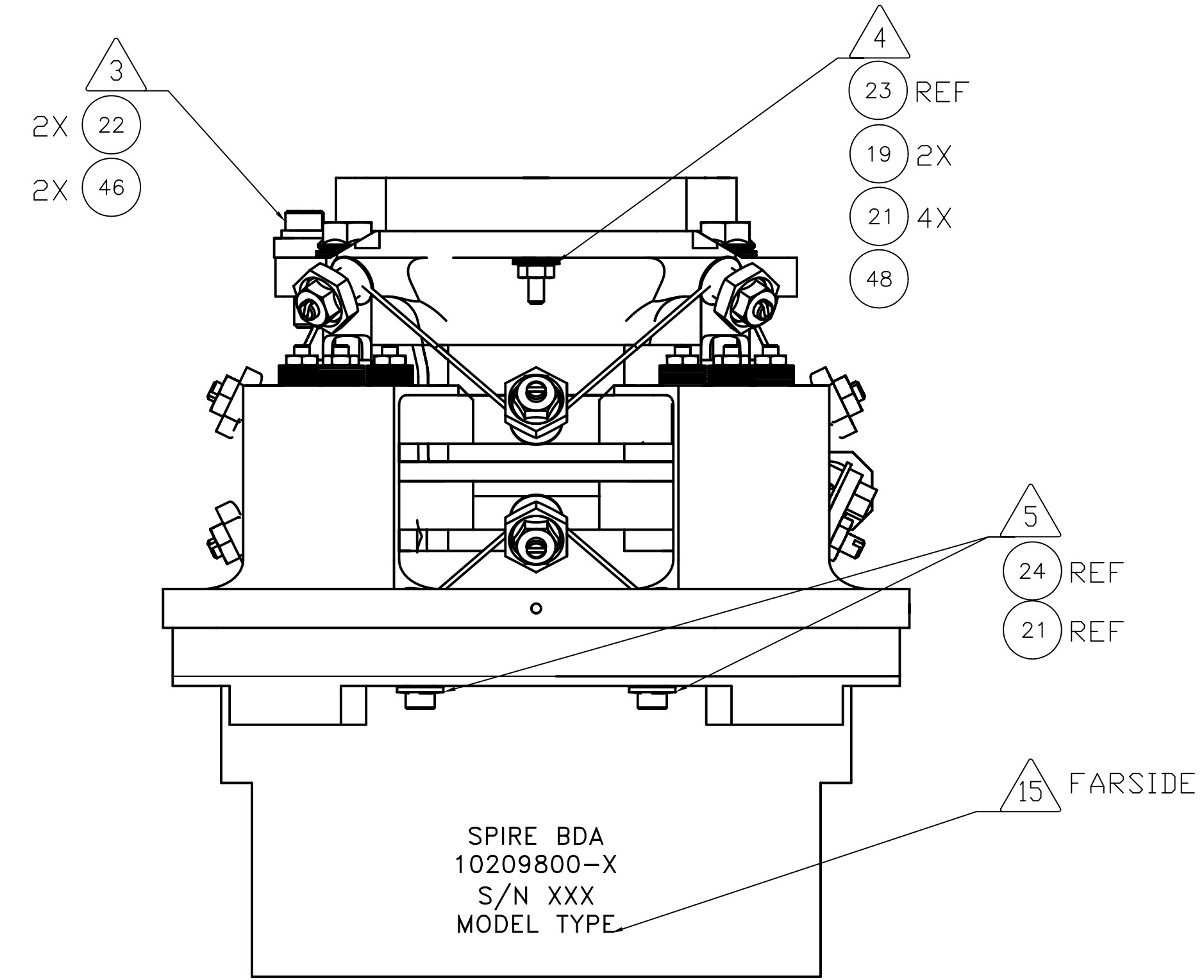

-4 CONFIGURATION SHOWN
-1, -2, -3, -5 CONFIGURATIONS ARE SIMILAR
-8 CONFIGURATION SIMILAR WITHOUT FILTER

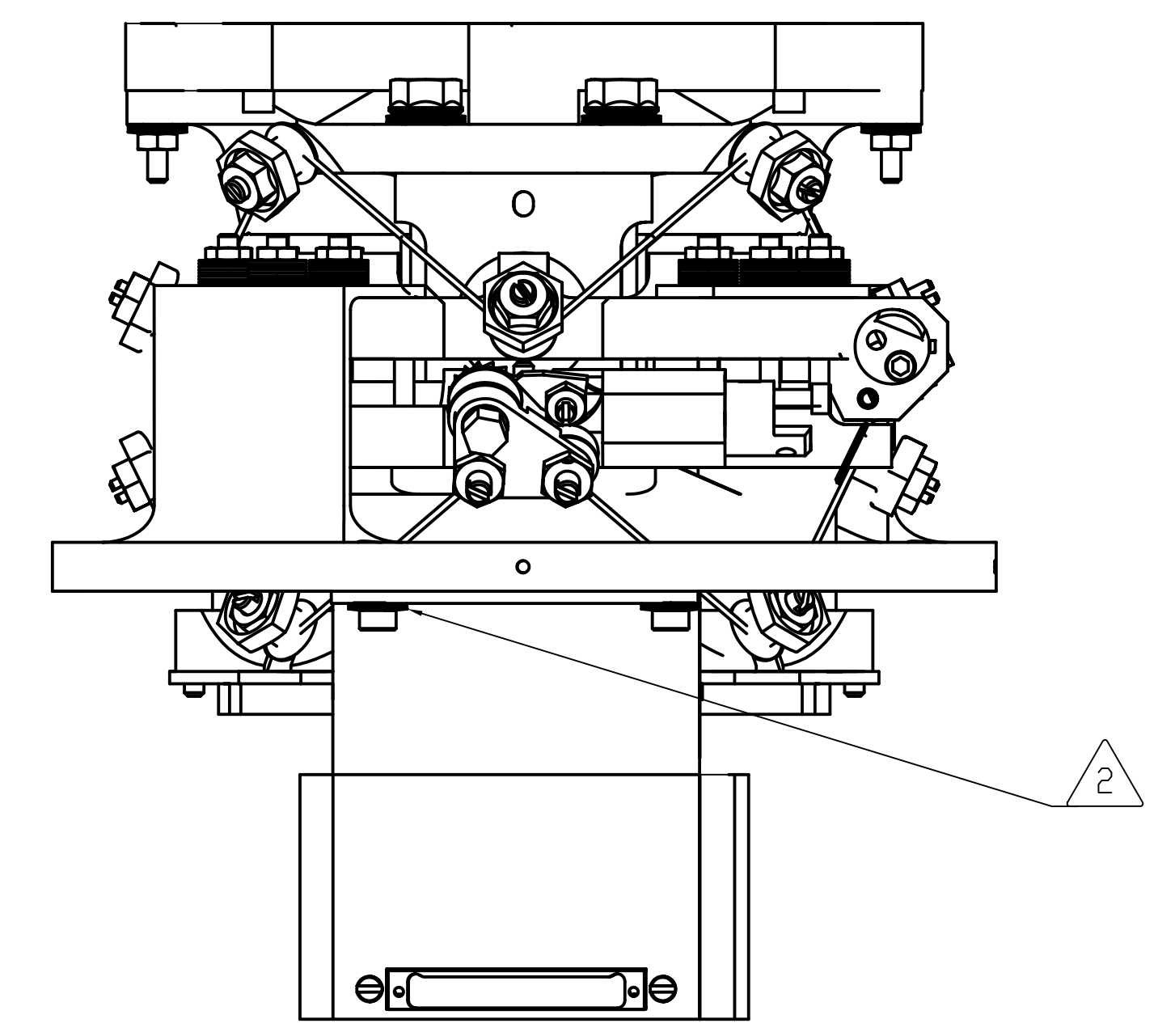

COMPONENTS REMOVED FOR CLARITY
-4 CONFIGURATION SHOWN
-1, -2, -3, -5 CONFIGURATIONS ARE SIMILAR
-8 CONFIGURATION SIMILAR WITHOUT FILTER

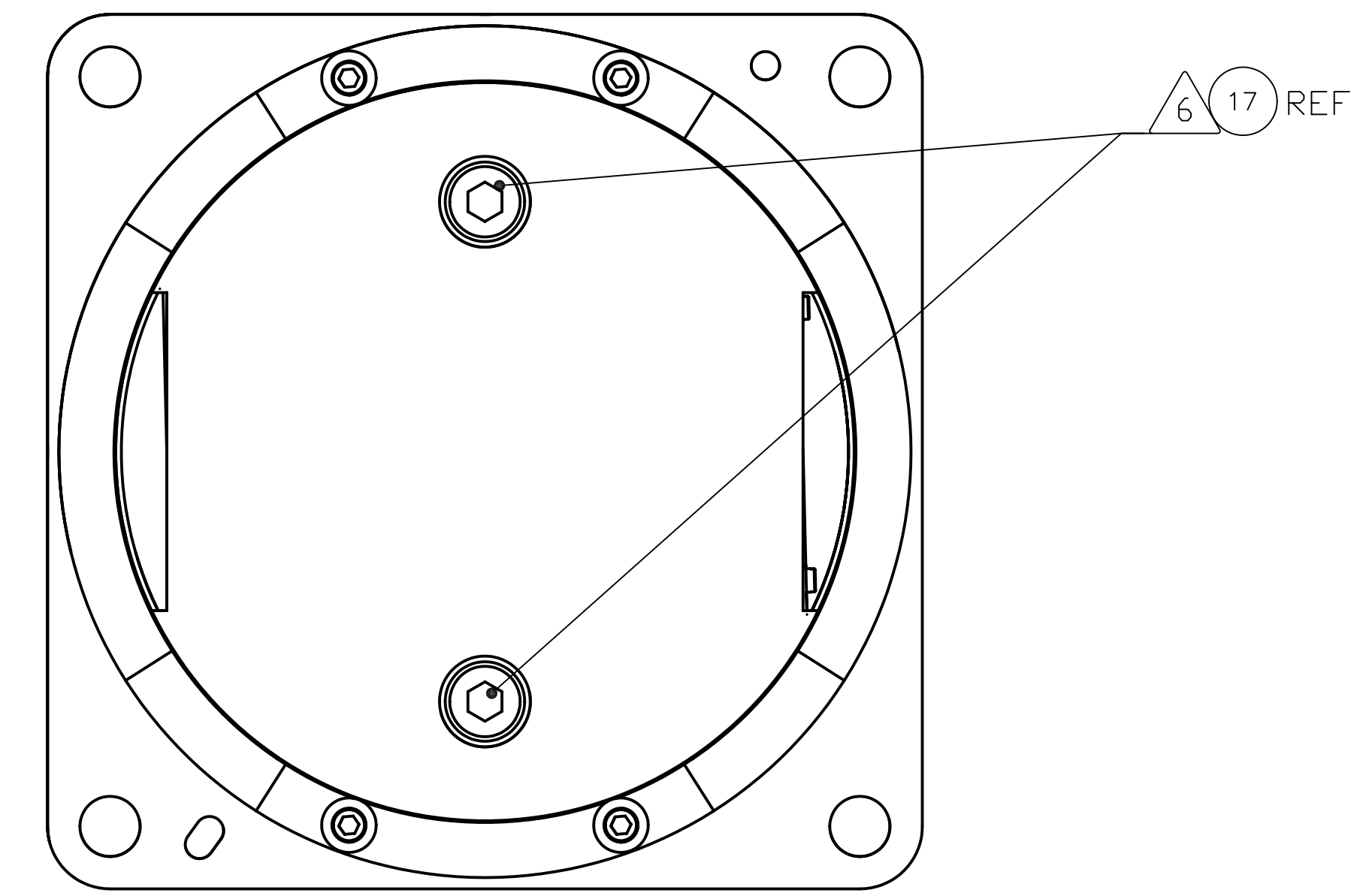

-4 CONFIGURATION SHOWN
-1 AND -5 CONFIGURATIONS ARE SIMILAR
-8 CONFIGURATION SIMILAR WITHOUT FILTER

SIZE	CAGE NO	10209800	REV
A1	23835		B
SCALE	UNCLASSIFIED	SHEET 2 OF 4	REV 2/00

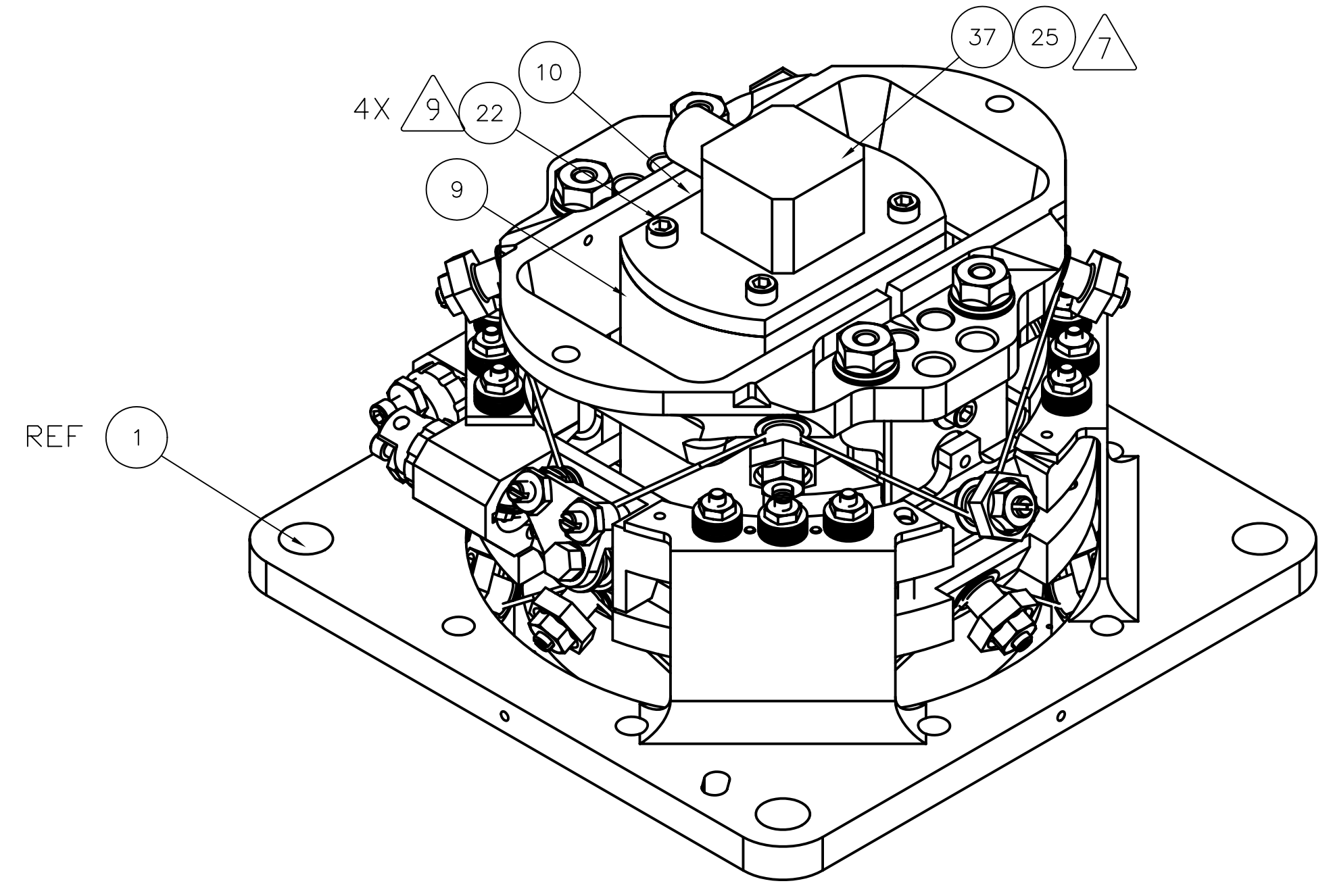
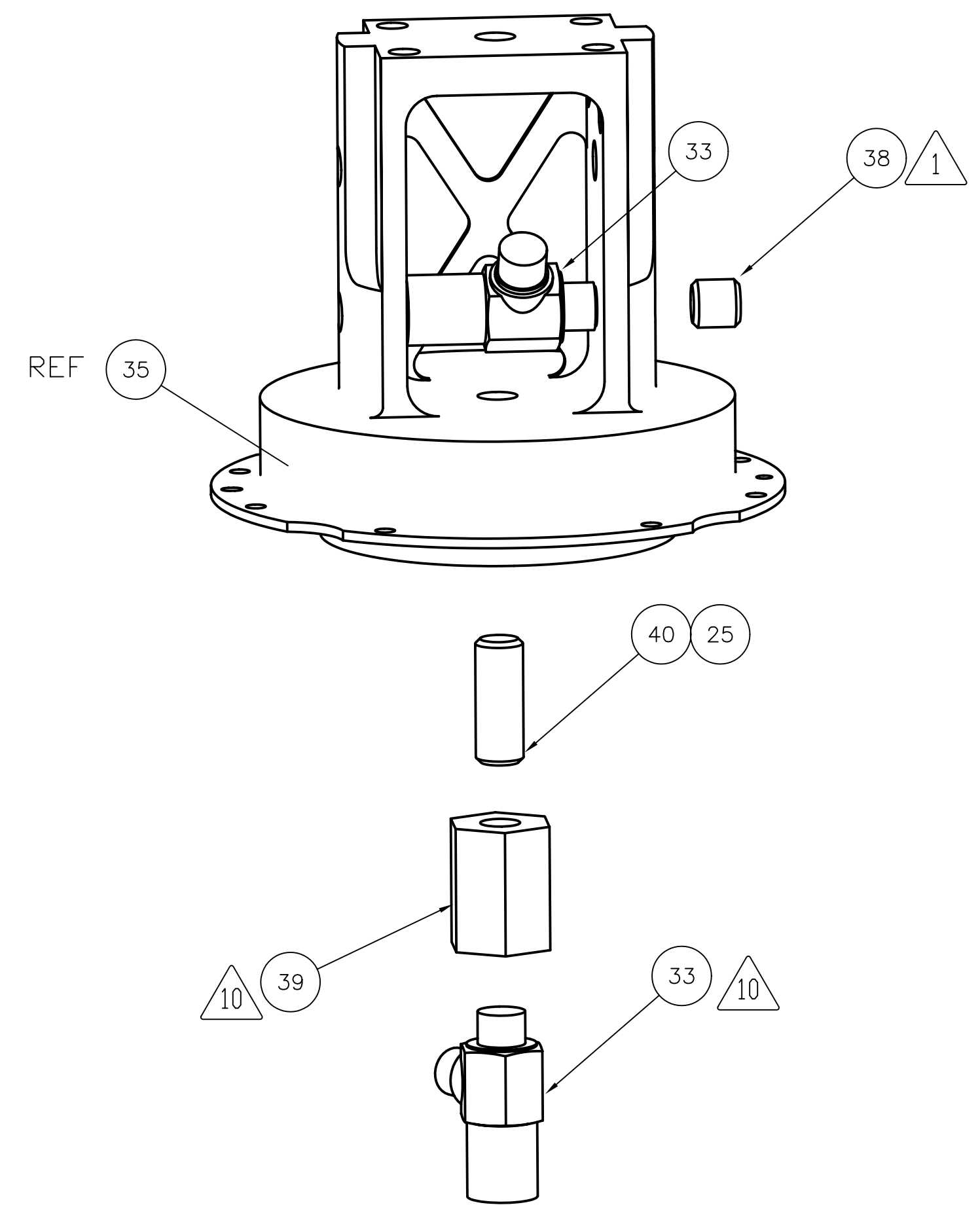
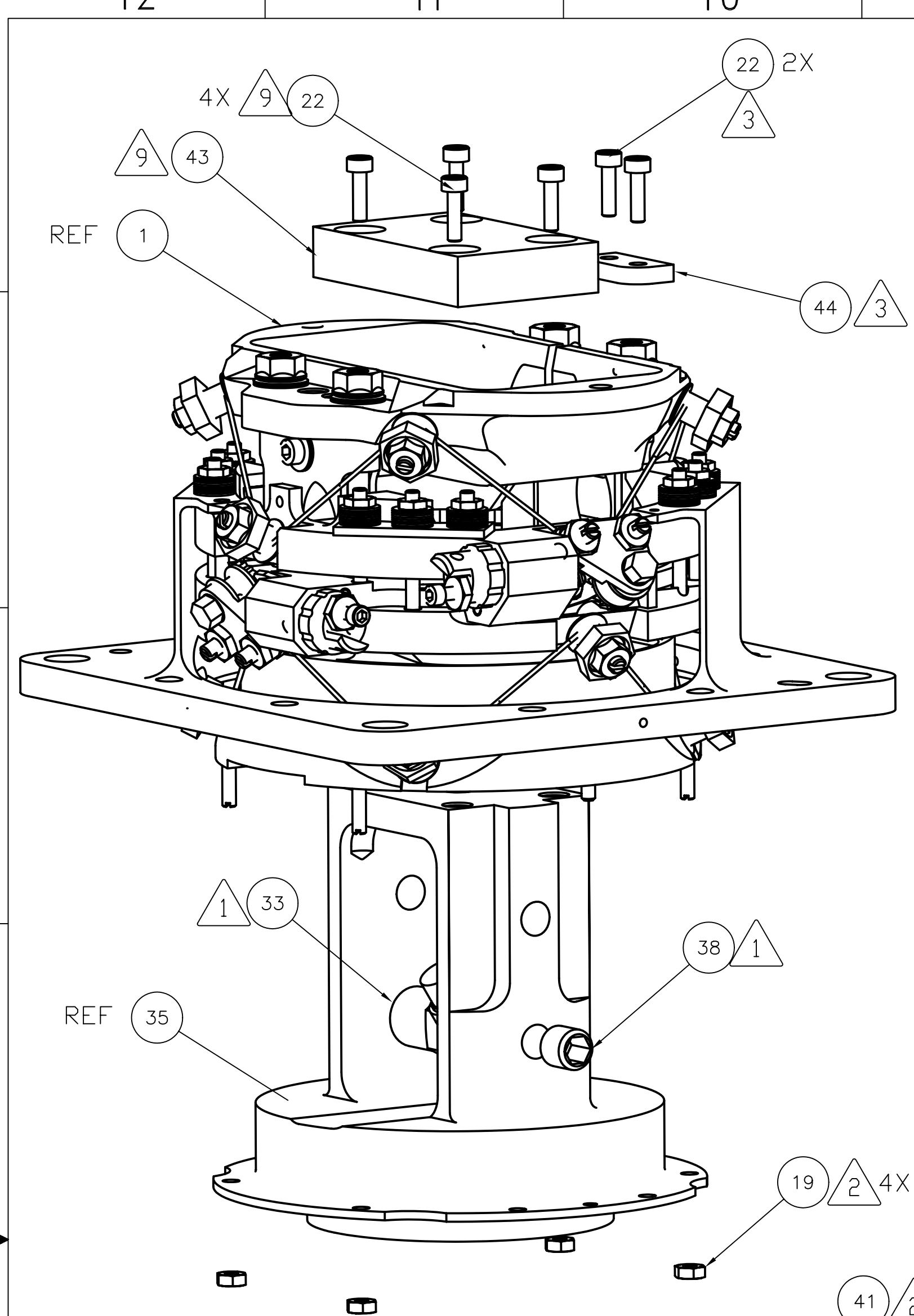

GENERAL VIEW
REFERENCE ONLY
SCALE: NONE
-6 CONFIGURATION

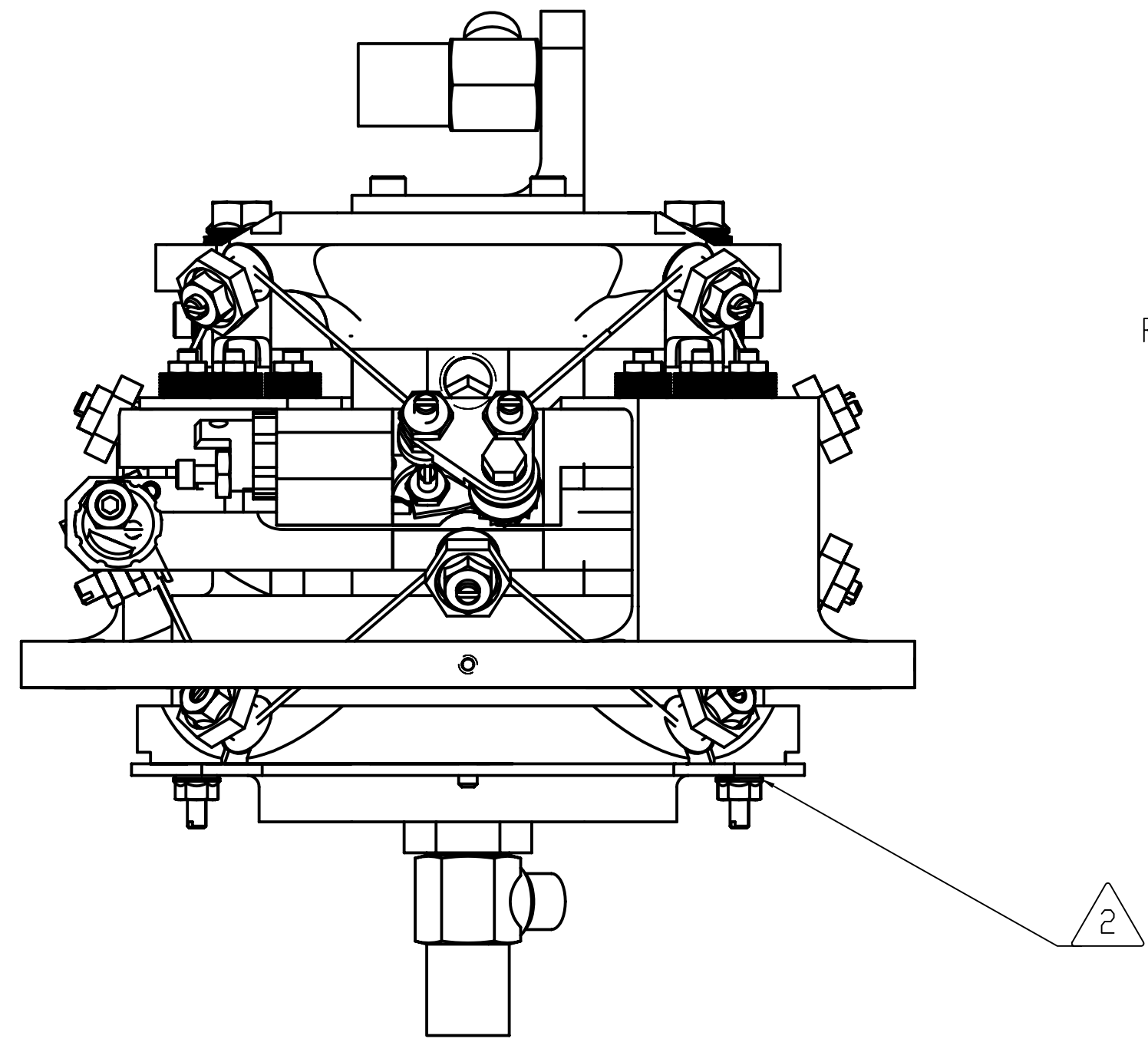
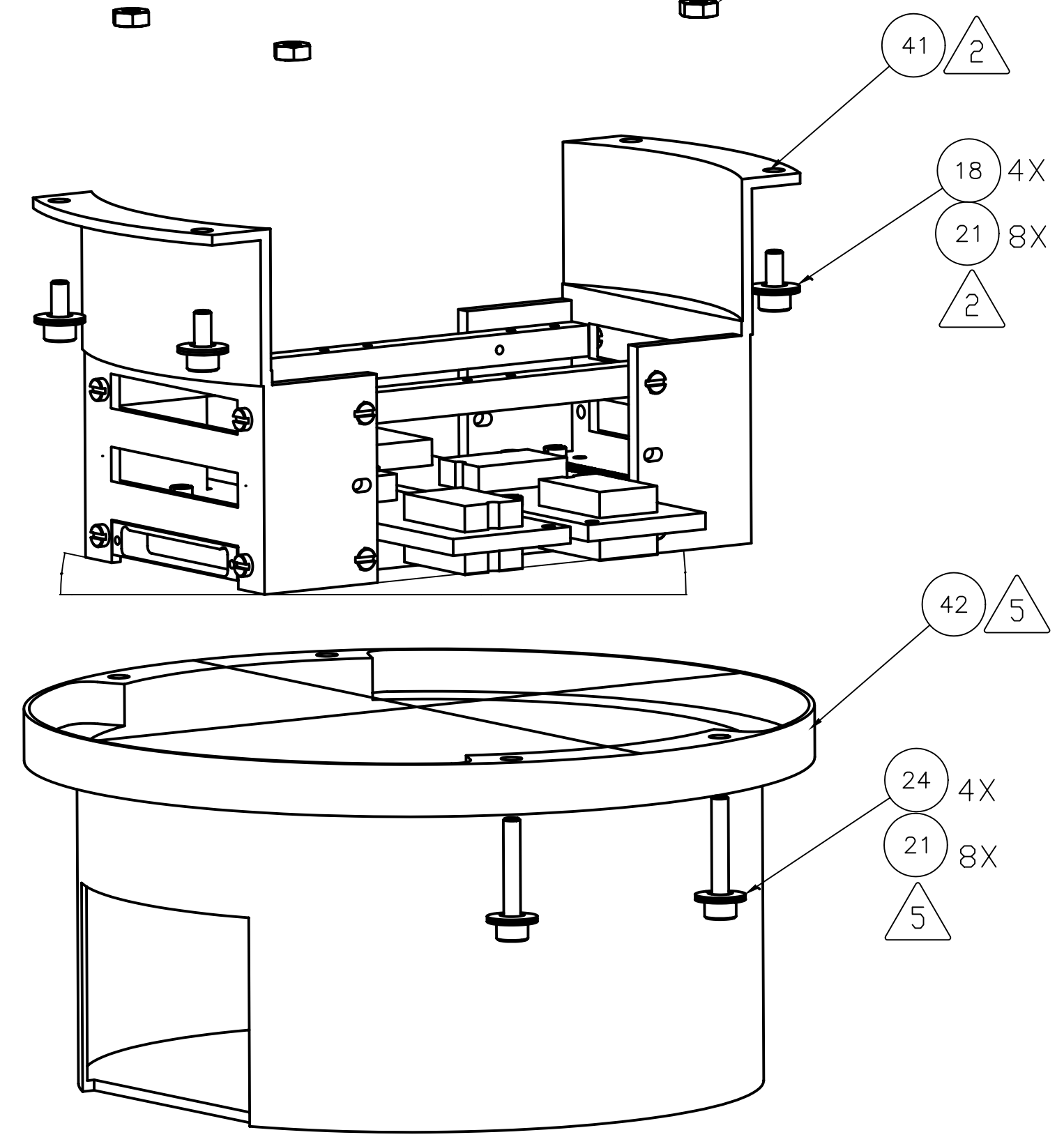

-7 CONFIGURATION

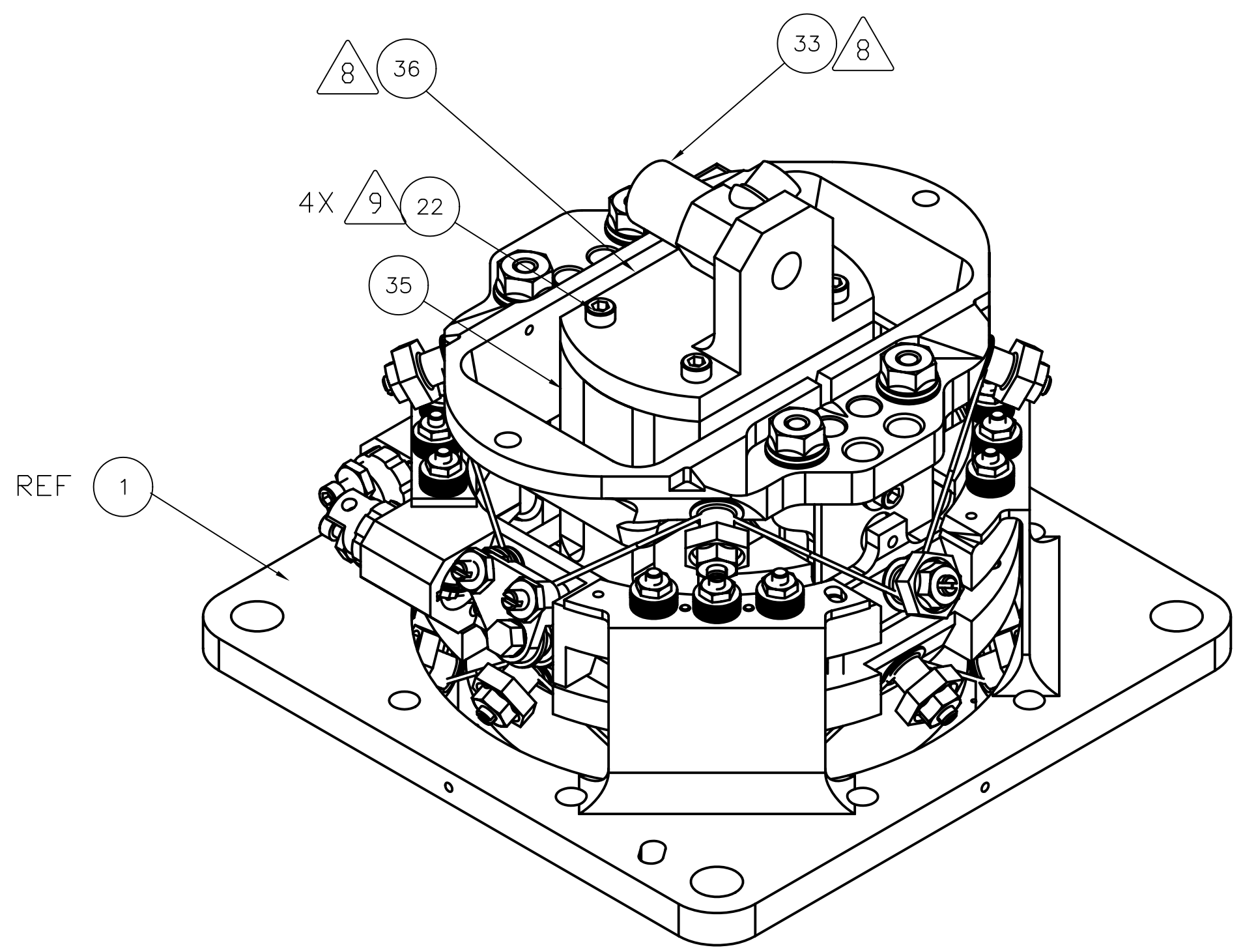

GENERAL VIEW
REFERENCE ONLY
SCALE: NONE
-7 CONFIGURATION

GENERAL VIEW
REFERENCE ONLY
SCALE: NONE
-9 CONFIGURATION,

SIZE	CAGE NO	REV
A1	23835	10209800
SCALE: NONE	UNCLASSIFIED	SHEET 3 OF 4

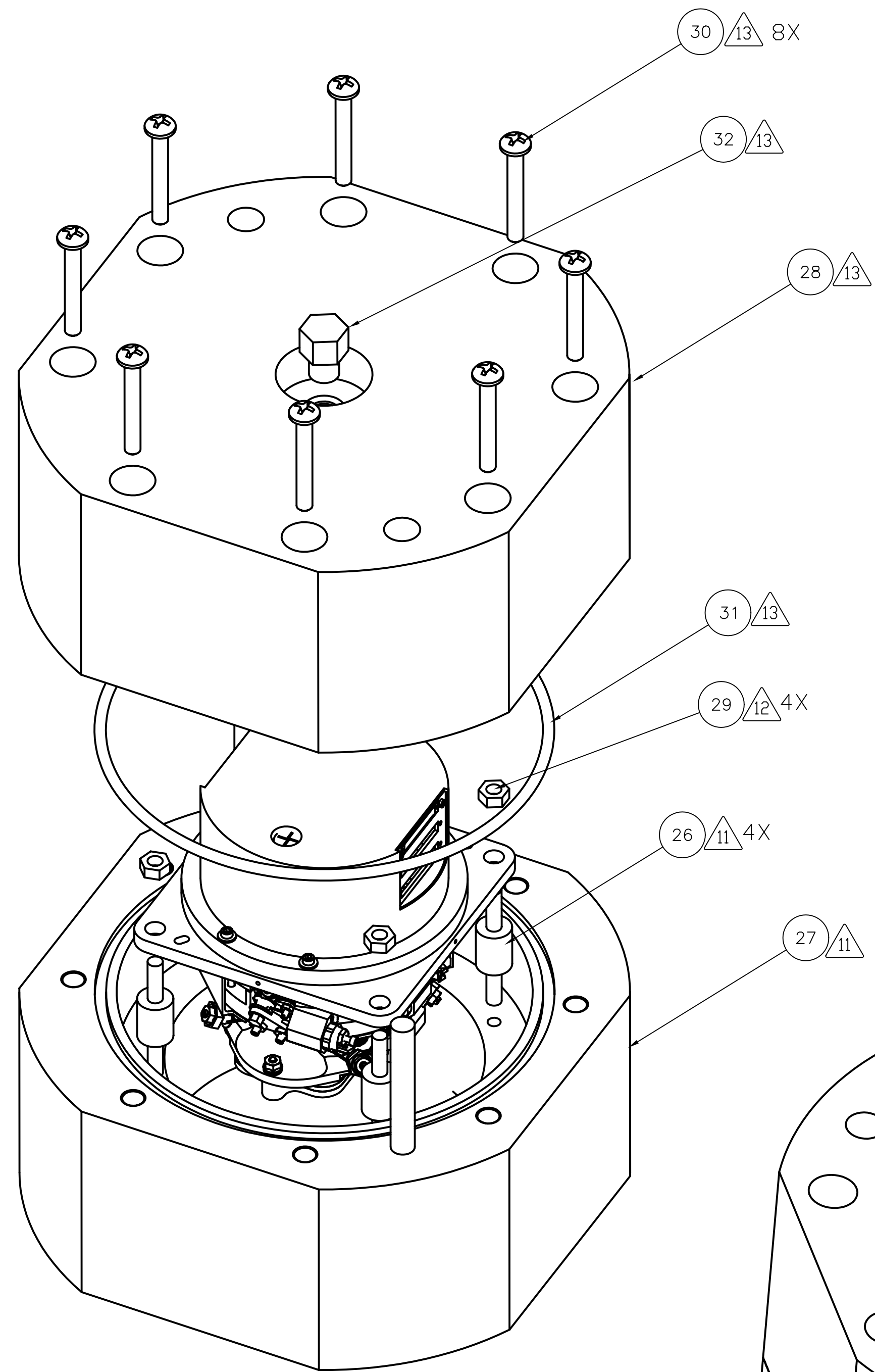

EXPLODED VIEW
 REFERENCE ONLY
 -5 CONFIGURATION
 -1,-2,-3,-4, -8 AND -9 SIMILAR
 -6 AND -7 SIMILAR WITH NO CAN

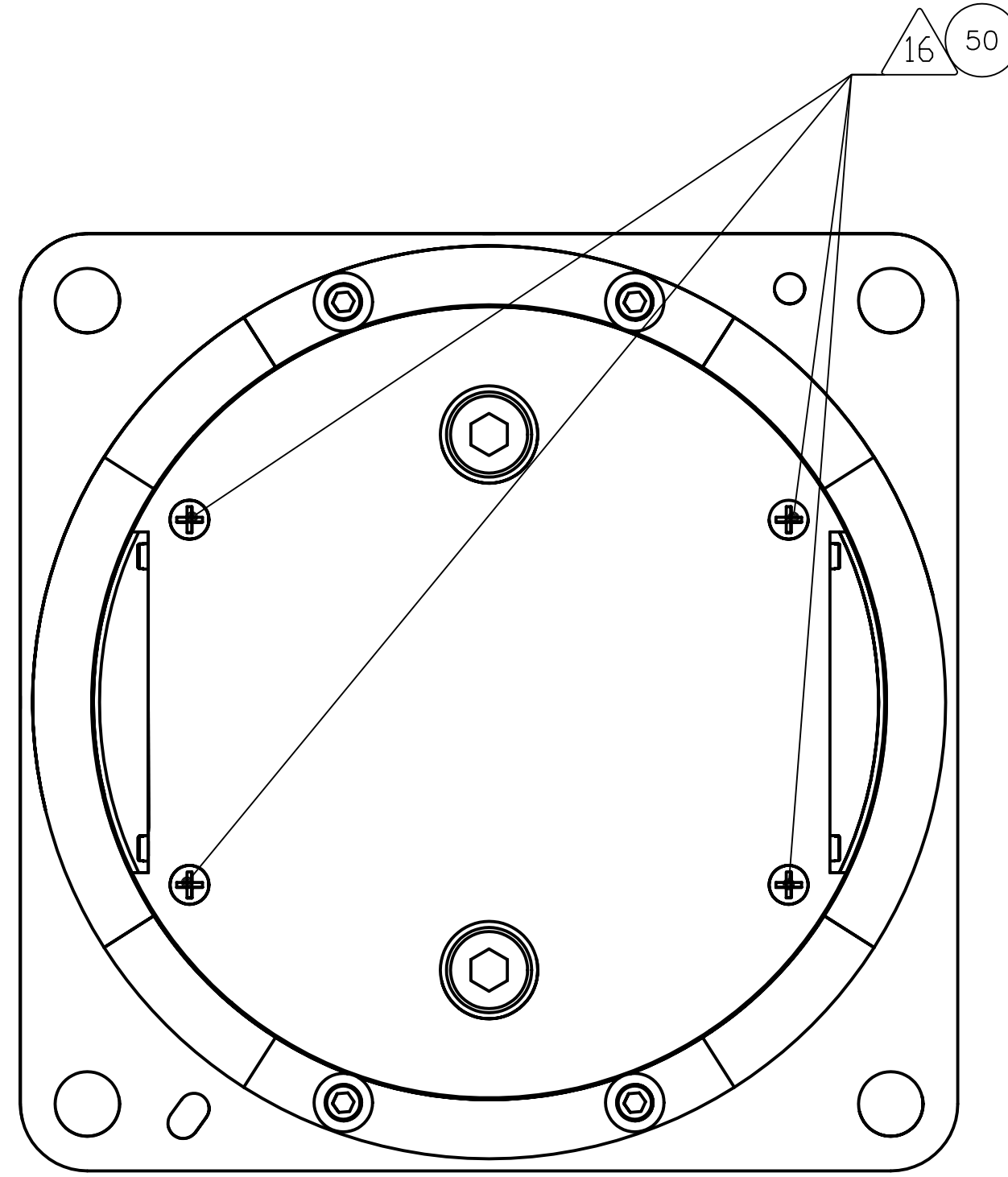

-2 CONFIGURATION SHOWN
 -3 CONFIGURATION IS SIMILAR

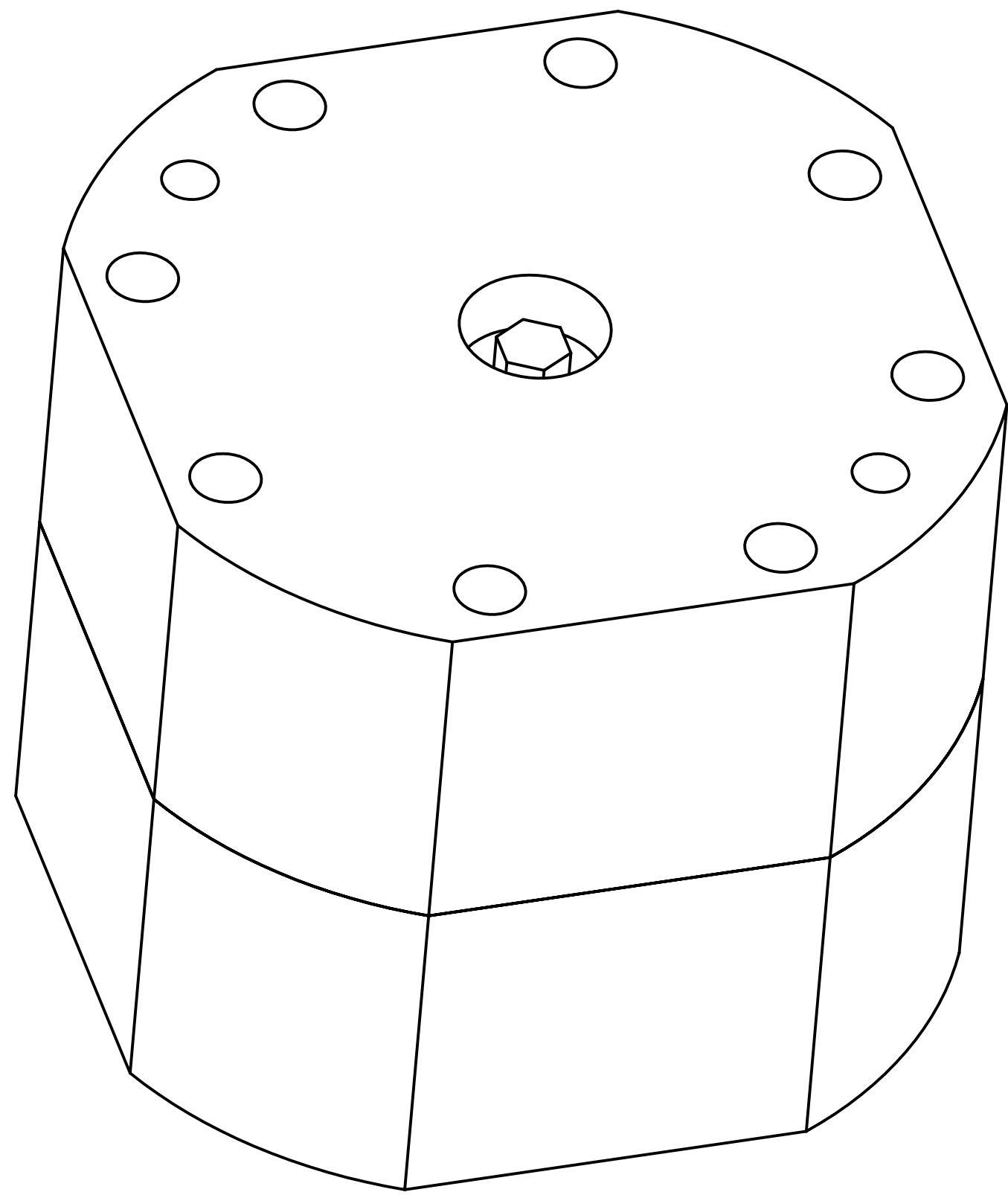

GENERAL VIEW
 REFERENCE ONLY
 SCALE: NONE
 ALL CONFIGURATIONS

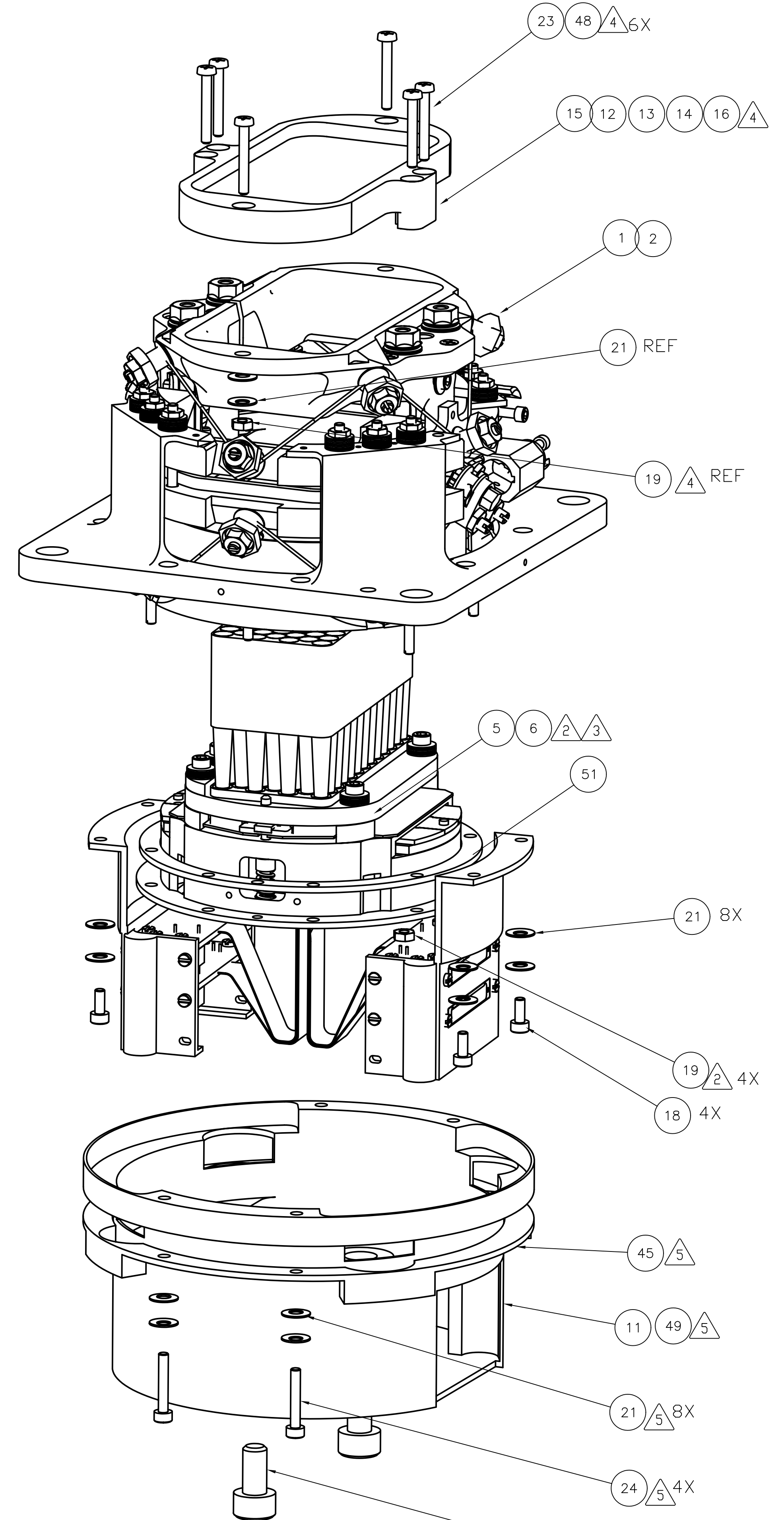

EXPLODED VIEW
 REFERENCE ONLY
 -2 CONFIGURATION SHOWN
 -3 CONFIGURATIONS SIMILAR

SIZE	CAGE NO	10209800	REV
A1	23835		B
SCALE	UNCLASSIFIED	SHEET 4 OF 4	REV 2/00

ECR/NCR List
PFM PMW BDA 10209800-2 S/N 012

NOTE: All of these have been incorporated into released drawings.

1. HR-SP-JPL-ECR-003 – Spectrometer BDA Envelope Height
2. HR-SP-JPL-ECR-005 – 300mK Stage Assembly – BDA Kapton cable routing design error.
3. HR-SP-JPL-NCR-005 – PMW and PSW focal position shift



**DOCUMENT / ENGINEERING
CHANGE REQUEST (ECR)**

**PRODUCT ASSURANCE
Space Science and Technology
Department**

DCR / ECR Number: HR-SP-JPL-ECR-003

Spacecraft / Project	HERSCHEL	Originator's Name	Martin Herman	
System / Experiment / Model	SPIRE /	Signature		
Sub-System		Date	November 20,2003	
Assembly		Classification	Urgent	Routine
Sub-Assembly		Ref. Doc. / Drwg No.	JPL dwg 10209721	
Item	Bolometer Detector Assembly (BDA)	Reference		

ECR/DCR Title	Spectrometer BDA Envelope Height
----------------------	---

ECR Description

On the ICD Drawing 10209721 sheet 2, zone H4, the current maximum height dimension is 42.5 mm from the BDA mounting plate. This dimension needs to be changed to 43.6 to encompass the two spectrometer BDA types, SLW and SSW. Photometer BDA types do not require this change. The current dimension will be replaced with a note giving the two BDA type dependent values. The allowed 300mK stage shift given in note 9 will remain.

Need / Justification For Change

The Spectrometer BDA (types SLW and SSW) 300mK filter stacks were at some point increased in thickness due to the addition of a lens. This change was not flowed down into the BDA ICD. The SLW BDA S/N008 maximum height was measured at 44.04 mm from the mounting plate, which is 1.04 mm higher than the current allowed ICD range. The nominal 42.5 mm height plus the 0.5mm allowed displacement of the 300mK stage (see ICD note 9) gives the current 43.0 mm max height.

Affected Items / Work package (Title, Number, Issue, Para)

ICD drawing 10209721 rev B

Related Factors (Highlight as applicable)

Spacecraft	Performance	Power	Others (Specify)
Ground Segment	Elect. Interfaces	Weight	
Launch Vehicle	Mech. Interfaces	Schedule	
Payload	Test/Verification	Cost	

Attachments	Distribution

Change Approved Project		Change Approved Customer	
Project Closure		Customer Closure	



**DOCUMENT / ENGINEERING
CHANGE REQUEST (ECR)**

**PRODUCT ASSURANCE
Space Science and Technology
Department**

DCR / ECR Number: HR-SP-JPL-ECR-005

Spacecraft / Project	HERSCHEL	Originator's Name	Anthony Turner	
System / Experiment / Model	SPIRE /	Signature		
Sub-System		Date	1/19/2004	
Assembly	10209800 -2 and -3	Classification	Urgent	Routine
Sub-Assembly	10209820 and 10209830	Ref. Doc. / Drwg No.	10209775	
Item	Kapton cables assemblies, 10217706 and 10209825	Reference		

ECR/DCR Title	300mk Stage Assembly-BDA Kapton cable routing design error
---------------	--

ECR Description

Kapton cable right (10217705) was designed for a length of 73.93mm and Kapton cable left (10209824) was designed for a length of 68.87mm. This length designation forces the shorter cable to route into connector positions J01 and J02 on the 10209820 and 10209830 Detector Assembly-BDA builds while the longer cable will route into the J03 and J04 connector positions. This routing will cause a swap in the pixel maps for each connector denoted in wiring schematic 10209725-A under the 10209800-2 and 10209800-3 columns. Below is the correct switch in pixel maps for each column (only the first pixel of the original column is denoted for all connectors but the entire column should be switched accordingly):

10209800-2 P/MW: J01 – first pixel A7, J02 – first pixel E7, J03- first pixel A13, J04 – first pixel R1

10209800-3 P/SW: J01 – first pixel D6, J02 – first pixel F12, J03- first pixel R1, J04 – first pixel E1

Need / Justification For Change

The current flex cable assembly/routing will not correctly map to the pixel locations denoted in 10209725-A wiring schematic, SPIRE. The current schedule/budget will not allow for an acquisition of replacement cables which may have at least a 12-20 week lead from the manufacture. All sub-assembly builds (10209820 and 10209830) would have to be placed on hold until the new cables arrive. The schedule impact could be up to 6 months. The above pixel map designation change would have a minimal effect on the software side, save from rebuilding flex kapton cables and keep the project on its current schedule.

Affected Items / Work package (Title, Number, Issue, Para)

All 10209820 and 10209830 sub assemblies.
Drawing 10209775-A

Related Factors (Highlight as applicable)

Spacecraft	Performance	Power	Others (Specify)
Ground Segment	Elect. Interfaces	Weight	
Launch Vehicle	Mech. Interfaces	Schedule	
Payload	Test/Verification	Cost	

Attachments	Distribution

Change Approved Project		Change Approved Customer	
Project Closure		Customer Closure	

NCR Number: HR-SP-JPL-NCR-005

Spacecraft / Project	Herschel	Originator's Name	Martin Herman	
Experiment / Model	SPIRE / PFM+FS	Signature		
Sub-System		Date	July 1, 2004	
Assembly		Level (Highlight if applicable)	Major	Minor
Sub-Assembly				
Item	PMW and PSW BDA (10209800 -2 and -3)	NRB Reference		
Serial Number	11, 12, 14,15 (TBC)			

NCR Occurred During (Highlight if applicable)	Manufacture	Inspection	Test	Integration	Other
---	--------------------	------------	------	-------------	-------

NCR Title	PMW and PSW focal position shift
------------------	---

NCR Description
<p>An internal mechanical interference problem discovered during the manufacture of the PMW BDA has required a shift of the feedhorn and detector position with respect to the exterior envelope of the BDA. The exterior BDA envelope is unchanged. This NCR applies to PFM and FS models of the PMW and PSW BDAs.</p> <p>This problem causes a non-conformance with the focus position specified in the ICD drawing 10209721 (see sheet 2, zone G3, and values tabulated on sheets 5-7). The PMW nominal focus position is changed by 1.0mm from 33.2mm to 32.2mm. The PSW focus position is changed by 1.2mm from 25mm to 23.8mm.</p> <p>Front-short and back-short distances at the detectors are not affected by this change. The distance from the 300mK filter to the feedhorn entrance plane is increased by the shifts given above.</p> <p>Other effects of this NCR are a small mass increase (approximately 4 grams) and a slight CG shift (estimated z-cg decrease of ~0.5mm). (Note that the PFM PMW, which is the only affected unit yet assembled, has a mass of 605g including the mass increase. This is still less than the 632g ICD limit.)</p>
Cause of NCR
Disposition / Corrective Action
Document or Drawing Affected (Title, Number & Issue)
Estimated COST OF NCR (cost of : correction, Materials, Resource, and delay to Project etc.)



**NON-CONFORMANCE REPORT
(NCR)**

PRODUCT ASSURANCE
Space Science and Technology
Department

NCR Number:

HR-SP-JPL-NCR-005

NCR CLOSED (Signatures Required)	PA Manager (Or Deputy)	Project Manager (Or Deputy)	Date

Waiver List

- 1) HR-SP-JPL-RFW-005 (Sine Vibration Omission)**

- 2) HR-SP-JPL-RFW-006 (Vibration Test Levels)**

- 3) HR-SP-JPL-RFW-008 (Thermal Time Constant Measurement Omission)**

RFW/RFD Number:	HR-SP-JPL-RFW-005
------------------------	--------------------------

Spacecraft / Project	Herschel	Originator's Name	Kalyani Sukhatme	
System / Experiment / Model	SPIRE	Signature / Date		
Sub-System	detectors	Request Type (Highlight applicable request)	Waiver (RFW)	Deviation (RFD)
Assembly		Organisation	Jet Propulsion Laboratory	
Sub-Assembly		Ref. Doc. / Drwg No.	SPIRE-JPL-PRJ-000456	
Item		References		
Serial No.				

RFW/RFD Title	BDA and JFET module sine test deletion
----------------------	---

End Items(s) Affected (Hardware, Software)		
Name	CI-Number	Model(s)
Bolometric Detector Assemblies JFET Modules		CQM, PFM, FS CQM, PFM, FS

Requirement / Interface Documents Affected				
Specification/Drawing Title	Number	Issue	Date	App. Paragraph
BDA-SSSD (SPIRE-JPL-PRJ-000456)		3.2	Jan 7, 2003	BDA-DES-10, JFET-DES-07

Description of Deviation / Discrepancy / Non-Conformance

High Level Sine- Vibe Test is not performed on these units

Other Items or Requirements (Potentially) Affected

Need for RFW/RFD and Rationale for Acceptance

The hardware has to be qualified under a cold vibration test and is installed in the cold vibration facility for the purpose of the test. The high level sine vibration test configuration will put the hardware and the personnel at risk since the cold vibration facility is not structurally capable of withstanding the high levels. Obtaining additional resources (cost and schedule) for developing a new set-up is not feasible at this time.

	Approved	Rejected	Name	Date
JPL Engineering:				
JPL Product Assurance:				
CCB-Chairman:				
Principal Investigator				
Product Assurance:				
Co-Investigator				
Prime Contractor				
ESA Project Office				

RFW/RFD Number:	HR-SP-JPL-RFW-006
------------------------	--------------------------

Spacecraft / Project	Herschel	Originator's Name	
System / Experiment / Model	SPIRE	Signature / Date	
Sub-System	Detector	Request Type (Highlight applicable request)	Waiver (RFW) Deviation (RFD)
Assembly	BDA	Organisation	Jet Propulsion Laboratory
Sub-Assembly		Ref. Doc. / Drwg No.	
Item		References	
Serial No.			

RFW/RFD Title	
----------------------	--

End Items(s) Affected (Hardware, Software)		
Name	CI-Number	Model(s)
BDA		QM, CQM, PFM, FS

Requirement / Interface Documents Affected				
Specification/Drawing Title	Number	Issue	Date	App. Paragraph
BDA-SSSD	BDA-DES-10	3.2	Jan 7, 03	

Description of Deviation / Discrepancy / Non-Conformance

- 1) Random Vibration Test Levels are not the same as given in the BDA-SSSD (Issue 3.2), BDA-Des-10
- 2) There are five different flavours of the BDA. The qualification vibration test is done on only one QM unit which is of the PLW type.

Other Items or Requirements (Potentially) Affected

Need for RFW/RFD and Rationale for Acceptance

1. The random vibration test levels are as specified by Berend Winter (MSSL) in an email on May 2, 2003, which superseded the BDA-SSSD
2. The qualification test program in using the PLW flavor as the only Qual Model, is given in Interoffice Memorandum, Oct. 3, 2003, Henry Abakians, Subject: SPIRE BDA Random Vibration Test Program [IOM 5132-03-167]

	Approved	Rejected	Name	Date
Engineering:				
Product Assurance:				
CCB-Chairman:				
Principle Investigator				
Product Assurance:				
Co-Investigator				
Prime Contractor				



**REQUEST FOR WAIVER / DEVIATION
(RFW/RFD)**

**PRODUCT ASSURANCE
Space Science and Technology
Department**

RFW/RFD Number:

HR-SP-JPL-RFW-006

ESA Project Office				
--------------------	--	--	--	--



**REQUEST FOR WAIVER / DEVIATION
(RFW/RFD)**

**PRODUCT ASSURANCE
Space Science and Technology
Department**

RFW/RFD Number:	HR-SP-JPL-RFW-008
------------------------	--------------------------

Spacecraft / Project	HSO / SPIRE	Originator's Name	Martin Herman	
System / Experiment / Model	SPIRE	Signature / Date	12/10/2004	
Sub-System	THERMAL CONTROL	Request Type (Highlight applicable request)	Waiver (RFW)	Deviation (RFD)
Assembly		Organisation		
Sub-Assembly		Ref. Doc. / Drwg No.	IRD-COOL-R05 BDA-PER-10	
Item	10209800-2	References		
Serial No.	S/N 012			

RFW/RFD Title	Thermal Control acceptance vibration tests - Z axis only.
----------------------	--

End Items(s) Affected (Hardware, Software)		
Name	CI-Number	Model(s)
SPIRE Photometer Medium Wavelength Bolometer Detector assembly		PFM

Requirement / Interface Documents Affected				
Specification/Drawing Title	Number	Issue	Date	App. Paragraph
BDA-HCO-2				

Description of Deviation / Discrepancy / Non-Conformance

BDA thermal time constant was not measured. This was an oversight by the test team.

Other Items or Requirements (Potentially) Affected

Need for RFW/RFD and Rationale for Acceptance

This measurement can be done at the instrument system level. Detector time constant has been measured and this provides confidence (combined with nominal performance for this parameter for 3 previously delivered flight units) that the probability of a problem is low.

	Approved	Rejected	Name	Date
Engineering:				
Product Assurance:				
CCB-Chairman:				
Principle Investigator				
Product Assurance:				
Co-Investigator				
Prime Contractor				
ESA Project Office				



INTEROFFICE MEMORANDUM

5132-03-167

October 3, 2003

Project: Herschel/Planck

TO: Martin Herman
FROM: Henry Abakians *ha*
SUBJECT: SPIRE BDA random vibration test program

This IOM outlines the random vibration test program for Herschel/Planck project's SPIRE element. Due to schedule and cost constraints, our proposed test program does not strictly conform to JPL's standard random vibration program; however, it maintains a medium to low risk posture.

The recommendations will concentrate on the vibration environment since that is the source of highest stresses on the unit. The SPIRE qualification program also includes thermal cycling and accelerated aging, but it will not be addressed in this IOM.

The SPIRE element of the JPL Herschel/Planck project has several Bolometer Detector Assemblies (BDA). These BDAs are identical in their outer housing, and primarily vary in a thermally isolated suspension which contains the bolometer array and the feedhorn (the suspension is held on to the housing via two rows of braided Kevlar strings). There are five flavors to these suspensions: PSW, PMW, PLW, SSW, SLW (P: photometer, S: spectrometer, LW: long wave, MW: medium wave, SW: short wave). The suspensions also vary in their mass and center of gravity (PLW the heaviest, SSW the lightest).

In a traditional JPL Qual/FA test program, a Qual unit for each BDA flavor would be tested (3-axis, 2 min. per axis), and all subsequent flight units would be FA tested (3-axis test, FA levels, 1 min. per axis). In a traditional Protoflight program, all flight units would be protoflight tested (3-axis test, Qual levels, 1 min. per axis).

The SPIRE element has evolved into a Qual/FA/Protoflight test program. We have built and successfully tested a qual unit (CQM, PLW). It was random vibrated at Qual levels and durations (2 minutes) in three axes. This unit successfully passed the random vibration test, and remained within the specifications (performance or otherwise). Our proposed test program for all subsequent BDAs is as follows:

BDA type	test program	random vibrate axis	duration
PSW	PF	x	2 min
PMW	PF	x	2 min
PLW	Qual/PF	3 axis Qual	2min/axis
		PF-x axis only	1 min
SSW	PF	x	2 min
SLW	PF	x	2 min

The test program deviates from a standard JPL program; however, we believe it maintains an acceptable risk posture for the following reasons:

1-The vibration in the z-direction is substantially more benign than x and y. Therefore, we can eliminate the random vibration test in the z-direction for all flight units (this is based on the CQM test results).

2-There is sufficient cross-talk between x and y (based on CQM test results). Therefore, we can eliminate the y direction shake and perform the test in the x-direction for an additional 1 minute (x is the more severe direction; moreover, since we are not concerned with low cycle fatigue failure – substantiated by the CQM test - we feel justified in extending the x-direction test duration to 2 minutes, thus indirectly testing for y-direction).

While it is clearly more desirable to test in y-direction directly, eliminating this test is primarily driven by cost and schedule constraints: all our test are performed at or below 100K, thus a one axis vibration will require a minimum of 3 work days; however, extending a 1 minute test to 2 minutes will not impact schedule, cost, or the safety of the hardware.

3-We have tested the heaviest assembly (PLW) for our qualification program. This ensures that our design is validated for the highest possible stresses in the Kevlar string.

4- Force transducers will be utilized in 3 directions. Their responses will be correlated with the CQM results providing additional assurance on hardware workmanship, reliability and robustness.

Concurrence: John Forgrave
John Forgrave,
Environmental requirements Engineering, Group Supervisor

Concurrence: Paul MacNeal
Paul MacNeal, Dynamics Engineer
Herschel/Planck

Concurrence: Tim Larson for
Tim Larson, Mission Assurance Manager
Herschel/Planck

Distribution:
Bill McAlpine
Margaret Frerking
Michael O'Connell
Gary Parks
Kalyani Sukhatme
Mark Weilert

Open Problem / Failure Report (PFR) List

Open PFR's on This Hardware (PFM PMW BDA 10209800-2 S/N 012):

NONE

Open PFR's on Similar Hardware:

NONE

SPIRE

Bolometer Detector Assembly

Handling Document

Prepared by
Mark Weilert

20 August, 2003
revised 20 Nov. 03

WARNINGS

BDA is Contamination Sensitive: Open Red Shipping container only in a FED-STD-209 Class 10000 clean room (ISO 14644-1 class 7) or better. Handle BDA with gloves only.

BDA is ESD Sensitive, handle with grounding straps, ESD-safe gloves and ESD smocks at an ESD-safe workstation. Note that no connector savers or other connector protection are shipped with the BDA, per the business agreement.

BDA is Fragile: Do not drop or otherwise shock. Take care to avoid applying unnecessary force to the Kevlar suspended portion of the BDA. In particular, do not torque the thermal strap interface fasteners to greater than 320 N*mm. The BDA is preferably held/supported either by its square mounting flange, or by the light-seal can which holds the electrical connectors. Note that the red shipping container provides only minimal shock isolation, and should be treated as equally fragile while the BDA is inside. Because the Kevlar tension is higher at room temperature than cold, **DO NOT SHAKE TEST AT ANY TEMPERATURE ABOVE 100K** (except for low-level survey shakes, 0.25g typical). A full level shake at room temperature risks **catastrophic** failure. Avoid touching Kevlar braid with anything, it is sensitive to abrasion or cutting by seemingly smooth objects.

BDA is Humidity Sensitive: The Kevlar tension increases with moisture absorption. Keep in a dry environment when possible during storage or while not being handled. (While being actively handled, higher humidity is acceptable to maintain ESD safety, 35-50% RH typical.)

BDA is Temperature Sensitive: The Kevlar tension and creep increases at high temperatures, **DO NOT BAKE OUT AT ABOVE 80°C.**

Unpacking Procedure:

The BDA is shipped in a multi-layer container. A custom shipping container (red) inside a case inside case. The case should be opened only in a reasonably clean area in order to protect the red shipping container, which should only be opened in a class 10000 or better clean room at an ESD-safe workstation. The red shipping container has three shock-monitors attached to the top, labeled 10g, 20g and 50g. The monitors have steel balls and springs which are contained between plastic rails if the unit has not seen the marked shock level. If the monitors have experienced their specified shock, some of the balls will be loose in the bottom. Please note the state of the three shock monitors and report the result to JPL. These monitors may need to be removed from the top of the red shipping container before it is opened, since they probably obstruct access to the vent plug. They are attached with a double-stick tape adhesive and may be pulled off by applying force to the white base. (Avoid just pulling on the clear case, as this will likely open up the monitor and spill the contents.) **NOTE: The cases holding the red shipping container must be returned to JPL for use in future shipments.**

Opening the Red Shipping Container:

An exploded view of the container is shown below. The top is the side with the vent plug in the center. Make sure the area around the plug is clean, then remove the plug to equalize the pressure. The 8 closeout screws are next loosened alternately (with a 1/8"

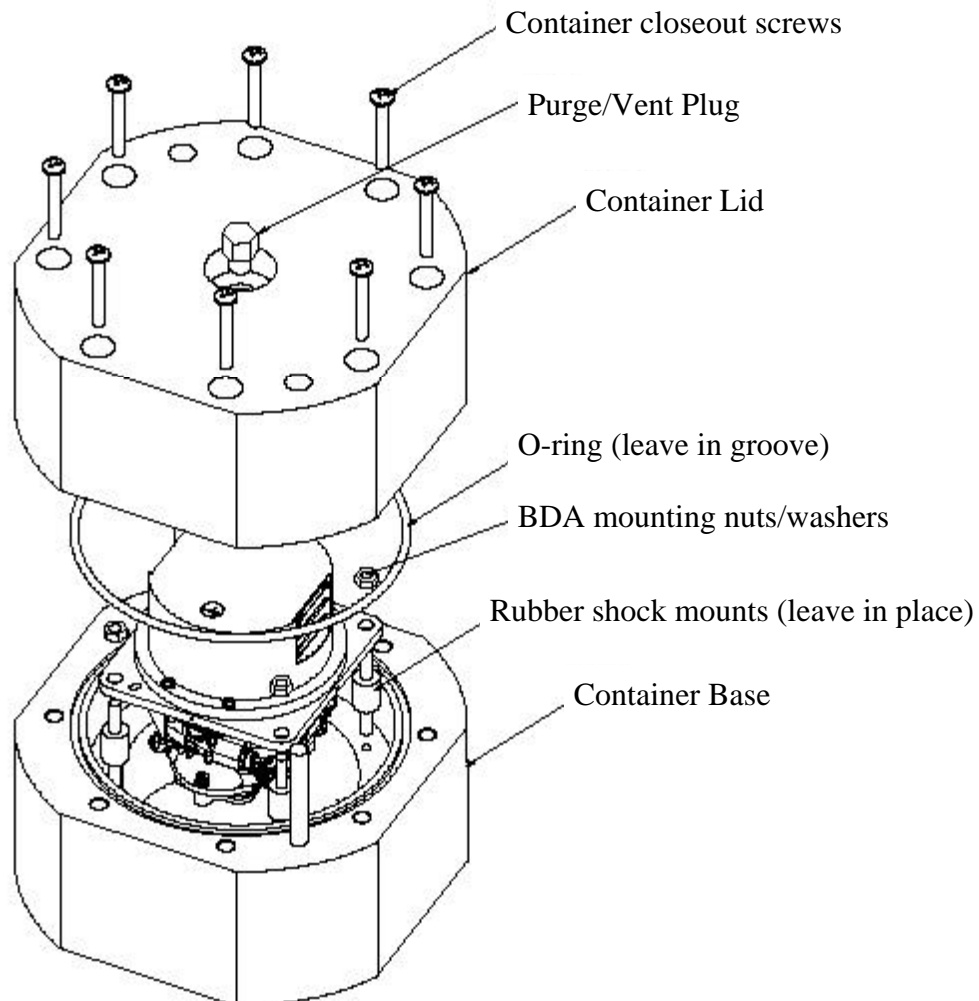

hex key) to relieve pressure on the o-ring seal, and then backed off completely to disengage the screws from the base. The container lid is then lifted straight up to open the container. Two guide pins prevent significant sideways motion of the lid until it is high enough to clear the BDA. The BDA is removed from the shipping container base by removing the mounting nuts and washers from the rubber shock mounts and lifting the BDA straight up.

For re-installation of the BDA into the red container, note that the light can must be up, as shown, to prevent the container lid from hitting the BDA. Also, the epoxy terminations of the Kevlar braids should be oriented towards the cutouts in the container base.

SPIRE

Subject: BDA Electronic Handling Procedure, SPIRE P/MW-PFM S/N012

Prepared by: Anthony Turner

Document No:

Issue: Draft

Date: 12/13/2004

Checked by:

Date:.....

Approved by:.....

Date:.....

Electronic Handling Procedure P/MW-PFM S/N012

Ref:

Issue:

Date:

Distribution

Electronic Handling Procedure P/MW-PFM S/N012

Ref:
Issue:
Date:

Change Record

Issue

Date

Table of Contents

1.	Introduction.....	page	6
2.	Handling.....	page	6
3.	Signal Requirements.....	page	6
4.	Device Isolation.....	page	7
5.	Room Temperature Detector Values Check.....	page	7
6.	Load Resistor-Detector Continuity Check.....	page	12

Glossary

1. Introduction:

This document provides the Electronic Handling Procedure for the Proto-Flight Model-Photometer Medium Wavelength Bolometer Detector Array serial number 012.

2. Handling:

1. **BDA is Contamination Sensitive:** Handle BDA with Gloves only in a FED-STD-209 Class 10000 clean room (ISO 14644-1 class 7) or better.
2. **BDA is ESD Sensitive:** Electronic parts included in the P/MW-PFM S/N012 science instrument are subject to electro-static discharge failures. Please handle with appropriate ESD hardware handling procedures. Handle with grounding straps, ESD-safe gloves, ESD smocks at an ESD-safer workstation.

3. Signal Requirements:

The interface circuit for the BDA contains a series of resistive networks as depicted in figure 1. Two high resistive load resistors ($\sim 6\text{-}14\text{ M}\Omega$) are coupled to a NTD Ge thermistor (R_{bolo}) through a lithographed metalization circuit and provide the bias circuitry for the device. The maximum DC input voltage for the bias lines $V+$ and $V-$ lines is $\pm 1\text{ V}$, and the maximum AC input voltage is 100mV rms .

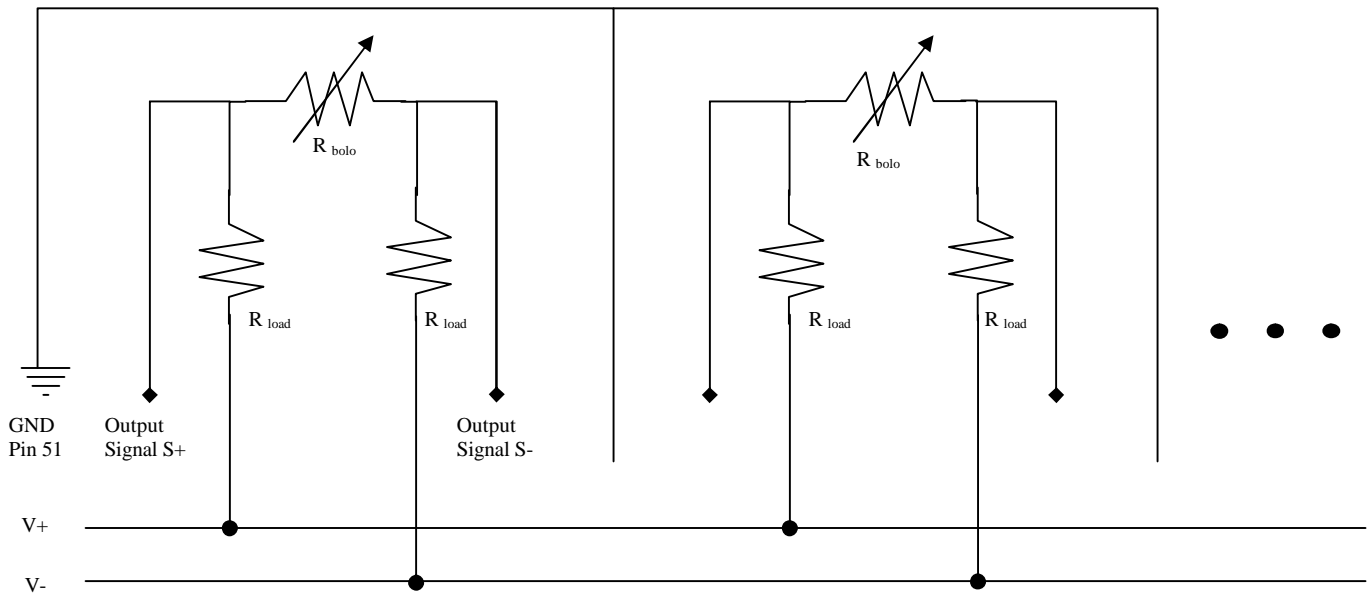

Figure 1: Interface circuit of the Bolometer Detector Array

DC Voltage-Current Limits for Room Temperature Detector Values Check:

Signal	Pin	Nominal Value	Max Value
V+	25	+50mV	+1 V
V-	50	-50mV	-1 V
I+,I-	25,50	10 μ A	25 μ A

DC Voltage-Current Limits for room temperature Load Resistor-Detector Continuity Check:

Signal	Pin	Nominal Value	Max Value
V+	25	+50mV	+1 V
V-	50	-50mV	-1 V
I+, I-	25,50	<0.5 μ A	1 μ A

4. Device Isolation Check:

The 300mK stage Kevlar suspended portion of the detector chassis is grounded directly to the electronic ground on pin 51 of the nanonics 51 pin connectors on each side. A resistance of less than 200 Ω can be checked from the thermal strap of the 300mK stage to electrical ground pin 51. The 2K stage is electrically isolated from the electronic ground via the Kevlar supports. Measuring from pin 51 to any metal section of the 2K stage will yield an open circuit.

5. Room Temperature Detector Values Check

The final measured DC resistance value for each of the bolometer detector at room temperature is shown in tables 1 through 4. The measurements bypass the load resistors in the circuit measuring directly through the output signal pins on the two nanonics 51 pin connectors. All measurements were performed with a Fluke 87 True RMS Multimeter set in the 4k Ω range. All measurements are in k Ω unless designated otherwise. Channels that are out of range are re-measured using the 40M Ω range to determine their value. The failure mode of any particular channel is also designated in tables 1 through 4. The designation for the failure modes are open- Channel open at 300mK, short-channel shorted at 300mK, and float- channel floating at 300mK.

Table 1: P/MW PFM S/N012 Room Temperature DC Detector Measurements J01 connector

Connector Label	Signal	Nanonics Pin From	Nanonics Pin To	Detector Label	Resistance (kohms)	Failure Mode
J01	1	1	26	A7	3.058	
	2	2	27	A6	3.07	
	3	3	28	B6	3.12	
	4	4	29	C7	3.175	
	5	5	30	A5	3.113	
	6	6	31	B5	3.183	
	7	7	32	C6	3.22	
	8	8	33	D6	3.242	
	9	9	34	B4	3.221	
	10	10	35	C5	3.257	
	11	11	36	D4	3.25	
	12	12	37	A4	3.262	
	13	13	38	C4	3.334	
	14	14	39	B3	3..318	
	15	15	40	C3	3.373	
	16	16	41	B2	3.407	
	17	17	42	D2	3.493	
	18	18	43	A3	3.45	
	19	19	44	A2	3.498	
	20	20	45	C2	3.575	
	21	21	46	B1	3.577	
	22	22	47	A1	3.55	
	23	23	48	DK1	3.635	
	24	24	49	C1	3.679	
	V+ to V-	25	50		0.356M	
	V- to gnd	50	51		>30M	
	V+ to gnd	25	51		>30M	
	Chassis to gnd				87.0 ohms	

Table 2: P/MW PFM S/N012 Room Temperature DC Detector Measurements J02 connector

Connector Label	Signal	Nanonics Pin From	Nanonics Pin To	Detector Label	Resistance (kohms)	Failure Mode
J02	1	1	26	E7	3.105	
	2	2	27	D7	3.171	
	3	3	28	F7	3.128	
	4	4	29	E8	3.165	
	5	5	30	G8	3.14	
	6	6	31	F8	3.176	
	7	7	32	E9	3.231	
	8	8	33	G9	3.161	
	9	9	34	D9	3.301	
	10	10	35	F9	3.277	
	11	11	36	E10	3.31	
	12	12	37	G10	3.224	
	13	13	38	F10	3.31	
	14	14	39	E11	3.352	
	15	15	40	G11	3.305	
	16	16	41	F11	3.375	
	17	17	42	E12	3.465	
	18	18	43	G12	3.413	
	19	19	44	F12	3.564	
	20	20	45	G13	3.507	
	21	21	46	DK2	3.621	
	22	22	47	SH	2.047	
	23	23	48	SH	2.089	
	24	24	49	R2	4.32M	
	V+ to V-	25	50		.370M	
	V- to gnd	50	51		>30M	
	V+ to gnd	25	51		>30M	
	Chassis to gnd				93.7 ohms	

Electronic Handling Procedure P/MW-PFM S/N012

Ref:

Issue:

Date:

Table 3: P/MW PFM S/N012 Room Temperature DC Detector Measurements J03 connector

Connector Label	Signal	Nanonics Pin From	Nanonics Pin To	Detector Label	Resistance (kohms)	Failure Mode
J03	1	1	26	A13	3.456	
	2	2	27	T1	3.548	
	3	3	28	B12	3.466	
	4	4	29	C13	3.454	
	5	5	30	A12	3.372	
	6	6	31	D12	3.43	
	7	7	32	C12	3.374	
	8	8	33	B11	3.318	
	9	9	34	A11	3.216	
	10	10	35	E13	3.284	
	11	11	36	D11	3.247	
	12	12	37	C11	3.188	
	13	13	38	B10	3.132	
	14	14	39	A10	3.107	
	15	15	40	D10	3.182	
	16	16	41	B9	3.115	
	17	17	42	C10	3.131	
	18	18	43	C9	3.1	
	19	19	44	A9	3.035	
	20	20	45	B8	3.063	
	21	21	46	A8	3.069	
	22	22	47	D8	3.115	
	23	23	48	C8	3.078	
	24	24	49	B7	3.038	
	V+ to V-	25	50		0.356M	
	V- to gnd	50	51		>30M	
	V+ to gnd	25	51		>30M	
	Chassis to gnd				91.1 ohms	

Table 4: P/MW PFM S/N012 Room Temperature DC Detector Measurements J04 connector

Connector Label	Signal	Nanonics Pin From	Nanonics Pin To	Detector Label	Resistance (kohms)	Failure Mode
J04	1	1	26	R1	4.20M	
	2	2	27	G1	3.394	
	3	3	28	T2	3.493	
	4	4	29	E1	3.392	
	5	5	30	D1	3.405	
	6	6	31	F1	3.308	
	7	7	32	E2	3.342	
	8	8	33	G2	3.243	
	9	9	34	F2	3.213	
	10	10	35	G3	3.159	
	11	11	36	E3	3.201	
	12	12	37	D3	3.235	
	13	13	38	F3	3.125	
	14	14	39	G4	3.047	
	15	15	40	E4	3.138	
	16	16	41	F4	3.071	
	17	17	42	E5	3.113	
	18	18	43	D5	3.127	
	19	19	44	F5	3.047	
	20	20	45	G5	2.988	
	21	21	46	E6	3.06	
	22	22	47	G6	3.005	
	23	23	48	F6	3.013	
	24	24	49	G7	2.995	
	V+ to V-	25	50		0.370M	
	V- to gnd	50	51		>30M	
	V+ to gnd	25	51		>30M	
	Chassis to gnd				93.1 ohms	

6. Load Resistor-Detector Continuity Check

A DC continuity check of the load resistors in series with the bolometer detectors will complete the electrical checkout at room temperature. The test can be performed with a Fluke 87 True RMS multimeter set on the $40\text{M}\Omega$ scale. The data set measures from V+ to output signal S+ and V- to output signal S- for each channel. The nominal value read for the live bolometer channels (room temp detector DC resistance $\sim 1.5\text{k}\Omega$) should read approximately $3\text{-}6\text{M}\Omega$. Channels with open bolometer channels will give values $8\text{M}\Omega$ or higher. The Data sets for the P/MW -PFM S/N012 for the final test through the entire circuit are shown in tables 5 through 8.

Table 5: P/MW-PFM S/N012 Load Resistor- Detector DC Continuity Check J01 connector

Connector Label	Signal	Detector Label	Bias V+ (pin 25) To S+ pin	V+ to S+ Resistance (Mohms)	Bias V- (pin 50) To S- pin	V- to S- Resistance (Mohms)
J01	1	A7	1	4.28	26	4.31
	2	A6	2	4.32	27	4.28
	3	B6	3	4.28	28	4.28
	4	C7	4	4.32	29	4.33
	5	A5	5	4.33	30	4.32
	6	B5	6	4.31	31	4.31
	7	C6	7	4.32	32	4.32
	8	D6	8	4.32	33	4.32
	9	B4	9	4.32	34	4.32
	10	C5	10	4.33	35	4.36
	11	D4	11	4.36	36	4.36
	12	A4	12	4.34	37	4.35
	13	C4	13	4.4	38	4.4
	14	B3	14	4.42	39	4.4
	15	C3	15	4.36	40	4.38
	16	B2	16	4.43	41	4.4
	17	D2	17	4.4	42	4.4
	18	A3	18	4.36	43	4.4
	19	A2	19	4.4	44	4.44
	20	C2	20	4.42	45	4.42
	21	B1	21	4.37	46	4.4
	22	A1	22	4.44	47	4.41
	23	DK1	23	4.4	48	4.44
	24	C1	24	4.4	49	4.4

Electronic Handling Procedure P/MW-PFM S/N012

Ref:

Issue:

Date:

Table 6: P/MW-PFM S/N012 Load Resistor- Detector DC Continuity Check J02 connector

Connector Label	Signal	Detector Label	Bias V+ (pin 25) To S+ pin	V+ to S+ Resistance (Mohms)	Bias V- (pin 50) To S- pin	V- to S- Resistance (Mohms)
J02	1	E7	1	4.48	26	4.48
	2	D7	2	4.47	27	4.48
	3	F7	3	4.45	28	4.44
	4	E8	4	4.46	29	4.49
	5	G8	5	4.48	30	4.48
	6	F8	6	4.45	31	4.47
	7	E9	7	4.48	32	4.52
	8	G9	8	4.52	33	4.52
	9	D9	9	4.52	34	4.52
	10	F9	10	4.52	35	4.53
	11	E10	11	4.59	36	4.56
	12	G10	12	4.53	37	4.53
	13	F10	13	4.55	38	4.56
	14	E11	14	4.6	39	4.56
	15	G11	15	4.56	40	4.56
	16	F11	16	4.56	41	4.6
	17	E12	17	4.6	42	4.6
	18	G12	18	4.56	43	4.6
	19	F12	19	4.61	44	4.6
	20	G13	20	4.6	45	4.6
	21	DK2	21	4.6	46	4.6
	22	SH	22	4.6	47	4.62
	23	SH	23	4.6	48	4.6
	24	R2	24	5.64	49	5.66

Table 7: P/MW-PFM S/N012 Load Resistor- Detector DC Continuity Check J03 connector

Connector Label	Signal	Detector Label	Bias V+ (pin 25) To S+ pin	V+ to S+ Resistance (Mohms)	Bias V- (pin 50) To S- pin	V- to S- Resistance (Mohms)
J03	1	A13	1	4.36	26	4.37
	2	T1	2	4.36	27	4.36
	3	B12	3	4.32	28	4.38
	4	C13	4	4.38	29	4.36
	5	A12	5	4.36	30	4.36
	6	D12	6	4.36	31	4.38
	7	C12	7	4.38	32	4.38
	8	B11	8	4.36	33	4.36
	9	A11	9	4.4	34	4.36
	10	E13	10	4.39	35	4.38
	11	D11	11	4.4	36	4.4
	12	C11	12	4.39	37	4.36
	13	B10	13	4.36	38	4.37
	14	A10	14	4.36	39	4.36
	15	D10	15	4.32	40	4.32
	16	B9	16	4.36	41	4.36
	17	C10	17	4.36	42	4.33
	18	C9	18	4.32	43	4.32
	19	A9	19	4.33	44	4.32
	20	B8	20	4.35	45	4.31
	21	A8	21	4.31	46	4.32
	22	D8	22	4.32	47	4.32
	23	C8	23	4.32	48	4.31
	24	B7	24	4.28	49	4.28

Table 8: P/MW-PFM S/N012 Load Resistor- Detector DC Continuity Check J04 connector

Connector Label	Signal	Detector Label	Bias V+ (pin 25) To S+ pin	V+ to S+ Resistance (Mohms)	Bias V- (pin 50) To S- pin	V- to S- Resistance (Mohms)
J04	1	R1	1	5.44	26	5.48
	2	G1	2	4.44	27	4.44
	3	T2	3	4.46	28	4.42
	4	E1	4	4.41	29	4.45
	5	D1	5	4.44	30	4.44
	6	F1	6	4.46	31	4.43
	7	E2	7	4.4	32	4.44
	8	G2	8	4.42	33	4.44
	9	F2	9	4.46	34	4.44
	10	G3	10	4.4	35	4.44
	11	E3	11	4.42	36	4.44
	12	D3	12	4.44	37	4.44
	13	F3	13	4.43	38	4.45
	14	G4	14	4.44	39	4.44
	15	E4	15	4.4	40	4.4
	16	F4	16	4.44	41	4.44
	17	E5	17	4.44	42	4.44
	18	D5	18	4.4	43	4.4
	19	F5	19	4.44	44	4.43
	20	G5	20	4.4	45	4.4
	21	E6	21	4.38	46	4.4
	22	G6	22	4.4	47	4.4
	23	F6	23	4.4	48	4.39
	24	G7	24	4.36	49	4.4

EIDP Coverage For PMW BDA (SN012)

Unit Identification							
Name		PMW BDA					
Part #		10209800-2					
S/N		#012					

Environmental Testing							
	Axes Tested	Temperature	Duration or Number of Cycles	Pass/Fail	Requirement	Source	Waiver #
Random Vibration Test	X	100 K	2 min per axis	P	X, Y, Z at 90 K 1 min per axis	SSSD Sec # 3.4	HR-SP-JPL- RFW-006
High Level Sine Vibe Test	None	NA	NA	NA	X, Y, Z at 90 K	SSSD Sec # 3.4	HR-SP-JPL- RFW-005
Bakeout	NA	NA	NA	NA	None (other than as part of the assembly procedure)	D-20549	
Thermal Cycles	NA	RoomT to ~ 6 K	2	P	1 thermal cycle roomT to 77 K (max 5)	D-20549	

Other Testing		Frequency [Hz]					
	Pre-full level	Post-full level			Minimum Performance	Source	Waiver #
Lowest Resonant Frequency	303 Hz	299 Hz			> 200 Hz (Goal: >250 Hz)	SSSD Sec # 3.1.3	NA
Metrology Measurements were performed before and after the Vibration Test and the Thermal Cycles							
	Motion in X/Y	Motion in Z		Meets Goal ?	Performance Goal	Source	Waiver #
Maximum motion due to Random Vibration Test	29 μm	27 μm		Y	125 μm in X/Y and 500 μm in Z	SSSD Sec # 3.1.1	NA
Maximum motion due to the 1st thermal cycle	9.6 μm	11 μm		Y	125 μm in X/Y and 500 μm in Z	SSSD Sec # 3.1.1	NA
Maximum motion due to the 2nd thermal cycle	5.1 μm	4.7 μm		Y	125 μm in X/Y and 500 μm in Z	SSSD Sec # 3.1.1	NA
Cumulative Maximum motion	38.7 μm	68.7 μm		Y	125 μm in X/Y and 500 μm in Z	SSSD Sec # 3.1.1	NA
Cold Continuity Measurements were made during each of the thermal cycles							
				Pass/Fail	Requirement	Source	Waiver #
Cold Continuity Test (1st Thermal Cycle)				P	None	NA	NA
Cold Continuity Test (2nd Thermal Cycle)				P	None	NA	NA

Sine

101531, Run 4, X axis

Spire BDA

P/N 10209800-2, S/N : 012

Force Sum X

Before Shake, Cold

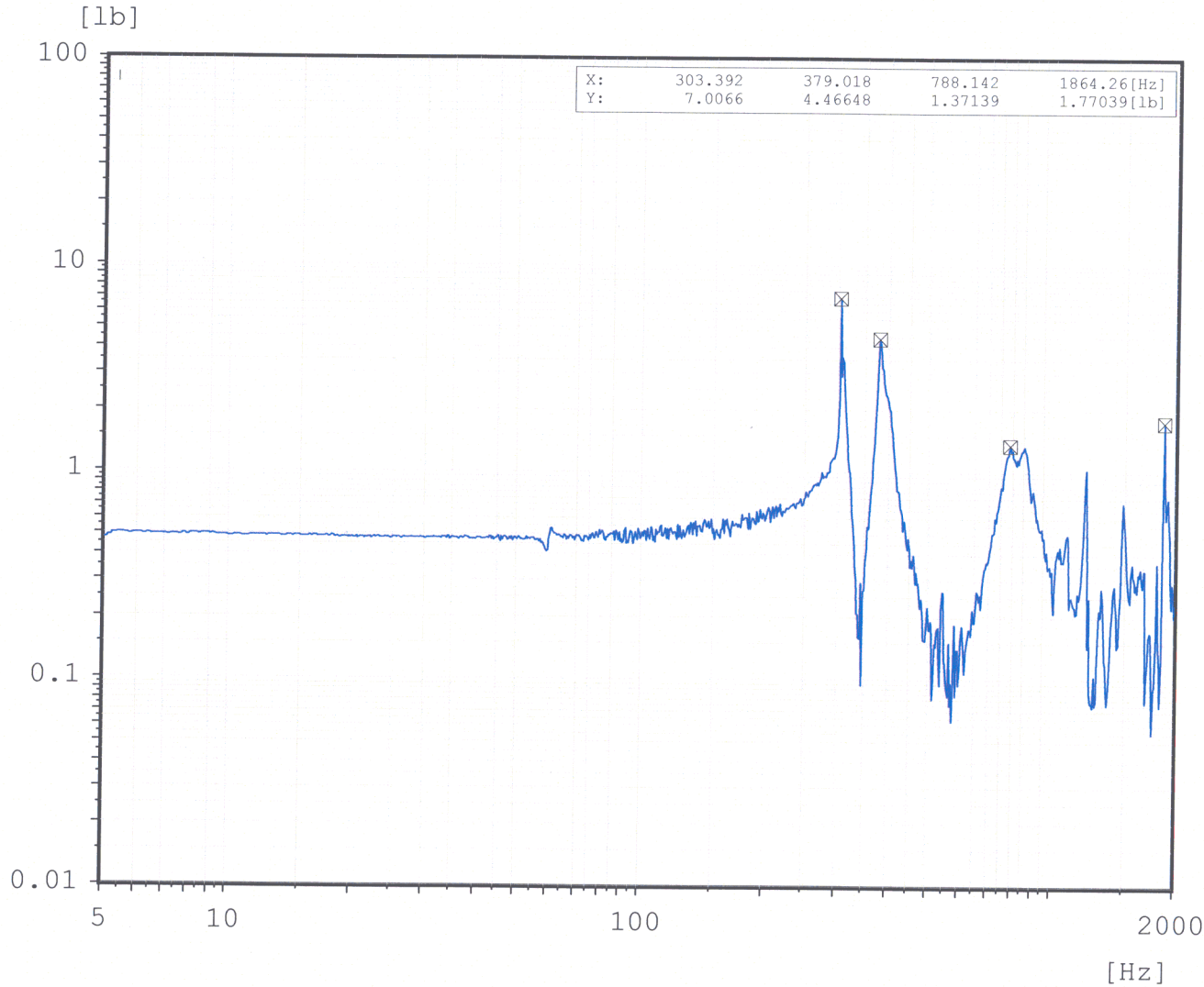

Chan.no: 6
Chan.type: W RMS
Sweep type: logarithmic
Sweeps done: 1
Sweeps req.: 1
Sweep direct.: up
Sweep rate: 4.00 Oct/min
Contr.strat.: Maximum
Unit: lb
Contr.strat.: Closed loop

-- Testing time --
elapsed: 000:02:09
remaining: 000:00:00

Date: 09-09-04
Time: 12:06:38

964#1/Amp #1/ M+P #2

Sine

101531, Run 4, X axis

Spire BDA

P/N 10209800-2, S/N : 012

Force Sum Y

Before Shake, Cold

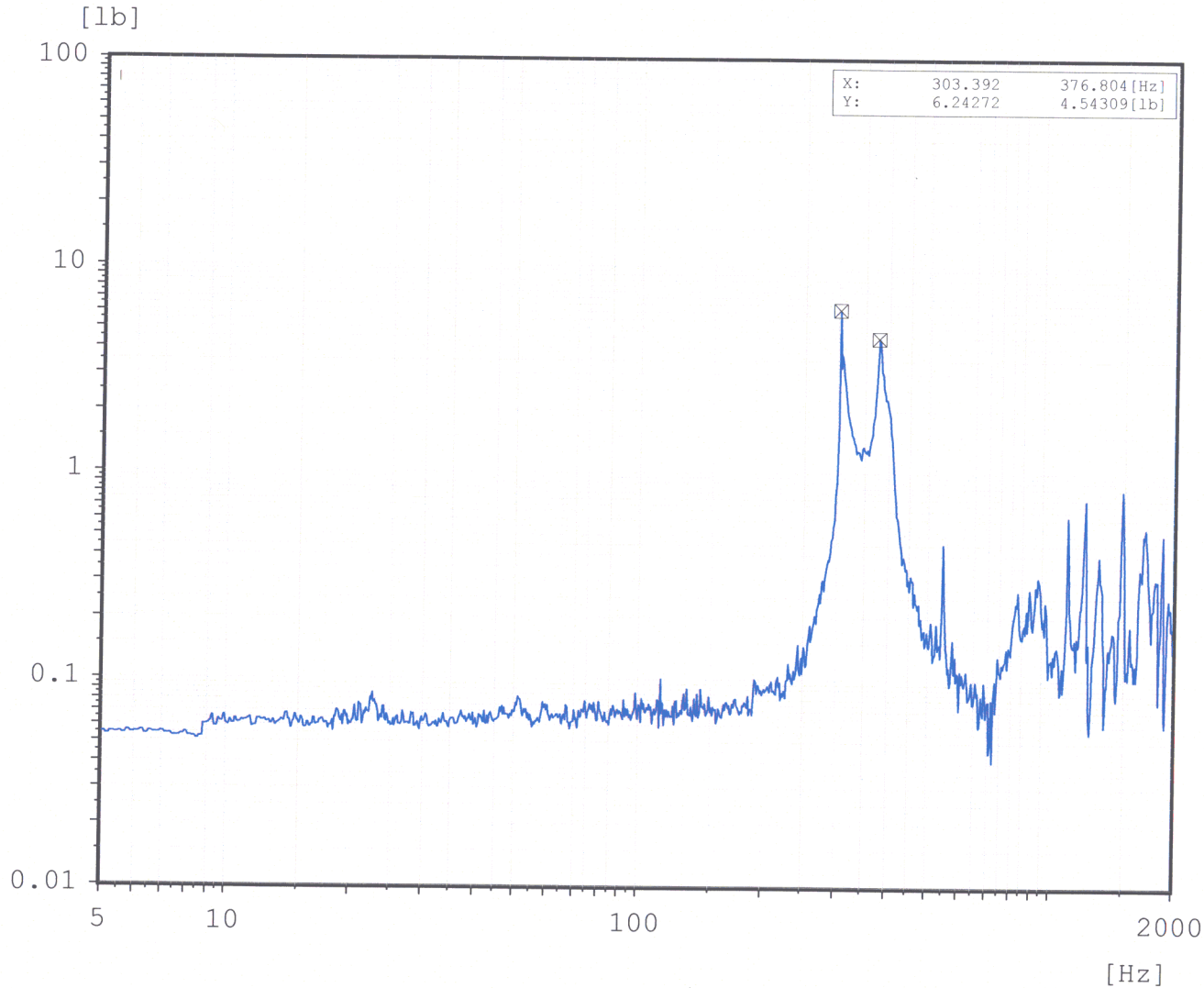

Chan.no: 7
Chan.type: W RMS
Sweep type: logarithmic
Sweeps done: 1
Sweeps req.: 1
Sweep direct.: up
Sweep rate: 4.00 Oct/min
Contr.strat.: Maximum
Unit: lb
Contr.strat.: Closed loop

-- Testing time --
elapsed: 000:02:09
remaining: 000:00:00

Date: 09-09-04
Time: 12:06:38

964#1/Amp #1/ M+P #2

Random

101531, Run 6, X axis

SPIRE BDA

P/N 10209800-2, S/N : 012

[g²/Hz]

Control channel

0dB, Cold

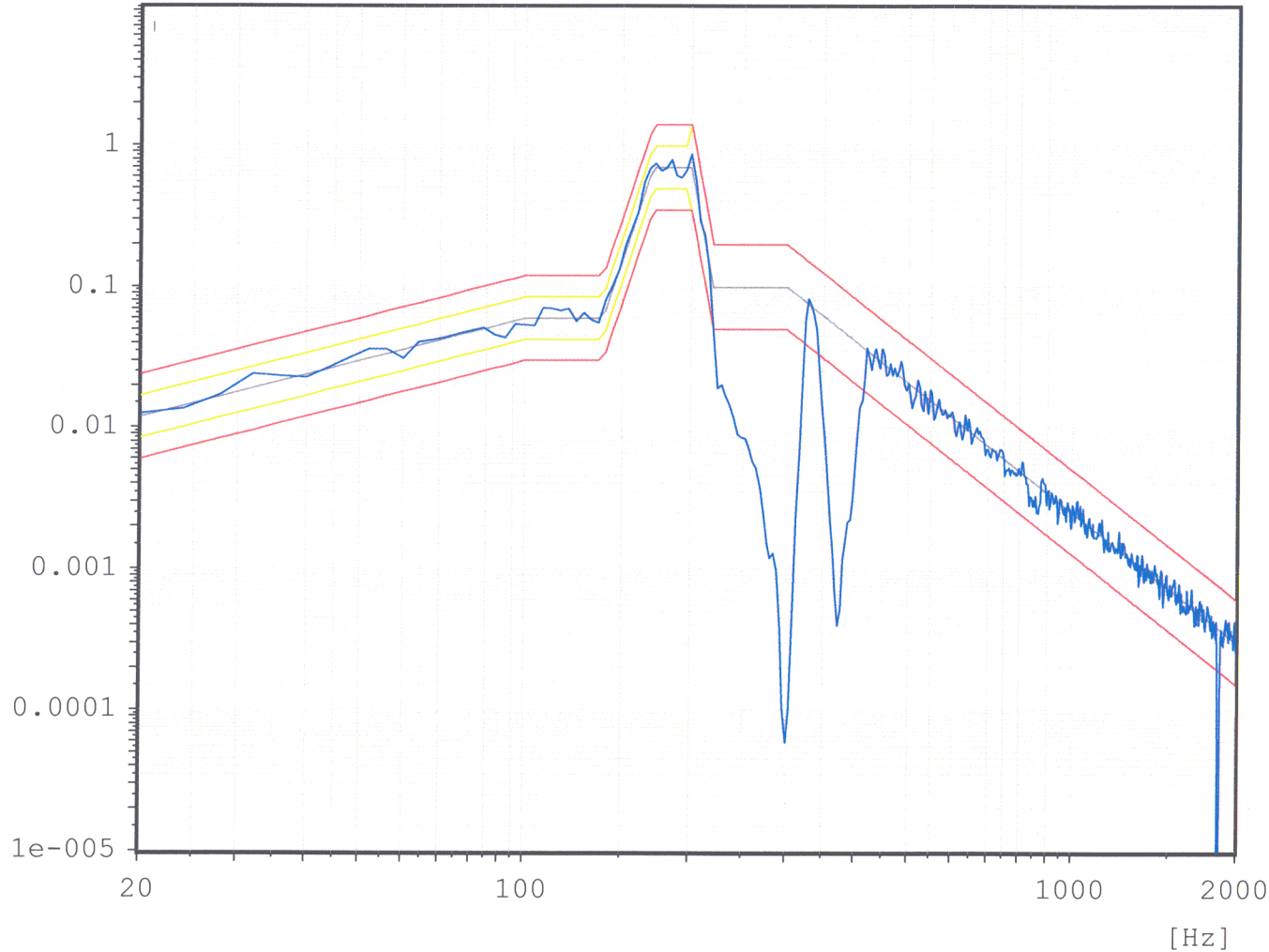

Chan.type: X
DOF: 180
Level: 0.0 dB
Resolution: 4 Hz
Contr.strat.: Maximum
Unit: g²/Hz
RMS (act.): 7.203 g
RMS (req.): 7.945 g
Contr.strat.: Closed loop

-- Time on act. level --
elapsed: 000:02:00
remaining: 000:00:00

-- Time total --
elapsed: 000:03:34
remaining: 000:00:00

Date: 09-09-04
Time: 12:25:57

964#1/ Amp#1/ M+P#2

Random

101531, Run 6, X axis

SPIRE BDA

P/N 10209800-2, S/N : 012

Force Sum X

0dB, Cold



[lb²/Hz]

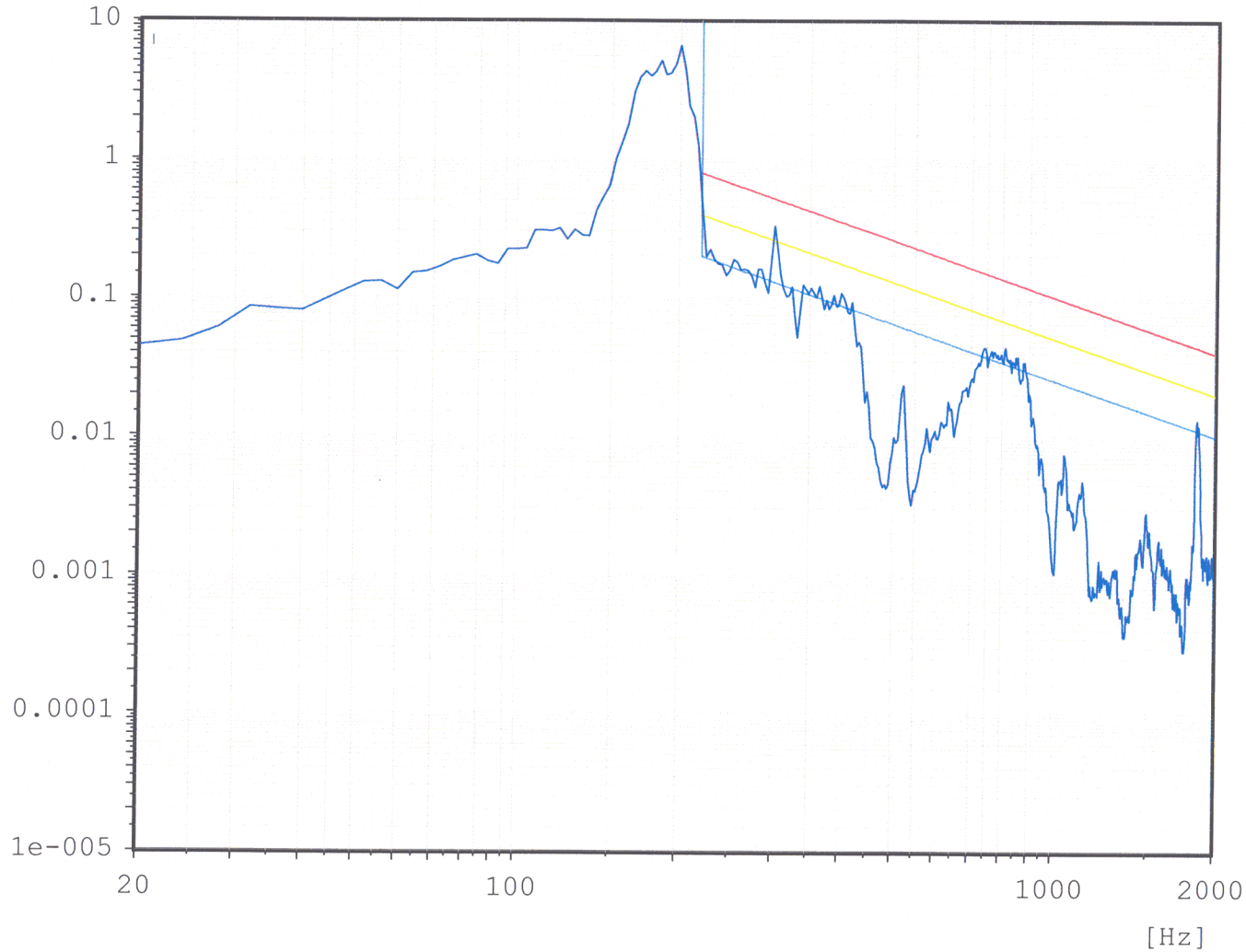

Chan.no: 6
Chan.type: W
DOF: 90
Level: 0.0 dB
Resolution: 4 Hz
Contr.strat.: Maximum
Unit: lb²/Hz
RMS (act.): 17.48 lb
Contr.strat.: Closed loop

-- Time on act. level --
elapsed: 000:02:00
remaining: 000:00:00

-- Time total --
elapsed: 000:03:34
remaining: 000:00:00

Date: 09-09-04
Time: 12:25:57

964#1/ Amp#1/ M+P#2

Random

101531, Run 6, X axis

SPIRE BDA

P/N 10209800-2, S/N : 012

Force Sum Y

0dB, Cold



[lb²/Hz]

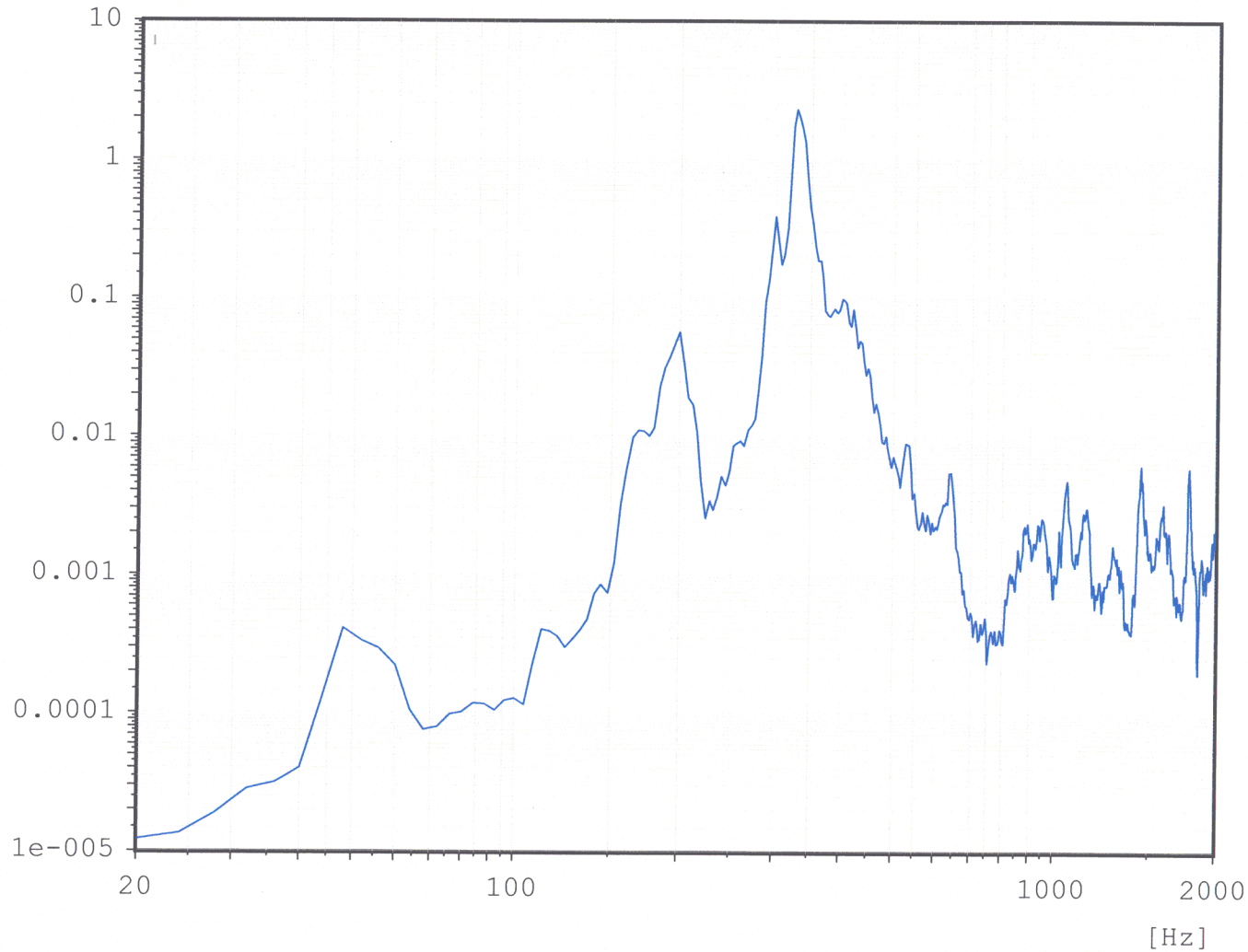

Chan.no: 7
Chan.type: W
DOF: 90
Level: 0.0 dB
Resolution: 4 Hz
Contr.strat.: Maximum
Unit: lb²/Hz
RMS (act.): 8.177 lb
Contr.strat.: Closed loop

-- Time on act. level --
elapsed: 000:02:00
remaining: 000:00:00

-- Time total --
elapsed: 000:03:34
remaining: 000:00:00

Date: 09-09-04
Time: 12:25:57

964#1/ Amp#1/ M+P#2

Sine

101531, Run 8, X axis

Spire BDA

P/N 10209800-2, S/N : 012

Force Sum X

After Shake, Cold

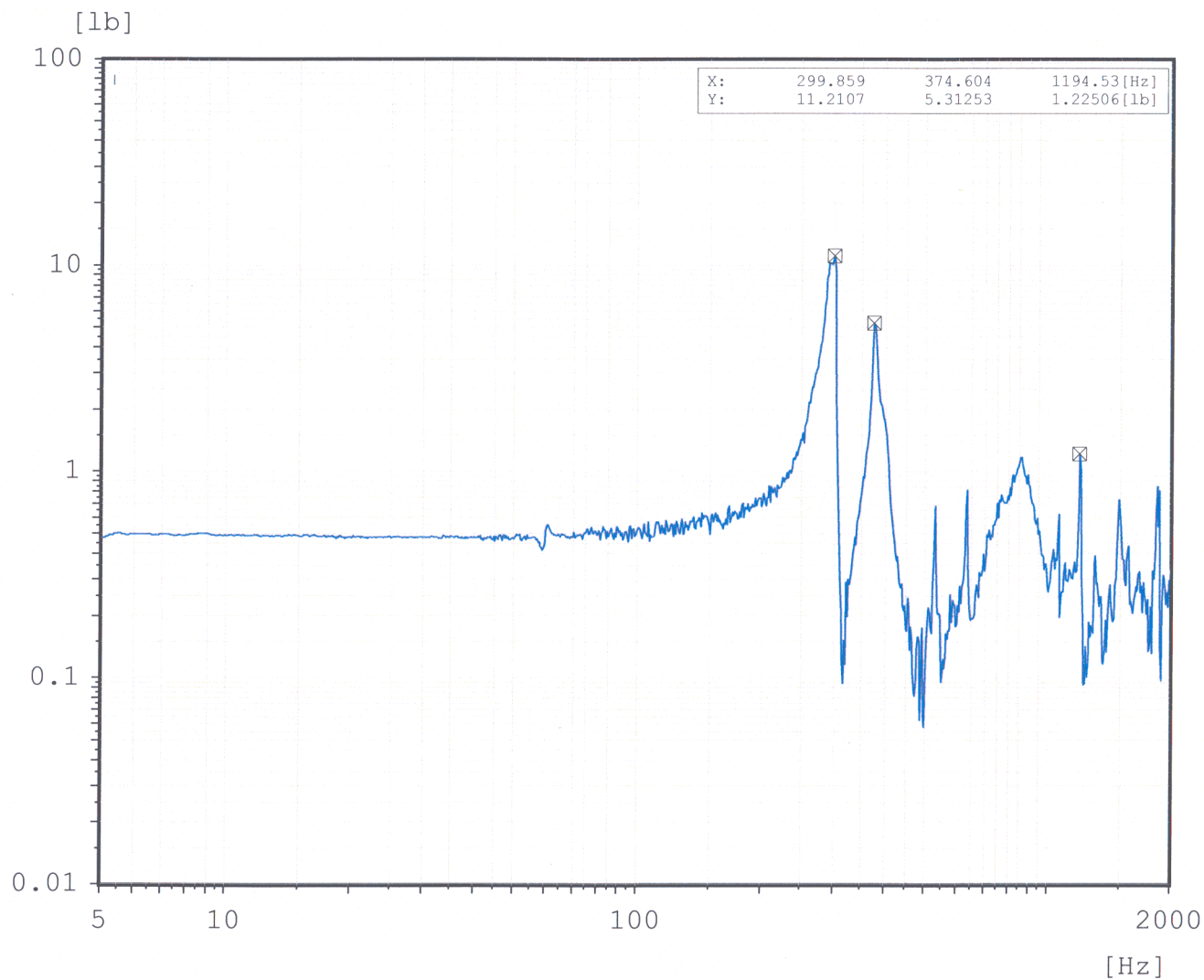

Chan.no: 6
Chan.type: W RMS
Sweep type: logarithmic
Sweeps done: 1
Sweeps req.: 1
Sweep direct.: up
Sweep rate: 4.00 Oct/min
Contr.strat.: Maximum
Unit: lb
Contr.strat.: Closed loop

-- Testing time --
elapsed: 000:02:09
remaining: 000:00:00

Date: 09-09-04
Time: 12:41:56

964#1/Amp #1/ M+P #2

Sine

101531, Run 8, X axis

Spire BDA

P/N 10209800-2, S/N : 012

Force Sum Y

After Shake, Cold

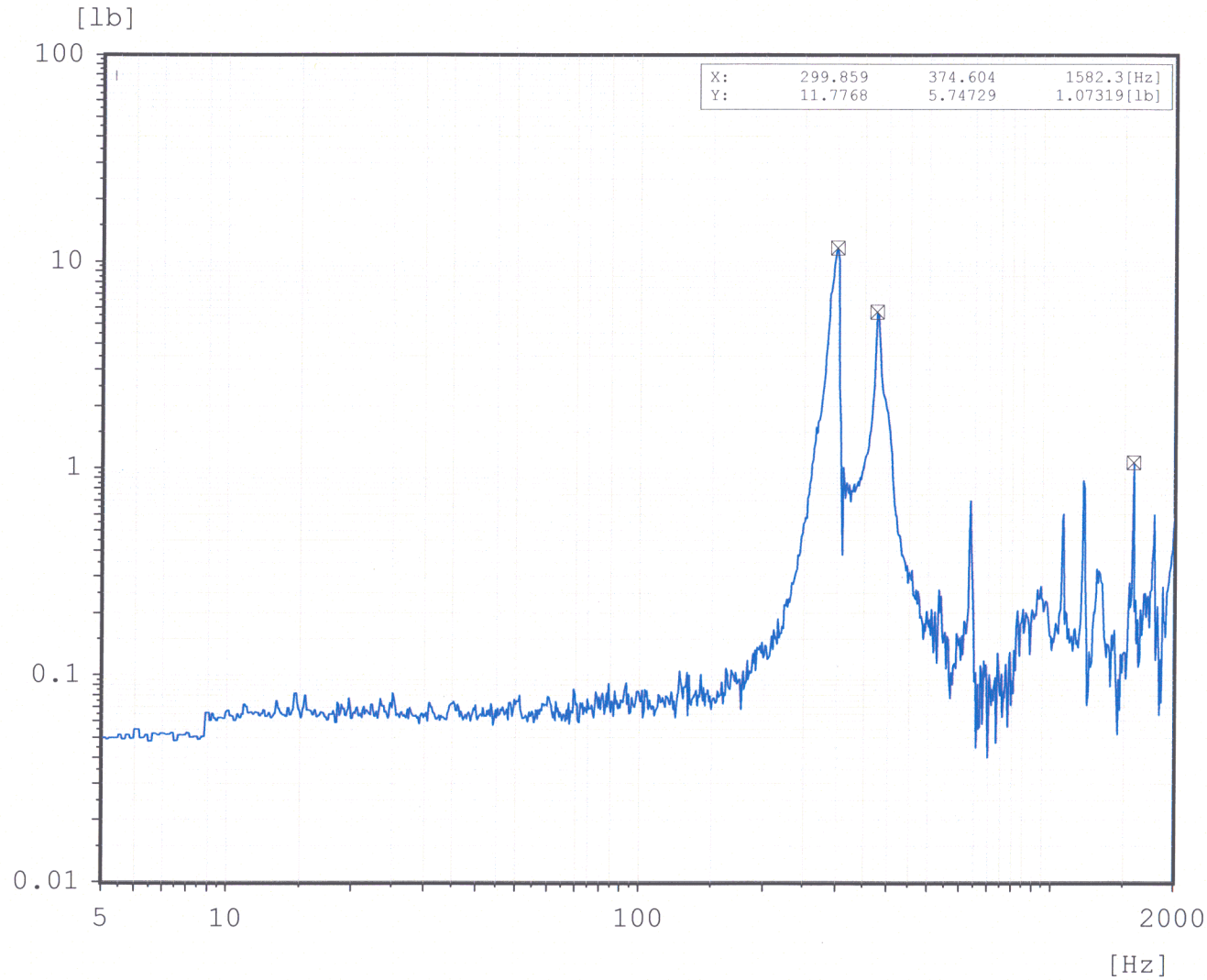

Chan.no: 7
Chan.type: W RMS
Sweep type: logarithmic
Sweeps done: 1
Sweeps req.: 1
Sweep direct.: up
Sweep rate: 4.00 Oct/min
Contr.strat.: Maximum
Unit: lb
Contr.strat.: Closed loop

-- Testing time --
elapsed: 000:02:09
remaining: 000:00:00

Date: 09-09-04
Time: 12:41:56

964#1/Amp #1/ M+P #2

PERFORMANCE VERIFICATION MATRIX - PFM PMW BDA - S/N 10209800-2-012

BDA Performance

Item	D. Value	Min Perf	Measured Median	Unit	Reference	Note
Number of bad optical pixels	= 9	= 22	0		BDA-PER-01	
(NEP _{photon} /NEP _{total}) ² (derived)	> 0.63	> 0.53	0.514		BDA-PER-02	at 18.5 mVrms bias
Optical efficiency*	> 0.85	> 0.65	0.71		BDA-PER-03	
Detector time constant	< 13	< 32	5.6	ms	BDA-PER-06	at 20 mV bias
V _{max} ***	< 11***		5.9	mVrms	BDA-DRCU-22	max over dark array
Calibration uniformity**	> 0.99	> 0.99	N/M		BDA-PER-08	
Cross-talk (n-n)**	< 0.01	< 0.05	N/M		BDA-PER-09	
Cross-talk (non n-n)**	< 0.001	< 0.001	N/M		BDA-PER-09	
1/f knee frequency	< 30	< 100	43.0	mHz	BDA-PER-10	at 21.2 mVrms bias
Average conducted heat load from 1.7 K	< 1.6	< 3.0	< 2.3	uW	BDA-TEC-06	

BDA Design Values (at 300 mK)

Item	Target	Measured Median	Unit	Reference	Note
R0	180.0	83.7	Ohms	BDA-SSSD	
Delta	41.8	41.6	K	BDA-SSSD	
R300	24.0	10.8	MOhms	BDA-SSSD	
G300	53.0	56.8	pW/K	BDA-SSSD	
Beta	1.50	1.74		BDA-SSSD	
C300	1.00	0.61	pJ/K	BDA-SSSD	
R _{lr}	10.0	8.3	MOhms	BDA-SSSD	room temp
Dark Sdc	5.9	4.1	e8 V/W	BDA-SSSD	at 21.2 mVrms bias
Dark NEP (1 Hz), incl 10 nV/rtHz amp. noise	3.5	5.4	e-17 W/rtHz	derived	at 21.2 mVrms bias
Dark NEP (0.1 Hz), incl 10 nV/rtHz amp. noise	3.5	5.8	e-17 W/rtHz	derived	at 21.2 mVrms bias
V _{max}	5.8	5.1	mVrms	BDA-SSSD	median over dark array
BDA temperature rise from 1.7 K	< 10	10	mK	BDA-HCO-1	
BDA thermal time constant	~ 100	N/M	s	BDA-HCO-2	waiver issued

*assumes v_{lower} = 1.02 v_{cutoff}

**not tested

***Thermistor and Fixed Resistor values are not included

T1 saturates at 27.5 mV bias at 300 mK

T2 saturates at 25.2 mV bias at 300 mK

R1 saturates at 42.9 mV bias

R2 saturates at 45.2 mV bias

Pixel Performance											
Item	DV	MP									
BDA connector			J01	J01	J01	J01	J01	J01	J01	J01	J01
BDA pins			1,26	2,27	3,28	4,29	5,30	6,31	7,32	8,33	9,34
BoDAC Connector			4	4	4	4	4	4	4	4	4
Channel ID			1	2	3	4	5	6	7	8	9
Detector ID			A7	A6	B6	C7	A5	B5	C6	D6	B4
BDA Pixel Operability			Yes	Yes	Yes	Yes	Yes	Yes	Yes	Yes	Yes
BoDAC channel Operability	N/A	N/A	Yes	Yes	Yes	Yes	Yes	Yes	Yes	Yes	Yes
Noisy BoDAC channel***	N/A	N/A	No	No	No	No	Yes	Yes	No	No	No
(NEPphoton/NEPtotal)^2 (derived)	> 0.63	> 0.53	0.51	0.50	0.50	0.49	0.51	0.50	0.51	0.51	0.54
Optical efficiency*	> 0.85	> 0.65	0.70	0.70	0.70	0.70	0.76	0.67	0.68	0.70	0.69
Detector time constant	< 13	< 32	6.17	6.51	6.87	5.54	6.43	5.29	5.75	5.23	5.75
Calibration uniformity**	> 0.99	> 0.99	N/A	N/A	N/A	N/A	N/A	N/A	N/A	N/A	N/A
Cross-talk (n-n)**	< 0.01	< 0.05	N/A	N/A	N/A	N/A	N/A	N/A	N/A	N/A	N/A
Cross-talk (non n-n)**	< 0.001	< 0.001	N/A	N/A	N/A	N/A	N/A	N/A	N/A	N/A	N/A
1/f knee frequency	< 30	< 100	39	28	48	47	< 30	45	56	47	34
Pixel Design Values											
Item	Target										
R0	180.0		72.7	74.5	68.4	67.5	69.9	89.7	75.7	67.7	90.7
Delta	41.8		42.1	41.7	42.3	41.9	42.6	40.3	42.1	42.5	42.0
G300	53		57.4	57.6	57.9	58.4	59.3	59.5	59.1	59.2	51.6
Beta	1.5		1.76	1.75	1.80	1.77	1.77	1.70	1.79	1.77	1.78
C300	1.00		0.69	0.73	0.77	0.62	0.74	0.59	0.66	0.59	0.60
Gamma	1 (fixed)		1.0	1.0	1.0	1.0	1.0	1.0	1.0	1.0	1.0
R300	24.1		10.1	9.8	9.8	9.2	10.5	9.7	10.6	10.0	12.5
Rlr+	10.00		8.48	8.36	8.44	8.64	8.52	8.48	8.56	8.55	8.70
Rlr-	10.00		8.44	8.20	8.50	8.44	8.40	8.56	8.48	8.62	8.52
Dark Sdc	5.9		4.1	4.0	4.0	4.0	4.1	4.0	4.1	4.1	4.4
Dark NEP (1 Hz), incl 10 nV/rtHz amp. noise	3.5		5.95	6.49	5.02	6.90	N/M	N/M	4.98	5.19	4.73
Dark NEP (0.1 Hz), incl 10 nV/rtHz amp. noise	3.5		6.29	6.58	5.41	5.76	N/M	N/M	5.82	5.67	5.14
Vmax	10.3		4.97	4.90	4.89	4.76	5.11	4.98	5.13	5.00	5.20
*assumes vlower = 1.02 vcutoff											
**not tested											
***BoDAC noisy channel data are given for information in "Mather Dark" but excluded from "Pixel" so they are not counted in the BDA median											

Pixel Performance											
Item											
BDA connector	J01	J01	J01	J01	J01	J01	J01	J01	J01	J01	J01
BDA pins	10,35	11,36	12,37	13,38	14,39	15,40	16,41	17,42	18,43	19,44	20,45
BoDAC Connector	4	4	4	4	4	4	4	4	4	4	4
Channel ID	10	11	12	13	14	15	16	17	18	19	20
Detector ID	C5	D4	A4	C4	B3	C3	B2	D2	A3	A2	C2
BDA Pixel Operability	Yes	Yes	Yes	Yes	Yes	Yes	Yes	Yes	Yes	Yes	Yes
BoDAC channel Operability	Yes	Yes	Yes	Yes	Yes	Yes	Yes	Yes	Yes	Yes	Yes
Noisy BoDAC channel***	Yes	No	No	No	No	Yes	No	No	No	No	No
(NEPphoton/NEPtotal)^2 (derived)	0.56	0.55	0.52	0.53	0.53	0.56	0.53	0.53	0.53	0.52	0.53
Optical efficiency*	0.68	0.71	0.79	0.69	0.70	0.72	0.71	0.67	0.66	0.75	0.65
Detector time constant	5.37	4.81	6.53	5.01	6.86	5.94	6.17	5.87	6.08	5.62	5.78
Calibration uniformity**	N/A	N/A	N/A	N/A	N/A	N/A	N/A	N/A	N/A	N/A	N/A
Cross-talk (n-n)**	N/A	N/A	N/A	N/A	N/A	N/A	N/A	N/A	N/A	N/A	N/A
Cross-talk (non n-n)**	N/A	N/A	N/A	N/A	N/A	N/A	N/A	N/A	N/A	N/A	N/A
1/f knee frequency	51	43	37	47	36	20	29	36	20	34	24
Pixel Design Values											
Item											
R0	98.0	89.3	82.9	78.9	87.0	105.5	85.6	96.7	88.7	97.1	97.6
Delta	42.4	42.7	41.7	42.6	41.8	41.8	41.8	41.1	41.6	40.6	41.1
G300	52.1	53.5	51.6	53.5	54.1	55.4	53.8	54.2	52.6	52.9	53.4
Beta	1.73	1.73	1.75	1.78	1.74	1.69	1.73	1.75	1.77	1.67	1.79
C300	0.57	0.52	0.68	0.54	0.74	0.65	0.66	0.63	0.64	0.58	0.61
Gamma	1.0	1.0	1.0	1.0	1.0	1.0	1.0	1.0	1.0	1.0	1.0
R300	14.3	13.6	11.0	11.8	11.7	14.2	11.4	11.8	11.5	11.0	11.9
Rlr+	8.56	8.76	8.60	8.64	8.68	8.64	8.56	8.84	8.68	8.68	8.84
Rlr-	8.52	8.54	8.68	8.54	8.64	8.52	8.60	8.56	8.60	8.62	8.65
Dark Sdc	4.6	4.5	4.3	4.3	4.3	4.5	4.3	4.3	4.3	4.3	4.4
Dark NEP (1 Hz), incl 10 nV/rHz amp. noise	N/M	5.06	5.10	4.77	6.97	N/M	5.76	5.44	6.12	5.30	6.11
Dark NEP (0.1 Hz), incl 10 nV/rHz amp. noise	N/M	5.33	5.43	5.07	5.59	N/M	5.92	5.66	6.44	5.61	6.29
Vmax	5.60	5.52	4.88	5.14	5.15	5.73	5.07	5.17	5.03	4.94	5.16
*assumes vlower = 1.02 vcutoff											
**not tested											
***BoDAC noisy channel data are given for inform:											

Pixel Performance												
Item	J01	J01	J01	J01	J02	J02	J02	J02	J02	J02	J02	J02
BDA connector	J01	J01	J01	J01	J02	J02	J02	J02	J02	J02	J02	J02
BDA pins	21,46	22,47	23,48	24,49	1,26	2,27	3,28	4,29	5,30	6,31	7,32	
BoDAC Connector	4	4	4	4	1	1	1	1	1	1	1	1
Channel ID	21	22	23	24	1	2	3	4	5	6	7	
Detector ID	B1	A1	DK1	C1	E7	D7	F7	E8	G8	F8	E9	
BDA Pixel Operability	Yes	Yes	Yes	Yes	Yes	Yes	Yes	Yes	Yes	Yes	Yes	Yes
BoDAC channel Operability	Yes	Yes	Yes	Yes	Yes	Yes	Yes	Yes	Yes	Yes	Yes	Yes
Noisy BoDAC channel***	No	No	No	No	No	No	Yes	No	No	No	No	No
(NEPphoton/NEPtotal)^2 (derived)	0.53	0.51	N/A	0.55	0.50	0.49	0.50	0.49	0.51	0.51	0.51	0.54
Optical efficiency*	0.73	0.78	N/M	0.76	0.69	0.72	0.74	0.70	0.65	0.67	0.71	
Detector time constant	8.41	7.34	5.40	6.67	5.00	5.01	5.09	5.08	5.24	5.62	4.56	
Calibration uniformity**	N/A	N/A	N/A	N/A	N/A	N/A	N/A	N/A	N/A	N/A	N/A	N/A
Cross-talk (n-n)**	N/A	N/A	N/A	N/A	N/A	N/A	N/A	N/A	N/A	N/A	N/A	N/A
Cross-talk (non n-n)**	N/A	N/A	N/A	N/A	N/A	N/A	N/A	N/A	N/A	N/A	N/A	N/A
1/f knee frequency	23	24	31	29	57	60	81	56	20	28	41	
Pixel Design Values												
Item	J01	J01	J01	J01	J02	J02	J02	J02	J02	J02	J02	J02
R0	90.1	95.3	81.4	90.5	77.1	62.4	77.0	68.4	83.2	76.2	79.1	
Delta	41.7	40.2	42.3	42.6	41.4	42.2	41.5	41.7	41.1	42.0	43.1	
G300	53.7	53.2	52.4	52.7	60.0	59.7	60.2	60.6	58.4	60.1	59.7	
Beta	1.72	1.64	1.74	1.72	1.71	1.78	1.72	1.75	1.72	1.75	1.75	
C300	0.89	0.76	0.56	0.71	0.57	0.57	0.59	0.59	0.59	0.65	0.53	
Gamma	1.0	1.0	1.0	1.0	1.0	1.0	1.0	1.0	1.0	1.0	1.0	
R300	11.8	10.1	11.6	13.5	9.7	8.8	9.8	9.0	10.1	10.5	12.7	
Rlr+	8.77	8.68	8.88	8.72	8.20	8.28	8.28	8.24	8.32	8.30	8.26	
Rlr-	8.64	8.64	8.68	8.68	8.32	8.32	8.24	8.28	8.32	8.28	8.32	
Dark Sdc	4.4	4.2	4.4	4.5	3.9	3.9	4.0	3.9	4.0	4.0	4.3	
Dark NEP (1 Hz), incl 10 nV/rHz amp. noise	5.13	5.93	5.13	5.50	5.27	5.10	N/M	5.62	7.65	6.05	5.81	
Dark NEP (0.1 Hz), incl 10 nV/rHz amp. noise	5.35	6.23	5.55	5.89	5.65	5.58	N/M	6.29	7.98	6.50	6.16	
Vmax	5.15	4.73	5.04	5.43	5.06	4.76	5.08	4.87	5.08	5.24	5.74	
*assumes vlower = 1.02 vcutoff												
**not tested												
***BoDAC noisy channel data are given for inform:												

Pixel Performance											
Item											
BDA connector	J02	J02	J02	J02	J02	J02	J02	J02	J02	J02	J02
BDA pins	8,33	9,34	10,35	11,36	12,37	13,38	14,39	15,40	16,41	17,42	18,43
BoDAC Connector	1	1	1	1	1	1	1	1	1	1	1
Channel ID	8	9	10	11	12	13	14	15	16	17	18
Detector ID	G9	D9	F9	E10	G10	F10	E11	G11	F11	E12	G12
BDA Pixel Operability	Yes	Yes	Yes	Yes	Yes	Yes	Yes	Yes	Yes	Yes	Yes
BoDAC channel Operability	Yes	Yes	Yes	Yes	Yes	Yes	Partial	Yes	Yes	Yes	Yes
Noisy BoDAC channel***	No	No	No	Yes	No	No	N/A	Yes	No	No	No
(NEPphoton/NEPtotal)^2 (derived)	0.51	0.53	0.50	0.51	0.48	0.51	0.51	0.50	0.49	0.54	0.51
Optical efficiency*	0.70	0.70	0.72	0.70	0.74	0.73	N/M	0.67	0.74	0.70	0.76
Detector time constant	5.31	5.91	4.66	5.01	6.36	5.04	N/M	4.77	5.86	5.66	5.04
Calibration uniformity**	N/A	N/A	N/A	N/A	N/A	N/A	N/A	N/A	N/A	N/A	N/A
Cross-talk (n-n)**	N/A	N/A	N/A	N/A	N/A	N/A	N/A	N/A	N/A	N/A	N/A
Cross-talk (non n-n)**	N/A	N/A	N/A	N/A	N/A	N/A	N/A	N/A	N/A	N/A	N/A
1/f knee frequency	48	33	54	N/M	61	57	N/M	N/A	53	34	58
Pixel Design Values											
Item											
R0	77.0	83.5	80.7	74.6	71.9	78.3	76.9	73.1	76.5	84.4	79.8
Delta	41.6	42.4	41.4	42.0	40.9	41.7	42.1	41.6	41.2	42.9	41.3
G300	60.9	61.7	60.6	61.4	60.2	61.6	61.2	61.1	61.4	61.5	59.6
Beta	1.71	1.69	1.78	1.79	1.73	1.76	1.75	1.70	1.69	1.73	1.71
C300	0.61	0.70	0.54	0.59	0.72	0.59	N/M	0.55	0.67	0.67	0.57
Gamma	1.0	1.0	1.0	1.0	1.0	1.0	1.0	1.0	1.0	1.0	1.0
R300	10.1	12.1	10.2	10.3	8.5	10.3	10.7	9.5	9.3	13.2	10.0
Rlr+	8.36	8.28	8.31	8.42	8.32	8.34	8.39	8.32	8.36	8.41	8.40
Rlr-	8.38	8.32	8.32	8.42	8.34	8.40	8.44	8.41	8.44	8.50	8.48
Dark Sdc	4.0	4.2	4.0	4.0	3.8	4.0	4.1	3.9	3.9	4.3	4.0
Dark NEP (1 Hz), incl 10 nV/rHz amp. noise	5.40	6.37	6.24	N/M	5.59	5.52	N/M	N/M	5.50	6.55	5.54
Dark NEP (0.1 Hz), incl 10 nV/rHz amp. noise	6.16	6.79	6.01	N/M	6.18	6.07	N/M	N/M	6.20	6.98	5.93
Vmax	5.17	5.72	5.16	5.21	4.69	5.23	5.32	5.02	4.98	5.91	5.08
*assumes vlower = 1.02 vcutoff											
**not tested											
***BoDAC noisy channel data are given for inform:											

Pixel Performance												
Item	J02	J02	J02	J02	J02	J02	J03	J03	J03	J03	J03	
BDA connector	J02	J02	J02	J02	J02	J02	J03	J03	J03	J03	J03	
BDA pins	19,44	20,45	21,46	22,47	23,48	24,49	1,26	2,27	3,28	4,29	5,30	
BoDAC Connector	1	1	1	1	1	1	6	6	6	6	6	
Channel ID	19	20	21	22	23	24	1	2	3	4	5	
Detector ID	F12	G13	DK2	SH	SH	R2	A13	T1	B12	C13	A12	
BDA Pixel Operability	Yes	Yes	Yes	Yes	Yes	Yes	Yes	Yes	Yes	Yes	Yes	
BoDAC channel Operability	Yes	Yes	Yes	Yes	Yes	Yes	Yes	Yes	Yes	Yes	Yes	
Noisy BoDAC channel***	No	Yes	No	No	No	No	No	No	Yes	No	No	
(NEPphoton/NEPtotal)^2 (derived)	0.51	0.50	N/A	N/M	N/M	N/M	0.52	N/M	0.53	0.52	0.53	
Optical efficiency*	0.70	0.77	N/M	N/M	N/M	N/M	0.80	N/M	0.80	0.79	0.75	
Detector time constant	4.24	8.04	N/M	N/M	N/M	N/M	N/A	N/M	5.17	N/A	5.83	
Calibration uniformity**	N/A	N/A	N/A	N/A	N/A	N/A	N/A	N/A	N/A	N/A	N/A	
Cross-talk (n-n)**	N/A	N/A	N/A	N/A	N/A	N/A	N/A	N/A	N/A	N/A	N/A	
Cross-talk (non n-n)**	N/A	N/A	N/A	N/A	N/A	N/A	N/A	N/A	N/A	N/A	N/A	
1/f knee frequency	39	21	31	N/M	N/M	13	39	40	55	45	54	
Pixel Design Values												
Item	J02	J02	J02	J02	J02	J02	J03	J03	J03	J03	J03	
R0	90.1	86.2	71.9	705.9	470.7	5.46E+06	101.3	89.5	90.7	94.6	83.6	
Delta	41.4	40.6	42.8	1.8	1.4	0.0	40.3	41.0	41.6	40.7	42.1	
G300	69.3	61.7	58.6	-0.1	0.0	N/M	39.1	5849.1	49.9	50.3	50.1	
Beta	1.76	1.66	1.72	0.39	1.67	N/M	1.78	6.72	1.75	1.74	1.77	
C300	0.54	0.92	N/M	N/A	N/A	N/A	0.74	N/A	0.54	N/A	0.61	
Gamma	1.0	1.0	1.0	1.0	1.0	1.0	1.0	1.0	1.0	1.0	1.0	
R300	11.3	9.7	11.1	N/M	N/M	5.5	11.0	10.8	11.8	10.9	11.6	
Rlr+	8.44	8.47	8.44	8.48	8.68	8.52	8.10	8.12	8.16	8.12	8.16	
Rlr-	8.52	8.48	8.52	8.56	8.55	8.56	8.08	8.08	8.10	8.08	8.10	
Dark Sdc	4.0	4.0	4.2	N/M	N/M	N/M	4.2	N/M	4.2	4.1	4.2	
Dark NEP (1 Hz), incl 10 nV/rtHz amp. noise	6.43	N/M	6.12	N/M	N/M	N/M	5.57	N/M	N/M	5.53	4.87	
Dark NEP (0.1 Hz), incl 10 nV/rtHz amp. noise	7.03	N/M	6.47	N/M	N/M	N/M	6.06	N/M	N/M	5.88	5.19	
Vmax	5.71	5.06	5.32	N/M	N/M	N/M	4.43	N/M	4.96	4.78	4.94	
*assumes vlower = 1.02 vcutoff												
**not tested												
***BoDAC noisy channel data are given for inform:												

Pixel Performance											
Item											
BDA connector	J03	J03	J03	J03	J03	J03	J03	J03	J03	J03	J03
BDA pins	6,31	7,32	8,33	9,34	10,35	11,36	12,37	13,38	14,39	15,40	16,41
BoDAC Connector	6	6	6	6	6	6	6	6	6	6	6
Channel ID	6	7	8	9	10	11	12	13	14	15	16
Detector ID	D12	C12	B11	A11	E13	D11	C11	B10	A10	D10	B9
BDA Pixel Operability	Yes	Yes	Yes	Yes	Yes	Yes	Yes	Yes	Yes	Yes	Yes
BoDAC channel Operability	Yes	Yes	Yes	Yes	Yes	Yes	Yes	Yes	Yes	Yes	Yes
Noisy BoDAC channel***	No	No	Yes	No	No	No	No	No	No	No	No
(NEPphoton/NEPtotal)^2 (derived)	0.54	0.55	0.53	0.53	0.53	0.51	0.53	0.56	0.52	0.53	0.52
Optical efficiency*	0.76	0.74	0.71	0.74	0.81	0.73	0.76	0.72	0.78	0.73	0.70
Detector time constant	6.21	5.96	5.42	6.16	6.64	5.60	6.24	6.83	4.96	4.97	6.92
Calibration uniformity**	N/A	N/A	N/A	N/A	N/A	N/A	N/A	N/A	N/A	N/A	N/A
Cross-talk (n-n)**	N/A	N/A	N/A	N/A	N/A	N/A	N/A	N/A	N/A	N/A	N/A
Cross-talk (non n-n)**	N/A	N/A	N/A	N/A	N/A	N/A	N/A	N/A	N/A	N/A	N/A
1/f knee frequency	56	54	131	43	48	47	51	42	47	58	46
Pixel Design Values											
Item											
R0	110.4	88.2	90.5	89.8	94.3	89.8	87.8	93.7	76.0	103.2	80.1
Delta	40.8	42.6	41.5	41.8	41.1	40.9	41.7	42.9	42.3	40.7	42.1
G300	51.4	51.4	52.0	51.8	51.1	52.4	52.4	52.4	50.9	51.5	51.3
Beta	1.73	1.77	1.73	1.75	1.68	1.73	1.75	1.72	1.80	1.74	1.78
C300	0.66	0.64	0.58	0.66	0.70	0.60	0.67	0.74	0.53	0.53	0.74
Gamma	1.0	1.0	1.0	1.0	1.0	1.0	1.0	1.0	1.0	1.0	1.0
R300	12.7	13.1	11.6	12.1	11.4	10.5	11.5	14.7	10.9	11.8	11.1
Rlr+	8.20	8.16	8.16	8.24	8.18	8.18	8.24	8.28	8.20	8.24	8.24
Rlr-	8.13	8.16	8.12	8.14	8.14	8.16	8.12	8.16	8.10	8.16	8.18
Dark Sdc	4.3	4.3	4.2	4.2	4.2	4.1	4.2	4.5	4.1	4.2	4.2
Dark NEP (1 Hz), incl 10 nV/rtHz amp. noise	5.23	4.97	N/M	5.33	5.39	5.40	4.89	4.98	4.75	4.84	4.99
Dark NEP (0.1 Hz), incl 10 nV/rtHz amp. noise	5.64	5.25	N/M	5.85	5.66	5.77	5.33	5.50	5.24	5.47	5.39
Vmax	5.27	5.30	5.02	5.11	4.93	4.80	5.02	5.67	4.81	5.06	4.88
*assumes vlower = 1.02 vcutoff											
**not tested											
***BoDAC noisy channel data are given for inform:											

Pixel Performance											
Item											
BDA connector	J03	J03	J03	J03	J03	J03	J03	J03	J03	J04	J04
BDA pins	17,42	18,43	19,44	20,45	21,46	22,47	23,48	24,49		1,26	2,27
BoDAC Connector	6	6	6	6	6	6	6	6		2	2
Channel ID	17	18	19	20	21	22	23	24		1	2
Detector ID	C10	C9	A9	B8	A8	C8	C8	B7		R1	G1
BDA Pixel Operability	Yes	Yes	Yes	Yes	Yes	Yes	Yes	Yes		Yes	Yes
BoDAC channel Operability	Yes	Yes	Yes	Yes	Yes	Yes	Yes	Yes		Yes	Yes
Noisy BoDAC channel***	No	Yes	No	No	No	No	No	No		No	No
(NEPphoton/NEPtotal)^2 (derived)	0.53	0.51	0.56	0.54	0.52	0.55	0.51	0.51		N/M	0.52
Optical efficiency*	0.69	0.71	0.74	0.74	0.73	0.75	0.71	0.72		N/M	0.73
Detector time constant	5.09	5.50	6.18	6.07	5.96	5.72	5.50	5.36		N/M	8.69
Calibration uniformity**	N/A	N/A	N/A	N/A	N/A	N/A	N/A	N/A		N/A	N/A
Cross-talk (n-n)**	N/A	N/A	N/A	N/A	N/A	N/A	N/A	N/A		N/A	N/A
Cross-talk (non n-n)**	N/A	N/A	N/A	N/A	N/A	N/A	N/A	N/A		N/A	N/A
1/f knee frequency	30	52	43	45	35	40	46	34		N/M	59
Pixel Design Values											
Item											
R0	83.8	89.0	101.7	89.0	74.9	84.9	86.2	79.4		5.36E+06	98.3
Delta	42.2	40.7	42.5	42.3	42.2	43.2	41.2	41.6		0.0	40.7
G300	52.0	51.1	51.2	51.2	49.5	51.0	50.3	49.8		N/M	56.0
Beta	1.76	1.73	1.74	1.75	1.80	1.75	1.79	1.77		N/M	1.64
C300	0.55	0.58	0.66	0.65	0.62	0.61	0.57	0.56		N/A	0.97
Gamma	1.0	1.0	1.0	1.0	1.0	1.0	1.0	1.0		1.0	1.0
R300	11.9	10.2	15.0	12.7	10.6	13.8	10.5	10.4		5.4	11.2
Rlr+	8.28	8.22	8.20	8.32	8.24	8.16	8.36	8.20		7.76	7.80
Rlr-	8.12	8.12	8.18	8.16	8.12	8.16	8.12	8.10		7.92	7.98
Dark Sdc	4.2	4.1	4.5	4.3	4.1	4.4	4.1	4.1		N/M	4.0
Dark NEP (1 Hz), incl 10 nV/rtHz amp. noise	6.12	N/M	4.66	4.66	5.23	4.85	4.73	5.37		N/M	5.59
Dark NEP (0.1 Hz), incl 10 nV/rtHz amp. noise	6.58	N/M	4.95	5.15	5.51	5.38	5.06	5.91		N/M	6.14
Vmax	5.08	4.67	5.65	5.20	4.68	5.40	4.70	4.66		N/M	5.10
*assumes vlower = 1.02 vcutoff											
**not tested											
***BoDAC noisy channel data are given for inform:											

Pixel Performance											
Item											
BDA connector	J04	J04	J04	J04	J04	J04	J04	J04	J04	J04	J04
BDA pins	3,28	4,29	5,30	6,31	7,32	8,33	9,34	10,35	11,36	12,37	13,38
BoDAC Connector	2	2	2	2	2	2	2	2	2	2	2
Channel ID	3	4	5	6	7	8	9	10	11	12	13
Detector ID	T2	E1	D1	F1	E2	G2	F2	G3	E3	D3	F3
BDA Pixel Operability	Yes	Yes	Yes	Yes	Yes	Yes	Yes	Yes	Yes	Yes	Yes
BoDAC channel Operability	Yes	Yes	Yes	Yes	Yes	Yes	Yes	Yes	Yes	Yes	Yes
Noisy BoDAC channel***	No	Yes	No	Yes	No	Yes	No	No	No	No	No
(NEPphoton/NEPtotal)^2 (derived)	N/M	0.52	0.51	0.52	0.52	0.52	0.50	0.50	0.50	0.51	0.50
Optical efficiency*	N/M	0.73	0.69	0.73	0.72	0.71	0.69	0.65	0.67	0.70	0.65
Detector time constant	N/M	5.57	4.55	4.80	4.78	6.49	5.20	9.32	5.06	4.79	5.08
Calibration uniformity**	N/A	N/A	N/A	N/A	N/A	N/A	N/A	N/A	N/A	N/A	N/A
Cross-talk (n-n)**	N/A	N/A	N/A	N/A	N/A	N/A	N/A	N/A	N/A	N/A	N/A
Cross-talk (non n-n)**	N/A	N/A	N/A	N/A	N/A	N/A	N/A	N/A	N/A	N/A	N/A
1/f knee frequency	36	43	44	57	21	30	42	40	46	47	49
Pixel Design Values											
Item											
R0	98.5	89.5	79.9	88.1	98.2	85.1	72.9	76.2	77.5	90.1	78.6
Delta	41.3	41.3	41.5	41.5	40.7	41.4	42.0	41.6	41.2	41.3	41.6
G300	5371.2	55.3	56.2	55.9	55.5	55.4	64.7	63.9	63.3	63.5	64.7
Beta	5.87	1.67	1.70	1.68	1.68	1.66	1.71	1.69	1.69	1.75	1.71
C300	N/A	0.62	0.51	0.54	0.53	0.72	0.64	1.13	0.61	0.59	0.62
Gamma	1.0	1.0	1.0	1.0	1.0	1.0	1.0	1.0	1.0	1.0	1.0
R300	12.2	11.1	10.2	11.3	11.3	10.7	10.0	9.9	9.6	11.2	10.2
Rlr+	7.82	7.88	7.84	7.85	7.84	7.90	7.88	7.88	7.92	7.88	7.92
Rlr-	7.90	7.92	8.00	7.92	7.96	8.00	7.96	7.99	8.00	8.00	8.04
Dark Sdc	N/M	4.0	3.9	4.0	4.0	4.0	3.8	3.8	3.8	4.0	3.9
Dark NEP (1 Hz), incl 10 nV/rtHz amp. noise	N/M	N/M	5.49	N/M	5.32	N/M	5.39	5.96	5.37	5.53	5.34
Dark NEP (0.1 Hz), incl 10 nV/rtHz amp. noise	N/M	N/M	5.62	N/M	5.66	N/M	5.92	6.37	5.85	6.19	5.82
Vmax	N/M	5.05	4.91	5.15	5.16	5.00	5.20	5.16	5.09	5.49	5.30
*assumes vlower = 1.02 vcutoff											
**not tested											
***BoDAC noisy channel data are given for inform:											

Pixel Performance											
Item											
BDA connector	J04	J04	J04	J04	J04	J04	J04	J04	J04	J04	J04
BDA pins	14,39	15,40	16,41	17,42	18,43	19,44	20,45	21,46	22,47	23,48	24,49
BoDAC Connector	2	2	2	2	2	2	2	2	2	2	2
Channel ID	14	15	16	17	18	19	20	21	22	23	24
Detector ID	G4	E4	F4	E5	D5	F5	G5	E6	G6	F6	G7
BDA Pixel Operability	Yes	Yes	Yes	Yes	Yes	Yes	Yes	Yes	Yes	Yes	Yes
BoDAC channel Operability	Yes	Yes	Yes	Yes	Yes	Yes	Yes	Yes	Yes	Yes	Yes
Noisy BoDAC channel***	No	No	No	Yes	No	No	No	No	No	No	No
(NEPphoton/NEPtotal)^2 (derived)	0.51	0.52	0.49	0.49	0.50	0.50	0.51	0.48	0.50	0.52	0.50
Optical efficiency*	0.67	0.65	0.68	0.72	0.67	0.67	0.66	0.75	0.70	0.67	0.73
Detector time constant	4.81	4.88	4.83	5.00	4.70	5.37	6.01	5.16	6.05	5.02	5.71
Calibration uniformity**	N/A	N/A	N/A	N/A	N/A	N/A	N/A	N/A	N/A	N/A	N/A
Cross-talk (n-n)**	N/A	N/A	N/A	N/A	N/A	N/A	N/A	N/A	N/A	N/A	N/A
Cross-talk (non n-n)**	N/A	N/A	N/A	N/A	N/A	N/A	N/A	N/A	N/A	N/A	N/A
1/f knee frequency	49	28	45	37	49	46	43	43	29	49	44
Pixel Design Values											
Item											
R0	79.6	80.3	65.9	63.1	74.8	68.7	90.5	70.3	77.3	72.4	81.1
Delta	41.7	42.2	42.2	42.3	41.9	42.4	40.9	41.4	41.4	42.7	41.3
G300	63.8	63.9	62.6	61.2	62.2	61.8	62.7	62.5	60.6	60.1	58.9
Beta	1.67	1.70	1.74	1.78	1.75	1.77	1.69	1.76	1.73	1.75	1.73
C300	0.58	0.60	0.58	0.59	0.57	0.64	0.72	0.62	0.71	0.59	0.66
Gamma	1.0	1.0	1.0	1.0	1.0	1.0	1.0	1.0	1.0	1.0	1.0
R300	10.5	11.4	9.3	9.1	10.2	10.0	10.7	8.9	9.8	11.1	10.1
Rlr+	8.04	7.98	8.02	8.04	7.94	8.00	8.06	7.92	7.96	8.00	8.01
Rlr-	8.10	8.02	8.06	8.12	8.03	8.08	8.07	8.04	8.08	8.05	8.05
Dark Sdc	4.0	4.0	3.8	3.8	3.9	3.9	4.0	3.7	3.9	4.0	3.9
Dark NEP (1 Hz), incl 10 nV/rtHz amp. noise	5.22	7.00	5.13	N/M	5.26	5.56	5.39	5.87	5.83	4.97	5.71
Dark NEP (0.1 Hz), incl 10 nV/rtHz amp. noise	5.62	7.22	5.55	N/M	5.55	5.95	5.82	6.08	6.49	5.30	5.94
Vmax	5.35	5.57	4.97	4.85	5.19	5.11	5.37	4.86	5.03	5.31	5.03
*assumes vlower = 1.02 vcutoff											
**not tested											
***BoDAC noisy channel data are given for inform:											

Pixel Performance			
Item	Unit	Reference	Note
BDA connector			
BDA pins			
BoDAC Connector			
Channel ID			
Detector ID			
BDA Pixel Operability			
BoDAC channel Operability			
Noisy BoDAC channel***			
(NEP _{photon} /NEP _{total}) ² (derived)		BDA-PER-02	at 30 mV bias
Optical efficiency*		BDA-PER-05	
Detector time constant	ms	BDA-PER-07	at 28 mV bias
Calibration uniformity**		BDA-PER-08	
Cross-talk (n-n)**		BDA-PER-09	
Cross-talk (non n-n)**		BDA-PER-09	
1/f knee frequency	mHz	BDA-PER-10	at 21.2 mV bias
Pixel Design Values			
Item	Unit	Reference	Note
R0	Ohms	BDA-SSSD	
Delta	K	BDA-SSSD	
G300	pW/K	BDA-SSSD	
Beta		BDA-SSSD	
C300	pJ/K	BDA-SSSD	
Gamma			
R300	MOhms	BDA-SSSD	
R _{lr+}	MOhms	BDA-SSSD	room temp
R _{lr-}	MOhms	BDA-SSSD	room temp
Dark Sdc	e ⁸ V/W	BDA-SSSD	at 21.2 mV bias
Dark NEP (1 Hz), incl 10 nV/rtHz amp. noise	e-17 W/rtHz	derived	at 21.2 mV bias
Dark NEP (0.1 Hz), incl 10 nV/rtHz amp. noise	e-17 W/rtHz	derived	at 21.2 mV bias
V _{max}	mVrms	BDA-DRCU-22	
*assumes v _{lower} = 1.02 v _{cutoff}			
**not tested			
***BoDAC noisy channel data are given for inform:			

Symbol	Units	Value	Value	Value	Value	Value	Value	Value	Value	Value	Value	Value	Value	Value	
T0	K	0.3	Base Temperature												
Vn	nV/rtHz	10	Amplifier Voltage Noise												
Q	pW	0	Absorbed Power Onto Bolometer												
NEP _{photon}	1e-17 W/rtHz	0.00	Noise in Absorbed Optical Power												
Vbias	mV	21.2	Bias Across Bolometer & Load Resistors												
			Detector ID												
		Target	A7	A6	B6	C7	A5	B5	C6	D6	B4	C5	D4	A4	
Pthermal	pW	4.424	3.915	3.969	3.868	3.742	4.012	3.891	4.007	3.868	4.058	4.317	4.205	3.838	
Pelec+Q	pW	4.424	3.915	3.969	3.868	3.742	4.012	3.891	4.007	3.868	4.058	4.317	4.205	3.838	
Tbolo	K	0.37055	0.35794	0.35850	0.35671	0.35480	0.35751	0.35607	0.35741	0.35574	0.36531	0.36863	0.36562	0.36236	
T/T0		1.235	1.193	1.195	1.189	1.183	1.192	1.187	1.191	1.186	1.218	1.229	1.219	1.208	
Rbolo	Ω	7.38E+06	3.71E+06	3.58E+06	3.65E+06	3.54E+06	3.85E+06	3.74E+06	3.91E+06	3.78E+06	4.11E+06	4.45E+06	4.41E+06	3.79E+06	
Vbolo	mV	5.71	3.81	3.77	3.76	3.64	3.93	3.81	3.96	3.82	4.08	4.39	4.31	3.82	
Ibolo	nA	0.77	1.03	1.05	1.03	1.03	1.02	1.02	1.01	1.01	0.99	0.98	0.98	1.01	
A		-5.31	-5.42	-5.39	-5.44	-5.43	-5.46	-5.32	-5.43	-5.46	-5.36	-5.36	-5.40	-5.37	
C	pJ/K	1.24	0.82	0.87	0.92	0.73	0.88	0.70	0.78	0.70	0.74	0.70	0.63	0.82	
G	pW/K	72.8	78.3	78.6	79.1	78.6	80.8	79.7	81.0	80.0	73.2	74.3	75.2	71.9	
Z/R		0.069	0.138	0.137	0.145	0.157	0.137	0.156	0.142	0.148	0.103	0.084	0.095	0.117	
τ	ms	12.111	7.062	7.465	7.834	6.287	7.342	6.027	6.564	5.947	6.695	6.303	5.607	7.561	
Sdc	V/W	5.86E+08	4.07E+08	3.98E+08	4.02E+08	3.97E+08	4.10E+08	4.00E+08	4.11E+08	4.08E+08	4.40E+08	4.55E+08	4.52E+08	4.28E+08	
NEP _{johnson}	1e-17 W/rtHz	1.092	1.161	1.167	1.169	1.174	1.173	1.199	1.183	1.174	1.113	1.109	1.115	1.109	
NEP _{phonon}	1e-17 W/rtHz	2.006	2.038	2.044	2.043	2.036	2.069	2.057	2.070	2.056	1.983	2.007	2.014	1.962	
NEP _{load}	1e-17 W/rtHz	0.077	0.121	0.119	0.126	0.133	0.124	0.139	0.129	0.130	0.092	0.079	0.089	0.099	
NEP _{amp}	1e-17 W/rtHz	1.705	2.457	2.510	2.485	2.518	2.440	2.502	2.435	2.453	2.271	2.196	2.211	2.338	
NEP _{det}	1e-17 W/rtHz	3.498	4.353	4.419	4.392	4.429	4.356	4.434	4.356	4.365	4.092	4.019	4.042	4.155	
DQE		0.000	0.000	0.000	0.000	0.000	0.000	0.000	0.000	0.000	0.000	0.000	0.000	0.000	
Vn(det)	nV/rtHz	20.5	17.7	17.6	17.7	17.6	17.9	17.7	17.9	17.8	18.0	18.3	18.3	17.8	
Vn(total)	nV/rtHz	20.5	17.7	17.6	17.7	17.6	17.9	17.7	17.9	17.8	18.0	18.3	18.3	17.8	
Vn(calculated)		17.9													
Vn(measured) at 1Hz		24.38	24.2	25.9	20.2	27.4	> 40.0	28.1	20.4	21.2	20.8	72.7	22.9	21.8	
NEP(measured) at 1 Hz		3.5	5.9	6.5	5.0	6.9	> 9.8	7.0	5.0	5.2	4.7	16.0	5.1	5.1	
Vn(measured) at 0.1 Hz			25.6	26.2	21.8	22.9	90.8	30.5	23.9	23.1	22.6	74.2	24.1	23.2	
NEP(measured) at 0.1 Hz			6.3	6.6	5.4	5.8	22.2	7.6	5.8	5.7	5.1	16.3	5.3	5.4	
Vn(measured) at 1Hz no T/C*			31.2	29.5	29.4	28.1	31.1	30.0	30.3	30.2	31.2	33.2	31.9	33.5	
NEP(measured) at 1Hz no T/C			7.7	7.4	7.3	7.1	7.6	7.5	7.4	7.4	7.1	7.3	7.1	7.8	
Vn(measured) at 0.1Hz no T/C			47.4	47.4	42.1	37.1	43.5	37.7	38.1	34.8	37.6	44.8	36.8	42.9	
NEP(measured) at 0.1Hz no T/C			11.6	11.9	10.5	9.3	10.6	9.4	9.3	8.5	8.6	9.8	8.1	10.0	
* Noise under these conditions is generally worse. However the noisist pixels (highlighted in red) affected by BoDAC microphonics improved.															
These data are provided for completeness, but not used to calculate any parameters in the pixel spreadsheet.															

Symbol	Value	Value	Value	Value	Value	Value	Value	Value	Value	Value	Value	Value	Value	Value
T0														
Vn														
Q														
NEP _{photon}														
Vbias														
	C4	B3	C3	B2	D2	A3	A2	C2	B1	A1	DK1	C1	E7	D7
Pthermal	4.015	3.992	4.384	3.976	4.000	3.950	3.879	3.979	3.979	3.750	3.867	4.159	4.021	3.818
Pelec+Q	4.015	3.992	4.384	3.976	4.000	3.950	3.879	3.979	3.979	3.750	3.867	4.159	4.021	3.818
Tbolo	0.36269	0.36201	0.36618	0.36217	0.36200	0.36285	0.36206	0.36230	0.36241	0.36012	0.36210	0.36581	0.35724	0.35465
T/T0	1.209	1.207	1.221	1.207	1.207	1.209	1.207	1.208	1.208	1.200	1.207	1.219	1.191	1.182
Rbolo	4.01E+06	4.06E+06	4.63E+06	3.94E+06	4.12E+06	3.97E+06	3.87E+06	4.14E+06	4.09E+06	3.68E+06	4.00E+06	4.40E+06	3.63E+06	3.40E+06
Vbolo	4.01	4.03	4.51	3.96	4.06	3.96	3.87	4.06	4.04	3.71	3.93	4.28	3.82	3.60
Ibolo	1.00	0.99	0.97	1.00	0.98	1.00	1.00	0.98	0.99	1.01	0.98	0.97	1.05	1.06
A	-5.42	-5.38	-5.34	-5.37	-5.33	-5.35	-5.30	-5.33	-5.36	-5.28	-5.40	-5.40	-5.38	-5.45
C	0.65	0.89	0.79	0.80	0.76	0.78	0.70	0.74	1.08	0.91	0.68	0.86	0.68	0.68
G	75.1	75.1	77.6	74.6	75.3	73.6	72.5	74.9	74.3	71.9	72.6	74.2	80.9	80.4
Z/R	0.112	0.118	0.096	0.117	0.122	0.116	0.122	0.123	0.116	0.133	0.115	0.095	0.144	0.156
τ	5.800	7.929	6.926	7.136	6.778	7.041	6.498	6.683	9.728	8.456	6.239	7.770	5.715	5.683
Sdc	4.33E+08	4.33E+08	4.53E+08	4.28E+08	4.33E+08	4.31E+08	4.27E+08	4.35E+08	4.36E+08	4.17E+08	4.39E+08	4.54E+08	3.95E+08	3.86E+08
NEP _{johnson}	1.122	1.132	1.142	1.128	1.143	1.123	1.124	1.141	1.126	1.129	1.107	1.108	1.189	1.185
NEP _{photon}	2.003	2.005	2.049	1.998	2.007	1.985	1.974	1.999	1.996	1.964	1.972	2.001	2.074	2.059
NEP _{load}	0.099	0.105	0.094	0.103	0.110	0.102	0.105	0.110	0.103	0.112	0.099	0.087	0.128	0.133
NEP _{amp}	2.312	2.310	2.209	2.337	2.309	2.318	2.343	2.299	2.291	2.395	2.280	2.201	2.534	2.593
NEP _{det}	4.152	4.156	4.072	4.181	4.163	4.151	4.174	4.146	4.128	4.232	4.093	4.020	4.473	4.532
DQE	0.000	0.000	0.000	0.000	0.000	0.000	0.000	0.000	0.000	0.000	0.000	0.000	0.000	0.000
Vn(det)	18.0	18.0	18.4	17.9	18.0	17.9	17.8	18.0	18.0	17.7	18.0	18.3	17.6	17.5
Vn(total)	18.0	18.0	18.4	17.9	18.0	17.9	17.8	18.0	18.0	17.7	18.0	18.3	17.6	17.5
Vn(calculated)														
Vn(measured) at 1Hz	20.6	30.2	33.1	24.6	23.6	26.4	22.6	26.6	22.4	24.7	22.5	25.0	20.8	19.7
NEP(measured) at 1 Hz	4.8	7.0	7.3	5.8	5.4	6.1	5.3	6.1	5.1	5.9	5.1	5.5	5.3	5.1
Vn(measured) at 0.1 Hz	22.0	24.2	33.5	25.3	24.5	27.8	24.0	27.4	23.3	26.0	24.4	26.8	22.3	21.5
NEP(measured) at 0.1 H	5.1	5.6	7.4	5.9	5.7	6.4	5.6	6.3	5.3	6.2	5.6	5.9	5.6	5.6
Vn(measured) at 1Hz no	101.7	32.2	41.3	32.4	31.0	34.5	33.4	35.8	31.4	35.7	30.1	159.3	34.6	34.4
NEP(measured) at 1Hz r	23.5	7.4	9.1	7.6	7.1	8.0	7.8	8.2	7.2	8.6	6.9	35.1	8.8	8.9
Vn(measured) at 0.1Hz r	106.7	42.6	46.4	40.6	37.4	60.5	49.1	44.1	43.0	43.0	35.7	168.8	44.6	44.9
NEP(measured) at 0.1Hz	24.7	9.8	10.2	9.5	8.6	14.0	11.5	10.1	9.8	10.3	8.1	37.1	11.3	11.7
* Noise under these conc														
These data are provide														

Symbol	Value	Value	Value	Value	Value	Value	Value	Value	Value	Value	Value	Value	Value	Value
T0														
Vn														
Q														
NEP _{photon}														
Vbias														
	F7	E8	G8	F8	E9	G9	D9	F9	E10	G10	F10	E11	G11	F11
Pthermal	4.046	3.907	4.027	4.132	4.437	4.039	4.407	4.094	4.062	3.771	4.100	4.131	3.951	3.913
Pelec+Q	4.046	3.907	4.027	4.132	4.437	4.039	4.407	4.094	4.062	3.771	4.100	4.131	3.951	3.913
Tbolo	0.35735	0.35519	0.35864	0.35832	0.36238	0.35673	0.36062	0.35735	0.35627	0.35390	0.35674	0.35737	0.35552	0.35489
T/T0	1.191	1.184	1.195	1.194	1.208	1.189	1.202	1.191	1.188	1.180	1.189	1.191	1.185	1.183
Rbolo	3.67E+06	3.48E+06	3.71E+06	3.83E+06	4.31E+06	3.79E+06	4.27E+06	3.80E+06	3.88E+06	3.36E+06	3.88E+06	3.98E+06	3.65E+06	3.64E+06
Vbolo	3.85	3.69	3.87	3.98	4.37	3.91	4.34	3.95	3.97	3.56	3.99	4.06	3.80	3.77
Ibolo	1.05	1.06	1.04	1.04	1.01	1.03	1.02	1.04	1.02	1.06	1.03	1.02	1.04	1.04
A	-5.39	-5.42	-5.35	-5.41	-5.45	-5.40	-5.42	-5.38	-5.43	-5.38	-5.41	-5.43	-5.41	-5.38
C	0.70	0.69	0.71	0.78	0.64	0.73	0.84	0.65	0.70	0.85	0.70	#VALUE!	0.65	0.80
G	81.4	81.4	79.4	82.1	83.1	81.9	84.2	82.7	83.5	80.1	83.4	83.3	81.6	81.6
Z/R	0.143	0.155	0.138	0.136	0.109	0.145	0.119	0.146	0.148	0.166	0.146	0.141	0.152	0.158
τ	5.818	5.768	6.009	6.432	5.263	6.059	6.802	5.318	5.706	7.209	5.742	#VALUE!	5.423	6.655
Sdc	3.95E+08	3.86E+08	4.01E+08	4.03E+08	4.27E+08	4.01E+08	4.21E+08	3.98E+08	4.02E+08	3.81E+08	4.01E+08	4.08E+08	3.95E+08	3.93E+08
NEP _{johnson}	1.192	1.195	1.179	1.189	1.173	1.194	1.191	1.206	1.205	1.200	1.207	1.198	1.195	1.203
NEP _{photon}	2.079	2.074	2.056	2.088	2.109	2.086	2.124	2.093	2.100	2.057	2.102	2.101	2.080	2.079
NEP _{load}	0.129	0.135	0.124	0.125	0.107	0.132	0.118	0.134	0.137	0.141	0.136	0.132	0.135	0.140
NEP _{amp}	2.529	2.590	2.492	2.480	2.343	2.495	2.378	2.510	2.485	2.624	2.491	2.449	2.533	2.547
NEP _{det}	4.471	4.540	4.412	4.418	4.266	4.437	4.322	4.464	4.438	4.575	4.447	4.395	4.479	4.498
DQE	0.000	0.000	0.000	0.000	0.000	0.000	0.000	0.000	0.000	0.000	0.000	0.000	0.000	0.000
Vn(det)	17.7	17.5	17.7	17.8	18.2	17.8	18.2	17.8	17.9	17.4	17.9	17.9	17.7	17.7
Vn(total)	17.7	17.5	17.7	17.8	18.2	17.8	18.2	17.8	17.9	17.4	17.9	17.9	17.7	17.7
Vn(calculated)														
Vn(measured) at 1Hz	> 40.0	21.7	30.7	24.4	24.8	21.6	26.8	24.9	> 40.0	21.3	22.2	N/M	28.4	21.6
NEP(measured) at 1 Hz	> 10.1	5.6	7.6	6.0	5.8	5.4	6.4	6.2	> 9.9	5.6	5.5	N/M	7.2	5.5
Vn(measured) at 0.1 Hz	> 40.0	24.3	32.0	26.2	26.3	24.7	28.6	23.9	> 40.0	23.5	24.4	N/M	30.8	24.3
NEP(measured) at 0.1 H	> 10.1	6.3	8.0	6.5	6.2	6.2	6.8	6.0	> 9.9	6.2	6.1	N/M	7.8	6.2
Vn(measured) at 1Hz no	38.9	36.2	39.6	41.6	40.5	40.4	87.4	39.1	39.0	38.4	40.2	36.1	41.3	35.9
NEP(measured) at 1Hz r	9.8	9.4	9.9	10.3	9.5	10.1	20.8	9.8	9.7	10.1	10.0	8.8	10.5	9.2
Vn(measured) at 0.1Hz r	59.1	52.5	66.3	68.2	56.1	60.7	459.3	53.4	50.3	54.1	66.5	52.0	64.8	54.3
NEP(measured) at 0.1Hz	14.9	13.6	16.5	16.9	13.2	15.1	109.2	13.4	12.5	14.2	16.6	12.7	16.4	13.8
* Noise under these conc														
These data are provide														

Symbol	Value	Value	Value	Value	Value	Value	Value	Value	Value	Value	Value	Value	Value	Value
T0														
Vn														
Q														
NEP _{photon}														
Vbias														
	E12	G12	F12	G13	DK2	SH	SH	R2	A13	T1	B12	C13	A12	D12
Pthermal	4.458	3.968	4.365	3.959	4.080	#NUM!	0.005	#VALUE!	3.771	24.593	4.174	4.084	4.148	4.351
Pelec+Q	4.458	3.968	4.365	3.959	4.080	#NUM!	0.005	#VALUE!	3.771	6.541	4.174	4.084	4.148	4.351
Tbolo	0.36117	0.35688	0.35399	0.35530	0.35917	-0.23114	0.39410	#VALUE!	0.37742	0.30402	0.36905	0.36734	0.36819	0.36988
T/T0	1.204	1.190	1.180	1.184	1.197	-0.770	1.314	#VALUE!	1.258	1.013	1.230	1.224	1.227	1.233
Rbolo	4.58E+06	3.76E+06	4.45E+06	3.79E+06	3.98E+06	#NUM!	3.09E+03	#VALUE!	3.13E+06	9.96E+06	3.70E+06	3.54E+06	3.66E+06	4.00E+06
Vbolo	4.52	3.86	4.41	3.87	4.03	#NUM!	0.00	#VALUE!	3.43	8.07	3.93	3.80	3.90	4.17
Ibolo	0.99	1.03	0.99	1.02	1.01	#NUM!	1.23	#VALUE!	1.10	0.81	1.06	1.07	1.06	1.04
A	-5.45	-5.38	-5.40	-5.35	-5.46	#NUM!	-0.94	#VALUE!	-5.17	-5.81	-5.31	-5.27	-5.34	-5.25
C	0.80	0.68	0.63	1.09	#VALUE!	#VALUE!	#VALUE!	#VALUE!	0.93	#VALUE!	0.67	#VALUE!	0.75	0.81
G	84.8	80.3	92.8	81.8	79.8	#NUM!	0.1	#VALUE!	58.9	6396.5	71.6	71.5	72.1	73.7
Z/R	0.115	0.146	0.164	0.157	0.125	#NUM!	0.691	#VALUE!	0.065	0.962	0.088	0.100	0.090	0.088
τ	6.518	5.751	4.792	9.138	#VALUE!	#NUM!	#VALUE!	#VALUE!	9.928	#VALUE!	6.084	#VALUE!	6.841	7.321
Sdc	4.35E+08	4.03E+08	4.05E+08	3.98E+08	4.20E+08	#NUM!	1.25E+08	#VALUE!	4.20E+08	1.49E+07	4.21E+08	4.10E+08	4.19E+08	4.28E+08
NEP _{johnson}	1.188	1.187	1.287	1.210	1.157	#NUM!	0.175	#VALUE!	1.010	53.616	1.100	1.112	1.099	1.125
NEP _{photon}	2.129	2.065	2.212	2.085	2.063	#NUM!	0.059	#VALUE!	1.799	17.562	1.970	1.966	1.973	2.002
NEP _{load}	0.116	0.131	0.171	0.143	0.114	#NUM!	0.002	#VALUE!	0.049	40.940	0.076	0.085	0.078	0.082
NEP _{amp}	2.299	2.484	2.472	2.512	2.383	#NUM!	7.971	#VALUE!	2.379	67.282	2.375	2.438	2.385	2.337
NEP _{det}	4.237	4.411	4.525	4.465	4.280	#NUM!	11.276	#VALUE!	4.075	135.881	4.195	4.272	4.207	4.181
DQE	0.000	0.000	0.000	0.000	0.000	#NUM!	0.000	#VALUE!	0.000	0.000	0.000	0.000	0.000	0.000
Vn(det)	18.4	17.8	18.3	17.8	18.0	#NUM!	14.1	#VALUE!	17.1	20.2	17.7	17.5	17.6	17.9
Vn(total)	18.4	17.8	18.3	17.8	18.0	#NUM!	14.1	#VALUE!	17.1	20.2	17.7	17.5	17.6	17.9
Vn(calculated)														
Vn(measured) at 1Hz	28.5	22.3	26.0	31.5	25.7	10.5	10.2	26.0	23.4	48.5	36.1	22.7	20.4	22.4
NEP(measured) at 1 Hz	6.6	5.5	6.4	7.9	6.1	N/M	N/M	N/M	5.6	N/M	8.6	5.5	4.9	5.2
Vn(measured) at 0.1 Hz	30.4	23.9	28.5	31.6	27.2	10.6	10.0	27.4	25.5	51.0	38.0	24.1	21.8	24.1
NEP(measured) at 0.1 H	7.0	5.9	7.0	7.9	6.5	N/M	N/M	N/M	6.1	N/M	9.0	5.9	5.2	5.6
Vn(measured) at 1Hz no	42.4	39.7	38.3	37.5	40.4	10.1	9.9	31.5	24.0	36.1	35.3	37.2	37.8	36.8
NEP(measured) at 1Hz r	9.8	9.9	9.5	9.4	9.6	N/M	7.9	N/M	5.7	242.6	8.4	9.1	9.0	8.6
Vn(measured) at 0.1Hz r	55.2	77.8	53.6	59.0	70.0	10.2	10.7	103.5	37.0	36.8	43.2	45.5	48.7	44.2
NEP(measured) at 0.1Hz	12.7	19.3	13.2	14.8	16.7	N/M	8.6	N/M	8.8	247.5	10.3	11.1	11.6	10.3
* Noise under these conc														
These data are provide														

Symbol	Value	Value	Value	Value	Value	Value	Value	Value	Value	Value	Value	Value	Value	Value
T0														
Vn														
Q														
NEP _{photon}														
Vbias														
	C12	B11	A11	E13	D11	C11	B10	A10	D10	B9	C10	C9	A9	B8
Pthermal	4.372	4.198	4.236	4.140	4.040	4.177	4.544	4.056	4.205	4.067	4.198	3.961	4.572	4.265
Pelec+Q	4.372	4.198	4.236	4.140	4.040	4.177	4.544	4.056	4.205	4.067	4.198	3.961	4.572	4.265
Tbolo	0.36976	0.36707	0.36761	0.36757	0.36448	0.36623	0.37133	0.36591	0.36767	0.36569	0.36683	0.36473	0.37290	0.36875
T/T0	1.233	1.224	1.225	1.225	1.215	1.221	1.238	1.220	1.226	1.219	1.223	1.216	1.243	1.229
Rbolo	4.03E+06	3.75E+06	3.86E+06	3.69E+06	3.56E+06	3.76E+06	4.38E+06	3.56E+06	3.83E+06	3.64E+06	3.82E+06	3.45E+06	4.39E+06	3.97E+06
Vbolo	4.20	3.97	4.04	3.91	3.79	3.97	4.46	3.80	4.01	3.85	4.00	3.70	4.48	4.11
Ibolo	1.04	1.06	1.05	1.06	1.07	1.05	1.02	1.07	1.05	1.06	1.05	1.07	1.02	1.04
A	-5.36	-5.32	-5.33	-5.29	-5.29	-5.33	-5.38	-5.38	-5.26	-5.36	-5.36	-5.28	-5.34	-5.35
C	0.79	0.71	0.81	0.85	0.72	0.82	0.92	0.64	0.65	0.90	0.67	0.70	0.83	0.79
G	74.5	73.7	74.0	71.9	73.4	74.3	75.6	72.8	73.4	73.1	74.2	71.7	74.8	73.4
Z/R	0.080	0.096	0.093	0.094	0.112	0.100	0.069	0.099	0.099	0.101	0.094	0.111	0.067	0.085
τ	7.012	6.350	7.219	7.786	6.516	7.290	8.066	5.791	5.832	8.069	5.952	6.407	7.331	7.133
Sdc	4.33E+08	4.18E+08	4.24E+08	4.19E+08	4.07E+08	4.18E+08	4.49E+08	4.13E+08	4.20E+08	4.16E+08	4.23E+08	4.05E+08	4.49E+08	4.32E+08
NEP _{johnson}	1.110	1.118	1.117	1.107	1.128	1.122	1.109	1.105	1.126	1.110	1.114	1.117	1.109	1.105
NEP _{photon}	2.009	1.996	2.000	1.976	1.987	2.001	2.031	1.976	1.992	1.981	2.000	1.965	2.022	1.994
NEP _{load}	0.074	0.085	0.083	0.082	0.096	0.088	0.067	0.084	0.088	0.087	0.084	0.093	0.065	0.077
NEP _{amp}	2.311	2.394	2.359	2.389	2.457	2.394	2.229	2.422	2.379	2.404	2.367	2.467	2.228	2.313
NEP _{det}	4.146	4.238	4.200	4.217	4.311	4.242	4.065	4.254	4.224	4.238	4.207	4.306	4.060	4.139
DQE	0.000	0.000	0.000	0.000	0.000	0.000	0.000	0.000	0.000	0.000	0.000	0.000	0.000	0.000
Vn(det)	17.9	17.7	17.8	17.7	17.5	17.7	18.2	17.6	17.8	17.6	17.8	17.5	18.2	17.9
Vn(total)	17.9	17.7	17.8	17.7	17.5	17.7	18.2	17.6	17.8	17.6	17.8	17.5	18.2	17.9
Vn(calculated)														
Vn(measured) at 1Hz	21.5	28.3	22.6	22.6	22.0	20.4	22.3	19.6	20.4	20.8	25.9	> 40.0	20.9	20.2
NEP(measured) at 1 Hz	5.0	6.8	5.3	5.4	5.4	4.9	5.0	4.8	4.8	5.0	6.1	> 9.9	4.7	4.7
Vn(measured) at 0.1 Hz	22.7	42.7	24.8	23.7	23.5	22.3	24.7	21.6	23.0	22.4	27.8	> 40.0	22.2	22.3
NEP(measured) at 0.1 H	5.3	10.2	5.9	5.7	5.8	5.3	5.5	5.2	5.5	5.4	6.6	> 9.9	4.9	5.2
Vn(measured) at 1Hz no	37.3	43.9	38.2	33.7	35.4	35.4	38.6	37.2	35.4	40.7	38.4	38.2	134.4	37.7
NEP(measured) at 1Hz r	8.6	10.5	9.0	8.1	8.7	8.5	8.6	9.0	8.4	9.8	9.1	9.4	29.9	8.7
Vn(measured) at 0.1Hz r	46.3	80.0	56.7	39.4	45.0	54.5	53.7	49.4	45.2	55.4	48.3	50.4	136.1	47.5
NEP(measured) at 0.1Hz	10.7	19.1	13.4	9.4	11.0	13.0	12.0	12.0	10.7	13.3	11.4	12.4	30.3	11.0
* Noise under these conc														
These data are provide														

Symbol	Value	Value	Value	Value	Value	Value	Value	Value	Value	Value	Value	Value	Value	Value
T0														
Vn														
Q														
NEP _{photon}														
Vbias														
	A8	C8	C8	B7	R1	G1	T2	E1	D1	F1	E2	G2	F2	G3
Pthermal	3.955	4.421	3.952	3.942	#VALUE!	4.393	13.800	4.341	4.211	4.396	4.394	4.252	4.354	4.311
Pelec+Q	3.955	4.421	3.952	3.942	#VALUE!	4.393	6.990	4.341	4.211	4.396	4.394	4.252	4.354	4.311
Tbolo	0.36605	0.37105	0.36523	0.36578	#VALUE!	0.36599	0.30251	0.36588	0.36309	0.36588	0.36630	0.36458	0.35747	0.35771
T/T0	1.220	1.237	1.217	1.219	#VALUE!	1.220	1.008	1.220	1.210	1.220	1.221	1.215	1.192	1.192
Rbolo	3.45E+06	4.10E+06	3.52E+06	3.41E+06	#VALUE!	3.72E+06	1.17E+07	3.66E+06	3.51E+06	3.71E+06	3.73E+06	3.60E+06	3.70E+06	3.66E+06
Vbolo	3.70	4.26	3.73	3.66	#VALUE!	4.04	9.03	3.98	3.84	4.04	4.05	3.91	4.01	3.97
Ibolo	1.07	1.04	1.06	1.08	#VALUE!	1.09	0.77	1.09	1.10	1.09	1.09	1.09	1.09	1.09
A	-5.37	-5.39	-5.31	-5.33	#VALUE!	-5.27	-5.84	-5.31	-5.34	-5.32	-5.27	-5.33	-5.42	-5.39
C	0.76	0.76	0.70	0.68	#VALUE!	1.18	#VALUE!	0.76	0.62	0.66	0.65	0.88	0.76	1.35
G	70.8	74.0	71.5	70.6	#VALUE!	77.6	5640.2	77.0	77.8	78.1	77.6	76.7	87.3	86.0
Z/R	0.099	0.071	0.109	0.103	#VALUE!	0.102	0.953	0.100	0.113	0.099	0.102	0.105	0.139	0.139
τ	6.966	6.752	6.407	6.262	#VALUE!	10.147	#VALUE!	6.500	5.273	5.597	5.589	7.551	5.944	10.651
Sdc	4.12E+08	4.40E+08	4.11E+08	4.08E+08	#VALUE!	4.03E+08	1.77E+07	4.04E+08	3.95E+08	4.04E+08	4.04E+08	4.02E+08	3.84E+08	3.84E+08
NEP _{Johnson}	1.091	1.096	1.110	1.097	#VALUE!	1.156	45.151	1.145	1.153	1.150	1.156	1.142	1.226	1.222
NEP _{photon}	1.950	2.007	1.958	1.949	#VALUE!	2.052	16.609	2.042	2.045	2.055	2.050	2.036	2.155	2.140
NEP _{load}	0.082	0.065	0.091	0.085	#VALUE!	0.094	37.793	0.091	0.100	0.091	0.094	0.094	0.133	0.131
NEP _{amp}	2.426	2.274	2.434	2.449	#VALUE!	2.479	56.560	2.478	2.532	2.473	2.475	2.488	2.602	2.604
NEP _{det}	4.239	4.096	4.263	4.268	#VALUE!	4.381	116.652	4.369	4.437	4.372	4.375	4.376	4.608	4.600
DQE	0.000	0.000	0.000	0.000	#VALUE!	0.000	0.000	0.000	0.000	0.000	0.000	0.000	0.000	0.000
Vn(det)	17.5	18.0	17.5	17.4	#VALUE!	17.7	20.6	17.6	17.5	17.7	17.7	17.6	17.7	17.7
Vn(total)	17.5	18.0	17.5	17.4	#VALUE!	17.7	20.6	17.6	17.5	17.7	17.7	17.6	17.7	17.7
Vn(calculated)														
Vn(measured) at 1Hz	21.6	21.3	19.4	21.9	22.4	22.6	47.6	35.6	21.7	> 40	21.5	30.9	20.7	22.9
NEP(measured) at 1 Hz	5.2	4.8	4.7	5.4	N/M	5.6	N/M	8.8	5.5	> 9.9	5.3	7.7	5.4	6.0
Vn(measured) at 0.1 Hz	22.7	23.7	20.8	24.1	22.2	24.8	49.1	37.2	22.2	> 40.0	22.9	32.0	22.8	24.5
NEP(measured) at 0.1 H	5.5	5.4	5.1	5.9	N/M	6.1	N/M	9.2	5.6	> 9.9	5.7	7.9	5.9	6.4
Vn(measured) at 1Hz no	38.9	34.8	31.5	30.9	29.8	0.0	35.6	34.2	31.9	44.3	86.7	34.8	32.9	32.1
NEP(measured) at 1Hz r	9.4	7.9	7.7	7.6	N/M	0.0	201.1	8.5	8.1	11.0	21.5	8.6	8.6	8.4
Vn(measured) at 0.1Hz r	51.2	39.9	39.0	42.4	49.1	0.0	36.4	38.8	35.2	49.1	85.8	39.7	46.5	51.5
NEP(measured) at 0.1Hz	12.4	9.1	9.5	10.4	N/M	0.0	205.7	9.6	8.9	12.1	21.2	9.9	12.1	13.4
* Noise under these conc														
These data are provide														

Symbol	Value	Value	Value	Value	Value	Value	Value	Value	Value	Value	Value	Value	Value	Value
T0														
Vn														
Q														
NEP _{photon}														
Vbias														
	E3	D3	F3	G4	E4	F4	E5	D5	F5	G5	E6	G6	F6	G7
Pthermal	4.238	4.546	4.373	4.343	4.524	4.118	4.026	4.306	4.216	4.376	4.087	4.190	4.365	4.191
Pelec+Q	4.238	4.546	4.373	4.343	4.524	4.118	4.026	4.306	4.216	4.376	4.087	4.190	4.365	4.191
Tbolo	0.35731	0.36043	0.35766	0.35819	0.36008	0.35621	0.35601	0.35867	0.35786	0.35939	0.35580	0.35872	0.36112	0.36020
T/T0	1.191	1.201	1.192	1.194	1.200	1.187	1.187	1.196	1.193	1.198	1.186	1.196	1.204	1.201
Rbolo	3.59E+06	4.00E+06	3.80E+06	3.87E+06	4.04E+06	3.52E+06	3.44E+06	3.71E+06	3.65E+06	3.91E+06	3.41E+06	3.59E+06	3.84E+06	3.61E+06
Vbolo	3.90	4.26	4.08	4.10	4.28	3.81	3.72	4.00	3.92	4.14	3.73	3.88	4.10	3.89
Ibolo	1.09	1.07	1.07	1.06	1.06	1.08	1.08	1.08	1.07	1.06	1.09	1.08	1.07	1.08
A	-5.37	-5.35	-5.39	-5.40	-5.41	-5.44	-5.45	-5.41	-5.44	-5.34	-5.40	-5.37	-5.44	-5.35
C	0.73	0.70	0.74	0.69	0.72	0.69	0.70	0.68	0.77	0.86	0.73	0.85	0.72	0.79
G	85.1	87.5	87.4	85.9	87.2	84.4	83.0	85.1	84.4	85.1	84.4	82.6	83.2	80.8
Z/R	0.144	0.129	0.140	0.135	0.123	0.146	0.148	0.135	0.137	0.134	0.153	0.136	0.117	0.130
τ	5.787	5.506	5.802	5.507	5.610	5.503	5.691	5.382	6.138	6.896	5.875	6.939	5.786	6.571
Sdc	3.82E+08	3.95E+08	3.88E+08	3.95E+08	4.02E+08	3.83E+08	3.82E+08	3.90E+08	3.90E+08	3.96E+08	3.75E+08	3.88E+08	4.03E+08	3.92E+08
NEP _{johnson}	1.221	1.233	1.232	1.216	1.215	1.207	1.197	1.210	1.202	1.220	1.220	1.198	1.181	1.185
NEP _{photon}	2.128	2.161	2.157	2.141	2.159	2.114	2.094	2.127	2.116	2.133	2.113	2.097	2.108	2.077
NEP _{load}	0.133	0.129	0.135	0.130	0.122	0.132	0.130	0.127	0.126	0.130	0.138	0.124	0.111	0.118
NEP _{amp}	2.620	2.530	2.579	2.529	2.488	2.613	2.617	2.567	2.567	2.523	2.670	2.577	2.483	2.549
NEP _{det}	4.612	4.533	4.586	4.513	4.475	4.591	4.581	4.546	4.536	4.504	4.662	4.536	4.425	4.488
DQE	0.000	0.000	0.000	0.000	0.000	0.000	0.000	0.000	0.000	0.000	0.000	0.000	0.000	0.000
Vn(det)	17.6	17.9	17.8	17.8	18.0	17.6	17.5	17.7	17.7	17.9	17.5	17.6	17.8	17.6
Vn(total)	17.6	17.9	17.8	17.8	18.0	17.6	17.5	17.7	17.7	17.9	17.5	17.6	17.8	17.6
Vn(calculated)														
Vn(measured) at 1Hz	20.5	21.9	20.7	20.6	28.1	19.6	> 40.0	20.5	21.7	21.4	22.0	22.6	20.0	22.4
NEP(measured) at 1 Hz	5.4	5.5	5.3	5.2	7.0	5.1	> 10.5	5.3	5.6	5.4	5.9	5.8	5.0	5.7
Vn(measured) at 0.1 Hz	22.3	24.5	22.6	22.2	29.0	21.2	> 40.0	21.6	23.2	23.1	22.8	25.2	21.4	23.3
NEP(measured) at 0.1 H	5.9	6.2	5.8	5.6	7.2	5.6	> 10.5	5.6	5.9	5.8	6.1	6.5	5.3	5.9
Vn(measured) at 1Hz no	30.6	43.3	32.7	31.6	32.1	66.7	44.1	44.1	32.6	35.0	45.7	43.1	131.1	126.8
NEP(measured) at 1Hz r	8.0	10.9	8.4	8.0	8.0	17.4	11.5	11.3	8.4	8.8	12.2	11.1	32.5	32.3
Vn(measured) at 0.1Hz r	41.4	49.4	38.7	37.7	38.5	73.5	51.0	56.1	56.7	69.6	69.4	66.1	143.7	131.7
NEP(measured) at 0.1Hz	10.8	12.5	10.0	9.5	9.6	19.2	13.4	14.4	14.5	17.6	18.5	17.0	35.7	33.6
* Noise under these conc														
These data are provide														

Symbol	Parameter	Equation (or Comments)
T0		
Vn		
Q		
NEP _{photon}		
Vbias		
Pthermal	Power as function of Temperature	$P_{thermal} = [G300/(1+\beta)][T/0.3]^{\beta}T$ evaluated from To to Tb
Pelec+Q	Electrical + Absorbed Power	$P_e + Q = [V_{bias}/(2R_L + R_B)]^2 R_B + Q$
Tbolo	Bolometer Temperature	Solve for Tb using Newtonian recursion such that $P_{thermal} = P_e + Q$
T/T0		$T/T_0 = T_{bolo}/T_0$
Rbolo	Bolometer Resistance	$R_{bolo} = (R_0) \exp[(\Delta/Tb)^{1/2}]$
Vbolo	Voltage across Bolometer	$V_{bolo} = [V_{bias}/(2R_L + R_B)]R_B$
Ibolo	Current through Bolometer	$I_{bolo} = V_{bias}/(2R_L + R_B)$
A		$A = (T/R)(dR/dT) = -(1/2)[(\Delta/Tb)^{1/2}]$
C	Dynamic Heat Capacity	$C = C300[(T/0.3)^{\gamma}]$
G	Dynamic Thermal Conductance	$G = G300[(T/0.3)^{\beta}]$
Z/R		$Z/R = (I/V)(dV/dI) = [-1 - GTb/(P_e A)] / [1 - GTb/(P_e A)]$
τ	Electrical Time Constant	$\tau = [C/2G][Z/R + 1](1 + 2R_L/R_B) / [Z/R + 2R_L/R_B]$
Sdc	Electrical Responsivity at 0 Hz	$S_{dc} = (1/2)[R_B/P_e]^{1/2} [1 - Z/R] / [1 + (Z/R)(R_B/2R_L)]$
NEP _{johnson}	Johnson Noise Prior to Demodulation	$NEP_{johnson} = [(4k(Tb)^3 G^2)/(P_e A^2)]^{1/2}$
NEP _{phonon}	Phonon Noise Prior to Demodulation	$= \{ [(4kTo^2 G)(\beta+1)((T/To)^{2\beta+3}-1)] / [(2\beta+3)(T/To)^{\beta}((T/To)^{\beta+1}-1)] \}^{1/2}$
NEP _{load}	Johnson Noise from R _L Prior to Demod.	$NEP_{load} = [4kTo/2R_L]^{1/2} 2(Z/R)R_B I_{bolo} / [(Z/R) - 1] $
NEP _{amp}	Amplifier Noise Prior to Demodulation	$NEP_{amp} = Vn / S_{dc}$
NEP _{det}	Detector Noise after Demodulation	$NEP_{det} = [2NEP_{john}^2 + NEP_{phon}^2 + 2NEP_{load}^2 + 2NEP_{amp}^2]^{1/2}$
DQE	BLIP Figure-of-Merit for Detector	$DQE = NEP_{photon}^2 / (NEP_{photon}^2 + NEP_{det}^2)$
Vn(det)	Voltage Noise of Detector After Demod.	$Vn(det) = NEP_{det} S_{dc}$
Vn(total)	Total Noise after Demodulation	$Vn(total) = [NEP_{det}^2 + NEP_{photon}^2]^{1/2} S_{dc}$
Vn(calculated)		
Vn(measured) at 1Hz		
NEP(measured) at 1 Hz		
Vn(measured) at 0.1 Hz		
NEP(measured) at 0.1 H		
Vn(measured) at 1Hz no		
NEP(measured) at 1Hz r		
Vn(measured) at 0.1Hz r		
NEP(measured) at 0.1Hz		
* Noise under these conc		
These data are provide		

Symbol	Units	Value	Value	Value	Value	Value	Value	Value	Value	Value	Value	Value	Value	Value	Value	Value
T0	K	0.3	Base Temperature													
Vn	nV/rtHz	10	Amplifier Voltage Noise													
Q	pW	3.3	Absorbed Power Onto Bolometer													
NEP _{photon}	1e-17 W/rtHz	6.30	Noise in Absorbed Optical Power													
Vbias	mV	18.5	Bias Across Bolometer & Load Resistors													
			Detector ID													
		Target	A7	A6	B6	C7	A5	B5	C6	D6	B4	C5	D4	A4	C4	B3
Pthermal	pW	6.163	5.705	5.745	5.671	5.574	5.788	5.700	5.789	5.676	5.806	6.014	5.929	5.628	5.774	5.761
Pelec+Q	pW	6.163	5.705	5.745	5.671	5.574	5.788	5.700	5.789	5.676	5.806	6.014	5.929	5.628	5.774	5.761
Tbolo	K	0.39339	0.37963	0.37997	0.37831	0.37686	0.37840	0.37765	0.37831	0.37716	0.38791	0.39035	0.38739	0.38588	0.38489	0.38435
T/T0		1.311	1.265	1.267	1.261	1.256	1.261	1.259	1.261	1.257	1.293	1.301	1.291	1.286	1.283	1.281
Rbolo	Ω	5.39E+06	2.71E+06	2.63E+06	2.66E+06	2.56E+06	2.84E+06	2.75E+06	2.89E+06	2.76E+06	2.99E+06	3.29E+06	3.24E+06	2.72E+06	2.92E+06	2.96E+06
Vbolo	mV	3.93	2.55	2.54	2.51	2.41	2.66	2.57	2.68	2.56	2.74	2.99	2.92	2.52	2.69	2.70
Ibolo	nA	0.73	0.94	0.96	0.94	0.94	0.94	0.94	0.93	0.93	0.92	0.91	0.90	0.92	0.92	0.91
A		-5.15	-5.26	-5.24	-5.28	-5.27	-5.31	-5.16	-5.27	-5.31	-5.20	-5.21	-5.25	-5.20	-5.26	-5.22
C	pJ/K	1.31	0.87	0.93	0.97	0.78	0.93	0.75	0.83	0.74	0.78	0.74	0.67	0.87	0.69	0.94
G	pW/K	79.6	86.8	87.0	87.9	87.5	89.3	88.0	89.7	88.8	81.5	82.0	83.2	80.3	83.5	83.4
Z/R		0.359	0.445	0.442	0.453	0.467	0.438	0.457	0.442	0.453	0.416	0.387	0.400	0.438	0.423	0.428
τ	ms	4.000	7.848	8.310	8.689	6.995	8.123	6.686	7.237	6.589	7.426	6.960	6.195	8.455	6.435	8.799
Sdc	V/K	4.01E+08	2.75E+08	2.71E+08	2.71E+08	2.65E+08	2.80E+08	2.71E+08	2.80E+08	2.75E+08	2.97E+08	3.14E+08	3.10E+08	2.84E+08	2.92E+08	2.92E+08
NEP _{johnson}	1e-17 W/rtHz	1.673	1.848	1.848	1.868	1.891	1.845	1.897	1.863	1.868	1.777	1.731	1.750	1.803	1.790	1.803
NEP _{phonon}	1e-17 W/rtHz	2.150	2.191	2.195	2.198	2.192	2.219	2.207	2.221	2.209	2.140	2.157	2.164	2.122	2.158	2.159
NEP _{load}	1e-17 W/rtHz	0.401	0.405	0.401	0.411	0.416	0.410	0.426	0.419	0.416	0.383	0.372	0.381	0.384	0.388	0.394
NEP _{amp}	1e-17 W/rtHz	2.495	3.638	3.694	3.695	3.779	3.578	3.696	3.576	3.641	3.362	3.185	3.228	3.521	3.422	3.422
NEP _{det}	1e-17 W/rtHz	4.795	6.200	6.266	6.281	6.393	6.137	6.305	6.147	6.222	5.814	5.587	5.652	6.008	5.898	5.907
DQE		0.633	0.508	0.503	0.502	0.493	0.513	0.500	0.512	0.506	0.540	0.560	0.554	0.524	0.533	0.532
Vn(det)	nV/rtHz	19.2	17.0	17.0	17.0	16.9	17.2	17.1	17.2	17.1	17.3	17.5	17.5	17.1	17.2	17.3
Vn(total)	nV/rtHz	31.7	24.3	24.1	24.1	23.7	24.6	24.1	24.6	24.3	25.5	26.4	26.2	24.7	25.2	25.2
Measured																
Q _{incident}	1.16E-11															
NEP _{photon}	9.69E-17															
Q _{absorbed}			N/M	N/M	8.118E-12	N/A	8.827E-12	7.79E-12	7.941E-12	8.171E-12	7.973E-12	7.934E-12	8.256E-12	9.194E-12	8.059E-12	8.161E-12
NEP _{photon}			N/M	N/M	8.099E-17	N/A	8.445E-17	7.934E-17	8.01E-17	8.125E-17	8.026E-17	8.007E-17	8.168E-17	8.619E-17	8.069E-17	8.12E-17
Vn(total, gain = 57300)			0.0012333	0.0020814	0.0013961	N/A	0.0016456	0.0015933	0.001589	0.0014673	0.0015614	0.0017511	0.0016302	0.0019089	0.0016721	0.0018064
Vn(total)		2.8585E-08	1.52195E-08	3.632E-08	2.436E-08	N/A	2.872E-08	2.781E-08	2.773E-08	2.561E-08	2.725E-08	3.056E-08	2.845E-08	3.331E-08	2.918E-08	3.153E-08
Sdc			N/M	N/M	1.62E+08	N/A	1.81E+08	1.68E+08	1.69E+08	1.64E+08	1.75E+08	2.18E+08	1.78E+08	2.05E+08	1.72E+08	2.03E+08
NEP(total)					1.501E-16	N/A	1.588E-16	1.656E-16	1.644E-16	1.559E-16	1.555E-16	1.399E-16	1.603E-16	1.625E-16	1.698E-16	1.549E-16
DQE		#VALUE!	N/M	N/M	0.29	N/A	0.28	0.23	0.24	0.27	0.27	0.33	0.26	0.28	0.23	0.27

Symbol	Value	Value	Value	Value	Value	Value	Value	Value	Value	Value	Value	Value	Value	Value	Value	Value	Value
T0																	
Vn																	
Q																	
NEP _{photon}																	
Vbias																	
	G9	D9	F9	E10	G10	F10	E11	G11	F11	E12	G12	F12	G13	DK2	SH	SH	R2
Pthermal	5.814	6.111	5.862	5.838	5.600	5.868	5.892	5.743	5.716	6.158	5.756	6.115	5.758	5.837	#NUM!	50.863	#VALUE!
Pelec+Q	5.814	6.111	5.862	5.838	5.600	5.868	5.892	5.743	5.716	6.158	5.756	6.115	5.758	5.837	#NUM!	3.301	#VALUE!
Tbolo	0.37737	0.37996	0.37768	0.37651	0.37556	0.37692	0.37751	0.37641	0.37593	0.38033	0.37805	0.37203	0.37624	0.38012	#NUM!	10.04650	#VALUE!
T/T0	1.258	1.267	1.259	1.255	1.252	1.256	1.258	1.255	1.253	1.268	1.260	1.240	1.254	1.267	#NUM!	33.488	#VALUE!
Rbolo	2.81E+06	3.23E+06	2.84E+06	2.89E+06	2.46E+06	2.89E+06	2.97E+06	2.69E+06	2.68E+06	3.47E+06	2.77E+06	3.42E+06	2.80E+06	2.93E+06	#NUM!	6.83E+02	#VALUE!
Vbolo	2.66	3.01	2.70	2.71	2.38	2.73	2.77	2.57	2.54	3.15	2.61	3.10	2.62	2.73	#NUM!	0.00	#VALUE!
Ibolo	0.95	0.93	0.95	0.94	0.97	0.94	0.93	0.95	0.95	0.91	0.94	0.91	0.94	0.93	#NUM!	1.07	#VALUE!
A	-5.25	-5.28	-5.23	-5.28	-5.22	-5.26	-5.28	-5.26	-5.23	-5.31	-5.23	-5.27	-5.19	-5.31	#NUM!	-0.19	#VALUE!
C	0.77	0.88	0.68	0.74	0.90	0.74	#VALUE!	0.69	0.84	0.85	0.72	0.66	1.16	#VALUE!	#VALUE!	#VALUE!	#VALUE!
G	90.2	92.0	91.3	92.1	88.8	91.9	91.7	89.9	89.9	92.7	88.7	101.3	90.0	88.0	#NUM!	13.5	#VALUE!
Z/R	0.441	0.404	0.440	0.442	0.471	0.439	0.433	0.450	0.456	0.398	0.446	0.435	0.452	0.426	#NUM!	1.000	#VALUE!
τ	6.710	7.469	5.861	6.281	8.032	6.326	#VALUE!	6.021	7.389	7.114	6.377	5.190	10.127	#VALUE!	#NUM!	#VALUE!	#VALUE!
Sdc	2.75E+08	2.96E+08	2.74E+08	2.76E+08	2.56E+08	2.77E+08	2.82E+08	2.69E+08	2.67E+08	3.06E+08	2.74E+08	2.86E+08	2.72E+08	2.88E+08	#NUM!	1.01E+03	#VALUE!
NEP _{johnson}	1.865	1.808	1.879	1.879	1.918	1.875	1.858	1.878	1.894	1.799	1.869	1.931	1.895	1.812	#NUM!	61014.190	#VALUE!
NEP _{phonon}	2.232	2.262	2.240	2.248	2.209	2.248	2.247	2.228	2.227	2.268	2.214	2.349	2.231	2.210	#NUM!	17.795	#VALUE!
NEP _{load}	0.417	0.408	0.422	0.426	0.421	0.424	0.421	0.418	0.423	0.412	0.416	0.472	0.429	0.400	#NUM!	66.404	#VALUE!
NEP _{amp}	3.636	3.376	3.648	3.619	3.910	3.614	3.549	3.714	3.744	3.263	3.648	3.496	3.676	3.478	#NUM!	#####	#VALUE!
NEP _{det}	6.223	5.897	6.249	6.219	6.570	6.210	6.124	6.321	6.366	5.766	6.233	6.153	6.289	5.997	#NUM!	#####	#VALUE!
DQE	0.506	0.533	0.504	0.506	0.479	0.507	0.514	0.498	0.495	0.544	0.505	0.512	0.501	0.525	#NUM!	0.000	#VALUE!
Vn(det)	17.1	17.5	17.1	17.2	16.8	17.2	17.3	17.0	17.0	17.7	17.1	17.6	17.1	17.2	#NUM!	14.2	#VALUE!
Vn(total)	24.4	25.6	24.3	24.5	23.3	24.5	24.8	24.0	23.9	26.2	24.3	25.2	24.2	25.0	#NUM!	14.2	#VALUE!
Measured																	
Q _{incident}																	
NEP _{photon}																	
Q _{absorbed}	#VALUE!	7.839E-12	8.549E-12	8.167E-12	8.78E-12	8.167E-12	8.917E-12	#VALUE!	#VALUE!	#VALUE!							
NEP _{photon}	#VALUE!	7.958E-17	8.311E-17	8.123E-17	8.423E-17	8.123E-17	8.488E-17	#VALUE!	#VALUE!	#VALUE!							
Vn(total, gain)	0.0024331	0.0024331	0.0024331	0.0024331	0.0024331	0.0024331	0.0024331	0.0024331	0.0024331	0.0024331	0.0024331	0.0024331	0.0024331	0.0024331			
Vn(total)	4.246E-08	4.246E-08	4.246E-08	4.246E-08	4.246E-08	4.246E-08	4.246E-08	4.246E-08	4.246E-08	4.246E-08	4.246E-08	4.246E-08	4.246E-08	4.246E-08			
Sdc	1.75E+08	1.75E+08	1.75E+08	1.75E+08	1.75E+08	1.75E+08	1.75E+08	1.75E+08	1.75E+08	1.75E+08	1.75E+08	1.75E+08	1.75E+08	1.75E+08			
NEP(total)	2.424E-16	2.424E-16	2.424E-16	2.424E-16	2.424E-16	2.424E-16	2.424E-16	2.424E-16	2.424E-16	2.424E-16	2.424E-16	2.424E-16	2.424E-16	2.424E-16			
DQE	#VALUE!	0.11	0.12	0.11	0.12	0.11	0.12	#VALUE!	#VALUE!	#VALUE!							

Symbol	Value	Value	Value	Value	Value	Value	Value	Value	Value	Value	Value	Value	Value	Value	Value	Value	Value	Value
T0																		
Vn																		
Q																		
NEP _{photon}																		
Vbias																		
	A13	T1	B12	C13	A12	D12	C12	B11	A11	E13	D11	C11	B10	A10	D10	B9	C10	
Pthermal	5.514	26.233	5.879	5.810	5.858	6.034	6.046	5.906	5.938	5.855	5.784	5.892	6.190	5.787	5.917	5.799	5.907	
Pelec+Q	5.514	8.275	5.879	5.810	5.858	6.034	6.046	5.906	5.938	5.855	5.784	5.892	6.190	5.787	5.917	5.799	5.907	
Tbolo	0.40519	0.30427	0.39163	0.39021	0.39068	0.39160	0.39111	0.38909	0.38946	0.39022	0.38699	0.38815	0.39208	0.38843	0.38983	0.38815	0.38870	
T/T0	1.351	1.014	1.305	1.301	1.302	1.305	1.304	1.297	1.298	1.301	1.290	1.294	1.307	1.295	1.299	1.294	1.296	
Rbolo	2.18E+06	9.91E+06	2.71E+06	2.59E+06	2.68E+06	2.98E+06	2.99E+06	2.76E+06	2.85E+06	2.70E+06	2.60E+06	2.77E+06	3.29E+06	2.59E+06	2.83E+06	2.66E+06	2.81E+06	
Vbolo	2.20	7.02	2.64	2.55	2.62	2.85	2.87	2.68	2.74	2.63	2.54	2.68	3.08	2.54	2.72	2.58	2.71	
Ibolo	1.01	0.71	0.98	0.98	0.98	0.96	0.96	0.97	0.96	0.97	0.98	0.97	0.94	0.98	0.96	0.97	0.96	
A	-4.99	-5.81	-5.15	-5.11	-5.19	-5.10	-5.22	-5.16	-5.18	-5.13	-5.14	-5.18	-5.23	-5.22	-5.11	-5.21	-5.21	
C	1.00	#VALUE!	0.71	#VALUE!	0.80	0.86	0.84	0.75	0.86	0.91	0.77	0.87	0.97	0.68	0.68	0.95	0.71	
G	66.8	6432.8	79.4	79.5	80.1	81.3	82.3	81.5	81.9	79.5	81.5	82.2	83.0	81.0	81.2	81.2	82.1	
Z/R	0.420	0.971	0.401	0.415	0.404	0.391	0.384	0.404	0.400	0.406	0.424	0.408	0.366	0.416	0.406	0.416	0.403	
τ	11.415	#VALUE!	6.813	#VALUE!	7.657	8.130	7.778	7.092	8.037	8.740	7.295	8.128	8.905	6.484	6.494	9.021	6.632	
Sdc	2.72E+08	1.29E+07	2.88E+08	2.79E+08	2.86E+08	2.97E+08	3.00E+08	2.87E+08	2.92E+08	2.86E+08	2.76E+08	2.86E+08	3.15E+08	2.80E+08	2.88E+08	2.82E+08	2.90E+08	
NEP _{johnson}	1.724	61.929	1.748	1.778	1.751	1.756	1.731	1.764	1.757	1.756	1.800	1.772	1.703	1.770	1.777	1.774	1.758	
NEP _{phonon}	1.974	17.596	2.123	2.121	2.128	2.151	2.158	2.147	2.151	2.127	2.141	2.152	2.174	2.133	2.144	2.137	2.151	
NEP _{load}	0.322	47.383	0.358	0.366	0.359	0.369	0.360	0.367	0.368	0.362	0.377	0.371	0.357	0.365	0.374	0.369	0.367	
NEP _{amp}	3.673	77.641	3.476	3.589	3.497	3.371	3.330	3.486	3.430	3.495	3.619	3.491	3.174	3.575	3.468	3.543	3.450	
NEP _{det}	6.085	156.610	5.919	6.071	5.948	5.813	5.753	5.950	5.882	5.948	6.127	5.963	5.561	6.053	5.937	6.020	5.906	
DQE	0.517	0.002	0.531	0.519	0.529	0.540	0.545	0.529	0.534	0.529	0.514	0.527	0.562	0.520	0.530	0.523	0.532	
Vn(det)	16.6	20.2	17.0	16.9	17.0	17.2	17.3	17.1	17.1	17.0	16.9	17.1	17.5	16.9	17.1	17.0	17.1	
Vn(total)	23.8	20.2	24.9	24.4	24.8	25.4	25.6	24.9	25.1	24.8	24.3	24.8	26.5	24.4	25.0	24.6	25.0	
Measured																		
Q _{incident}																		
NEP _{photon}																		
Q _{absorbed}																		
NEP _{photon}																		
Vn(total, gain)																		
Vn(total)																		
Sdc																		
NEP(total)																		
DQE																		

Symbol	Value	Value	Value	Value	Value	Value	Value	Value	Value	Value	Value	Value	Value	Value	Value	Value	Value	Value
T0																		
Vn																		
Q																		
NEP _{photon}																		
Vbias																		
	C9	A9	B8	A8	C8	C8	B7	R1	G1	T2	E1	D1	F1	E2	G2	F2	G3	
Pthermal	5.715	6.212	5.959	5.701	6.081	5.708	5.692	#VALUE!	6.071	15.384	6.025	5.924	6.071	6.073	5.953	6.067	6.030	
Pelec+Q	5.715	6.212	5.959	5.701	6.081	5.708	5.692	#VALUE!	6.071	8.619	6.025	5.924	6.071	6.073	5.953	6.067	6.030	
Tbolo	0.38789	0.39379	0.39066	0.38934	0.39238	0.38846	0.38919	#VALUE!	0.38664	0.30279	0.38674	0.38406	0.38636	0.38695	0.38574	0.37624	0.37683	
T/T0	1.293	1.313	1.302	1.298	1.308	1.295	1.297	#VALUE!	1.289	1.009	1.289	1.280	1.288	1.290	1.286	1.254	1.256	
Rbolo	2.51E+06	3.29E+06	2.93E+06	2.49E+06	3.05E+06	2.55E+06	2.46E+06	#VALUE!	2.79E+06	1.16E+07	2.74E+06	2.61E+06	2.79E+06	2.80E+06	2.67E+06	2.81E+06	2.77E+06	
Vbolo	2.46	3.10	2.79	2.45	2.91	2.48	2.43	#VALUE!	2.78	7.85	2.73	2.62	2.78	2.79	2.66	2.79	2.75	
Ibolo	0.98	0.94	0.95	0.98	0.96	0.97	0.99	#VALUE!	1.00	0.68	1.00	1.00	1.00	0.99	1.00	0.99	0.99	
A	-5.12	-5.19	-5.20	-5.21	-5.24	-5.15	-5.17	#VALUE!	-5.13	-5.84	-5.16	-5.20	-5.18	-5.13	-5.18	-5.28	-5.25	
C	0.74	0.87	0.84	0.80	0.80	0.74	0.72	#VALUE!	1.25	#VALUE!	0.80	0.65	0.70	0.69	0.93	0.80	1.42	
G	79.8	82.2	81.2	79.1	81.6	79.8	78.8	#VALUE!	84.9	5670.9	84.5	85.6	85.6	85.0	84.2	95.3	93.9	
Z/R	0.429	0.364	0.393	0.423	0.374	0.429	0.426	#VALUE!	0.396	0.964	0.398	0.414	0.394	0.396	0.406	0.421	0.423	
τ	7.201	8.086	7.940	7.832	7.498	7.181	7.052	#VALUE!	11.314	#VALUE!	7.257	5.892	6.234	6.221	8.449	6.558	11.776	
Sdc	2.73E+08	3.15E+08	2.98E+08	2.76E+08	3.06E+08	2.76E+08	2.74E+08	#VALUE!	2.83E+08	1.53E+07	2.82E+08	2.74E+08	2.84E+08	2.84E+08	2.79E+08	2.72E+08	2.71E+08	
NEP _{johnson}	1.800	1.704	1.738	1.771	1.705	1.797	1.779	#VALUE!	1.777	52.140	1.771	1.798	1.770	1.781	1.778	1.860	1.860	
NEP _{phonon}	2.121	2.167	2.145	2.110	2.154	2.118	2.108	#VALUE!	2.193	16.640	2.185	2.190	2.197	2.192	2.179	2.291	2.278	
NEP _{load}	0.372	0.356	0.362	0.361	0.351	0.373	0.362	#VALUE!	0.374	43.765	0.370	0.377	0.371	0.375	0.371	0.415	0.413	
NEP _{amp}	3.664	3.171	3.360	3.619	3.267	3.629	3.654	#VALUE!	3.529	65.258	3.544	3.653	3.522	3.527	3.581	3.681	3.696	
NEP _{det}	6.173	5.556	5.787	6.098	5.660	6.129	6.143	#VALUE!	6.026	134.395	6.036	6.184	6.014	6.026	6.082	6.294	6.307	
DQE	0.510	0.563	0.542	0.516	0.553	0.514	0.513	#VALUE!	0.522	0.002	0.521	0.509	0.523	0.522	0.518	0.500	0.499	
Vn(det)	16.8	17.5	17.2	16.8	17.3	16.9	16.8	#VALUE!	17.1	20.6	17.0	16.9	17.1	17.1	17.0	17.1	17.1	
Vn(total)	24.1	26.5	25.5	24.2	25.9	24.2	24.1	#VALUE!	24.7	20.6	24.6	24.2	24.7	24.7	24.5	24.2	24.1	
Measured																		
Q _{incident}																		
NEP _{photon}																		
Q _{absorbed}																		
NEP _{photon}																		
Vn(total, gain)																		
Vn(total)																		
Sdc																		
NEP(total)																		
DQE																		

Symbol	Value	Value	Value	Value	Value	Value	Value	Value	Value	Value	Value	Value	Value	Value
T0														
Vn														
Q														
NEP _{photon}														
Vbias														
	E3	D3	F3	G4	E4	F4	E5	D5	F5	G5	E6	G6	F6	G7
Pthermal	5.972	6.227	6.086	6.059	6.205	5.873	5.796	6.024	5.950	6.087	5.851	5.927	6.063	5.923
Pelec+Q	5.972	6.227	6.086	6.059	6.205	5.873	5.796	6.024	5.950	6.087	5.851	5.927	6.063	5.923
Tbolo	0.37677	0.37881	0.37640	0.37732	0.37856	0.37603	0.37630	0.37795	0.37745	0.37862	0.37570	0.37878	0.38059	0.38062
T/T0	1.256	1.263	1.255	1.258	1.262	1.253	1.254	1.260	1.258	1.262	1.252	1.263	1.269	1.269
Rbolo	2.71E+06	3.07E+06	2.89E+06	2.93E+06	3.10E+06	2.63E+06	2.55E+06	2.81E+06	2.74E+06	2.97E+06	2.55E+06	2.69E+06	2.90E+06	2.70E+06
Vbolo	2.69	3.00	2.84	2.84	3.00	2.60	2.53	2.77	2.70	2.88	2.55	2.66	2.83	2.66
Ibolo	0.99	0.98	0.98	0.97	0.97	0.99	0.99	0.99	0.98	0.97	1.00	0.99	0.98	0.99
A	-5.23	-5.22	-5.26	-5.26	-5.28	-5.30	-5.30	-5.27	-5.30	-5.20	-5.25	-5.23	-5.30	-5.21
C	0.76	0.74	0.78	0.73	0.75	0.72	0.74	0.71	0.81	0.91	0.77	0.90	0.75	0.83
G	93.1	95.5	95.4	93.6	94.9	92.7	91.6	93.2	92.7	92.9	92.9	90.7	91.3	88.9
Z/R	0.430	0.406	0.421	0.418	0.402	0.438	0.445	0.421	0.427	0.417	0.445	0.429	0.407	0.425
τ	6.407	6.029	6.386	6.076	6.161	6.100	6.315	5.939	6.783	7.595	6.509	7.691	6.388	7.294
Sdc	2.67E+08	2.82E+08	2.74E+08	2.79E+08	2.87E+08	2.65E+08	2.62E+08	2.73E+08	2.71E+08	2.80E+08	2.59E+08	2.70E+08	2.83E+08	2.72E+08
NEP _{johnson}	1.870	1.852	1.866	1.847	1.825	1.870	1.875	1.852	1.853	1.853	1.895	1.854	1.808	1.839
NEP _{phonon}	2.267	2.297	2.294	2.277	2.293	2.258	2.242	2.267	2.259	2.270	2.258	2.240	2.249	2.222
NEP _{load}	0.414	0.419	0.420	0.414	0.409	0.412	0.410	0.410	0.409	0.416	0.418	0.406	0.395	0.399
NEP _{amp}	3.740	3.545	3.646	3.586	3.489	3.770	3.813	3.657	3.684	3.575	3.860	3.707	3.535	3.675
NEP _{det}	6.360	6.134	6.258	6.171	6.050	6.392	6.439	6.252	6.280	6.159	6.514	6.302	6.074	6.247
DQE	0.495	0.513	0.503	0.510	0.520	0.493	0.489	0.504	0.502	0.511	0.483	0.500	0.518	0.504
Vn(det)	17.0	17.3	17.2	17.2	17.3	17.0	16.9	17.1	17.0	17.2	16.9	17.0	17.2	17.0
Vn(total)	23.9	24.8	24.4	24.6	25.0	23.8	23.6	24.3	24.1	24.6	23.5	24.0	24.8	24.1
Measured														
Q _{incident}														
NEP _{photon}														
Q _{absorbed}														
NEP _{photon}														
Vn(total, gain)														
Vn(total)														
Sdc														
NEP(total)														
DQE														

Symbol	Parameter	Equation (or Comments)
T0		
Vn		
Q		
NEP _{photon}		
Vbias		
Pthermal	Power as function of Temperature	$P_{thermal} = [G300/(1+\beta)][T/0.3]^{\beta}T$ evaluated from To to Tb
Pelec+Q	Electrical + Absorbed Power	$P_e + Q = [V_{bias}/(2R_L + R_B)]^2 R_B + Q$
Tbolo	Bolometer Temperature	Solve for Tb using Newtonian recursion such that $P_{thermal} = P_e + Q$
T/T0		$T/T_0 = T_{bolo}/T_0$
Rbolo	Bolometer Resistance	$R_{bolo} = (R_0)\exp[(\Delta/Tb)^{1/2}]$
Vbolo	Voltage across Bolometer	$V_{bolo} = [V_{bias}/(2R_L + R_B)]R_B$
Ibolo	Current through Bolometer	$I_{bolo} = V_{bias}/(2R_L + R_B)$
A		$A = (T/R)(dR/dT) = -(1/2)[(\Delta/Tb)^{1/2}]$
C	Dynamic Heat Capacity	$C = C300[(T/0.3)^3]$
G	Dynamic Thermal Conductance	$G = G300[(T/0.3)^{\beta}]$
Z/R		$Z/R = (I/V)(dV/dI) = [-1 - GTb/(P_e A)] / [1 - GTb/(P_e A)]$
τ	Electrical Time Constant	$\tau = [C/2G][(Z/R + 1)(1 + 2R_L/R_B)] / [Z/R + 2R_L/R_B]$
Sdc	Electrical Responsivity at 0 Hz	$S_{dc} = (1/2)[R_B/P_e]^{1/2} [1 - Z/R] / [1 + (Z/R)(R_B/2R_L)]$
NEP _{johnson}	Johnson Noise Prior to Demodulation	$NEP_{johnson} = [(4k(Tb)^3 G^2)/(P_e A^2)]^{1/2}$
NEP _{phonon}	Phonon Noise Prior to Demodulation	$= \{[(4kT_0^2 G)(\beta+1)((T/T_0)^{2\beta+3}-1)]/[(2\beta+3)(T/T_0)^{\beta}((T/T_0)^{\beta+1}-1)]\}^{1/2}$
NEP _{load}	Johnson Noise from R _L Prior to Demod.	$NEP_{load} = [4kT_0/2R_L]^{1/2} [2(Z/R)R_B I_{bolo}/(Z/R) - 1]$
NEP _{amp}	Amplifier Noise Prior to Demodulation	$NEP_{amp} = V_n / S_{dc}$
NEP _{det}	Detector Noise after Demodulation	$NEP_{det} = [2NEP_{johnson}^2 + NEP_{phonon}^2 + 2NEP_{load}^2 + 2NEP_{amp}^2]^{1/2}$
DQE	BLIP Figure-of-Merit for Detector	$DQE = NEP_{photon}^2 / (NEP_{photon}^2 + NEP_{det}^2)$
Vn(det)	Voltage Noise of Detector After Demod.	$V_n(det) = NEP_{det} S_{dc}$
Vn(total)	Total Noise after Demodulation	$V_n(total) = [NEP_{det}^2 + NEP_{photon}^2]^{1/2} S_{dc}$
Measured		
Q _{incident}		
NEP _{photon}		
Q _{absorbed}		
NEP _{photon}		
Vn(total, gain)		
Vn(total)		
Sdc		
NEP(total)		
DQE		

EIDP Coverage For QM PLW BDA

Unit Identification							
Name	:	QM PLW BDA					
Part #	:	10209800 -8					
S/N	:	#007					

Environmental Testing							
	Axes Tested	Temperature	Duration or Number of Cycles	Pass/Fail	Requirement	Source	Waiver #
Random Vibration Test	X, Y, Z	100 K	2 min per axis	P	X, Y, Z at 90 K 1 min per axis	SSSD Sec # 3.4	HR-SP-JPL- RFW-006
High Level Sine Vibe Test	None	NA	NA	NA	X, Y, Z at 90 K	SSSD Sec # 3.4	HR-SP-JPL- RFW-005
Bakeout	NA	80 C	5 days as part of the assembly procedures	P	None (other than as part of the assembly procedure)	D-20549	
Thermal Cycles	NA	RoomT to ~ < 10 K	27	P	Min15 from RmT to < 77 K	D-20549	

Other Testing							
	Frequency (Hz)	Note	Minimum Performance	Source	Waiver #		
Lowest Resonant Frequency (X-axis)	283 Hz	Cold	> 200 Hz (Goal: >250 Hz)	SSSD Sec # 3.1.3	NA		
Lowest Resonant Frequency (Y-axis)	281 Hz	Cold	> 200 Hz (Goal: >250 Hz)	SSSD Sec # 3.1.3	NA		
Lowest Resonant Frequency (Z-axis)	276 Hz	Cold	> 200 Hz (Goal: >250 Hz)	SSSD Sec # 3.1.3	NA		
Metrology Measurements were performed before and after the Vibration Test and the Thermal Cycles							
	Motion in X/Y	Motion in Z	Meets Goal ?	Performance Goal	Source	Waiver #	
Maximum motion due to Random Vibration Test 1st axis (X)	21 µm	40 µm	Y	125 µm in X/Y and 500 µm in Z	SSSD Sec # 3.1.1	NA	
Maximum motion due to Random Vibration Test 2nd axis (Y)	22 µm	8.6 µm	Y	125 µm in X/Y and 500 µm in Z	SSSD Sec # 3.1.1	NA	
Maximum motion due to Random Vibration Test 3rd axis (Z)	9.5 µm	11 µm	Y	125 µm in X/Y and 500 µm in Z	SSSD Sec # 3.1.1	NA	
Cumulative Maximum motion	34 µm	56 µm	Y	125 µm in X/Y and 500 µm in Z	SSSD Sec # 3.1.1	NA	
Cold Continuity Measurements : In Process							
	Pass/Fail	Requirement	Source	Waiver #			
Cold Continuity Test (1st Thermal Cycle)	P	None	NA	NA			
Cold Continuity Test (2nd Thermal Cycle)	P	None	NA	NA			

QM BDA Random Vibration Test

P/N 10209800-8

S/N 007

X-axis Shake, Cold, Sine Surveys (Before and After 0 dB Random Vibe)

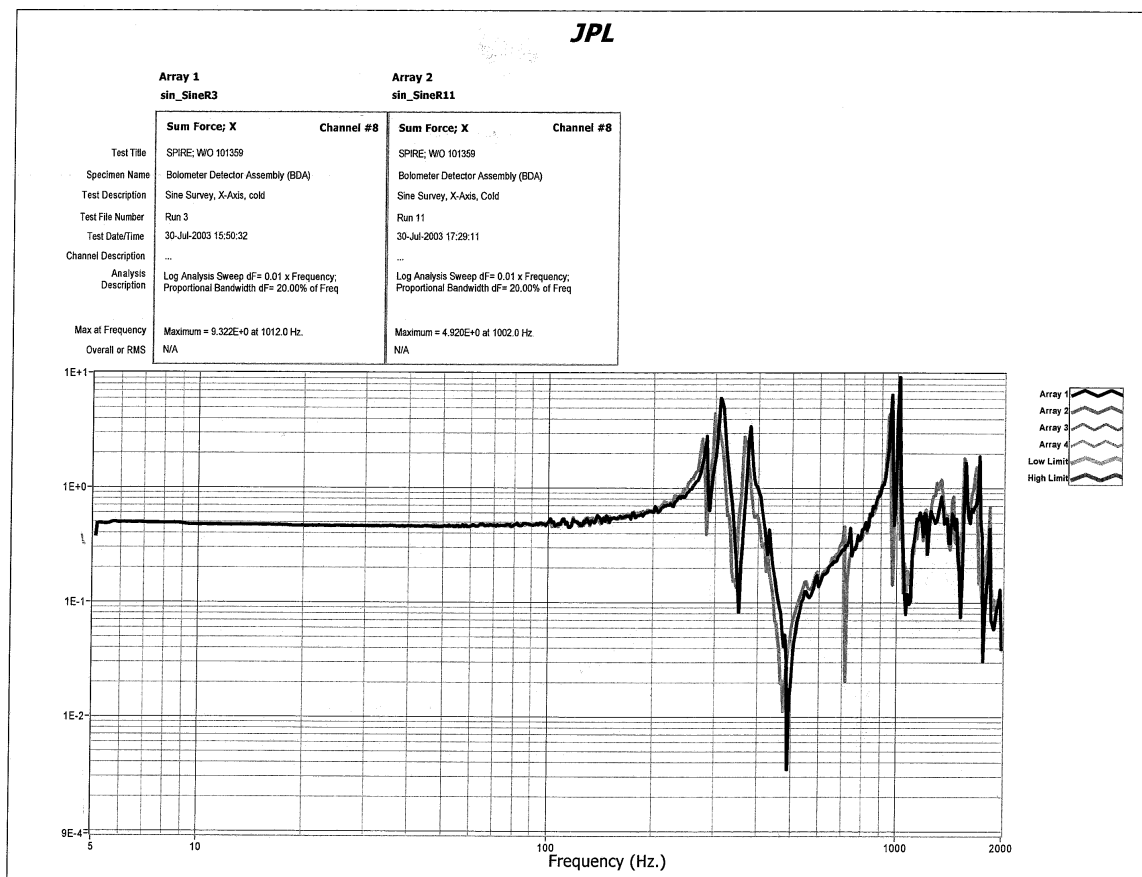

Y-axis Shake, Cold, Sine Surveys (Before and After 0 dB Random Vibe)

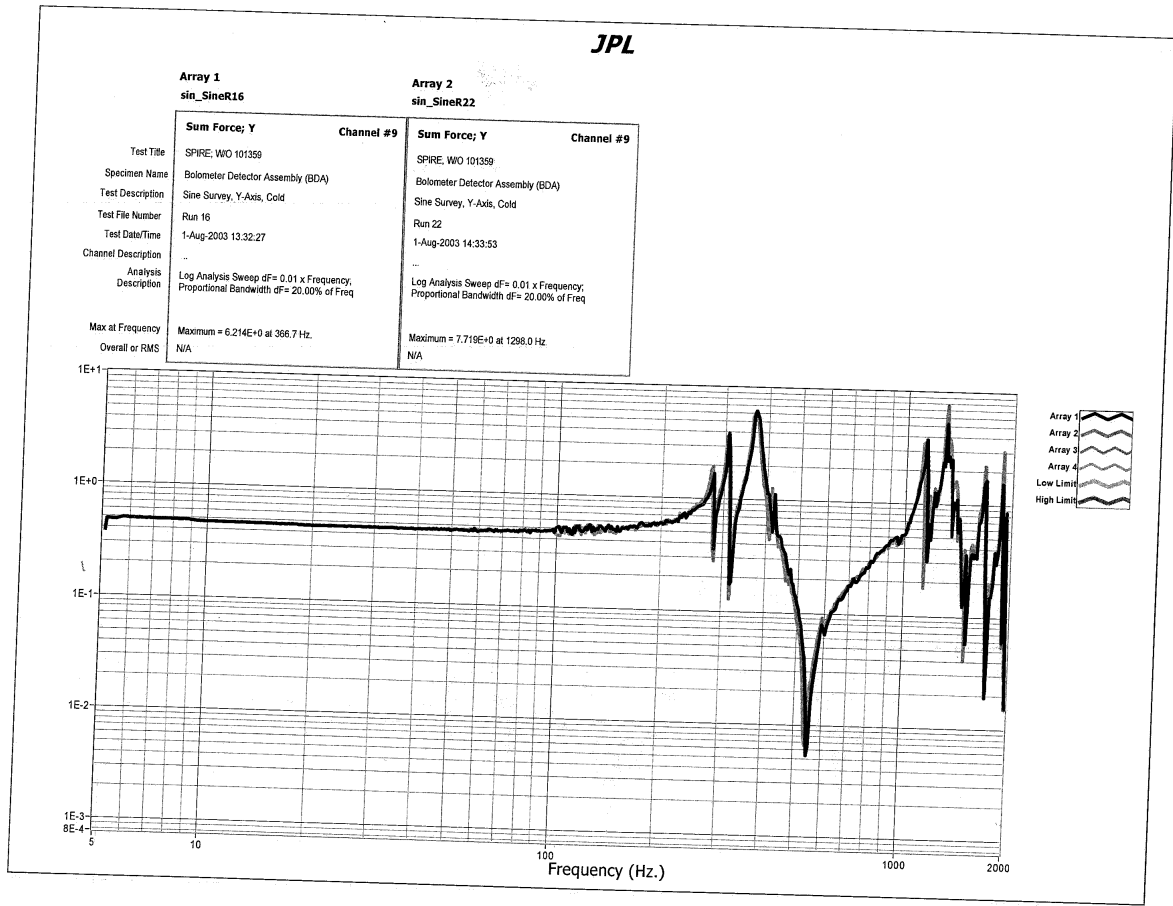

Z-axis Shake, Cold, Sine Surveys (Before and After 0 dB Random Vibe)

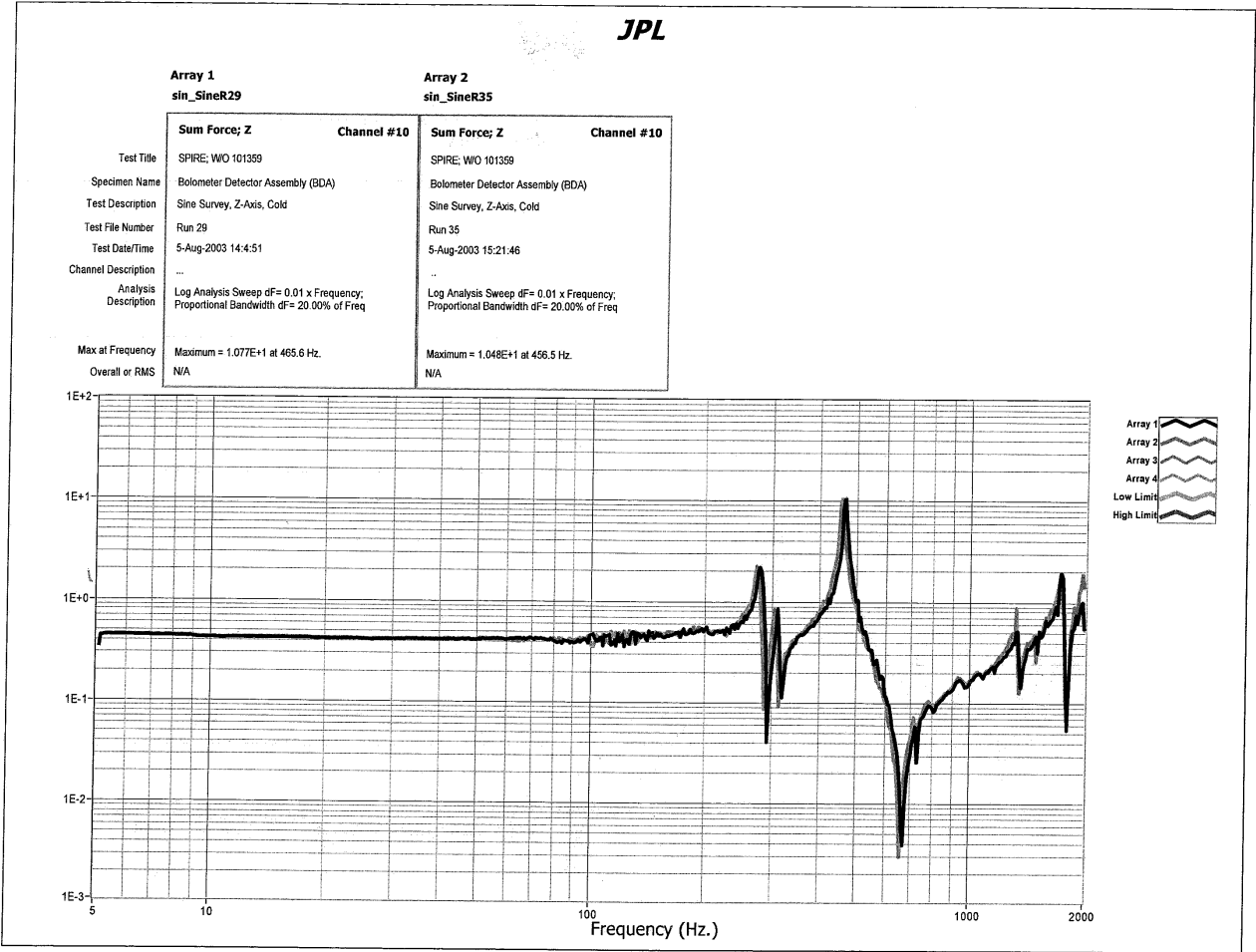

Date	Time	AIDS	Power	Mate	Demate	Transport	Notes
							Assembly Process Connector Mates
3-Jun-2004		240864		J03	J03		kapton cable sub-assy test
8-Jun-2004		240851		J01	J01		kapton cable sub-assy test
19-Jul-2004		240855		J02	J02		kapton cable sub-assytest
19-Jul-2004		240866		J04	J04		kapton cable sub-assy test
23-Aug-2004		242504		J01-J04	J01-J04		kapton cable post-installation test
25-Aug-2004		242504		J01-J04	J01-J04		Load resistor test
27-Aug-2004		242504		J01-J04	J01-J04		detector test, before feehorn installation
31-Aug-2004		242504		J01-J04	J01-J04		detector test, after feedhorn installation
							Assembly Complete
1-Sep-2004		243673		J01-J04	J01-J04		assembly complete electrical test (pre-bakeout)
1-Sep-2004		243673				x	103 -> MDL -> 103, for optical metrology
1-Sep-2004		243673					Filter installation,
2-Sep-2004		243673					staking and ink-stamp epoxy cure (66C, 3hrs)
3-Sep-2004		243673				x	103 -> bld 158 for Vacuum Bakeout (80C, 24 hrs, 10 ⁻⁵ torr)
7-Sep-2004		243673				x	bld 158 -> bld 170 for pre-vibe metrology, -> 103
7-Sep-2004		243673		J01-J04	J01-J04		post-bakeout, pre-vibe electrical test
8-Sep-2004		243693				x	103 -> 183 for shake prep.
8-Sep-2004		243693					installation into shake facility
9-Sep-2004		243693				x	183 -> 144 (shake lab)
9-Sep-2004		243693					pump / vent (for RmT pre-shake tests)
9-Sep-2004		243693					pump / cool to ~100K / Shake Test / warm / vent
10-Sep-2004		243693					pump / vent (for RmT post-shake tests)
10-Sep-2004		243693				x	144 -> 183, for removal from shake fixture
13-Sep-2004		243693				x	183 -> 170, for metrology
13-Sep-2004		243693				x	170 -> 103-109D
14-Sep-2004		243673		J01-J04	J01-J04		post-vibe electrical test
14-Sep-2004		243759				x	103 -> 183 for performance testing
14-Sep-2004		243759		J01-J04			Installation into BODAC test facility

LTR		ZONE	DESCRIPTION	CODE	DWN	CHK	STRUCT	MATL	THRM CONT	PEM	ENGR	DSGN SUPV	DATA MGT	RELEASE DATE
A			INITIAL RELEASE	B										12/7/01
B			UPDATED: MASS & CG'S, FILTER SHAPE, VOLUME, NEED AROUND CAPSTANS, CONN. POSITIONS. REMOVED MODES AND MASS PARTICIPATION; ROTATED PIXEL MAP 180°.	B	DJC	MAW				MIH	MAW		RGB	09/08/04
C			INCORPORATED ECR HR-SP-JPL-ECR-003; CHANGED FOCUS FDR -2 & -3; CHANGED DP TO DK	B										

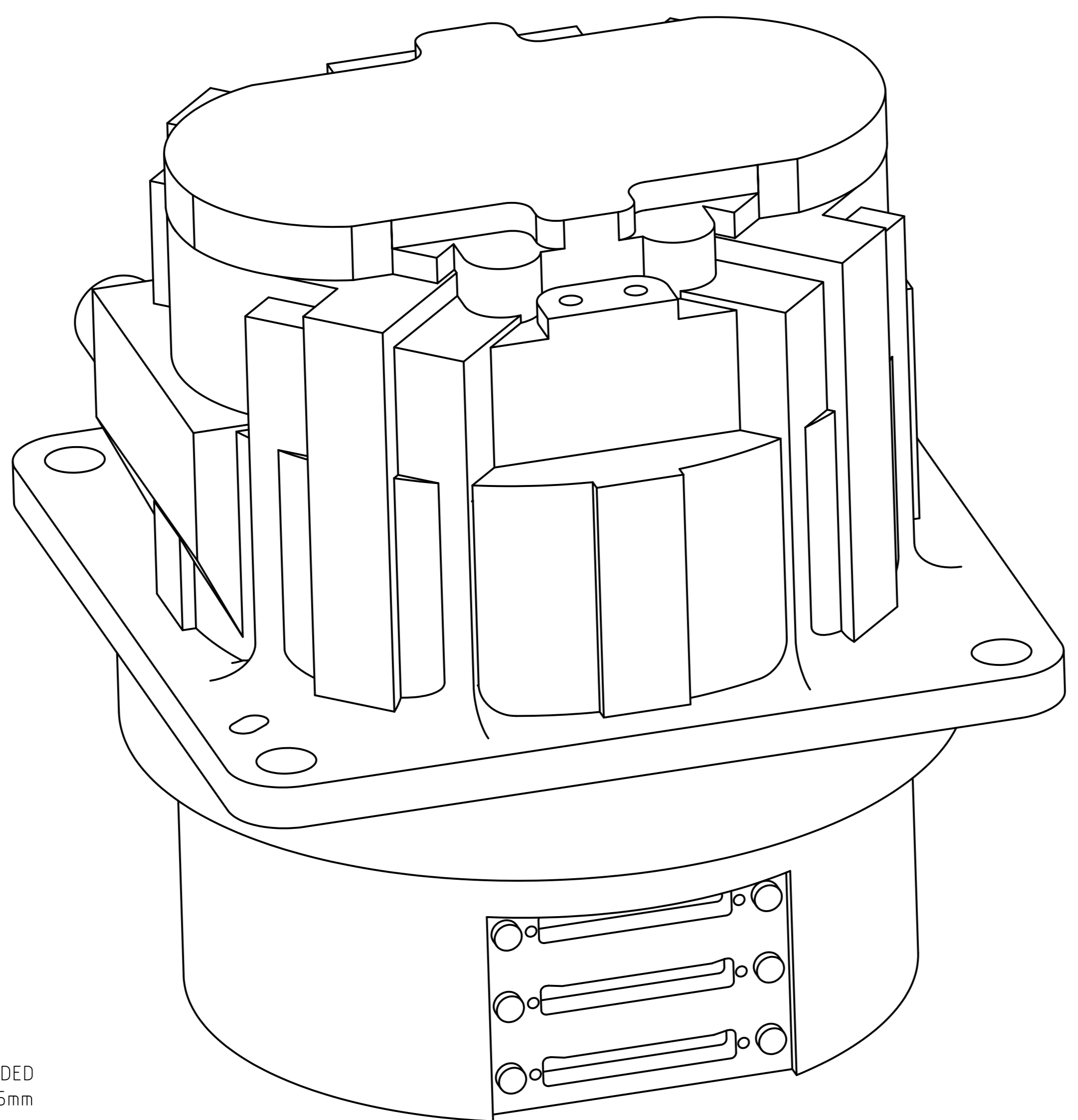

GENERAL VIEW
REFERENCE ONLY

- 9. ALL DIMENSIONS SHOWN FOR THE 300mK STAGE ARE FOR THE NOMINAL SUSPENDED POSITION. THE SUSPENDED UNIT MAY BE SHIFTED FROM NOMINAL POSITION ± 0.5 mm IN ANY AXIS.
- 8. ONLY PIXELS, DOWEL PIN HOLES, AND SLOTS VISIBLE. ALL OTHER FEATURES OMITTED FOR CLARITY.
- 7. FOR PHOTOMETER AND SPECTROMETER SUBSYSTEM INTERFACE DATA AND LAYOUT CONFIGURATION, SEE SHEETS 5-7.
- 6. DIMENSIONS IN {} ARE CALCULATED FOR OPERATING TEMPERATURE AND ARE PROVIDED FOR REFERENCE ONLY. ALL OTHER DIMENSIONS ARE BASED ON AN ASSEMBLY TEMPERATURE OF 20° C.
- 5. INDICATES CONNECTOR POSITION. CONNECTORS INSTALLED ARE NANONIC STM 051 M6SN.
- 4. REFER TO TABLES ON SHEETS 5, 6, AND 7 FOR DIFFERENCES BETWEEN DETECTOR ARRAYS.
- 3. ASSEMBLY REFERENCE DESIGNATOR, TITLE, PART NUMBER, REVISION LETTER, AND SERIAL NUMBER TO APPEAR AS SHOWN IN THIS AREA.

- 2. THIS IS THE INTERFACE CONTROL DRAWING FOR THE BOLOMETER DETECTOR ARRAY, JPL PART NUMBER 10209800. JPL DRAWING NUMBER 10209800 SHALL CONTAIN THE FOLLOWING NOTE: THIS ASSEMBLY MEETS THE INTERFACE REQUIREMENTS OF JPL INTERFACE CONTROL DRAWING 10209721.
- 1. THIS TECHNICAL DATA IS EXPORT CONTROLLED UNDER U.S. LAW AND IS BEING TRANSFERRED BY JPL TO PPARC PURSUANT TO THE NASA / PPARC LETTER OF AGREEMENT WHICH ENTERED INTO FORCE ON DECEMBER 2, 1999. THIS TECHNICAL DATA IS TRANSFERRED TO PPARC FOR USE EXCLUSIVELY ON THE NASA/PPARC SPIRE ON FIRST COOPERATIVE PROJECT, MAY NOT BE USED FOR ANY OTHER PURPOSE, AND SHALL NOT BE RE-TRANSFERRED OR DISCLOSED TO ANY OTHER PARTY WITHOUT THE PRIOR WRITTEN APPROVAL OF NASA.

NOTES: UNLESS OTHERWISE SPECIFIED

INTERFACE DRAWING

QTY REQD	ITEM NO	REF DES	CAGE NO	PART OR IDENTIFYING NO	NOMENCLATURE OR DESCRIPTION	SPECIFICATION	MATERIAL OR NOTE	ZONE
PARTS LIST								
				CONTRACT NO	1244858			
				APPD	DATE			
				DWN	D CRUMB	11/9/01		
				CHK	B BURDICK	11/14/01		
				STRUCT	K BROWNING	11/19/01		
				MATL	M KNDPP	11/19/01		
				THRM CONT				
				MSSL	A. J. COKER	11/7/01	SIZE	CAGE NO
				PEM	G. LILENTHAL	12/13/01	A1	23835
				ENGR	L. HUSTED	11/19/01	10209721	
				DSGN SUPV				
				DO NOT SCALE DRAWING				
				INTERPRET DWG PER	ASME Y14.100M			
				APPLICATION				
				NEXT ASSEMBLY	SPIRE			
				USED ON				
				RELEASED THROUGH	EDMG			
				JET PROPULSION LABORATORY				
				CALIFORNIA INSTITUTE OF TECHNOLOGY PASADENA, CA 91109				
				BOLOMETER DETECTOR ARRAY, SPIRE				
				SCALE NONE UNCLASSIFIED SHEET 1 OF 7				

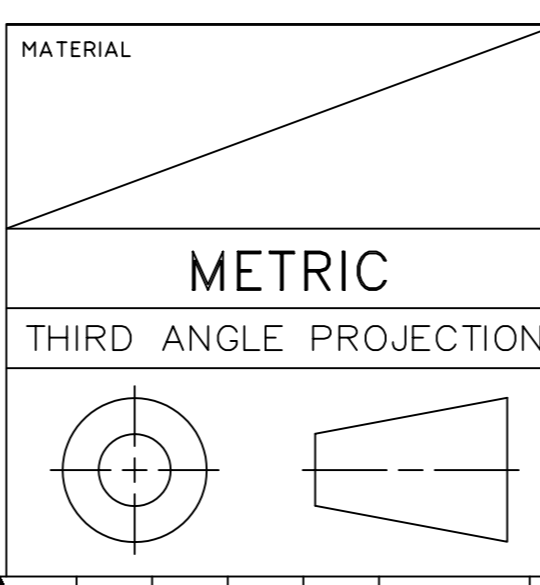

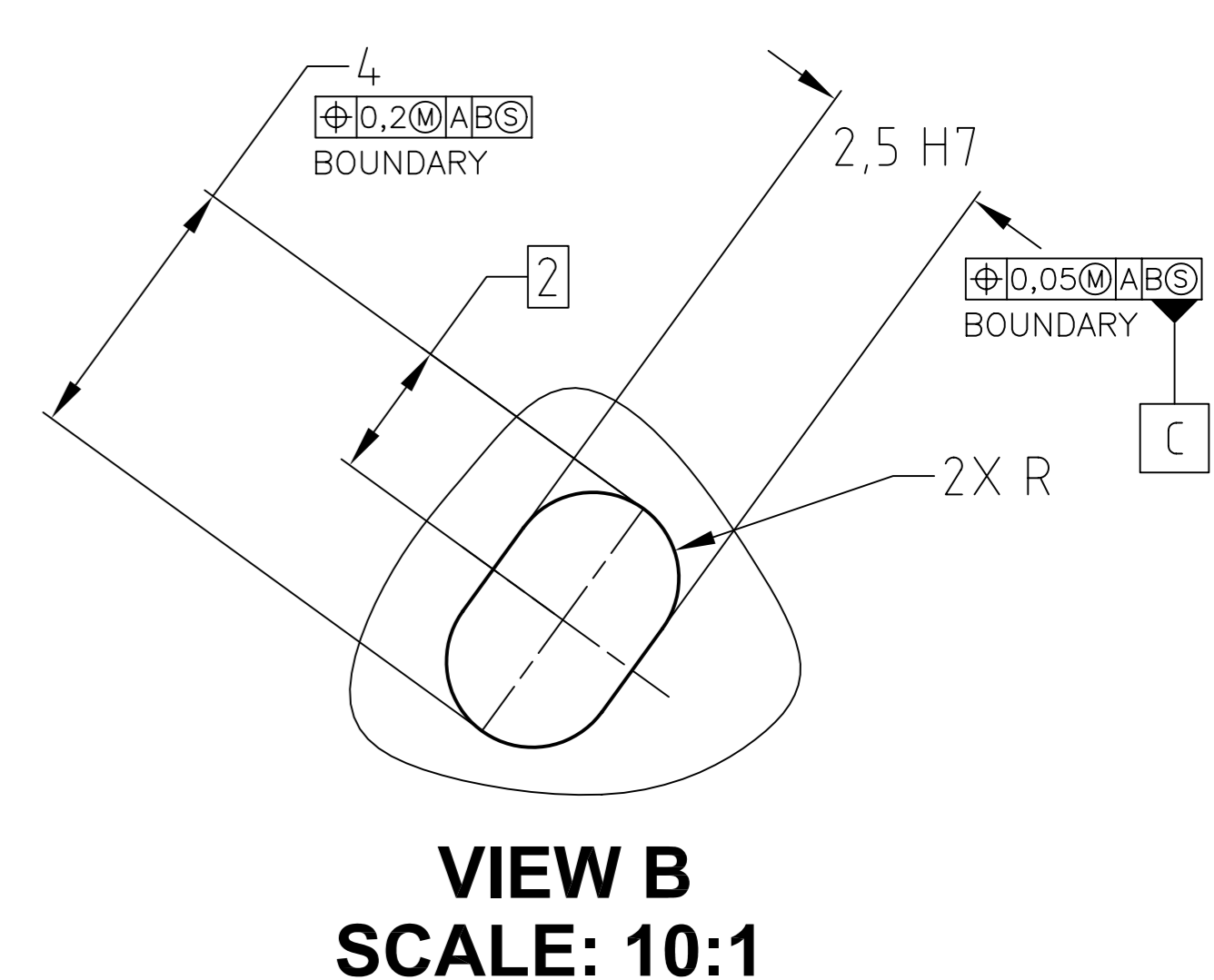
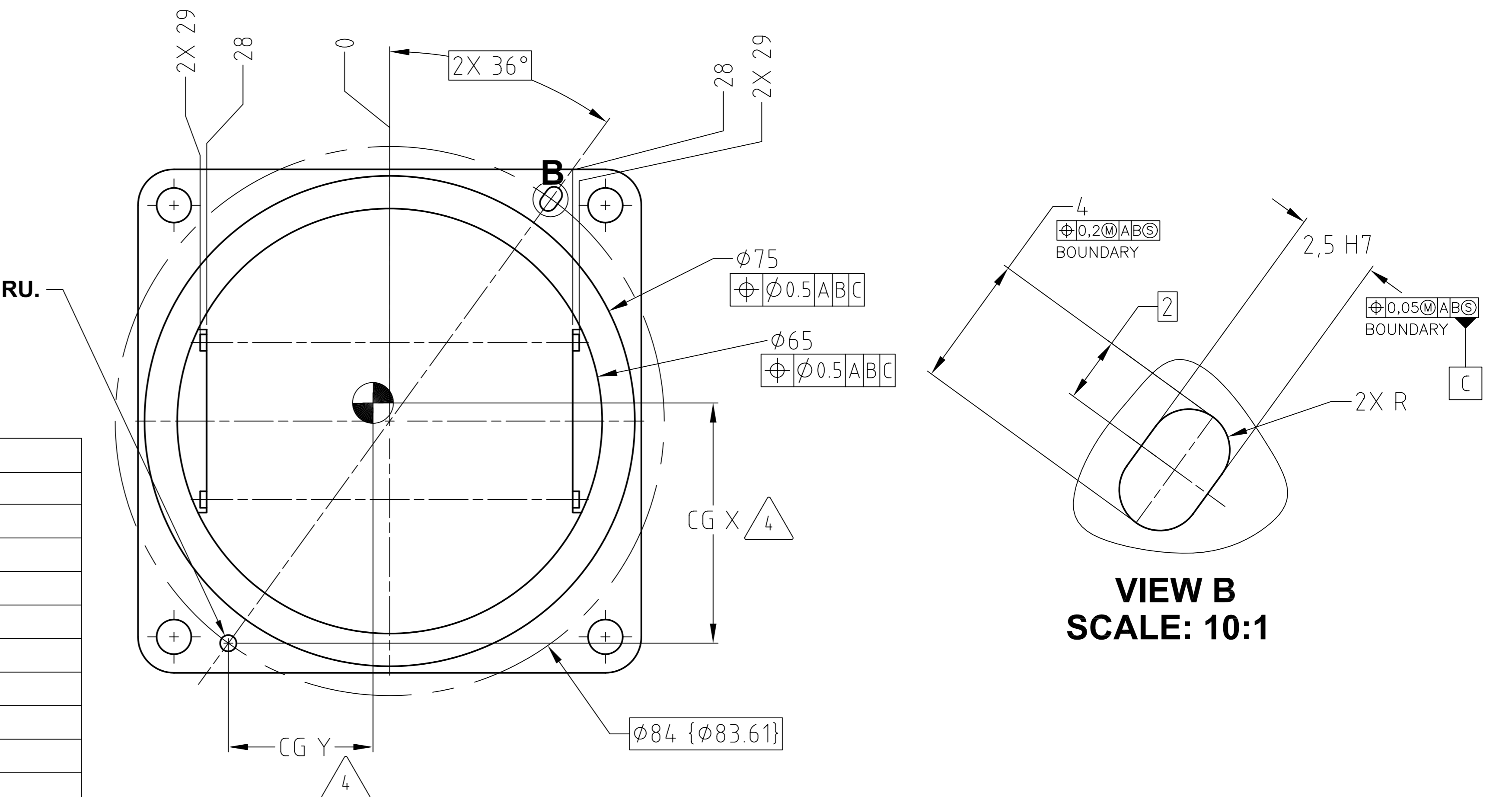
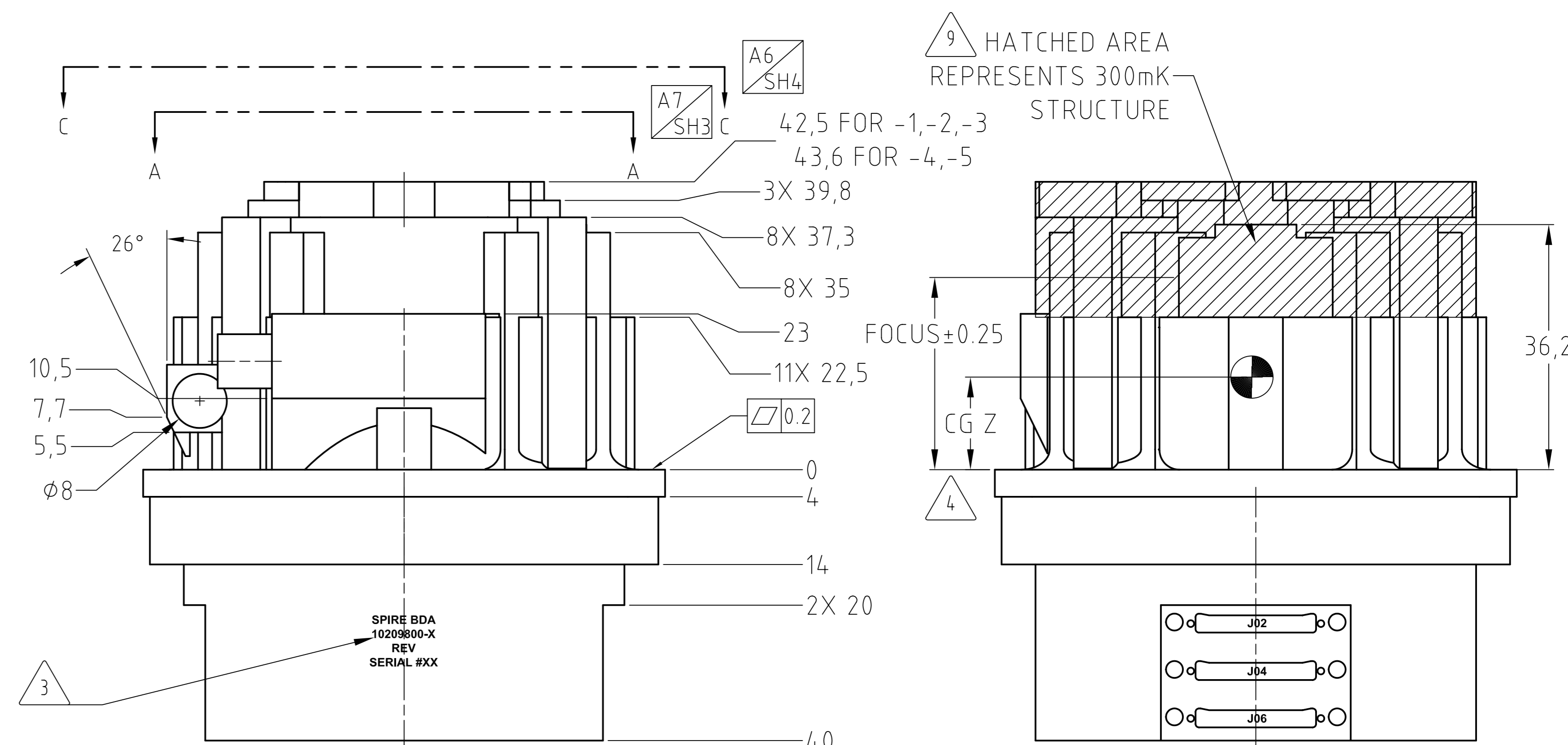
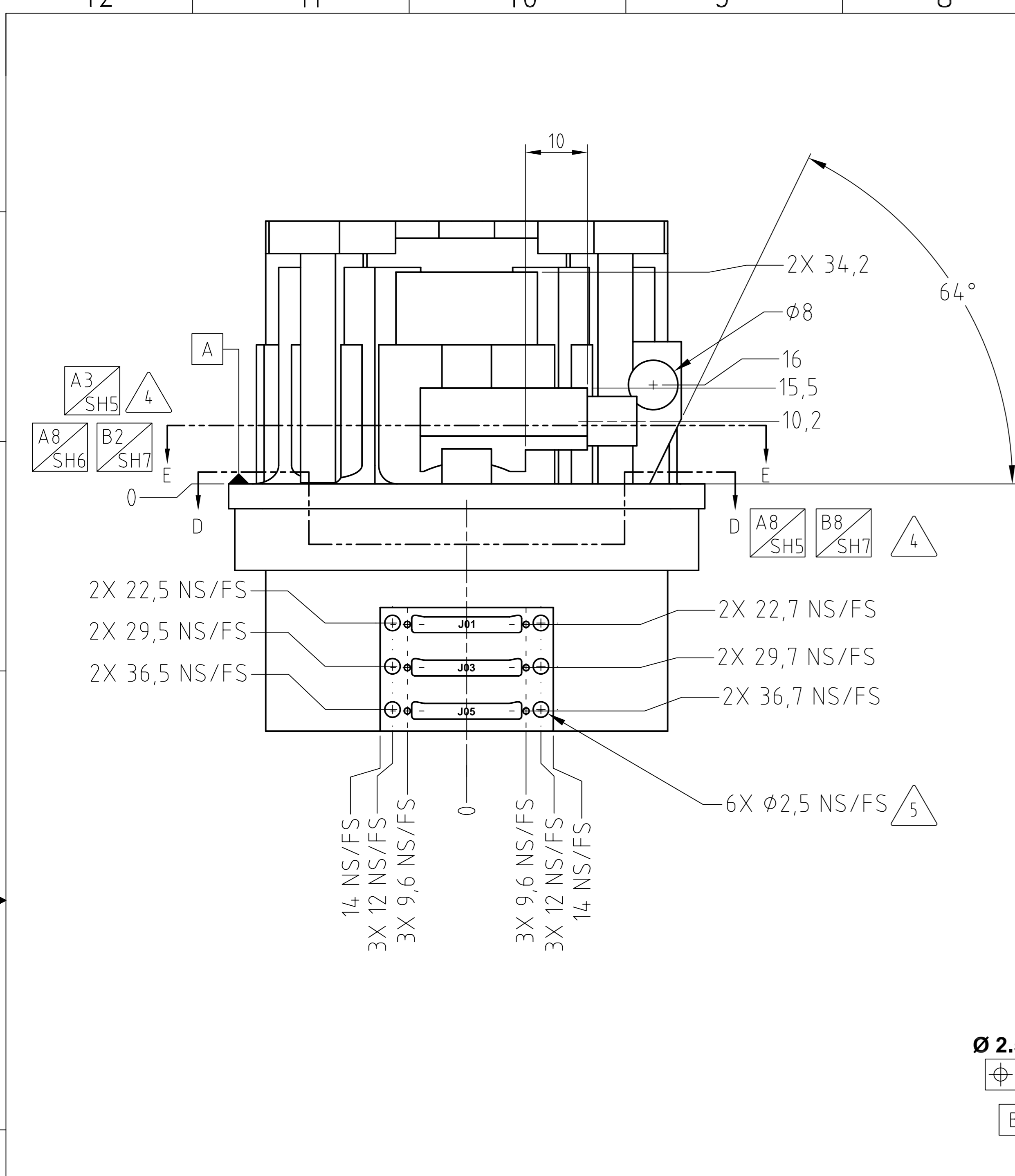

ALL CONNECTORS					
PIN #	PIN PURPOSE	PIN #	PIN PURPOSE	PIN #	PIN PURPOSE
1	SIGNAL A+	18	SIGNAL T+	35	SIGNAL J-
2	SIGNAL B+	19	SIGNAL U+	36	SIGNAL K-
3	SIGNAL C+	20	SIGNAL V+	37	SIGNAL L-
4	SIGNAL D+	21	SIGNAL W+	38	SIGNAL M-
5	SIGNAL E+	22	SIGNAL X+	39	SIGNAL N-
6	SIGNAL F+	23	SIGNAL Y+	40	SIGNAL P-
7	SIGNAL G+	24	SIGNAL Z+	41	SIGNAL R-
8	SIGNAL H+	25	SIGNAL BIAS V+	42	SIGNAL S-
9	SIGNAL I+	26	SIGNAL A-	43	SIGNAL T-
10	SIGNAL J+	27	SIGNAL B-	44	SIGNAL U-
11	SIGNAL K+	28	SIGNAL C-	45	SIGNAL V-
12	SIGNAL L+	29	SIGNAL D-	46	SIGNAL W-
13	SIGNAL M+	30	SIGNAL E-	47	SIGNAL X-
14	SIGNAL N+	31	SIGNAL F-	48	SIGNAL Y-
15	SIGNAL P+	32	SIGNAL G-	49	SIGNAL Z-
16	SIGNAL R+	33	SIGNAL H-	50	SIGNAL BIAS V-
17	SIGNAL S+	34	SIGNAL I-	51	SIGNAL BIAS GND

SIZE	CAGE NO	10209721	REV
A1	23835		C
SCALE 2:1	UNCLASSIFIED	SHEET 2 OF 7	REV 2/00

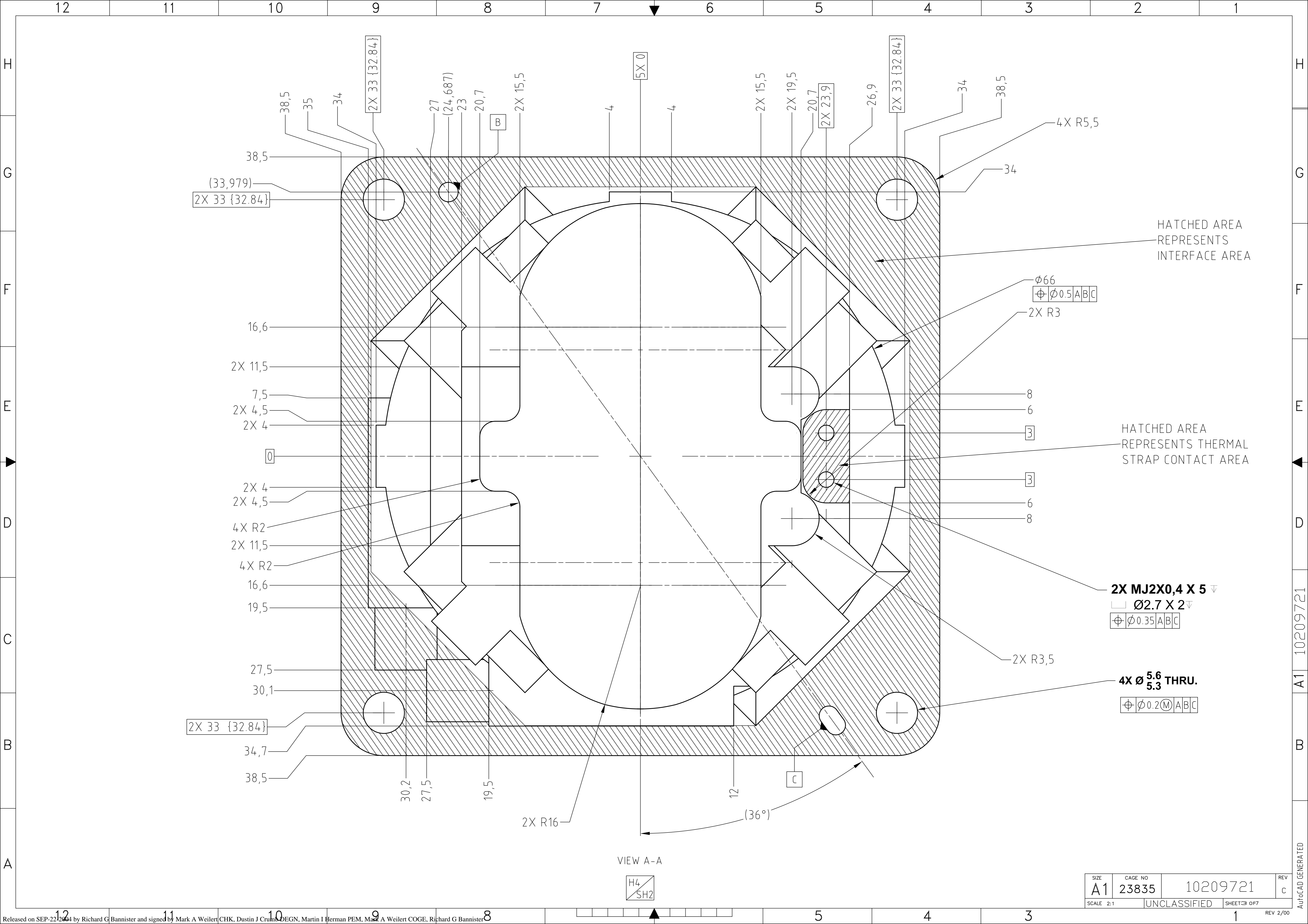

38,5 35 34 2X 33 {32.84} 27 (24,687) 23 20,7 2X 15,5 4 4 5X 0 2X 15,5 2X 19,5 20,7 2X 23,9 26,9 2X 33 {32.84} 34 38,5 4X R5,5 34
 (33,979) 2X 33 {32.84} 16,6 2X 11,5 7,5 2X 4,5 2X 4 0 2X 4 2X 4,5 4X R2 2X 11,5 4X R2 16,6 19,5 27,5 30,1 2X 33 {32.84} 34,7 38,5 30,2 27,5 19,5 12 2X R16 (36°)
 HATCHED AREA REPRESENTS INTERFACE AREA
 Ø66 ±0,5 ABC 2X R3 8 6 3 8 3 6 8
 HATCHED AREA REPRESENTS THERMAL STRAP CONTACT AREA
 2X MJ2X0,4 X 5
 Ø2.7 X 2
 ±0,35 ABC
 2X R3,5
 4X Ø 5.6 THRU.
 ±0,2 M ABC

VIEW A-A

H4
SH2

SIZE A1	CAGE NO 23835	10209721	REV c
SCALE 2:1	UNCLASSIFIED	SHEET 3 OF 7	REV 2/00

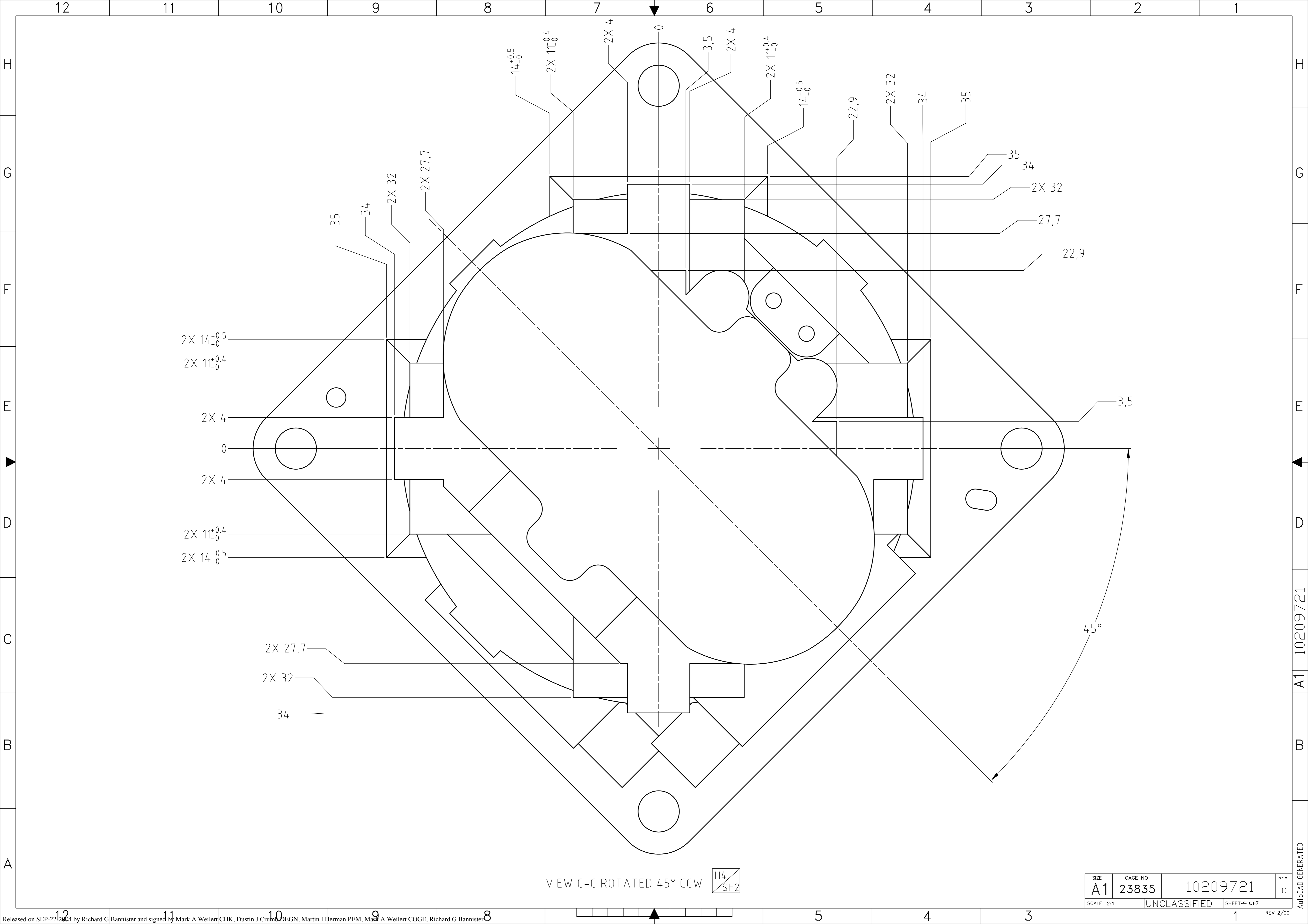

VIEW C-C ROTATED 45° CCW

H4
SH2

SIZE A1	CAGE NO 23835	10209721	REV c
SCALE 2:1	UNCLASSIFIED	SHEET 4 OF 7	REV 2/00

A1 10209721
AutoCAD GENERATED

SUBSYSTEM INTERFACE DATA			
UNIT: P/LW			
NUMBER: 10209800-1			
FOCUS: 32.8			
CONNECTOR POSITIONS USED: J05, J06			
MECHANICAL CHARACTERISTICS			
MASS: 632 g			
C.O.G. LOCATION W.R.T. LOCATION HOLE:			
X	34.4	Y	24.3
Z	6		
MOMENT OF INERTIA:			
I_x	772 Kg*mm ²	I_y	1,145 Kg*mm ²
I_z	1,423 Kg*mm ²		
MECHANICAL INTERFACE MATERIAL: 7075 AL			
SURFACE FINISH DESCRIPTION: CHEM FILM GOLD			
TOTAL CONTACT AREA: 1783 mm ²			
R.M.S. ROUGHNESS OF CONTACT AREA: 3.2 μ m			
THERMAL STRAP INTERFACE MATERIAL: CU 99.999% PURE			
THERMAL STRAP SURFACE FINISH DESCRIPTION: GOLD PLATED			
THERMAL STRAP CONTACT AREA: 57.5 mm ²			
THERMAL STRAP R.M.S. ROUGHNESS OF CONTACT AREA: 3.2 μ m			

SUBSYSTEM INTERFACE DATA			
UNIT: P/MW			
NUMBER: 10209800-2			
FOCUS: 32.2			
CONNECTOR POSITIONS USED: J01, J02, J03, J04			
MECHANICAL CHARACTERISTICS			
MASS: 632 g			
C.O.G. LOCATION W.R.T. LOCATION HOLE:			
X	34.4	Y	24.3
Z	8.5		
MOMENT OF INERTIA:			
I_x	764 Kg*mm ²	I_y	1,152 Kg*mm ²
I_z	1,428 Kg*mm ²		
MECHANICAL INTERFACE MATERIAL: 7075 AL			
SURFACE FINISH DESCRIPTION: CHEM FILM GOLD			
TOTAL CONTACT AREA: 1783 mm ²			
R.M.S. ROUGHNESS OF CONTACT AREA: 3.2 μ m			
THERMAL STRAP INTERFACE MATERIAL: CU 99.999% PURE			
THERMAL STRAP SURFACE FINISH DESCRIPTION: GOLD PLATED			
THERMAL STRAP CONTACT AREA: 57.5 mm ²			
THERMAL STRAP R.M.S. ROUGHNESS OF CONTACT AREA: 3.2 μ m			

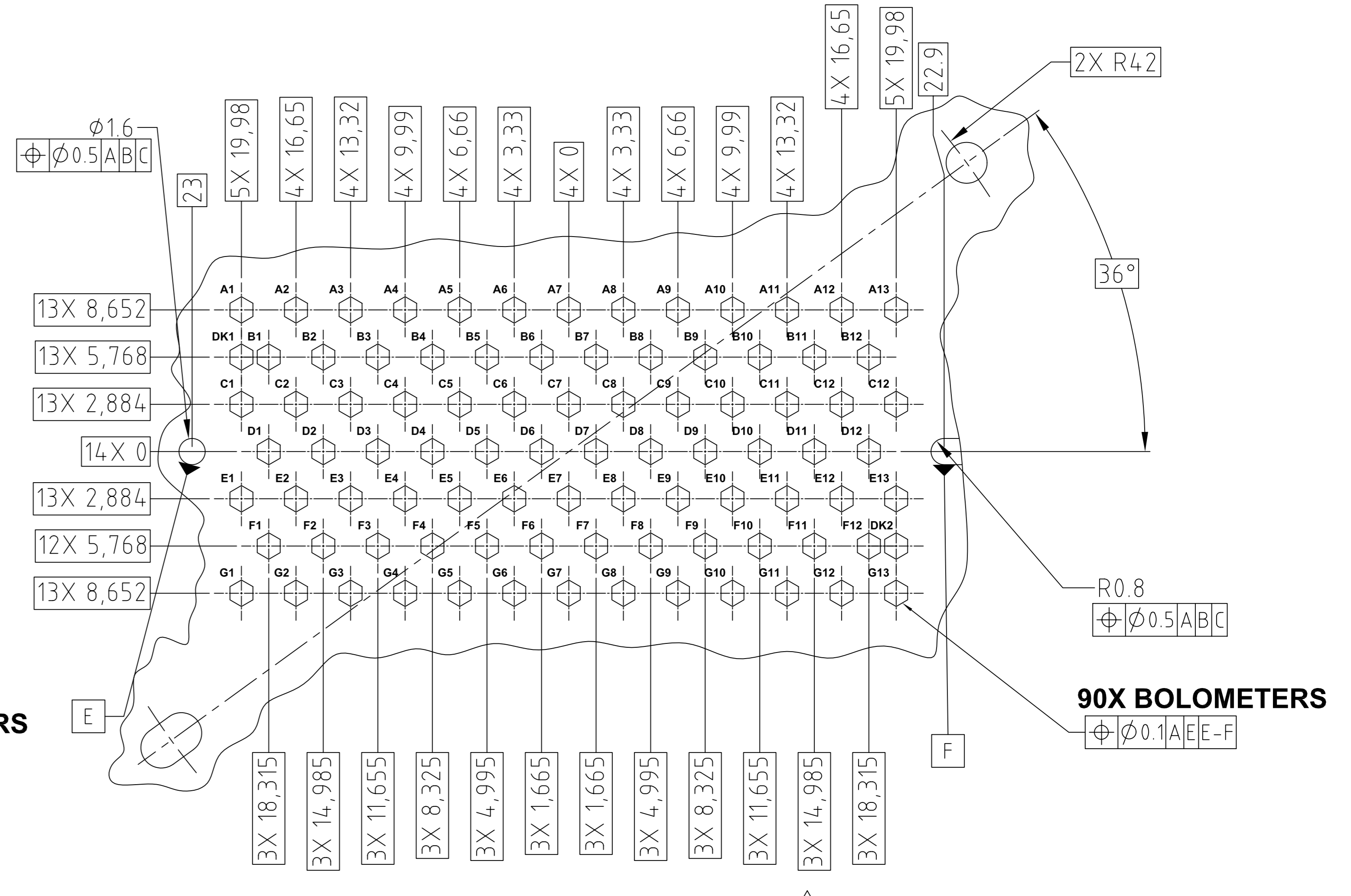
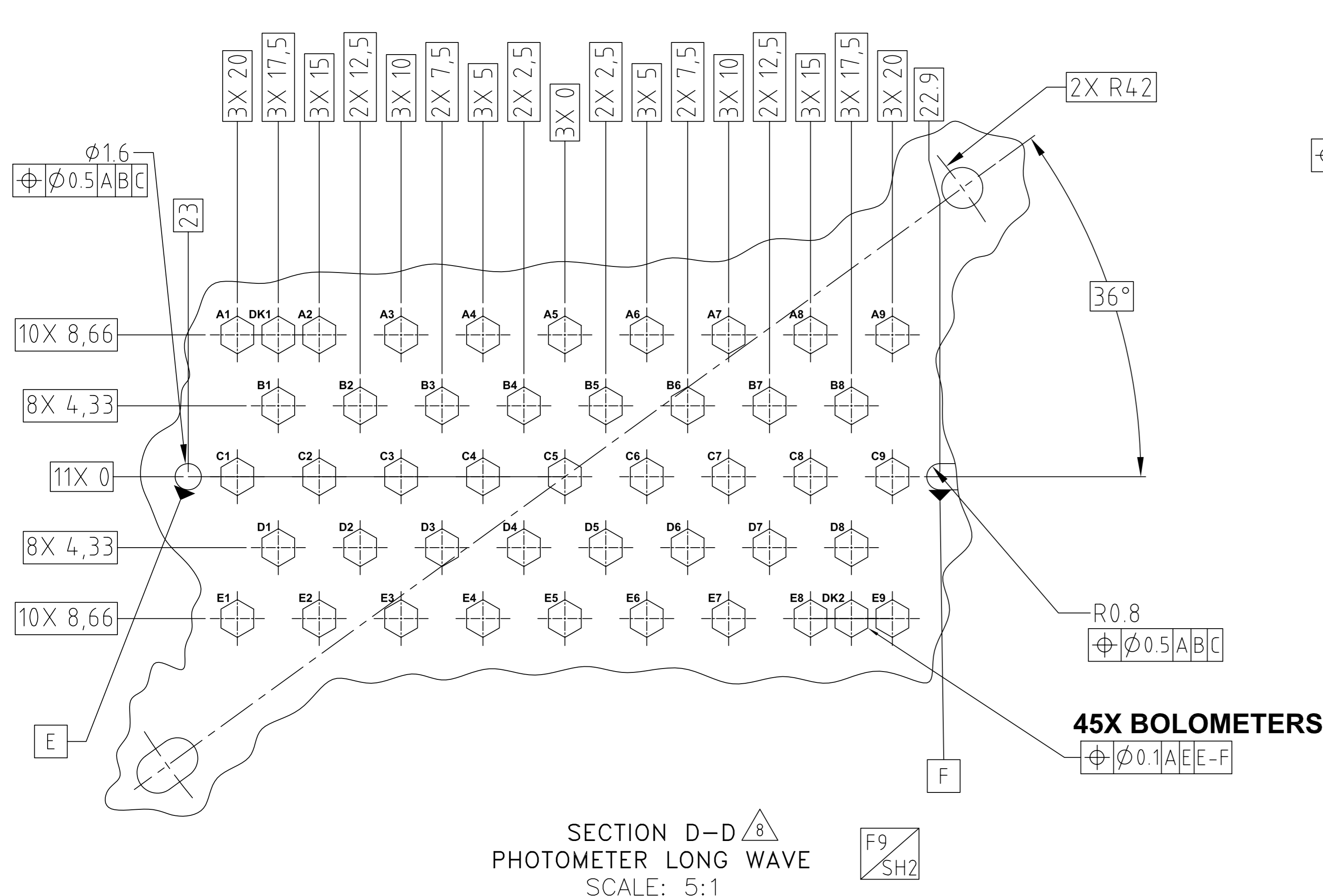

SIZE	CAGE NO	10209721	REV
A1	23835		c
SCALE	NOTED	UNCLASSIFIED	SHEET 5 OF 7

SUBSYSTEM INTERFACE DATA

UNIT: P/SW				
NUMBER: 10209800-3				
FOCUS: 23.8				
CONNECTOR POSITIONS USED: J01, J02, J03, J04, J05, J06				
MECHANICAL CHARACTERISTICS				
MASS: 600 g				
C.O.G. LOCATION W.R.T. LOCATION HOLE:		X 34.5	Y 24.3	Z 6.5
MOMENT OF INERTIA:		I _x 712 Kg*mm ²	I _y 1,074 Kg*mm ²	I _z 1,364 Kg*mm ²
MECHANICAL INTERFACE MATERIAL: 7075 AL				
SURFACE FINISH DESCRIPTION: CHEM FILM GOLD				
TOTAL CONTACT AREA: 1783 mm ²				
R.M.S. ROUGHNESS OF CONTACT AREA: 3.2 μm				
THERMAL STRAP INTERFACE MATERIAL: CU 99.999% PURE				
THERMAL STRAP SURFACE FINISH DESCRIPTION: GOLD PLATED				
THERMAL STRAP CONTACT AREA: 57.5 mm ²				
THERMAL STRAP R.M.S. ROUGHNESS OF CONTACT AREA: 3.2 μm				

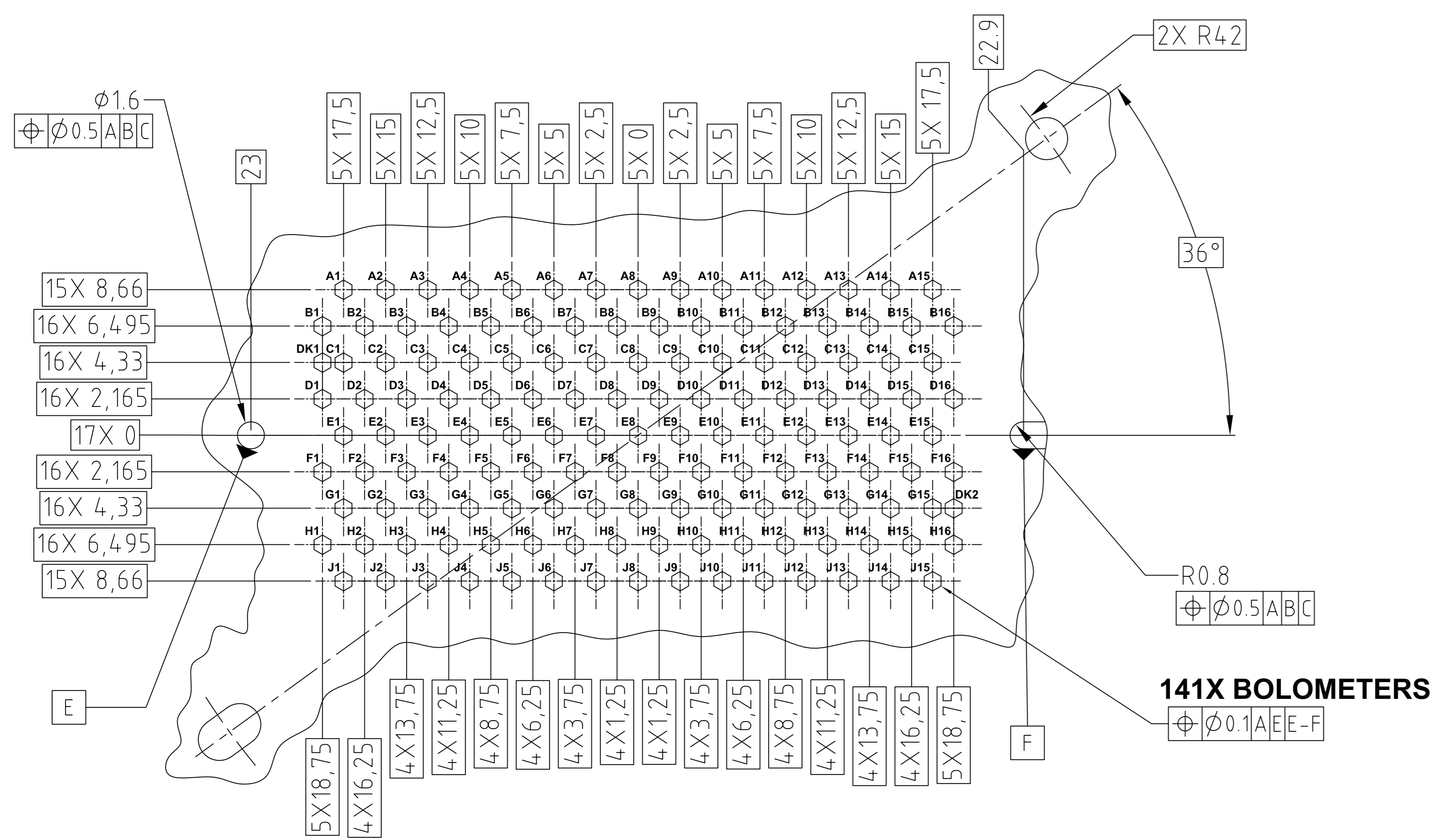

SECTION E-E \triangle
 PHOTOMETER SHORT WAVE
 SCALE: 5:1



SIZE A1	CAGE NO 23835	10209721	REV c
SCALE NOTED	UNCLASSIFIED	SHEET 6 OF 7	REV 2/00

SUBSYSTEM INTERFACE DATA			
UNIT: S/LW			
NUMBER: 10209800-4			
FOCUS: 36.9			
CONNECTOR POSITIONS USED: J05			
MECHANICAL CHARACTERISTICS			
MASS: 550 g			
C.O.G. LOCATION W.R.T. LOCATION HOLE:			
X	34.5	Y	24.1
Z	4.4		
MOMENT OF INERTIA:			
I _x	665 Kg*mm ²	I _y	990 Kg*mm ²
I _z	1,239 Kg*mm ²		
MECHANICAL INTERFACE MATERIAL: 7075 AL			
SURFACE FINISH DESCRIPTION: CHEM FILM GOLD			
TOTAL CONTACT AREA: 1783 mm ²			
R.M.S. ROUGHNESS OF CONTACT AREA: 3.2 μm			
THERMAL STRAP INTERFACE MATERIAL: CU 99.999% PURE			
THERMAL STRAP SURFACE FINISH DESCRIPTION: GOLD PLATED			
THERMAL STRAP CONTACT AREA: 57.5 mm ²			
THERMAL STRAP R.M.S. ROUGHNESS OF CONTACT AREA: 3.2 μm			

SUBSYSTEM INTERFACE DATA			
UNIT: S.SW			
NUMBER: 10209800-5			
FOCUS: 26.7			
CONNECTOR POSITIONS USED: J05, J06			
MECHANICAL CHARACTERISTICS			
MASS: 510 g			
C.O.G. LOCATION W.R.T. LOCATION HOLE:			
X	34.6	Y	24.2
Z	6		
MOMENT OF INERTIA:			
I _x	628 Kg*mm ²	I _y	936 Kg*mm ²
I _z	1,189 Kg*mm ²		
MECHANICAL INTERFACE MATERIAL: 7075 AL			
SURFACE FINISH DESCRIPTION: CHEM FILM GOLD			
TOTAL CONTACT AREA: 1783 mm ²			
R.M.S. ROUGHNESS OF CONTACT AREA: 3.2 μm			
THERMAL STRAP INTERFACE MATERIAL: CU 99.999% PURE			
THERMAL STRAP SURFACE FINISH DESCRIPTION: GOLD PLATED			
THERMAL STRAP CONTACT AREA: 57.5 mm ²			
THERMAL STRAP R.M.S. ROUGHNESS OF CONTACT AREA: 3.2 μm			

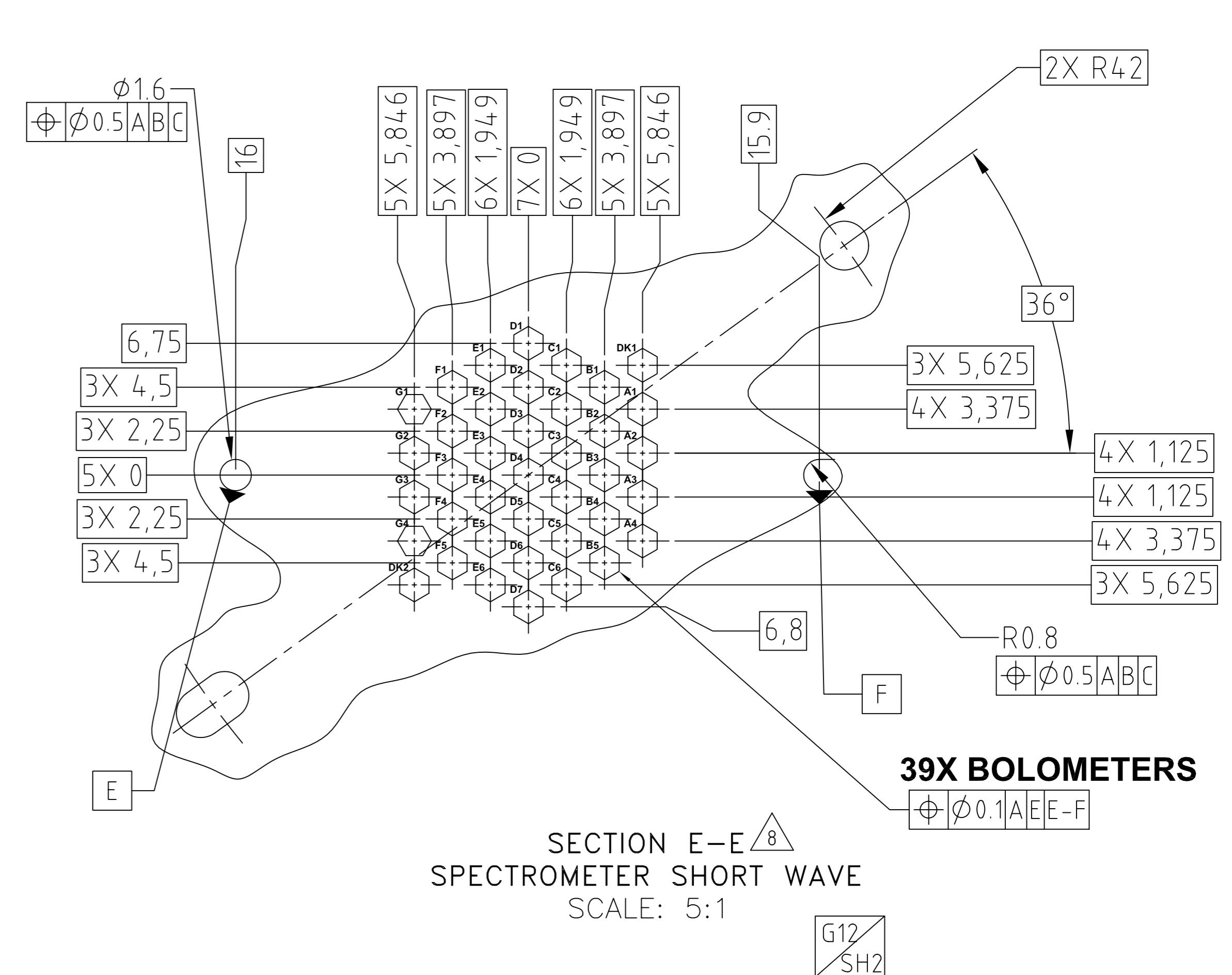
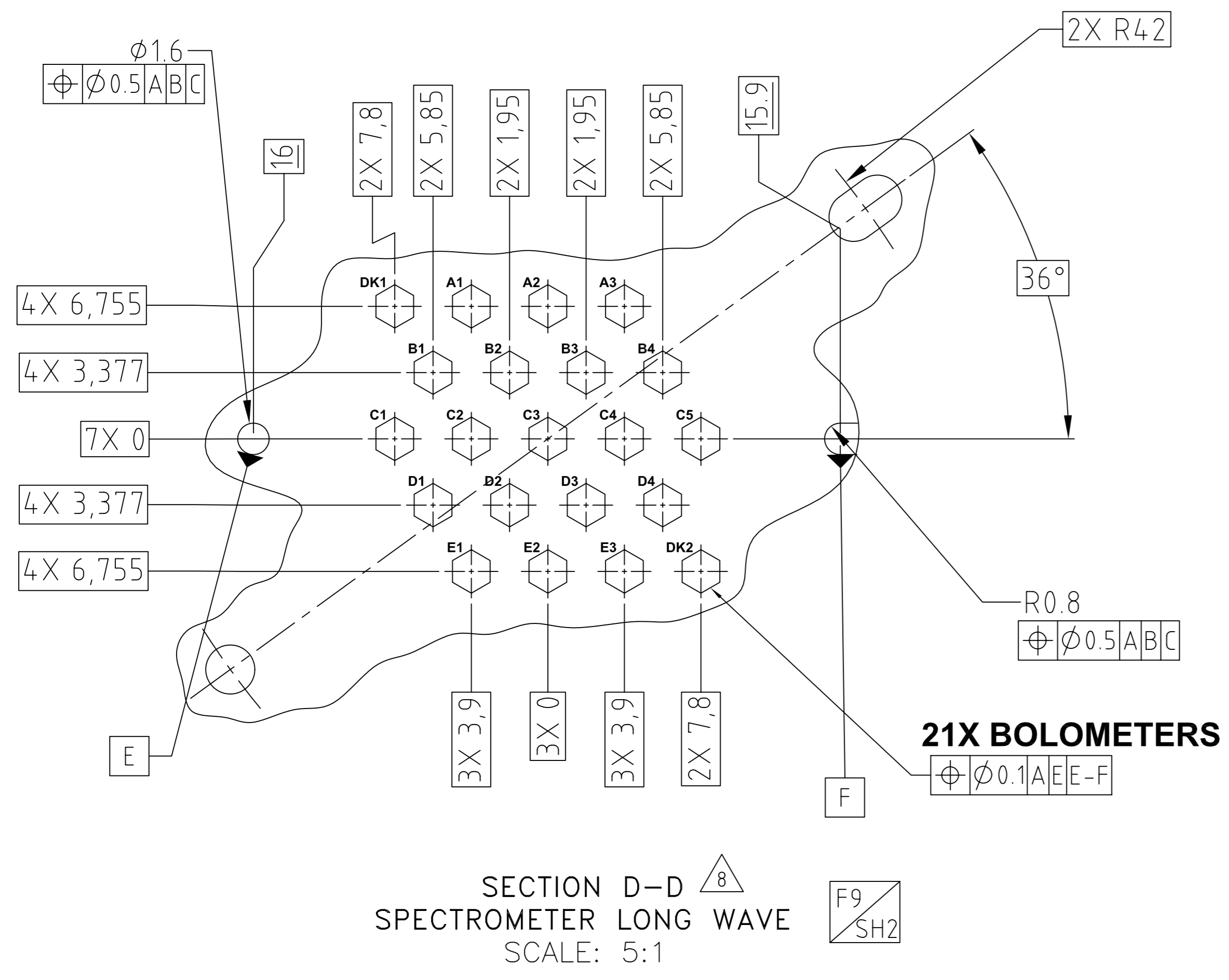



TR	ZONE	DESCRIPTION	DATE	BY	CHK	APP	REV	DATE
A		INITIAL RELEASE						
B		INCORPORATED ESR ISSUES	3	JAC				3/18/03
C		INCORPORATED RAL ESR HR-SP-RAL-EOR-005	3	JAC				07/22/04

ARRAY DEFINITION	10209800-1 P/LW		10209800-2 P/MW				10209800-3 P/SW				10209800-4 S/LW		10209800-5 S/SW			
	J05	J06	J01	J02	J03	J04	J01	J02	J03	J04	J05	J06	J05	J06		
BDA CONNECTOR	A	R1	E1	A7	E7	A13	R1	D6	F12	R1	E1	D11	G5	R1		
	B	A8	E2	A6	D7	T1	G1	B6	J11	D16	F1	A10	H6	T1		
	C	A7	E3	B6	F7	B12	T2	C5	E12	T1	T2	E10	J6	C1		
	D	A6	E4	C7	E8	C13	E1	A5	H12	B16	H1	C10	F6	DK1	A2	
	E	A9	D1	A5	G8	A12	D1	E5	G12	C15	G1	B10	G6	B1	A1	
	F	C9	D2	B5	F8	D12	F1	B5	F13	A15	G1	D10	H7	D1	DK1	
	G	B8	D3	C6	E9	C12	E2	D5	E13	D15	H2	A9	F7	E1	B3	
	H	B7	D4	D6	G9	B11	G2	C4	J12	B15	F2	E9	J7	A1	B2	
	I	C7	C1	B4	D9	A11	F2	A4	H13	C14	J2	C9	G7	C2	B1	
	J	B5	C3	C5	F9	E13	G3	D4	G13	D14	G2	B9	H8	D2	C3	
	K	B6	C5	D4	E10	D11	E3	B4	F14	A14	H3	D9	F8	B2	C2	
	L	A5	T2	A4	G10	C11	D3	C3	E14	A13	J3	A8	G8	E2	C1	
	M	T1	E5	C4	F10	B10	F3	B3	J13	B14	E2	C8	J8	A2	D3	
	N	B4	C6	B3	E11	A10	G4	A3	H14	C13	F3	E8	F9	C3	D2	
	P	C4	C8	C3	G11	D10	E4	A2	G14	B13	G3	D8	H9	D3	D1	
	Q	B3	D5	B2	F11	B9	F4	D3	J14	D13	H4	B8	G9	B3	E3	
	R	C2	D6	D2	E12	C10	E5	C2	F15	A12	J4	C7	J9	E3	E2	
	S	B2	D7	A3	G12	C9	D5	B2	H15	C12	E3	E7	F10	C4	E1	
	T	B1	D8	A2	F12	A9	F5	D2	J15	D12	F4	A7	H10	DK2	F3	
	U	A3	E7	C2	G13	B8	G5	A1	G15	B12	G4	D7	G10	D4	F2	
	V	A4	E6	B1	DK2	A8	E6	C1	H16	E11	H5	B7	F11	C5	F1	
	W	A1	E8	A1	T/C	D8	G6	B1	DK2	A11	E4	C6	J10	B4	G1	
	X	DK1	DK2	DK1	T/C	C8	F6	DK1	F16	C11	J5	E6	H11	A3	T1	
	Y	A2	E9	C1	T/C	B7	G7	D1	E15	B11	F5	A6	G11	T2	G2	
	Z															
	JFET INTERFACE	AA	HSJFP07	HSJFP08	HSJFP11	HSJFP12	HSJFP09	HSJFP10	HSJFP03	HSJFP04	HSJFP01	HSJFP02	HSJFP05	HSJFP06	HSJFS03	HSJFS01
BB		J14	J16	J22	J24	J18	J20	J06	J08	J02	J04	J10	J12	J06	J02	J04
CC		J13	J15	J21	J23	J17	J19	J05	J07	J01	J03	J09	J11	J05	J01	J03
DD		HSJFP07	HSJFP08	HSJFP11	HSJFP12	HSJFP09	HSJFP10	HSJFP03	HSJFP04	HSJFP01	HSJFP02	HSJFP05	HSJFP06	HSJFS03	HSJFS01	HSJFS02
FPU HARNESS		J35	J36	J39	J40	J37	J38	J31	J32	J29	J30	J33	J34	J13	J11	J12
		HSJFP07	HSJFP08	HSJFP11	HSJFP12	HSJFP09	HSJFP10	HSJFP03	HSJFP04	HSJFP01	HSJFP02	HSJFP05	HSJFP06	HSJFS03	HSJFS01	HSJFS02
CRYO HARNESS		J47	J48	J51	J52	J49	J50	J43	J44	J41	J42	J45	J46	J17	J15	J16

- INFORMATION IN THIS DOCUMENT IS ALSO CONTAINED IN THE HARNESS DEFINITION DOCUMENT, RAL DOCUMENT SPIRE-RAL-PRJ-006808. IN AREAS WHERE THERE ARE CONFLICTS, THE HARNESS DEFINITION DOCUMENT TAKES PRECEDENCE.
 - ESD PROTECTION RESISTORS ARE 7 TIMES THE SOURCE RESISTOR.
 - GROUND WIRE TO BE TERMINATED AT INSTRUMENT INTEGRATION. WIRE WILL HAVE A MINIMUM LENGTH OF 150MM.
 - UNLESS OTHERWISE NOTED, \perp IS JFET CHASSIS GROUND.
 - JFET MEMBRANE HEATER IS 0.0204 TIMES THE SOURCE RESISTOR.
 - ALL RESISTORS HAVE A TOLERANCE OF $\pm 40\%$.
 - THIS TECHNICAL DATA IS EXPORT CONTROLLED UNDER U.S. LAW AND IS BEING TRANSFERRED BY JPL TO PPARC PURSUANT TO THE NASA / PPARC LETTER OF AGREEMENT WHICH ENTERED INTO FORCE ON DECEMBER 2, 1995. THIS TECHNICAL DATA IS TRANSFERRED TO PPARC FOR USE EXCLUSIVELY ON THE NASA/PPARC SPIRE ON FIRST COOPERATIVE PROJECT. MAY NOT BE USED FOR ANY OTHER PURPOSE, AND SHALL NOT BE RE-TRANSFERRED OR DISCLOSED TO ANY OTHER PARTY WITHOUT THE PRIOR WRITTEN APPROVAL OF NASA.
- NOTES: UNLESS OTHERWISE SPECIFIED

QTY	ITEM NO	REF DES	CASE NO	PART OR IDENTIFYING NO	NOMENCLATURE OR DESCRIPTION	SPECIFICATION	MATERIAL OR NOTE	ZONE
					PARTS LIST			
					UNLESS OTHERWISE SPECIFIED DIMENSIONS ARE IN MILLIMETERS			
					LINEAR TOLERANCES:			
					D-F 6-30 ± 0.1			
					OVER 30-120 ± 0.2			
					OVER 120-315 ± 0.3			
					OVER 315-1000 ± 0.5			
					OVER 1000 ± 1.2			
					ANGULAR TOLERANCES:			
					$\pm 0.5^\circ$			
					MATERIAL:			
					SPIRE			
					NEXT ASSEMBLY USED ON			
					APPLICATION			

FRAM CASE NO 10209725

1 OF 2 23835

DRAWING NUMBER 10209725

REV BY NO C 1

CONTRACT NO 1024858

DATE 2/26/03

DATE 3/17/03

DATE 2/11/03

DATE 2/19/03

DATE 3/17/03

DATE 2/26/03

JET PROPULSION LABORATORY
PASADENA, CA 91109

RELEASED THROUGH EDMS

WIRING SCHEMATIC,
SPIRE

SCALE NONE UNCLASSIFIED SHEET 1 OF 1

SPIRE Assembly Array/Backshort Assembly Traveller
 Revised by A Turner March 5, 2003

AIDS: 243660

Device #	PMW 2.1	PMW BS 3.2
Date	8-Jun-04	
Collected by	A Turner	

Height measurements of Backshort to Detector to NTD chip

a= BS height
 b= to web
 c= NTD height

Device Thickness Measurements		
Zero at	Measure at	Meas (mm)
1	1	0.0000
1	2	-1.0295
1	3	-1.0320
1	4	-1.0355
1	5	-0.0005
1	6	-1.0215
1	7	-1.0310
1	8	-1.0340
1	9	-1.0390
1	10	-1.0440
1	11	-1.0210
1	12	-1.0305
1	13	-1.0350
1	14	-1.0380
1	15	-1.0450
1	16	0.0015
1	17	-1.0250
1	18	-1.0300
1	19	-1.0370
1	20	0.0005

Targets	mm	tol (mm)
Stack thick	1.0285	0.0390
NTD chip	0.0250	0.0100
BS dist	0.091	0.01

Stack Thickness (mm)	
Average	1.0345
max	1.0455
min	1.0205
p-p	0.0250
Backshort Thickness(mm)	
Average	0.9511
max	0.9540
min	0.9470
p-p	0.0070
Backshort Distance (mm)	
Average	0.0833
max	0.0925
min	0.0700
p-p	0.0225
NTD Chip Thickness(mm)	
Average	0.0305
max	0.0355
min	0.0245
p-p	0.0110

Pillar Height Measurements							
Zero at	Row	Pixel	a (mm)	b(mm)	c(mm)	NTD chip (mm)	BS dist (mm)
1	A	1	-0.9470	-1.0255	-1.0590	0.0335	0.0785
1	A	2	-0.9470	-1.0275	-1.0570	0.0295	0.0805
1	A	3	-0.9475	-1.0295	-1.0575	0.0280	0.0820
1	A	4	-0.9485	-1.0300	-1.0630	0.0330	0.0815
1	A	5	-0.9485	-1.0315	-1.0645	0.0330	0.0830
1	A	6	-0.9495	-1.0315	-1.0650	0.0335	0.0820
1	A	7	-0.9495	-1.0320	-1.0645	0.0325	0.0825
1	A	8	-0.9505	-1.0330	-1.0670	0.0340	0.0825
1	A	9	-0.9505	-1.0335	-1.0635	0.0300	0.0830
1	A	10	-0.9505	-1.0350	-1.0705	0.0355	0.0845
1	A	11	-0.9510	-1.0360	-1.0670	0.0310	0.0850
1	A	12	-0.9510	-1.0380	-1.0690	0.0310	0.0870
1	A	13	-0.9505	-1.0430	-1.0710	0.0280	0.0925
1	K	1	-0.9485	-1.0260	-1.0555	0.0295	0.0775
1	B	1	-0.9485	-1.0260	-1.0550	0.0290	0.0775
1	B	2	-0.9485	-1.0290	-1.0610	0.0320	0.0805
1	B	3	-0.9495	-1.0305	-1.0610	0.0305	0.0810
1	B	4	-0.9495	-1.0315	-1.0610	0.0295	0.0820
1	B	5	-0.9500	-1.0335	-1.0640	0.0305	0.0835
1	B	6	-0.9500	-1.0335	-1.0655	0.0320	0.0835
1	B	7	-0.9510	-1.0350	-1.0680	0.0330	0.0840
1	B	8	-0.9510	-1.0360	-1.0665	0.0305	0.0850
1	B	9	-0.9510	-1.0360	-1.0690	0.0330	0.0850
1	B	10	-0.9510	-1.0380	-1.0690	0.0310	0.0870
1	B	11	-0.9510	-1.0390	-1.0690	0.0300	0.0880
1	B	12	-0.9510	-1.0405	-1.0715	0.0310	0.0895
1	T	1		-1.0420	-1.0750	0.0330	
1	C	1	-0.9485	-1.0255	-1.0565	0.0310	0.0770
1	C	2	-0.9485	-1.0285	-1.0545	0.0260	0.0800
1	C	3	-0.9500	-1.0315	-1.0600	0.0285	0.0815
1	C	4	-0.9500	-1.0330	-1.0660	0.0330	0.0830
1	C	5	-0.9500	-1.0340	-1.0655	0.0315	0.0840
1	C	6	-0.9510	-1.0345	-1.0645	0.0300	0.0835
1	C	7	-0.9515	-1.0350	-1.0695	0.0345	0.0835
1	C	8	-0.9515	-1.0355	-1.0660	0.0305	0.0840
1	C	9	-0.9515	-1.0370	-1.0670	0.0300	0.0855
1	C	10	-0.9515	-1.0380	-1.0710	0.0330	0.0865
1	C	11	-0.9515	-1.0395	-1.0705	0.0310	0.0880
1	C	12	-0.9515	-1.0415	-1.0730	0.0315	0.0900
1	C	13	-0.9515	-1.0435	-1.0735	0.0300	0.0920
1	D	1	-0.9490	-1.0265	-1.0600	0.0335	0.0775
1	D	2	-0.9495	-1.0295	-1.0565	0.0270	0.0800
1	D	3	-0.9495	-1.0320	-1.0565	0.0245	0.0825
1	D	4	-0.9505	-1.0340	-1.0655	0.0315	0.0835
1	D	5	-0.9515	-1.0360	-1.0655	0.0295	0.0845
1	D	6	-0.9520	-1.0355	-1.0680	0.0325	0.0835
1	D	7	-0.9520	-1.0365	-1.0690	0.0325	0.0845
1	D	8	-0.9520	-1.0385	-1.0700	0.0315	0.0865
1	D	9	-0.9520	-1.0395	-1.0700	0.0305	0.0875
1	D	10	-0.9520	-1.0410	-1.0665	0.0255	0.0890
1	D	11	-0.9520	-1.0420	-1.0725	0.0305	0.0900
1	D	12	-0.9520	-1.0435	-1.0710	0.0275	0.0915
1	E	1	-0.9490	-1.0235	-1.0550	0.0315	0.0745
1	E	2	-0.9495	-1.0270	-1.0550	0.0280	0.0775

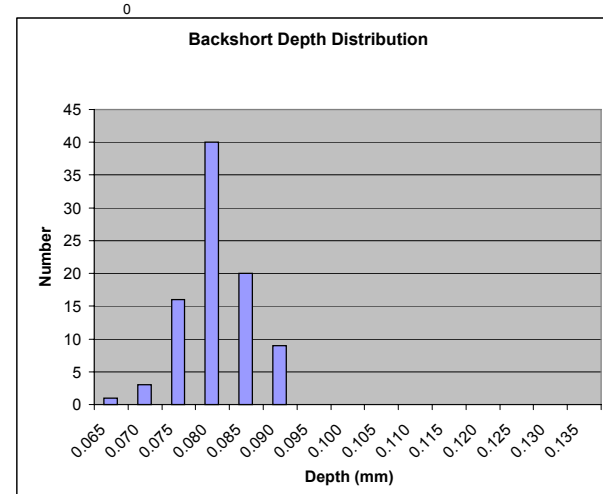

SPIRE Assembly Array/Backshort Assembly Traveller
Revised by A Turner March 5, 2003

AIDS: 243660

Device #	PMW 2.1	PMW BS 3.2
Date	8-Jun-04	
Collected by	A Turner	

Height measurements of Backshort to Detector to NTD chip

a= BS height
b= to web
c= NTD height

Device Thickness Measurements		
Zero at	Measure at	Meas (mm)

Pillar Height Measurements							
Zero at	Row	Pixel	a (mm)	b(mm)	c(mm)	NTD chip (mm)	BS dist (mm)
1	E	3	-0.9505	-1.0300	-1.0615	0.0315	0.0795
1	E	4	-0.9505	-1.0325	-1.0650	0.0325	0.0820
1	E	5	-0.9515	-1.0345	-1.0685	0.0340	0.0830
1	E	6	-0.9515	-1.0355	-1.0665	0.0310	0.0840
1	E	7	-0.9530	-1.0355	-1.0670	0.0315	0.0825
1	E	8	-0.9530	-1.0370	-1.0705	0.0335	0.0840
1	E	9	-0.9530	-1.0380	-1.0685	0.0305	0.0850
1	E	10	-0.9530	-1.0400	-1.0685	0.0285	0.0870
1	E	11	-0.9530	-1.0420	-1.0705	0.0285	0.0890
1	E	12	-0.9520	-1.0430	-1.0730	0.0300	0.0910
1	E	13	-0.9520	-1.0445	-1.0790	0.0345	0.0925
1	T	2		-1.0235	-1.0530		0.0295
1	F	1	-0.9505	-1.0245	-1.0550	0.0305	0.0740
1	F	2	-0.9505	-1.0270	-1.0570	0.0300	0.0765
1	F	3	-0.9510	-1.0300	-1.0590	0.0290	0.0790
1	F	4	-0.9520	-1.0330	-1.0660	0.0330	0.0810
1	F	5	-0.9520	-1.0335	-1.0660	0.0325	0.0815
1	F	6	-0.9520	-1.0350	-1.0665	0.0315	0.0830
1	F	7	-0.9520	-1.0355	-1.0655	0.0300	0.0835
1	F	8	-0.9535	-1.0365	-1.0665	0.0300	0.0830
1	F	9	-0.9535	-1.0385	-1.0645	0.0260	0.0850
1	F	10	-0.9535	-1.0400	-1.0675	0.0275	0.0865
1	F	11	-0.9530	-1.0425	-1.0745	0.0320	0.0895
1	F	12	-0.9525	-1.0440	-1.0685	0.0245	0.0915
1	K	2	-0.9525	-1.0455	-1.0765		
1	G	1	-0.9505	-1.0205	-1.0495	0.0290	0.0700
1	G	2	-0.9510	-1.0230	-1.0550	0.0320	0.0720
1	G	3	-0.9515	-1.0270	-1.0560	0.0290	0.0755
1	G	4	-0.9520	-1.0295	-1.0590	0.0295	0.0775
1	G	5	-0.9520	-1.0305	-1.0580	0.0275	0.0785
1	G	6	-0.9530	-1.0320	-1.0620	0.0300	0.0790
1	G	7	-0.9535	-1.0320	-1.0605	0.0285	0.0785
1	G	8	-0.9540	-1.0335	-1.0615	0.0280	0.0795
1	G	9	-0.9535	-1.0355	-1.0660	0.0305	0.0820
1	G	10	-0.9535	-1.0370	-1.0680	0.0310	0.0835
1	G	11	-0.9535	-1.0395	-1.0705	0.0310	0.0860
1	G	12	-0.9525	-1.0420	-1.0705	0.0285	0.0895
1	G	13	-0.9525	-1.0445	-1.0735	0.0290	0.0920

0

membrane broken

SPIRE Assembly Array/Backshort Assembly Traveller
 Revised by A Turner Jan 12, 2004
 Backshort Distance map

Device	PMW 2.1 and PMW BS 3.2												
Date	8/24/04												
Proc by	A Turner												
AIDS	243660												
A1	A2	A3	A4	A5	A6	A7	A8	A9	A10	A11	A12	A13	
0.0785	0.0805	0.082	0.0815	0.083	0.082	0.0825	0.0825	0.083	0.0845	0.085	0.087	0.0925	
K1	B1	B2	B3	B4	B5	B6	B7	B8	B9	B10	B11	B12	T1
0.0775	0.0775	0.0805	0.081	0.082	0.0835	0.0835	0.084	0.085	0.085	0.087	0.088	0.0895	
C1	C2	C3	C4	C5	C6	C7	C8	C9	C10	C11	C12	C13	
0.077	0.08	0.0815	0.083	0.084	0.0835	0.0835	0.084	0.0855	0.0865	0.088	0.09	0.092	
D1	D2	D3	D4	D5	D6	D7	D8	D9	D10	D11	D12		
0.0775	0.08	0.0825	0.0835	0.0845	0.0835	0.0845	0.0865	0.0875	0.089	0.09	0.0915		
E1	E2	E3	E4	E5	E6	E7	E8	E9	E10	E11	E12	E13	
0.0745	0.0775	0.0795	0.082	0.083	0.084	0.0825	0.084	0.085	0.087	0.089	0.091	0.0925	
T2	F1	F2	F3	F4	F5	F6	F7	F8	F9	F10	F11	F12	K2
	0.074	0.0765	0.079	0.081	0.0815	0.083	0.0835	0.083	0.085	0.0865	0.0895	0.0915	
G1	G2	G3	G4	G5	G6	G7	G8	G9	G10	G11	G12	G13	
0.07	0.072	0.0755	0.0775	0.0785	0.079	0.0785	0.0795	0.082	0.0835	0.086	0.0895	0.092	

BS Dist Criteria (mm)	
Low	0.0810
High	0.1010

Stack Thickness (mm)	
Average	1.0345
max	1.0455
min	1.0205
p-p	0.0250
BS Thickness(mm)	
Average	0.9511
max	0.9540
min	0.9470
p-p	0.0070

BS Distance (mm)	
Average	0.0833
max	0.0925
min	0.0700
p-p	0.0225
NTD Chip Thick(mm)	
Average	0.0305
max	0.0355
min	0.0245
p-p	0.0110

Alignment Measurement Summary
for
PFM PMW BDA
10209800-2 SN012

WARM ALIGNMENT MEASUREMENTS:

Position:

Center of feed horn entrance plane with respect to the alignment pin hole, mounting face and alignment slot as defined in the ICD drawing 10209721 sht. 3 (see Figure 1 below)

$$(x,y,z) = (24.815, -33.866, 34.611) \quad (\text{all distances in mm})$$

Nominal x,y position:

$$(x_{\text{nom}}, y_{\text{nom}}) = (24.687, -33.979)$$

x-y shift from nominal:

$$(dx, dy) = (0.128, 0.113)$$

The z position of the suspended part referenced to the 34.2 mm nominal dimension on ICD pg 2, zone G9:

Measured z dimension:

$$34.162 \text{ mm}$$

Z shift from nominal

$$-0.038 \text{ mm}$$

Rotation:

Feed horn rotation in xy plane (top view, as in ICD, sht. 3)

$$0.28^\circ \text{ counterclockwise}$$

Normal vector to feedhorn entrance plane:

$$(0.00237, 0.00842, 0.99996)$$

which is 0.50° from the z direction.

COLD ALIGNMENT MEASUREMENTS:

(BDA cooled from RmT to approximately 7-8 K)

Shifts on Cooling:

XY Shift of center of 300 mK stage on cooling (with respect to flange alignment pin hole):

$$(dx, dy) = (-0.09, 0.14)$$

300 mK stage rotation in xy plane on cooling (top view):

0.03 degrees CCW

The suspended portion of the BDA shifted approximately .05 mm down in the z axis on cooling, moving closer to the mounting flange. The rotation about the x-axis on cooling was measured as <0.03 degrees, but this angle did not return to the original value on warming to room temperature, so the reliability of this number is in question. We have no information about rotation in the y axis on cooling.

These shifts are not accurate to better than ± 40 microns, and the repeatability over multiple cooldowns is not well known.

Net Result:

xy cold position relative to alignment pin hole:

$$(x, y) = (24.72, -33.73)$$

(this doesn't agree exactly with the sum of the results above due to roundoff)

Rotation of feedhorn relative to xy axes (top view):

0.31 degrees counter-clockwise

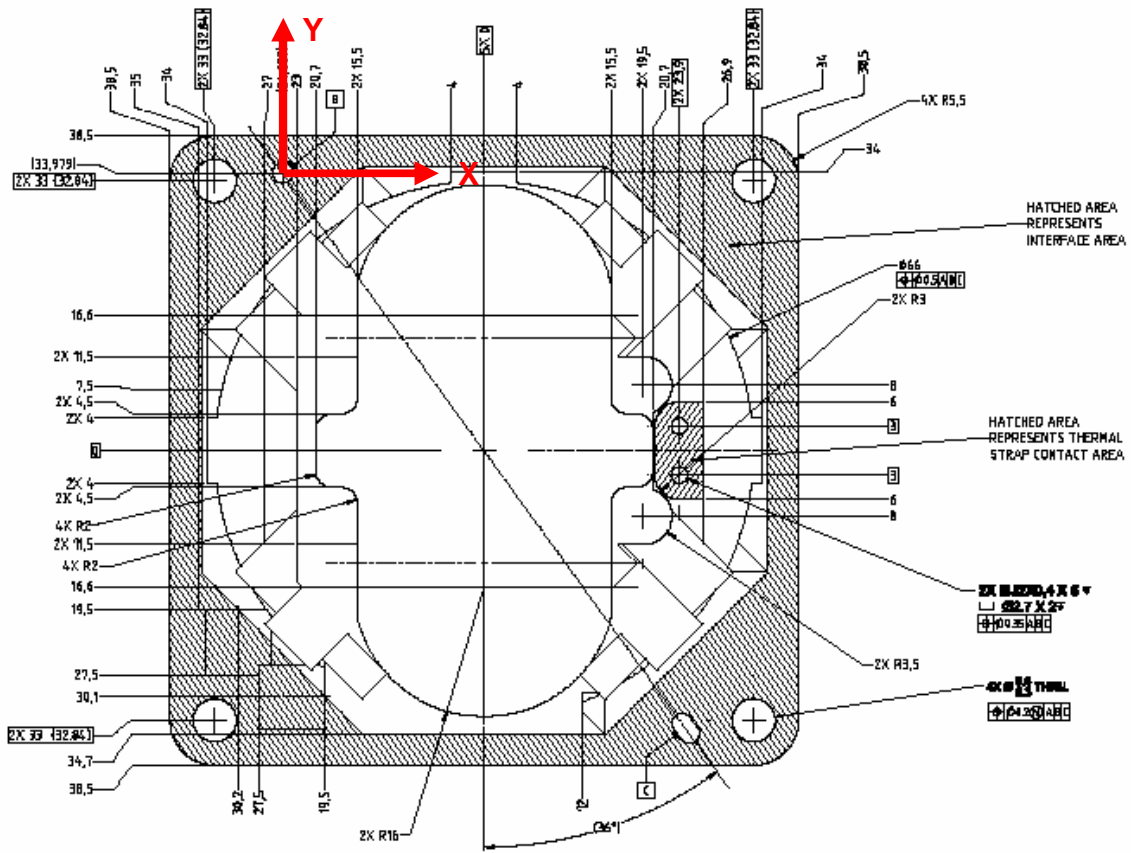

Figure 1 (excerpt from ICD dwg 10209721, with coordinate axes shown)



Advancing Ultra-Precision Manufacturing

Custom Microwave Inc.
940 Boston Avenue
Longmont, CO 80501

CERTIFICATE OF COMPLIANCE

JPL	1256992
CUSTOMER	PURCHASE ORDER NUMBER

4380	10209823 REV X7
INVOICE NUMBER	PART NUMBER(S)

P8991-02	1 EA.
LOT NUMBER(S)/SERIAL	QUANTITY

Custom Microwave, Inc. certifies that all materials and processes used in the manufacturing of supplied parts conforms in all respects to the above mentioned purchase order, specification and/or drawing requirements and that documents are on file to substantiate this and are available for examination. Custom Microwave, Inc. further certifies that no parts supplied against this purchase order contain mercury or have come in contact with mercury or mercury compounds nor do they contain beryllium or beryllium compounds except beryllium copper.

	7/21/04
Authorized Signature Quality Assurance Manager	Date

CMI CAGE CODE: 5Y549

MATERIALS:

COPPER C101 HOUSING: RM#997
BRASS WIRE RM# 1200
SN96 SOLDER: RM#1294

PROCESSES:

COPPER ELECTROFORM CMI COPPER # 3
GOLD PLATE PER MIL-G-45204, TYPE 3, CLASS 1, GRADE A

NCR # 13160 attached



NON CONFORMANCE REPORT	1. NCR #: 13160	2. Pg. 1 of 3
-------------------------------	---------------------------	-------------------------

3. PART #: 10209823	REV. X7	4. PART DESCRIPTION: FEEDHORN - P/MW, BDA	5. PROJ. #: P8991	6. CUSTOMER: JPL
7. SERIAL # OR BATCH # -02	8. VENDOR NAME	9. VEND CERT#	10. VEND P.O #	11. VEND #

8. DETAILS OF NON CONFORMANCE

12. ITEM #	13. DESCRIPTION Dwg Zone, Spec. Para, Ser. no.	14. DISCREPANCY	15. TEAM #	16. QTY	17. DEFECT CODE
1	D-12, // .003 A	.0033	7	1	05D
2	C-12, 2 X R 24.7 +0/-0.2	24.3375	7	1	05D
3	G-12, 10.65 MAX	10.7195	7	1	05D
4	C-12, 4.5 MIN	4.4197	7	1	05D

18. ORIGINATOR: (PRINT & SIGN) TROY GEORGE <i>Troy George</i>	DATE: 7-21-04	19. OPERATION DETECTED AT: 190	20. WORK AREA DETECTED AT: INSPECTION
---	-------------------------	--	---

21. ITEM #	22. OPER #	23. DISPOSITION	24. STAMP/SIGN
1-9		REQUEST USE AS IS	<i>022</i>

25. RTV Qty: -	26. SCRAP Qty: -	27. REWORK Qty: -	28. STANDARD REPAIR Qty: -	29. USE AS IS Qty: 1	30. REPAIR Qty: -
-----------------------	-------------------------	--------------------------	-----------------------------------	-----------------------------	--------------------------

31. CLASSIFICATION CRITICAL <input type="checkbox"/> MAJOR <input type="checkbox"/> MINOR <input checked="" type="checkbox"/>	32. CUSTOMER APPROVAL REQUIRED YES <input checked="" type="checkbox"/> NO <input type="checkbox"/>	33. CORRECTIVE ACTION REQUIRED. YES <input type="checkbox"/> NO <input checked="" type="checkbox"/>
--	---	---

34. Project Leader: <i>[Signature]</i>	DATE: 7/21/04	35. Customer Approval: SEE ATTACHED	DATE: 7-21-04	36. Quality Assurance: <i>[Signature]</i>	DATE: 7-21-04
--	----------------------	--	----------------------	---	----------------------

37. CAUSE:
MACHINING ERROR

38. CAR#:	39. ACTIONEE:	40. ASSIGNED DATE:
-----------	---------------	--------------------

41. CORRECTIVE ACTION:

42. EFFECTIVITY DATE/ (Lot#/S/N)

43. DATE COMPLETED:	44. APPROVED BY:	45. CACODE#:
---------------------	------------------	--------------

Clency Lee-Yow

From: Mark Weilert [Mark.A.Weilert@jpl.nasa.gov]
Sent: Wednesday, July 21, 2004 11:47 AM
To: Clency Lee-Yow
Cc: Martin Herman
Subject: PMW / 823 feedhorn, sn2 discrepancies

Hi Clency

I looked through all the numbers on the 823 feedhorn, and it is ok to finish off and ship.

Mark

Mark Weilert
M/S 79-24
Jet Propulsion Laboratory
4800 Oak Grove Dr.
Pasadena Ca 91109-8099

Mark.A.Weilert@jpl.nasa.gov
office: (818) 354-5060
fax: (818) 393-4878

Any opinions expressed are mine, and do not represent official positions or policies of JPL



NON CONFORMANCE REPORT

1. NCR # :

2. Pg. 2 of
3

3. PART #: 10209823	REV. Y 7	4. PART DESCRIPTION: FEED HORN - P/MW, BDA	5. PROJ. # : P8991	6. CUSTOMER : JPL
7. SERIAL # OR BATCH # -02	8. VENDOR NAME	9. VEND CERT#	10. VEND P.O #	11. VEND #

8. DETAILS OF NON CONFORMANCE

12. ITEM #	13. DESCRIPTION Dwg Zone, Spec. Para, Ser. no.	14. DISCREPANCY	15. TEAM #	16. QTY	17. DEFECT CODE
5	C-12, 4.5 MIN	4.3577	7	1	OSD
6	F-10, Ø3.237/Ø3.223	3.2400 - 3.2729	7	1	OSD
7	C-3, Ø0.04 A B C	.0601 MAX	7	1	OSD
8	C-9, Ø1.61/Ø1.6 THRU	1.6129	7	1	OSD

18. ORIGINATOR: (PRINT & SIGN) _____ DATE: _____

19. OPERATION DETECTED AT: _____

20. WORK AREA DETECTED AT: _____

21. ITEM #	22. OPER #	23. DISPOSITION	24. STAMP/ SIGN

25. RTV Qty:	26. SCRAP Qty:	27. REWORK Qty:	28. STANDARD REPAIR Qty:	29. USE AS IS Qty:	30. REPAIR Qty:
--------------	----------------	-----------------	--------------------------	--------------------	-----------------

31. CLASSIFICATION CRITICAL <input type="checkbox"/> MAJOR <input type="checkbox"/> MINOR <input type="checkbox"/>	32. CUSTOMER APPROVAL REQUIRED YES <input type="checkbox"/> NO <input type="checkbox"/>	33. CORRECTIVE ACTION REQUIRED. YES <input type="checkbox"/> NO <input type="checkbox"/>
---	--	---

34. Project Leader : 	DATE : 7/21/04	35. Customer Approval:	DATE :	36. Quality Assurance : 	DATE : 7/21/04
--	----------------	------------------------	--------	---	----------------

37. CAUSE :

38. CAR#:	39. ACTIONEE :	40. ASSIGNED DATE:
-----------	----------------	--------------------

41. CORRECTIVE ACTION :

42. EFFECTIVITY DATE/ (Lot#/S/N)

43. DATE COMPLETED :	44. APPROVED BY:	45. CACODE#:
----------------------	------------------	--------------



NON CONFORMANCE REPORT	1. NCR # :	2. Pg. 3 of 3
-------------------------------	------------	----------------------

3. PART # : 10209823	REV. X7	4. PART DESCRIPTION : FEEDHORN - P/MW, BDA	5. PROJ. # : P8991	6. CUSTOMER : JPL
7. SERIAL # OR BATCH # -02	8. VENDOR NAME	9. VEND CERT#	10. VEND P.O #	11. VEND #

8. DETAILS OF NON CONFORMANCE

12. ITEM #	13. DESCRIPTION Dwg Zone, Spec. Para, Ser. no.	14. DISCREPANCY	15. TEAM #	16. QTY	17. DEFECT CODE
9	F-4, 1.6 +.01/-0	1.6256	7	1	050

18. ORIGINATOR: (PRINT & SIGN)	DATE:	19. OPERATION DETECTED AT:	20. WORK AREA DETECTED AT:
-----------------------------------	-------	----------------------------	----------------------------

21. ITEM #	22. OPER #	23. DISPOSITION	24. STAMP/ SIGN

25. RTV Qty:	26. SCRAP Qty:	27. REWORK Qty:	28. STANDARD REPAIR Qty:	29. USE AS IS Qty:	30. REPAIR Qty:
--------------	----------------	-----------------	--------------------------	--------------------	-----------------

31. CLASSIFICATION CRITICAL <input type="checkbox"/> MAJOR <input type="checkbox"/> MINOR <input type="checkbox"/>	32. CUSTOMER APPROVAL REQUIRED YES <input type="checkbox"/> NO <input type="checkbox"/>	33. CORRECTIVE ACTION REQUIRED. YES <input type="checkbox"/> NO <input type="checkbox"/>
---	--	---

34. Project Leader : 	DATE : 7/21/04	35. Customer Approval: 	DATE : 7/21/04	36. Quality Assurance : 	DATE
--------------------------	-------------------	----------------------------	-------------------	-----------------------------	------

37. CAUSE :

38. CAR#:	39. ACTIONEE :	40. ASSIGNED DATE:
-----------	----------------	--------------------

41. CORRECTIVE ACTION :

42. EFFECTIVITY DATE/ (Lot#/S/N)

43. DATE COMPLETED :	44. APPROVED BY:	45. CACODE#:
----------------------	------------------	--------------

LARGE DIAMETER REPORT

$\varnothing 3.237 - \varnothing 3.223$

Feedhorn Entrance Diameters
Top View of Feedhorn
(looking down onto feedhorn entrances)
holes are marked with pixel ID and "Circle Number" index to
measurements on following 8 pages.
The origin is at the center of G13

Thermal Strap Side

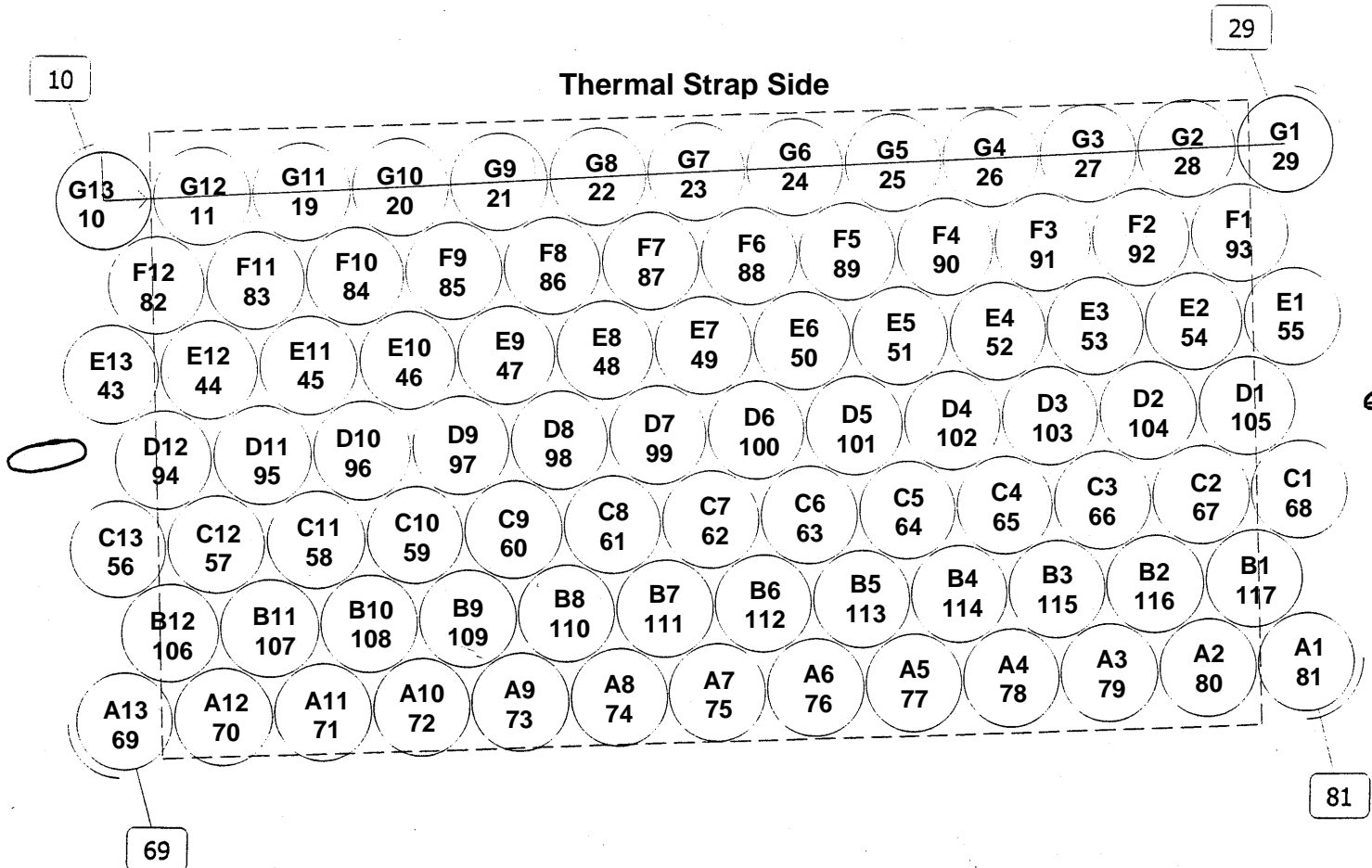

Feature	Actual	Nominal	Plus (+)	Minus (-)	Dev/Nom	Out/Tol
Circle 10	[System 9]					
Center X	0.0076	0.0000			0.0076	
Center Y	-0.0053	0.0000			-0.0053	
Diameter	3.2599	3.2230	0.0140	0.0000	0.0369	0.0229
TP RFS	0.0185		0.0400			
Circle 11	[System 9]					
Center X	3.3515	3.3396			0.0119	
Center Y	-0.0053	0.0000			-0.0053	
Diameter	3.2530	3.2230	0.0140	0.0000	0.0300	0.0160
TP RFS	0.0261		0.0400			
Circle 19	[System 9]					
Center X	6.6998	6.6793			0.0205	
Center Y	-0.0087	0.0000			-0.0087	
Diameter	3.2552	3.2230	0.0140	0.0000	0.0322	0.0182
TP RFS	0.0446		0.0400			0.0046
Circle 20	[System 9]					
Center X	10.0339	10.0189			0.0150	
Center Y	-0.0077	0.0000			-0.0077	
Diameter	3.2536	3.2230	0.0140	0.0000	0.0306	0.0166
TP RFS	0.0337		0.0400			
Circle 21	[System 9]					
Center X	13.3679	13.3586			0.0093	
Center Y	-0.0009	0.0000			-0.0009	
Diameter	3.2517	3.2230	0.0140	0.0000	0.0287	0.0147
TP RFS	0.0186		0.0400			
Circle 22	[System 9]					
Center X	16.7089	16.6983			0.0106	
Center Y	-0.0005	0.0000			-0.0005	
Diameter	3.2457	3.2230	0.0140	0.0000	0.0227	0.0087
TP RFS	0.0213		0.0400			
Circle 23	[System 9]					
Center X	20.0414	20.0379			0.0035	
Center Y	0.0044	0.0000			0.0044	
Diameter	3.2564	3.2230	0.0140	0.0000	0.0334	0.0194
TP RFS	0.0113		0.0400			
Circle 24	[System 9]					
Center X	23.3823	23.3776			0.0047	
Center Y	0.0030	0.0000			0.0030	
Diameter	3.2374	3.2230	0.0140	0.0000	0.0144	0.0004
TP RFS	0.0111		0.0400			
Circle 25	[System 9]					
Center X	26.7257	26.7172			0.0085	
Center Y	-0.0045	0.0000			-0.0045	
Diameter	3.2530	3.2230	0.0140	0.0000	0.0300	0.0160
TP RFS	0.0192		0.0400			
Circle 26	[System 9]					
Center X	30.0671	30.0569			0.0102	
Center Y	-0.0029	0.0000			-0.0029	
Diameter	3.2501	3.2230	0.0140	0.0000	0.0271	0.0131
TP RFS	0.0212		0.0400			
Circle 27	[System 9]					
Center X	33.4020	33.3965			0.0055	
Center Y	-0.0062	0.0000			-0.0062	
Diameter	3.2611	3.2230	0.0140	0.0000	0.0381	0.0241
TP RFS	0.0166		0.0400			

Feature	Actual	Nominal	Plus (+)	Minus (-)	Dev/Nom	Out/Tol
Circle 28	[System 9]				0.0014	
Center X	36.7376	36.7362			-0.0072	
Center Y	-0.0072	0.0000				0.0176
Diameter	3.2546	3.2230	0.0140	0.0000	0.0316	
TP RFS	0.0147		0.0400			
Circle 29	[System 9]				0.0010	
Center X	40.0769	40.0759			-0.0091	
Center Y	-0.0091	0.0000				0.0076
Diameter	3.2446	3.2230	0.0140	0.0000	0.0216	
TP RFS	0.0182		0.0400			
Circle 43	[System 9]				0.0173	
Center X	0.0173	0.0000			-0.0046	
Center Y	-5.7891	-5.7845				0.0075
Diameter	3.2445	3.2230	0.0140	0.0000	0.0215	
TP RFS	0.0358		0.0400			
Circle 44	[System 9]				0.0133	
Center X	3.3529	3.3396			-0.0039	
Center Y	-5.7884	-5.7845				0.0067
Diameter	3.2437	3.2230	0.0140	0.0000	0.0207	
TP RFS	0.0278		0.0400			
Circle 45	[System 9]				0.0108	
Center X	6.6901	6.6793			-0.0085	
Center Y	-5.7930	-5.7845				0.0107
Diameter	3.2477	3.2230	0.0140	0.0000	0.0247	
TP RFS	0.0275		0.0400			
Circle 46	[System 9]				0.0167	
Center X	10.0356	10.0189			0.0012	
Center Y	-5.7833	-5.7845				0.0059
Diameter	3.2429	3.2230	0.0140	0.0000	0.0199	
TP RFS	0.0336		0.0400			
Circle 47	[System 9]				0.0149	
Center X	13.3735	13.3586			-0.0005	
Center Y	-5.7850	-5.7845				0.0166
Diameter	3.2536	3.2230	0.0140	0.0000	0.0306	
TP RFS	0.0299		0.0400			
Circle 48	[System 9]				0.0111	
Center X	16.7094	16.6983			-0.0010	
Center Y	-5.7855	-5.7845				0.0176
Diameter	3.2546	3.2230	0.0140	0.0000	0.0316	
TP RFS	0.0223		0.0400			
Circle 49	[System 9]				0.0064	
Center X	20.0443	20.0379			-0.0082	
Center Y	-5.7927	-5.7845				0.0138
Diameter	3.2508	3.2230	0.0140	0.0000	0.0278	
TP RFS	0.0208		0.0400			
Circle 50	[System 9]				0.0071	
Center X	23.3847	23.3776			-0.0080	
Center Y	-5.7925	-5.7845				0.0257
Diameter	3.2627	3.2230	0.0140	0.0000	0.0397	
TP RFS	0.0214		0.0400			
Circle 51	[System 9]				0.0036	
Center X	26.7208	26.7172			0.0017	
Center Y	-5.7828	-5.7845				0.0172
Diameter	3.2542	3.2230	0.0140	0.0000	0.0312	
TP RFS	0.0081		0.0400			

Feature	Actual	Nominal	Plus (+)	Minus (-)	Dev/Nom	Out/Tol
Circle 52	[System 9]					
Center X	30.0709	30.0569			0.0140	
Center Y	-5.7900	-5.7845			-0.0055	
Diameter	3.2591	3.2230	0.0140	0.0000	0.0361	0.0221
TP RFS	0.0301		0.0400			
Circle 53	[System 9]					
Center X	33.3937	33.3965			-0.0028	
Center Y	-5.7841	-5.7845			0.0004	
Diameter	3.2583	3.2230	0.0140	0.0000	0.0353	0.0213
TP RFS	0.0057		0.0400			
Circle 54	[System 9]					
Center X	36.7285	36.7362			-0.0077	
Center Y	-5.7920	-5.7845			-0.0075	
Diameter	3.2411	3.2230	0.0140	0.0000	0.0181	0.0041
TP RFS	0.0215		0.0400			
Circle 55	[System 9]					
Center X	40.0681	40.0759			-0.0078	
Center Y	-5.7914	-5.7845			-0.0069	
Diameter	3.2587	3.2230	0.0140	0.0000	0.0357	0.0217
TP RFS	0.0207		0.0400			
Circle 56	[System 9]					
Center X	0.0219	0.0000			0.0219	
Center Y	-11.5706	-11.5689			-0.0017	
Diameter	3.2428	3.2230	0.0140	0.0000	0.0198	0.0058
TP RFS	0.0439		0.0400			0.0039
Circle 57	[System 9]					
Center X	3.3525	3.3396			0.0129	
Center Y	-11.5697	-11.5689			-0.0008	
Diameter	3.2556	3.2230	0.0140	0.0000	0.0326	0.0186
TP RFS	0.0259		0.0400			
Circle 58	[System 9]					
Center X	6.6979	6.6793			0.0186	
Center Y	-11.5707	-11.5689			-0.0018	
Diameter	3.2588	3.2230	0.0140	0.0000	0.0358	0.0218
TP RFS	0.0373		0.0400			
Circle 59	[System 9]					
Center X	10.0359	10.0189			0.0170	
Center Y	-11.5752	-11.5689			-0.0063	
Diameter	3.2458	3.2230	0.0140	0.0000	0.0228	0.0088
TP RFS	0.0362		0.0400			
Circle 60	[System 9]					
Center X	13.3705	13.3586			0.0119	
Center Y	-11.5707	-11.5689			-0.0018	
Diameter	3.2666	3.2230	0.0140	0.0000	0.0436	0.0296
TP RFS	0.0240		0.0400			
Circle 61	[System 9]					
Center X	16.7139	16.6983			0.0156	
Center Y	-11.5791	-11.5689			-0.0102	
Diameter	3.2564	3.2230	0.0140	0.0000	0.0334	0.0194
TP RFS	0.0373		0.0400			
Circle 62	[System 9]					
Center X	20.0469	20.0379			0.0090	
Center Y	-11.5734	-11.5689			-0.0045	
Diameter	3.2487	3.2230	0.0140	0.0000	0.0257	0.0117
TP RFS	0.0201		0.0400			

Feature	Actual	Nominal	Plus (+)	Minus (-)	Dev/Nom	Out/Tol
Circle 63	[System 9]				0.0075	
Center X	23.3851	23.3776			-0.0103	
Center Y	-11.5792	-11.5689			0.0296	0.0156
Diameter	3.2526	3.2230	0.0140	0.0000		
TP RFS	0.0255		0.0400			
Circle 64	[System 9]				0.0071	
Center X	26.7243	26.7172			-0.0042	
Center Y	-11.5731	-11.5689			0.0310	0.0170
Diameter	3.2540	3.2230	0.0140	0.0000		
TP RFS	0.0165		0.0400			
Circle 65	[System 9]				0.0019	
Center X	30.0588	30.0569			-0.0067	
Center Y	-11.5756	-11.5689			0.0276	0.0136
Diameter	3.2506	3.2230	0.0140	0.0000		
TP RFS	0.0139		0.0400			
Circle 66	[System 9]				0.0001	
Center X	33.3966	33.3965			-0.0099	
Center Y	-11.5788	-11.5689			0.0326	0.0186
Diameter	3.2556	3.2230	0.0140	0.0000		
TP RFS	0.0197		0.0400			
Circle 67	[System 9]				-0.0010	
Center X	36.7352	36.7362			-0.0043	
Center Y	-11.5732	-11.5689			0.0415	0.0275
Diameter	3.2645	3.2230	0.0140	0.0000		
TP RFS	0.0088		0.0400			
Circle 68	[System 9]				-0.0093	
Center X	40.0666	40.0759			-0.0034	
Center Y	-11.5723	-11.5689			0.0366	0.0226
Diameter	3.2596	3.2230	0.0140	0.0000		
TP RFS	0.0199		0.0400			
Circle 69	[System 9]				0.0169	
Center X	0.0169	0.0000			0.0017	
Center Y	-17.3517	-17.3534			0.0263	0.0123
Diameter	3.2493	3.2230	0.0140	0.0000		
TP RFS	0.0340		0.0400			
Circle 70	[System 9]				0.0173	
Center X	3.3569	3.3396			-0.0060	
Center Y	-17.3594	-17.3534			0.0308	0.0168
Diameter	3.2538	3.2230	0.0140	0.0000		
TP RFS	0.0367		0.0400			
Circle 71	[System 9]				0.0106	
Center X	6.6899	6.6793			-0.0036	
Center Y	-17.3570	-17.3534			0.0314	0.0174
Diameter	3.2544	3.2230	0.0140	0.0000		
TP RFS	0.0225		0.0400			
Circle 72	[System 9]				0.0130	
Center X	10.0319	10.0189			-0.0000	
Center Y	-17.3534	-17.3534			0.0453	0.0313
Diameter	3.2683	3.2230	0.0140	0.0000		
TP RFS	0.0260		0.0400			
Circle 73	[System 9]				0.0098	
Center X	13.3684	13.3586			-0.0030	
Center Y	-17.3564	-17.3534			0.0490	0.0350
Diameter	3.2720	3.2230	0.0140	0.0000		
TP RFS	0.0206		0.0400			

Feature	Actual	Nominal	Plus (+)	Minus (-)	Dev/Nom	Out/Tol
Circle 74	[System 9]				0.0215	
Center X	16.7198	16.6983			-0.0165	
Center Y	-17.3699	-17.3534			0.0422	0.0282
Diameter	3.2652	3.2230	0.0140	0.0000		0.0142
TP RFS	0.0542		0.0400			
Circle 75	[System 9]				0.0019	
Center X	20.0398	20.0379			-0.0150	
Center Y	-17.3684	-17.3534			0.0375	0.0235
Diameter	3.2605	3.2230	0.0140	0.0000		
TP RFS	0.0302		0.0400			
Circle 76	[System 9]				0.0013	
Center X	23.3789	23.3776			-0.0057	
Center Y	-17.3591	-17.3534			0.0374	0.0234
Diameter	3.2604	3.2230	0.0140	0.0000		
TP RFS	0.0118		0.0400			
Circle 77	[System 9]				0.0008	
Center X	26.7180	26.7172			-0.0092	
Center Y	-17.3626	-17.3534			0.0374	0.0234
Diameter	3.2604	3.2230	0.0140	0.0000		
TP RFS	0.0184		0.0400			
Circle 78	[System 9]				0.0004	
Center X	30.0573	30.0569			-0.0086	
Center Y	-17.3620	-17.3534			0.0515	0.0375
Diameter	3.2745	3.2230	0.0140	0.0000		
TP RFS	0.0172		0.0400			
Circle 79	[System 9]				0.0006	
Center X	33.3971	33.3965			-0.0008	
Center Y	-17.3542	-17.3534			0.0436	0.0296
Diameter	3.2666	3.2230	0.0140	0.0000		
TP RFS	0.0020		0.0400			
Circle 80	[System 9]				0.0016	
Center X	36.7378	36.7362			-0.0054	
Center Y	-17.3588	-17.3534			0.0295	0.0155
Diameter	3.2525	3.2230	0.0140	0.0000		
TP RFS	0.0112		0.0400			
Circle 81	[System 9]				-0.0034	
Center X	40.0725	40.0759			-0.0048	
Center Y	-17.3582	-17.3534			0.0376	0.0236
Diameter	3.2606	3.2230	0.0140	0.0000		
TP RFS	0.0118		0.0400			
Circle 82	[System 9]				0.0128	
Center X	1.6826	1.6698			-0.0057	
Center Y	-2.8979	-2.8922			0.0210	0.0070
Diameter	3.2440	3.2230	0.0140	0.0000		
TP RFS	0.0280		0.0400			
Circle 83	[System 9]				0.0159	
Center X	5.0254	5.0095			-0.0062	
Center Y	-2.8984	-2.8922			0.0336	0.0196
Diameter	3.2566	3.2230	0.0140	0.0000		
TP RFS	0.0341		0.0400			
Circle 84	[System 9]				0.0127	
Center X	8.3618	8.3491			-0.0066	
Center Y	-2.8988	-2.8922			0.0317	0.0177
Diameter	3.2547	3.2230	0.0140	0.0000		
TP RFS	0.0286		0.0400			

Feature	Actual	Nominal	Plus (+)	Minus (-)	Dev/Nom	Out/Tol
Circle 85	[System 9]					
Center X	11.7066	11.6888			0.0178	
Center Y	-2.8867	-2.8922			0.0055	
Diameter	3.2525	3.2230	0.0140	0.0000	0.0295	0.0155
TP RFS	0.0372		0.0400			
Circle 86	[System 9]					
Center X	15.0397	15.0284			0.0113	
Center Y	-2.8939	-2.8922			-0.0017	
Diameter	3.2424	3.2230	0.0140	0.0000	0.0194	0.0054
TP RFS	0.0228		0.0400			
Circle 87	[System 9]					
Center X	18.3751	18.3681			0.0070	
Center Y	-2.8982	-2.8922			-0.0060	
Diameter	3.2579	3.2230	0.0140	0.0000	0.0349	0.0209
TP RFS	0.0184		0.0400			
Circle 88	[System 9]					
Center X	21.7189	21.7077			0.0112	
Center Y	-2.8954	-2.8922			-0.0032	
Diameter	3.2545	3.2230	0.0140	0.0000	0.0315	0.0175
TP RFS	0.0233		0.0400			
Circle 89	[System 9]					
Center X	25.0514	25.0474			0.0040	
Center Y	-2.8963	-2.8922			-0.0041	
Diameter	3.2506	3.2230	0.0140	0.0000	0.0276	0.0136
TP RFS	0.0114		0.0400			
Circle 90	[System 9]					
Center X	28.3900	28.3871			0.0029	
Center Y	-2.8925	-2.8922			-0.0003	
Diameter	3.2452	3.2230	0.0140	0.0000	0.0222	0.0082
TP RFS	0.0058		0.0400			
Circle 91	[System 9]					
Center X	31.7235	31.7267			-0.0032	
Center Y	-2.9021	-2.8922			-0.0099	
Diameter	3.2573	3.2230	0.0140	0.0000	0.0343	0.0203
TP RFS	0.0208		0.0400			
Circle 92	[System 9]					
Center X	35.0654	35.0664			-0.0010	
Center Y	-2.8989	-2.8922			-0.0067	
Diameter	3.2501	3.2230	0.0140	0.0000	0.0271	0.0131
TP RFS	0.0135		0.0400			
Circle 93	[System 9]					
Center X	38.4062	38.4060			0.0002	
Center Y	-2.9038	-2.8922			-0.0116	
Diameter	3.2578	3.2230	0.0140	0.0000	0.0348	0.0208
TP RFS	0.0232		0.0400			
Circle 94	[System 9]					
Center X	1.6854	1.6698			0.0156	
Center Y	-8.6835	-8.6767			-0.0068	
Diameter	3.2418	3.2230	0.0140	0.0000	0.0188	0.0048
TP RFS	0.0341		0.0400			
Circle 95	[System 9]					
Center X	5.0234	5.0095			0.0139	
Center Y	-8.6795	-8.6767			-0.0028	
Diameter	3.2463	3.2230	0.0140	0.0000	0.0233	0.0093
TP RFS	0.0284		0.0400			

Feature	Actual	Nominal	Plus (+)	Minus (-)	Dev/Nom	Out/Tol
Circle 96	[System 9]					
Center X	8.3606	8.3491			0.0115	
Center Y	-8.6812	-8.6767			-0.0045	
Diameter	3.2538	3.2230	0.0140	0.0000	0.0308	0.0168
TP RFS	0.0247		0.0400			
Circle 97	[System 9]					
Center X	11.7026	11.6888			0.0138	
Center Y	-8.6791	-8.6767			-0.0024	
Diameter	3.2457	3.2230	0.0140	0.0000	0.0227	0.0087
TP RFS	0.0281		0.0400			
Circle 98	[System 9]					
Center X	15.0425	15.0284			0.0141	
Center Y	-8.6880	-8.6767			-0.0113	
Diameter	3.2498	3.2230	0.0140	0.0000	0.0268	0.0128
TP RFS	0.0362		0.0400			
Circle 99	[System 9]					
Center X	18.3758	18.3681			0.0077	
Center Y	-8.6820	-8.6767			-0.0053	
Diameter	3.2482	3.2230	0.0140	0.0000	0.0252	0.0112
TP RFS	0.0187		0.0400			
Circle 100	[System 9]					
Center X	21.7111	21.7077			0.0034	
Center Y	-8.6802	-8.6767			-0.0035	
Diameter	3.2400	3.2230	0.0140	0.0000	0.0170	0.0030
TP RFS	0.0098		0.0400			
Circle 101	[System 9]					
Center X	25.0474	25.0474			-0.0000	
Center Y	-8.6859	-8.6767			-0.0092	
Diameter	3.2559	3.2230	0.0140	0.0000	0.0329	0.0189
TP RFS	0.0183		0.0400			
Circle 102	[System 9]					
Center X	28.3888	28.3871			0.0017	
Center Y	-8.6754	-8.6767			0.0013	
Diameter	3.2541	3.2230	0.0140	0.0000	0.0311	0.0171
TP RFS	0.0042		0.0400			
Circle 103	[System 9]					
Center X	31.7264	31.7267			-0.0003	
Center Y	-8.6876	-8.6767			-0.0109	
Diameter	3.2501	3.2230	0.0140	0.0000	0.0271	0.0131
TP RFS	0.0219		0.0400			
Circle 104	[System 9]					
Center X	35.0666	35.0664			0.0002	
Center Y	-8.6828	-8.6767			-0.0061	
Diameter	3.2472	3.2230	0.0140	0.0000	0.0242	0.0102
TP RFS	0.0123		0.0400			
Circle 105	[System 9]					
Center X	38.4066	38.4060			0.0006	
Center Y	-8.6874	-8.6767			-0.0107	
Diameter	3.2480	3.2230	0.0140	0.0000	0.0250	0.0110
TP RFS	0.0215		0.0400			
Circle 106	[System 9]					
Center X	1.6810	1.6698			0.0112	
Center Y	-14.4584	-14.4612			0.0028	
Diameter	3.2729	3.2230	0.0140	0.0000	0.0499	0.0359
TP RFS	0.0231		0.0400			

Feature	Actual	Nominal	Plus (+)	Minus (-)	Dev/Nom	Out/Tol
Circle 107	[System 9]					
Center X	5.0236	5.0095			0.0141	
Center Y	-14.4618	-14.4612			-0.0006	
Diameter	3.2663	3.2230	0.0140	0.0000	0.0433	0.0293
TP RFS	0.0283		0.0400			
Circle 108	[System 9]					
Center X	8.3645	8.3491			0.0154	
Center Y	-14.4627	-14.4612			-0.0015	
Diameter	3.2633	3.2230	0.0140	0.0000	0.0403	0.0263
TP RFS	0.0309		0.0400			
Circle 109	[System 9]					
Center X	11.7043	11.6888			0.0155	
Center Y	-14.4652	-14.4612			-0.0040	
Diameter	3.2585	3.2230	0.0140	0.0000	0.0355	0.0215
TP RFS	0.0319		0.0400			
Circle 110	[System 9]					
Center X	15.0339	15.0284			0.0055	
Center Y	-14.4708	-14.4612			-0.0096	
Diameter	3.2564	3.2230	0.0140	0.0000	0.0334	0.0194
TP RFS	0.0221		0.0400			
Circle 111	[System 9]					
Center X	18.3788	18.3681			0.0107	
Center Y	-14.4748	-14.4612			-0.0136	
Diameter	3.2654	3.2230	0.0140	0.0000	0.0424	0.0284
TP RFS	0.0345		0.0400			
Circle 112	[System 9]					
Center X	21.7078	21.7077			0.0001	
Center Y	-14.4595	-14.4612			0.0017	
Diameter	3.2631	3.2230	0.0140	0.0000	0.0401	0.0261
TP RFS	0.0033		0.0400			
Circle 113	[System 9]					
Center X	25.0564	25.0474			0.0090	
Center Y	-14.4708	-14.4612			-0.0096	
Diameter	3.2631	3.2230	0.0140	0.0000	0.0401	0.0261
TP RFS	0.0263		0.0400			
Circle 114	[System 9]					
Center X	28.3875	28.3871			0.0004	
Center Y	-14.4615	-14.4612			-0.0003	
Diameter	3.2554	3.2230	0.0140	0.0000	0.0324	0.0184
TP RFS	0.0009		0.0400			
Circle 115	[System 9]					
Center X	31.7276	31.7267			0.0009	
Center Y	-14.4620	-14.4612			-0.0008	
Diameter	3.2726	3.2230	0.0140	0.0000	0.0496	0.0356
TP RFS	0.0025		0.0400			
Circle 116	[System 9]					
Center X	35.0575	35.0664			-0.0089	
Center Y	-14.4678	-14.4612			-0.0066	
Diameter	3.2563	3.2230	0.0140	0.0000	0.0333	0.0193
TP RFS	0.0222		0.0400			
Circle 117	[System 9]					
Center X	38.4033	38.4060			-0.0027	
Center Y	-14.4634	-14.4612			-0.0022	
Diameter	3.2544	3.2230	0.0140	0.0000	0.0314	0.0174
TP RFS	0.0070		0.0400			

INSPECTION REPORT

$\varnothing .253 / .239$

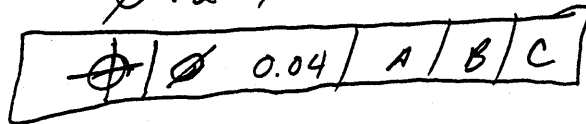

Feedhorn Waveguide Exit Diameters Bottom View of Feedhorn (looking down onto waveguide face)

Holes are marked with pixel ID and "Circle Number" index to measurements on following pages.

The origin is at the center of alignment pin hole to the right of D1

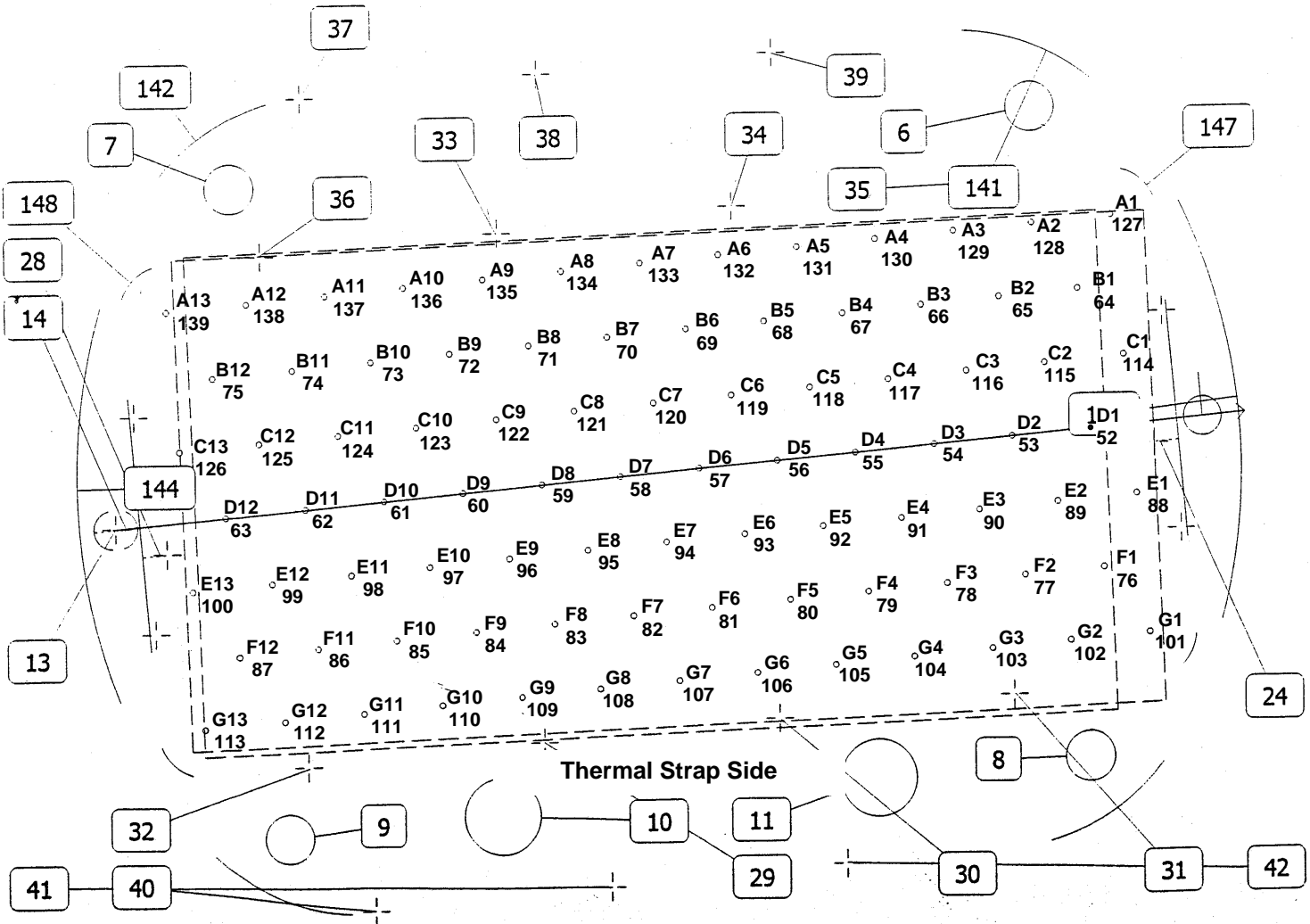

Feature	Actual	Nominal	Plus (+)	Minus (-)	Dev/Nom	Out/Tol
Circle 6	[System 4]					
Center X	-6.0506	-6.0625			0.0119	
Center Y	13.5146	13.5000			0.0146	
Diameter	2.0649	2.0000	0.2500	0.0000	0.0649	
TP MMC	0.0376		0.0500		-0.0273	
Circle 7	[System 4]					
Center X	-40.0544	-40.0625			0.0081	
Center Y	13.4924	13.5000			-0.0076	
Diameter	2.0621	2.0000	0.2500	0.0000	0.0621	
TP MMC	0.0222		0.0500		-0.0400	
Circle 8	[System 4]					
Center X	-6.0603	-6.0625			0.0022	
Center Y	-13.5201	-13.5000			-0.0201	
Diameter	2.0807	2.0000	0.2500	0.0000	0.0807	
TP MMC	0.0404		0.0500		-0.0403	
Circle 9	[System 4]					
Center X	-40.0825	-40.0625			-0.0200	
Center Y	-13.5272	-13.5000			-0.0272	
Diameter	2.0485	2.0000	0.2500	0.0000	0.0485	
TP MMC	0.0676		0.0500		0.0192	
Circle 10	[System 4]					
Center X	-31.0686	-31.0625			-0.0061	
Center Y	-13.5011	-13.5000			-0.0011	
Diameter	3.1977	3.1200	0.0800	0.0000	0.0777	
TP RFS	0.0124		0.3500			
Circle 11	[System 4]					
Center X	-15.0666	-15.0625			-0.0041	
Center Y	-13.5025	-13.5000			-0.0025	
Diameter	3.1992	3.1200	0.0800	0.0000	0.0792	
TP RFS	0.0097		0.3500			
Point 13	[System 4]					
Location X	-46.1355	-46.1250	0.0500	0.0500	-0.0105	
Location Y	0.0027	0.0000	0.0250	0.0250	0.0027	
Distance 14	[System 4]					
Distance X	1.8498	1.8500	0.1000	0.1000	-0.0002	
Distance 24	[System 4]					
Distance X	1.0367	1.0375	1.0000	0.0000	-0.0008	-0.0008
Distance 28	[System 4]					
Distance X	1.0411	1.0375	1.0000	0.0000	0.0036	
Point 29	[System 4]					
Location Y	-10.6346	-10.6500	1.0000	0.0000	0.0154	
Point 30	[System 4]					
Location Y	-10.6300	-10.6500	1.0000	0.0000	0.0200	
Point 31	[System 4]					
Location Y	-10.6417	-10.6500	1.0000	0.0000	0.0083	
Point 32	[System 4]					
Location Y	-10.6385	-10.6500	1.0000	0.0000	0.0115	
Point 33	[System 4]					
Location Y	10.5101	10.6500	0.0000	1.0000	-0.1399	
Point 34	[System 4]					
Location Y	10.6385	10.6500	0.0000	1.0000	-0.0115	

Feature	Actual	Nominal	Plus (+)	Minus (-)	Dev/Nom	Out/Tol
Point 35 Location Y	[System 4] 10.5386	10.6500	0.0000	1.0000	-0.1114	
Point 36 Location Y	[System 4] 10.5604	10.6500	0.0000	1.0000	-0.0896	
Point 37 Location Y	[System 4] 16.9503	17.0000	0.0000	0.2000	-0.0497	
Point 38 Location Y	[System 4] 16.9430	17.0000	0.0000	0.2000	-0.0570	
Point 39 Location Y	[System 4] 16.8266	17.0000	0.0000	0.2000	-0.1734	
Point 40 Location Y	[System 4] -16.8994	-17.0000	0.2000	0.0000	0.1006	
Point 41 Location Y	[System 4] -16.9082	-17.0000	0.2000	0.0000	0.0918	
Point 42 Location Y	[System 4] -16.9177	-17.0000	0.2000	0.0000	0.0823	
Arc 140 Radius	[System 4] 8.9925	9.0000	0.2000	0.2000	-0.0075	
Arc 141 Radius	[System 4] 8.9774	9.0000	0.2000	0.2000	-0.0226	
Arc 142 Radius	[System 4] 9.0606	9.0000	0.2000	0.2000	0.0606	
Arc 143 Radius	[System 4] 8.9196	9.0000	0.2000	0.2000	-0.0804	
Arc 144 Center X	[System 4] -23.3465	-23.0625	0.2000	0.2000	-0.2840	-0.0840
Center Y	0.0247	0.0000	0.1000	0.1000	0.0247	
Radius	24.3375	24.7000	0.0000	0.2000	-0.3625	-0.1625
Arc 145 Center X	[System 4] -22.9657	-23.0625	0.2000	0.2000	0.0968	
Center Y	0.0057	0.0000	0.1000	0.1000	0.0057	
Radius	24.5014	24.7000	0.0000	0.2000	-0.1986	
Arc 146 Radius	[System 4] 1.9285	2.0000	0.1000	0.1000	-0.0715	
Arc 147 Radius	[System 4] 1.9889	2.0000	0.1000	0.1000	-0.0111	
Arc 148 Radius	[System 4] 1.9802	2.0000	0.1000	0.1000	-0.0198	
Arc 149 Radius	[System 4] 2.0084	2.0000	0.1000	0.1000	0.0084	
Circle 52 Center X	[System 49] -4.7597	-4.7613			0.0016	
Center Y	0.0121	0.0000			0.0121	
Diameter	0.2461	0.2390	0.0140	0.0000	0.0071	
Circularity	0.0016					
TP RFS	0.0244		0.0400			

Feature	Actual	Nominal	Plus (+)	Minus (-)	Dev/Nom	Out/Tol
Circle 53	[System 49]					
Center X	-8.1016	-8.1009			-0.0007	
Center Y	0.0094	0.0000			0.0094	
Diameter	0.2473	0.2390	0.0140	0.0000	0.0083	
Circularity	0.0029					
TP RFS	0.0188		0.0400			
Circle 54	[System 49]					
Center X	-11.4385	-11.4406			0.0021	
Center Y	0.0125	0.0000			0.0125	
Diameter	0.2457	0.2390	0.0140	0.0000	0.0067	
Circularity	0.0037					
TP RFS	0.0253		0.0400			
Circle 55	[System 49]					
Center X	-14.7876	-14.7802			-0.0074	
Center Y	0.0116	0.0000			0.0116	
Diameter	0.2460	0.2390	0.0140	0.0000	0.0070	
Circularity	0.0047					
TP RFS	0.0275		0.0400			
Circle 56	[System 49]					
Center X	-18.1185	-18.1199			0.0014	
Center Y	0.0075	0.0000			0.0075	
Diameter	0.2456	0.2390	0.0140	0.0000	0.0066	
Circularity	0.0021					
TP RFS	0.0153		0.0400			
Circle 57	[System 49]					
Center X	-21.4588	-21.4596			0.0008	
Center Y	0.0131	0.0000			0.0131	
Diameter	0.2464	0.2390	0.0140	0.0000	0.0074	
Circularity	0.0031					
TP RFS	0.0262		0.0400			
Circle 58	[System 49]					
Center X	-24.7901	-24.7992			0.0091	
Center Y	0.0137	0.0000			0.0137	
Diameter	0.2458	0.2390	0.0140	0.0000	0.0068	
Circularity	0.0048					
TP RFS	0.0329		0.0400			
Circle 59	[System 49]					
Center X	-28.1315	-28.1389			0.0074	
Center Y	0.0179	0.0000			0.0179	
Diameter	0.2445	0.2390	0.0140	0.0000	0.0055	
Circularity	0.0026					
TP RFS	0.0387		0.0400			
Circle 60	[System 49]					
Center X	-31.4694	-31.4785			0.0091	
Center Y	0.0195	0.0000			0.0195	
Diameter	0.2445	0.2390	0.0140	0.0000	0.0055	
Circularity	0.0027					
TP RFS	0.0431		0.0400			0.0031
Circle 61	[System 49]					
Center X	-34.8125	-34.8182			0.0057	
Center Y	0.0197	0.0000			0.0197	
Diameter	0.2453	0.2390	0.0140	0.0000	0.0063	
Circularity	0.0062					
TP RFS	0.0410		0.0400			0.0010

Feature	Actual	Nominal	Plus (+)	Minus (-)	Dev/Nom	Out/Tol
Circle 62	[System 49]					
Center X	-38.1465	-38.1578			0.0113	
Center Y	0.0248	0.0000			0.0248	
Diameter	0.2423	0.2390	0.0140	0.0000	0.0033	
Circularity	0.0025					
TP RFS	0.0545		0.0400			0.0145
Circle 63	[System 49]					
Center X	-41.4812	-41.4975			0.0163	
Center Y	0.0140	0.0000			0.0140	
Diameter	0.2431	0.2390	0.0140	0.0000	0.0041	
Circularity	0.0041					
TP RFS	0.0429		0.0400			0.0029
Circle 64	[System 49]					
Center X	-4.7652	-4.7613			-0.0039	
Center Y	5.7832	5.7845			-0.0013	
Diameter	0.2432	0.2390	0.0140	0.0000	0.0042	
Circularity	0.0046					
TP RFS	0.0081		0.0400			
Circle 65	[System 49]					
Center X	-8.1086	-8.1009			-0.0077	
Center Y	5.7910	5.7845			0.0065	
Diameter	0.2459	0.2390	0.0140	0.0000	0.0069	
Circularity	0.0034					
TP RFS	0.0201		0.0400			
Circle 66	[System 49]					
Center X	-11.4425	-11.4406			-0.0019	
Center Y	5.7879	5.7845			0.0034	
Diameter	0.2460	0.2390	0.0140	0.0000	0.0070	
Circularity	0.0045					
TP RFS	0.0078		0.0400			
Circle 67	[System 49]					
Center X	-14.7762	-14.7802			0.0040	
Center Y	5.7816	5.7845			-0.0029	
Diameter	0.2443	0.2390	0.0140	0.0000	0.0053	
Circularity	0.0042					
TP RFS	0.0098		0.0400			
Circle 68	[System 49]					
Center X	-18.1235	-18.1199			-0.0036	
Center Y	5.7846	5.7845			0.0001	
Diameter	0.2435	0.2390	0.0140	0.0000	0.0045	
Circularity	0.0117					
TP RFS	0.0073		0.0400			
Circle 69	[System 49]					
Center X	-21.4594	-21.4596			0.0002	
Center Y	5.7930	5.7845			0.0085	
Diameter	0.2437	0.2390	0.0140	0.0000	0.0047	
Circularity	0.0032					
TP RFS	0.0170		0.0400			
Circle 70	[System 49]					
Center X	-24.7934	-24.7992			0.0058	
Center Y	5.7955	5.7845			0.0110	
Diameter	0.2425	0.2390	0.0140	0.0000	0.0035	
Circularity	0.0026					
TP RFS	0.0248		0.0400			

Feature	Actual	Nominal	Plus (+)	Minus (-)	Dev/Nom	Out/Tol
Circle 71	[System 49]					
Center X	-28.1300	-28.1389			0.0089	
Center Y	5.7952	5.7845			0.0107	
Diameter	0.2445	0.2390	0.0140	0.0000	0.0055	
Circularity	0.0029					
TP RFS	0.0279		0.0400			
Circle 72	[System 49]					
Center X	-31.4689	-31.4785			0.0096	
Center Y	5.7965	5.7845			0.0120	
Diameter	0.2419	0.2390	0.0140	0.0000	0.0029	
Circularity	0.0060					
TP RFS	0.0307		0.0400			
Circle 73	[System 49]					
Center X	-34.8119	-34.8182			0.0063	
Center Y	5.7963	5.7845			0.0118	
Diameter	0.2418	0.2390	0.0140	0.0000	0.0028	
Circularity	0.0031					
TP RFS	0.0268		0.0400			
Circle 74	[System 49]					
Center X	-38.1429	-38.1578			0.0149	
Center Y	5.7915	5.7845			0.0070	
Diameter	0.2407	0.2390	0.0140	0.0000	0.0017	
Circularity	0.0026					
TP RFS	0.0328		0.0400			
Circle 75	[System 49]					
Center X	-41.4892	-41.4975			0.0083	
Center Y	5.7969	5.7845			0.0124	
Diameter	0.2448	0.2390	0.0140	0.0000	0.0058	
Circularity	0.0045					
TP RFS	0.0299		0.0400			
Circle 76	[System 49]					
Center X	-4.7639	-4.7613			-0.0026	
Center Y	-5.7737	-5.7845			0.0108	
Diameter	0.2463	0.2390	0.0140	0.0000	0.0073	
Circularity	0.0047					
TP RFS	0.0221		0.0400			
Circle 77	[System 49]					
Center X	-8.1003	-8.1009			0.0006	
Center Y	-5.7678	-5.7845			0.0167	
Diameter	0.2464	0.2390	0.0140	0.0000	0.0074	
Circularity	0.0033					
TP RFS	0.0335		0.0400			
Circle 78	[System 49]					
Center X	-11.4421	-11.4406			-0.0015	
Center Y	-5.7656	-5.7845			0.0189	
Diameter	0.2464	0.2390	0.0140	0.0000	0.0074	
Circularity	0.0023					
TP RFS	0.0379		0.0400			
Circle 79	[System 49]					
Center X	-14.7861	-14.7802			-0.0059	
Center Y	-5.7668	-5.7845			0.0177	
Diameter	0.2453	0.2390	0.0140	0.0000	0.0063	
Circularity	0.0034					
TP RFS	0.0374		0.0400			

Feature	Actual	Nominal	Plus (+)	Minus (-)	Dev/Nom	Out/Tol
Circle 80	[System 49]					
Center X	-18.1182	-18.1199			0.0017	
Center Y	-5.7714	-5.7845			0.0131	
Diameter	0.2436	0.2390	0.0140	0.0000	0.0046	
Circularity	0.0060					
TP RFS	0.0263		0.0400			
Circle 81	[System 49]					
Center X	-21.4579	-21.4596			0.0017	
Center Y	-5.7692	-5.7845			0.0153	
Diameter	0.2427	0.2390	0.0140	0.0000	0.0037	
Circularity	0.0024					
TP RFS	0.0307		0.0400			
Circle 82	[System 49]					
Center X	-24.7933	-24.7992			0.0059	
Center Y	-5.7677	-5.7845			0.0168	
Diameter	0.2467	0.2390	0.0140	0.0000	0.0077	
Circularity	0.0030					
TP RFS	0.0355		0.0400			
Circle 83	[System 49]					
Center X	-28.1291	-28.1389			0.0098	
Center Y	-5.7657	-5.7845			0.0188	
Diameter	0.2409	0.2390	0.0140	0.0000	0.0019	
Circularity	0.0063					
TP RFS	0.0425		0.0400			0.0025
Circle 84	[System 49]					
Center X	-31.4714	-31.4785			0.0071	
Center Y	-5.7670	-5.7845			0.0175	
Diameter	0.2430	0.2390	0.0140	0.0000	0.0040	
Circularity	0.0033					
TP RFS	0.0377		0.0400			
Circle 85	[System 49]					
Center X	-34.8188	-34.8182			-0.0006	
Center Y	-5.7650	-5.7845			0.0195	
Diameter	0.2470	0.2390	0.0140	0.0000	0.0080	
Circularity	0.0029					
TP RFS	0.0391		0.0400			
Circle 86	[System 49]					
Center X	-38.1533	-38.1578			0.0045	
Center Y	-5.7689	-5.7845			0.0156	
Diameter	0.2412	0.2390	0.0140	0.0000	0.0022	
Circularity	0.0033					
TP RFS	0.0325		0.0400			
Circle 87	[System 49]					
Center X	-41.4861	-41.4975			0.0114	
Center Y	-5.7694	-5.7845			0.0151	
Diameter	0.2421	0.2390	0.0140	0.0000	0.0031	
Circularity	0.0031					
TP RFS	0.0379		0.0400			
Circle 88	[System 49]					
Center X	-3.0963	-3.0914			-0.0049	
Center Y	-2.8821	-2.8922			0.0101	
Diameter	0.2463	0.2390	0.0140	0.0000	0.0073	
Circularity	0.0042					
TP RFS	0.0224		0.0400			

Feature	Actual	Nominal	Plus (+)	Minus (-)	Dev/Nom	Out/Tol
Circle 89	[System 49]					
Center X	-6.4369	-6.4311			-0.0058	
Center Y	-2.8817	-2.8922			0.0105	
Diameter	0.2471	0.2390	0.0140	0.0000	0.0081	
Circularity	0.0019					
TP RFS	0.0241		0.0400			
Circle 90	[System 49]					
Center X	-9.7735	-9.7708			-0.0027	
Center Y	-2.8844	-2.8922			0.0078	
Diameter	0.2433	0.2390	0.0140	0.0000	0.0043	
Circularity	0.0020					
TP RFS	0.0165		0.0400			
Circle 91	[System 49]					
Center X	-13.1098	-13.1104			0.0006	
Center Y	-2.8825	-2.8922			0.0097	
Diameter	0.2431	0.2390	0.0140	0.0000	0.0041	
Circularity	0.0029					
TP RFS	0.0195		0.0400			
Circle 92	[System 49]					
Center X	-16.4428	-16.4501			0.0073	
Center Y	-2.8810	-2.8922			0.0112	
Diameter	0.2456	0.2390	0.0140	0.0000	0.0066	
Circularity	0.0052					
TP RFS	0.0268		0.0400			
Circle 93	[System 49]					
Center X	-19.7827	-19.7897			0.0070	
Center Y	-2.8793	-2.8922			0.0129	
Diameter	0.2455	0.2390	0.0140	0.0000	0.0065	
Circularity	0.0041					
TP RFS	0.0293		0.0400			
Circle 94	[System 49]					
Center X	-23.1235	-23.1294			0.0059	
Center Y	-2.8725	-2.8922			0.0197	
Diameter	0.2441	0.2390	0.0140	0.0000	0.0051	
Circularity	0.0023					
TP RFS	0.0412		0.0400			0.0012
Circle 95	[System 49]					
Center X	-26.4583	-26.4690			0.0107	
Center Y	-2.8723	-2.8922			0.0199	
Diameter	0.2434	0.2390	0.0140	0.0000	0.0044	
Circularity	0.0023					
TP RFS	0.0452		0.0400			0.0052
Circle 96	[System 49]					
Center X	-29.7937	-29.8087			0.0150	
Center Y	-2.8750	-2.8922			0.0172	
Diameter	0.2433	0.2390	0.0140	0.0000	0.0043	
Circularity	0.0025					
TP RFS	0.0456		0.0400			0.0056
Circle 97	[System 49]					
Center X	-33.1352	-33.1484			0.0132	
Center Y	-2.8774	-2.8922			0.0148	
Diameter	0.2420	0.2390	0.0140	0.0000	0.0030	
Circularity	0.0026					
TP RFS	0.0396		0.0400			

Feature	Actual	Nominal	Plus (+)	Minus (-)	Dev/Nom	Out/Tol
Circle 98	[System 49]					
Center X	-36.4863	-36.4880			0.0017	
Center Y	-2.8660	-2.8922			0.0262	
Diameter	0.2498	0.2390	0.0140	0.0000	0.0108	
Circularity	0.0018					
TP RFS	0.0526		0.0400			0.0126
Circle 99	[System 49]					
Center X	-39.8236	-39.8277			0.0041	
Center Y	-2.8730	-2.8922			0.0192	
Diameter	0.2405	0.2390	0.0140	0.0000	0.0015	
Circularity	0.0028					
TP RFS	0.0392		0.0400			
Circle 100	[System 49]					
Center X	-43.1520	-43.1673			0.0153	
Center Y	-2.8775	-2.8922			0.0147	
Diameter	0.2459	0.2390	0.0140	0.0000	0.0069	
Circularity	0.0020					
TP RFS	0.0424		0.0400			0.0024
Circle 101	[System 49]					
Center X	-3.0968	-3.0914			-0.0054	
Center Y	-8.6663	-8.6767			0.0104	
Diameter	0.2461	0.2390	0.0140	0.0000	0.0071	
Circularity	0.0034					
TP RFS	0.0235		0.0400			
Circle 102	[System 49]					
Center X	-6.4390	-6.4311			-0.0079	
Center Y	-8.6660	-8.6767			0.0107	
Diameter	0.2459	0.2390	0.0140	0.0000	0.0069	
Circularity	0.0020					
TP RFS	0.0267		0.0400			
Circle 103	[System 49]					
Center X	-9.7705	-9.7708			0.0003	
Center Y	-8.6592	-8.6767			0.0175	
Diameter	0.2442	0.2390	0.0140	0.0000	0.0052	
Circularity	0.0042					
TP RFS	0.0350		0.0400			
Circle 104	[System 49]					
Center X	-13.1142	-13.1104			-0.0038	
Center Y	-8.6561	-8.6767			0.0206	
Diameter	0.2440	0.2390	0.0140	0.0000	0.0050	
Circularity	0.0071					
TP RFS	0.0418		0.0400			0.0018
Circle 105	[System 49]					
Center X	-16.4522	-16.4501			-0.0021	
Center Y	-8.6555	-8.6767			0.0212	
Diameter	0.2417	0.2390	0.0140	0.0000	0.0027	
Circularity	0.0043					
TP RFS	0.0427		0.0400			0.0027
Circle 106	[System 49]					
Center X	-19.7884	-19.7897			0.0013	
Center Y	-8.6543	-8.6767			0.0224	
Diameter	0.2432	0.2390	0.0140	0.0000	0.0042	
Circularity	0.0040					
TP RFS	0.0449		0.0400			0.0049

Feature	Actual	Nominal	Plus (+)	Minus (-)	Dev/Nom	Out/Tol
Circle 107	[System 49]					
Center X	-23.1290	-23.1294			0.0004	
Center Y	-8.6538	-8.6767			0.0229	
Diameter	0.2478	0.2390	0.0140	0.0000	0.0088	
Circularity	0.0022					
TP RFS	0.0458		0.0400			0.0058
Circle 108	[System 49]					
Center X	-26.4672	-26.4690			0.0018	
Center Y	-8.6582	-8.6767			0.0185	
Diameter	0.2456	0.2390	0.0140	0.0000	0.0066	
Circularity	0.0014					
TP RFS	0.0372		0.0400			
Circle 109	[System 49]					
Center X	-29.8056	-29.8087			0.0031	
Center Y	-8.6557	-8.6767			0.0210	
Diameter	0.2411	0.2390	0.0140	0.0000	0.0021	
Circularity	0.0027					
TP RFS	0.0424		0.0400			0.0024
Circle 110	[System 49]					
Center X	-33.1452	-33.1484			0.0032	
Center Y	-8.6468	-8.6767			0.0299	
Diameter	0.2428	0.2390	0.0140	0.0000	0.0038	
Circularity	0.0105					
TP RFS	0.0601		0.0400			0.0201
Circle 111	[System 49]					
Center X	-36.4866	-36.4880			0.0014	
Center Y	-8.6503	-8.6767			0.0264	
Diameter	0.2459	0.2390	0.0140	0.0000	0.0069	
Circularity	0.0066					
TP RFS	0.0530		0.0400			0.0130
Circle 112	[System 49]					
Center X	-39.8240	-39.8277			0.0037	
Center Y	-8.6490	-8.6767			0.0277	
Diameter	0.2455	0.2390	0.0140	0.0000	0.0065	
Circularity	0.0064					
TP RFS	0.0559		0.0400			0.0159
Circle 113	[System 49]					
Center X	-43.1637	-43.1673			0.0036	
Center Y	-8.6509	-8.6767			0.0258	
Diameter	0.2442	0.2390	0.0140	0.0000	0.0052	
Circularity	0.0086					
TP RFS	0.0522		0.0400			0.0122
Circle 114	[System 49]					
Center X	-3.0961	-3.0914			-0.0047	
Center Y	2.9005	2.8922			0.0083	
Diameter	0.2444	0.2390	0.0140	0.0000	0.0054	
Circularity	0.0067					
TP RFS	0.0190		0.0400			
Circle 115	[System 49]					
Center X	-6.4370	-6.4311			-0.0059	
Center Y	2.9028	2.8922			0.0106	
Diameter	0.2443	0.2390	0.0140	0.0000	0.0053	
Circularity	0.0009					
TP RFS	0.0243		0.0400			

Feature	Actual	Nominal	Plus (+)	Minus (-)	Dev/Nom	Out/Tol
Circle 116	[System 49]					
Center X	-9.7704	-9.7708			0.0004	
Center Y	2.9008	2.8922			0.0086	
Diameter	0.2468	0.2390	0.0140	0.0000	0.0078	
Circularity	0.0033					
TP RFS	0.0172		0.0400			
Circle 117	[System 49]					
Center X	-13.1093	-13.1104			0.0011	
Center Y	2.8947	2.8922			0.0025	
Diameter	0.2438	0.2390	0.0140	0.0000	0.0048	
Circularity	0.0068					
TP RFS	0.0056		0.0400			
Circle 118	[System 49]					
Center X	-16.4491	-16.4501			0.0010	
Center Y	2.8920	2.8922			-0.0002	
Diameter	0.2462	0.2390	0.0140	0.0000	0.0072	
Circularity	0.0027					
TP RFS	0.0021		0.0400			
Circle 119	[System 49]					
Center X	-19.7851	-19.7897			0.0046	
Center Y	2.8960	2.8922			0.0038	
Diameter	0.2463	0.2390	0.0140	0.0000	0.0073	
Circularity	0.0008					
TP RFS	0.0120		0.0400			
Circle 120	[System 49]					
Center X	-23.1188	-23.1294			0.0106	
Center Y	2.9017	2.8922			0.0095	
Diameter	0.2440	0.2390	0.0140	0.0000	0.0050	
Circularity	0.0036					
TP RFS	0.0285		0.0400			
Circle 121	[System 49]					
Center X	-26.4604	-26.4690			0.0086	
Center Y	2.9094	2.8922			0.0172	
Diameter	0.2449	0.2390	0.0140	0.0000	0.0059	
Circularity	0.0021					
TP RFS	0.0385		0.0400			
Circle 122	[System 49]					
Center X	-29.7944	-29.8087			0.0143	
Center Y	2.9028	2.8922			0.0106	
Diameter	0.2439	0.2390	0.0140	0.0000	0.0049	
Circularity	0.0030					
TP RFS	0.0355		0.0400			
Circle 123	[System 49]					
Center X	-33.1405	-33.1484			0.0079	
Center Y	2.9119	2.8922			0.0197	
Diameter	0.2441	0.2390	0.0140	0.0000	0.0051	
Circularity	0.0023					
TP RFS	0.0425		0.0400			0.0025
Circle 124	[System 49]					
Center X	-36.4783	-36.4880			0.0097	
Center Y	2.9152	2.8922			0.0230	
Diameter	0.2439	0.2390	0.0140	0.0000	0.0049	
Circularity	0.0032					
TP RFS	0.0499		0.0400			0.0099

Feature	Actual	Nominal	Plus (+)	Minus (-)	Dev/Nom	Out/Tol
Circle 125	[System 49]					
Center X	-39.8150	-39.8277			0.0127	
Center Y	2.9134	2.8922			0.0212	
Diameter	0.2425	0.2390	0.0140	0.0000	0.0035	
Circularity	0.0032					
TP RFS	0.0494		0.0400			0.0094
Circle 126	[System 49]					
Center X	-43.1519	-43.1673			0.0154	
Center Y	2.9074	2.8922			0.0152	
Diameter	0.2438	0.2390	0.0140	0.0000	0.0048	
Circularity	0.0051					
TP RFS	0.0432		0.0400			0.0032
Circle 127	[System 49]					
Center X	-3.0866	-3.0914			0.0048	
Center Y	8.6748	8.6767			-0.0019	
Diameter	0.2449	0.2390	0.0140	0.0000	0.0059	
Circularity	0.0082					
TP RFS	0.0103		0.0400			
Circle 128	[System 49]					
Center X	-6.4304	-6.4311			0.0007	
Center Y	8.6787	8.6767			0.0020	
Diameter	0.2443	0.2390	0.0140	0.0000	0.0053	
Circularity	0.0026					
TP RFS	0.0043		0.0400			
Circle 129	[System 49]					
Center X	-9.7714	-9.7708			-0.0006	
Center Y	8.6793	8.6767			0.0026	
Diameter	0.2438	0.2390	0.0140	0.0000	0.0048	
Circularity	0.0027					
TP RFS	0.0053		0.0400			
Circle 130	[System 49]					
Center X	-13.1049	-13.1104			0.0055	
Center Y	8.6747	8.6767			-0.0020	
Diameter	0.2490	0.2390	0.0140	0.0000	0.0100	
Circularity	0.0051					
TP RFS	0.0116		0.0400			
Circle 131	[System 49]					
Center X	-16.4445	-16.4501			0.0056	
Center Y	8.6764	8.6767			-0.0003	
Diameter	0.2460	0.2390	0.0140	0.0000	0.0070	
Circularity	0.0098					
TP RFS	0.0111		0.0400			
Circle 132	[System 49]					
Center X	-19.7909	-19.7897			-0.0012	
Center Y	8.6800	8.6767			0.0033	
Diameter	0.2467	0.2390	0.0140	0.0000	0.0077	
Circularity	0.0016					
TP RFS	0.0070		0.0400			
Circle 133	[System 49]					
Center X	-23.1258	-23.1294			0.0036	
Center Y	8.6810	8.6767			0.0043	
Diameter	0.2419	0.2390	0.0140	0.0000	0.0029	
Circularity	0.0062					
TP RFS	0.0112		0.0400			

Feature	Actual	Nominal	Plus (+)	Minus (-)	Dev/Nom	Out/Tol
Circle 134	[System 49]					
Center X	-26.4590	-26.4690			0.0100	
Center Y	8.6755	8.6767			-0.0012	
Diameter	0.2444	0.2390	0.0140	0.0000	0.0054	
Circularity	0.0026					
TP RFS	0.0201		0.0400			
Circle 135	[System 49]					
Center X	-29.7977	-29.8087			0.0110	
Center Y	8.6787	8.6767			0.0020	
Diameter	0.2460	0.2390	0.0140	0.0000	0.0070	
Circularity	0.0034					
TP RFS	0.0223		0.0400			
Circle 136	[System 49]					
Center X	-33.1413	-33.1484			0.0071	
Center Y	8.6792	8.6767			0.0025	
Diameter	0.2471	0.2390	0.0140	0.0000	0.0081	
Circularity	0.0028					
TP RFS	0.0151		0.0400			
Circle 137	[System 49]					
Center X	-36.4775	-36.4880			0.0105	
Center Y	8.6849	8.6767			0.0082	
Diameter	0.2439	0.2390	0.0140	0.0000	0.0049	
Circularity	0.0070					
TP RFS	0.0266		0.0400			
Circle 138	[System 49]					
Center X	-39.8120	-39.8277			0.0157	
Center Y	8.6841	8.6767			0.0074	
Diameter	0.2428	0.2390	0.0140	0.0000	0.0038	
Circularity	0.0044					
TP RFS	0.0347		0.0400			
Circle 139	[System 49]					
Center X	-43.1600	-43.1673			0.0073	
Center Y	8.6826	8.6767			0.0059	
Diameter	0.2416	0.2390	0.0140	0.0000	0.0026	
Circularity	0.0126					
TP RFS	0.0187		0.0400			

CUSTOMER 19698		SHIP DATE 11/21/00 SHP		GROSS WEIGHT 86		QUOTE 18-757538-3		OF 3		PACKING LIST	
BILL TO: CUSTOM MICROWAVE INC				WORK ORDER 331844 **		ORDER DATE 11/17/00 ORD		TEST RESULTS			
SHIP TO CUSTOM MICROWAVE INC 01 40 BOSTON AVENUE LONGMONT CO 80501						DELIVERY DATE 11/27/00 DEL		SHIP BRANCH 03-CLE		SELL BRANCH 18-STL	
CUSTOMER P.O. NUMBER 11725		TERRITORY 03		ENTRY ID 04JDF		THYSSEN COPPER AND BRASS SALES AIN PLASTICS TMX		5755 GRANT AVENUE CLEVELAND OH 44105-5635			
BUYER MIKE		INSIDE SALES JOHN D. FITZPATRICK		04JDF							
BUYER TELEPHONE (303) 651-0707		INSIDE SALES TELEPHONE (847) 490-9870 239									
SHIP VIA		SHIPPING STATUS									
INTERNAL		COMPLETE X		PARTIAL		CANCEL		CUSTOMER SIGNATURE: DATE:			
TO CUSTOMER COMMON/FRT-		FOB ORIG				QUANTITY		ORDERED		SHIPPED	
BILL OF LADING		FREIGHT STATUS PPD				INVENTORY		69.92 LB		70.00	
PART DESCRIPTION		185966-9				BILLING		1.00 PC		1.00	
CR COPPER PLATE C11000 1-1/2 CUT SAW 12" (+.063,-0) X 12" (+.063,-0) Test Results Attn to: QA Department.						WAREHOUSE		1.00 PC			
						PACKED WITH OTHER GOODS					
						FINISHED GOODS LOCATION					
FULL		SCRAP		FILLED BY GIL		PACKED BY		Q/A AUDIT			
CUSTOMER RECEIVING HOURS								MAXIMUM SKID WEIGHT			
LOADING INSTRUCTIONS								MAXIMUM BUNDLE WEIGHT			
BOXES	BARS	CASES	CUSHP	PKGS	SKIDS	BOLS	TUBES	CTNS	FLAT	COILS	
					1						
SPECIAL INSTRUCTIONS											
INSPECTION RECORD											

TEST RESULTS -----
CERTIFICATE OF COMPLIANCE

We hereby certify that mercury or any of its compounds are not used in the processing and distribution of our products. We hereby certify that the material above complies with the following specifications: ASTM-B152-97A

33565 1.00 PC REVERECOP 0862732 00288201
TAG NUMBER QUANTITY UNIT VENDOR VENDOR PO HEAT/LOT

GARY W. STAMM

- General Manager: CLEVELAND

PRINTED 11/17/00 12:50 AM

CONTROL NO 00073

REVERE COPPER PRODUCTS, INC.

ADDRESS CATHY ST. THOMAS
 ONE REVERE PARK
 ROME, NY 13440-5561

WANTED



OPT 11

PAGE 1

1

REVERE NO. 74450

CUSTOMER DATE		CUSTOMER ORDER NUMBER						
04/18/2000		862732						
CUSTOMER CODE	DIV	SALESMAN	IND. CODE	CL	KS	TAX	TO	
148035004	RM	21		3	1		0	

 * CERTIFICATE OF TEST *

SOLD TO
 TMX/COPPER AND BRASS SALES
 ATTN: ACCOUNTS PAYABLE
 400 RENAISSANCE CENTER - SUITE 1700
 DETROIT MI 48243

SHIP TO
 TMX/COPPER AND BRASS SALES
 5755 GRANT AVENUE
 CLEVELAND OH 44105

02772 REVERE C11000 CR CU PLATE
 TO ASTM B-152

The goods described herein were produced in compliance with all applicable requirements of sections 6, 7 and 12 of the Fair Labor Standards Act, as amended, and of regulations and orders of the United States Department of Labor issued under section 14 thereof.

1.500" X 36.5" X 144.5"

FOB	MILL	PREPAID
VIA		
MARK*	185966-9	

NET WEIGHT - 7727 CUST PART#

ITEM NO.	DESCRIPTION	QTY. ORD.	CASE NO.	NO. OF PCS.	GROSS WT.	TARE	NET WT.	HEAT NO.
	CHEMICAL ANALYSIS							

HEAT#/LOT CU
 00287001 99.98%
 00288201 99.99%
 CU INCLUDES- +Ag

997

PHYSICAL ANALYSIS

HEAT#/LOT	HARDNESS	TENSILE	COND
	RF	KSI	XIACS
00287001	79	34.5	98.5
00288201	80	33.5	98.3

Date 11-21-00
 Customer CUSTOM MICROWAVE
 These Tests Are For Material Shipped On
 Your Order 11725
 From Copper And Brass Sales, Inc.
 INV/WO 331844
 WGT _____ PCS _____
Tom M. Maxwell cc

WE CERTIFY THAT THE FOREGOING RESULTS ARE CORRECT AND THAT THIS MATERIAL HAS BEEN PROCESSED, INSPECTED, AND TESTED IN COMPLIANCE WITH THE REQUIREMENTS OF YOUR PURCHASE ORDER AND SPECIFICATIONS. THIS MATERIAL HAS NOT COME IN CONTACT WITH FREE MERCURY DURING THE MANUFACTURING PROCESS.

RORY MONTGOMERY LABORATORY MANAGER

PART/COMP CODE SIGNATURE ON FILE TRACKING LIST

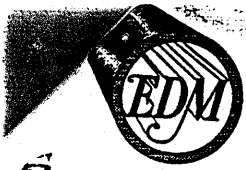

EDM Supplies, Inc.

SHIPPER

9806 Everest Street
 Downey, CA 90242-3199
 Phone: 562-803-6563
 Fax: 562-803-4281

Sales Order Number
 Shipper Number
 Ship Date
 Page

250913
 06/28/02
 2
 1

S 103884
 O CUSTOM MICROWAVE
 L 940 BOSTON AVE
 D LONGMONT CO 80501

B 103884
 L CUSTOM MICROWAVE
 L 940 BOSTON AVE
 L LONGMONT CO 80501

T
O

T
O

FOB: DOWNEY

Terms: NET 30

Freight: PREPAID AND ADD

Customer's PO: 12557

Resale No:

LI#	Order/Qty	UM	Part/Description	Units/Pkg	Ship Qty	Lot Number
1	10	EA	C22-023 .023 DIA. X 12 PBR Rm 1200		5	0
2	10	EA	C22-024 .024 DIA. X 12 PBR Rm 1201		10	0
5	10	EA	C22-027 .027 DIA. X 12 PBR Rm 1204 *****CERTIFICATIONS***** WE HEREBY CERTIFY THIS MATERIAL TO BE PRECISION BRASS ROD ALLOY 260		4	0

SIGNED: *Dan Jongsma*

ORDERED BY DAN JONGSMA

Via: UPS GRND PPB

Waybill No:

SHIP TO: CUSTOM MICROWAVE
 940 BOSTON AVE
 LONGMONT CO 80501

EIS Florida
 1524 West 14th Street Suite 106
 TEMPE AZ 85281
 USA



Packing List # 3325511
 Cust. Phone: 3036510707
 Page: 1 / 1

Sold To: CUSTOM MICROVAPE
 940 BOSTON AVENUE
 LONGHART CO 30501
 USA

Ship To: CUSTOM MICROVAPE
 940 BOSTON AVENUE
 LONGHART CO 30501
 USA

RM-1294

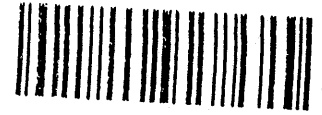

Date: 06/13/03 11:40:35
 Print: 06/13/03 11:40:35
 Sales Order #: 16511107

CUSTOMER ORDER NO 13019		PACKING LIST NO. 3325511		ORDER DATE 06/13/03	CUSTOMER NO. 10498	SALES SUBJECT: Robin Grillo		PCS.	WT.	BILL OF LADING 3325511
SHIP VIA FEDEX PPD & CHG		SALESMAN		ORDERED BY	SHIP DATE 06/13/03	SALESMAN 364		PICKED BY		DATE
CATALOG	COLOR	DESCRIPTION	U / M	QUANTITY ORDERED	QUANTITY SHIPPED	QUANTITY BACK ORDERED				
NOTE: ITEMS NOT BACKORDERED OR DO NOT SHIP WITHOUT CERTIFICATE OF ANALYSIS										
23068		96.3/493.7, SOLID UREA, .031 DIA, 1 LB		2.00	2.00	0.00				
MATERIALS INCLUDED IN THIS SHIPMENT ARE THOSE SPECIFIED ON THE PURCHASE ORDER. ALL SPECIFICATIONS AND PROPERTIES OF THE MATERIAL ARE DETERMINED BY THE MANUFACTURER.										
Authorized Signature / Title:		Scott Booth / Shipper								
Lot/Batch Number (MFG DATE)		31110 / 5/8/03			Shelf Life (Date of Exp) N/A					

THIS SALE IS SUBJECT TO ALL CONDITIONS AND PROVISIONS APPEARING ON THE REVERSE HEREOF

Kester

Pm-1294

Northrop Grumman Corporation
Kester
515 E. Touhy Avenue
Des Plaines, Illinois 60018

Telephone: (847) 297-1600
Fax: (847) 390-9338

CERTIFICATE OF ANALYSIS

ORDER NUMBER:: N/A
CUSTOMER PO:: N/A
LOT NUMBER: 311910

PRODUCT: Sn96.3Ag3.7 Solid Wire

TEST	UNITS	RESULT	MIN SPEC	MAX SPEC
Tin	wt%	BALANCE	Balance	Balance
Lead	wt%	0.0342		0.200
Antimony	wt%	0.0215		0.500
Copper	wt%	0.0044		0.080
Gold	wt%	0.0001		0.050
Aluminum	wt%	0.0001		0.005
Cadmium	wt%	0.0001		0.002
Zinc	wt%	0.0004		0.003
Silver	wt%	3.66	3.50	3.90
Bismuth	wt%	0.0023		0.100
Arsenic	wt%	0.0020		0.030
Iron	wt%	0.0021		0.020
Indium	wt%	0.0040		0.100
Nickel	wt%	0.0002		0.010

We certify that this product conforms to all product specification requirements.
The inspection and test data is indicated above.

This document is computer generated and does not require a signature



SPIRE - 300mK PMW-PFM filter stack

End Item Data Package (EIDP)

SPIRE - 300mK PMW-PFM filter stack

SPIRE Ref.: SPIRE-UCF-
Cardiff Ref.: HSO-CDF-EIDP-057 Issue 1.0
8 January 2004

Prepared by: Peter Hargrave

Approved by: Carole Tucker

Distribution list

JPL	James Bock	RAL	Eric Sawyer
	Hien Nguyen		Eric Clark
	Martin Herman		Judy Long
	Mark Weilert		Bruce Swinyard
Cardiff	Carole Tucker	LAM	Kjetil Dohlen
	Peter Ade		
	Matt Griffin		
	Ian Walker		

Change Record

Issue	Section	Date	Changes

Table of contents

Section	Contents	Req.	Comments
1	Shipping Documents	X	
2	Transportation, Packing, Handling & Integration Procedures	X	
3	Certificate of Conformance / Delivery Review Board MoM Ai-Lists	X	
4	Qualification Status List / Test Matrix	X	
5	Top Level Drawings (inc. Family Tree)	X	
6	Interface Drawings	X	
7	Functional, Block & Mechanical Drawings	X	
8	Electrical Circuit Drawings		
9	As Built Parts List	X	
10	Serialised Components List		
11	List of Waivers		
12	Copies of Waivers		
13	Operational Manual		
14	Historical Record	X	
15	Logbook / Diary of Events	X	
16	Operating Time / Cycle Record	X	
17	Connector Mating Record		
18	Age Sensitive Items Record		
19	Pressure Vessel History / Test Record		
20	Calibration Data Record	X	
21	Temporary Installation Record	X	
22	Open Work / Deferred Work / Open Tests	X	
23	List of Non-Conformance Reports	X	
24	Copies of Non-Conformance Reports	X	
25	Test Reports	X	
26	Proof Load Certificates		
27	Reference List of EIDP's		

	(Lower Level / Associated)		
28	Mass Records / Power Budget	X	
29	Cleanliness Statement	X	
30	Other Useful Information	X	

SECTION 01 - Shipping Documents

SECTION 02 - Transportation, Packing, Handling & Integration Procedures

**This package contains flight hardware.
To be opened only by authorised SPIRE personnel in clean room conditions.**

Do not touch filter surface.

Handle only by Aluminium frame.

To be integrated to SPIRE flight model PMW BDA according to JPL procedure.

Hand over to JPL Cognisant Engineer – Mark Weilert

Mark Weilert
M/S 79-24
Jet Propulsion Laboratory
4800 Oak Grove Dr.
Pasadena Ca 91109-8099

Mark.A.Weilert@jpl.nasa.gov
office: (818) 354-5060
fax: (818) 393-4878

SECTION 03 - Certificate of Conformance

Cardiff University Astronomy Instrumentation Group hereby certifies that the following equipment,		
Spacecraft / Project:	Herschel	
Instrument:	SPIRE	
Model:	PFM	
Subsystem:	300mK PMW filter stack	
Serial No:	FILT-PFM-240	
As described in this End Item Data Package: HSO-CDF-EIDP-057		
Complies with the requirements set out in: SPIRE-RAL-PRJ-000034		
Responsible Authority		Signature
Cardiff Filter Management	Prof P.A.R.Ade	
	Dr C.E.Tucker	
Cardiff Product Assurance	Dr I.Walker	
Cardiff SPIRE Management	Dr P.Hargrave	

SECTION 04 - Qualification Status List / Compliance Matrix

Test	Status	Test Institute
	PFM-PMW - FILT-PFM-240	
Spectral behaviour - Near-band transmission	Tested at component and assembly level. Compliant.	UWC
Spectral behaviour - out-of-band blocking, at $\lambda < 15\mu\text{m}$	Open test. Off-cuts to be tested once facility commissioned	UWC
Dimension and tolerances to specification	Compliant	UWC
Filter flatness	Not applicable	UWC
Inspection for surface defects	Passed	UWC
Mass	Compliant	
Thermal cycling (5 cycles 300K-77K-300K)	Passed	UWC
Cold vibration	Not tested	RAL
Environmental condition - Vacuum $3 \times 10^{-1} \text{mBar}$	Passed	UWC
Differential pressure (a pumping-out rate of 10mB/sec)	Passed	UWC
Pre-bake out (not exceeding 80°C)	Passed	UWC
Outgassing	Test not performed. All materials used within ESA / NASA specifications	
Cleanliness checks, by visual inspection.	Passed	UWC
Degradation due to high energy radiation.	Not tested	

SECTION 05 - Top Level Drawings (Inc. Family Tree)

TOP LEVEL DRAWING LIST

Drawing No.	Title
FILT-CQM/PFM-200-03.001	300mK Filter Assembly

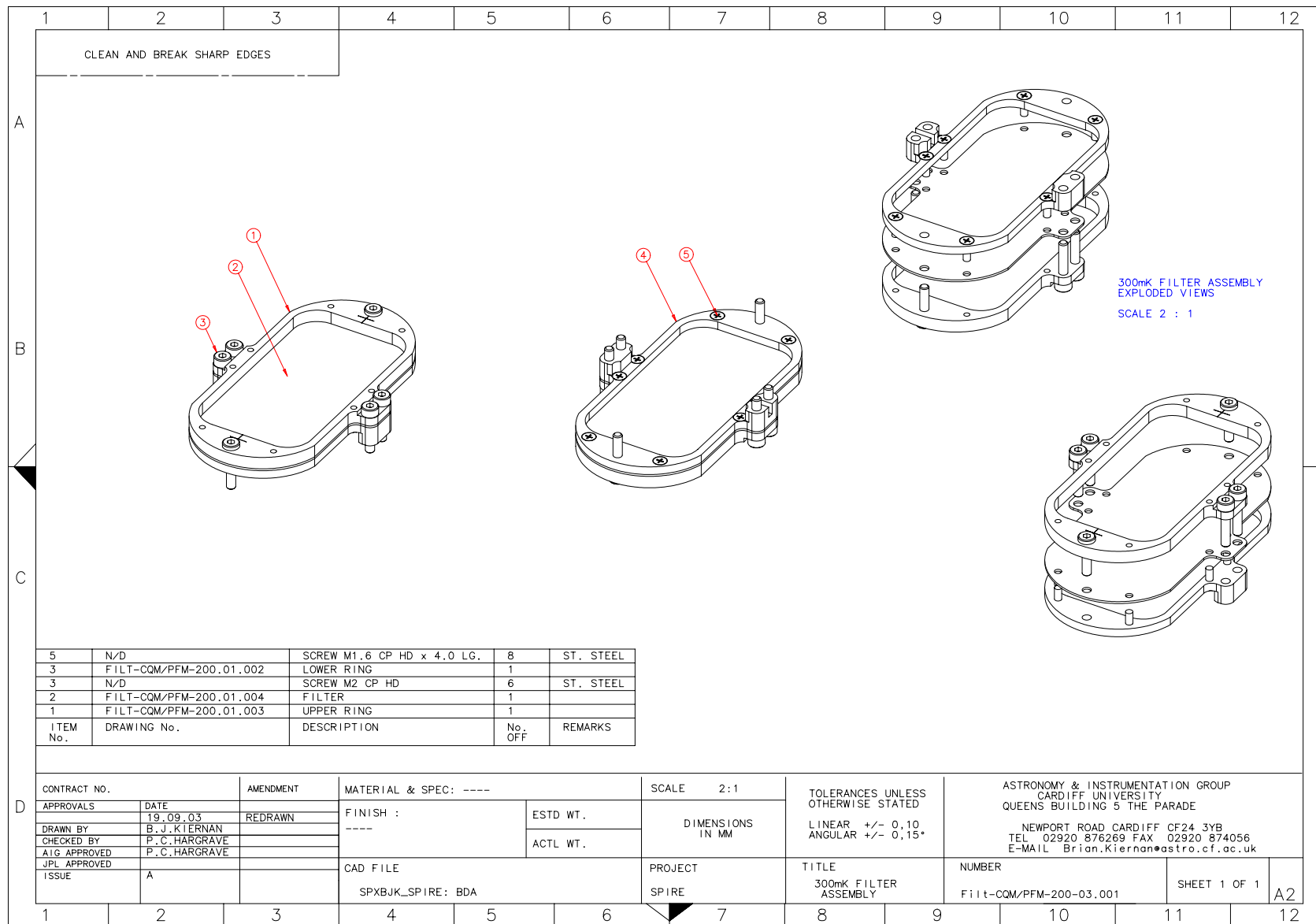

Figure 1 300mK filter stack assembly

SECTION 06 - Interface Drawings

INTERFACE DRAWING LIST

Drawing No.	Title
FILT-CQM/PFM-200	300mK Filter ICD

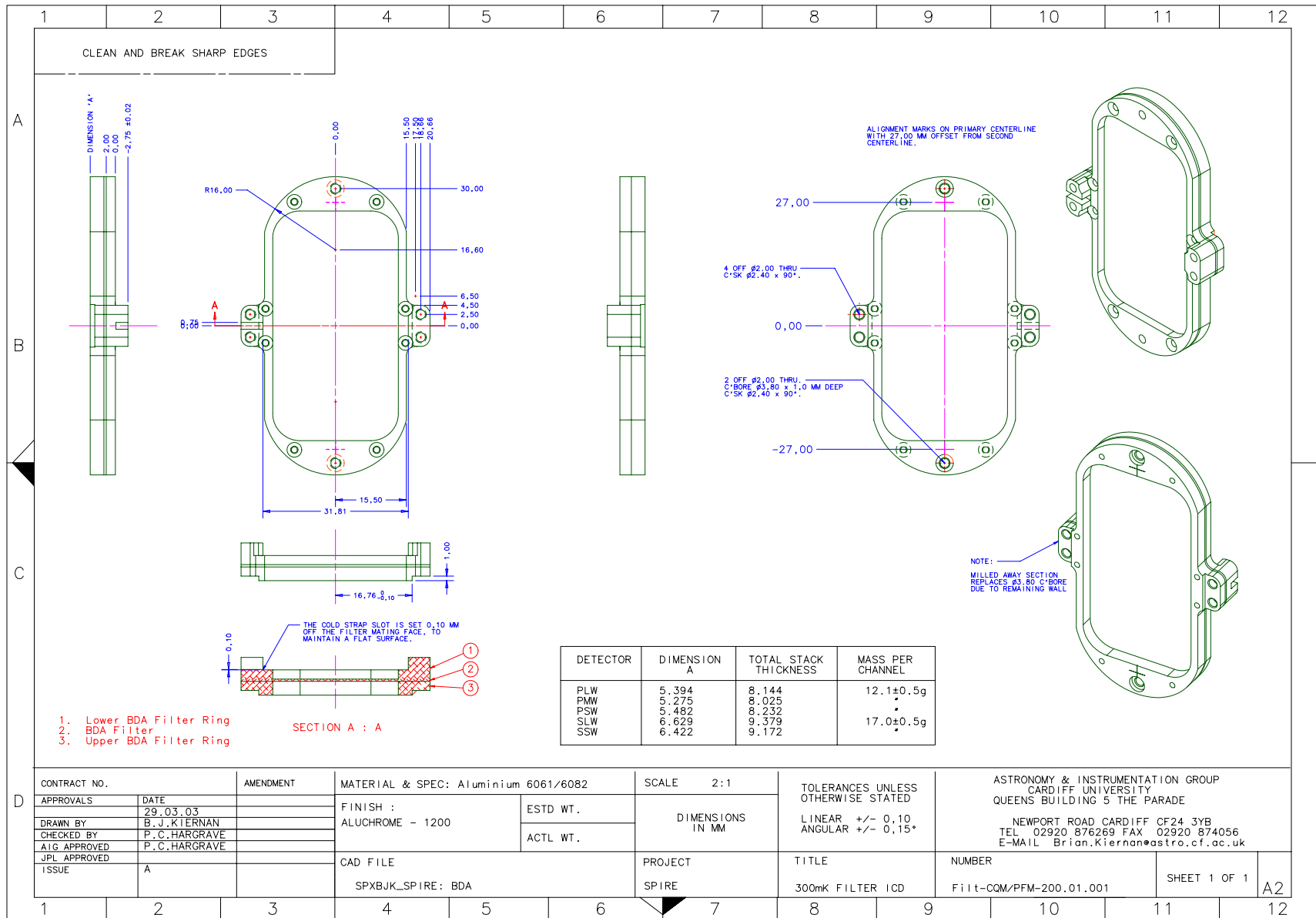

Figure 2 Interface drawing for 300mK filters

SECTION 07 - Functional, Block & Mechanical Drawings

Component drawings are given in this section. Also shown, for illustration purposes, are details of the mounting of the HDPE lens for each filter stack assembly.

FUNCTIONAL & BLOCK DRAWING LIST

Drawing No.	Title

MECHANICAL COMPONENT DRAWING LIST

Drawing No.	Title
FILT-CQM/PFM-200-01-004	300mK Filter
FILT-CQM/PFM-200-01-003	300mK Filter Upper Ring
FILT-CQM/PFM-200-01-002	300mK Filter Lower Ring

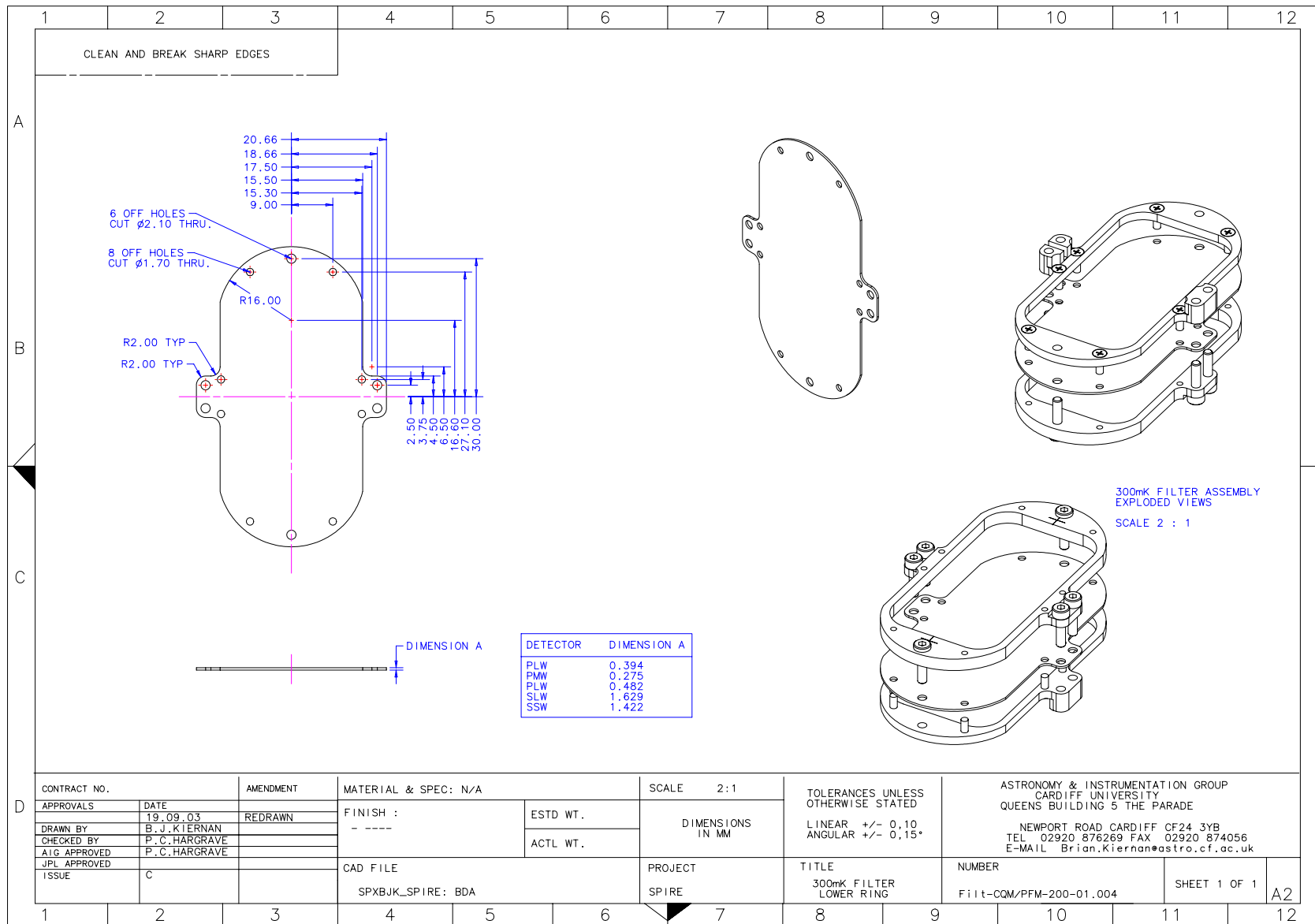

Figure 3 300mK Filter

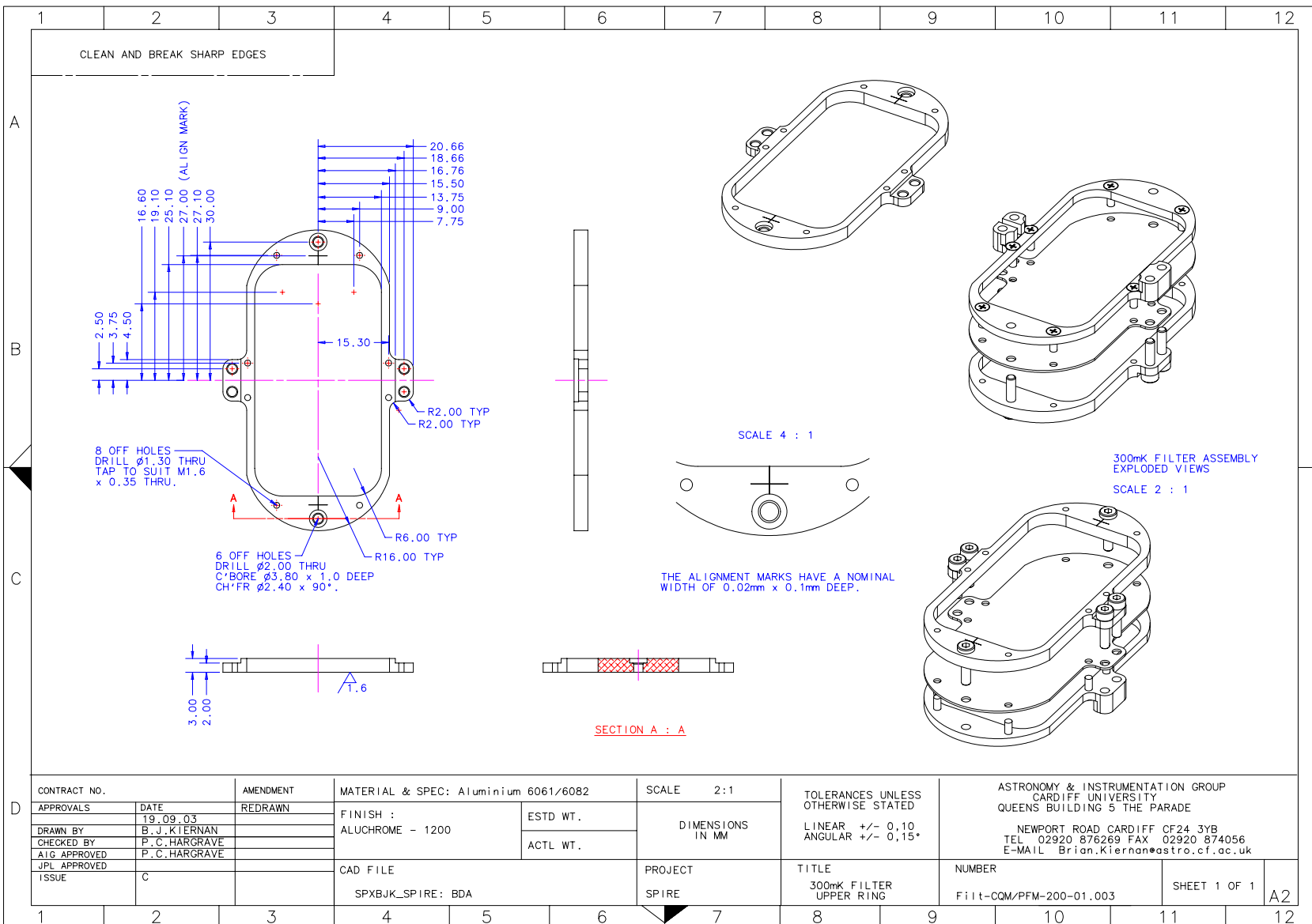

Figure 4 300mK Filter Upper Ring

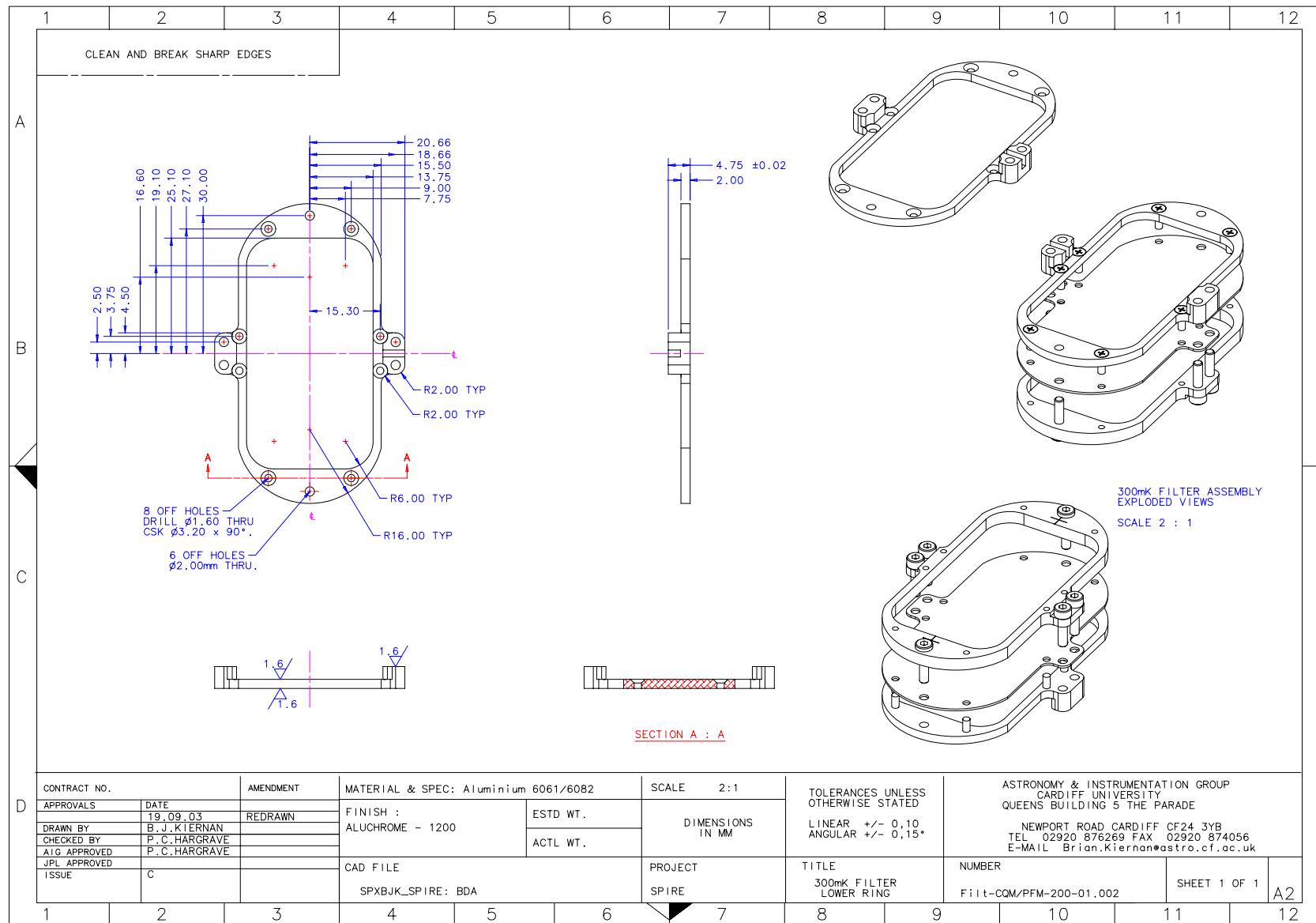

Figure 5 300mK Filter Lower Ring

SECTION 09 - As Built Configuration Items Status List

Item	Reference	Location	Notes
Filter drawings and manufacturing files		\\Darkstar\Astroworld\Projects\SPIRE\Cardiff_workpackages\Configured_documents\Filters\Drawings\300MK-filter-CQM-PFM.doc	
Material certificates of conformance		Available at Cardiff for inspection	
FILT-PFM-240 Spectroscopic test data PMW-PFM assembly		\\Darkstar\Astroworld\Projects\SPIRE\Cardiff_workpackages\Configured_documents\Issued\Data\FILT-PFM-240_PMW_assembly_January2004.xls	

Part number	Description	Details
FILT-PFM-240	PFM PMW FILTER ASSEMBLY	
FILT-PFM-241	PMW PFM lower filter ring	Aluminium-6082 – Aluchrom 1200 coated
FILT-PFM-242	PMW-PFM upper filter ring	Aluminium-6082 – Aluchrom 1200 coated
FILT-PFM-243	PFIL4M – PFM – B734 filter	43cm ⁻¹ (232.6μm) LPE blocking filter

SECTION 11 - List of Waivers

SECTION 12 - Copies of Waivers

SECTION 13 - Operations Manual

SECTION 14 - Historical Record

The following table contains *brief* historical details of the manufacture, assembly and testing of the PFM 300mK PMW filter assembly, including the levels of environmental cleanliness.

A *full* historical record of every stage of manufacture for each individual grid integral to the final mounted filter is traceable at UWC, in both hard copy log-book format and on a Microsoft Access database.

Filter PFIL4M

Date	Action	UWC Test reference
10/10/03	Filter B734 manufactured in class 1000 clean room	
13/10/03	Filter B734 spectroscopically tested in the range 3-40cm ⁻¹	T0198r7
14/10/03	Filter B734 spectroscopically tested in the range 10-140cm ⁻¹	T0199r43
19/12/03	Filter B488 thermally shocked 5 times between 300K and 77K	THERM 0132
19/12/03	Filter B734 cut to PFIL4M drawing	Process HC1
6/1/04	Filter PFIL4M spectroscopically tested in the range 0-145cm ⁻¹ at three locations over area	T0247r22, T0247r16, T0247R19
7/1/04	Filter PFIL4M mounted in PFM-PMW stack	
7/1/04	PFM-PMW stack spectroscopically tested in the range 20-650cm ⁻¹	T0248r4
7/1/04	PFM-PMW stack thermally cycled 300K-77K-300K	THERM 0133
7/1/04	PFM-PMW stack spectroscopically tested in the range 10-145cm ⁻¹	T0248r13
7/1/04	PFM-PMW stack baked for 17hrs at 350K	THERM 0134
8/1/04	PFM-PMW stack spectroscopically tested in the range 0-145cm ⁻¹ at three locations over area	T0250r4, T0250r7, T0250r13,
8/1/04	PFM-SLW stack final clean, 24Hr bake-out at 350K	
12/1/04	PFM-SLW packed in class 1000 clean room & shipped to JPL	

SECTION 15 - Logbook / Diary of Events

Not provided – available from subsystem provider upon request.

SECTION 16 - Operating Time / Cycle Record

SECTION 20 - Calibration Data Record

The recommended total stack transmission for the PMW channel to be used for calibration purposes is indicated in this section, with traces shown for the ranges 3-650cm⁻¹, 20-100cm⁻¹, and 15-40cm⁻¹.

These are the measured transmission spectra prior to final cleaning and packing.

The raw data is stored in the file \\Darkstar\Astroworld\Projects\SPIRE\Cardiff_workpackages\Configured_documents\Issued\Data\FILT-PFM-240_PMW_assembly_January2004.xls (Microsoft Excel workbook). This file is available from Cardiff, and is under configuration control on Livelink (managed by RAL).

Transmission spectrum of SPIRE PFM PFIL4M from 3-650cm-1

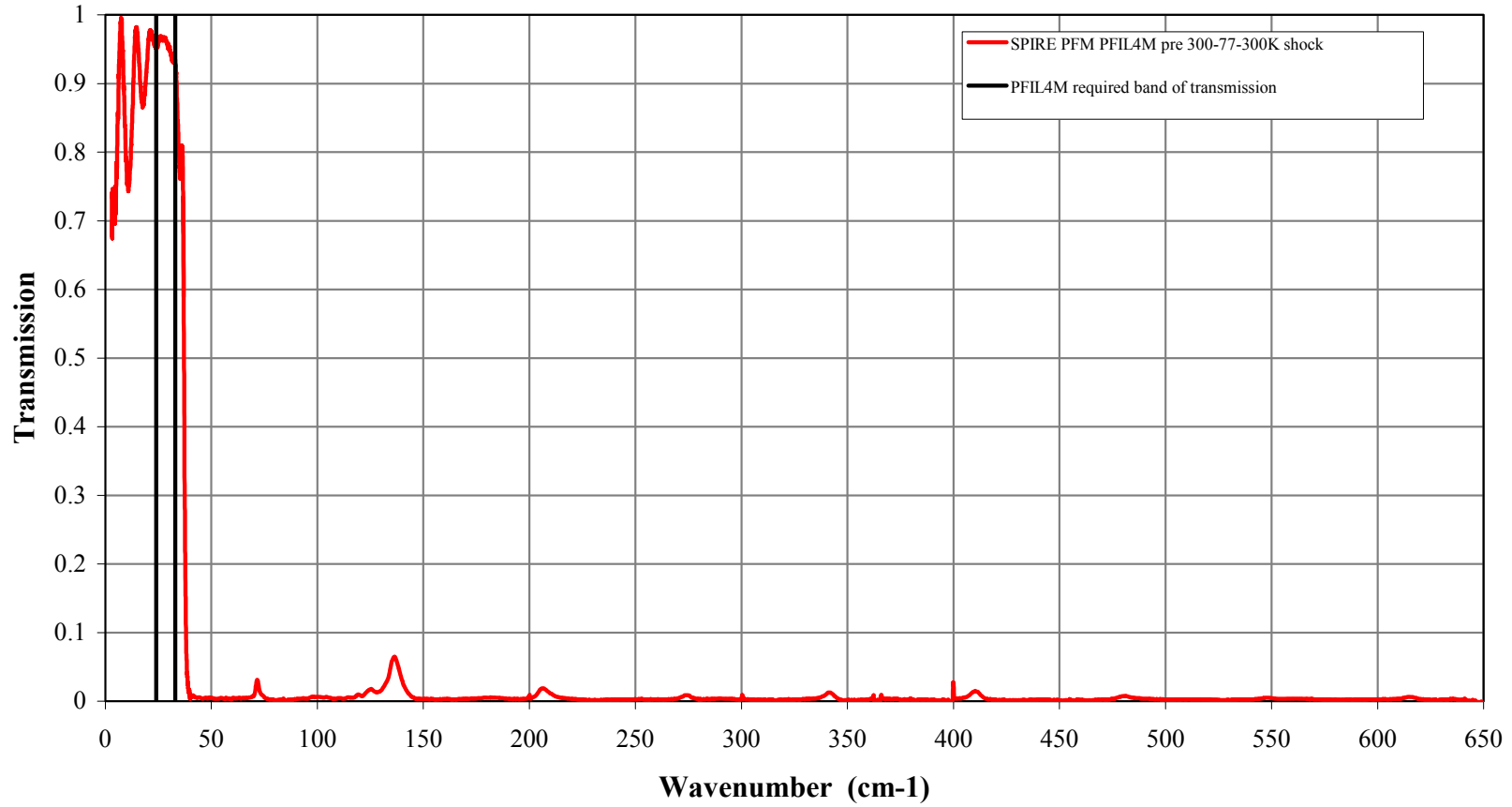

Figure 6 Spectroscopic data for PFM-PMW stack

Transmission spectrum of SPIRE PFM PFIL4M

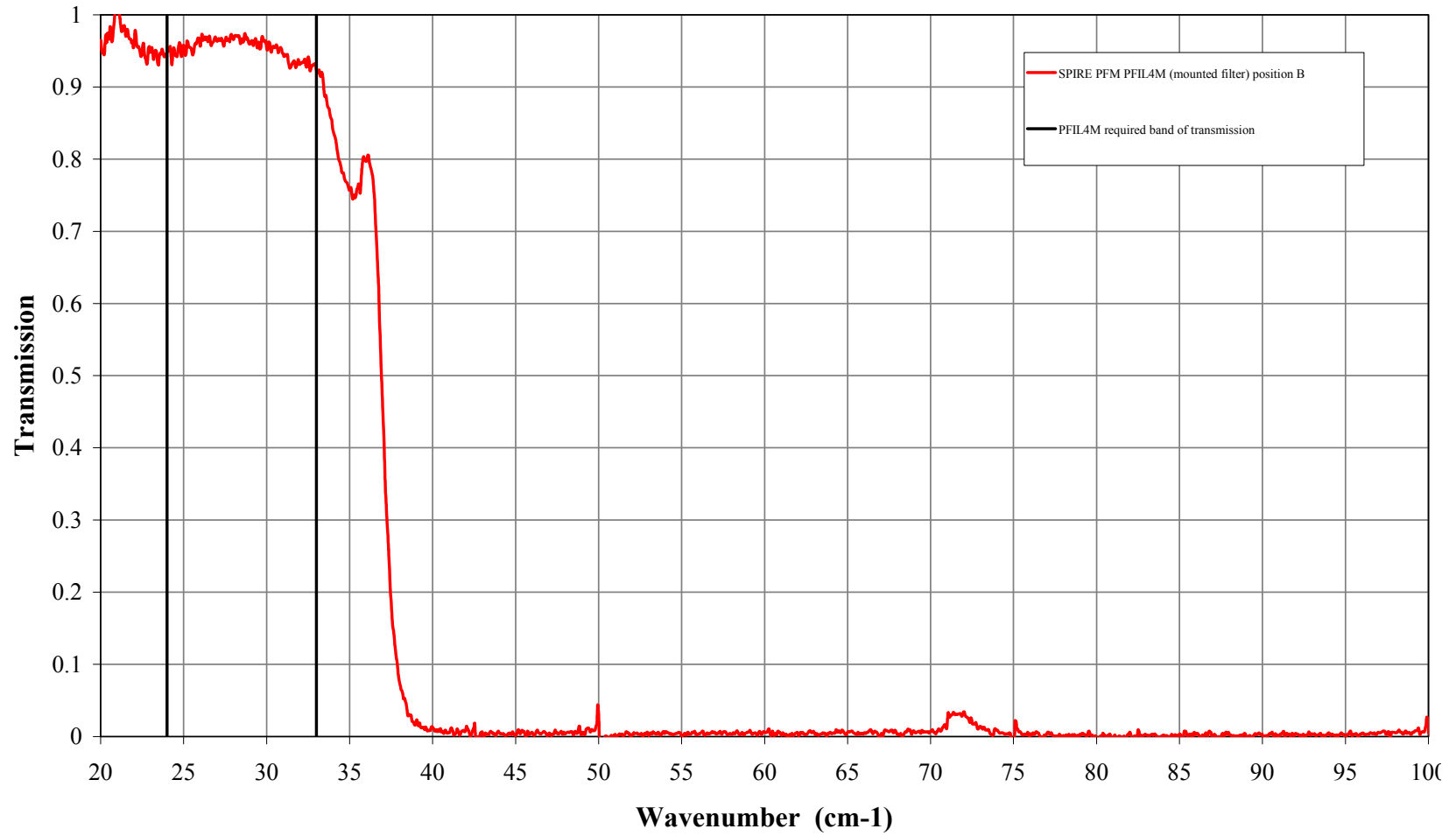

Figure 7 Spectroscopic data for PFM-PMW stack

Transmission spectrum of SPIRE PFM PFIL4M

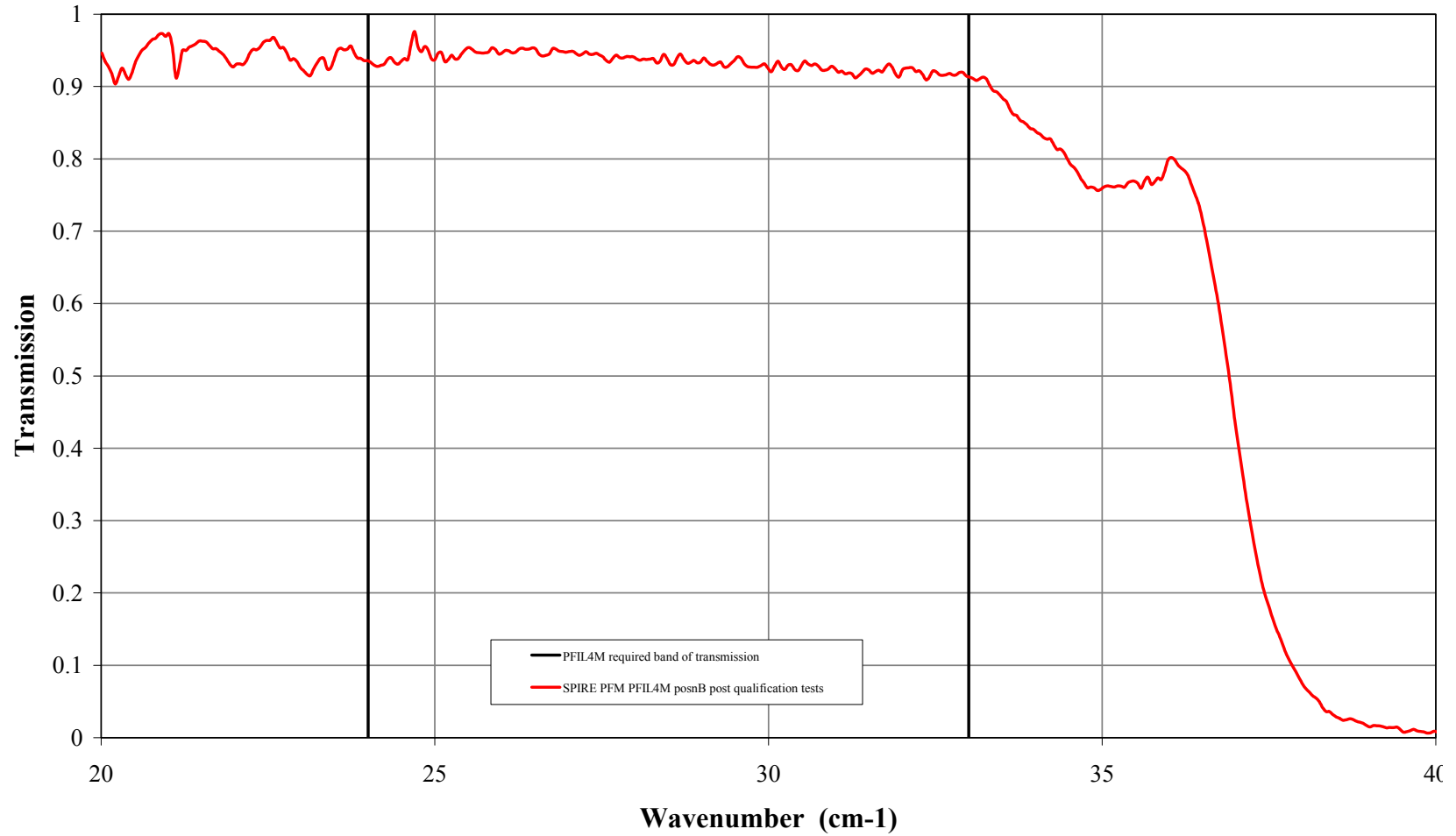

Figure 8 Spectroscopic data for PFM-PMW stack

SECTION 21 - Temporary Installation Record

SECTION 22 - Open Work / Deferred Work / Open Tests

Off-cuts of the filter material will be measured below 15µm using the Bomen spectrometer, once this facility is fully commissioned.

SECTION 23 - List of Non-Conformance Reports

SECTION 24 - Copies of Non-Conformance Reports

SECTION 25 - Test Reports

The filter module (PMW assembly) underwent the following series of qualification tests:-

- a) Post-manufacture spectroscopic measurements – 3-40cm⁻¹ and 10-140cm⁻¹
- b) Thermal shocks of the filter material. This consisted of five cycles of:-
 - Plunge filter material at room temperature into bath of liquid nitrogen and leave for 2 minutes
 - Remove filter material from LN₂ and place in oven at 320K for 10 minutes
- c) Visual inspection
- d) Cutting to size
- e) Visual inspection
- f) Spectroscopic measurements of filter material at three points over the filter area – 0-145cm⁻¹ range
- g) Cleaning and mounting in clamp
- h) Spectroscopic measurements in the range 20-650cm⁻¹
- i) PFM-PMW stack thermally cycled 300K-77K-300K
- j) Spectroscopic measurements - 10-145cm⁻¹ range
- k) PFM-PLW stack baked for 17Hrs at 350K
- l) Visual inspection under microscope
- m) Spectroscopic measurements of mounted assembly at three points over the filter area – 0-145cm⁻¹ range
 - Uniformity checks:-
 - The filter assembly was checked for uniformity at three points along the filters long axis - at the centre of the filter, and at two points along the long axis, 16mm either side of the central point.
 - The FTS geometric beam footprint was approximately 7mm diameter.

Spectroscopic tests – index

Spectroscopic tests were carried out according to standard UWC FTS procedures. Refer to historical record for index.

B734 uniformity check post mounting, pre thermal tests (300-77-300) (300-370-300)

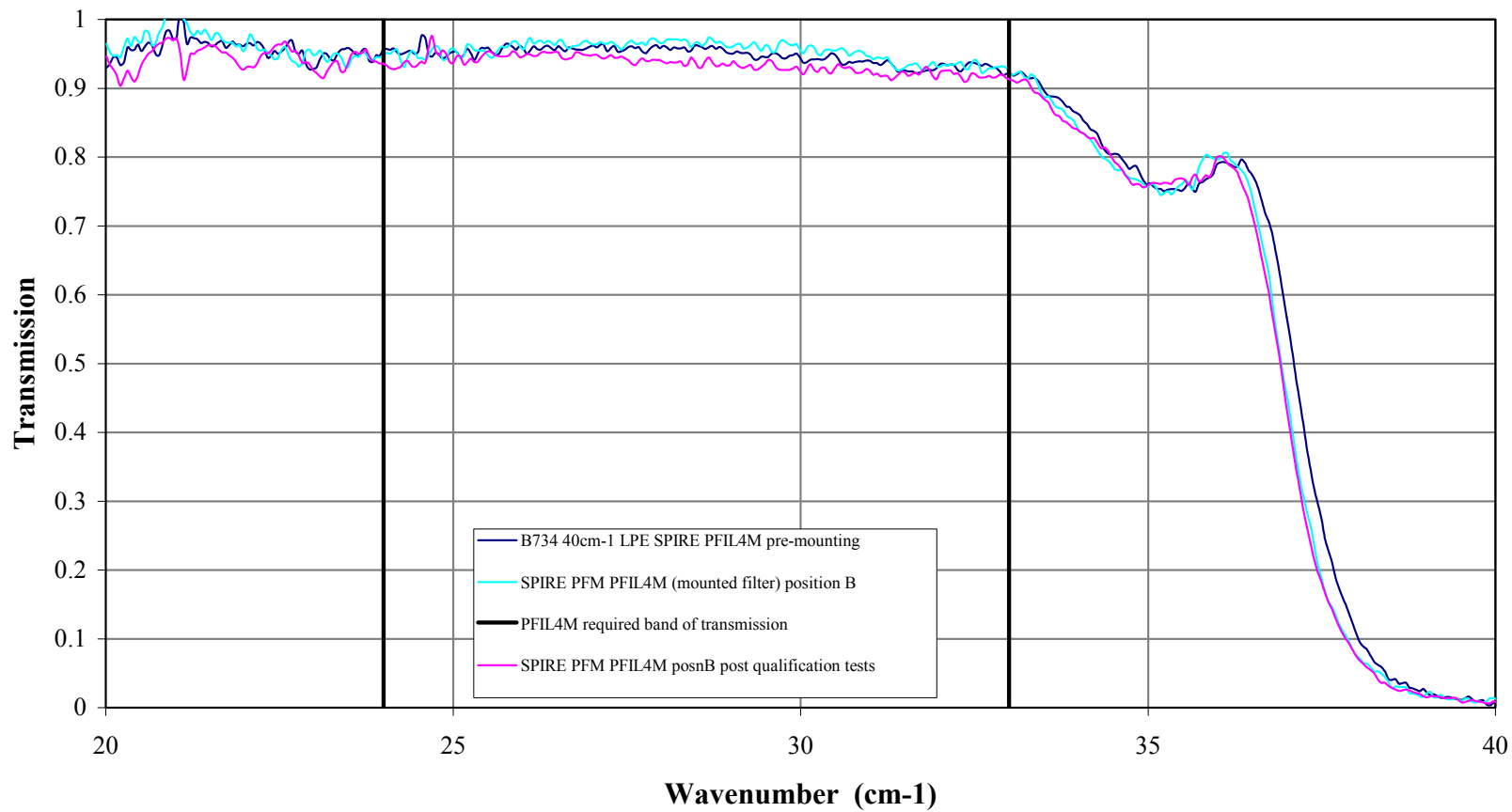

Figure 9 B734 filter uniformity post-mounting – 3-40cm⁻¹

Uniformity check post mounting, pre thermal tests (300-77-300) (300-370-300)

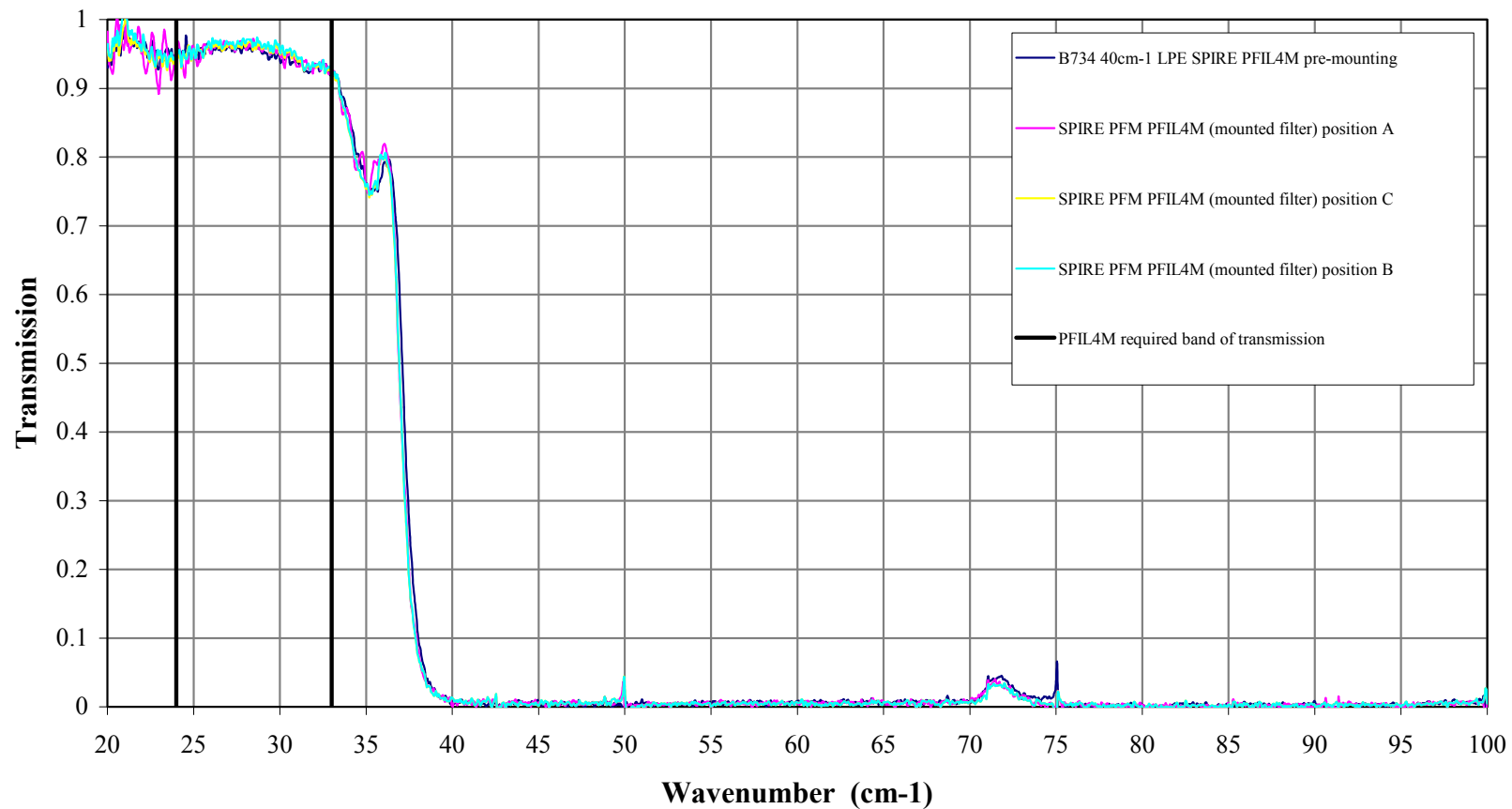

Figure 10 B734 filter uniformity post-mounting – 10-140cm⁻¹

B734 uniformity check post mounting, post thermal tests (300-77-300) (300-370-300)

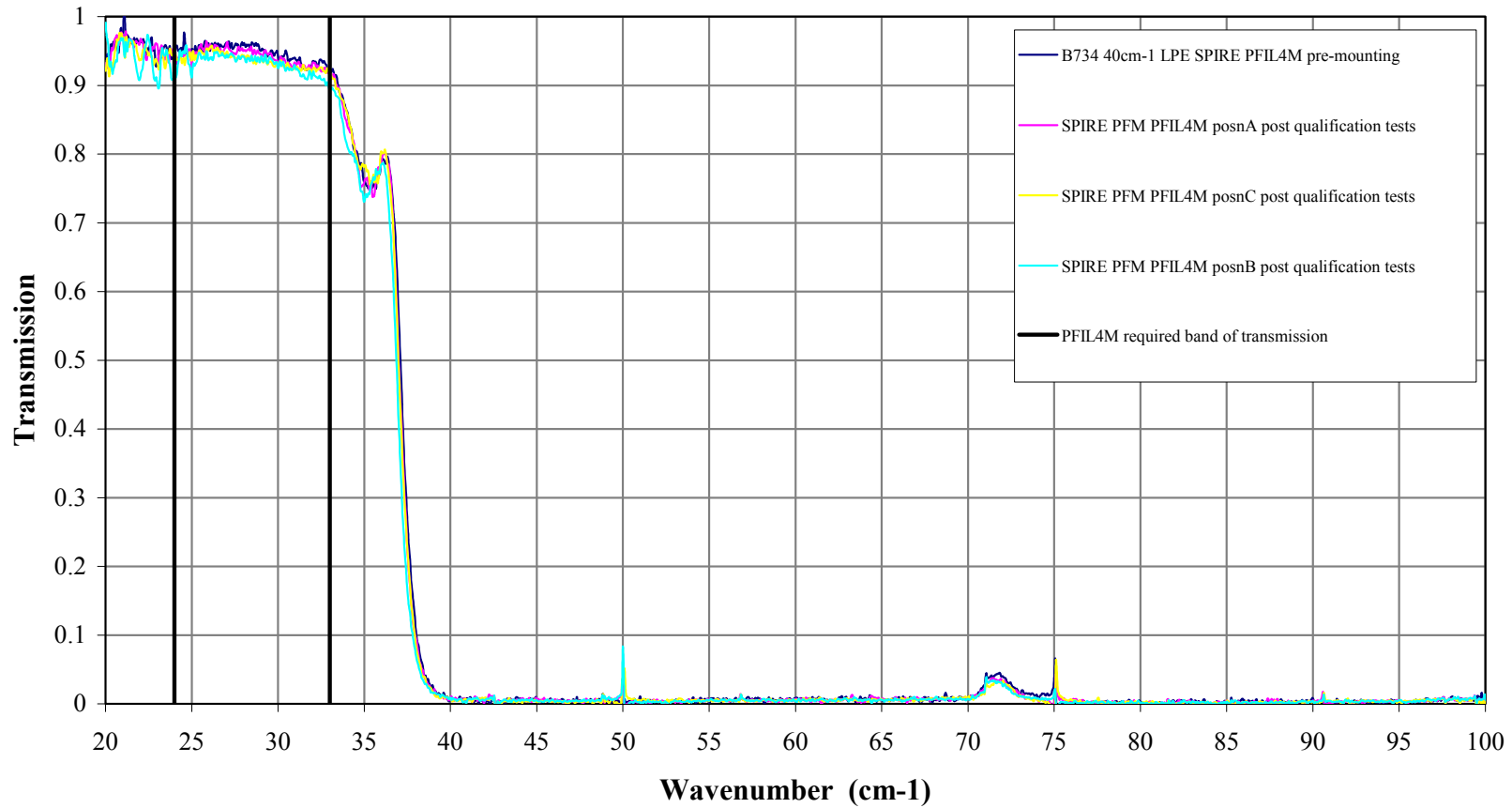

Figure 11 B734 filter uniformity post-mounting and thermal shocks/cycles – 10-140cm⁻¹

Transmission spectrum of SPIRE PFM PFIL4M from 3-650cm⁻¹

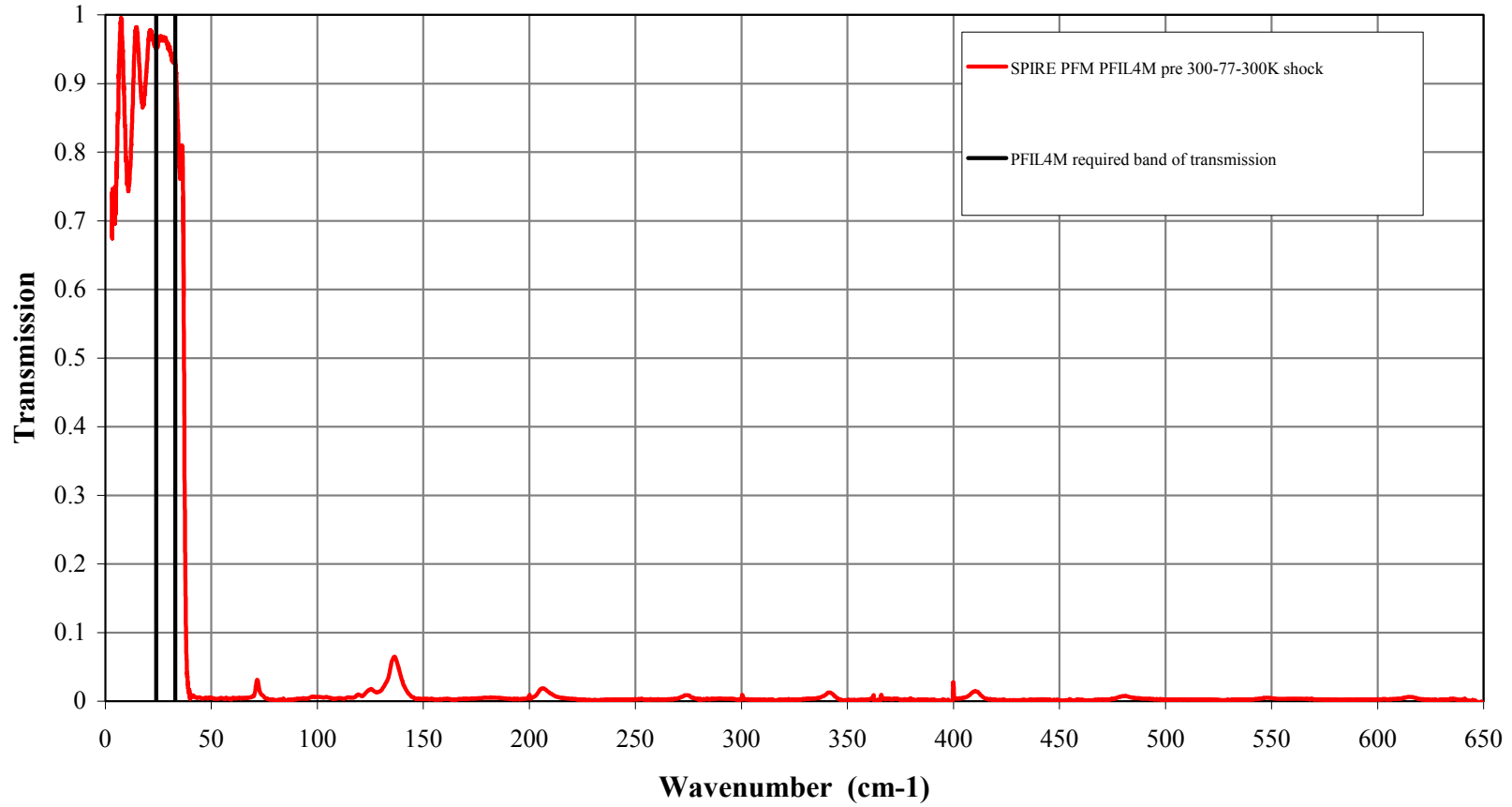

Figure 12 B734 filter assembly performance – 20-650cm⁻¹

SECTION 27 - Reference List of EIDP's

Associated

<u>Title</u> (Listed in alphabetical order)	<u>ID</u> (Serial No.)	<u>Acronym</u>	<u>Document No.</u>	<u>Issue</u>	<u>Date</u>
PLW BDA CQM EIDP					

Lower Level

<u>Title</u> (Listed in alphabetical order)	<u>ID</u> (Serial No.)	<u>Acronym</u>	<u>Document No.</u>	<u>Issue</u>	<u>Date</u>

SECTION 28 - Mass Records

Assembly	Final measured mass
FILT-PFM-240 – PFM PMW assembly	8.47 ± 0.01 g

SECTION 29 - Cleanliness Statement

SECTION 30 - Other Useful Information

SECTION 31 - DPL/DML etc

SECTION 32 – List of Appendices/Attachments

<u>Appendix #</u>	<u>Title</u> (Listed in alphabetical order)	<u>Document No.</u>	<u>Issue</u>	<u>Date</u>	<u>Notes</u>