

TECHNICAL NOTE

TITLE: HEATERS AND THERMISTORS DESCRIPTION AND LAYOUT

DRL Item or D.R.D. No: E-06

————— SIGNATURE AND APPROVALS ON ORIGINAL —————

PREPARED: M. CAIROLA

CHECKED: M. CAIROLA 

APPROVED: G. POIDOMANI

AUTHORIZED: E. SACCHI 

APPROVALS:

SYSTEM ENGINEER

X M. SIAS 

PRODUCT ASSURANCE:

R. VERGNANO 

CONFIGURATION CONTROL:

R. DROETTO 

PROGRAM MANAGER:

P. MUSI 

DATA MANAGEMENT:

  05/08/05

HERSCHEL PLANCK

DOC : H-P-TN-AI-0069
ISSUE : 05
DATE : 05/AUG/05
PAGE : 2 of 91
CLASS : DC

DOCUMENT CHANGE RECORD

ISSUE	DATE	REASON FOR CHANGE	AFFECTED PARAGRAPHS
01	30/01/2004	New Issue	All
02	14/07/2004	Updating	All
03	30/11/2004	Updating for implementation of CR632. Implementation of new heater line dedicated to Planck Helium tanks. Repositioning of heaters on the Propellant tanks (both S/C). Identification of the location of the Harness connectors to be used for RCS heater lines and relevant thermistors.	3, 4
04	16/02/2005	Updating of the thermistors position. Location of the RCS unit heaters. Definition of the bonding method for heaters and thermistors. Change of the heater tipology installed on the PLANCK Helium tank.	3, 4
05	05/08/2005	Change of the heater tipology installed on the HERSCHEL/PLANCK 20N Thruster	Paragraph 3 (Pages 6,12, 13,45,47,51,52, 83,84,85,86)
		Heaters repositioning on PLANCK 4K Panel	Paragraph 3 (Page 54)
		Additional Heater lines on HERSCHEL (line 36) and PLANCK (line 20) Propellant Tanks	Paragraph 3 (Pages 11,12, 21,42,43,50, 51,57,80,81,82)
		Remarks added on heaters connection constraints	Paragraph 3 (Pages 48,84)

HERSCHEL PLANCK

TABLE OF CONTENTS

1. INTRODUCTION.....	4
2. APPLICABLE AND REFERENCE DOCUMENT	5
2.1 APPLICABLE DOCUMENT	5
2.2 REFERENCE DOCUMENT	5
3. HEATERS	6
3.1 GENERALITY	6
3.1.1 <i>HERSCHEL TCS Heater lines description.....</i>	<i>11</i>
3.1.1.1 TCS Line circuit description.....	34
3.1.2 <i>PLANCK TCS Heater lines description.....</i>	<i>50</i>
3.1.2.1 TCS line circuit description.....	74
4. THERMISTORS.....	88
4.1 HERSCHEL THERMISTORS LIST.....	88
4.2 PLANCK THERMISTORS LIST.....	90

HERSCHEL PLANCK

1. INTRODUCTION

This document contains a description of heaters and thermistors used for the HERSCHEL and PLANCK S/C thermal control and gives all information useful for their installation as:

- Type
- Quantity
- Location
- Electrical connections
- Installation drawings
- Bonding method

2. APPLICABLE AND REFERENCE DOCUMENT

2.1 APPLICABLE DOCUMENT

- AD1 H-P-RP-AI-0040 SVM TCS THERMAL ANALYSIS REPORT
- AD2 H-P-TN-AI-0055 HEATER POWER UNCERTAINTY THERMAL ANALYSIS

2.2 REFERENCE DOCUMENT

- RD1 H-P-IC-AI-0001 Herschel/Planck SVM Mechanical Interface Control Document
- RD2 H-P-1-ASPI-SP-0027 General Design and Interface Requirements
- RD3 H-P-RP-AI-0039 TCS Design Description

3. HEATERS

3.1 GENERALITY

Foil heaters, used for HERSCHEL and PLANCK TCS, are listed in the table 3.1-1 and will be double circuits, double layer, thermofoil and internal redundant heater.

The thermistors shall be installed using adhesive AV138 as per ALENIA SPAZIO internal procedure (SG-PR-AI-121).

The thermistors on THRUSTER and PLANCK HELIUM TANK shall be installed using RTV566 as per ALENIA SPAZIO internal procedure (SG-PR-AI-121).

The flat heaters shall be installed with adhesive Y966 and drops of AV138 on the corners as per ALENIA SPAZIO internal procedure (SG-PR-AI-121).

The only exception is for the THRUSTER and PLANCK HELIUM TANK heaters that shall be installed using adhesive RTV566 as per ALENIA SPAZIO internal procedure (SG-PR-AI-121).

Table 3.1-1 Type of heaters

Type	Dimensions [mm]	Resistance [Ω]	Location	Wire Outlet type
B	100 x 26	155	Panels	X
C	137 x 55	47	Panels	X
D	320 x 21	945	Tanks	X
E	45 x 21	310	FCV 1N Thruster	Y
F	205 x 28	28.04	Heat Pipes	X
G	140 x 40	64	Panels	X
H1	See fig 3.1-1	74	Gyro	See fig 3.1-1
H2	See fig 3.1-1	150	Gyro	See fig 3.1-1
H3	See fig 3.1-2	240	Gyro	See fig 3.1-2
H4	See fig 3.1-2	150	Gyro	See fig 3.1-2
J	90 x 45	90	Panels and Star Trackers of PLANCK	X
K	50 x 20	42.5	RCS units	X
L	145 x 20	276	Star trackers HERSCHEL	X
M	70 x 15	700	PLANCK Helium tanks	X
N	47 x 14	510	FCV 20N Thruster	Y
Wire	AWG 26	11.31 Ω /m	RCS piping	-

Wire outlet type X



Wire outlet type Y



HERSCHEL PLANCK

In the tables 3.1.1-1 and 3.1.2-1 the heater lines are described. For each line, the columns contain:

1. Line number
2. Location on the S/C
3. Line name: the character N means enabled in Nominal and S enabled in Survival
4. Units controlled
5. Total number of heaters
6. Heater type used on the line
7. Heater name: each heater is identified by a heater name AB-XX-Y (M or R) where:
 - A identify the S/C (H for HERSCHEL and P for PLANCK)
 - B identify the line (first column of table 3.1.1-1 and 3.1.2-1)
 - XX identify the progressive number in the same line.
 - Y identify the heater type (first column of table 3.1-1)
 - M or R identify the Main or Redundant circuit
8. Resistance value of the heater
9. Configuration of the heaters if in parallel or series (electrical scheme in para 3.1.1.1 and 3.1.2.1)
10. Equivalent resistance of the line
11. Thermistors numbering commanding the line
12. Power dissipation of the line evaluated at 27 V.
13. Reference figure

In the figures from 3.1.1-1 to 3.1.1-12 the Herschel heaters and thermistors (THM) location is shown.

In the figures from 3.1.2-1 to 3.1.2-13 the Planck heaters and thermistors (THM) location is shown.

For the complete THM location description see para 4.

SPECIAL REMARKS

All the flat heaters have a MAIN circuit and a REDUNDANT circuit. The same electrical connection shall be done both for the MAIN circuit and for the REDUNDANT circuit as shown in the sketch below as example

HERSCHEL PLANCK

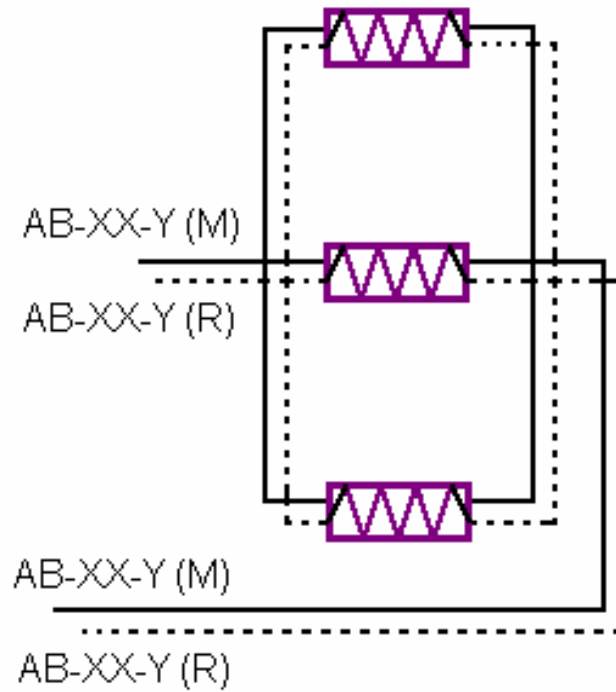

This configuration has to be intended applicable for *ALL* the heater circuit shown in this document even if in the sketches given in paragraph 3.1.1.1 and paragraph 3.1.2.1 the dotted line (identifying the REDUNDANT circuit) is omitted.

HERSCHEL PLANCK

Figure 3.1-1 HERSCHEL GYRO heaters type H1 & H2

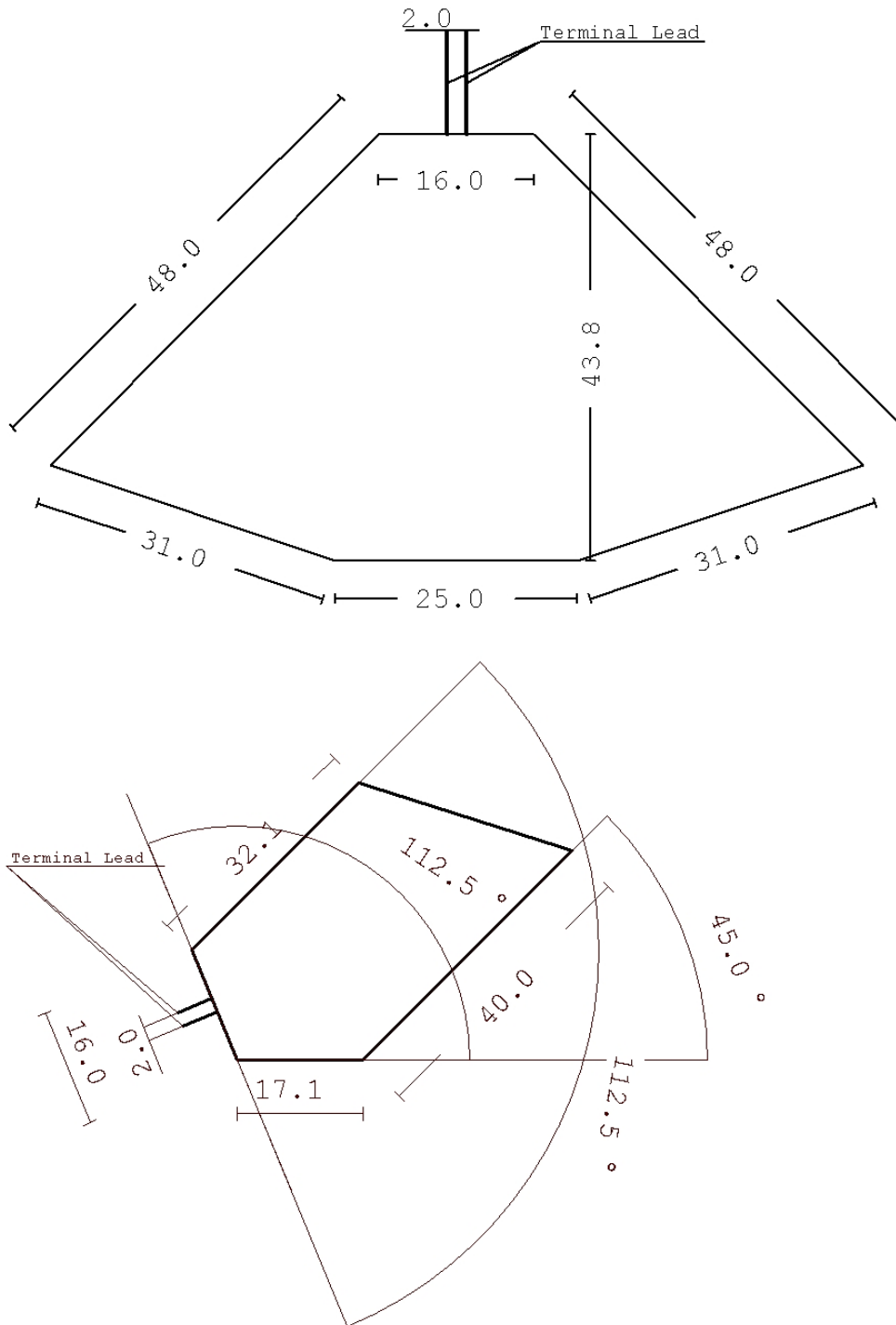

HERSCHEL PLANCK

Figure 3.1-2 HERSCHEL GYRO heaters type H3 & H4

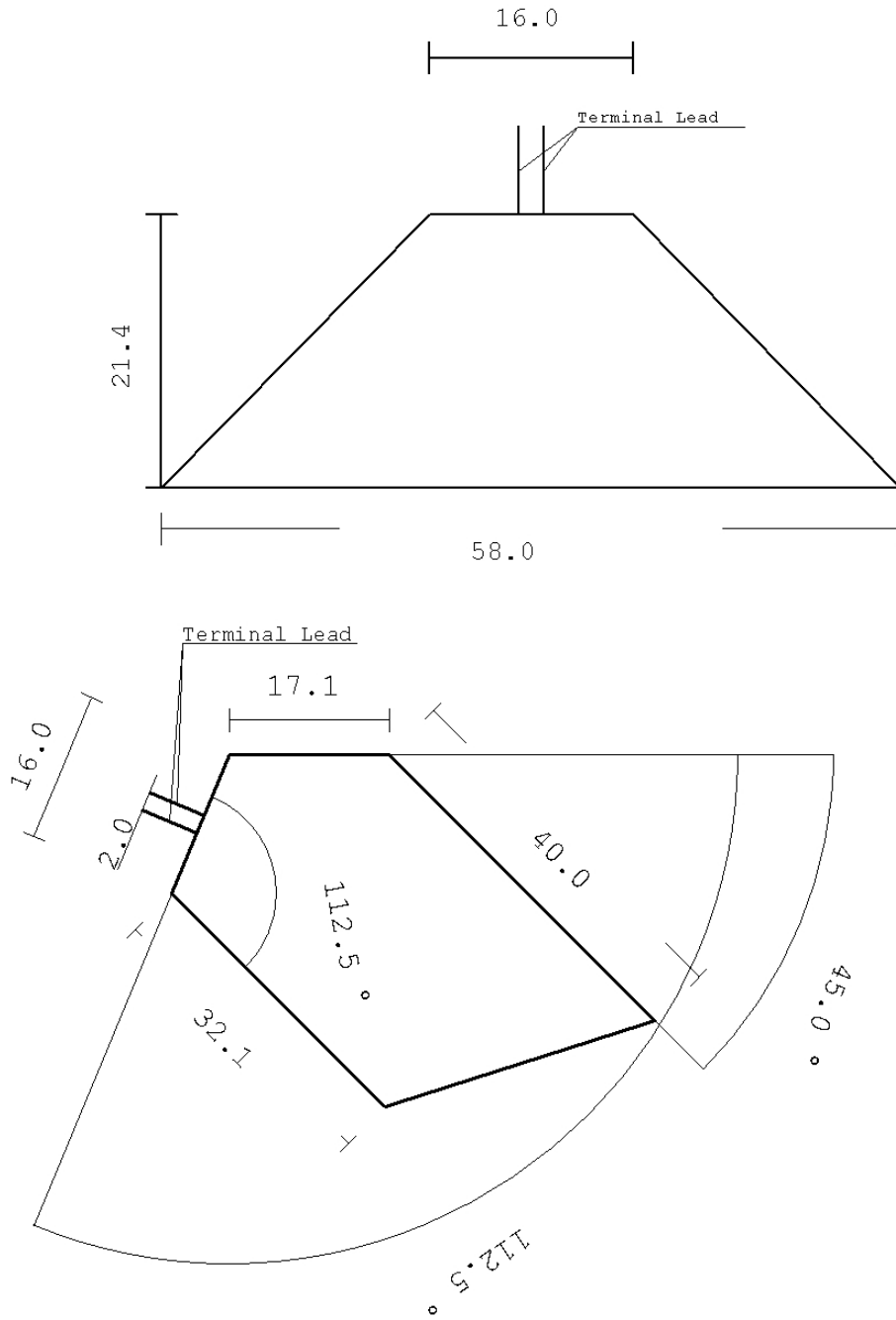

HERSCHEL PLANCK

3.1.1 HERSCHEL TCS Heater lines description

Table 3.1.1-1

Line N.	Location	Line Name	Reference Unit	Total Heater	Heater Type	Heater Id.	Resistance [ohm]	Electrical Connection Type	Equivalent Resistance [ohm]	Heater Line commanded by THM	Equivalent Power @27 V [W]	Reference Figure
1	+Y+Z	HTR104NS	XPND1	1	G	H1-01-G (M+R)	64	-	64	49/97/145	11.39	3.1.1-1
2		HTR105NS	XPND2	1	G	H2-01-G (M+R)	64	-	64	50/98/146	11.39	
3	+Y	HTR204NS	BATTERY (*)	(*)	(*)	(*)	(*)	(*)	(*)	51/99/147	14.9 (*)	3.1.1-3
4		Spare	-	-	-	-	-	-	-	-	-	
5	+Y-Z	HTR301S	FPSPU / FPDPU	2	C	H5-01-C (M+R)	47	PARALLEL	23.50	53/101/149	31.02	3.1.1-2
					C	H5-02-C (M+R)	47					
6		HTR304NS	FPBOLC	2	B	H6-01-B (M+R)	155	PARALLEL	77.50	54/102/150	9.41	
					B	H6-02-B (M+R)	155					
7		Spare	-	-	-	-	-	-	-	-	-	
8	HTR305S	FPDECMC	3	G	H8-01-G (M+R)	64	PARALLEL	26.52	56/104/152	27.48		
				G	H8-02-G (M+R)	64						
				B	H8-03-B (M+R)	155						
9	RCS	HTR1523NS	PIPES		WIRE			SERIES	See H-P-TN-AI-0104	57/105/153	See H-P-TN-AI-0104	See H-P-TN-AI-0104
10	-Z	HTR401S	CCU/HSDCU/ HSFCU	5	C	H10-01-C (M+R)	47	PARALLEL	16.38	58/106/154	44.51	3.1.1-4
					J	H10-02-J (M+R)	90					
					J	H10-03-J (M+R)	90					
					J	H10-04-J (M+R)	90					
					B	H10-05-B (M+R)	155					
11	RCS	HTR1562NS	PIPES		WIRE			SERIES	See H-P-TN-AI-0104	59/107/155	See H-P-TN-AI-0104	See H-P-TN-AI-0104
12	-Y-Z	HTR501NS	FHWOV	2	G	H12-01-G (M+R)	64	PARALLEL	32	60/108/156	22.78	3.1.1-5
					G	H12-02-G (M+R)	64					
13		HTR502S	FHHRV	4	J	H13-01-J (M+R)	90	PARALLEL	18.70	61/109/157	38.98	
					J	H13-02-J (M+R)	90					
					G	H13-03-G (M+R)	64					
	G	H13-04-G (M+R)	64									
14	HTR504S	FHFCU	3	B	H14-01-B (M+R)	155	PARALLEL	35.05	62/110/158	20.79		
				G	H14-02-G (M+R)	64						
				B	H14-03-B (M+R)	155						
15	HTR506S	FHWEV/FHICU	4	G	H15-01-G (M+R)	64	PARALLEL	20.43	63/111/159	35.7		
				J	H15-02-J (M+R)	90						
				J	H15-03-J (M+R)	90						
				J	H15-04-J (M+R)	90						

HERSCHEL PLANCK

Line N.	Location	Line Name	Reference Unit	Total Heater	Heater Type	Heater Id.	Resistance [ohm]	Electrical Connection Type	Equivalent Resistance [ohm]	Heater Line commanded by THM	Equivalent Power @27 V [W]	Reference Figure
16	-Y	HTR601NS	FHWOH	4	J	H16-01-J (M+R)	90	PARALLEL	22.5	64/112/160	32.40	3.1.1-6
					J	H16-02-J (M+R)	90					
					J	H16-03-J (M+R)	90					
					J	H16-04-J (M+R)	90					
17		HTR602S	FHWEH	4	J	H17-01-J (M+R)	90	PARALLEL	22.5	65/113/161	32.40	
					J	H17-02-J (M+R)	90					
					J	H17-03-J (M+R)	90					
					J	H17-04-J (M+R)	90					
18		HTR603S	FHHRH	4	J	H18-01-J (M+R)	90	PARALLEL	18.7	66/114/162	38.98	
					J	H18-02-J (M+R)	90					
					G	H18-03-G (M+R)	64					
					G	H18-04-G (M+R)	64					
19	HTR604S	FHLCU/FHIFH	3	J	H19-01-J (M+R)	90	PARALLEL	34.88	67/115/163	20.90		
				J	H19-02-J (M+R)	90						
				B	H19-03-B (M+R)	155						
20	HTR605S	FHLSU	4	J	H20-01-J (M+R)	90	PARALLEL	25.14	68/116/164	29.00		
				J	H20-02-J (M+R)	90						
				B	H20-03-B (M+R)	155						
				J	H20-04-J (M+R)	90						
21	-Y+Z	HTR702NS	RWL2	1	G	H21-01-G (M+R)	64	-	64	69/117/165	11.39	3.1.1-7
22		HTR704NS	RWL4	1	G	H22-01-G (M+R)	64	-	64	70/118/166	11.39	
23		HTR701NS	RWL1	1	G	H23-01-G (M+R)	64	-	64	71/119/167	11.39	
24		HTR703NS	RWL3	1	G	H24-01-G (M+R)	64	-	64	72/120/168	11.39	
25	TANKS	HTR70NS	TANK+Y	7	D	H25-01-D (M+R)	945	PARALLEL (**)	135	73/121/169	5.4	3.1.1-8
					D	H25-02-D (M+R)	945					
					D	H25-03-D (M+R)	945					
					D	H25-04-D (M+R)	945					
					D	H25-05-D (M+R)	945					
					D	H25-06-D (M+R)	945					
					D	H25-07-D (M+R)	945					

(**) **REMARKS:** These Heater connections must be performed outside of the TANK MLI blankets

HERSCHEL PLANCK

Line N.	Location	Line Name	Reference Unit	Total Heater	Heater Type	Heater Id.	Resistance [ohm]	Electrical Connection Type	Equivalent Resistance [ohm]	Heater Line commanded by THM	Equivalent Power @27 V [W]	Reference Figure
26	TANKS	HTR71NS	TANK-Y	7	D	H26-01-D (M+R)	945	PARALLEL (**)	135	74/122/170	5.4	3.1.1-8
					D	H26-02-D (M+R)	945					
					D	H26-03-D (M+R)	945					
					D	H26-04-D (M+R)	945					
					D	H26-05-D (M+R)	945					
					D	H26-06-D (M+R)	945					
					D	H26-07-D (M+R)	945					
27	STAR TRAC.	HTR2000NS	STAR TRACKER	8	L	H27-01-L (M+R)	276	PARALLEL	34.50	75/123/171	21.13	3.1.1-9
					L	H27-02-L (M+R)	276					
					L	H27-03-L (M+R)	276					
					L	H27-04-L (M+R)	276					
					L	H27-05-L (M+R)	276					
					L	H27-06-L (M+R)	276					
					L	H27-07-L (M+R)	276					
28	-Y-Z	HTR507NS	FHIFV	1	G	H28-01-G (M+R)	64	-	64	76/124/172	11.4	3.1.1-5
29	20 N TH	HTR8133NS	FCV A1A	1	N	H29-01-E (M+R)	510	-	510	77/125/173	1.43	3.1.1-10
30		HTR8233NS	FCV C2A	1	N	H30-01-E (M+R)	510	-	510	78/126/174	1.43	
31		HTR8333NS	FCV C1A	1	N	H31-01-E (M+R)	510	-	510	79/127/175	1.43	
32		HTR8433NS	FCV A2A	1	N	H32-01-E (M+R)	510	-	510	80/128/176	1.43	
33		HTR8533NS	FCV C4A	1	N	H33-01-E (M+R)	510	-	510	81/129/177	1.43	
34		HTR8633NS	FCV C3A	1	N	H34-01-E (M+R)	510	-	510	82/130/178	1.43	
35	RCS	HTR1544NS	PIPES		WIRE			SERIES	See H-P-TN-AI-0104	83/131/179	See H-P-TN-AI-0104	See H-P-TN-AI-0104
36	TANKS	HTR7071NS	TANK+Y/ -Y	2	D	H36-01-D (M+R)	945	PARALLEL (**)	472.5	-	1.54	3.1.1-8
					D	H36-02-D (M+R)	945					
37	RCS	HTR1554NS	PIPES		WIRE			SERIES	See H-P-TN-AI-0104	85/133/181	See H-P-TN-AI-0104	See H-P-TN-AI-0104

(**) **REMARKS:** These Heater connections must be performed outside of the TANK MLI blankets

HERSCHEL PLANCK

Line N.	Location	Line Name	Reference Unit	Total Heater	Heater Type	Heater Id.	Resistance [ohm]	Electrical Connection Type	Equivalent Resistance [ohm]	Heater Line commanded by THM	Equivalent Power @27 V [W]	Reference Figure
38	Gyro	HTR100NS	GYRO	8	H1	H38-01-H1 (M+R)	74	PARALLEL	16.12	86/134/182	45.22	3.1.1-12
					H1	H38-02-H1 (M+R)	74					
					H2	H38-03-H2 (M+R)	150					
					H2	H38-04-H2 (M+R)	150					
					H3	H38-05-H3 (M+R)	240					
					H3	H38-06-H3 (M+R)	240					
					H4	H38-07-H4 (M+R)	150					
					H4	H38-08-H4 (M+R)	150					
39	20 N TH	HTR8134NS	FCV A1B	1	N	H39-01-E (M+R)	510	-	510	87/135/183	1.43	3.1.1-10
40		HTR8234NS	FCV C2B	1	N	H40-01-E (M+R)	510	-	510	88/136/184	1.43	
41		HTR8334NS	FCV C1B	1	N	H41-01-E (M+R)	510	-	510	89/137/185	1.43	
42		HTR8434NS	FCV A2B	1	N	H42-01-E (M+R)	510	-	510	90/138/186	1.43	
43		HTR8534NS	FCV C4B	1	N	H43-01-E (M+R)	510	-	510	91/139/187	1.43	
44		HTR8634NS	FCV C3B	1	N	H44-01-E (M+R)	510	-	510	92/140/188	1.43	
45	RCS	HTR1513NS	PIPES		WIRE			SERIES	See H-P-TN-AI-0104	93/141/189	See H-P-TN-AI-0104	See H-P-TN-AI-0104
46	RCS	HTR1506NS	PIPES		WIRE			SERIES	See H-P-TN-AI-0104	94/142/190	See H-P-TN-AI-0104	See H-P-TN-AI-0104
47	RCS	HTR1535NS	PIPES		WIRE			SERIES	See H-P-TN-AI-0104	95/143/191	See H-P-TN-AI-0104	See H-P-TN-AI-0104
48	RCS	HTR1550NS	PT	1	K	H36-01-K (M+R)	42.5	SERIES/ PARALLEL	148.8	96/144/192	4.9	3.1.1-10b
			LV1	1	K	H36-02-K (M+R)	42.5					
			LV2	1	K	H36-03-K (M+R)	42.5					
			LF	2	K	H36-04-K (M+R)	42.5					
					K	H36-05-K (M+R)	42.5					

HERSCHEL PLANCK

Figure 3.1.1-1 HERSCHEL+Y+Z Panel (TT & C)

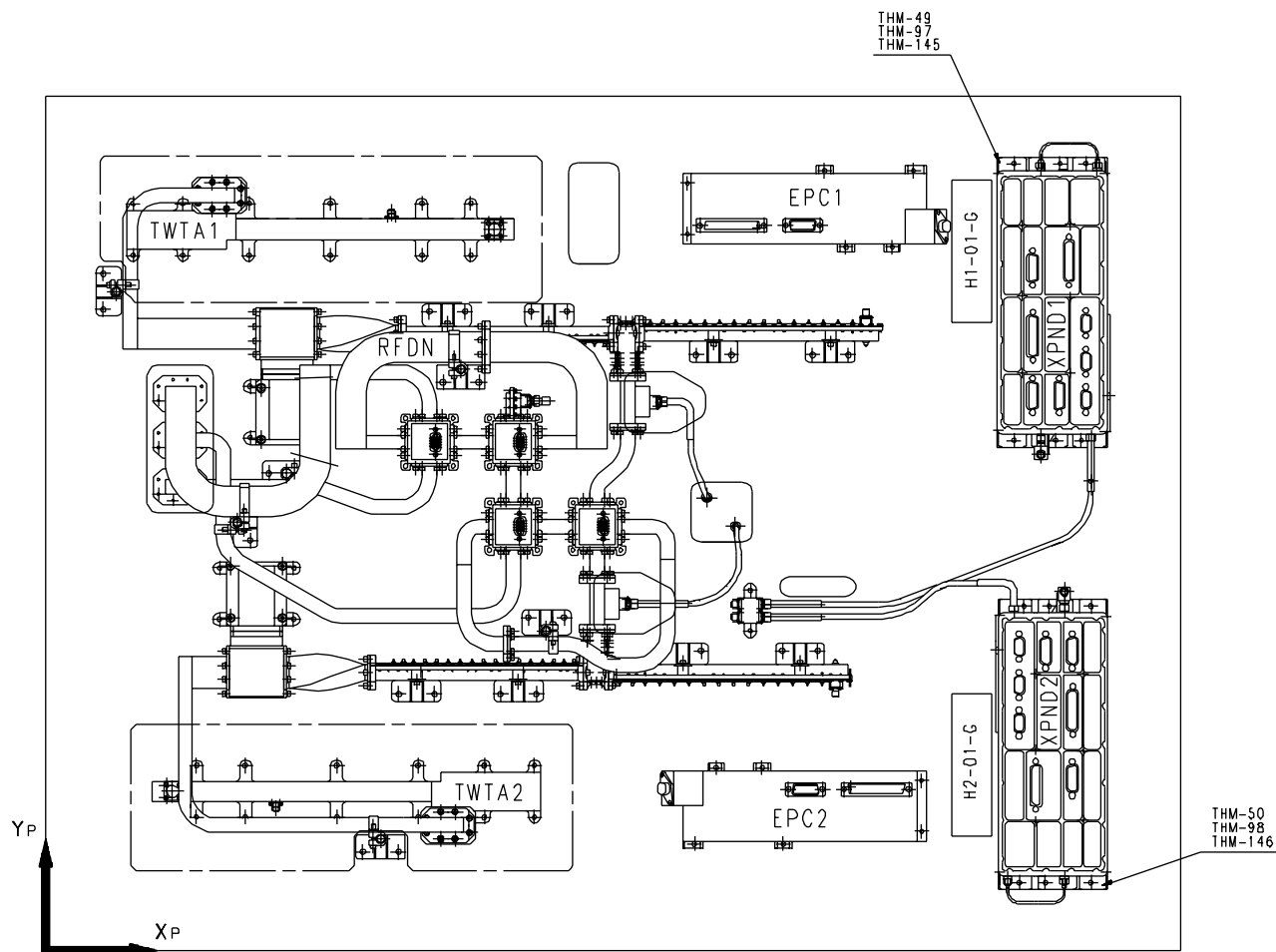

HERSCHEL PLANCK

Figure 3.1.1-2 HERSCHEL +Y-Z Panel (PACS)

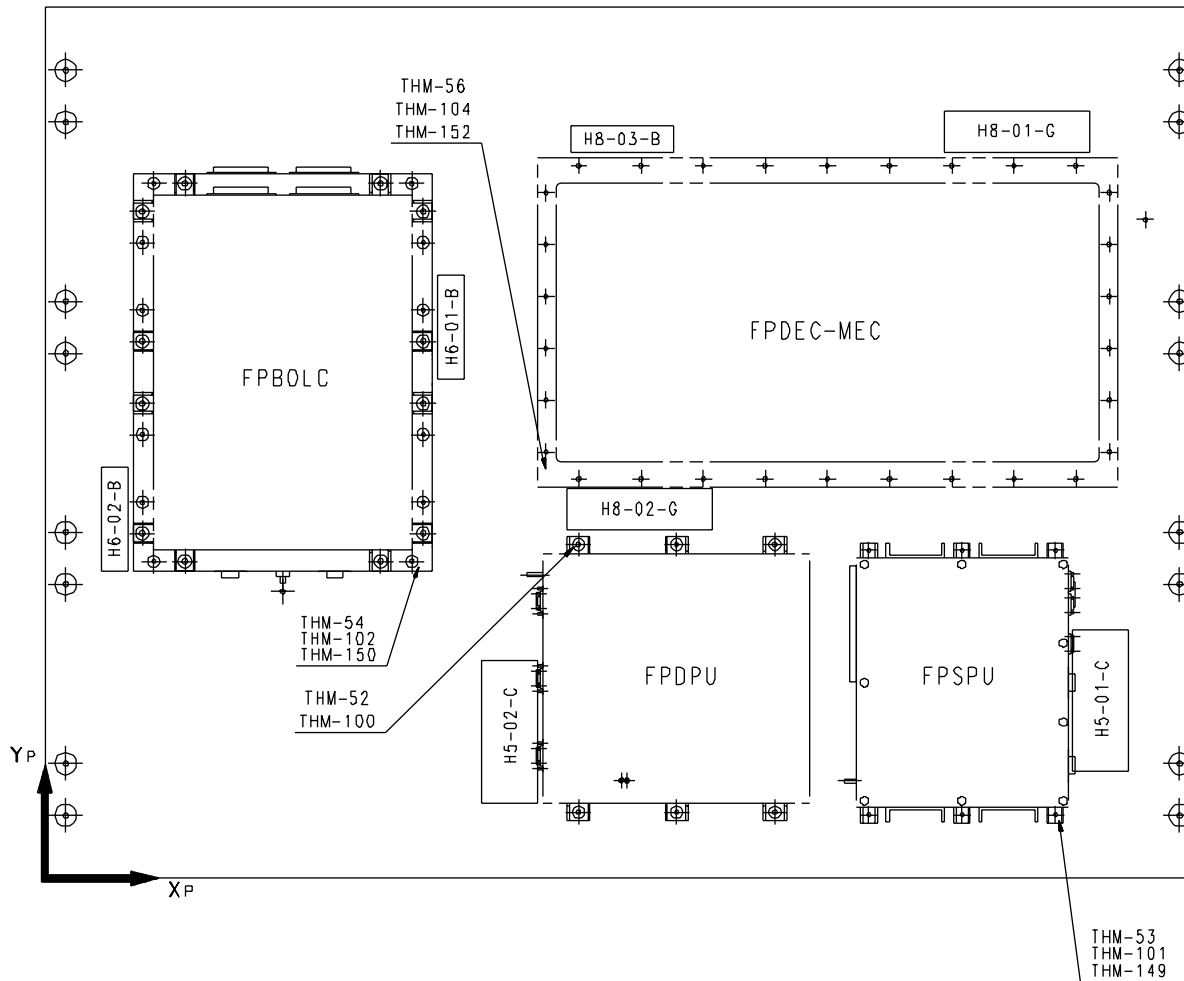

HERSCHEL PLANCK

Figure 3.1.1-3 HERSCHEL +Y Panel (PWR)

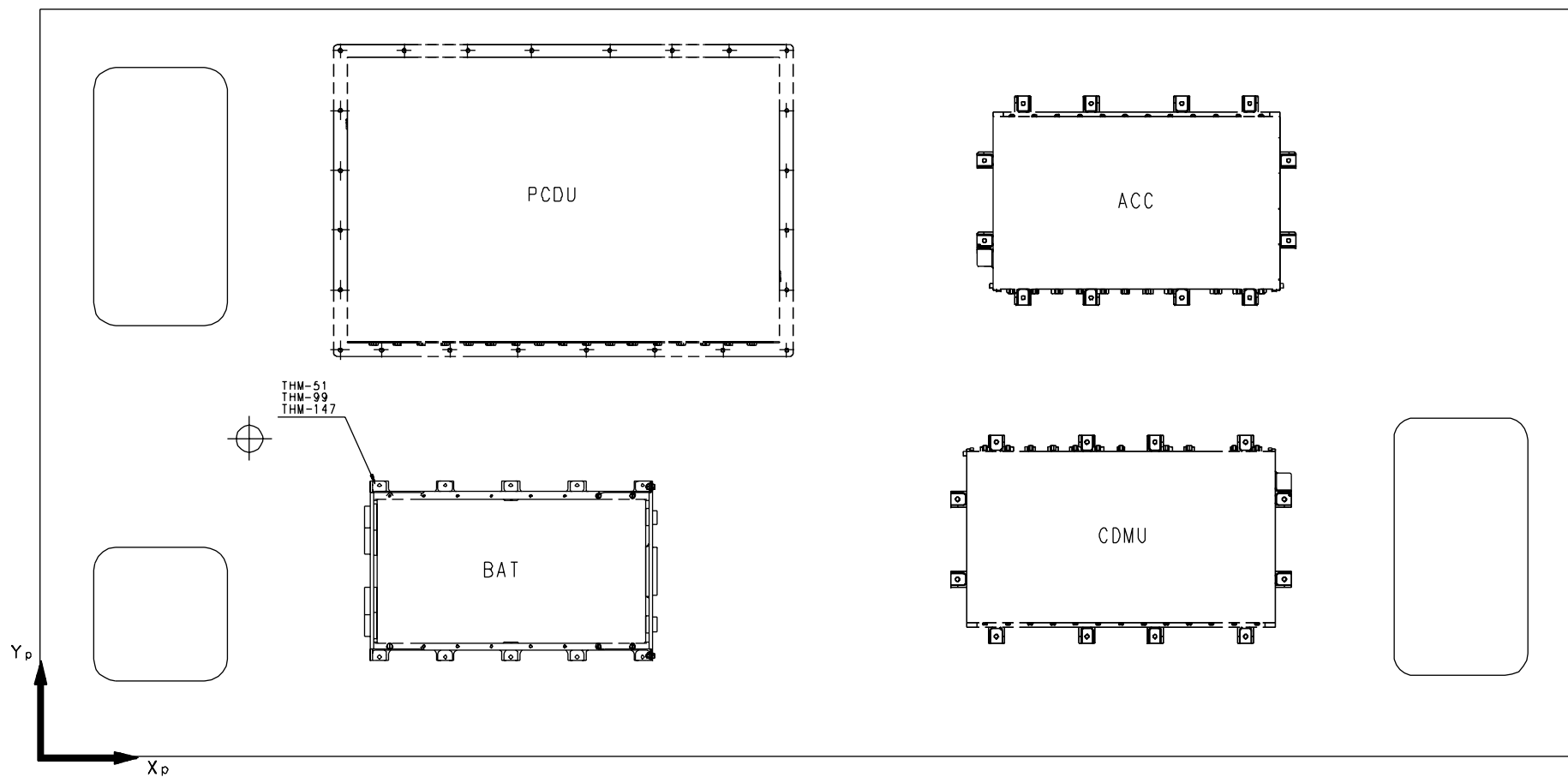

HERSCHEL PLANCK

Figure 3.1.1-4 HERSCHEL –Z Panel (SPIRE)

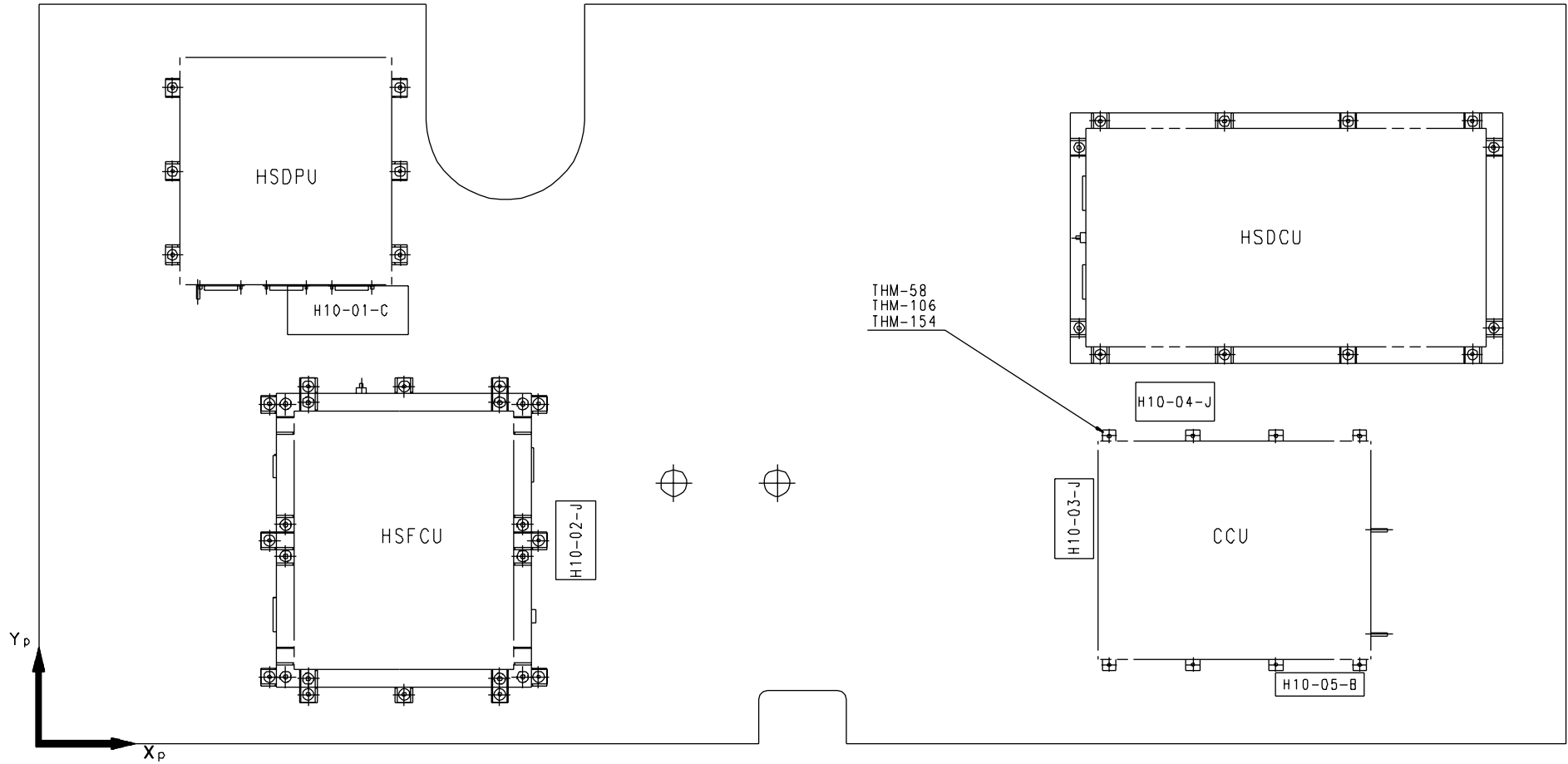

HERSCHEL PLANCK

Figure 3.1.1-5 HERSCHEL -Y-Z Panel (HIFI 2)

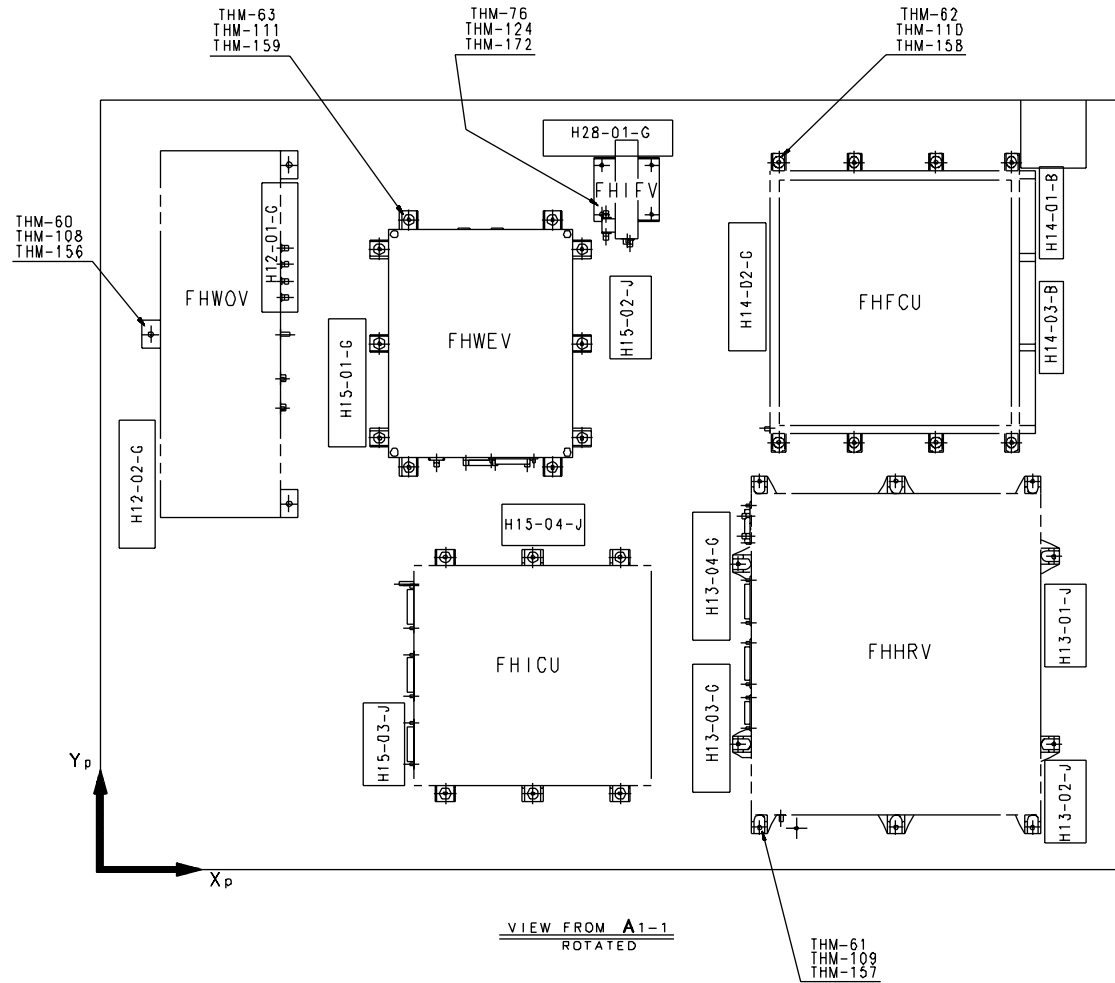

HERSCHEL PLANCK

Figure 3.1.1-6 HERSCHEL -Y Panel (HIFI 1)

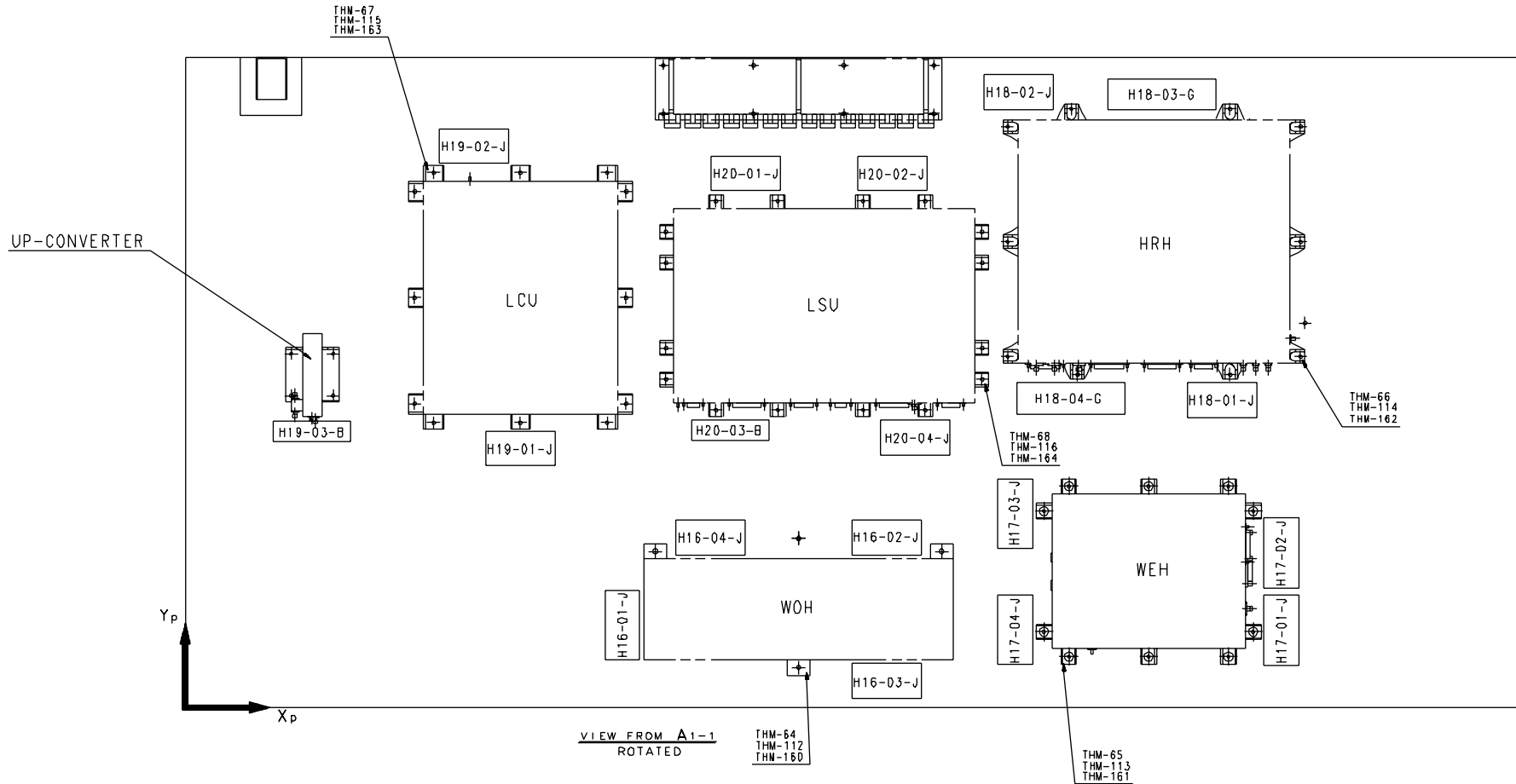

HERSCHEL PLANCK

Figure 3.1.1-7 HERSCHEL -Y+Z Panel (RWL)

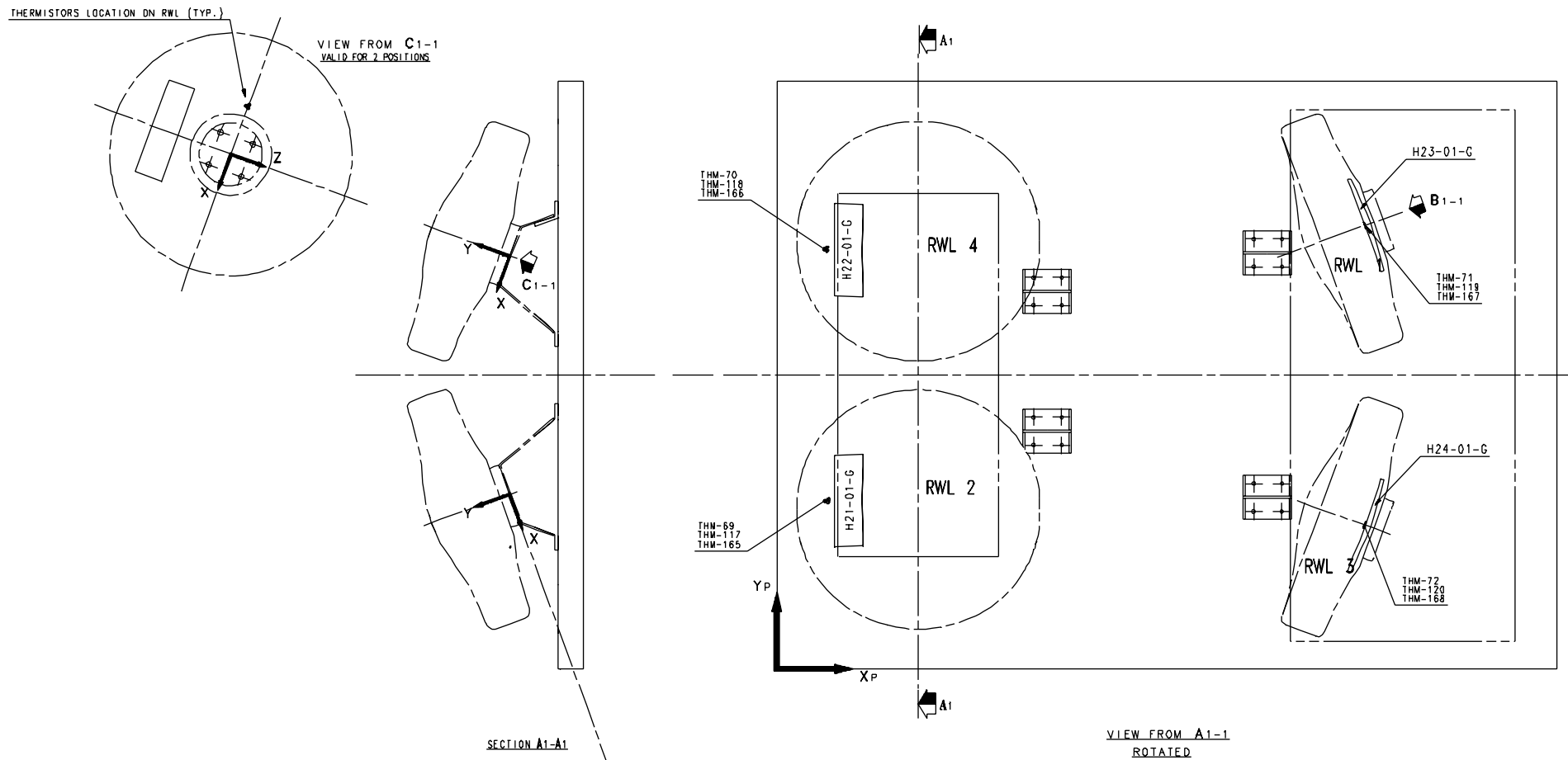

HERSCHEL PLANCK

Figure 3.1.1-8 HERSCHEL Tanks

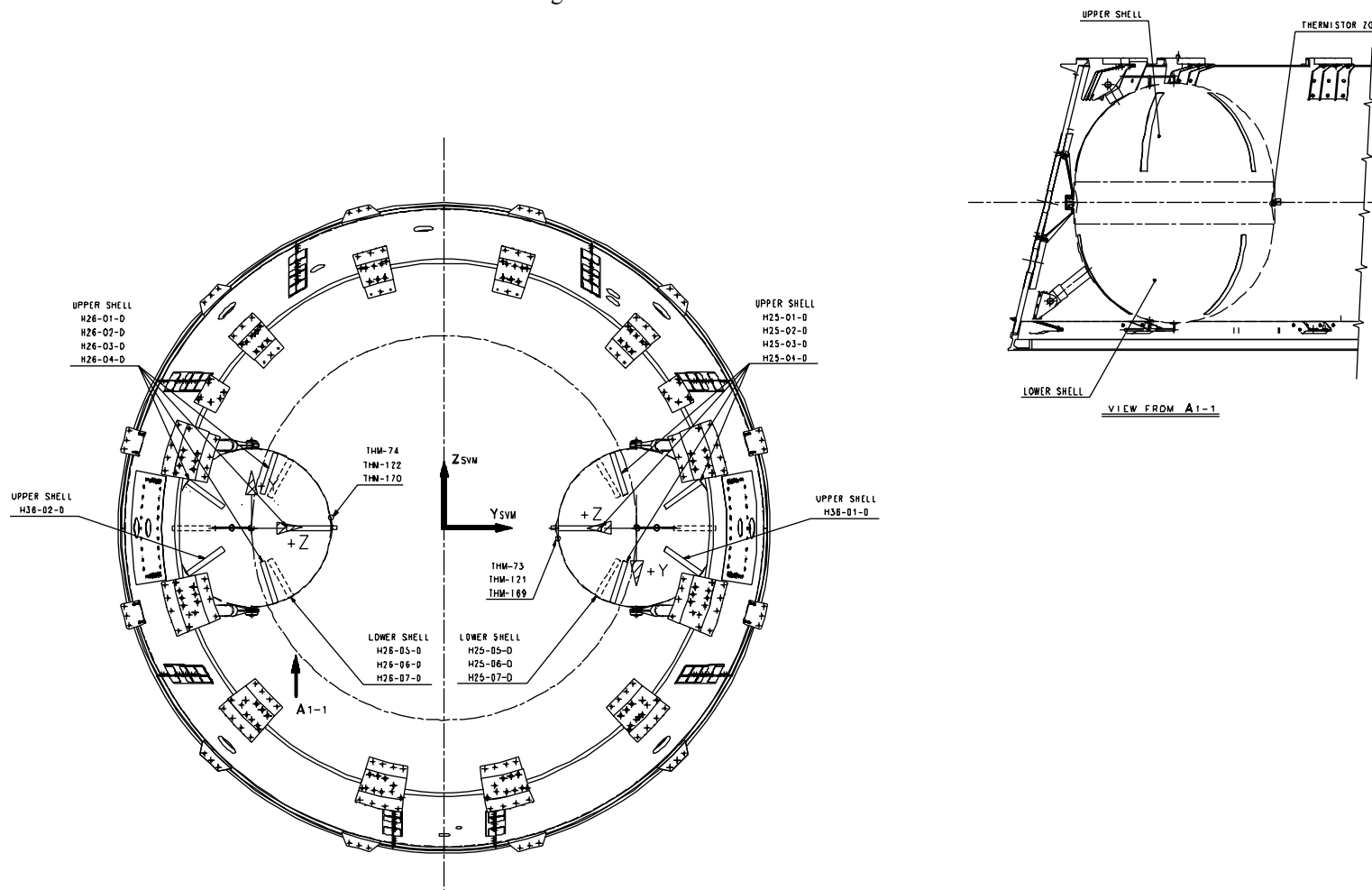

HERSCHEL PLANCK

Figure 3.1.1-9 HERSCHEL Star Trackers

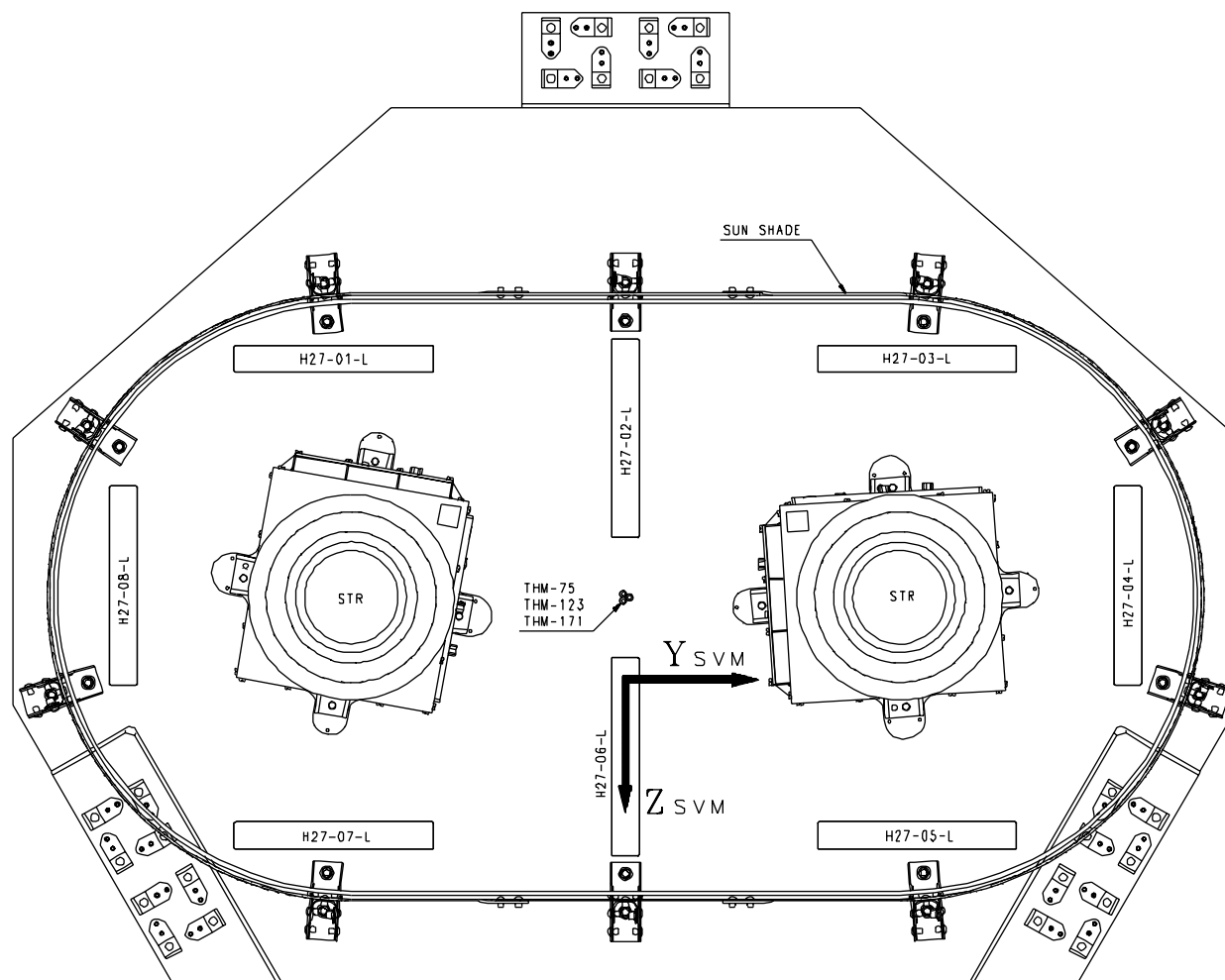

HERSCHEL PLANCK

DOC : H-P-TN-AI-0069

ISSUE : 05

DATE : 05/AUG/05

PAGE : 24 of 91

CLASS : DC

3.1.1-10a HERSCHEL Thrusters

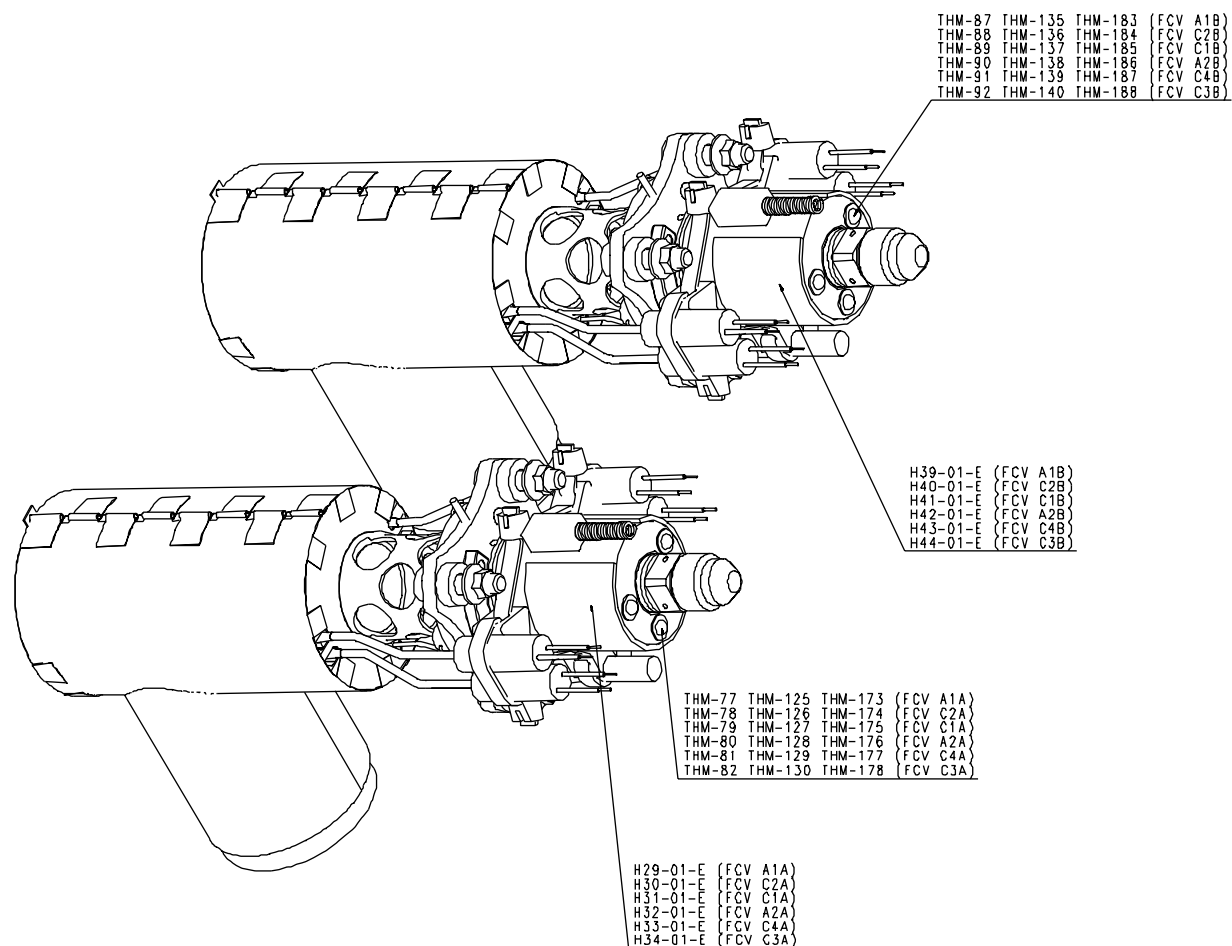

HERSCHEL PLANCK

3.1.1-10b HERSCHEL RCS unit heaters & thermistors

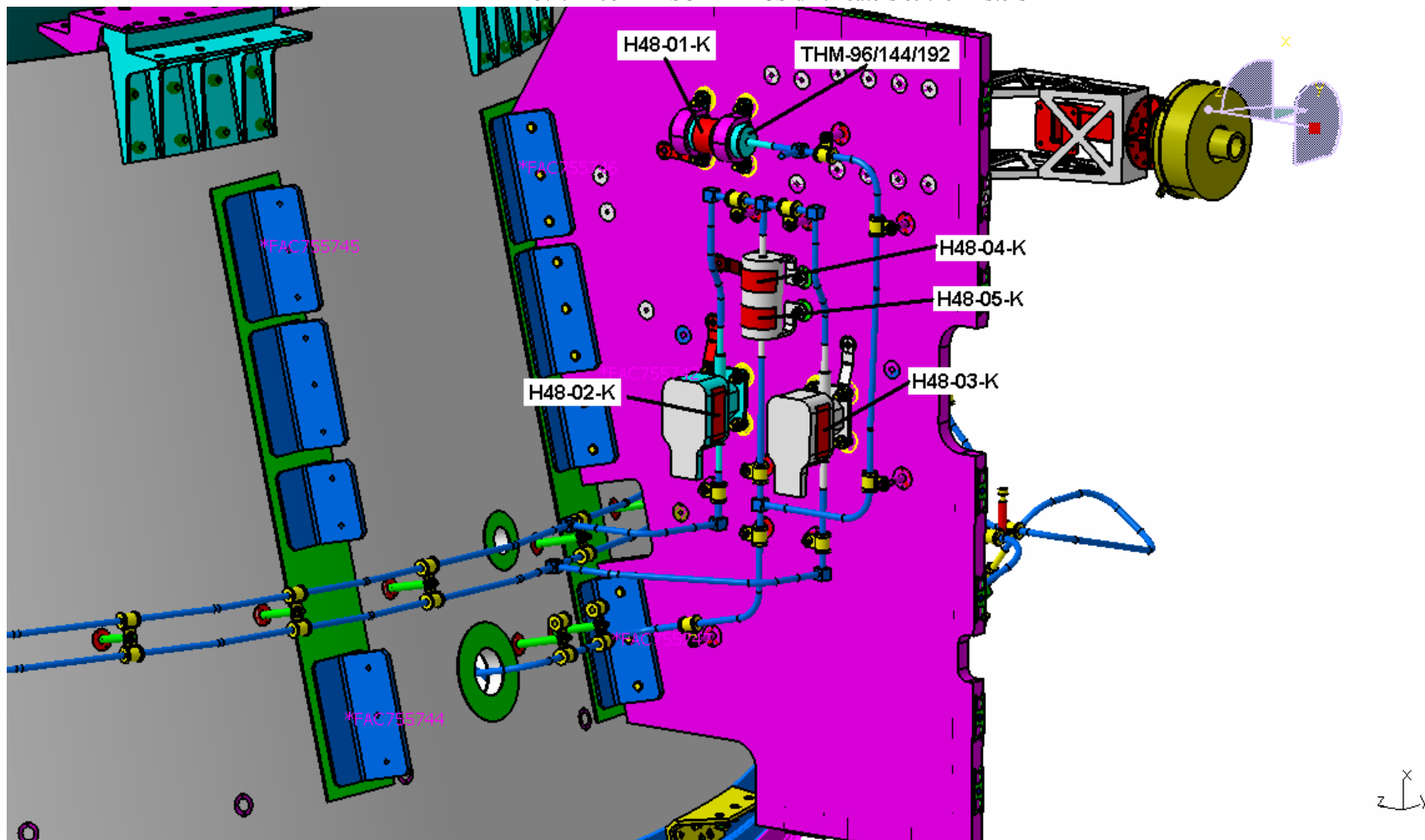

HERSCHEL PLANCK

Figure 3.1.1-11a HERSCHEL RCS

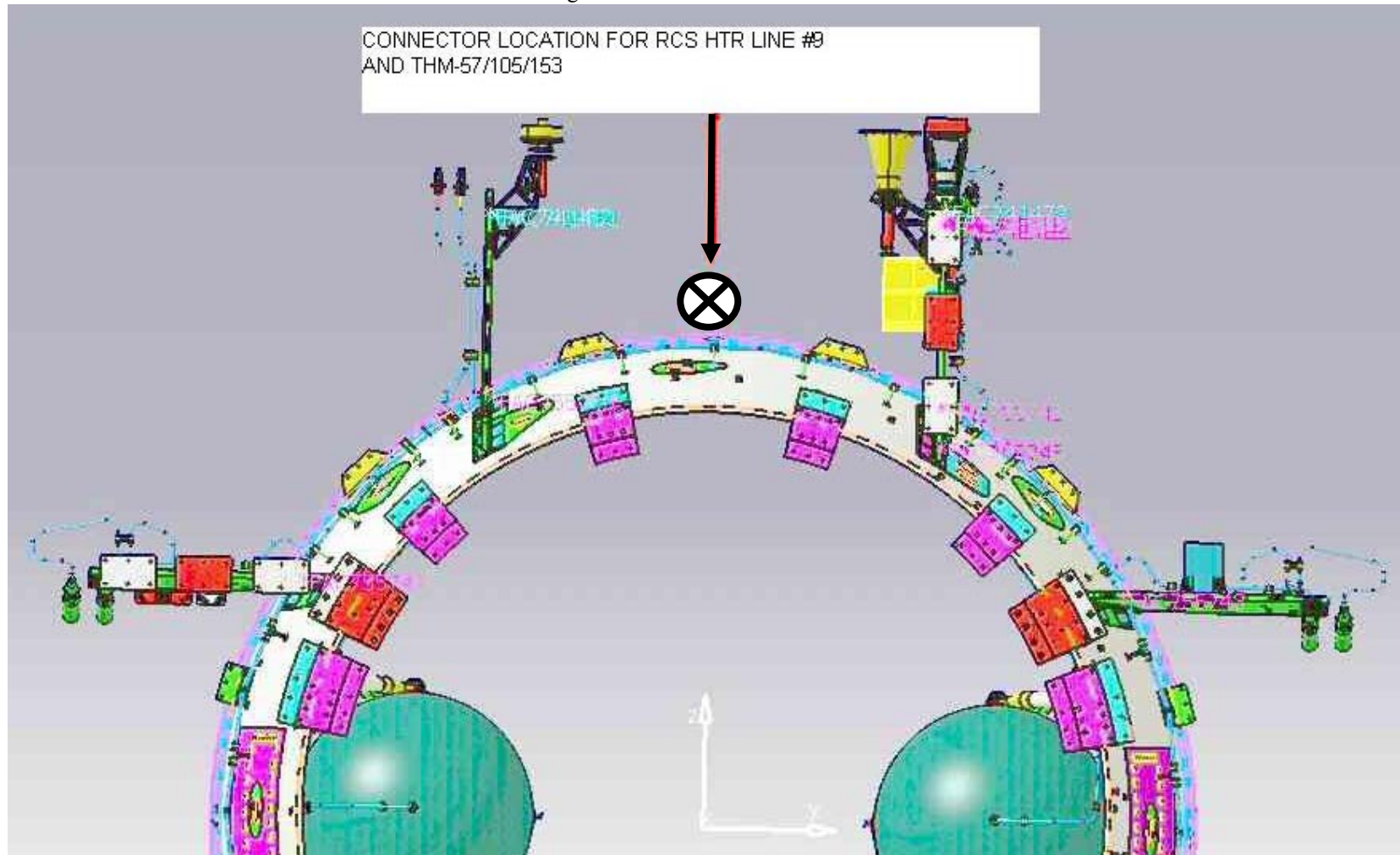

NOTE: FROM THE LOCATION OF THE CONNECTOR TO BE FORESEE 2 METERS EXTRA OF WIRES

HERSCHEL PLANCK

Figure 3.1.1-11b HERSCHEL RCS

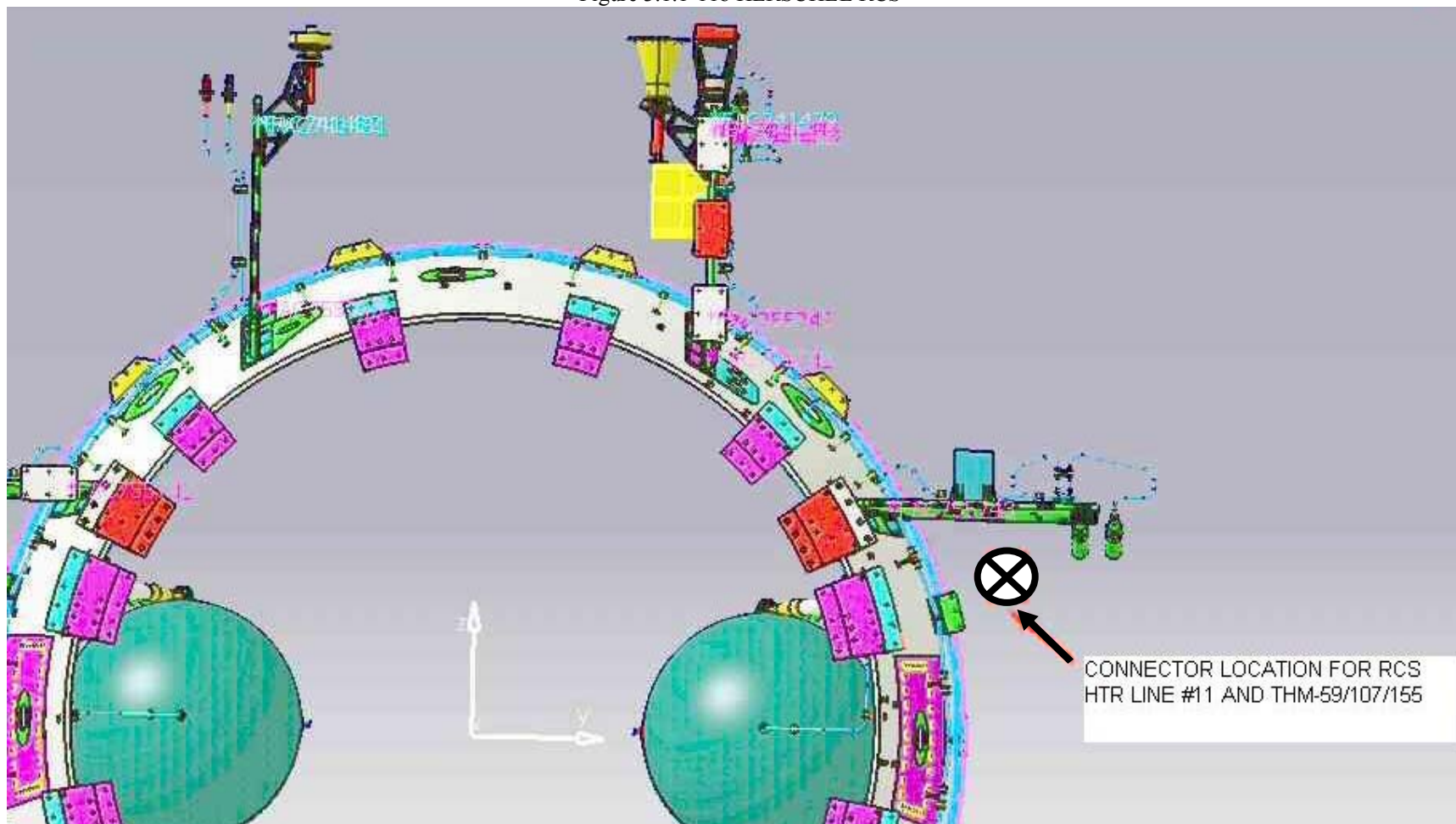

NOTE: FROM THE LOCATION OF THE CONNECTOR TO BE FORESEE 2 METERS EXTRA OF WIRES

HERSCHEL PLANCK

Figure 3.1.1-11c HERSCHEL RCS

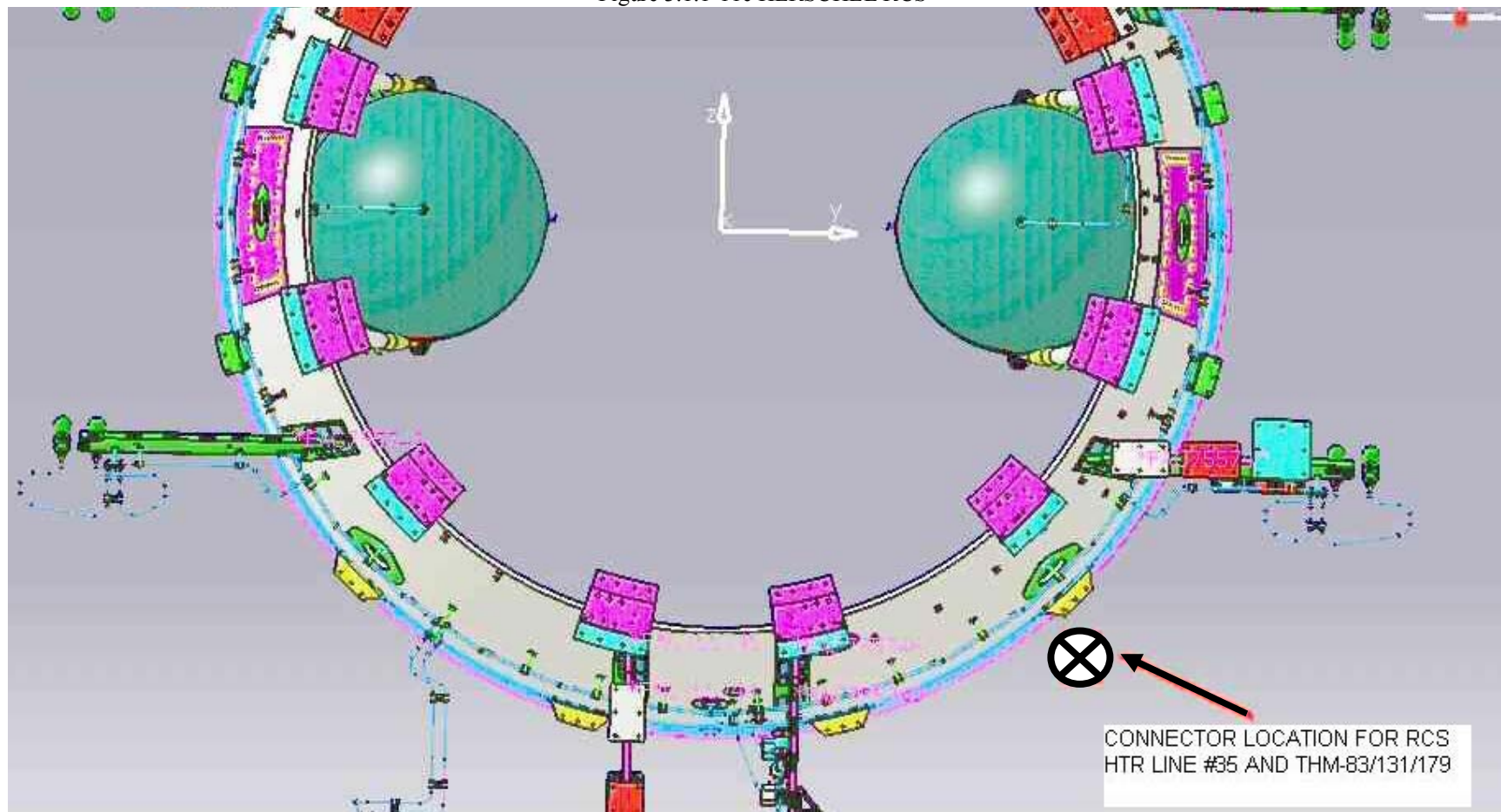

CONNECTOR LOCATION FOR RCS
HTR LINE #35 AND THM-83/131/179

NOTE: FROM THE LOCATION OF THE CONNECTOR TO BE FORESEE 2 METERS EXTRA OF WIRES

HERSCHEL PLANCK

DOC : H-P-TN-AI-0069
ISSUE : 05
DATE : 05/AUG/05
PAGE : 29 of 91
CLASS : DC

Figure 3.1.1-11d HERSCHEL RCS

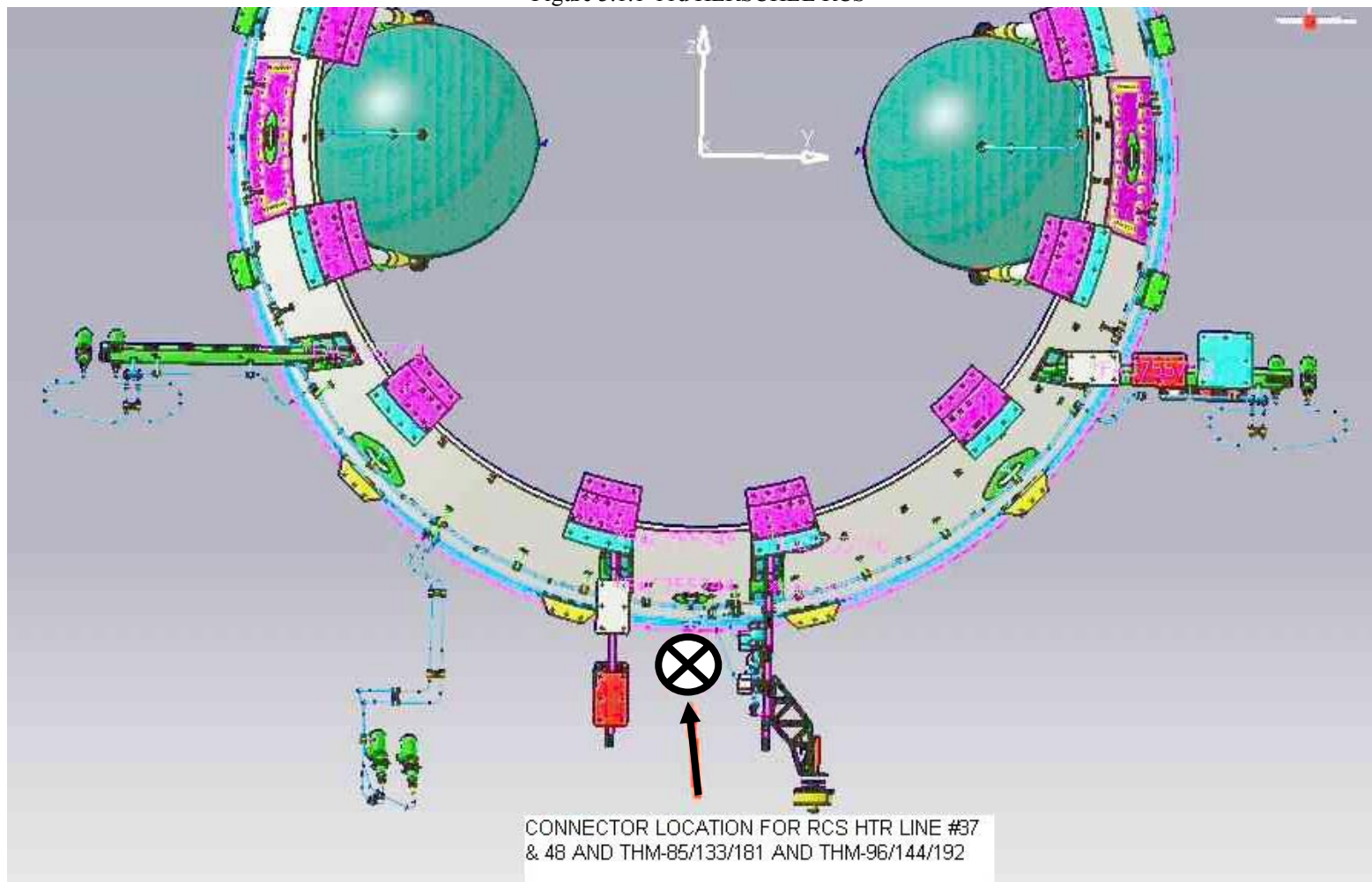

NOTE: FROM THE LOCATION OF THE CONNECTOR TO BE FORESEE 2 METERS EXTRA OF WIRES

HERSCHEL PLANCK

Figure 3.1.1-11e HERSCHEL RCS



CONNECTOR LOCATION FOR RCS
HTR LINE #45 AND THM-93/141/189

NOTE: FROM THE LOCATION OF THE CONNECTOR TO BE FORESEE 2 METERS EXTRA OF WIRES

HERSCHEL PLANCK

Figure 3.1.1-11fHERSCHEL RCS

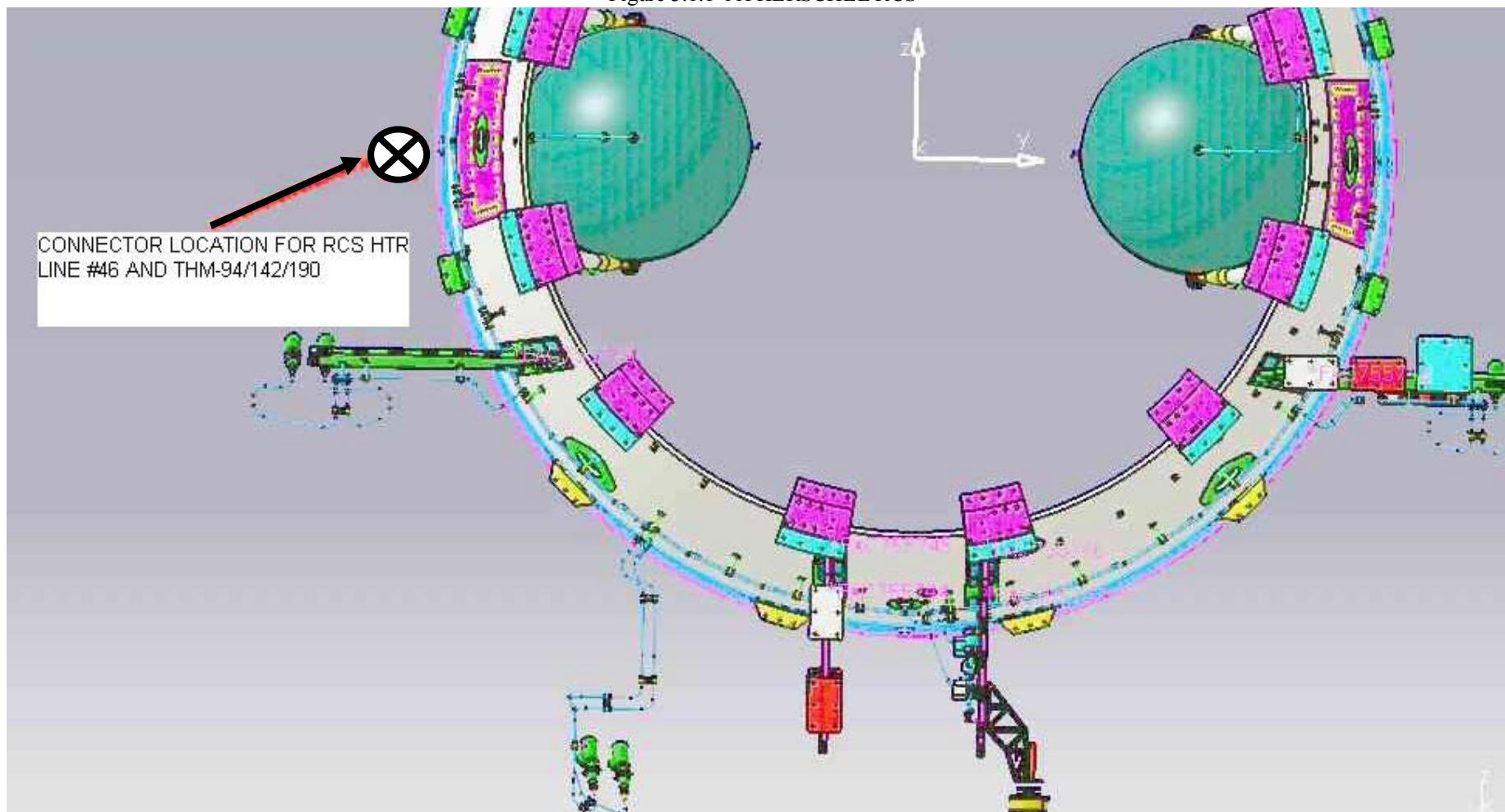

NOTE: FROM THE LOCATION OF THE CONNECTOR TO BE FORESEE 2 METERS EXTRA OF WIRES

HERSCHEL PLANCK

Figure 3.1.1-11g HERSCHEL RCS

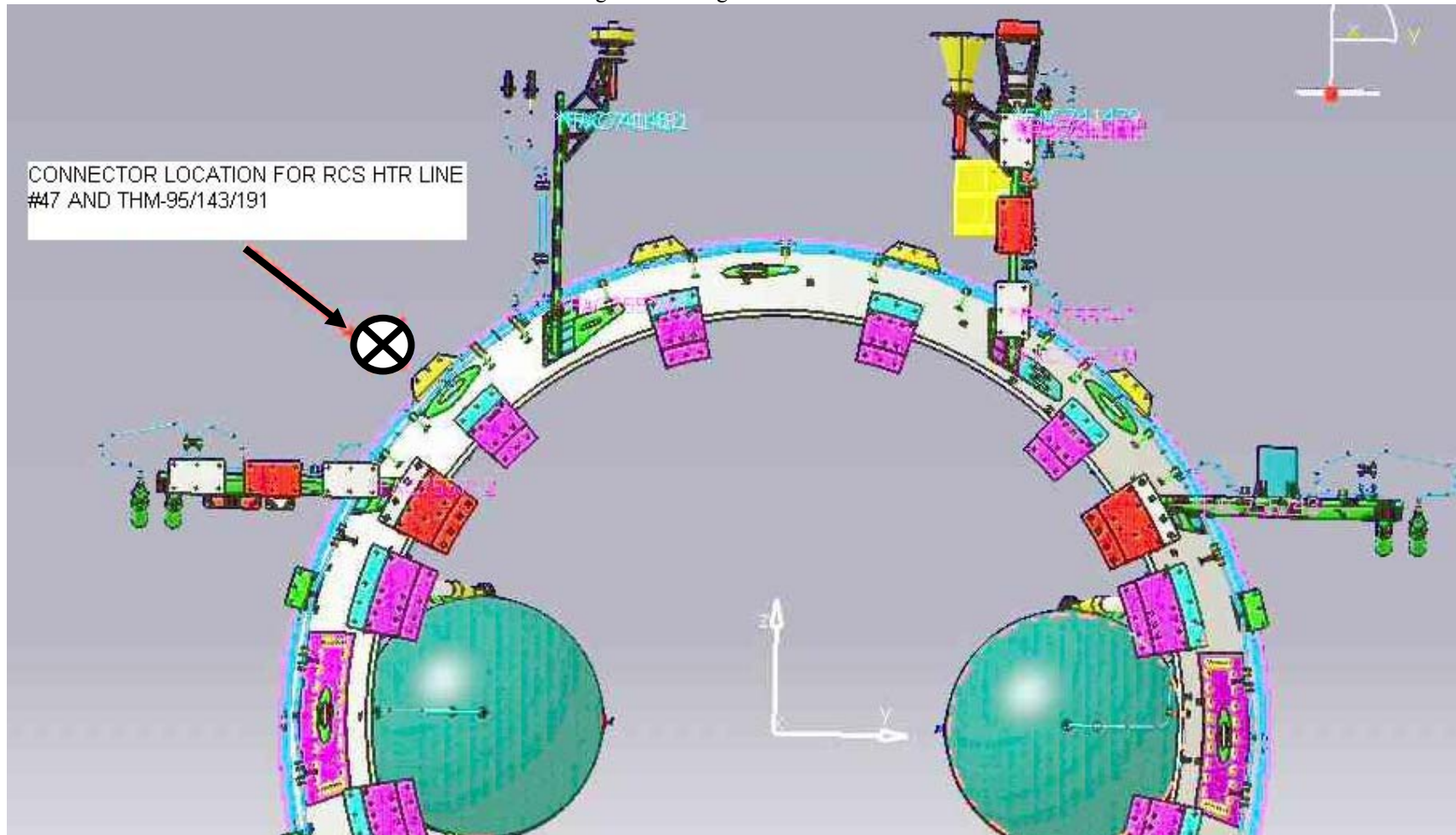

CONNECTOR LOCATION FOR RCS HTR LINE
#47 AND THM-95/143/191

NOTE: FROM THE LOCATION OF THE CONNECTOR TO BE FORESEE 2 METERS EXTRA OF WIRES

HERSCHEL PLANCK

DOC : H-P-TN-AI-0069
ISSUE : 05
DATE : 05/AUG/05
PAGE : 33 of 91
CLASS : DC

3.1.1-12 HERSCHEL Gyro

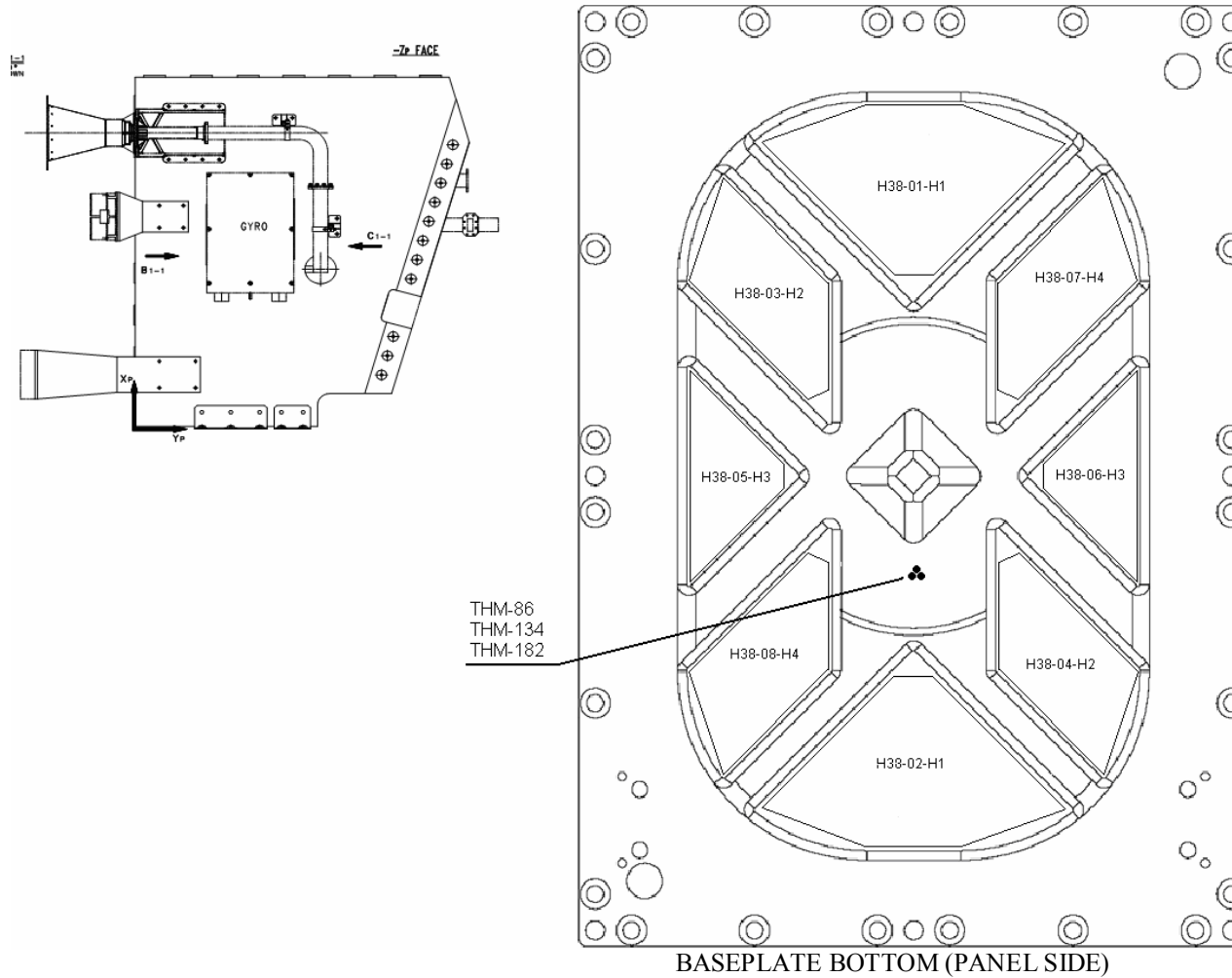

3.1.1.1 TCS Line circuit description

PANEL +Y+Z

Line 1: XPND 1 = 11.39 W

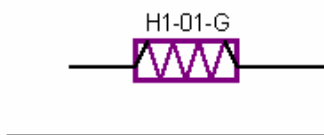

Line 2: XPND 2 = 11.39 W

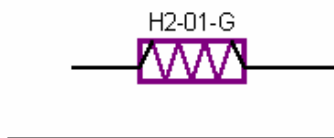

PANEL +Y

Line 3: internal heater of the battery = 14.9 W

PANEL +Y-Z

Line 5: FPSPU & FPDPU = 15.51 W + 15.51 W

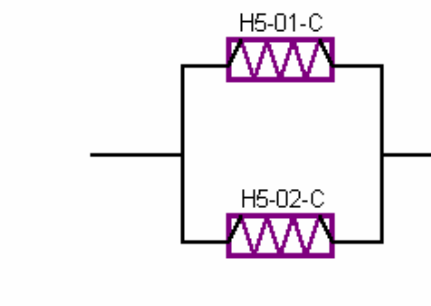

HERSCHEL PLANCK

Line 6: FPBOLC = 4.7 W + 4.7 W

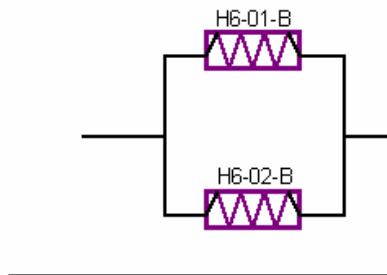

Line 8: FPDECMEC = 11.39 W + 11.39 W + 4.7 W

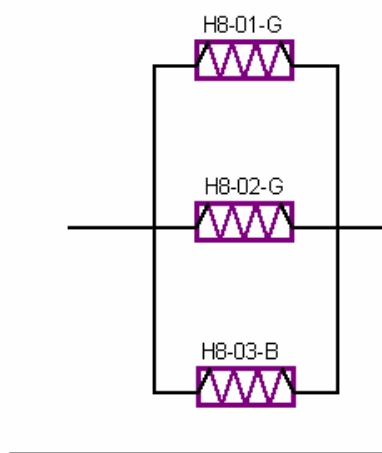

PANEL -Z

Line 10: CCU, HSDCU, HSFCU = 15.51 W + 8.1 W + 8.1 W + 8.1 W + 4.7 W

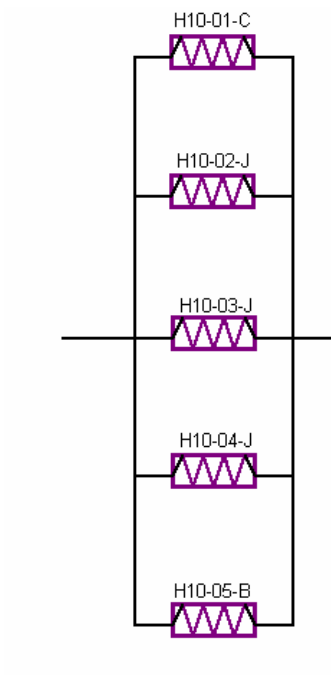

HERSCHEL PLANCK

PANEL -Y-Z

Line 12: FHWOV = 11.39 W + 11.39 W

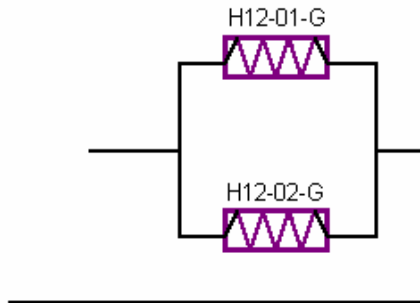

Line 13: FHHRV = 8.1 W + 8.1 W + 11.39 W + 11.39 W

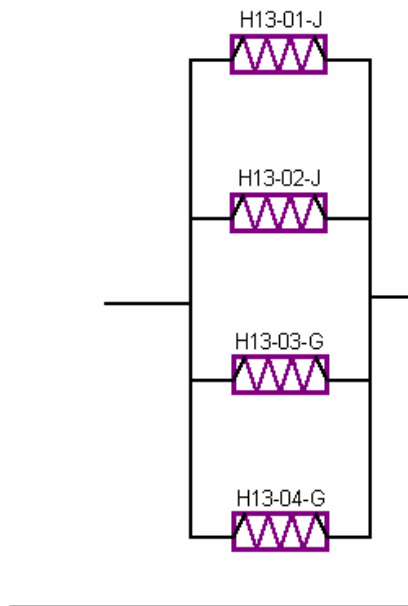

HERSCHEL PLANCK

Line 28: FHIFV = 11.4 W

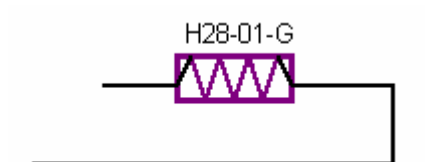

HERSCHEL PLANCK

Line 14: FHFCU = 4.7 W + 11.39 W + 4.7 W

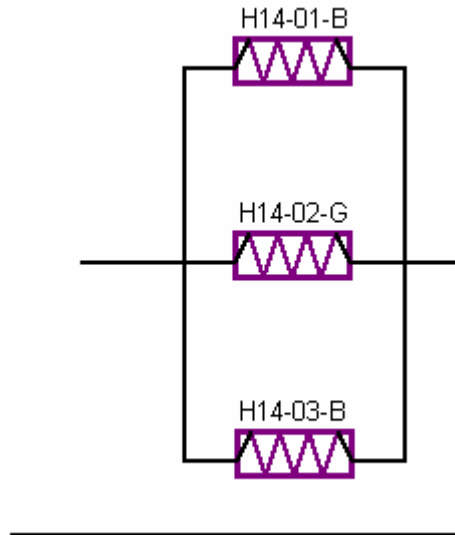

Line 15: FHWEV, FHICU = 11.39 W + 8.1 W + 8.1 W + 8.1 W

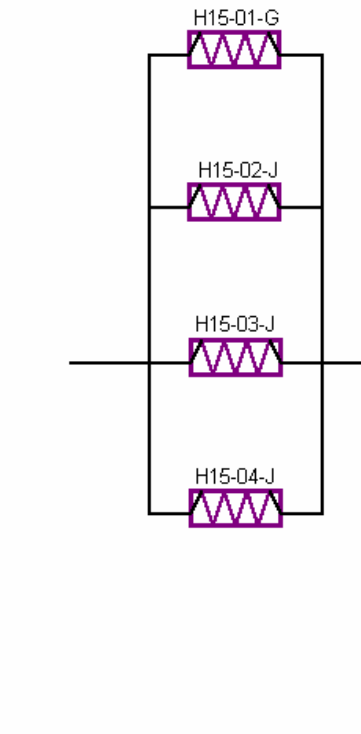

HERSCHEL PLANCK

PANEL - Y

Line 16: FHWOH = 8.1 W + 8.1 W + 8.1 W + 8.1 W

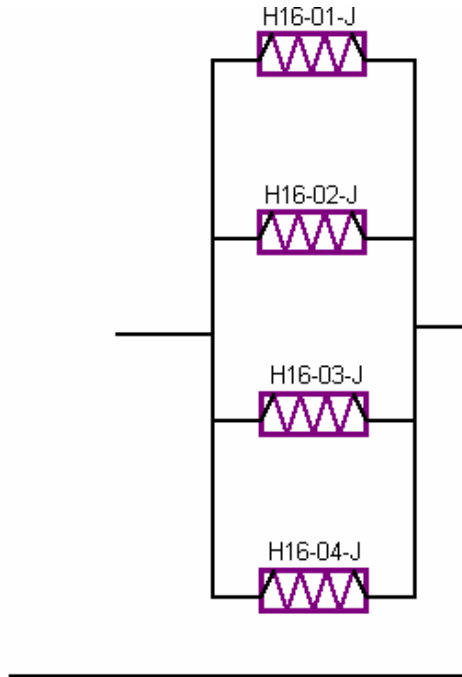

Line 17: FHWEH = 8.1 W + 8.1 W + 8.1 W + 8.1 W

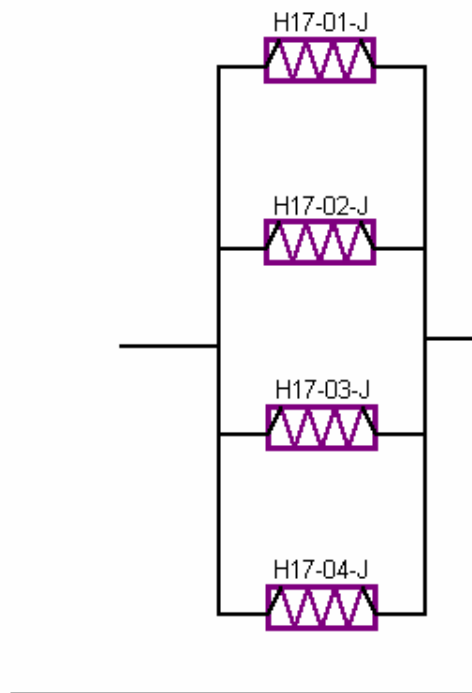

HERSCHEL PLANCK

Line 18: FHHRH = 8.1 W + 8.1 W + 11.39 W + 11.39 W

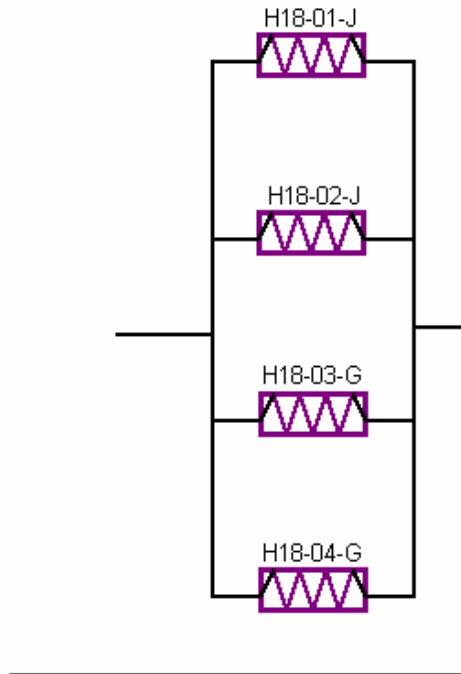

Line 19: FHLCU, FHIFH = 8.1 W + 8.1 W + 4.7 W

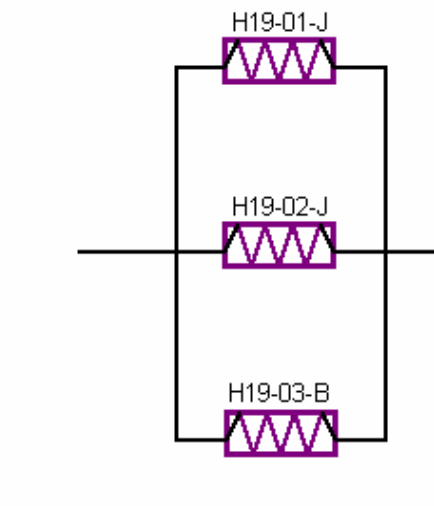

HERSCHEL PLANCK

Line 20: FHLSU = 8.1 W + 8.1 W + 4.7 W + 8.1 W

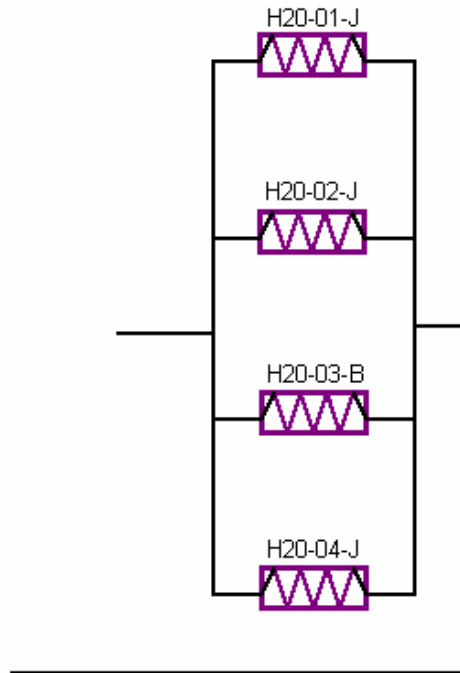

HERSCHEL PLANCK

PANEL -Y+Z

Line 21: RWL 2 = 11.39 W

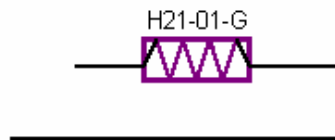

Line 22: RWL 4 = 11.39 W

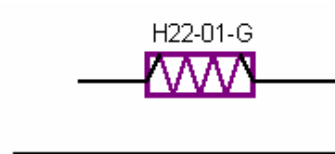

Line 23: RWL1 = 11.39 W

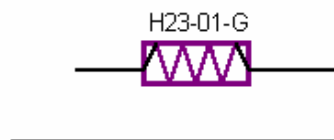

Line 24: RWL 3 = 11.39 W

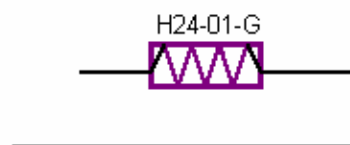

HERSCHEL PLANCK

TANK's

Line 25: TANK +Y = 0.77 W +0.77 W +0.77 W +0.77 W +0.77 W +0.77 W +0.77 W = **5.4 W**

REMARKS:

These Heater connections must be performed outside of the TANK MLI blankets

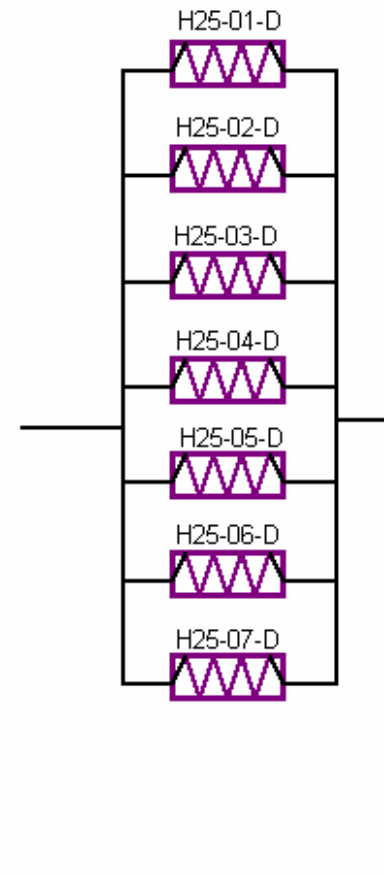

HERSCHEL PLANCK

Line 26: TANK -Y = 0.77 W +0.77 W +0.77 W +0.77 W +0.77 W +0.77 W +0.77 W = **5.4 W**

REMARKS:

These Heater connections must be performed outside of the TANK MLI blankets

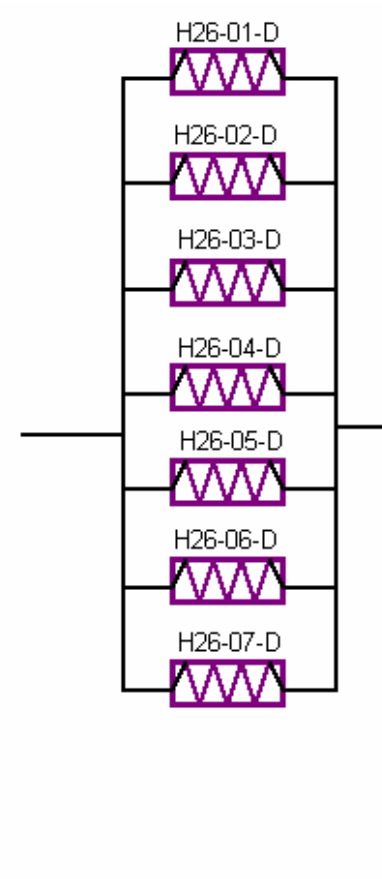

HERSCHEL PLANCK

STAR TRACKERS

Line 27: STAR TRACKER -Y = 2.64 W +2.64 W +2.64 W +2.64 W +2.64 W +2.64 W +2.64 W +2.64 W

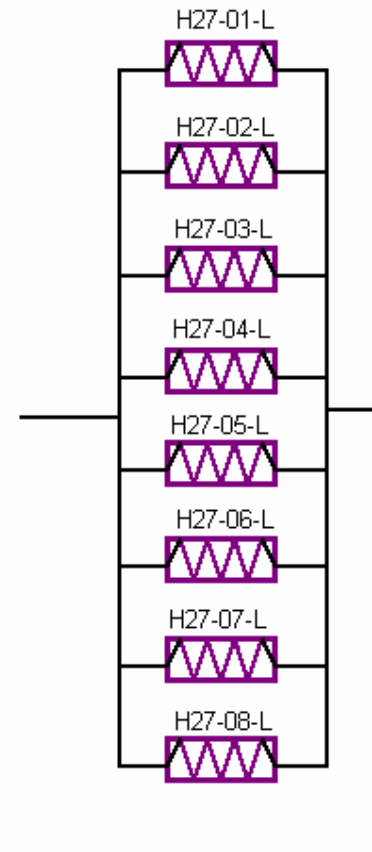

THRUSTER FCV-A

Line 29: FCV A1A = 1.43 W

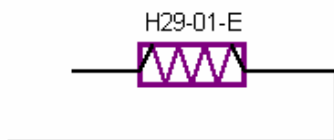

Line 30: FCV C2A = 1.43 W

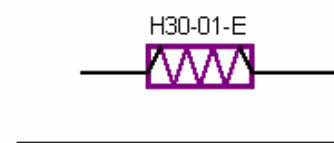

Line 31: FCV C1A = 1.43 W



Line 32: FCV A2A = 1.43 W

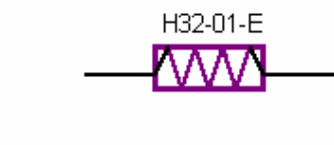

Line 33: FCV C4A = 1.43 W

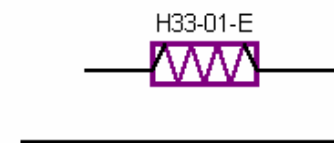

Line 34: FCV C3A = 1.43 W

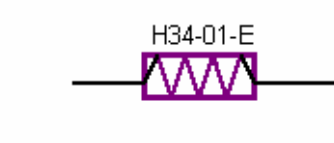

HERSCHEL PLANCK

TANK's

Line 36: TANK +Y/-Y = 0.77 W + 0.77 W = 1.54 W

REMARKS:

These Heater connections must be performed outside of the TANK MLI blankets

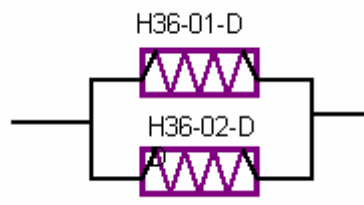

SHEAR PANEL +Z(+Y)

Line 38: GYRO = 9.85 W + 9.85 W + 4.86 W + 4.86 W + 3.04 W + 3.04 W + 4.86 W + 4.86 W

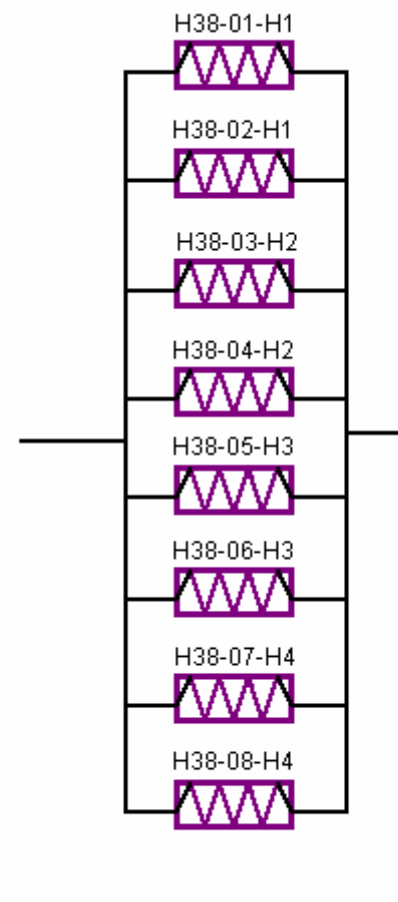

THRUSTER FCV-B

Line 39: FCV A1B = 1.43 W

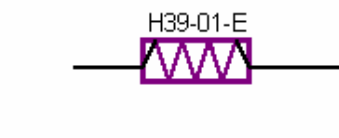

Line 40: FCV C2B = 1.43 W



Line 41: FCV C1B = 1.43 W

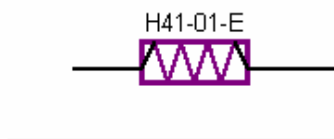

Line 42: FCV A2B = 1.43 W

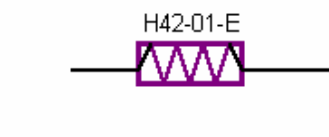

Line 43: FCV C4B = 1.43 W

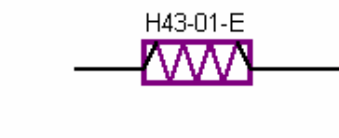

Line 44: FCV C3B = 1.43 W

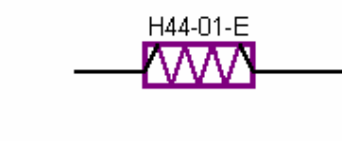

HERSCHEL PLANCK

RCS UNITS

Line 48: RCS Units = 1.4 W + 1.4 W + 1.4 W + (0.35 W + 0.35 W)

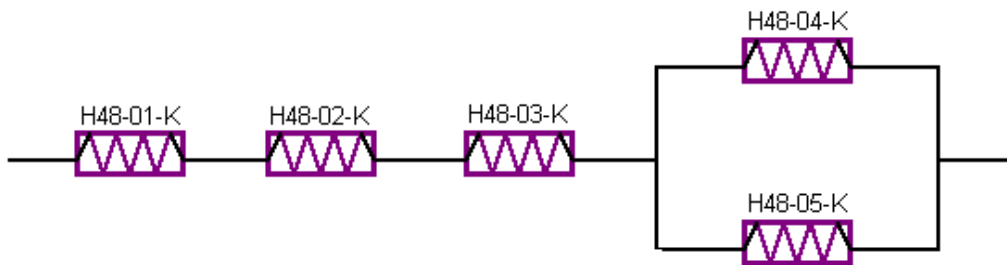

REMARKS:

Heater H48-01-K must be connected to positive voltage (+27V).

HERSCHEL PLANCK

3.1.2 PLANCK TCS Heater lines description

Table 3.1.2-1

Line N.	Location	Line Name	Reference Unit	Total Heater	Heater Type	Heater Id.	Resistance [ohm]	Electrical Connection Type	Equivalent Resistance [ohm]	Heater Line commanded by THM	Equivalent Power @27 V [W]	Reference Figure
1	+Z	HTR5427S	Star Tracker 1	1	B	P1-01-B (M+R)	155	-	155	49/97/145	4.7	3.1.2-1
2		HTR5527S	Star Tracker 2	1	B	P2-01-B (M+R)	155	-	155	50/98/146	4.7	
3		HTR13S	DPU 1	2	G	P3-01-G (M+R)	64	PARALLEL	32	51/99/147	22.8	
4					G	P3-02-G (M+R)	64					
5	+Y	HTR14S	DPU 2	2	G	P4-01-G (M+R)	64	PARALLEL	32	52/100/148	22.8	3.1.2-2
					G	P4-02-G (M+R)	64					
6	+Y	HTR205S	REU	4	C	P5-01-C (M+R)	47	PARALLEL	11.75	53/101/149	62.0	3.1.2-2
					C	P5-02-C (M+R)	47					
					C	P5-03-C (M+R)	47					
					C	P5-04-C (M+R)	47					
35	+Y	HTR220S	CCU & CEU (4KCDE)	6	B	P6-01-B (M+R)	155	PARALLEL	13.88	54/102/150	52.5	3.1.2-2
					B	P6-02-B (M+R)	155					
					C	P6-03-C (M+R)	47					
					J	P6-04-J (M+R)	90					
					J	P6-05-J (M+R)	90					
					G	P6-06-G (M+R)	64					
7	SCC/SCE PANELS	HTR202S	CAU	4	J	P35-01-J (M+R)	90	PARALLEL	18.7	83/131/179	39.0	3.1.2-8
					J	P35-02-J (M+R)	90					
					G	P35-03-G (M+R)	64					
					G	P35-04-G (M+R)	64					
8	SCC/SCE PANELS	HTRHP7NS	Heat Pipe	3	F	P7-01-F (M+R)	28.04	PARALLEL	9.35	55/103/151	78	3.1.2-10
					F	P7-02-F (M+R)	28.04					
					F	P7-03-F (M+R)	28.04					
9	SCC/SCE PANELS	HTRHP8NS	Heat Pipe	3	F	P8-01-F (M+R)	28.04	PARALLEL	9.35	55/103/151	78	3.1.2-10
					F	P8-02-F (M+R)	28.04					
					F	P8-03-F (M+R)	28.04					
					F	P9-01-F (M+R)	28.04					
					F	P9-02-F (M+R)	28.04					
9	SCC/SCE PANELS	HTRHP9S	Heat Pipe	5	F	P9-03-F (M+R)	28.04	PARALLEL / SERIES	8.01	55/103/151	91	3.1.2.8
					F	P9-04-F (M+R)	28.04					
					F	P9-05-F (M+R)	28.04					

Line	Location	Line Name	Reference Unit	Total	Heater	Heater Id.	Resistanc	Electrical	Equivalent	Heater Line	Equivalent	Reference Figure
------	----------	-----------	----------------	-------	--------	------------	-----------	------------	------------	-------------	------------	------------------

HERSCHEL PLANCK

N.				Heater	Type		e [ohm]	Connection Type	Resistance [ohm]	commanded by THM	Power @27 V [W]	
10	SCC/SCE PANELS	HTRHP10S	Heat Pipe	5	F	P10-01-F (M+R)	28.04	PARALLEL / SERIES	8.01	55/103/151	91	3.1.2-10
					F	P10-02-F (M+R)	28.04					
					F	P10-03-F (M+R)	28.04					
					F	P10-04-F (M+R)	28.04					
					F	P10-05-F (M+R)	28.04					
11		HTRHP11S	Heat Pipe	5	F	P11-01-F (M+R)	28.04	PARALLEL / SERIES	8.01		91	
					F	P11-02-F (M+R)	28.04					
					F	P11-03-F (M+R)	28.04					
					F	P11-04-F (M+R)	28.04					
					F	P11-05-F (M+R)	28.04					
12		HTRHP12S	Heat Pipe	5	F	P12-01-F (M+R)	28.04	PARALLEL / SERIES	8.01		91	3.1.2-9
					F	P12-02-F (M+R)	28.04					
					F	P12-03-F (M+R)	28.04					
					F	P12-04-F (M+R)	28.04					
					F	P12-05-F (M+R)	28.04					
13	HTRHP13S	Heat Pipe	5	F	P13-01-F (M+R)	28.04	PARALLEL / SERIES	8.01	91			
				F	P13-02-F (M+R)	28.04						
				F	P13-03-F (M+R)	28.04						
				F	P13-04-F (M+R)	28.04						
				F	P13-05-F (M+R)	28.04						
14	He tank -Z	TR910NS	He tank -Z	2	M	P14-01-M (M+R)	700	PARALLEL	350	62/110/158	2.08	3.1.2-15
	He tank +Y		1	M	P14-03-M (M+R)	700	700		1.04			
	He tank +Z		1	M	P14-04-M (M+R)	700	700		1.04			
15	Sub platform	HTR522S	PAU	1	J	P15-01-J (M+R)	90	-	90	63/111/159	8.1	3.1.2-12
16	SH. PAN. +Z+Y	HTR203S	CRU	2	J	P16-01-J (M+R)	90	PARALLEL	56.9	64/112/160	12.8	3.1.2-11
					B	P16-02-B (M+R)	155					
17		Spare	-	-	-	-	-	-	-	-	-	-
18		Spare	-	-	-	-	-	-	-	-	-	-
19		Spare	-	-	-	-	-	-	-	-	-	-
20	PROP. TANKS	HTR9250NS	TANK +Z-Y/+Z-Y/-Z	3	D	P20-01-D (M+R)	945	PARALLEL (**)	315	-	2.31	3.1.2-5
					D	P20-02-D (M+R)	945					
					D	P20-03-D (M+R)	945					

(**) **REMARKS:** These Heater connections must be performed outside of the TANK MLI blankets

HERSCHEL PLANCK

Line N.	Location	Line Name	Reference Unit	Total Heater	Heater Type	Heater Id.	Resistance [ohm]	Electrical Connection Type	Equivalent Resistance [ohm]	Heater Line commanded by THM	Equivalent Power @27 V [W]	Reference Figure
21	PROP. TANKS	HTR920NS	TANK +Z+Y	7	D	P21-01-D (M+R)	945	PARALLEL (**)	135	69/117/165	5.4	
					D	P21-02-D (M+R)	945					
					D	P21-03-D (M+R)	945					
					D	P21-04-D (M+R)	945					
					D	P21-05-D (M+R)	945					
					D	P21-06-D (M+R)	945					
					D	P21-07-D (M+R)	945					
22	PROP. TANKS	HTR925NS	TANK +Z-Y	7	D	P22-01-D (M+R)	945	PARALLEL (**)	135	70/118/166	5.4	3.1.2-5
					D	P22-02-D (M+R)	945					
					D	P22-03-D (M+R)	945					
					D	P22-04-D (M+R)	945					
					D	P22-05-D (M+R)	945					
					D	P22-06-D (M+R)	945					
					D	P22-07-D (M+R)	945					
23	PROP. TANKS	HTR930NS	TANK -Z	7	D	P23-01-D (M+R)	945	PARALLEL (**)	135	71/119/167	5.4	
					D	P23-02-D (M+R)	945					
					D	P23-03-D (M+R)	945					
					D	P23-04-D (M+R)	945					
					D	P23-05-D (M+R)	945					
					D	P23-06-D (M+R)	945					
					D	P23-07-D (M+R)	945					
24	1N THRUSTER	HTR8508NS	1N FCV A1A on -Y +Z (+Z side)	1	E	P24-01-E (M+R)	310	-	310	72/120/168	2.35	3.1.2-6
25		HTR8708NS	1N FCV B1A on -Y +Z (-Z side)	1	E	P25-01-E (M+R)	310	-	310	73/121/169	2.35	
26	20N THRUSTER	HTR1133NS	FCV D1A	1	N	P26-01-E (M+R)	510	-	10	74/122/170	1.43	3.1.2-7
27		HTR1233NS	FCV D2A	1	N	P27-01-E (M+R)	510	-	510	75/123/171	1.43	
28		HTR1333NS	FCV F1A	1	N	P28-01-E (M+R)	510	-	510	76/124/172	1.43	
29		HTR1433NS	FCV F2A	1	N	P29-01-E (M+R)	510	-	510	77/125/173	1.43	
30		HTR1533NS	FCV U1A	1	N	P30-01-E (M+R)	510	-	510	78/126/174	1.43	
31		HTR1733NS	FCV U2A	1	N	P31-01-E (M+R)	510	-	510	79/127/175	1.43	

(**) **REMARKS:** These Heater connections must be performed outside of the TANK MLI blankets

HERSCHEL PLANCK

Line N.	Location	Line Name	Reference Unit	Total Heater	Heater Type	Heater Id.	Resistance [ohm]	Electrical Connection Type	Equivalent Resistance [ohm]	Heater Line commanded by THM	Equivalent Power @27 V [W]	Reference Figure
32	RCS	HTR1850NS	PT	1	K	P32-01-K (M+R)	42.5	SERIES/ PARALLEL	148.8	80/128/176	4.9	3.1.2-7b
			LV1	1	K	P32-02-K (M+R)	42.5					
			LV2	1	K	P32-03-K (M+R)	42.5					
			LF	2	K	P32-04-K (M+R)	42.5					
					K	P32-05-K (M+R)	42.5					
33		HTR1809NS	PIPES		WIRE			SERIES	See H-P-TN-AI-0104	81/129/177	See H-P-TN-AI-0104	See H-P-TN-AI-0104
34		HTR1805NS	PIPES		WIRE			SERIES	See H-P-TN-AI-0104	82/130/178	See H-P-TN-AI-0104	See H-P-TN-AI-0104
36	+Z+Y	HTR103S	REBA 1&2	2	G	P36-01-G (M+R)	64	PARALLEL	32	84/132/180	22.8	3.1.2-3
					G	P36-02-G (M+R)	64					
37	+Z-Y	HTR703S	BATTERY (*)	(*)	(*)	(*)	(*)	(*)	(*)	85/133/181	14.9 (*)	3.1.2-4
38	1N THRUSTER	HTR8608NS	1N FCV A1B on -Y+Z (+Z side)	1	E	P38-01-E (M+R)	310	-	310	86/134/182	2.35	3.1.2-6
39		HTR8808NS	1N FCV B1B on -Y+Z (-Z side)	1	E	P39-01-E (M+R)	310	-	310	87/135/183	2.35	
40	20N THRUSTER	HTR1134NS	FCV D1B	1	N	P40-01-E (M+R)	510	-	510	88/136/184	1.43	3.1.2-7
41		HTR1234NS	FCV D2B	1	N	P41-01-E (M+R)	510	-	510	89/137/185	1.43	
42		HTR1334NS	FCV F1B	1	N	P42-01-E (M+R)	510	-	510	90/138/186	1.43	
43		HTR1434NS	FCV F2B	1	N	P43-01-E (M+R)	510	-	510	91/139/187	1.43	
44		HTR1534NS	FCV U1B	1	N	P44-01-E (M+R)	510	-	510	92/140/188	1.43	
45		HTR1734NS	FCV U2B	1	N	P45-01-E (M+R)	510	-	510	93/141/189	1.43	
46	RCS	HTR1815NS	PIPES		WIRE			SERIES	See H-P-TN-AI-0104	94/142/190	See H-P-TN-AI-0104	See H-P-TN-AI-0104
47	RCS	HTR1867NS	PIPES		WIRE			SERIES	See H-P-TN-AI-0104	95/143/191	See H-P-TN-AI-0104	See H-P-TN-AI-0104
48	RCS	HTR1884NS	PIPES		WIRE			SERIES	See H-P-TN-AI-0104	96/144/192	See H-P-TN-AI-0104	See H-P-TN-AI-0104

(*) INTERNAL HEATER

HERSCHEL PLANCK

Figure 3.1.2-1 PLANCK +Z Panel

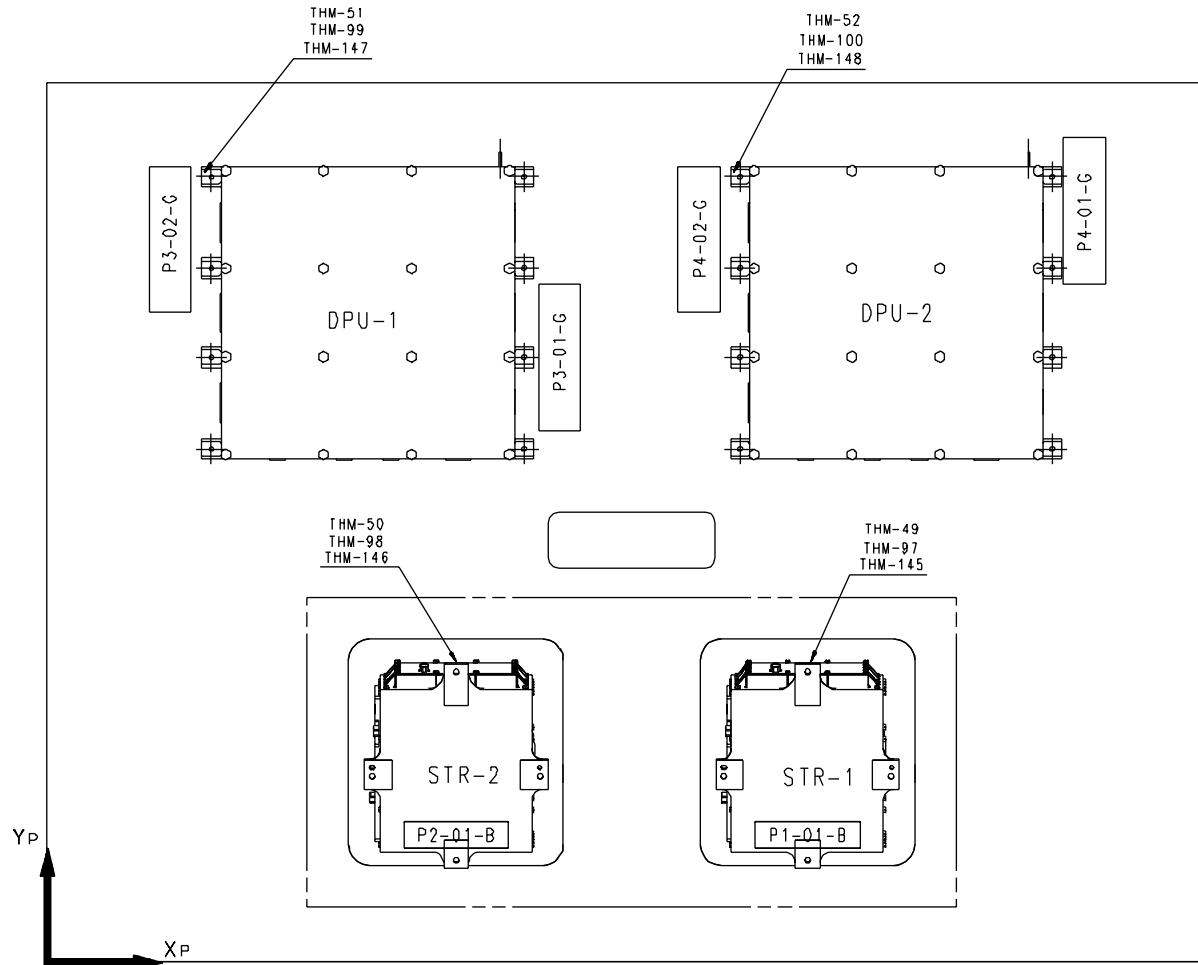

HERSCHEL PLANCK

Figure 3.1.2-2 PLANCK +Y Panel

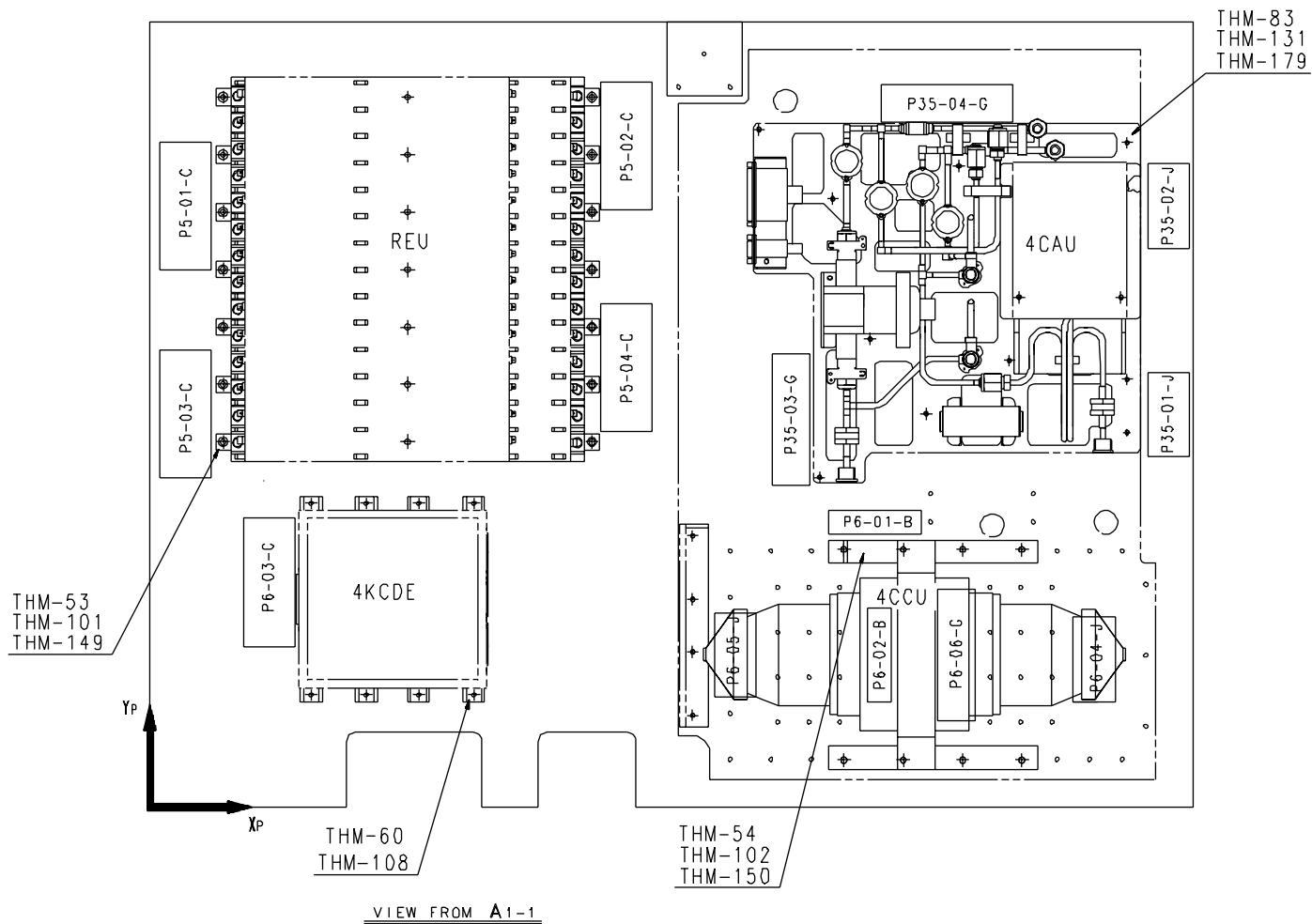

HERSCHEL PLANCK

DOC : H-P-TN-AI-0069
ISSUE : 05
DATE : 05/AUG/05
PAGE : 56 of 91
CLASS : DC

Figure 3.1.2-3 PLANCK +Z+Y Panel

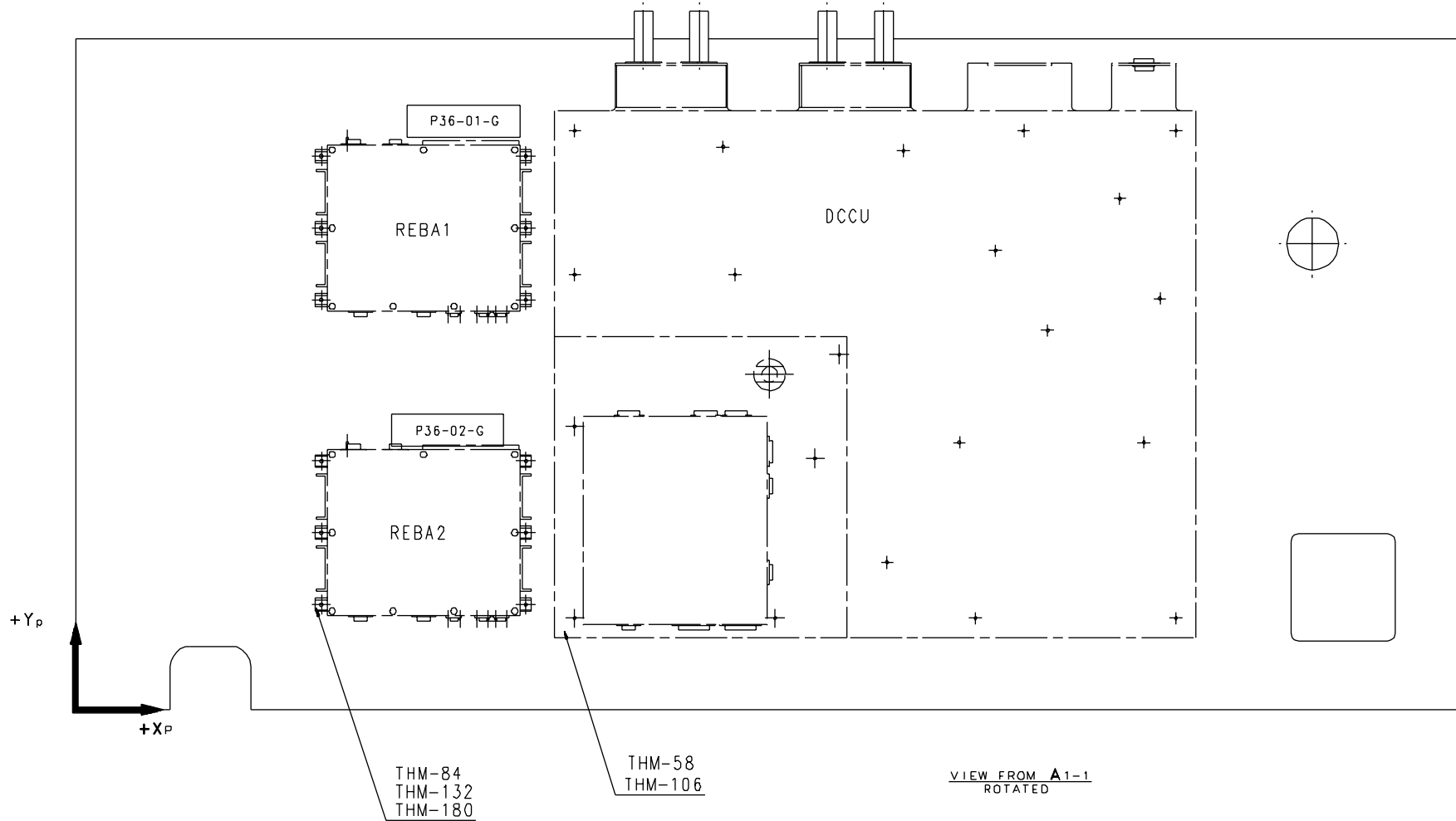

HERSCHEL PLANCK

DOC : H-P-TN-AI-0069
ISSUE : 05
DATE : 05/AUG/05
PAGE : 57 of 91
CLASS : DC

Figure 3.1.2-4 PLANCK +Z-Y Panel

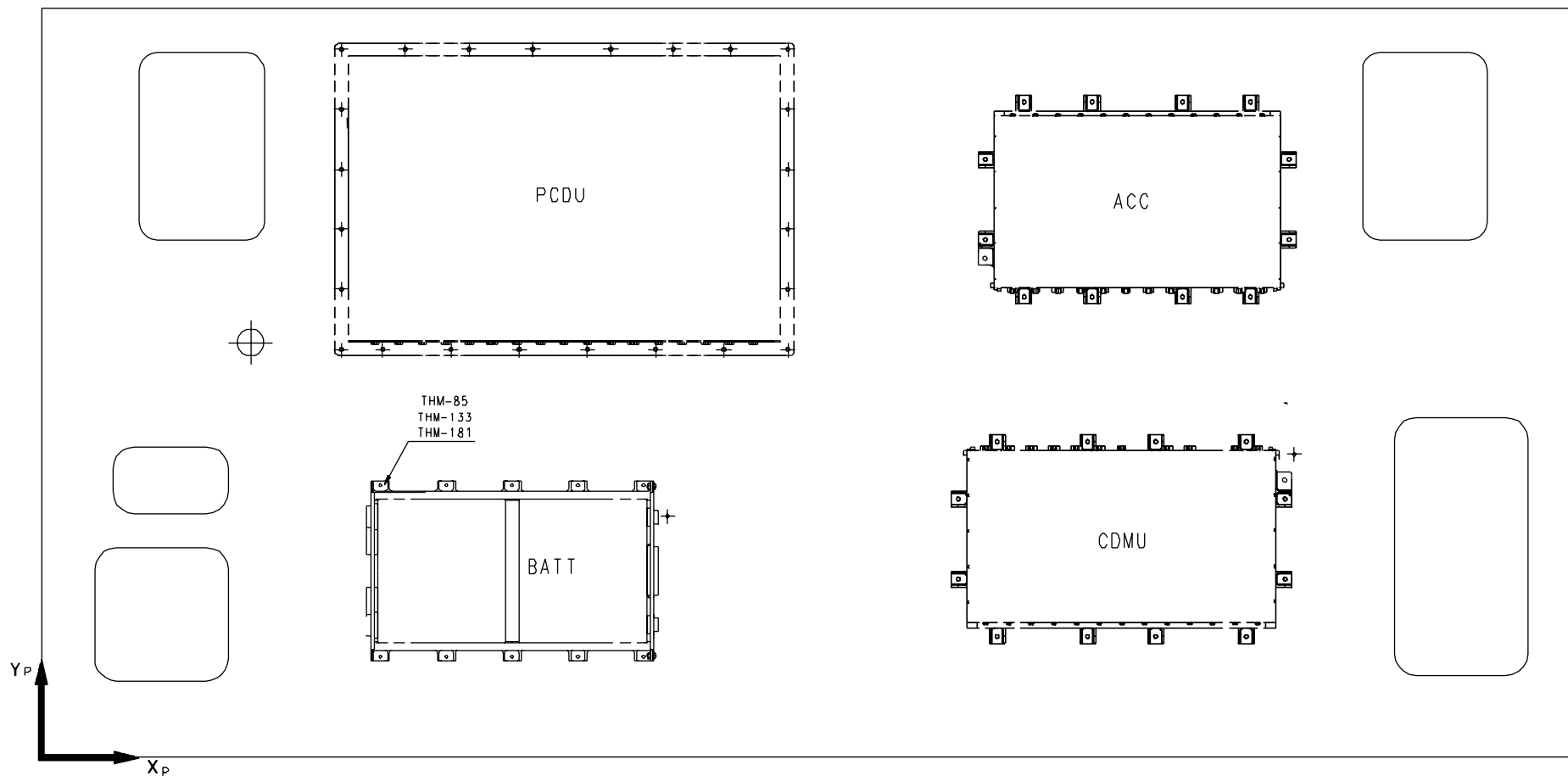

HERSCHEL PLANCK

Figure 3.1.2-5 PLANCK Tanks

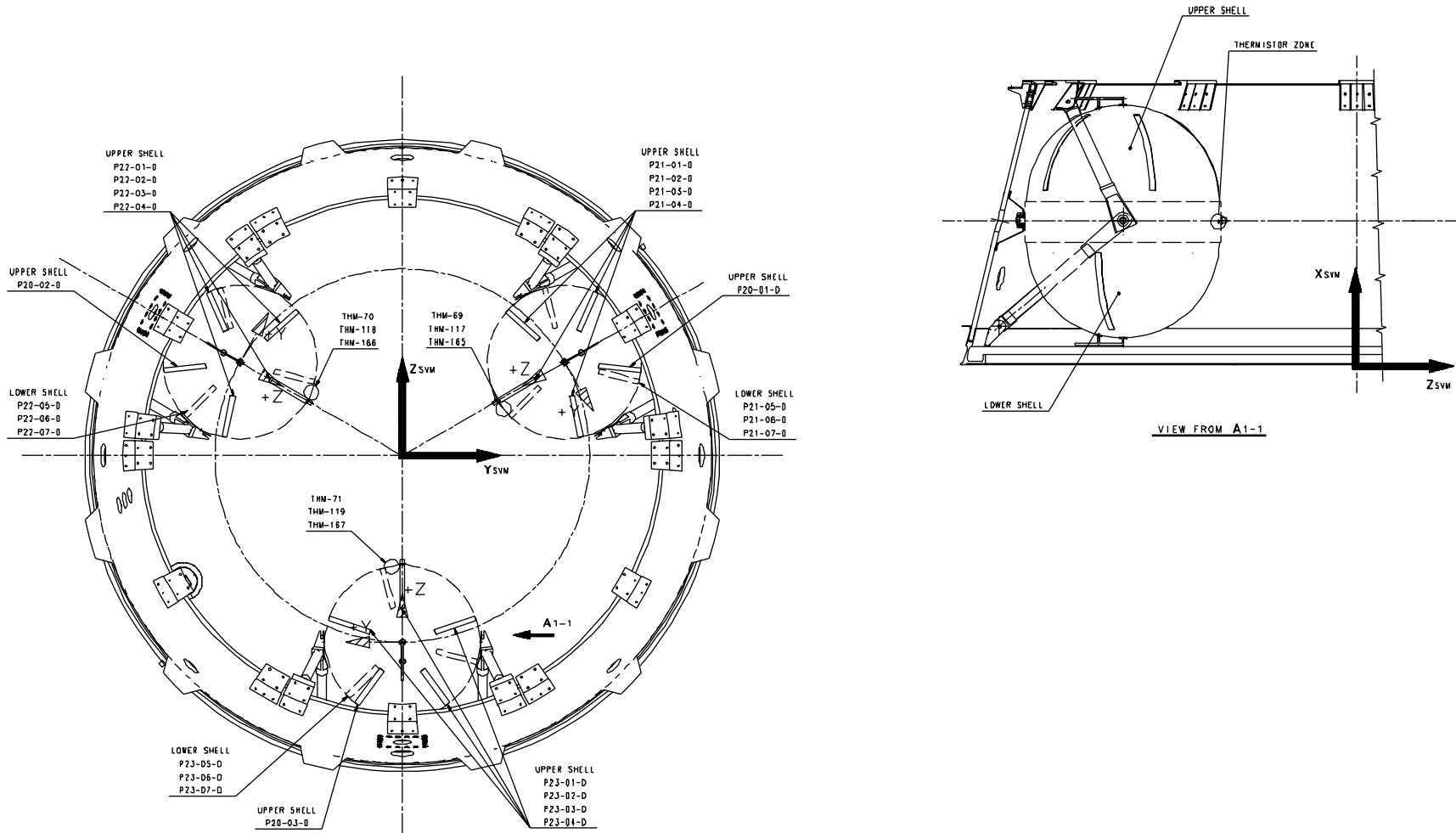

HERSCHEL PLANCK

Figure 3.1.2-6 PLANCK Upper Thruster (1N)

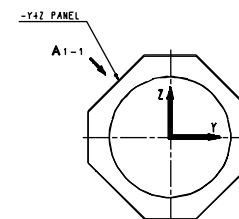
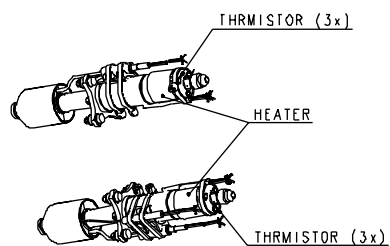

HERSCHEL PLANCK

DOC : H-P-TN-AI-0069

ISSUE : 05

DATE : 05/AUG/05

PAGE : 60 of 91

CLASS : DC

Figure 3.1.2-7a PLANCK Lower Thruster (20 N)

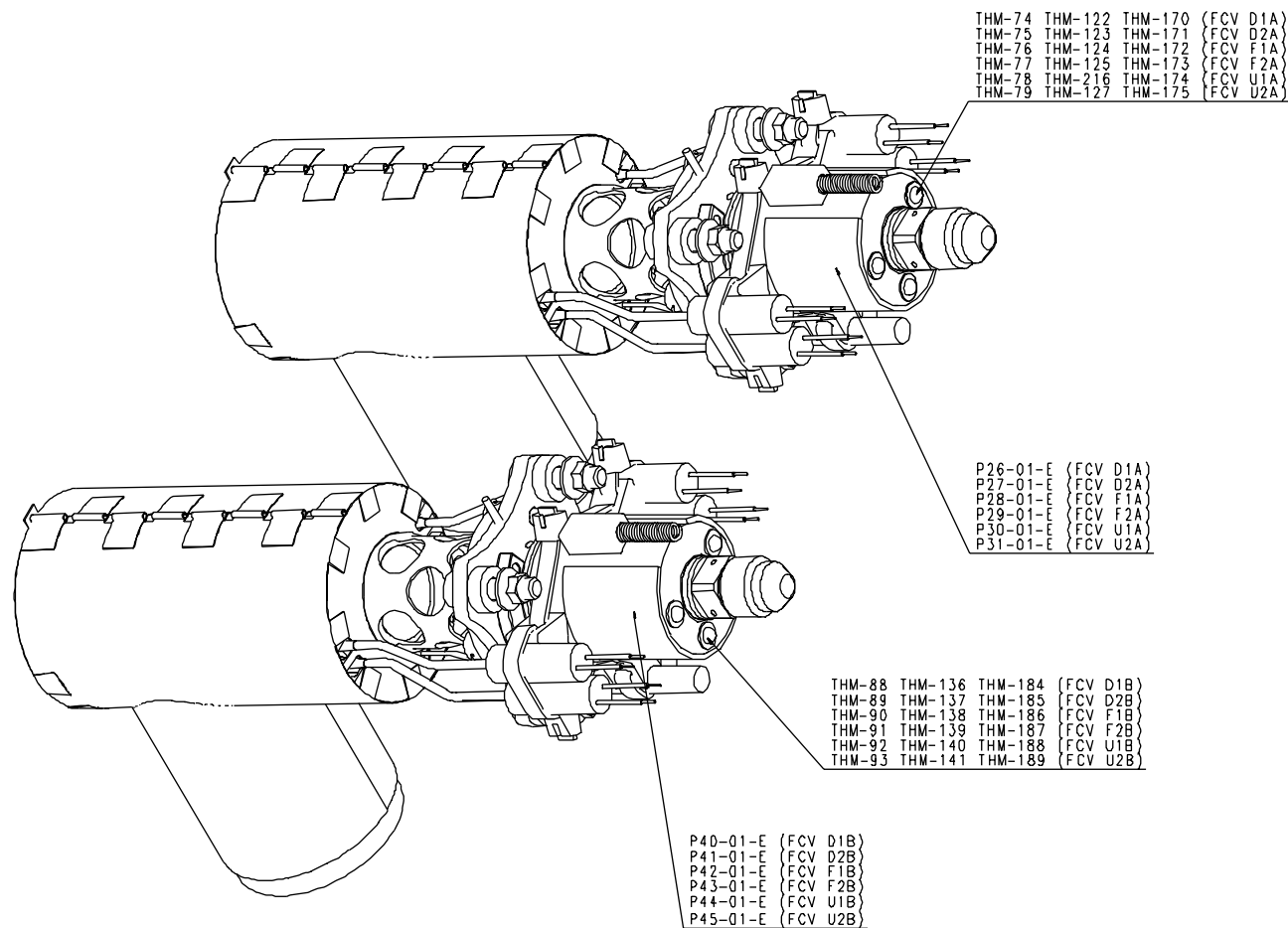

HERSCHEL PLANCK

Figure 3.1.2-7b PLANCK RCS unit heaters & thermistors

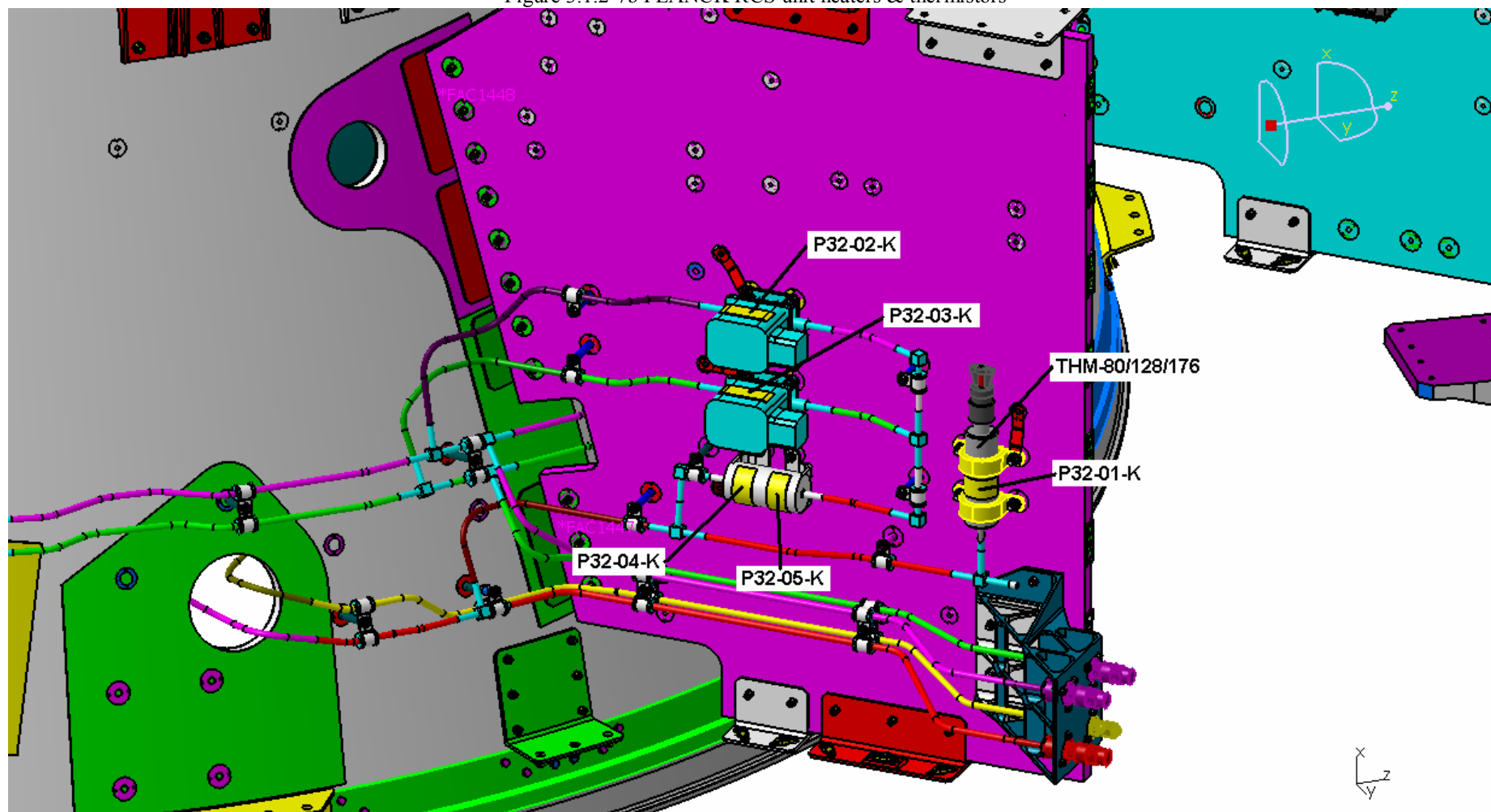

HERSCHEL PLANCK

Figure 3.1.2-8 PLANCK Heat Pipes

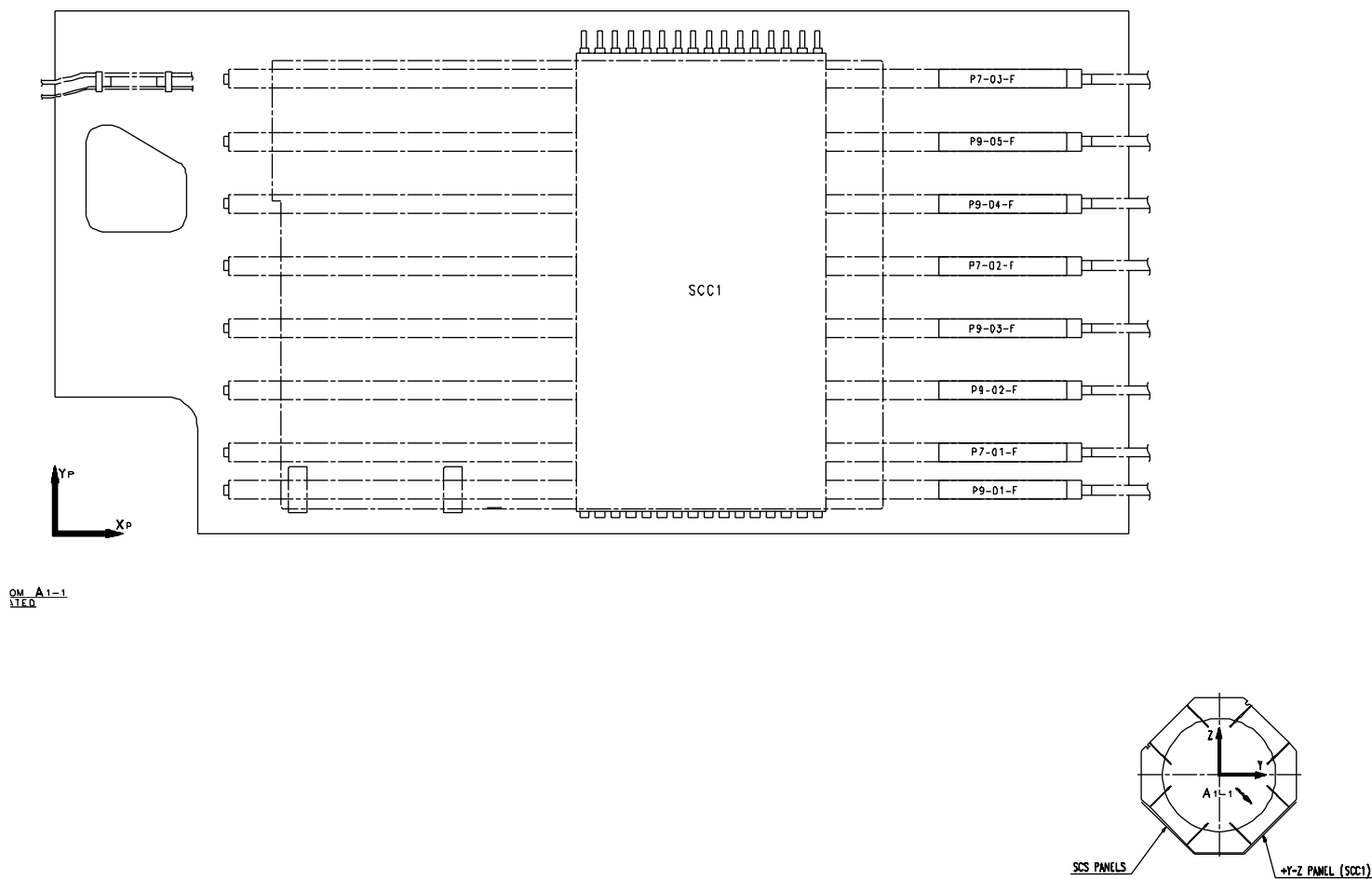

HERSCHEL PLANCK

Figure 3.1.2-9 PLANCK Heat Pipes

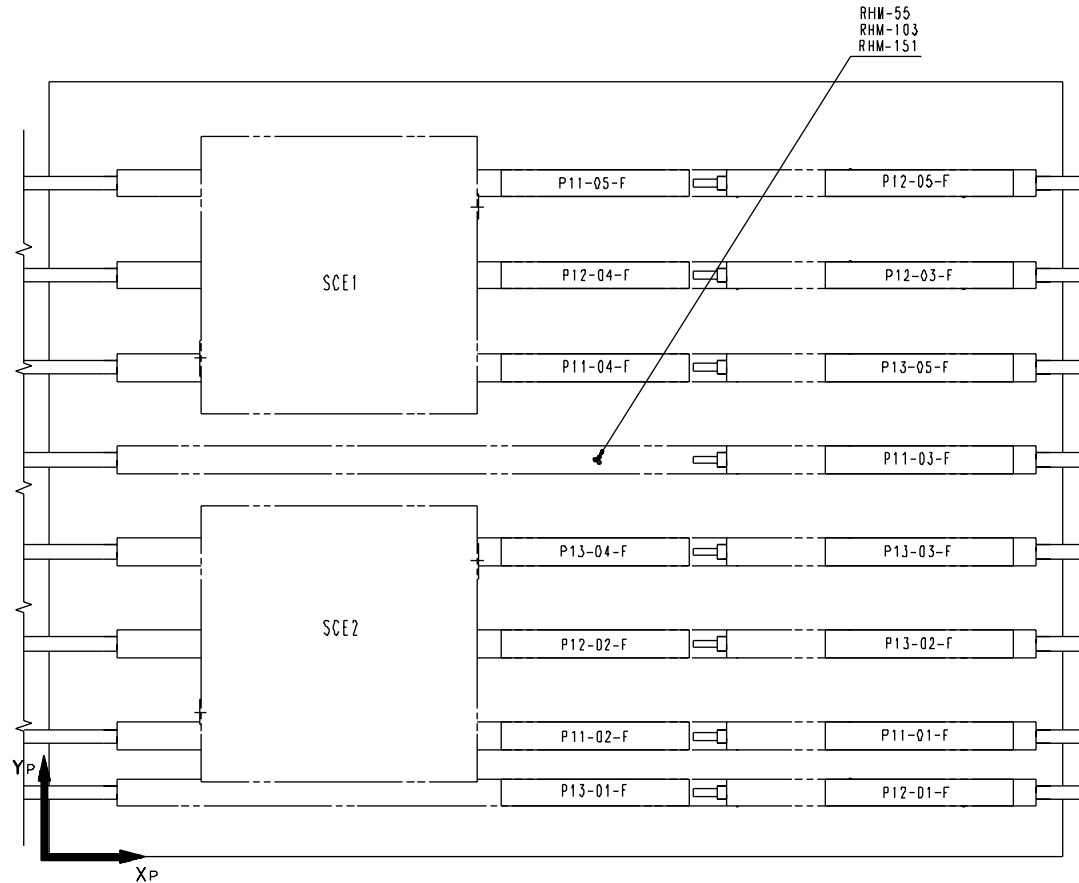

VIEW FROM A2-2
ROTATED OF 180°

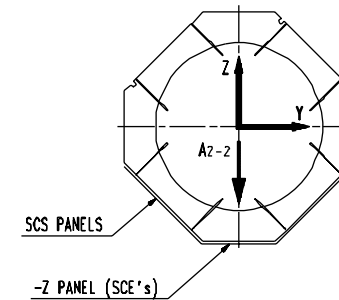

HERSCHEL PLANCK

Figure 3.1.2-10 PLANCK Heat Pipes

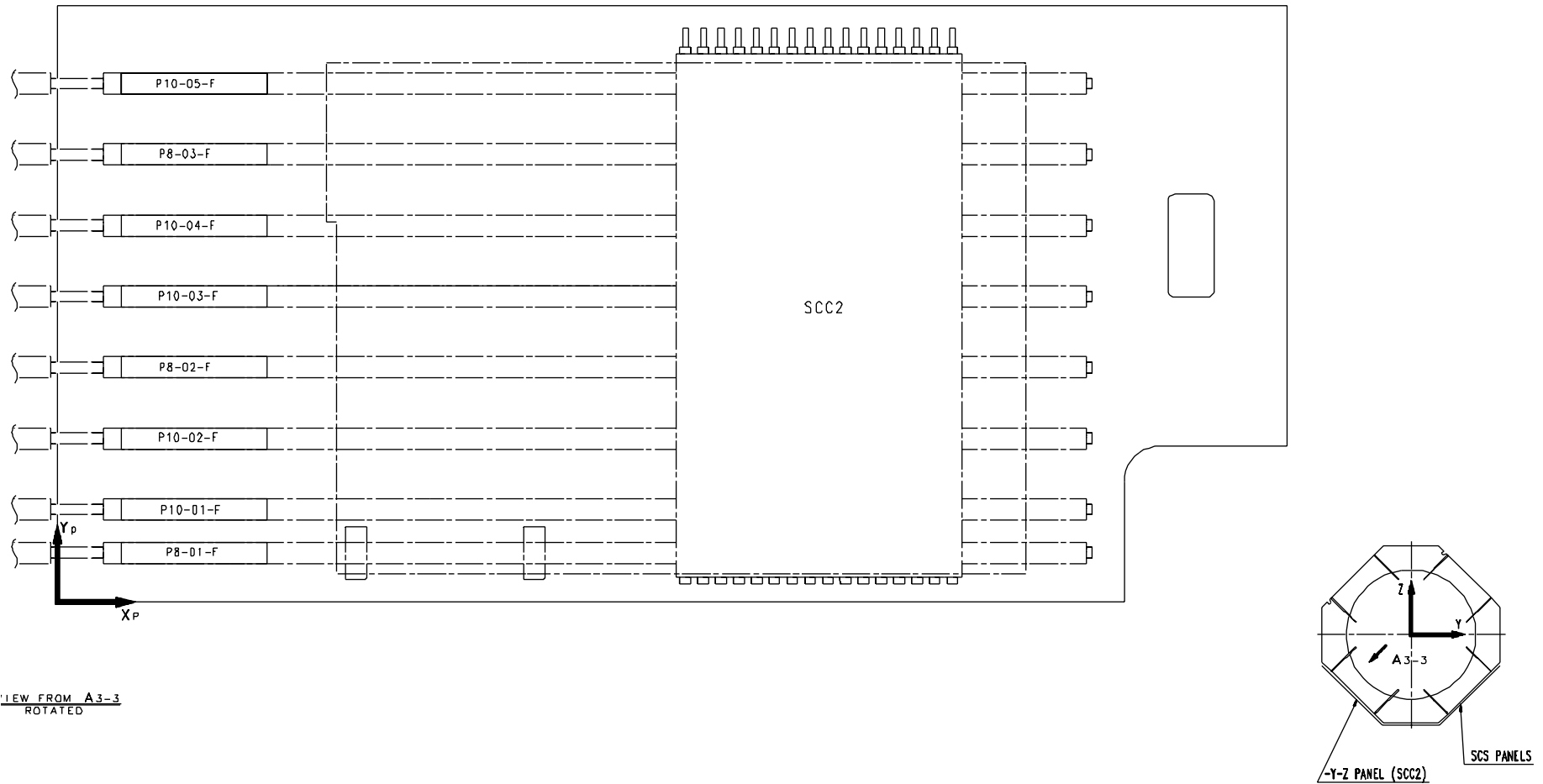

HERSCHEL PLANCK

DOC : H-P-TN-AI-0069

ISSUE : 05

DATE : 05/AUG/05

PAGE : 65 of 91

CLASS : DC

Figure 3.1.2-11 PLANCK SHEAR PANEL +Y+Z(+Z) 4CRU

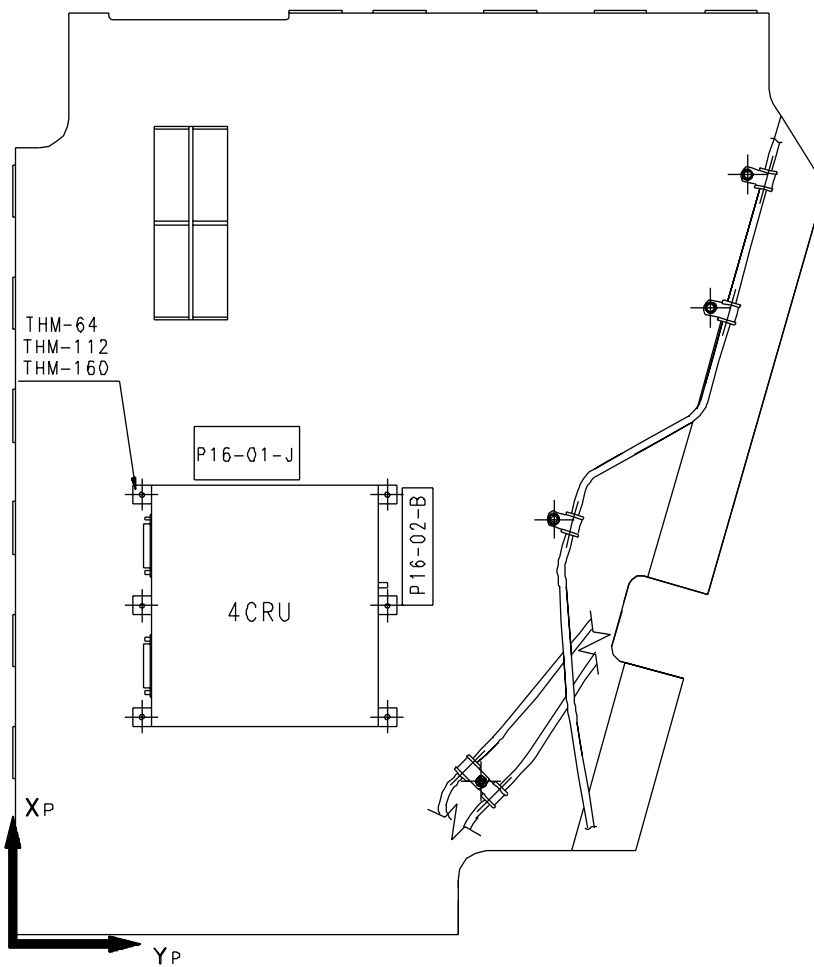

HERSCHEL PLANCK

Figure 3.1.2-12 PLANCK Subplatform PAU

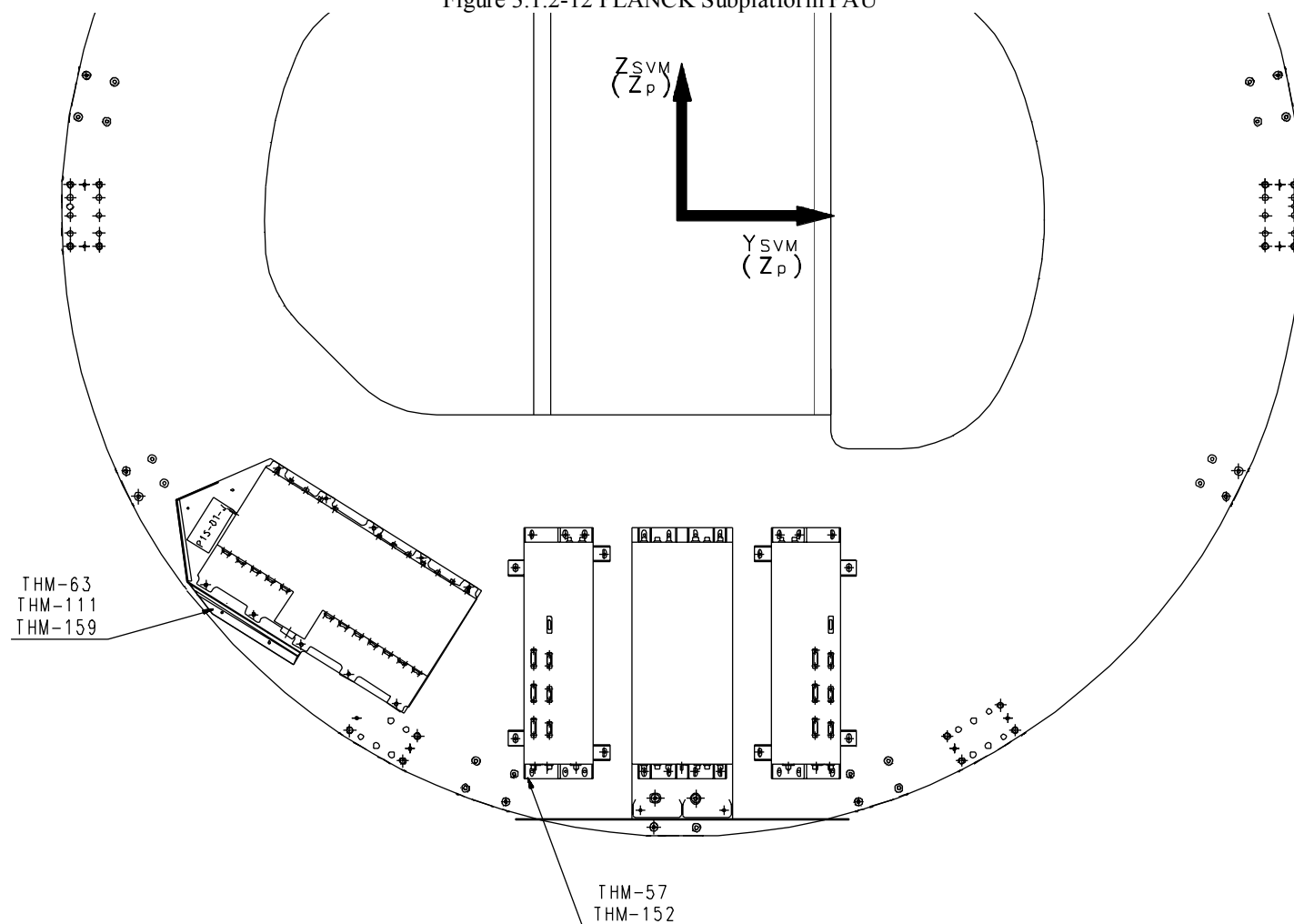

HERSCHEL PLANCK

Figure 3.1.2-13 PLANCK Subplatform DAE

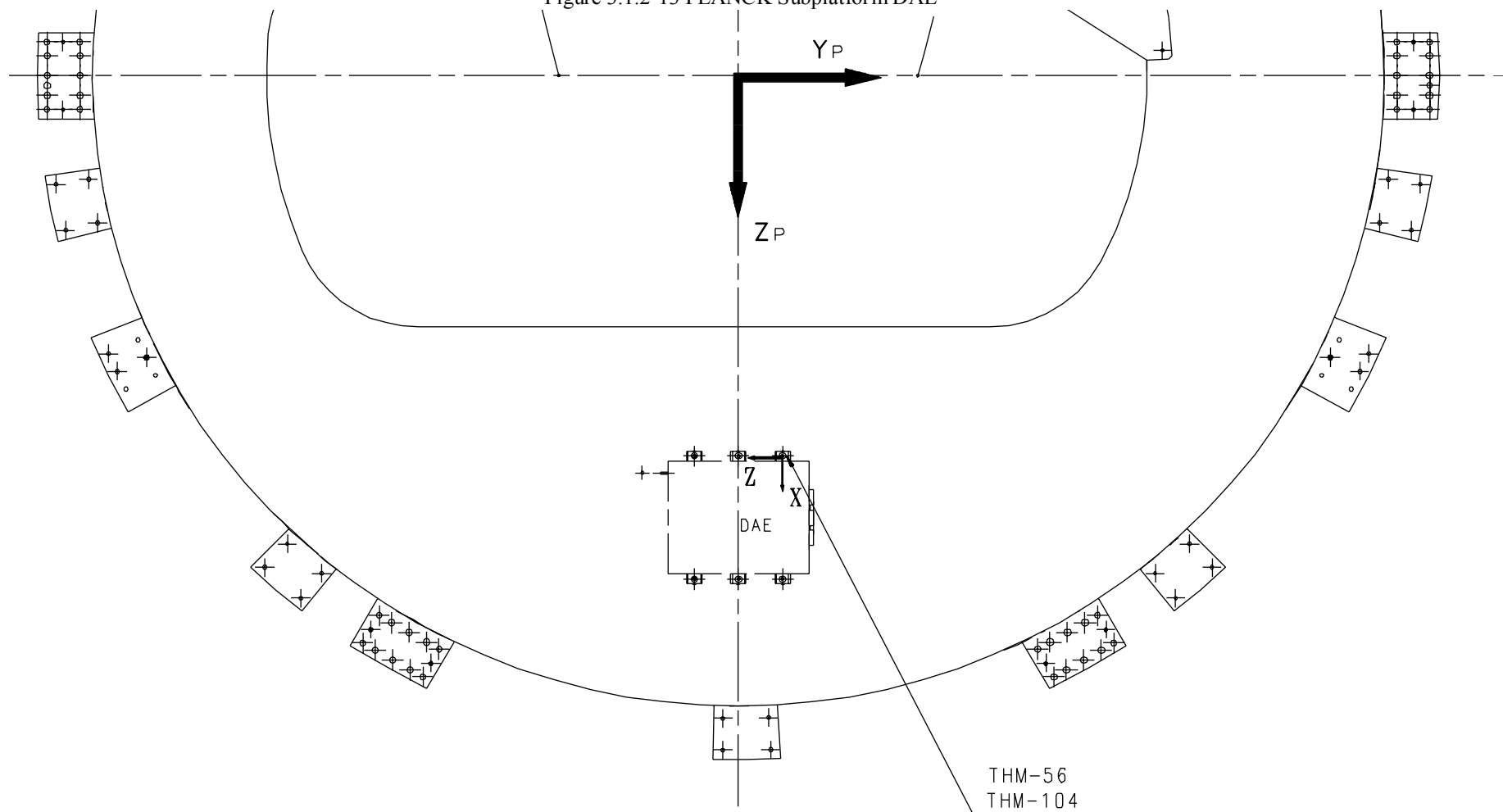

HERSCHEL PLANCK

Figure 3.1.2-14a PLANCK RCS

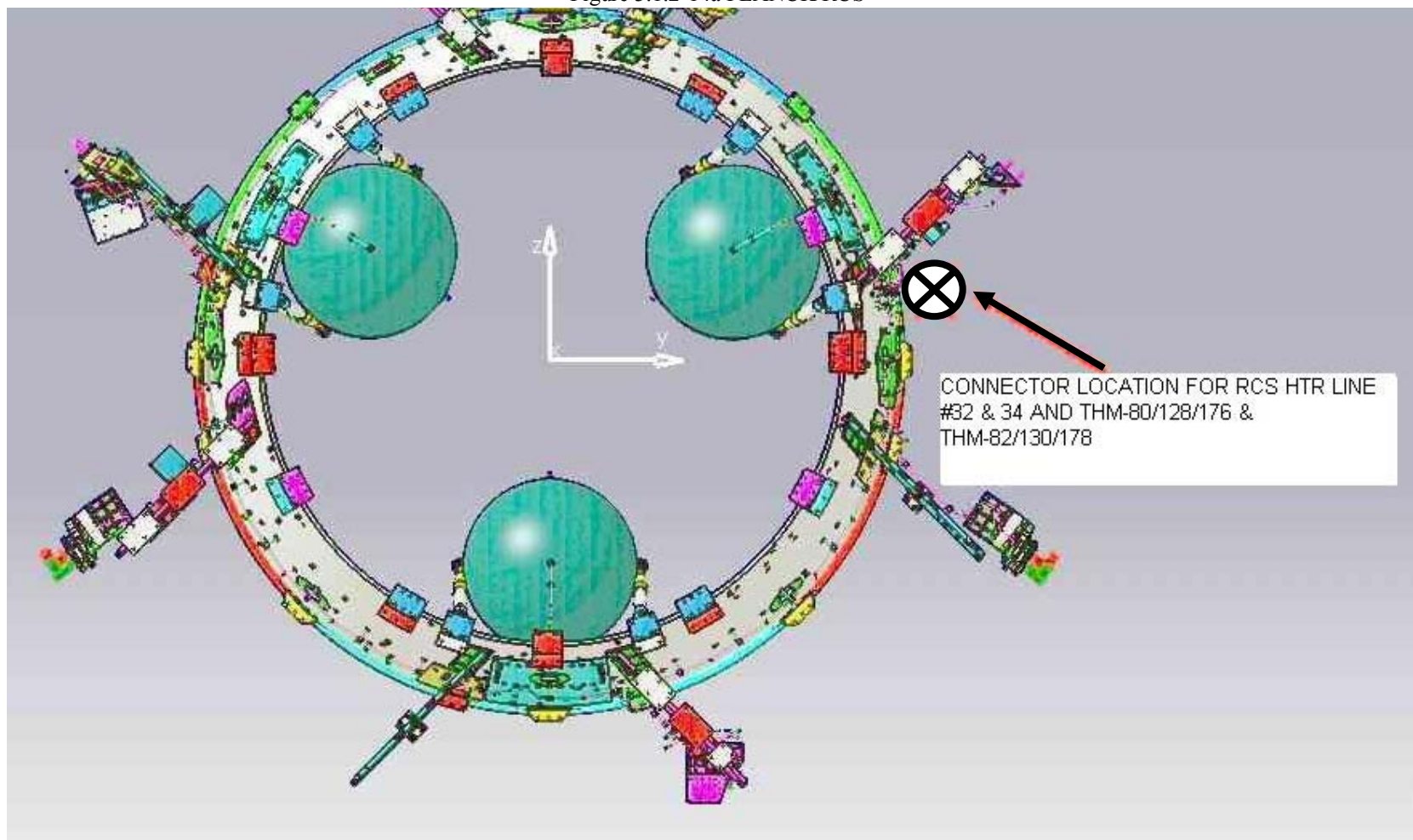

NOTE: FROM THE LOCATION OF THE CONNECTOR TO BE FORESEE 2 METERS EXTRA OF WIRES

HERSCHEL PLANCK

Figure 3.1.2-14b PLANCK RCS

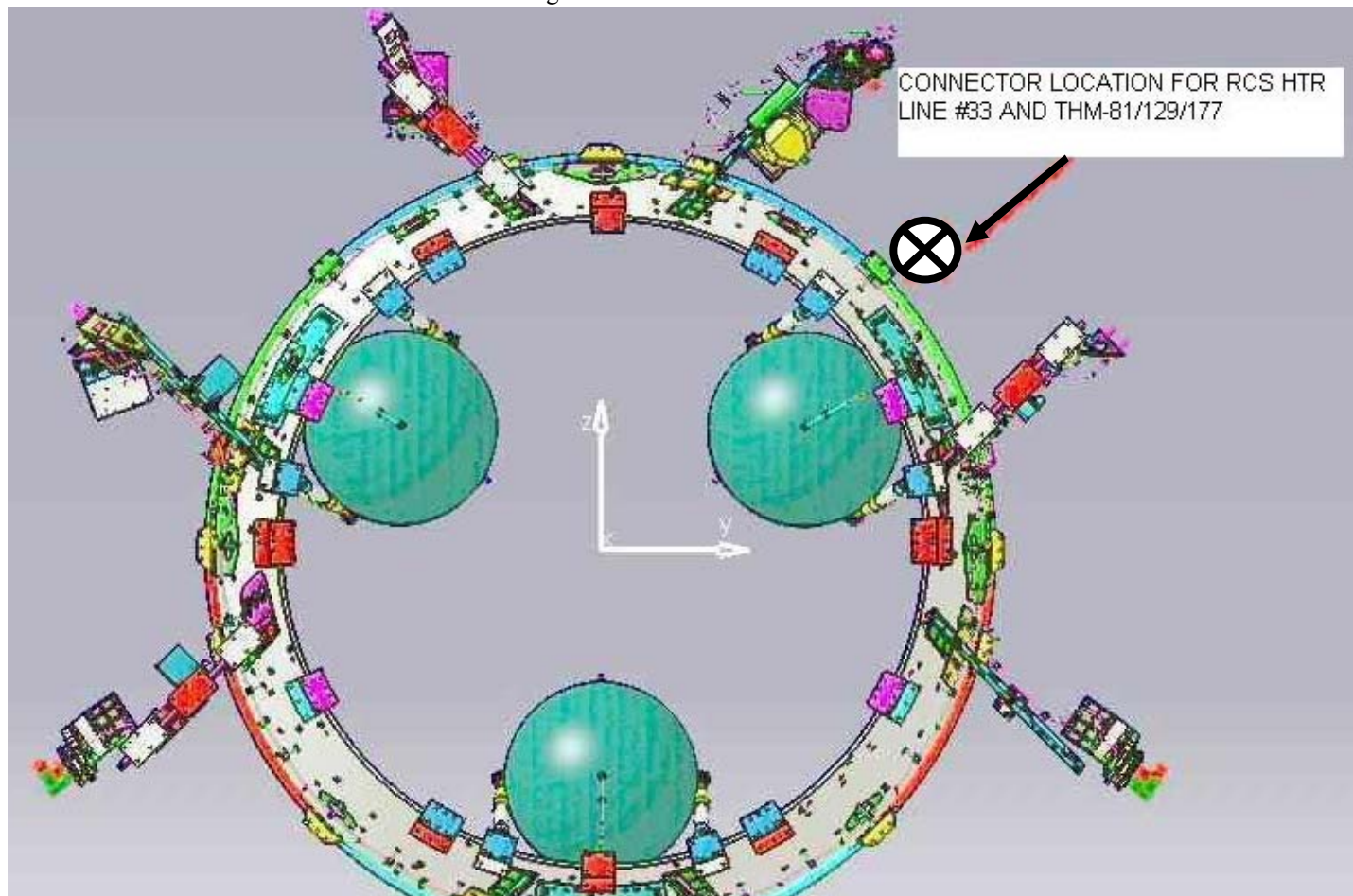

NOTE: FROM THE LOCATION OF THE CONNECTOR TO BE FORESEE 2 METERS EXTRA OF WIRES

HERSCHEL PLANCK

Figure 3.1.2-14c PLANCK RCS

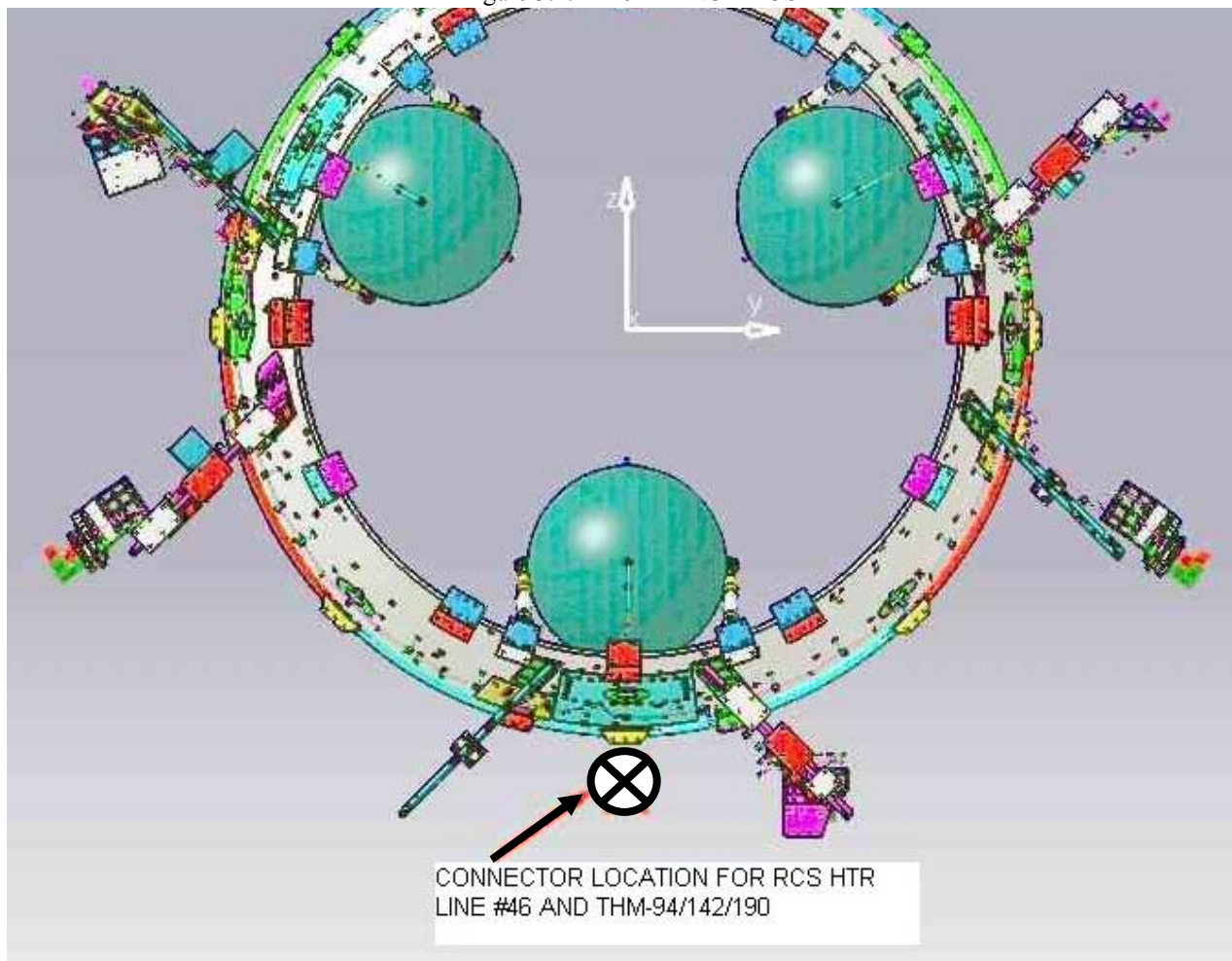

NOTE: FROM THE LOCATION OF THE CONNECTOR TO BE FORESEE 2 METERS EXTRA OF WIRES

HERSCHEL PLANCK

Figure 3.1.2-14d PLANCK RCS

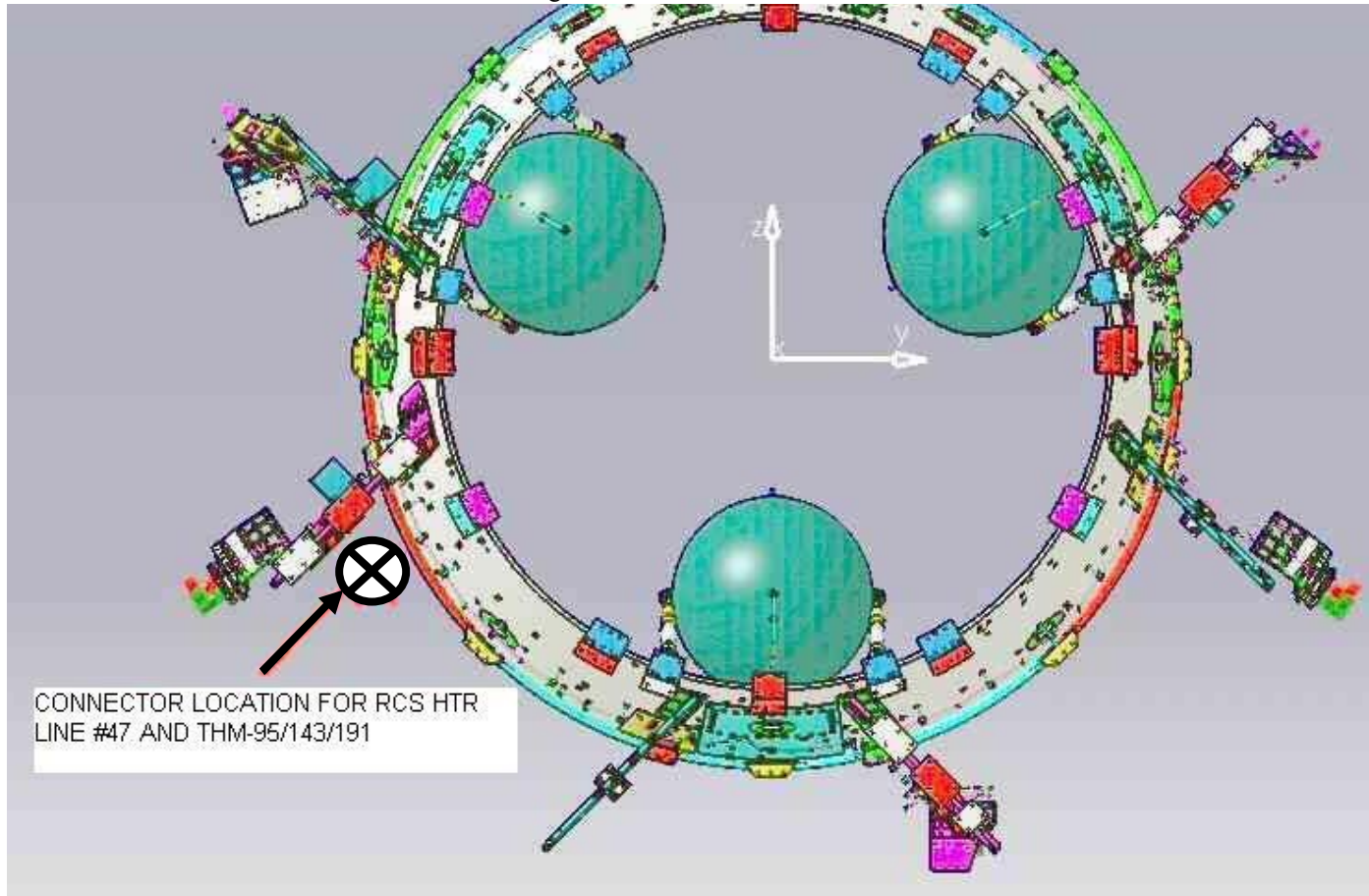

NOTE: FROM THE LOCATION OF THE CONNECTOR TO BE FORESEE 2 METERS EXTRA OF WIRES

HERSCHEL PLANCK

Figure 3.1.2-14e PLANCK RCS

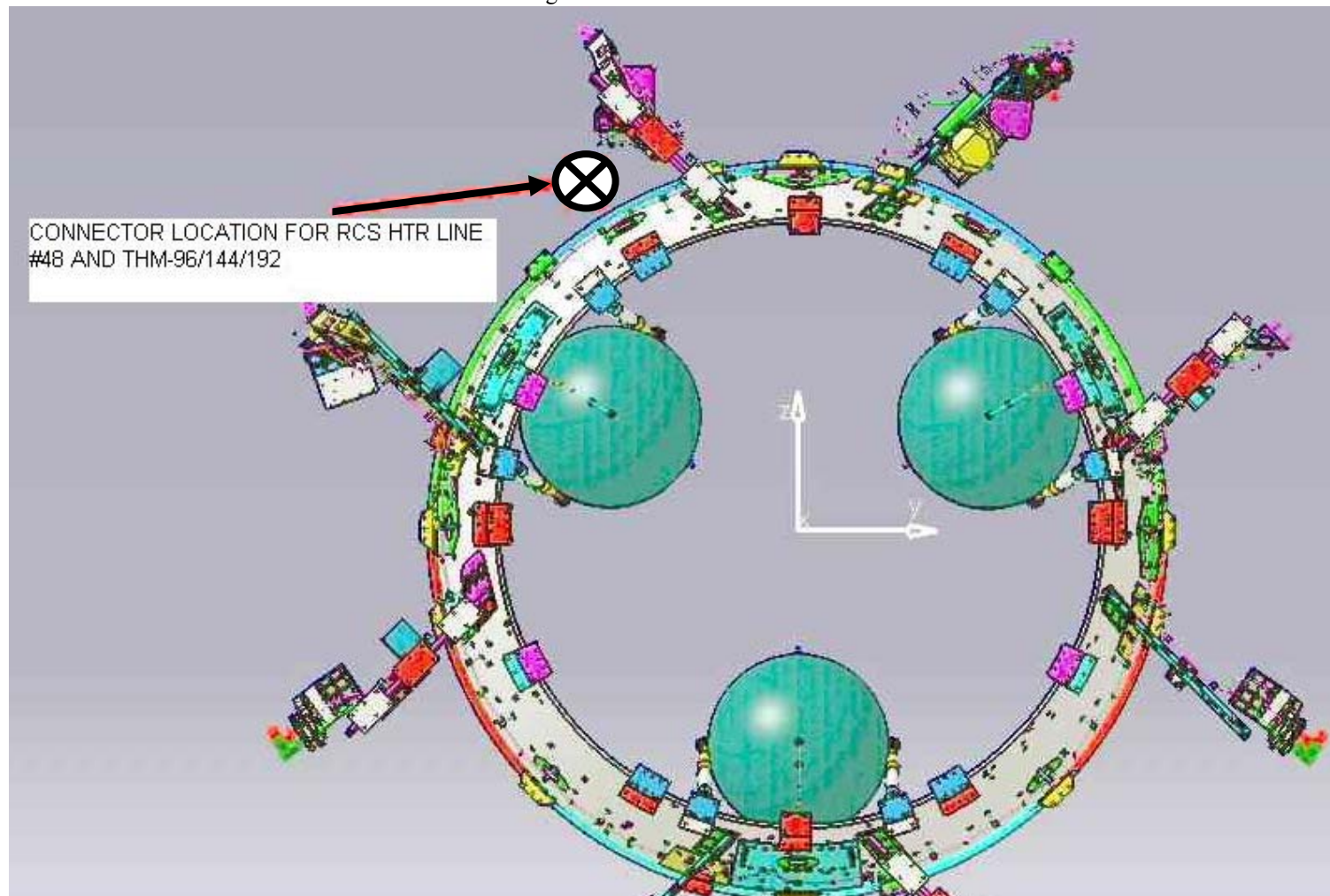

NOTE: FROM THE LOCATION OF THE CONNECTOR TO BE FORESEE 2 METERS EXTRA OF WIRES

HERSCHEL PLANCK

DOC : H-P-TN-AI-0069
ISSUE : 05
DATE : 05/AUG/05
PAGE : 73 of 91
CLASS : DC

Figure 3.1.2-15 PLANCK Helium Tanks

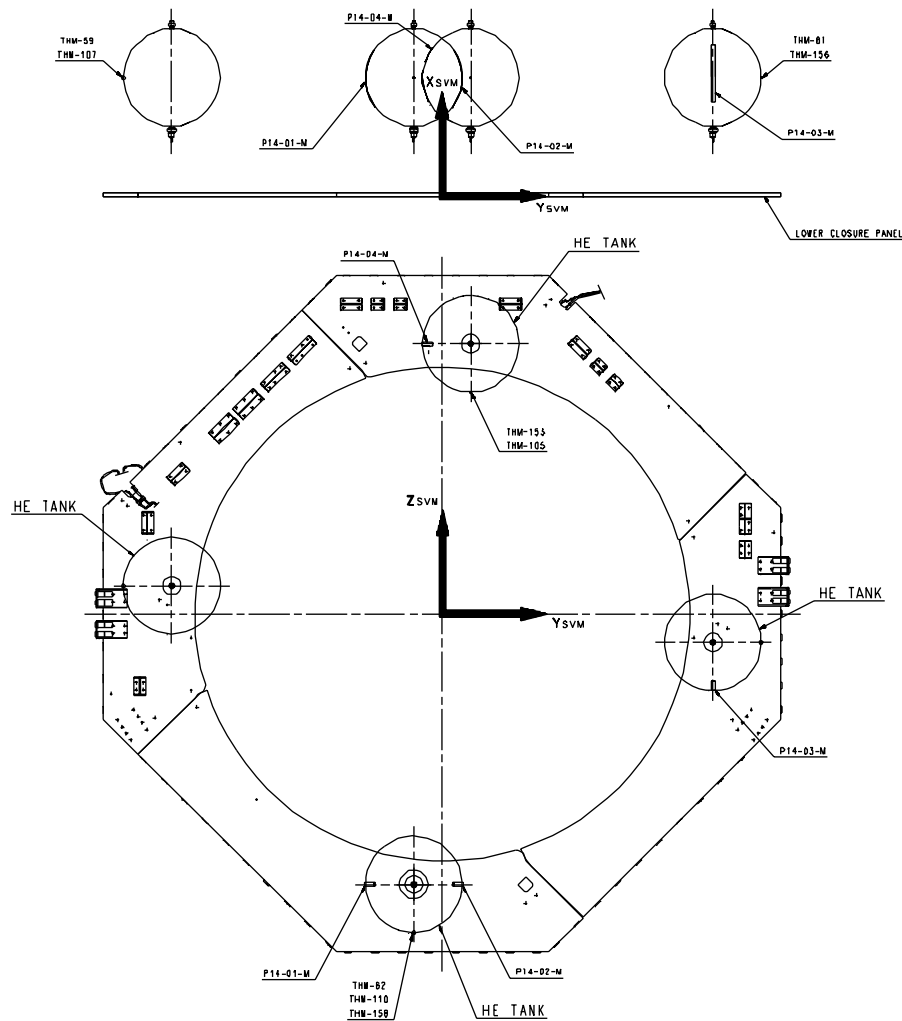

3.1.2.1 TCS line circuit description

PANEL +Z

Line 1: STAR TRACKER 1 = 4.7 W

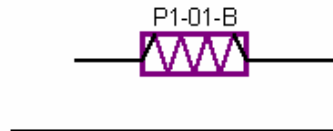

Line 2: STAR TRACKER 2 = 4.7 W

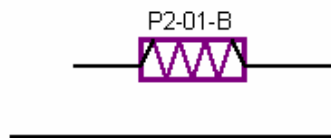

Line 3: DPU 1= 11.39 W + 11.39 W

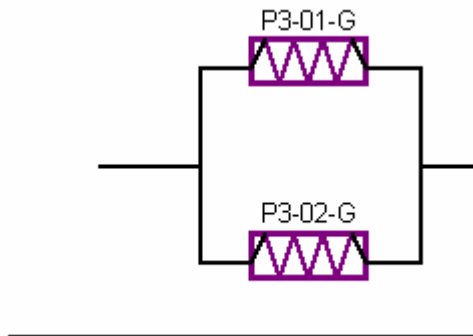

Line 4: DPU 2 = 11.39 W + 11.3

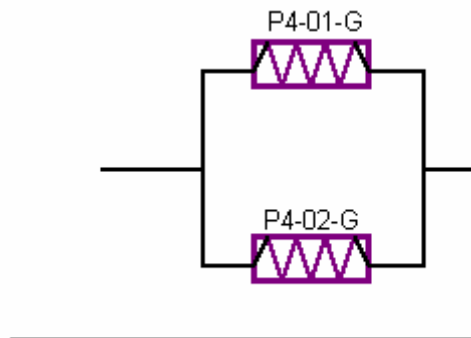

PANEL +Y

Line 5: REU = 15.51 W + 15.51 W + 15.51 W + 15.51 W

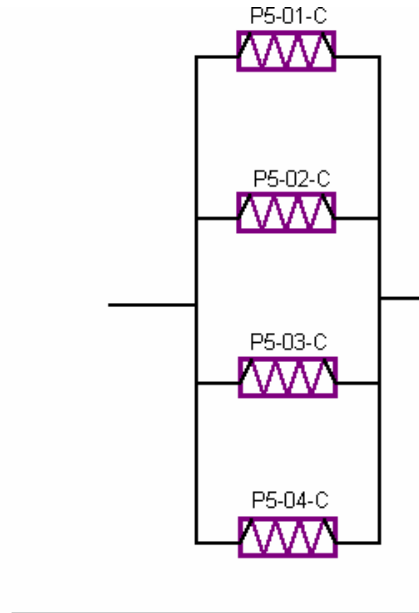

Line 6: CCU & CEU = 4.7 W + 4.7 W + 15.51 W + 8.1 W + 8.1 W + 11.39 W

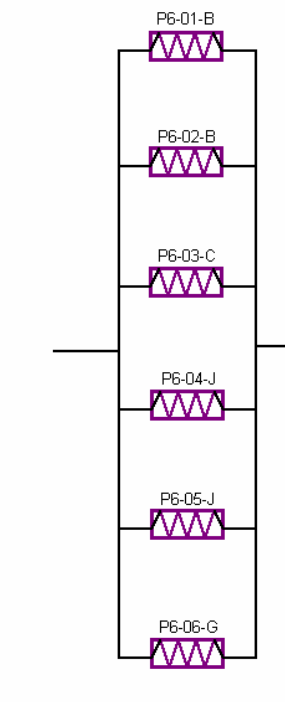

PANEL SCC

Line 7: HEAT PIPE SCE 1 = 26 W + 26 W + 26 W

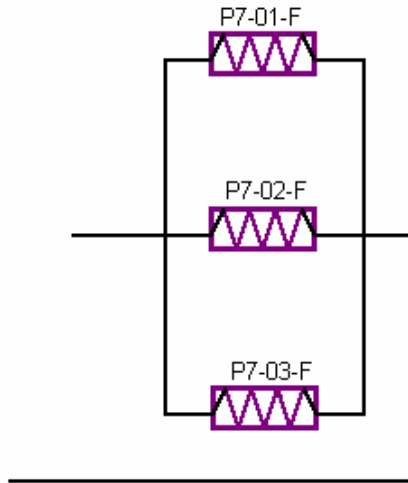

Line 8: HEAT PIPE SCE 1 = 26 W + 26 W W + 26 W

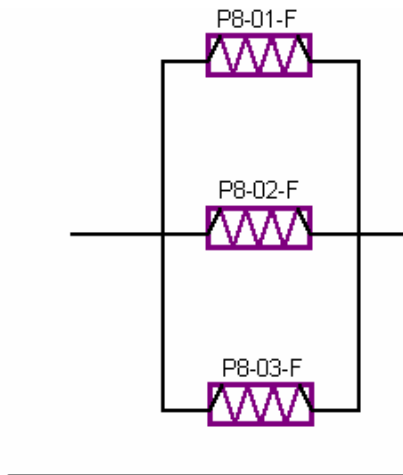

Line 9: HEAT PIPE SCE 2 = 26 W + 26 W + 26 W + (6.5 W + 6.5 W)

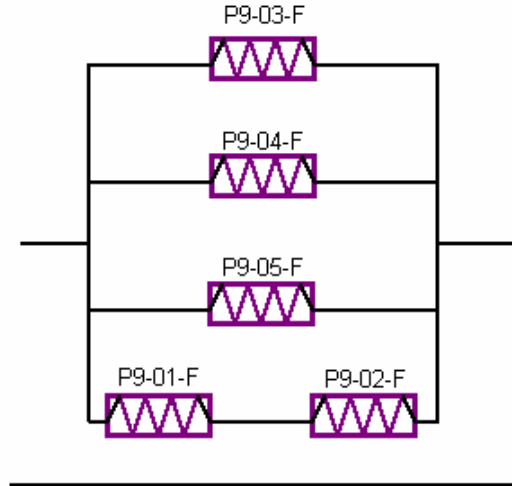

Line 10: HEAT PIPE SCE 2 = 26 W + 26 W W + 26 W + (6.5 W + 6.5 W)

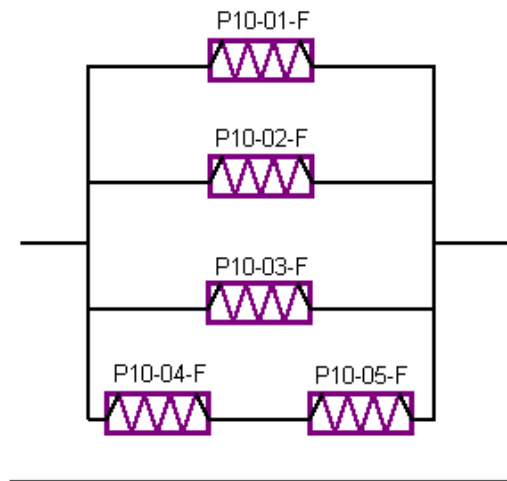

HERSCHEL PLANCK

Line 11: HEAT PIPE SCE 1 = 26 W + 26 W + 26 W + (6.5 W + 6.5 W)

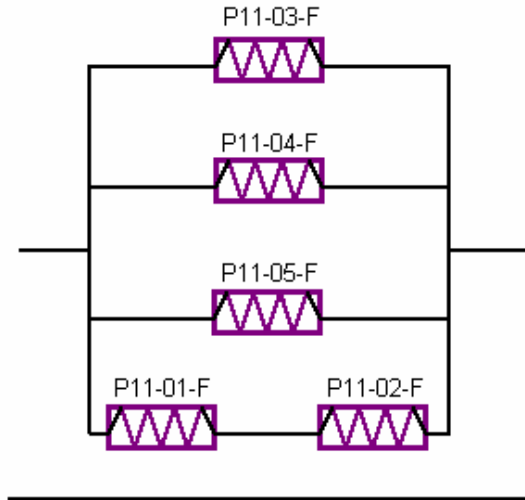

Line 12: HEAT PIPE SCE 1 = 26 W + 26 W + 26 W + (6.5 W + 6.5 W)

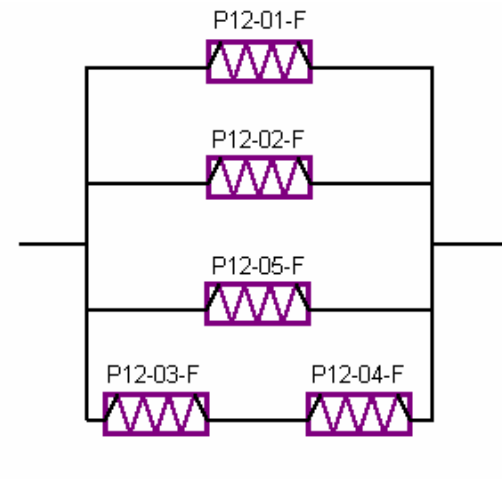

Line 13: HEAT PIPE SCE 2 = 26 W + 26 W + 26 W + (6.5 W + 6.5 W)

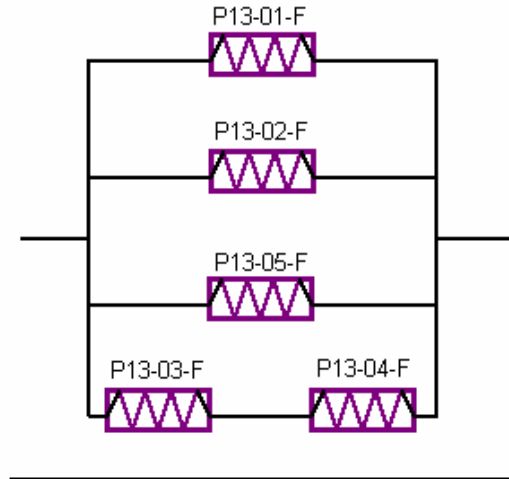

Line 14: He TANK's = 0.77 W + 0.77 W + 0.77 W + 0.77 W

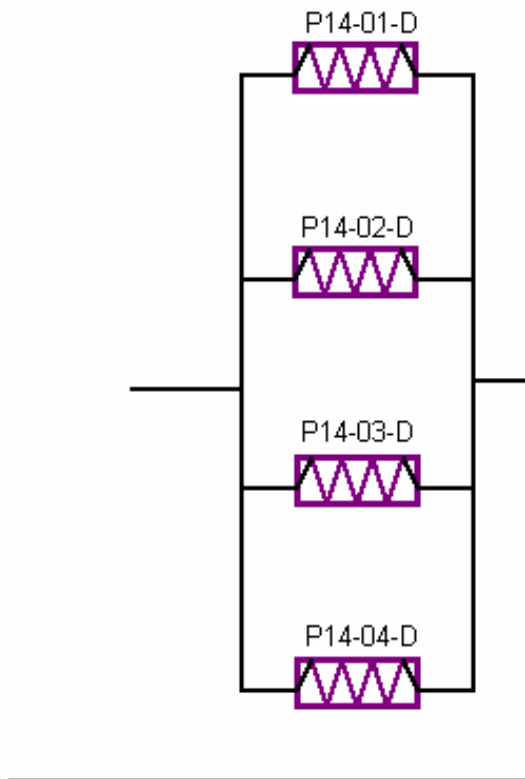

SUBPLATFORM

Line 15: PAU = 8.1 W

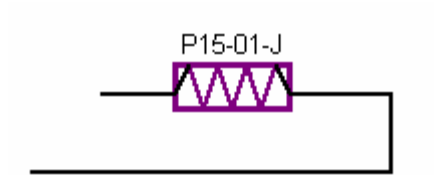

SHEAR PANEL +Z+Y

Line 16: 4CRU = 8.1 W + 4.7 W

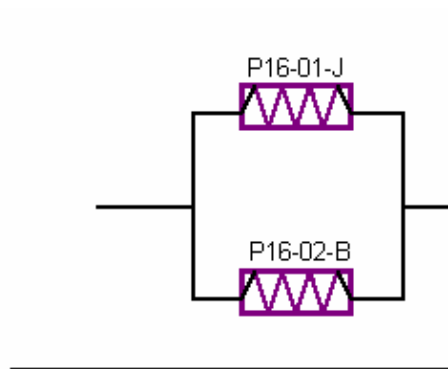

TANK's

Line 20: TANK +Z-Y/+Z-Y/-Z = 0.77 W + 0.77 W + 0.77 W = **2.31 W**

REMARKS:

These Heater connections must be performed outside of the TANK MLI blankets

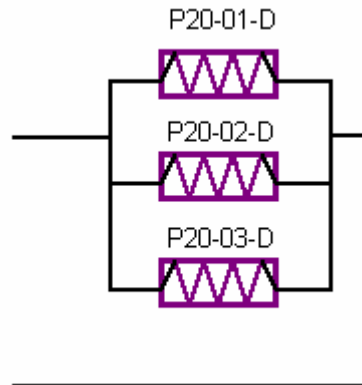

Line 21: TANK +Z+Y = 0.77 W + 0.77 W + 0.77 W + 0.77 W + 0.77 W + 0.77 W + 0.77 W = **5.4 W**

REMARKS:

These Heater connections must be performed outside of the TANK MLI blankets

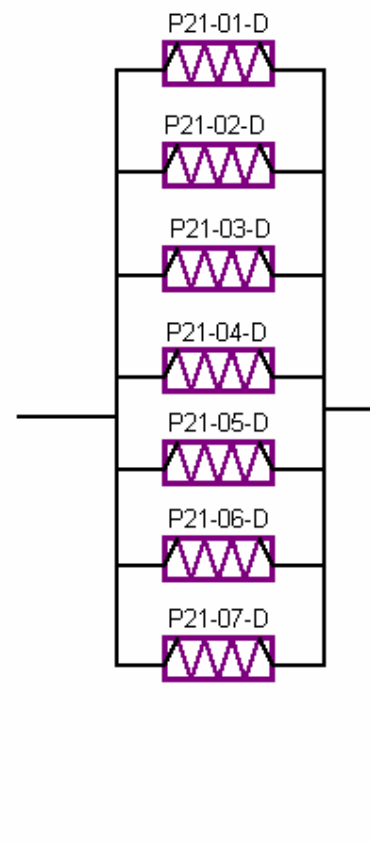

HERSCHEL PLANCK

Line 22: TANK +Z-Y = 0.77 W + 0.77 W + 0.77 W + 0.77 W + 0.77 W + 0.77 W + 0.77 W = 5.4 W

REMARKS:

These Heater connections must be performed outside of the TANK MLI blankets

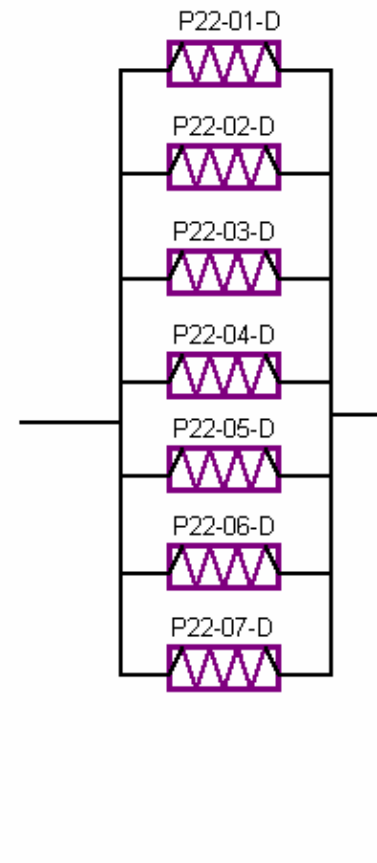

Line 23: TANK -Z = 0.77 W + 0.77 W + 0.77 W + 0.77 W + 0.77 W + 0.77 W + 0.77 W = 5.4 W

REMARKS:

These Heater connections must be performed outside of the TANK MLI blankets

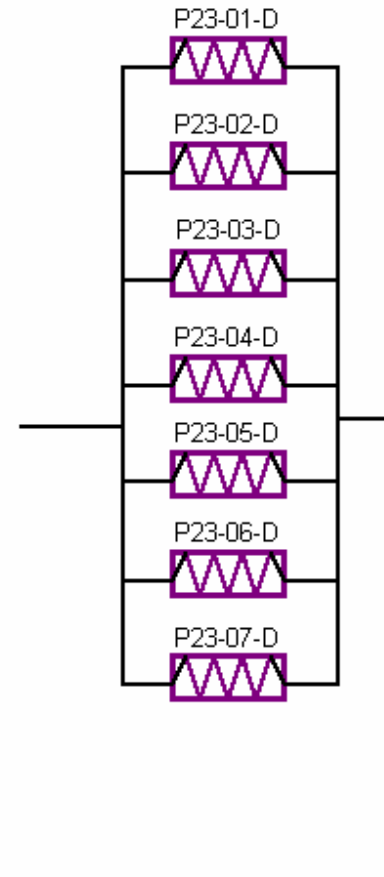

THRUSTER FCV-A

Line 24: 1N FCV A1A on $-Y+Z$ (+Z side) = 2.35 W

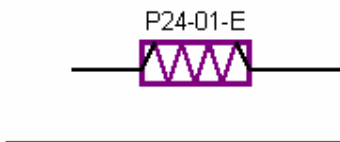

Line 25: 1N FCV B1A on $-Y+Z$ (-Z side) = 2.35 W

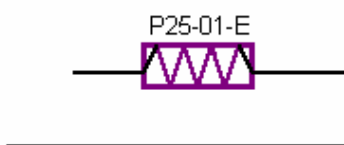

Line 26: 20N FCV D1A = 1.43 W

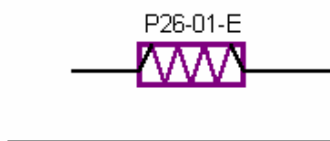

Line 27: 20N FCV D2A = 1.43 W

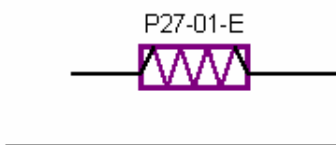

Line 28: 20N FCV F1A = 1.43 W

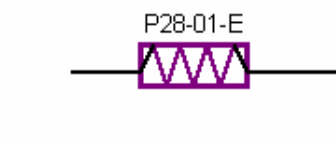

Line 29: 20N FCV F2A = 1.43 W

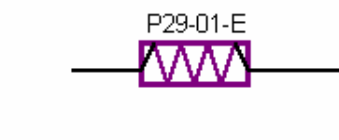

Line 30: 20N FCV U1A = 1.43 W

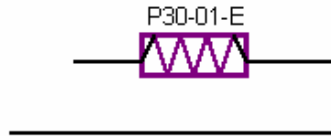

Line 31: 20N FCV U2A = 1.43 W

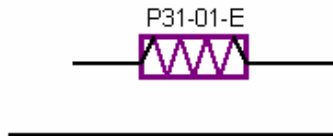

RCS UNITS

Line 32: RCS Units = 1.4 W + 1.4 W + 1.4 W + (0.35 W + 0.35 W)

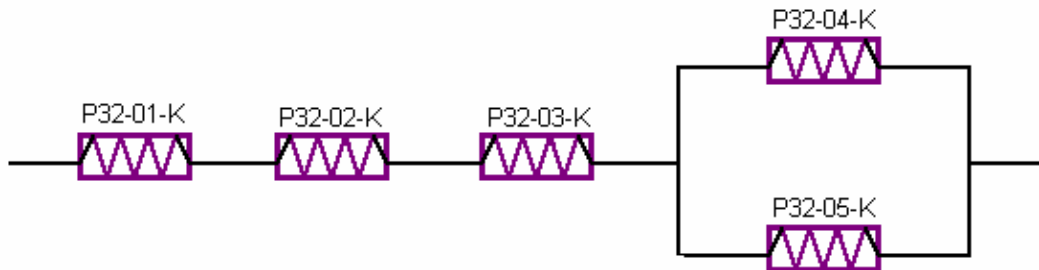

REMARKS:

Heater P32-01-K must be connected to positive voltage (+27V).

PANEL +Y

Line 35: CAU = 8.1 W + 8.1 W + 11.39 W + 11.39 W

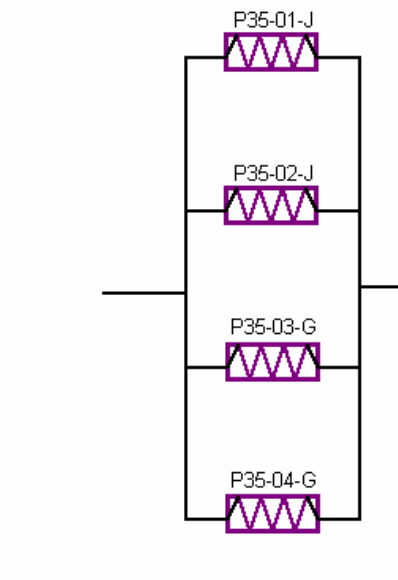

PANEL +Z+Y

Line 36: REBA 1 & 2 = 11.39 W + 11.39 W

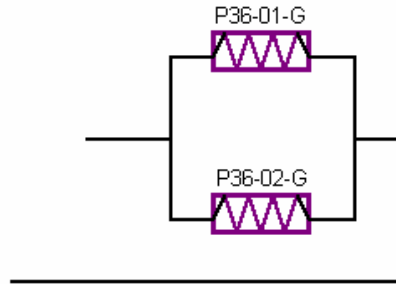

THRUSTER FCV-B

Line 38: 1N FCV B on -Y+Z (+Z side) = 2.35 W

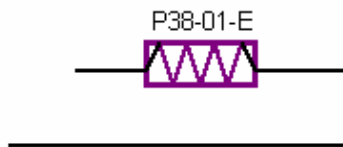

Line 39: 1N FCV B on -Y+Z (-Z side) = 2.35 W

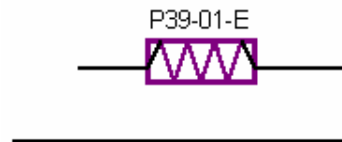

Line 40: 20N FCV D1B = 1.43 W

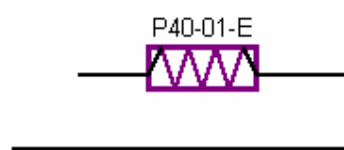

Line 41: 20N FCV D2B = 1.43 W

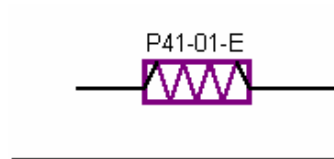

Line 42: 20N FCV F1B= 1.43 W

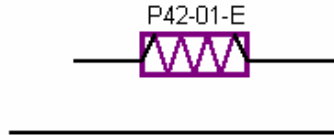

Line 43: 20N FCV F2B= 1.43 W



Line 44: 20N FCV U1B= 1.43 W



Line 45: 20N FCV U2B= 1.43 W

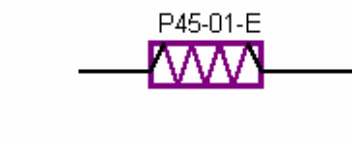

HERSCHEL PLANCK

4. THERMISTORS

The list of thermistors is shown in table 4-1 for HERSCHEL and 4-2 for PLANCK. The main characteristics of the thermistors are reported in RD3.

N.B. The thermistors are installed on the baseplate of the unit.

4.1 HERSCHEL THERMISTORS LIST

HERSCHEL	HEATER's location	Heater line status Used/spare Not-available	Unit ON	Unit OFF or	MODULE = SIOH1			MODULE = SIOH2			MODULE = SIOH3			Group
			Threshold	Survival	Th. Location		M/C	Th. Location		M/C	Th. Location		M/C	
Heater line			[°C]	[°C]										
TCS Line 01	close to XPND1	used	-9/-6	-19/-16	XPND1	THM-49	M+C	XPND1	THM-97	M+C	XPND1	THM-145	M+C	ET0
TCS Line 02	close to XPND2	used	-9/-6	-19/-16	XPND2	THM-50	M+C	XPND2	THM-98	M+C	XPND2	THM-146	M+C	ET0
TCS Line 03	inside BATTERY	used	1/4	1/4	BATTERY	THM-51	M+C	BATTERY	THM-99	M+C	BATTERY	THM-147	M+C	ET0
TCS Line 04	N/A	not-available	N/A	N/A	FPDPU	THM-52	M	FPDPU	THM-100	M		THM-148	spare	ET0
TCS Line 05	close to FPSPU, FPDPU	used	N/A	-29/-26	FPSPU	THM-53	M+C	FPSPU	THM-101	M+C	FPSPU	THM-149	M+C	ET0
TCS Line 06	close to FPBOLC	used	-14/-11	-29/-26	FPBOLC	THM-54	M+C	FPBOLC	THM-102	M+C	FPBOLC	THM-150	M+C	ET0
TCS Line 07		spare				THM-55			THM-103	spare		THM-151	spare	ET0
TCS Line 08	close to FPDECMC	used	-14/-11	-29/-26	FPDECMC	THM-56	M+C	FPDECMC	THM-104	M+C	FPDECMC	THM-152	M+C	ET0
TCS Line 09	RCS PIPES	used	31/32	36/37	RCS piping	THM-57	M+C	RCS piping	THM-105	M+C	RCS piping	THM-153	M+C	ET0
TCS Line 10	close to CCU, HSDCU, HSFCU	used	-9/-6	-19/-16	CCU	THM-58	M+C	CCU	THM-106	M+C	CCU	THM-154	M+C	ET0
TCS Line 11	RCS PIPES	used	27/28	27/28	RCS piping	THM-59	M+C	RCS piping	THM-107	M+C	RCS piping	THM-155	M+C	ET0
TCS Line 12	close to FHWOV	used	C.L.	-24/-21	FHWOV	THM-60	M+C	FHWOV	THM-108	M+C	FHWOV	THM-156	M+C	ET0
TCS Line 13	close to FHHRV	used	-9/-6	-24/-21	FHHRV	THM-61	M+C	FHHRV	THM-109	M+C	FHHRV	THM-157	M+C	ET0
TCS Line 14	close to FHFCU	used	-9/-6	-24/-21	FHFCU	THM-62	M+C	FHFCU	THM-110	M+C	FHFCU	THM-158	M+C	ET0
TCS Line 15	close to FHWEV, FHICU	used	1/4	-24/-21	FHWEV	THM-63	M+C	FHWEV	THM-111	M+C	FHWEV	THM-159	M+C	ET0
TCS Line 16	close to FHWOH	used	C.L.	-24/-21	FHWOH	THM-64	M+C	FHWOH	THM-112	M+C	FHWOH	THM-160	M+C	ET0
TCS Line 17	close to FHWEH	used	1/4	-24/-21	FHWEH	THM-65	M+C	FHWEH	THM-113	M+C	FHWEH	THM-161	M+C	ET1
TCS Line 18	close to FHHRH	used	-9/-6	-24/-21	FHHRH	THM-66	M+C	FHHRH	THM-114	M+C	FHHRH	THM-162	M+C	ET1
TCS Line 19	close to FHLCU, FHIFH	used	-9/-6	-24/-21	FHLCU	THM-67	M+C	FHLCU	THM-115	M+C	FHLCU	THM-163	M+C	ET1
TCS Line 20	close to FHLSU	used	11/14	-24/-21	FHLSU	THM-68	M+C	FHLSU	THM-116	M+C	FHLSU	THM-164	M+C	ET1
TCS Line 21	on RWL2	used	1/4	1/4	RWL2 cover	THM-69	M+C	RWL2 cover	THM-117	M+C	RWL2 cover	THM-165	M+C	ET1
TCS Line 22	on RWL4	used	1/4	1/4	RWL4 cover	THM-70	M+C	RWL4 cover	THM-118	M+C	RWL4 cover	THM-166	M+C	ET1
TCS Line 23	on RWL1	used	1/4	1/4	RWL1 cover	THM-71	M+C	RWL1 cover	THM-119	M+C	RWL1 cover	THM-167	M+C	ET1
TCS Line 24	on RWL3	used	1/4	1/4	RWL3 cover	THM-72	M+C	RWL3 cover	THM-120	M+C	RWL3 cover	THM-168	M+C	ET1
TCS Line 25	on TANK +Y	used	11/14	11/14	TANK +Y	THM-73	M+C	TANK +Y	THM-121	M+C	TANK +Y	THM-169	M+C	ET1
TCS Line 26	on TANK -Y	used	11/14	11/14	TANK -Y	THM-74	M+C	TANK -Y	THM-122	M+C	TANK -Y	THM-170	M+C	ET1
TCS Line 27	close to STR's	used	C.L.	-29/-26	STR center plate	THM-75	M+C	STR center plate	THM-123	M+C	STR center plate	THM-171	M+C	ET1
TCS Line 28	close to FHIFV	used	C. L.	-24/-21	FHIFV	THM-76	M+C	FHIFV	THM-124	M+C	FHIFV	THM-172	M+C	ET1
TCS Line 29	on FCV A1A	used	11/14	11/14	FCV A1A	THM-77	M+C	FCV A1A	THM-125	M+C	FCV A1A	THM-173	M+C	ET1
TCS Line 30	on FCV C2A	used	11/14	11/14	FCV C2A	THM-78	M+C	FCV C2A	THM-126	M+C	FCV C2A	THM-174	M+C	ET1
TCS Line 31	on FCV C1A	used	11/14	11/14	FCV C1A	THM-79	M+C	FCV C1A	THM-127	M+C	FCV C1A	THM-175	M+C	ET1

HERSCHEL PLANCK

HERSCHEL	HEATER's location	Heater line status Used/spare Not-available	Unit ON	Unit OFF or	MODULE = SIOH1			MODULE = SIOH2			MODULE = SIOH3			Group
			Threshold	Survival	Th. Location		M/C	Th. Location		M/C	Th. Location		M/C	
Heater line			[°C]	[°C]										
TCS Line 32	on FCV A2A	used	11/14	11/14	FCV A2A	THM-80	M+C	FCV A2A	THM-128	M+C	FCV A2A	THM-176	M+C	ET1
TCS Line 33	on FCV C4A	used	11/14	11/14	FCV C4A	THM-81	M+C	FCV C4A	THM-129	M+C	FCV C4A	THM-177	M+C	ET2
TCS Line 34	on FCV C3A	used	11/14	11/14	FCV C3A	THM-82	M+C	FCV C3A	THM-130	M+C	FCV C3A	THM-178	M+C	ET2
TCS Line 35	on RCS PIPES	used	19/20	19/20	RCS piping	THM-83	M+C	RCS piping	THM-131	M+C	RCS piping	THM-179	M+C	ET2
TCS Line 36	Propellant TANKS	used	N/A	N/A		THM-84	spare		THM-132	spare		THM-180	spare	ET2
TCS Line 37	on RCS PIPES	used	22/23	21/22	RCS piping	THM-85	M+C	RCS piping	THM-133	M+C	RCS piping	THM-181	M+C	ET2
TCS Line 38	close to GYRO	used	62.5/63.0	-24/-21	GYRO	THM-86	M+C	GYRO	THM-134	M+C	GYRO	THM-182	M+C	ET2
TCS Line 39	on FCV A1B	used	11/14	11/14	FCV A1B	THM-87	M+C	FCV A1B	THM-135	M+C	FCV A1B	THM-183	M+C	ET2
TCS Line 40	on FCV C2B	used	11/14	11/14	FCV C2B	THM-88	M+C	FCV C2B	THM-136	M+C	FCV C2B	THM-184	M+C	ET2
TCS Line 41	on FCV C1B	used	11/14	11/14	FCV C1B	THM-89	M+C	FCV C1B	THM-137	M+C	FCV C1B	THM-185	M+C	ET2
TCS Line 42	on FCV A2B	used	11/14	11/14	FCV A2B	THM-90	M+C	FCV A2B	THM-138	M+C	FCV A2B	THM-186	M+C	ET2
TCS Line 43	on FCV C4B	used	11/14	11/14	FCV C4B	THM-91	M+C	FCV C4B	THM-139	M+C	FCV C4B	THM-187	M+C	ET2
TCS Line 44	on FCV C3B	used	11/14	11/14	FCV C3B	THM-92	M+C	FCV C3B	THM-140	M+C	FCV C3B	THM-188	M+C	ET2
TCS Line 45	on RCS PIPES	used	19/20	23/24	RCS piping	THM-93	M+C	RCS piping	THM-141	M+C	RCS piping	THM-189	M+C	ET2
TCS Line 46	on RCS PIPES	used	19/20	19/20	RCS piping	THM-94	M+C	RCS piping	THM-142	M+C	RCS piping	THM-190	M+C	ET2
TCS Line 47	on RCS PIPES	used	24/25	27/28	RCS piping	THM-95	M+C	RCS piping	THM-143	M+C	RCS piping	THM-191	M+C	ET2
TCS Line 48	on unit: PT, LF, LV1, LV2	used	19/20	19/20	PT unit	THM-96	M+C	PT unit	THM-144	M+C	PT unit	THM-192	M+C	ET2

Note: C.L. = Control Law

HERSCHEL PLANCK

4.2 PLANCK THERMISTORS LIST

PLANCK	HEATER's location	Heater line status Used/spare Not-available	Unit ON	Unit OFF	MODULE = SIOH1			MODULE = SIOH2			MODULE = SIOH3			Group
			Threshold	Threshold	Th. Location		M/C	Th. Location		M/C	Th. Location		M/C	
Heater line			[°C]	[°C]										
TCS Line 01	close to STR 1	used	-19/-16	-29/-26	Star Tracker 1	THM-49	M+C	Star Tracker 1	THM-97	M+C	Star Tracker 1	THM-145	M+C	ET0
TCS Line 02	close to STR 2	used	-19/-16	-29/-26	Star Tracker 2	THM-50	M+C	Star Tracker 2	THM-98	M+C	Star Tracker 2	THM-146	M+C	ET0
TCS Line 03	close to DPU1	used	-9/-6	-19/-16	DPU1	THM-51	M+C	DPU1	THM-99	M+C	DPU1	THM-147	M+C	ET0
TCS Line 04	close to DPU2	used	-9/-6	-19/-16	DPU2	THM-52	M+C	DPU2	THM-100	M+C	DPU2	THM-148	M+C	ET0
TCS Line 05	close to REU	used	-9/-6	-19/-16	REU	THM-53	M+C	REU	THM-101	M+C	REU	THM-149	M+C	ET0
TCS Line 06	close to CCU, CEU	used	-9/-6	-18/-15	CCU	THM-54	M+C	CCU	THM-102	M+C	CCU	THM-150	M+C	ET0
TCS Line 07	on Heat Pipes	used	-14/-11 (BOL) -15/-14 (EOL)	-14/-11	heat pipe	THM-55	M+C	heat pipe	THM-103	M+C	heat pipe	THM-151	M+C	ET0
TCS Line 08	on Heat Pipes	used	-15/-12 (BOL) -16/-15 (EOL)	-15/-12	DAE	THM-56	M	DAE	THM-104	M	BEU	THM-152	M	ET0
TCS Line 09	on Heat Pipes	used	-16/-13 (BOL) -17/-16 (EOL)	-16/-13	BEU	THM-57	M	He3 tank +Z	THM-105	M	He3 tank +Z	THM-153	M	ET0
TCS Line 10	on Heat Pipes	used	-17/-14 (BOL) -18/-17 (EOL)	-17/-14	DCCU	THM-58	M	DCCU	THM-106	M		THM-154	spare	ET0
TCS Line 11	on Heat Pipes	used	-18/-15 (BOL) -19/-18 (EOL)	-18/-15	He4 tank 3 -Y	THM-59	M	He4 tank 3 -Y	THM-107	M		THM-155	spare	ET0
TCS Line 12	on Heat Pipes	used	-19/-16 (BOL) -20/-19 (EOL)	-19/-16	CEU (4KCDE)	THM-60	M	CEU (4KCDE)	THM-108	M	He4 tank 1 +Y	THM-156	M	ET0
TCS Line 13	on Heat Pipes	used	-20/-17 (BOL) -20/-19 (EOL)	-20/-17	He4 tank 1 +Y	THM-61	M		THM-109	spare		THM-157	spare	ET0
TCS Line 14	HELIUM tanks	used	-9/-6	-19/-16	He4 tank 2 -Z	THM-62	M+C	He4 tank 2 -Z	THM-110	M+C	He4 tank 2 -Z	THM-158	M+C	ET0
TCS Line 15	PAU	used	-9/-6	-19/-16	PAU	THM-63	M+C	PAU	THM-111	M+C	PAU	THM-159	M+C	ET0
TCS Line 16	CRU (4K Reg)	used	-9/-6	-19/-16	CRU(4K Reg)	THM-64	M+C	CRU(4K Reg)	THM-112	M+C	CRU(4K Reg)	THM-160	M+C	ET0
TCS Line 17		spare				THM-65	spare		THM-113	spare		THM-161	spare	ET1
TCS Line 18		spare				THM-66	spare		THM-114	spare		THM-162	spare	ET1
TCS Line 19		spare				THM-67	spare		THM-115	spare		THM-163	spare	ET1
TCS Line 20	Propellant TANKS	used	N/A	N/A		THM-68	spare		THM-116	spare		THM-164	spare	ET1
TCS Line 21	on TANK +Z+Y	used	11/14	11/14	TANK +Z+Y	THM-69	M+C	TANK +Z+Y	THM-117	M+C	TANK +Z+Y	THM-165	M+C	ET1
TCS Line 22	on TANK +Z-Y	used	11/14	11/14	TANK +Z-Y	THM-70	M+C	TANK +Z-Y	THM-118	M+C	TANK +Z-Y	THM-166	M+C	ET1
TCS Line 23	on TANK -Z	used	11/14	11/14	TANK -Z	THM-71	M+C	TANK -Z	THM-119	M+C	TANK -Z	THM-167	M+C	ET1
TCS Line 24	on FCV A1A	used	11/14	11/14	1 N FCV A1A	THM-72	M+C	1 N FCV A1A	THM-120	M+C	1 N FCV A1A	THM-168	M+C	ET1
TCS Line 25	on FCV B1A	used	11/14	11/14	1 N FCV B1A	THM-73	M+C	1 N FCV B1A	THM-121	M+C	1 N FCV B1A	THM-169	M+C	ET1
TCS Line 26	on FCV D1A	used	11/14	11/14	20N FCV D1A	THM-74	M+C	20N FCV D1A	THM-122	M+C	20N FCV D1A	THM-170	M+C	ET1
TCS Line 27	on FCV D2A	used	11/14	11/14	20N FCV D2A	THM-75	M+C	20N FCV D2A	THM-123	M+C	20N FCV D2A	THM-171	M+C	ET1
TCS Line 28	on FCV F1A	used	11/14	11/14	20N FCV F1A	THM-76	M+C	20N FCV F1A	THM-124	M+C	20N FCV F1A	THM-172	M+C	ET1
TCS Line 29	on FCV F2A	used	11/14	11/14	20N FCV F2A	THM-77	M+C	20N FCV F2A	THM-125	M+C	20N FCV F2A	THM-173	M+C	ET1

HERSCHEL PLANCK

 DOC : H-P-TN-AI-0069
 ISSUE : 05
 DATE : 05/AUG/05
 PAGE : 91 of 91
 CLASS : DC

PLANCK Heater line	HEATER's location	Heater line status Used/spare Not-available	Unit ON Threshold	Unit OFF Threshold	MODULE = SIOH1			MODULE = SIOH2			MODULE = SIOH3			Group
			[°C]	[°C]	Th. Location		M/C	Th. Location		M/C	Th. Location		M/C	
TCS Line 30	on FCV U1A	used	11/14	11/14	20N FCV U1A	THM-78	M+C	20N FCV U1A	THM-126	M+C	20N FCV U1A	THM-174	M+C	ET1
TCS Line 31	on FCV U2A	used	11/14	11/14	20N FCV U2A	THM-79	M+C	20N FCV U2A	THM-127	M+C	20N FCV U2A	THM-175	M+C	ET1
TCS Line 32	on RCS units	used	19/20	19/20	PT unit	THM-80	M+C	PT unit	THM-128	M+C	PT unit	THM-176	M+C	ET1
TCS Line 33	on RCS PIPES	used	28/29	21/22	RCS piping	THM-81	M+C	RCS piping	THM-129	M+C	RCS piping	THM-177	M+C	ET2
TCS Line 34	on RCS PIPES	used	23/24	19/20	RCS piping	THM-82	M+C	RCS piping	THM-130	M+C	RCS piping	THM-178	M+C	ET2
TCS Line 35	close to CAU	used	-9/-6	-19/-16	CAU	THM-83	M+C	CAU	THM-131	M+C	CAU	THM-179	M+C	ET2
TCS Line 36	close to REBA1, REBA2	used	-19/-16	-29/-26	REBA 2	THM-84	M+C	REBA 2	THM-132	M+C	REBA 2	THM-180	M+C	ET2
TCS Line 37	inside BATTERY	used	1/4	1/4	BATTERY	THM-85	M+C	BATTERY	THM-133	M+C	BATTERY	THM-181	M+C	ET2
TCS Line 38	on FCV A1B	used	11/14	11/14	1 N FCV A1B	THM-86	M+C	1 N FCV A1B	THM-134	M+C	1 N FCV A1B	THM-182	M+C	ET2
TCS Line 39	on FCV B1B	used	11/14	11/14	1 N FCV B1B	THM-87	M+C	1 N FCV B1B	THM-135	M+C	1 N FCV B1B	THM-183	M+C	ET2
TCS Line 40	on FCV D1B	used	11/14	11/14	20N FCV D1B	THM-88	M+C	20N FCV D1B	THM-136	M+C	20N FCV D1B	THM-184	M+C	ET2
TCS Line 41	on FCV D2B	used	11/14	11/14	20N FCV D2B	THM-89	M+C	20N FCV D2B	THM-137	M+C	20N FCV D2B	THM-185	M+C	ET2
TCS Line 42	on FCV F1B	used	11/14	11/14	20N FCV F1B	THM-90	M+C	20N FCV F1B	THM-138	M+C	20N FCV F1B	THM-186	M+C	ET2
TCS Line 43	on FCV F2B	used	11/14	11/14	20N FCV F2B	THM-91	M+C	20N FCV F2B	THM-139	M+C	20N FCV F2B	THM-187	M+C	ET2
TCS Line 44	on FCV U1B	used	11/14	11/14	20N FCV U1B	THM-92	M+C	20N FCV U1B	THM-140	M+C	20N FCV U1B	THM-188	M+C	ET2
TCS Line 45	on FCV U2B	used	11/14	11/14	20N FCV U2B	THM-93	M+C	20N FCV U2B	THM-141	M+C	20N FCV U2B	THM-189	M+C	ET2
TCS Line 46	on RCS PIPES	used	29/30	21/22	RCS piping	THM-94	M+C	RCS piping	THM-142	M+C	RCS piping	THM-190	M+C	ET2
TCS Line 47	on RCS PIPES	used	29/30	20/21	RCS piping	THM-95	M+C	RCS piping	THM-143	M+C	RCS piping	THM-191	M+C	ET2
TCS Line 48	on RCS PIPES	used	19/20	19/20	RCS piping	THM-96	M+C	RCS piping	THM-144	M+C	RCS piping	THM-192	M+C	ET2