

Title: **HERSCHEL EQM Thermal Model and Analysis**

CI-No:

Prepared by:	J. Hinger <i>J. Hinger</i>	Date:	17 May 2002
Checked by:	J. Kroeker <i>J. Kroeker</i>		11.06.02
Product Assurance:	R. Stritter <i>R. Stritter</i>		11.06.02
Configuration Control:	A. v. Ivády <i>A. v. Ivády</i>		11.06.02
Project Management:	W. Rühle/ K. Moritz <i>W. Rühle</i>		11.06.02

Distribution: Preliminary Information for internal distribution only

Copying of this document, and giving it to others and the use or communication of the contents thereof, are forbidden without express authority. Offenders are liable to the payment of damages. All rights are reserved in the event of the grant of a patent or the registration of a utility model or design.

Issue	Date	Sheet	Description of Change	Release
1	26/02/02	all	First formal issue	
2	17/05/02	7 10 23 30 39 47 49 ff 101ff 113 ff 124ff 135ff	Analysis of helium-cooled cover shield added. Transient analysis for cool-down added. Alternative design with helium-cooled vacuum-tight plate / shield design added. § 4.2.5: Auxiliary tank mounting straps linked to Ti-heads of upper spatial framework interface (node 8) instead of to Main Tank. Hell changed to Hel in Fig. 4-12 "Preliminary" inserted. coupling between node 1128 and node 1121 erased in Fig 4-34 Chapter 4.6 "Submodel "CPLATE", CTA Cold Plate for EQM" inserted. Chapter 5.5 "CTA Cold Plate Design 1" inserted Chapter 5.6 "CTA Cold Plate Design 2" inserted Chapter 5.7 "Transient Thermal Analysis" inserted Conclusions modified	

Table of Content

1	SCOPE	8
2	Applicable and Reference Documents	9
2.1	Applicable Documents	9
2.2	Reference Documents	9
2.3	Abbreviations	10
3	EQM Test Description	11
3.1	EQM Test Configuration	11
3.2	EQM Thermal Test Objectives	13
3.3	Thermal Requirements	13
4	Thermal Design and Thermal-Mathematical Model Description	15
4.1	TMM Submodel Structure	15
4.2	Submodel “CRYO”	16
4.2.1	General CRYO-TMM Description	16
4.2.2	Harness Thermal Modelling	17
4.2.3	Tank Suspension Thermal Modelling	22
4.2.4	LOU Window Thermal Modelling	22
4.2.5	Particular EQM-relevant Design Details:	24
4.3	Submodel “VENT”	26
4.4	Submodel “PAYLOAD”	31
4.4.1	General PAYLOAD-TMM Description	31
4.4.2	OB-Ventline Modelling	37
4.5	Submodel “CTCE”, Cryo Test Cavity for EQM	42
4.5.1	CTCE Requirements	42
4.5.2	CTCE Thermal Design Concepts	42
4.5.3	CTCE Ventline Design and Modelling	46
4.5.4	Geometrical-mathematical Model of Cryogenic Test Cavity	49
4.6	Submodel “CPLATE”, CTA Cold Plate for EQM	50
4.6.1	CTA Coldplate Requirements	51
4.6.2	CTA Coldplate Design concept	51
5	Thermal Analysis Results	52

5.1	CTCE-Design-1 Case 1	53
5.2	CTCE-Design-1 Case 2	66
5.3	CTCE-Design-1 Case 3	79
5.4	CTCE-Design-2 Case 2 b	92
5.5	CTA Cold Plate Design 1	105
5.6	CTA Cold Plate Design 2	116
5.7	Transient Thermal Analysis	127
5.7.1	Cool-down of CTCE-Cryostat, Design Concept 2	127
5.7.2	Cool-down of CTA Cold Plate Design	131
6	Ventline Pressure Drop Analysis	134
6.1	Pressure Drop within EQM-Auxiliary Tank Ventline	134
6.2	Pressure Drop within the EQM-main Tank Ventline	134
6.3	Pressure Drop within the CTCE Ventline	134
7	Conclusions	135

Table of Figures

Figure 3-1: EQM Testconfiguration	12
Figure 4-1: ESATAN Thermal-Mathematical Model hierarchy of EQM.....	15
Figure 4-3: Thermal nodes distribution of EQM-cryostat TMM	16
Figure 4-5: Harness interfaces between \$PAYLOAD and \$CRYO.....	21
Figure 4-7: Thermal nodes distribution of tank-suspensions	22
Figure 4-9: LOU window thermal nodes and interfaces.....	23
Figure 4-11: PFM rigid bar L0-link design.....	25
Figure 4-12: Thermal nodes and thermal network of submodel \$VENT (main tank ventline) with interfaces to submodel \$CRYO.....	30
Figure 4-14: Thermal nodes distribution of HERSCHEL-PL TMM \$PAYLOAD with interfaces to TMM \$CRYO	32
Figure 4-16: Nodal distribution of ESARAD model of HERSCHEL payload.....	33
Figure 4-18: Beam Pattern for the three Instruments	34
Figure 4-20: Thermal nodes distribution of instrument "PACS"	34
Figure 4-22: Thermal nodes distribution of instrument "SPIRE"	35
Figure 4-24: Thermal nodes distribution of instrument "HIFI"	35
Figure 4-26: Optical Bench ventline model.....	41
Figure 4-28: CTCE-design1 outline and thermal nodes distribution.....	44
Figure 4-30: CTCE-design2 outline and thermal nodes distribution.....	45
Figure 4-32: Thermal design of Reflector attachment	46
Figure 4-34: CTA ventline model	47
Figure 4-36: Example for a low-conductive joint.....	48
Figure 4-38: ESARAD-model of CTCE/cryostat cavity.....	49
Figure 4-40: Vacuum-tight Plate Design, Thermal network.....	50
Figure 5-1: Temperature evolution of CTA-shrouds during cool-down of CTA.....	127
Figure 5-2: Temperature evolution of CTA-heatshields during cool-down of CTA ...	128
Figure 5-3: Temperature evolution of CTA-reflector during cool-down of CTA	128

Figure 5-4: Temperature evolution of HERSCHEL Optical Bench during cool-down of CTA	129
Figure 5-5: Temperature evolution of Instruments during cool-down of CTA	129
Figure 5-6: Temperature evolution of Instruments during cool-down of CTA	130
Figure 5-7: Temperature evolution of Instruments during cool-down of CTA	130
Figure 5-8: Temperature evolution of CTA during cool-down of CTA.....	131
Figure 5-9: Temperature evolution of HERSCHEL Optical Bench during cool-down of CTA	132
Figure 5-10: Temperature evolution of Instruments during cool-down of CTA.....	132
Figure 5-11: Temperature evolution of Instruments during cool-down of CTA.....	133

List of Tables

Table 3-1: Level 0 temperature requirements of instruments	13
Table 3-3: Level 1 temperature requirements of instruments	14
Table 3-5: Level 2 temperature requirements of instruments	14
Table 4-1: Average dissipations of instruments (from RD 14)	36
Table 5-1: Input parameters	53
Table 5-3: Brief results summary	54
Table 5-5: Input parameters	66
Table 5-7: Brief results summary	67
Table 5-9: Input parameters	79
Table 5-11: Brief results summary	80
Table 5-13: Input parameters	92
Table 5-15: Brief results summary	93
Table 5-17: Input parameters	105
Table 5-18: Temperature results summary, CTA Cold Plate Design 1	105
Table 5-19: Input parameters	116
Table 5-20: Temperature results summary, CTA Cold Plate Design 2	116

1 SCOPE

This technical note reports on the thermal analyses and thermal design developed for the Engineering Qualification Model (EQM). A comprehensive description of the thermal-mathematical models as well as a brief description of relevant design details are included. Two different thermal design concepts of the cryogenic test adapter for the EQM (CTCE) are investigated, one with and another without the application of multilayer-insulation (MLI) blankets. Also thermal design concepts for the attachment and cooling-system of the reflector within the CTCE are proposed and analysed. As an alternative to the CTA-cryostats a helium-cooled cover shield is analysed.

Temperatures heater powers and helium mass flow rates are predicted for different design concepts and operating parameters. Analysis are performed for steady-state test conditions as well as for transient cool-down at ambient air.

2 Applicable and Reference Documents

2.1 Applicable Documents

- AD 01 HERSCHEL/PLANCK Instrument Interface Document IID Part A, Doc.No.: SCI-PT-IIDA-04624, Issue 2/0, 31.07.2001
- AD 02 HERSCHEL/PLANCK Instrument Interface Document IID Part B for PACS, Doc.No.: SCI-PT-IIDB/HIFI-02126, Issue 2/0, 31.07.2001
- AD 03 HERSCHEL/PLANCK Instrument Interface Document IID Part B for SPIRE, Doc.No.: SCI-PT-IIDB/HIFI-02124, Issue 3/0 (TBD), to be issued
issue 2/0 shall be updated according to change requests HR-SP-RAL-ECR-009-v2 and ECR-011
- AD 04 HERSCHEL/PLANCK Instrument Interface Document IID Part B for HIFI, Doc.No.: SCI-PT-IIDB/HIFI-02125, Issue 2/0, 31.07.2001
- AD 05 H-EPLM Environment & Test Requirements Specification, Doc.No.: HP-2-ASED-SP-0004, 21.11.01
- AD 06 HERSCHEL/PLANCK System Requirements Specification, Doc.No.: SCI-PT-RS-05991, Issue 2, 13.07.2001
- AD 07 HERSCHEL PLM Interface Specification, Doc.No.: HP-2-ASPI-IS-0039, Issue 1/1, 27.07.2001
- AD 08 HERSCHEL PLM / EQM AIT Plan, Doc.No.: HP-2-ASED-PL-0022, Draft, dated 16.01.2002
- AD 09 EQM Test Program Definition, Doc. No. HP-2-ASED-TN-0004, iss. 1, dated 03.08.2001

2.2 Reference Documents

- RD 01 H-EPLM Design Description; Doc.No.: HP-2-ASED-RP-0003_1_H-EPLM, 24.07.01
- RD 02 Herschel Ventline Heat Exchanger Layout, Doc.No. HP-2-ASED-TN-0027, 14.12.2001
- RD 03 HPLM Thermal Model and Analysis, Doc.No. HP-2-ASED-RP-0011, 30.11.2001
- RD 04 Analysis of Change Requests:SPIRE ECR #9 and #11, Doc.No. HP-2-ASED-TN-0038, 11.02.2002
- RD 05 Herschel PLM Drawings: CVV PFM Upper bulkhead, HP-2-ASED-0004
CVV PFM cylinder, HP-2-ASED-0005
CVV PFM lower bulkhead, HP-2-ASED-0006
- RD 06 Herschel EQM Drawings: CVV EQM Upper bulkhead, HP-2-ASED-0007
CVV EQM Intermediate ring, HP-2-ASED-0008
- RD 07 Procurement Specification for FIRST MLI, Doc.No.: FIRST-PS-BCB00.001, 11.08.2000
- RD 08 FIRST PLM MLI, Technical Proposal from AAE, Doc.No.: MS-PRO-0250-AAE, 04.10.2000

- RD 09 Evaluation of LINDE/ESTEC-MLI Measurements and Transformation to the ISO Cryostat MLI Design, Doc.No.: ISO.TN-B1430.007, 12.07.1988
- RD 10 M. Sander: ISO-PLM Test Evaluation with Thermopt, Doc.No.: ESA SP-324, December 1991
- RD 11 PACS FPU Drawing No. PACS-KT-ICD-0000W1.22, 04.09.2001
- RD 12 SPIRE Interface Drawing No. 5264 300, 30.07.2001
- RD 13 HIFI-FPU External Configuration Drawing No. 455-3-001-0, 29.05.2001
- RD 14 Reduced instrument TMMs provided by ESA, Doc.No.: SCI-PT/09948, 04.10.2001
- RD 15 ISO-TMM "MD0600.esat", version 6.00, M. Sander DASA / RIT71, 24.02.1994
- RD 16 ISO-TMM "PL0600.esat", version 6.00, M. Sander DASA / RIT71, 24.02.1994
- RD 17 ISO-TMM "V0300.esat", version 3.00, M. Sander DASA / RIT71, 24.02.1994
- RD 18 ISO-FM Thermal Test Prediction Analysis, Doc.No. ISO-AN-B1430.022, iss. 1, 08.12.1994
- RD 19 Functional, Design and Interface Requirements for EQM Cryo Test Adapter (CTA), Draft, to be issued

2.3 Abbreviations

ASED	Astrium GmbH
ASPI	Alcatel Space
BOL	Begin of Life
CTA	cryogenic test adapter
CTCE	cryogenic test cavity for EQM
CVV	Cryostat Vacuum Vessel
EOL	End of Life
EQM	Engineering Qualification Model
FM	flight model
HPLM	HERSCHEL payload module
I/F	interface
IR	InfraRed
MLI	multi layer insulation
NA	not applicable
OB	optical bench
PFM	proto flight model
PLM	payload module
SVM	service moule
TBC	to be confirmed
TBD	to be defined
TMM	Thermal Mathematical Model
QM	qualification model
w.r.t.	with regard to

3 EQM Test Description

3.1 EQM Test Configuration

The EQM test configuration is described in detail in AD 08 and AD 09. The configuration as illustrated in Figure 3-1 emphasizes all thermal aspects. The whole EQM test configuration comprises of:

- The modified ISO-cryostat with the main tank torus and an auxiliary tank
- The HERSCHEL payload with the optical bench and the instrument QMs
- The cryogenic test cavity for the EQM (CTCE) with the reflector, black body and the antenna
- External Hel – dewar for vapor-cooling of the CTA-shrouds and the black body
- EGSE (not depicted in Figure 3-1) with the power supplies for the heater circuits

The lower part of the ISO-QM-cryostat is used for the HERSCHEL-EQM without any major changes. The ISO-telescope with baffle of course has to be dismantled. The upper part of the ISO-cryostat (cone with cover), however, can not be used for the HERSCHEL-EQM and has to be replaced by a special bulkhead. This bulkhead is identical to the FM-bulkhead with the exception that its height is shortened by 180 mm. Between bulkhead and CVV of the ISO-cryostat a special connector-interface ring of 180 mm height is inserted.

For the tests underlying the thermal analysis in this report the cryostat cover is not existent but the cryostat opening is covered by a cryogenic test cavity (CTCE). This part is a separate cryostat consisting of a vacuum vessel and vapor-cooled shields. The vessel is mounted onto the CTA-flange of the upper CVV-bulkhead and hermetically sealed by an O-ring.

The CTCE contains a reflector and a blackbody for the “dark-background test”. In this test the thermal influence of the non-existent telescope is simulated by the reflector that is temperature controlled at 40 K to 80 K. The observation target for the instruments is simulated by the black body controlled at < 5 K. In order to avoid thermal disturbances and straylight the internal CTCE walls are coated by a vapor-cooled shroud at a temperature of < 5 K.

The helium gas for the cooling of the CTCE-shroud and black body is provided by an external Hel – dewar.

As an alternative to the CTCE a vacuum-tight plate similar to the PFM cryostat cover with a helium-cooled cover shield is thermally analysed. In this case neither a reflector nor a blackbody target is needed.

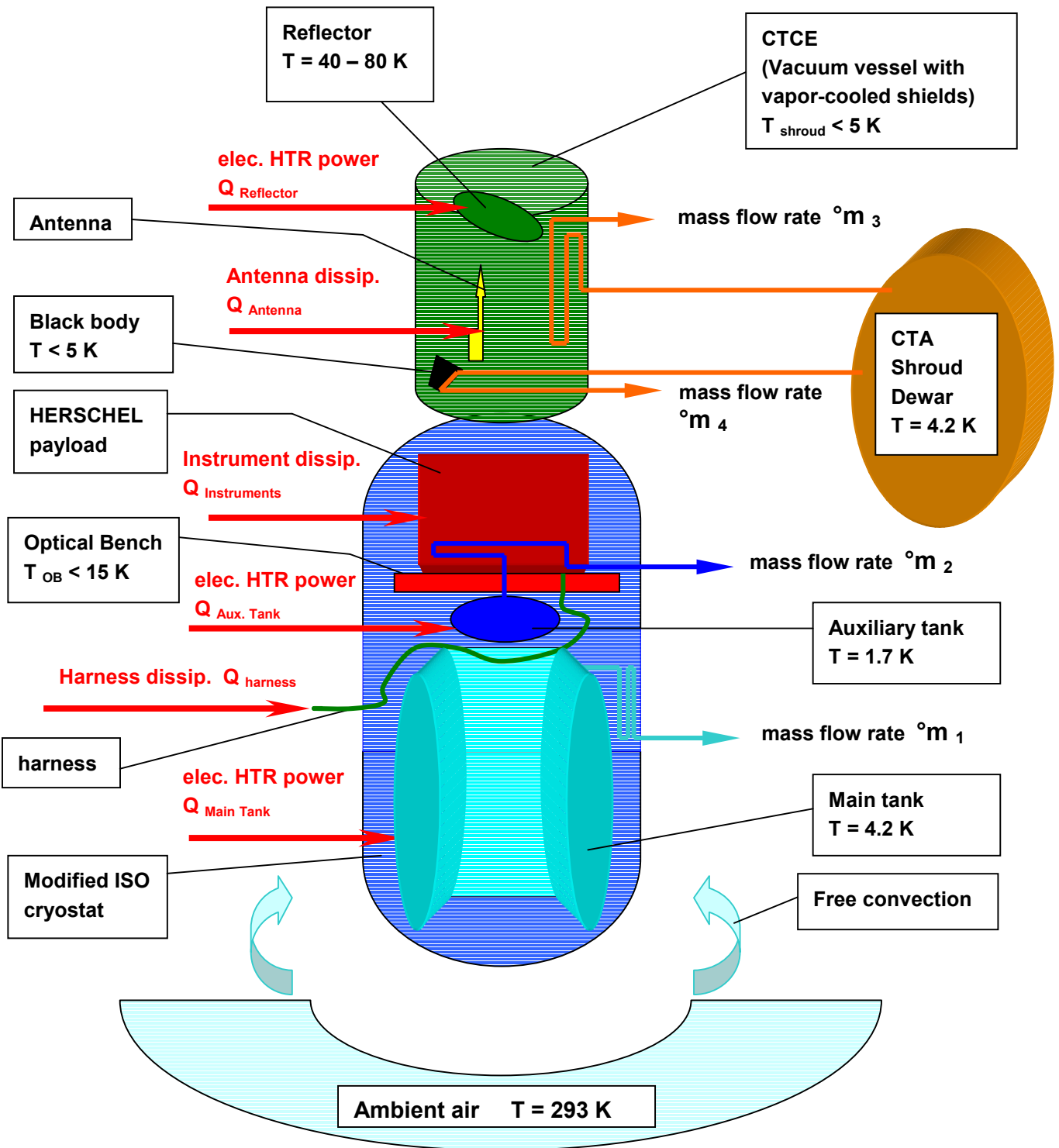

Figure 3-1: EQM Testconfiguration

3.2 EQM Thermal Test Objectives

As stated in AD 08 the following test objectives are identified:

- Functional test of the scientific instruments
- EMC test
- Dark background test
- Verification of the alignment procedure
- Pre-validation of the Payload thermal design
- Verification of the Payload integration procedure
- First functional check of the EGSE (H/W and S/W) and EGSE Test Procedure preparation/evaluation

3.3 Thermal Requirements

During the EQM test the HERSCHEL payload consisting of the instrument flight-representative QMs and the OB shall be operated in a flight-representative thermal environment and shall meet the thermal requirements specified in AD2, AD3 and AD4 for the operational conditions in flight.

As specified in AD2, AD3 and AD4 the temperature reference points of the instruments shall be kept within the temperature ranges depending on the respective temperature levels compiled in Table 3-1 thru Table 3-5.

<i>Instrument Level-0 - I/F</i>	<i>Tmin</i>	<i>Tmax</i>	<i>Level 0 max. heat flow on strap (mW)</i>	<i>Level 0 heat dissipation on respective thermal node (mW)</i>	<i>Stability</i>	<i>Reference</i>
	<i>(K)</i>	<i>(K)</i>				
<i># 811 SPIRE SM Detector enclosure</i>	TBD	1.80	5	NA	NA	*) AD 03
<i># 819 SPIRE Cooler Pump HS</i>	TBD	1.80	2	NA	NA	*) AD 03
<i># 820 SPIRE Cooler Evaporator HS</i>	TBD	1.80	1	NA	NA	*) AD 03
<i># 765 PACS Blue Detector</i>	1.6	3.50	NA	0.8	NA	AD 02
<i># 760 PACS Red Detector</i>	1.6	1.75	NA	0	NA	AD 02
<i># 781 PACS He-Pump</i>	1.6	2.20	NA	7.61	NA	AD 02
<i># 912 HIFI I0-Boundary</i>	0	2.00	"see TMM"	"see TMM"	6 mK/100s	AD 04

*) stated in change request HR-SP-RAL-ECR-009-v2, not yet agreed by ASED

Table 3-1: Level 0 temperature requirements of instruments

Instrument Level-1 - I/F	Tmin (K)	Tmax (K)	Level 1 heat load on strap (mW)	Stability	Reference
SPIRE L1-interface	TBD	*) 4.5	*) 13	NA	*) AD 03
PACS Photometer Optics	3	5	“from TMM”	NA	AD 02
PACS Collimator	3	5	“from TMM”	NA	AD 02
PACS Spectrom. Housing	3	5	“from TMM”	NA	AD 02
HIFI L1-interface	TBD	6	“from TMM”	6 mK/100s	AD 01

*) stated in change request HR-SP-RAL-ECR-009-v2, not yet agreed by ASED

Table 3-3: Level 1 temperature requirements of instruments

Instrument Level-2 - I/F	Tmin (K)	Tmax (K)	Level 2 heat load on FPU (mW)	Stability	Reference
#801, 802 SPIRE JFETs	TBD	15	“from TMM”	NA	AD 03
PACS	NA	NA	NA	NA	AD 02
#910 HIFI FPU Structure	TBD	20	“from TMM”	15 mK/100s	AD 01

Table 3-5: Level 2 temperature requirements of instruments

In order to meet the a.m. requirements it is mandatory to expose the HERSCHEL payload consisting of the OB with instruments, instrument shield and instrument shield MLI to an thermal environment identical or at least similar to the flight-environment. This is achieved by the following measures:

- Cooling the innermost heatshield (HS1) of the EQM-cryostat to a temperature at or below the flight-level of 30 K. This shall be done by adequate heating of the main tank resulting in an adequate helium mass flow rate.
- Controlling the auxiliary tank temperature at flight-representative value (currently 1.7 K)
- Using similar thermal links between instrument L0-interfaces and auxiliary tank as for the FM. Since the auxiliary EQM-tank is smaller in diameter than the optical bench additional “tank-interface-brackets” shall be provided which allow the same L0-strap routing as for the FM. If this is not possible the EQM-cooling straps shall be tailored in order to achieve flight-relevant instrument L0-temperatures. Anyhow the same tank/strap interface design shall be provided for the EQM as for the PFM.
- Adjustment of a flight-representative mass flow rate of approximately 2.1 mg/s (see RD 03) for the payload-ventline. This shall be achieved by an adequate thermal decoupling of the auxiliary tank (1.7K) from the main tank (4.2 K) and by adjusting the electrical heater power of the auxiliary tank.
- Avoid an excessive infrared heat flow onto the instruments and OB by an adequate baffling of the cryostat opening. This is intended to be obtained by a baffle penetrating the cryostat opening. The baffle shall be coupled to the vapor-cooled shroud of the CTCE that is cooled beyond 5 K.
Note: Analysis demonstrated that an infrared heat flow of 3.5 Watts ! would be absorbed by the payload if the cryostat opening was not baffled and exposed to ambient temperature (293 K). In this case the a.m. requirements would by far not be met!

4 Thermal Design and Thermal-Mathematical Model Description

4.1 TMM Submodel Structure

The ESATAN TMMs are defined as independent submodels (submodel-technique) assembled to an overall EQM model. The model hierarchy is illustrated in Figure 4-1.

The ventline model \$VENT is based on the one developed for ISO (see RD 17). It computes the heat exchanges by forced convection between gaseous helium and the ventline walls as well as the heat transfer by advection within the main tank ventline. Pressure drop computation, however, has been deleted in order to avoid numerical instabilities. A brief pressure drop analysis is performed in § 6.

The submodel \$PAYLOAD exactly corresponds to the payload-TMM used in the HPLM TMM (see RD 03). It includes the instrument TMMs delivered by ESA (see RD 14). The L0-cooling strap cross-sections between the instrument L0-interfaces and the EQM-auxiliary tank, however, are adapted to the latest instrument requirements w.r.t. AD 02, AD 03, AD04.

The submodel \$CRYO comprises the EQM-cryostat with CVV, heatshields, main tank and auxiliary tank and includes the submodels \$PAYLOAD and \$VENT.

The submodel \$CTCE comprises the cryogenic test cavity for EQM.

Concerning thermal node and network identifications and definitions the submodels are explained in detail in the following sections. Conductors and node data as well as subroutine definitions and material data are included in the appropriate ESATAN-files. Due to the excessive extent the complete listings are not contained in this report. The models will be delivered to ESA in electronic form.

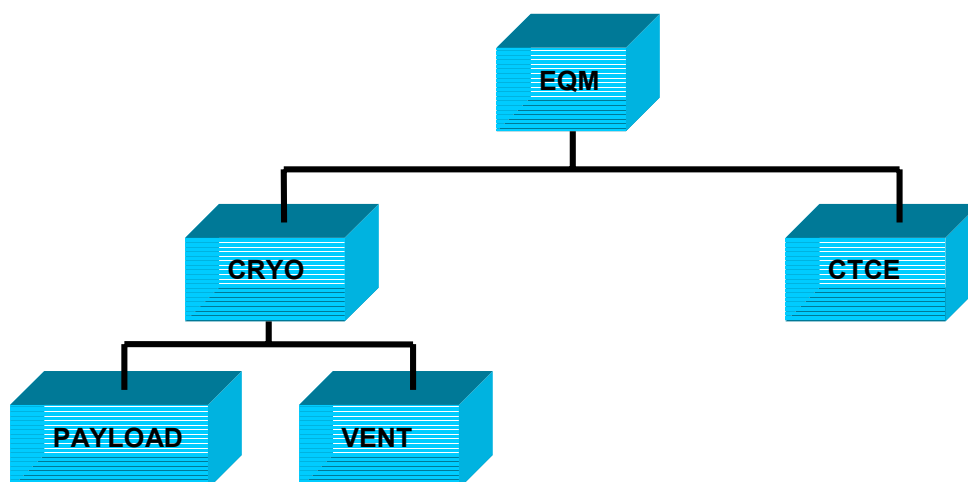

Figure 4-1: ESATAN Thermal-Mathematical Model hierarchy of EQM

4.2 Submodel “CRYO”

4.2.1 General CRYO-TMM Description

The submodel \$CRYO comprises the EQM thermostat including CVV, heatshields, MLI-blankets, main and auxiliary tank, spatial frameworks etc. and includes the submodels \$PAYLOAD and \$VENT. The thermal node indentifiers and thermal node defintions are shown in Figure 4-3. The included submodels are not depicted in Figure 4-3.

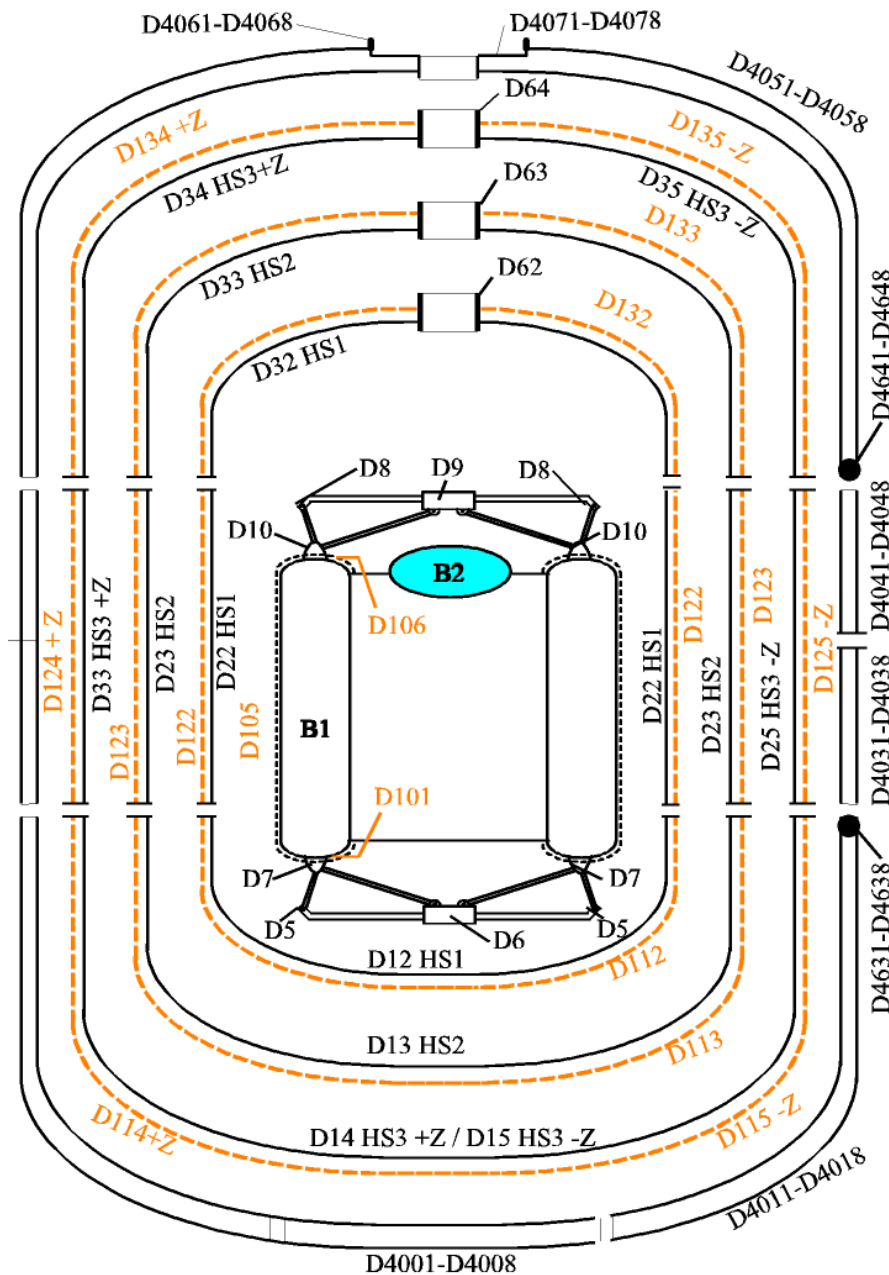

Figure 4-3: Thermal nodes distribution of EQM-cryostat TMM

4.2.2 Harness Thermal Modelling

The harness node definitions and interfaces are shown in Figure 4-5. Each harness node is subjected to a heat dissipation. The dissipations are copied from the HPLM model (see RD 03) and can be found in the original program code, listed below. The connector interface ring used for the EQM is represented by the nodes 4731 to 4738 (plug sections) evenly distributed along the perimeter. Due to absence of approved data it is assumed that the two harness bundles (copied from the HPLM model) are routed to the plug sections 4731 and 4738 only. The knowledge about the exact plug position, however, is not important for thermal aspects. The original ESATAN-program code to compute the harness conductances are listed below:

```
# -----
# Harness within CVV, copied from model herschel_delivered.d from 30.11.01
# -----
#
#                                     HARNESS
# copied from herschel_delivered.d from 30.11.01
# -----
#
# cables are modelled by one conductor as a sum of several terms,
# one per material:
#   argument 1 = stainless steel           mm^2
#   argument 2 = brass                     mm^2
#   argument 3 = teflon (insulation)       mm^2
#   argument 4 = commercial copper        mm^2
#   argument 5 = Vespel                    mm^2
#   argument 6 = copper-beryllium         mm^2
#   argument 7 = copper-nickel            mm^2
#   argument 8 = length                    m
#   argument 9 = temperature 1             K
#   argument 10 = temperature 2           K
#
# modification by J. Hinger: X2-harness routed to CVV-plug 4731
#                               X3-harness routed to CVV-plug 4738
GL(4731,6051) = FCAB(X2SST,X2BRAS,X2PTFE,X2CCU,X2VESP,X2CUBE,X2CUMN, X2L*.20D0, T4731, T6051);
GL(6051,6052) = FCAB(X2SST,X2BRAS,X2PTFE,X2CCU,X2VESP,X2CUBE,X2CUMN, X2L*.20D0, T6051, T6052);
GL(6052,6053) = FCAB(X2SST,X2BRAS,X2PTFE,X2CCU,X2VESP,X2CUBE,X2CUMN, X2L*.20D0, T6052, T6053);
GL(6053,6054) = FCAB(X2SST,X2BRAS,X2PTFE,X2CCU,X2VESP,X2CUBE,X2CUMN, X2L*.20D0, T6053, T6054);
GL(6054,6055) = FCAB(X2SST,X2BRAS,X2PTFE,X2CCU,X2VESP,X2CUBE,X2CUMN, X2L*.20D0, T6054, T6055);
#
GL(6055,6056) = FCAB(X2SST,X2BRAS,X2PTFE,X2CCU,X2VESP,X2CUBE,X2CUMN, X2IL*.25D0, T6055, T6056);
GL(6056,6057) = FCAB(X2SST,X2BRAS,X2PTFE,X2CCU,X2VESP,X2CUBE,X2CUMN, X2IL*.25D0, T6056, T6057);
GL(6057,6058) = FCAB(X2SST,X2BRAS,X2PTFE,X2CCU,X2VESP,X2CUBE,X2CUMN, X2IL*.25D0, T6057, T6058);
#
GL(4738,6061) = FCAB(X3SST,X3BRAS,X3PTFE,X3CCU,X3VESP,X3CUBE,X3CUMN, X3L*.20D0, T4738, T6061);
GL(6061,6062) = FCAB(X3SST,X3BRAS,X3PTFE,X3CCU,X3VESP,X3CUBE,X3CUMN, X3L*.20D0, T6061, T6062);
GL(6062,6063) = FCAB(X3SST,X3BRAS,X3PTFE,X3CCU,X3VESP,X3CUBE,X3CUMN, X3L*.20D0, T6062, T6063);
GL(6063,6064) = FCAB(X3SST,X3BRAS,X3PTFE,X3CCU,X3VESP,X3CUBE,X3CUMN, X3L*.20D0, T6063, T6064);
GL(6064,6065) = FCAB(X3SST,X3BRAS,X3PTFE,X3CCU,X3VESP,X3CUBE,X3CUMN, X3L*.20D0, T6064, T6065);
#
GL(6065,6066) = FCAB(X3SST,X3BRAS,X3PTFE,X3CCU,X3VESP,X3CUBE,X3CUMN, X3IL*.25D0, T6065, T6066);
GL(6066,6067) = FCAB(X3SST,X3BRAS,X3PTFE,X3CCU,X3VESP,X3CUBE,X3CUMN, X3IL*.25D0, T6066, T6067);
GL(6067,6068) = FCAB(X3SST,X3BRAS,X3PTFE,X3CCU,X3VESP,X3CUBE,X3CUMN, X3IL*.25D0, T6067, T6068);
#
# CVV-plugs to HS1, modification by J. Hinger
#
GL( 4732, 22 ) = 0.25* FCAB(4.99D0,2.75D0,36.0D0,0.0D0,0.0D0,0.0D0,0.0D0, 0.25D0, T4732, T22);
GL( 4733, 22 ) = 0.25* FCAB(4.99D0,2.75D0,36.0D0,0.0D0,0.0D0,0.0D0,0.0D0, 0.25D0, T4733, T22);
GL( 4734, 22 ) = 0.25* FCAB(4.99D0,2.75D0,36.0D0,0.0D0,0.0D0,0.0D0,0.0D0, 0.25D0, T4734, T22);
GL( 4735, 22 ) = 0.25* FCAB(4.99D0,2.75D0,36.0D0,0.0D0,0.0D0,0.0D0,0.0D0, 0.25D0, T4735, T22);
#
# HS1 to spatial framework
#
GL( 8, 22 ) = FCAB(0.45D0, 1.02D0, 4.00D0, 0.0D0, 0.0D0, 0.0D0, 0.0D0, 1.50D0, T8, T22); # up
```

```

#
GL(8,PLM:376)=FCAB(0.45D0, 1.02D0, 4.00D0, 0.0D0, 0.0D0, 0.0D0, 0.0D0, 0.50D0, T8, T:PLM:376);
# up
#
GL(6058,PLM:6059)=FCAB(X2SST,X2BRAS,X2PTFE,X2CCU,X2VESP,X2CUBE,X2CUMN,X2IL/4.0D0,T6058,T:PLM:6059)
#
GL(6068,PLM:6069)=FCAB(X3SST,X3BRAS,X3PTFE,X3CCU,X3VESP,X3CUBE,X3CUMN,X3IL/4.0D0,T6068,T:PLM:6069)

#      Function Subroutine FCAB copied from HERSCHEL-model, delivered 30.11.2001
#
#      DOUBLE PRECISION FUNCTION FCAB(HSST,HBRAS,HPTFE,HCCU,HVESP,HCUBE,HCUMN,HL,TEM1,TEM2)
#
#      FCAB CALCULATES THE THERMAL CONDUCTANCE (W/K) FOR THE HARNESS CONDUCTORS
#
#      THE INPUT ARGUMENTS ARE:
#      HSST      CROSS SECTION OF SST-PART                mm**2
#      HBRAS     "      "      "      BRASS-PART          mm**2
#      HPTFE     "      "      "      TEFLON-PART (INSULATION) mm**2
#      HCCU      "      "      "      Commercial Copper    mm**2
#      HVESP     "      "      "      KAPTON-PART (INSULATION) mm**2
#      HCUBE     "      "      "      Copper-Beryllium     mm**2
#      HCUMN     "      "      "      Copper-Nickel       mm**2
#
#      HL        LENGTH OF THE CABLE                      m
#      TEM1      TEMPERATURE OF 1ST ATTACHED NODE        K
#      TEM2      "      "      2ND      "      "          K
#
#      THE RESULTING VALUE IS MULTIPLIED BY THE USER CONSTANT FMHAR
#
#      DOUBLE PRECISION HSST, HBRAS, HPTFE, HCCU, HVESP,
#      f              HCUBE, HCUMN,
#      f              HL, TEM1, TEM2, TM
#
#      IF ( ABS(TEM1-TEM2) .LT. 1.D0 ) THEN
#
#      TM      =      .5D0 * (TEM1+TEM2)
#
#      FCAB = HSST * INTRP1( TM, TAB2, 1) +
#      f      HBRAS * INTRP1( TM, TAB10, 1) +
#      f      HPTFE * INTRP1( TM, TAB11, 1) +
#      f      HCCU * INTRP1( TM, XCCU, 1) +
#      f      HVESP * INTRP1( TM, TLVESP, 1) +
#      f      HCUBE * INTRP1( TM, TLCUBE, 1) +
#      f      HCUMN * INTRP1( TM, TLCUMN, 1)
#
#      ELSE
#
#      FCAB = HSST * INTGL1( TEM1, TEM2, TAB2 ) / (TEM2-TEM1) +
#      f      HBRAS * INTGL1( TEM1, TEM2, TAB10 ) / (TEM2-TEM1) +
#      f      HPTFE * INTGL1( TEM1, TEM2, TAB11 ) / (TEM2-TEM1) +
#      f      HCCU * INTGL1( TEM1, TEM2, XCCU ) / (TEM2-TEM1) +
#      f      HVESP * INTGL1( TEM1, TEM2, TLVESP ) / (TEM2-TEM1) +
#      f      HCUBE * INTGL1( TEM1, TEM2, TLCUBE ) / (TEM2-TEM1) +
#      f      HCUMN * INTGL1( TEM1, TEM2, TLCUMN ) / (TEM2-TEM1)
#
#      END IF
#
#      FCAB = FMHAR * FCAB * 1.D-6 / HL          # mm**2 --> m**2
#
#      RETURN
#      END

```

```

#   internal Harness Dissipation
#   -----
#
#   QI 4731 = X2OHM*X2L/5.  # CVV plug
#   QI 6051 = X2OHM*X2L/5.
#   QI 6052 = X2OHM*X2L/5.
#   QI 6053 = X2OHM*X2L/5.
#   QI 6054 = X2OHM*X2L/5.
#   QI 6055 = X2OHM*X2IL/5.
#   QI 6056 = X2OHM*X2IL/5.
#   QI 6057 = X2OHM*X2IL/5.
#   QI 6058 = X2OHM*X2IL/5.
#   QI 6059 = X2OHM*X2IL/5.+ 0.25*(PA3OHM*PA3L+SP3OHM*SP3L+HI3OHM*HI3L)
# this node is part of $PAYLOAD
#
#   QI 4738 = X3OHM*X3L/5.  # CVV plug
#   QI 6061 = X3OHM*X3L/5.
#   QI 6062 = X3OHM*X3L/5.
#   QI 6063 = X3OHM*X3L/5.
#   QI 6064 = X3OHM*X3L/5.
#   QI 6065 = X3OHM*X3IL/5.
#   QI 6066 = X3OHM*X3IL/5.
#   QI 6067 = X3OHM*X3IL/5.
#   QI 6068 = X3OHM*X3IL/5.
#   QI 6069 = X3OHM*X3IL/5.+ 0.25*(SP5OHM*SP5L) # this node is part of $PAYLOAD
#
#
#           Harness X2  CVV - HS1  (Instruments w/o SPIRE JFETs)
#           copied from model herschel_delivered.d from 30.11.01
#
X2SST  = 25.00D0;      # [mm^2] X-sect  SST
X2BRAS = 9.90D0;      # [mm^2] X-sect  BRASS
X2CUBE = 0.34D0;      # [mm^2] X-sect  CuBe
X2CUMN = 0.00D0;      # [mm^2] X-sect  Manganin
X2PTFE = 269.00D0;    # [mm^2] X-sect  Teflon
X2CCU  = 0.00D0;      # [mm^2] X-sect  commercial Cu
X2VESP = 0.00D0;      # [mm^2] X-sect  Vespel
X2L    = 0.35D0;      # [m]      Length
X2IL   = 1.2D0;       # [m]      Length
X2OHM  = 10.42D-3;    # [W/m]    Ohmic Heat
#
#           Harness X3  CVV - HS1  (SPIRE JFETs)
#           copied from model herschel_delivered.d from 30.11.01
#
X3SST  = 18.10D0;      # [mm^2] X-sect  SST
X3BRAS = 12.70D0;      # [mm^2] X-sect  BRASS
X3CUBE = 0.00D0;      # [mm^2] X-sect  CuBe
X3CUMN = 0.00D0;      # [mm^2] X-sect  Manganin
X3PTFE = 252.00D0;    # [mm^2] X-sect  Teflon
X3CCU  = 0.00D0;      # [mm^2] X-sect  commercial Cu
X3VESP = 0.00D0;      # [mm^2] X-sect  Vespel
X3L    = 0.5D0;       # [m]      Length
X3IL   = 1.2D0;       # [m]      Length
X3OHM  = 1.02D-3;     # [W/m]    Ohmic Heat
#
#   TABLE 2: stainless steel for cables  ( Lambda in [W/m * K] )
#           data from Mr. Becker / RR 634  (15. 03. 1983)
#
TAB2  ( 2 , 10 ) =
    0.100D0, 8.00000D-03, 0.400D0, 3.00000D-02, 1.000D0, 8.00000D-02,
    4.000D0, 3.00000D-01, 10.000D0, 7.00000D-01, 40.000D0, 5.00000D+00,
    80.000D0, 8.00000D+00, 150.000D0, 1.10000D+01, 300.000D0, 1.50000D+01,
    400.000D0, 1.50000D+01;
#

```

```
# TABLE 10: brass for cables ( Lambda in [W/m * K] )
# data from Mr. Becker / RR 634 (15. 03. 1983)
TAB10 ( 2, 9 ) =
  0.100D0, 6.00000D-02, 0.400D0, 2.00000D-01, 1.000D0, 7.00000D-01,
  4.000D0, 3.00000D+00, 10.000D0, 1.00000D+01, 40.000D0, 3.70000D+01,
  80.000D0, 6.50000D+01, 150.000D0, 8.50000D+01, 300.000D0, 1.20000D+02;
#
# TABLE 11: TEFLON for cables - insulation ( Lambda in [W/m * K] )
# data from Mr. Becker / RR 634 (15. 03. 1983)
TAB11 ( 2, 9 ) =
  0.100D0, 1.02000D-03, 0.400D0, 4.09000D-03, 1.000D0, 1.02000D-02,
  4.000D0, 4.09000D-02, 10.000D0, 9.69000D-02, 40.000D0, 1.96000D-01,
  80.000D0, 2.35000D-01, 150.000D0, 2.55000D-01, 300.000D0, 2.61500D-01;
#*****
# THERMAL CONDUCTIVITY FOR COPPER (COMMERCIAL) (W./M.K.)
# DATA FROM DOC AEROSPATIALE CA/CS/T
#*****
XCCU (2,12)=
  1.0D0, 80.0D0,
  2.0D0, 140.0D0,
  3.0D0, 200.0D0,
  4.0D0, 280.0D0,
  6.0D0, 420.0D0,
  10.0D0, 700.0D0,
  15.0D0,1000.0D0,
  30.0D0,1500.0D0,
  50.0D0, 700.0D0,
  100.0D0, 500.0D0,
  200.0D0, 410.0D0,
  300.0D0, 400.0D0;
#*****
# Lambda table for CuMn12Ni4 Manganin [W/mK]
#*****
TLCUMN (2, 8) =
  1.0D0, 0.06D0,
  4.0D0, 0.5D0,
  10.0D0, 2.0D0,
  40.0D0, 7.0D0,
  80.0D0, 13.0D0,
  150.0D0, 16.000D0,
  200.0D0, 18.000D0,
  300.0D0, 21.000D0;
#*****
# Lambda table for CuBe copper-beryllium [W/mK]
# Data delivered by T. Passvogel ( ESA-fax PT-01750 23.02.1996 )
#*****
TLCUBE (2, 7) =
  2.0D0, 0.900D0,
  3.0D0, 1.400D0,
  4.0D0, 1.900D0,
  10.0D0, 4.900D0,
  20.0D0, 11.000D0,
  80.0D0, 37.000D0,
  300.0D0, 95.000D0;
#*****
# TLVESP: Vespel/Kapton for cable insulation and supports [W/m*K]
# data from Mr. Bruce Swinyard, RAL (09. 11. 1999)
#*****
TLVESP ( 2, 9 ) =
  0.3D0, 1.6D-04, 1.0D0, 1.1D-03, 2.0D0, 2.2D-03,
  3.0D0, 3.4D-03, 4.0D0, 0.02D0, 10.0D0, 0.025D0,
  15.0D0, 0.035D0, 30.0D0, 0.15D0, 300.0D0, 0.35D0;
#
```

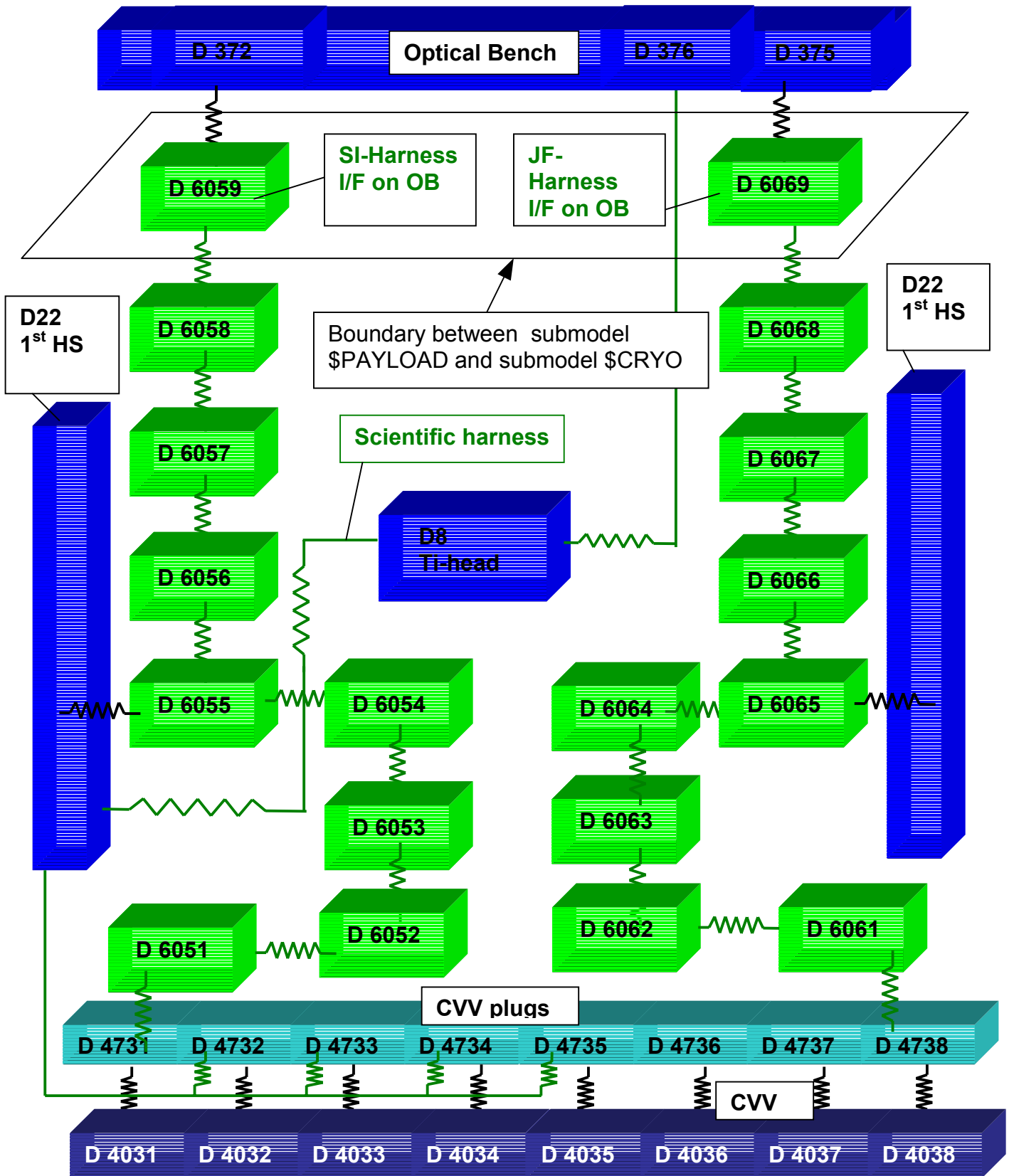

Figure 4-5: Harness interfaces between \$PAYLOAD and \$CRYO

4.2.3 Tank Suspension Thermal Modelling

The nodes identifiers and distributions along the tank suspension straps are shown in Figure 4-7. The strap design is that of ISO as defined in RD 15.

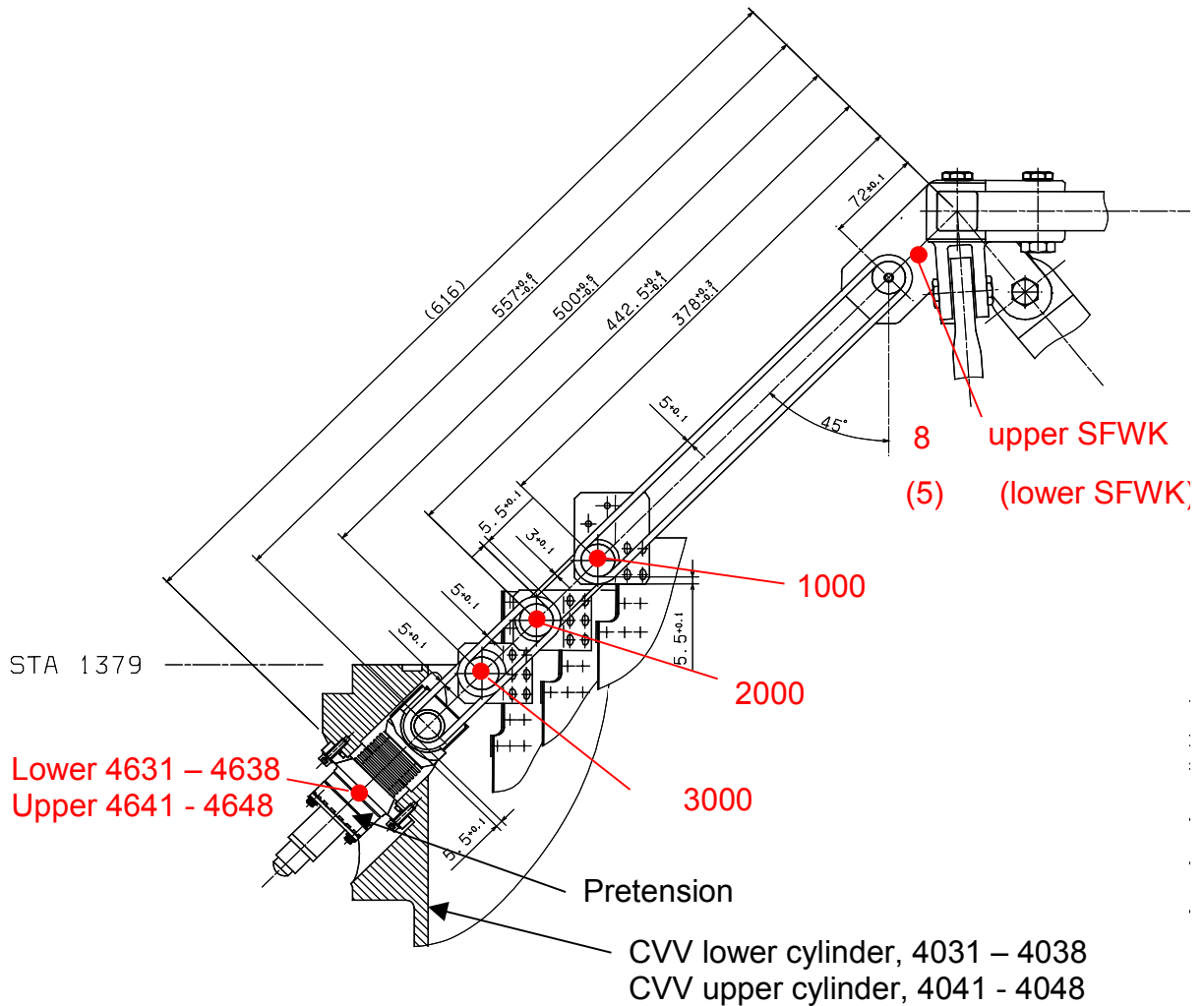

Figure 4-7: Thermal nodes distribution of tank-suspensions

4.2.4 LOU Window Thermal Modelling

The LOU-window modelization already considers the two additional alignment windows. In contrast to the HPLM-model (RD 03) 9 LOU windows instead of 7 are considered, i.e. area of node 4090 and all couplings are updated respectively. The LOU window thermal modelization is shown in Figure 4-9.

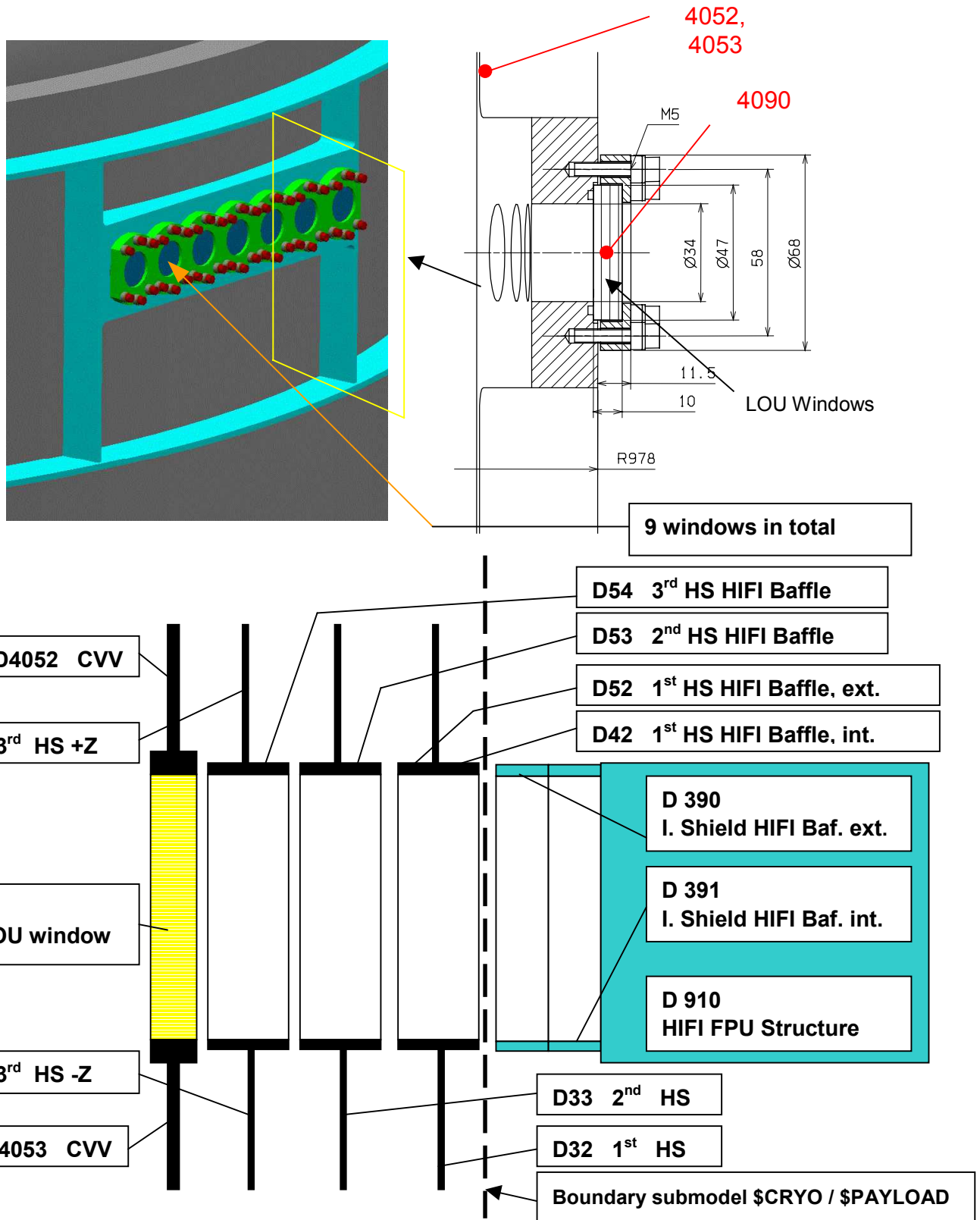

Figure 4-9: LOU window thermal nodes and interfaces

4.2.5 Particular EQM-relevant Design Details

4.2.5.1 EQM Auxiliary Tank Interfaces to HERSCHEL Spatial Framework

Between EQM-aux. Tank and Ti-heads of upper spatial framework interface (node 8) the following CFRP-straps (EUROCOPTER-design) are considered and included in the TMM:

4 CFC-straps between main tank and Ti-heads (node 8) introduced w.r.t. data provided by E.Wilz, C. Schlosser from H. Bansemir (EUROCOPTER) e-mails from 4. and 5. Feb. 2002:

4 straps of dimension 200 x 106 x 4mm:

20 layers +-45° a 0.0966 mm, V913/40/G801 with T300 fibres

10 layers 0° a 0.2177 mm, V913/40/G808 with T300 fibres

==> volume fraction of +-45° = 47.0%, of 0° fibres = 53.0%

Assumption: $k_{90^\circ} = 0.197 \text{ K}^\circ$

##

```
GL( 2, 8) = 4.D0*0.106D0*0.004109D0/0.200D0 *
          ( 0.47D0/2.D0*( 1.D0 + 0.197D0) + 0.53D0 ) * FLT300( T2, T8) ;
```

4.2.5.2 EQM Auxiliary Tank Interfaces to Instrument Level-0-Interfaces

The routing of the cooling straps between Instrument L0-interfaces and aux. Tank is not yet developed. Due to the absence of data the following PFM-strap design is considered and included in the TMM:

Cooling straps to Level 0 (high conductivity copper, Cu 99.999%)
updated according to cross-sections and lengths emerging from RD 04:

```
GL( PLM:811, 2): SPIRE           20 x 2.0 x 580 mm
GL( PLM:819, 2): SPIRE           20 x 2.0 x 620 mm
GL( PLM:820, 2): SPIRE           20 x 2.0 x 680 mm
GL( PLM:765, 2): PACS Blue detector 20 x 0.5 x 384 mm
GL( PLM:760, 2): PACS Red detector  20 x 2.0 x 319 mm
GL( PLM:781, 2): PACS Sorption Cooler 20 x 1.0 x 383 mm
GL( PLM:912, 2): HIFI           20 x 1.5 x 400 mm
```

Considering an "ISO-standard interface" contact conductance of 0.4 W/K at both sides of the strap results in the following definitions of thermal couplings:

```
#
GL( PLM:811, 2) = 1./ ( 2./0.4 + 1./ (40.0D-6/0.580D0 * INTRP1 (.5*(T:PLM:811+T2), TLCU, 1) ) )
GL( PLM:819, 2) = 1./ ( 2./0.4 + 1./ (40.0D-6/0.620D0 * INTRP1 (.5*(T:PLM:819+T2), TLCU, 1) ) )
GL( PLM:820, 2) = 1./ ( 2./0.4 + 1./ (40.0D-6/0.680D0 * INTRP1 (.5*(T:PLM:820+T2), TLCU, 1) ) )
GL( PLM:765, 2) = 1./ ( 2./0.4 + 1./ (10.0D-6/0.384D0 * INTRP1 (.5*(T:PLM:765+T2), TLCU, 1) ) )
GL( PLM:760, 2) = 1./ ( 2./0.4 + 1./ (40.0D-6/0.319D0 * INTRP1 (.5*(T:PLM:760+T2), TLCU, 1) ) )
GL( PLM:781, 2) = 1./ ( 2./0.4 + 1./ (20.0D-6/0.383D0 * INTRP1 (.5*(T:PLM:781+T2), TLCU, 1) ) )
GL( PLM:912, 2) = 1./ ( 2./0.4 + 1./ (30.0D-6/0.400D0 * INTRP1 (.5*(T:PLM:912+T2), TLCU, 1) ) )
#
```

The current PFM-Design applies rigid high-purity aluminium bars as illustrated in Figure 4-11 with a flexible link to the instrument L0-interfaces. The flexible links can be designed as packages of high-purity aluminium foils connected at their flange-ends by welding. This design has to be adapted to the EQM Auxiliary Tank by modification of the aluminium bar design and by adequate mechanical

interfaces on the EQM Auxiliary Tank. Anyway the thermal performance of the rigid bar/flexible link design including all contact resistances shall show at least the same thermal performance as the copper strap design assumed in the thermal analysis. This can be achieved by adequate dimensioning of the cross sections, flange contact areas and selecting high purity aluminium 99.9995% (A5N) with a residual resistivity ratio of at least 300. This material is commercially available as bars billets or ingots of adequate size, and as foils.

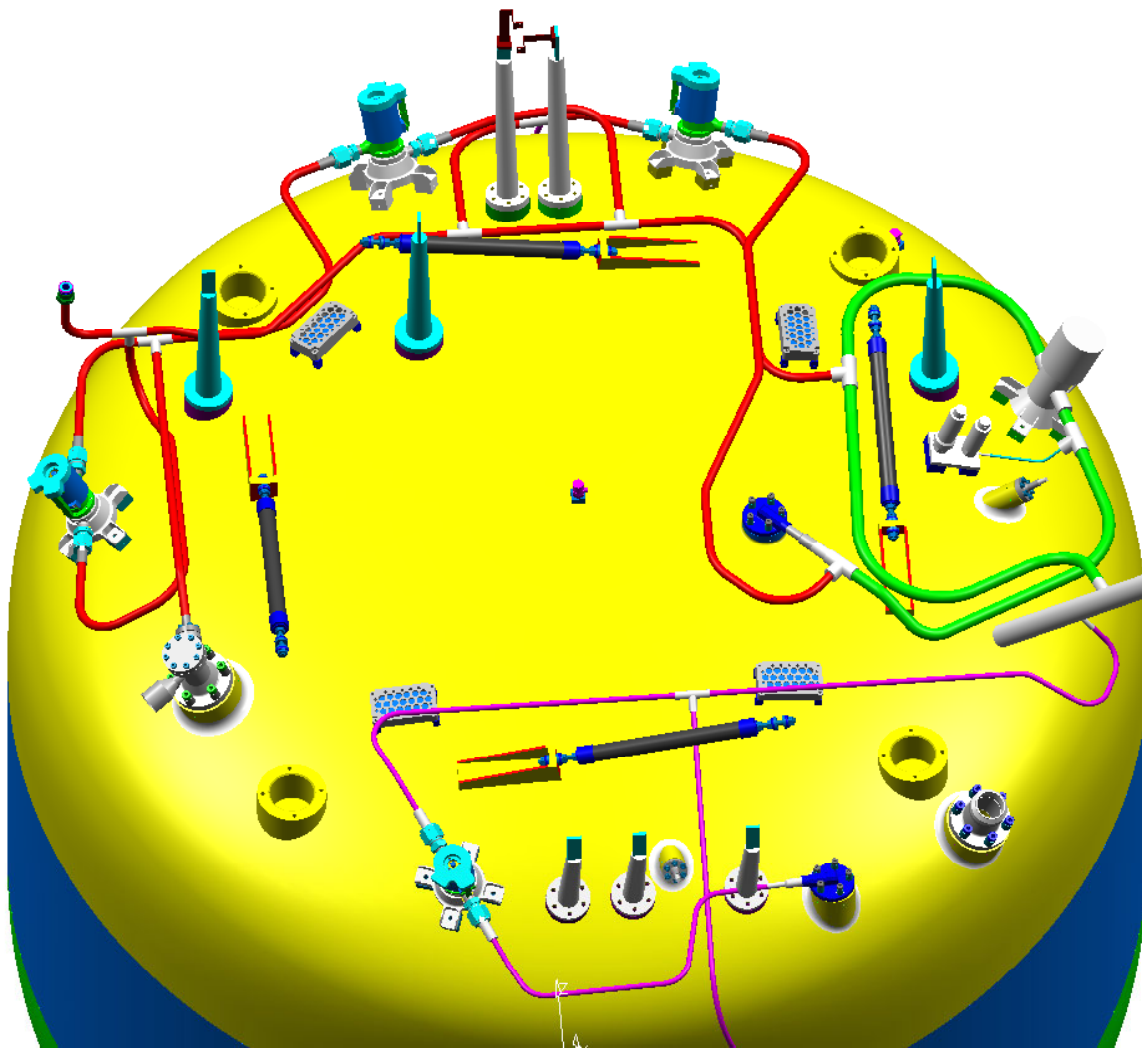

Figure 4-11: PFM rigid bar L0-link design

4.3 Submodel "VENT"

The submodel "VENT" is based on the ESATAN-submodel "V0300.esat" (see RD 17) developed for the ISO-satellite. Some adaptations had to be performed in order to use it for the heat exchange calculation within the main tank ventline of the modified ISO-cryostat. The thermal modelling technique of the ventline is shown in Figure 4-12. The various fluid couplings are computed according to the original ESATAN-program code listed below:

```
GF( 251, 201) = MFLO1 * CPHEC * (1.D0 - EFOSS );           # inlet to wall
GF( 251, 252) = MFLO1 * CPHEC * EFOSS;                   # inlet to outlet
GF( 201, 252) = GF( 251, 201);                           # wall to outlet

TMOSS = (T251+T252) / 2.0D0                               # average gas temperature within
                                                         pipe section

EFOSS = EFAC( MFLO1 , 0.012D0, LOSS , 0.352D0 , TMOSS , T201)
```

```

*****
      DOUBLE PRECISION FUNCTION EFAC( MASS, D, LENGT, RAD, TM, TWALL )
                                          # Version 3.00
*****
# Version 2.00      27. 09. 1989      M. Sander      MBB
#
#   - Subroutines block:
#     -- Changes according to KT224-27/89 (Dr. Elsner)
#        dated 21. 08. 1989:
#        Functions E,EH: Nusselt expressions
# Version 2.09      12. 03. 1992      M. Sander      MBB / KT224
#
#   - Function subroutine E expanded to zero length of
#     heat exchanger (for effective switch off)
# Version 3.00      24. 02. 1994      M. Sander      DASA / RTT222
#
#   - Recoded for ESATAN 4.5 up.
#
# -----
#           THIS FUNCTION CALCULATES THE EXPONENTIAL FACTOR FOR THE DIFFERENT
#           PIPE PARTS
# -----
# MASS      kg/s      : MASS FLOW RATE
# D          m        : PIPE DIAMETER
# LENGT     m        : LENGTH OF THE PIPE
# RAD       m        : BEND RADIUS OF PIPE
# TM        K        : AVERAGE TEMPERATURE OF HELIUM
# TWALL     K        : WALL TEMPERATURE
#
# CPHEC     J/kg*K    : SPECIFIC HEAT OF HELIUM           # CONSTANTS
# ETA       kg/(m*s)  : DYNAMIC VISCOSITY OF HELIUM
# ETAW      kg/(m*s)  : DYNAMIC VISCOSITY OF HELIUM AT TWALL
# LAM       W/m*K     : THERMAL CONDUCTIVITY OF HELIUM (interpolated)
# LAMW      W/m*K     : THERMAL CONDUCTIVITY OF HELIUM (interpolated at TWALL)
# NU        -        : NUSSELT-NUMBER
# RE        -        : REYNOLDS-NUMBER
# REK       -        : CRITICAL REYNOLDS-NUMBER
# PR        -        : PRANDTL-NUMBER
# PRW       -        : PRANDTL-NUMBER AT TWALL
# -----
#2345678 1 2345678 2 2345678 3 2345678 4 2345678 5 2345678 6 2345678 7 2
# D E F I N I T I O N S
#   DOUBLE PRECISION MASS, D, LENGT, RAD, TM
#   DOUBLE PRECISION ETA, LAM, NU, RE, REK, PR, PI, XI
#   DOUBLE PRECISION TWALL, ETAW, LAMW, PRW, HELP
#
#   PI = 3.141593D0
#
# Version 2.09      12. 03. 1992      M. Sander      MBB / KT224
#
#   - Function subroutine E expanded to zero length of
#     heat exchanger (for effective switch off)
# -----
# TERMINATION IF LENGT EQUALS ZERO                                     Version 2.09
#
#   IF (LENGT .LT. 1.D-10) THEN
#     EFAC = 1.D0
#     GO TO 99999 # ---> EXIT
#   END IF
# -----
# CALCULATION OF EQUATION PARAMETERS
# VISCOSITY, RE-NUMBER AND CRITICAL RE-NUMBER
#   ETA = INTRP1 ( TM, ETAHE, 1 ) * 1.0D-07 # [kg/m*s]
#   ETAW = INTRP1 ( TWALL, ETAHE, 1 ) * 1.0D-07 # [kg/m*s]
#   RE = 4.0D0*MASS/PI/D/ETA
#   IF ( RAD .NE. .0D0 )
# @   REK = 2320.D0*(1.D0+8.6D0*(D/2.D0/RAD)**0.45D0) # REK FOR BEND PIPE

```

```

# LAMBDA

      LAM = INTRP1 ( TM,      LAMHE1, 1 )
      LAMW = INTRP1 ( TWALL, LAMHE1, 1 )

# PRANDTL-NUMBER
      PR  = ETA * CPHEC / LAM
      PRW = ETAW * CPHEC / LAMW

# NUSSELT-NUMBER ACCORDING TO LINDE PROPOSAL (Changes acc. Dr. Elsner)
      IF ( RAD .EQ. 0.0D0 ) THEN                # --> STRAIGHT PIPE
        IF ( RE .LE. 2320.D0 ) THEN            # LAMINAR FLOW
          NU = 3.66D0 + 0.0677D0 * ( PR * RE * D/LENGT )**1.33D0
          * / ( 1.D0 + 0.1D0 * PR * (RE*D/LENGT)**0.83D0 )
        ELSE                                     # TURBULENT FLOW
          XI = (1.82D0*LOG10(RE)-1.64D0)**(-2.D0)
          NU = XI/8.D0 * (RE-1000.D0)
          @ * PR * ( 1.D0+ (D/LENGT)**(2.D0/3.D0) )
          @ /
          @ (1.D0 + 12.7D0 *
          @ (XI/8.D0)**0.5D0 * (PR**(2.D0/3.D0) -1.D0) )

          END IF                                # LAMINAR/TURBULENT
        ELSE                                     # --> BEND PIPE
          IF (RE .LT. REK) THEN                 # LAMINAR FLOW
            HELP = 0.5D0 + 0.2903D0 * (D*0.5D0/RAD)**0.194D0
            NU = 3.66D0 +
            @ 0.08D0 * ( 1.D0 + 0.8D0 * (D*0.5D0/RAD)**0.9D0 ) *
            @ RE**HELP * PR**0.333D0 * (PR/PRW)**0.14D0

          ELSE                                     # TURBULENT FLOW

            XI = 0.3164D0 / RE**0.25D0 + 0.03D0 * SQRT(D*0.5D0/RAD)
            NU = 0.125D0 * XI * RE * PR * (PR/PRW)**14
            @ /
            @ ( 1.D0 + 12.7D0*SQRT(0.125D0*XI) * (PR**0.6666D0 - 1.D0) )

          END IF                                # LAMINAR/TURBULENT
        END IF                                # STRAIGHT/BENDEDE

# -----
# TERMINATION IF THERE IS NO MASS FLOW
      IF (MASS .LT. 1.D-10) THEN
        EFAC = .0D0
        GO TO 99999                               # ---> EXIT
      END IF
# -----
# CALCULATION OF THE EXPONENTIAL FACTOR
      EFAC = NU*LAM*PI*LENGT / (CPHEC*MASS)
      IF (EFAC .GT. 15.D0) THEN
        EFAC = .0D0
      ELSE IF (EFAC .EQ. .0D0) THEN
        EFAC = 1.D0
      ELSE
        EFAC = EXP(-EFAC)
      END IF

99999 CONTINUE
      RETURN
      END
#

```

```

*****
#* THERMAL CONDUCTIVITY OF HELIUM GAS [W/m*K] : --> 100 mbar = 10000 Pa <-- *
#* REFERENCE: NBS TN 631 (Thermophysical properties of Helium4 ... ) *
#*****
LAMHE1( 2 , 47 ) =
  0.2D0, 0.25D-3, 0.4D0, 1.23D-3, 0.6D0, 2.33D-3,
  0.8D0, 2.64D-3, 1.0D0, 2.69D-3, 1.2D0, 2.79D-3,
  1.4D0, 2.96D-3, 1.6D0, 3.20D-3, 1.8D0, 3.48D-3,
  2.0D0, 3.82D-3, 2.4D0, 4.59D-3, 2.8D0, 5.45D-3,
  3.2D0, 6.34D-3, 3.6D0, 7.24D-3, 4.0D0, 8.11D-3,
  4.5D0, 9.15D-3, 5.0D0, 10.11D-3, 5.5D0, 11.01D-3,
  6.0D0, 11.84D-3, 7.0D0, 13.37D-3, 8.0D0, 14.77D-3,
  9.0D0, 16.07D-3, 10.0D0, 17.30D-3, 12.0D0, 19.59D-3,
  14.0D0, 21.73D-3, 16.0D0, 23.74D-3, 20.0D0, 27.49D-3,
  25.0D0, 31.78D-3, 30.0D0, 35.74D-3, 35.0D0, 39.47D-3,
  40.0D0, 43.00D-3, 50.0D0, 49.59D-3, 60.0D0, 55.72D-3,
  70.0D0, 61.50D-3, 80.0D0, 66.99D-3, 100.0D0, 77.29D-3,
  120.0D0, 86.90D-3, 140.0D0, 95.97D-3, 160.0D0, 104.59D-3,
  180.0D0, 112.83D-3, 200.0D0, 120.76D-3, 225.0D0, 130.28D-3,
  250.0D0, 139.44D-3, 275.0D0, 148.28D-3, 300.0D0, 156.84D-3,
  350.0D0, 172.00D-3, 400.0D0, 189.00D-3;
#
#*****
#* THERMAL CONDUCTIVITY OF HELIUM GAS [W/m*K] : --> 1.0 bar = 100000 Pa <-- *
#* REFERENCE: NBS TN 631 (Thermophysical properties of Helium4 ... ) *
#*****
LAMHE2(2,20) =
  0.00D0,1.0D-6, 4.50D0,0.0106D0,
  5.00D0,0.0111D0, 5.50D0,0.0118D0,
  6.00D0,0.0125D0, 7.00D0,0.0138D0,
  8.00D0,0.0151D0, 10.00D0,0.0175D0,
  15.00D0,0.0225D0, 20.00D0,0.0267D0,
  25.00D0,0.0306D0, 30.00D0,0.0341D0,
  40.00D0,0.0407D0, 50.00D0,0.0468D0,
  75.00D0,0.0607D0, 100.00D0,0.0736D0,
  150.00D0,0.0969D0, 200.00D0,0.1180D0,
  300.00D0,0.1550D0, 400.00D0,0.1890D0;
#
# Version 2.05 27. 04. 1990 M. Sander MBB / KT224
# - Table ETAHE changed: peak at 5.1 K removed
#*****
#* DYNAMIC VISCOSITY OF HELIUM GAS [10**7 KG/M*S] : -> 100 mbar = 10000 Pa *
#* REFERENCE: NBS TN 631 (Thermophysical properties of Helium4 ... ) *
#*****
ETAHE (2,39)=
  0.00D0, 1.D-6, 1.50D0, 3.00D0,
  2.50D0, 6.38D0, 3.00D0, 7.80D0,
  4.00D0, 10.30D0, 5.00D0, 12.60D0,
  5.10D0, 12.83D0, # linear interpolated old: 25.20,
  5.20D0, 13.07D0, # linear interpolated old: 22.30,
  5.30D0, 13.30D0, 5.50D0, 13.70D0,
  6.00D0, 14.70D0, 7.00D0, 16.70D0,
  8.00D0, 18.50D0, 9.00D0, 20.20D0,
  10.00D0, 21.90D0, 12.00D0, 25.00D0,
  14.00D0, 27.90D0, 16.00D0, 30.50D0,
  18.00D0, 33.10D0, 20.00D0, 35.50D0,
  25.00D0, 41.00D0, 30.00D0, 46.10D0,
  40.00D0, 55.20D0, 50.00D0, 63.40D0,
  60.00D0, 71.00D0, 70.00D0, 78.10D0,
  80.00D0, 84.90D0, 90.00D0, 91.40D0,
  100.00D0, 97.70D0, 125.00D0,111.00D0,
  150.00D0,125.00D0, 175.00D0,138.00D0,
  200.00D0,151.00D0, 225.00D0,164.00D0,
  250.00D0,176.00D0, 275.00D0,188.00D0,
  300.00D0,199.00D0, 350.00D0,222.00D0,
  400.00D0,243.00D0;
#

```

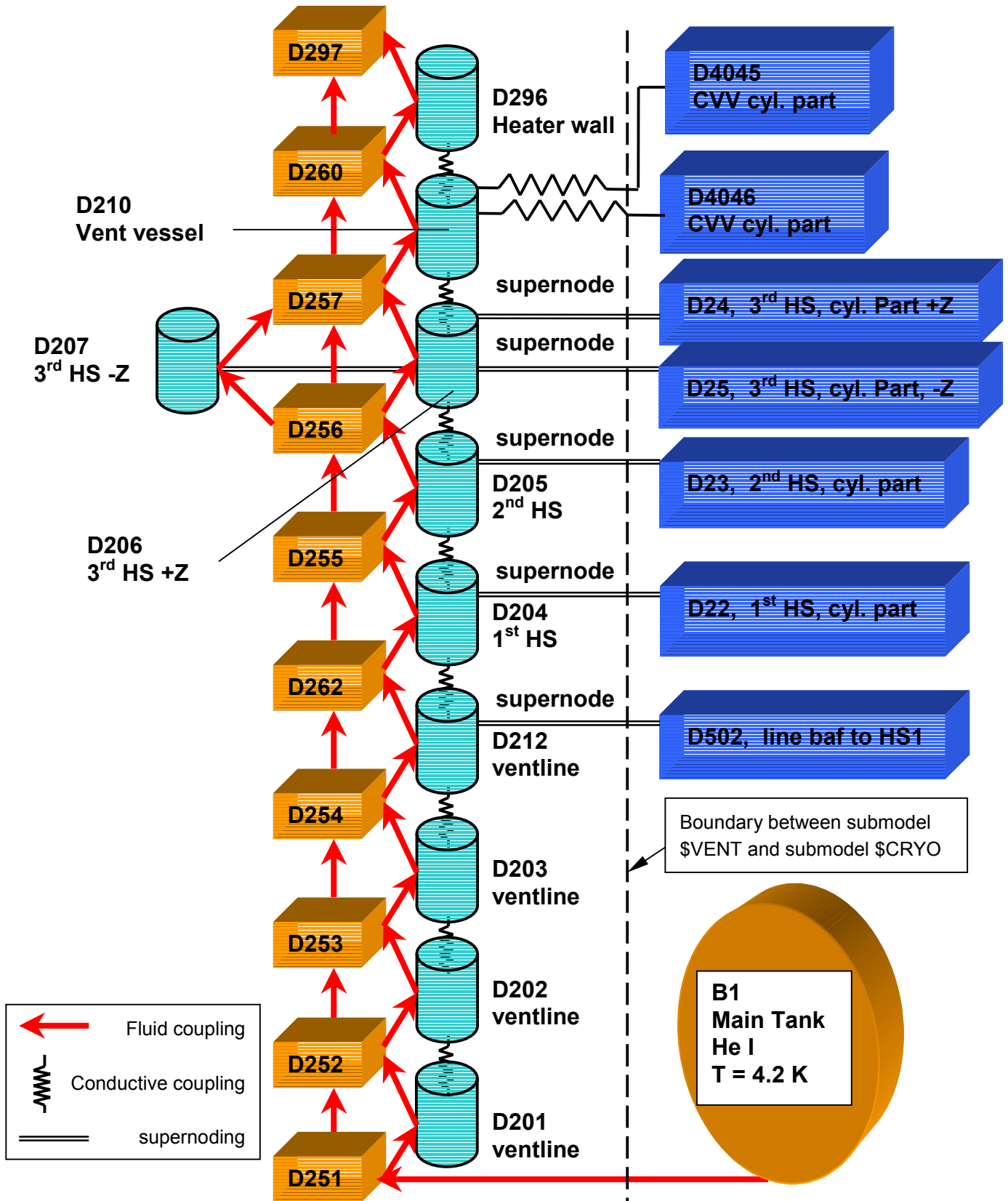

Figure 4-12: Thermal nodes and thermal network of submodel \$VENT (main tank ventline) with interfaces to submodel \$CRYO

4.4 Submodel “PAYLOAD”

4.4.1 General PAYLOAD-TMM Description

The submodel “PAYLOAD” comprises of the HERSCHEL OB with the instruments, the instrument shield and shield MLI. The thermal node identifiers and thermal node definitions are shown in Figure 4-14. The submodel “PAYLOAD” is identical to the relevant part in the HPLM TMM (see RD 03) with the exception that the L0-cooling straps from the instrument L0-interfaces to the tank interfaces reflect the latest requirements of the instrument SPIRE (see AD 03) and §3.3. The resulting strap dimensions are defined in § 4.2.5.

Note: In Figure 4-14 the L0-cooling straps are schematically connecting the instrument L0-interfaces with the auxiliary tank. In reality the auxiliary tank is smaller than the OB. Therefore the EQM-straps have to be tailored in order to achieve flight-representative temperatures at the instrument L0-interfaces.

Level-0-interfaces: #765, #760, #781, #811, #820, #819, # 912

Level-1-interfaces: not depicted in Fig. 4-7

Level 2-interfaces: OB-thermal nodes (#371 thru # 381)

The geometrical-mathematical model in ESARAD-format in order to compute the radiative heat exchange within the instrument/test-adapter-cavity is shown in Figure 4-16 thru Figure 4-18.

The thermal node distributions as illustrated in Figure 4-20 thru Figure 4-24 within the instruments are compliant to RD 14 and identical to those used in the HPLM TMM (see RD 03).

The instrument dissipations underlying all analysis in this report are the in-orbit averages incl. 20 % uncertainty as defined in RD 14. They are compiled in Table 4-1.

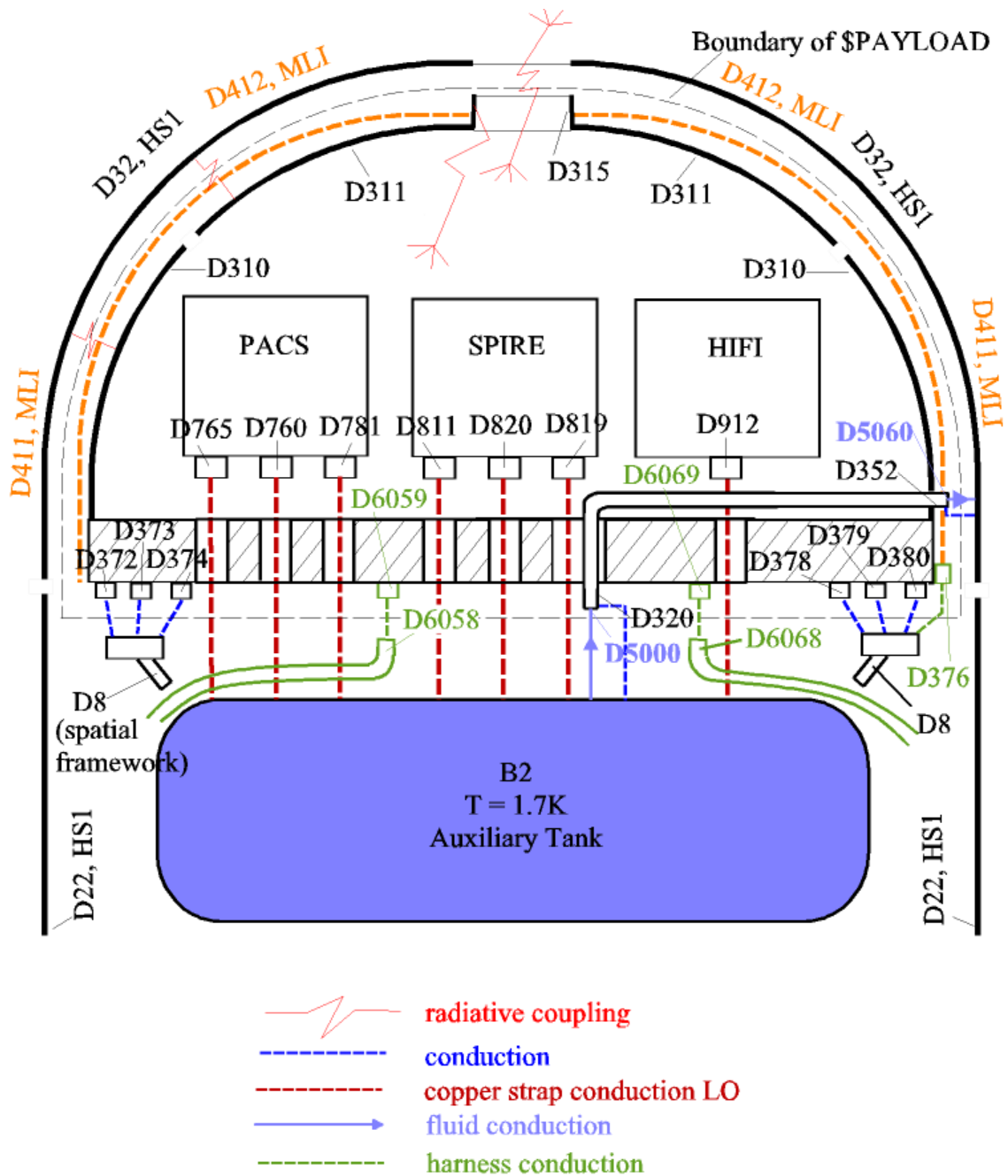

Figure 4-14: Thermal nodes distribution of HERSCHEL-PL TMM \$PAYLOAD with interfaces to TMM \$CRYO

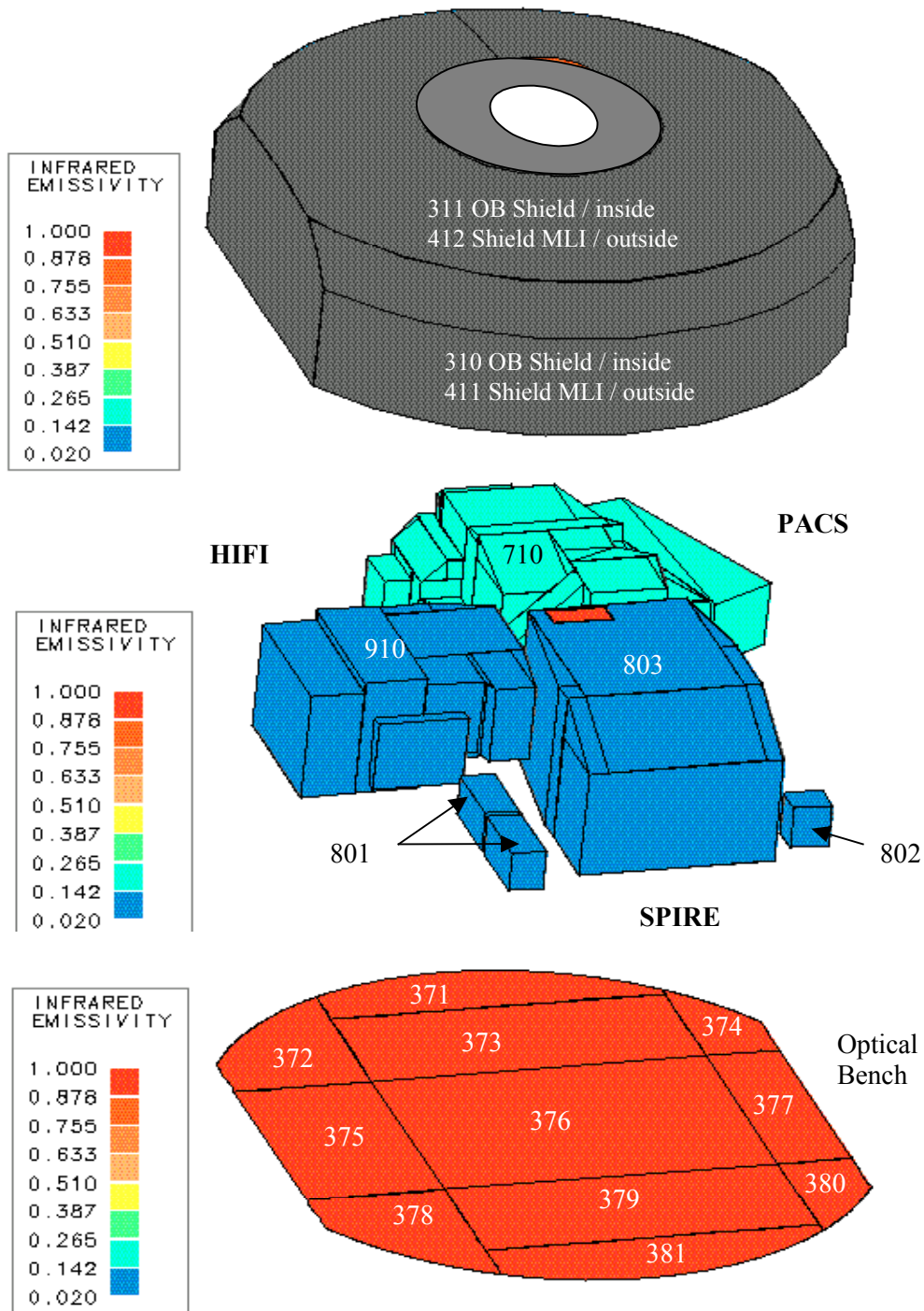

Figure 4-16: Nodal distribution of ESARAD model of HERSCHEL payload

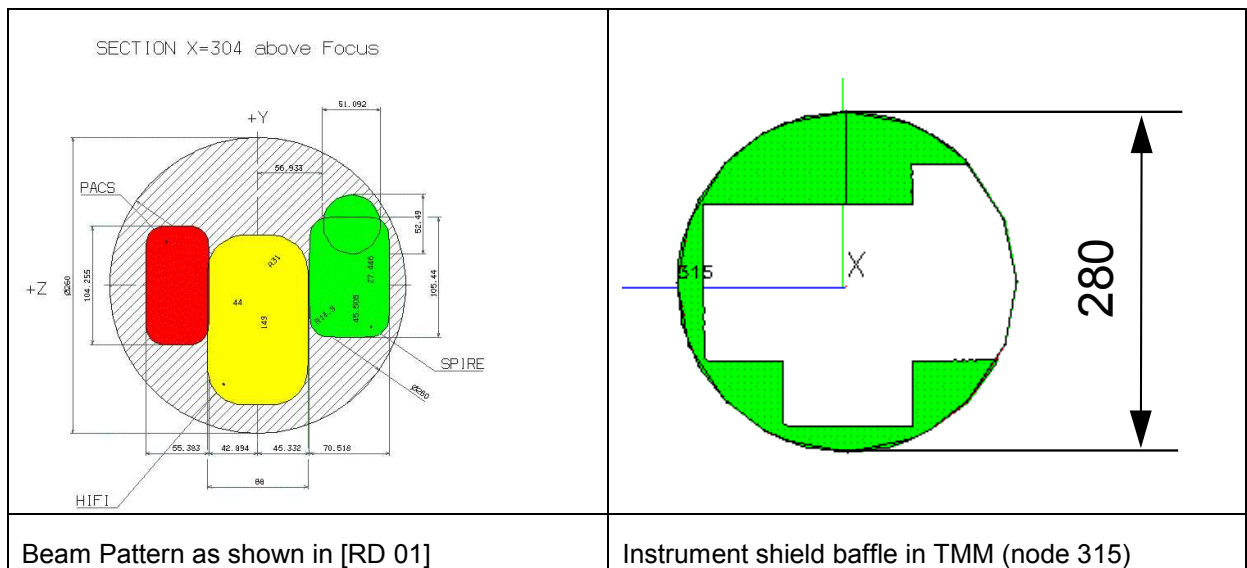

Figure 4-18: Beam Pattern for the three Instruments

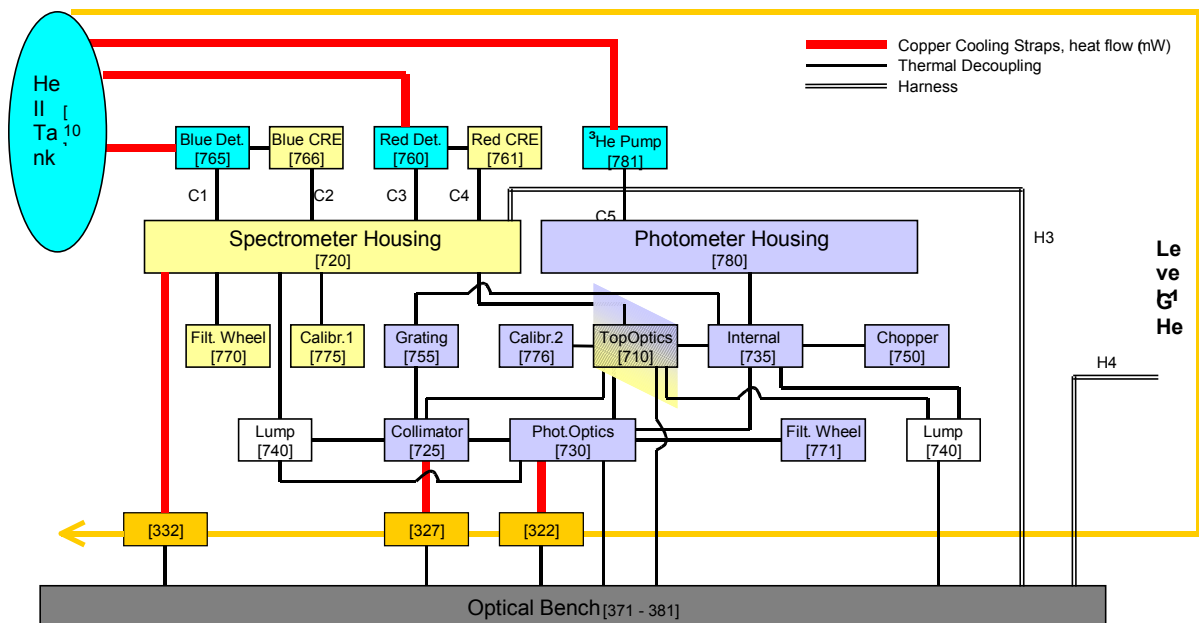

Figure 4-20: Thermal nodes distribution of instrument "PACS"

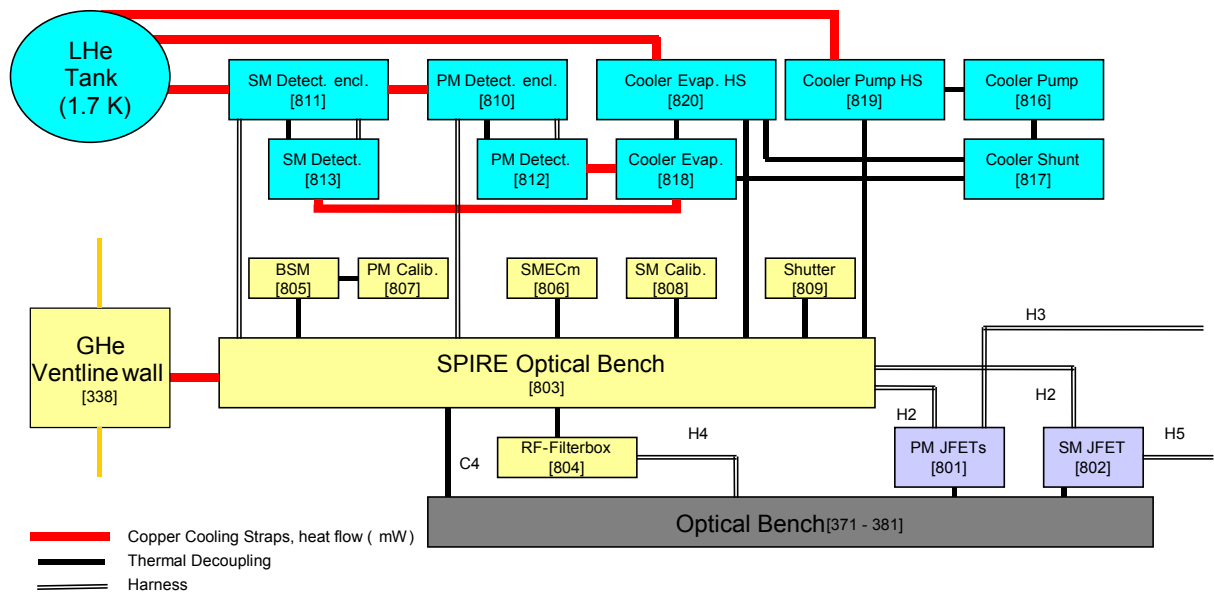

Figure 4-22: Thermal nodes distribution of instrument "SPIRE"

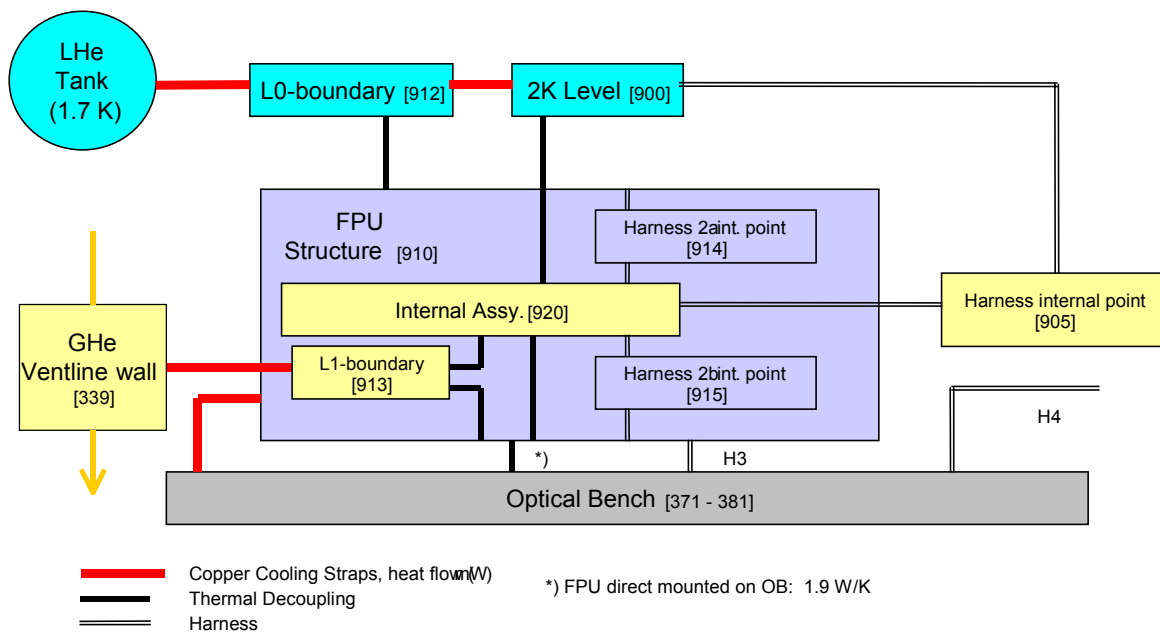

Figure 4-24: Thermal nodes distribution of instrument "HIFI"

```

# Instrument Dissipation
#-----
#
# Average Power dissipation for Steady State
#
# PACS
#
    QI750 = 2.00E-03 * 1.2 / 6.0           # Chopper
    QI755 = 5.00E-03 * 1.2 / 6.0           # Grating
    QI761 = 1.50E-03 * 1.2 / 6.0           # Red Detector CRE
    QI765 = 0.80E-03      / 6.0           # Blue Detector Heater
    QI766 = 1.50E-03 * 1.2 / 6.0           # Blue Detector CRE
    QI770 = 0.03E-03 * 1.2                 # Filter Wheel 1
    QI771 = 0.03E-03 * 1.2                 # Filter Wheel 2
    QI775 = 0.80E-03 * 1.2 / 3.0           # Black Body 1
    QI776 = 0.80E-03 * 1.2 / 3.0           # Black Body 2
    QI781 = (6.0E-03 + 0.41E-3) * 1.2/6.0 + 758.0*1.2 / (46.*60.*60.)/6.
                                           # Photometer Buffer

#
    QI720= 0.75*PA3OHM*PA3L

#
# SPIRE
#
    QI801 = 1.2 * 49.000D-3 /6.0 + 0.75*SP5OHM*SP5L   # PM JFET
    QI802 = 1.2 * 14.1D-3 /6.0                         # SM JFET
    QI805 = 1.2 * 5.0D-3 /6.0                           # BSM
    QI806 = 1.2 * 2.4D-3 /6.0                           # SMECM
    QI807 = 1.2 * 0.1D-3 /6.0                           # PM cal
    QI808 = 1.2 * 2.0D-3 /6.0                           # SM cal
    QI816 = 758.0 * 1.2 / (46.*60.*60.)/3.             # Pump
    QI817 = 1.2 * 0.01D-3 /6.0                          # Shunt
    QI819 = 1.2 * 0.4D-3 /6.0                          # Pump HS

#
    QI804= 0.75*SP3OHM*SP3L

#
# HIFI
#
# HIFI dissipation data is upgraded according to document FPSS-0166, 21 sept. 2001
# JDa 24/09/2001
    QI900 = k_diss*0.34D-3                               # HIFI (2 K)
    QI905 = k_diss*0.89D-3                               # HIFI Ohmic harness 1 dissip.
    QI910 = k_diss*39.08D-3 + 0.75*HI3OHM*HI3L          # HIFI (FPU)
    QI914 = k_diss*0.89D-3                               # HIFI Ohmic harness 2a dissip.
    QI915 = k_diss*0.0D-3                               # HIFI Ohmic harness 2b dissip.
    QI920 = k_diss*0.0D-3                               # HIFI (Level 1)

#
k_diss = 0.333333*1.2;

```

Table 4-1: Average dissipations of instruments (from RD 14)

4.4.2 OB-Ventline Modelling

A different but thermally equivalent ventline modelling technique compared to the ISO-cryostat (see § 4.3) is used for the OB-ventline applying a different but similar heat transfer equation ($Nu = f(Re, Pr)$). It is identical to that used in the HPLM (see RD 03). The thermal network of the OB-ventline is illustrated in Figure 4-26. The original ESATAN program code is listed below:

```
# Conduction in ventline wall: cross-section / pipe-section-length * conductivity
# of alu
#
GL(320, 321) = 39.6D-6/0.425D0*INTRP1(.5*(T320+T321),TAB8,1); #
GL(321, 322) = 39.6D-6/0.035D0*INTRP1(.5*(T321+T322),TAB8,1); #
GL(322, 323) = 39.6D-6/0.035D0*INTRP1(.5*(T322+T323),TAB8,1); #
GL(323, 324) = 39.6D-6/0.135D0*INTRP1(.5*(T323+T324),TAB8,1); #
GL(324, 325) = 39.6D-6/0.610D0*INTRP1(.5*(T324+T325),TAB8,1); #
GL(325, 326) = 39.6D-6/0.525D0*INTRP1(.5*(T325+T326),TAB8,1); #
GL(326, 327) = 39.6D-6/0.035D0*INTRP1(.5*(T326+T327),TAB8,1); #
GL(327, 328) = 39.6D-6/0.035D0*INTRP1(.5*(T327+T328),TAB8,1); #
GL(328, 329) = 39.6D-6/0.195D0*INTRP1(.5*(T328+T329),TAB8,1); #
GL(329, 330) = 39.6D-6/0.240D0*INTRP1(.5*(T329+T330),TAB8,1); #
GL(330, 331) = 39.6D-6/0.095D0*INTRP1(.5*(T330+T331),TAB8,1); #
GL(331, 332) = 39.6D-6/0.035D0*INTRP1(.5*(T331+T332),TAB8,1); #
GL(332, 333) = 39.6D-6/0.035D0*INTRP1(.5*(T332+T333),TAB8,1); #
GL(333, 334) = 39.6D-6/0.180D0*INTRP1(.5*(T333+T334),TAB8,1); #
GL(334, 335) = 39.6D-6/0.360D0*INTRP1(.5*(T334+T335),TAB8,1); #
GL(335, 336) = 39.6D-6/0.410D0*INTRP1(.5*(T335+T336),TAB8,1); #
GL(336, 337) = 39.6D-6/0.230D0*INTRP1(.5*(T336+T337),TAB8,1); #
GL(337, 338) = 39.6D-6/0.035D0*INTRP1(.5*(T337+T338),TAB8,1); #
GL(338, 339) = 39.6D-6/0.035D0*INTRP1(.5*(T338+T339),TAB8,1); #
GL(339, 340) = 39.6D-6/0.230D0*INTRP1(.5*(T339+T340),TAB8,1); #
GL(340, 341) = 39.6D-6/0.460D0*INTRP1(.5*(T340+T341),TAB8,1); #
GL(341, 342) = 39.6D-6/0.560D0*INTRP1(.5*(T341+T342),TAB8,1); #
GL(342, 343) = 39.6D-6/0.330D0*INTRP1(.5*(T342+T343),TAB8,1); #
GL(343, 344) = 39.6D-6/0.035D0*INTRP1(.5*(T343+T344),TAB8,1); #
GL(344, 345) = 39.6D-6/0.035D0*INTRP1(.5*(T344+T345),TAB8,1); #
GL(345, 346) = 39.6D-6/0.250D0*INTRP1(.5*(T345+T346),TAB8,1); #
GL(346, 347) = 39.6D-6/0.700D0*INTRP1(.5*(T346+T347),TAB8,1); #
GL(347, 348) = 39.6D-6/0.660D0*INTRP1(.5*(T347+T348),TAB8,1); #
GL(348, 349) = 39.6D-6/0.475D0*INTRP1(.5*(T348+T349),TAB8,1); #
GL(349, 350) = 39.6D-6/0.460D0*INTRP1(.5*(T349+T350),TAB8,1); #
GL(350, 351) = 39.6D-6/0.670D0*INTRP1(.5*(T350+T351),TAB8,1); #
GL(351, 352) = 39.6D-6/0.755D0*INTRP1(.5*(T351+T352),TAB8,1); #
#
#*****
# TABLE 8: AL LIKE 6061 SHIELDS BAFFLE ( Lambda in [W/m * K] )
#*****
#
# - New values for table 8 (AL 6061) according to
# Fax SE/SP/IS 2813/88 by A. Rocaboy, dated 31. 05. 1988
# "resultats des mesures de conductivite thermique
# du 6061 etat T651"
#
TAB8 ( 2 , 8 ) =
5.7D0, 10.3D0, 11.5D0, 21.9D0, 21.0D0, 41.7D0,
36.0D0, 68.8D0, 78.0D0, 108.0D0, 156.0D0, 134.0D0,
296.0D0, 174.0D0, 400.0D0, 174.0D0;
#
```

```

# -----
#
#                               FLUID Conductances
# -----
#
#   Optical Bench:  GHe Ventline Level 1
#
GF( 5000, 5010 ) = MFLO2 * CPHEC;      # inlet --> outlet of wall pipe node #320
GF( 5010, 5011 ) = MFLO2 * CPHEC;      # inlet --> outlet of wall pipe node #321
GF( 5011, 5012 ) = MFLO2 * CPHEC;      # inlet --> outlet of wall pipe node #322
GF( 5012, 5013 ) = MFLO2 * CPHEC;      # inlet --> outlet of wall pipe node #323
GF( 5013, 5014 ) = MFLO2 * CPHEC;      # inlet --> outlet of wall pipe node #324
GF( 5014, 5020 ) = MFLO2 * CPHEC;      # inlet --> outlet of wall pipe node #325
GF( 5020, 5021 ) = MFLO2 * CPHEC;      # inlet --> outlet of wall pipe node #326
GF( 5021, 5022 ) = MFLO2 * CPHEC;      # inlet --> outlet of wall pipe node #327
GF( 5022, 5023 ) = MFLO2 * CPHEC;      # inlet --> outlet of wall pipe node #328
GF( 5023, 5024 ) = MFLO2 * CPHEC;      # inlet --> outlet of wall pipe node #329
GF( 5024, 5030 ) = MFLO2 * CPHEC;      # inlet --> outlet of wall pipe node #330
GF( 5030, 5031 ) = MFLO2 * CPHEC;      # inlet --> outlet of wall pipe node #331
GF( 5031, 5032 ) = MFLO2 * CPHEC;      # inlet --> outlet of wall pipe node #332
GF( 5032, 5033 ) = MFLO2 * CPHEC;      # inlet --> outlet of wall pipe node #333
GF( 5033, 5034 ) = MFLO2 * CPHEC;      # inlet --> outlet of wall pipe node #334
GF( 5034, 5035 ) = MFLO2 * CPHEC;      # inlet --> outlet of wall pipe node #335
GF( 5035, 5040 ) = MFLO2 * CPHEC;      # inlet --> outlet of wall pipe node #336
GF( 5040, 5041 ) = MFLO2 * CPHEC;      # inlet --> outlet of wall pipe node #337
GF( 5041, 5042 ) = MFLO2 * CPHEC;      # inlet --> outlet of wall pipe node #338
GF( 5042, 5043 ) = MFLO2 * CPHEC;      # inlet --> outlet of wall pipe node #339
GF( 5043, 5044 ) = MFLO2 * CPHEC;      # inlet --> outlet of wall pipe node #340
GF( 5044, 5045 ) = MFLO2 * CPHEC;      # inlet --> outlet of wall pipe node #341
GF( 5045, 5050 ) = MFLO2 * CPHEC;      # inlet --> outlet of wall pipe node #342
GF( 5050, 5051 ) = MFLO2 * CPHEC;      # inlet --> outlet of wall pipe node #343
GF( 5051, 5052 ) = MFLO2 * CPHEC;      # inlet --> outlet of wall pipe node #344
GF( 5052, 5053 ) = MFLO2 * CPHEC;      # inlet --> outlet of wall pipe node #345
GF( 5053, 5054 ) = MFLO2 * CPHEC;      # inlet --> outlet of wall pipe node #346
GF( 5054, 5055 ) = MFLO2 * CPHEC;      # inlet --> outlet of wall pipe node #347
GF( 5055, 5056 ) = MFLO2 * CPHEC;      # inlet --> outlet of wall pipe node #348
GF( 5056, 5057 ) = MFLO2 * CPHEC;      # inlet --> outlet of wall pipe node #349
GF( 5057, 5058 ) = MFLO2 * CPHEC;      # inlet --> outlet of wall pipe node #350
GF( 5058, 5059 ) = MFLO2 * CPHEC;      # inlet --> outlet of wall pipe node #351
GF( 5059, 5060 ) = MFLO2 * CPHEC;      # inlet --> outlet of wall pipe node #352
#
# Conductors between pipe wall nodes and helium downstream node within relevant
# pipe section
# Heat transfer by forced convection, laminar flow, J. Hinger, 30.10.2001
#
#                               mass flow rate
#                               |      Wall temperature
#                               |      |      Upstream helium temp.
#                               |      |      |      Downstream helium temp.
#                               |      |      |      |      Pipe length between up-&
#                               |      |      |      |      |      downstream helium node
#
GL( 320, 5010 ) = HTRANS( MFLO2, T320, T5000, T5010, 0.700D0); #
GL( 321, 5011 ) = HTRANS( MFLO2, T321, T5010, T5011, 0.050D0); #
GL( 322, 5012 ) = HTRANS( MFLO2, T322, T5011, T5012, 0.020D0); #
GL( 323, 5013 ) = HTRANS( MFLO2, T323, T5012, T5013, 0.050D0); #
GL( 324, 5014 ) = HTRANS( MFLO2, T324, T5013, T5014, 0.220D0); #
GL( 325, 5020 ) = HTRANS( MFLO2, T325, T5014, T5020, 1.000D0); #
GL( 326, 5021 ) = HTRANS( MFLO2, T326, T5020, T5021, 0.050D0); #
GL( 327, 5022 ) = HTRANS( MFLO2, T327, T5021, T5022, 0.020D0); #
GL( 328, 5023 ) = HTRANS( MFLO2, T328, T5022, T5023, 0.050D0); #
GL( 329, 5024 ) = HTRANS( MFLO2, T329, T5023, T5024, 0.340D0); #
GL( 330, 5030 ) = HTRANS( MFLO2, T330, T5024, T5030, 0.140D0); #

```

```

GL( 331, 5031 ) = HTRANS( MFLO2, T331, T5030, T5031, 0.050D0); #
GL( 332, 5032 ) = HTRANS( MFLO2, T332, T5031, T5032, 0.020D0); #
GL( 333, 5033 ) = HTRANS( MFLO2, T333, T5032, T5033, 0.050D0); #
GL( 334, 5034 ) = HTRANS( MFLO2, T334, T5033, T5034, 0.310D0); #
GL( 335, 5035 ) = HTRANS( MFLO2, T335, T5034, T5035, 0.410D0); #
GL( 336, 5040 ) = HTRANS( MFLO2, T336, T5035, T5040, 0.410D0); #
GL( 337, 5041 ) = HTRANS( MFLO2, T337, T5040, T5041, 0.050D0); #
GL( 338, 5042 ) = HTRANS( MFLO2, T338, T5041, T5042, 0.020D0); #
GL( 339, 5043 ) = HTRANS( MFLO2, T339, T5042, T5043, 0.050D0); #
GL( 340, 5044 ) = HTRANS( MFLO2, T340, T5043, T5044, 0.410D0); #
GL( 341, 5045 ) = HTRANS( MFLO2, T341, T5044, T5045, 0.510D0); #
GL( 342, 5050 ) = HTRANS( MFLO2, T342, T5045, T5050, 0.610D0); #
GL( 343, 5051 ) = HTRANS( MFLO2, T343, T5050, T5051, 0.050D0); #
GL( 344, 5052 ) = HTRANS( MFLO2, T344, T5051, T5052, 0.020D0); #
GL( 345, 5053 ) = HTRANS( MFLO2, T345, T5052, T5053, 0.050D0); #
GL( 346, 5054 ) = HTRANS( MFLO2, T346, T5053, T5054, 0.450D0); #
GL( 347, 5055 ) = HTRANS( MFLO2, T347, T5054, T5055, 0.950D0); #
GL( 348, 5056 ) = HTRANS( MFLO2, T348, T5055, T5056, 0.370D0); #
GL( 349, 5057 ) = HTRANS( MFLO2, T349, T5056, T5057, 0.580D0); #
GL( 350, 5058 ) = HTRANS( MFLO2, T350, T5057, T5058, 0.340D0); #
GL( 351, 5059 ) = HTRANS( MFLO2, T351, T5058, T5059, 1.000D0); #
GL( 352, 5060 ) = HTRANS( MFLO2, T352, T5059, T5060, 0.510D0); #

```

#

#

```
DOUBLE PRECISION FUNCTION HTRANS( MASSFL, TWALL, TFLUI1, TFLUI2, LPIPE)
```

#

```
Author: J. Hinger, 30.10.2001
```

#

```
HTRANS computes the thermal conductance between pipe wall node and downstream fluid node
```

#

```
by forced convection within a pipe with hydrodynamic fully developed velocity profile
```

#

```
and laminar flow and constant wall temperature, according to VDI-Wärmeatlas, 5. Auflage 1988
```

#

```
A constant wall temperature is assumed for the pipe section this function is applied to
```

#

```
DOUBLE PRECISION MASSFL, TWALL, TFLUI1, TFLUI2, LPIPE
DOUBLE PRECISION PIII, TREF, ETA_HE, LAM_HE, DIAMI, REYNLD
DOUBLE PRECISION PRANDT, NUSSD, FACTOR, ALPHA, XPON
```

#

```
Input parameters
```

#

```
MASSFL          helium mass flow rate (kg/s)
TWALL           Temperature of pipe wall (K)
TFLUI1          Fluid inlet temperature (K)
TFLUI2          Fluid outlet temperature (K)
LPIPE           pipe length between inlet and outlet fluid node (m)
```

#

```
Local variables
```

#

```
PI              3.1415926
TREF            Reference temperature for fluid properties in boundary layer (K)
ETA_HE          dynamic viscosity of helium gas (N s / m2)
LAM_HE          conductivity of gaseous helium (W/(mK))
DIAMI           internal pipe diameter (m)
REYNLD          Reynolds Number, related to pipe internal diameter
PRANDT          Prandtl Number of helium gas
CPHEC           mass-specific capacity at const. pressure of helium gas (J/(kgK))
NUSSD           Nusselt number related to internal pipe diameter
FACTOR          Abbreviation
ALPHA           Film coefficient for forced convection (W/(m2K))
```

```
#      XPON      exponent in heat transfer function
#
#
      PIII = 3.1415927D0
      TREF  = .5D0*(.5D0*(TFLUI1+TFLUI2)+TWALL)
      ETA_HE = INTRP1(TREF, GHEMTAB, 1)
      LAM_HE = INTRP1(TREF, GHELTAB, 1)
#
      DIAMI = 0.012
      REYNLD = 4.D0*MASSFL/(PIII*DIAMI*ETA_HE)
      PRANDT = ETA_HE * CPHEC / LAM_HE
      FACTOR = REYNLD*PRANDT*DIAMI/LPIPE
      NUSSD = 3.65D0 + (0.19D0*FACTOR**.8D0)/(1.D0 + 0.117D0*FACTOR**0.467D0)
      ALPHA = NUSSD * LAM_HE / DIAMI
#
      IF (MASSFL .LE. 0.) THEN      # avoid "division by zero" error for
MDOT = 0 run KW
      HTRANS = 0.
      ELSE
        XPON = ALPHA*PIII*DIAMI*LPIPE/(MASSFL*CPHEC)
        IF (XPON.LE.3.D0) THEN
          HTRANS = MASSFL * CPHEC * ( EXP(XPON) - 1.D0 )
        ELSE
          HTRANS = MASSFL * CPHEC * 19.09D0      # avoid numerical instabilities
        END IF
      END IF
#
#
      RETURN
      END
#
```

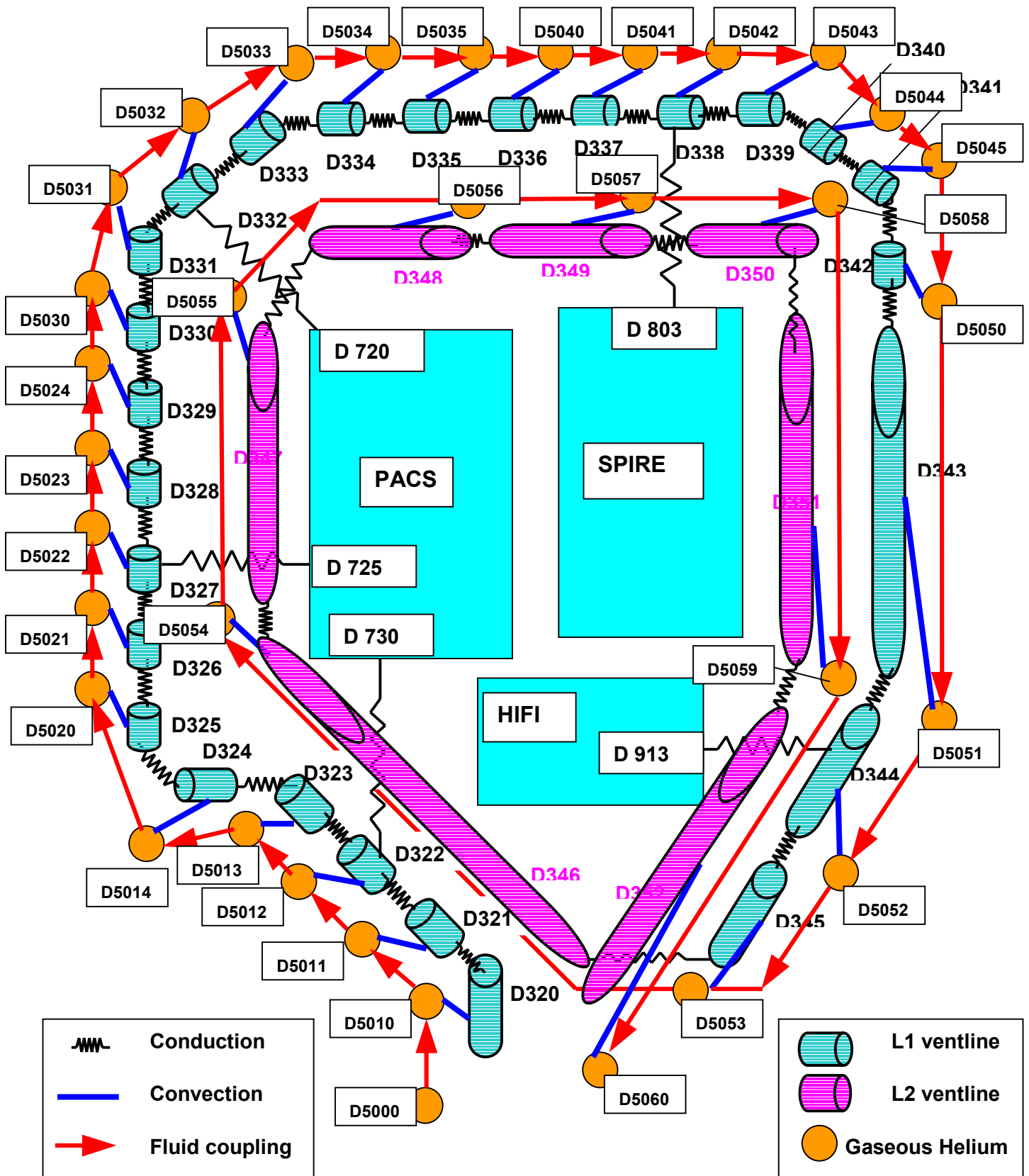



Figure 4-26: Optical Bench ventline model

4.5 Submodel “CTCE”, Cryo Test Cavity for EQM

4.5.1 CTCE Requirements

The CTCE thermal requirements will be specified in RD 19. Preliminary thermal design requirements are taken from a draft version of RD 19 and are summarized hereafter:

- Internal wall of cavity to be cooled < 5 K
- Reflector with low-emissive optical coating $e < 0.04$, temperature controlled at 60K to 80 K, goal (40 K to 80 K), stable at < 1 K during 5 minutes.
- Black body target highly emissive ($e > 0.97$) and temperature controlled < 5 K.

For straylight and cleanliness reasons the innermost surface of the cavity (shroud) shall be non-coated, i.e. blank aluminium with a low emissivity of less than 0.05 (TBC). For the top shroud, however, a high emissivity is desired.

Remark: From thermal point of view the emissivity of the cavity walls is of minor importance since in a cavity rays generally are totally absorbed by multireflections at the walls and can rather escape.

4.5.2 CTCE Thermal Design Concepts

From the a.m. thermal as well as optical requirements and the CVV-mechanical interface defined in RD 06 two preliminary thermal design concepts are derived and thermally analysed:

- Design 1: With MLI blankets between vapor-cooled heatshields
- Design 2: Without any MLI-blankets, only vapor-and radiatively cooled heatshields

For both concepts the following common design features/guidelines hold:

- The CTCE is a separate cryostat with a vapor-cooled shroud and a vapor-cooled heatshield within a vacuum-vessel. The helium-vapor is provided by an external dewar at a temperature of 4.2 K (He I) corresponding to a saturation pressure of 990 mbar.
- Preliminary dimensions as shown in Fig. 4-14 and Fig. 4-15
- Internal shroud. Cylindrical part connected to ventline (2 loops around perimeter). Blank alu, 1 mm thickness, emissivity = 0.05 for all shroud surfaces incl. Top shroud (conserveative “hot case” assumption for instruments).
- 270 mm diameter baffle (1mm alu, emissivity 0.05) penetrating the cryostat opening and shielding the EQM-cryostat heatshields. Thermally very well connected to vapor-cooled shroud.

- Top shroud (circular disc, 1mm thick alu) thermally very well connected to vapor-cooled cylindrical part, emissivity = 0.05
- Vapor-cooled heatshields Cylindrical part connected to ventline (2 loops around perimeter). Blank alu, 1 mm thickness, emissivity = 0.05
- Heatshield mounted on vessel via 8 VESPEL-standoffs of 10 x 2 mm² cross-section, 25 mm height each.
- Shroud mounted on heatshiled via 8 VESPEL-standoffs of 10 x 2 mm² cross-section, 25 mm height each.
- Reflector interface brackets (alu) mounted on vessel by 3 low-conductive joints, each. An example for such a joint design is given in Figure 4-36. Alternatively the reflector can be mounted via 3 struts on a common optical bench.
- Reflector (rear side emissivity = .05 diffusive, front side 0.05 specular). Shall be temperature controlled at 40 to 80 K. Hence it follows that it must be extremely good decoupled from the vacuum vessel that is at ambient temperature (290 K). This is performed by using VESPEL (polyimide)-tubes as struts (d= 20 mm, t= 1 mm). The integral conductivity over a temperature range of 40K to 300 K of VESPEL is 0.254 W/(mK) compared to 0.649 W/(mK) of S-glass-fibre-composite.
The struts shall not directly be mounted to the vessel, but mounted to a bracket or an optical bench. This optical bench shall be coupled to the ventlines coming from the shrouds as illustrated in Figure 4-32. The optical bench or brackets shall be thermally decoupled from the vessel using low-conductive joints. An example of such a joint is given in Figure 4-36.

4.5.2.1 CTCE Design Concept 1

This design shown in Figure 4-28 stands out for using MLI-blankets as thermal insulation between the vapor-cooled shroud and the vapor-cooled heatshield.

- MLI-blankets between vessel and heatshield, attached on heatshield.
Conductance twice as high as for HERSCHEL assumed (conservative assumption)
- MLI-blankets between heatshield and shroud, attached on shroud.
Conductance twice as high as for HERSCHEL assumed (conservative assumption)

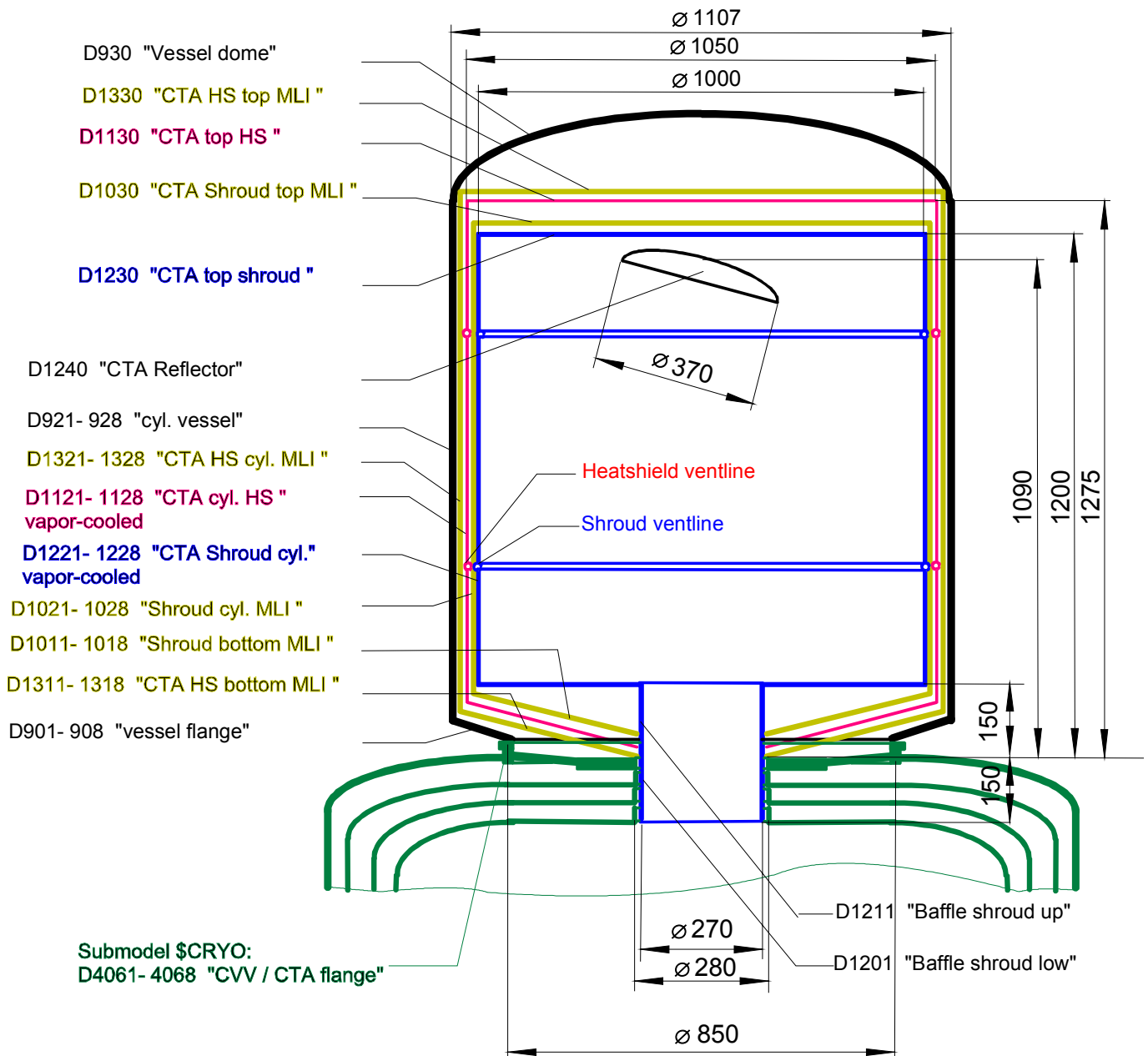

Figure 4-28: CTCE-design1 outline and thermal nodes distribution

4.5.2.2 CTCE Design Concept 2

Instead of MLI-blankets 3 additional but only passively cooled heatshields as shown in Fig. 4-15 are used. The advantage of such a design is:

- to save time and costs by avoiding expensive class-100 MLI blankets manufacturing, shipment and integration
- heatshield are easy to clean and have low risks of particle contamination compared to conventional MLI-spacers (Dacron) when cutting it.

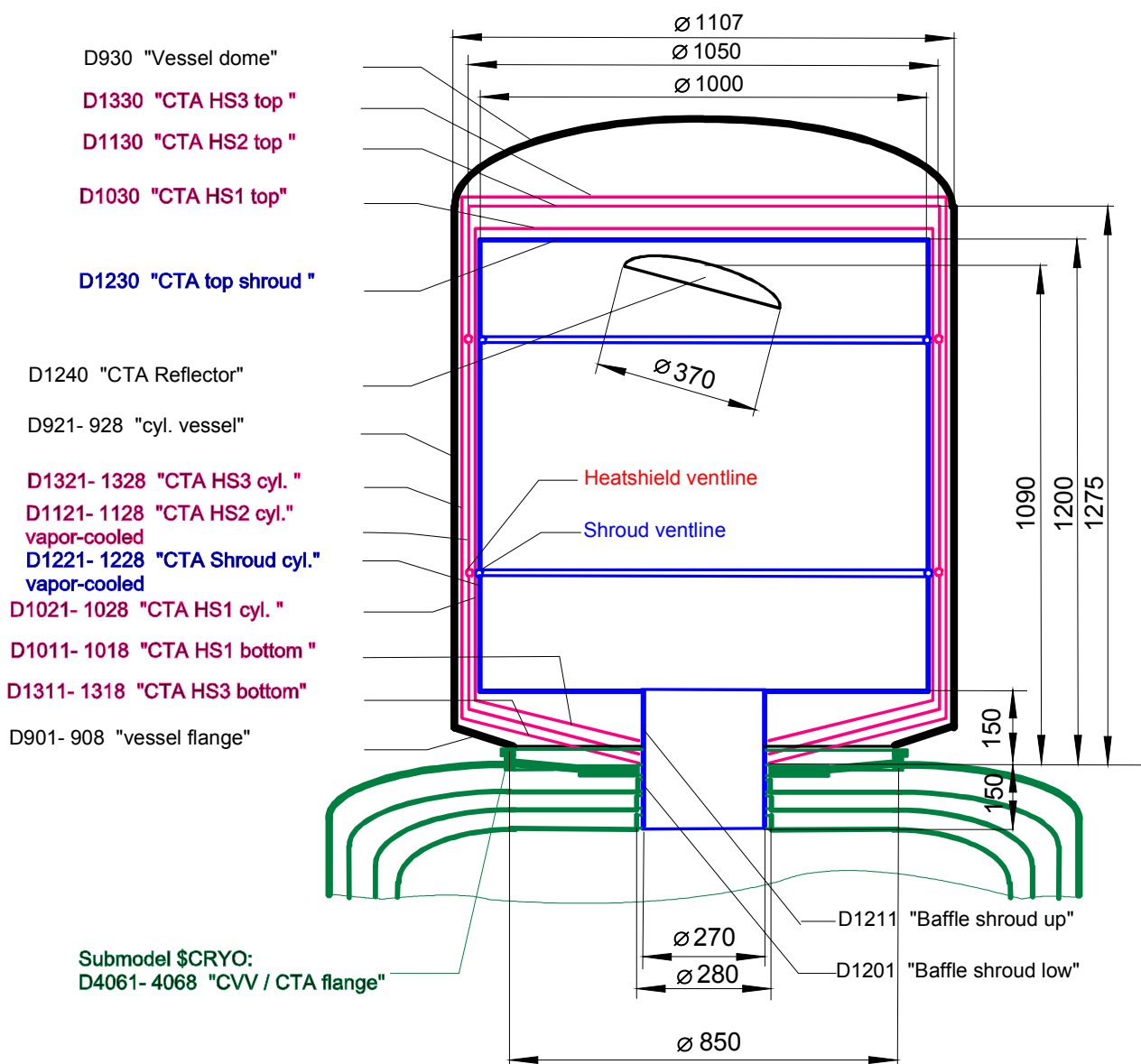

Figure 4-30: CTCE-design2 outline and thermal nodes distribution

4.5.3 CTCE Ventline Design and Modelling

The ventline for the CTCE shroud, optical bench (or reflector strut I/F brackets) and heatshield cooling is modelled as illustrated in Figure 4-34. The ventline heat exchange computation method is identical to the one used for the payload OB ventline as defined in § 4.4.2.

Note: It has been demonstrated by thermal analysis that it is not possible to directly mount the reflector by low-conductive struts to the CTCE-vessel. This is due to the fact that the CTCE vessel is at ambient temperature and too much heat would be conducted into the reflector although a low conductive material such as VESPEL or glass-fibre would be used for the struts. As a result the reflector temperature would reach more than 100 K violating the 40K – 80 K requirement. In order to avoid a further expensive cooling system (liquid nitrogen) it is mandatory to mount the reflector-struts to an interface bracket or optical bench that in turn is connected to the existing ventline. In this way instead of an additional LN2-cooling-system only a low-cost electrical heater on the reflector is required. The temperature level of the reflector can be adjusted by adjusting the heater power of this heater.

The thermal design concept of the reflector attachment is shown in Figure 4-32. Instead of I/F brackets a common optical bench can be designed.

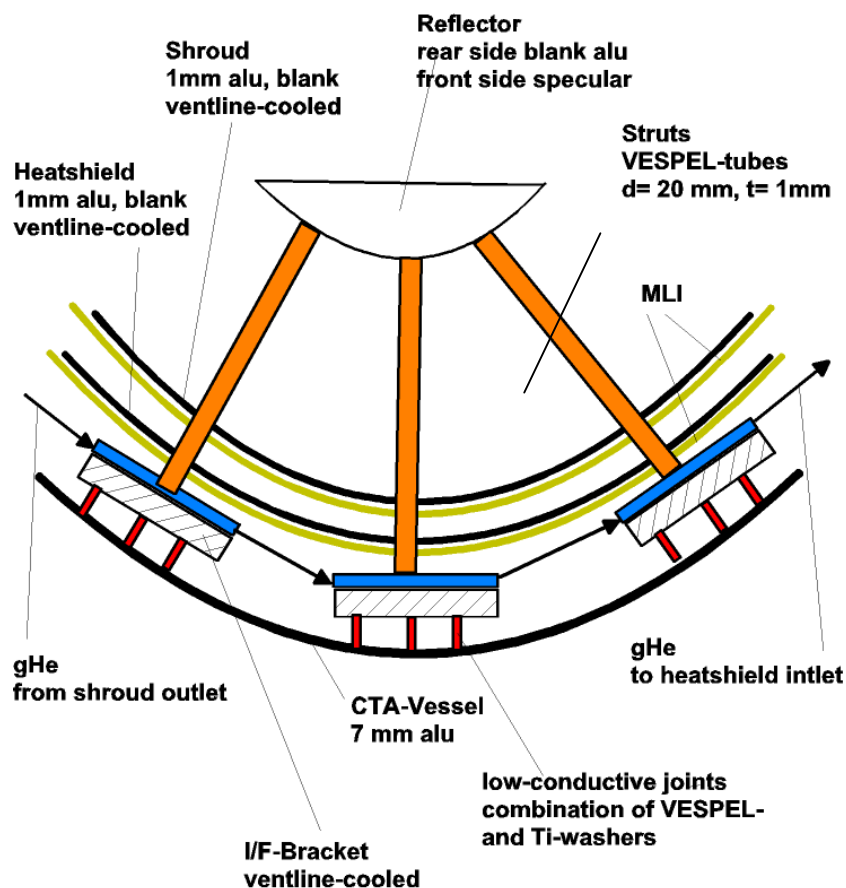

Figure 4-32: Thermal design of Reflector attachment

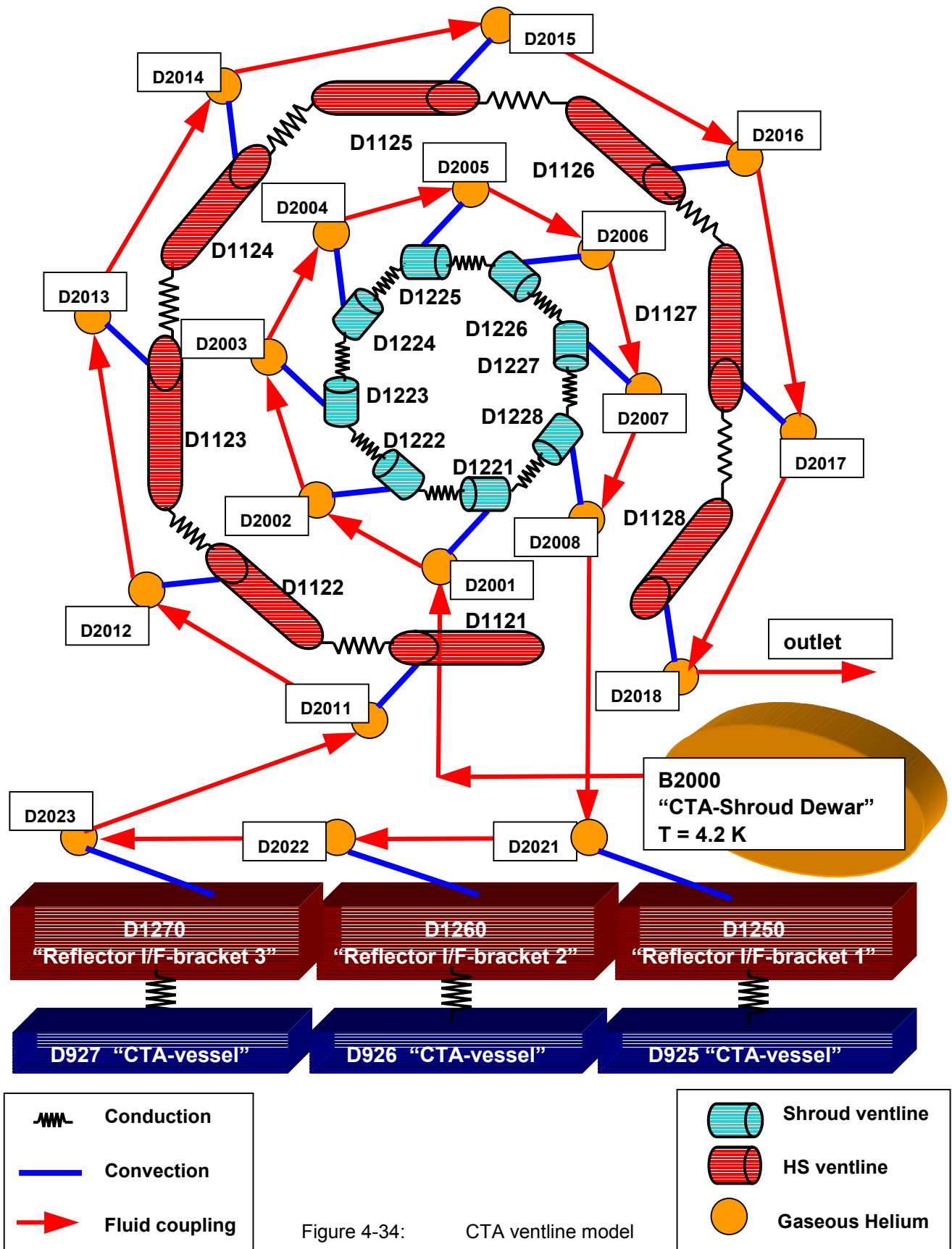

Figure 4-34: CTA ventline model

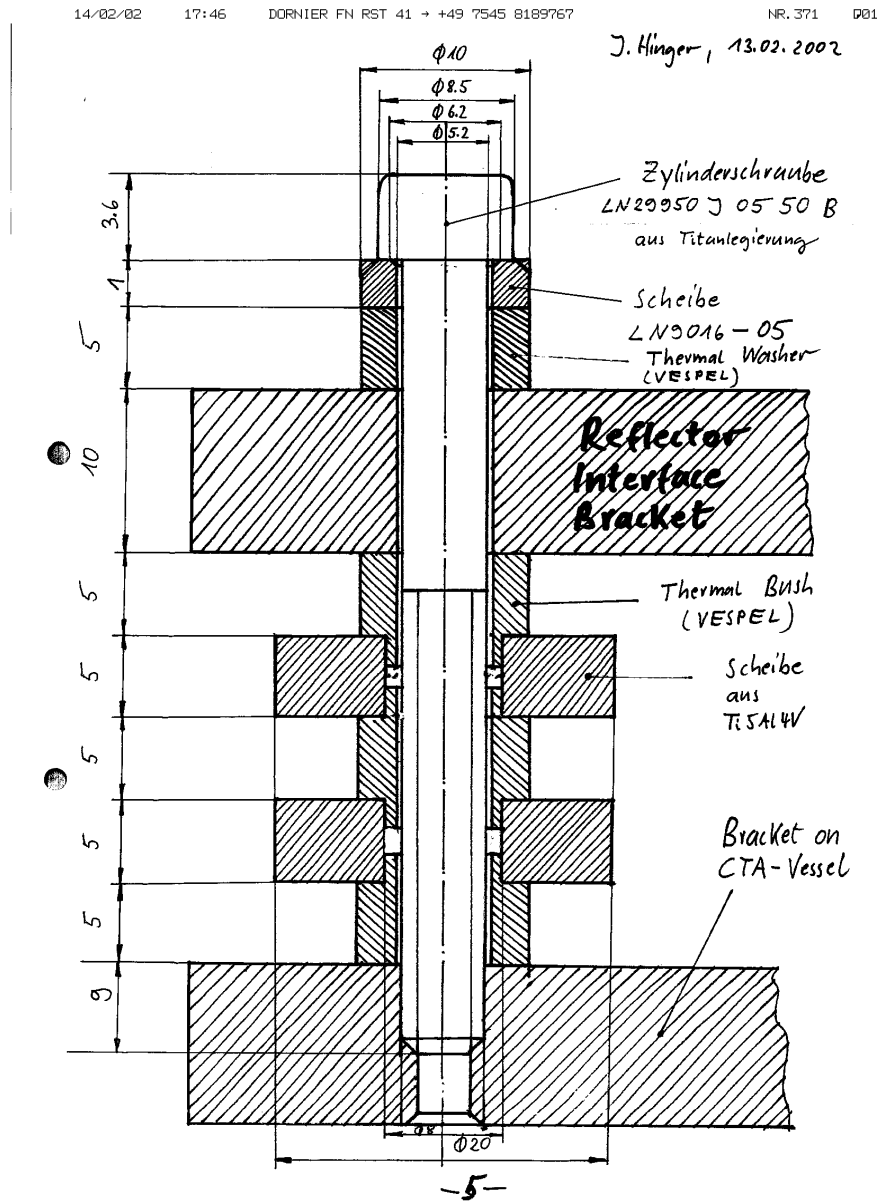

Figure 4-36: Example for a low-conductive joint.

4.5.4 Geometrical-mathematical Model of Cryogenic Test Cavity

The cavity-model in ESARAD-format is illustrated in Figure 4-19. It is used to compute the radiative exchange factors within the cavity formed by the CTCE-shrouds and the HERSCHEL-payload within the instrument shield. This model is identical for the CTCE design 1 as well as for design 2.

The thermal nodes distribution of the ESATAN-TMM are included in Figure 4-14.

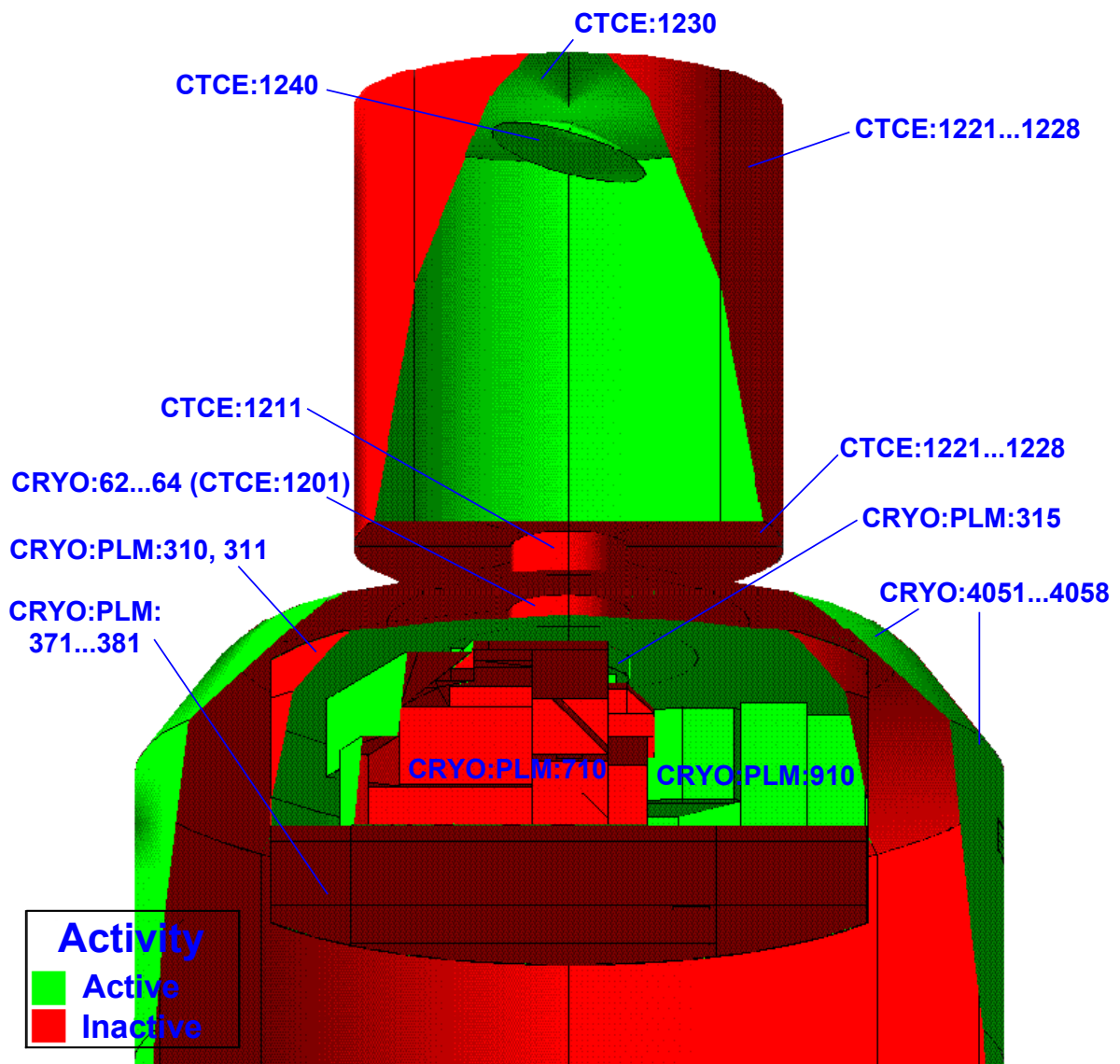

Figure 4-38: ESARAD-model of CTCE/cryostat cavity

4.6 Submodel “CPLATE”, CTA Cold Plate for EQM

As an alternative to the CTCE cryostat design a simple vacuum-tight plate with a helium-cooled mirror support plate has been proposed on the CTA meeting held at ESTEC on 26.04.2002. The thermal model is illustrated in Figure 4-40.

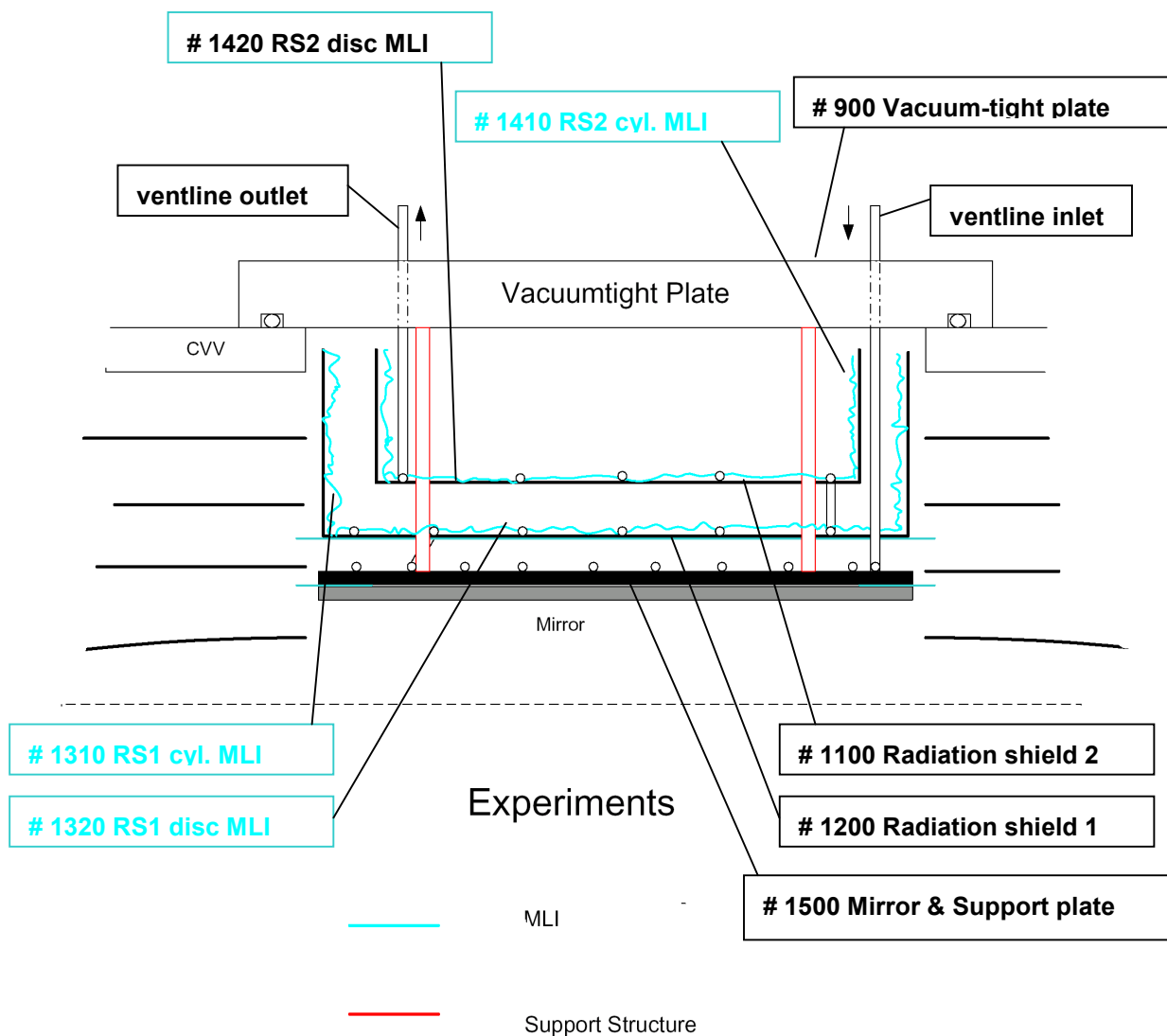

Figure 4-40: Vacuum-tight Plate Design, Thermal network

4.6.1 CTA Coldplate Requirements

Several optical mirror surfaces have been identified on the CTA meeting held at ESTEC on 26.04.2002. From thermal point of view two extreme emissivities $e = 0.9$ (blackened) and $e = 0.04$ (sandblasted, honeycomb, Fresnel etc.) diffusive and $e = 0.04$ specular are relevant. In the following analysis $e = 0.9$ and $e = 0.04$ (diffusive) are considered.

The temperature stability requirement is ± 1 K during 10 s which is judged to be no problem.

There are no temperature level requirements specified yet. However, the goal is to achieve temperatures lower than 10 K at the mirror.

4.6.2 CTA Coldplate Design concept

Only a preliminary design concept is available. For thermal modelling the following assumptions have been taken:

- 30 mm thick alu vacuum-tight plate closely coupled to CVV
- Mirror and mirror plate made of a 10 mm thick alu plate, $D = 280$ mm, respectively
- radiation shields made of 1 mm thick alu sheets
- Mirror plate mounted to vacuum-tight plate via 9 VESPEL (Polyimide) tubes, $D_a/D_i = 20/16$ mm, $l = 100$ mm.
- ventline SST-pipe, $D_a/D_i = 5/4$ mm, thoroughly thermally decoupled from vacuum-tight plate.
- Radiation shields connected by low-conductive VESPEL-standoffs.
- MLI performance as assumed for CTCE-cryostat design concept 1.
- Ventline modelling equivalent to CTCE-cryostat concept but with fewer nodes.
- External HeI-Dewar at 4.2 K assumed

5 Thermal Analysis Results

The following parameters are not adjusted during the test. They are 'adjusted' by the ventline design and are dictated by the environment, i.e. ambient pressure:

- Pressure within main tank (in analysis 4.2 K, in reality 4.2 to 4.4 K)
- Pressure of tank within external dewar (in analysis 4.2 K, in reality 4.2 to 4.4 K). If lower temperatures are requested a second vacuum pump is available

There are the following parameters to be adjusted during the test:

- Pressure within EQM-aux. tank by vacuum-pump → adjustment of aux. tank temperature (currently 1.7 K)
- Heater power of main tank → adjustment of main tank mass-flow rate
- Heater power of aux. Tank → adjustment of flight-representative value of approx. 2.1 mg/s
- Heater power of tank within external dewar → adjustment of mass flow rate
- Heater power of reflector → adjustment of temperature

The thermal-mathematical model is capable to adjust all these parameters in order to fulfill the following requirements:

- Instrument L0-temperatures within requirements
- Instrument L1-temperatures within requirements
- Instrument L2-temperatures within requirements
- CTCE-shroud less than 5 K
- Reflector within CTCE adjustable at 40K to 80 K

The two CTCE-design concepts 1 and 2 have been analysed

5.1 CTCE-Design-1 Case 1

CTCE-design1 means: MLI-design concept for CTCE as defined in § 4.5.2.1

Case 1 means: EQM-aux. Tank heater power = 0 mW

The input parameters are compiled in Table 5-1 and a brief temperature results summary is given in Table 5-3. The complete ESATAN-output-file listing is appended. The respective node numbers and labels are referenced in the thermal design and thermal-mathematical model descriptions in § 4

Input parameter	
Main Tank temperature	4.2 K
EQM-aux. Tank temperature	1.7 K
External Hel dewar temp. for CTCE-shroud cooling	4.2 K
Main Tank heater power	2000 mW
EQM-auxiliary tank heater power	0 mW
CTCE-shroud He-mass flow rate	100 mg/s
Reflector heater power	0 mW

Table 5-1: Input parameters

Submodel	Node #	Node Label	T (K)	T _{max} (K) required	Require ment fulfilled
CRYO	12, 22, 32	Heatshield 1	10 - 16	NA	NA
CRYO	13, 23, 33	Heatshield 2	22 - 38	NA	NA
CRYO	14, 15, 24, 25, 34, 35	Heatshield 3	97 - 142	NA	NA
CRYO	4001 - 4078	CVV	293	NA	NA
CRYO	4090	LOU window	290	NA	NA
CRYO:PLM	371 - 381	Optical Bench	12 - 13	15	yes

Submodel	Node #	Node Label	T (K)	T _{max} (K) required	Requirement fulfilled
CRYO:PLM	811	SPIRE SM Detector enclosure	1.80	1.8	yes
CRYO:PLM	819	SPIRE Cooler Pump HS	1.78	1.8	yes
CRYO:PLM	820	SPIRE Cooler Evaporator HS	1.73	1.8	yes
CRYO:PLM	765	PACS Blue Detector	1.73	3.5	yes
CRYO:PLM	760	PACS Red Detector	1.71	1.75	yes
CRYO:PLM	781	PACS He-Pump	1.78	2.20	yes
CRYO:PLM	912	HIFI I0-Boundary	1.89	2.00	yes
CRYO:PLM	803	SPIRE Optical Bench	6.0	4.5	No 1)
CRYO:PLM	730	PACS Photometer Optics	3.5	5	yes
CRYO:PLM	725	PACS Collimator	3.5	5	yes
CRYO:PLM	720	PACS Spectrom. Housing	3.5	5	yes
CRYO:PLM	913	HIFI L1-interface	7.4	6	no
CRYO:PLM	801	SPIRE PM JFET enclosure	15	13	yes
CRYO:PLM	802	SPIRE SM JFET enclosure	15	13	yes
CRYO:PLM	910	HIFI FPU Structure	20	13	yes
CTCE	901 -930	CTCE vessel	292	NA	NA
CTCE	1221 - 1230	CTA-shroud	4.5 – 5.1	5	yes
CTCE	1121 – 1130	CTA- heatshield	50 - 65	NA	NA
CTCE	1240	CTA-Reflector	21	40 -80	no *)
CTCE	1250, 1260, 1270	Reflector interface brackets (or optical bench)	19 - 25	NA	NA
		Mass-flow rate (mg/s)	required mass-flow rate (mg/s)	Requirement fulfilled	
Out of main tank		98	NA**)	NA	
Out of EQM-auxiliary tank		1.57	2.1	no ***)	
Out of external He-dewar for CTA-shroud cooling		100	NA **)	NA	

1) requirement not yet approved by ASED

*) can easily be controlled at 40 –80 K by electrically heating

***) to be verified whether pressure drop is not too high

****) can easily be increased by electrical heating

Table 5-3: Brief results summary

EUROPEAN SPACE AGENCY THERMAL ANALYSIS NETWORK
 (VERSION 8.5.0) PAGE 1 14 FEBRUARY 2002
 14:01:04 EQM4

```
#####
#
# Main Tank heater power:      2000 mW
# Aux. Tank heater power:      0 mW
# CTCE-shroud mass flow rate:  100 mg/s
# Reflector HTR power:         0 mW
#
#####
```

+EQM4:CRYO

NODE		LABEL	T	QI	QR	C
1	MAIN TANK		4.200	0.00000	2.00000	0.000
2	AUX TANK		1.700	0.00000	0.00000	0.000
5	Ti-head	lo 5	11.286	0.00000	0.00000	71.074
6	belt fitting	lo 6	10.677	0.00000	0.00000	63.244
7	strut tank end	lo 7	4.359	0.00000	0.00000	21.851
8	Ti-head	up 8	12.453	0.00000	0.00000	80.973
9	belt fitting	up 9	11.845	0.00000	0.00000	72.852
10	strut tank end	up 10	4.413	0.00000	0.00000	22.132
12	HS 1 BULK 12		10.584	0.00000	0.00000	13.997
13	HS 2 BULK 13		22.919	0.00000	0.00000	138.905
14	HS 3 BULK +Z 14		119.405	0.00000	0.00000	2765.069
15	HS 3 BULK -Z 15		119.371	0.00000	0.00000	2764.425
22	HS 1 CYL 22		10.510	0.00000	0.00000	44.559
23	HS 2 CYL 23		21.909	0.00000	0.00000	327.392
24	HS 3 CYL +Z 24		97.432	0.00000	0.00000	6843.058
25	HS 3 CYL -Z 25		97.330	0.00000	0.00000	6833.728
32	HS 1 CONE 32		15.534	0.00000	0.00000	91.723
33	HS 2 CONE 33		37.938	0.00000	0.00000	1503.855
34	HS 3 CONE +Z 34		142.204	0.00000	0.00000	7722.538
35	HS 3 CONE -Z 35		142.410	0.00000	0.00000	7722.538
42	HS 1 HIFI Baf. int.		25.647	0.00000	0.00000	2.930
52	HS 1 HIFI Baf. ext.		32.973	0.00000	0.00000	2.674
53	HS 2 HIFI Baf.		57.531	0.00000	0.00000	10.606
54	HS 3 HIFI Baf.		175.182	0.00000	0.00000	45.557
62	HS 1 Tele BAF		15.562	0.00000	0.00000	0.346
63	HS 2 Tele BAF		38.124	0.00000	0.00000	5.521
64	HS 3 Tele BAF		142.110	0.00000	0.00000	81.043
101	MLI MAIN TANK LO 101		5.164	0.00000	0.00000	15.675
105	MLI MAIN TANK CY 105		4.732	0.00000	0.00000	43.316
106	MLI MAIN TANK UP 106		37.082	0.00000	0.00000	112.572
112	MLI HS 1 BULK 112		20.265	0.00000	0.00000	39.833
113	MLI HS 2 BULK 113		114.964	0.00000	0.00000	381.490
114	MLI HS 3 BULK +Z 114		287.450	0.00000	0.00000	706.436
115	MLI HS 3 BULK -Z 115		287.427	0.00000	0.00000	706.378
122	MLI HS 1 CYL 122		19.202	0.00000	0.00000	122.659
123	MLI HS 2 CYL 123		93.569	0.00000	0.00000	967.500
124	MLI HS 3 CYL +Z 124		286.651	0.00000	0.00000	2100.812
125	MLI HS 3 CYL -Z 125		285.591	0.00000	0.00000	2093.042
132	MLI HS 1 CONE 132		51.481	0.00000	0.00000	249.729
133	MLI HS 2 CONE 133		137.697	0.00000	0.00000	1124.793
134	MLI HS 3 CONE +Z 134		287.292	0.00000	0.00000	1702.056
135	MLI HS 3 CONE -Z 135		287.272	0.00000	0.00000	1701.936
440	filling tube	440	271.525	0.00000	0.00000	0.000
441	filling tube	441	252.223	0.00000	0.00000	0.000
442	filling tube	442	245.518	0.00000	0.00000	0.000

443	filling tube	443	242.458	0.00000	0.00000	0.000
447	empty tube	447	15.522	0.00000	0.00000	0.000
452	empty tube	452	10.869	0.00000	0.00000	0.000
502	line baf to HS1	502	4.201	0.00000	0.00000	0.000
642	MLI filling tube	642	120.438	0.00000	0.00000	0.766
643	MLI filling tube	643	119.020	0.00000	0.00000	0.743
647	MLI filling tube	647	25.824	0.00000	0.00000	1.245
652	MLI filling tube	652	23.559	0.00000	0.00000	0.459
1000	HS 1 SUSP BOLT	1000	19.621	0.00000	0.00000	0.000
2000	HS 2 SUSP BOLT	2000	67.854	0.00000	0.00000	0.000
3000	HS 3 SUSP BOLT	3000	189.799	0.00000	0.00000	0.000
4001	CVV lower bulk	4001	292.764	0.00000	0.00000	4399.463
4002	CVV lower bulk	4002	292.771	0.00000	0.00000	4399.491
4003	CVV lower bulk	4003	292.771	0.00000	0.00000	4399.491
4004	CVV lower bulk	4004	292.764	0.00000	0.00000	4399.462
4005	CVV lower bulk	4005	292.750	0.00000	0.00000	4399.407
4006	CVV lower bulk	4006	292.749	0.00000	0.00000	4399.403
4007	CVV lower bulk	4007	292.758	0.00000	0.00000	4399.441
4008	CVV lower bulk	4008	292.760	0.00000	0.00000	4399.449
4011	CVV lower bulk	4011	292.707	0.00000	0.00000	1668.975
4012	CVV lower bulk	4012	292.740	0.00000	0.00000	1669.025
4013	CVV lower bulk	4013	292.741	0.00000	0.00000	1669.027
4014	CVV lower bulk	4014	292.717	0.00000	0.00000	1668.991
4015	CVV lower bulk	4015	292.654	0.00000	0.00000	1668.893
4016	CVV lower bulk	4016	292.654	0.00000	0.00000	1668.893
4017	CVV lower bulk	4017	292.705	0.00000	0.00000	1668.971
4018	CVV lower bulk	4018	292.700	0.00000	0.00000	1668.964
4031	CVV cyl lower	4031	292.553	0.00000	0.00000	13706.678
4032	CVV cyl lower	4032	292.660	0.00000	0.00000	13708.038
4033	CVV cyl lower	4033	292.663	0.00000	0.00000	13708.073
4034	CVV cyl lower	4034	292.599	0.00000	0.00000	13707.260
4035	CVV cyl lower	4035	292.391	0.00000	0.00000	13704.643
4036	CVV cyl lower	4036	292.396	0.00000	0.00000	13704.702
4037	CVV cyl lower	4037	292.568	0.00000	0.00000	13706.873
4038	CVV cyl lower	4038	292.537	0.00000	0.00000	13706.477
4041	CVV cyl upper	4041	292.694	0.00000	0.00000	19514.607
4042	CVV cyl upper	4042	292.699	0.00000	0.00000	19514.695
4043	CVV cyl upper	4043	292.633	0.00000	0.00000	19513.510
4044	CVV cyl upper	4044	292.215	0.00000	0.00000	19506.001
4045	CVV cyl upper	4045	289.655	0.00000	0.00000	19459.994
4046	CVV cyl upper	4046	289.649	0.00000	0.00000	19459.899
4047	CVV cyl upper	4047	292.186	0.00000	0.00000	19505.469
4048	CVV cyl upper	4048	292.603	0.00000	0.00000	19512.975
4051	CVV upper bulk	4051	292.714	0.00000	0.00000	19050.967
4052	CVV upper bulk	4052	292.627	0.00000	0.00000	19049.441
4053	CVV upper bulk	4053	292.618	0.00000	0.00000	19049.276
4054	CVV upper bulk	4054	292.669	0.00000	0.00000	19050.185
4055	CVV upper bulk	4055	292.589	0.00000	0.00000	19048.773
4056	CVV upper bulk	4056	292.545	0.00000	0.00000	19047.996
4057	CVV upper bulk	4057	292.681	0.00000	0.00000	19050.383
4058	CVV upper bulk	4058	292.719	0.00000	0.00000	19051.062
4061	CVV/CTA flange	4061	292.330	0.00000	0.00000	0.000
4062	CVV/CTA flange	4062	292.307	0.00000	0.00000	0.000
4063	CVV/CTA flange	4063	292.286	0.00000	0.00000	0.000
4064	CVV/CTA flange	4064	292.263	0.00000	0.00000	0.000
4065	CVV/CTA flange	4065	292.240	0.00000	0.00000	0.000
4066	CVV/CTA flange	4066	292.244	0.00000	0.00000	0.000
4067	CVV/CTA flange	4067	292.298	0.00000	0.00000	0.000
4068	CVV/CTA flange	4068	292.326	0.00000	0.00000	0.000
4071	CVV flange disc	4071	292.174	0.00000	0.00000	0.000
4072	CVV flange disc	4072	292.161	0.00000	0.00000	0.000
4073	CVV flange disc	4073	292.144	0.00000	0.00000	0.000
4074	CVV flange disc	4074	292.126	0.00000	0.00000	0.000

4075	CVV flange disc	4075	292.114	0.00000	0.00000	0.000
4076	CVV flange disc	4076	292.121	0.00000	0.00000	0.000
4077	CVV flange disc	4077	292.150	0.00000	0.00000	0.000
4078	CVV flange disc	4078	292.171	0.00000	0.00000	0.000
4090	CVV Lo window		289.928	0.00000	0.00000	15.604
4631	SUSP TI lo	4631	282.780	0.00000	0.00000	84.266
4632	SUSP TI lo	4632	282.879	0.00000	0.00000	84.277
4633	SUSP TI lo	4633	282.882	0.00000	0.00000	84.277
4634	SUSP TI lo	4634	282.822	0.00000	0.00000	84.271
4635	SUSP TI lo	4635	282.632	0.00000	0.00000	84.250
4636	SUSP TI lo	4636	282.636	0.00000	0.00000	84.251
4637	SUSP TI lo	4637	282.794	0.00000	0.00000	84.268
4638	SUSP TI lo	4638	282.765	0.00000	0.00000	84.264
4641	SUSP TI up	4641	282.910	0.00000	0.00000	84.280
4642	SUSP TI up	4642	282.914	0.00000	0.00000	84.280
4643	SUSP TI up	4643	282.854	0.00000	0.00000	84.274
4644	SUSP TI up	4644	282.469	0.00000	0.00000	84.233
4645	SUSP TI up	4645	280.114	0.00000	0.00000	83.982
4646	SUSP TI up	4646	280.109	0.00000	0.00000	83.982
4647	SUSP TI up	4647	282.442	0.00000	0.00000	84.230
4648	SUSP TI up	4648	282.826	0.00000	0.00000	84.271
4731	CABLE PLUG	4731	281.499	0.00073	0.00000	93.529
4732	CABLE PLUG	4732	291.588	0.00000	0.00000	97.058
4733	CABLE PLUG	4733	291.591	0.00000	0.00000	97.059
4734	CABLE PLUG	4734	291.527	0.00000	0.00000	97.036
4735	CABLE PLUG	4735	291.321	0.00000	0.00000	96.964
4736	CABLE PLUG	4736	292.396	0.00000	0.00000	97.340
4737	CABLE PLUG	4737	292.568	0.00000	0.00000	97.401
4738	CABLE PLUG	4738	283.622	0.00010	0.00000	94.271
6051	X2 SI Harness	51	245.203	0.00073	0.00000	0.000
6052	X2 SI Harness	52	205.933	0.00073	0.00000	0.000
6053	X2 SI Harness	53	162.824	0.00073	0.00000	0.000
6054	X2 SI Harness	54	113.891	0.00073	0.00000	0.000
6055	X2 SI at HS1	55	50.553	0.00250	0.00000	0.000
6056	X3 SI Harness	56	45.903	0.00250	0.00000	0.000
6057	X3 SI Harness	57	39.539	0.00250	0.00000	0.000
6058	X3 SI Harness	58	30.392	0.00250	0.00000	0.000
6061	X2 JF Harness	61	246.339	0.00010	0.00000	0.000
6062	X2 JF Harness	62	205.932	0.00010	0.00000	0.000
6063	X2 JF Harness	63	161.456	0.00010	0.00000	0.000
6064	X2 JF Harness	64	110.710	0.00010	0.00000	0.000
6065	X2 JF at HS1	65	42.548	0.00024	0.00000	0.000
6066	X3 JF Harness	66	38.265	0.00024	0.00000	0.000
6067	X3 JF Harness	67	33.338	0.00024	0.00000	0.000
6068	X3 JF Harness	68	27.402	0.00024	0.00000	0.000
9999	AMBIENT		293.000	0.00000	0.00000	0.000

=====

+EQM4:CRYO:V

NODE		LABEL	T	QI	QR	C
201	OSS-TUBE	201	4.200	0.00000	0.00000	0.000
202	BAFFLE LO	202	4.200	0.00000	0.00000	0.000
203	BAFFLE UP	203	4.200	0.00000	0.00000	0.000
204	1ST HS	204	10.510	0.00000	0.00000	0.000
205	2ND HS	205	21.909	0.00000	0.00000	0.000
206	3RD HS +z	206	97.432	0.00000	0.00000	0.000
207	3RD HS -z	207	97.330	0.00000	0.00000	0.000
210	VENT VESSEL	210	209.693	0.00000	0.00000	0.000
212	BAFFLE - 1ST HS	212	4.201	0.00000	0.00000	0.000
251	TANK HE-OUT	251	4.200	0.00000	0.00000	0.000
252	OSS HE-OUT	252	4.200	0.00000	0.00000	0.000
253	BAFFLE LO HE-OUT	253	4.200	0.00000	0.00000	0.000
254	BAFFLE UP HE-OUT	254	4.200	0.00000	0.00000	0.000
255	1ST HS HE-OUT	255	10.510	0.00000	0.00000	0.000
256	2ND HS HE-OUT	256	21.889	0.00000	0.00000	0.000
257	3RD HS HE-OUT	257	97.381	0.00000	0.00000	0.000
260	VESSEL HE-OUT	260	209.693	0.00000	0.00000	0.000
262	BAF - HS1 HE-OUT	262	4.200	0.00000	0.00000	0.000
296	HEATER WALL	296	293.000	0.00000	0.00000	0.000
297	HEATER HE-OUT	297	209.693	0.00000	0.00000	0.000

=====

+EQM4:CRYO:PLM

NODE	LABEL	T	QI	QR	C
310	Instr. Shield Cyl.	12.837	0.00000	0.00000	10.589
311	Instr. Shield Top	12.846	0.00000	0.00000	13.694
315	Instr. Shield Baffle	12.860	0.00000	0.00000	0.883
320	Vline wall Tank-PACS	1.793	0.00000	0.00000	0.007
321	Vline wall PACS I/F 1	2.652	0.00000	0.00000	0.001
322	Vline wall PACS I/F 1	2.970	0.00000	0.00000	0.000
323	Vline wall PACS I/F 1	2.792	0.00000	0.00000	0.001
324	Vline wall PACSI/F1/2	2.630	0.00000	0.00000	0.003
325	Vline wall PACSI/F1/2	2.686	0.00000	0.00000	0.016
326	Vline wall PACS I/F 2	3.098	0.00000	0.00000	0.001
327	Vline wall PACS I/F 2	3.262	0.00000	0.00000	0.000
328	Vline wall PACS I/F 2	3.185	0.00000	0.00000	0.001
329	Vline wall PACSI/F2/3	3.126	0.00000	0.00000	0.007
330	Vline wall PACSI/F2/3	3.192	0.00000	0.00000	0.003
331	Vline wall PACS I/F 3	3.311	0.00000	0.00000	0.001
332	Vline wall PACS I/F 3	3.401	0.00000	0.00000	0.000
333	Vline wall PACS I/F 3	3.370	0.00000	0.00000	0.001
334	Vline wall PACS-SPIRE	3.353	0.00000	0.00000	0.007
335	Vline wall PACS-SPIRE	3.392	0.00000	0.00000	0.009
336	Vline wall PACS-SPIRE	3.635	0.00000	0.00000	0.010
337	Vline wall SPIRE	4.786	0.00000	0.00000	0.002
338	Vline wall SPIRE	5.431	0.00000	0.00000	0.001
339	Vline wall SPIRE	5.201	0.00000	0.00000	0.002
340	Vline wall SPIRE-HIFI	5.057	0.00000	0.00000	0.014
341	Vline wall SPIRE-HIFI	5.081	0.00000	0.00000	0.017
342	Vline wall SPIRE-HIFI	5.272	0.00000	0.00000	0.023
343	Vline wall HIFI	6.555	0.00000	0.00000	0.003
344	Vline wall HIFI	7.165	0.00000	0.00000	0.001
345	Vline wall HIFI	7.570	0.00000	0.00000	0.004
346	Vline Lev.2 OB	11.738	0.00000	0.00000	0.111
347	Vline Lev.2 OB	12.543	0.00000	0.00000	0.277
348	Vline Lev.2 OB	12.610	0.00000	0.00000	0.109
349	Vline Lev.2 OB	12.652	0.00000	0.00000	0.172
350	Vline Lev.2 OB	12.666	0.00000	0.00000	0.101
351	Vline Lev.2 OB	12.665	0.00000	0.00000	0.298
352	Vline Lev.2 OB	12.689	0.00000	0.00000	0.153
371	Opt. Bench +Z	12.618	0.00000	0.00000	10.334
372	Opt. Bench +Z -Y	12.569	0.00000	0.00000	9.463
373	Opt. Bench +Z mid	12.622	0.00000	0.00000	24.244
374	Opt. Bench +Z +Y	12.630	0.00000	0.00000	3.917
375	Opt. Bench -Y	12.671	0.00000	0.00000	17.803
376	Opt. Bench centre	12.653	0.00000	0.00000	42.918
377	Opt. Bench +Y	12.658	0.00000	0.00000	9.449
378	Opt. Bench -Z -Y	12.692	0.00000	0.00000	9.684
379	Opt. Bench -Z mid	12.670	0.00000	0.00000	24.463
380	Opt. Bench -Z +Y	12.671	0.00000	0.00000	3.947
381	Opt. Bench -Z	12.665	0.00000	0.00000	10.426
390	I.Shld HIFI Baf. ext.	12.901	0.00000	0.00000	0.413
391	I.Shld HIFI Baf. int.	12.840	0.00000	0.00000	0.145
411	MLI on OB-Shield side	14.391	0.00000	0.00000	32.744
412	MLI on OB-Shield top	14.395	0.00000	0.00000	42.281
710	PACS-Top Optic	3.527	0.00000	0.00000	2.200
720	PACS-Spectrometer	3.524	0.00003	0.00000	2.488
725	PACS-Collimator	3.521	0.00000	0.00000	2.515
730	PACS-Photometer Optic	3.519	0.00000	0.00000	1.518
735	PACS-Internal	3.525	0.00000	0.00000	2.109
740	PACS-Lump	3.525	0.00000	0.00000	0.000
750	PACS-Chopper	3.529	0.00040	0.00000	0.133

755	PACS-Grating Assy	3.528	0.00100	0.00000	0.906
760	PACS-Red Detector	1.706	0.00000	0.00000	0.230
761	PACS-Red Detect. CRE	3.533	0.00030	0.00000	0.033
765	PACS-Blue Detector	1.732	0.00013	0.00000	0.234
766	PACS-Blue Detect. CRE	3.533	0.00030	0.00000	0.033
770	PACS-Filter Wh. Blue	3.525	0.00004	0.00000	0.154
771	PACS-Filter Wh. Photo	3.519	0.00004	0.00000	0.154
775	PACS-Calib. Source 1	3.528	0.00032	0.00000	0.022
776	PACS-Calib. Source 2	3.530	0.00032	0.00000	0.022
780	PACS-Photometer Housi	3.521	0.00000	0.00000	1.165
781	PACS-Photometer CooPu	1.784	0.00220	0.00000	0.147
791	PACS-STST-Strut 1,1	10.385	0.00000	0.00000	0.398
792	PACS-STST-Strut 4,1	10.382	0.00000	0.00000	0.619
793	PACS-STST-Strut 5,1	10.385	0.00000	0.00000	0.310
794	PACS-Kevlar-Strut Red 1	2.866	0.00000	0.00000	0.015
795	PACS-Kevlar-Strut Blue 1	2.870	0.00000	0.00000	0.015
796	PACS-HarnessRed Det.Intl	3.045	0.00000	0.00000	0.000
797	PACS-HarnessBlueDet.Intl	3.051	0.00000	0.00000	0.000
798	PACS-HarnessBlue1.7->4,1	2.773	0.00000	0.00000	0.000
801	SPIRE PM JFET ENCL	12.698	0.01026	0.00000	14.773
802	SPIRE SM JFET ENCL	12.674	0.00282	0.00000	4.800
803	SPIRE Optical Bench	6.010	0.00000	0.00000	15.030
804	SPIRE RF Filter Box	6.015	0.00428	0.00000	0.735
805	SPIRE Beam St. Mech	6.011	0.00100	0.00000	0.551
806	SPIRE SMECm	6.011	0.00048	0.00000	0.651
807	SPIRE PM calibrator	6.011	0.00002	0.00000	0.000
808	SPIRE SM calibrator	10.277	0.00040	0.00000	0.000
809	SPIRE Shutter	6.010	0.00000	0.00000	0.000
810	SPIRE PM Detector en	1.835	0.00000	0.00000	0.461
811	SPIRE SM Detector en	1.804	0.00000	0.00000	0.274
812	SPIRE PM Detectors	1.753	0.00000	0.00000	0.401
813	SPIRE SM detector	1.753	0.00000	0.00000	0.254
816	SPIRE Cooler Pump	1.892	0.00183	0.00000	0.000
817	SPIRE Cooler shunt	1.731	0.00000	0.00000	0.000
818	SPIRE Cooler evap	1.753	0.00000	0.00000	0.000
819	SPIRE Cooler pump HS	1.779	0.00008	0.00000	0.000
820	SPIRE Cooler evap HS	1.731	0.00000	0.00000	0.000
900	HIFI 2K level	1.898	0.00014	0.00000	0.030
905	HIFI Harness 1 int.point	6.759	0.00036	0.00000	0.000
910	HIFI FPU Structure	12.683	0.01602	0.00000	139.753
912	HIFI L0 boundary node	1.888	0.00000	0.00000	0.000
913	HIFI L1 boundary node	7.379	0.00000	0.00000	0.000
914	HIFI Harness 2a int.poin	13.564	0.00036	0.00000	0.000
915	HIFI Harness 2b int.poin	10.392	0.00000	0.00000	0.000
920	HIFI Internal Assy.	7.382	0.00000	0.00000	0.035
5000	GHe tank outlet	1.700	0.00000	0.00000	0.000
5010	GHe PACS I/F 1 in	1.788	0.00000	0.00000	0.000
5011	GHe PACS I/F 1	2.141	0.00000	0.00000	0.000
5012	GHe PACS I/F 1	2.353	0.00000	0.00000	0.000
5013	GHe PACS I/F 1 out	2.547	0.00000	0.00000	0.000
5014	GHe PACS I/F 1/2	2.618	0.00000	0.00000	0.000
5020	GHe PACS I/F 2 in	2.683	0.00000	0.00000	0.000
5021	GHe PACS I/F 2	2.879	0.00000	0.00000	0.000
5022	GHe PACS I/F 2	2.989	0.00000	0.00000	0.000
5023	GHe PACS I/F 2 out	3.085	0.00000	0.00000	0.000
5024	GHe PACS I/F 2/3	3.124	0.00000	0.00000	0.000
5030	GHe PACS I/F 3 in	3.178	0.00000	0.00000	0.000
5031	GHe PACS I/F 3	3.245	0.00000	0.00000	0.000
5032	GHe PACS I/F 3	3.292	0.00000	0.00000	0.000
5033	GHe PACS I/F 3 out	3.332	0.00000	0.00000	0.000
5034	GHe PACS-SPIRE	3.352	0.00000	0.00000	0.000
5035	GHe PACS-SPIRE	3.390	0.00000	0.00000	0.000
5040	GHe SPIRE I/F in	3.623	0.00000	0.00000	0.000

5041	GHe SPIRE I/F	4.296	0.00000	0.00000	0.000
5042	GHe SPIRE I/F	4.716	0.00000	0.00000	0.000
5043	GHe SPIRE I/F out	5.013	0.00000	0.00000	0.000
5044	GHe SPIRE-HIFI	5.055	0.00000	0.00000	0.000
5045	GHe SPIRE-HIFI	5.080	0.00000	0.00000	0.000
5050	GHe HIFI I/F in	5.263	0.00000	0.00000	0.000
5051	GHe HIFI I/F	6.129	0.00000	0.00000	0.000
5052	GHe HIFI I/F	6.583	0.00000	0.00000	0.000
5053	GHe HIFI I/F out	7.293	0.00000	0.00000	0.000
5054	GHe Lev.2 OB	11.517	0.00000	0.00000	0.000
5055	GHe Lev.2 OB	12.492	0.00000	0.00000	0.000
5056	GHe Lev.2 OB	12.604	0.00000	0.00000	0.000
5057	GHe Lev.2 OB	12.649	0.00000	0.00000	0.000
5058	GHe Lev.2 OB	12.665	0.00000	0.00000	0.000
5059	GHe Lev.2 OB	12.665	0.00000	0.00000	0.000
5060	GHe Lev.2 OB	12.688	0.00000	0.00000	0.000
6059	X3 SI Harness 59	13.557	0.00406	0.00000	0.000
6069	X3 JF Harness 69	19.605	0.00040	0.00000	0.000
9999	Ambient Air	293.000	0.00000	0.00000	0.000

+EQM4:CTCE

NODE	LABEL	T	QI	QR	C
901	vessel flange 901	292.340	0.00000	0.00000	905.667
902	vessel flange 902	292.321	0.00000	0.00000	905.651
903	vessel flange 903	292.297	0.00000	0.00000	905.632
904	vessel flange 904	292.260	0.00000	0.00000	905.601
905	vessel flange 905	292.238	0.00000	0.00000	905.583
906	vessel flange 906	292.248	0.00000	0.00000	905.591
907	vessel flange 907	292.306	0.00000	0.00000	905.639
908	vessel flange 908	292.335	0.00000	0.00000	905.663
921	cyl. vessel 921	292.402	0.00000	0.00000	8551.714
922	cyl. vessel 922	292.384	0.00000	0.00000	8551.566
923	cyl. vessel 923	292.335	0.00000	0.00000	8551.181
924	cyl. vessel 924	292.140	0.00000	0.00000	8549.650
925	cyl. vessel 925	292.106	0.00000	0.00000	8549.379
926	cyl. vessel 926	292.141	0.00000	0.00000	8549.657
927	cyl. vessel 927	292.336	0.00000	0.00000	8551.191
928	cyl. vessel 928	292.385	0.00000	0.00000	8551.579
930	vessel dome 930	292.404	0.00000	0.00000	19146.645
1011	Shroud bottom MLI	31.090	0.00000	0.00000	0.000
1012	Shroud bottom MLI	31.054	0.00000	0.00000	0.000
1013	Shroud bottom MLI	34.574	0.00000	0.00000	0.000
1014	Shroud bottom MLI	38.888	0.00000	0.00000	0.000
1015	Shroud bottom MLI	42.625	0.00000	0.00000	0.000
1016	Shroud bottom MLI	45.249	0.00000	0.00000	0.000
1017	Shroud bottom MLI	45.706	0.00000	0.00000	0.000
1018	Shroud bottom MLI	42.427	0.00000	0.00000	0.000
1021	Shroud cyl. MLI	31.090	0.00000	0.00000	0.000
1022	Shroud cyl. MLI	31.054	0.00000	0.00000	0.000
1023	Shroud cyl. MLI	34.574	0.00000	0.00000	0.000
1024	Shroud cyl. MLI	38.888	0.00000	0.00000	0.000
1025	Shroud cyl. MLI	42.625	0.00000	0.00000	0.000
1026	Shroud cyl. MLI	45.249	0.00000	0.00000	0.000
1027	Shroud cyl. MLI	45.706	0.00000	0.00000	0.000
1028	Shroud cyl. MLI	42.427	0.00000	0.00000	0.000
1030	Shroud top MLI	49.195	0.00000	0.00000	0.000
1121	CTA cyl. HS 1121	49.777	0.00000	0.00000	226.528
1122	CTA cyl. HS 1122	49.751	0.00000	0.00000	226.250
1123	CTA cyl. HS 1122	52.822	0.00000	0.00000	259.355
1124	CTA cyl. HS 1122	56.553	0.00000	0.00000	299.560
1125	CTA cyl. HS 1122	59.765	0.00000	0.00000	334.187
1126	CTA cyl. HS 1122	62.038	0.00000	0.00000	359.643
1127	CTA cyl. HS 1122	62.425	0.00000	0.00000	363.997
1128	CTA cyl. HS 1122	59.592	0.00000	0.00000	332.323
1130	CTA top HS 1130	65.197	0.00000	0.00000	587.186
1201	CTA Shroud lo Baf	6.196	0.00000	0.00000	0.178
1211	CTA Shroud up Baf	4.881	0.00000	0.00000	0.101
1221	CTA cy.Shroud 1221	4.511	0.00000	0.00000	0.000
1222	CTA cy.Shroud 1222	4.479	0.00000	0.00000	0.000
1223	CTA cy.Shroud 1223	4.547	0.00000	0.00000	0.000
1224	CTA cy.Shroud 1224	4.559	0.00000	0.00000	0.000
1225	CTA cy.Shroud 1225	4.645	0.00000	0.00000	0.000
1226	CTA cy.Shroud 1226	4.646	0.00000	0.00000	0.000
1227	CTA cy.Shroud 1227	4.715	0.00000	0.00000	0.000
1228	CTA cy.Shroud 1228	4.655	0.00000	0.00000	0.000
1230	CTA topShroud 1230	5.142	0.00000	0.00000	0.696
1240	CTA Reflector	21.075	0.00000	0.00000	32.737
1250	Refl. I/F bracket 1	19.672	0.00000	0.00000	0.000
1252	Refl. I/F br.1 pos.2	168.852	0.00000	0.00000	0.000
1253	Refl. I/F br.1 pos.3	170.212	0.00000	0.00000	0.000

1254	Refl. I/F br.1 pos.4	137.880	0.00000	0.00000	0.000
1255	Refl. I/F br.1 pos.5	140.087	0.00000	0.00000	0.000
1256	Refl. I/F br.1 pos.6	222.619	0.00000	0.00000	0.000
1257	Refl. I/F br.1 pos.7	224.341	0.00000	0.00000	0.000
1260	Refl. I/F bracket 2	22.109	0.00000	0.00000	0.000
1262	Refl. I/F br.2 pos.2	169.578	0.00000	0.00000	0.000
1263	Refl. I/F br.2 pos.3	170.935	0.00000	0.00000	0.000
1264	Refl. I/F br.2 pos.4	138.433	0.00000	0.00000	0.000
1265	Refl. I/F br.2 pos.5	140.630	0.00000	0.00000	0.000
1266	Refl. I/F br.2 pos.6	222.816	0.00000	0.00000	0.000
1267	Refl. I/F br.2 pos.7	224.532	0.00000	0.00000	0.000
1270	Refl. I/F bracket 3	24.617	0.00000	0.00000	0.000
1272	Refl. I/F br.3 pos.2	169.838	0.00000	0.00000	0.000
1273	Refl. I/F br.3 pos.3	171.186	0.00000	0.00000	0.000
1274	Refl. I/F br.3 pos.4	139.175	0.00000	0.00000	0.000
1275	Refl. I/F br.3 pos.5	141.358	0.00000	0.00000	0.000
1276	Refl. I/F br.3 pos.6	223.129	0.00000	0.00000	0.000
1277	Refl. I/F br.3 pos.7	224.837	0.00000	0.00000	0.000
1311	CTA HS bottom MLI	268.518	0.00000	0.00000	0.000
1312	CTA HS bottom MLI	268.503	0.00000	0.00000	0.000
1313	CTA HS bottom MLI	268.499	0.00000	0.00000	0.000
1314	CTA HS bottom MLI	268.494	0.00000	0.00000	0.000
1315	CTA HS bottom MLI	268.496	0.00000	0.00000	0.000
1316	CTA HS bottom MLI	268.518	0.00000	0.00000	0.000
1317	CTA HS bottom MLI	268.559	0.00000	0.00000	0.000
1318	CTA HS bottom MLI	268.565	0.00000	0.00000	0.000
1321	CTA HS cyl. MLI	268.789	0.00000	0.00000	0.000
1322	CTA HS cyl. MLI	268.772	0.00000	0.00000	0.000
1323	CTA HS cyl. MLI	268.741	0.00000	0.00000	0.000
1324	CTA HS cyl. MLI	268.580	0.00000	0.00000	0.000
1325	CTA HS cyl. MLI	268.566	0.00000	0.00000	0.000
1326	CTA HS cyl. MLI	268.612	0.00000	0.00000	0.000
1327	CTA HS cyl. MLI	268.795	0.00000	0.00000	0.000
1328	CTA HS cyl. MLI	268.823	0.00000	0.00000	0.000
1330	CTA HS top MLI	272.875	0.00000	0.00000	0.000
2000	CTA-Shroud Dewar	4.200	0.00000	0.00000	0.000
2001	GHe Shroud 1221 out	4.252	0.00000	0.00000	0.000
2002	GHe Shroud 1222 out	4.291	0.00000	0.00000	0.000
2003	GHe Shroud 1223 out	4.334	0.00000	0.00000	0.000
2004	GHe Shroud 1224 out	4.373	0.00000	0.00000	0.000
2005	GHe Shroud 1225 out	4.419	0.00000	0.00000	0.000
2006	GHe Shroud 1226 out	4.458	0.00000	0.00000	0.000
2007	GHe Shroud 1227 out	4.503	0.00000	0.00000	0.000
2008	GHe Shroud 1228 out	4.529	0.00000	0.00000	0.000
2011	GHe HS 1121 out	29.692	0.00000	0.00000	0.000
2012	GHe HS 1122 out	38.875	0.00000	0.00000	0.000
2013	GHe HS 1123 out	45.597	0.00000	0.00000	0.000
2014	GHe HS 1124 out	51.064	0.00000	0.00000	0.000
2015	GHe HS 1125 out	55.502	0.00000	0.00000	0.000
2016	GHe HS 1126 out	58.889	0.00000	0.00000	0.000
2017	GHe HS 1127 out	60.735	0.00000	0.00000	0.000
2018	GHe HS 1128 out	60.142	0.00000	0.00000	0.000
2021	GHe I/F bracket 1250 out	7.886	0.00000	0.00000	0.000
2022	GHe I/F bracket 1260 out	11.238	0.00000	0.00000	0.000
2023	GHe I/F bracket 1270 out	14.572	0.00000	0.00000	0.000
9999	AMBIENT	293.000	0.00000	0.00000	0.000

Heat Balance for PAYLOAD incl. Instrument Shield MLI

=====

Level 0: from Aux. Tank into instruments	-19.444 [mW]
Level 2: from spatial framework into OB	-6.564 [mW]
Level 1/2: from Aux. Tank into OB via ventline wall	-0.108 [mW]
Level 2: from HS1 into OB via ventline wall	0.114 [mW]
Level 2: via harness into OB	26.688 [mW]
via radiation from HS1 upper bulkhead onto Instrument MLI	0.170 [mW]
via radiation from Cryostat cavity onto OB lower side	5.090 [mW]
via radiation from HS1-baffle into payload	0.006 [mW]
via radiation from HS2-baffle into payload	0.023 [mW]
via radiation from HS3-baffle into payload	1.505 [mW]
via radiation from CTCE-4K-shrouds into payload	-0.023 [mW]
via radiation from CTCE lower-shroud baffle into payload	-0.003 [mW]
via radiation from CTCE upper-shroud baffle into payload	-0.003 [mW]
via radiation from CTCE reflector into payload	0.010 [mW]
via radiation from CVV-LOU-Window onto HIFI-Baffle	19.948 [mW]
via radiation from CVV-LOU-Window onto HIFI-FPU	14.512 [mW]
Vent line cooling power (out of payload)	89.539 [mW]
Transferred by convection from PL-ventline on helium	89.615 [mW]
total dissipation of PACS	5.070 [mW]
total dissipation of SPIRE	21.167 [mW]
total dissipation of HIFI	16.867 [mW]
Harness dissipation on OB	4.462 [mW]
Payload Heat Imbalance (shall be 0)	-0.052 [mW]

Heat Balance for Main Tank Ventline

=====

conducted and radiated into ventline attached to HS1	3205.572 [mW]
conducted and radiated into ventline attached to HS2	5781.441 [mW]
conducted and radiated into ventline attached to HS3 +Z	19190.511 [mW]
conducted and radiated into ventline attached to HS3 -Z	19164.532 [mW]
conducted into ventline walls from CVV	57061.522 [mW]
conducted and radiated into line baf to HS 1	0.151 [mW]
Main Tank Ventline cooling power (out of ventline)	104403.846 [mW]
Via convection into ventline walls	-104413.886 [mW]
Main Tank Ventline Imbalance (shall be 0)	-0.117 [mW]

Heat Balance for CTCE

=====

Convective heat transfer onto CTCE-external insulation	27237.430 [mW]
Conducted from CVV into CTCE-structure	-277.187 [mW]
Radiated from Payload into CTCE-shrouds incl. baffles	0.029 [mW]
Radiated from HS-baffles onto CTCE-shroud	48.698 [mW]
Radiated from CVV flange disc within cavity onto CTCE-MLI	2061.674 [mW]
Radiated from Payload onto reflector	-0.010 [mW]
Conducted from CTCE-structure into CTCE-shrouds	0.000 [mW]
Cooling power of CTCE-shrouds	29070.640 [mW]
CTCE Imbalance (shall be 0)	-0.006 [mW]

Heat Balance for Reflector within CTCE

=====

via struts from CTCE-I/F brackets into reflector	0.120 [mW]
by radiation from CTCE-shrouds into reflector	-0.114 [mW]
by radiation from Payload into reflector	-0.010 [mW]
reflector heater power	0.000 [mW]
reflector total imbalance (shall be 0)	-0.004 [mW]

Heat Balance for whole Cryostat including Payload, Ventlines and CTCE

Convective heat transfer onto external walls	133411.506	[mW]
total heat transferred on gaseous helium	133564.025	[mW]
evaporation power in main and aux. tank	2081.064	[mW]
Total instrument power dissipation	43.104	[mW]
total main & auxiliary tank and reflector heater power	2000.000	[mW]
heater power of CVV lower bulkhead HTR	0.000	[mW]
total harness dissipation within system	19.601	[mW]
Cooling power of CTCE-shrouds	29070.640	[mW]
Cryostat total imbalance (shall be 0)	-170.878	[mW]

Heat Balance for Main Tank

Main tank dissipation + heater power	2000.000	[mW]
heat from Aux. tank via mech. I/F	-0.451	[mW]
radiated from aux. tank	0.000	[mW]
conducted from spatial framework	35.657	[mW]
transferred through MLI	9.755	[mW]
conducted from rest	0.290	[mW]
radiated from spatial framework and HSs	0.076	[mW]
conducted from main tank ventline wall	0.000	[mW]
radiated from payload	0.000	[mW]
total heat into main tank	2045.327	[mW]

Heat Balance for Auxiliary Tank

Aux. tank dissipation + heater power	0.000	[mW]
heat from Main tank via mech. I/F	0.451	[mW]
radiated from Main tank	0.000	[mW]
radiated from spatial framework and HSs	0.015	[mW]
conducted from payload L0	19.444	[mW]
conducted from payload L2	0.108	[mW]
radiated from payload	0.019	[mW]
conducted from filling tube	0.007	[mW]
radiated from MLI filling tube	15.692	[mW]
total heat into Aux. tank	35.737	[mW]

Heat flows into Tanks

Into Main Tank	2045.327	[mW]
Into Aux. Tank	35.737	[mW]

Helium evaporation mass flow rates

Out of Main Tank	97.769	[mg/s]
Out of Aux. Tank	1.568	[mg/s]
Out of external He- dewar for CTA-shroud cooling	100.000	[mg/s]

5.2 CTCE-Design-1 Case 2

CTCE-design1 means: MLI-design concept for CTCE as defined in § 4.5.2.1

Case 2 means: EQM-aux. Tank heater power = 14 mW

The input parameters are compiled in Table 5-5 and a brief temperature results summary is given in Table 5-7. The complete ESATAN-output-file listing is appended. The respective node numbers and labels are referenced in the thermal design and thermal-mathematical model descriptions in § 4

Input parameter	
Main Tank temperature	4.2 K
EQM-aux. Tank temperature	1.7 K
External Hel dewar temp. for CTCE-shroud cooling	4.2 K
Main Tank heater power	2000 mW
EQM-auxiliary tank heater power	14 mW
CTCE-shroud He-mass flow rate	100 mg/s
Reflector heater power	0 mW

Table 5-5: Input parameters

Submodel	Node #	Node Label	T (K)	T _{max} (K) required	Require ment fulfilled
CRYO	12, 22, 32	Heatshield 1	10 – 16	NA	NA
CRYO	13, 23, 33	Heatshield 2	22 – 38	NA	NA
CRYO	14, 15, 24, 25, 34, 35	Heatshield 3	98 – 143	NA	NA
CRYO	4001 - 4078	CVV	293	NA	NA
CRYO	4090	LOU window	290	NA	NA
CRYO:PLM	371 - 381	Optical Bench	11 – 12	15	yes

Submodel	Node #	Node Label	T (K)	T _{max} (K) required	Requirement fulfilled
CRYO:PLM	811	SPIRE SM Detector enclosure	1.78	1.8	yes
CRYO:PLM	819	SPIRE Cooler Pump HS	1.77	1.8	yes
CRYO:PLM	820	SPIRE Cooler Evaporator HS	1.73	1.8	yes
CRYO:PLM	765	PACS Blue Detector	1.72	3.5	yes
CRYO:PLM	760	PACS Red Detector	1.70	1.75	yes
CRYO:PLM	781	PACS He-Pump	1.78	2.20	yes
CRYO:PLM	912	HIFI I0-Boundary	1.85	2.00	yes
CRYO:PLM	803	SPIRE Optical Bench	5.3	4.5	No 1)
CRYO:PLM	730	PACS Photometer Optics	3.2	5	yes
CRYO:PLM	725	PACS Collimator	3.2	5	yes
CRYO:PLM	720	PACS Spectrom. Housing	3.2	5	yes
CRYO:PLM	913	HIFI L1-interface	6.1	6	No 2)
CRYO:PLM	801	SPIRE PM JFET enclosure	12	13	yes
CRYO:PLM	802	SPIRE SM JFET enclosure	12	13	yes
CRYO:PLM	910	HIFI FPU Structure	12	13	yes
CTCE	901 -930	CTCE vessel	292	NA	NA
CTCE	1221 - 1230	CTA-shroud	4.5 – 5.1	5	yes
CTCE	1121 – 1130	CTA- heatshield	50 – 65	NA	NA
CTCE	1240	CTA-Reflector	21	40 -80	No *)
CTCE	1250, 1260, 1270	Reflector interface brackets (or optical bench)	20 - 25	NA	NA
		Mass-flow rate (mg/s)	required mass-flow rate (mg/s)	Requirement fulfilled	
Out of main tank		98	NA**)	NA	
Out of EQM-auxiliary tank		2.0	2.1	yes	
Out of external He-dewar for CTA-shroud cooling		100	NA **)	NA	

1) requirement not yet approved by ASED

2) can be fulfilled b slightly increasing the mass flow rate to 2.1 mg/s.

*) temperature can easily be increased by electrically heating

**) to be verified whether pressure drop is not too high

***) can easily be increased by electrical heating

Table 5-7: Brief results summary

EUROPEAN SPACE AGENCY THERMAL ANALYSIS NETWORK
 (VERSION 8.5.0) PAGE 1 14 FEBRUARY 2002
 14:18:57 EQM4

```
#####
#
# Main Tank heater power:      2000 mW
# Aux. Tank heater power:     14 mW
# CTCE-shroud mass flow rate: 100 mg/s
# Reflector HTR power:        0 mW
#
#####
```

+EQM4:CRYO

NODE	LABEL	T	QI	QR	C
1	MAIN TANK	4.200	0.00000	2.00000	0.000
2	AUX TANK	1.700	0.00000	0.01400	0.000
5	Ti-head lo 5	11.290	0.00000	0.00000	71.111
6	belt fitting lo 6	10.681	0.00000	0.00000	63.280
7	strut tank end lo 7	4.359	0.00000	0.00000	21.852
8	Ti-head up 8	11.317	0.00000	0.00000	71.335
9	belt fitting up 9	10.708	0.00000	0.00000	63.499
10	strut tank end up 10	4.360	0.00000	0.00000	21.858
12	HS 1 BULK 12	10.597	0.00000	0.00000	14.056
13	HS 2 BULK 13	22.984	0.00000	0.00000	140.213
14	HS 3 BULK +Z 14	119.584	0.00000	0.00000	2768.515
15	HS 3 BULK -Z 15	119.551	0.00000	0.00000	2767.874
22	HS 1 CYL 22	10.523	0.00000	0.00000	44.749
23	HS 2 CYL 23	21.971	0.00000	0.00000	330.815
24	HS 3 CYL +Z 24	97.636	0.00000	0.00000	6861.636
25	HS 3 CYL -Z 25	97.534	0.00000	0.00000	6852.337
32	HS 1 CONE 32	15.545	0.00000	0.00000	91.935
33	HS 2 CONE 33	38.010	0.00000	0.00000	1511.225
34	HS 3 CONE +Z 34	142.349	0.00000	0.00000	7729.252
35	HS 3 CONE -Z 35	142.555	0.00000	0.00000	7729.252
42	HS 1 HIFI Baf. int.	25.657	0.00000	0.00000	2.933
52	HS 1 HIFI Baf. ext.	32.990	0.00000	0.00000	2.678
53	HS 2 HIFI Baf.	57.606	0.00000	0.00000	10.633
54	HS 3 HIFI Baf.	175.289	0.00000	0.00000	45.571
62	HS 1 Tele BAF	15.572	0.00000	0.00000	0.347
63	HS 2 Tele BAF	38.197	0.00000	0.00000	5.548
64	HS 3 Tele BAF	142.255	0.00000	0.00000	81.113
101	MLI MAIN TANK LO 101	5.168	0.00000	0.00000	15.689
105	MLI MAIN TANK CY 105	4.735	0.00000	0.00000	43.340
106	MLI MAIN TANK UP 106	37.069	0.00000	0.00000	112.532
112	MLI HS 1 BULK 112	20.330	0.00000	0.00000	39.960
113	MLI HS 2 BULK 113	115.138	0.00000	0.00000	382.065
114	MLI HS 3 BULK +Z 114	287.452	0.00000	0.00000	706.440
115	MLI HS 3 BULK -Z 115	287.428	0.00000	0.00000	706.381
122	MLI HS 1 CYL 122	19.263	0.00000	0.00000	123.049
123	MLI HS 2 CYL 123	93.766	0.00000	0.00000	969.535
124	MLI HS 3 CYL +Z 124	286.653	0.00000	0.00000	2100.824
125	MLI HS 3 CYL -Z 125	285.595	0.00000	0.00000	2093.073
132	MLI HS 1 CONE 132	51.504	0.00000	0.00000	249.841
133	MLI HS 2 CONE 133	137.835	0.00000	0.00000	1125.916
134	MLI HS 3 CONE +Z 134	287.294	0.00000	0.00000	1702.067
135	MLI HS 3 CONE -Z 135	287.274	0.00000	0.00000	1701.948
440	filling tube 440	271.528	0.00000	0.00000	0.000

441	filling tube	441	252.225	0.00000	0.00000	0.000
442	filling tube	442	245.520	0.00000	0.00000	0.000
443	filling tube	443	242.460	0.00000	0.00000	0.000
447	empty tube	447	15.532	0.00000	0.00000	0.000
452	empty tube	452	10.866	0.00000	0.00000	0.000
502	line baf to HS1	502	4.201	0.00000	0.00000	0.000
642	MLI filling tube	642	120.439	0.00000	0.00000	0.766
643	MLI filling tube	643	119.021	0.00000	0.00000	0.743
647	MLI filling tube	647	25.816	0.00000	0.00000	1.245
652	MLI filling tube	652	23.550	0.00000	0.00000	0.459
1000	HS 1 SUSP BOLT	1000	19.629	0.00000	0.00000	0.000
2000	HS 2 SUSP BOLT	2000	67.893	0.00000	0.00000	0.000
3000	HS 3 SUSP BOLT	3000	189.811	0.00000	0.00000	0.000
4001	CVV lower bulk	4001	292.764	0.00000	0.00000	4399.464
4002	CVV lower bulk	4002	292.771	0.00000	0.00000	4399.491
4003	CVV lower bulk	4003	292.771	0.00000	0.00000	4399.491
4004	CVV lower bulk	4004	292.764	0.00000	0.00000	4399.462
4005	CVV lower bulk	4005	292.750	0.00000	0.00000	4399.407
4006	CVV lower bulk	4006	292.749	0.00000	0.00000	4399.404
4007	CVV lower bulk	4007	292.759	0.00000	0.00000	4399.442
4008	CVV lower bulk	4008	292.760	0.00000	0.00000	4399.449
4011	CVV lower bulk	4011	292.707	0.00000	0.00000	1668.975
4012	CVV lower bulk	4012	292.740	0.00000	0.00000	1669.026
4013	CVV lower bulk	4013	292.741	0.00000	0.00000	1669.028
4014	CVV lower bulk	4014	292.717	0.00000	0.00000	1668.991
4015	CVV lower bulk	4015	292.654	0.00000	0.00000	1668.893
4016	CVV lower bulk	4016	292.654	0.00000	0.00000	1668.894
4017	CVV lower bulk	4017	292.705	0.00000	0.00000	1668.971
4018	CVV lower bulk	4018	292.700	0.00000	0.00000	1668.964
4031	CVV cyl lower	4031	292.553	0.00000	0.00000	13706.679
4032	CVV cyl lower	4032	292.661	0.00000	0.00000	13708.039
4033	CVV cyl lower	4033	292.663	0.00000	0.00000	13708.075
4034	CVV cyl lower	4034	292.599	0.00000	0.00000	13707.263
4035	CVV cyl lower	4035	292.392	0.00000	0.00000	13704.653
4036	CVV cyl lower	4036	292.397	0.00000	0.00000	13704.712
4037	CVV cyl lower	4037	292.569	0.00000	0.00000	13706.878
4038	CVV cyl lower	4038	292.537	0.00000	0.00000	13706.479
4041	CVV cyl upper	4041	292.694	0.00000	0.00000	19514.609
4042	CVV cyl upper	4042	292.699	0.00000	0.00000	19514.697
4043	CVV cyl upper	4043	292.633	0.00000	0.00000	19513.515
4044	CVV cyl upper	4044	292.216	0.00000	0.00000	19506.024
4045	CVV cyl upper	4045	289.662	0.00000	0.00000	19460.131
4046	CVV cyl upper	4046	289.657	0.00000	0.00000	19460.035
4047	CVV cyl upper	4047	292.187	0.00000	0.00000	19505.494
4048	CVV cyl upper	4048	292.604	0.00000	0.00000	19512.981
4051	CVV upper bulk	4051	292.714	0.00000	0.00000	19050.968
4052	CVV upper bulk	4052	292.627	0.00000	0.00000	19049.443
4053	CVV upper bulk	4053	292.618	0.00000	0.00000	19049.279
4054	CVV upper bulk	4054	292.670	0.00000	0.00000	19050.189
4055	CVV upper bulk	4055	292.589	0.00000	0.00000	19048.780
4056	CVV upper bulk	4056	292.545	0.00000	0.00000	19048.003
4057	CVV upper bulk	4057	292.681	0.00000	0.00000	19050.386
4058	CVV upper bulk	4058	292.719	0.00000	0.00000	19051.064
4061	CVV/CTA flange	4061	292.330	0.00000	0.00000	0.000
4062	CVV/CTA flange	4062	292.307	0.00000	0.00000	0.000
4063	CVV/CTA flange	4063	292.286	0.00000	0.00000	0.000
4064	CVV/CTA flange	4064	292.263	0.00000	0.00000	0.000
4065	CVV/CTA flange	4065	292.240	0.00000	0.00000	0.000
4066	CVV/CTA flange	4066	292.244	0.00000	0.00000	0.000
4067	CVV/CTA flange	4067	292.299	0.00000	0.00000	0.000
4068	CVV/CTA flange	4068	292.326	0.00000	0.00000	0.000
4071	CVV flange disc	4071	292.174	0.00000	0.00000	0.000
4072	CVV flange disc	4072	292.162	0.00000	0.00000	0.000

4073	CVV flange disc	4073	292.144	0.00000	0.00000	0.000
4074	CVV flange disc	4074	292.126	0.00000	0.00000	0.000
4075	CVV flange disc	4075	292.114	0.00000	0.00000	0.000
4076	CVV flange disc	4076	292.121	0.00000	0.00000	0.000
4077	CVV flange disc	4077	292.150	0.00000	0.00000	0.000
4078	CVV flange disc	4078	292.171	0.00000	0.00000	0.000
4090	CVV Lo window		289.929	0.00000	0.00000	15.604
4631	SUSP TI lo	4631	282.781	0.00000	0.00000	84.266
4632	SUSP TI lo	4632	282.880	0.00000	0.00000	84.277
4633	SUSP TI lo	4633	282.883	0.00000	0.00000	84.277
4634	SUSP TI lo	4634	282.824	0.00000	0.00000	84.271
4635	SUSP TI lo	4635	282.633	0.00000	0.00000	84.250
4636	SUSP TI lo	4636	282.638	0.00000	0.00000	84.251
4637	SUSP TI lo	4637	282.795	0.00000	0.00000	84.268
4638	SUSP TI lo	4638	282.766	0.00000	0.00000	84.265
4641	SUSP TI up	4641	282.911	0.00000	0.00000	84.280
4642	SUSP TI up	4642	282.916	0.00000	0.00000	84.281
4643	SUSP TI up	4643	282.855	0.00000	0.00000	84.274
4644	SUSP TI up	4644	282.471	0.00000	0.00000	84.233
4645	SUSP TI up	4645	280.122	0.00000	0.00000	83.983
4646	SUSP TI up	4646	280.118	0.00000	0.00000	83.983
4647	SUSP TI up	4647	282.444	0.00000	0.00000	84.230
4648	SUSP TI up	4648	282.828	0.00000	0.00000	84.271
4731	CABLE PLUG	4731	281.499	0.00073	0.00000	93.529
4732	CABLE PLUG	4732	291.588	0.00000	0.00000	97.058
4733	CABLE PLUG	4733	291.591	0.00000	0.00000	97.059
4734	CABLE PLUG	4734	291.527	0.00000	0.00000	97.036
4735	CABLE PLUG	4735	291.321	0.00000	0.00000	96.964
4736	CABLE PLUG	4736	292.397	0.00000	0.00000	97.341
4737	CABLE PLUG	4737	292.569	0.00000	0.00000	97.401
4738	CABLE PLUG	4738	283.622	0.00010	0.00000	94.272
6051	X2 SI Harness	51	245.203	0.00073	0.00000	0.000
6052	X2 SI Harness	52	205.934	0.00073	0.00000	0.000
6053	X2 SI Harness	53	162.825	0.00073	0.00000	0.000
6054	X2 SI Harness	54	113.892	0.00073	0.00000	0.000
6055	X2 SI at HS1	55	50.556	0.00250	0.00000	0.000
6056	X3 SI Harness	56	45.804	0.00250	0.00000	0.000
6057	X3 SI Harness	57	39.314	0.00250	0.00000	0.000
6058	X3 SI Harness	58	29.953	0.00250	0.00000	0.000
6061	X2 JF Harness	61	246.339	0.00010	0.00000	0.000
6062	X2 JF Harness	62	205.932	0.00010	0.00000	0.000
6063	X2 JF Harness	63	161.456	0.00010	0.00000	0.000
6064	X2 JF Harness	64	110.711	0.00010	0.00000	0.000
6065	X2 JF at HS1	65	42.549	0.00024	0.00000	0.000
6066	X3 JF Harness	66	38.138	0.00024	0.00000	0.000
6067	X3 JF Harness	67	33.046	0.00024	0.00000	0.000
6068	X3 JF Harness	68	26.869	0.00024	0.00000	0.000
9999	AMBIENT		293.000	0.00000	0.00000	0.000

+EQM4:CRYO:V

NODE		LABEL	T	QI	QR	C
201	OSS-TUBE	201	4.200	0.00000	0.00000	0.000
202	BAFFLE LO	202	4.200	0.00000	0.00000	0.000
203	BAFFLE UP	203	4.200	0.00000	0.00000	0.000
204	1ST HS	204	10.523	0.00000	0.00000	0.000
205	2ND HS	205	21.971	0.00000	0.00000	0.000
206	3RD HS +z	206	97.636	0.00000	0.00000	0.000
207	3RD HS -z	207	97.534	0.00000	0.00000	0.000
210	VENT VESSEL	210	209.896	0.00000	0.00000	0.000
212	BAFFLE - 1ST HS	212	4.201	0.00000	0.00000	0.000
251	TANK HE-OUT	251	4.200	0.00000	0.00000	0.000
252	OSS HE-OUT	252	4.200	0.00000	0.00000	0.000
253	BAFFLE LO HE-OUT	253	4.200	0.00000	0.00000	0.000
254	BAFFLE UP HE-OUT	254	4.200	0.00000	0.00000	0.000
255	1ST HS HE-OUT	255	10.523	0.00000	0.00000	0.000
256	2ND HS HE-OUT	256	21.951	0.00000	0.00000	0.000
257	3RD HS HE-OUT	257	97.585	0.00000	0.00000	0.000
260	VESSEL HE-OUT	260	209.896	0.00000	0.00000	0.000
262	BAF - HS1 HE-OUT	262	4.200	0.00000	0.00000	0.000
296	HEATER WALL	296	293.000	0.00000	0.00000	0.000
297	HEATER HE-OUT	297	209.896	0.00000	0.00000	0.000

=====

+EQM4:CRYO:PLM

NODE	LABEL	T	QI	QR	C
310	Instr. Shield Cyl.	11.537	0.00000	0.00000	8.100
311	Instr. Shield Top	11.548	0.00000	0.00000	10.485
315	Instr. Shield Baffle	11.564	0.00000	0.00000	0.677
320	Vline wall Tank-PACS	1.755	0.00000	0.00000	0.007
321	Vline wall PACS I/F 1	2.395	0.00000	0.00000	0.001
322	Vline wall PACS I/F 1	2.641	0.00000	0.00000	0.000
323	Vline wall PACS I/F 1	2.478	0.00000	0.00000	0.001
324	Vline wall PACSI/F1/2	2.309	0.00000	0.00000	0.003
325	Vline wall PACSI/F1/2	2.339	0.00000	0.00000	0.013
326	Vline wall PACS I/F 2	2.709	0.00000	0.00000	0.001
327	Vline wall PACS I/F 2	2.860	0.00000	0.00000	0.000
328	Vline wall PACS I/F 2	2.771	0.00000	0.00000	0.001
329	Vline wall PACSI/F2/3	2.682	0.00000	0.00000	0.006
330	Vline wall PACSI/F2/3	2.747	0.00000	0.00000	0.002
331	Vline wall PACS I/F 3	2.879	0.00000	0.00000	0.001
332	Vline wall PACS I/F 3	2.983	0.00000	0.00000	0.000
333	Vline wall PACS I/F 3	2.936	0.00000	0.00000	0.001
334	Vline wall PACS-SPIRE	2.895	0.00000	0.00000	0.006
335	Vline wall PACS-SPIRE	2.918	0.00000	0.00000	0.007
336	Vline wall PACS-SPIRE	3.080	0.00000	0.00000	0.008
337	Vline wall SPIRE	4.029	0.00000	0.00000	0.001
338	Vline wall SPIRE	4.579	0.00000	0.00000	0.001
339	Vline wall SPIRE	4.325	0.00000	0.00000	0.001
340	Vline wall SPIRE-HIFI	4.118	0.00000	0.00000	0.012
341	Vline wall SPIRE-HIFI	4.131	0.00000	0.00000	0.015
342	Vline wall SPIRE-HIFI	4.239	0.00000	0.00000	0.018
343	Vline wall HIFI	5.181	0.00000	0.00000	0.002
344	Vline wall HIFI	5.734	0.00000	0.00000	0.001
345	Vline wall HIFI	6.042	0.00000	0.00000	0.003
346	Vline Lev.2 OB	10.088	0.00000	0.00000	0.070
347	Vline Lev.2 OB	11.143	0.00000	0.00000	0.203
348	Vline Lev.2 OB	11.258	0.00000	0.00000	0.081
349	Vline Lev.2 OB	11.327	0.00000	0.00000	0.130
350	Vline Lev.2 OB	11.354	0.00000	0.00000	0.076
351	Vline Lev.2 OB	11.358	0.00000	0.00000	0.225
352	Vline Lev.2 OB	11.383	0.00000	0.00000	0.116
371	Opt. Bench +Z	11.274	0.00000	0.00000	7.719
372	Opt. Bench +Z -Y	11.207	0.00000	0.00000	7.014
373	Opt. Bench +Z mid	11.286	0.00000	0.00000	18.149
374	Opt. Bench +Z +Y	11.303	0.00000	0.00000	2.940
375	Opt. Bench -Y	11.353	0.00000	0.00000	13.427
376	Opt. Bench centre	11.335	0.00000	0.00000	32.336
377	Opt. Bench +Y	11.340	0.00000	0.00000	7.122
378	Opt. Bench -Z -Y	11.386	0.00000	0.00000	7.336
379	Opt. Bench -Z mid	11.362	0.00000	0.00000	18.496
380	Opt. Bench -Z +Y	11.364	0.00000	0.00000	2.985
381	Opt. Bench -Z	11.359	0.00000	0.00000	7.884
390	I.Shld HIFI Baf. ext.	11.611	0.00000	0.00000	0.318
391	I.Shld HIFI Baf. int.	11.541	0.00000	0.00000	0.111
411	MLI on OB-Shield side	13.890	0.00000	0.00000	31.603
412	MLI on OB-Shield top	13.894	0.00000	0.00000	40.809
710	PACS-Top Optic	3.159	0.00000	0.00000	1.888
720	PACS-Spectrometer	3.156	0.00003	0.00000	2.135
725	PACS-Collimator	3.154	0.00000	0.00000	2.159
730	PACS-Photometer Optic	3.153	0.00000	0.00000	1.304
735	PACS-Internal	3.158	0.00000	0.00000	1.811
740	PACS-Lump	3.157	0.00000	0.00000	0.000
750	PACS-Chopper	3.162	0.00040	0.00000	0.114

755	PACS-Grating Assy	3.161	0.00100	0.00000	0.778
760	PACS-Red Detector	1.704	0.00000	0.00000	0.230
761	PACS-Red Detect. CRE	3.168	0.00030	0.00000	0.029
765	PACS-Blue Detector	1.723	0.00013	0.00000	0.233
766	PACS-Blue Detect. CRE	3.168	0.00030	0.00000	0.029
770	PACS-Filter Wh. Blue	3.157	0.00004	0.00000	0.133
771	PACS-Filter Wh. Photo	3.153	0.00004	0.00000	0.132
775	PACS-Calib. Source 1	3.160	0.00032	0.00000	0.019
776	PACS-Calib. Source 2	3.162	0.00032	0.00000	0.019
780	PACS-Photometer Housi	3.155	0.00000	0.00000	1.001
781	PACS-Photometer CooPu	1.781	0.00220	0.00000	0.147
791	PACS-STST-Strut 1,1	9.169	0.00000	0.00000	0.326
792	PACS-STST-Strut 4,1	9.165	0.00000	0.00000	0.507
793	PACS-STST-Strut 5,1	9.169	0.00000	0.00000	0.254
794	PACS-Kevlar-Strut Red 1	2.614	0.00000	0.00000	0.014
795	PACS-Kevlar-Strut Blue 1	2.618	0.00000	0.00000	0.014
796	PACS-HarnessRed Det.Intl	2.549	0.00000	0.00000	0.000
797	PACS-HarnessBlueDet.Intl	2.556	0.00000	0.00000	0.000
798	PACS-HarnessBlue1.7->4,1	2.540	0.00000	0.00000	0.000
801	SPIRE PM JFET ENCL	11.393	0.01026	0.00000	11.194
802	SPIRE SM JFET ENCL	11.367	0.00282	0.00000	3.631
803	SPIRE Optical Bench	5.194	0.00000	0.00000	10.163
804	SPIRE RF Filter Box	5.198	0.00428	0.00000	0.498
805	SPIRE Beam St. Mech	5.195	0.00100	0.00000	0.373
806	SPIRE SMECm	5.194	0.00048	0.00000	0.441
807	SPIRE PM calibrator	5.195	0.00002	0.00000	0.000
808	SPIRE SM calibrator	9.460	0.00040	0.00000	0.000
809	SPIRE Shutter	5.194	0.00000	0.00000	0.000
810	SPIRE PM Detector en	1.799	0.00000	0.00000	0.452
811	SPIRE SM Detector en	1.776	0.00000	0.00000	0.269
812	SPIRE PM Detectors	1.742	0.00000	0.00000	0.398
813	SPIRE SM detector	1.742	0.00000	0.00000	0.252
816	SPIRE Cooler Pump	1.887	0.00183	0.00000	0.000
817	SPIRE Cooler shunt	1.725	0.00000	0.00000	0.000
818	SPIRE Cooler evap	1.742	0.00000	0.00000	0.000
819	SPIRE Cooler pump HS	1.774	0.00008	0.00000	0.000
820	SPIRE Cooler evap HS	1.725	0.00000	0.00000	0.000
900	HIFI 2K level	1.859	0.00014	0.00000	0.030
905	HIFI Harness 1 int.point	6.029	0.00036	0.00000	0.000
910	HIFI FPU Structure	11.366	0.01602	0.00000	105.524
912	HIFI L0 boundary node	1.852	0.00000	0.00000	0.000
913	HIFI L1 boundary node	5.991	0.00000	0.00000	0.000
914	HIFI Harness 2a int.poin	12.664	0.00036	0.00000	0.000
915	HIFI Harness 2b int.poin	9.077	0.00000	0.00000	0.000
920	HIFI Internal Assy.	5.995	0.00000	0.00000	0.025
5000	GHe tank outlet	1.700	0.00000	0.00000	0.000
5010	GHe PACS I/F 1 in	1.752	0.00000	0.00000	0.000
5011	GHe PACS I/F 1	1.967	0.00000	0.00000	0.000
5012	GHe PACS I/F 1	2.104	0.00000	0.00000	0.000
5013	GHe PACS I/F 1 out	2.236	0.00000	0.00000	0.000
5014	GHe PACS I/F 1/2	2.290	0.00000	0.00000	0.000
5020	GHe PACS I/F 2 in	2.336	0.00000	0.00000	0.000
5021	GHe PACS I/F 2	2.476	0.00000	0.00000	0.000
5022	GHe PACS I/F 2	2.562	0.00000	0.00000	0.000
5023	GHe PACS I/F 2 out	2.642	0.00000	0.00000	0.000
5024	GHe PACS I/F 2/3	2.678	0.00000	0.00000	0.000
5030	GHe PACS I/F 3 in	2.724	0.00000	0.00000	0.000
5031	GHe PACS I/F 3	2.786	0.00000	0.00000	0.000
5032	GHe PACS I/F 3	2.832	0.00000	0.00000	0.000
5033	GHe PACS I/F 3 out	2.874	0.00000	0.00000	0.000
5034	GHe PACS-SPIRE	2.893	0.00000	0.00000	0.000
5035	GHe PACS-SPIRE	2.917	0.00000	0.00000	0.000
5040	GHe SPIRE I/F in	3.072	0.00000	0.00000	0.000

5041	GHe SPIRE I/F	3.520	0.00000	0.00000	0.000
5042	GHe SPIRE I/F	3.826	0.00000	0.00000	0.000
5043	GHe SPIRE I/F out	4.072	0.00000	0.00000	0.000
5044	GHe SPIRE-HIFI	4.115	0.00000	0.00000	0.000
5045	GHe SPIRE-HIFI	4.131	0.00000	0.00000	0.000
5050	GHe HIFI I/F in	4.234	0.00000	0.00000	0.000
5051	GHe HIFI I/F	4.735	0.00000	0.00000	0.000
5052	GHe HIFI I/F	5.064	0.00000	0.00000	0.000
5053	GHe HIFI I/F out	5.624	0.00000	0.00000	0.000
5054	GHe Lev.2 OB	9.865	0.00000	0.00000	0.000
5055	GHe Lev.2 OB	11.079	0.00000	0.00000	0.000
5056	GHe Lev.2 OB	11.249	0.00000	0.00000	0.000
5057	GHe Lev.2 OB	11.323	0.00000	0.00000	0.000
5058	GHe Lev.2 OB	11.352	0.00000	0.00000	0.000
5059	GHe Lev.2 OB	11.358	0.00000	0.00000	0.000
5060	GHe Lev.2 OB	11.382	0.00000	0.00000	0.000
6059	X3 SI Harness 59	12.220	0.00406	0.00000	0.000
6069	X3 JF Harness 69	18.609	0.00040	0.00000	0.000
9999	Ambient Air	293.000	0.00000	0.00000	0.000

+EQM4:CTCE

NODE	LABEL	T	QI	QR	C
901	vessel flange 901	292.340	0.00000	0.00000	905.667
902	vessel flange 902	292.321	0.00000	0.00000	905.651
903	vessel flange 903	292.297	0.00000	0.00000	905.632
904	vessel flange 904	292.260	0.00000	0.00000	905.601
905	vessel flange 905	292.239	0.00000	0.00000	905.583
906	vessel flange 906	292.248	0.00000	0.00000	905.591
907	vessel flange 907	292.306	0.00000	0.00000	905.639
908	vessel flange 908	292.335	0.00000	0.00000	905.663
921	cyl. vessel 921	292.402	0.00000	0.00000	8551.714
922	cyl. vessel 922	292.384	0.00000	0.00000	8551.566
923	cyl. vessel 923	292.335	0.00000	0.00000	8551.181
924	cyl. vessel 924	292.140	0.00000	0.00000	8549.650
925	cyl. vessel 925	292.106	0.00000	0.00000	8549.379
926	cyl. vessel 926	292.141	0.00000	0.00000	8549.657
927	cyl. vessel 927	292.336	0.00000	0.00000	8551.191
928	cyl. vessel 928	292.385	0.00000	0.00000	8551.579
930	vessel dome 930	292.404	0.00000	0.00000	19146.645
1011	Shroud bottom MLI	31.091	0.00000	0.00000	0.000
1012	Shroud bottom MLI	31.055	0.00000	0.00000	0.000
1013	Shroud bottom MLI	34.574	0.00000	0.00000	0.000
1014	Shroud bottom MLI	38.888	0.00000	0.00000	0.000
1015	Shroud bottom MLI	42.626	0.00000	0.00000	0.000
1016	Shroud bottom MLI	45.250	0.00000	0.00000	0.000
1017	Shroud bottom MLI	45.706	0.00000	0.00000	0.000
1018	Shroud bottom MLI	42.427	0.00000	0.00000	0.000
1021	Shroud cyl. MLI	31.091	0.00000	0.00000	0.000
1022	Shroud cyl. MLI	31.055	0.00000	0.00000	0.000
1023	Shroud cyl. MLI	34.574	0.00000	0.00000	0.000
1024	Shroud cyl. MLI	38.888	0.00000	0.00000	0.000
1025	Shroud cyl. MLI	42.626	0.00000	0.00000	0.000
1026	Shroud cyl. MLI	45.250	0.00000	0.00000	0.000
1027	Shroud cyl. MLI	45.706	0.00000	0.00000	0.000
1028	Shroud cyl. MLI	42.427	0.00000	0.00000	0.000
1030	Shroud top MLI	49.196	0.00000	0.00000	0.000
1121	CTA cyl. HS 1121	49.777	0.00000	0.00000	226.532
1122	CTA cyl. HS 1122	49.751	0.00000	0.00000	226.254
1123	CTA cyl. HS 1122	52.823	0.00000	0.00000	259.359
1124	CTA cyl. HS 1122	56.553	0.00000	0.00000	299.564
1125	CTA cyl. HS 1122	59.766	0.00000	0.00000	334.191
1126	CTA cyl. HS 1122	62.038	0.00000	0.00000	359.647
1127	CTA cyl. HS 1122	62.425	0.00000	0.00000	364.002
1128	CTA cyl. HS 1122	59.593	0.00000	0.00000	332.327
1130	CTA top HS 1130	65.197	0.00000	0.00000	587.192
1201	CTA Shroud lo Baf	6.202	0.00000	0.00000	0.179
1211	CTA Shroud up Baf	4.882	0.00000	0.00000	0.101
1221	CTA cy.Shroud 1221	4.511	0.00000	0.00000	0.000
1222	CTA cy.Shroud 1222	4.479	0.00000	0.00000	0.000
1223	CTA cy.Shroud 1223	4.548	0.00000	0.00000	0.000
1224	CTA cy.Shroud 1224	4.559	0.00000	0.00000	0.000
1225	CTA cy.Shroud 1225	4.645	0.00000	0.00000	0.000
1226	CTA cy.Shroud 1226	4.646	0.00000	0.00000	0.000
1227	CTA cy.Shroud 1227	4.715	0.00000	0.00000	0.000
1228	CTA cy.Shroud 1228	4.655	0.00000	0.00000	0.000
1230	CTA topShroud 1230	5.142	0.00000	0.00000	0.696
1240	CTA Reflector	21.072	0.00000	0.00000	32.717
1250	Refl. I/F bracket 1	19.672	0.00000	0.00000	0.000
1252	Refl. I/F br.1 pos.2	168.852	0.00000	0.00000	0.000
1253	Refl. I/F br.1 pos.3	170.212	0.00000	0.00000	0.000

1254	Refl. I/F br.1 pos.4	137.880	0.00000	0.00000	0.000
1255	Refl. I/F br.1 pos.5	140.087	0.00000	0.00000	0.000
1256	Refl. I/F br.1 pos.6	222.619	0.00000	0.00000	0.000
1257	Refl. I/F br.1 pos.7	224.341	0.00000	0.00000	0.000
1260	Refl. I/F bracket 2	22.109	0.00000	0.00000	0.000
1262	Refl. I/F br.2 pos.2	169.578	0.00000	0.00000	0.000
1263	Refl. I/F br.2 pos.3	170.935	0.00000	0.00000	0.000
1264	Refl. I/F br.2 pos.4	138.433	0.00000	0.00000	0.000
1265	Refl. I/F br.2 pos.5	140.630	0.00000	0.00000	0.000
1266	Refl. I/F br.2 pos.6	222.816	0.00000	0.00000	0.000
1267	Refl. I/F br.2 pos.7	224.532	0.00000	0.00000	0.000
1270	Refl. I/F bracket 3	24.618	0.00000	0.00000	0.000
1272	Refl. I/F br.3 pos.2	169.838	0.00000	0.00000	0.000
1273	Refl. I/F br.3 pos.3	171.186	0.00000	0.00000	0.000
1274	Refl. I/F br.3 pos.4	139.175	0.00000	0.00000	0.000
1275	Refl. I/F br.3 pos.5	141.358	0.00000	0.00000	0.000
1276	Refl. I/F br.3 pos.6	223.129	0.00000	0.00000	0.000
1277	Refl. I/F br.3 pos.7	224.837	0.00000	0.00000	0.000
1311	CTA HS bottom MLI	268.518	0.00000	0.00000	0.000
1312	CTA HS bottom MLI	268.503	0.00000	0.00000	0.000
1313	CTA HS bottom MLI	268.499	0.00000	0.00000	0.000
1314	CTA HS bottom MLI	268.494	0.00000	0.00000	0.000
1315	CTA HS bottom MLI	268.497	0.00000	0.00000	0.000
1316	CTA HS bottom MLI	268.518	0.00000	0.00000	0.000
1317	CTA HS bottom MLI	268.559	0.00000	0.00000	0.000
1318	CTA HS bottom MLI	268.565	0.00000	0.00000	0.000
1321	CTA HS cyl. MLI	268.789	0.00000	0.00000	0.000
1322	CTA HS cyl. MLI	268.772	0.00000	0.00000	0.000
1323	CTA HS cyl. MLI	268.741	0.00000	0.00000	0.000
1324	CTA HS cyl. MLI	268.580	0.00000	0.00000	0.000
1325	CTA HS cyl. MLI	268.566	0.00000	0.00000	0.000
1326	CTA HS cyl. MLI	268.612	0.00000	0.00000	0.000
1327	CTA HS cyl. MLI	268.795	0.00000	0.00000	0.000
1328	CTA HS cyl. MLI	268.823	0.00000	0.00000	0.000
1330	CTA HS top MLI	272.875	0.00000	0.00000	0.000
2000	CTA-Shroud Dewar	4.200	0.00000	0.00000	0.000
2001	GHe Shroud 1221 out	4.253	0.00000	0.00000	0.000
2002	GHe Shroud 1222 out	4.291	0.00000	0.00000	0.000
2003	GHe Shroud 1223 out	4.335	0.00000	0.00000	0.000
2004	GHe Shroud 1224 out	4.373	0.00000	0.00000	0.000
2005	GHe Shroud 1225 out	4.420	0.00000	0.00000	0.000
2006	GHe Shroud 1226 out	4.459	0.00000	0.00000	0.000
2007	GHe Shroud 1227 out	4.503	0.00000	0.00000	0.000
2008	GHe Shroud 1228 out	4.529	0.00000	0.00000	0.000
2011	GHe HS 1121 out	29.693	0.00000	0.00000	0.000
2012	GHe HS 1122 out	38.875	0.00000	0.00000	0.000
2013	GHe HS 1123 out	45.597	0.00000	0.00000	0.000
2014	GHe HS 1124 out	51.065	0.00000	0.00000	0.000
2015	GHe HS 1125 out	55.502	0.00000	0.00000	0.000
2016	GHe HS 1126 out	58.889	0.00000	0.00000	0.000
2017	GHe HS 1127 out	60.735	0.00000	0.00000	0.000
2018	GHe HS 1128 out	60.142	0.00000	0.00000	0.000
2021	GHe I/F bracket 1250 out	7.887	0.00000	0.00000	0.000
2022	GHe I/F bracket 1260 out	11.238	0.00000	0.00000	0.000
2023	GHe I/F bracket 1270 out	14.572	0.00000	0.00000	0.000
9999	AMBIENT	293.000	0.00000	0.00000	0.000

Heat Balance for PAYLOAD incl. Instrument Shield MLI

=====		
Level 0: from Aux. Tank into instruments	-15.975	[mW]
Level 2: from spatial framework into OB	0.069	[mW]
Level 1/2: from Aux. Tank into OB via ventline wall	-0.064	[mW]
Level 2: from HS1 into OB via ventline wall	0.157	[mW]
Level 2: via harness into OB	27.148	[mW]
via radiation from HS1 upper bulkhead onto Instrument MLI	0.234	[mW]
via radiation from Cryostat cavity onto OB lower side	5.132	[mW]
via radiation from HS1-baffle into payload	0.007	[mW]
via radiation from HS2-baffle into payload	0.023	[mW]
via radiation from HS3-baffle into payload	1.511	[mW]
via radiation from CTCE-4K-shrouds into payload	-0.015	[mW]
via radiation from CTCE lower-shroud baffle into payload	-0.002	[mW]
via radiation from CTCE upper-shroud baffle into payload	-0.002	[mW]
via radiation from CTCE reflector into payload	0.011	[mW]
via radiation from CVV-LOU-Window onto HIFI-Baffle	19.953	[mW]
via radiation from CVV-LOU-Window onto HIFI-FPU	14.512	[mW]
Vent line cooling power (out of payload)	102.030	[mW]
Transferred by convection from PL-ventline on helium	102.077	[mW]
total dissipation of PACS	5.070	[mW]
total dissipation of SPIRE	21.167	[mW]
total dissipation of HIFI	16.867	[mW]
Harness dissipation on OB	4.462	[mW]
Payload Heat Imbalance (shall be 0)	-1.762	[mW]

Heat Balance for Main Tank Ventline

=====		
conducted and radiated into ventline attached to HS1	3204.627	[mW]
conducted and radiated into ventline attached to HS2	5791.873	[mW]
conducted and radiated into ventline attached to HS3 +Z	19179.208	[mW]
conducted and radiated into ventline attached to HS3 -Z	19153.378	[mW]
conducted into ventline walls from CVV	56921.430	[mW]
conducted and radiated into line baf to HS 1	0.152	[mW]
Main Tank Ventline cooling power (out of ventline)	104250.767	[mW]
Via convection into ventline walls	-104260.686	[mW]
Main Tank Ventline Imbalance (shall be 0)	-0.100	[mW]

Heat Balance for CTCE

=====		
Convective heat transfer onto CTCE-external insulation	27236.651	[mW]
Conducted from CVV into CTCE-structure	-276.405	[mW]
Radiated from Payload into CTCE-shrouds incl. baffles	0.018	[mW]
Radiated from HS-baffles onto CTCE-shroud	48.897	[mW]
Radiated from CVV flange disc within cavity onto CTCE-MLI	2061.679	[mW]
Radiated from Payload onto reflector	-0.011	[mW]
Conducted from CTCE-structure into CTCE-shrouds	0.000	[mW]
Cooling power of CTCE-shrouds	29070.834	[mW]
CTCE Imbalance (shall be 0)	-0.005	[mW]

Heat Balance for Reflector within CTCE

=====		
via struts from CTCE-I/F brackets into reflector	0.120	[mW]
by radiation from CTCE-shrouds into reflector	-0.114	[mW]
by radiation from Payload into reflector	-0.011	[mW]
reflector heater power	0.000	[mW]
reflector total imbalance (shall be 0)	-0.004	[mW]

Heat Balance for whole Cryostat including Payload, Ventlines and CTCE

=====		
Convective heat transfer onto external walls	133260.946	[mW]
total heat transferred on gaseous helium	133423.632	[mW]
evaporation power in main and aux. tank	2086.521	[mW]
Total instrument power dissipation	43.104	[mW]
total main & auxiliary tank and reflector heater power	2014.000	[mW]
heater power of CVV lower bulkhead HTR	0.000	[mW]
total harness dissipation within system	19.601	[mW]
Cooling power of CTCE-shrouds	29070.834	[mW]
Cryostat total imbalance (shall be 0)	-172.501	[mW]

Heat Balance for Main Tank

=====

Main tank dissipation + heater power	2000.000 [mW]
heat from Aux. tank via mech. I/F	-0.451 [mW]
radiated from aux. tank	0.000 [mW]
conducted from spatial framework	30.638 [mW]
transferred through MLI	9.750 [mW]
conducted from rest	0.290 [mW]
radiated from spatial framework and HSs	0.077 [mW]
conducted from main tank ventline wall	0.000 [mW]
radiated from payload	0.000 [mW]
total heat into main tank	2040.303 [mW]

Heat Balance for Auxiliary Tank

=====

Aux. tank dissipation + heater power	14.000 [mW]
heat from Main tank via mech. I/F	0.451 [mW]
radiated from Main tank	0.000 [mW]
radiated from spatial framework and HSs	0.015 [mW]
conducted from payload L0	15.975 [mW]
conducted from payload L2	0.064 [mW]
radiated from payload	0.012 [mW]
conducted from filling tube	0.007 [mW]
radiated from MLI filling tube	15.692 [mW]
total heat into Aux. tank	46.217 [mW]

Heat flows into Tanks

=====

Into Main Tank	2040.303 [mW]
Into Aux. Tank	46.217 [mW]

Helium evaporation mass flow rates

=====

Out of Main Tank	97.529 [mg/s]
Out of Aux. Tank	2.028 [mg/s]
Out of external He- dewar for CTA-shroud cooling	100.000 [mg/s]

5.3 CTCE-Design-1 Case 3

CTCE-design1 means: MLI-design concept for CTCE as defined in § 4.5.2.1

Case 3 means: EQM-aux. Tank heater power = 14 mW

Reflector heater power = 40 mW

The input parameters are compiled in Table 5-9 and a brief temperature results summary is given in Table 5-11. The complete ESATAN-output-file listing is appended. The respective node numbers and labels are referenced in the thermal design and thermal-mathematical model descriptions in § 4

Input parameter	
Main Tank temperature	4.2 K
EQM-aux. Tank temperature	1.7 K
External Hel dewar temp. for CTCE-shroud cooling	4.2 K
Main Tank heater power	2000 mW
EQM-auxiliary tank heater power	14 mW
CTCE-shroud He-mass flow rate	100 mg/s
Reflector heater power	40 mW

Table 5-9: Input parameters

Submodel	Node #	Node Label	T (K)	T _{max} (K) Required	Requirement fulfilled
CRYO	12, 22, 32	Heatshield 1	10 – 16	NA	NA
CRYO	13, 23, 33	Heatshield 2	22 – 38	NA	NA
CRYO	14, 15, 24, 25, 34, 35	Heatshield 3	98 – 143	NA	NA
CRYO	4001 - 4078	CVV	293	NA	NA
CRYO	4090	LOU window	290	NA	NA
CRYO:PLM	371 - 381	Optical Bench	11 – 12	15	yes

Submodel	Node #	Node Label	T (K)	T _{max} (K) Required	Requirement fulfilled
CRYO:PLM	811	SPIRE SM Detector enclosure	1.78	1.8	yes
CRYO:PLM	819	SPIRE Cooler Pump HS	1.77	1.8	yes
CRYO:PLM	820	SPIRE Cooler Evaporator HS	1.73	1.8	yes
CRYO:PLM	765	PACS Blue Detector	1.72	3.5	yes
CRYO:PLM	760	PACS Red Detector	1.70	1.75	yes
CRYO:PLM	781	PACS He-Pump	1.78	2.20	yes
CRYO:PLM	912	HIFI I0-Boundary	1.85	2.00	yes
CRYO:PLM	803	SPIRE Optical Bench	5.2	4.5	No 1)
CRYO:PLM	730	PACS Photometer Optics	3.2	5	yes
CRYO:PLM	725	PACS Collimator	3.2	5	yes
CRYO:PLM	720	PACS Spectrom. Housing	3.2	5	yes
CRYO:PLM	913	HIFI L1-interface	6.0	6	yes
CRYO:PLM	801	SPIRE PM JFET enclosure	11	13	yes
CRYO:PLM	802	SPIRE SM JFET enclosure	11	13	yes
CRYO:PLM	910	HIFI FPU Structure	11	13	yes
CTCE	901 -930	CTCE vessel	292	NA	NA
CTCE	1221 - 1230	CTA-shroud	4.6 – 5.3	5	yes
CTCE	1121 – 1130	CTA- heatshield	68 – 88	NA	NA
CTCE	1240	CTA-Reflector	82	40 -80	yes
CTCE	1250, 1260, 1270	Reflector interface brackets (or optical bench)	20 – 25	NA	NA
		Mass-flow rate (mg/s)	required mass-flow rate (mg/s)	Requirement fulfilled	
Out of main tank		98	NA**)	NA	
Out of EQM-auxiliary tank		2.0	2.1	yes	
Out of external He-dewar for CTA-shroud cooling		100	NA **)	NA	

1) requirement not yet approved by ASED

**) to be verified whether pressure drop is not too high

Table 5-11: Brief results summary

EUROPEAN SPACE AGENCY THERMAL ANALYSIS NETWORK (VERSION 8.5.0)
 PAGE 1 20 FEBRUARY 2002 13:23:37

EQM4

```
#####
#
# Main Tank heater power:      2000 mW
# Aux. Tank heater power:      14 mW
# CTCE-shroud mass flow rate:  100 mg/s
# Reflector HTR power:         40 mW
#
#####
```

+EQM4:CRYO

NODE		LABEL	T	QI	QR	C
1	MAIN TANK		4.200	0.00000	2.00000	0.000
2	AUX TANK		1.700	0.00000	0.01400	0.000
5	Ti-head	lo 5	11.290	0.00000	0.00000	71.108
6	belt fitting	lo 6	10.681	0.00000	0.00000	63.278
7	strut tank end	lo 7	4.359	0.00000	0.00000	21.852
8	Ti-head	up 8	11.402	0.00000	0.00000	72.057
9	belt fitting	up 9	10.793	0.00000	0.00000	64.202
10	strut tank end	up 10	4.364	0.00000	0.00000	21.877
12	HS 1 BULK	12	10.597	0.00000	0.00000	14.052
13	HS 2 BULK	13	22.980	0.00000	0.00000	140.121
14	HS 3 BULK +Z	14	119.571	0.00000	0.00000	2768.274
15	HS 3 BULK -Z	15	119.538	0.00000	0.00000	2767.632
22	HS 1 CYL	22	10.522	0.00000	0.00000	44.736
23	HS 2 CYL	23	21.966	0.00000	0.00000	330.577
24	HS 3 CYL +Z	24	97.622	0.00000	0.00000	6860.336
25	HS 3 CYL -Z	25	97.520	0.00000	0.00000	6851.034
32	HS 1 CONE	32	15.544	0.00000	0.00000	91.924
33	HS 2 CONE	33	38.005	0.00000	0.00000	1510.711
34	HS 3 CONE +Z	34	142.339	0.00000	0.00000	7728.782
35	HS 3 CONE -Z	35	142.545	0.00000	0.00000	7728.782
42	HS 1 HIFI Baf. int.		25.657	0.00000	0.00000	2.933
52	HS 1 HIFI Baf. ext.		32.989	0.00000	0.00000	2.678
53	HS 2 HIFI Baf.		57.601	0.00000	0.00000	10.631
54	HS 3 HIFI Baf.		175.281	0.00000	0.00000	45.570
62	HS 1 Tele BAF		15.572	0.00000	0.00000	0.347
63	HS 2 Tele BAF		38.192	0.00000	0.00000	5.546
64	HS 3 Tele BAF		142.244	0.00000	0.00000	81.108
101	MLI MAIN TANK LO	101	5.168	0.00000	0.00000	15.688
105	MLI MAIN TANK CY	105	4.735	0.00000	0.00000	43.338
106	MLI MAIN TANK UP	106	37.070	0.00000	0.00000	112.535
112	MLI HS 1 BULK	112	20.325	0.00000	0.00000	39.951
113	MLI HS 2 BULK	113	115.125	0.00000	0.00000	382.024
114	MLI HS 3 BULK +Z	114	287.452	0.00000	0.00000	706.439
115	MLI HS 3 BULK -Z	115	287.428	0.00000	0.00000	706.381
122	MLI HS 1 CYL	122	19.258	0.00000	0.00000	123.022
123	MLI HS 2 CYL	123	93.752	0.00000	0.00000	969.392
124	MLI HS 3 CYL +Z	124	286.653	0.00000	0.00000	2100.823
125	MLI HS 3 CYL -Z	125	285.595	0.00000	0.00000	2093.071
132	MLI HS 1 CONE	132	51.503	0.00000	0.00000	249.833
133	MLI HS 2 CONE	133	137.825	0.00000	0.00000	1125.837
134	MLI HS 3 CONE +Z	134	287.294	0.00000	0.00000	1702.066
135	MLI HS 3 CONE -Z	135	287.274	0.00000	0.00000	1701.947
440	filling tube	440	271.528	0.00000	0.00000	0.000

441	filling tube	441	252.225	0.00000	0.00000	0.000
442	filling tube	442	245.520	0.00000	0.00000	0.000
443	filling tube	443	242.460	0.00000	0.00000	0.000
447	empty tube	447	15.532	0.00000	0.00000	0.000
452	empty tube	452	10.866	0.00000	0.00000	0.000
502	line baf to HS1	502	4.201	0.00000	0.00000	0.000
642	MLI filling tube	642	120.439	0.00000	0.00000	0.766
643	MLI filling tube	643	119.021	0.00000	0.00000	0.743
647	MLI filling tube	647	25.817	0.00000	0.00000	1.245
652	MLI filling tube	652	23.551	0.00000	0.00000	0.459
1000	HS 1 SUSP BOLT	1000	19.629	0.00000	0.00000	0.000
2000	HS 2 SUSP BOLT	2000	67.891	0.00000	0.00000	0.000
3000	HS 3 SUSP BOLT	3000	189.811	0.00000	0.00000	0.000
4001	CVV lower bulk	4001	292.764	0.00000	0.00000	4399.464
4002	CVV lower bulk	4002	292.771	0.00000	0.00000	4399.491
4003	CVV lower bulk	4003	292.771	0.00000	0.00000	4399.491
4004	CVV lower bulk	4004	292.764	0.00000	0.00000	4399.462
4005	CVV lower bulk	4005	292.750	0.00000	0.00000	4399.407
4006	CVV lower bulk	4006	292.749	0.00000	0.00000	4399.404
4007	CVV lower bulk	4007	292.759	0.00000	0.00000	4399.442
4008	CVV lower bulk	4008	292.760	0.00000	0.00000	4399.449
4011	CVV lower bulk	4011	292.707	0.00000	0.00000	1668.975
4012	CVV lower bulk	4012	292.740	0.00000	0.00000	1669.026
4013	CVV lower bulk	4013	292.741	0.00000	0.00000	1669.028
4014	CVV lower bulk	4014	292.717	0.00000	0.00000	1668.991
4015	CVV lower bulk	4015	292.654	0.00000	0.00000	1668.893
4016	CVV lower bulk	4016	292.654	0.00000	0.00000	1668.894
4017	CVV lower bulk	4017	292.705	0.00000	0.00000	1668.971
4018	CVV lower bulk	4018	292.700	0.00000	0.00000	1668.964
4031	CVV cyl lower	4031	292.553	0.00000	0.00000	13706.679
4032	CVV cyl lower	4032	292.661	0.00000	0.00000	13708.039
4033	CVV cyl lower	4033	292.663	0.00000	0.00000	13708.074
4034	CVV cyl lower	4034	292.599	0.00000	0.00000	13707.263
4035	CVV cyl lower	4035	292.392	0.00000	0.00000	13704.652
4036	CVV cyl lower	4036	292.397	0.00000	0.00000	13704.711
4037	CVV cyl lower	4037	292.569	0.00000	0.00000	13706.877
4038	CVV cyl lower	4038	292.537	0.00000	0.00000	13706.479
4041	CVV cyl upper	4041	292.694	0.00000	0.00000	19514.609
4042	CVV cyl upper	4042	292.699	0.00000	0.00000	19514.697
4043	CVV cyl upper	4043	292.633	0.00000	0.00000	19513.515
4044	CVV cyl upper	4044	292.216	0.00000	0.00000	19506.022
4045	CVV cyl upper	4045	289.662	0.00000	0.00000	19460.121
4046	CVV cyl upper	4046	289.657	0.00000	0.00000	19460.026
4047	CVV cyl upper	4047	292.187	0.00000	0.00000	19505.492
4048	CVV cyl upper	4048	292.604	0.00000	0.00000	19512.980
4051	CVV upper bulk	4051	292.714	0.00000	0.00000	19050.968
4052	CVV upper bulk	4052	292.627	0.00000	0.00000	19049.443
4053	CVV upper bulk	4053	292.618	0.00000	0.00000	19049.278
4054	CVV upper bulk	4054	292.670	0.00000	0.00000	19050.188
4055	CVV upper bulk	4055	292.589	0.00000	0.00000	19048.779
4056	CVV upper bulk	4056	292.545	0.00000	0.00000	19048.002
4057	CVV upper bulk	4057	292.681	0.00000	0.00000	19050.386
4058	CVV upper bulk	4058	292.719	0.00000	0.00000	19051.064
4061	CVV/CTA flange	4061	292.330	0.00000	0.00000	0.000
4062	CVV/CTA flange	4062	292.307	0.00000	0.00000	0.000
4063	CVV/CTA flange	4063	292.286	0.00000	0.00000	0.000
4064	CVV/CTA flange	4064	292.263	0.00000	0.00000	0.000
4065	CVV/CTA flange	4065	292.240	0.00000	0.00000	0.000
4066	CVV/CTA flange	4066	292.244	0.00000	0.00000	0.000
4067	CVV/CTA flange	4067	292.299	0.00000	0.00000	0.000
4068	CVV/CTA flange	4068	292.326	0.00000	0.00000	0.000
4071	CVV flange disc	4071	292.174	0.00000	0.00000	0.000
4072	CVV flange disc	4072	292.162	0.00000	0.00000	0.000

4073	CVV flange disc	4073	292.144	0.00000	0.00000	0.000
4074	CVV flange disc	4074	292.127	0.00000	0.00000	0.000
4075	CVV flange disc	4075	292.114	0.00000	0.00000	0.000
4076	CVV flange disc	4076	292.121	0.00000	0.00000	0.000
4077	CVV flange disc	4077	292.150	0.00000	0.00000	0.000
4078	CVV flange disc	4078	292.171	0.00000	0.00000	0.000
4090	CVV Lo window		289.929	0.00000	0.00000	15.604
4631	SUSP TI lo	4631	282.781	0.00000	0.00000	84.266
4632	SUSP TI lo	4632	282.880	0.00000	0.00000	84.277
4633	SUSP TI lo	4633	282.883	0.00000	0.00000	84.277
4634	SUSP TI lo	4634	282.823	0.00000	0.00000	84.271
4635	SUSP TI lo	4635	282.633	0.00000	0.00000	84.250
4636	SUSP TI lo	4636	282.637	0.00000	0.00000	84.251
4637	SUSP TI lo	4637	282.795	0.00000	0.00000	84.268
4638	SUSP TI lo	4638	282.766	0.00000	0.00000	84.265
4641	SUSP TI up	4641	282.911	0.00000	0.00000	84.280
4642	SUSP TI up	4642	282.915	0.00000	0.00000	84.281
4643	SUSP TI up	4643	282.855	0.00000	0.00000	84.274
4644	SUSP TI up	4644	282.471	0.00000	0.00000	84.233
4645	SUSP TI up	4645	280.122	0.00000	0.00000	83.983
4646	SUSP TI up	4646	280.117	0.00000	0.00000	83.982
4647	SUSP TI up	4647	282.444	0.00000	0.00000	84.230
4648	SUSP TI up	4648	282.828	0.00000	0.00000	84.271
4731	CABLE PLUG	4731	281.499	0.00073	0.00000	93.529
4732	CABLE PLUG	4732	291.588	0.00000	0.00000	97.058
4733	CABLE PLUG	4733	291.591	0.00000	0.00000	97.059
4734	CABLE PLUG	4734	291.527	0.00000	0.00000	97.036
4735	CABLE PLUG	4735	291.321	0.00000	0.00000	96.964
4736	CABLE PLUG	4736	292.397	0.00000	0.00000	97.341
4737	CABLE PLUG	4737	292.569	0.00000	0.00000	97.401
4738	CABLE PLUG	4738	283.622	0.00010	0.00000	94.272
6051	X2 SI Harness	51	245.203	0.00073	0.00000	0.000
6052	X2 SI Harness	52	205.934	0.00073	0.00000	0.000
6053	X2 SI Harness	53	162.825	0.00073	0.00000	0.000
6054	X2 SI Harness	54	113.892	0.00073	0.00000	0.000
6055	X2 SI at HS1	55	50.556	0.00250	0.00000	0.000
6056	X3 SI Harness	56	45.811	0.00250	0.00000	0.000
6057	X3 SI Harness	57	39.330	0.00250	0.00000	0.000
6058	X3 SI Harness	58	29.983	0.00250	0.00000	0.000
6061	X2 JF Harness	61	246.339	0.00010	0.00000	0.000
6062	X2 JF Harness	62	205.932	0.00010	0.00000	0.000
6063	X2 JF Harness	63	161.456	0.00010	0.00000	0.000
6064	X2 JF Harness	64	110.711	0.00010	0.00000	0.000
6065	X2 JF at HS1	65	42.549	0.00024	0.00000	0.000
6066	X3 JF Harness	66	38.147	0.00024	0.00000	0.000
6067	X3 JF Harness	67	33.067	0.00024	0.00000	0.000
6068	X3 JF Harness	68	26.908	0.00024	0.00000	0.000
9999	AMBIENT		293.000	0.00000	0.00000	0.000

+EQM4:CRYO:V

NODE		LABEL	T	QI	QR	C
201	OSS-TUBE	201	4.200	0.00000	0.00000	0.000
202	BAFFLE LO	202	4.200	0.00000	0.00000	0.000
203	BAFFLE UP	203	4.200	0.00000	0.00000	0.000
204	1ST HS	204	10.522	0.00000	0.00000	0.000
205	2ND HS	205	21.966	0.00000	0.00000	0.000
206	3RD HS +z	206	97.622	0.00000	0.00000	0.000
207	3RD HS -z	207	97.520	0.00000	0.00000	0.000
210	VENT VESSEL	210	209.882	0.00000	0.00000	0.000
212	BAFFLE - 1ST HS	212	4.201	0.00000	0.00000	0.000
251	TANK HE-OUT	251	4.200	0.00000	0.00000	0.000
252	OSS HE-OUT	252	4.200	0.00000	0.00000	0.000
253	BAFFLE LO HE-OUT	253	4.200	0.00000	0.00000	0.000
254	BAFFLE UP HE-OUT	254	4.200	0.00000	0.00000	0.000
255	1ST HS HE-OUT	255	10.522	0.00000	0.00000	0.000
256	2ND HS HE-OUT	256	21.947	0.00000	0.00000	0.000
257	3RD HS HE-OUT	257	97.571	0.00000	0.00000	0.000
260	VESSEL HE-OUT	260	209.882	0.00000	0.00000	0.000
262	BAF - HS1 HE-OUT	262	4.200	0.00000	0.00000	0.000
296	HEATER WALL	296	293.000	0.00000	0.00000	0.000
297	HEATER HE-OUT	297	209.882	0.00000	0.00000	0.000

=====

+EQM4:CRYO:PLM

NODE	LABEL	T	QI	QR	C
310	Instr. Shield Cyl.	11.648	0.00000	0.00000	8.314
311	Instr. Shield Top	11.672	0.00000	0.00000	10.789
315	Instr. Shield Baffle	11.702	0.00000	0.00000	0.699
320	Vline wall Tank-PACS	1.756	0.00000	0.00000	0.007
321	Vline wall PACS I/F 1	2.408	0.00000	0.00000	0.001
322	Vline wall PACS I/F 1	2.660	0.00000	0.00000	0.000
323	Vline wall PACS I/F 1	2.493	0.00000	0.00000	0.001
324	Vline wall PACSI/F1/2	2.320	0.00000	0.00000	0.003
325	Vline wall PACSI/F1/2	2.350	0.00000	0.00000	0.014
326	Vline wall PACS I/F 2	2.728	0.00000	0.00000	0.001
327	Vline wall PACS I/F 2	2.883	0.00000	0.00000	0.000
328	Vline wall PACS I/F 2	2.791	0.00000	0.00000	0.001
329	Vline wall PACSI/F2/3	2.700	0.00000	0.00000	0.006
330	Vline wall PACSI/F2/3	2.766	0.00000	0.00000	0.002
331	Vline wall PACS I/F 3	2.901	0.00000	0.00000	0.001
332	Vline wall PACS I/F 3	3.008	0.00000	0.00000	0.000
333	Vline wall PACS I/F 3	2.960	0.00000	0.00000	0.001
334	Vline wall PACS-SPIRE	2.918	0.00000	0.00000	0.006
335	Vline wall PACS-SPIRE	2.941	0.00000	0.00000	0.008
336	Vline wall PACS-SPIRE	3.106	0.00000	0.00000	0.008
337	Vline wall SPIRE	4.082	0.00000	0.00000	0.001
338	Vline wall SPIRE	4.650	0.00000	0.00000	0.001
339	Vline wall SPIRE	4.388	0.00000	0.00000	0.001
340	Vline wall SPIRE-HIFI	4.175	0.00000	0.00000	0.012
341	Vline wall SPIRE-HIFI	4.189	0.00000	0.00000	0.015
342	Vline wall SPIRE-HIFI	4.296	0.00000	0.00000	0.018
343	Vline wall HIFI	5.243	0.00000	0.00000	0.002
344	Vline wall HIFI	5.802	0.00000	0.00000	0.001
345	Vline wall HIFI	6.113	0.00000	0.00000	0.003
346	Vline Lev.2 OB	10.183	0.00000	0.00000	0.072
347	Vline Lev.2 OB	11.243	0.00000	0.00000	0.208
348	Vline Lev.2 OB	11.358	0.00000	0.00000	0.083
349	Vline Lev.2 OB	11.427	0.00000	0.00000	0.133
350	Vline Lev.2 OB	11.454	0.00000	0.00000	0.078
351	Vline Lev.2 OB	11.458	0.00000	0.00000	0.231
352	Vline Lev.2 OB	11.483	0.00000	0.00000	0.118
371	Opt. Bench +Z	11.375	0.00000	0.00000	7.915
372	Opt. Bench +Z -Y	11.306	0.00000	0.00000	7.191
373	Opt. Bench +Z mid	11.386	0.00000	0.00000	18.606
374	Opt. Bench +Z +Y	11.403	0.00000	0.00000	3.014
375	Opt. Bench -Y	11.452	0.00000	0.00000	13.756
376	Opt. Bench centre	11.435	0.00000	0.00000	33.136
377	Opt. Bench +Y	11.441	0.00000	0.00000	7.299
378	Opt. Bench -Z -Y	11.486	0.00000	0.00000	7.515
379	Opt. Bench -Z mid	11.462	0.00000	0.00000	18.952
380	Opt. Bench -Z +Y	11.464	0.00000	0.00000	3.059
381	Opt. Bench -Z	11.459	0.00000	0.00000	8.079
390	I.Shld HIFI Baf. ext.	11.722	0.00000	0.00000	0.326
391	I.Shld HIFI Baf. int.	11.653	0.00000	0.00000	0.114
411	MLI on OB-Shield side	13.932	0.00000	0.00000	31.699
412	MLI on OB-Shield top	13.941	0.00000	0.00000	40.946
710	PACS-Top Optic	3.187	0.00000	0.00000	1.912
720	PACS-Spectrometer	3.185	0.00003	0.00000	2.162
725	PACS-Collimator	3.182	0.00000	0.00000	2.186
730	PACS-Photometer Optic	3.181	0.00000	0.00000	1.320
735	PACS-Internal	3.186	0.00000	0.00000	1.834
740	PACS-Lump	3.186	0.00000	0.00000	0.000
750	PACS-Chopper	3.190	0.00040	0.00000	0.115

755	PACS-Grating Assy	3.189	0.00100	0.00000	0.787
760	PACS-Red Detector	1.704	0.00000	0.00000	0.230
761	PACS-Red Detect. CRE	3.196	0.00030	0.00000	0.029
765	PACS-Blue Detector	1.724	0.00013	0.00000	0.233
766	PACS-Blue Detect. CRE	3.196	0.00030	0.00000	0.029
770	PACS-Filter Wh. Blue	3.185	0.00004	0.00000	0.134
771	PACS-Filter Wh. Photo	3.181	0.00004	0.00000	0.134
775	PACS-Calib. Source 1	3.188	0.00032	0.00000	0.019
776	PACS-Calib. Source 2	3.191	0.00032	0.00000	0.019
780	PACS-Photometer Housi	3.183	0.00000	0.00000	1.013
781	PACS-Photometer CooPu	1.781	0.00220	0.00000	0.147
791	PACS-STST-Strut 1,1	9.261	0.00000	0.00000	0.329
792	PACS-STST-Strut 4,1	9.257	0.00000	0.00000	0.512
793	PACS-STST-Strut 5,1	9.261	0.00000	0.00000	0.256
794	PACS-Kevlar-Strut Red 1	2.634	0.00000	0.00000	0.014
795	PACS-Kevlar-Strut Blue 1	2.638	0.00000	0.00000	0.014
796	PACS-HarnessRed Det.Intl	2.567	0.00000	0.00000	0.000
797	PACS-HarnessBlueDet.Intl	2.573	0.00000	0.00000	0.000
798	PACS-HarnessBlue1.7->4,1	2.558	0.00000	0.00000	0.000
801	SPIRE PM JFET ENCL	11.492	0.01026	0.00000	11.467
802	SPIRE SM JFET ENCL	11.467	0.00282	0.00000	3.720
803	SPIRE Optical Bench	5.278	0.00000	0.00000	10.670
804	SPIRE RF Filter Box	5.283	0.00428	0.00000	0.522
805	SPIRE Beam St. Mech	5.279	0.00100	0.00000	0.391
806	SPIRE SMECm	5.279	0.00048	0.00000	0.462
807	SPIRE PM calibrator	5.279	0.00002	0.00000	0.000
808	SPIRE SM calibrator	9.545	0.00040	0.00000	0.000
809	SPIRE Shutter	5.278	0.00000	0.00000	0.000
810	SPIRE PM Detector en	1.802	0.00000	0.00000	0.453
811	SPIRE SM Detector en	1.778	0.00000	0.00000	0.270
812	SPIRE PM Detectors	1.743	0.00000	0.00000	0.398
813	SPIRE SM detector	1.743	0.00000	0.00000	0.252
816	SPIRE Cooler Pump	1.888	0.00183	0.00000	0.000
817	SPIRE Cooler shunt	1.726	0.00000	0.00000	0.000
818	SPIRE Cooler evap	1.743	0.00000	0.00000	0.000
819	SPIRE Cooler pump HS	1.774	0.00008	0.00000	0.000
820	SPIRE Cooler evap HS	1.726	0.00000	0.00000	0.000
900	HIFI 2K level	1.861	0.00014	0.00000	0.030
905	HIFI Harness 1 int.point	6.063	0.00036	0.00000	0.000
910	HIFI FPU Structure	11.465	0.01602	0.00000	108.103
912	HIFI L0 boundary node	1.854	0.00000	0.00000	0.000
913	HIFI L1 boundary node	6.059	0.00000	0.00000	0.000
914	HIFI Harness 2a int.poin	12.721	0.00036	0.00000	0.000
915	HIFI Harness 2b int.poin	9.163	0.00000	0.00000	0.000
920	HIFI Internal Assy.	6.064	0.00000	0.00000	0.025
5000	GHe tank outlet	1.700	0.00000	0.00000	0.000
5010	GHe PACS I/F 1 in	1.753	0.00000	0.00000	0.000
5011	GHe PACS I/F 1	1.971	0.00000	0.00000	0.000
5012	GHe PACS I/F 1	2.111	0.00000	0.00000	0.000
5013	GHe PACS I/F 1 out	2.246	0.00000	0.00000	0.000
5014	GHe PACS I/F 1/2	2.301	0.00000	0.00000	0.000
5020	GHe PACS I/F 2 in	2.348	0.00000	0.00000	0.000
5021	GHe PACS I/F 2	2.490	0.00000	0.00000	0.000
5022	GHe PACS I/F 2	2.578	0.00000	0.00000	0.000
5023	GHe PACS I/F 2 out	2.661	0.00000	0.00000	0.000
5024	GHe PACS I/F 2/3	2.697	0.00000	0.00000	0.000
5030	GHe PACS I/F 3 in	2.744	0.00000	0.00000	0.000
5031	GHe PACS I/F 3	2.806	0.00000	0.00000	0.000
5032	GHe PACS I/F 3	2.854	0.00000	0.00000	0.000
5033	GHe PACS I/F 3 out	2.897	0.00000	0.00000	0.000
5034	GHe PACS-SPIRE	2.916	0.00000	0.00000	0.000
5035	GHe PACS-SPIRE	2.939	0.00000	0.00000	0.000
5040	GHe SPIRE I/F in	3.098	0.00000	0.00000	0.000

5041	GHe SPIRE I/F	3.559	0.00000	0.00000	0.000
5042	GHe SPIRE I/F	3.876	0.00000	0.00000	0.000
5043	GHe SPIRE I/F out	4.129	0.00000	0.00000	0.000
5044	GHe SPIRE-HIFI	4.173	0.00000	0.00000	0.000
5045	GHe SPIRE-HIFI	4.188	0.00000	0.00000	0.000
5050	GHe HIFI I/F in	4.291	0.00000	0.00000	0.000
5051	GHe HIFI I/F	4.796	0.00000	0.00000	0.000
5052	GHe HIFI I/F	5.128	0.00000	0.00000	0.000
5053	GHe HIFI I/F out	5.694	0.00000	0.00000	0.000
5054	GHe Lev.2 OB	9.960	0.00000	0.00000	0.000
5055	GHe Lev.2 OB	11.179	0.00000	0.00000	0.000
5056	GHe Lev.2 OB	11.350	0.00000	0.00000	0.000
5057	GHe Lev.2 OB	11.423	0.00000	0.00000	0.000
5058	GHe Lev.2 OB	11.452	0.00000	0.00000	0.000
5059	GHe Lev.2 OB	11.458	0.00000	0.00000	0.000
5060	GHe Lev.2 OB	11.481	0.00000	0.00000	0.000
6059	X3 SI Harness 59	12.317	0.00406	0.00000	0.000
6069	X3 JF Harness 69	18.684	0.00040	0.00000	0.000
9999	Ambient Air	293.000	0.00000	0.00000	0.000

+EQM4:CTCE

NODE	LABEL	T	QI	QR	C
901	vessel flange 901	292.340	0.00000	0.00000	905.667
902	vessel flange 902	292.321	0.00000	0.00000	905.651
903	vessel flange 903	292.297	0.00000	0.00000	905.632
904	vessel flange 904	292.260	0.00000	0.00000	905.601
905	vessel flange 905	292.239	0.00000	0.00000	905.583
906	vessel flange 906	292.248	0.00000	0.00000	905.591
907	vessel flange 907	292.306	0.00000	0.00000	905.639
908	vessel flange 908	292.335	0.00000	0.00000	905.663
921	cyl. vessel 921	292.402	0.00000	0.00000	8551.714
922	cyl. vessel 922	292.384	0.00000	0.00000	8551.566
923	cyl. vessel 923	292.335	0.00000	0.00000	8551.181
924	cyl. vessel 924	292.140	0.00000	0.00000	8549.651
925	cyl. vessel 925	292.106	0.00000	0.00000	8549.380
926	cyl. vessel 926	292.141	0.00000	0.00000	8549.657
927	cyl. vessel 927	292.336	0.00000	0.00000	8551.192
928	cyl. vessel 928	292.385	0.00000	0.00000	8551.579
930	vessel dome 930	292.404	0.00000	0.00000	19146.645
1011	Shroud bottom MLI	31.179	0.00000	0.00000	0.000
1012	Shroud bottom MLI	31.147	0.00000	0.00000	0.000
1013	Shroud bottom MLI	34.670	0.00000	0.00000	0.000
1014	Shroud bottom MLI	38.985	0.00000	0.00000	0.000
1015	Shroud bottom MLI	42.721	0.00000	0.00000	0.000
1016	Shroud bottom MLI	45.343	0.00000	0.00000	0.000
1017	Shroud bottom MLI	45.798	0.00000	0.00000	0.000
1018	Shroud bottom MLI	42.518	0.00000	0.00000	0.000
1021	Shroud cyl. MLI	31.179	0.00000	0.00000	0.000
1022	Shroud cyl. MLI	31.147	0.00000	0.00000	0.000
1023	Shroud cyl. MLI	34.670	0.00000	0.00000	0.000
1024	Shroud cyl. MLI	38.985	0.00000	0.00000	0.000
1025	Shroud cyl. MLI	42.721	0.00000	0.00000	0.000
1026	Shroud cyl. MLI	45.343	0.00000	0.00000	0.000
1027	Shroud cyl. MLI	45.798	0.00000	0.00000	0.000
1028	Shroud cyl. MLI	42.518	0.00000	0.00000	0.000
1030	Shroud top MLI	49.297	0.00000	0.00000	0.000
1121	CTA cyl. HS 1121	49.845	0.00000	0.00000	227.268
1122	CTA cyl. HS 1122	49.823	0.00000	0.00000	227.026
1123	CTA cyl. HS 1122	52.896	0.00000	0.00000	260.153
1124	CTA cyl. HS 1122	56.627	0.00000	0.00000	300.365
1125	CTA cyl. HS 1122	59.839	0.00000	0.00000	334.982
1126	CTA cyl. HS 1122	62.110	0.00000	0.00000	360.456
1127	CTA cyl. HS 1122	62.495	0.00000	0.00000	364.788
1128	CTA cyl. HS 1122	59.660	0.00000	0.00000	333.057
1130	CTA top HS 1130	65.262	0.00000	0.00000	588.274
1201	CTA Shroud lo Baf	6.256	0.00000	0.00000	0.181
1211	CTA Shroud up Baf	4.943	0.00000	0.00000	0.102
1221	CTA cy.Shroud 1221	4.560	0.00000	0.00000	0.000
1222	CTA cy.Shroud 1222	4.530	0.00000	0.00000	0.000
1223	CTA cy.Shroud 1223	4.602	0.00000	0.00000	0.000
1224	CTA cy.Shroud 1224	4.619	0.00000	0.00000	0.000
1225	CTA cy.Shroud 1225	4.709	0.00000	0.00000	0.000
1226	CTA cy.Shroud 1226	4.714	0.00000	0.00000	0.000
1227	CTA cy.Shroud 1227	4.786	0.00000	0.00000	0.000
1228	CTA cy.Shroud 1228	4.726	0.00000	0.00000	0.000
1230	CTA topShroud 1230	5.329	0.00000	0.00000	0.776
1240	CTA Reflector	82.140	0.00000	0.04000	1074.921
1250	Refl. I/F bracket 1	19.734	0.00000	0.00000	0.000
1252	Refl. I/F br.1 pos.2	168.862	0.00000	0.00000	0.000
1253	Refl. I/F br.1 pos.3	170.222	0.00000	0.00000	0.000

1254	Refl. I/F br.1 pos.4	137.893	0.00000	0.00000	0.000
1255	Refl. I/F br.1 pos.5	140.100	0.00000	0.00000	0.000
1256	Refl. I/F br.1 pos.6	222.624	0.00000	0.00000	0.000
1257	Refl. I/F br.1 pos.7	224.346	0.00000	0.00000	0.000
1260	Refl. I/F bracket 2	22.178	0.00000	0.00000	0.000
1262	Refl. I/F br.2 pos.2	169.594	0.00000	0.00000	0.000
1263	Refl. I/F br.2 pos.3	170.951	0.00000	0.00000	0.000
1264	Refl. I/F br.2 pos.4	138.451	0.00000	0.00000	0.000
1265	Refl. I/F br.2 pos.5	140.647	0.00000	0.00000	0.000
1266	Refl. I/F br.2 pos.6	222.823	0.00000	0.00000	0.000
1267	Refl. I/F br.2 pos.7	224.539	0.00000	0.00000	0.000
1270	Refl. I/F bracket 3	24.692	0.00000	0.00000	0.000
1272	Refl. I/F br.3 pos.2	169.856	0.00000	0.00000	0.000
1273	Refl. I/F br.3 pos.3	171.204	0.00000	0.00000	0.000
1274	Refl. I/F br.3 pos.4	139.198	0.00000	0.00000	0.000
1275	Refl. I/F br.3 pos.5	141.382	0.00000	0.00000	0.000
1276	Refl. I/F br.3 pos.6	223.138	0.00000	0.00000	0.000
1277	Refl. I/F br.3 pos.7	224.846	0.00000	0.00000	0.000
1311	CTA HS bottom MLI	268.518	0.00000	0.00000	0.000
1312	CTA HS bottom MLI	268.504	0.00000	0.00000	0.000
1313	CTA HS bottom MLI	268.500	0.00000	0.00000	0.000
1314	CTA HS bottom MLI	268.494	0.00000	0.00000	0.000
1315	CTA HS bottom MLI	268.497	0.00000	0.00000	0.000
1316	CTA HS bottom MLI	268.518	0.00000	0.00000	0.000
1317	CTA HS bottom MLI	268.560	0.00000	0.00000	0.000
1318	CTA HS bottom MLI	268.565	0.00000	0.00000	0.000
1321	CTA HS cyl. MLI	268.789	0.00000	0.00000	0.000
1322	CTA HS cyl. MLI	268.772	0.00000	0.00000	0.000
1323	CTA HS cyl. MLI	268.741	0.00000	0.00000	0.000
1324	CTA HS cyl. MLI	268.581	0.00000	0.00000	0.000
1325	CTA HS cyl. MLI	268.567	0.00000	0.00000	0.000
1326	CTA HS cyl. MLI	268.613	0.00000	0.00000	0.000
1327	CTA HS cyl. MLI	268.795	0.00000	0.00000	0.000
1328	CTA HS cyl. MLI	268.824	0.00000	0.00000	0.000
1330	CTA HS top MLI	272.875	0.00000	0.00000	0.000
2000	CTA-Shroud Dewar	4.200	0.00000	0.00000	0.000
2001	GHe Shroud 1221 out	4.261	0.00000	0.00000	0.000
2002	GHe Shroud 1222 out	4.307	0.00000	0.00000	0.000
2003	GHe Shroud 1223 out	4.357	0.00000	0.00000	0.000
2004	GHe Shroud 1224 out	4.402	0.00000	0.00000	0.000
2005	GHe Shroud 1225 out	4.455	0.00000	0.00000	0.000
2006	GHe Shroud 1226 out	4.500	0.00000	0.00000	0.000
2007	GHe Shroud 1227 out	4.550	0.00000	0.00000	0.000
2008	GHe Shroud 1228 out	4.581	0.00000	0.00000	0.000
2011	GHe HS 1121 out	29.775	0.00000	0.00000	0.000
2012	GHe HS 1122 out	38.960	0.00000	0.00000	0.000
2013	GHe HS 1123 out	45.681	0.00000	0.00000	0.000
2014	GHe HS 1124 out	51.146	0.00000	0.00000	0.000
2015	GHe HS 1125 out	55.582	0.00000	0.00000	0.000
2016	GHe HS 1126 out	58.966	0.00000	0.00000	0.000
2017	GHe HS 1127 out	60.809	0.00000	0.00000	0.000
2018	GHe HS 1128 out	60.212	0.00000	0.00000	0.000
2021	GHe I/F bracket 1250 out	7.945	0.00000	0.00000	0.000
2022	GHe I/F bracket 1260 out	11.303	0.00000	0.00000	0.000
2023	GHe I/F bracket 1270 out	14.644	0.00000	0.00000	0.000
9999	AMBIENT	293.000	0.00000	0.00000	0.000

Heat Balance for PAYLOAD incl. Instrument Shield MLI

=====		
Level 0: from Aux. Tank into instruments	-16.236	[mW]
Level 2: from spatial framework into OB	-0.397	[mW]
Level 1/2: from Aux. Tank into OB via ventline wall	-0.065	[mW]
Level 2: from HS1 into OB via ventline wall	0.154	[mW]
Level 2: via harness into OB	27.116	[mW]
via radiation from HS1 upper bulkhead onto Instrument MLI	0.229	[mW]
via radiation from Cryostat cavity onto OB lower side	5.129	[mW]
via radiation from HS1-baffle into payload	0.007	[mW]
via radiation from HS2-baffle into payload	0.023	[mW]
via radiation from HS3-baffle into payload	1.511	[mW]
via radiation from CTCE-4K-shrouds into payload	-0.015	[mW]
via radiation from CTCE lower-shroud baffle into payload	-0.002	[mW]
via radiation from CTCE upper-shroud baffle into payload	-0.002	[mW]
via radiation from CTCE reflector into payload	2.651	[mW]
via radiation from CVV-LOU-Window onto HIFI-Baffle	19.952	[mW]
via radiation from CVV-LOU-Window onto HIFI-FPU	14.512	[mW]
Vent line cooling power (out of payload)	103.667	[mW]
Transferred by convection from PL-ventline on helium	103.722	[mW]
total dissipation of PACS	5.070	[mW]
total dissipation of SPIRE	21.167	[mW]
total dissipation of HIFI	16.867	[mW]
Harness dissipation on OB	4.462	[mW]
Payload Heat Imbalance (shall be 0)	-1.533	[mW]

Heat Balance for Main Tank Ventline

=====		
conducted and radiated into ventline attached to HS1	3204.711	[mW]
conducted and radiated into ventline attached to HS2	5791.142	[mW]
conducted and radiated into ventline attached to HS3 +Z	19180.000	[mW]
conducted and radiated into ventline attached to HS3 -Z	19154.160	[mW]
conducted into ventline walls from CVV	56931.238	[mW]
conducted and radiated into line baf to HS 1	0.152	[mW]
Main Tank Ventline cooling power (out of ventline)	104261.505	[mW]
Via convection into ventline walls	-104271.432	[mW]
Main Tank Ventline Imbalance (shall be 0)	-0.101	[mW]

Heat Balance for CTCE

=====		
Convective heat transfer onto CTCE-external insulation	27236.032	[mW]
Conducted from CVV into CTCE-structure	-276.497	[mW]
Radiated from Payload into CTCE-shrouds incl. baffles	0.019	[mW]
Radiated from HS-baffles onto CTCE-shroud	48.883	[mW]
Radiated from CVV flange disc within cavity onto CTCE-MLI	2061.649	[mW]
Radiated from Payload onto reflector	-2.651	[mW]
Conducted from CTCE-structure into CTCE-shrouds	40.000	[mW]
Cooling power of CTCE-shrouds	29107.424	[mW]
CTCE Imbalance (shall be 0)	0.011	[mW]

Heat Balance for Reflector within CTCE

=====		
via struts from CTCE-I/F brackets into reflector	-11.020	[mW]
by radiation from CTCE-shrouds into reflector	-26.316	[mW]
by radiation from Payload into reflector	-2.651	[mW]
reflector heater power	40.000	[mW]
reflector total imbalance (shall be 0)	0.012	[mW]

Heat Balance for whole Cryostat including Payload, Ventlines and CTCE

=====		
Convective heat transfer onto external walls	133270.748	[mW]
total heat transferred on gaseous helium	133472.596	[mW]
evaporation power in main and aux. tank	2087.135	[mW]
Total instrument power dissipation	43.104	[mW]
total main & auxiliary tank and reflector heater power	2054.000	[mW]
heater power of CVV lower bulkhead HTR	0.000	[mW]
total harness dissipation within system	19.601	[mW]
Cooling power of CTCE-shrouds	29107.424	[mW]
Cryostat total imbalance (shall be 0)	-172.278	[mW]

Heat Balance for Main Tank

=====

Main tank dissipation + heater power	2000.000 [mW]
heat from Aux. tank via mech. I/F	-0.451 [mW]
radiated from aux. tank	0.000 [mW]
conducted from spatial framework	30.989 [mW]
transferred through MLI	9.751 [mW]
conducted from rest	0.290 [mW]
radiated from spatial framework and HSs	0.077 [mW]
conducted from main tank ventline wall	0.000 [mW]
radiated from payload	0.000 [mW]
total heat into main tank	2040.655 [mW]

Heat Balance for Auxiliary Tank

=====

Aux. tank dissipation + heater power	14.000 [mW]
heat from Main tank via mech. I/F	0.451 [mW]
radiated from Main tank	0.000 [mW]
radiated from spatial framework and HSs	0.015 [mW]
conducted from payload L0	16.236 [mW]
conducted from payload L2	0.065 [mW]
radiated from payload	0.013 [mW]
conducted from filling tube	0.007 [mW]
radiated from MLI filling tube	15.692 [mW]
total heat into Aux. tank	46.480 [mW]

Heat flows into Tanks

=====

Into Main Tank	2040.655 [mW]
Into Aux. Tank	46.480 [mW]

Helium evaporation mass flow rates

=====

Out of Main Tank	97.546 [mg/s]
Out of Aux. Tank	2.039 [mg/s]
Out of external He- dewar for CTA-shroud cooling	100.000 [mg/s]

5.4 CTCE-Design-2 Case 2 b

CTCE-design2 means: Radiative and vapor-cooled heatshield-design concept without any MLI for CTCE as defined in § 4.5.2.2

Case 2 b means: EQM-aux. Tank heater power = 14 mW
 CTCE-shroud He-mass flow rate = 150 mg/s
 Reflector heater power = 50 mW

The input parameters are compiled in Table 5-13 and a brief temperature results summary is given in Table 5-15. The complete ESATAN-output-file listing is appended. The respective node numbers and labels are referenced in the thermal design and thermal-mathematical model descriptions in § 4

Input parameter	
Main Tank temperature	4.2 K
EQM-aux. Tank temperature	1.7 K
External Hel dewar temp. for CTCE-shroud cooling	4.2 K
Main Tank heater power	2000 mW
EQM-auxiliary tank heater power	14 mW
CTCE-shroud He-mass flow rate	150 mg/s
Reflector heater power	50 mW

Table 5-13: Input parameters

Submodel	Node #	Node Label	T (K)	T _{max} (K) required	Requirement fulfilled
CRYO	12, 22, 32	Heatshield 1	10 – 16	NA	NA
CRYO	13, 23, 33	Heatshield 2	23 – 38	NA	NA
CRYO	14, 15, 24, 25, 34, 35	Heatshield 3	98 – 143	NA	NA
CRYO	4001 - 4078	CVV	293	NA	NA
CRYO	4090	LOU window	290	NA	NA
CRYO:PLM	371 - 381	Optical Bench	11 – 12	15	yes

Submodel	Node #	Node Label	T (K)	T _{max} (K) required	Requirement fulfilled
CRYO:PLM	811	SPIRE SM Detector enclosure	1.78	1.8	yes
CRYO:PLM	819	SPIRE Cooler Pump HS	1.78	1.8	yes
CRYO:PLM	820	SPIRE Cooler Evaporator HS	1.73	1.8	yes
CRYO:PLM	765	PACS Blue Detector	1.72	3.5	yes
CRYO:PLM	760	PACS Red Detector	1.70	1.75	yes
CRYO:PLM	781	PACS He-Pump	1.78	2.20	yes
CRYO:PLM	912	HIFI I0-Boundary	1.86	2.00	yes
CRYO:PLM	803	SPIRE Optical Bench	5.3	4.5	No 1)
CRYO:PLM	730	PACS Photometer Optics	3.2	5	yes
CRYO:PLM	725	PACS Collimator	3.2	5	yes
CRYO:PLM	720	PACS Spectrom. Housing	3.2	5	yes
CRYO:PLM	913	HIFI L1-interface	6.1	6	No 2)
CRYO:PLM	801	SPIRE PM JFET enclosure	12	13	yes
CRYO:PLM	802	SPIRE SM JFET enclosure	12	13	yes
CRYO:PLM	910	HIFI FPU Structure	12	13	yes
CTCE	901 -930	CTCE vessel	292	NA	NA
CTCE	1221 - 1230	CTA-shroud	4.4 – 4.8	5	yes
CTCE	1121 – 1130	CTA- heatshield	47 – 66	NA	NA
CTCE	1240	CTA-Reflector	88	40 -80	No *)
CTCE	1250, 1260, 1270	Reflector interface brackets (or optical bench)	18 – 21	NA	NA
		Mass-flow rate (mg/s)	required mass-flow rate (mg/s)	Requirement fulfilled	
Out of main tank		98	NA**)	NA	
Out of EQM-auxiliary tank		2.0	2.1	yes	
Out of external He-dewar for CTA-shroud cooling		150	NA **)	NA	

1) requirement not yet approved by ASED

2) can be fulfilled b slightly increasing the mass flow rate to 2.1 mg/s.

*) can easily be controlled at lower temperature by reducing electrical heater power

***) to be verified whether pressure drop is not too high

Table 5-15: Brief results summary

EUROPEAN SPACE AGENCY THERMAL ANALYSIS NETWORK

(VERSION 8.5.0)

PAGE 1

21 FEBRUARY 2002

10:23:41

```
#####
# EQM5: CTA with radiatively and vapor-cooled heatshields without any MLI
#
# Main Tank heater power:      2000 mW
# Aux. Tank heater power:      14 mW
# CTCE-shroud mass flow rate:  150 mg/s
# Reflector HTR power:         50 mW
#
#####
```

+EQM5

NODE	LABEL	T	QI	QR	C
9999	AMBIENT	293.000	0.00000	0.00000	0.000
1	MAIN TANK	4.200	0.00000	2.00000	0.000
2	AUX TANK	1.700	0.00000	0.01400	0.000
5	Ti-head lo 5	11.289	0.00000	0.00000	71.103
6	belt fitting lo 6	10.681	0.00000	0.00000	63.273
7	strut tank end lo 7	4.359	0.00000	0.00000	21.852
8	Ti-head up 8	11.466	0.00000	0.00000	72.602
9	belt fitting up 9	10.858	0.00000	0.00000	64.733
10	strut tank end up 10	4.367	0.00000	0.00000	21.892
12	HS 1 BULK 12	10.595	0.00000	0.00000	14.047
13	HS 2 BULK 13	22.973	0.00000	0.00000	139.980
14	HS 3 BULK +Z 14	119.552	0.00000	0.00000	2767.890
15	HS 3 BULK -Z 15	119.518	0.00000	0.00000	2767.248
22	HS 1 CYL 22	10.521	0.00000	0.00000	44.722
23	HS 2 CYL 23	21.960	0.00000	0.00000	330.208
24	HS 3 CYL +Z 24	97.599	0.00000	0.00000	6858.268
25	HS 3 CYL -Z 25	97.497	0.00000	0.00000	6848.963
32	HS 1 CONE 32	15.542	0.00000	0.00000	91.882
33	HS 2 CONE 33	37.992	0.00000	0.00000	1509.405
34	HS 3 CONE +Z 34	142.307	0.00000	0.00000	7727.312
35	HS 3 CONE -Z 35	142.513	0.00000	0.00000	7727.312
42	HS 1 HIFI Baf. int.	25.653	0.00000	0.00000	2.931
52	HS 1 HIFI Baf. ext.	32.982	0.00000	0.00000	2.676
53	HS 2 HIFI Baf.	57.583	0.00000	0.00000	10.625
54	HS 3 HIFI Baf.	175.249	0.00000	0.00000	45.566
62	HS 1 Tele BAF	15.570	0.00000	0.00000	0.346
63	HS 2 Tele BAF	38.179	0.00000	0.00000	5.541
64	HS 3 Tele BAF	142.213	0.00000	0.00000	81.093
101	MLI MAIN TANK LO 101	5.167	0.00000	0.00000	15.687
105	MLI MAIN TANK CY 105	4.734	0.00000	0.00000	43.337
106	MLI MAIN TANK UP 106	37.068	0.00000	0.00000	112.530
112	MLI HS 1 BULK 112	20.318	0.00000	0.00000	39.938
113	MLI HS 2 BULK 113	115.106	0.00000	0.00000	381.960
114	MLI HS 3 BULK +Z 114	287.452	0.00000	0.00000	706.439
115	MLI HS 3 BULK -Z 115	287.428	0.00000	0.00000	706.381
122	MLI HS 1 CYL 122	19.252	0.00000	0.00000	122.980
123	MLI HS 2 CYL 123	93.730	0.00000	0.00000	969.166
124	MLI HS 3 CYL +Z 124	286.652	0.00000	0.00000	2100.815
125	MLI HS 3 CYL -Z 125	285.594	0.00000	0.00000	2093.062
132	MLI HS 1 CONE 132	51.497	0.00000	0.00000	249.804
133	MLI HS 2 CONE 133	137.795	0.00000	0.00000	1125.590
134	MLI HS 3 CONE +Z 134	287.262	0.00000	0.00000	1701.879

135	MLI HS 3 CONE -Z	135	287.242	0.00000	0.00000	1701.760
440	filling tube	440	271.512	0.00000	0.00000	0.000
441	filling tube	441	252.212	0.00000	0.00000	0.000
442	filling tube	442	245.509	0.00000	0.00000	0.000
443	filling tube	443	242.449	0.00000	0.00000	0.000
447	empty tube	447	15.530	0.00000	0.00000	0.000
452	empty tube	452	10.866	0.00000	0.00000	0.000
502	line baf to HS1	502	4.201	0.00000	0.00000	0.000
642	MLI filling tube	642	120.434	0.00000	0.00000	0.766
643	MLI filling tube	643	119.015	0.00000	0.00000	0.743
647	MLI filling tube	647	25.815	0.00000	0.00000	1.245
652	MLI filling tube	652	23.549	0.00000	0.00000	0.459
1000	HS 1 SUSP BOLT	1000	19.628	0.00000	0.00000	0.000
2000	HS 2 SUSP BOLT	2000	67.886	0.00000	0.00000	0.000
3000	HS 3 SUSP BOLT	3000	189.809	0.00000	0.00000	0.000
4001	CVV lower bulk	4001	292.764	0.00000	0.00000	4399.464
4002	CVV lower bulk	4002	292.771	0.00000	0.00000	4399.491
4003	CVV lower bulk	4003	292.771	0.00000	0.00000	4399.491
4004	CVV lower bulk	4004	292.764	0.00000	0.00000	4399.462
4005	CVV lower bulk	4005	292.750	0.00000	0.00000	4399.407
4006	CVV lower bulk	4006	292.749	0.00000	0.00000	4399.404
4007	CVV lower bulk	4007	292.758	0.00000	0.00000	4399.441
4008	CVV lower bulk	4008	292.760	0.00000	0.00000	4399.449
4011	CVV lower bulk	4011	292.707	0.00000	0.00000	1668.975
4012	CVV lower bulk	4012	292.740	0.00000	0.00000	1669.025
4013	CVV lower bulk	4013	292.741	0.00000	0.00000	1669.028
4014	CVV lower bulk	4014	292.717	0.00000	0.00000	1668.991
4015	CVV lower bulk	4015	292.654	0.00000	0.00000	1668.893
4016	CVV lower bulk	4016	292.654	0.00000	0.00000	1668.894
4017	CVV lower bulk	4017	292.705	0.00000	0.00000	1668.971
4018	CVV lower bulk	4018	292.700	0.00000	0.00000	1668.964
4031	CVV cyl lower	4031	292.553	0.00000	0.00000	13706.677
4032	CVV cyl lower	4032	292.660	0.00000	0.00000	13708.037
4033	CVV cyl lower	4033	292.663	0.00000	0.00000	13708.072
4034	CVV cyl lower	4034	292.599	0.00000	0.00000	13707.261
4035	CVV cyl lower	4035	292.392	0.00000	0.00000	13704.650
4036	CVV cyl lower	4036	292.397	0.00000	0.00000	13704.709
4037	CVV cyl lower	4037	292.568	0.00000	0.00000	13706.875
4038	CVV cyl lower	4038	292.537	0.00000	0.00000	13706.477
4041	CVV cyl upper	4041	292.693	0.00000	0.00000	19514.587
4042	CVV cyl upper	4042	292.698	0.00000	0.00000	19514.675
4043	CVV cyl upper	4043	292.632	0.00000	0.00000	19513.493
4044	CVV cyl upper	4044	292.215	0.00000	0.00000	19505.999
4045	CVV cyl upper	4045	289.660	0.00000	0.00000	19460.089
4046	CVV cyl upper	4046	289.655	0.00000	0.00000	19459.994
4047	CVV cyl upper	4047	292.186	0.00000	0.00000	19505.469
4048	CVV cyl upper	4048	292.602	0.00000	0.00000	19512.958
4051	CVV upper bulk	4051	292.694	0.00000	0.00000	19050.624
4052	CVV upper bulk	4052	292.608	0.00000	0.00000	19049.101
4053	CVV upper bulk	4053	292.598	0.00000	0.00000	19048.936
4054	CVV upper bulk	4054	292.650	0.00000	0.00000	19049.845
4055	CVV upper bulk	4055	292.570	0.00000	0.00000	19048.435
4056	CVV upper bulk	4056	292.525	0.00000	0.00000	19047.658
4057	CVV upper bulk	4057	292.661	0.00000	0.00000	19050.041
4058	CVV upper bulk	4058	292.700	0.00000	0.00000	19050.719
4061	CVV/CTA flange	4061	292.123	0.00000	0.00000	0.000
4062	CVV/CTA flange	4062	292.101	0.00000	0.00000	0.000
4063	CVV/CTA flange	4063	292.080	0.00000	0.00000	0.000
4064	CVV/CTA flange	4064	292.058	0.00000	0.00000	0.000
4065	CVV/CTA flange	4065	292.034	0.00000	0.00000	0.000
4066	CVV/CTA flange	4066	292.039	0.00000	0.00000	0.000
4067	CVV/CTA flange	4067	292.092	0.00000	0.00000	0.000
4068	CVV/CTA flange	4068	292.120	0.00000	0.00000	0.000

4071	CVV flange disc	4071	291.924	0.00000	0.00000	0.000
4072	CVV flange disc	4072	291.911	0.00000	0.00000	0.000
4073	CVV flange disc	4073	291.894	0.00000	0.00000	0.000
4074	CVV flange disc	4074	291.877	0.00000	0.00000	0.000
4075	CVV flange disc	4075	291.864	0.00000	0.00000	0.000
4076	CVV flange disc	4076	291.871	0.00000	0.00000	0.000
4077	CVV flange disc	4077	291.899	0.00000	0.00000	0.000
4078	CVV flange disc	4078	291.920	0.00000	0.00000	0.000
4090	CVV Lo window		289.911	0.00000	0.00000	15.603
4631	SUSP TI lo	4631	282.781	0.00000	0.00000	84.266
4632	SUSP TI lo	4632	282.880	0.00000	0.00000	84.277
4633	SUSP TI lo	4633	282.882	0.00000	0.00000	84.277
4634	SUSP TI lo	4634	282.823	0.00000	0.00000	84.271
4635	SUSP TI lo	4635	282.633	0.00000	0.00000	84.250
4636	SUSP TI lo	4636	282.637	0.00000	0.00000	84.251
4637	SUSP TI lo	4637	282.795	0.00000	0.00000	84.268
4638	SUSP TI lo	4638	282.766	0.00000	0.00000	84.265
4641	SUSP TI up	4641	282.910	0.00000	0.00000	84.280
4642	SUSP TI up	4642	282.914	0.00000	0.00000	84.280
4643	SUSP TI up	4643	282.854	0.00000	0.00000	84.274
4644	SUSP TI up	4644	282.470	0.00000	0.00000	84.233
4645	SUSP TI up	4645	280.120	0.00000	0.00000	83.983
4646	SUSP TI up	4646	280.115	0.00000	0.00000	83.982
4647	SUSP TI up	4647	282.443	0.00000	0.00000	84.230
4648	SUSP TI up	4648	282.826	0.00000	0.00000	84.271
4731	CABLE PLUG	4731	281.499	0.00073	0.00000	93.529
4732	CABLE PLUG	4732	291.588	0.00000	0.00000	97.058
4733	CABLE PLUG	4733	291.591	0.00000	0.00000	97.059
4734	CABLE PLUG	4734	291.527	0.00000	0.00000	97.036
4735	CABLE PLUG	4735	291.321	0.00000	0.00000	96.964
4736	CABLE PLUG	4736	292.397	0.00000	0.00000	97.341
4737	CABLE PLUG	4737	292.568	0.00000	0.00000	97.401
4738	CABLE PLUG	4738	283.622	0.00010	0.00000	94.271
6051	X2 SI Harness	51	245.203	0.00073	0.00000	0.000
6052	X2 SI Harness	52	205.934	0.00073	0.00000	0.000
6053	X2 SI Harness	53	162.824	0.00073	0.00000	0.000
6054	X2 SI Harness	54	113.892	0.00073	0.00000	0.000
6055	X2 SI at HS1	55	50.556	0.00250	0.00000	0.000
6056	X3 SI Harness	56	45.816	0.00250	0.00000	0.000
6057	X3 SI Harness	57	39.342	0.00250	0.00000	0.000
6058	X3 SI Harness	58	30.006	0.00250	0.00000	0.000
6061	X2 JF Harness	61	246.339	0.00010	0.00000	0.000
6062	X2 JF Harness	62	205.932	0.00010	0.00000	0.000
6063	X2 JF Harness	63	161.456	0.00010	0.00000	0.000
6064	X2 JF Harness	64	110.711	0.00010	0.00000	0.000
6065	X2 JF at HS1	65	42.549	0.00024	0.00000	0.000
6066	X3 JF Harness	66	38.154	0.00024	0.00000	0.000
6067	X3 JF Harness	67	33.084	0.00024	0.00000	0.000
6068	X3 JF Harness	68	26.938	0.00024	0.00000	0.000
9999	AMBIENT		293.000	0.00000	0.00000	0.000

+EQM5:CRYO:V

NODE		LABEL	T	QI	QR	C
201	OSS-TUBE	201	4.200	0.00000	0.00000	0.000
202	BAFFLE LO	202	4.200	0.00000	0.00000	0.000
203	BAFFLE UP	203	4.200	0.00000	0.00000	0.000
204	1ST HS	204	10.521	0.00000	0.00000	0.000
205	2ND HS	205	21.960	0.00000	0.00000	0.000
206	3RD HS +z	206	97.599	0.00000	0.00000	0.000
207	3RD HS -z	207	97.497	0.00000	0.00000	0.000
210	VENT VESSEL	210	209.866	0.00000	0.00000	0.000
212	BAFFLE - 1ST HS	212	4.201	0.00000	0.00000	0.000
251	TANK HE-OUT	251	4.200	0.00000	0.00000	0.000
252	OSS HE-OUT	252	4.200	0.00000	0.00000	0.000
253	BAFFLE LO HE-OUT	253	4.200	0.00000	0.00000	0.000
254	BAFFLE UP HE-OUT	254	4.200	0.00000	0.00000	0.000
255	1ST HS HE-OUT	255	10.521	0.00000	0.00000	0.000
256	2ND HS HE-OUT	256	21.940	0.00000	0.00000	0.000
257	3RD HS HE-OUT	257	97.548	0.00000	0.00000	0.000
260	VESSEL HE-OUT	260	209.866	0.00000	0.00000	0.000
262	BAF - HS1 HE-OUT	262	4.200	0.00000	0.00000	0.000
296	HEATER WALL	296	293.000	0.00000	0.00000	0.000
297	HEATER HE-OUT	297	209.866	0.00000	0.00000	0.000

=====

+EQM5:CRYO:PLM

NODE	LABEL	T	QI	QR	C
310	Instr. Shield Cyl.	11.728	0.00000	0.00000	8.465
311	Instr. Shield Top	11.754	0.00000	0.00000	10.993
315	Instr. Shield Baffle	11.789	0.00000	0.00000	0.713
320	Vline wall Tank-PACS	1.755	0.00000	0.00000	0.007
321	Vline wall PACS I/F 1	2.394	0.00000	0.00000	0.001
322	Vline wall PACS I/F 1	2.641	0.00000	0.00000	0.000
323	Vline wall PACS I/F 1	2.476	0.00000	0.00000	0.001
324	Vline wall PACSI/F1/2	2.306	0.00000	0.00000	0.003
325	Vline wall PACSI/F1/2	2.335	0.00000	0.00000	0.013
326	Vline wall PACS I/F 2	2.707	0.00000	0.00000	0.001
327	Vline wall PACS I/F 2	2.859	0.00000	0.00000	0.000
328	Vline wall PACS I/F 2	2.769	0.00000	0.00000	0.001
329	Vline wall PACSI/F2/3	2.678	0.00000	0.00000	0.006
330	Vline wall PACSI/F2/3	2.743	0.00000	0.00000	0.002
331	Vline wall PACS I/F 3	2.876	0.00000	0.00000	0.001
332	Vline wall PACS I/F 3	2.982	0.00000	0.00000	0.000
333	Vline wall PACS I/F 3	2.934	0.00000	0.00000	0.001
334	Vline wall PACS-SPIRE	2.891	0.00000	0.00000	0.006
335	Vline wall PACS-SPIRE	2.913	0.00000	0.00000	0.007
336	Vline wall PACS-SPIRE	3.083	0.00000	0.00000	0.008
337	Vline wall SPIRE	4.095	0.00000	0.00000	0.001
338	Vline wall SPIRE	4.685	0.00000	0.00000	0.001
339	Vline wall SPIRE	4.412	0.00000	0.00000	0.001
340	Vline wall SPIRE-HIFI	4.191	0.00000	0.00000	0.012
341	Vline wall SPIRE-HIFI	4.204	0.00000	0.00000	0.015
342	Vline wall SPIRE-HIFI	4.313	0.00000	0.00000	0.018
343	Vline wall HIFI	5.271	0.00000	0.00000	0.002
344	Vline wall HIFI	5.839	0.00000	0.00000	0.001
345	Vline wall HIFI	6.152	0.00000	0.00000	0.003
346	Vline Lev.2 OB	10.253	0.00000	0.00000	0.074
347	Vline Lev.2 OB	11.319	0.00000	0.00000	0.212
348	Vline Lev.2 OB	11.435	0.00000	0.00000	0.085
349	Vline Lev.2 OB	11.503	0.00000	0.00000	0.135
350	Vline Lev.2 OB	11.530	0.00000	0.00000	0.080
351	Vline Lev.2 OB	11.535	0.00000	0.00000	0.235
352	Vline Lev.2 OB	11.559	0.00000	0.00000	0.121
371	Opt. Bench +Z	11.451	0.00000	0.00000	8.062
372	Opt. Bench +Z -Y	11.380	0.00000	0.00000	7.324
373	Opt. Bench +Z mid	11.461	0.00000	0.00000	18.950
374	Opt. Bench +Z +Y	11.479	0.00000	0.00000	3.069
375	Opt. Bench -Y	11.526	0.00000	0.00000	14.004
376	Opt. Bench centre	11.510	0.00000	0.00000	33.741
377	Opt. Bench +Y	11.516	0.00000	0.00000	7.433
378	Opt. Bench -Z -Y	11.561	0.00000	0.00000	7.651
379	Opt. Bench -Z mid	11.538	0.00000	0.00000	19.298
380	Opt. Bench -Z +Y	11.540	0.00000	0.00000	3.114
381	Opt. Bench -Z	11.535	0.00000	0.00000	8.226
390	I.Shld HIFI Baf. ext.	11.800	0.00000	0.00000	0.332
391	I.Shld HIFI Baf. int.	11.732	0.00000	0.00000	0.116
411	MLI on OB-Shield side	13.960	0.00000	0.00000	31.764
412	MLI on OB-Shield top	13.971	0.00000	0.00000	41.034
710	PACS-Top Optic	3.161	0.00000	0.00000	1.890
720	PACS-Spectrometer	3.158	0.00003	0.00000	2.137
725	PACS-Collimator	3.156	0.00000	0.00000	2.160
730	PACS-Photometer Optic	3.155	0.00000	0.00000	1.305
735	PACS-Internal	3.159	0.00000	0.00000	1.812
740	PACS-Lump	3.159	0.00000	0.00000	0.000
750	PACS-Chopper	3.163	0.00040	0.00000	0.114

755	PACS-Grating Assy	3.163	0.00100	0.00000	0.778
760	PACS-Red Detector	1.704	0.00000	0.00000	0.230
761	PACS-Red Detect. CRE	3.170	0.00030	0.00000	0.029
765	PACS-Blue Detector	1.723	0.00013	0.00000	0.233
766	PACS-Blue Detect. CRE	3.170	0.00030	0.00000	0.029
770	PACS-Filter Wh. Blue	3.159	0.00004	0.00000	0.133
771	PACS-Filter Wh. Photo	3.155	0.00004	0.00000	0.132
775	PACS-Calib. Source 1	3.161	0.00032	0.00000	0.019
776	PACS-Calib. Source 2	3.164	0.00032	0.00000	0.019
780	PACS-Photometer Housi	3.157	0.00000	0.00000	1.001
781	PACS-Photometer CooPu	1.781	0.00220	0.00000	0.147
791	PACS-STST-Strut 1,1	9.320	0.00000	0.00000	0.331
792	PACS-STST-Strut 4,1	9.316	0.00000	0.00000	0.515
793	PACS-STST-Strut 5,1	9.320	0.00000	0.00000	0.258
794	PACS-Kevlar-Strut Red 1	2.616	0.00000	0.00000	0.014
795	PACS-Kevlar-Strut Blue 1	2.620	0.00000	0.00000	0.014
796	PACS-HarnessRed Det.Intl	2.550	0.00000	0.00000	0.000
797	PACS-HarnessBlueDet.Intl	2.557	0.00000	0.00000	0.000
798	PACS-HarnessBlue1.7->4,1	2.541	0.00000	0.00000	0.000
801	SPIRE PM JFET ENCL	11.568	0.01026	0.00000	11.674
802	SPIRE SM JFET ENCL	11.543	0.00282	0.00000	3.788
803	SPIRE Optical Bench	5.332	0.00000	0.00000	10.994
804	SPIRE RF Filter Box	5.337	0.00428	0.00000	0.538
805	SPIRE Beam St. Mech	5.333	0.00100	0.00000	0.403
806	SPIRE SMECm	5.333	0.00048	0.00000	0.477
807	SPIRE PM calibrator	5.333	0.00002	0.00000	0.000
808	SPIRE SM calibrator	9.599	0.00040	0.00000	0.000
809	SPIRE Shutter	5.332	0.00000	0.00000	0.000
810	SPIRE PM Detector en	1.805	0.00000	0.00000	0.454
811	SPIRE SM Detector en	1.780	0.00000	0.00000	0.270
812	SPIRE PM Detectors	1.744	0.00000	0.00000	0.398
813	SPIRE SM detector	1.744	0.00000	0.00000	0.253
816	SPIRE Cooler Pump	1.888	0.00183	0.00000	0.000
817	SPIRE Cooler shunt	1.726	0.00000	0.00000	0.000
818	SPIRE Cooler evap	1.744	0.00000	0.00000	0.000
819	SPIRE Cooler pump HS	1.775	0.00008	0.00000	0.000
820	SPIRE Cooler evap HS	1.726	0.00000	0.00000	0.000
900	HIFI 2K level	1.862	0.00014	0.00000	0.030
905	HIFI Harness 1 int.point	6.084	0.00036	0.00000	0.000
910	HIFI FPU Structure	11.540	0.01602	0.00000	110.051
912	HIFI L0 boundary node	1.855	0.00000	0.00000	0.000
913	HIFI L1 boundary node	6.099	0.00000	0.00000	0.000
914	HIFI Harness 2a int.poin	12.762	0.00036	0.00000	0.000
915	HIFI Harness 2b int.poin	9.224	0.00000	0.00000	0.000
920	HIFI Internal Assy.	6.104	0.00000	0.00000	0.026
5000	GHe tank outlet	1.700	0.00000	0.00000	0.000
5010	GHe PACS I/F 1 in	1.752	0.00000	0.00000	0.000
5011	GHe PACS I/F 1	1.965	0.00000	0.00000	0.000
5012	GHe PACS I/F 1	2.101	0.00000	0.00000	0.000
5013	GHe PACS I/F 1 out	2.233	0.00000	0.00000	0.000
5014	GHe PACS I/F 1/2	2.288	0.00000	0.00000	0.000
5020	GHe PACS I/F 2 in	2.333	0.00000	0.00000	0.000
5021	GHe PACS I/F 2	2.472	0.00000	0.00000	0.000
5022	GHe PACS I/F 2	2.558	0.00000	0.00000	0.000
5023	GHe PACS I/F 2 out	2.639	0.00000	0.00000	0.000
5024	GHe PACS I/F 2/3	2.674	0.00000	0.00000	0.000
5030	GHe PACS I/F 3 in	2.720	0.00000	0.00000	0.000
5031	GHe PACS I/F 3	2.782	0.00000	0.00000	0.000
5032	GHe PACS I/F 3	2.828	0.00000	0.00000	0.000
5033	GHe PACS I/F 3 out	2.871	0.00000	0.00000	0.000
5034	GHe PACS-SPIRE	2.889	0.00000	0.00000	0.000
5035	GHe PACS-SPIRE	2.912	0.00000	0.00000	0.000
5040	GHe SPIRE I/F in	3.074	0.00000	0.00000	0.000

5041	GHe SPIRE I/F	3.552	0.00000	0.00000	0.000
5042	GHe SPIRE I/F	3.881	0.00000	0.00000	0.000
5043	GHe SPIRE I/F out	4.144	0.00000	0.00000	0.000
5044	GHe SPIRE-HIFI	4.189	0.00000	0.00000	0.000
5045	GHe SPIRE-HIFI	4.204	0.00000	0.00000	0.000
5050	GHe HIFI I/F in	4.308	0.00000	0.00000	0.000
5051	GHe HIFI I/F	4.819	0.00000	0.00000	0.000
5052	GHe HIFI I/F	5.157	0.00000	0.00000	0.000
5053	GHe HIFI I/F out	5.729	0.00000	0.00000	0.000
5054	GHe Lev.2 OB	10.028	0.00000	0.00000	0.000
5055	GHe Lev.2 OB	11.255	0.00000	0.00000	0.000
5056	GHe Lev.2 OB	11.426	0.00000	0.00000	0.000
5057	GHe Lev.2 OB	11.499	0.00000	0.00000	0.000
5058	GHe Lev.2 OB	11.529	0.00000	0.00000	0.000
5059	GHe Lev.2 OB	11.534	0.00000	0.00000	0.000
5060	GHe Lev.2 OB	11.557	0.00000	0.00000	0.000
6059	X3 SI Harness 59	12.389	0.00406	0.00000	0.000
6069	X3 JF Harness 69	18.741	0.00040	0.00000	0.000
9999	Ambient Air	293.000	0.00000	0.00000	0.000

+EQM5:CTCE

NODE	LABEL	T	QI	QR	C
901	vessel flange 901	292.124	0.00000	0.00000	905.487
902	vessel flange 902	292.106	0.00000	0.00000	905.472
903	vessel flange 903	292.082	0.00000	0.00000	905.452
904	vessel flange 904	292.046	0.00000	0.00000	905.422
905	vessel flange 905	292.023	0.00000	0.00000	905.403
906	vessel flange 906	292.033	0.00000	0.00000	905.412
907	vessel flange 907	292.090	0.00000	0.00000	905.459
908	vessel flange 908	292.120	0.00000	0.00000	905.484
921	cyl. vessel 921	292.129	0.00000	0.00000	8549.561
922	cyl. vessel 922	292.119	0.00000	0.00000	8549.482
923	cyl. vessel 923	292.062	0.00000	0.00000	8549.034
924	cyl. vessel 924	291.877	0.00000	0.00000	8547.579
925	cyl. vessel 925	291.835	0.00000	0.00000	8547.243
926	cyl. vessel 926	291.877	0.00000	0.00000	8547.580
927	cyl. vessel 927	292.063	0.00000	0.00000	8549.042
928	cyl. vessel 928	292.120	0.00000	0.00000	8549.492
930	vessel dome 930	292.106	0.00000	0.00000	19141.380
1011	CTA HS1 bottom	43.105	0.00000	0.00000	0.000
1012	CTA HS1 bottom	43.101	0.00000	0.00000	0.000
1013	CTA HS1 bottom	43.102	0.00000	0.00000	0.000
1014	CTA HS1 bottom	43.112	0.00000	0.00000	0.000
1015	CTA HS1 bottom	43.121	0.00000	0.00000	0.000
1016	CTA HS1 bottom	43.128	0.00000	0.00000	0.000
1017	CTA HS1 bottom	43.128	0.00000	0.00000	0.000
1018	CTA HS1 bottom	43.119	0.00000	0.00000	0.000
1021	CTA HS1 cyl.	43.082	0.00000	0.00000	0.000
1022	CTA HS1 cyl.	43.087	0.00000	0.00000	0.000
1023	CTA HS1 cyl.	43.081	0.00000	0.00000	0.000
1024	CTA HS1 cyl.	43.107	0.00000	0.00000	0.000
1025	CTA HS1 cyl.	43.118	0.00000	0.00000	0.000
1026	CTA HS1 cyl.	43.136	0.00000	0.00000	0.000
1027	CTA HS1 cyl.	43.133	0.00000	0.00000	0.000
1028	CTA HS1 cyl.	43.120	0.00000	0.00000	0.000
1030	CTA HS1 top	43.147	0.00000	0.00000	0.000
1121	CTA HS2 cyl. 1121	47.604	0.00000	0.00000	203.115
1122	CTA HS2 cyl. 1122	46.673	0.00000	0.00000	193.075
1123	CTA HS2 cyl. 1122	49.442	0.00000	0.00000	222.921
1124	CTA HS2 cyl. 1122	53.004	0.00000	0.00000	261.316
1125	CTA HS2 cyl. 1122	56.597	0.00000	0.00000	300.036
1126	CTA HS2 cyl. 1122	59.306	0.00000	0.00000	329.239
1127	CTA HS2 cyl. 1122	60.452	0.00000	0.00000	341.799
1128	CTA HS2 cyl. 1122	58.004	0.00000	0.00000	315.199
1130	CTA HS2 top 1130	66.028	0.00000	0.00000	601.075
1201	CTA Shroud lo Baf	6.124	0.00000	0.00000	0.176
1211	CTA Shroud up Baf	4.780	0.00000	0.00000	0.100
1221	CTA cy.Shroud 1221	4.457	0.00000	0.00000	0.000
1222	CTA cy.Shroud 1222	4.415	0.00000	0.00000	0.000
1223	CTA cy.Shroud 1223	4.478	0.00000	0.00000	0.000
1224	CTA cy.Shroud 1224	4.453	0.00000	0.00000	0.000
1225	CTA cy.Shroud 1225	4.517	0.00000	0.00000	0.000
1226	CTA cy.Shroud 1226	4.492	0.00000	0.00000	0.000
1227	CTA cy.Shroud 1227	4.552	0.00000	0.00000	0.000
1228	CTA cy.Shroud 1228	4.506	0.00000	0.00000	0.000
1230	CTA topShroud 1230	4.790	0.00000	0.00000	0.619
1240	CTA Reflector	87.630	0.00000	0.05000	1173.727
1250	Refl. I/F bracket 1	17.797	0.00000	0.00000	0.000
1252	Refl. I/F br.1 pos.2	168.420	0.00000	0.00000	0.000
1253	Refl. I/F br.1 pos.3	169.783	0.00000	0.00000	0.000

1254	Refl. I/F br.1 pos.4	137.402	0.00000	0.00000	0.000
1255	Refl. I/F br.1 pos.5	139.613	0.00000	0.00000	0.000
1256	Refl. I/F br.1 pos.6	222.276	0.00000	0.00000	0.000
1257	Refl. I/F br.1 pos.7	224.000	0.00000	0.00000	0.000
1260	Refl. I/F bracket 2	19.450	0.00000	0.00000	0.000
1262	Refl. I/F br.2 pos.2	168.779	0.00000	0.00000	0.000
1263	Refl. I/F br.2 pos.3	170.139	0.00000	0.00000	0.000
1264	Refl. I/F br.2 pos.4	137.684	0.00000	0.00000	0.000
1265	Refl. I/F br.2 pos.5	139.889	0.00000	0.00000	0.000
1266	Refl. I/F br.2 pos.6	222.362	0.00000	0.00000	0.000
1267	Refl. I/F br.2 pos.7	224.083	0.00000	0.00000	0.000
1270	Refl. I/F bracket 3	21.141	0.00000	0.00000	0.000
1272	Refl. I/F br.3 pos.2	168.935	0.00000	0.00000	0.000
1273	Refl. I/F br.3 pos.3	170.291	0.00000	0.00000	0.000
1274	Refl. I/F br.3 pos.4	138.079	0.00000	0.00000	0.000
1275	Refl. I/F br.3 pos.5	140.278	0.00000	0.00000	0.000
1276	Refl. I/F br.3 pos.6	222.542	0.00000	0.00000	0.000
1277	Refl. I/F br.3 pos.7	224.259	0.00000	0.00000	0.000
1311	CTA HS3 bottom	255.658	0.00000	0.00000	0.000
1312	CTA HS3 bottom	255.657	0.00000	0.00000	0.000
1313	CTA HS3 bottom	255.645	0.00000	0.00000	0.000
1314	CTA HS3 bottom	255.644	0.00000	0.00000	0.000
1315	CTA HS3 bottom	255.639	0.00000	0.00000	0.000
1316	CTA HS3 bottom	255.649	0.00000	0.00000	0.000
1317	CTA HS3 bottom	255.655	0.00000	0.00000	0.000
1318	CTA HS3 bottom	255.664	0.00000	0.00000	0.000
1321	CTA HS3 cyl.	255.790	0.00000	0.00000	0.000
1322	CTA HS3 cyl.	255.849	0.00000	0.00000	0.000
1323	CTA HS3 cyl.	255.766	0.00000	0.00000	0.000
1324	CTA HS3 cyl.	255.811	0.00000	0.00000	0.000
1325	CTA HS3 cyl.	255.741	0.00000	0.00000	0.000
1326	CTA HS3 cyl.	255.821	0.00000	0.00000	0.000
1327	CTA HS3 cyl.	255.785	0.00000	0.00000	0.000
1328	CTA HS3 cyl.	255.861	0.00000	0.00000	0.000
1330	CTA HS3 top	256.925	0.00000	0.00000	0.000
2000	CTA-Shroud Dewar	4.200	0.00000	0.00000	0.000
2001	GHe Shroud 1221 out	4.234	0.00000	0.00000	0.000
2002	GHe Shroud 1222 out	4.257	0.00000	0.00000	0.000
2003	GHe Shroud 1223 out	4.286	0.00000	0.00000	0.000
2004	GHe Shroud 1224 out	4.308	0.00000	0.00000	0.000
2005	GHe Shroud 1225 out	4.336	0.00000	0.00000	0.000
2006	GHe Shroud 1226 out	4.356	0.00000	0.00000	0.000
2007	GHe Shroud 1227 out	4.382	0.00000	0.00000	0.000
2008	GHe Shroud 1228 out	4.399	0.00000	0.00000	0.000
2011	GHe HS 1121 out	22.946	0.00000	0.00000	0.000
2012	GHe HS 1122 out	31.069	0.00000	0.00000	0.000
2013	GHe HS 1123 out	37.719	0.00000	0.00000	0.000
2014	GHe HS 1124 out	43.527	0.00000	0.00000	0.000
2015	GHe HS 1125 out	48.683	0.00000	0.00000	0.000
2016	GHe HS 1126 out	52.965	0.00000	0.00000	0.000
2017	GHe HS 1127 out	56.024	0.00000	0.00000	0.000
2018	GHe HS 1128 out	56.831	0.00000	0.00000	0.000
2021	GHe I/F bracket 1250 out	6.643	0.00000	0.00000	0.000
2022	GHe I/F bracket 1260 out	8.885	0.00000	0.00000	0.000
2023	GHe I/F bracket 1270 out	11.121	0.00000	0.00000	0.000
9999	AMBIENT	293.000	0.00000	0.00000	0.000

Heat Balance for PAYLOAD incl. Instrument Shield MLI

=====		
Level 0: from Aux. Tank into instruments	-16.376	[mW]
Level 2: from spatial framework into OB	-0.751	[mW]
Level 1/2: from Aux. Tank into OB via ventline wall	-0.064	[mW]
Level 2: from HS1 into OB via ventline wall	0.152	[mW]
Level 2: via harness into OB	27.090	[mW]
via radiation from HS1 upper bulkhead onto Instrument MLI	0.225	[mW]
via radiation from Cryostat cavity onto OB lower side	5.126	[mW]
via radiation from HS1-baffle into payload	0.007	[mW]
via radiation from HS2-baffle into payload	0.023	[mW]
via radiation from HS3-baffle into payload	1.509	[mW]
via radiation from CTCE-4K-shrouds into payload	-0.016	[mW]
via radiation from CTCE lower-shroud baffle into payload	-0.002	[mW]
via radiation from CTCE upper-shroud baffle into payload	-0.002	[mW]
via radiation from CTCE reflector into payload	3.435	[mW]
via radiation from CVV-LOU-Window onto HIFI-Baffle	19.947	[mW]
via radiation from CVV-LOU-Window onto HIFI-FPU	14.509	[mW]
Vent line cooling power (out of payload)	104.778	[mW]
Transferred by convection from PL-ventline on helium	104.803	[mW]
total dissipation of PACS	5.070	[mW]
total dissipation of SPIRE	21.167	[mW]
total dissipation of HIFI	16.867	[mW]
Harness dissipation on OB	4.462	[mW]
Payload Heat Imbalance (shall be 0)	-2.399	[mW]

Heat Balance for Main Tank Ventline

=====		
conducted and radiated into ventline attached to HS1	3204.600	[mW]
conducted and radiated into ventline attached to HS2	5789.032	[mW]
conducted and radiated into ventline attached to HS3 +Z	19178.463	[mW]
conducted and radiated into ventline attached to HS3 -Z	19152.609	[mW]
conducted into ventline walls from CVV	56941.782	[mW]
conducted and radiated into line baf to HS 1	0.152	[mW]
Main Tank Ventline cooling power (out of ventline)	104266.691	[mW]
Via convection into ventline walls	-104276.644	[mW]
Main Tank Ventline Imbalance (shall be 0)	-0.052	[mW]

Heat Balance for CTCE

=====		
Convective heat transfer onto CTCE-external insulation	37835.264	[mW]
Conducted from CVV into CTCE-structure	142.094	[mW]
Radiated from Payload into CTCE-shrouds incl. baffles	0.020	[mW]
Radiated from HS-baffles onto CTCE-shroud	48.839	[mW]
Radiated from CVV flange disc within cavity onto CTCE-MLI	2953.528	[mW]
Radiated from Payload onto reflector	-3.435	[mW]
Conducted from CTCE-structure into CTCE-shrouds	50.000	[mW]
Cooling power of CTCE-shrouds	41025.563	[mW]
CTCE Imbalance (shall be 0)	0.748	[mW]

Heat Balance for Reflector within CTCE

=====		
via struts from CTCE-I/F brackets into reflector	-12.460	[mW]
by radiation from CTCE-shrouds into reflector	-34.088	[mW]
by radiation from Payload into reflector	-3.435	[mW]
reflector heater power	50.000	[mW]
reflector total imbalance (shall be 0)	0.017	[mW]

Heat Balance for whole Cryostat including Payload, Ventlines and CTCE

=====		
Convective heat transfer onto external walls	145184.516	[mW]
total heat transferred on gaseous helium	145397.031	[mW]
evaporation power in main and aux. tank	2087.536	[mW]
Total instrument power dissipation	43.104	[mW]
total main & auxiliary tank and reflector heater power	2064.000	[mW]
heater power of CVV lower bulkhead HTR	0.000	[mW]
total harness dissipation within system	19.601	[mW]
Cooling power of CTCE-shrouds	41025.563	[mW]
Cryostat total imbalance (shall be 0)	-173.346	[mW]

Heat Balance for Main Tank

=====

Main tank dissipation + heater power	2000.000 [mW]
heat from Aux. tank via mech. I/F	-0.451 [mW]
radiated from aux. tank	0.000 [mW]
conducted from spatial framework	31.256 [mW]
transferred through MLI	9.750 [mW]
conducted from rest	0.290 [mW]
radiated from spatial framework and HSs	0.077 [mW]
conducted from main tank ventline wall	0.000 [mW]
radiated from payload	0.000 [mW]
total heat into main tank	2040.921 [mW]

Heat Balance for Auxiliary Tank

=====

Aux. tank dissipation + heater power	14.000 [mW]
heat from Main tank via mech. I/F	0.451 [mW]
radiated from Main tank	0.000 [mW]
radiated from spatial framework and HSs	0.015 [mW]
conducted from payload L0	16.376 [mW]
conducted from payload L2	0.064 [mW]
radiated from payload	0.013 [mW]
conducted from filling tube	0.007 [mW]
radiated from MLI filling tube	15.689 [mW]
total heat into Aux. tank	46.615 [mW]

Heat flows into Tanks

=====

Into Main Tank	2040.921 [mW]
Into Aux. Tank	46.615 [mW]

Helium evaporation mass flow rates

=====

Out of Main Tank	97.558 [mg/s]
Out of Aux. Tank	2.045 [mg/s]
Out of external He- dewar for CTA-shroud cooling	150.000 [mg/s]

5.5 CTA Cold Plate Design 1

CTA Cold Plate Design 1 means: Mirror black (emissivity = 0.9)

The input parameters are compiled in Table 5-17 and a brief temperature results summary is given in Table 5-18. The complete ESATAN-output-file listing is appended for the 10 mg/s case. The respective node numbers and labels are referenced in the thermal design and thermal-mathematical model descriptions in § 4

Input parameter	
Main Tank temperature	4.2 K
EQM-aux. Tank temperature	1.7 K
External Hel dewar temp. for CTA-cold plate cooling	4.2 K
Main Tank heater power	2000 mW
EQM-auxiliary tank heater power	14 mW
CTA-cold plate He-mass flow rate	0 to 50 mg/s

Table 5-17: Input parameters

Thermal node	Description	0 mg/s	1 mg/s	10 mg/s	50 mg/s
900	Vacuum tight plate	292 K	292 K	291 K	289 K
1100	Radiation Shield 2	239 K	186 K	23 K	10 K
1200	Radiation Shield 1	173 K	104 K	6 K	5 K
1500	Mirror (black)	126 K	52 K	5 K	4.7 K
371 - 381	HOB	20 K	11.5 K	11 K	11 K

Table 5-18: Temperature results summary, CTA Cold Plate Design 1

EUROPEAN SPACE AGENCY THERMAL ANALYSIS NETWORK
 (VERSION 8.5.0) PAGE 1
 7 MAY 2002
 EQM6

14:27:58

```
#####
# EQM6: CTA Cold Plate
# CTA-ventline-cooling switched on
#
# Main Tank heater power: 2000 mW
# Aux. Tank heater power: 14 mW
# CTA-shroud mass flow rate: 10 mg/s
#
#####
```

+EQM6

NODE	LABEL	T	QI	QR	C
9999	AMBIENT	293.000	0.00000	0.00000	0.000
1	MAIN TANK	4.200	0.00000	2.00000	0.000
2	AUX TANK	1.700	0.00000	0.01400	0.000
5	Ti-head lo 5	11.288	0.00000	0.00000	71.093
6	belt fitting lo 6	10.679	0.00000	0.00000	63.263
7	strut tank end lo 7	4.359	0.00000	0.00000	21.851
8	Ti-head up 8	11.044	0.00000	0.00000	69.021
9	belt fitting up 9	10.433	0.00000	0.00000	61.239
10	strut tank end up 10	4.349	0.00000	0.00000	21.798
12	HS 1 BULK 12	10.597	0.00000	0.00000	14.055
13	HS 2 BULK 13	22.974	0.00000	0.00000	140.014
14	HS 3 BULK +Z 14	119.555	0.00000	0.00000	2767.948
15	HS 3 BULK -Z 15	119.521	0.00000	0.00000	2767.306
22	HS 1 CYL 22	10.523	0.00000	0.00000	44.747
23	HS 2 CYL 23	21.961	0.00000	0.00000	330.301
24	HS 3 CYL +Z 24	97.603	0.00000	0.00000	6858.580
25	HS 3 CYL -Z 25	97.501	0.00000	0.00000	6849.281
32	HS 1 CONE 32	15.538	0.00000	0.00000	91.795
33	HS 2 CONE 33	37.974	0.00000	0.00000	1507.540
34	HS 3 CONE +Z 34	142.245	0.00000	0.00000	7724.449
35	HS 3 CONE -Z 35	142.451	0.00000	0.00000	7724.449
42	HS 1 HIFI Baf. int.	25.641	0.00000	0.00000	2.928
52	HS 1 HIFI Baf. ext.	32.963	0.00000	0.00000	2.671
53	HS 2 HIFI Baf.	57.545	0.00000	0.00000	10.611
54	HS 3 HIFI Baf.	175.170	0.00000	0.00000	45.556
62	HS 1 Tele BAF	15.565	0.00000	0.00000	0.346
63	HS 2 Tele BAF	38.160	0.00000	0.00000	5.535
64	HS 3 Tele BAF	142.152	0.00000	0.00000	81.063
101	MLI MAIN TANK LO 101	5.168	0.00000	0.00000	15.688
105	MLI MAIN TANK CY 105	4.735	0.00000	0.00000	43.340
106	MLI MAIN TANK UP 106	37.055	0.00000	0.00000	112.492
112	MLI HS 1 BULK 112	20.320	0.00000	0.00000	39.941
113	MLI HS 2 BULK 113	115.109	0.00000	0.00000	381.970
114	MLI HS 3 BULK +Z 114	287.451	0.00000	0.00000	706.439
115	MLI HS 3 BULK -Z 115	287.428	0.00000	0.00000	706.380
122	MLI HS 1 CYL 122	19.254	0.00000	0.00000	122.992
123	MLI HS 2 CYL 123	93.733	0.00000	0.00000	969.200
124	MLI HS 3 CYL +Z 124	286.648	0.00000	0.00000	2100.791

125	MLI HS 3 CYL -Z	125	285.591	0.00000	0.00000	2093.041
132	MLI HS 1 CONE	132	51.483	0.00000	0.00000	249.737
133	MLI HS 2 CONE	133	137.735	0.00000	0.00000	1125.106
134	MLI HS 3 CONE +Z	134	287.131	0.00000	0.00000	1701.105
135	MLI HS 3 CONE -Z	135	287.113	0.00000	0.00000	1700.994
440	filling tube	440	271.450	0.00000	0.00000	0.000
441	filling tube	441	252.163	0.00000	0.00000	0.000
442	filling tube	442	245.464	0.00000	0.00000	0.000
443	filling tube	443	242.406	0.00000	0.00000	0.000
447	empty tube	447	15.525	0.00000	0.00000	0.000
452	empty tube	452	10.862	0.00000	0.00000	0.000
502	line baf to HS1	502	4.201	0.00000	0.00000	0.000
642	MLI filling tube	642	120.412	0.00000	0.00000	0.766
643	MLI filling tube	643	118.994	0.00000	0.00000	0.743
647	MLI filling tube	647	25.806	0.00000	0.00000	1.244
652	MLI filling tube	652	23.540	0.00000	0.00000	0.459
1000	HS 1 SUSP BOLT	1000	19.625	0.00000	0.00000	48.203
2000	HS 2 SUSP BOLT	2000	67.886	0.00000	0.00000	229.721
3000	HS 3 SUSP BOLT	3000	189.807	0.00000	0.00000	737.487
4001	CVV lower bulk	4001	292.764	0.00000	0.00000	4399.463
4002	CVV lower bulk	4002	292.771	0.00000	0.00000	4399.490
4003	CVV lower bulk	4003	292.771	0.00000	0.00000	4399.491
4004	CVV lower bulk	4004	292.764	0.00000	0.00000	4399.462
4005	CVV lower bulk	4005	292.750	0.00000	0.00000	4399.407
4006	CVV lower bulk	4006	292.749	0.00000	0.00000	4399.403
4007	CVV lower bulk	4007	292.758	0.00000	0.00000	4399.441
4008	CVV lower bulk	4008	292.760	0.00000	0.00000	4399.449
4011	CVV lower bulk	4011	292.707	0.00000	0.00000	1668.975
4012	CVV lower bulk	4012	292.740	0.00000	0.00000	1669.025
4013	CVV lower bulk	4013	292.741	0.00000	0.00000	1669.027
4014	CVV lower bulk	4014	292.717	0.00000	0.00000	1668.991
4015	CVV lower bulk	4015	292.654	0.00000	0.00000	1668.893
4016	CVV lower bulk	4016	292.654	0.00000	0.00000	1668.893
4017	CVV lower bulk	4017	292.704	0.00000	0.00000	1668.971
4018	CVV lower bulk	4018	292.700	0.00000	0.00000	1668.964
4031	CVV cyl lower	4031	292.552	0.00000	0.00000	13706.669
4032	CVV cyl lower	4032	292.660	0.00000	0.00000	13708.029
4033	CVV cyl lower	4033	292.663	0.00000	0.00000	13708.065
4034	CVV cyl lower	4034	292.598	0.00000	0.00000	13707.254
4035	CVV cyl lower	4035	292.392	0.00000	0.00000	13704.644
4036	CVV cyl lower	4036	292.396	0.00000	0.00000	13704.703
4037	CVV cyl lower	4037	292.568	0.00000	0.00000	13706.868
4038	CVV cyl lower	4038	292.536	0.00000	0.00000	13706.470
4041	CVV cyl upper	4041	292.688	0.00000	0.00000	19514.499
4042	CVV cyl upper	4042	292.693	0.00000	0.00000	19514.587
4043	CVV cyl upper	4043	292.627	0.00000	0.00000	19513.406
4044	CVV cyl upper	4044	292.210	0.00000	0.00000	19505.918
4045	CVV cyl upper	4045	289.657	0.00000	0.00000	19460.027
4046	CVV cyl upper	4046	289.651	0.00000	0.00000	19459.931
4047	CVV cyl upper	4047	292.181	0.00000	0.00000	19505.386
4048	CVV cyl upper	4048	292.597	0.00000	0.00000	19512.871
4051	CVV upper bulk	4051	292.614	0.00000	0.00000	19049.217
4052	CVV upper bulk	4052	292.528	0.00000	0.00000	19047.699
4053	CVV upper bulk	4053	292.520	0.00000	0.00000	19047.557
4054	CVV upper bulk	4054	292.573	0.00000	0.00000	19048.502
4055	CVV upper bulk	4055	292.493	0.00000	0.00000	19047.100
4056	CVV upper bulk	4056	292.448	0.00000	0.00000	19046.306
4057	CVV upper bulk	4057	292.583	0.00000	0.00000	19048.663
4058	CVV upper bulk	4058	292.620	0.00000	0.00000	19049.321
4061	CVV/CTA flange	4061	291.279	0.00000	0.00000	322.774
4062	CVV/CTA flange	4062	291.256	0.00000	0.00000	322.767
4063	CVV/CTA flange	4063	291.252	0.00000	0.00000	322.766
4064	CVV/CTA flange	4064	291.262	0.00000	0.00000	322.769

4065	CVV/CTA flange	4065	291.241	0.00000	0.00000	322.763
4066	CVV/CTA flange	4066	291.232	0.00000	0.00000	322.760
4067	CVV/CTA flange	4067	291.267	0.00000	0.00000	322.771
4068	CVV/CTA flange	4068	291.282	0.00000	0.00000	322.775
4071	CVV flange disc	4071	290.808	0.00000	0.00000	1526.232
4072	CVV flange disc	4072	290.801	0.00000	0.00000	1526.223
4073	CVV flange disc	4073	290.799	0.00000	0.00000	1526.220
4074	CVV flange disc	4074	290.800	0.00000	0.00000	1526.221
4075	CVV flange disc	4075	290.794	0.00000	0.00000	1526.213
4076	CVV flange disc	4076	290.793	0.00000	0.00000	1526.211
4077	CVV flange disc	4077	290.803	0.00000	0.00000	1526.225
4078	CVV flange disc	4078	290.809	0.00000	0.00000	1526.233
4090	CVV Lo window		289.838	0.00000	0.00000	15.602
4631	SUSP TI lo	4631	282.780	0.00000	0.00000	84.266
4632	SUSP TI lo	4632	282.879	0.00000	0.00000	84.277
4633	SUSP TI lo	4633	282.882	0.00000	0.00000	84.277
4634	SUSP TI lo	4634	282.823	0.00000	0.00000	84.271
4635	SUSP TI lo	4635	282.632	0.00000	0.00000	84.250
4636	SUSP TI lo	4636	282.637	0.00000	0.00000	84.251
4637	SUSP TI lo	4637	282.794	0.00000	0.00000	84.268
4638	SUSP TI lo	4638	282.765	0.00000	0.00000	84.265
4641	SUSP TI up	4641	282.905	0.00000	0.00000	84.279
4642	SUSP TI up	4642	282.910	0.00000	0.00000	84.280
4643	SUSP TI up	4643	282.849	0.00000	0.00000	84.273
4644	SUSP TI up	4644	282.466	0.00000	0.00000	84.233
4645	SUSP TI up	4645	280.117	0.00000	0.00000	83.982
4646	SUSP TI up	4646	280.112	0.00000	0.00000	83.982
4647	SUSP TI up	4647	282.438	0.00000	0.00000	84.230
4648	SUSP TI up	4648	282.822	0.00000	0.00000	84.271
4731	CABLE PLUG	4731	281.498	0.00073	0.00000	93.529
4732	CABLE PLUG	4732	291.587	0.00000	0.00000	97.057
4733	CABLE PLUG	4733	291.590	0.00000	0.00000	97.058
4734	CABLE PLUG	4734	291.526	0.00000	0.00000	97.036
4735	CABLE PLUG	4735	291.321	0.00000	0.00000	96.964
4736	CABLE PLUG	4736	292.396	0.00000	0.00000	97.340
4737	CABLE PLUG	4737	292.568	0.00000	0.00000	97.400
4738	CABLE PLUG	4738	283.622	0.00010	0.00000	94.271
6051	X2 SI Harness	51	245.203	0.00073	0.00000	0.000
6052	X2 SI Harness	52	205.933	0.00073	0.00000	0.000
6053	X2 SI Harness	53	162.824	0.00073	0.00000	0.000
6054	X2 SI Harness	54	113.891	0.00073	0.00000	0.000
6055	X2 SI at HS1	55	50.555	0.00250	0.00000	0.000
6056	X3 SI Harness	56	45.785	0.00250	0.00000	0.000
6057	X3 SI Harness	57	39.274	0.00250	0.00000	0.000
6058	X3 SI Harness	58	29.874	0.00250	0.00000	0.000
6061	X2 JF Harness	61	246.338	0.00010	0.00000	0.000
6062	X2 JF Harness	62	205.932	0.00010	0.00000	0.000
6063	X2 JF Harness	63	161.455	0.00010	0.00000	0.000
6064	X2 JF Harness	64	110.710	0.00010	0.00000	0.000
6065	X2 JF at HS1	65	42.547	0.00024	0.00000	0.000
6066	X3 JF Harness	66	38.113	0.00024	0.00000	0.000
6067	X3 JF Harness	67	32.991	0.00024	0.00000	0.000
6068	X3 JF Harness	68	26.769	0.00024	0.00000	0.000
9999	AMBIENT		293.000	0.00000	0.00000	0.000

=====

+EQM6:CRYO:V

NODE		LABEL	T	QI	QR	C
201	OSS-TUBE	201	4.200	0.00000	0.00000	0.000
202	BAFFLE LO	202	4.200	0.00000	0.00000	0.000
203	BAFFLE UP	203	4.200	0.00000	0.00000	0.000
204	1ST HS	204	10.523	0.00000	0.00000	0.000
205	2ND HS	205	21.961	0.00000	0.00000	0.000
206	3RD HS +z	206	97.603	0.00000	0.00000	0.000
207	3RD HS -z	207	97.501	0.00000	0.00000	0.000
210	VENT VESSEL	210	209.894	0.00000	0.00000	0.000
212	BAFFLE - 1ST HS	212	4.201	0.00000	0.00000	0.000
251	TANK HE-OUT	251	4.200	0.00000	0.00000	0.000
252	OSS HE-OUT	252	4.200	0.00000	0.00000	0.000
253	BAFFLE LO HE-OUT	253	4.200	0.00000	0.00000	0.000
254	BAFFLE UP HE-OUT	254	4.200	0.00000	0.00000	0.000
255	1ST HS HE-OUT	255	10.523	0.00000	0.00000	0.000
256	2ND HS HE-OUT	256	21.942	0.00000	0.00000	0.000
257	3RD HS HE-OUT	257	97.552	0.00000	0.00000	0.000
260	VESSEL HE-OUT	260	209.894	0.00000	0.00000	0.000
262	BAF - HS1 HE-OUT	262	4.200	0.00000	0.00000	0.000
296	HEATER WALL	296	293.000	0.00000	0.00000	0.000
297	HEATER HE-OUT	297	209.894	0.00000	0.00000	0.000

=====

+EQM6:CRYO:PLM

NODE	LABEL	T	QI	QR	C
310	Instr. Shield Cyl.	11.293	0.00000	0.00000	7.634
311	Instr. Shield Top	11.305	0.00000	0.00000	9.884
315	Instr. Shield Baffle	11.321	0.00000	0.00000	0.638
320	Vline wall Tank-PACS	1.753	0.00000	0.00000	0.007
321	Vline wall PACS I/F 1	2.376	0.00000	0.00000	0.000
322	Vline wall PACS I/F 1	2.618	0.00000	0.00000	0.000
323	Vline wall PACS I/F 1	2.456	0.00000	0.00000	0.000
324	Vline wall PACSI/F1/2	2.286	0.00000	0.00000	0.003
325	Vline wall PACSI/F1/2	2.314	0.00000	0.00000	0.013
326	Vline wall PACS I/F 2	2.681	0.00000	0.00000	0.000
327	Vline wall PACS I/F 2	2.831	0.00000	0.00000	0.000
328	Vline wall PACS I/F 2	2.741	0.00000	0.00000	0.000
329	Vline wall PACSI/F2/3	2.649	0.00000	0.00000	0.005
330	Vline wall PACSI/F2/3	2.714	0.00000	0.00000	0.002
331	Vline wall PACS I/F 3	2.847	0.00000	0.00000	0.000
332	Vline wall PACS I/F 3	2.952	0.00000	0.00000	0.000
333	Vline wall PACS I/F 3	2.904	0.00000	0.00000	0.000
334	Vline wall PACS-SPIRE	2.860	0.00000	0.00000	0.005
335	Vline wall PACS-SPIRE	2.882	0.00000	0.00000	0.007
336	Vline wall PACS-SPIRE	3.035	0.00000	0.00000	0.008
337	Vline wall SPIRE	3.951	0.00000	0.00000	0.000
338	Vline wall SPIRE	4.483	0.00000	0.00000	0.000
339	Vline wall SPIRE	4.232	0.00000	0.00000	0.000
340	Vline wall SPIRE-HIFI	4.022	0.00000	0.00000	0.011
341	Vline wall SPIRE-HIFI	4.035	0.00000	0.00000	0.014
342	Vline wall SPIRE-HIFI	4.136	0.00000	0.00000	0.017
343	Vline wall HIFI	5.032	0.00000	0.00000	0.000
344	Vline wall HIFI	5.559	0.00000	0.00000	0.000
345	Vline wall HIFI	5.851	0.00000	0.00000	0.000
346	Vline Lev.2 OB	9.807	0.00000	0.00000	0.065
347	Vline Lev.2 OB	10.884	0.00000	0.00000	0.189
348	Vline Lev.2 OB	11.004	0.00000	0.00000	0.076
349	Vline Lev.2 OB	11.077	0.00000	0.00000	0.122
350	Vline Lev.2 OB	11.106	0.00000	0.00000	0.072
351	Vline Lev.2 OB	11.112	0.00000	0.00000	0.212
352	Vline Lev.2 OB	11.137	0.00000	0.00000	0.109
371	Opt. Bench +Z	11.023	0.00000	0.00000	7.230
372	Opt. Bench +Z -Y	10.955	0.00000	0.00000	6.561
373	Opt. Bench +Z mid	11.036	0.00000	0.00000	17.009
374	Opt. Bench +Z +Y	11.053	0.00000	0.00000	2.756
375	Opt. Bench -Y	11.106	0.00000	0.00000	12.610
376	Opt. Bench centre	11.088	0.00000	0.00000	30.354
377	Opt. Bench +Y	11.093	0.00000	0.00000	6.684
378	Opt. Bench -Z -Y	11.140	0.00000	0.00000	6.894
379	Opt. Bench -Z mid	11.116	0.00000	0.00000	17.374
380	Opt. Bench -Z +Y	11.118	0.00000	0.00000	2.804
381	Opt. Bench -Z	11.113	0.00000	0.00000	7.406
390	I.Shld HIFI Baf. ext.	11.370	0.00000	0.00000	0.300
391	I.Shld HIFI Baf. int.	11.298	0.00000	0.00000	0.105
411	MLI on OB-Shield side	13.793	0.00000	0.00000	31.382
412	MLI on OB-Shield top	13.797	0.00000	0.00000	40.525
710	PACS-Top Optic	3.133	0.00000	0.00000	1.867
720	PACS-Spectrometer	3.131	0.00003	0.00000	2.110
725	PACS-Collimator	3.128	0.00000	0.00000	2.134
730	PACS-Photometer Optic	3.127	0.00000	0.00000	1.289
735	PACS-Internal	3.132	0.00000	0.00000	1.790
740	PACS-Lump	3.132	0.00000	0.00000	0.000
750	PACS-Chopper	3.136	0.00040	0.00000	0.113

755	PACS-Grating Assy	3.135	0.00100	0.00000	0.769
760	PACS-Red Detector	1.704	0.00000	0.00000	0.230
761	PACS-Red Detect. CRE	3.143	0.00030	0.00000	0.000
765	PACS-Blue Detector	1.723	0.00013	0.00000	0.233
766	PACS-Blue Detect. CRE	3.143	0.00030	0.00000	0.000
770	PACS-Filter Wh. Blue	3.131	0.00004	0.00000	0.131
771	PACS-Filter Wh. Photo	3.127	0.00004	0.00000	0.131
775	PACS-Calib. Source 1	3.134	0.00032	0.00000	0.000
776	PACS-Calib. Source 2	3.137	0.00032	0.00000	0.000
780	PACS-Photometer Housi	3.129	0.00000	0.00000	0.989
781	PACS-Photometer CooPu	1.781	0.00220	0.00000	0.147
791	PACS-STST-Strut 1,1	8.951	0.00000	0.00000	0.318
792	PACS-STST-Strut 4,1	8.947	0.00000	0.00000	0.495
793	PACS-STST-Strut 5,1	8.951	0.00000	0.00000	0.247
794	PACS-Kevlar-Strut Red 1	2.597	0.00000	0.00000	0.000
795	PACS-Kevlar-Strut Blue 1	2.601	0.00000	0.00000	0.000
796	PACS-HarnessRed Det.Intl	2.533	0.00000	0.00000	0.000
797	PACS-HarnessBlueDet.Intl	2.539	0.00000	0.00000	0.000
798	PACS-HarnessBlue1.7->4,1	2.524	0.00000	0.00000	0.000
801	SPIRE PM JFET ENCL	11.147	0.01026	0.00000	10.520
802	SPIRE SM JFET ENCL	11.121	0.00282	0.00000	3.410
803	SPIRE Optical Bench	5.094	0.00000	0.00000	9.567
804	SPIRE RF Filter Box	5.099	0.00428	0.00000	0.469
805	SPIRE Beam St. Mech	5.095	0.00100	0.00000	0.351
806	SPIRE SMECm	5.095	0.00048	0.00000	0.415
807	SPIRE PM calibrator	5.095	0.00002	0.00000	0.000
808	SPIRE SM calibrator	9.361	0.00040	0.00000	0.000
809	SPIRE Shutter	5.094	0.00000	0.00000	0.000
810	SPIRE PM Detector en	1.795	0.00000	0.00000	0.451
811	SPIRE SM Detector en	1.772	0.00000	0.00000	0.269
812	SPIRE PM Detectors	1.741	0.00000	0.00000	0.398
813	SPIRE SM detector	1.741	0.00000	0.00000	0.252
816	SPIRE Cooler Pump	1.887	0.00183	0.00000	0.000
817	SPIRE Cooler shunt	1.725	0.00000	0.00000	0.000
818	SPIRE Cooler evap	1.741	0.00000	0.00000	0.000
819	SPIRE Cooler pump HS	1.773	0.00008	0.00000	0.000
820	SPIRE Cooler evap HS	1.724	0.00000	0.00000	0.000
900	HIFI 2K level	1.853	0.00014	0.00000	0.000
905	HIFI Harness 1 int.point	5.942	0.00036	0.00000	0.000
910	HIFI FPU Structure	11.120	0.01602	0.00000	99.127
912	HIFI L0 boundary node	1.847	0.00000	0.00000	0.000
913	HIFI L1 boundary node	5.817	0.00000	0.00000	0.000
914	HIFI Harness 2a int.poin	12.522	0.00036	0.00000	0.000
915	HIFI Harness 2b int.poin	8.862	0.00000	0.00000	0.000
920	HIFI Internal Assy.	5.821	0.00000	0.00000	0.023
5000	GHe tank outlet	1.700	0.00000	0.00000	0.000
5010	GHe PACS I/F 1 in	1.750	0.00000	0.00000	0.000
5011	GHe PACS I/F 1	1.955	0.00000	0.00000	0.000
5012	GHe PACS I/F 1	2.086	0.00000	0.00000	0.000
5013	GHe PACS I/F 1 out	2.214	0.00000	0.00000	0.000
5014	GHe PACS I/F 1/2	2.267	0.00000	0.00000	0.000
5020	GHe PACS I/F 2 in	2.311	0.00000	0.00000	0.000
5021	GHe PACS I/F 2	2.447	0.00000	0.00000	0.000
5022	GHe PACS I/F 2	2.530	0.00000	0.00000	0.000
5023	GHe PACS I/F 2 out	2.610	0.00000	0.00000	0.000
5024	GHe PACS I/F 2/3	2.645	0.00000	0.00000	0.000
5030	GHe PACS I/F 3 in	2.690	0.00000	0.00000	0.000
5031	GHe PACS I/F 3	2.751	0.00000	0.00000	0.000
5032	GHe PACS I/F 3	2.797	0.00000	0.00000	0.000
5033	GHe PACS I/F 3 out	2.839	0.00000	0.00000	0.000
5034	GHe PACS-SPIRE	2.858	0.00000	0.00000	0.000
5035	GHe PACS-SPIRE	2.881	0.00000	0.00000	0.000
5040	GHe SPIRE I/F in	3.027	0.00000	0.00000	0.000

5041	GHe SPIRE I/F	3.450	0.00000	0.00000	0.000
5042	GHe SPIRE I/F	3.740	0.00000	0.00000	0.000
5043	GHe SPIRE I/F out	3.977	0.00000	0.00000	0.000
5044	GHe SPIRE-HIFI	4.020	0.00000	0.00000	0.000
5045	GHe SPIRE-HIFI	4.035	0.00000	0.00000	0.000
5050	GHe HIFI I/F in	4.131	0.00000	0.00000	0.000
5051	GHe HIFI I/F	4.595	0.00000	0.00000	0.000
5052	GHe HIFI I/F	4.901	0.00000	0.00000	0.000
5053	GHe HIFI I/F out	5.429	0.00000	0.00000	0.000
5054	GHe Lev.2 OB	9.589	0.00000	0.00000	0.000
5055	GHe Lev.2 OB	10.819	0.00000	0.00000	0.000
5056	GHe Lev.2 OB	10.995	0.00000	0.00000	0.000
5057	GHe Lev.2 OB	11.073	0.00000	0.00000	0.000
5058	GHe Lev.2 OB	11.104	0.00000	0.00000	0.000
5059	GHe Lev.2 OB	11.112	0.00000	0.00000	0.000
5060	GHe Lev.2 OB	11.136	0.00000	0.00000	0.000
6059	X3 SI Harness 59	11.972	0.00406	0.00000	0.000
6069	X3 JF Harness 69	18.422	0.00040	0.00000	0.000
9999	Ambient Air	293.000	0.00000	0.00000	0.000

+EQM6:CTCE

NODE	LABEL	T	QI	QR	C
900	Vacuumtight Plate	290.453	0.00000	0.00000	6968.004
1100	Radiation shield 2	23.199	0.00000	0.00000	6.448
1200	Radiation shield 1	6.381	0.00000	0.00000	0.243
1310	RS1 cyl. MLI	8.670	0.00000	0.00000	0.000
1320	RS1 disc MLI	8.670	0.00000	0.00000	0.000
1410	RS2 cyl. MLI	274.852	0.00000	0.00000	0.000
1420	RS2 disc MLI	277.418	0.00000	0.00000	0.000
1500	Mirror&Support	5.268	0.00000	0.00000	1.176
2000	CTA-Shroud Dewar	4.200	0.00000	0.00000	0.000
2001	GHe Shroud 1500 out	5.095	0.00000	0.00000	0.000
2002	GHe Shroud 1200 out	6.230	0.00000	0.00000	0.000
2003	GHe Shroud 1100 out	22.355	0.00000	0.00000	0.000
2004	GHe Shroud 900 out	198.652	0.00000	0.00000	0.000
9999	AMBIENT	293.000	0.00000	0.00000	0.000

Heat Balance for PAYLOAD incl. Instrument Shield MLI

=====		
Level 0: from Aux. Tank into instruments	-15.555	[mW]
Level 2: from spatial framework into OB	-0.696	[mW]
Level 1/2: from Aux. Tank into OB via ventline wall	-0.061	[mW]
Level 2: from HS1 into OB via ventline wall	0.164	[mW]
Level 2: via harness into OB	27.226	[mW]
via radiation from HS1 upper bulkhead onto Instrument MLI	0.244	[mW]
via radiation from Cryostat cavity onto OB lower side	5.132	[mW]
via radiation from HS1-baffle into payload	0.007	[mW]
via radiation from HS2-baffle into payload	0.023	[mW]
via radiation from HS3-baffle into payload	1.507	[mW]
via radiation from CTA mirror into payload	-0.017	[mW]
via radiation from CVV-LOU-Window onto HIFI-Baffle	19.928	[mW]
via radiation from CVV-LOU-Window onto HIFI-FPU	14.494	[mW]
Vent line cooling power (out of payload)	102.289	[mW]
Transferred by convection from PL-ventline on helium	102.318	[mW]
total dissipation of PACS	5.070	[mW]
total dissipation of SPIRE	21.167	[mW]
total dissipation of HIFI	16.867	[mW]
Harness dissipation on OB	4.462	[mW]
Payload Heat Imbalance (shall be 0)	-2.308	[mW]

Heat Balance for Main Tank Ventline

=====		
conducted and radiated into ventline attached to HS1	3203.507	[mW]
conducted and radiated into ventline attached to HS2	5785.348	[mW]
conducted and radiated into ventline attached to HS3 +Z	19166.795	[mW]
conducted and radiated into ventline attached to HS3 -Z	19140.972	[mW]
conducted into ventline walls from CVV	56918.739	[mW]
conducted and radiated into line baf to HS 1	0.152	[mW]
Main Tank Ventline cooling power (out of ventline)	104215.609	[mW]
Via convection into ventline walls	-104225.499	[mW]
Main Tank Ventline Imbalance (shall be 0)	-0.096	[mW]

Heat Balance for CTA-Cold Plate

=====		
Convective heat transfer onto CTA vacuumtight plate	1715.116	[mW]
Conducted from CVV into CTA vacuum tight plate	8341.075	[mW]
Radiated from Payload onto CTA mirror	0.017	[mW]
Radiated from HS-baffles onto CTA-Radiation Shield 1	48.658	[mW]
Cooling power of CTA-heatshields	10104.867	[mW]
CTCE Imbalance (shall be 0)	-0.001	[mW]

Heat Balance for whole Cryostat including Payload, Ventlines and CTCE

=====		
Convective heat transfer onto external walls	114255.055	[mW]
total heat transferred on gaseous helium	114422.765	[mW]
evaporation power in main and aux. tank	2087.178	[mW]
Total instrument power dissipation	43.104	[mW]
total main & auxiliary tank heater power	2014.000	[mW]
heater power of CVV lower bulkhead HTR	0.000	[mW]
total harness dissipation within system	19.601	[mW]
Cooling power of CTCE-shrouds	10104.867	[mW]
Cryostat total imbalance (shall be 0)	-178.183	[mW]

Heat Balance for Main Tank

=====		
Main tank dissipation + heater power	2000.000	[mW]
radiated from aux. tank	0.000	[mW]
conducted from spatial framework	29.525	[mW]
transferred through MLI	9.744	[mW]
conducted from rest	0.290	[mW]
radiated from spatial framework and HSs	0.077	[mW]
conducted from main tank ventline wall	0.000	[mW]
radiated from payload	0.000	[mW]
total heat into main tank	2039.636	[mW]

Heat Balance for Auxiliary Tank

=====

Aux. tank dissipation + heater power	14.000	[mW]
heat from Ti-heads via mech. I/F	2.214	[mW]
radiated from Main tank	0.000	[mW]
radiated from spatial framework and HSs	0.015	[mW]
conducted from payload L0	15.555	[mW]
conducted from payload L2	0.061	[mW]
radiated from payload	0.011	[mW]
conducted from filling tube	0.007	[mW]
radiated from MLI filling tube	15.678	[mW]
total heat into Aux. tank	47.543	[mW]

Heat flows into Tanks

=====

Into Main Tank	2039.636	[mW]
Into Aux. Tank	47.543	[mW]

Helium evaporation mass flow rates

=====

Out of Main Tank	97.497	[mg/s]
Out of Aux. Tank	2.086	[mg/s]
Out of external He- dewar for CTA-shroud cooling	10.000	[mg/s]

5.6 CTA Cold Plate Design 2

CTA Cold Plate Design 2 means: Mirror goldized (emissivity = 0.05)

The input parameters are compiled in Table 5-19 and a brief temperature results summary is given in Table 5-20. The complete ESATAN-output-file listing is appended for the 10 mg/s case. The respective node numbers and labels are referenced in the thermal design and thermal-mathematical model descriptions in § 4

<i>Input parameter</i>	
<i>Main Tank temperature</i>	4.2 K
<i>EQM-aux. Tank temperature</i>	1.7 K
<i>External Hel dewar temp. for CTA-cold plate cooling</i>	4.2 K
<i>Main Tank heater power</i>	2000 mW
<i>EQM-auxiliary tank heater power</i>	14 mW
<i>CTA-cold plate He-mass flow rate</i>	0 to 50 mg/s

Table 5-19: Input parameters

Thermal node	Description	0 mg/s	1 mg/s	10 mg/s	50 mg/s
900	Vacuum tight plate	292 K	292 K	291 K	289 K
1100	Radiation Shield 2	250 K	187 K	23 K	10 K
1200	Radiation Shield 1	200 K	106 K	6 K	5 K
1500	Mirror (goldized)	193 K	54 K	5 K	4.7 K
371 - 381	HOB	15 K	11 K	11 K	11 K

Table 5-20: Temperature results summary, CTA Cold Plate Design 2

EUROPEAN SPACE AGENCY THERMAL ANALYSIS NETWORK

(VERSION 8.5.0)

PAGE 1

8 MAY 2002

11:17:27

EQM7

```
#####
# EQM0: CTA Cold Plate, goldized Mirror (emissivity = 0.05)
# CTA-ventline-cooling switched on
#
# Main Tank heater power: 2000 mW
# Aux. Tank heater power: 14 mW
# CTA-shroud mass flow rate: 10 mg/s
#
#####
```

NODE	LABEL	T	QI	QR	C
9999	AMBIENT	293.000	0.00000	0.00000	0.000
1	MAIN TANK	4.200	0.00000	2.00000	0.000
2	AUX TANK	1.700	0.00000	0.01400	0.000
5	Ti-head lo 5	11.288	0.00000	0.00000	71.093
6	belt fitting lo 6	10.679	0.00000	0.00000	63.263
7	strut tank end lo 7	4.359	0.00000	0.00000	21.851
8	Ti-head up 8	11.044	0.00000	0.00000	69.026
9	belt fitting up 9	10.434	0.00000	0.00000	61.244
10	strut tank end up 10	4.349	0.00000	0.00000	21.798
12	HS 1 BULK 12	10.597	0.00000	0.00000	14.055
13	HS 2 BULK 13	22.974	0.00000	0.00000	140.014
14	HS 3 BULK +Z 14	119.554	0.00000	0.00000	2767.946
15	HS 3 BULK -Z 15	119.521	0.00000	0.00000	2767.305
22	HS 1 CYL 22	10.523	0.00000	0.00000	44.747
23	HS 2 CYL 23	21.961	0.00000	0.00000	330.299
24	HS 3 CYL +Z 24	97.602	0.00000	0.00000	6858.571
25	HS 3 CYL -Z 25	97.501	0.00000	0.00000	6849.271
32	HS 1 CONE 32	15.538	0.00000	0.00000	91.795
33	HS 2 CONE 33	37.974	0.00000	0.00000	1507.537
34	HS 3 CONE +Z 34	142.245	0.00000	0.00000	7724.445
35	HS 3 CONE -Z 35	142.451	0.00000	0.00000	7724.445
42	HS 1 HIFI Baf. int.	25.641	0.00000	0.00000	2.928
52	HS 1 HIFI Baf. ext.	32.963	0.00000	0.00000	2.671
53	HS 2 HIFI Baf.	57.545	0.00000	0.00000	10.611
54	HS 3 HIFI Baf.	175.170	0.00000	0.00000	45.556
62	HS 1 Tele BAF	15.565	0.00000	0.00000	0.346
63	HS 2 Tele BAF	38.160	0.00000	0.00000	5.535
64	HS 3 Tele BAF	142.152	0.00000	0.00000	81.063
101	MLI MAIN TANK LO 101	5.168	0.00000	0.00000	15.688
105	MLI MAIN TANK CY 105	4.735	0.00000	0.00000	43.340
106	MLI MAIN TANK UP 106	37.055	0.00000	0.00000	112.492
112	MLI HS 1 BULK 112	20.320	0.00000	0.00000	39.941
113	MLI HS 2 BULK 113	115.109	0.00000	0.00000	381.970
114	MLI HS 3 BULK +Z 114	287.451	0.00000	0.00000	706.439
115	MLI HS 3 BULK -Z 115	287.428	0.00000	0.00000	706.380
122	MLI HS 1 CYL 122	19.254	0.00000	0.00000	122.992
123	MLI HS 2 CYL 123	93.733	0.00000	0.00000	969.199
124	MLI HS 3 CYL +Z 124	286.648	0.00000	0.00000	2100.791
125	MLI HS 3 CYL -Z 125	285.591	0.00000	0.00000	2093.041
132	MLI HS 1 CONE 132	51.483	0.00000	0.00000	249.737
133	MLI HS 2 CONE 133	137.735	0.00000	0.00000	1125.105
134	MLI HS 3 CONE +Z 134	287.131	0.00000	0.00000	1701.105
135	MLI HS 3 CONE -Z 135	287.113	0.00000	0.00000	1700.994

440	filling tube	440	271.450	0.00000	0.00000	0.000
441	filling tube	441	252.163	0.00000	0.00000	0.000
442	filling tube	442	245.464	0.00000	0.00000	0.000
443	filling tube	443	242.406	0.00000	0.00000	0.000
447	empty tube	447	15.525	0.00000	0.00000	0.000
452	empty tube	452	10.862	0.00000	0.00000	0.000
502	line baf to HS1	502	4.201	0.00000	0.00000	0.000
642	MLI filling tube	642	120.412	0.00000	0.00000	0.766
643	MLI filling tube	643	118.994	0.00000	0.00000	0.743
647	MLI filling tube	647	25.806	0.00000	0.00000	1.244
652	MLI filling tube	652	23.540	0.00000	0.00000	0.459
1000	HS 1 SUSP BOLT	1000	19.625	0.00000	0.00000	48.203
2000	HS 2 SUSP BOLT	2000	67.886	0.00000	0.00000	229.721
3000	HS 3 SUSP BOLT	3000	189.807	0.00000	0.00000	737.487
4001	CVV lower bulk	4001	292.764	0.00000	0.00000	4399.463
4002	CVV lower bulk	4002	292.771	0.00000	0.00000	4399.490
4003	CVV lower bulk	4003	292.771	0.00000	0.00000	4399.491
4004	CVV lower bulk	4004	292.764	0.00000	0.00000	4399.462
4005	CVV lower bulk	4005	292.750	0.00000	0.00000	4399.407
4006	CVV lower bulk	4006	292.749	0.00000	0.00000	4399.403
4007	CVV lower bulk	4007	292.758	0.00000	0.00000	4399.441
4008	CVV lower bulk	4008	292.760	0.00000	0.00000	4399.449
4011	CVV lower bulk	4011	292.707	0.00000	0.00000	1668.975
4012	CVV lower bulk	4012	292.740	0.00000	0.00000	1669.025
4013	CVV lower bulk	4013	292.741	0.00000	0.00000	1669.027
4014	CVV lower bulk	4014	292.717	0.00000	0.00000	1668.991
4015	CVV lower bulk	4015	292.654	0.00000	0.00000	1668.893
4016	CVV lower bulk	4016	292.654	0.00000	0.00000	1668.893
4017	CVV lower bulk	4017	292.704	0.00000	0.00000	1668.971
4018	CVV lower bulk	4018	292.700	0.00000	0.00000	1668.964
4031	CVV cyl lower	4031	292.552	0.00000	0.00000	13706.669
4032	CVV cyl lower	4032	292.660	0.00000	0.00000	13708.029
4033	CVV cyl lower	4033	292.663	0.00000	0.00000	13708.065
4034	CVV cyl lower	4034	292.598	0.00000	0.00000	13707.254
4035	CVV cyl lower	4035	292.392	0.00000	0.00000	13704.644
4036	CVV cyl lower	4036	292.396	0.00000	0.00000	13704.703
4037	CVV cyl lower	4037	292.568	0.00000	0.00000	13706.868
4038	CVV cyl lower	4038	292.536	0.00000	0.00000	13706.470
4041	CVV cyl upper	4041	292.688	0.00000	0.00000	19514.499
4042	CVV cyl upper	4042	292.693	0.00000	0.00000	19514.587
4043	CVV cyl upper	4043	292.627	0.00000	0.00000	19513.406
4044	CVV cyl upper	4044	292.210	0.00000	0.00000	19505.918
4045	CVV cyl upper	4045	289.657	0.00000	0.00000	19460.027
4046	CVV cyl upper	4046	289.651	0.00000	0.00000	19459.930
4047	CVV cyl upper	4047	292.181	0.00000	0.00000	19505.386
4048	CVV cyl upper	4048	292.597	0.00000	0.00000	19512.871
4051	CVV upper bulk	4051	292.614	0.00000	0.00000	19049.217
4052	CVV upper bulk	4052	292.528	0.00000	0.00000	19047.699
4053	CVV upper bulk	4053	292.520	0.00000	0.00000	19047.557
4054	CVV upper bulk	4054	292.573	0.00000	0.00000	19048.502
4055	CVV upper bulk	4055	292.493	0.00000	0.00000	19047.100
4056	CVV upper bulk	4056	292.448	0.00000	0.00000	19046.306
4057	CVV upper bulk	4057	292.583	0.00000	0.00000	19048.663
4058	CVV upper bulk	4058	292.620	0.00000	0.00000	19049.321
4061	CVV/CTA flange	4061	291.279	0.00000	0.00000	322.774
4062	CVV/CTA flange	4062	291.256	0.00000	0.00000	322.767
4063	CVV/CTA flange	4063	291.252	0.00000	0.00000	322.766
4064	CVV/CTA flange	4064	291.262	0.00000	0.00000	322.769
4065	CVV/CTA flange	4065	291.241	0.00000	0.00000	322.763
4066	CVV/CTA flange	4066	291.232	0.00000	0.00000	322.760
4067	CVV/CTA flange	4067	291.267	0.00000	0.00000	322.771
4068	CVV/CTA flange	4068	291.282	0.00000	0.00000	322.775
4071	CVV flange disc	4071	290.808	0.00000	0.00000	1526.232

4072	CVV flange disc	4072	290.801	0.00000	0.00000	1526.223
4073	CVV flange disc	4073	290.799	0.00000	0.00000	1526.220
4074	CVV flange disc	4074	290.800	0.00000	0.00000	1526.221
4075	CVV flange disc	4075	290.794	0.00000	0.00000	1526.213
4076	CVV flange disc	4076	290.793	0.00000	0.00000	1526.211
4077	CVV flange disc	4077	290.803	0.00000	0.00000	1526.225
4078	CVV flange disc	4078	290.809	0.00000	0.00000	1526.233
4090	CVV Lo window		289.838	0.00000	0.00000	15.602
4631	SUSP TI lo	4631	282.780	0.00000	0.00000	84.266
4632	SUSP TI lo	4632	282.879	0.00000	0.00000	84.277
4633	SUSP TI lo	4633	282.882	0.00000	0.00000	84.277
4634	SUSP TI lo	4634	282.823	0.00000	0.00000	84.271
4635	SUSP TI lo	4635	282.632	0.00000	0.00000	84.250
4636	SUSP TI lo	4636	282.637	0.00000	0.00000	84.251
4637	SUSP TI lo	4637	282.794	0.00000	0.00000	84.268
4638	SUSP TI lo	4638	282.765	0.00000	0.00000	84.265
4641	SUSP TI up	4641	282.905	0.00000	0.00000	84.279
4642	SUSP TI up	4642	282.910	0.00000	0.00000	84.280
4643	SUSP TI up	4643	282.849	0.00000	0.00000	84.273
4644	SUSP TI up	4644	282.466	0.00000	0.00000	84.233
4645	SUSP TI up	4645	280.117	0.00000	0.00000	83.982
4646	SUSP TI up	4646	280.112	0.00000	0.00000	83.982
4647	SUSP TI up	4647	282.438	0.00000	0.00000	84.230
4648	SUSP TI up	4648	282.822	0.00000	0.00000	84.271
4731	CABLE PLUG	4731	281.498	0.00073	0.00000	93.529
4732	CABLE PLUG	4732	291.587	0.00000	0.00000	97.057
4733	CABLE PLUG	4733	291.590	0.00000	0.00000	97.058
4734	CABLE PLUG	4734	291.526	0.00000	0.00000	97.036
4735	CABLE PLUG	4735	291.321	0.00000	0.00000	96.964
4736	CABLE PLUG	4736	292.396	0.00000	0.00000	97.340
4737	CABLE PLUG	4737	292.568	0.00000	0.00000	97.400
4738	CABLE PLUG	4738	283.622	0.00010	0.00000	94.271
6051	X2 SI Harness	51	245.203	0.00073	0.00000	0.000
6052	X2 SI Harness	52	205.933	0.00073	0.00000	0.000
6053	X2 SI Harness	53	162.824	0.00073	0.00000	0.000
6054	X2 SI Harness	54	113.891	0.00073	0.00000	0.000
6055	X2 SI at HS1	55	50.555	0.00250	0.00000	0.000
6056	X3 SI Harness	56	45.785	0.00250	0.00000	0.000
6057	X3 SI Harness	57	39.274	0.00250	0.00000	0.000
6058	X3 SI Harness	58	29.875	0.00250	0.00000	0.000
6061	X2 JF Harness	61	246.338	0.00010	0.00000	0.000
6062	X2 JF Harness	62	205.932	0.00010	0.00000	0.000
6063	X2 JF Harness	63	161.455	0.00010	0.00000	0.000
6064	X2 JF Harness	64	110.710	0.00010	0.00000	0.000
6065	X2 JF at HS1	65	42.547	0.00024	0.00000	0.000
6066	X3 JF Harness	66	38.113	0.00024	0.00000	0.000
6067	X3 JF Harness	67	32.991	0.00024	0.00000	0.000
6068	X3 JF Harness	68	26.770	0.00024	0.00000	0.000
9999	AMBIENT		293.000	0.00000	0.00000	0.000

=====

=====

+EQM7:CRYO:V

NODE		LABEL	T	QI	QR	C
201	OSS-TUBE	201	4.200	0.00000	0.00000	0.000
202	BAFFLE LO	202	4.200	0.00000	0.00000	0.000
203	BAFFLE UP	203	4.200	0.00000	0.00000	0.000
204	1ST HS	204	10.523	0.00000	0.00000	0.000
205	2ND HS	205	21.961	0.00000	0.00000	0.000
206	3RD HS +z	206	97.602	0.00000	0.00000	0.000
207	3RD HS -z	207	97.501	0.00000	0.00000	0.000
210	VENT VESSEL	210	209.894	0.00000	0.00000	0.000
212	BAFFLE - 1ST HS	212	4.201	0.00000	0.00000	0.000
251	TANK HE-OUT	251	4.200	0.00000	0.00000	0.000
252	OSS HE-OUT	252	4.200	0.00000	0.00000	0.000
253	BAFFLE LO HE-OUT	253	4.200	0.00000	0.00000	0.000
254	BAFFLE UP HE-OUT	254	4.200	0.00000	0.00000	0.000
255	1ST HS HE-OUT	255	10.523	0.00000	0.00000	0.000
256	2ND HS HE-OUT	256	21.942	0.00000	0.00000	0.000
257	3RD HS HE-OUT	257	97.552	0.00000	0.00000	0.000
260	VESSEL HE-OUT	260	209.894	0.00000	0.00000	0.000
262	BAF - HS1 HE-OUT	262	4.200	0.00000	0.00000	0.000
296	HEATER WALL	296	293.000	0.00000	0.00000	0.000
297	HEATER HE-OUT	297	209.894	0.00000	0.00000	0.000

=====

+EQM7:CRYO:PLM

NODE	LABEL	T	QI	QR	C
310	Instr. Shield Cyl.	11.294	0.00000	0.00000	7.635
311	Instr. Shield Top	11.306	0.00000	0.00000	9.886
315	Instr. Shield Baffle	11.322	0.00000	0.00000	0.638
320	Vline wall Tank-PACS	1.753	0.00000	0.00000	0.007
321	Vline wall PACS I/F 1	2.376	0.00000	0.00000	0.000
322	Vline wall PACS I/F 1	2.618	0.00000	0.00000	0.000
323	Vline wall PACS I/F 1	2.456	0.00000	0.00000	0.000
324	Vline wall PACSI/F1/2	2.286	0.00000	0.00000	0.003
325	Vline wall PACSI/F1/2	2.314	0.00000	0.00000	0.013
326	Vline wall PACS I/F 2	2.681	0.00000	0.00000	0.000
327	Vline wall PACS I/F 2	2.831	0.00000	0.00000	0.000
328	Vline wall PACS I/F 2	2.741	0.00000	0.00000	0.000
329	Vline wall PACSI/F2/3	2.649	0.00000	0.00000	0.005
330	Vline wall PACSI/F2/3	2.714	0.00000	0.00000	0.002
331	Vline wall PACS I/F 3	2.847	0.00000	0.00000	0.000
332	Vline wall PACS I/F 3	2.952	0.00000	0.00000	0.000
333	Vline wall PACS I/F 3	2.904	0.00000	0.00000	0.000
334	Vline wall PACS-SPIRE	2.860	0.00000	0.00000	0.005
335	Vline wall PACS-SPIRE	2.882	0.00000	0.00000	0.007
336	Vline wall PACS-SPIRE	3.035	0.00000	0.00000	0.008
337	Vline wall SPIRE	3.951	0.00000	0.00000	0.000
338	Vline wall SPIRE	4.484	0.00000	0.00000	0.000
339	Vline wall SPIRE	4.232	0.00000	0.00000	0.000
340	Vline wall SPIRE-HIFI	4.022	0.00000	0.00000	0.011
341	Vline wall SPIRE-HIFI	4.036	0.00000	0.00000	0.014
342	Vline wall SPIRE-HIFI	4.136	0.00000	0.00000	0.017
343	Vline wall HIFI	5.033	0.00000	0.00000	0.000
344	Vline wall HIFI	5.559	0.00000	0.00000	0.000
345	Vline wall HIFI	5.851	0.00000	0.00000	0.000
346	Vline Lev.2 OB	9.808	0.00000	0.00000	0.065
347	Vline Lev.2 OB	10.884	0.00000	0.00000	0.189
348	Vline Lev.2 OB	11.005	0.00000	0.00000	0.076
349	Vline Lev.2 OB	11.078	0.00000	0.00000	0.122
350	Vline Lev.2 OB	11.107	0.00000	0.00000	0.072
351	Vline Lev.2 OB	11.113	0.00000	0.00000	0.212
352	Vline Lev.2 OB	11.138	0.00000	0.00000	0.109
371	Opt. Bench +Z	11.024	0.00000	0.00000	7.232
372	Opt. Bench +Z -Y	10.956	0.00000	0.00000	6.562
373	Opt. Bench +Z mid	11.037	0.00000	0.00000	17.012
374	Opt. Bench +Z +Y	11.054	0.00000	0.00000	2.757
375	Opt. Bench -Y	11.107	0.00000	0.00000	12.612
376	Opt. Bench centre	11.089	0.00000	0.00000	30.360
377	Opt. Bench +Y	11.093	0.00000	0.00000	6.686
378	Opt. Bench -Z -Y	11.141	0.00000	0.00000	6.895
379	Opt. Bench -Z mid	11.117	0.00000	0.00000	17.377
380	Opt. Bench -Z +Y	11.118	0.00000	0.00000	2.804
381	Opt. Bench -Z	11.114	0.00000	0.00000	7.407
390	I.Shld HIFI Baf. ext.	11.371	0.00000	0.00000	0.300
391	I.Shld HIFI Baf. int.	11.299	0.00000	0.00000	0.105
411	MLI on OB-Shield side	13.793	0.00000	0.00000	31.383
412	MLI on OB-Shield top	13.797	0.00000	0.00000	40.526
710	PACS-Top Optic	3.133	0.00000	0.00000	1.867
720	PACS-Spectrometer	3.131	0.00003	0.00000	2.110
725	PACS-Collimator	3.128	0.00000	0.00000	2.134
730	PACS-Photometer Optic	3.127	0.00000	0.00000	1.288
735	PACS-Internal	3.132	0.00000	0.00000	1.790
740	PACS-Lump	3.132	0.00000	0.00000	0.000
750	PACS-Chopper	3.136	0.00040	0.00000	0.113

755	PACS-Grating Assy	3.135	0.00100	0.00000	0.769
760	PACS-Red Detector	1.704	0.00000	0.00000	0.230
761	PACS-Red Detect. CRE	3.143	0.00030	0.00000	0.000
765	PACS-Blue Detector	1.723	0.00013	0.00000	0.233
766	PACS-Blue Detect. CRE	3.143	0.00030	0.00000	0.000
770	PACS-Filter Wh. Blue	3.131	0.00004	0.00000	0.131
771	PACS-Filter Wh. Photo	3.127	0.00004	0.00000	0.131
775	PACS-Calib. Source 1	3.134	0.00032	0.00000	0.000
776	PACS-Calib. Source 2	3.136	0.00032	0.00000	0.000
780	PACS-Photometer Housi	3.129	0.00000	0.00000	0.989
781	PACS-Photometer CooPu	1.781	0.00220	0.00000	0.147
791	PACS-STST-Strut 1,1	8.952	0.00000	0.00000	0.318
792	PACS-STST-Strut 4,1	8.948	0.00000	0.00000	0.495
793	PACS-STST-Strut 5,1	8.951	0.00000	0.00000	0.248
794	PACS-Kevlar-Strut Red 1	2.597	0.00000	0.00000	0.000
795	PACS-Kevlar-Strut Blue 1	2.601	0.00000	0.00000	0.000
796	PACS-HarnessRed Det.Intl	2.533	0.00000	0.00000	0.000
797	PACS-HarnessBlueDet.Intl	2.539	0.00000	0.00000	0.000
798	PACS-HarnessBlue1.7->4,1	2.524	0.00000	0.00000	0.000
801	SPIRE PM JFET ENCL	11.147	0.01026	0.00000	10.522
802	SPIRE SM JFET ENCL	11.122	0.00282	0.00000	3.411
803	SPIRE Optical Bench	5.095	0.00000	0.00000	9.568
804	SPIRE RF Filter Box	5.099	0.00428	0.00000	0.469
805	SPIRE Beam St. Mech	5.095	0.00100	0.00000	0.351
806	SPIRE SMECm	5.095	0.00048	0.00000	0.415
807	SPIRE PM calibrator	5.095	0.00002	0.00000	0.000
808	SPIRE SM calibrator	9.361	0.00040	0.00000	0.000
809	SPIRE Shutter	5.095	0.00000	0.00000	0.000
810	SPIRE PM Detector en	1.795	0.00000	0.00000	0.451
811	SPIRE SM Detector en	1.772	0.00000	0.00000	0.269
812	SPIRE PM Detectors	1.741	0.00000	0.00000	0.398
813	SPIRE SM detector	1.741	0.00000	0.00000	0.252
816	SPIRE Cooler Pump	1.887	0.00183	0.00000	0.000
817	SPIRE Cooler shunt	1.725	0.00000	0.00000	0.000
818	SPIRE Cooler evap	1.741	0.00000	0.00000	0.000
819	SPIRE Cooler pump HS	1.773	0.00008	0.00000	0.000
820	SPIRE Cooler evap HS	1.724	0.00000	0.00000	0.000
900	HIFI 2K level	1.853	0.00014	0.00000	0.000
905	HIFI Harness 1 int.point	5.942	0.00036	0.00000	0.000
910	HIFI FPU Structure	11.121	0.01602	0.00000	99.146
912	HIFI L0 boundary node	1.847	0.00000	0.00000	0.000
913	HIFI L1 boundary node	5.817	0.00000	0.00000	0.000
914	HIFI Harness 2a int.poin	12.522	0.00036	0.00000	0.000
915	HIFI Harness 2b int.poin	8.863	0.00000	0.00000	0.000
920	HIFI Internal Assy.	5.821	0.00000	0.00000	0.023
5000	GHe tank outlet	1.700	0.00000	0.00000	0.000
5010	GHe PACS I/F 1 in	1.750	0.00000	0.00000	0.000
5011	GHe PACS I/F 1	1.955	0.00000	0.00000	0.000
5012	GHe PACS I/F 1	2.086	0.00000	0.00000	0.000
5013	GHe PACS I/F 1 out	2.214	0.00000	0.00000	0.000
5014	GHe PACS I/F 1/2	2.267	0.00000	0.00000	0.000
5020	GHe PACS I/F 2 in	2.311	0.00000	0.00000	0.000
5021	GHe PACS I/F 2	2.447	0.00000	0.00000	0.000
5022	GHe PACS I/F 2	2.530	0.00000	0.00000	0.000
5023	GHe PACS I/F 2 out	2.610	0.00000	0.00000	0.000
5024	GHe PACS I/F 2/3	2.645	0.00000	0.00000	0.000
5030	GHe PACS I/F 3 in	2.690	0.00000	0.00000	0.000
5031	GHe PACS I/F 3	2.751	0.00000	0.00000	0.000
5032	GHe PACS I/F 3	2.797	0.00000	0.00000	0.000
5033	GHe PACS I/F 3 out	2.839	0.00000	0.00000	0.000
5034	GHe PACS-SPIRE	2.858	0.00000	0.00000	0.000
5035	GHe PACS-SPIRE	2.880	0.00000	0.00000	0.000
5040	GHe SPIRE I/F in	3.027	0.00000	0.00000	0.000

5041	GHe SPIRE I/F	3.449	0.00000	0.00000	0.000
5042	GHe SPIRE I/F	3.740	0.00000	0.00000	0.000
5043	GHe SPIRE I/F out	3.977	0.00000	0.00000	0.000
5044	GHe SPIRE-HIFI	4.020	0.00000	0.00000	0.000
5045	GHe SPIRE-HIFI	4.035	0.00000	0.00000	0.000
5050	GHe HIFI I/F in	4.131	0.00000	0.00000	0.000
5051	GHe HIFI I/F	4.595	0.00000	0.00000	0.000
5052	GHe HIFI I/F	4.902	0.00000	0.00000	0.000
5053	GHe HIFI I/F out	5.429	0.00000	0.00000	0.000
5054	GHe Lev.2 OB	9.590	0.00000	0.00000	0.000
5055	GHe Lev.2 OB	10.820	0.00000	0.00000	0.000
5056	GHe Lev.2 OB	10.996	0.00000	0.00000	0.000
5057	GHe Lev.2 OB	11.074	0.00000	0.00000	0.000
5058	GHe Lev.2 OB	11.105	0.00000	0.00000	0.000
5059	GHe Lev.2 OB	11.113	0.00000	0.00000	0.000
5060	GHe Lev.2 OB	11.136	0.00000	0.00000	0.000
6059	X3 SI Harness 59	11.973	0.00406	0.00000	0.000
6069	X3 JF Harness 69	18.423	0.00040	0.00000	0.000
9999	Ambient Air	293.000	0.00000	0.00000	0.000

+EQM7:CTCE

NODE	LABEL	T	QI	QR	C
900	Vacuumtight Plate	290.453	0.00000	0.00000	6968.004
1100	Radiation shield 2	23.199	0.00000	0.00000	6.448
1200	Radiation shield 1	6.381	0.00000	0.00000	0.243
1310	RS1 cyl. MLI	8.669	0.00000	0.00000	0.000
1320	RS1 disc MLI	8.669	0.00000	0.00000	0.000
1410	RS2 cyl. MLI	274.852	0.00000	0.00000	0.000
1420	RS2 disc MLI	277.418	0.00000	0.00000	0.000
1500	Mirror&Support	5.268	0.00000	0.00000	1.176
2000	CTA-Shroud Dewar	4.200	0.00000	0.00000	0.000
2001	GHe Shroud 1500 out	5.095	0.00000	0.00000	0.000
2002	GHe Shroud 1200 out	6.229	0.00000	0.00000	0.000
2003	GHe Shroud 1100 out	22.354	0.00000	0.00000	0.000
2004	GHe Shroud 900 out	198.651	0.00000	0.00000	0.000
9999	AMBIENT	293.000	0.00000	0.00000	0.000

Heat Balance for PAYLOAD incl. Instrument Shield MLI

=====		
Level 0: from Aux. Tank into instruments	-15.556	[mW]
Level 2: from spatial framework into OB	-0.699	[mW]
Level 1/2: from Aux. Tank into OB via ventline wall	-0.061	[mW]
Level 2: from HS1 into OB via ventline wall	0.164	[mW]
Level 2: via harness into OB	27.226	[mW]
via radiation from HS1 upper bulkhead onto Instrument MLI	0.244	[mW]
via radiation from Cryostat cavity onto OB lower side	5.132	[mW]
via radiation from HS1-baffle into payload	0.007	[mW]
via radiation from HS2-baffle into payload	0.023	[mW]
via radiation from HS3-baffle into payload	1.507	[mW]
via radiation from CTA mirror into payload	-0.001	[mW]
via radiation from CVV-LOU-Window onto HIFI-Baffle	19.928	[mW]
via radiation from CVV-LOU-Window onto HIFI-FPU	14.494	[mW]
Vent line cooling power (out of payload)	102.299	[mW]
Transferred by convection from PL-ventline on helium	102.328	[mW]
total dissipation of PACS	5.070	[mW]
total dissipation of SPIRE	21.167	[mW]
total dissipation of HIFI	16.867	[mW]
Harness dissipation on OB	4.462	[mW]
Payload Heat Imbalance (shall be 0)	-2.324	[mW]

Heat Balance for Main Tank Ventline

=====		
conducted and radiated into ventline attached to HS1	3203.508	[mW]
conducted and radiated into ventline attached to HS2	5785.343	[mW]
conducted and radiated into ventline attached to HS3 +Z	19166.800	[mW]
conducted and radiated into ventline attached to HS3 -Z	19140.978	[mW]
conducted into ventline walls from CVV	56918.808	[mW]
conducted and radiated into line baf to HS 1	0.152	[mW]
Main Tank Ventline cooling power (out of ventline)	104215.684	[mW]
Via convection into ventline walls	-104225.575	[mW]
Main Tank Ventline Imbalance (shall be 0)	-0.096	[mW]

Heat Balance for CTA-Cold Plate

=====		
Convective heat transfer onto CTA vacuumtight plate	1715.117	[mW]
Conducted from CVV into CTA vacuum tight plate	8341.082	[mW]
Radiated from Payload onto CTA mirror	0.001	[mW]
Radiated from HS-baffles onto CTA-Radiation Shield 1	48.658	[mW]
Cooling power of CTA-heatshields	10104.859	[mW]
CTCE Imbalance (shall be 0)	-0.001	[mW]

Heat Balance for whole Cryostat including Payload, Ventlines and CTCE

=====		
Convective heat transfer onto external walls	114255.138	[mW]
total heat transferred on gaseous helium	114422.843	[mW]
evaporation power in main and aux. tank	2087.182	[mW]
Total instrument power dissipation	43.104	[mW]
total main & auxiliary tank heater power	2014.000	[mW]
heater power of CVV lower bulkhead HTR	0.000	[mW]
total harness dissipation within system	19.601	[mW]
Cooling power of CTCE-shrouds	10104.859	[mW]
Cryostat total imbalance (shall be 0)	-178.182	[mW]

Heat Balance for Main Tank

=====		
Main tank dissipation + heater power	2000.000	[mW]
radiated from aux. tank	0.000	[mW]
conducted from spatial framework	29.528	[mW]
transferred through MLI	9.744	[mW]
conducted from rest	0.290	[mW]
radiated from spatial framework and HSs	0.077	[mW]
conducted from main tank ventline wall	0.000	[mW]
radiated from payload	0.000	[mW]
total heat into main tank	2039.638	[mW]

Heat Balance for Auxiliary Tank

=====

Aux. tank dissipation + heater power	14.000 [mW]
heat from Ti-heads via mech. I/F	2.215 [mW]
radiated from Main tank	0.000 [mW]
radiated from spatial framework and HSs	0.015 [mW]
conducted from payload L0	15.556 [mW]
conducted from payload L2	0.061 [mW]
radiated from payload	0.011 [mW]
conducted from filling tube	0.007 [mW]
radiated from MLI filling tube	15.678 [mW]
total heat into Aux. tank	47.544 [mW]

Heat flows into Tanks

=====

Into Main Tank	2039.638 [mW]
Into Aux. Tank	47.544 [mW]

Helium evaporation mass flow rates

=====

Out of Main Tank	97.497 [mg/s]
Out of Aux. Tank	2.086 [mg/s]
Out of external He- dewar for CTA-shroud cooling	10.000 [mg/s]

5.7 Transient Thermal Analysis

5.7.1 Cool-down of CTCE-Cryostat, Design Concept 2

The cool-down of the CTCE-cryostat (design concept 2) as defined in § 4.5.2.2 is thermally analysed. Herewith the following initial conditions are assumed:

- EQM-Cryostat already cooled-down and in thermodynamic equilibrium
- Main tank heater power = 2000 mW and kept constant
- Auxiliary tank heater power = 14 mW and kept constant
- Instruments permanently dissipating at “average orbit” conditions
- CTCE helium mass flow rate = zero at $t < 0$ (cooling off)
- CTCE helium mass flow rate = 300 mg/s at $t = 0$ (cooling switched on) and kept constant

Thermal analysis is carried out for a period of 24 hours. It revealed that this is not sufficient to reach steady-state conditions.

The resulting cool-down temperature charts are depicted in Figure 5-1 thru Figure 5-7. The corresponding nodal description can be found in § 4.5.2.2. Note that only the shroud and heatshield 2 is ventline-cooled (Figure 5-2). Heatshield 1 and 3 are only cooled by radiation.

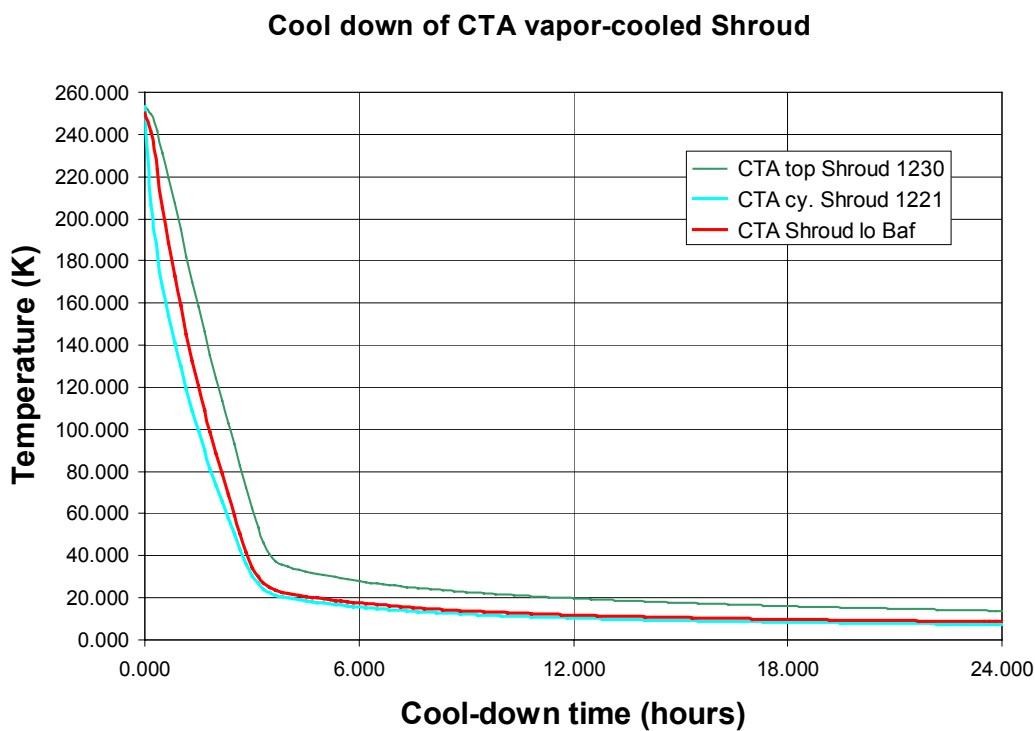

Figure 5-1: Temperature evolution of CTA-shrouds during cool-down of CTA

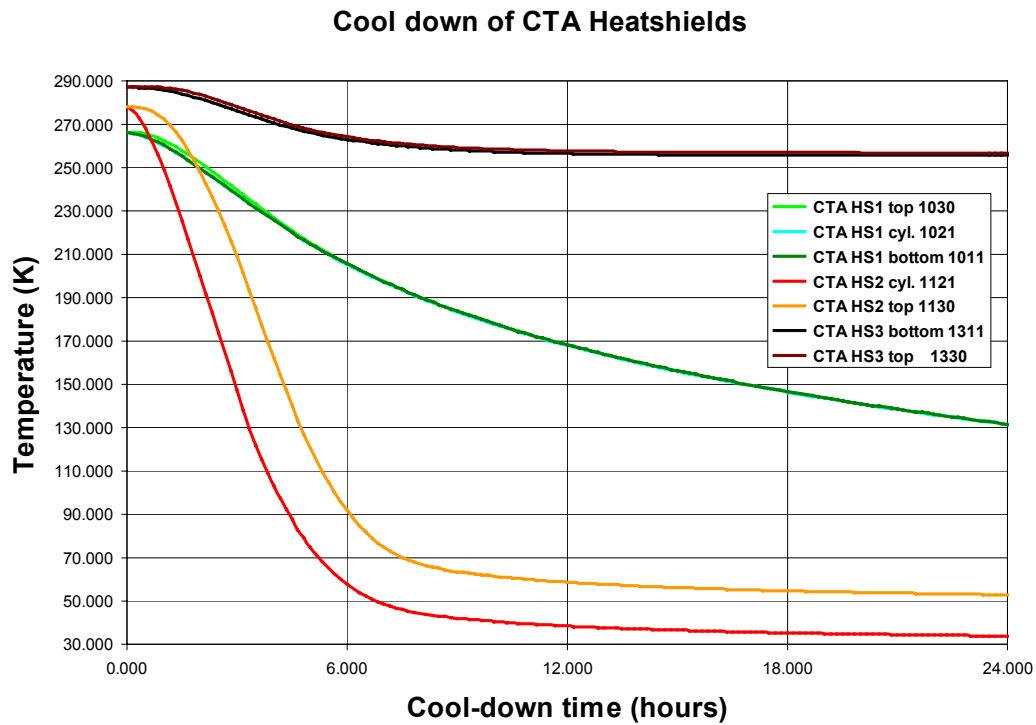

Figure 5-2: Temperature evolution of CTA-heatshields during cool-down of CTA

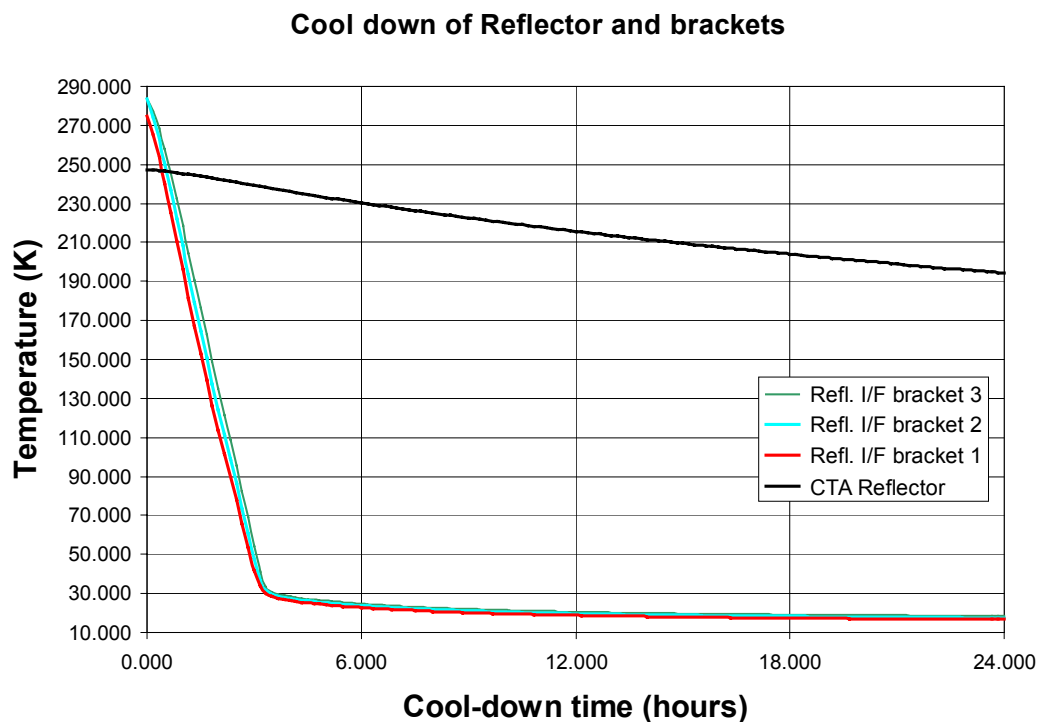

Figure 5-3: Temperature evolution of CTA-reflector during cool-down of CTA

Cool down of HOB

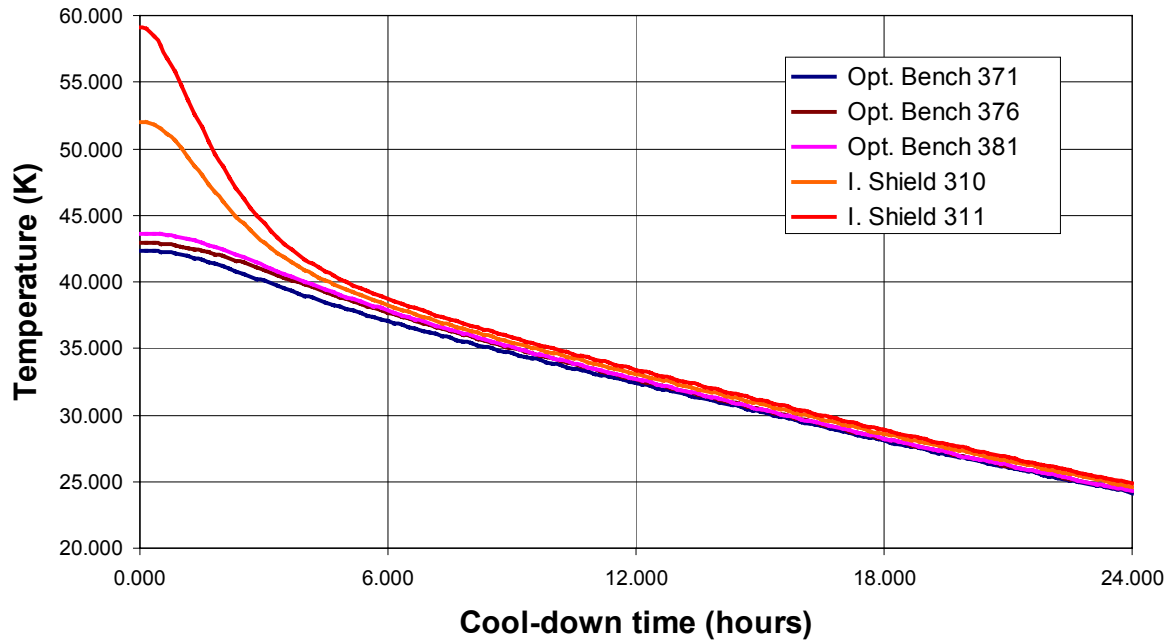

Figure 5-4: Temperature evolution of HERSCHEL Optical Bench during cool-down of CTA

Cool down of Instrument Level 1 Interfaces

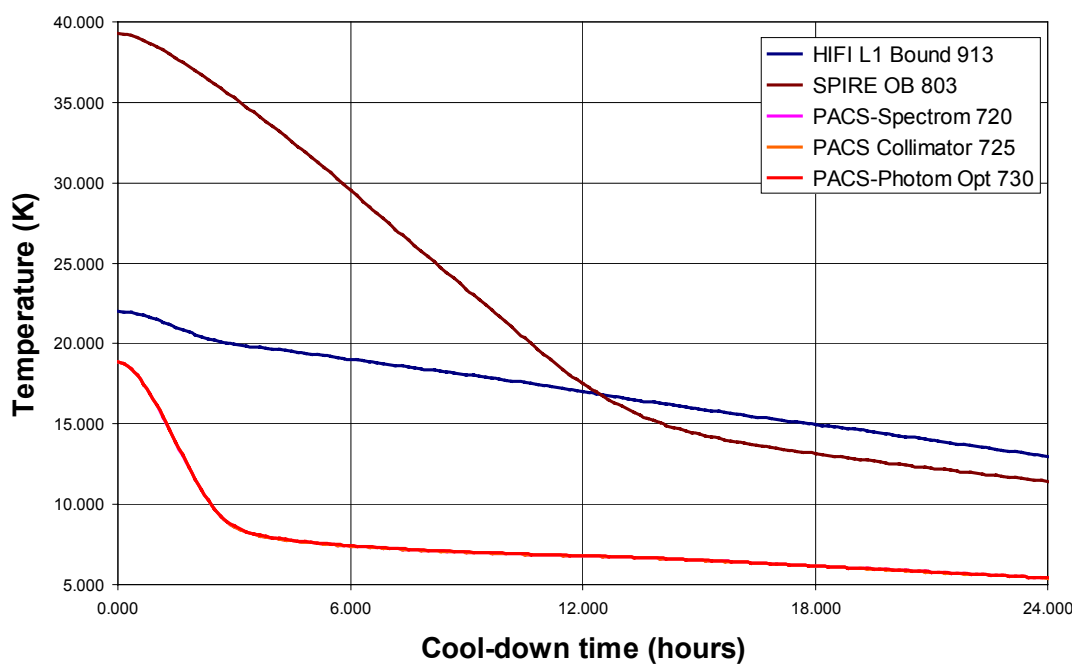

Figure 5-5: Temperature evolution of Instruments during cool-down of CTA

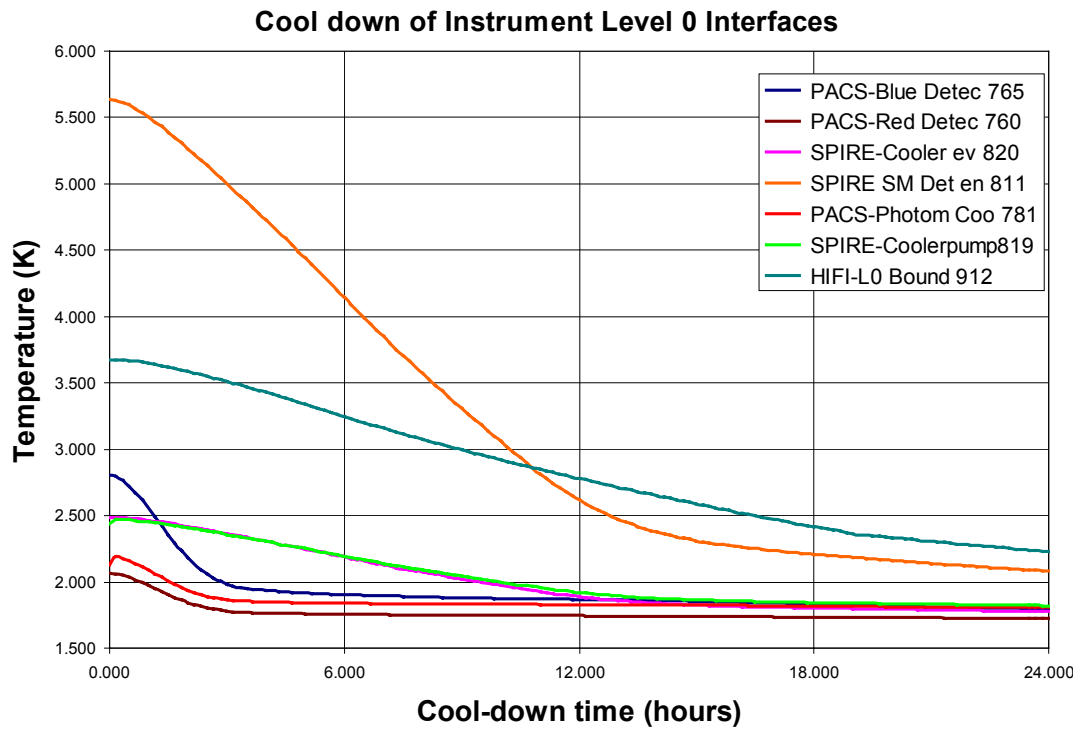

Figure 5-6: Temperature evolution of Instruments during cool-down of CTA

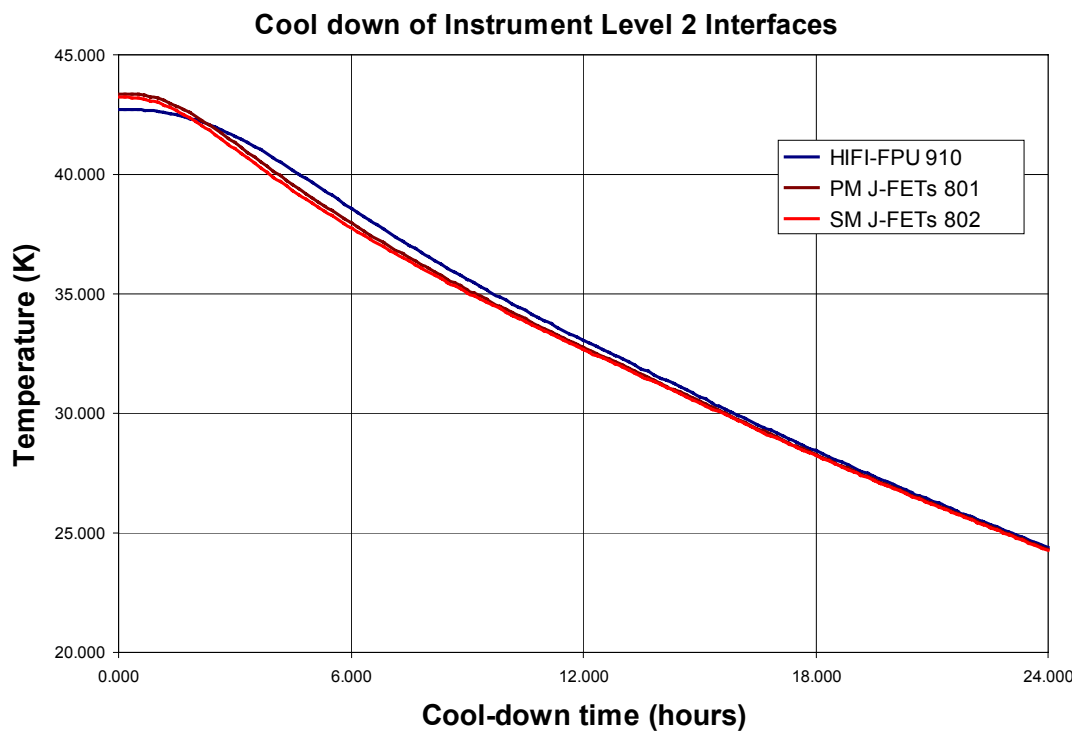

Figure 5-7: Temperature evolution of Instruments during cool-down of CTA

5.7.2 Cool-down of CTA Cold Plate Design

The cool-down of the CTA cold plate (design 1 with black mirror) as defined in § 4.6 is thermally analysed. Herewith the following initial conditions are assumed:

- EQM-Cryostat already cooled-down and in thermodynamic equilibrium
- Main tank heater power = 2000 mW and kept constant
- Auxiliary tank heater power = 14 mW and kept constant
- Instruments permanently dissipating at “average orbit” conditions
- CTA helium mass flow rate = zero at $t < 0$ (cooling off)
- CTA helium mass flow rate = 50 mg/s at $t = 0$ (cooling switched on) and kept constant

Thermal analysis is carried out for a period of 24 hours. It revealed that this is not sufficient to reach steady-state conditions. The resulting cool-down temperature charts are depicted in Figure 5-8 thru Figure 5-11.

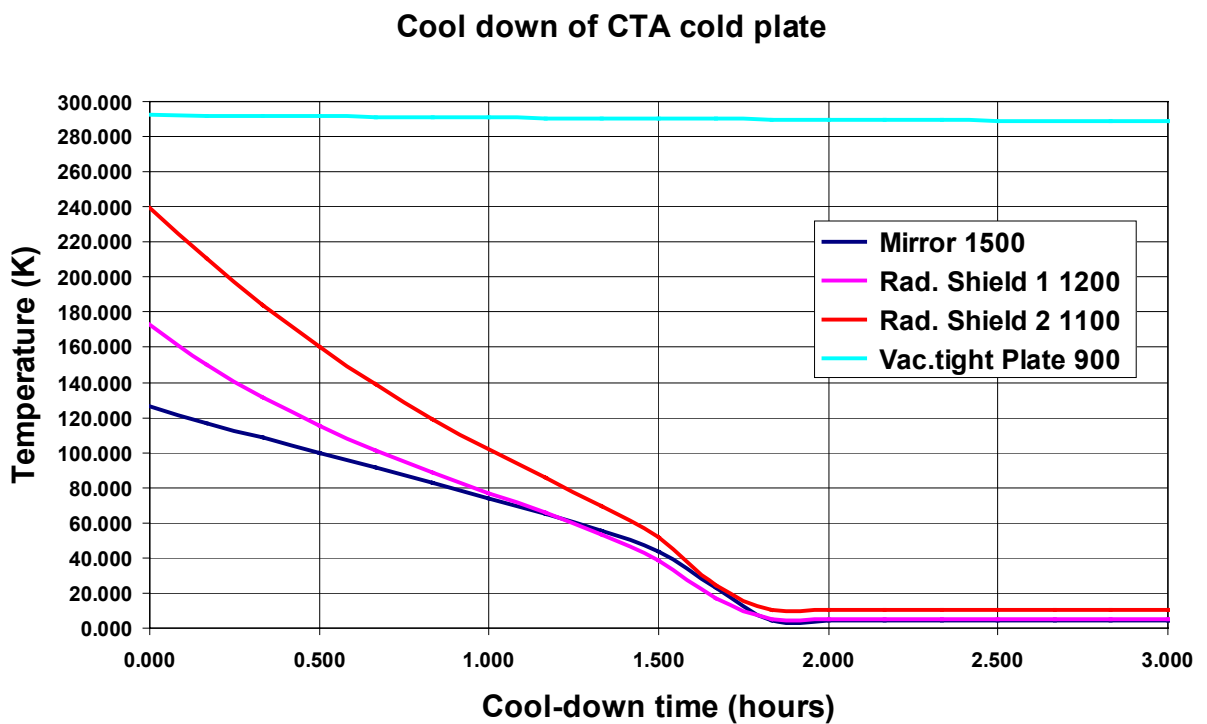

Figure 5-8: Temperature evolution of CTA during cool-down of CTA

Cool down of HOB

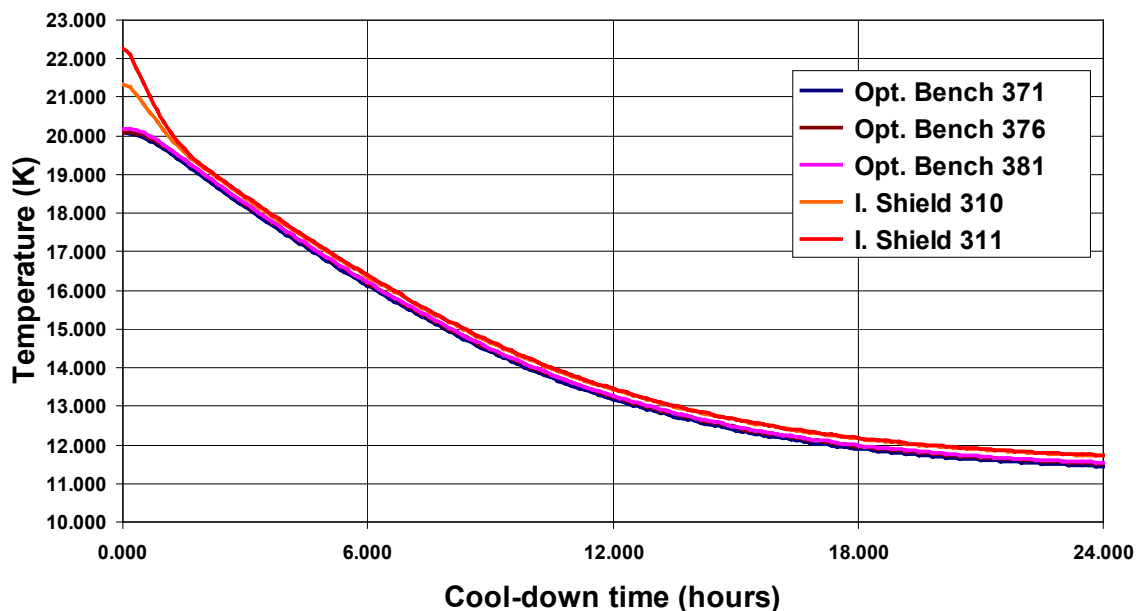

Figure 5-9: Temperature evolution of HERSCHEL Optical Bench during cool-down of CTA

Cool down of Instrument Level 0 Interfaces

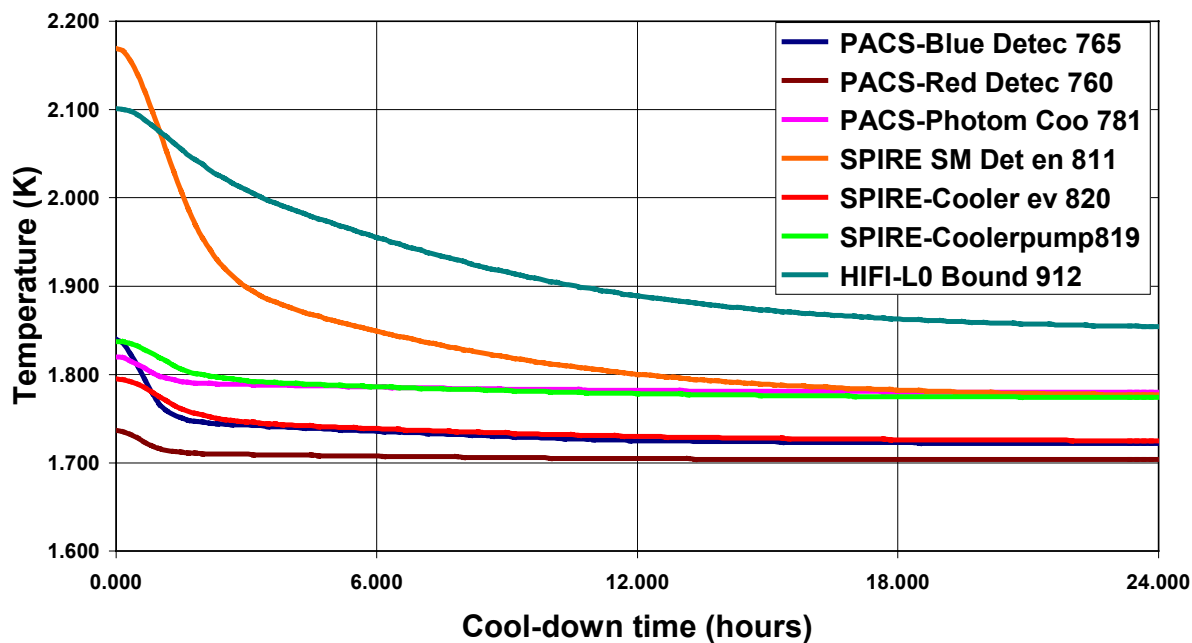

Figure 5-10: Temperature evolution of Instruments during cool-down of CTA

Cool down of Instrument Level 2 Interfaces

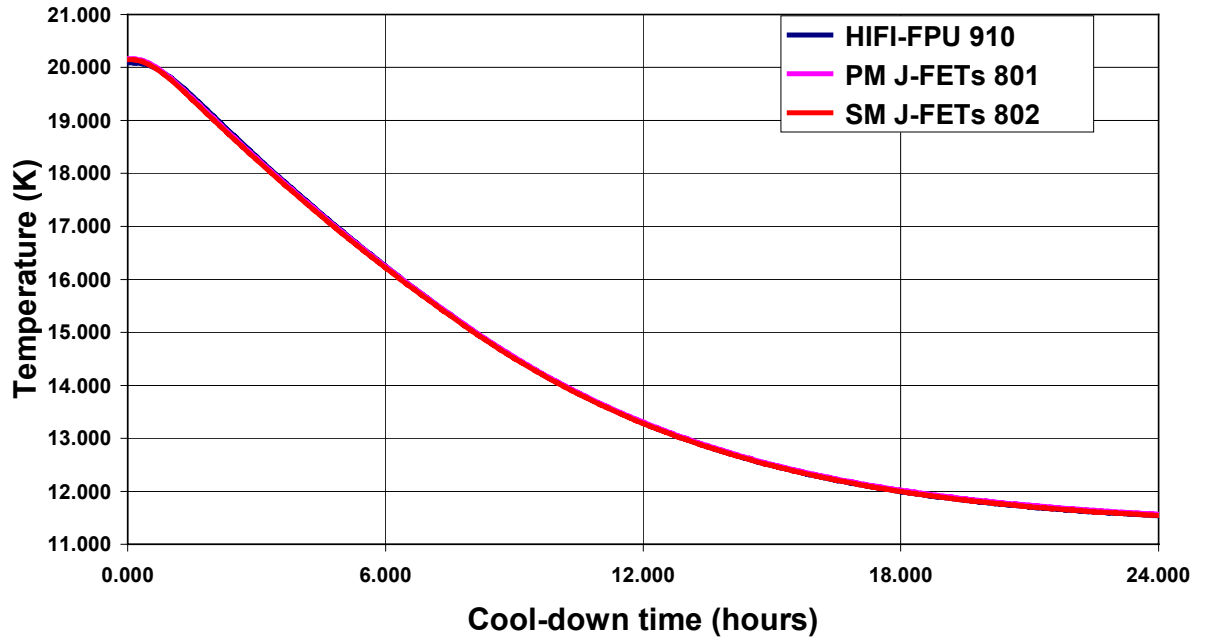

Figure 5-11: Temperature evolution of Instruments during cool-down of CTA

6 Ventline Pressure Drop Analysis

6.1 Pressure Drop within EQM-Auxiliary Tank Ventline

The pressure drop is assumed to be identical to the HPLM pressure drop (see RD 03). For this reason no extra analysis is performed for the EQM.

6.2 Pressure Drop within the EQM-main Tank Ventline

The pressure in the main tank is 990 mbar corresponding to the saturation pressure at 4.2 K (analysis value). A simplified MATCHCAD-analysis has been performed assuming a linear temperature increase of the helium from 4.2 K to 210 K (at node 297) along a total pipe length of approx. 13 m.

The result is a pressure drop of 19 mbar which is absolutely not critical.

6.3 Pressure Drop within the CTCE Ventline

The pressure in the external dewar is 990 mbar corresponding to the saturation pressure at 4.2 K (analysis value). A simplified MATCHCAD-analysis has been performed assuming a linear temperature increase of the helium from 4.2 K to 60K (at node 2018) along a total pipe length of approx. 16 m.

The result is a pressure drop of only 2.5 mbar which is also absolutely not critical.

7 Conclusions

It has been demonstrated by thermal analysis that the EQM-configuration as proposed in this report is feasible. All thermal requirements in order to achieve the thermal EQM-testobjectives can be fulfilled. The HERSCHEL OB with instruments can be controlled within the required flight-representative temperature ranges. It has also been shown that the required flight-representative mass flow rate through the payload-ventline can be adjusted by adequate heating of the EQM-auxiliary tank. It has also been demonstrated that the main-tank-venting/heating concept is suitable to obtain the adequate heatshield cooling.

It is not necessary to cover the EQM-aux. Tank with MLI blankets which saves a lot of costs. Blank or alodine-coated low-emissive alu ($\epsilon = 0.05$) is sufficient.

It has been shown that the EQM.-auxiliary tank mounting devices underlying this report are adequate. The heat flow across this interface into the aux. tank is very small.

The 4.5 K requirement at the SPIRE level-1 interface has not yet been agreed by ASSED. In order to reduce the temperature, there is still a little margin in the mass flow rate. In the analysis 2.0 mg/s are considered corresponding to 14 mW heater power, but 2.1 mg/s are required. Thus, the 2.1 mg/s will be obtained by slightly increasing the heater power, resulting in a small temperature reduction at the L1-interface (#803).

Both proposed CTCE design concepts with and without MLI are feasible from thermal point of view. The reflector needs not to be ventline-cooled during instrument testing when mounted on interface brackets or onto a separate optical bench connected to the ventline as proposed in this report. Transient analysis, however, indicated that weeks of cool-down would be required to reach thermodynamic equilibrium for the reflector. For this reason it is recommended to provide an extra cooling loop for the reflector in order to enhance cool-down. For this purpose a LN2-system would be adequate. To stabilize the reflector at a desired temperature level it is recommended to switch off the LN2-cooling and control the temperature with the help of an electrical heater-system. This would be significantly less comprehensive than by a temperature or mass-flow-controlled ventline system.

From thermal point of view the "vacuum-tight cover plate design" with ventline-cooled mirror and heatshields and MLI in-between is also feasible. Mirror temperatures down to 5 K could be adjusted. To achieve this an adequate thermal isolation between the shields as well as of the ventline from the vacuum-tight plate would be required. Anyway the vacuum-tight plate design without reflector and black body target stands out for its simplicity compared to the CTCE-cryostat design concepts enabling considerable cost savings.

Critical Aspects:

Since the EQM- auxiliary tank is smaller in diameter than the HERSCHEL-OB the overall thermal links connecting the L0- tank interfaces with the instrument L0-interfaces differ from the PFM-design. It is recommended to modify only the rigid parts and to use the same flexible links as for the PFM.

Anyway the thermal performance of the EQM-L0-links shall be at least the same as for the PFM. This can be achieved by an adequate dimensioning of cross-sections and flange areas. This is judged to

be uncritical with regard to mass and mechanical load constraints (EQM sees no vibration tests), however, might be critical due to limited space and due to AIV constraints.

The filling tube should be thoroughly wrapped in MLI since it has been shown by thermal analysis of this report as well as in the ISO-project that the heat flow into the HOB and Aux.-tank is significant.

The CTCE-shroud that is ventline-cooled below 5 K must be thermally very well coupled to the shroud baffle as shown in this report. This baffle is mandatory in order to prevent the instruments from IR-illumination emitted by HS 2 and HS 3 of the HERSCHEL cryostat.

For the same reason the radiation shields of the "vacuum-tight cover plate design" shall be designed as "pots" in order to close the circumferential gaps between the heatshields of the EQM-CVV upper bulkhead.

The ventline pipes of the "vacuum-tight cover plate design" shall be made of low-conductive stainless steel and shall be thermally isolated from the vacuum-tight plate that is at ambient temperature.

END OF DOCUMENT

Quantity	Name	Dep./Comp.	Quantity	Name	Dep./Comp.
1	Alberti von Mathias Dr.	ED 544		Runge Axel	OTN/TN 94
	Barlage Bernhard	ED 62		Sachsse Bernt	EC 34
	Bayer Thomas	ED 532		Sagner Udo	OTN/TN 64
1	Faas Horst	ED 516		Schäffler Johannes	OTN/TN 64
	Grasl Andreas	OTN/TN 64		Schink Dietmar	ED 522
	Grasshoff Brigitte	ED 511	1	Schlosser Christian	OTN/TN 64
1	Hartmann Hans Dr.	ED 172	1	Schabbauer Paul Dr.	OTN/ED171
1	Hauser Armin	ED 541		Schweickert Gunn	ED 544
1	Hinger Jürgen	ED 541		Steininger Eric	ED 522
1	Hohn Rüdiger	ED 531	1	Stritter Rene	ED 61
1	Hölzle Edgar	ED 171		Tenhaeff Dieter	ED 544
1	Huber Johann	ED 532		Thörmer Klaus-Horst Dr.	OTN/ED 37
	Hund Walter	ED 556		Wagner Adalbert	OTN/IP 35
1	Idler Siegmund	ED 521	1	Wagner Klaus	ED 541
	Ivány von András	EC 32		Wietbrock, Walter	ED 511
1	Jahn Gerd Dr.	ED 541	1	Wilz Eberhard	OTN/ED 37
1	Kalde Clemens	ED 513		Wöhler Hans	ED 544
	Kameter Rudolf	OTN/TN 64		Ziegler Fred	OTN/ED 522
	Knoblauch August	ED 51		Zipf Ludwig	EC 32
	Koelle Markus	ED 533			
1	Kroeker Jürgen	ED 515			
	Lamprecht Ernst	OTN/TN 72			
	Lang Jürgen	ED 556			
1	Langfermann Michael	ED 531			
	Mack Paul	OTN/TN 64		Pastorino Michel	ASPI Resid.
1	Maier Hans-Ulrich	ED 61			
	Mauch Alfred	ED 544	1	Alcatel (on FTP-Server)	
1	Moritz Konrad Dr.	ED 37	1	ESTEC (on FTP-Server)	
	Müller Lutz	OTN/TN 64			
	Muhl Eckhard	OTN/TN 64			
	Peitzker Helmut	ED 37		APCO	
	Peltz Heinz-Willi	ED 515		MPGE	
	Peters, Gerhard	ED 533		RALA	
	Pietroboni Karin	ED 37		SRON	
	Puttlitz Joachim	OTN/ED 37			
	Raupp Helmut	ED 543			
	Rebholz Reinhold	ED 531			
	Reuß Friedhelm	ED 7			
1	Rühe Wolfgang	ED 3			