

Title: **H-EPLM Thermal Model and Analysis**

CI-No: 120 000

Prepared by:	<u>K. Wagner</u> <i>K. Wagner</i>	Date:	<u>08.08.2007</u>
Checked by:	<u>J. Kroeker, G. Jahn</u> <i>J. Kroeker</i>		<u>9.8.2007</u>
Product Assurance:	<u>R. Stritter</u> <i>R. Stritter</i>		<u>09.08.07</u>
Configuration Control:	<u>W. Wietbrock</u> <i>W. Wietbrock</i>		<u>10.08.07</u>
Project Management:	<u>W. Fricke</u> <i>W. Fricke</i>		<u>10/08/2007</u>

Distribution: See Distribution List (last page)

Copying of this document, and giving it to others and the use or communication of the contents thereof, are forbidden without express authority. Offenders are liable to the payment of damages. All rights are reserved in the event of the grant of a patent or the registration of a utility model or design.

Issue	Date	Page	Description of Change	Release
1	30.11.01	all	First Issue	
2Draft	11.06.02	all	<p>Draft Issue for PDR</p> <p><u>Sect. 5.3:</u></p> <ul style="list-style-type: none"> - HTT, HOT, TS1 and innermost tank suspension straps implemented in ESARAD Geometry Model, - Heat shield Beam entrance baffles merged to a common baffle with 0.8 emissivity and attached to TS2 only, - Cryostat Baffle Insert with 500 mm diameter introduced, - Telescope opening changed from 360 mm to 560 mm. <p><u>Sect. 5.4:</u></p> <ul style="list-style-type: none"> - +Y Radiator rotated by 14° towards Y axis (to avoid collision with filling port), - emissivity of CVV main radiator changed from 0.8 to 0.7, - emissivity of CVV ±Y and –Z Radiator changed from 0.9 to 0.8. <p><u>Sect. 5.5:</u></p> <ul style="list-style-type: none"> - Waveguides implemented in ESARAD Geometry Model, - LOU harness updated acc. to RD 02, - LOU radiator design updated acc. to ECP HP-2-ASED-CP-001, - Telescope mechanical fixation on CVV changed from GFRP struts to T300 CFRP struts, - BOLA direct mounted on CVV and covered with MLI <p><u>Sect. 5.6:</u></p> <ul style="list-style-type: none"> - Scientific harness updated acc. to RD 02, - Thermalization of SPIRE JFET harness shifted from TS 1 to TS 2. <p><u>Sect. 5.7:</u></p> <ul style="list-style-type: none"> - HSS update acc. to. Drawing Set Status “Begin 2002”. <p><u>Sect. 5.8:</u></p> <ul style="list-style-type: none"> - SVM Thermal Shield modified (+Z half deleted), - SVM top MLI set to 230 K boundary acc. to AD 07, - Cross-section to length ratio of SVM/CVV struts changed from 18.42 mm to 13.05 mm. <p><u>Sect. 6.1:</u></p>	

Issue	Date	Page	Description of Change	Release
2	17.06.02	all	<ul style="list-style-type: none"> - MLI performance data changed based on RD 08 and RD 09. <p>PDR Issue of document</p>	
2.1	10.12.02	30 35, 36 37 41 47 52 53, 55 58-64 74 79 80 86 90 91	<p>Table 5.2-2 corrected (typo: JFET dissipation in wrong column)</p> <p>Table 5.3-1 corrected (typo: 9 LOU windows instead 7)</p> <p>Explanation of CVV radiator model added as requested in PDR RID 8516</p> <p>Table 5.4-1 corrected (typo: 9 LOU windows instead 7)</p> <p>Table 5.6-2 corrected (typo: JFET harness length)</p> <p>Complete data as requested in PDR RID 8517</p> <p>Correction of SVM shield skin data acc. to TMM assumptions</p> <p>References for material data plots completed as requested in PDR RID 8517</p> <p>Table 7.4-1 corrected and completed</p> <p>Table 7.4-3 completed as requested in PDR RID 8519</p> <p>Figure 7.4-5 exchanged (copy and paste error)</p> <p>Table 7.4-6 corrected (typo: HOB temperature uncertainty)</p> <p>Introduction of Section 7.4.5 to refer to transient analyses described in RD 06</p> <p>Lifetime of PDR Collocation Status added</p>	
		Annex 1 Annex 2	<p>Temperature listings for in orbit hot and cold case as well as for ground case added as requested in PDR RID 8517</p> <p>Input Traceability Matrix added</p>	
3	09.09.03	all	<p>Document entirely modified. Major changes:</p> <ul style="list-style-type: none"> - Restructuring of H-EPLM GMM/TMM to allow Submodel structure - Refinement of CVV lower bulkhead MLI (HP-2-ASPI-TN-0366) - Increase of CVV radiator (upper bulk and Cryostat Baffle). - Refinement of Telescope Geometry based on ASEF catia model ICD-DT0018251-02-00-3D-TELESCOPE_28_05_02. - Refinement/update of ventline modelling. - Implementation of Cryo-Cooled Cover (low emissive cover shield). - Update LEOP Calculation (PPS Sample 5). - Implementation of HIFI coax cable: Precision Tube JS50141, 	

Issue	Date	Page	Description of Change	Release
			<p>JN50141.</p> <ul style="list-style-type: none"> - Refinement/update of beam entrance baffles - Removal of BOLA - Implementation of H-RSVM submodel (ASPI delivery) - Introduction of L3 interfaces. - Update of SVM Thermal Shield material (CFRP panel instead of Al panel). - Removal of Instrument Shield MLI - Introduction of 100 mm EPLM enlargement - Implementation of HSS lower stiffening ribs - Introduction of Safe Mode - Introduction of On-Ground Test Mode (IMT) - Implementation of optimized tank suspension straps - ISO TMM conductance values between suspension bolts and heat shields replaced by physical values - Update/Refinement of LOU TS2 baffle and LOU windows in H-EPLM GMM - Refinement (nodal- break-down) of Cryostat Baffle and Cryostat Baffle MLI - Update of Al 5083 thermal conductivity data (CVV) acc. to NIST data base - Implementation of HSS/SVM closure MLI - Implementation of overall instrument timeline - Update of Lifetime calculation (HP-2-ASED-TN-0065) - Implementation of Instrument Submodels, see below - Integration of PACS RTMM update (delivery date 09.05.2003) - Integration of SPIRE RTMM Issue 2.3 - Integration of HIFI RTMM update (delivery date 28.03.2003) 	
4	15.04.04	all	<p>Major changes:</p> <ul style="list-style-type: none"> - Integration of SPIRE RTMM Issue 2.5 - Refinement of nodal break down of Thermal Shields (in circumferential direction) incl. Ventline and SFW - Implementation of CDR Harness (HP-2-ASED-TN-0010, Issue 3.1) - Update of CVV internal MLI performance data (based on FZ Karlsruhe test results) - Implementation of GFRP and CFRP test data for TSS - Implementation of updated (enlarged) LOU Radiator & LOU - Implementation of Startracker heat load (200mW) - Replacement of L0 thermal link conductance requirements and L1/L3 link conductance by actual geometry and measured (temperature dependent) conductance data - Radiation in filling line - Gas conduction in cover flush line - Update of solar array thermo-optical properties - Merging of the two SPIRE L1 strap I/F points on VL to one I/F - Beam entrance: introduction of TS2 baffle aperture and IMT crown - Update of Pre-Launch/Early Orbit scenario - Update of Lifetime formula 	

Issue	Date	Page	Description of Change	Release
5Draft	16.07.07		<ul style="list-style-type: none"> - Introduction of IMT transient timeline - Update of instrument interface temperature & heat flow requirements - Update of CVV radiator thermal properties <p>Draft issue 5 for H-EPLM MQR session B</p>	
5	08.08.07	all	<p>Major changes (all changes w.r.t. issue 4):</p> <p>Section 3: List of lifetime requirements refined/IID-B conditions introduced (RFD ASED-RD-0047) Instrument I/F requirement tables adapted according to updated requirements (RFDs) and instrument models Fig. 3.2-1 (Roll & Pitch angle evolution) updated L2 orbit conditions compiled in table 3.2-1</p> <p>Section 4 (Thermal Model Description) entirely reworked, in particular: Software handling updated Section 4.2 (Lifetime calculation) updated and shifted to new section 6.5.1 Section 4.3 (H-EPLM Model with implemented Instrument Models) deleted Section 4.4 (Pressure Drop Model) updated and shifted to new section 4.4.2 Table 4.2-1 (modelling references) updated Section 4.3 (OBA, SF and Tanks) updated (figures and tables) Table 4.4-1 (Ventline tubing) refined Section 4.5.1 (PACS) updated w.r.t. L0 flexible links, dissipation profiles (Figure 4.5-3) and masses (table 4.5-1) Section 4.5.2 (SPIRE) updated w.r.t. dissipation profiles (Figure 4.5-6), masses and OBP supports (table 4.5-1) Section 4.5.3 (HIFI) updated w.r.t. add.dissipation profile (Figure 4.5-8) and L0 flexible Cu strap cross section (table 4.5-3) Section 4.6 (Thermal Shields and Tank Suspensions): figures and table 4.6-1 updated (CuBe blades added, LOU TS1 baffle added, case-dependend baffle emissivities introduced). Section 4.7 (CVV) updated w.r.t. external model refinements (radiators, ventline, plugs, harness etc.), LOU baffles, beam entrance in text, figures and tables Section 4.8 (LOU and Telescope): figures and tables refined; telescope RGMM/RTMM provided by ESA introduced Section 4.9 (Harness) updated, including harness chart (figure 4.9-1 and tables 4.9-2 to 4.9-3 (anchoring of JFET harness, refined modelling of coax, HOT depl. heater harness dissipation)</p> <p>Section 5 (Material Properties): CVV External MLI reworked Fig. 5.2-1 with updated data for GFRP struts conductivity Fig. 5.2-6 introduced</p>	

Issue	Date	Page	Description of Change	Release
			<p>Section 6 (Thermal Analysis Results) entirely reworked, in particular:</p> <p>Section 6.1.1 (Operation On Ground) updated w.r.t. heat flow chart and sensitivity tables</p> <p>Section 6.1.2 (On-Ground Autonomy) updated w.r.t. issue 5 TMM</p> <p>Section 6.1.3 (On-ground testing IMT) deleted; to be analysed separately if required (IST)</p> <p>Section 6.2 (Pre-Launch and LEOP) updated w.r.t issue 5 TMM; viewgraphs for launch phase added (figure 6.2-4)</p> <p>Section 6.3 (Spacecraft Operation in L2 Orbit) updated: analysis results including heat flow charts & sensitivity tables</p> <p>Section 6.3.3 (Transient S/C Operations) updated</p> <p>Section 6.4 (Transient instrument operations) updated</p> <p>Section 6.5.2 (Lifetime calculation) updated according to issue 5 TMM</p> <p>Section 6.6 (Instrument I/F temperatures) updated according to issue 5 TMM; additional data sets for higher massflows included; description of calculation approach added</p> <p>Annex 1 (Temperature listing) updated</p>	

Table of Content

1	SCOPE	15
2	Applicable and Reference Documents	16
2.1	Applicable Documents	16
2.2	Reference Documents	16
2.3	Abbreviations	19
3	Requirements and Boundary Conditions	20
3.1	Thermal Requirements	20
3.1.1	Lifetime	20
3.1.2	Temperature Requirements of Instruments within Cryostat	21
3.1.3	Temperature Requirements for LOU (outside Cryostat)	23
3.1.4	Temperature Requirements for Telescope	23
3.1.5	Thermal Interface Requirements for SVM	23
3.2	Thermal Environment	24
3.2.1	Ground and Pre-Launch Phase	24
3.2.2	Early Orbit Phase	24
3.2.3	Operation Phase in L2 Orbit	25
4	Thermal Model Description	27
4.1	Software and Handling	27
4.2	EPLM Configuration Breakdown for Thermal Modelling	28
4.3	Optical Bench Assembly, Spatial Framework and Tanks	31
4.4	Helium Ventline Subsystem	36
4.4.1	Modelling of Ventline	36
4.4.2	Pressure Drop Model	39
4.5	Instruments	42
4.5.1	PACS	42
4.5.2	SPIRE	46
4.5.3	HIFI	50
4.6	Thermal Shields and Tank Suspensions	54
4.7	Cryostat Vacuum Vessel and Radiators	58
4.8	LOU and Telescope	66
4.9	Harness	71

4.10	HERSCHEL Solar Array and Sunshade with Struts	76
4.11	SVM with Struts and SVM Thermal Shield	79
5	Material Properties	83
5.1	MLI Thermo-Optical Properties and Performance Data	83
5.2	Thermal Conductivity Data	86
5.3	Thermal Contact Conductance Data	91
5.4	Specific Heat Capacity Data	92
5.5	Helium Properties	93
5.6	References for Material Properties	95
6	Thermal Analysis Results	96
6.1	Operation On Ground	96
6.1.1	On-Ground Lifetime	96
6.1.2	On-Ground Autonomy (closed HTT)	99
6.2	Pre-Launch and Early Orbit Phase	101
6.3	Spacecraft Operation in L2 Orbit	107
6.3.1	Steady State Analysis for Hot and Cold Case Conditions	107
6.3.2	Sensitivity Analysis for Lifetime and EPLM Temperatures	112
6.3.3	Transient Spacecraft Operations	131
6.4	Instrument Operation in L2 Orbit	133
6.4.1	PACS Interface Temperatures and Heat Flows	134
6.4.2	SPIRE Interface Temperatures and Heat Flows	138
6.4.3	HIFI Interface Temperatures and Heat Flows	143
6.4.4	Instrument Heat Load on HTT and He Mass Flow	146
6.4.5	Sensitivity Analysis	148
6.5	Lifetime Performance	153
6.5.1	Lifetime Formula	153
6.5.2	Lifetime Calculation	154
6.6	Instrument Interface Temperatures for IID-B Allocations	155
7	Summary and Conclusions	158
8	ANNEX 1: Nodal Temperature Listing	159

Table of Figures

Figure 3.2-1:	Roll and Pitch Angle Evolution During Launch	25
Figure 3.2-2:	Solar Aspect Angles on H-EPLM at L2	26
Figure 4.3-1:	Nodal Breakdown of HTT and SFW.....	31
Figure 4.3-2:	Nodal Breakdown of Spatial Framework (detailed)	32
Figure 4.3-3:	Nodal Breakdown of Optical Bench with Instruments	33
Figure 4.3-4:	Beam Pattern for the Three Instruments.....	34
Figure 4.4-1:	Nodal Break Down of OB Ventline and Thermal Shield Ventline	37
Figure 4.5-1:	Reduced PACS Instrument TMM.....	42
Figure 4.5-2:	PACS Dissipation Profile during Operation.....	43
Figure 4.5-3:	PACS Dissipation Profile during Recycling.....	43
Figure 4.5-4:	Reduced SPIRE Instrument TMM.....	46
Figure 4.5-5:	SPIRE Dissipation Profile during Operation.....	47
Figure 4.5-6:	SPIRE Dissipation Profile during Recycling.....	47
Figure 4.5-7:	Reduced HIFI Instrument TMM.....	50
Figure 4.5-8:	HIFI Dissipation Profile during Operation.....	52
Figure 4.6-1:	Nodal Breakdown of Tank Suspensions	54
Figure 4.6-2:	Nodal Breakdown of Tanks and Thermal Shield 1	55
Figure 4.7-1:	CVV Radiator and MLI Nodal Break-Down.....	59
Figure 4.7-2:	Detailed view on CVV external items (CVV ribs, connector plugs, pretension devices, external tubing with LHVs, A-frame with nozzles, harness bundles & rails).....	60
Figure 4.7-3:	External tubing Nodal Breakdown.....	61
Figure 4.7-4:	Cryostat Baffle and Cover Nodal Break-Down (Cover open & closed View).....	62
Figure 4.7-5:	LOU Windows / Baffles	63
Figure 4.8-1:	H-EPLM GMM External Overall View including H-SVM RGMM.....	66
Figure 4.8-2:	LOU & LOU Radiator GMM.....	67
Figure 4.8-3:	Nodal Breakdown of LOU Waveguides and Harness	68

Figure 4.8-4:	Telescope GMM.....	69
Figure 4.8-5:	Scematic view of TMS.....	69
Figure 4.9-1:	Harness Chart used in TMM	71
Figure 4.10-1:	HSS Struts Nodal Breakdown.....	76
Figure 4.10-2:	HSS Nodal Breakdown	77
Figure 4.11-1:	SVM/CVV Interface Struts (numbering as per CASA I/F drawings)	79
Figure 4.11-2:	H-RSVM, SVM Thermal Shield and SVM/CVV Struts	81
Figure 5.2-1:	Thermal Conductivity of S2-Glass and E-Glass GFRP Struts	86
Figure 5.2-2:	Thermal Conductivity of CFRP T300 Struts.....	86
Figure 5.2-3:	Thermal Conductivity of CFRP M55J Struts	87
Figure 5.2-4:	Thermal Conductivity of CFRP T300 and GFRP (S-glass) Tank Suspensions [RD 35]	87
Figure 5.2-5:	Thermal Conductivity of Harness Wires.....	88
Figure 5.2-6:	Thermal Conductivity of Coax Coating	88
Figure 5.2-7:	Thermal Conductivity of Harness Wire Insulation Materials /14/	89
Figure 5.2-8:	Thermal Conductivity of Aluminium Alloys.....	89
Figure 5.2-9:	Thermal Conductivity of Titanium Alloy Ti6Al4V	90
Figure 5.2-10:	Thermal Conductivity of Thermal Link Materials [RD 35]	90
Figure 5.3-1:	Thermal Contact Conductance of Thermal Link Interfaces [RD 35]	91
Figure 5.4-1:	Specific Heat Capacity of Aluminium and Titanium /14/	92
Figure 5.5-1:	Heat of Vapourization of Helium 4	93
Figure 5.5-2:	Vapour Density of Helium (Ref. /5/)	93
Figure 5.5-3:	Volume Specific Heat Capacity of Liquid He on Saturation Line.....	94
Figure 6.1-1:	CVV Heat Flow Chart for On-Ground Environment	96
Figure 6.1-2:	HTT Temperature Evolution during Ground Autonomy for nominal and sensitivity case	100
Figure 6.1-3:	Thermal Shields Temperature Evolution during Ground Autonomy for 25 mg/s HOT Mass Flow Rate, nominal case	100
Figure 6.2-1:	HTT and HOT Temperature Evolution during Pre-Launch Phase.....	101
Figure 6.2-2:	Thermal Shield Temperature Evolution during Pre-Launch Phase	102

Figure 6.2-3: HOT He Massflow during Pre-Launch Phase 102

Figure 6.2-4: H-EPLM Temperatures during Launch Phase 103

Figure 6.2-5: H-EPLM Temperatures during In-Orbit Cool-Down 104

Figure 6.2-6: Telescope Cool-Down Rate after Decontamination (Cover still closed)..... 105

Figure 6.2-7: HTT Temperature during In-Orbit Cool-Down..... 105

Figure 6.2-8: Helium Mass flow during In-Orbit Cool-Down 105

Figure 6.2-9: Helium Mass Loss during In-Orbit Cool-Down..... 106

Figure 6.3-1: H-EPLM Temperature Distribution for Hot Case Environment at L2 108

Figure 6.3-2: CVV External Heat Flow Chart in [W] (Hot Case)..... 109

Figure 6.3-3: CVV Heat Flow Chart for Hot Case Environment at L2 110

Figure 6.3-4: CVV Heat Flow Chart for Cold Case Environment at L2 110

Figure 6.3-5: HPLM internal Heat Flow Chart for Average Instrument Dissipation and Hot Case Environment at L2..... 111

Figure 6.3-6: Transient Cool-Down of Telescope after S/C Rotation 30° around Y-Axis..... 131

Figure 6.3-7: Transient Cool-Down of LOU Baseplate after S/C Rotation 30° around Y-Axis..... 131

Figure 6.3-8: Transient Cool-Down of CVV after S/C Rotation 30° around Y-Axis..... 132

Figure 6.3-9: Transient Cool-Down of HTT after S/C Rotation 30° around Y-Axis 132

Figure 6.4-1: PACS L0 Interface Temperatures 134

Figure 6.4-2: PACS L0 Interface Heat Flows 134

Figure 6.4-3: PACS L0 Interface Temperatures during Recycling 135

Figure 6.4-4: PACS L0 Interface Heat Flows during Recycling..... 135

Figure 6.4-5: PACS L1 Interface Temperatures 136

Figure 6.4-6: PACS L1 Interface Heat Flows 136

Figure 6.4-7: FPU L2 Interface Temperatures 137

Figure 6.4-8: PACS L2 Interface Heat Flows 137

Figure 6.4-9: SPIRE L0 Interface Temperatures 138

Figure 6.4-10: SPIRE L0 Interface Heat Flows 138

Figure 6.4-11: SPIRE L0 Interface Temperatures during Recycling 139

Figure 6.4-12: SPIRE L0 Interface Heat Flows during Recycling..... 139

Figure 6.4-13: SPIRE Cooler Temperatures during Recycling (for information) 139

Figure 6.4-14: SPIRE L1 Interface Temperatures 140

Figure 6.4-15: SPIRE L1 Interface Heat Flows 140

Figure 6.4-16: SPIRE L3 Interface Temperatures 141

Figure 6.4-17: SPIRE L3 Interface Heat Flows 141

Figure 6.4-18: FPU L2 Interface Temperatures 142

Figure 6.4-19: SPIRE L2 Interface Heat Flows 142

Figure 6.4-20: HIFI L0 Interface Temperature and Stability 143

Figure 6.4-21: HIFI L0 Interface Heat Flow 143

Figure 6.4-22: HIFI L1 Interface Temperature and Stability 144

Figure 6.4-23: HIFI L1 Interface Heat Flow 144

Figure 6.4-24: HIFI L2 Interface Temperature and Stability 145

Figure 6.4-25: HIFI L2 Interface Heat Flow 145

Figure 6.4-26: Total Instrument I/F Heat Load on HTT (different scales on Y-axis) 146

Figure 6.4-27: HTT Temperature and He Mass Flow Rate 147

Figure 6.4-28: Total Instrument I/F Heat Load on L1, L2 and L3 147

Figure 6.4-29: HTT Temperature for Different Conditions 148

Figure 6.4-30: Helium Mass Flow for Different Conditions 148

Figure 6.4-31: PACS L0 Temperature for Different Conditions 149

Figure 6.4-32: PACS L1 Temperature for Different Conditions 149

Figure 6.4-33: SPIRE L0 Temperature for Different Conditions 150

Figure 6.4-34: SPIRE L1 Temperature for Different Conditions 150

Figure 6.4-35: Photometer JFET L3 Temperature for Different Conditions 151

Figure 6.4-36: HIFI L0 Temperature for Different Conditions 151

Figure 6.4-37: HIFI L1 Temperature for Different Conditions 152

Figure 6.4-38: HIFI L2 Temperature for Different Conditions 152

List of Tables

Table 3.1-1:	PACS Temperature Limits	21
Table 3.1-2:	SPIRE Temperature Limits	21
Table 3.1-3:	HIFI Temperature Limits	22
Table 3.1-4:	LOU Temperature Limits.....	23
Table 3.1-5:	Telescope Temperature Limits.....	23
Table 3.2-1:	L2 orbit conditions	26
Table 4.2-1:	Drawings and Submodels used for Thermal Modelling	30
Table 4.3-1:	Item List for Tanks, Spatial Framework and Optical Bench Assembly	35
Table 4.4-1:	Item List for Ventline tubing.....	38
Table 4.5-1:	Item List for PACS.....	45
Table 4.5-2:	Item List for SPIRE.....	49
Table 4.5-3:	Item List for HIFI.....	53
Table 4.6-1:	Item List for Thermal Shields	57
Table 4.7-1:	Item List for CVV and Cryostat Baffle	65
Table 4.8-1:	Item List for LOU and Telescope	70
Table 4.9-1:	Modelling of the CVV Internal Harness Branches in the EPLM TMM.....	71
Table 4.9-2:	CVV Internal SIH Data for PACS, SPIRE and HIFI	73
Table 4.9-3:	CVV External SIH Data	74
Table 4.9-4:	CVV Internal CCH Data	75
Table 4.9-5:	CVV External CCH Data	75
Table 4.10-1:	HSS related Items	78
Table 4.11-1:	SVM/CVV Interface Struts – Numbering and Thermal Design	80
Table 4.11-2:	SVM and SVM Shield related Items.....	82
Table 5.1-1:	Derived MLI Performance Data for Herschel Type MLI	83
Table 5.1-2:	Derived MLI Performance Data for ISO Type MLI /1/.....	83
Table 5.1-3:	Overview on CVV Internal MLI Performance Data	84
Table 5.1-4:	Overview on CVV External MLI Performance Data	85

Table 6.1-1:	Sensitivities for Operation on Ground	97
Table 6.1-2:	Graphical representation of sensitivities for Operation on Ground	98
Table 6.2-1:	Helium loss and HTT temperatures during in-orbit cool down	106
Table 6.3-1:	Analysis Results for Hot and Cold Case Environment.....	107
Table 6.3-2:	In-Orbit Sensitivities for CVV internal elements	114
Table 6.3-3:	In-Orbit Sensitivities for CVV external elements (CVV, SVM TS, Tel., LOU)	115
Table 6.3-4:	In-Orbit Sensitivities for CVV external elements (HSS, SVM TS).....	117
Table 6.3-5:	Graphical representation of In-Orbit Sensitivities for CVV internal elements	118
Table 6.3-6:	Graphical representation of In-Orbit Sensitivities for CVV external elements (CVV, SVM TS, Tel., LOU).....	120
Table 6.3-7:	In-Orbit Sensitivities for Instrument Interface nodes – Level 0	122
Table 6.3-8:	In-Orbit Sensitivities for Instrument Interface nodes – Level 1 & 2.....	123
Table 6.3-9:	In-Orbit Sensitivities for Level 3 Instrument Interface nodes, LOU and Telescope.....	125
Table 6.3-10:	Graphical representation of In-Orbit Sensitivities for Instrument Interface nodes – Level 0	127
Table 6.3-11:	Graphical representation of In-Orbit Sensitivities for Instrument Interface nodes – Level 1 & 2	128
Table 6.3-12:	Graphical representation of In-Orbit Sensitivities for Level 3 Instrument Interface nodes, LOU and Telescope	130
Table 6.6-1:	Specified versus calculated instrument interface temperatures for IID-B allocations	156
Table 6.6-2:	Specified versus calculated instrument interface temperatures for IID-B allocations with increased massflow	157

1 SCOPE

This document describes the HERSCHEL EPLM Detailed Thermal Mathematical Model (DTMM) and Geometrical Mathematical Model (DGMM). It represents the PFM configuration and incorporates the correlation activities performed in the frame of the STM and STM2 test campaigns [RD 45] [RD 46]. The nodal break down and the corresponding assumptions are described in detail. Following the issue numbering of this report, the thermal model is referenced as issue 5 and will be released with the next issue of [RD 47].

Material properties used in the DTMM/DGMM are also reported in this document. Finally, the flight prediction analyses performed with this thermal model are described in detail. The results are shown basically in form of temperature distribution and heat flow charts. A comprehensive sensitivity analysis is performed with respect to lifetime and EPLM temperatures. Instrument interface temperatures are calculated using a dedicated instrument timeline of 6 x 48h which includes transient operation of and switching between 5 different instrument modes. Finally, lifetime calculations are carried out based on the thermal analysis results including transient in-orbit cool down.

2 Applicable and Reference Documents

2.1 Applicable Documents

- AD 01 HERSCHEL/PLANCK Instrument Interface Document IID Part A, Doc. No.: SCI-PT-IIDA-04624, Issue 4, 30.04.2006
- AD 02 HERSCHEL/PLANCK Instrument Interface Document IID Part B for PACS, Doc. No.: SCI-PT-IIDB/PACS-02126, Issue 4, 02.06.2006
- AD 03 HERSCHEL/PLANCK Instrument Interface Document IID Part B for SPIRE, Doc. No.: SCI-PT-IIDB/SPIRE-02124, Issue 4, 01.04.2006
- AD 04 HERSCHEL/PLANCK Instrument Interface Document IID Part B for HIFI, Doc. No.: SCI-PT-IIDB/HIFI-02125, Issue 3.3, 21.10.2005
- AD 05 H-EPLM Environment & Test Requirements Specification, Doc. No.: HP-2-ASED-SP-0004, Issue 3, 16.07.2004
- AD 06 H-EPLM Requirement Specification, Doc. No.: HP-ASPI-SP-0250, Issue 3.3, 20.10.2004
- AD 07 Herschel EPLM Interface Specification; HP-2-ASPI-IS-0039; Issue 6, 07.10.2004
- AD 08 Herschel EPLM Thermal Interfaces; HP-1-ASP-TN-0413; Issue 1, 24.10.2002
- AD 09 List of Acronyms, HP-1-ASPI-LI-0077, Issue 2, 12.07.2004
- AD 10 General Design and Interface Requirements (GDIR), Doc. No.: HP-1-ASPI-SP-0027, Issue 5, 07.10.2004
- AD 11 RFD for HIFI Instrument Interface Temperatures, Doc. No.: HP-2-ASED-RD-0040, Issue 2, 27.07.2006
- AD 12 RFD for Lifetime calculation approach with changed instrument interfaces, Doc. No.: HP-2-ASED-RD-0047, Issue 1, 27.06.2007
- AD 13 Herschel Telescope Specification, Doc. No.: HP-2-ESA-SP-4671 / SCI-PT-RS-04671, Issue 7, 26.07.2004
- AD 14 RFD for Instrument Interface Temperatures, Doc. No.: HP-2-ASED-RD-0020, Issue 1, 26.04.2004
- AD 15 RFW for Photometer JFET dissipation, Doc. No.: HR-SP-RAL-RFW-005 v1

2.2 Reference Documents

- RD 01 Hypothesis and Methods for Lifetime Calculations; Doc.No.: HP-2-ASED-TN-0065, Issue 2, dated 07.04.2004
- RD 02 Harness Inputs for Thermal Analysis Doc.No.: HP-2-ASED-TN-0010, Issue 3.2, dated 21.01.05

- RD 03 Reduced PACS Instrument Interface TMM, Issue 3.1, provided by ESA on 26.04.2007
- RD 04 Reduced SPIRE Instrument Interface TMM, Issue 2.6, provided by SPIRE on 27.04.2007
- RD 05 Reduced HIFI Instrument Interface TMM provided by HIFI on 02.04.2003
- RD 06 He System Description, HP-2-ASED-RP-0034, Issue 3, dated 15.03.2004
- RD 07 Thermal Mathematical Modelling Methods of HPLM Ventline on Optical Bench, HP-2-ASED-TN-0056, Draft Issue, dated 10.06.02
- RD 08 Evaluation of LINDE/ESTEC-MLI Measurements and Transformation to the ISO Cryostat MLI Design, Doc.No.: ISO.TN-B1430.007, dated 12.07.88
- RD 09 J. Doenecke: Survey and Evaluation of Multilayer Insulation Heat Transfer Measurement, ICES July 1993
- RD 10 PACS FPU Drawing No. PACS-KT-ICD-0000W1.22, dated 04.09.01
- RD 11 SPIRE Interface Drawing No. 5264 300, dated 30.07.01
- RD 12 HIFI-FPU External Configuration Drawing No. 455-3-001-0, dated 29.05.01
- RD 13 H-EPLM Pressure Drop Analysis, HP-2-ASED-TN-0071, Issue 1.1, dated 12.03.2004
- RD 14 M. Sander: ISO Thermal Mathematical Model, Submodel VENT, Version 3.00, 24.02.1994
- RD 15 Test Report of the Additional Pressure Drop Measurements of DASA Valve #990-11 at Different Mass Flows and Temperatures, ISO-TR-BCGI0.008, Issue 1, 02.11.1993
- RD 16 SPIRE Cryogenic Interface Thermal Mathematical Model, SPIRE-RAL-PRJ-000728, Issue 2.5, dated 02.02.2004
- RD 17 EPLM Thermal Analysis from Fairing Jettison to Launcher Separation, HP-2-ASED-TN-0096, Issue 1, dated 14.04.2004
- RD 18 Electrical Power Analysis and Design Report, Doc.No.: HP-2-GAMI-AN-0014_F, dated 09.02.06
- RD 19 Helium Content Determination in Orbit, HP-2-ASED-AN-0010, Issue 1.1, dated 06.12.04
- RD 20 TSS Design Justification, HP-2-ASED-TN-0081, dated 12.05.2003
- RD 21 Procurement Specification for Tank Support Suspensions, HP-2-ASED-PS-0017, Issue 2, dated 25.03.03
- RD 22 Procurement Specification for Herschel Spatial Framework, HP-2-ASED-PS-0016, Issue 2.1, dated 14.02.03
- RD 23 OBA Specification, HP-2-ASED-PS-0015, Issue 2.1, dated 15.03.04
- RD 24 Procurement Specification for H-PLM Internal MLI, HP-2-ASED-PS-0028, Issue 2, dated 07.03.03
- RD 25 Procurement Specification for Herschel Support Structures, HP-2-ASED-PS-0026, Issue 2, dated 19.11.03
- RD 26 Procurement Specification for SVM Thermal Shield, HP-2-ASED-PS-0034, Issue 2, dated 01.12.03

- RD 27 Procurement Specification for Herschel Telescope Mounting Structure, HP-2-ASED-PS-0037 Issue 3, dated 14.07.05
- RD 28 Procurement Specification for Herschel External MLI, HP-2-ASED-PS-0029, Issue 1, dated 29.07.02
- RD 29 Reduced Telescope TMM/GMM, Issue 2.1, provided by ESA on 15.05.2007
- RD 30 Thermal Shields Procurement Specification PFM, HP-2-ASED-PS-0044, Issue 1, dated 04.11.02
- RD 31 Procurement Specification for Herschel Cryostat Vacuum Vessel, HP-2-ASED-PS-0003, Issue 4, dated 09.10.02
- RD 32 Procurement Specification for Cryostat Cover, Cryostat Baffle and Test Components, HP-2-ASED-PS-0018, Issue 3, dated 02.12.03
- RD 33 HIFI LOU Cryoharness - Electrical/Thermal Performance, HP-2-ASED-FX-0553-03, dated 27.06.03
- RD 34 RYMSA CDR Data Package
- RD 35 Evaluation of Thermal Property Tests for the H-EPLM TMM, HP-2-ASED-RP-0095, Issue 2, dated 21.06.2006
- RD 36 Evaluation of Calorimeter Tests for Herschel Internal MLI; HP-2-ASED-TN-0083, Issue 1, dated 01.03.2004
- RD 37 HSS Thermal Analysis Report, HP-2-DSSA-AN-0013, Issue 6, 31.05.2007
- RD 38 Strut Fitting Design Update, HP-ASED-FX-0037-04, dated 28.01.2004
- RD 39 HP-2-AAE-AN-0004 Issue 2.1, dated 29.01.2004
- RD 40 LEOP HTT Temperature Margins and Verification, HP-ASED-FX-0226-04, dated 31.03.2004
- RD 41 Herschel Planck Visit at French Guiana Launch Site, HP-1-AEA-MN-0003
- RD 42 E-mail TAS-F "H-P-ASP-LT-9388 H Tel FQR Al#50 1st part close-out - Harness dissipation during decontamination", 20.07.2007
- RD 43 Barbecue Thermal Analyses, Doc. No.: HP-2-ASED-TN-0112, Issue 1, 07.02.2005
- RD 44 SVM Thermal Shield Thermal Analyses, Doc. No.: HP-2-ASED-TN-0119, Issue 1, 25.04.2005
- RD 45 H-EPLM TMM Correlation of STM TB/TV Test, Doc. No.: HP-2-ASED-RP-0176, Issue 1, 23.03.2007
- RD 46 H-PLM TMM Correlation of Delta STM TB/TV Test, Doc. No.: HP-2-ASED-RP-0230, Issue 1, 12.06.2007
- RD 47 H-EPLM Thermal Model Release, Doc. No.: HP-2-ASED-RP-0207, Issue 4, 03.05.2007
- RD 48 TMM Correlation for L0 Conductance Measurements, Doc. No.: HP-2-ASED-TN-0138, Issue 1.1, 27.07.2007
- RD 49 TMM Correlation for L1 and L3 Performance Measurements, Doc. No.: HP-2-ASED-TN-0147, Issue 1, 27.07.2007

- RD 50 Herschel PLM MLI, Design Report External MLI, Doc. No.: HP-2-AAEM-RP-0007, Issue 3, 29.08.2005
- RD 51 HERSCHEL I/F DRAWING PLM/SVM INTERFACE STRUTS, Doc. No.: HP-2-ECAS-ID-0002, Issue 3, 31.01.2005
- RD 52 RFD for PACS FPU Interface Temperatures, Doc. No.: HP-2-ASED-RD-0048, Issue 1.1, 23.07.2007
- RD 53 RFD for SPIRE FPU Interface Temperatures, Doc. No.: HP-2-ASED-RD-0050, Issue 1.1, 23.07.2007
- RD 54 Herschel Telescope Flight thermal predictions, Doc. No.: HER.NT.0750.T.ASTR, Issue 3, 19.06.2006
- RD 55 Thermal analyses of baffles on Thermal shields one and two, Doc. No.: HP-2-ASP-TN-1161, Issue 1, 09.06.2006
- RD 56 Herschel – HST, HTT Thermal Link, Doc. No.: HP-2-AIRT-TN-0002, Issue 1, 23.11.2004
- RD 57 Assessment of Coax Cable Modelling Refinement and Thermal Anchoring, Doc. No.: HP-2-ASED-TN-0136, Issue 2, 12.07.2006
- RD 58 STM TB/TV TMM Meeting, Doc. No.: HP-2-ASED-MN-0958, 12.05.2005

Note: Further References concerning material properties are listed in section 5.6 separately.

2.3 Abbreviations

ASED	Astrium GmbH
ASP	Alcatel Space
HSS	Herschel Solar Array & Sunshade
OBA	Optical Bench Assembly
OBP	Optical Bench Plate
SIH	Scientific Harness
SS	Summer Solstice
SSD	Sunshade
TSS	Tank Support Suspensions
TAS-F	Thales Alenia Space France
WS	Winter Solstice

Further Abbreviations are listed in AD 09.

3 Requirements and Boundary Conditions

3.1 Thermal Requirements

3.1.1 Lifetime

The relevant requirements regarding the H-EPLM lifetime are as follows:

GDGE-210 [AD 10]:

For the Herschel mission, the spacecraft shall have a nominal lifetime of 3.5 years. This duration is counted from the launch to end of mission. This duration includes an allocation of 6 months for the transfer to the L-2 Lissajous orbit. (SPER-005)

HERS-0530 [AD 06]:

A cryogenic lifetime of 3.5 years shall be achieved. This requirement shall be met including dispersions. Computation of the cryogenic lifetime shall be as defined in Annex 1 of [AD06].

HERS-0535 [AD 06]:

The lifetime computation shall take into account a total conductive heat load of 200 mW via the 6 interface points of the Star Tracker Assembly.

HERS-0540 [AD 06]:

The determination on a half-yearly basis (7 measurements over nominal lifetime) of the remaining mass of helium contained in the main tank over the nominal lifetime shall be included in the lifetime calculation and shall not shorten the lifetime by more than 1%.

HERS-2250 [AD 06]:

The cryostat shall allow for an on-ground autonomy period of 6 days with the helium tank filled and the helium temperature after 6 days below 2.1 K and instruments being non operational.

For the in-orbit lifetime prediction, it has been agreed between ESA, TAS-F and ASER to replace the formerly used IID-A allocations by IID-B conditions, i.e. to perform the calculations with implemented instrument TMMs [RD 03] [RD 04] [RD 05]. Instrument dissipations meanwhile have been verified in unit level tests, so the IID-B values are considered more realistic than the IID-A allocations. An RFD has been raised against HERS-0530 to formalise this approach [AD 12]. The instruments are operated in average dissipation mode, and an average thermal environment at L2 orbit is used to calculate the average massflow. The corresponding external heat loads are given in Table 3.2-1.

3.1.2 Temperature Requirements of Instruments within Cryostat

The temperature limits required at the instrument interfaces are specified in the instrument interface control documents IIDs for PACS [AD 02], SPIRE [AD 03] and HIFI [AD 04] and are compiled in Table 3.1-1 to Table 3.1-3 together with the corresponding interface nodes.

Instrument Interface	Temp. Level	TMM Node	Operating		Heat Load [mW]	Non-operating	
			Min. [K]	Max. [K]		Min.	Max.
PACS							
Red Detector	L0	724	1.6	1.75	1.0	NA	60°C *) 85°C **)
Blue Detector	L0	723	1.6	2.0	2.2	NA	60°C *) 85°C **)
Cooler Pump	L0	761	1.6	10 5	500 (peak) 2.2	NA	60°C *) 85°C **)
Cooler Evaporator	L0	762	1.6	1.85	15.1	NA	60°C *) 85°C **)
Optics/Structure assy.	L1	781 782 783	2.0	5.0	30	NA	60°C *) 85°C **)
OBA Interface	L2	371	NA	12	0	NA	NA

*) Continuous temperature limit

***) Short-duration temperature limit for bake-out during a maximum of 3 days at 80°C

Table 3.1-1: PACS Temperature Limits

Instrument Interface	Temp. Level	TMM Node	Operating		Heat Load [mW]	Non-operating	
			Min. [K]	Max. [K]		Min.	Max.
SPIRE							
Detector Enclosure	L0	814	0	2.0 1.71 (goal)	4.0 1.0 (goal)	NA	60°C *
Cooler Pump	L0	815	0	10 2	500 (peak) 2	NA	
Cooler Evaporator	L0	816	0	1.85 1.75 (goal)	15 15 (goal)	NA	
SPIRE OBA units	L1	800 830	0	5.5 3.7 (goal)	15 13 (goal)	NA	
OBA Interface	L2	381		12 8 (goal)	0 0 (goal)	NA	80°C **
Instrument Shield	L2	315		16	0	NA	80°C **
PM-JFETs	L3	831	0	15	50	NA	80°C **
SM-JFET	L3	832	0	15	25	NA	

*) Continuous temperature limit, but compliant with bake-out temperature of 80°C for 72 h maximum

***) Bake-out temperature for 72 h maximum

Table 3.1-2: SPIRE Temperature Limits

Instrument Interface	Temp. Level	TMM Node	Operating		Heat Load [mW]	Non-operating	
			Min. [K]	Max. [K]		Min.	Max.
L0 boundary	L0	949	0	2.1 **	6.8	0 K	60°C *
L1 boundary	L1	939	0	6.4 **	15.5	0 K	60°C *
FPU structure	L2	919	0	20	22	0 K	60°C *

*) Continuous temperature limit, but compliant with the bake-out of 3 days at 80°C

**) Value acc. RFD [AD 11]; L0 was 2.0 K, L1 was 6.0 K before

Table 3.1-3: HIFI Temperature Limits

Temperature Stability for HIFI as specified in AD 04

The following temperature changes shall not be exceeded during operation under the assumption of passive thermal control and with the exception of heat peaks caused by HIFI:

Level 2 parts: 0.015 K per 100 s

Level 1 parts: 0.006 K per 100 s

Level 0 parts: 0.006 K per 100 s

3.1.3 Temperature Requirements for LOU (outside Cryostat)

As specified in AD 04 the HIFI Local Oscillator Unit (LOU) shall not exceed the temperature limits at the mounting interfaces compiled in following Table 3.1-4.

Instrument Interface	Thermal node No.	Operating		Functional testing	Start-up	Switch-off	Non-operating	
		Min. [K]	Max. [K]	Max. [K]	[K]	[K]	Min. [K]	Max. [K]
LOU	4201	90	150	298	80	303	80	328

Table 3.1-4: LOU Temperature Limits

3.1.4 Temperature Requirements for Telescope

For the HERSCHEL Telescope, the following requirements exist [AD 13]:

	Thermal node No.	Operating		Contamination Release (3 weeks)		Non-operating	
		Min. [K]	Max. [K]	Min. [K]	Max. [K]	Min. [K]	Max. [K]
Telescope	8001	70	90	313	323	55	358

Table 3.1-5: Telescope Temperature Limits

3.1.5 Thermal Interface Requirements for SVM

According to HEIF-TH-225 a [AD 7], the maximum thermal flux from HSS to SVM shall be less than 15 W distributed as follows:

- maximum 5 W via HSS CFRP struts, uniformly distributed on each interface point,
- maximum 10 W via Sunshield brackets, uniformly distributed on each interface point.

3.2 Thermal Environment

3.2.1 Ground and Pre-Launch Phase

According to R-EVT-040 [AD 05], the He filled PLM is in a temperature controlled environment at $22\pm 3^{\circ}\text{C}$ during ground operation.

During transport and storage, different environments apply, ranging from 10°C to 30°C at ambient pressure ranging from 970 mbar to 1070 mbar.

3.2.2 Early Orbit Phase

The thermal loads to be applied for the H-EPLM during the launch and early orbit phase are defined in detail in [AD 05].

Solar constant:

The applicable values of the solar constant for the early orbit phase (BOL) are:

- 1425 W/m^2 during Winter Solstice (WS)
- 1325 W/m^2 during Summer Solstice (SS)

The solar aspect angle evolution during launch is shown in Figure 3.2-1 [AD 13] [RD 43] [RD 44].

Albedo is the fraction of incident solar radiation that is reflected from the earth back into space. A value of 0.3 ± 0.05 shall be used.

Earth Infrared Thermal Radiation

The Earth infrared radiation shall be assumed as a black body with a characteristic temperature of 288 K. The average infrared radiation emitted by Earth is 230 W/m^2 , with variations between 150 W/m^2 and 350 W/m^2 .

From the above mentioned data, following load cases can be derived:

Hot Case: WS solar constant, max. Earth IR radiation, 0.35 albedo
BOL thermo-optical properties, Solar power generator in shunt mode

Cold Case: SS solar constant, min. Earth IR radiation, 0.25 albedo
BOL thermo-optical properties, Solar power generator in operating mode

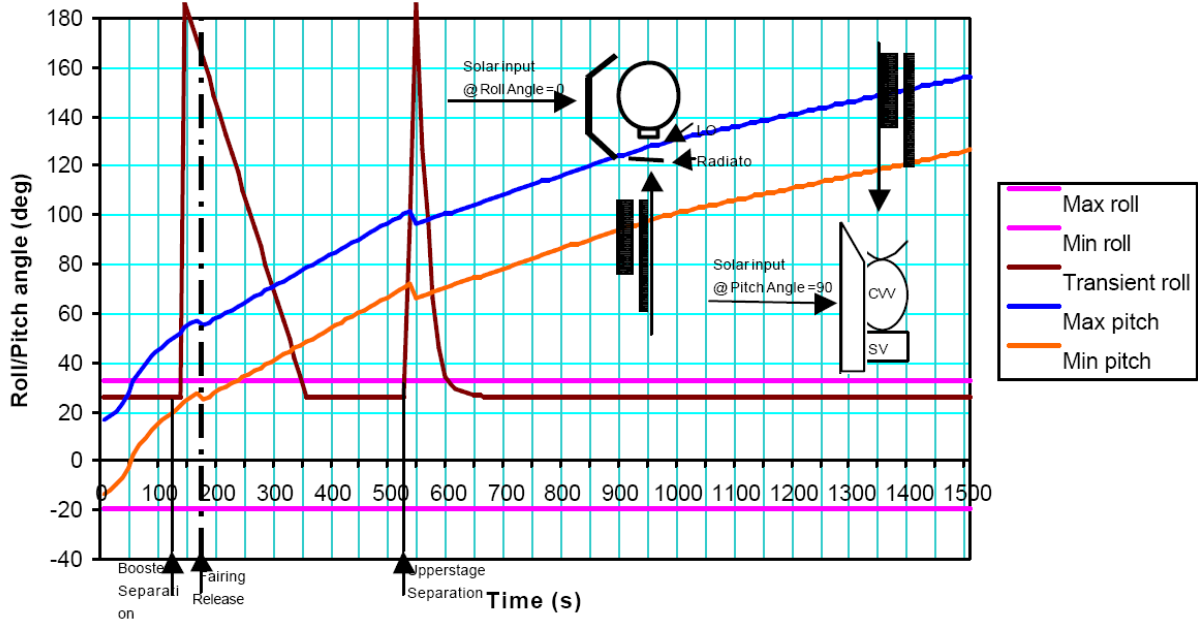

Figure 3.2-1: Roll and Pitch Angle Evolution During Launch

3.2.3 Operation Phase in L2 Orbit

During in-orbit operation at L2 the extremes of solar constant are (section 3.4.3 of [AD 05]):

- 1405 W/m² during Winter Solstice (WS)
- 1287 W/m² during Summer Solstice (SS)

During HERSCHEL mission phases and operational modes, the solar aspect angle will be maintained at ± 30 deg around the Y-axis and at ± 1 deg around the X-axis (HERS-0090 a [AD 06]).

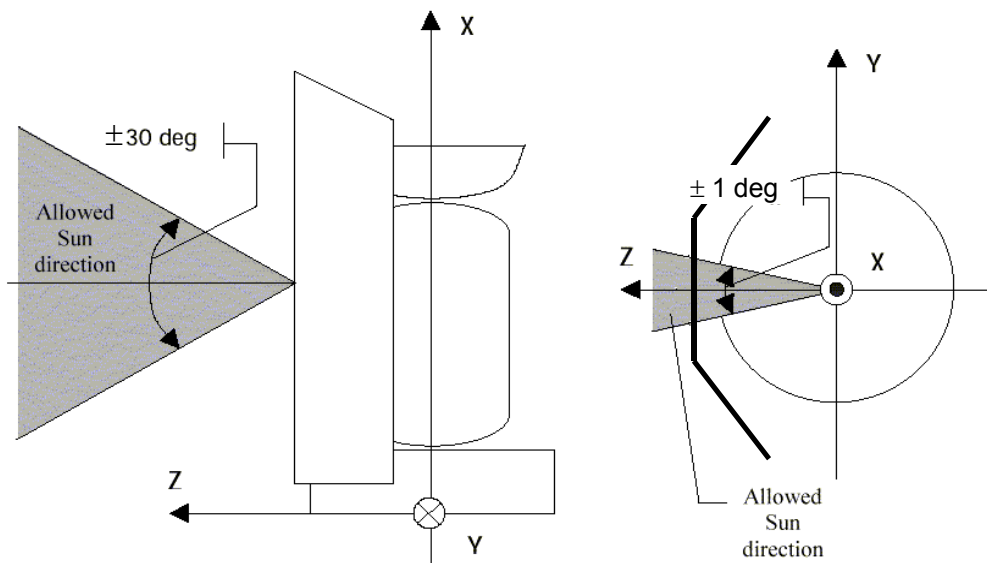

Figure 3.2-2: Solar Aspect Angles on H-EPLM at L2

From the above-mentioned data, the load cases compiled in Table 3.2-1 are derived (extracted from [RD 01]).

	Solar constant	Solar aspect angle SAA, around Y axis	OSR Solar absorptance	SVM I/F for CVV struts	SVM I/F for WG, SIH, CCH, HSS struts, SVM Thermal Shield struts
Cold case	1287 W/m ² (SS)	30°	0.1 (BOL)	293 K	266 K
Hot case	1405 W/m ² (WS)	0°	0.2 (EOL)	293 K	293 K
Average case	1352 W/m ²	17.267°	0.15	293 K	280 K

Table 3.2-1: L2 orbit conditions

The temperatures of the H-EPLM structure attachment points on the SVM (conductive I/F, see also Table 3.2-1) and the temperatures of the SVM outer surfaces like top panel MLI (radiative I/F) are considered according to [AD 07] and [AD 08].

The average case is the basis for the lifetime calculation (see section 6.5), more details to that case are given in [RD 01].

4 Thermal Model Description

4.1 Software and Handling

The H-EPLM is written in ESATAN format V 8.9.2, the geometry model is written in ESARAD format V 5.6.3.

The following main calculation modes can be operated from ESATAN (input file control.ctl, control variable GPLTO):

- G Operation on Ground (steady state)
- P Prelaunch: Launch Autonomy (SUBCASE=2), including pre-cooling and HOT refill (former On-Ground Autonomy operated via SUBCASE=1 considered to be covered by Launch Autonomy, therefore deleted)
- L Launch until fairing jettisoning
- T In-orbit transient cool down with telescope decontamination heating
- O Operation at L2 orbit, including nominal steady state modes (hot, cold), transient orbit timeline, safe mode and a lifetime calculation mode (adjustable via control variables SUBCASE, IMODE, TRANS)

The instrument test mode on ground (formerly operated via "X") forms no longer part of this thermal report. If required, related calculations for the IST will be performed and documented separately.

With this STM2 correlated TMM, different sets of sensitivity parameters concerning internal MLI performance have been compiled for orbit and ground conditions (outcome of [RD 46]). For orbit, the parameters k_1, k_2a, k_2b and k_2c are set to 1.6 (tanks and shields MLI). For ground, k_2b (TS2 MLI) is set to 1.1.

ESARAD also provides some case dependent control now (to be adjusted in input file CONTROL.CTL, control variable LCASE):

- 0 All orbit cases
- 1 All ground cases, including Launch Autonomy, Launch and Transfer/LEOP

By calling one of these cases the corresponding thermo-optical properties and geometrical configurations are automatically loaded.

4.2 EPLM Configuration Breakdown for Thermal Modelling

Thermal Report	TMM Issue 3 HP-2-ASED-RP-0011, Issue 3.0, dated 09.09.03	TMM Issue 4 HP-2-ASED-RP-0011, Issue 4.0, dated April 04	TMM Issue 5 HP-2-ASED-RP-0011, Issue 5.0, dated August 07
Thermal Mathematical Model	TMM (ESATAN): herschel.d, Issue 3, dated 12.05.2003. GMM (ESARAD): HERSCHEL_EOL.erg, Issue 3, dated 12.05.03	TMM (ESATAN): herschel.d, Issue 4, dated 19.03.2004. GMM (ESARAD): HERSCHEL_EOL.erg, Issue 4, dated 19.03.04	TMM (ESATAN): herschel.d, Issue 5, dated. GMM (ESARAD): HERSCHEL.erg, Issue 5, dated
HTT	Herschel HTT Interface Drawing: HP-2-ASED-ID-0001, Issue D, dated 08.08.03	Herschel HTT Interface Drawing: HP-2-ASED-ID-0001, Issue D, dated 08.08.03	Herschel HTT Interface Drawing: HP-2-ASED-ID-0001, Issue D, dated 08.08.03
HOT	Herschel HOT Interface Drawing: HP-2-ASED-ID-0002, Issue C, dated 06.08.03	Herschel HOT Interface Drawing: HP-2-ASED-ID-0002, Issue C, dated 06.08.03	Herschel HOT Interface Drawing: HP-2-ASED-ID-0002, Issue C, dated 06.08.03
OBP including Instrument Shield	Optical Bench Assembly Interface drawing HP-2-ASED-ID-0042, Issue A, dated 31.03.03	Optical Bench Assembly Interface drawing HP-2-ASED-ID-0042, Issue A, dated 31.03.03	Optical Bench Assembly Interface drawing HP-2-ASED-ID-0042, Issue A, dated 31.03.03
L0, L1, L3 Thermal Links and Ventline	L0 Conductance Values acc. to OBA Specification, HP-2-ASED-PS-0015, Issue 1.3, dated 17.01.03	AIRL Thermal Analysis HP-2-AIRL-AN-0003, Issue 4, dated 13.02.04 and HP-2-AIRL-HO-0010, dated 05.02.04	AIRL Thermal Analysis HP-2-AIRL-AN-0003, Issue 4, dated 13.02.04 and HP-2-AIRL-HO-0010, dated 05.02.04
PACS	Reduced PACS Instrument TMM provided by PACS on 09.05.2003. ASED made GMM acc. to PACS FPU Drawing No. PACS-KT-ICD-0000W1.22, dated 04.09.01. (IR emissivity of FPU set to 0.26)	Reduced PACS Instrument TMM provided by PACS on 09.05.2003. ASED made GMM acc. to PACS FPU Drawing No. PACS-KT-ICD-0000W1.22, dated 04.09.01. (IR emissivity of FPU set to 0.26)	Reduced PACS Instrument TMM Iss. 3.1 provided by ESA on 26.04.2007. ASED made GMM acc. to PACS FPU Drawing No. PACS-KT-ICD-0000W1.22, dated 04.09.01. (IR emissivity of FPU set to 0.26)
SPIRE	Reduced SPIRE Instrument TMM, Issue 2.3 provided by SPIRE on 28.03.2003. SPIRE RGMM provided by SPIRE on 20.01.03, Issue 2 (IR emissivity of FPU: 0.2)	Reduced SPIRE Instrument TMM, Issue 2.5 provided by SPIRE on 03.02.2004. SPIRE RGMM provided by SPIRE on 03.02.04, Issue 3 (IR emissivity of FPU: 0.2)	Reduced SPIRE Instrument TMM, Issue 2.6 provided by SPIRE on 28.04.2007. SPIRE RGMM provided by SPIRE on 03.02.04, Issue 3 (IR emissivity of FPU STM2 correlated value: 0.05)
HIFI	Reduced HIFI Instrument	Reduced HIFI Instrument	Reduced HIFI Instrument TMM

Thermal Report	TMM Issue 3 HP-2-ASED-RP-0011, Issue 3.0, dated 09.09.03	TMM Issue 4 HP-2-ASED-RP-0011, Issue 4.0, dated April 04	TMM Issue 5 HP-2-ASED-RP-0011, Issue 5.0, dated August 07
	TMM provided by HIFI on 28.03.2003. ASED made GMM acc. to HIFI-FPU External Configuration Drawing No. 455-3-001-0, dated 29.05.01 (IR emissivity of FPU set to 0.26)	TMM provided by HIFI on 28.03.2003. ASED made GMM acc. to HIFI-FPU External Configuration Drawing No. 455-3-001-0, dated 29.05.01 (IR emissivity of FPU set to 0.26)	provided by HIFI on 28.03.2003. ASED made GMM acc. to HIFI-FPU External Configuration Drawing No. 455-3-001-0, dated 29.05.01 (IR emissivity of FPU set to 0.26)
Thermal Shields with TS2 Baffle and LOU Baffle	Geometry as Issue 2.1	Thermal Shield Geometry as Issue 2.1, Baffles acc. to. HP-2-ASED-ID-0065, dated Jan 04	Thermal Shield Geometry as Issue 4; TS2 Baffle acc. to. HP-2-ASED-ID-0065 Iss. B, 30.09.04; LOU int. Baffles acc. to HP-2-ASP-TN-1161, iss. 1, 09.06.06
TSS	Dimensions acc. to HP-2-ASED-TN-0081, dated 12.05.2003	Dimensions acc. to HP-2-ASED-TN-0081, dated 12.05.2003	Dimensions acc. to HP-2-ASED-TN-0081, dated 12.05.2003
Cryostat Baffle and Beam Entrance	Drawing No.: HP-2-ASED-ID-0063-01-0A, dated 31.01.03.	Drawing No.: HP-2-ASED-ID-0063, dated 31.01.03 and HP-2-ASED-ID-0095, dated 25.07.03	Drawing No.: HP-2-ASED-ID-0063-0C, 30.09.04 and HP-2-ASED-ID-0095, dated 25.07.03
Cryo Cover	Drawing No.: HP-2-ASED-ID-0063-01-0A, dated 31.01.03.	HP-2-AAE-IC-0001, Issue 3, dated 18.10.03	HP-2-AAE-IC-0001, Issue 5, 20.01.05
CVV including Radiators	Herschel Overall Dimensions, HP-2-ASED-ID-0009, Issue B, dated 08.07.03	Herschel CVV Radiator Assembly, HP-2-APCO-DW-0015-01-0A	Herschel CVV Radiator Assembly, HP-2-APCO-DW-0015-01-0A
LOU	as Issue 2.1	Thermal Analysis Handout from ABAQUS, dated 28.01.04	Thermal Analysis Handout from ABAQUS, dated 28.01.04
Telescope	ASED made GMM acc. to ASEF catia model DT0018251-02-00-3D-TELESCOPE-28-05-02.model. (IR emissivity of M1 set to 0.01, RD29)	ASED made GMM acc. to ASEF catia model DT0018251-02-00-3D-TELESCOPE-28-05-02.model. (IR emissivity of M1 set to 0.01, RD29)	Reduced TMM/GMM Iss. 2.1 provided by ESA on 15.05.07
Harness	LOU harness: RD 33 HIFI Coax: Precision Tube JS50141 and JN50141 other harness as Issue 2.1	Harness Inputs for Thermal Analysis Doc.No.: HP-2-ASED-TN-0010, Issue 3.1, dated 12.03.04	Harness Inputs for Thermal Analysis Doc.No.: HP-2-ASED-TN-0010, Issue 3.2, 21.01.05 HIFI Coax: HP-2-ASED-PS-0048 iss. 3, 18.10.06
Sunshade Panels	Sunshade Panels I/F drawing HP-2-ASED-ID-0051, Issue B,	Sunshade Panels I/F drawing HP-2-ASED-ID-0051, Issue B,	HP-2-DSSA-ID-0004_E, 13.01.06; HP-2-DSSA-DD-

Thermal Report	TMM Issue 3	TMM Issue 4	TMM Issue 5
	HP-2-ASED-RP-0011, Issue 3.0, dated 09.09.03	HP-2-ASED-RP-0011, Issue 4.0, dated April 04	HP-2-ASED-RP-0011, Issue 5.0, dated August 07
	dated 17.03.03	dated 17.03.03	
Solar Array Panels	Solar Array Panels I/F drawing HP-2-ASED-ID-0043, Issue B, dated 17.03.03	Solar Array Panels I/F drawing HP-2-ASED-ID-0043, Issue B, dated 17.03.03	0002, iss. 1, Nov. 05
EPLM Support Structures	ASED reference design	HP-2-ECAS-AN-0004, Issue 2, dated 28.11.03 and Fax HP-ASED-FX-0037-04, 28.01.04	HP-2-ECAS-AN-0004, Issue 6, 27.07.05 and HP-2-ECAS-ID-0002, Issue 3, 31.01.05
SVM Thermal Shield	Drawing No.: HP-2-ASED-ID-0056-01-0A, not yet released	Drawing No.: HP-2-ASED-ID-0056, Issue A, dated 14.10.03	Drawing No.: HP-2-ECAS-DW-0006, 27.07.04
SVM	SVM Submodel provided by ASPI on 24.10.02, HP-2-ASP-TN-0413; Issue 1	SVM Submodel provided by ASPI on 24.10.02, HP-2-ASP-TN-0413; Issue 1	SVM Submodel provided by ASPI on 24.10.02, HP-2-ASP-TN-0413; Issue 1

Table 4.2-1: Drawings and Submodels used for Thermal Modelling

4.3 Optical Bench Assembly, Spatial Framework and Tanks

The Optical Bench Assembly (OBA) is mounted on top of the HTT via the so-called Spatial Framework (SFW). The SFW consists of a frame made of aluminium and struts to the HTT made out of T300 CFRP. The OBA is connected to the aluminium frame by means of Titanium blades. The SFW itself is attached to the CVV structure by the tank suspension straps. The nodal break down of the SFW is shown in Figure 4.3-1 and Figure 4.3-2. Concerning the tank MLIs see also Figure 4.6-2.

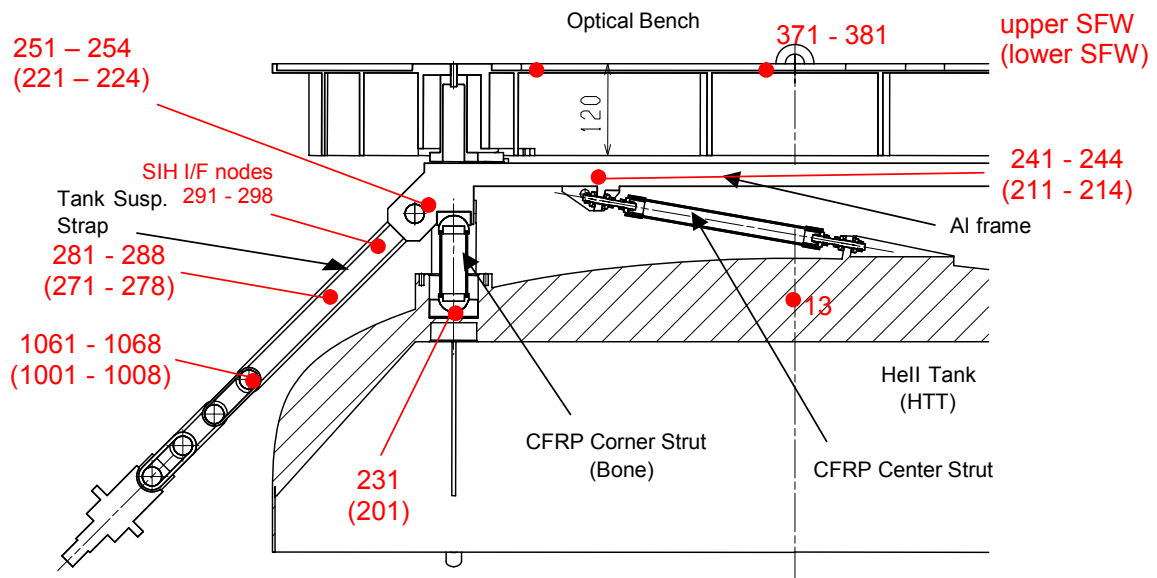

Figure 4.3-1: Nodal Breakdown of HTT and SFW

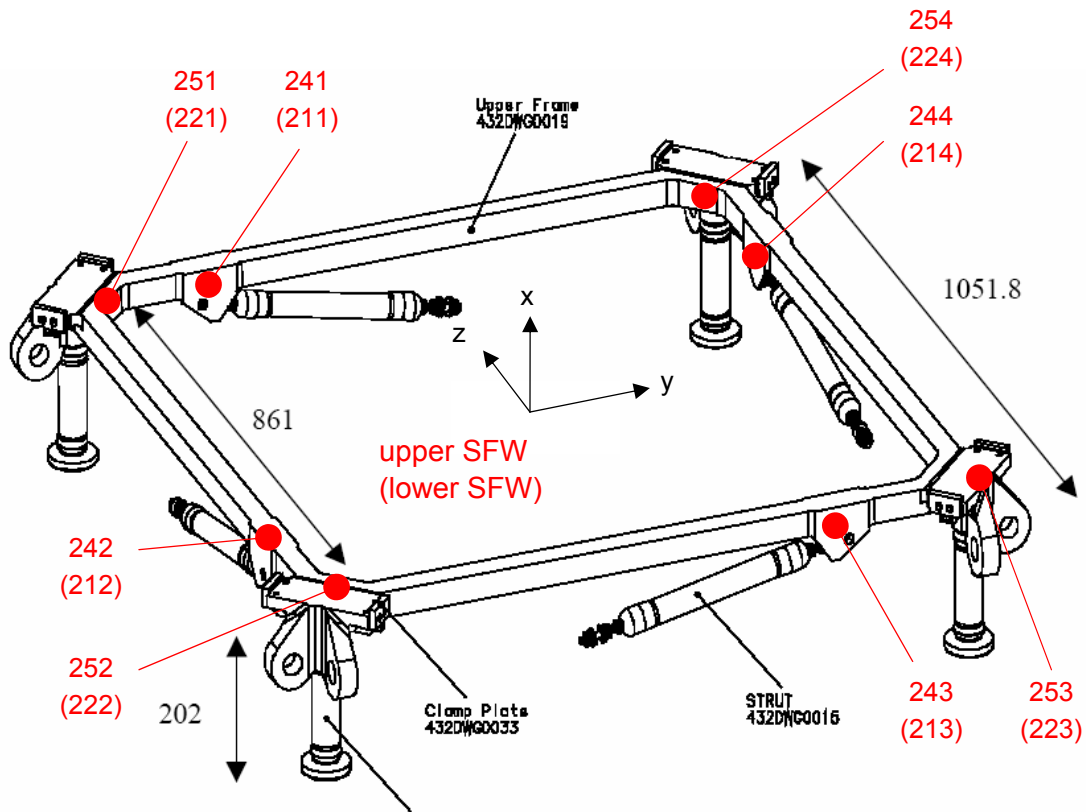

Figure 4.3-2: Nodal Breakdown of Spatial Framework (detailed)

The OBA with the instruments is covered with the Instrument Shield, see Figure 4.3-3. The opening for the beam entrance is modelled with cylindrical baffles, thermally (and mechanically) attached to the Thermal Shield 2 (node 2050) and to the Instrument Shield (node 315). The thermal and material properties are compiled in Table 4.3-1. The Instrument Shield baffle has rectangular cut-outs reflecting the beam pattern for the three instruments, see Figure 4.3-4.

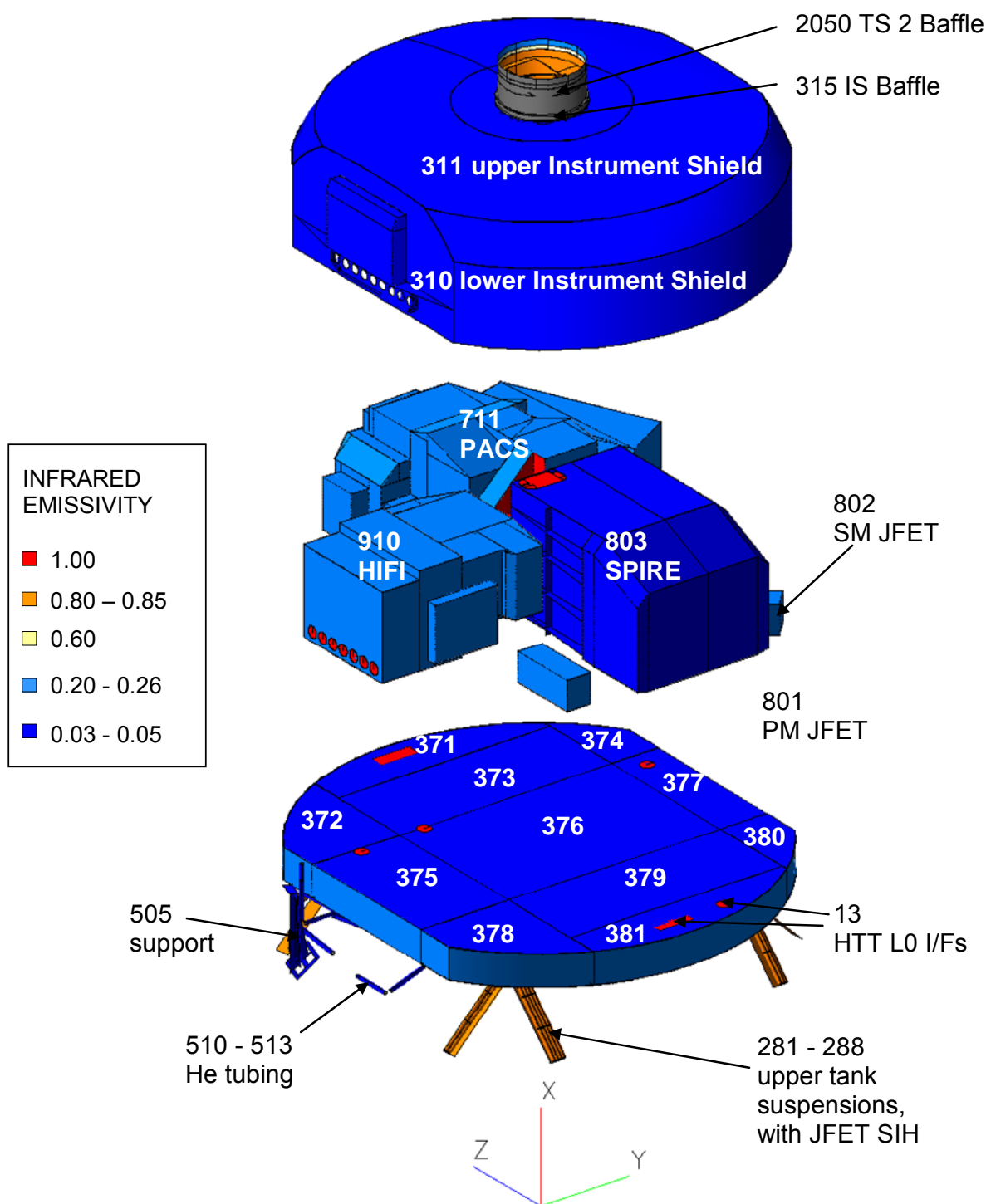

Figure 4.3-3: Nodal Breakdown of Optical Bench with Instruments

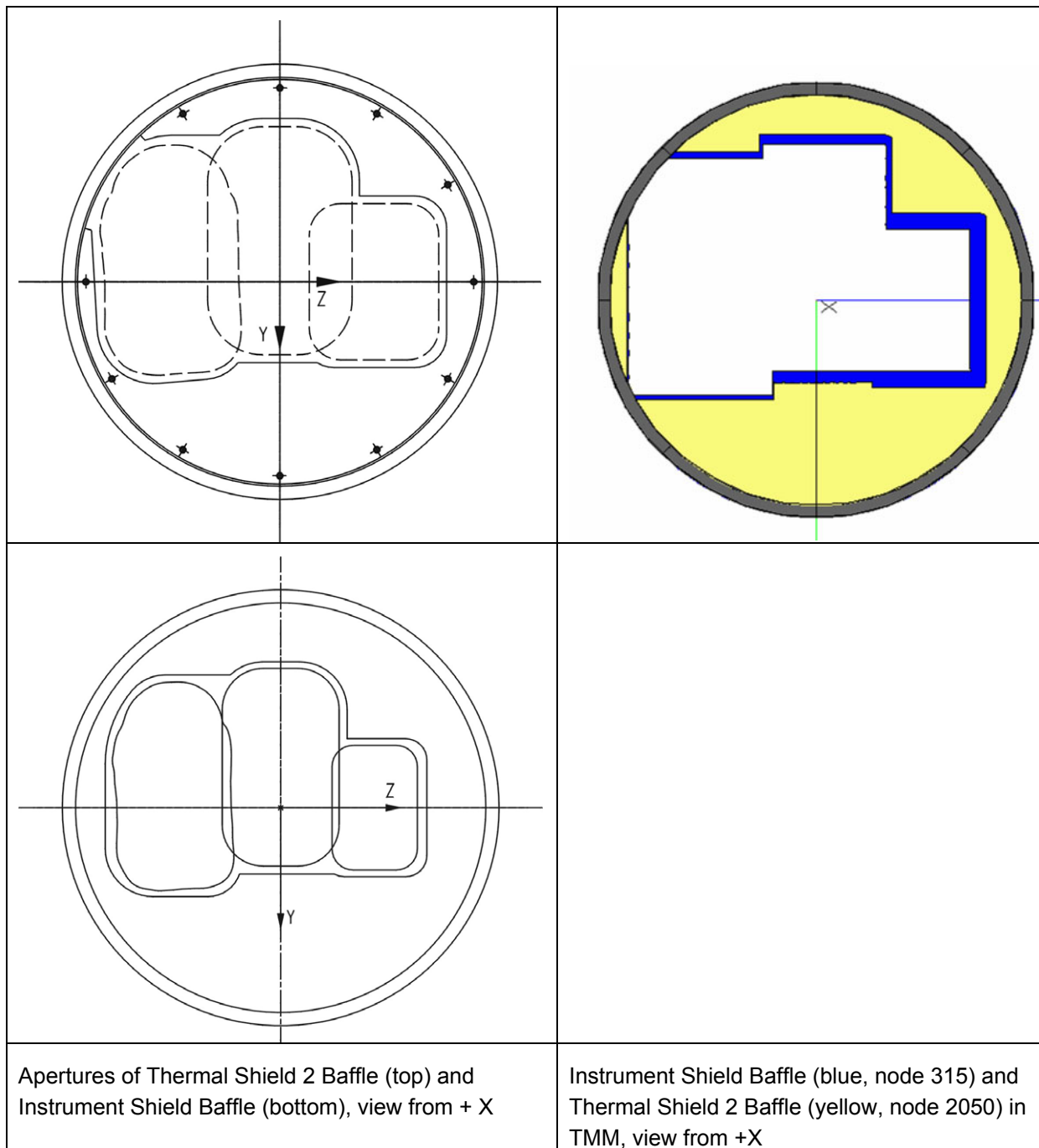

Figure 4.3-4: Beam Pattern for the Three Instruments

Item	Node	Material / Components	Mass	Size	IR Emiss.	Unit Level Requirement	Remark
He II Tank (HTT)	10, 13	superfluid Helium (He II) Al tank (Al 5083, 3.3547)	337 kg 141.8 kg	2367 l (cold volume) D = 1.63 m, h = 1.352 m			
MLI on He II Tank low cyl. upp.	111 112 113	10 layers	1.1 kg 3.2 kg 1.1 kg	A = 3.26 m ² A = 2.91 m ² (D=1.63 m, h=0.569 m) A = 2.94 m ²	0.05	R-INM-0220 [RD 24] R-INM-0230 [RD 24]	
He I Tank (HOT)	20	90% He I (=~8.7 kg He on ground) ellipsoid shaped Al tank (Al 5083)	19 kg	78 l (cold volume) D = 0.88 m, h = 0.252 m			
MLI on He I Tank low upp.	121 122	10 layers	0.45 kg 0.45 kg	A = 0.66 m ² A = 0.66 m ²	0.05	R-INM-0320 [RD 24] R-INM-0330 [RD 24]	
Lower Spatial Framework (ISF)	211-214	Al frame (Al 5083) Center struts T300 to HTT SST blades to HOT	19.6 kg	A/L = 4 x 0.736 mm A/L = 4 x 0.968 mm		R-SFW-300 [RD 22]	
	221-224	Corner struts T300 to HTT		A/L = 4 x 2.825 mm		R-SFW-290 [RD 22]	
Upper Spatial Framework (uSF)	241-244	Al frame (Al 5083) Center struts T300	16.3 kg	A/L = 4 x 0.736 mm		R-SFW-300 [RD 22]	
	251-254	Corner struts T300		A/L = 4 x 2.825 mm		R-SFW-290 [RD 22]	
Optical Bench Plate (OBP)	371-381	Aluminium structure 4 Titanium blades to Al frame of uSF	60 kg	D=1.63 m, H=70 mm, 2.5 mm skins Total A/L = 28.6 mm Ti6AlV4	0.1 +x side 0.2 others	R-OBA-330 [RD 23] R-OBA-145 [RD 23]	
Instrument Shield	310	Al 6061 (cylinder)	3.7 kg	A = 1.70 m ² , s = 0.8 mm	0.03 all faces	R-OBA-326 [RD 23]	
	311	Al 1100 (top)	4.7 kg	A = 2.18 m ² , s = 0.8 mm		R-OBA-325 [RD 23]	
Instrument Shield Baffle	315	Al baffle with aperture; cut-out area 0.035 m ² , see Figure 4.3-4	0.23 kg	D = 307 mm, s = 0.8 mm	0.03 all faces	R-OBA-410 [RD 23]	

Table 4.3-1: Item List for Tanks, Spatial Framework and Optical Bench Assembly

4.4 Helium Ventline Subsystem

4.4.1 Modelling of Ventline

A schematic overview of the OBA and Thermal Shield ventline modelling is given in following Figure 4.4-1.

Detail (out of next page):

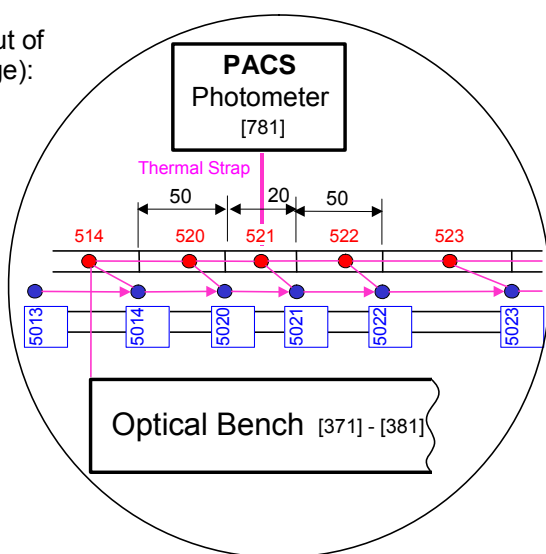

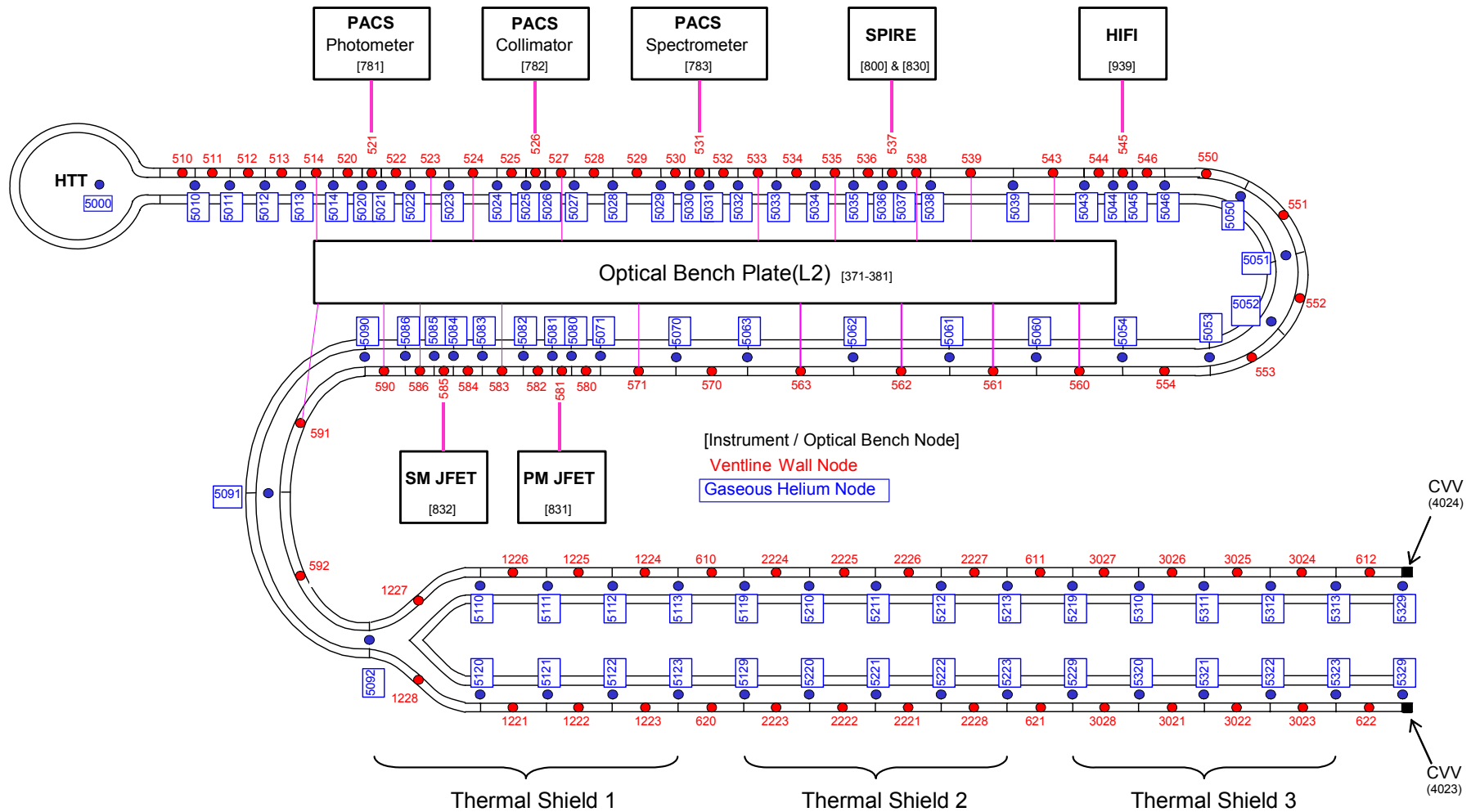

Figure 4.4-1: Nodal Break Down of OB Ventline and Thermal Shield Ventline

Item	Node	Material / Components	Mass	Size	IR Emiss.	Unit Level Requirement	Remark
GHe Ventline between HTT and Level 1	510-514 505	stainless steel tube Ventline support L1 inlet, stainless steel	0.41 kg 0.70 kg	A=19.6 mm ² ; D=13 mm, d=12 mm	0.05 0.05		
GHe Ventline Level 1	520-546	Al6063 tube CFRP T300 brackets to OBP	0.67 kg	A = 112.3 mm ² ; D=14.9 mm, d=12 mm, incl. fins Total A/I = 2.016 mm		R-OBA-360 [RD 23]	
GHe Ventline between Level 1 and Level 2	550-554	Al6061 tube (not coupled to OBP)	0.03 kg	A = 44.6 mm ² ; D=12.7 mm, d=10.2 mm		R-OBA-365 [RD 23]	
GHe Ventline Level 2	560-563	Al tube on OBP strongly bolted to OBP	0.63 kg	A = 112.3 mm ² ; D=14.9 mm, d=12 mm, incl. fins		R-OBA-370 [RD 23]	
GHe Ventline between Level 2 and Level 3	570-571	Al6061 tube (not coupled to OBP)	0.03 kg	A = 44.6 mm ² ; D=12.7 mm, d=10.2 mm		R-OBA-365 [RD 23]	
GHe Ventline Level 3	580-586	Al6063 tube CFRP T300 brackets to OBP	0.12 kg	A=61.3 mm ² ; D=14.9 mm, d=12 mm Total A/I = 9.90 mm			
GHe Ventline between Level 3 and TS1	590-592	stainless steel tube	0.15 kg	A=17.3 mm ² ; D=12.7 mm, d=11.8 mm			
GHe Ventline between Thermal Shields/CVV	610-612 620-622	stainless steel tube	1.2 kg	A=17.3 mm ² ; D=12.7 mm, d=11.8 mm			
Filling Port	440-445	stainless steel	2.08 kg	ISO design	0.1		
MLI on Filling Port	643-644	towards FP inner end, 10 layers			0.05	R-INM-0820 [RD 24]	
Safety line	451-459 455	SST; GHe conduction considered Cu strap thermal link to TS 1 (1036)	0.29 kg	A=27.5 mm ² ; D=18 mm, d=17 mm A = 1.7 mm ² , l = 480 mm	0.1 0.05 in SLI		RD 56
Filling line	471-499	SST; GHe conduction considered	0.48 kg	A=11.8 mm ² ; D=8 mm, d=7 mm			
HTT tubing	431-435 461-463	SST; GHe conduction considered	0.68 kg	A=19.6 mm ² ; D=13 mm, d=12 mm			
HOT tubing	411-417 421-424 417	SST; GHe conduction considered V701 inlet: Cu strap to ISF	0.54 kg	A=15.7 mm ² ; D=10 mm, d=9 mm A=11.8 mm ² ; D=8 mm, d=7 mm A = 0.354 mm ² , l = 65 mm			
Valves	400-408	SST	15.0 kg				

Table 4.4-1: Item List for Ventline tubing

Radiation within filling/safety lines:

To assess the impact of radiation from the CVV interface down the Filling Port and the safety line to the SV123 that is mounted on the HTT a separat small ESARAD model has been established with the following basic assumptions:

- The filling line is invisible from the CVV interface due to the filter and the Joule-Thompson valve in the Filling Port. The filling line is therefore neglected in this model. The FP is closed at the location of the JT valve.
- A straight safety line with the correct length is assumed (conservative wrt bent tube).
- The emissivity of the CVV interface is assumed to be 0.7, the emissivity of the SV123 internal parts is assumed to be 0.9. These assumptions are considered to be conservative.
- The end of the safety line is directly coupled to the HTT, i.e. the heat flow resistance through the SV123 is neglected.
- For the emissivity of the internal surface of the FP and the safety line, a value of 0.05 is assumed. The reflectivity is considered to be 100% specular.

The following picture shows modelling of the Filling Port and the Safety Line in the assessment model.

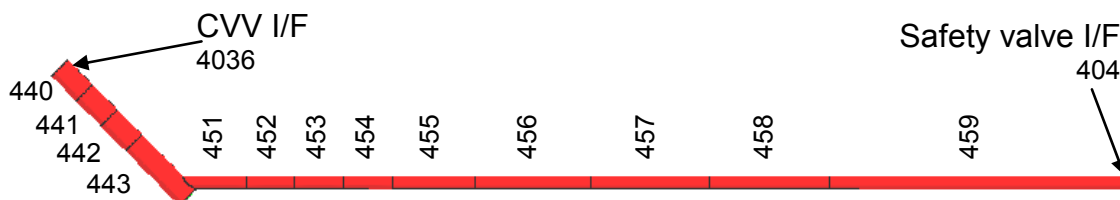

The calculated radiative couplings are implemented in the Herschel TMM.

4.4.2 Pressure Drop Model

The pressure drop calculation within the ESATAN model uses the detailed numerical pressure drop model as described in [RD 13].

The detailed pressure drop model is based on the pressure drop model used in the ISO TMM [RD 14] for the final flight predictions. In the detailed model, the pressure drop of the individual vent line components (e.g. PPS, straight pipes, bends, t-pieces, valves, heater, nozzles...) is calculated by dedicated subroutines. Most of these subroutines are directly inherited from the ISO model, with the exceptions being

1. PPS: The Herschel phase separator is different from the ISO PPS. A mini-model-type regression function is used to represent the flight model porous plug which was characterised as Sample 5 in the Herschel PPS Pre-Development test campaign. The regression formula is

$$p_{in}^2 - p_{out}^2 = a \cdot \dot{m}^b \cdot T^c$$

with pressure p [mbar], mass flow rate \dot{m} [mg/s], temperature T [K], and fit parameters

a=6.039899454, b=1.532479916, and c=0.439538736.

2. Electromagnetic valves: The original valve function from ISO results in unrealistically small pressure drop values (below 10^{-10} Pa per valve) for the Herschel conditions. The function has therefore been replaced by a mini-model type regression which represents the measurements of the external valves (without filters) carried out in the ISO programme [RD 15]. Filters in the external valves are implemented by calling a dedicated filter function. The impedance coefficient of this function is adjusted to the measurements performed with the Herschel TM valve and filters.
3. CVSE Pump: For the nominal ground steady-state case, a cryo vacuum pump is attached to the V502. The characteristic of this pump is represented by a newly introduced function which calculates the inlet pressure depending on the mass flow rate and the gas temperature. This feature is currently not being used within the TMM.

The pressure drop model is called from ESATAN with the following arguments:

CALL CALCMD (TIMEM, MDOT, T10, T546, T563, T586, T1031, T2031, T3031, T5344, IPPS, INOZZ, SUCCES)

This call calculates the mass flow rates depending on the tank temperature and the temperature distribution along the ventline. Input arguments are

- TIMEM: current time step, used for control output
- MDOT: initial value for mass flow rate calculation, new value after calcmd returns
- T10-T5344: temperatures of the individual elements
- IPPS: integer switch: =1 for flow through PPS, =0 for bypass via V104, <0 for closed HTT
- INOZZ: integer switch: =1 for flow through small nozzles, =2 flow through big and small nozzles, <= 0 for flow via V502
- SUCCESS: integer flag: =0 if iteration was successful (calcmd output)

To calculate the tank temperature depending on a given mass flow rate and temperature distribution along the vent line, the pressure drop model is called with the subroutine

CALL CALCTT (TIMEM, MDOT, T10, T546, T563, T586, T1031, T2031, T3031, T5344, IPPS, INOZZ, SUCCES). This subroutine uses the same arguments as for the mass flow calculation routine calcmd.

CALCMD and CALCTT both call the internal subroutine DPVENT and apply the Regula Falsi to iterate the mass flow rate until the pressure drop along the vent line, together with the nozzle inlet pressure calculated from the choked flow conditions, is equal to the pressure in the tank as defined by the tank temperature (or vice versa for CALCTT). The subroutine DPVENT calculates and sums up the respective pressure drop contributions of the individual vent line components one by one going upstream from the external nozzles to the phase separator. Bends in the pipe routing are modelled using equal or smaller bending radii than defined in the drawings. For the two pairs of parallel redundant valves V103/V106 and V501/V503, it is assumed that the respective valve with the shorter pipe routing does not open. Filling and safety lines as well as the filling port are not represented in the current version of the pressure drop model.

The Fortran code for CALCMD, CALCTT, and all functions and routines which are used internally by the pressure drop model is included in the file calcmd.f, which has to be compiled and transformed to an object library named USRLIB.a. The makefile delivered with the TMM automatically performs these

tasks. The Esatan pre-processor requires that the calling names of the subroutines provided in the object library be listed in the file USRLIB.DAT.

The detailed pressure drop model is completely coded in Fortran 77. Thus it can be used either as a stand-alone program with the temperatures of the vent line sections being defined as input, or it can be called from the ESATAN Herschel TMM to perform transient analyses with variable mass flow rate.

The dominating contributions to the overall pressure drop in the orbit cool-down and operation phases are generated by the PPS and the external nozzles. The nozzle throat diameters are adjusted for the combination of desired tank temperature, temperature distribution along the vent line and mass flow rate, and are hard-coded in the pressure drop model. Changes with an impact on the mass flow rate or temperatures will therefore also have an impact on the average tank temperature. The nozzle diameters used in the current version are 1.27 mm for two small and 4.5 mm for one big nozzle. With these settings and the calculated mass flow rates, a nominal HTT temperature of 1.659 K for orbit hot case with average instrument dissipation and a maximum mass flow rate below 20 mg/s (as required by the PPS) during the in-orbit cool-down are achieved.

The flow factors determined from unit level test have to be implemented in the pressure drop model in order to be able to predict the vent line behaviour after a modification of the nozzle hardware and dedicated unit level tests. At the same time, an additional iteration loop to determine the mass flow distribution between large and small nozzles shall be avoided to minimize the impact on computational effort.

The pressure drop elements of the nozzles and valves have different mass flow and temperature dependencies. An Excel calculation is used to determine the inlet pressure at V504, and the mass flow through the small and large nozzles for temperatures from 60 to 300 K and mass flows from 2 to 60 mg/s. This calculation is based on the individual nozzle flow factors determined by test. In a second step, an effective nozzle flow factor α_{eff} for a single nozzle with 4.5 mm diameter (large nozzle as-built) is calculated that results in the same overall mass flow. A fit function is used to implement the mass flow and temperature dependence:

$$\alpha_{eff} = a + b \cdot \dot{m}^d + c \cdot T^e$$

with the fit coefficients a, b, c, d, e determined to give a least squares fit:

$$a = -1.9195$$

$$b = 3.7088$$

$$c = -0.7561$$

$$d = 0.0186$$

$$e = 0.0392$$

Detailed information on the calculation fundamentals for each vent line component as well as representative results are given in [RD 13].

4.5 Instruments

The latest issues of the Instrument Interface Thermal Mathematical Models (ITMMs) have been supplied by the instrument people [RD 04] [RD 05] resp. ESA [RD 03] in ESATAN format and are implemented as submodels in the overall H-EPLM TMM structure. SPIRE in addition has delivered an Interface Geometrical Mathematical Model (IGMM) in ESARAD format. Since no IGMMs of PACS and HIFI were available, they had to be established by ASED according to the corresponding FPU drawings in [RD 10] and [RD 12]. The IGMMs are implemented as submodels in the overall H-EPLM GMM.

4.5.1 PACS

The PACS instrument TMM thermal network is illustrated in Figure 4.5-1. The relevant data of each instrument node are compiled in Table 4.5-1 together with the design data of the thermal links to the Level 0 and Level 1 interfaces. The dissipation timeline during PACS operation and sorption cooler recycling is shown in Figure 4.5-2 and Figure 4.5-3.

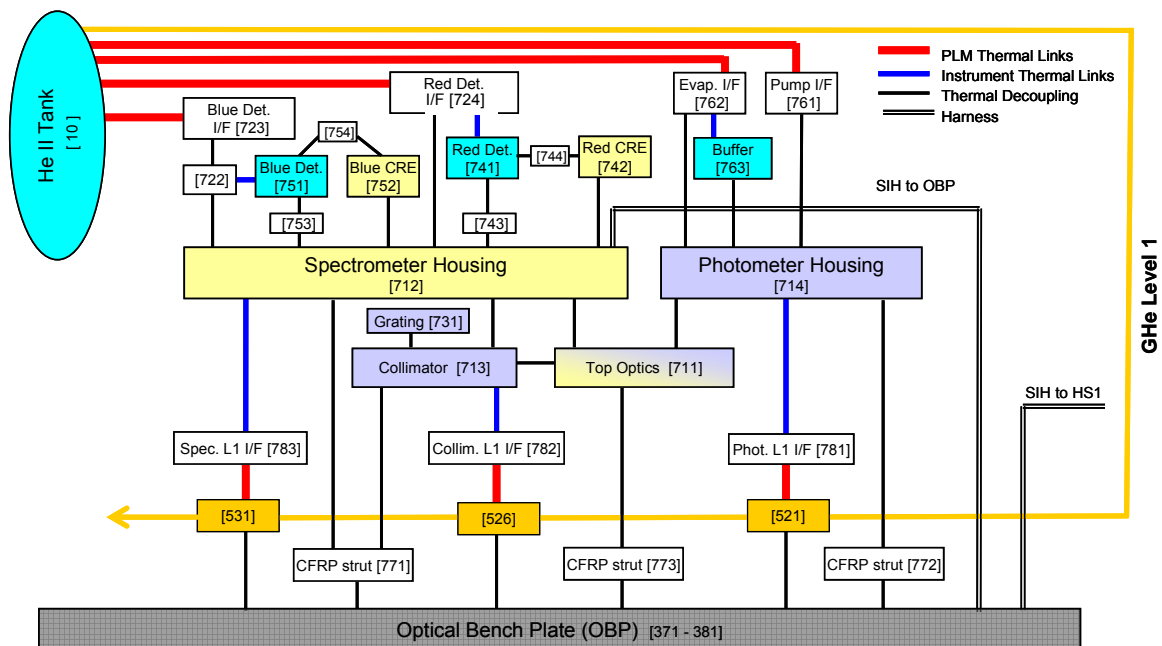

Figure 4.5-1: Reduced PACS Instrument TMM

Note that with this latest issue of the PACS TMM the PLM L0 Thermal Links are reduced to the AI pods (and related contact conductances), compare to Table 4.5-1. The flexible Cu links are provided by PACS and therefore form part of the PACS TMM.

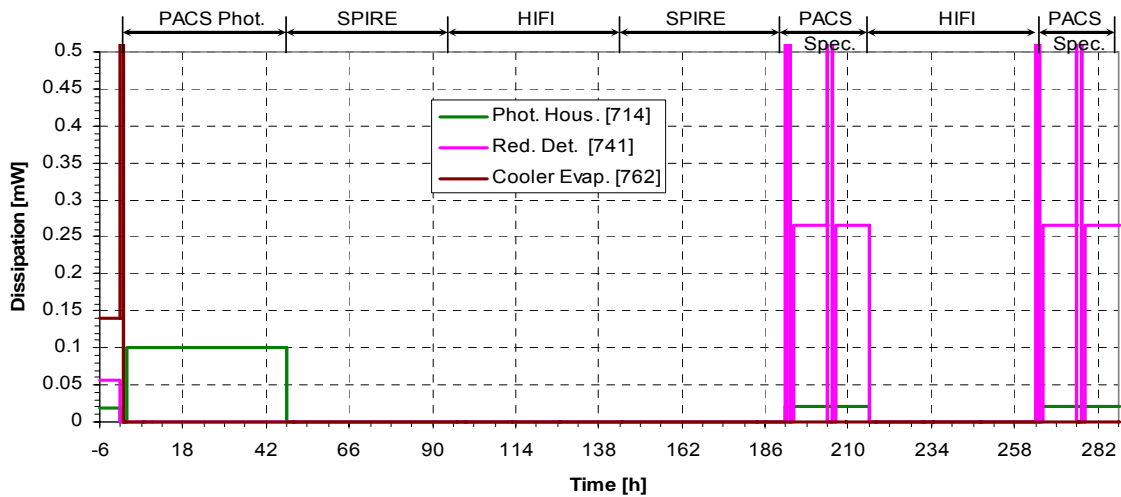
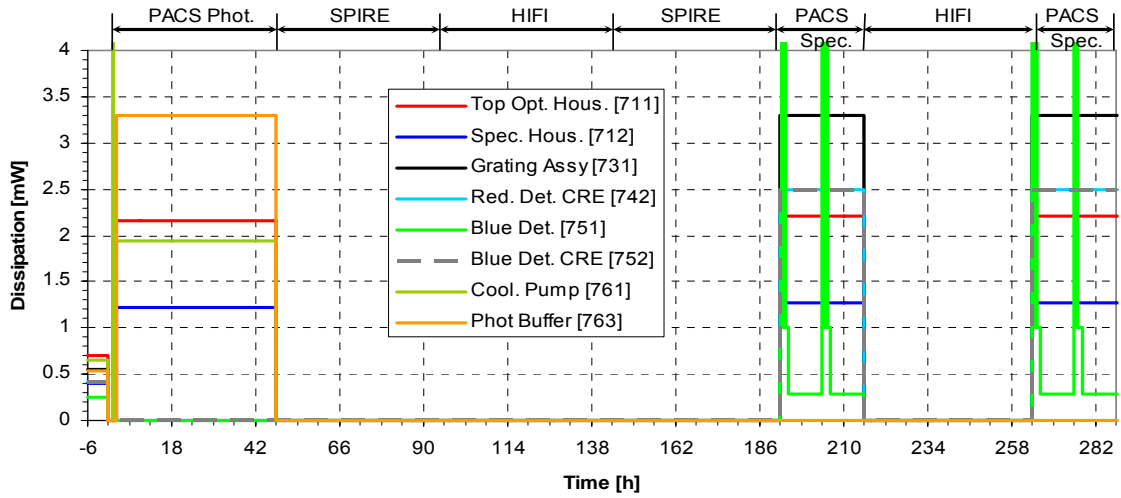

Figure 4.5-2: PACS Dissipation Profile during Operation

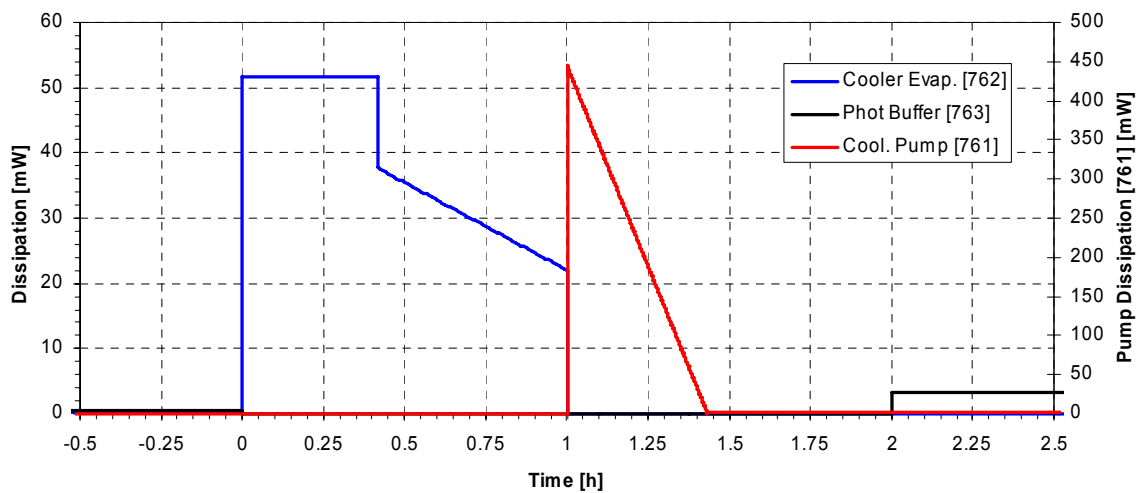

Figure 4.5-3: PACS Dissipation Profile during Recycling

Item	Node	Material / Components	Mass [kg]	Size / Performance	IR Emiss.	Unit Level Requirement	Remark
Red Detector I/F	724	Thermal link to HTT (L0) Al 1050 pod		4 x M4 cross sect.: 452 mm ² , l=0.284m 8 x M5 at HTT I/F		R-OBA-345 [RD 23]	
Feed Through Red Det.	721						
Feed Through Blue Det.	722						
Blue Detector I/F	723	Thermal link to HTT (L0) Al 1050 pod		4 x M4 cross sect.: 580 mm ² , l=0.235m 8 x M5 at HTT I/F		R-OBA-345 [RD 23]	
Cooler Pump I/F	761	Thermal link to HTT (L0) Al 1050 pod	0.15	4 x M4 cross sect.: 1130 mm ² , l=0.235m 8 x M5 at HTT I/F		R-OBA-345 [RD 23]	
Evaporator I/F	762	Thermal link to HTT (L0) Al 1050 pod	0.15	4 x M4 cross sect.: 1130 mm ² , l=0.235m 8 x M5 at HTT I/F		R-OBA-345 [RD 23]	
Buffer	763	Al, PACS cooling strap to Evaporator I/F	1.45				
Blue Detector	751	Al	2.9				
Red Detector	741	Al	2.25				
Blue Det. CRE	752	Al	0.4				
Red Det. CRE	742	Al	0.4				
CFRP strut Blue Det.	753						
CFRP strut Red Det.	743						
Harness Blue Det. Int.	754						
Harness Red Det. Int.	744						
Spectr. Housing	712	Al	14.9				harness I/F
Collimator Housing	713	Al	13.7				
Phot. Housing	714	Al, Ti	15.2				
Top Optics	711	Al	14.5	Apertures with filters: 0.002 m ²	0.26 1.0		

Item	Node	Material / Components	Mass [kg]	Size / Performance	IR Emiss.	Unit Level Requirement	Remark
Grating	731	Al, Cu	4.0				
Phot. L1 I/F	781	Cu Cooling strap to GHe ventline (L1) Cu flexible strap		2 x M4 at Instr. I/F cross sect.: (20x3)mm, l=0.217m 4 x M4 at ventline I/F		R-OBA-345 [RD 23]	
Collimator L1 I/F	782	Cu Cooling strap to GHe ventline (L1) Cu flexible strap		2 x M4 at Instr. I/F cross sect.: (20x2)mm, l=0.128m 4 x M4 at ventline I/F		R-OBA-345 [RD 23]	
Spec. L1 I/F	783	Cu Cooling strap to GHe ventline (L1) Cu flexible strap		2 x M4 at Instr. I/F cross sect.: (20x3)mm, l=0.227m 4 x M4 at ventline I/F		R-OBA-345 [RD 23]	
L2 I/F (Phot.)	772	CFRP bracket to OBP (L2)		A/L= 7.66 mm			
L2 I/F (Top Opt.)	773	CFRP bracket to OBP (L2)		A/L= 15.3 mm			
L2 I/F (Spec/Coll.)	771	CFRP bracket to OBP (L2)		A/L= 23.0 mm			

Table 4.5-1: Item List for PACS

4.5.2 SPIRE

The SPIRE instrument TMM thermal network is illustrated in Figure 4.5-4. All thermal nodes are represented in this sketch and are also compiled in Table 4.5-2, together with the design and performance data of the thermal links to the Level 0, Level 1 and Level 3 interfaces. The dissipation timeline during SPIRE operation and sorption cooler recycling is shown in Figure 4.5-5 and Figure 4.5-6, respectively. A more detailed description of the SPIRE instrument TMM is given in RD 16.

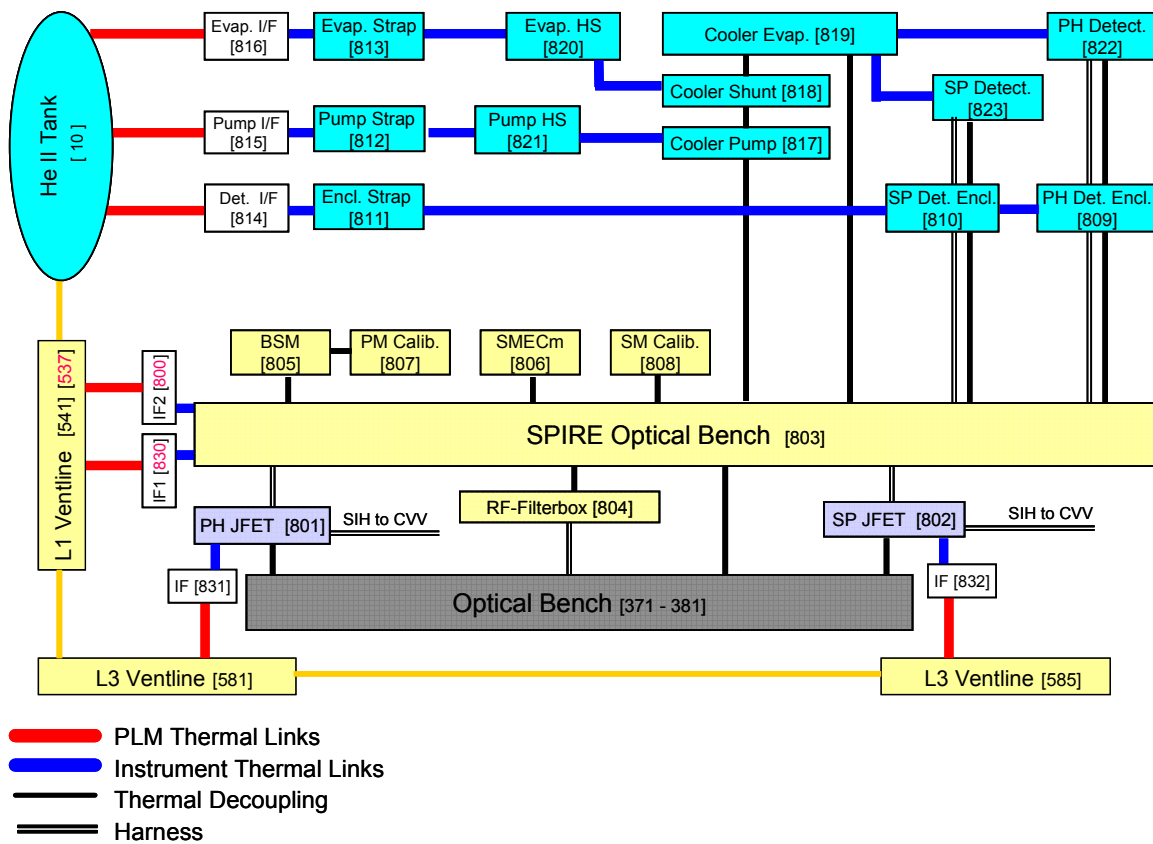

Figure 4.5-4: Reduced SPIRE Instrument TMM

The following radiative couplings (GR) inside the SPIRE TMM exist:

$$GR (819,820) = 6.619E-5 \text{ m}^2$$

$$GR (817,821) = 6.619E-5 \text{ m}^2.$$

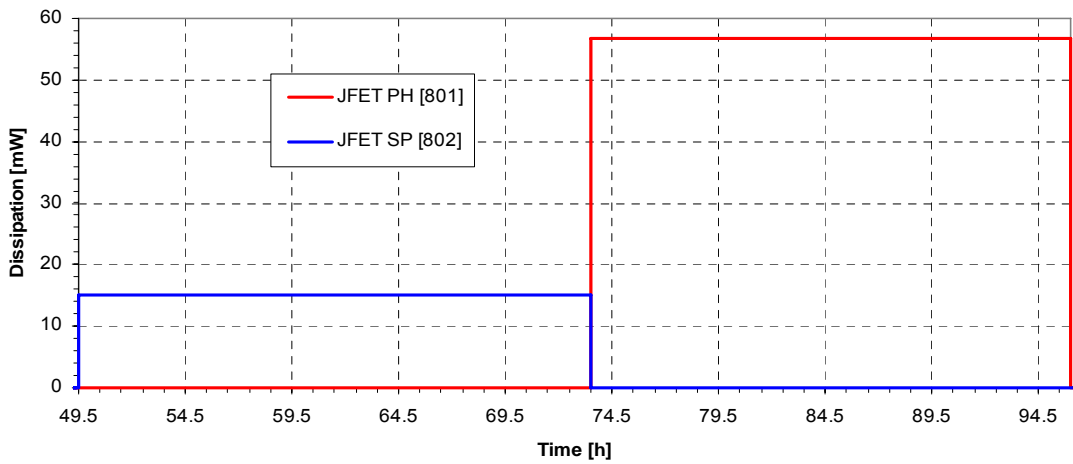
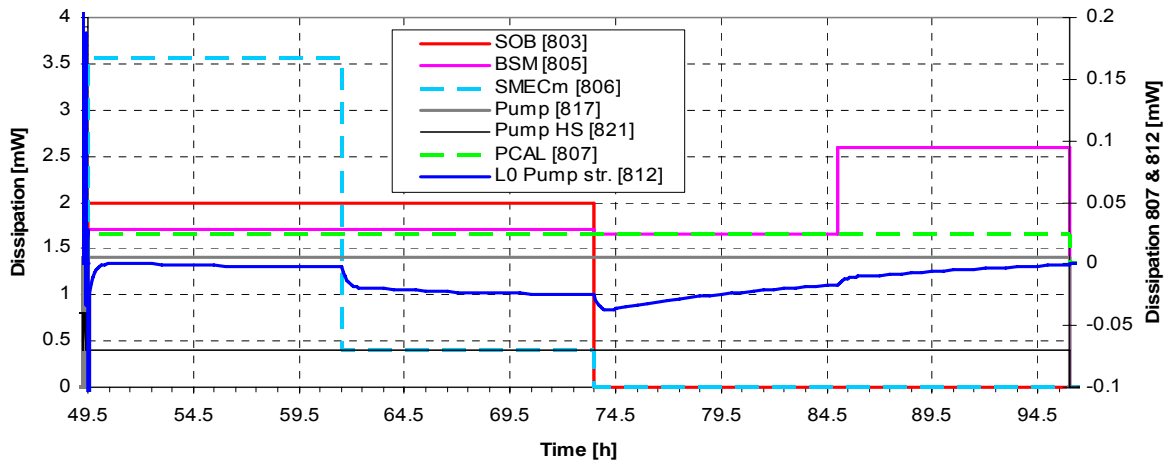

Figure 4.5-5: SPIRE Dissipation Profile during Operation

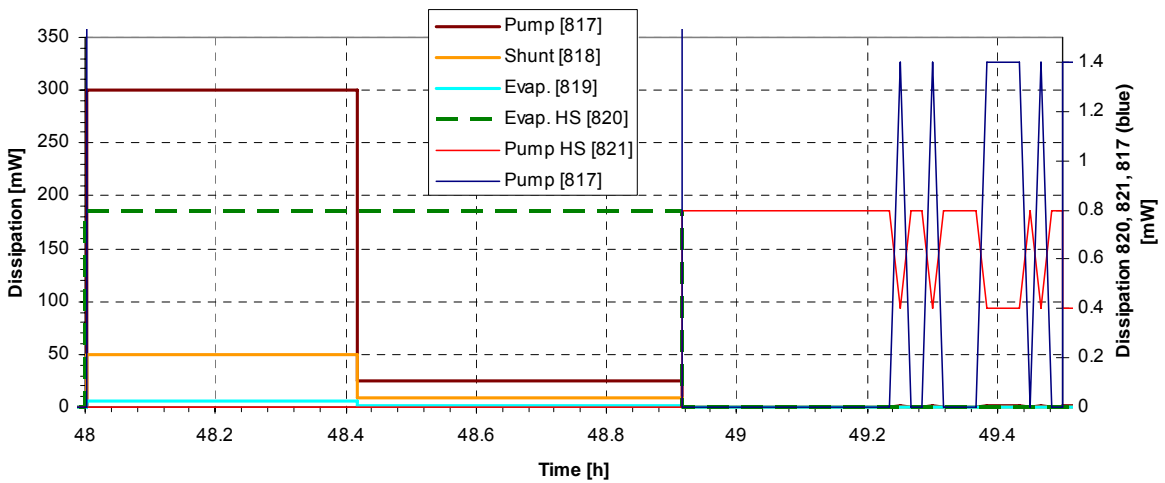

Figure 4.5-6: SPIRE Dissipation Profile during Recycling

Item	Node	Material / Components	Mass [kg]	Size / Performance	IR Emissivity	Unit Level Requirement	Remark
PM Det. enclosure	809	Al, St. Steel, Invar, Silicon	3.91				
SM Det. enclosure	810	Al, St. Steel, Invar, Silicon	1.70				
Enclosure Strap	811		0.164				
Pump Strap	812		0.159				
Evap. Strap	813		0.152				
Enclosure Strap I/F	814	Thermal link to HTT (L0) Al1050 pod	0.462	4 x M4 at Instr. I/F cross sect.: 960 mm ² , l=0.340m 8 x M5 at HTT I/F		R-OBA-345 [RD 23]	
Pump Strap I/F	815	Thermal link to HTT (L0) Al1050 pod	0.516	4 x M4 at Instr. I/F cross sect.: 960 mm ² , l=0.340m 8 x M5 at HTT I/F		R-OBA-345 [RD 23]	
Evap. Strap I/F	816	Thermal link to HTT (L0) Al1050 pod	0.701	4 x M4 at Instr. I/F cross sect.: 960 mm ² , l=0.340m 8 x M5 at HTT I/F		R-OBA-345 [RD 23]	
Cooler Pump	817	Ti	0.15				
Cooler Shunt	818	Ti	0.01				
Cooler Evaporator	819	Ti	0.084				
Cooler Evapor. HS	820	Ti	0.074				
Cooler Pump HS	821	Ti	0.074				
PM Detector	822	Invar, Cu	1.144				
SM Detector	823	Invar, Cu	0.535				
L1 strap I/F1	800	Cooling strap to GHe ventline (L1) Cu flexible strap	0.001	0.5 x M8 + 1 x M4 at Instr. I/F cross sect.: (20x2)mm, l=0.173m 4 x M4 at ventline I/F		R-OBA-345 [RD 23]	
L1 strap I/F2	830	Cooling strap to GHe ventline (L1) Cu flexible strap		0.5 x M8 + 1 x M4 at Instr. I/F cross sect.: (20x2)mm, l=0.173m 4 x M4 at ventline I/F		R-OBA-345 [RD 23]	

Item	Node	Material / Components	Mass [kg]	Size / Performance	IR Emissivity	Unit Level Requirement	Remark
SPIRE Optical Bench (SOB)	803	1 SST cone support to OBP 2 A-frame supports to OBP	26.75	aperture A/L= 1.530 mm various serials	0.05 1.0		
RF Filter box	804	Al casing/structure	1.465				harness I/F
BSM	805		1.10				
SMECM	806		1.043				
PM Calibration	807		0.03				
SM Calibration	808		2.041E-4				
PM JFET Encl.	801	Al, 5 CFRP T300 brackets to OBP	2.348	Total A/L= 36.63 mm	0.20		harness I/F
PM JFET I/F	831	Cooling strap to Level 3 Cu flexible strap		2 x M4 at Instr. I/F cross sect.: (20x4)mm, l=0.252m 4 x M4 at ventline I/F			
SM JFET Encl.	802	Al, 4 CFRP T300 brackets to OBP	0.81342	Total A/L= 29.30 mm	0.20		harness I/F
SM JFET I/F	832	Cooling strap to Level 3 Cu flexible strap		2 x M4 at Instr. I/F cross sect.: (20x4)mm, l=0.308m 4 x M4 at ventline I/F			

Table 4.5-2: Item List for SPIRE

4.5.3 HIFI

The HIFI instrument TMM thermal network is illustrated in Figure 4.5-7. All thermal nodes are represented in this sketch and are also compiled in Table 4.5-3 together with the design and performance data of the thermal links to the Level 0 and Level 1 interfaces.

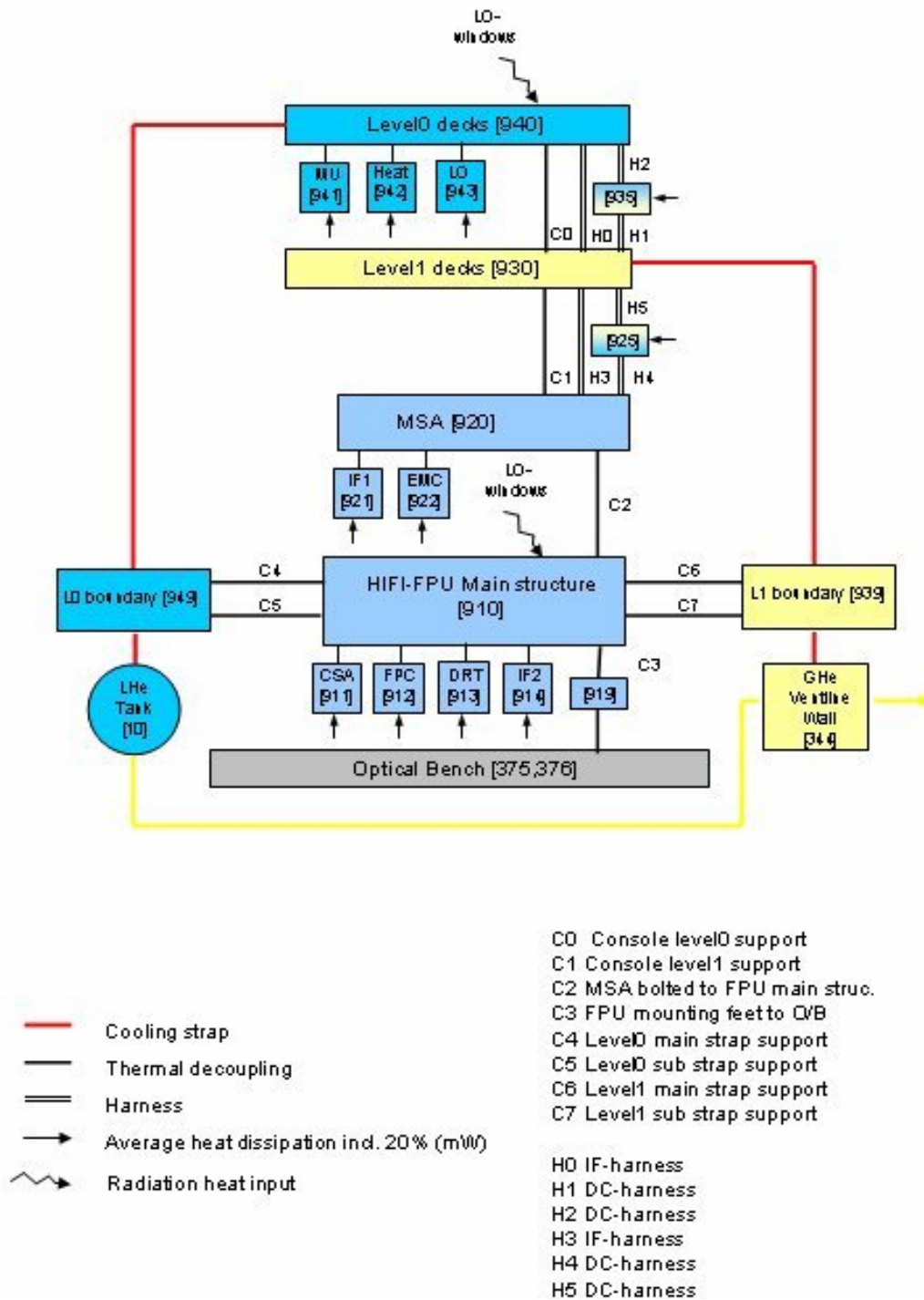

Figure 4.5-7: Reduced HIFI Instrument TMM

The dissipation timeline during HIFI operation is shown in Figure 4.5-8.

The following radiative couplings (GR) from the LOU windows (Node 4090 in H-EPLM TMM) to the HIFI Level 0 exist:

GR (4090 , 940) = 1.02E-5 m²

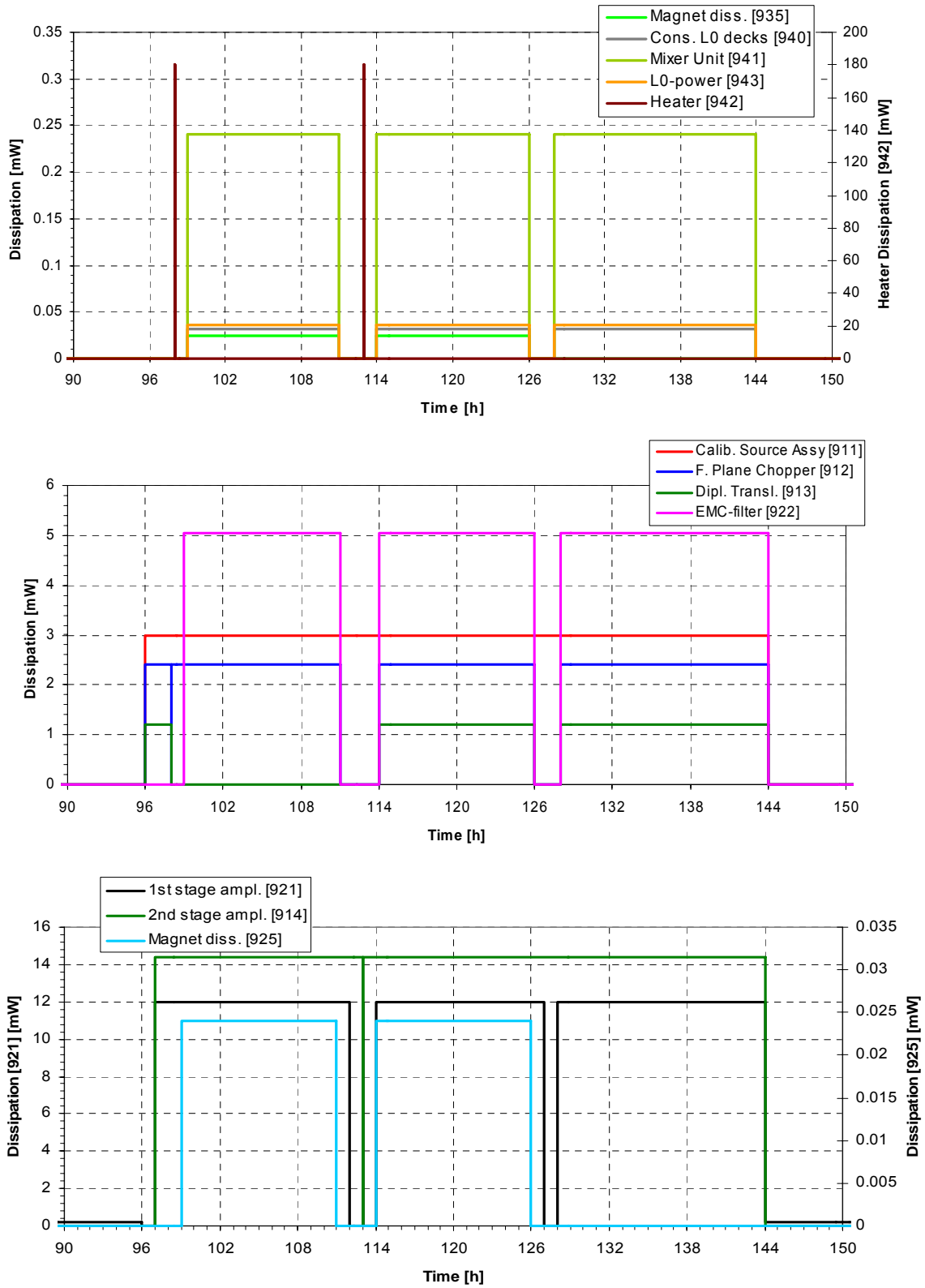

Figure 4.5-8: HIFI Dissipation Profile during Operation

Item	Node	Material / Components	Mass [kg]	Size / Performance	IR Emiss.	Unit Level Requirement	Remark
FPU Structure	910	Al	35.72	Apertures	0.26 1.0		harness I/F
Calib. Source Assy	911	Al	1.5				
Focal Plane Chopper	912	Al	0.40				
Dipl. Rooftop transl.	913	Al	0.59				
2 nd stage amplifier	914	Al	2.30				
L2 boundary	919			thermal coupl. to OBP: 1.2 W/K			
Mixer Sub Assy	920	Al	2				
1 st stage amplifier	921						
EMC filtering	922						
Magnet current diss.	925						
Console L1 decks	930	Al	0.56				
Magnet current diss.	935						
L1 boundary	939	Al, Cu Cooling strap to GHe ventl. (L1)	0.40	4 x M4 at Instr. I/F cross sect.: (20x3.5)mm, l=0.172m 4 x M4 at ventline I/F		R-OBA-345 [RD 23]	
Console L0 decks	940	Al	1.68				
Mixer Unit	941	Al	1.05				
Heater	942						
LO-power	943						
L0 boundary	949	Al, Thermal link to HTT (L0) Cu flexible strap Al 1050 pod	0.40	4 x M4 at Instr. I/F cross sect.: 75 mm ² , l=0.236m 4 x M4 cross sect.: 392 mm ² , l=0.404m 8 x M5 at HTT I/F		R-OBA-345 [RD 23]	

Table 4.5-3: Item List for HIFI

4.6 Thermal Shields and Tank Suspensions

The tank suspension consists of GFRP and T300 CFRP chains with heat interceptions at each Thermal Shield. The two innermost chains are made out of T300 CFRP; the other ones are made out of S-glass. The cross section and material selection of each chain has been optimized w.r.t. thermal and mechanical performance. The details are described in [RD 20]. The nodal breakdown of the chains is shown in Figure 4.6-1 and the relevant data are compiled in Table 4.6-1.

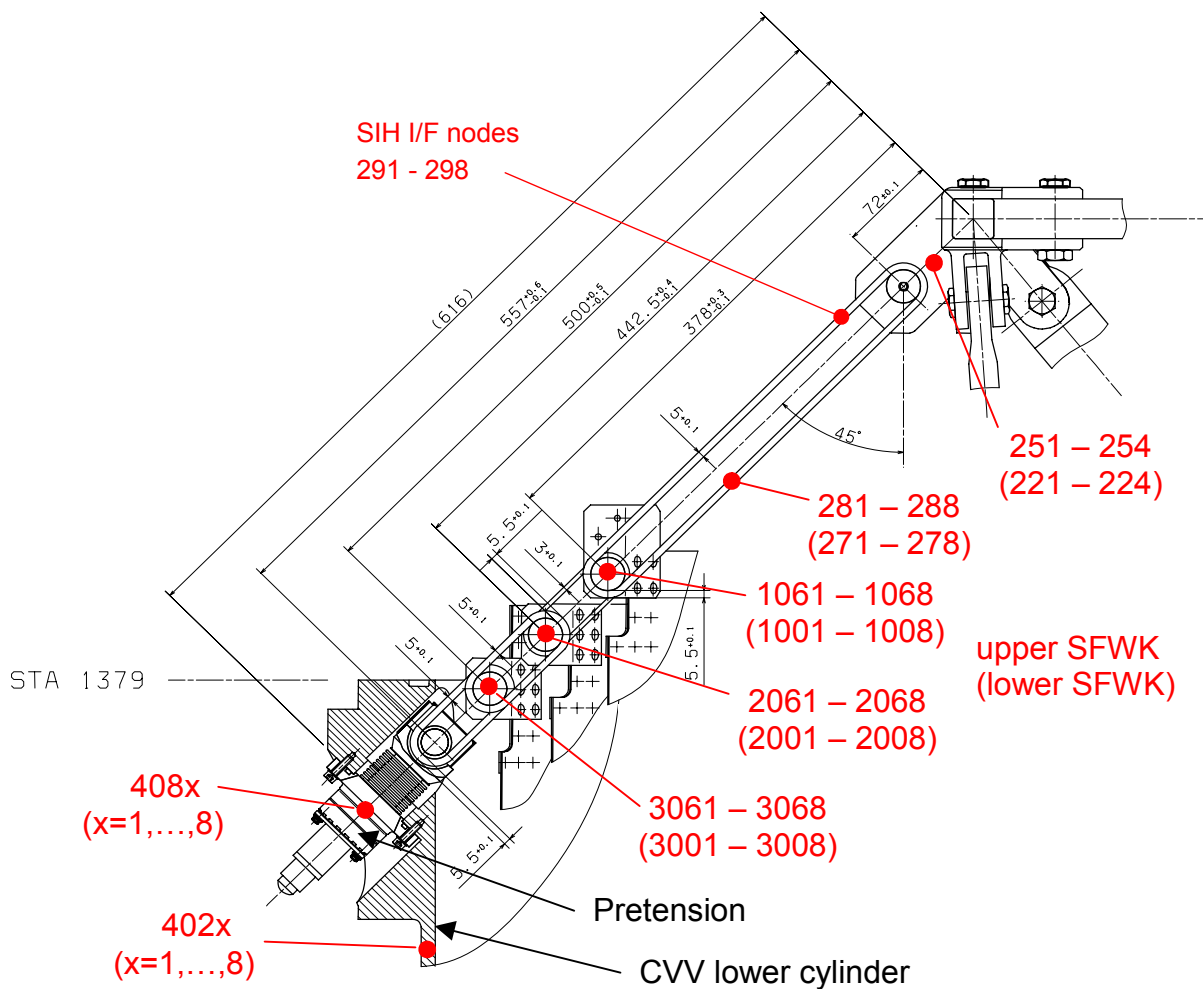

Figure 4.6-1: Nodal Breakdown of Tank Suspensions

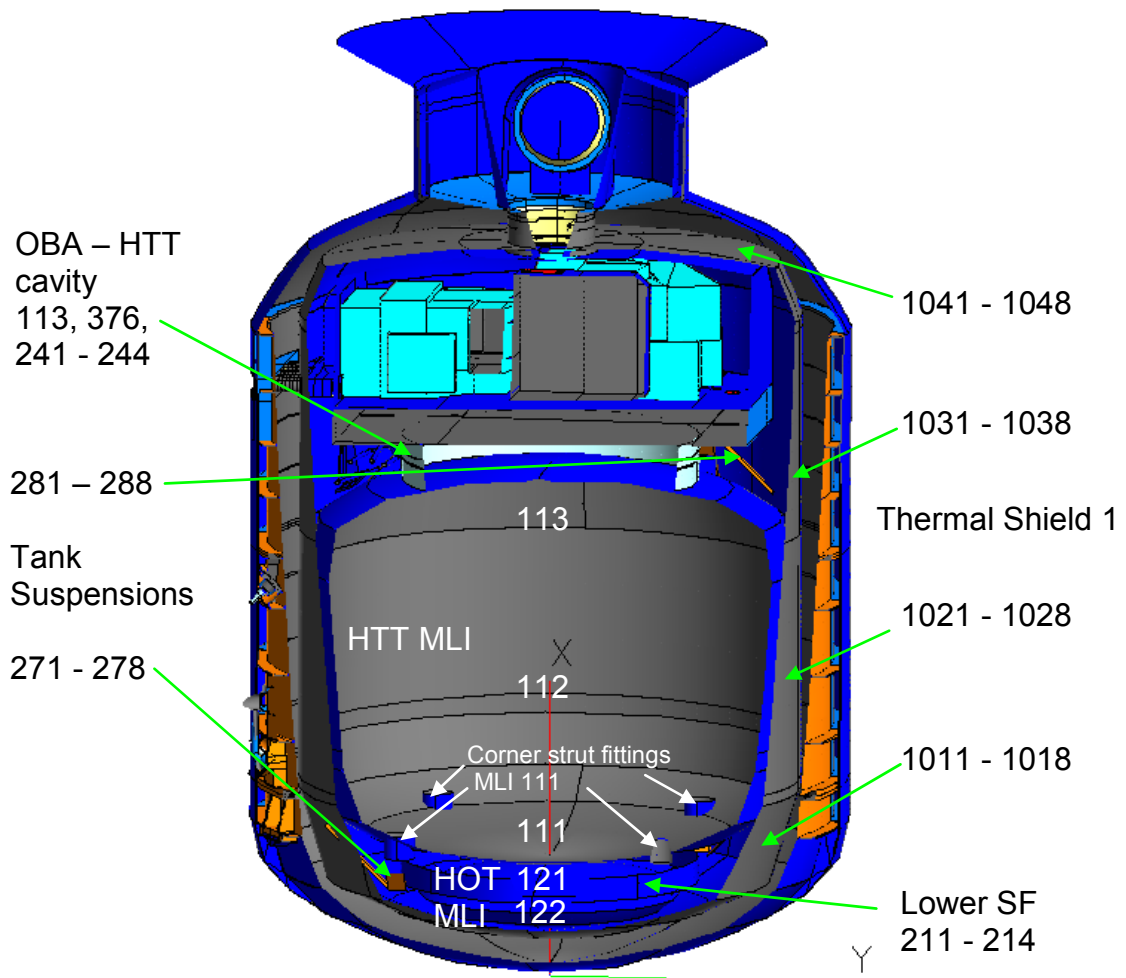

Figure 4.6-2: Nodal Breakdown of Tanks and Thermal Shield 1

Item	Node	Material / Components	Mass [kg]	Size	IR Emiss.	Unit Level Requirement	Remark
Susp. Bolt TS1 lo	1001-1008	stainless steel	0.15				
Susp. Bolt TS1 up	1061-1068	stainless steel	0.15				
Susp. Straps lo	271-278	8 CFRP T300, between TS1 and SFW		8x137 mm ² , l= 306 mm	0.8	R-TSS-200 [RD 21]	A)
Susp. Straps up	281-288	8 CFRP T300, between TS1 and SFW		8x137 mm ² , l= 306 mm			
Thermal Shld 1 low bulk	1011-1018	Al 6061	10.0	A= 3.708 m ² , s=0.8 mm	0.05	R-FTS-170 [RD 30]	
Thermal Shld 1 low cyl.	1021-1028	CuBe blades to TSS	12.1	D=1.69m, h=0.842m, s=0.8 mm			
Thermal Shld 1 upp cyl.	1031-1038		10.0	D=1.69m, h=0.696m, s=0.8 mm			
Thermal Shld 1 upp bulk	1041-1048		8.2	A= 3.021 m ² , s=0.8 mm			
TS 1 LOU Baffle	1090	Common Al baffle for all 7 HIFI chanel + 2 alignment apertures			0.7 int. C) 0.1 ext.		[RD 55]
Thermal Shield 1 MLI	1111-1118 1121-1128 1131-1138 1141-1148	2 x 5 layers	1.9 2.0 1.9 1.4	A= 3.708 m ² D=1.69m, h=0.842m D=1.69m, h=0.696m A= 3.021 m ²	0.05	R-INM-0510 [RD 24] R-INM-0530 [RD 24]	B)
Susp. Bolt TS2 lo	2001-2008	stainless steel	0.15				
Susp. Bolt TS2 up	2061-2068	stainless steel 2x8 CFRP T300, susp. straps to TS1	0.15	2x8x131 mm ² , l= 64.5 mm		R-TSS-200 [RD 21]	A)
Thermal Shld 2 low bulk	2011-2018	Al 6061	11.1	A= 4.124 m ² , s=0.8 mm	0.05	R-FTS-173 [RD 30]	
Thermal Shld 2 low cyl	2021-2028	CuBe blades to TSS	12.6	D=1.76m, h=0.842m, s=0.8 mm			
Thermal Shld 2 upp cyl.	2031-2038		10.4	D=1.76m, h=0.696m, s=0.8 mm			
Thermal Shld 2 upp bulk	2041-2048		9.0	A= 3.319 m ² , s=0.8 mm			
Thermal Shield 2 Baffle	2050	Al baffle with aperture; cut-out area 0.040 m ² , see Figure 4.3-4		290 mm diameter	0.7 cyl. C) 0.7 +x side C) 0.05-x side		
TS 2 LOU Baffle	2090	Al tubes (LOU/HIFI) Al tubes (Alignment)		7 x 42 mm inner diameter 2 x 35 mm inner diameter	0.7 int. C)		[RD 55]
Thermal Shield 2 MLI	2111-2118 2121-2128 2131-2138	4 x 5 layers	2.1 2.1 1.9	A= 4.124 m ² D=1.76m, h=0.842m D=1.76m, h=0.696m	0.05	R-INM-0610 [RD 24] R-INM-0630 [RD 24]	B)

Item	Node	Material / Components	Mass [kg]	Size	IR Emiss.	Unit Level Requirement	Remark
	2141-2148		1.7	A= 3.319 m ²			
Susp. Bolt TS3 lo Susp. Bolt TS3 up	3001-3008 3061-3068	stainless steel stainless steel 2x8 GFRP suspension straps to TS2 2x8 GFRP suspension straps to CVV	0.15 0.15	2x8x168 mm ² , l= 57.5 mm 2x8x167 mm ² , l= 57 mm		R-TSS-200 [RD 21]	A)
Thermal Shld 3 low bulk Thermal Shld 3 low cyl.	3011-3018 3021-3028	Al 6061 CuBe blades to TSS	12.2 kg 13.1 kg	A= 4.503 m ² , s=1mm D=1.83m, h=0.842m, s=1mm	0.05	R-FTS-173 [RD 30]	
Thermal Shld 3 upp cyl. Thermal Shld 3 upp bulk	3031-3038 3041-3048		10.8 kg 10.5 kg	D=1.83m, h=0.696m, s=1mm A= 3.886 m ² , s=1mm			
Thermal Shield 3 MLI	3111-3148	4 x 5 layers	2.5 kg 4.6 kg 2.1 kg		0.05	R-INM-0710 [RD 24] R-INM-0730 [RD 24]	B)

A) Thermal conductivity of material confirmed by sample tests

B) MLI Performance test data of Forschungszentrum Karlsruhe included (details are reported in [RD 36])

C) 0.85 for ground cases, to account for higher temperatures

Table 4.6-1: Item List for Thermal Shields

The thermal property data of the cryostat internal MLI are described in Section 5.1.

4.7 Cryostat Vacuum Vessel and Radiators

The nodal break-down of the CVV is shown in Figure 4.7-1. About one half of the cylindrical part and a 90° section of the upper bulkhead of the CVV serve as radiator, this area is called the CVV main radiator. The remaining surface of the CVV is covered with MLI. Three additional radiators are located at the -Z, +Y and -Y sides.

The ±Y radiators shadow the CVV main radiator from the warm Solar Array MLI and increase further the CVV radiative area to space. The radiator (-Z) side of the ±Y radiators (as well as both sides of the -Z radiator) are black anodized. The rear (+Z) sides of the ±Y radiators are covered with MLI.

The -Z radiator is split in an upper and a lower part, with the nozzle assembly in between. The thermal / mechanical attachment of each radiator to the CVV is provided with M8 bolt connections as listed in Table 4.7-1. The contact conductance between radiators and CVV structure are calculated using the values shown in Figure 5.3-1.

The heat spreading effect on CVV and radiators has been taken into account in the TMM using appropriate formulas in the corresponding “GL” conductance calculations (serial conductance of contact conductance and linear conductance of the corresponding CVV radiator). On the CVV two arithmetic nodes are located at the -Z Radiator I/F on the lower (node 4051) and upper part (4052). Thus, node 4051 connects the radiator node 4050 with the CVV nodes 4024 and 4025. Node 4052 connects the radiator node 4053 with the CVV nodes 4034 and 4035.

Detailed modelling of CVV external items in the GMM like CVV ribs, connector plugs, pretension devices, external tubing/LHVs, nozzles etc. is shown in Figure 4.7-2 and Figure 4.7-3.

The cryostat baffle that is located between the telescope and the CVV upper bulk has an additional so-called “SLI I/F collar”. This device ensures the light-tightness of the interface between telescope and cryostat baffle towards the external environment, see Figure 4.7-4. The external surface of this baffle is covered with MLI except a 90° section at the -Z side that serves as radiator area and is black anodized. The internal surface has a low IR emissivity. Inside the cryostat baffle there is an additional internal conical baffle with a low IR surface emissivity, providing minimum disturbance of the instruments main optical path (beam entrance).

The optical path between HIFI and LOU is visualised in Figure 4.7-5. Two dedicated baffles with integrated vanes are implemented on Thermal Shield 1 and 2 [RD 55].

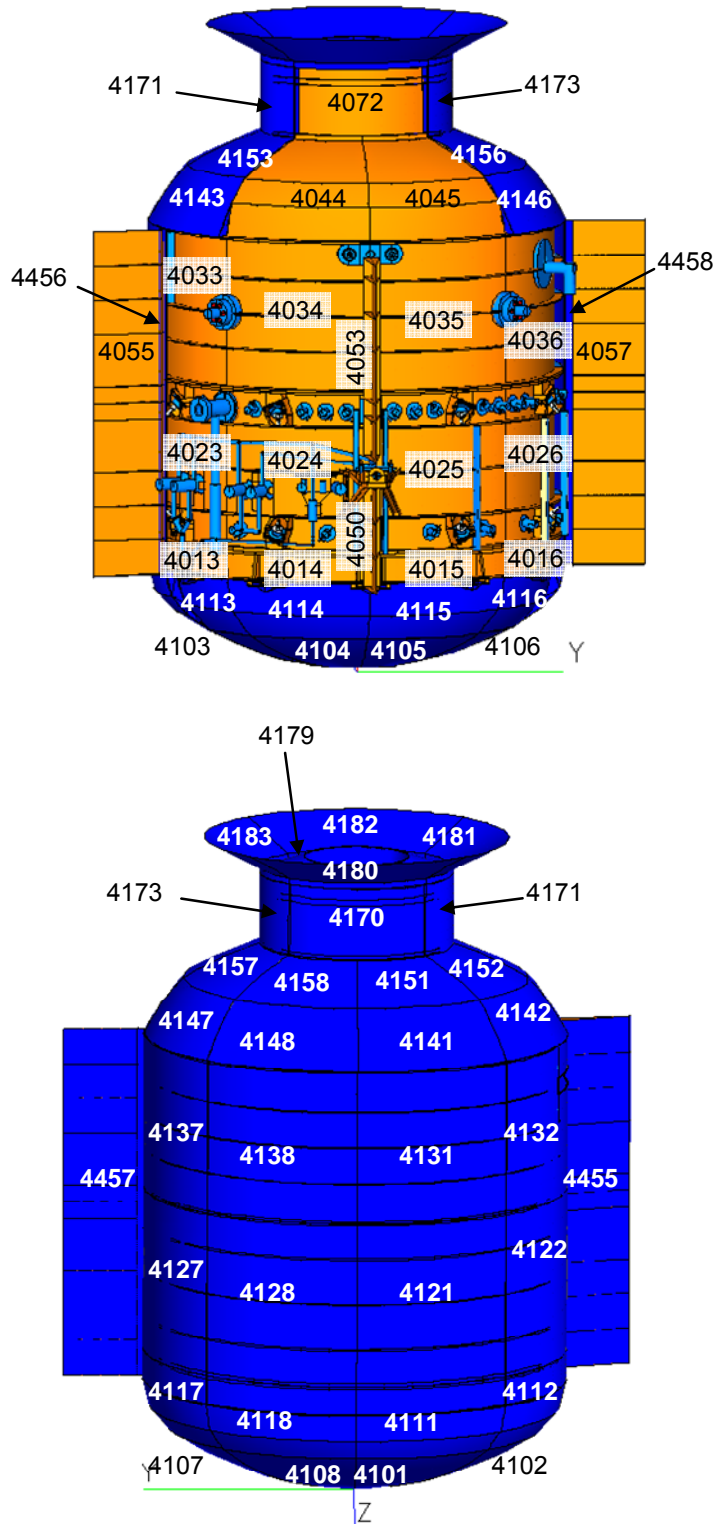

Figure 4.7-1: CVV Radiator and MLI Nodal Break-Down

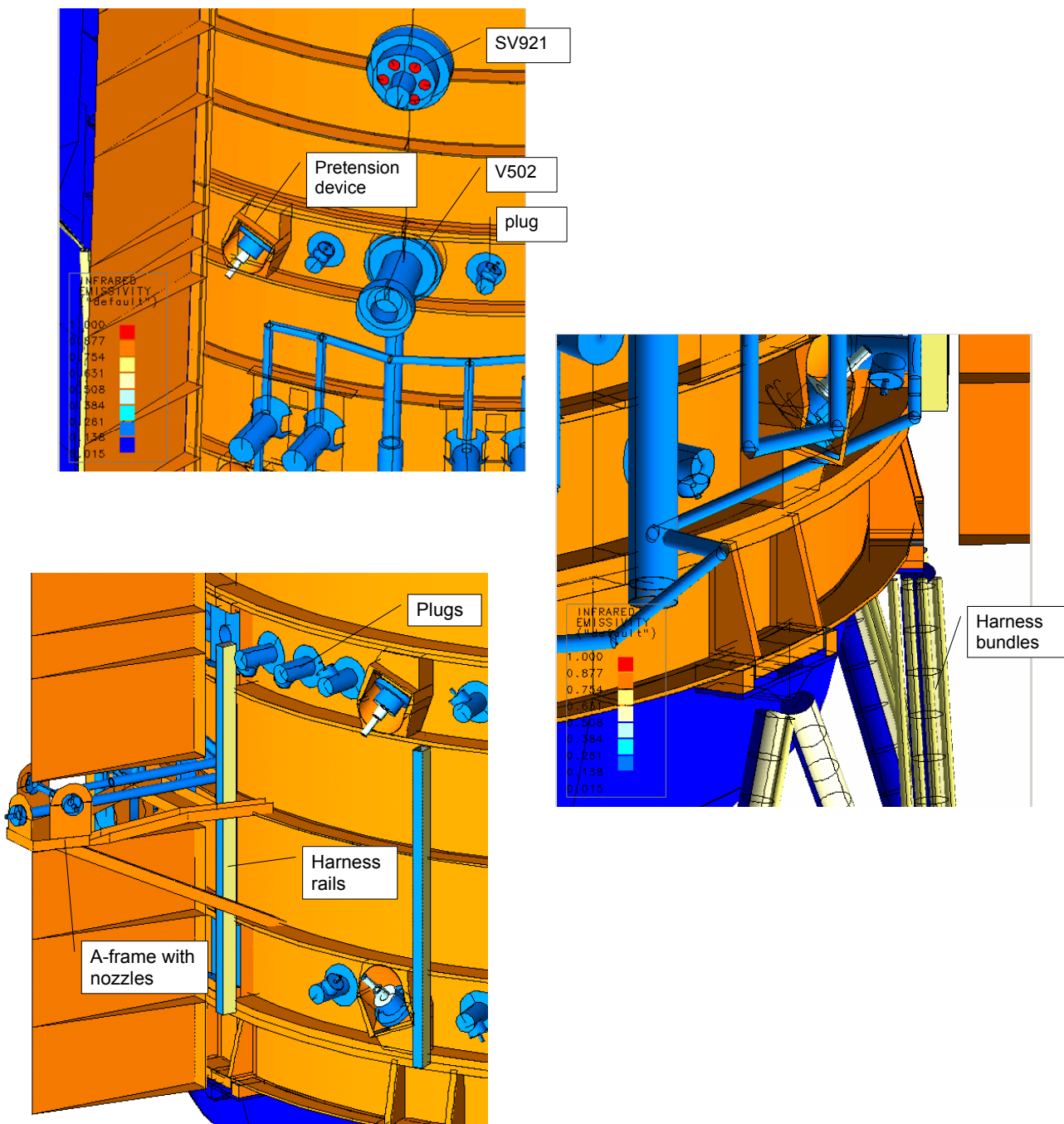

Figure 4.7-2: Detailed view on CVV external items (CVV ribs, connector plugs, pretension devices, external tubing with LHV, A-frame with nozzles, harness bundles & rails)

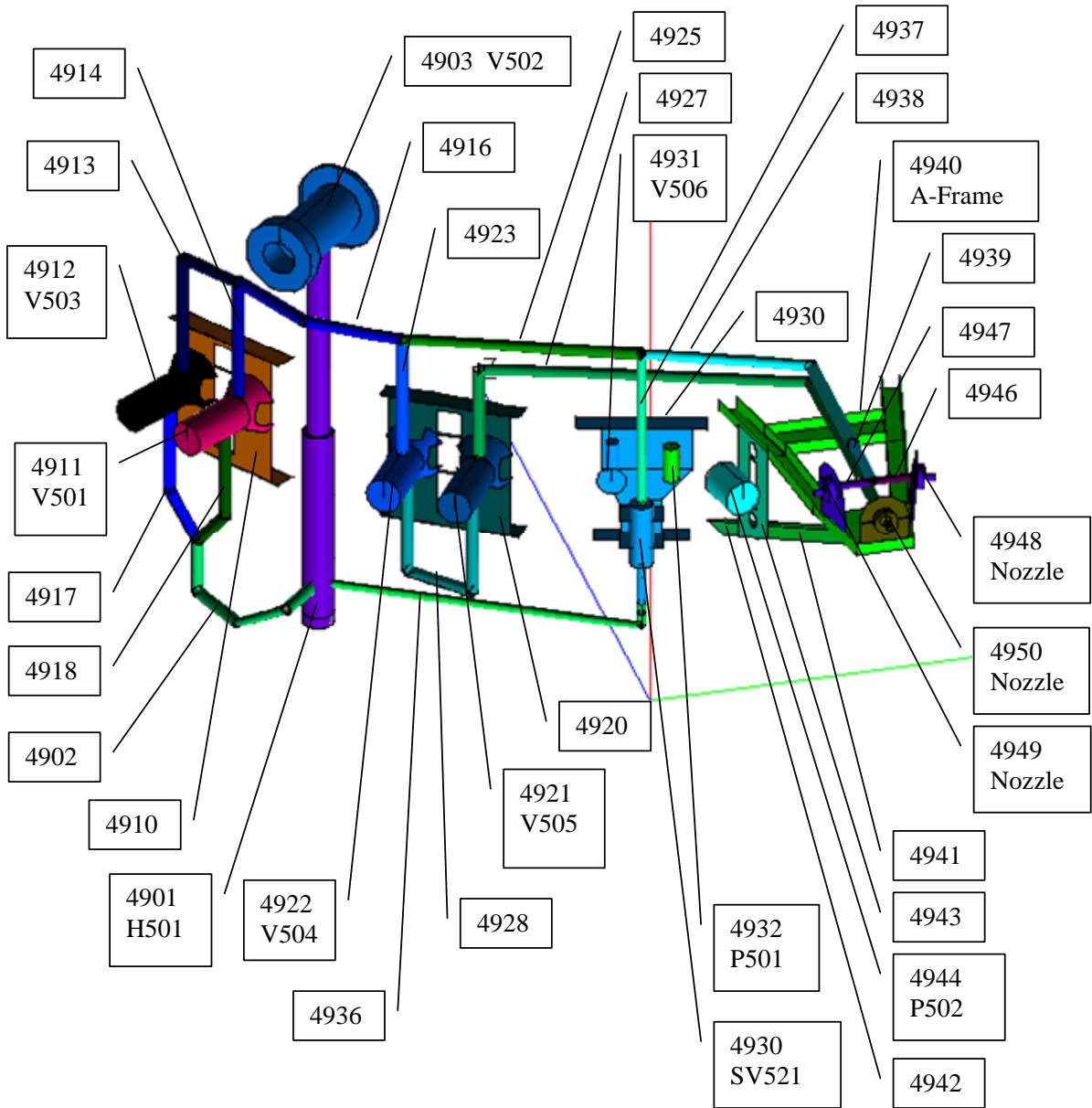

Figure 4.7-3: External tubing Nodal Breakdown

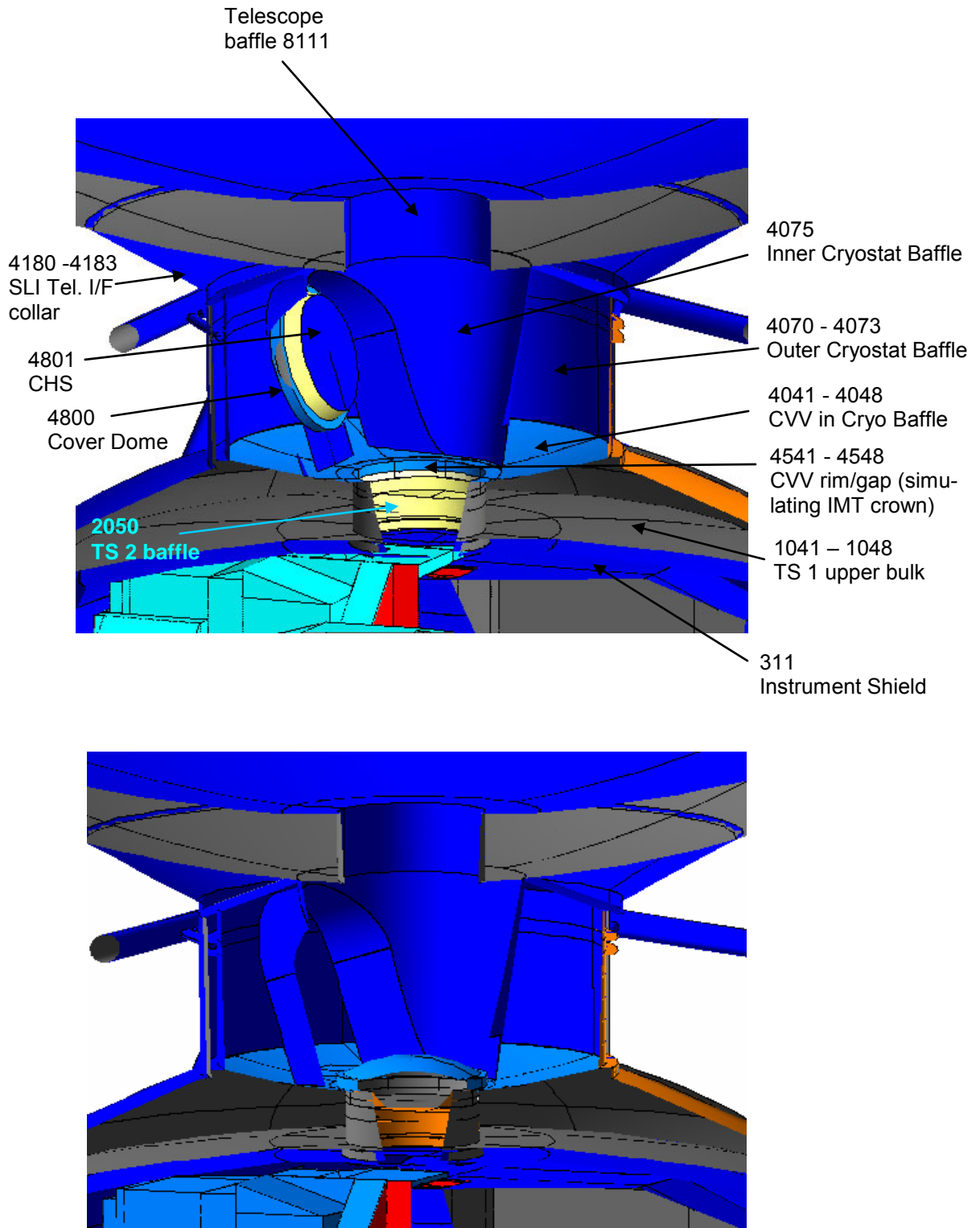

Figure 4.7-4: Cryostat Baffle and Cover Nodal Break-Down (Cover open & closed View)

Thermal conductance due to gaseous Helium in the Cryo Cover flushing line

According to [RD 39], the total linear heat conductance between the Cover and the CHS is 0.00325 W/K. The cited value does not include the heat conduction through the gaseous Helium, which is left in the tube after cover flushing. To avoid leakage of air and water vapour into the flushing lines, the lines will be sealed off with a slight He overpressure inside during the ground hold time / launch autonomy.

For the current worst-case calculation, a Helium pressure of 1.5 bar (150kPa) is assumed. The thermal conductivity of He varies between 0.137 W/mK and 0.156 W/mK for temperatures between 250 K and 300 K according to NIST. Two parallel stainless steel (1.4404) lines, free effective length $L = 60$ mm, outer diameter $d_a = 5.0$ mm, inner diameter $d_i = 4.6$ mm [RD 39]. This leads to a pipe wall conductance of 0.0015 W/K.

Since the warm part (Johnston coupling) is above the cold part (CHS), convection will not take place. Conduction in the He gas is:

$$C = 2 \cdot \lambda \cdot \frac{\pi d_i^2}{4L} = 8.30951E - 05 \text{ W/K}$$

This linear conductor is also implemented in the TMM.

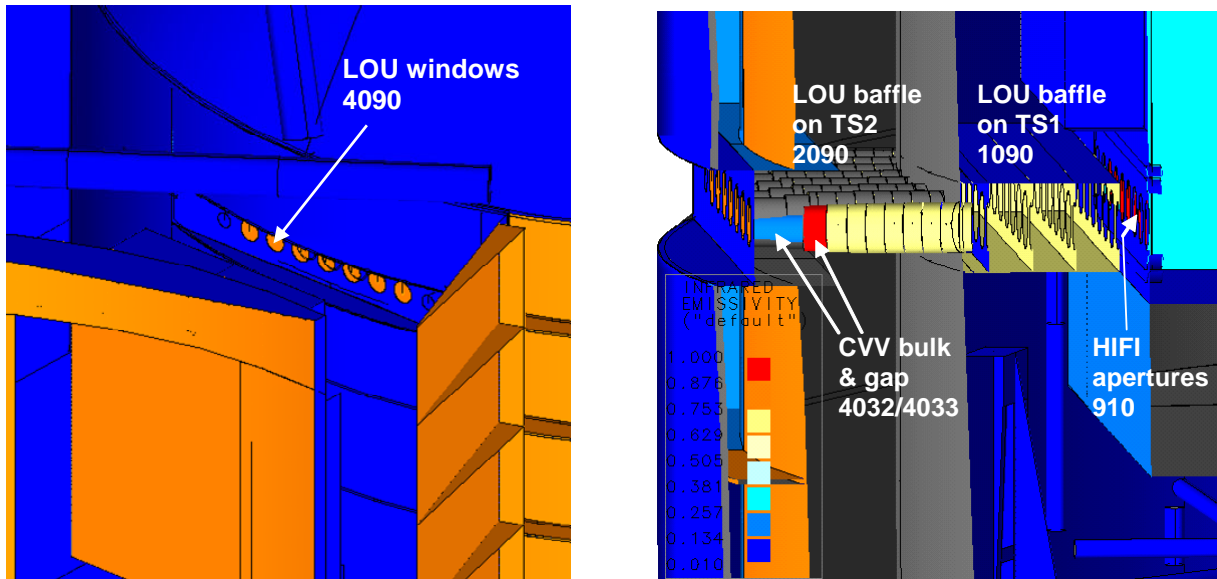

Figure 4.7-5: LOU Windows / Baffles

Item	Node	Material / Components	Mass [kg]	Size	Solar Absorpt.	IR Emiss.	Unit Level Requirement	Remark				
CVV lower bulk	4011-4018	Al 5083, 3.3547 Radiator area outside: black anodized (78/60 μm thickn. upper/lower CVV); (1) = ε @ 65 K (in-orbit) (2) = ε @ 100 K (LSS) inner side: polished (3)	88.5	A= 8 x 0.585 m ² 7 mm thickness (average)	0.95 (1)	0.79 (1) 0.81 (2) 0.05 (3)	R-CVV-F-640 [RD 31] R-CVV-F-645 [RD 31]	A)				
CVV lower cylinder	4021-4028		95.0	D = 1.9 m, h=0.842 m 7 mm thickness (average)								
CVV upper cylinder	4031-4038		78.5	D = 1.9 m, h= 0.696 m 7 mm thickness (average)								
CVV upper bulk	4041-4048		78.1	A= 8 x 0.516 m ² 7 mm thickness (average)								
CVV lower bulk MLI	4101-4108 4111-4118 Inner side 4411-4412 Inner side 4417-4418	41 layers (4 blankets: 3x9+1x14) IR specularity 0.80			0.13	0.05	R-EXM-530 [RD 28]					
CVV lower cyl. MLI	4121-4122 4127-4128 Inner side 4421-4422 Inner side 4427-4428											
CVV upper cyl. MLI	4131-4132 4137-4138 Inner side 4431-4432 Inner side 4437-4438											
CVV upper bulk MLI	4141-4148 4151-4158											
CVV -Z Radiator (+X)	4053		Al 6063, both sides with micro grooves and black anodized (72 μm thickness)	3.021				(0.35 x 0.968) m ² 15 x M8	0.95	0.85 (1) 0.86 (2)	R-CVV-F-480 [RD 31]	A)
CVV -Z Radiator (-X)	4050		Al 6063, both sides with micro grooves and black anodized (72 μm thickness)	1.703				(0.35 x 0.506) m ² 9 x M8	0.95	0.85 (1) 0.86 (2)	R-CVV-F-480 [RD 31]	A)
CVV -Y Radiator	4055		Al 6063, -Z side with micro grooves and black anodized (70 μm thickness)	4.534				(0.35 x 1.687) m ² 24 x M8	0.95	0.84 (1) 0.85 (2)	R-CVV-F-485 [RD 31]	A)
CVV +Y Radiator	4057	Al 6063, -Z side with micro grooves and black anodized (71 μm thickness)	4.568	(0.35 x 1.687) m ² 24 x M8	0.95	0.83 (1) 0.84 (2)	R-CVV-F-485 [RD 31]	A)				
CVV -Y Radiat. MLI	4455, 4456	41 layers (4 blankets: 3x9+1x14) IR specularity 0.80			0.13	0.05	R-EXM-530 [RD 28]					
CVV +Y Radiat. MLI	4457, 4458											

Item	Node	Material / Components	Mass [kg]	Size	Solar Absorpt.	IR Emiss.	Unit Level Requirement	Remark
LOU Windows	4090	Quartz Glass windows (LOU), 5 mm thick Quartz Glass windows (Alignment) 5 mm thick		7 x Ø34 mm opening in CVV 2 x Ø24 mm opening in CVV	0.05	0.8		IR transm. 0.20
Cover	4800	If opened: -107° rotated around Y axis	7			0.15	R-CC-090 [RD32]	
Cover Heat Shield	4801	Heat shield rim/short cone	0.46			0.1 0.7	R-CC-080 [RD32]	
Outer Cryostat Baffle	4070-4073, 4079 4072	Al 5083 90° radiator section	5	D=850mm 0.229 m ²		0.1 0.80 (1) 0.82 (2)	R-CB-135 [RD32] R-CB-135 [RD32]	A)
Inner Cryostat Baffle	4075	Al 5083 outer surface	1	Conical: D=500, d=300		0.05 0.1	R-CB-135 [RD32]	
Cryostat Baffle MLI	4170,4171, 4173,4179	41 layers (4 blankets: 3x9+1x14) IR specularity 0.80			0.13	0.05	R-EXM-830 [RD 28]	
SLI Tel. I/F collar	4180-4183	1 layer; IR specularity 0.80			0.13	0.05		
CVV gap	4541-4548	simulates IMT crown		D = 290mm, h = 14.5mm		0.6		
Pretension 1 - 8	4081-4088	Ti brackets	8 x 0.15		0.4	0.15		
Ext. Ventline & valves	4901-4962	Stainless steel			0.4	0.15		
CVV plugs	4023-4026 4033-4036	Stainless steel			0.4	0.15		
CVV ext. harness	9011-9096				0.7	0.7		
Harness rails	22100- 24344	Al			0.4 0.7	0.15 0.7		

A) Test results obtained from sample testing [RD 35]

Table 4.7-1: Item List for CVV and Cryostat Baffle

The thermal property data of the CVV MLI are described in Section 5.1.

4.8 LOU and Telescope

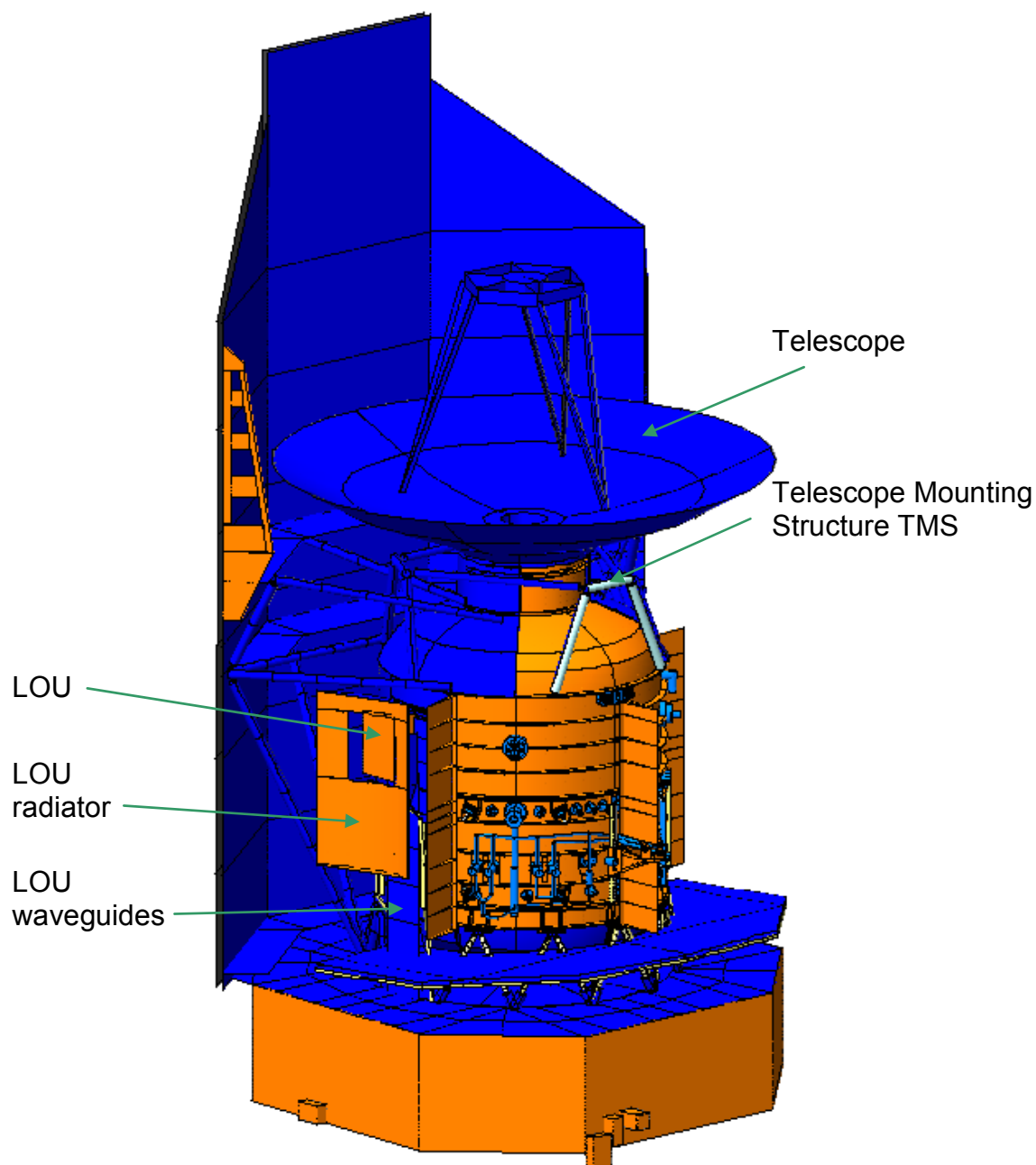

Figure 4.8-1: H-EPLM GMM External Overall View including H-SVM RGMM

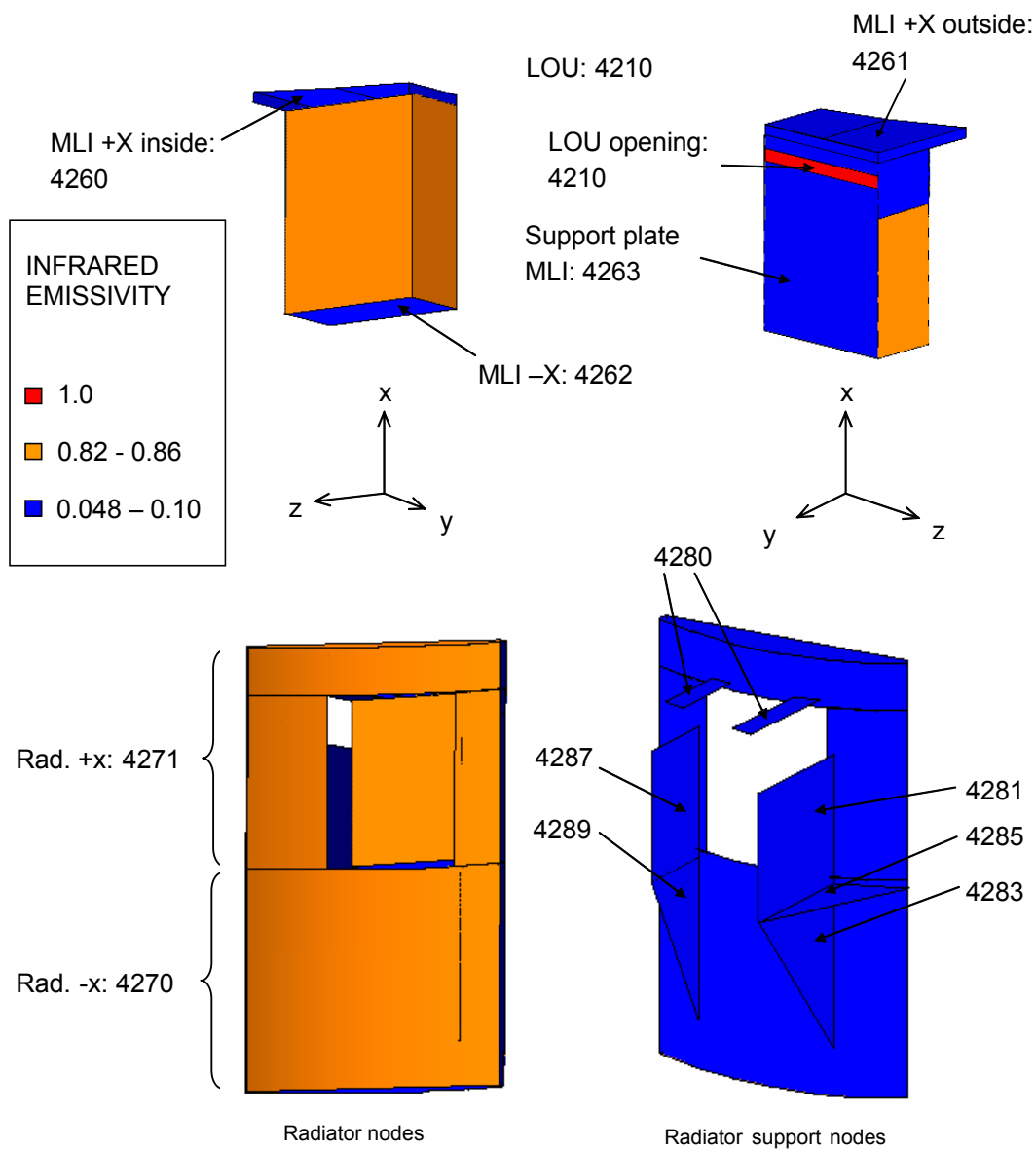

Figure 4.8-2: LOU & LOU Radiator GMM

LOU:

The LOU is modelled as one common box which is well-connected via the baseplate to the LOU support plate, and with a heat dissipation of 7 W [AD 01 and AD 04].

The LOU support plate is conductively isolated against the CVV via 8 GFRP struts, and is linked to the LOU radiator via the radiator supports. The LOU baseplate only has a poor direct link to the LOU radiator via the +x support straps.

In addition to the LOU radiator, the -Y side and also the +/-Z faces of the LOU serve as radiating areas, the other sides of the box are bare aluminium or covered with MLI.

The LOU waveguides are subdivided in 6 nodes, similar to the LOU harness, see Figure 4.8-3.

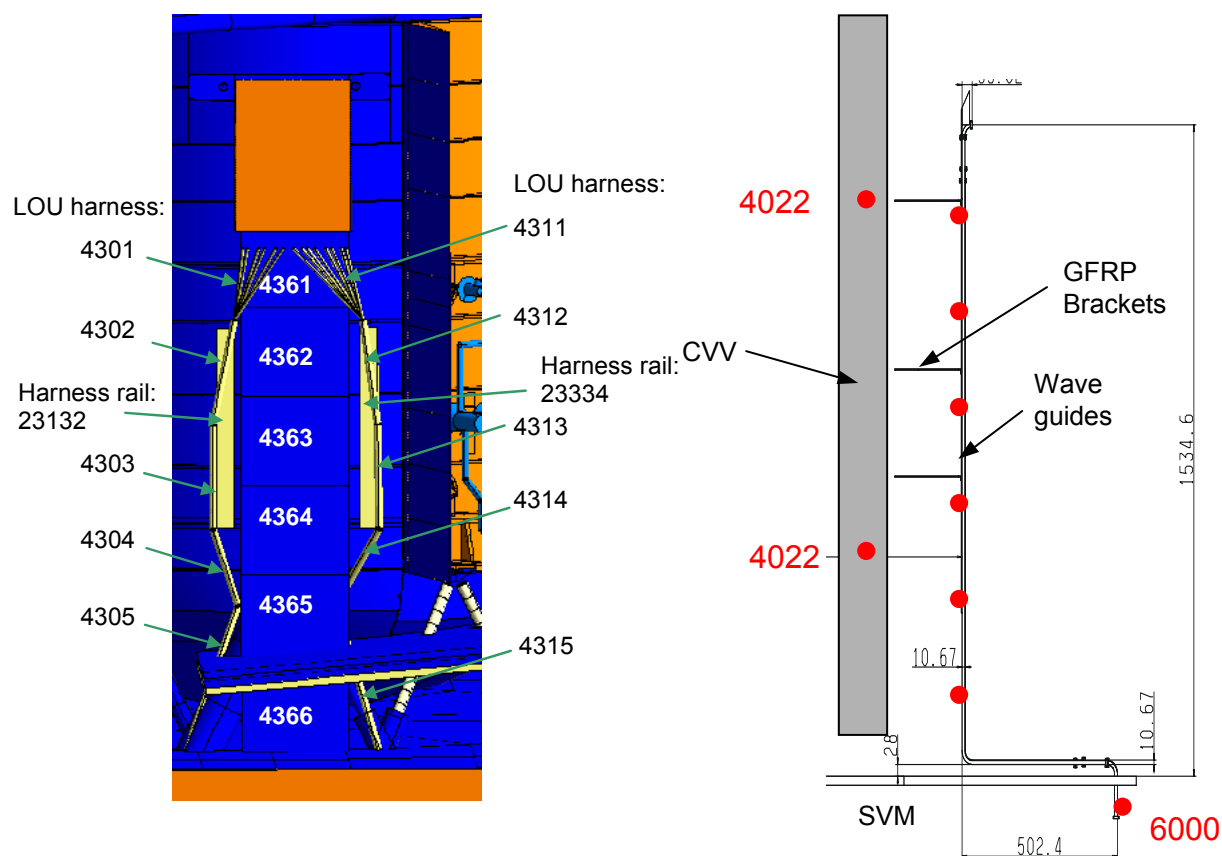

Figure 4.8-3: Nodal Breakdown of LOU Waveguides and Harness

Telescope/TMS:

The telescope GMM/TMM has been delivered by ESA [RD 29]. The node distribution and other thermal parameters are given hereafter, a cross-sectional view is given in Figure 4.7-4. A more detailed thermal design description (including also the SLI seen concept) can be found in [RD 54].

The Telescope Mounting Structure is wrapped in MLI, except the struts on -z side that are left open towards space for radiating, see Figure 4.8-1. The nodal breakdown of the TMS is shown in Figure 4.8-5.

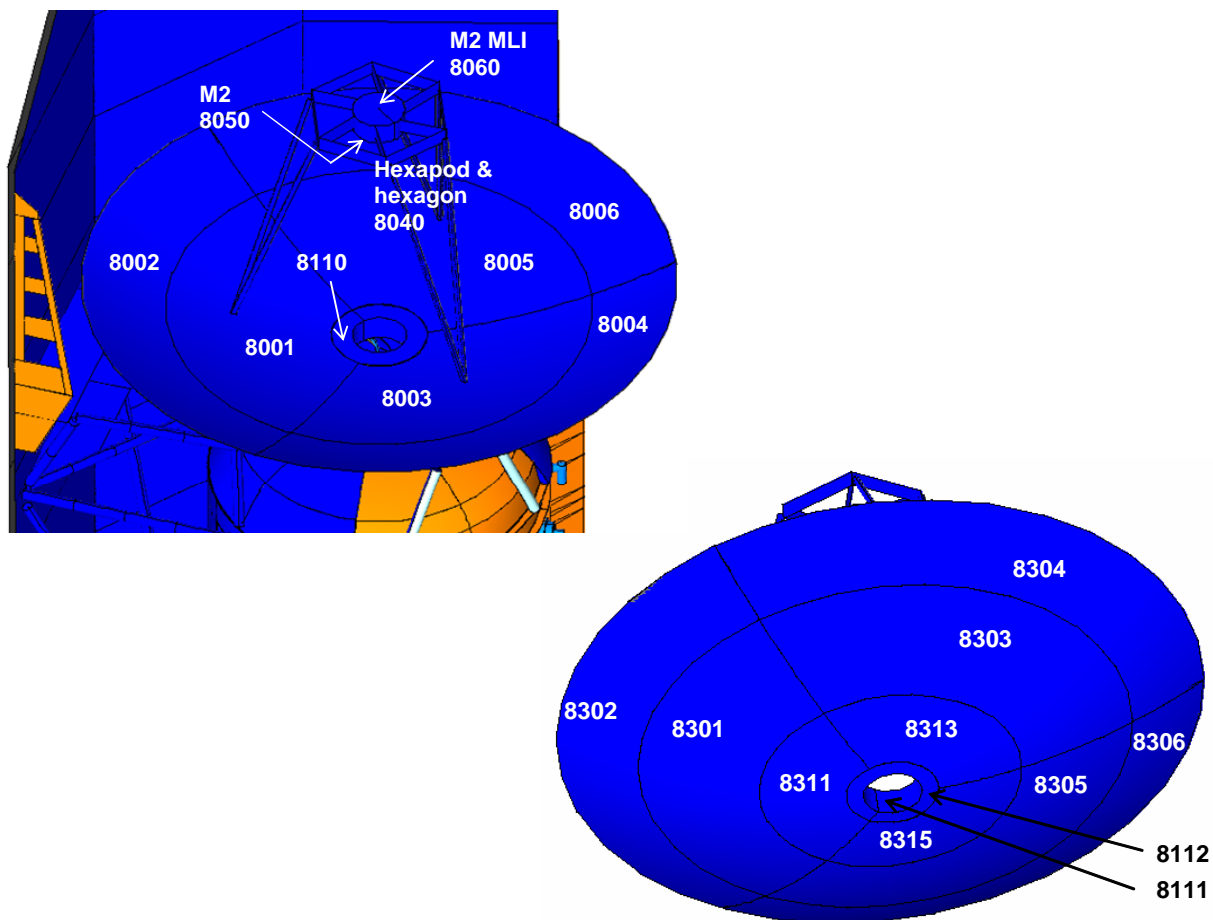

Figure 4.8-4: Telescope GMM

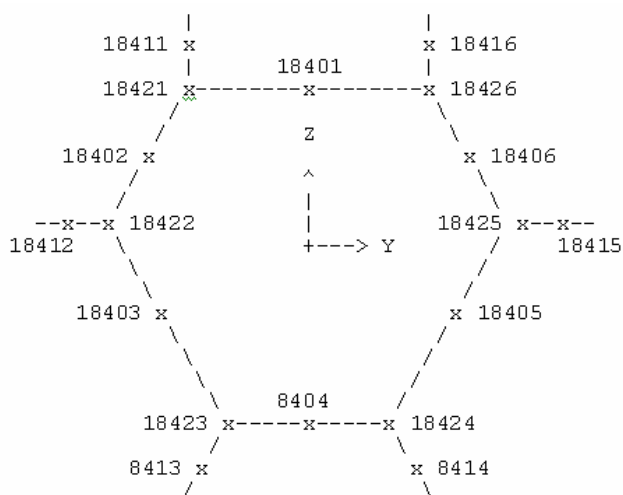

Figure 4.8-5: Schematic view of TMS

Item	Node	Material / Components	Mass [kg]	Size	Solar Abs.	Emissivity	Unit Level Requirement	Remark
LOU Support Structure	4201-4207, 4211-4217	Al 6061 8 GFRP E-glass struts to CVV 51xM5 to LOU baseplate (20+8)xM5 to LOU Radiator support		(507x439x10) mm Total A/L = 5.56 mm			R-SS-0330 [RD 25]	
LOU incl. baseplate radiative area (-Y) +/-Z side (partly) others	4210	thermally equivalent to Al 6xM5 to Radiator support (+x straps)	40	(466x352x170) mm 0.16 m ²	0.95 0.95 0.13	0.82 0.82 0.1		7 W dissipation
LOU MLI +/-X, +Y	4261-4263	41 layers (4 blankets: 3x9+1x14) IR specularity 0.75 to 0.80			0.13	0.05 – 0.1		
LOU Radiator	4270-4271	Front side: black painted Al		0.933 m ² 6.5 kg	0.95 0.95	0.86 front 0.048 rear		
LOU Rad. Support	4280-4289	Al, IR specularity 0.75			0.13	0.05		
LOU Waveguides	4361-4366	13x WR28 + 1xWR34 SST WG's to SVM GFRP WG support brackets to CVV	1.92	Total A/I = 3.6 mm	0.48	0.06		RD 34
LOU harness	4301-4316	76 mm ² Cu GFRP harness supports to CVV		Total A/I = 1.07 mm	0.7	0.7		
Telescope	8001-8006 8608-8620 8110-8112 8050 8040	M1 (SiC); IR specularity 0.921 Cond. to TMS: 0.049 W/K Cu harness to TMS from M1 & M2 Cu harness from TMS to SVM connec. Telescope Baffle M2 Mirror (SiC); IR specularity 0.921 Hexapod & hexagon (SiC)	279 6 17	Outer Ø 3.5 m A=23.2 mm ² , L=various A=8 mm ² , L=5.2 m Inner Ø 0.320 m	0.11 0.13 0.11 0.13	0.01 / 0.03 * 0.025 0.01 / 0.03 * 0.025		* Nom. in orbit/ decontamin.
TMS incl. MLI	8401-8416, 18401-18426	6 CFRP T300 struts to CVV 6 GFRP struts to Cryostat Baffle 14 layers MLI; IR specularity 0.80		Total A/L = 10.7 mm Total A/L = 2.0 mm	0.70 0.70 0.13	0.5 0.5 0.05	R-TMS-0330 [RD 27]	
Telesc. M1 MLI	8101-8106 8201-8315	"Two/three screen" concept IR specularity 0.80		D = 3.5 m, d = 0.320 m	0.13	0.025 / 0.05 *		* Nom. in orbit/ decontamin.

Table 4.8-1: Item List for LOU and Telescope

4.9 Harness

The harness implementation principle in the H-EPLM TMM is shown in Figure 4.9-1. Depending on the harness dissipation, the different harness branches are modelled either by dedicated nodes or via a thermal conductance coupling using thermal conductivity integral functions. For the latter ones, the harness dissipation is distributed to the corresponding interface at the cold end. An overview for the CVV internal harness modelling is given in Table 4.9-1.

Instrument	Branches with dedicated nodes	Branches with (integral) thermal conductance	Remark
PACS FPU	3	12	
SPIRE FPU	1	3	
HIFI FPU	5 + 4 x coax	0	
SPIRE JFET Phot.	1	6	
SPIRE JFET Spec.	0	2	

Table 4.9-1: Modelling of the CVV Internal Harness Branches in the EPLM TMM

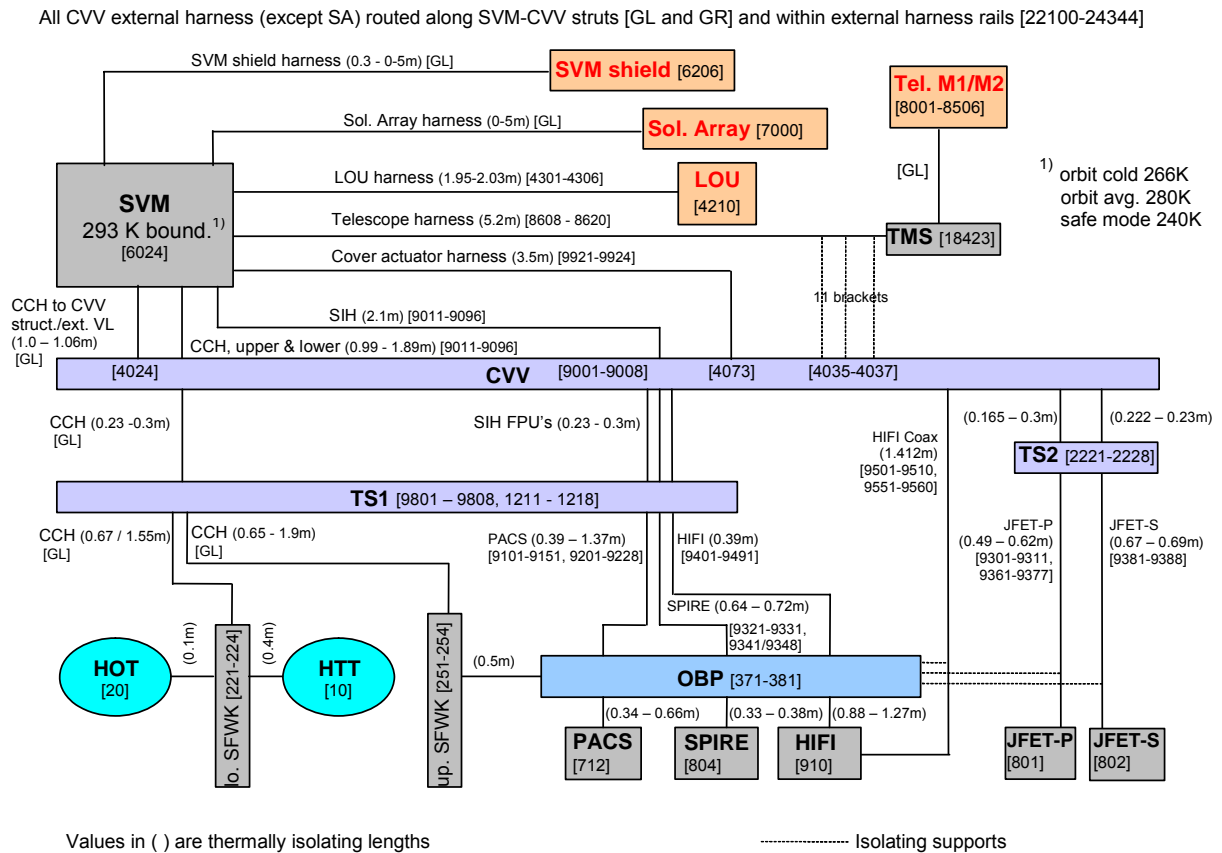

Figure 4.9-1: Harness Chart used in TMM

The LOU harness is routed in two bundles along the LOU waveguides on separate GFRP supports and is also modelled in the GMM, see Figure 4.8-3.

Harness bundles that are implemented by means of conductive couplings between the corresponding I/F nodes are indicated by "[GL]" in Figure 4.9-1, their dissipation is distributed to 100% to the corresponding cold end.

The cross-section and dissipation values of the scientific harness (SIH) and the cryostat control harness (CCH) have been evaluated based on the data listed in RD 02. The SIH data are summarized in Table 4.9-2 and Table 4.9-3; the CCH data are listed in Table 4.9-4 and Table 4.9-5.

The HIFI coax harness modelling has been refined with separate inner (silver coated CuBe) and outer (SST) conductors CVV internally. Due to different temperature shrinking the two conductors are considered to be conductively decoupled from each other, with a remaining radiative coupling. Detailed investigations have been performed in [RD 57].

The thermally isolating harness lengths are defined between the following I/F points, see Figure 4.9-1:

- at SVM: all harness assumed to have SVM temperature at SVM / CVV strut I/F
- at CVV: all harness assumed to have CVV temperature at the CVV / tank suspension strap I/F. Thermal connection via connector brackets, additional thermal connections at CVV internal wall (if necessary)
- at TS1: thermal connection of SIH (except SPIRE JFET and HIFI coax harness) and CCH by means of "Stycast brackets", similar as done on ISO
- at TS2: thermal connection of SPIRE JFET harness by means of separate copper wires
- at OBA: thermal connection of PACS FPU, SPIRE FPU and HIFI FPU harness by means of "Stycast brackets".
- Furthermore, several other mechanical fixation points are necessary, like on the OBA (JFET and coax harness brackets), and generally on the tank suspension straps with lacing cords. Thermally, these interfaces are isolated by means of vespel washers or teflon/Goretex tape. Nevertheless, they are also considered in the TMM (see also Figure 4.3-1, nodes 291 – 298).

Thermal isolation length in general means the "free" length between the ends of harness thermal connection sections, e. g. between the CVV and the TS 1; the harness routing length between CVV connector brackets and the tank suspension straps is not taken as thermal isolating length, which is a conservative assumption.

The thermal contact conductance across a "Stycast bracket" is estimated to 0.05 W/K per branch.

Internal Harness (SIH)	Node	from	to	Length (1)	Average Dissip. at 77K	Spec Mode Dissip. at 77K	Phot Mode Dissip. at 77K	Stainl. St.	Brass	Silver	PTFE
				m	mW/m	mW/m	mW/m	mm ²	mm ²	mm ²	mm ²
PACS FPU	9101-9151, 9201-9228	CVV TS1 OBP	TS1 OB FPU	0.228-0.3 0.391-1.366 0.340-0.655	4.32	19.9	6.03	37.594	5.1	-	367
SPIRE FPU	9321-9331, 9341-9348	CVV TS1 OBP	TS1 OB FPU	0.3 0.636-0.723 0.327-0.378	1.186	7.116	1.217	11.068	6.216	-	103
SPIRE JFET-P (5)	9301-9311, 9361-9377	CVV TS2 (4)	TS2 (4) JFET-P	0.165-0.300 0.493-0.617	0.034	0	0.202	40.792	0.914	-	318
SPIRE JFET-S (5)	9381-9388	CVV TS2 (4)	TS2 (4) JFET-S	0.222-0.230 0.666-0.689	0.007	0.043	0	13.306	0.594	-	92
HIFI FPU	9401-9491	CVV TS1 OBP	TS1 OB FPU	0.236-0.3 0.383-0.394 0.385-1.272	4.55	HIFI on: 13.66		10.805	6.014		123
Coax (4x); ELSPEC type JS 50141	9501-9510, 9551-9560	CVV OBP	OBP FPU	0.788-1.227 (2) 0.185-0.414 (2)				4 x 3.08	CuBe: 4 x 0.653	4 x 0.034 (3)	4 x 6.34

- (1) thermally isolating length
- (2) Coax bundle mounted on CVV/OBP via 3 isolating vespel standoffs, resp.; A/I = 3 x 3.0 mm to CVV, A/I = 3 x 6.4 mm to OBP
- (3) equal to 11.7 microns silver coating thickness, measured by ASED; for detailed information see [RD 57]
- (4) JFET harness thermally linked to TS2 via copper wires; isolated mounting on OBP (vespel washers under stycast brackets)
- (5) JFET harness partly modelled in GMM, see Figure 4.3-3

Table 4.9-2: CVV Internal SIH Data for PACS, SPIRE and HIFI

External Harness (SIH)	Node	from	to	Length (1)	Average Dissip. (2)	Spec Mode Dissip. (2)	Phot Mode Dissip. (2)	Stainl. St.	Brass	Cu	Silver	Mang anin	PTFE
				m	mW/m	mW/m	mW/m	mm ²	mm ²	mm ²	mm ²	mm ²	mm ²
PACS FPU	9011-9096	SVM	CVV	1.5 - 2.0	2.9	8.21	9.17	37.536	5.132	-	-	17.517	367
SPIRE FPU		SVM	CVV	1.44-2.0	1.96	11.8	2.43	9.646	6.019	-	-	12.1	107
SPIRE JFET-P		SVM	CVV	1.44-2.0	0.0567	0	0.34	28.864	2.942	-	-	26.21	270
SPIRE JFET-S		SVM	CVV	1.44-2.0	0.0475	0.285	0	8.416	1.028	-	-	6.048	83
HIFI FPU		SVM	CVV	1.67-2.0	7	HIFI on: 21			30.73	6.014	-	21.02	8.64
Coax (4x) ELSPEC type JS 50141		SVM	CVV	2	-			4 x 3.08	-	CuBe: 4 x 0.653	4 x 0.034 (3)	-	4 x 6.34
HIFI LOU [RD 33] (4)	4301-4316	SVM	LOU	1.95-2.03	49.4	LOU on: 148.2		7.72	0.914	76.4	-	24.31	106

(1) thermally isolating length

(2) with the exception of LOU harness all dissipation values are valid for 293 K, dissipation at lower temperature expected to be lower

(3) equal to 11.7 microns silver coating thickness, measured by ASED; for detailed information see [RD 57]

(4) attached to CVV via GFRP support tubes, see also Figure 4.8-3

Table 4.9-3: CVV External SIH Data

Internal Harness (CCH)	from	to	Length (1)	Dissip.	Stainl. St.	Brass	PTFE
			m	mW	mm ²	mm ²	mm ²
CCH to HOT & HTT	CVV low. CB TS1	TS1	0.24-0.3	296 (2)	2.23	3.05	34.2
		low. SFW	0.67-1.55	437 (2)	2.23	3.05	34.2
	low. SFW	HOT	0.1	547 (2)	0.55	0.91	9.1
	low. SFW	HTT	0.4	0	1.48	2.12	23.4
CCH to OBP	CVV upp. CB TS1 upp. SFW	TS1	0.23-0.3	0	1.98	-	18
		upp. SFW	0.65-1.9		1.62		14.7
		OBP	0.5		1.62		14.7

(1) thermally isolating length

(2) only at the end of Launch Autonomy; dissipation of HOT depletion heater harness, providing depletion heater with 10 W (comp. to Figure 6.2-1)

Table 4.9-4: CVV Internal CCH Data

External Harness (CCH and Telescope)	Node	from	to	Length (1)	Dissip.	Stainl. St.	Brass	Cu	Manganin	PTFE
				m	mW	mm ²	mm ²	mm ²	mm ²	mm ²
CCH to CVV lower CB	9011-	SVM	CVV low. CB	0.99-1.68	0	2.384	3.0	-	5.3	35.6
CCH to CVV upper CB	9096	SVM	CVV upp. CB	1.46-1.89	0	2.352	-	-	1.992	21.3
CCH to CVV structure/VL		SVM	CVV	1.0-1.06	0	1.12	1.224	2.4	7.02	16.2
CCH to Cover	9921- 9924	SVM	Cryostat baffle conn. bracketö	3.5		0.128	2.856	-	1.968	8.76
Telescope sensor & heater via CVV	8608- 8620	SVM	CVV (3)	1.9-3.5	13.5 (2)	0.384	-	8.0	3.24	11.17
		CVV (3)	TMS conn. bracket	1.7-3.3						
CCH to SVM Thermal Shield		SVM	SVM Shield	0.3 - 0.5	0	0.128	-	0.6	0.648	1.18
CCH to Solar Array		SVM	Solar Array	0.5			-	34.5	-	-

(1) thermally isolating length

(2) only during telescope decontamination; comp. to LEOP/cool down section (pages 105-107)

(3) fixed along CVV via 11 glass/epoxy brackets (clickbond), total A/I = 35.2 mm

Table 4.9-5: CVV External CCH Data

4.10 HERSCHEL Solar Array and Sunshade with Struts

The HERSCHEL Solar Array and Sunshade (HSS) is split in two parts, the upper part is the Sunshade (SSD), providing the shade mainly for the telescope and the lower part is the Solar Array (SA), which provides shading for the CVV and the electrical power. The SA +Z side therefore is covered with solar cells and the SSD +Z side is covered with OSRs. The rear side (-Z side) of the HSS is covered with high efficient MLI. The HSS nodal breakdown including struts is shown in Figure 4.10-1 and Figure 4.10-2 and the corresponding thermally relevant data are listed in Table 4.10-1.

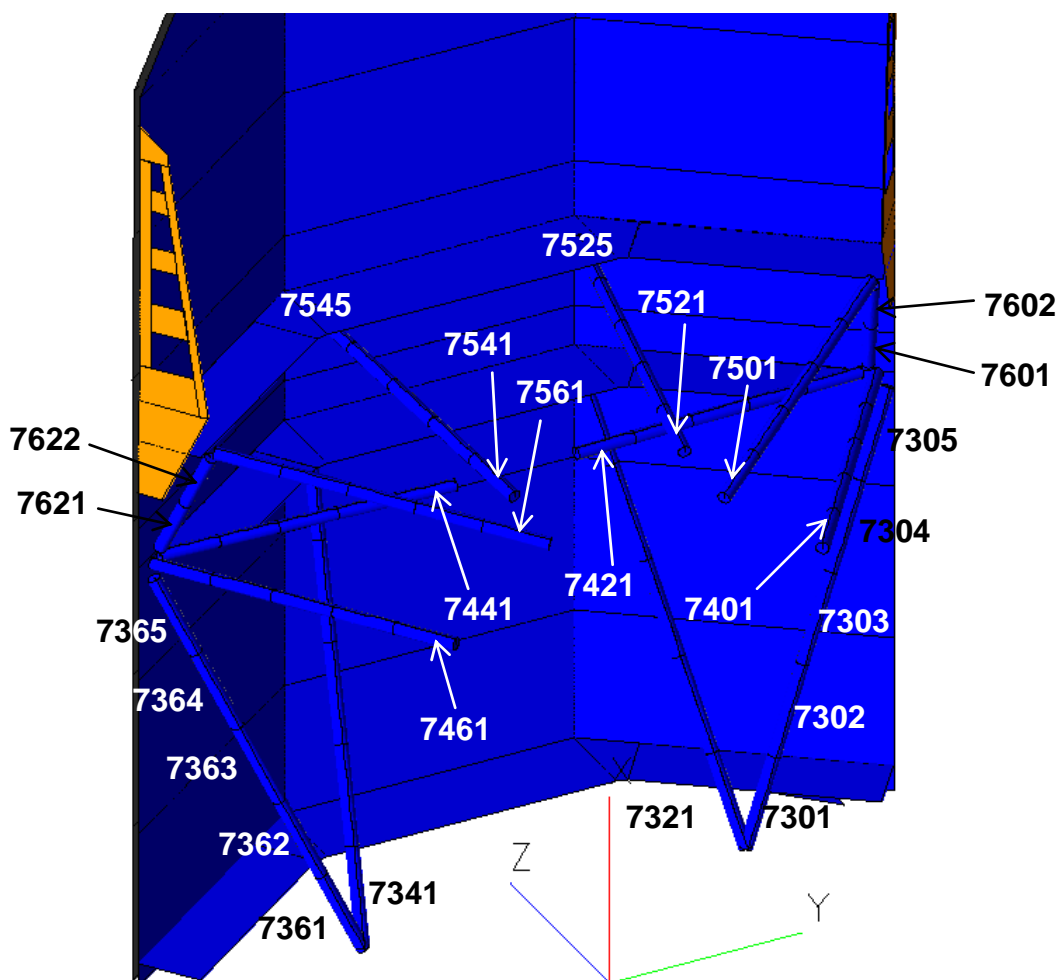

Figure 4.10-1: HSS Struts Nodal Breakdown

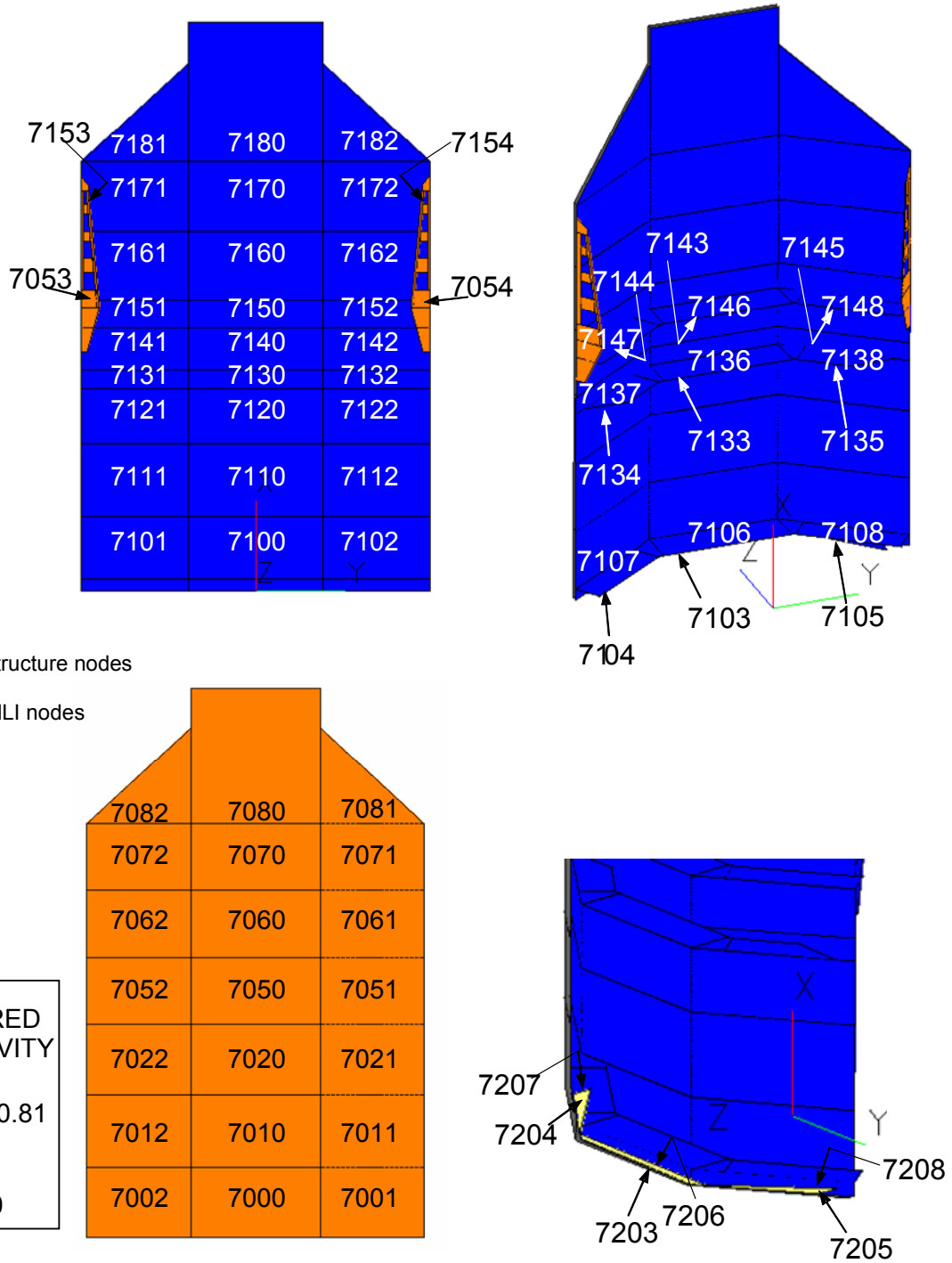

Figure 4.10-2: HSS Nodal Breakdown

Item	Node	Material / Components	Mass	Size	Unit Level Requirement	Solar Absorpt.	IR Emiss.	Remark
Solar Array Panels	7000-7022	Solar Cells with cover glass and harness CFRP skins (M55J) * Adhesive for HC Al Honeycomb (16 kg/m ³)	1.6 kg/m ² 0.83 kg/m ² 0.3 kg/m ² 0.8 kg/m ²	2 x 0.3 mm thick 50 mm thick		0.915 [RD 18] -1200 W during Operation	0.81 [RD 18]	
	7401-7465 7301-7365	GFRP struts incl. MLI to CVV M55J CFRP struts incl. MLI with Ti end fittings (Ti6AlV4) to SVM Ti tubes to SVM Power harness to SVM		A/L = 2.5 mm GFRP in total A/L = 1.4 mm M55J with A/L = 12.9 mm Ti in serial 0.04 W/K 34.5 mm ² Copper, 0.5 m length	R-SS-0330 [RD 25]	0.13 0.13	0.15 0.15	[RD 37], [RD 38] [RD 37]
Solar Array Panels MLI	7100-7132							
Solar Array Stiffening Frame MLI upper	7133-7138	27 layers (1+7+18+1); IR specularity 0.80	0.65 kg/m ²		R-EXM-430 [RD 28]	0.13	0.05	
Solar Array Stiffening Frame MLI lower	7103-7108							
Solar Array-SVM Closure MLI	7203-7208	27 layers (1+7+18+1); IR spec. 0.8 -x side: ITO FEP; IR spec. 0	0.65 kg/m ²		R-EXM-430 [RD 28]	0.13 0.14	0.05 0.75	+x side -x side
Sunshade Panels	7050-7082	OSR inclusive Adhesive CFRP skins (M55J) Al Honeycomb (16 kg/m ³)	1.0 kg/m ² 0.83 kg/m ² 0.8 kg/m ²	2 x 0.2 mm thick 50 mm thick		0.20 0.10	0.84 0.84	EOL BOL
	7501-7565	GFRP struts incl. MLI to CVV Ti brackets/vespel washers to SA		A/L = 2.4 mm GFRP in total	R-SS-0330 [RD 25]	0.13	0.15	
Sunshade +Y Stiffen. Rib	7054					0.92	0.8	
Sunshade -Y Stiffen. Rib	7053					0.92	0.8	
Sunshade Panels MLI	7140-7142, 7150-7182	25 layers (1+7+6+10+1) IR specularity 0.80	0.65 kg/m ²		R-EXM-330 [RD 28]	0.13	0.05	
Sunshade +Y Rib MLI	7154							
Sunshade -Y Rib MLI	7153							
Sunshade Stiff Frame MLI	7143-7148							

Table 4.10-1: HSS related Items

4.11 SVM with Struts and SVM Thermal Shield

To calculate the radiative couplings of the HERSCHEL SVM/CVV GFRP struts to their environment all 24 struts have been modelled in the ESARAD geometry model, including the MLI around the struts.

Generally, struts covered in MLI are subdivided in 3 nodes, struts without MLI around are subdivided in 10 nodes (more refined due to "T⁴-law") in longitudinal direction. The strut MLI is subdivided additionally around the perimeter. An overview is given in Figure 4.11-1. Detailed figures showing the node distribution both for the SVM/CVV struts and their MLI are given in [RD 45], p. 58 - 62. The thermal design for each strut is summarised in Table 4.11-1.

The relevant conductive length for the thermal analysis is the total GFRP strut length minus the length of the sections where GFRP tube and the titanium end fitting overlap. The thermally relevant dimensions of the struts are summarized in Table 4.11-2.

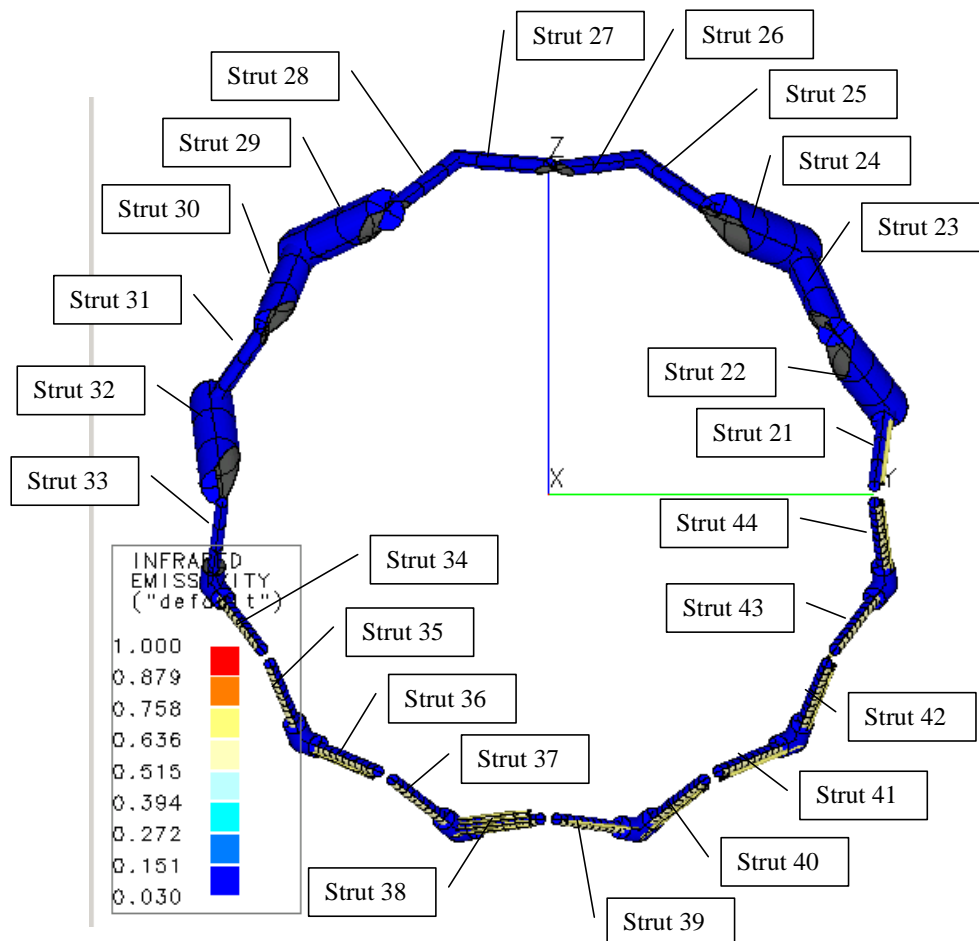

Figure 4.11-1: SVM/CVV Interface Struts (numbering as per CASA I/F drawings)

Strut No. as defined in CASA I/F drawings [RD 51]	Strut No. as used in TMM and GMM	Thermal Design
22	19	Completely wrapped in MLI; 9-layer VDA Kapton MLI, Type "STRUT_7e" as defined in [RD 50], p. 5
23	20	
24	21	
25	22	
26	23	
27	24	
28	1	
29	2	
30	3	
31	4	
32	5	
21	18	Struts completely taped with VDA/Kapton around the perimeter; Struts covered with MLI only at the SVM I/F (typically up to a height of 10 cm above the SVM I/F); MLI Type "STRUT_7e" as defined in [RD 50], iss. 3.0, p. 5
33	6	
34	7	Half perimeter facing the S/C centre taped with VDA/Kapton; Half perimeter facing deep space left uncoated (glass-fibre/epoxy); Struts covered with MLI only at the SVM I/F (typically up to a height of 10 cm above the SVM I/F); MLI Type "STRUT_7e" as defined in [RD 50], iss. 3.0, p. 5
35	8	
36	9	
37	10	
38	11	
39	12	
40	13	
41	14	
42	15	
43	16	
44	17	

Table 4.11-1: SVM/CVV Interface Struts – Numbering and Thermal Design

The SVM Thermal Shield is subdivided into 5 nodes and the SLI screen on top of the SVM Shield is subdivided accordingly, see Figure 4.11-2. The whole SVM Shield has a high IR reflectivity (VDA Kapton), apart from the +/-Y tips of the SVM Shield panel that are coated with ITO VDA Kapton, which is an outcome of a detailed barbecue analyses [RD 17].

The struts supporting the SVM Thermal Shield are implemented by conductive couplings between SVM and SVM Thermal Shield.

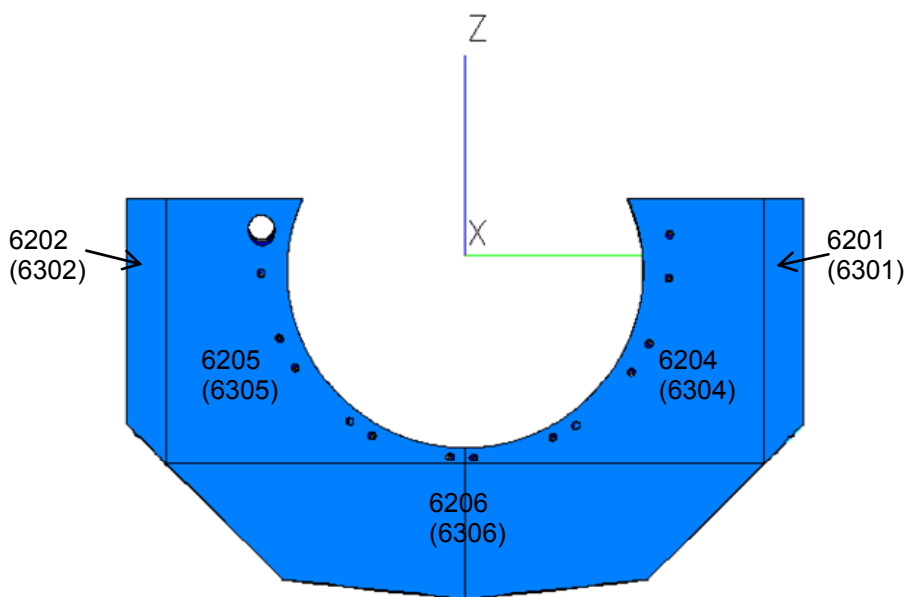
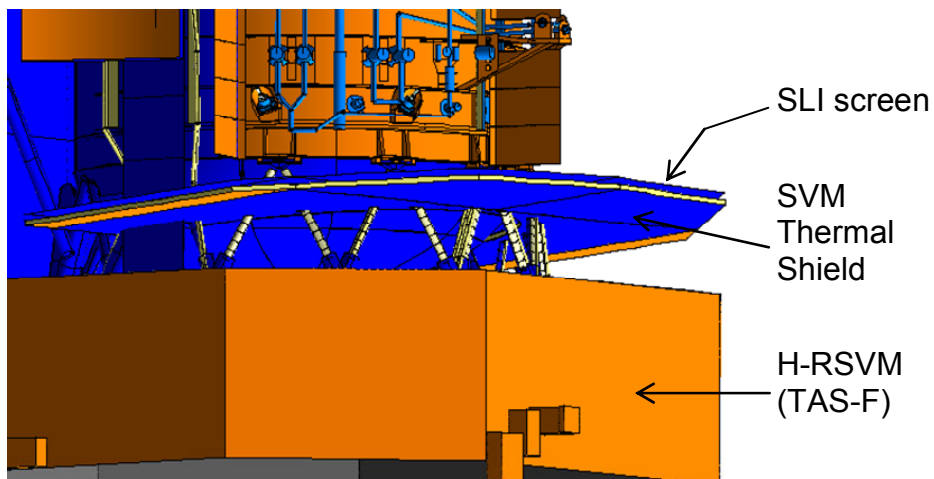

Nodes in parenthesis refer to SLI screen

Figure 4.11-2: H-RSVM, SVM Thermal Shield and SVM/CVV Struts

Item	Node	Material / Components	Mass	Size	Unit Level Requirement	Solar Absor.	IR Emiss.	Remark
SVM Module	60XX,61XX 6020-6024 6051-6058, 6101-6108	H-RSVM model, provided by TAS-F Boundary Nodes (conductive) SVM top MLI				0.15	0.05	[AD 07], [AD 08]
SVM/CVV struts	6501-6733	GFRP strut tubes Ti fittings for GFRP tubes		A/L = 13.35 mm GFRP in total (24x D=35 x 2.1 mm, l=390 mm)	R-SS-0330 [RD 25]	0.7	0.6	[RD 37], [RD 38]
SVM/CVV struts MLI	65011-67322	9 layers VDA Kapton				0.13	0.03	[RD 50]
SVM Thermal Shield	6201-6206	CFRP T300 face sheets, VDA Kapton Foil on +/-X side (90% specularity) +/-Y tips on -X side ITO coated VDA Kapton Al Honeycomb (32 kg/m ³) Panel rim Kapton taped		2 x 0.5 mm thick 19 mm thick	R-STS-0180 [RD 26] R-STS-0190 [RD 26]	0.3 0.44	0.05 0.77	
		GFRP strut tubes to SVM structure Ti fittings for GFRP tubes		A/L = 3.679 mm GFRP in total	R-STS-0230 [RD 26]		0.05	[RD 37], [RD 38]
SVM Thermal Shield SLI screen	6301-6306	1 layer VDA/Kapton/VDA IR specularity 0.80 both sides		~ 30 mm distance to SVM Thermal Shield	R-EXM-630 [RD 28]	0.13	0.05	

Table 4.11-2: SVM and SVM Shield related Items

5 Material Properties

Note: All material properties tested on Herschel samples and components are compiled in [RD 35]. All other references used for material properties are listed in Section 5.6 of this chapter (i.e. not in Section 2).

5.1 MLI Thermo-Optical Properties and Performance Data

CVV Internal MLI

The heat flux approximations and the thermal performance parameters derived in [RD 36] are compiled in Table 5.1-1 for the "Herschel-type" MLI. This MLI is used for the Thermal Shields MLI. The corresponding values for the "ISO-type" MLI are taken from /1/ and are summarized in Table 5.1-2. The ISO MLI data are used for the HTT and HOT MLI.

The heat fluxes are calculated for different boundary temperatures T_H and T_C . Herewith T_H corresponds to the temperature of the outermost MLI blanket layer while T_C corresponds to the thermal shield temperature the MLI blanket is attached to.

	$q = (a (T_H + T_C)/2 + b) (T_H - T_C) + \epsilon \sigma ((T_H^4 - T_C^4))$		
	a	b	ϵ
10-layer MLI	8.720E-06	2.353E-05	0.00395
20-layer MLI	4.360E-06	1.177E-05	0.001975

Table 5.1-1: Derived MLI Performance Data for Herschel Type MLI

	$q = h (T_H - T_C) + \epsilon \sigma ((T_H^4 - T_C^4))$	
	h (W/m ² K)	ϵ
10-layer "ISO-type" MLI	3.50E-04	0.0030

T_H = "hot" temperature of outermost blanket layer

T_C = "cold" temperature of innermost blanket layer = identical to thermal shield temperature

Table 5.1-2: Derived MLI Performance Data for ISO Type MLI /1/

Degradation factors of integrated MLI have been evaluated in detail for the different MLI sections. The derivation of those factors is also described in [RD 36]. It should be noted that worst-case assumptions have been used for the individual contributions to the total degradation factor, leading to a strictly conservative MLI performance presentation in the TMM. An overview of all CVV internal MLI performance data used in the TMM is compiled in Table 5.1-3.

MLI on	Layers	radiative emissivity (ϵ_{rad})	linear conductance H [W/m ² K]	Integration Factor		emissivity of ext. layer (ϵ_{ext})	specul. of ext. layer (ρ_{ext})
				Orbit	Ground		
HTT	10	0.003	3.5 E-4	2	2	0.05	0
HOT	10	0.003	3.5 E-4	1	1	0.05	0
TS 1 upper bulk	10	0.00395	H(T) *	1.86	2.57	0.05	0
TS 1 upper cylinder	10	0.00395	H(T) *	2.60	4.05	0.05	0
TS 1 lower cylinder	10	0.00395	H(T) *	1.50	1.99	0.05	0
TS 1 lower bulk	10	0.00395	H(T) *	2.43	2.75	0.05	0
TS 2 upper bulk	20	0.001975	H(T) *	1.66	1.66	0.05	0
TS 2 upper cylinder	20	0.001975	H(T) *	2.05	2.03	0.05	0
TS 2 lower cylinder	20	0.001975	H(T) *	1.42	1.43	0.05	0
TS 2 lower bulk	20	0.001975	H(T) *	1.83	1.80	0.05	0
TS 3 upper bulk	20	0.001975	H(T) *	1.64	1.63	0.05	0
TS 3 upper cylinder	20	0.001975	H(T) *	2.09	2.05	0.05	0
TS 3 lower cylinder	20	0.001975	H(T) *	1.55	1.53	0.05	0
TS 3 lower bulk	20	0.001975	H(T) *	1.60	1.58	0.05	0

*) see Table 5.1-1

Table 5.1-3: Overview on CVV Internal MLI Performance Data

CVV External MLI

The temperature-dependent performance of the external MLI is defined in table arrays within the file matdatab.d. These tables include overall heat transfer coefficients [W/(m²K)] dependent on the temperatures TEXT and TINT of the outermost and innermost blanket layer. These heat transfer coefficients were calculated with the help of dedicated ESATAN models prepared for each type of MLI. In these models each foil of the relevant MLI blanket is represented by a separate thermal node and the heat exchange between two adjacent foils is simulated by both, a temperature-dependent conductance GL(i, i+1) and a constant or temperature-dependent radiation heat exchange factor GR(i, i+1), depending on the type of the blanket.

GL(i, i+1) and GR(i, i+1) are based on mathematical approaches that have been correlated by calorimeter tests conducted at ESTEC for a Dacron-spacered XMM-type blanket (YCV/2248.BA) and a non-spacered embossed-Kapton type blanket (TOS-MCV/2438.BA). The calorimeter tests were conducted at five different temperature pairs T_innermost foil / T_outermost foil. The lowest temperature was 83 K which is very close to the Herschel in-orbit CVV temperature.

Detailed information on the various blanket/layer compositions of the different components, the corresponding thermal performances and the analytical background is given in [RD 43], [RD 46] and [RD 50].

Note that the SVM thermal shield now is equipped with a single Kapton foil (VDA on both sides), which is mounted on the +x side via standoffs in a distance of about 30 mm (see also Figure 4.11-2).

MLI on	Layers	Type	emissivity of external layer (ϵ_{ext})	IR specul. of external layer (ρ_{ext})	Remark
CVV, Cryostat Baffle	41	CVV_7embossed – CVV5 - CVV5 – CVV5; Kapton VDA, Mylar VDA	0.05	0.80	[RD 50]
LOU	41	CVV_7embossed – CVV5 - CVV5 – CVV5; Kapton VDA, Mylar VDA	0.05	0.80	[RD 50]
Sunshade	25	SSD_7embossed; Kapton VDA, Mylar VDA	0.05	0.80	[RD 50]
Solar Array	27	SSH_7embossed; Kapton VDA	0.05	0.80	[RD 50]
SVM Shield +X	1	SL4; VDA/Kapton/VDA	0.05	0.80	SLI screen [RD 50]
SVM Struts	9	STRUT_7embossed; Kapton VDA	0.03	0	[RD 50]
SVM Top	n.a.	n.a.	0.05	0	Provided by TAS-I [AD 07], [AD 08]
Telescope Mounting Structure	14	CVV_7embossed; Kapton VDA	0.05	0.80	[RD 50]
Telescope Orbit Decontamination	2-3	n.a.	0.025 0.05	0.80 0.80	2-screen concept; provided by ASEF [RD 29]

Table 5.1-4: Overview on CVV External MLI Performance Data

5.2 Thermal Conductivity Data

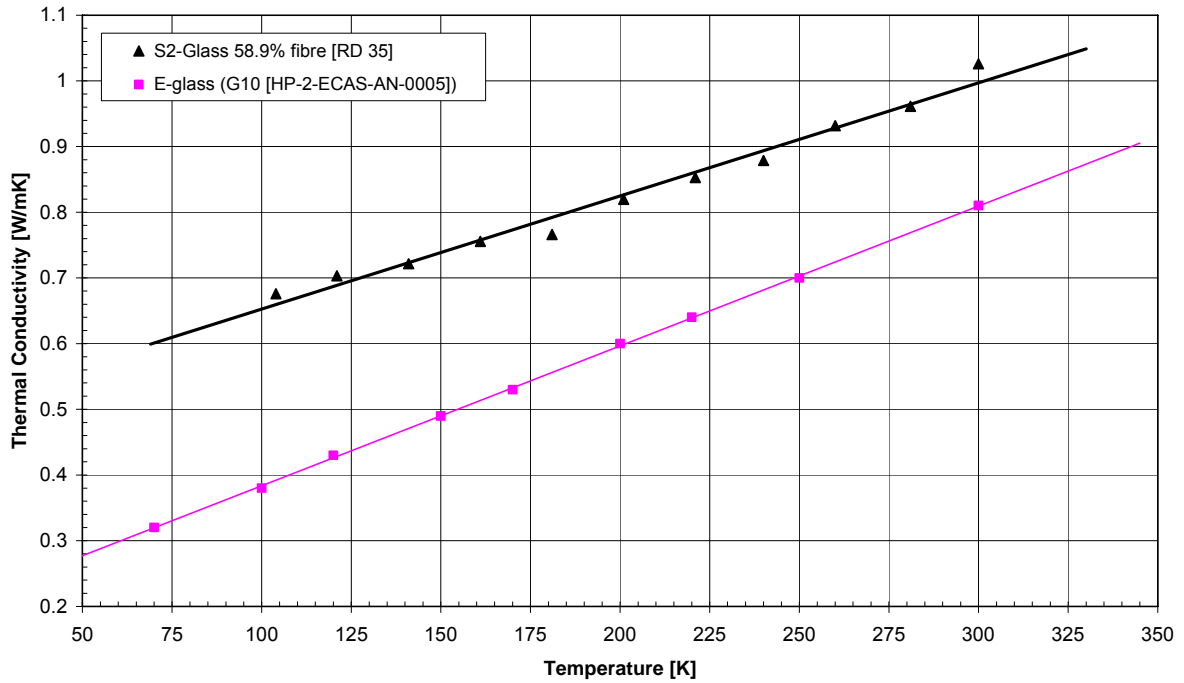

Figure 5.2-1: Thermal Conductivity of S2-Glass and E-Glass GFRP Struts

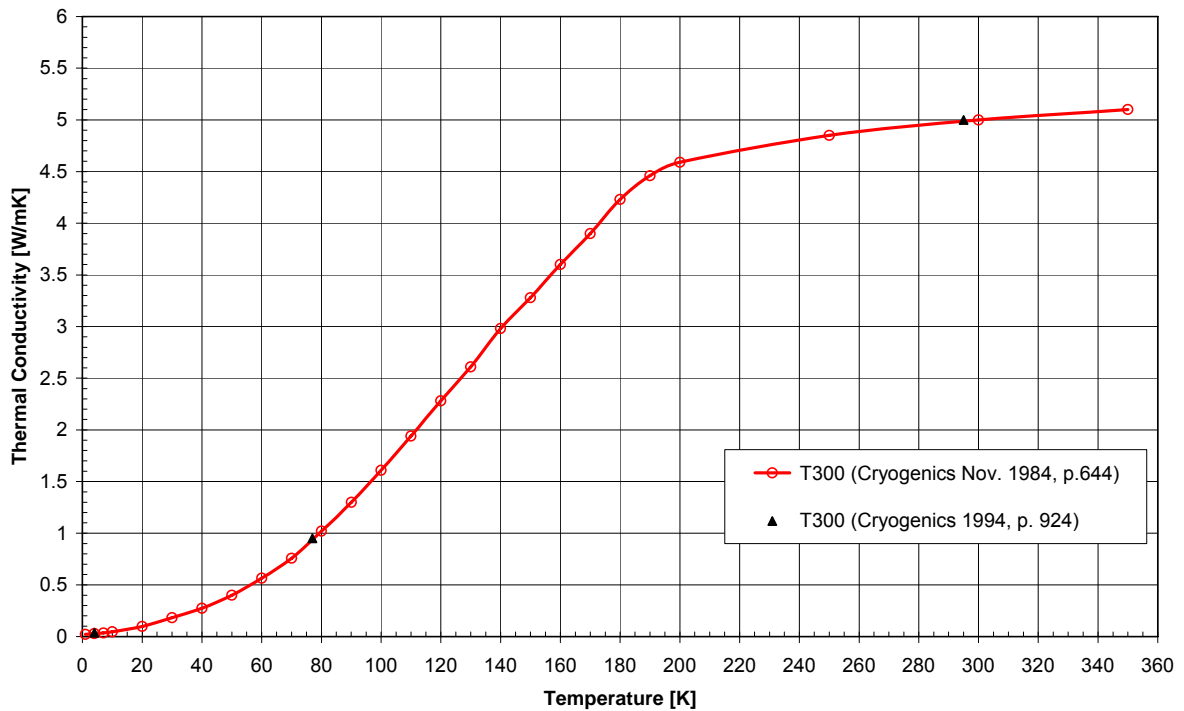

Figure 5.2-2: Thermal Conductivity of CFRP T300 Struts

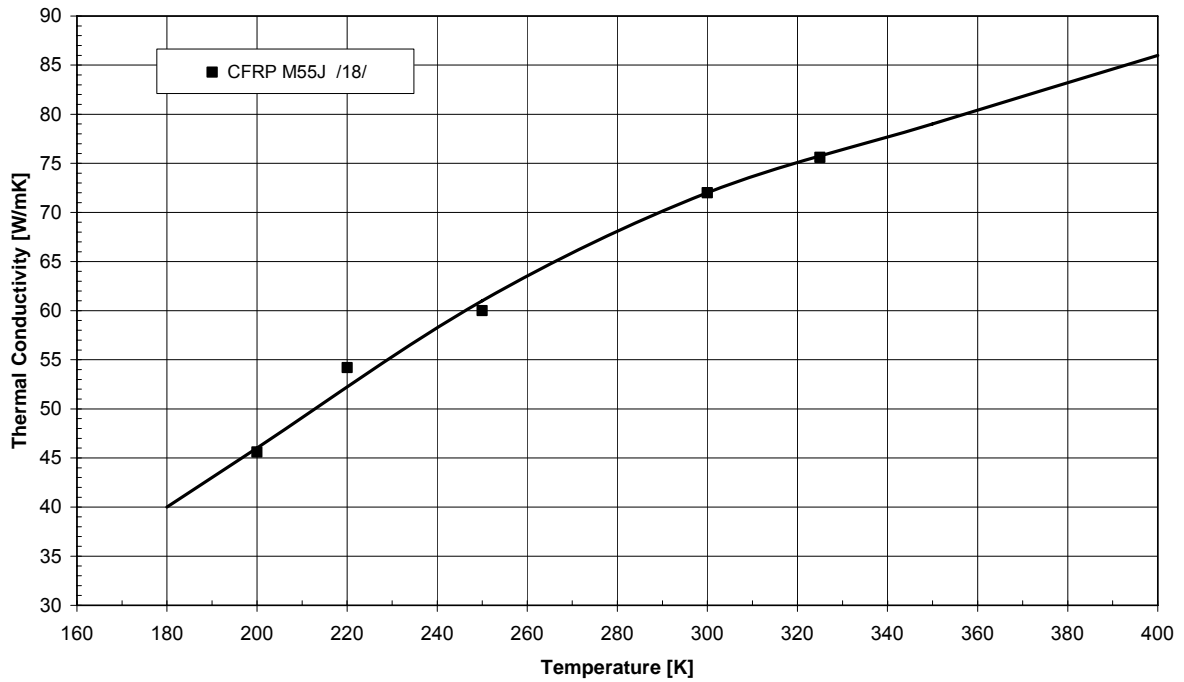

Figure 5.2-3: Thermal Conductivity of CFRP M55J Struts

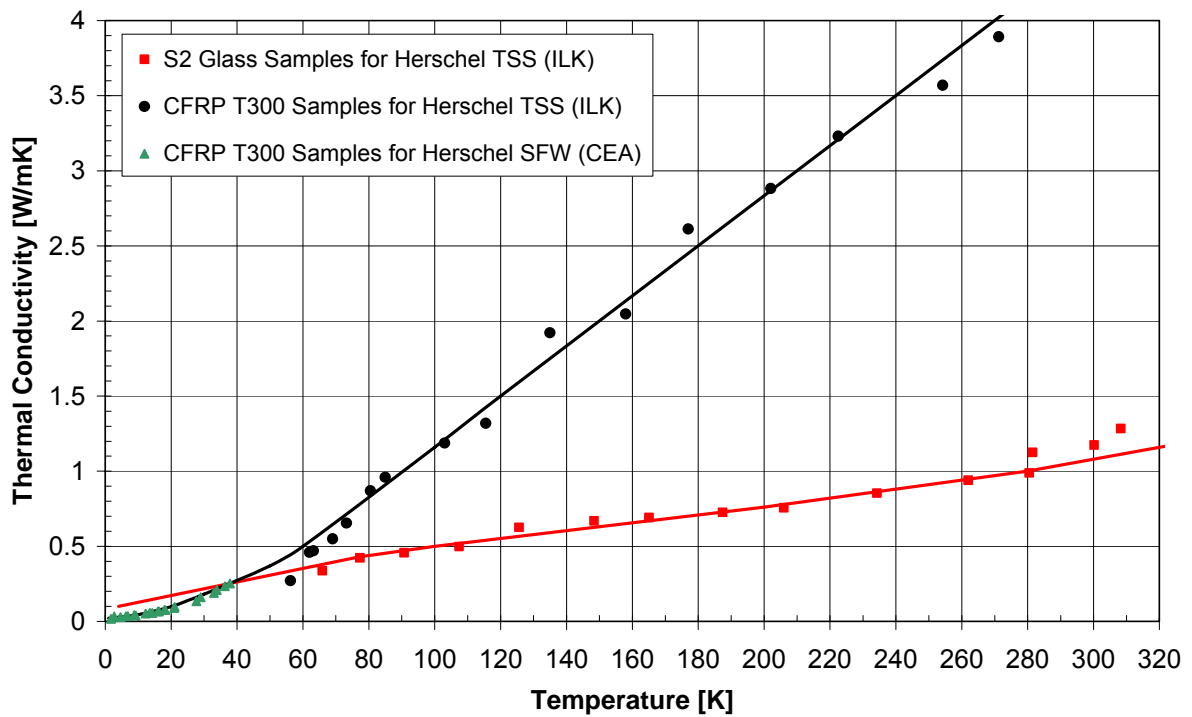

Figure 5.2-4: Thermal Conductivity of CFRP T300 and GFRP (S-glass) Tank Suspensions [RD 35]

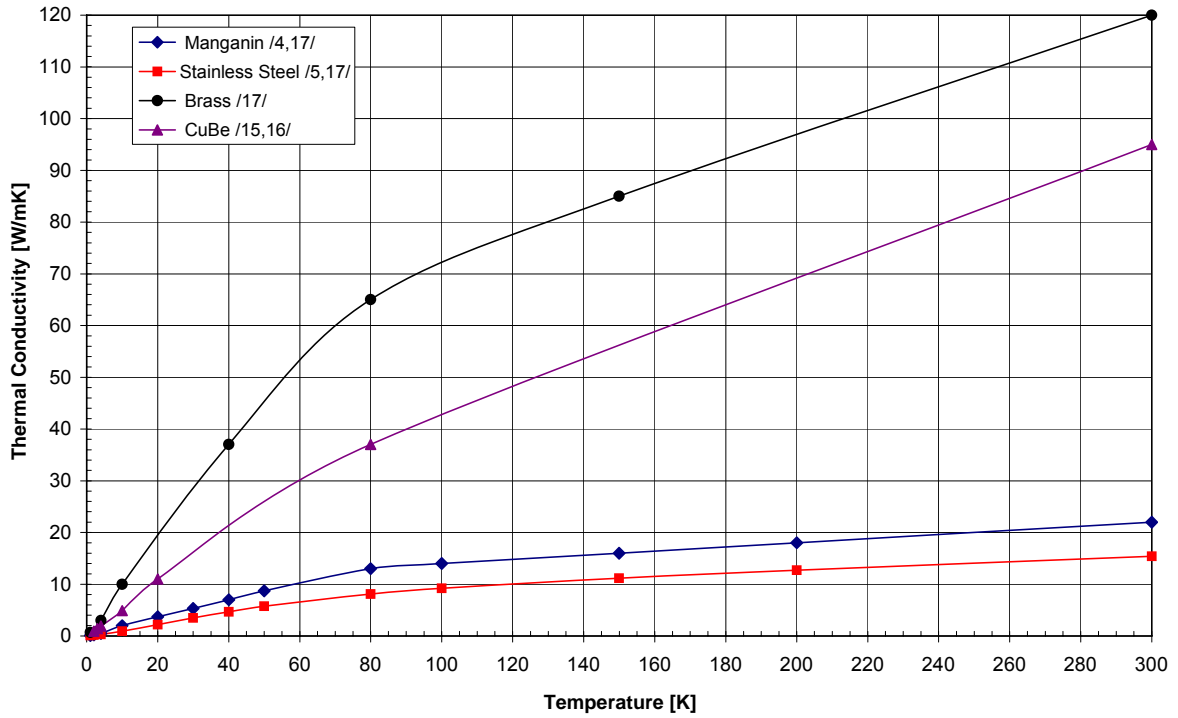

Figure 5.2-5: Thermal Conductivity of Harness Wires

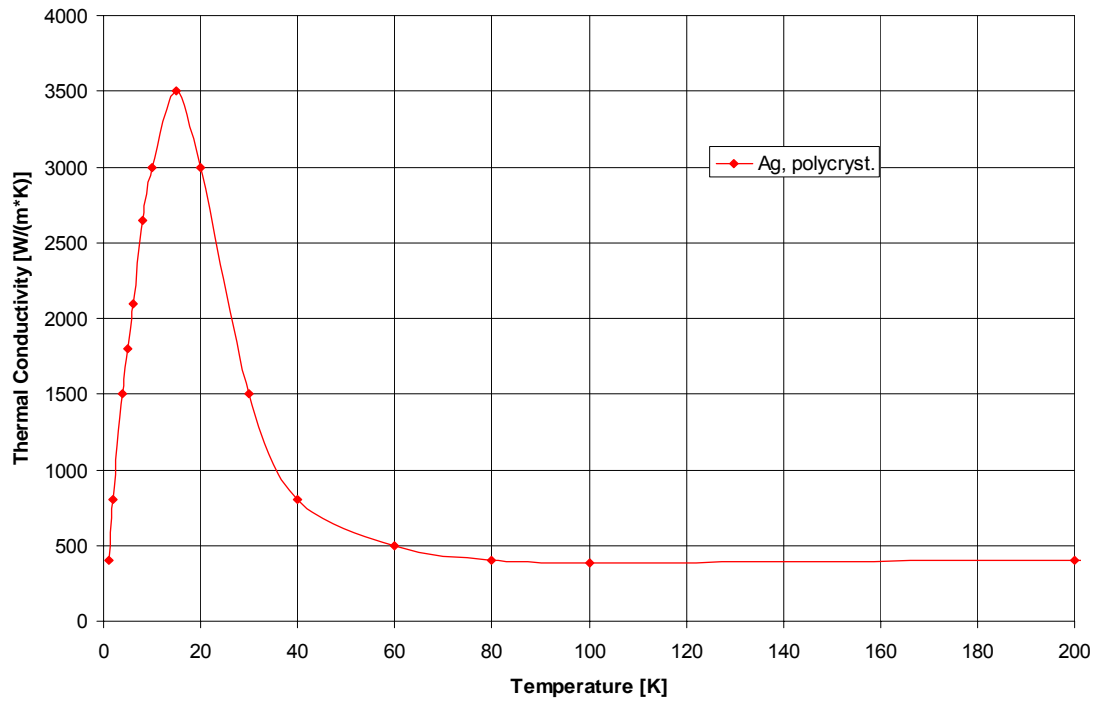

Figure 5.2-6: Thermal Conductivity of Coax Coating

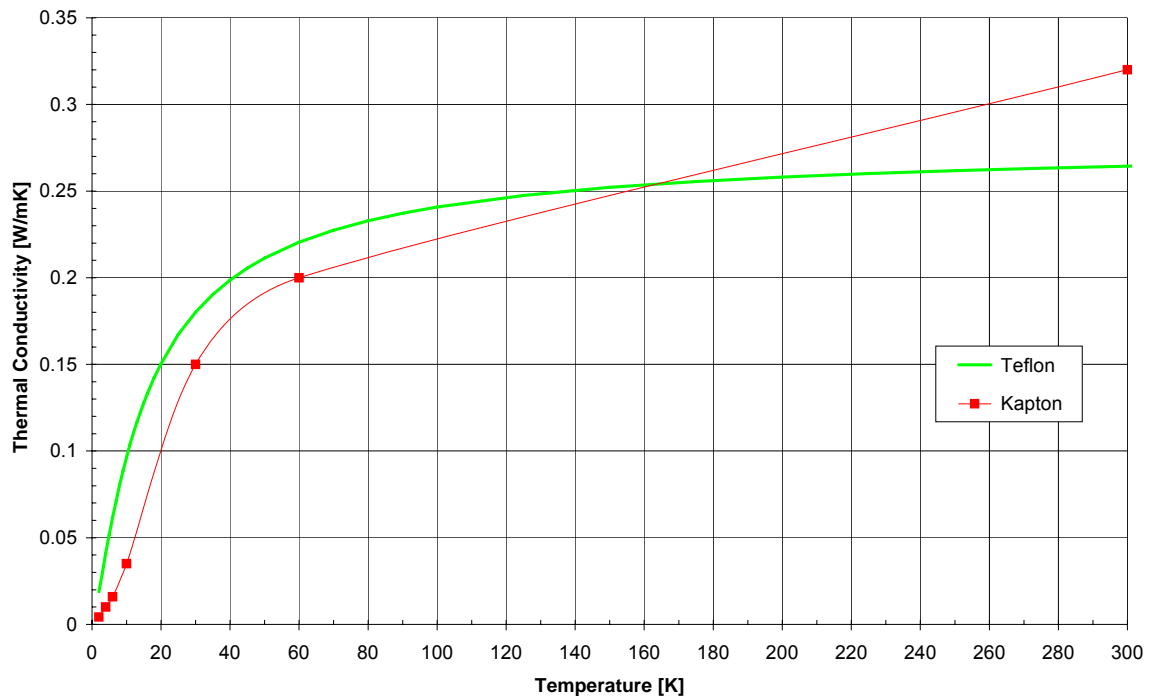

Figure 5.2-7: Thermal Conductivity of Harness Wire Insulation Materials /14/

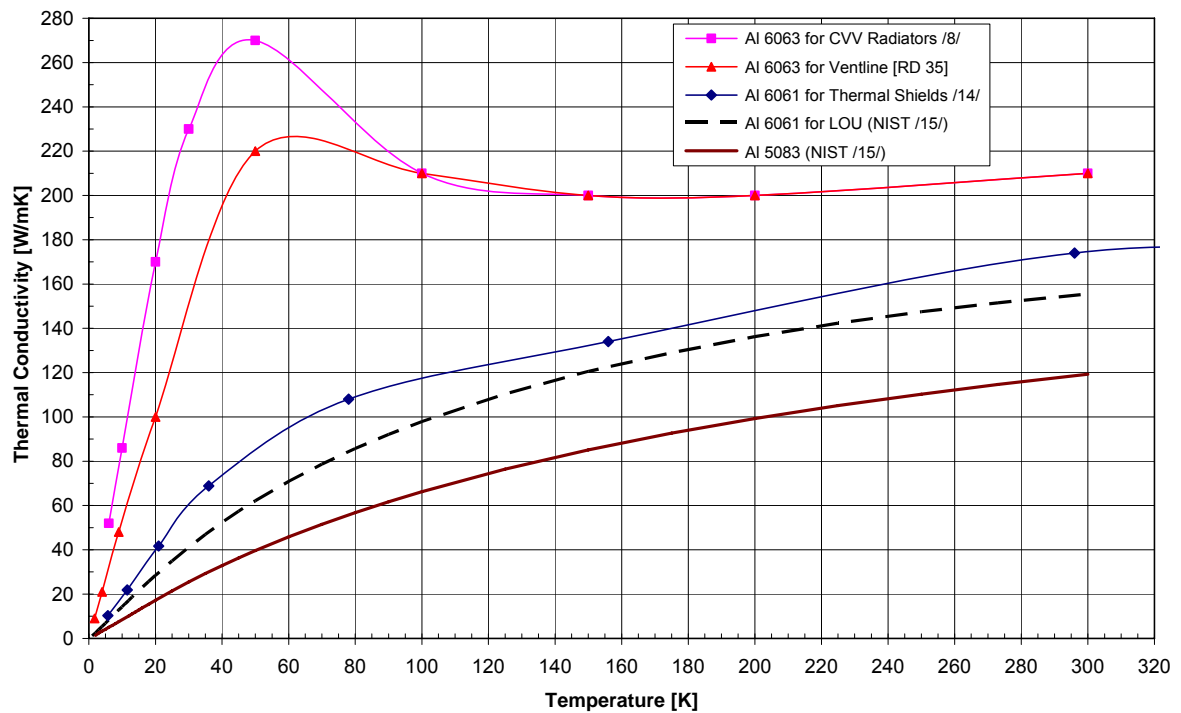

Figure 5.2-8: Thermal Conductivity of Aluminium Alloys

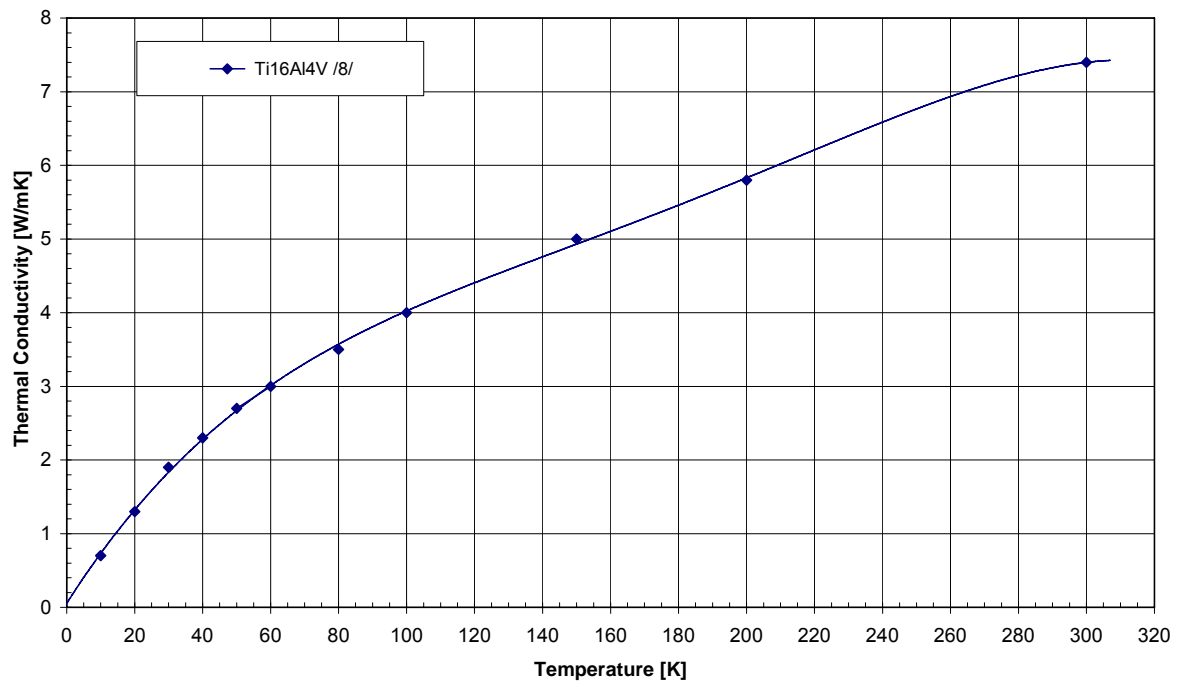

Figure 5.2-9: Thermal Conductivity of Titanium Alloy Ti6Al4V

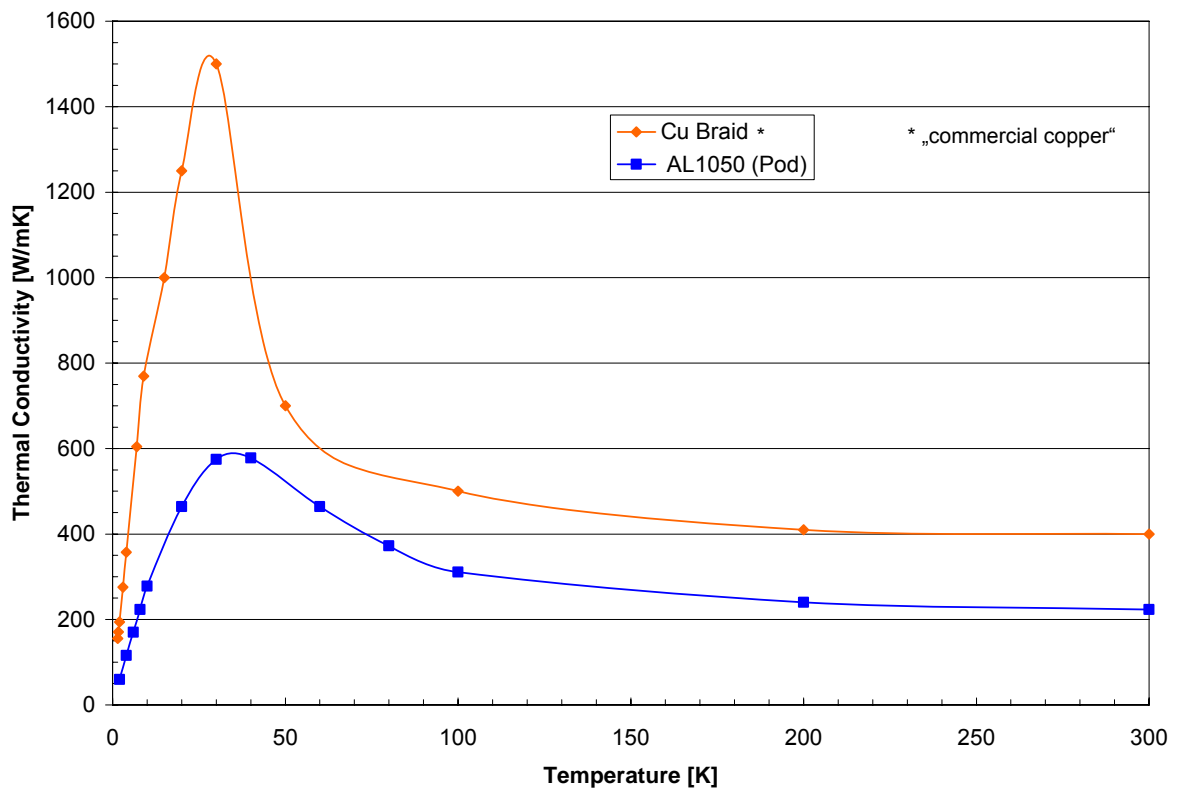

Figure 5.2-10: Thermal Conductivity of Thermal Link Materials [RD 35]

5.3 Thermal Contact Conductance Data

The thermal contact conductance data given in Figure 5.3-1 are related to 1 kN and 1 bolt. For calculating the total contact conductance of an interface the following contact forces are applied:

- 2000 N for each M4 bolt with Invar washer
- 3000 N for each M5 bolt with Invar washer
- 10000 N for each M8 bolt with Invar washer

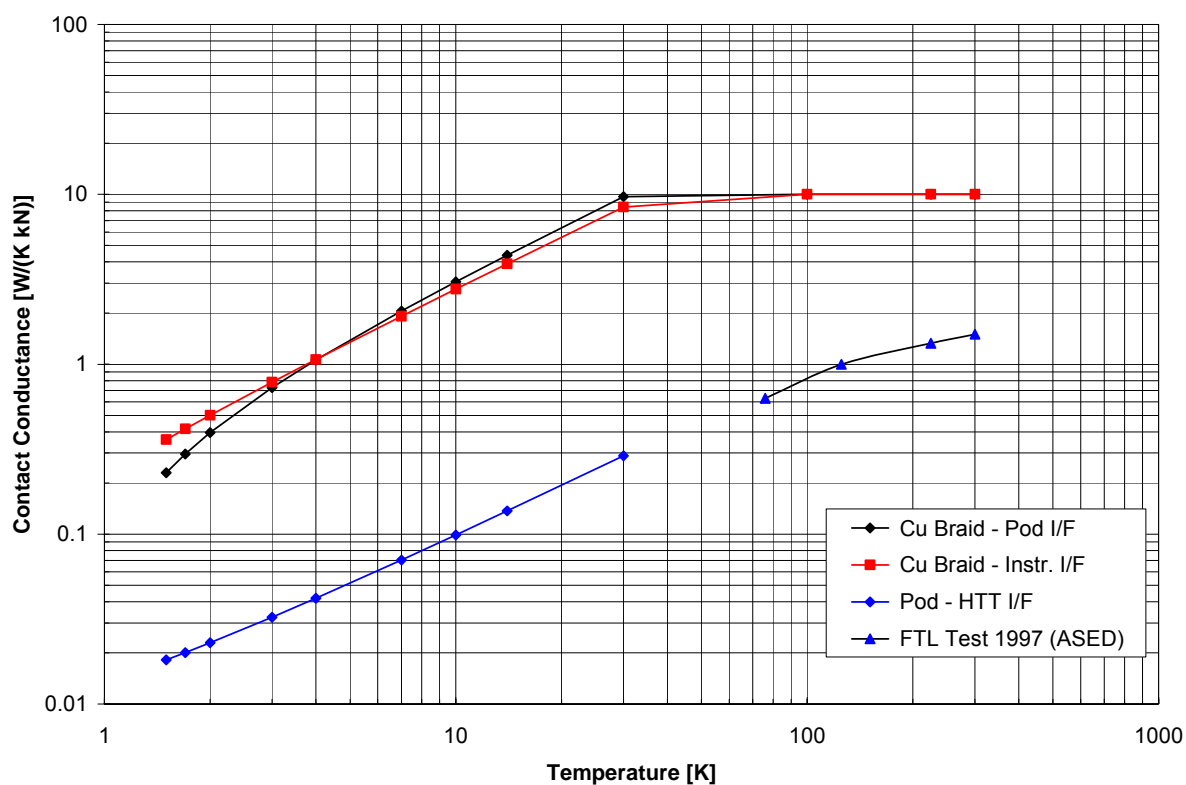

Figure 5.3-1: Thermal Contact Conductance of Thermal Link Interfaces [RD 35]

5.4 Specific Heat Capacity Data

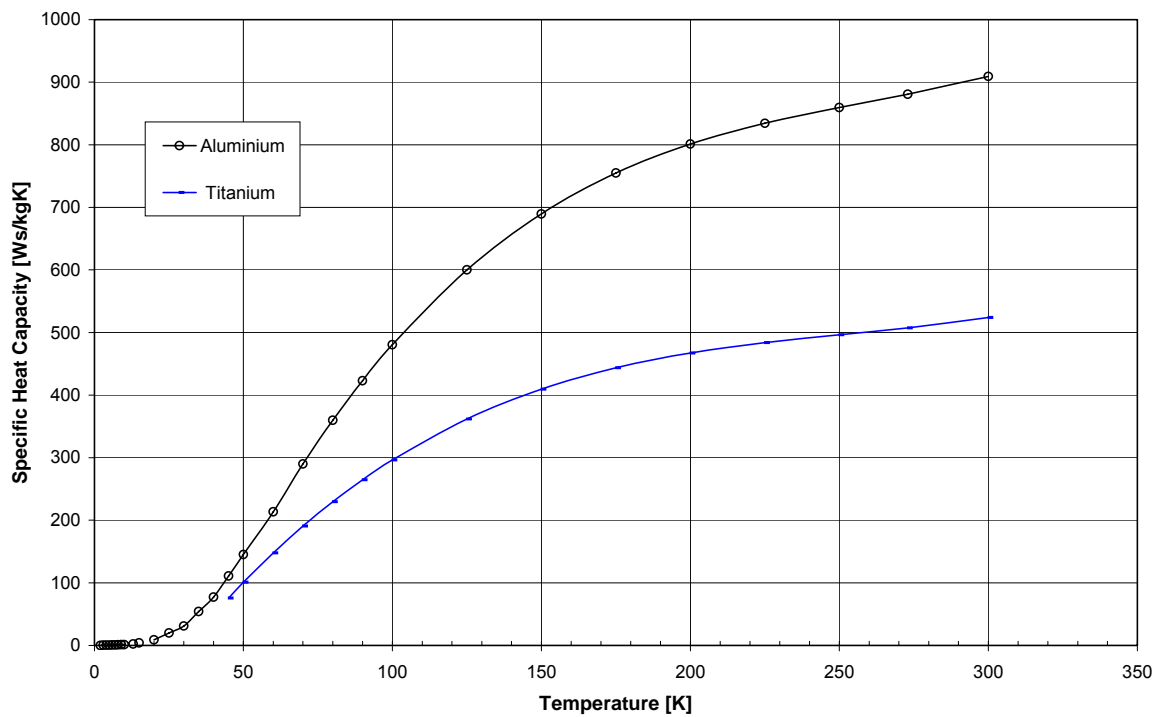

Figure 5.4-1: Specific Heat Capacity of Aluminium and Titanium /14/

5.5 Helium Properties

For the heat of vapourization of Helium different values are found in literature, see Figure 5.5-1. For the TMM calculations the data reported in Ref. /2/ are used.

The specific heat of the gas is 5.1966 kJ/kg/K (almost constant versus temperature).

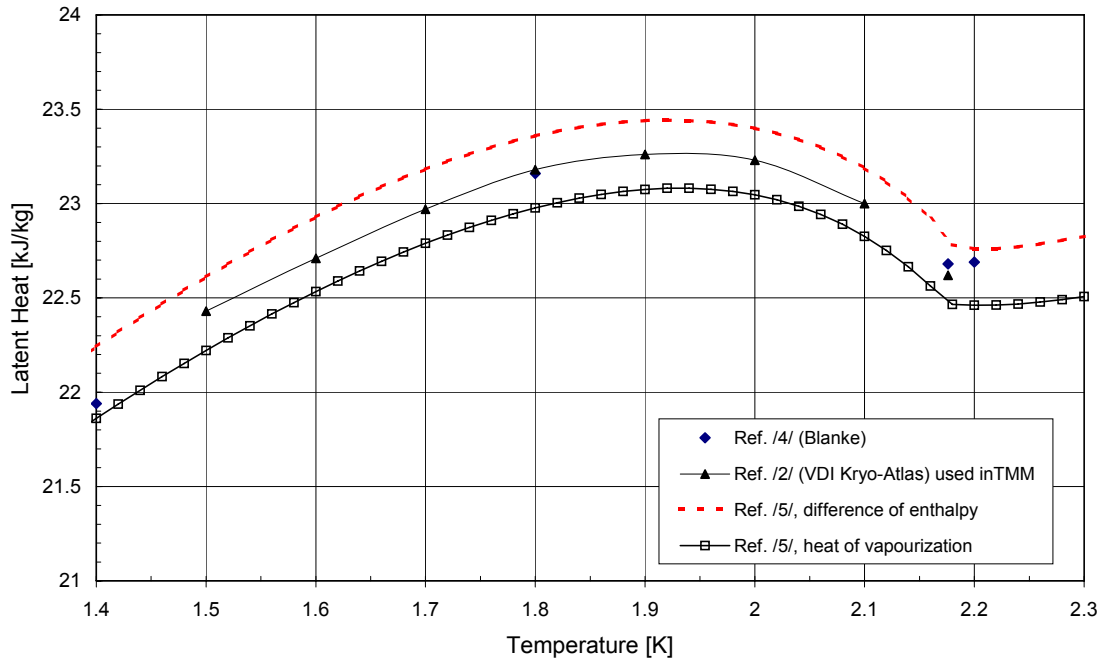

Figure 5.5-1: Heat of Vapourization of Helium 4

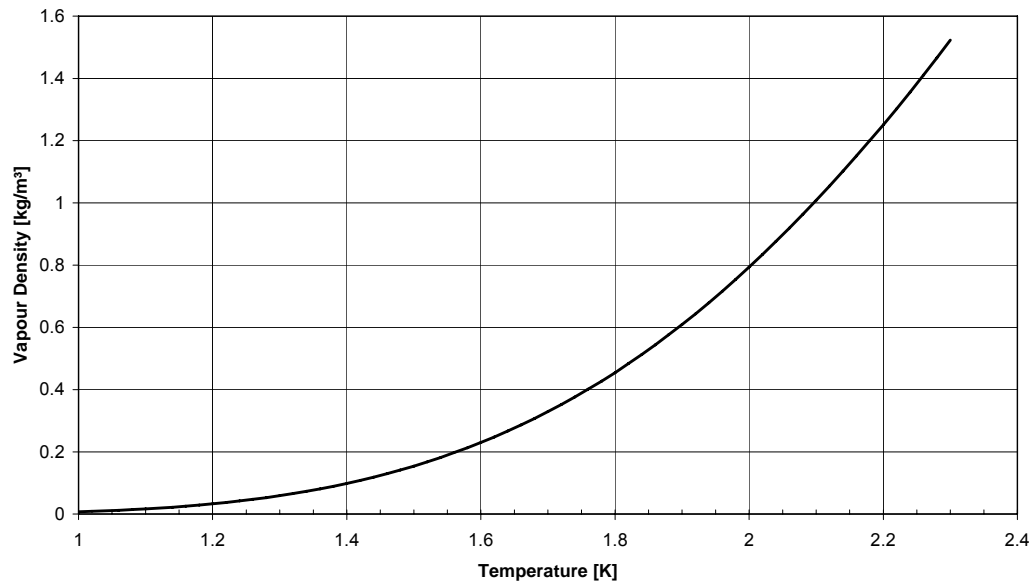

Figure 5.5-2: Vapour Density of Helium (Ref. /5/)

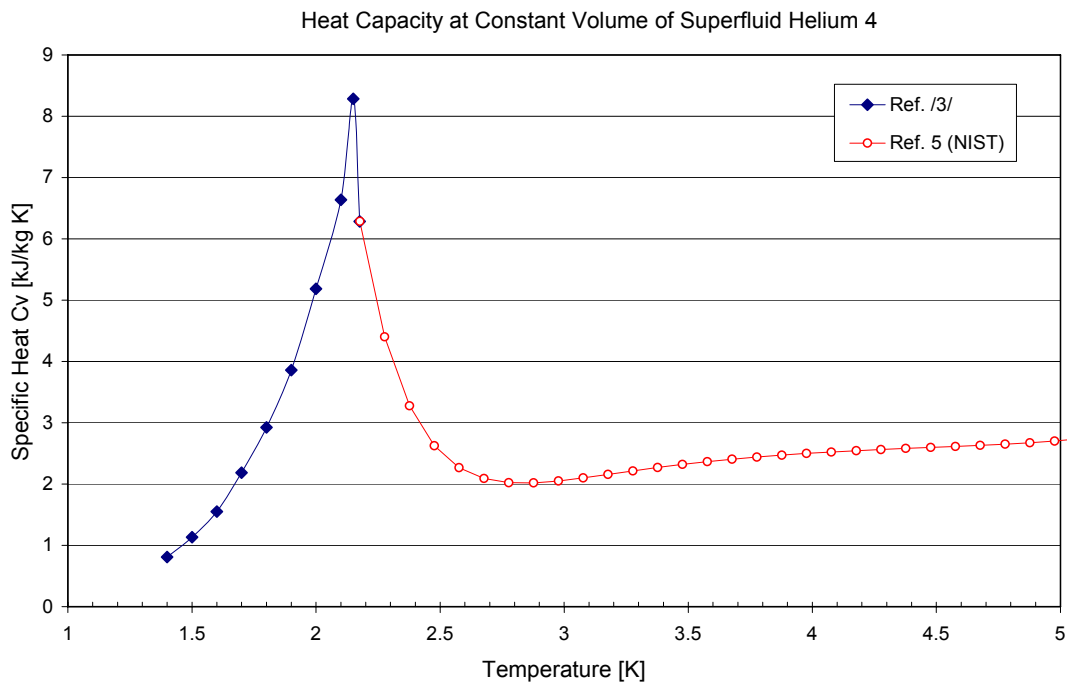

Figure 5.5-3: Volume Specific Heat Capacity of Liquid He on Saturation Line

5.6 References for Material Properties

- /1/ Evaluation of LINDE/ESTEC-MLI Measurements and Transformation to the ISO Cryostat MLI Design, Doc.No.: ISO.TN-B1430.007, dated 12.07.88
- /2/ VDI Kryoatlas BW 2407
- /3/ Thermophysical Properties of Helium from 2 to 1500K with pressures to 1000 Atm (National Bureau of Standards TN 631)
- /4/ W. Blanke: Thermophysikalische Stoffdaten, Springer 1989
- /5/ NIST Standard Reference Database 12: NIST Thermophysical Properties of Pure Fluids, Version 3.0.
- /6/ ASPI fax AS-FAX SE/SP/IS 2244/89, dated 30.01.89
- /7/ Hartwig & Knaak, Cryogenics, Nov. 84, p.645
- /8/ Touloukian: Thermophysical Properties of Matter, 1972
- /9/ MLI Test Report – Linde, Doc.No.: ISO-TR-C130.001, dated 19.02.88
- /10/ METOP Mechanical and Thermal Design Requirement Specification, Doc.No.; MO.RS.MMT.SY.0004, Issue 3, June 2000
- /11/ Comparative Performance Measurements on MLI Test Samples with different Types of Foils and Studs, Test Report: YCV/BA/136, dated 07.03.88
- /12/ Doenecke: Survey and Evaluation of Multilayer Insulation Heat Transfer Measurement, ICES July 1993
- /13/ Reed and Golda: Cryogenic composite supports, Cryogenics 1997, p.233
- /14/ ISO Thermal Mathematical Model, Version 7.12
- /15/ NIST Data Base, http://cryogenics.nist.gov/NewFiles/material_properties.html
- /16/ Data delivered by Th. Passvogel, ESA-FAX-PT-01750, dated 23.02.1996
- /17/ Guy K. White: Experimental Techniques in Low Temperature Physics, Handbook on Materials for Superconductivity Machinery, 3rd Edition
- /18/ Thermomechanical Analysis, HP-2-ECAS-AN-0004, Issue 2, dated 28.11.03

6 Thermal Analysis Results

6.1 Operation On Ground

6.1.1 On-Ground Lifetime

A heat flow chart based on ground case analysis is shown in Figure 6.1-1. Included are the CVV internal main heat paths, the temperatures of the different components and the GHe mass flow rate. The PPS in this configuration is bypassed, the different ventline path is also considered in the TMM.

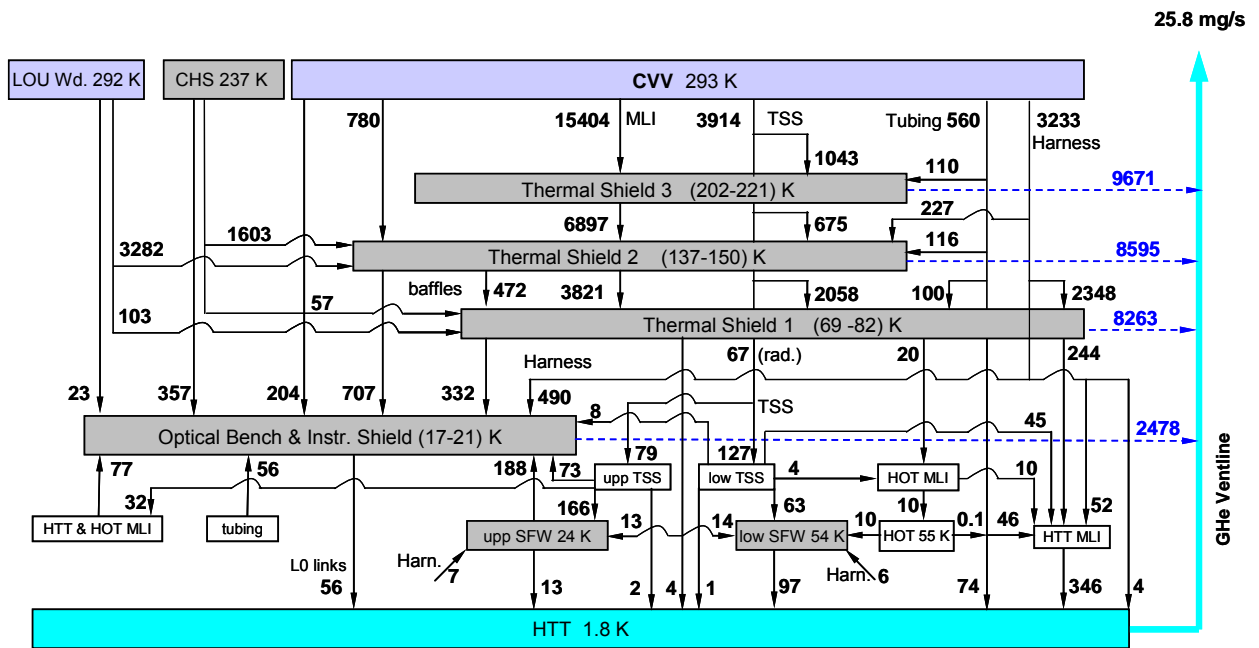

Only main paths are shown. All values are in [mW]

Figure 6.1-1: CVV Heat Flow Chart for On-Ground Environment

The sensitivity analysis performed for ground case conditions is summarised in Table 6.1-1 and Table 6.1-2. Generally, the uncertainties for the different items are assumed to be between $\pm 20\%$ for mechanical support structures and $\pm 50\%$ for MLI conductance.

General remarks for sensitivity tables:

- $\pm 50\%$ means 1.5 x nominal value for + 50%, 0.5 x nominal values for -50%
- Highlighting in color in the tables indicates the extreme values in the respective column
- Overall uncertainties are calculated as root square sum
- In the graphical representation tables, the number of bars per field indicates the relative magnitude (wrt the maximum value in the same column) of the respective sensitivity

	label	Variation	HOT [K]	OBA [K]	TS1 [K]	TS2 [K]	TS3 [K]	mdot [mg/s]	HTT_Heat [mW]
Reference value			54.66	19.71	77.89	144.94	215.45	25.79	597.8
Overall uncertainty	pos		8.46	4.61	9.00	10.59	14.72	1.99	45.9
	neg		-5.91	-2.00	-6.04	-11.72	-21.85	-2.90	-67.6
HTT MLI conductance	k_1	-50%	7.51	4.45	8.54	6.24	3.57	-1.06	-24.7
		50%	-3.59	-1.87	-4.16	-3.19	-1.87	0.55	12.7
TS1 MLI conductance	k_2a	-50%	-1.49	0.84	-2.19	4.96	2.87	-0.77	-17.9
		50%	0.75	-0.41	1.07	-2.61	-1.54	0.42	9.5
TS2 MLI conductance	k_2b	-50%	-1.91	-0.32	-2.13	-6.59	5.95	-1.46	-34.0
		50%	1.17	0.21	1.30	3.93	-3.72	0.94	21.6
TS3 MLI conductance	k_2c	-50%	-2.85	-0.33	-2.98	-8.62	-21.31	-2.09	-48.5
		50%	1.85	0.24	1.94	5.48	12.45	1.44	33.2
HTT bones	k_3	-20%	2.76	0.26	0.54	0.41	0.23	-0.07	-1.7
		20%	-2.37	-0.21	-0.46	-0.35	-0.20	0.06	1.3
inner tank suspension	k_4	-20%	-1.30	0.12	0.54	0.42	0.25	-0.07	-1.8
		20%	1.13	-0.10	-0.51	-0.41	-0.24	0.07	1.5
TS 1/2 tank susp.	k_5	-20%	-0.60	0.24	-0.29	1.18	0.81	-0.22	-5.2
		20%	0.51	-0.20	0.24	-1.06	-0.73	0.20	4.6
TS 2/3 tank susp.	k_6	-20%	-0.40	0.02	-0.34	-0.67	0.72	-0.24	-5.8
		20%	0.35	-0.01	0.29	0.58	-0.66	0.23	5.1
outer tank suspension	k_7	-20%	-0.31	-0.02	-0.30	-0.81	-1.50	-0.21	-5.1
		20%	0.28	0.02	0.27	0.73	1.36	0.21	4.6
CVV int. harness conduct. (=k_9)	k_8	-15%	0.28	0.02	0.27	0.73	1.36	0.21	4.6
		15%	0.48	0.40	0.62	-0.36	-0.62	0.57	13.1
He vapourisation heat	k_11	-1%	-0.26	-0.14	-0.32	-0.26	-0.16	0.05	-4.9
		1%	0.25	0.14	0.31	0.24	0.14	-0.04	4.8
Stycast comb at TS1	k_17	-90%	-0.32	0.53	-0.42	-0.14	0.02	-0.10	-2.5
		90%	0.01	-0.03	0.02	0.00	-0.01	0.01	0.1
Stycast comb at OBP	k_18	-90%	-0.01	-0.02	-0.01	-0.01	-0.01	0.01	-0.1
		90%	-0.01	0.00	-0.01	-0.01	-0.01	0.01	0.0

Table 6.1-1: Sensitivities for Operation on Ground

	label	HOT	OBA	TS1	TS2	TS3	mdot	HTT_Heat
Reference		54.66	19.71	77.9	144.9	215.5	25.8	597.8
Overall uncertainty	pos	8.46	4.61	9.00	10.59	14.72	1.99	45.9
	neg	-5.91	-2.00	-6.04	-11.72	-21.85	-2.90	-67.6
HTT MLI conductance	-50%							
	50%							
TS1 MLI conductance	-50%							
	50%							
TS2 MLI conductance	-50%							
	50%							
TS3 MLI conductance	-50%							
	50%							
HTT bones	-20%							
	20%							
inner tank suspension	-20%							
	20%							
TS 1/2 tank susp.	-20%							
	20%							
TS 2/3 tank susp.	-20%							
	20%							
outer tank suspension	-20%							
	20%							
CVV int. harness conductance	-15%							
	15%							
He vapourisation heat	-1%							
	1%							
Stycast comb at TS1	-90%							
	90%							
Stycast comb at OBP	-90%							
	90%							

Note: The number of bars per field indicates the relative magnitude of the respective sensitivity

Table 6.1-2: Graphical representation of sensitivities for Operation on Ground

6.1.2 On-Ground Autonomy (closed HTT)

The parameter determining the length for the on-ground autonomy is the temperature of the He II in the main tank, which shall be below 2.1 K after 6 days.

The on-ground autonomy analysis is based on the following steady state start conditions (time $t=0$):

- System Pre-cooling with a He mass flow of 1000 mg/s
- HOT He mass flow: 25 mg/s (HOT heating)
- Start temperature of HTT: 1.8 K
- Temperature of HOT: 4.2 K (fixed boundary until HOT is empty)
- CVV temperature: 293 K (fixed boundary)

The results shown in Figure 6.1-2 reveal that the HTT is below 2.1 K after 6 days. In addition to the nominal analysis, a sensitivity case has been run where the MLI conductive coupling of the TS2 and TS3 is increased by 50%. When these two major sensitivities are applied at the same time, the HTT temperature reaches 2.1 K after 6.4 days, which is still well within the requirement.

The bend in the HTT temperature curves indicates that the HOT He reservoir of 8.75 kg is exhausted after four days.

Note: A cross-check calculation without heating of the HOT showed that the floating mass flow from the HOT is below 25mg/s during the first 6 day. This means, that the HOT tank needs to be heated in order to achieve a constant HOT mass flow of 25 mg/s.

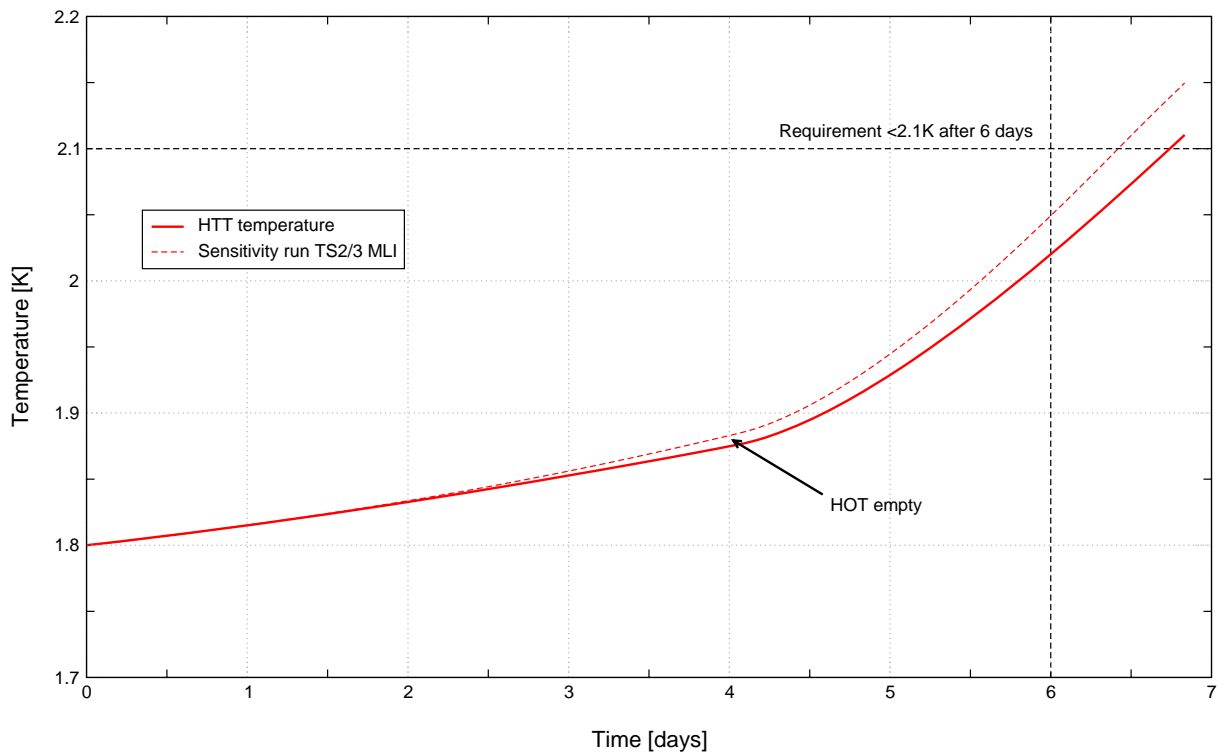

Figure 6.1-2: HTT Temperature Evolution during Ground Autonomy for nominal and sensitivity case

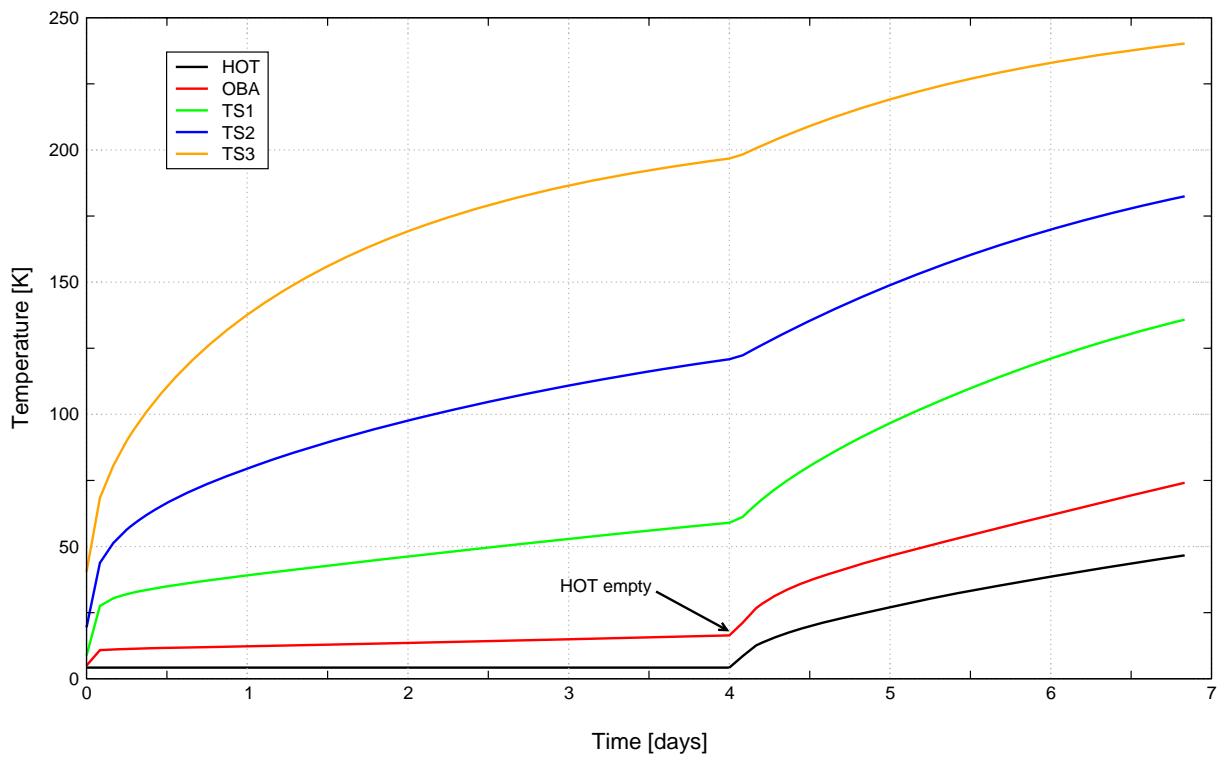

Figure 6.1-3: Thermal Shields Temperature Evolution during Ground Autonomy for 25 mg/s HOT Mass Flow Rate, nominal case

6.2 Pre-Launch and Early Orbit Phase

For the pre-launch and early orbit phase three scenarios have been investigated in accordance with the POC operations as discussed with Arianespace [RD 41]:

1. Nominal scenario with no launch delay (acc to Annex 1 of [AD 06]):
 - Helium II top up completed 4 days before launch with a level of 98% and a temperature of 1.8 K
 - Last HOT refill with Thermal Shields subcooling completed two days before launch
 - HOT depletion and heating to 55 K 3 hours before launch (using 10 W nominal depletion heater)
2. Scenario with 25 hours launch delay:
 - Same as 1., but additionally:
 - Launch abort after HOT heating
 - 25 hours hold time with depleted HOT
3. Scenario with degraded internal MLI performance (sensitivity):
 - Same as 2., but:
 - 50% higher MLI conductance ($k1 = 1.5$ and $k2 = 1.5$) and simultaneously 15% increased internal harness conductance ($k8 = 1.15$)

Critical areas that are exposed to an intensive solar as well as aero-thermal flux are investigated in RD 17. The cool-down of the HSS after fairing jettison has been assessed for an extreme S/C attitude, see also RD 17.

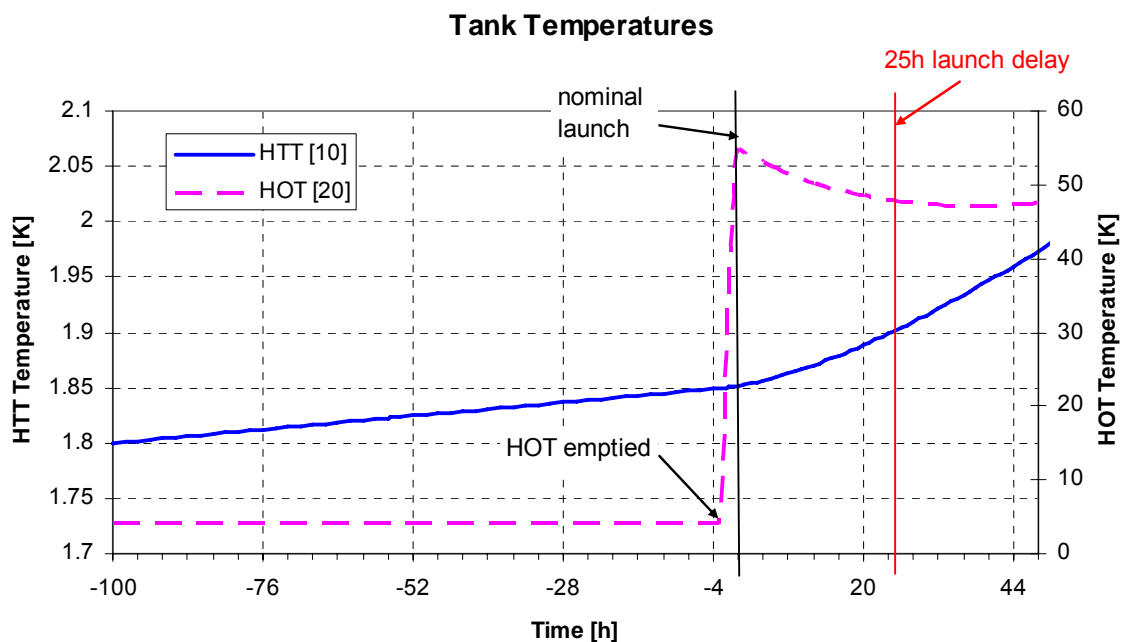

Figure 6.2-1: HTT and HOT Temperature Evolution during Pre-Launch Phase

Thermal Shield Temperatures

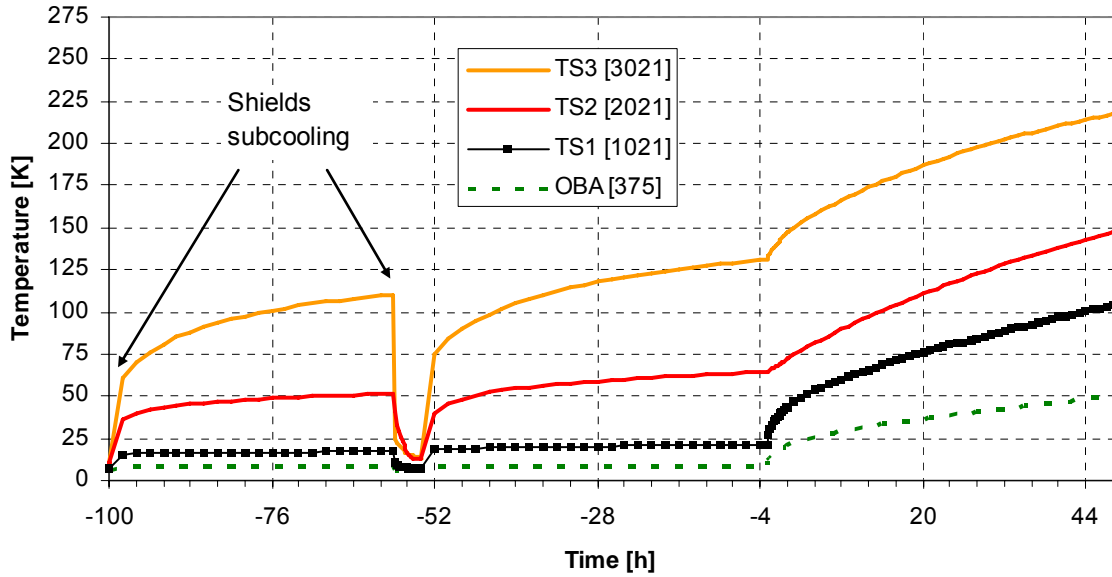

Figure 6.2-2: Thermal Shield Temperature Evolution during Pre-Launch Phase

HOT He Massflow

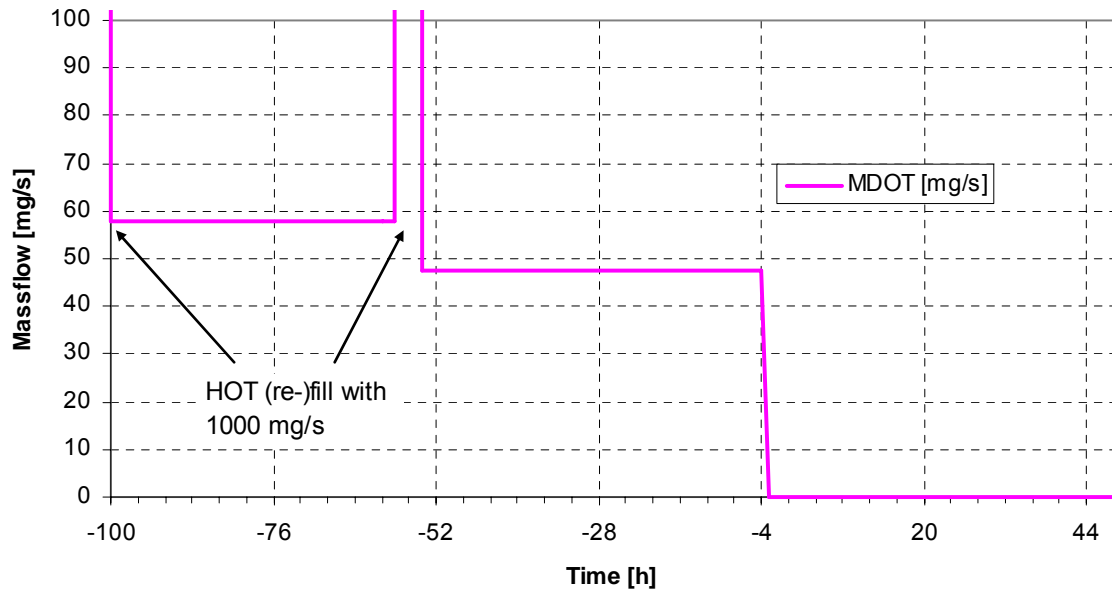

Figure 6.2-3: HOT He Massflow during Pre-Launch Phase

For the launch phase of 200 sec (launch until fairing jettison), a heat flux of 1000 W/m² radiated by the fairing is assumed [AD 05]. The temperature evolution of some exposed external parts is shown in Figure 6.2-4.

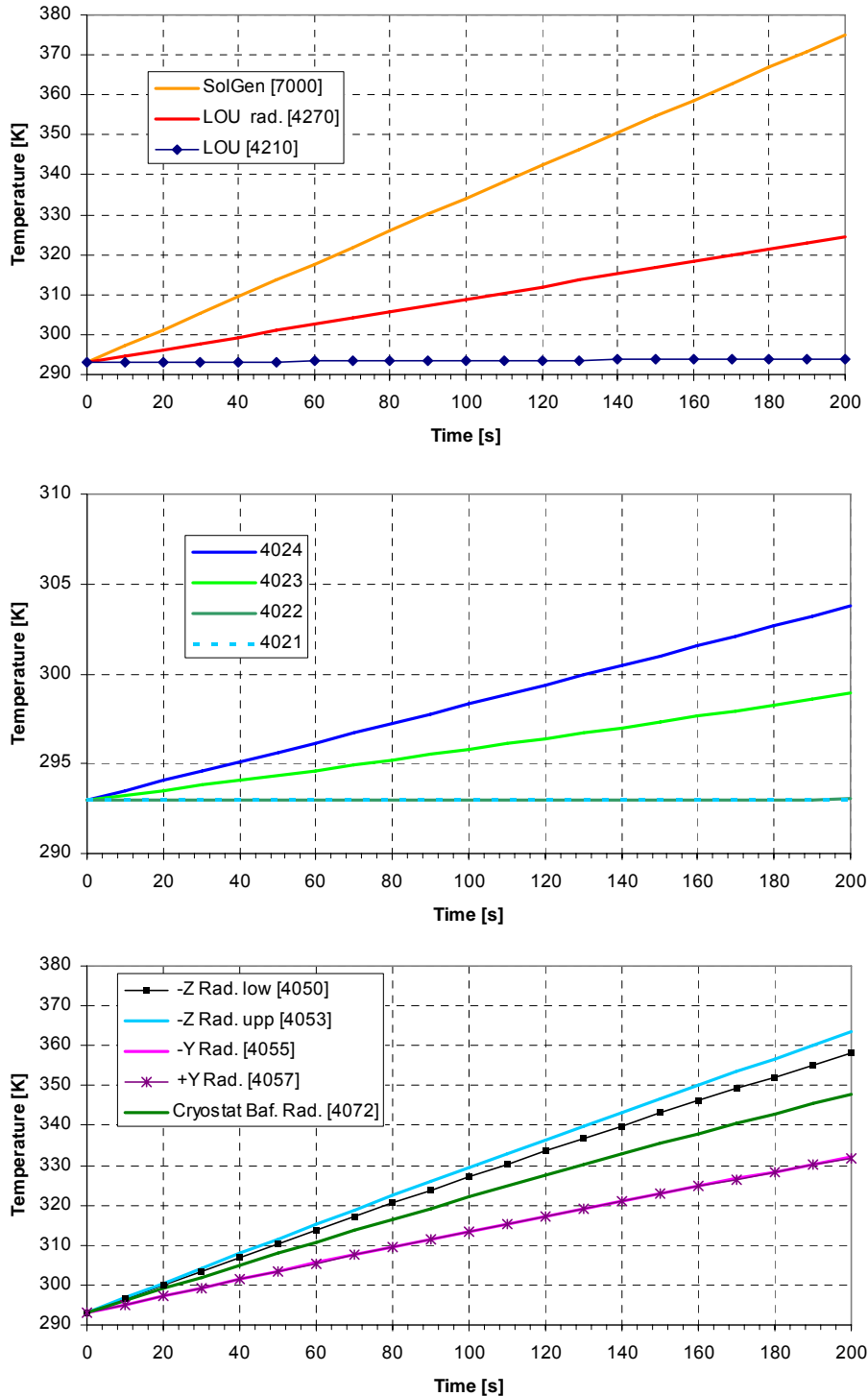
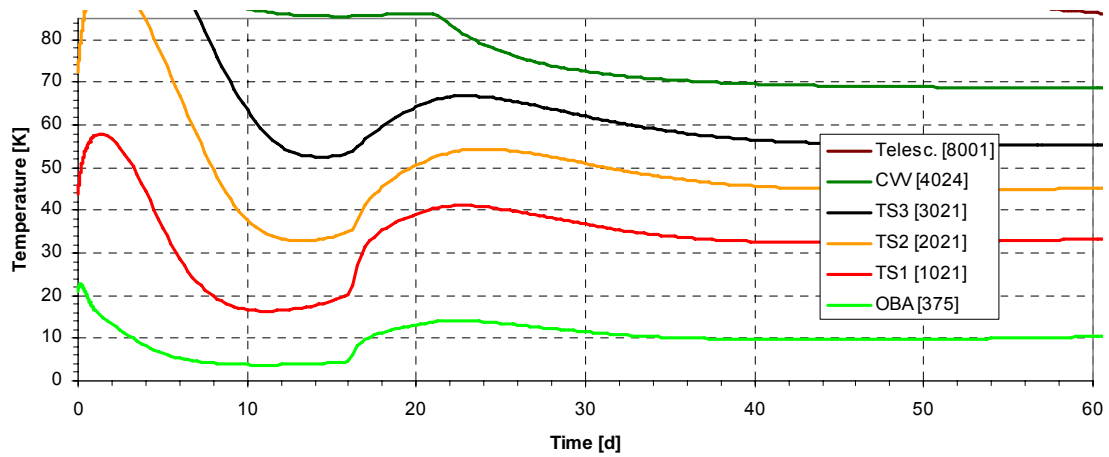
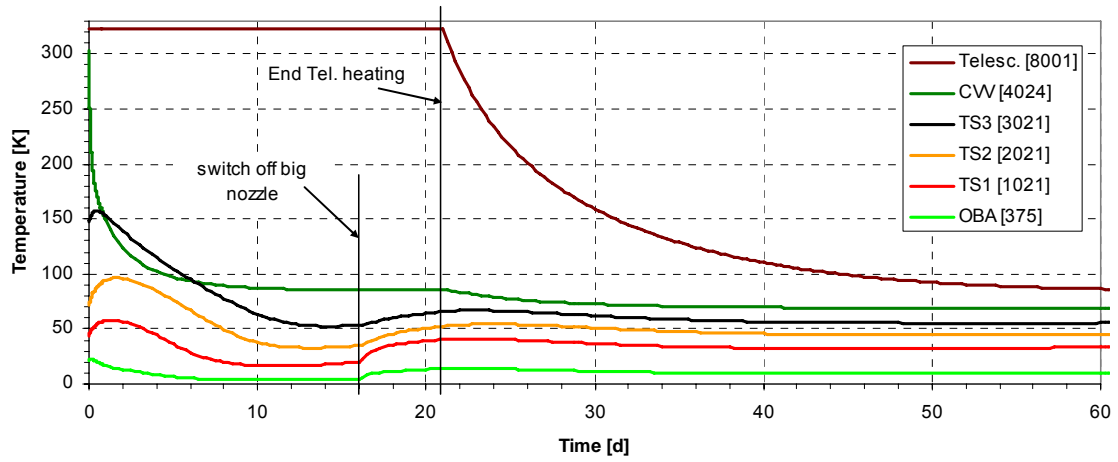

Figure 6.2-4: H-EPLM Temperatures during Launch Phase

Thermal Shields, CVW & Telescope Temperatures



LOU & CW

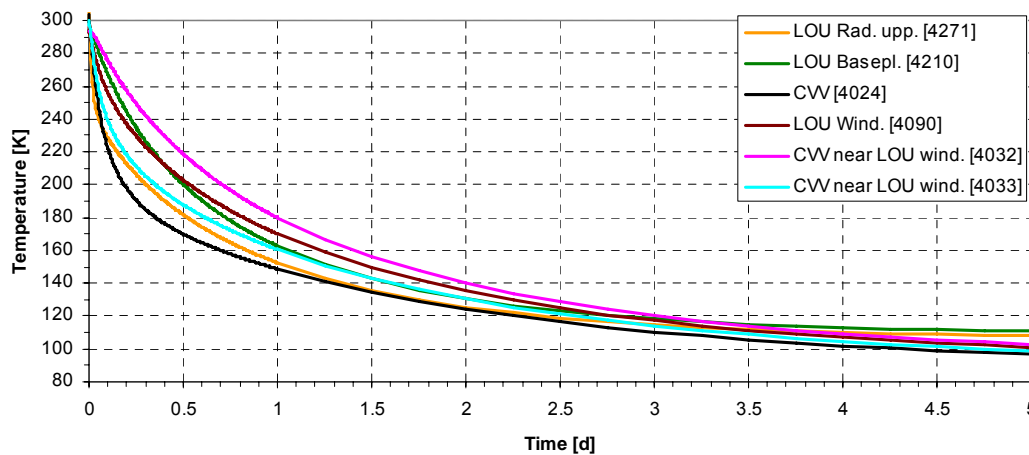

Figure 6.2-5: H-EPLM Temperatures during In-Orbit Cool-Down

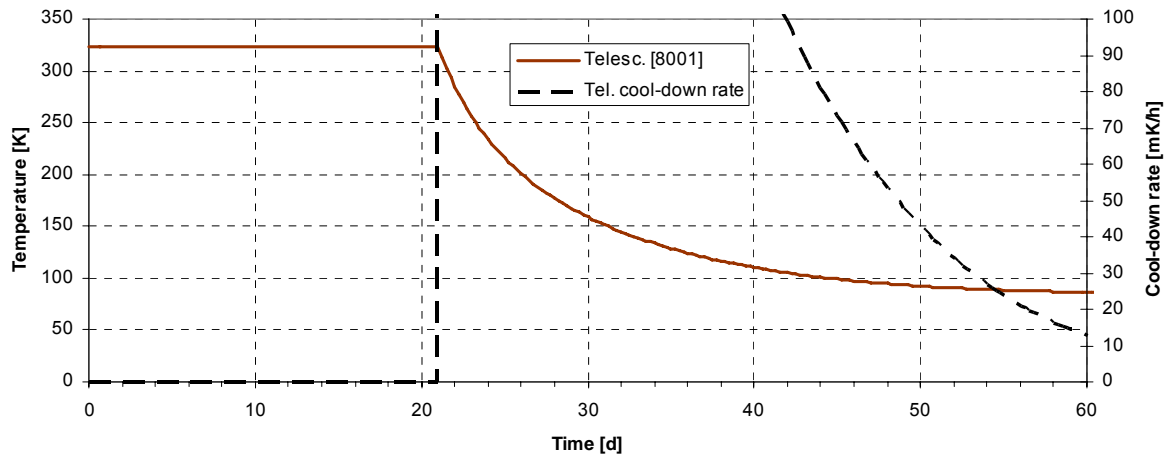

Figure 6.2-6: Telescope Cool-Down Rate after Decontamination (Cover still closed)

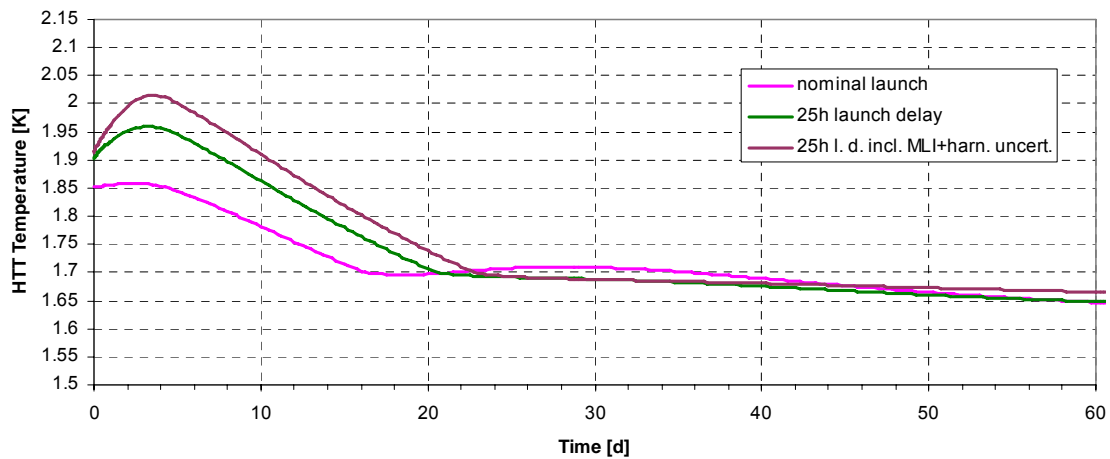

Figure 6.2-7: HTT Temperature during In-Orbit Cool-Down

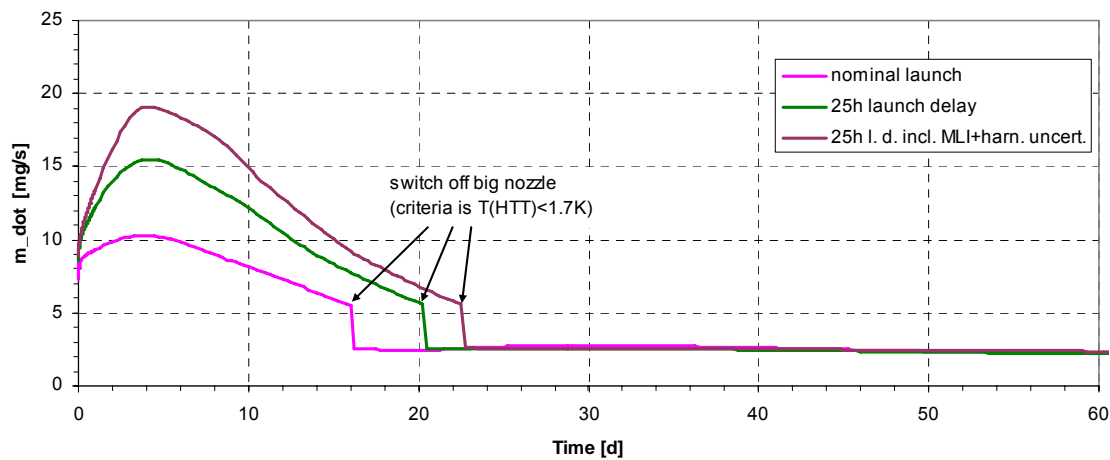

Figure 6.2-8: Helium Mass flow during In-Orbit Cool-Down

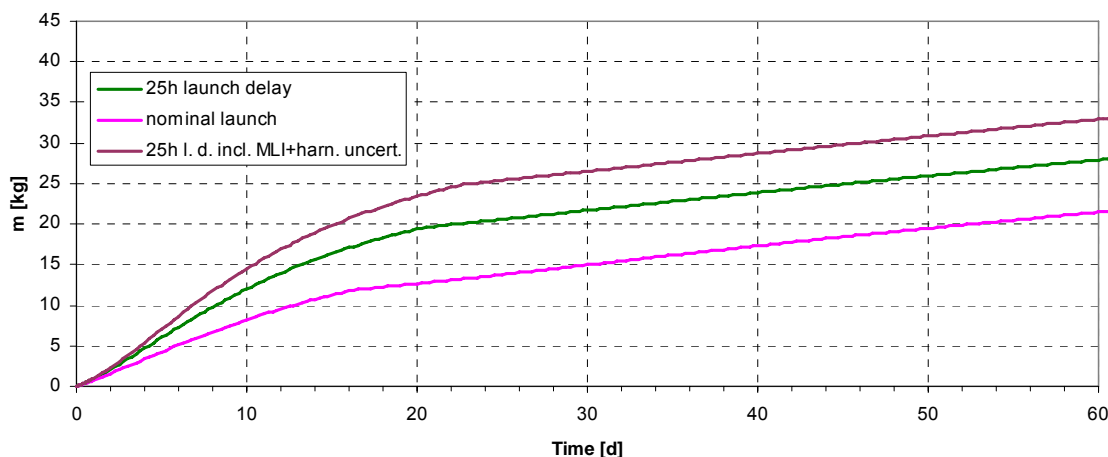

Figure 6.2-9: Helium Mass Loss during In-Orbit Cool-Down

During the telescope decontamination (heating) phase, a dissipation of the telescope heater harness of 13.5 W is considered [RD 42]. The impact of this additional heat to the He mass consumption is +0.22 kg, as a comparative calculation without harness dissipation showed (with ~59 ¾ days cool down). It is recommended to take special care for the harness temperature itself on hardware side (in the frame of TB/TV testing), which in the TMM reaches values up to 435 K (partly routed under MLI, strongly dependent on estimated local view factors to CVV/deep space)!

Acc. to [AD 06], the end of the transient cool down phase is reached after

- Telescope decontamination and cool down until a rate of < 0.03 K/hour
- Cryo-cover opening
- Nozzle switch
- HTT has reached 1.65 K

Table 6.2-1 summarises the helium losses and HTT temperatures for the above-described scenarios.

	Nominal launch	Launch delay	Uncertainty launch delay (MLI+harness)	Reference
Duration of transient cool down	58 days (1)	58.5 days (2)	> 80 days (3)	
He loss during cool down	21.1 kg (1)	27.6 kg (2)	> 37 kg (3)	Figure 6.2-9
T (HTT) at launch	1.852 K	1.901 K	1.914 K	Figure 6.2-1
T (HTT, max)	1.859 K	1.959 K	2.015 K	Figure 6.2-7

(1) taken for lifetime analysis, see section 6.5

(2) taken for lifetime uncertainty

(3) out of calculated time frame

Table 6.2-1: Helium loss and HTT temperatures during in-orbit cool down

For the uncertainty launch delay, the margin w.r.t. available Helium enthalpy until the maximum allowable HTT temperature of 2.1 K would be reached is 125% (same approach as in [RD 40]), which is considered to be sufficient.

6.3 Spacecraft Operation in L2 Orbit

6.3.1 Steady State Analysis for Hot and Cold Case Conditions

Thermal analyses with implemented instrument models have been performed both for the hot and cold case thermal environment at L2 (for definition see Table 3.2-1).

The main results are summarized in Table 6.3-1. The corresponding heat flow charts showing the CVV external main paths are shown in Figure 6.3-3 for the hot case environment and in Figure 6.3-4 for the cold case environment. The calculated temperatures of the relevant components are included. The internal heat flow chart for the hot case environment is shown in Figure 6.3-5. A detailed listing of all node temperatures is given in the annex.

	T (CVV)	T (TS3)	T (TS2)	T (TS1)	T (OBA)	T (HTT)	He Mass Flow
Hot case	67.4 K	54.8 K	45.4 K	34.2 K	13.0 K	1.65 K / boundary	2.331 mg/s
Cold case	64.2 K	52.4 K	43.6 K	33.1 K	12.8 K	1.639 K	2.177 mg/s
Safe Mode *	60.3 K	50.1 K	42.2 K	32.2 K	11.4 K	1.595 K	1.764 mg/s
Average (IID-B) **	65.9 K	53.7 K	44.6 K	33.7 K	12.9 K	1.65 K / boundary	2.261 mg/s

*) All dissipation set to zero + SVM in safe mode; thermal environment equal to cold case

**) Used for lifetime calculation

Table 6.3-1: Analysis Results for Hot and Cold Case Environment

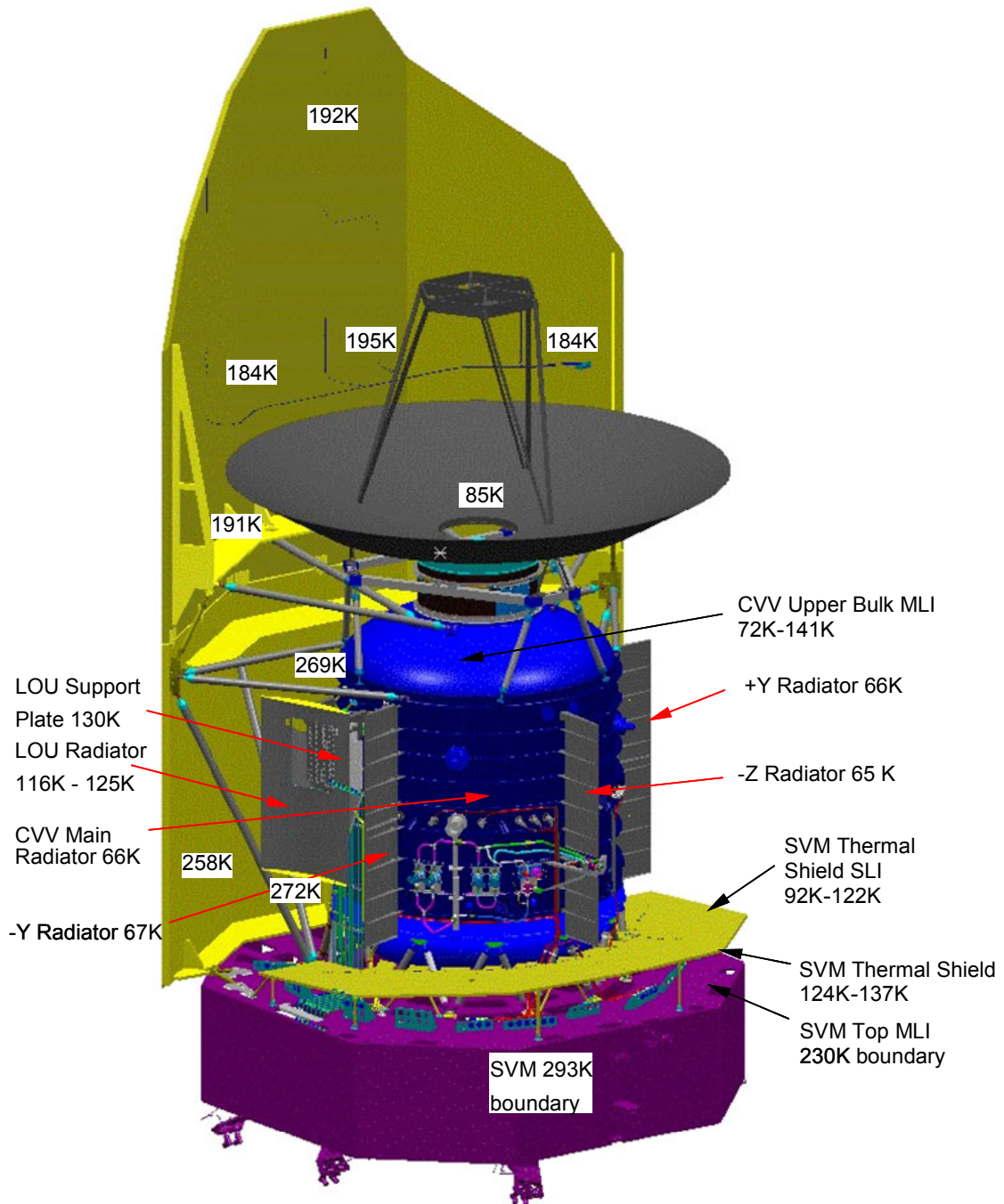
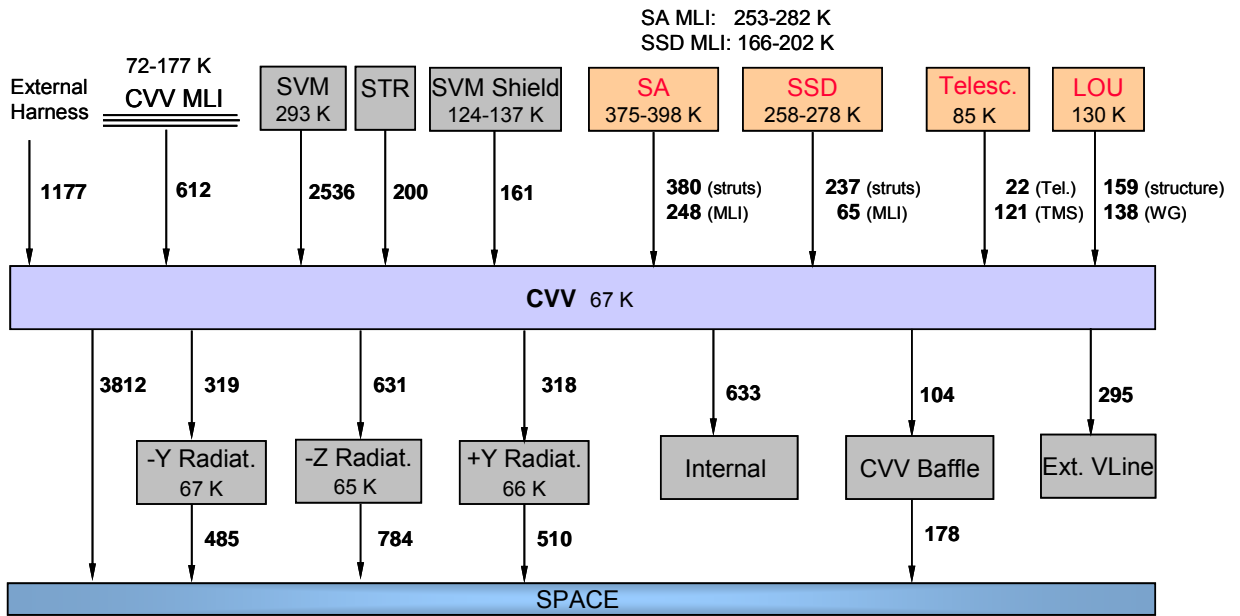
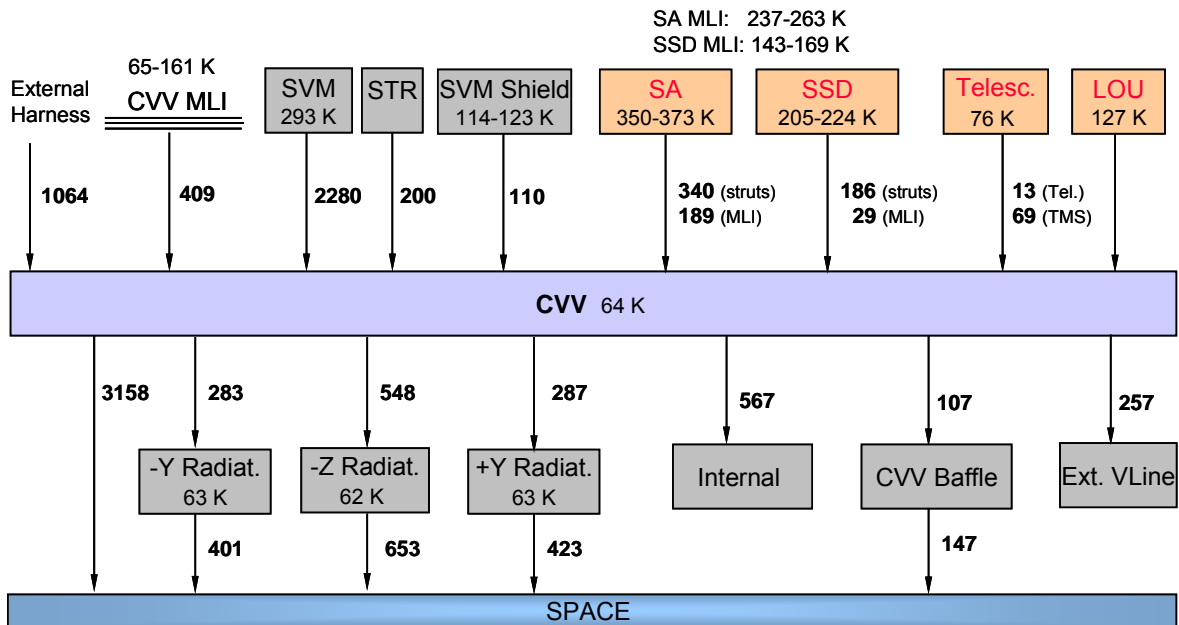

Figure 6.3-1: H-EPLM Temperature Distribution for Hot Case Environment at L2



All values are in [mW]

Figure 6.3-3: CVV Heat Flow Chart for Hot Case Environment at L2



All values are in [mW]

Figure 6.3-4: CVV Heat Flow Chart for Cold Case Environment at L2

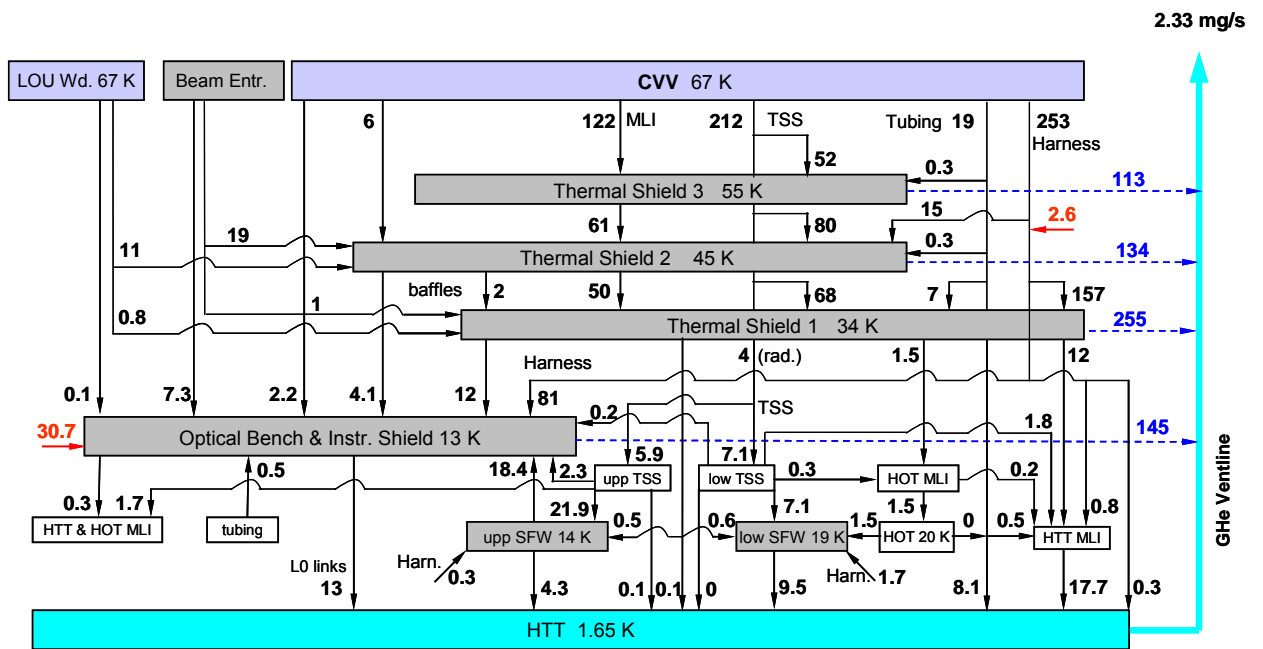

Only main paths are shown. All values are in [mW]

Figure 6.3-5: HPLM internal Heat Flow Chart for Average Instrument Dissipation and Hot Case Environment at L2

6.3.2 Sensitivity Analysis for Lifetime and EPLM Temperatures

A comprehensive sensitivity analysis has been performed for In-Orbit operations. The results are listed in the following tables. Compared to the last issue, an additional sensitivity concerning the emissivity of the SVM-CVV struts has been implemented [RD 58].

General remarks for sensitivity tables:

- ± 50% means 1.5 x nominal value for + 50%, 0.5 x nominal values for -50%
- Highlighting in color in the tables indicates the extreme values in the respective column
- Overall uncertainties are calculated as root square sum
- In the graphical representation tables, the number of bars per field indicates the relative magnitude (wrt the maximum value in the same column) of the respective sensitivity
- “HTT temp (dp) uncertainty” indicates the uncertainty of the respective temperature for an error in the pressure drop model by ±1.5 mbar
- The “Updated HSS MLI definition” replaces the negative sensitivities of the HSS MLI conductances k_22/k_23 and represents the more realistic MLI performance formulation based on calorimeter test results. The degradation factors that have to be considered due to the actual MLI setup on the H/W have not yet been verified by test. Therefore the HSS MLI definition in the reference TMM is still based on the effective emissivity formulation which is considered to be very conservative.

	label	Variation	HTT [K]	mdot [mg/s]	HOT [K]	OBA [K]	TS1 [K]	TS2 [K]	TS3 [K]
Reference value			1.659	2.342	19.685	12.999	34.216	45.434	54.843
Overall uncertainty	pos		0.040	0.162	1.478	0.525	0.871	1.303	1.766
	neg		-0.044	-0.235	-1.655	-0.564	-1.473	-2.418	-3.219
HTT temp (dp) uncertainty		1.5mbar	0.0363						
		1.5mbar	-0.0409						
HTT MLI conductance	k_1	-50%	-0.0001	-0.0012	-0.1155	0.017	0.023	0.018	0.012
		50%	0.0000	-0.0003	0.0482	0.000	0.001	0.002	0.002
TS1 MLI conductance	k_2a	-50%	-0.0011	-0.0118	-0.0781	0.023	-0.122	0.186	0.112
		50%	0.0004	0.0042	0.0386	0.000	0.059	-0.063	-0.037
TS2 MLI conductance	k_2b	-50%	-0.0013	-0.0145	-0.0710	0.000	-0.093	-0.354	0.193
		50%	0.0009	0.0098	0.0315	0.001	0.040	0.173	-0.106
TS3 MLI conductance	k_2c	-50%	-0.0025	-0.0239	-0.1302	-0.002	-0.166	-0.549	-1.136
		50%	0.0017	0.0162	0.0717	0.002	0.091	0.309	0.645
HTT bones	k_3	-20%	-0.0010	-0.0115	1.1889	0.173	0.185	0.131	0.084
		20%	0.0013	0.0150	-1.0405	-0.163	-0.188	-0.140	-0.094
inner tank suspension	k_4	-20%	-0.0016	-0.0178	-0.6989	0.000	0.232	0.184	0.121
		20%	0.0015	0.0166	0.6086	0.002	-0.214	-0.170	-0.112
TS 1/2 tank susp.	k_5	-20%	-0.0018	-0.0209	-0.2081	0.041	-0.240	0.316	0.212
		20%	0.0021	0.0233	0.1672	-0.043	0.189	-0.305	-0.207

	label	Variation	HTT [K]	mdot [mg/s]	HOT [K]	OBA [K]	TS1 [K]	TS2 [K]	TS3 [K]
TS 2/3 tank susp.	k_6	-20%	-0.0022	-0.0241	-0.1332	0.000	-0.168	-0.519	0.242
		20%	0.0021	0.0224	0.1089	0.002	0.137	0.424	-0.207
outer tank suspension	k_7	-20%	-0.0022	-0.0208	-0.1125	-0.001	-0.143	-0.471	-0.837
		20%	0.0018	0.0169	0.1061	0.014	0.136	0.402	0.696
CVV int. harness conductance (=k_9)	k_8	-15%	-0.0107	-0.1145	-0.4189	-0.488	-0.523	-0.069	0.111
		15%	0.0107	0.1156	0.3682	0.452	0.453	0.042	-0.122
Int. harness dissipation	k_10	-20%	-0.0010	-0.0108	-0.0144	-0.115	-0.021	0.010	0.015
		20%	0.0015	0.0157	-0.0011	0.108	-0.001	-0.033	-0.033
He vapourisation heat	k_11	-1%	0.0009	0.0099	-0.0583	-0.056	-0.084	-0.070	-0.049
		1%	-0.0004	-0.0049	0.0415	0.050	0.060	0.045	0.030
Stycast comb at TS1	k_17	-90%	-0.0003	-0.0036	-0.1334	0.138	-0.196	-0.097	-0.047
		90%	0.0000	0.0001	0.0139	0.000	0.020	0.013	0.008
Stycast comb at OBP	k_18	-10%	0.0002	0.0022	-0.0060	-0.016	-0.009	-0.010	-0.008
		90%	0.0000	0.0004	-0.0025	-0.001	-0.004	-0.003	-0.002
CVV MLI conductance	k_21	-50%	-0.0038	-0.0310	-0.1748	-0.023	-0.240	-0.380	-0.536
		50%	0.0037	0.0302	0.1571	0.022	0.215	0.342	0.487
Sunshield MLI conduct.	k_22	50%	0.0074	0.0620	0.2734	0.040	0.372	0.634	0.875
Sunshade MLI conduct.	k_23	50%	0.0021	0.0193	0.0512	0.028	0.068	0.158	0.166
Updated HSS MLI def.	-	n/a	-0.0087	-0.1847	-0.8416	-0.177	-1.155	-2.012	-2.615
SVM shield MLI emiss.	k_24	0.03	0.0021	0.0174	0.0715	0.025	0.097	0.147	0.217
CVV strut conductance	k_25	-20%	-0.0057	-0.0465	-0.2534	-0.032	-0.348	-0.551	-0.783
		20%	0.0059	0.0488	0.2200	0.023	0.300	0.491	0.714
HSS strut conductance	k_26	-20%	-0.0019	-0.0159	-0.0693	-0.002	-0.095	-0.163	-0.238
		20%	0.0019	0.0158	0.0849	0.018	0.116	0.183	0.255
CVV ext. harness conductance (=k_28)	k_27	-15%	-0.0025	-0.0199	-0.1199	-0.017	-0.165	-0.246	-0.333
		15%	0.0026	0.0215	0.1148	0.021	0.158	0.233	0.317
Ext. harness dissipation	k_29	-15%	-0.0001	-0.0005	-0.0017	0.000	-0.002	-0.004	-0.006
		15%	0.0001	0.0005	0.0017	0.000	0.002	0.004	0.006
Sunshade emissivity	k_32	-0.03	0.0005	0.0046	-0.0004	0.001	-0.001	0.009	0.014
		0.03	-0.0003	-0.0025	-0.0027	0.000	-0.003	-0.014	-0.017
Solar generator emissivity	k_33	-0.03	0.0011	0.0094	0.0253	0.001	0.034	0.065	0.096
		0.03	-0.0009	-0.0072	-0.0252	0.000	-0.034	-0.064	-0.093
Sunshade OSR absorptivity	k_34	-0.03	-0.0008	-0.0064	-0.0405	-0.018	-0.055	-0.102	-0.107
		0.03	0.0009	0.0083	0.0393	0.023	0.053	0.097	0.102
Solar generator absorptivity	k_35	-0.03	-0.0009	-0.0075	-0.0264	0.000	-0.036	-0.067	-0.097
		0.03	0.0009	0.0081	0.0265	0.001	0.036	0.066	0.095
LOU strut conductance	k_38	-20%	-0.0004	-0.0034	-0.0120	0.000	-0.016	-0.029	-0.044
		20%	0.0004	0.0036	0.0112	0.000	0.015	0.028	0.043
MLI IR specularity	k_30	-20%	0.0044	0.0369	0.1413	0.032	0.192	0.338	0.464
		20%	-0.0041	-0.0335	-0.1660	-0.040	-0.226	-0.376	-0.509
Emissivity of radiator surfaces	k_31	-0.03	0.0015	0.0123	0.0653	0.000	0.067	0.115	0.168
		0.03	-0.0016	-0.0129	-0.0546	-0.001	-0.076	-0.134	-0.191
Telescope M1	k_36	-0.03	0.0006	0.0060	0.0064	0.001	0.008	0.024	0.037

	label	Variation	HTT [K]	mdot [mg/s]	HOT [K]	OBA [K]	TS1 [K]	TS2 [K]	TS3 [K]
emissivity		0.03	-0.0004	-0.0033	-0.0094	0.000	-0.013	-0.025	-0.037
Emissivity of radiating struts	-	-0.03	0.0000	0.0003	-0.0003	0.000	0.000	-0.001	0.001
		0.03	0.0001	0.0006	-0.0030	0.000	-0.004	-0.005	-0.002

Note: The "Updated HSS MLI definition" replaces the negative sensitivities of k_22/k_23 and represents the more realistic MLI performance approximation based on calorimeter tests (degradation factors not yet verified by test)

Table 6.3-2: In-Orbit Sensitivities for CVV internal elements

	label	variation	CVV [K]	SVM-TS [K]	Telescope [K]	LOU_BP [K]	HTT_Heat [mW]	Lifetime [days]
Reference value			67.419	131.010	84.961	130.217	53.547	1439.865
Overall uncertainty	pos		1.962	2.141	5.378	2.561	3.785	145.324
	neg		-3.837	-5.453	-16.296	-6.500	-5.491	-90.746
HTT temp (dp) uncertainty		1.5mbar 1.5mbar						
HTT MLI conductance	k_1	-50%	0.002	0.000	-0.002	0.000	-0.0204	0.709
		50%	0.000	0.000	-0.001	0.000	-0.0010	0.154
TS1 MLI conductance	k_2a	-50%	0.009	0.000	0.001	0.000	-0.2721	6.864
		50%	-0.003	0.000	-0.003	0.000	0.1058	-2.407
TS2 MLI conductance	k_2b	-50%	0.012	0.000	0.000	0.000	-0.3301	8.418
		50%	-0.007	0.000	0.000	0.000	0.2131	-5.665
TS3 MLI conductance	k_2c	-50%	0.028	0.000	0.003	0.000	-0.5545	13.994
		50%	-0.017	0.000	-0.002	0.000	0.3655	-9.325
HTT bones	k_3	-20%	0.010	0.000	0.003	0.000	-0.2851	6.671
		20%	-0.011	0.000	-0.001	0.000	0.3340	-8.606
inner tank suspension	k_4	-20%	0.014	0.000	0.002	0.000	-0.4120	10.356
		20%	-0.013	0.000	-0.002	0.000	0.3833	-9.542
TS 1/2 tank susp.	k_5	-20%	0.017	0.000	0.004	0.000	-0.5054	12.181
		20%	-0.018	0.000	-0.002	0.000	0.5298	-13.349
TS 2/3 tank susp.	k_6	-20%	0.020	0.000	0.001	0.000	-0.5554	14.065
		20%	-0.017	0.000	-0.002	0.000	0.5089	-12.829
outer tank suspension	k_7	-20%	0.022	0.000	0.001	0.000	-0.4814	12.165
		20%	-0.017	0.000	-0.005	0.000	0.4065	-9.730
CVV int. harness conductance (=k_9)	k_8	-15%	0.097	0.000	0.017	0.001	-2.6951	69.646
		15%	-0.095	0.000	-0.014	-0.001	2.6935	-63.722
Int. harness dissipation	k_10	-20%	0.001	0.000	0.001	0.000	-0.2692	6.295
		20%	-0.003	0.000	0.001	0.000	0.3500	-8.996
He vapourisation heat	k_11	-1%	-0.006	0.000	0.000	0.000	-0.3230	-5.693
		1%	0.004	0.000	0.002	0.000	0.4028	2.854
Stycast comb at TS1	k_17	-90%	0.004	0.000	0.002	0.000	-0.1018	2.079

	label	variation	CVV [K]	SVM-TS [K]	Telescope [K]	LOU_BP [K]	HTT_Heat [mW]	Lifetime [days]
		90%	0.001	0.000	-0.002	0.000	0.0097	-0.035
Stycast comb at OBP	k_18	-10%	-0.001	0.000	0.001	0.000	0.0362	-1.289
		90%	0.000	0.000	0.000	0.000	0.0069	-0.259
CVV MLI conductance	k_21	-50%	-0.727	0.022	-0.094	0.008	-0.7478	18.171
		50%	0.665	-0.021	0.088	-0.008	0.7206	-17.267
Sunshield MLI conduct.	k_22	50%	1.200	2.092	3.313	2.390	1.4466	-34.935
Sunshade MLI conduct.	k_23	50%	0.205	0.093	2.010	0.178	0.4386	-11.099
Updated HSS MLI def.	-	n/a	-3.485	-5.417	-16.109	-6.439	-4.2610	115.972
SVM shield MLI emiss.	k_24	0.03	0.303	-0.268	0.047	-0.005	0.4125	-10.005
CVV strut conductance	k_25	-20%	-1.066	-0.179	-0.168	-0.011	-1.1124	27.425
		20%	0.996	0.159	0.162	0.011	1.1355	-27.655
HSS strut conductance	k_26	-20%	-0.343	-0.036	-0.118	-0.047	-0.3669	9.262
		20%	0.354	0.030	0.106	0.039	0.3817	-9.088
CVV ext. harness conductance (=k_28)	k_27	-15%	-0.434	-0.135	-0.102	-0.791	-0.4866	11.614
		15%	0.418	0.129	0.114	0.803	0.5159	-12.324
Ext. harness dissipation	k_29	-15%	-0.008	-0.001	-0.002	-0.012	-0.0110	0.283
		15%	0.008	0.001	0.002	0.012	0.0114	-0.296
Sunshade emissivity	k_32	-0.03	0.027	0.012	0.238	0.023	0.0913	-2.648
		0.03	-0.025	-0.011	-0.219	-0.021	-0.0535	1.456
Solar generator emissivity	k_33	-0.03	0.141	0.240	0.393	0.275	0.2056	-5.425
		0.03	-0.132	-0.224	-0.370	-0.258	-0.1621	4.180
Sunshade OSR absorptivity	k_34	-0.03	-0.120	-0.048	-1.005	-0.095	-0.1671	3.713
		0.03	0.117	0.048	0.974	0.095	0.2054	-4.813
Solar generator absorptivity	k_35	-0.03	-0.138	-0.233	-0.386	-0.268	-0.1686	4.345
		0.03	0.137	0.232	0.381	0.267	0.1808	-4.656
LOU strut conductance	k_38	-20%	-0.066	0.000	-0.011	0.077	-0.0761	1.961
		20%	0.065	0.000	0.011	-0.077	0.0795	-2.079
MLI IR specularity	k_30	-20%	0.640	0.203	0.460	0.074	0.8546	-21.037
		20%	-0.685	-0.376	-0.331	-0.070	-0.8070	19.678
Emissivity of radiator surfaces	k_31	-0.03	0.238	0.034	0.040	0.022	0.2856	-7.096
		0.03	-0.266	-0.123	0.001	-0.007	-0.2968	7.517
Telescope M1 emissivity	k_36	-0.03	0.061	-0.039	3.510	-0.015	0.1250	-3.466
		0.03	-0.055	-0.007	-2.133	-0.015	-0.0736	1.923
Emissivity of radiating struts	-	-0.03	0.003	-0.001	0.050	-0.011	0.0049	-0.154
		0.03	0.002	0.036	-0.007	-0.019	0.0104	-0.345

Table 6.3-3: In-Orbit Sensitivities for CVV external elements (CVV, SVM TS, Tel., LOU)

The case of 25 hours launch delay has also to be taken into account for the lifetime uncertainty. As stated in Table 6.2-1 the launch delay leads to a Helium consumption of 27.6 kg in 58.5 days compared to 21.1 kg in 58 days for nominal launch. This leads to an additional helium loss of 6.5 kg and a corresponding lifetime loss of 6.5 kg / (2.263 mg/s) -0.5 days = 33 days.

The overall uncertainty of the lifetime is evaluated using the sum root square of the uncertainty of 33 days due to 25 hours launch delay and the uncertainties shown in Table 6.3-3, leading to

-97 days for the negative sensitivities

+145 days for the positive sensitivities

	label	Vari- ation	SA MLI		SSD MLI		SA panel		SSD panel		SVM TS
			7100	7101	7160	7161	7000	7001	7060	7061	6204
Reference value			271.6	258.6	195.5	183.7	396.2	375.6	276.2	258.4	133.3
Overall uncertainty	pos neg		20.3 -82.5	18.9 -71.1	15.4 -53.0	14.2 -51.1	5.4 -5.1	5.0 -4.8	10.1 -11.2	9.5 -10.5	2.5 -6.2
CVV MLI conductance	k_21	-50% 50%	0.01 -0.01	0.01 -0.01	0.00 0.00	0.00 0.00	0.00 0.00	0.00 0.00	0.00 0.00	0.00 0.00	0.03 -0.02
Sunshield MLI conductance	k_22	50%	20.02	18.68	0.62	0.76	-0.79	-0.64	0.00	0.01	2.40
Sunshade MLI conductance	k_23	50%	0.06	0.06	13.75	12.67	0.00	0.00	-0.32	-0.28	0.11
Updated HSS MLI definition	-	n/a	-82.46	-71.06	-52.49	-50.64	1.83	1.41	0.68	0.64	-6.19
SVM shld MLI emiss.	k_24	0.03	0.01	-0.09	0.03	-0.04	0.00	0.00	0.00	0.00	-0.29
CVV strut conductance	k_25	-20% 20%	0.00 0.00	0.00 0.00	0.00 0.00	0.00 0.00	0.00 0.00	0.00 0.00	0.00 0.00	0.00 0.00	-0.22 0.20
HSS strut conductance	k_26	-20% 20%	-0.02 0.02	-0.02 0.02	-0.01 0.01	-0.01 0.01	0.00 0.00	0.00 0.00	0.00 0.00	0.00 0.00	-0.04 0.03
CVV ext. harness conductance (=k_28)	k_27	-15% 15%	0.01 -0.01	-0.01 0.01	0.00 0.00	0.00 0.00	0.03 -0.03	0.00 0.00	0.00 0.00	0.00 0.00	-0.10 0.09
Ext. harness dissipation	k_29	-15% 15%	0.00 0.00	0.00 0.00	0.00 0.00	0.00 0.00	0.00 0.00	0.00 0.00	0.00 0.00	0.00 0.00	0.00 0.00
Sunshade emissivity	k_32	-0.03 0.03	0.01 -0.01	0.01 -0.01	1.67 -1.57	1.49 -1.40	0.00 0.00	0.00 0.00	2.48 -2.33	2.23 -2.10	0.01 -0.01
Solar generator emissivity	k_33	-0.03 0.03	2.42 -2.31	2.26 -2.16	0.07 -0.07	0.09 -0.08	3.66 -3.49	3.48 -3.32	0.00 0.00	0.01 0.00	0.27 -0.26
Sunshade OSR absorptivity	k_34	-0.03 0.03	-0.03 0.03	-0.03 0.03	-7.37 6.62	-6.85 6.17	0.00 0.00	0.00 0.00	-10.98 9.81	-10.32 9.23	-0.06 0.06
Solar generator absorptivity	k_35	-0.03 0.03	-2.41 2.35	-2.24 2.19	-0.07 0.07	-0.09 0.09	-3.65 3.55	-3.45 3.36	0.00 0.00	-0.01 0.01	-0.27 0.27
LOU strut conductance	k_38	-20% 20%	0.00 0.00	0.00 0.00	0.00 0.00	0.00 0.00	0.00 0.00	0.00 0.00	0.00 0.00	0.00 0.00	0.00 0.00
MLI IR specularity	k_30	-20% 20%	0.29 -0.32	0.12 -0.29	0.24 -0.12	0.14 -0.20	0.01 0.00	0.00 0.00	0.00 0.00	0.00 0.00	0.26 -0.43
Emissivity of radiator	k_31	-0.03	0.02	-0.03	0.02	-0.03	0.00	0.00	0.00	0.00	0.03

	label	Variation	SA MLI		SSD MLI		SA panel		SSD panel		SVM TS
			7100	7101	7160	7161	7000	7001	7060	7061	6204
surfaces		0.03	-0.04	0.01	0.02	0.00	0.01	0.00	0.00	0.00	-0.16
Telescope M1 emissivity	k_36	-0.03 0.03	0.05 0.00	-0.03 0.01	0.02 0.02	0.00 0.01	0.00 0.00	0.00 0.00	0.00 0.00	0.00 0.00	-0.02 0.01
Emissivity of radiating struts	-	-0.03 0.03	0.01 0.03	-0.05 0.02	0.00 0.06	-0.02 -0.06	0.00 0.00	0.00 0.00	0.00 0.00	0.00 0.00	0.02 0.06

Table 6.3-4: In-Orbit Sensitivities for CVV external elements (HSS, SVM TS)

		HTT	mdot	HOT	OBA	TS1	TS2	TS3
Reference value		1.659	2.342	19.685	12.999	34.216	45.434	54.843
Overall uncertainty	pos neg	0.040 -0.044	0.162 -0.235	1.478 -1.655	0.525 -0.564	0.871 -1.473	1.303 -2.418	1.766 -3.219
HTT temp (dp) uncertainty	1.5mbar 1.5mbar							
HTT MLI conductance	-50% 50%							
TS1 MLI conductance	-50% 50%							
TS2 MLI conductance	-50% 50%							
TS3 MLI conductance	-50% 50%							
HTT bones	-20% 20%							
inner tank suspension	-20% 20%							
TS 1/2 tank susp.	-20% 20%							
TS 2/3 tank susp.	-20% 20%							
outer tank suspension	-20% 20%							
CVV int. harness conductance (=k_9)	-15% 15%							
Int. harness dissipation	-20% 20%							
He vapourisation heat	-1% 1%							
Stycast comb at TS1	-90% 90%							

		HTT	mdot	HOT	OBA	TS1	TS2	TS3
Stycast comb at OBP	-90% 90%							
CVV MLI conductance	-50% 50%							
Sunshield MLI cond.	50%							
Sunshade MLI cond.	50%							
Updated HSS MLI def.	n/a							
SVM shield MLI emiss.	0.03							
CVV strut conductance	-20% 20%							
HSS strut conductance	-20% 20%							
CVV ext. harness conductance (=k_28)	-15% 15%							
Ext. harness dissipation	-15% 15%							
Sunshade emissivity	-0.03 0.03							
Solar generator emissivity	-0.03 0.03							
Sunshade OSR absorptivity	-0.03 0.03							
Solar generator absorptivity	-0.03 0.03							
LOU strut conductance	-20% 20%							
MLI IR specularity	-20% 20%							
Emissivity of radiator surfaces	-0.03 0.03							
Telescope M1 emissivity	-0.03 0.03							
Emissivity of radiating struts	-0.03 0.03							

Table 6.3-5: Graphical representation of In-Orbit Sensitivities for CVV internal elements

		CVV	SVM-TS	Telescope	LOU_BP	HTT_Heat
Reference value		67.419	131.010	84.961	130.217	53.547
Overall uncertainty	pos	1.962	2.141	5.378	2.561	3.785
	neg	-3.837	-5.453	-16.296	-6.500	-5.491
HTT temp (dp) uncertainty	1.5mbar 1.5mbar					
HTT MLI conductance	-50% 50%					
TS1 MLI conductance	-50% 50%					
TS2 MLI conductance	-50% 50%					
TS3 MLI conductance	-50% 50%					
HTT bones	-20% 20%					
inner tank suspension	-20% 20%					
TS 1/2 tank susp.	-20% 20%					
TS 2/3 tank susp.	-20% 20%					
outer tank suspension	-20% 20%					
CVV int. harness conductance (=k_9)	-15% 15%					
Int. harness dissipation	-20% 20%					
He vapourisation heat	-1% 1%					
Stycast comb at TS1	-90% 90%					
Stycast comb at OBP	-90% 90%					
CVV MLI conductance	-50% 50%	 				
Sunshield MLI conductance	50%					
Sunshade MLI conductance	50%					
Updated HSS MLI definition	n/a					
SVM shield MLI emissivity	0.03					
CVV strut conductance	-20% 20%	 				
HSS strut conductance	-20%					

		CVV	SVM-TS	Telescope	LOU_BP	HTT_Heat
	20%					
CVV ext. harness conductance (=k_28)	-15% 15%					
Ext. harness dissipation	-15% 15%					
Sunshade emissivity	-0.03 0.03					
Solar generator emissivity	-0.03 0.03					
Sunshade OSR absorptivity	-0.03 0.03					
solar generator absorptivity	-0.03 0.03					
LOU strut conductance	-20% 20%					
MLI IR specularity	-20% 20%	 				
Emissivity of radiator surfaces	-0.03 0.03					
Telescope M1 emissivity	-0.03 0.03			 		
Emissivity of radiating struts	-0.03 0.03					

Table 6.3-6: Graphical representation of In-Orbit Sensitivities for CVV external elements (CVV, SVM TS, Tel., LOU)

	label	Vari- ation	L0							
			724	723	761	762	814	815	816	949
Reference value			1.679	1.683	1.682	1.665	1.679	1.701	1.663	1.979
Overall uncertainty	pos		0.040	0.040	0.040	0.040	0.040	0.040	0.040	0.050
	neg		-0.044	-0.044	-0.044	-0.044	-0.044	-0.044	-0.044	-0.054
HTT temp (dp) uncertainty		1.5mbar	0.0363	0.0363	0.0363	0.0363	0.0363	0.0363	0.0363	0.0363
		1.5mbar	-0.0409	-0.0409	-0.0409	-0.0409	-0.0409	-0.0409	-0.0409	-0.0409
HTT MLI conductance	k_1	-50%	-0.0001	-0.0001	-0.0001	-0.0001	-0.0001	-0.0001	-0.0001	0.0010
		50%	-0.0001	0.0000	0.0000	-0.0001	0.0000	-0.0001	0.0000	-0.0001
TS1 MLI conductance	k_2a	-50%	-0.0009	-0.0009	-0.0010	-0.0010	-0.0008	-0.0009	-0.0010	0.0011
		50%	0.0003	0.0003	0.0003	0.0003	0.0003	0.0003	0.0003	0.0001
TS2 MLI conductance	k_2b	-50%	-0.0013	-0.0013	-0.0013	-0.0014	-0.0013	-0.0013	-0.0014	-0.0005
		50%	0.0009	0.0009	0.0009	0.0010	0.0009	0.0009	0.0010	0.0008
TS3 MLI conductance	k_2c	-50%	-0.0024	-0.0024	-0.0025	-0.0026	-0.0024	-0.0024	-0.0025	-0.0012
		50%	0.0017	0.0017	0.0017	0.0017	0.0016	0.0016	0.0017	0.0013

	label	Vari- ation	L0							
			724	723	761	762	814	815	816	949
HTT bones	k_3	-20% 20%	-0.0006 0.0010	-0.0006 0.0010	-0.0008 0.0012	-0.0009 0.0013	-0.0002 0.0007	-0.0005 0.0009	-0.0009 0.0013	0.0097 -0.0082
inner tank suspension	k_4	-20% 20%	-0.0014 0.0013	-0.0014 0.0013	-0.0015 0.0014	-0.0016 0.0015	-0.0014 0.0013	-0.0014 0.0013	-0.0016 0.0015	-0.0003 0.0006
TS 1/2 tank susp.	k_5	-20% 20%	-0.0015 0.0019	-0.0015 0.0019	-0.0017 0.0020	-0.0017 0.0021	-0.0014 0.0017	-0.0015 0.0018	-0.0017 0.0021	0.0023 -0.0016
TS 2/3 tank susp.	k_6	-20% 20%	-0.0021 0.0020	-0.0021 0.0020	-0.0022 0.0020	-0.0022 0.0021	-0.0021 0.0020	-0.0021 0.0020	-0.0022 0.0021	-0.0008 0.0014
outer tank suspension	k_7	-20% 20%	-0.0021 0.0017	-0.0021 0.0017	-0.0021 0.0017	-0.0022 0.0017	-0.0020 0.0017	-0.0021 0.0017	-0.0022 0.0017	-0.0009 0.0017
CVV int. harness conductance (=k_9)	k_8	-15% 15%	-0.0108 0.0110	-0.0107 0.0109	-0.0104 0.0106	-0.0107 0.0108	-0.0112 0.0114	-0.0108 0.0110	-0.0107 0.0109	-0.0302 0.0296
Int. harness dissipation	k_10	-20% 20%	-0.0012 0.0017	-0.0012 0.0017	-0.0010 0.0016	-0.0010 0.0016	-0.0013 0.0019	-0.0012 0.0017	-0.0010 0.0016	-0.0067 0.0071
He vapourisation heat	k_11	-1% 1%	0.0008 -0.0003	0.0008 -0.0002	0.0009 -0.0003	0.0009 -0.0004	0.0007 -0.0001	0.0008 -0.0002	0.0009 -0.0003	-0.0025 0.0030
CVV MLI conductance	k_21	-50% 50%	-0.0037 0.0036	-0.0036 0.0035	-0.0037 0.0036	-0.0038 0.0036	-0.0036 0.0035	-0.0036 0.0035	-0.0038 0.0037	-0.0031 0.0032
Sunshield MLI conductance	k_22	50%	0.0073	0.0073	0.0073	0.0075	0.0073	0.0072	0.0075	0.0069
Sunshade MLI conductance	k_23	50%	0.0023	0.0023	0.0021	0.0022	0.0024	0.0023	0.0022	0.0038
Updated HSS MLI definition	-	n/a	-0.0091	-0.0090	-0.0086	-0.0088	-0.0092	-0.0088	-0.0087	-0.0137
SVM shld MLI emis.	k_24	0.03	0.0021	0.0021	0.0021	0.0021	0.0021	0.0021	0.0021	0.0032
CVV strut conductance	k_25	-20% 20%	-0.0055 0.0058	-0.0055 0.0057	-0.0055 0.0058	-0.0057 0.0059	-0.0054 0.0057	-0.0054 0.0057	-0.0057 0.0059	-0.0046 0.0048
HSS strut conductance	k_26	-20% 20%	-0.0019 0.0019	-0.0019 0.0019	-0.0019 0.0018	-0.0019 0.0019	-0.0019 0.0019	-0.0019 0.0018	-0.0019 0.0019	-0.0011 0.0022
CVV ext. harness conductance (=k_28)	k_27	-15% 15%	-0.0024 0.0025	-0.0023 0.0025	-0.0024 0.0025	-0.0024 0.0026	-0.0023 0.0025	-0.0023 0.0025	-0.0024 0.0026	-0.0020 0.0027
Ext. harness dissipation	k_29	-15% 15%	-0.0001 0.0001	-0.0001 0.0001	-0.0001 0.0001	-0.0001 0.0001	-0.0001 0.0001	-0.0001 0.0001	-0.0001 0.0001	0.0000 0.0000
Sunshade emissivity	k_32	-0.03 0.03	0.0005 -0.0003	0.0005 -0.0003	0.0005 -0.0003	0.0005 -0.0003	0.0005 -0.0003	0.0005 -0.0003	0.0005 -0.0003	0.0007 -0.0003
Solar generator emissivity	k_33	-0.03 0.03	0.0011 -0.0009	0.0011 -0.0008	0.0011 -0.0008	0.0011 -0.0009	0.0011 -0.0008	0.0011 -0.0008	0.0011 -0.0009	0.0011 -0.0005
Sunshade OSR absorptivity	k_34	-0.03 0.03	-0.0008 0.0010	-0.0008 0.0010	-0.0007 0.0009	-0.0007 0.0009	-0.0008 0.0011	-0.0008 0.0010	-0.0007 0.0009	-0.0015 0.0023
Solar generator absorptivity	k_35	-0.03 0.03	-0.0009 0.0009	-0.0009 0.0009	-0.0009 0.0009	-0.0009 0.0010	-0.0009 0.0009	-0.0009 0.0009	-0.0009 0.0010	-0.0005 0.0009
LOU strut	k_38	-20%	-0.0004	-0.0004	-0.0004	-0.0004	-0.0004	-0.0004	-0.0004	-0.0003

	label	Vari- ation	L0							
			724	723	761	762	814	815	816	949
conductance		20%	0.0004	0.0004	0.0004	0.0004	0.0004	0.0004	0.0004	0.0003
MLI IR specularity	k_30	-20%	0.0045	0.0045	0.0044	0.0045	0.0045	0.0044	0.0044	0.0052
		20%	-0.0041	-0.0040	-0.0040	-0.0041	-0.0041	-0.0040	-0.0040	-0.0048
Emissivity of radiator surfaces	k_31	-0.03	0.0015	0.0015	0.0015	0.0015	0.0014	0.0014	0.0015	0.0010
		0.03	-0.0015	-0.0015	-0.0015	-0.0016	-0.0015	-0.0015	-0.0016	-0.0008
Telescope M1 emissivity	k_36	-0.03	0.0007	0.0007	0.0007	0.0007	0.0007	0.0007	0.0007	0.0008
		0.03	-0.0004	-0.0004	-0.0004	-0.0004	-0.0004	-0.0004	-0.0004	-0.0003
Emissivity of radiating struts	-	-0.03	0.0000	0.0000	0.0000	0.0000	0.0000	0.0000	0.0000	0.0001
		0.03	0.0001	0.0001	0.0001	0.0001	0.0001	0.0001	0.0001	0.0001

Table 6.3-7: In-Orbit Sensitivities for Instrument Interface nodes – Level 0

	label	Vari- ation	L1					L2			
			781	782	783	800	939	371	381	315	919
Reference value			2.708	3.044	3.201	4.771	5.923	12.990	13.030	13.010	12.994
Overall uncertainty	pos neg		0.062	0.074	0.081	0.153	0.213	0.508	0.509	0.509	0.505
			-0.064	-0.075	-0.084	-0.155	-0.199	-0.566	-0.567	-0.567	-0.563
HTT temp (dp) uncertainty		1.5mbar	0.036	0.036	0.036	0.036	0.036	0.036	0.036	0.036	0.036
		1.5mbar	-0.041	-0.041	-0.041	-0.041	-0.041	-0.041	-0.041	-0.041	-0.041
HTT MLI conductance	k_1	-50%	0.002	0.003	0.003	0.008	0.013	0.017	0.017	0.017	0.017
		50%	0.000	0.000	0.000	-0.001	-0.001	0.000	0.000	0.000	0.000
TS1 MLI conductance	k_2a	-50%	0.007	0.009	0.010	0.021	0.029	0.023	0.022	0.023	0.022
		50%	-0.002	-0.002	-0.002	-0.004	-0.005	0.000	0.000	0.000	0.000
TS2 MLI conductance	k_2b	-50%	0.002	0.004	0.003	0.009	0.015	0.000	0.000	0.000	0.000
		50%	-0.001	-0.001	-0.001	-0.003	-0.003	0.001	0.001	0.001	0.001
TS3 MLI conductance	k_2c	-50%	0.004	0.006	0.006	0.014	0.023	-0.002	-0.003	-0.002	-0.002
		50%	-0.002	-0.002	-0.002	-0.006	-0.006	0.001	0.002	0.002	0.001
HTT bones	k_3	-20%	0.024	0.031	0.033	0.074	0.111	0.174	0.173	0.173	0.171
		20%	-0.021	-0.027	-0.028	-0.066	-0.099	-0.164	-0.163	-0.163	-0.161
inner tank suspension	k_4	-20%	0.008	0.010	0.010	0.020	0.024	-0.001	-0.001	0.000	0.000
		20%	-0.006	-0.009	-0.009	-0.017	-0.017	0.002	0.002	0.001	0.001
TS 1/2 tank susp.	k_5	-20%	0.014	0.019	0.020	0.041	0.056	0.041	0.041	0.041	0.041
		20%	-0.012	-0.016	-0.017	-0.037	-0.049	-0.042	-0.042	-0.042	-0.042
TS 2/3 tank susp.	k_6	-20%	0.005	0.007	0.007	0.016	0.025	0.000	0.000	0.000	0.000
		20%	-0.003	-0.004	-0.004	-0.010	-0.012	0.002	0.003	0.002	0.002
outer tank suspension	k_7	-20%	0.004	0.005	0.005	0.013	0.021	0.000	-0.001	-0.001	-0.001
		20%	-0.001	-0.002	-0.002	-0.004	-0.005	0.014	0.015	0.014	0.014
CVV int. harness conduct. (=k_9)	k_8	-15%	-0.026	-0.030	-0.036	-0.091	-0.139	-0.488	-0.489	-0.489	-0.485
		15%	0.028	0.033	0.039	0.092	0.135	0.451	0.452	0.452	0.449
Int. harness	k_10	-20%	-0.016	-0.021	-0.023	-0.039	-0.054	-0.116	-0.115	-0.115	-0.115

	label	Variation	L1					L2			
			781	782	783	800	939	371	381	315	919
dissipation		20%	0.016	0.021	0.024	0.039	0.054	0.109	0.108	0.108	0.108
He vapourisation heat	k_11	-1%	-0.008	-0.010	-0.011	-0.026	-0.037	-0.057	-0.056	-0.057	-0.056
		1%	0.008	0.011	0.012	0.025	0.037	0.050	0.049	0.050	0.049
CVV MLI conductance	k_21	-50%	0.001	0.002	0.001	0.006	0.016	-0.023	-0.024	-0.024	-0.023
		50%	0.000	-0.001	0.000	-0.004	-0.011	0.022	0.023	0.023	0.022
Sunshield MLI conductance	k_22	50%	0.004	0.005	0.007	0.004	-0.014	0.039	0.041	0.040	0.040
Sunshade MLI conductance	k_23	50%	0.014	0.018	0.021	0.034	0.028	0.028	0.028	0.028	0.028
Updated HSS MLI definition	-	n/a	-0.025	-0.035	-0.046	-0.070	-0.016	-0.176	-0.180	-0.179	-0.178
SVM shield MLI emis.	k_24	0.03	0.006	0.008	0.009	0.010	0.012	0.025	0.025	0.025	0.025
CVV strut conductance	k_25	-20%	0.002	0.003	0.003	0.011	0.025	-0.032	-0.033	-0.033	-0.033
		20%	-0.001	-0.002	-0.001	-0.009	-0.022	0.023	0.024	0.024	0.024
HSS strut conductance	k_26	-20%	0.001	0.001	0.001	0.005	0.012	-0.002	-0.003	-0.002	-0.003
		20%	0.001	0.001	0.002	0.002	0.001	0.018	0.018	0.018	0.018
CVV ext. harness conduct. (=k_28)	k_27	-15%	0.001	0.002	0.002	0.005	0.011	-0.017	-0.017	-0.017	-0.017
		15%	0.000	0.000	0.000	-0.001	-0.004	0.021	0.021	0.021	0.021
Ext. harness dissipation	k_29	-15%	0.000	0.000	0.000	0.000	0.000	0.000	0.000	0.000	0.000
		15%	0.000	0.000	0.000	0.000	0.000	0.000	0.000	0.000	0.000
Sunshade emissivity	k_32	-0.03	0.002	0.002	0.003	0.004	0.005	0.001	0.001	0.001	0.001
		0.03	-0.001	-0.001	-0.002	-0.002	-0.001	0.000	0.000	0.000	0.000
Solar generator emissivity	k_33	-0.03	0.000	0.001	0.001	0.000	0.003	0.001	0.002	0.001	0.001
		0.03	0.000	0.000	0.000	0.001	0.004	0.000	0.000	0.000	0.000
Sunshade OSR absorptivity	k_34	-0.03	-0.006	-0.008	-0.009	-0.016	-0.012	-0.018	-0.018	-0.018	-0.018
		0.03	0.007	0.010	0.011	0.019	0.018	0.023	0.023	0.023	0.023
Solar generator absorptivity	k_35	-0.03	0.000	0.000	0.000	0.002	0.004	0.000	0.000	0.000	0.000
		0.03	0.000	0.000	0.001	0.000	0.002	0.001	0.001	0.001	0.001
LOU strut conductance	k_38	-20%	0.000	0.000	0.000	0.001	0.002	0.000	0.000	0.000	0.000
		20%	0.000	0.000	0.000	-0.001	-0.002	0.000	0.000	0.000	0.000
MLI IR specularity	k_30	-20%	0.013	0.017	0.019	0.022	0.011	0.032	0.033	0.033	0.033
		20%	-0.008	-0.010	-0.011	-0.020	-0.008	-0.040	-0.041	-0.041	-0.041
Emissivity of radiator surfaces	k_31	-0.03	0.002	0.003	0.003	-0.002	-0.006	0.000	0.000	0.000	0.000
		0.03	0.004	0.006	0.007	0.009	0.014	-0.001	-0.001	-0.001	-0.001
Telescope M1 emissivity	k_36	-0.03	0.002	0.003	0.004	0.004	0.004	0.001	0.001	0.001	0.001
		0.03	0.000	0.000	-0.001	-0.001	0.001	0.000	0.000	0.000	0.000
Emissivity of radiating struts	-	-0.03	0.000	0.000	0.000	0.001	0.001	0.000	0.000	0.000	0.000
		0.03	0.000	0.001	0.001	0.001	0.001	0.000	0.000	0.000	0.000

Table 6.3-8: In-Orbit Sensitivities for Instrument Interface nodes – Level 1 & 2

	label	variation	L3		LOU	Telescope		mdot
			831	832	4201	8001	8050	5900
Reference value			13.609	13.653	130.159	84.971	82.316	2.342
Overall uncertainty	pos		0.502	0.507	2.560	5.378	4.662	0.162
	neg		-0.538	-0.533	-6.498	-16.299	-15.034	-0.235
HTT temp (dp) uncertainty		1.5mbar 1.5mbar	0.036 -0.041	0.036 -0.041	0 0	0 0	0 0	0 0
HTT MLI conductance	k_1	-50% 50%	0.018 0.000	0.018 0.000	0.0000 0.0000	-0.0019 -0.0005	-0.0016 -0.0004	-0.001 0.000
TS1 MLI conductance	k_2a	-50% 50%	0.024 0.000	0.024 0.001	0.0001 0.0000	0.0011 -0.0026	0.0010 -0.0022	-0.012 0.004
TS2 MLI conductance	k_2b	-50% 50%	0.002 0.003	0.003 0.005	0.0001 0.0000	0.0001 0.0001	0.0001 0.0001	-0.014 0.010
TS3 MLI conductance	k_2c	-50% 50%	0.001 0.003	0.002 0.006	0.0002 -0.0001	0.0027 -0.0018	0.0023 -0.0015	-0.024 0.016
HTT bones	k_3	-20% 20%	0.173 -0.157	0.175 -0.154	0.0001 -0.0001	0.0029 -0.0006	0.0025 -0.0005	-0.011 0.015
inner tank suspension	k_4	-20% 20%	0.005 -0.002	0.005 -0.001	0.0001 -0.0001	0.0020 -0.0018	0.0017 -0.0015	-0.018 0.017
TS 1/2 tank susp.	k_5	-20% 20%	0.047 -0.042	0.049 -0.039	0.0001 -0.0001	0.0041 -0.0018	0.0035 -0.0015	-0.021 0.023
TS 2/3 tank susp.	k_6	-20% 20%	0.003 0.003	0.004 0.006	0.0002 -0.0001	0.0011 -0.0016	0.0010 -0.0014	-0.024 0.022
outer tank suspension	k_7	-20% 20%	0.002 0.013	0.003 0.014	0.0002 -0.0001	0.0014 -0.0049	0.0012 -0.0041	-0.021 0.017
CVV int. harness conductance (=k_9)	k_8	-15% 15%	-0.470 0.445	-0.466 0.447	0.0007 -0.0007	0.0171 -0.0145	0.0144 -0.0122	-0.115 0.116
Int. harness dissipation	k_10	-20% 20%	-0.106 0.105	-0.103 0.107	0.0000 0.0000	0.0014 0.0007	0.0012 0.0006	-0.011 0.016
He vapourisation heat	k_11	-1% 1%	-0.053 0.052	-0.050 0.055	0.0000 0.0000	0.0002 0.0018	0.0002 0.0016	0.010 -0.005
CVV MLI conductance	k_21	-50% 50%	-0.016 0.019	-0.013 0.019	0.0081 -0.0076	-0.0945 0.0876	-0.0797 0.0739	-0.031 0.030
Sunshield MLI conductance	k_22	50%	0.036	0.038	2.3895	3.3136	2.7819	0.062
Sunshade MLI conductance	k_23	50%	0.029	0.031	0.1780	2.0105	2.0095	0.019
Updated HSS MLI definition	-	n/a	-0.157	-0.159	-6.4375	-16.112	-14.879	-0.185
SVM shield MLI emis.	k_24	0.03	0.030	0.035	-0.0049	0.0474	0.0374	0.017
CVV strut conductance	k_25	-20% 20%	-0.023 0.021	-0.021 0.024	-0.0114 0.0105	-0.1684 0.1619	-0.1422 0.1365	-0.046 0.049
HSS strut	k_26	-20%	0.000	0.001	-0.0469	-0.1177	-0.0995	-0.016

	label	variation	L3		LOU	Telescope		mdot
			831	832	4201	8001	8050	5900
conductance		20%	0.017	0.018	0.0393	0.1062	0.0897	0.016
CVV ext. harness conductance (=k_28)	k_27	-15%	-0.011	-0.009	-0.7902	-0.1022	-0.0871	-0.020
		15%	0.019	0.020	0.8016	0.1137	0.0973	0.022
Ext. harness dissipation	k_29	-15%	0.000	0.000	-0.0117	-0.0016	-0.0013	0.000
		15%	0.000	0.000	0.0117	0.0015	0.0013	0.001
Sunshade emissivity	k_32	-0.03	0.003	0.006	0.0228	0.2380	0.2359	0.005
		0.03	0.000	0.000	-0.0210	-0.2193	-0.2174	-0.003
Solar generator emissivity	k_33	-0.03	0.004	0.006	0.2752	0.3926	0.3319	0.009
		0.03	0.001	0.001	-0.2577	-0.3700	-0.3133	-0.007
Sunshade OSR absorptivity	k_34	-0.03	-0.013	-0.010	-0.0954	-1.0050	-0.9981	-0.006
		0.03	0.022	0.022	0.0946	0.9745	0.9670	0.008
Solar generator absorptivity	k_35	-0.03	0.001	0.001	-0.2684	-0.3862	-0.3271	-0.007
		0.03	0.002	0.003	0.2665	0.3809	0.3220	0.008
LOU strut conductance	k_38	-20%	0.000	0.000	0.0769	-0.0110	-0.0093	-0.003
		20%	0.000	0.001	-0.0766	0.0110	0.0092	0.004
MLI IR specularity	k_30	-20%	0.031	0.034	0.0740	0.4599	0.4249	0.037
		20%	-0.032	-0.030	-0.0696	-0.3315	-0.3199	-0.034
Emissivity of radiator surfaces	k_31	-0.03	0.000	0.000	0.0224	0.0402	0.0327	0.012
		0.03	0.001	0.002	-0.0070	0.0007	-0.0030	-0.013
Telescope M1 emissivity	k_36	-0.03	0.003	0.006	-0.0153	3.5096	2.9192	0.006
		0.03	0.000	0.000	-0.0152	-2.1319	-1.8006	-0.003
Emissivity of radiating struts	-	-0.03	0.000	0.000	-0.0108	0.0498	0.0437	0.000
		0.03	0.000	0.001	-0.0187	-0.0066	-0.0084	0.001

Table 6.3-9: In-Orbit Sensitivities for Level 3 Instrument Interface nodes, LOU and Telescope

	label	L0							
		724	723	761	762	814	815	816	949
Reference value		1.679	1.683	1.682	1.665	1.679	1.701	1.663	1.979
Overall uncertainty	pos	0.040	0.040	0.040	0.040	0.040	0.040	0.040	0.050
	neg	-0.044	-0.044	-0.044	-0.044	-0.044	-0.044	-0.044	-0.054
HTT temp (dp) uncertainty	1.5mbar 1.5mbar								
HTT MLI conductance	-50% 50%								
TS1 MLI conductance	-50% 50%								
TS2 MLI conductance	-50% 50%								
TS3 MLI conductance	-50% 50%								

	label	L0							
		724	723	761	762	814	815	816	949
HTT bones	-20% 20%								
inner tank suspension	-20% 20%								
TS 1/2 tank susp.	-20% 20%								
TS 2/3 tank susp.	-20% 20%								
outer tank suspension	-20% 20%								
CVV int. harness conduct. (=k_9)	-15% 15%								
Int. harness dissipation	-20% 20%								
He vapourisation heat	-1% 1%								
CVV MLI conductance	-50% 50%								
Sunshield MLI conductance	50%								
Sunshade MLI conductance	50%								
Updated HSS MLI definition	n/a								
SVM shield MLI emiss.	0.03								
CVV strut conductance	-20% 20%								
HSS strut conductance	-20% 20%								
CVV ext. harness conduct. (=k_28)	-15% 15%								
Ext. harness dissipation	-15% 15%								
Sunshade emissivity	-0.03 0.03								
Solar generator emissivity	-0.03 0.03								
Sunshade OSR absorptivity	-0.03 0.03								
Solar generator absorptivity	-0.03 0.03								
LOU strut conductance	-20% 20%								

	label	L0							
		724	723	761	762	814	815	816	949
MLI IR specularity	-20% 20%								
Emissivity of radiator surfaces	-0.03 0.03								
Telescope M1 emissivity	-0.03 0.03								
Emissivity of radiating struts	-0.03 0.03								

Table 6.3-10: Graphical representation of In-Orbit Sensitivities for Instrument Interface nodes – Level 0

	label	L1					L2			
		781	782	783	800	939	371	381	315	919
Reference value		2.708	3.044	3.201	4.771	5.923	12.990	13.030	13.010	12.994
Overall uncertainty	pos neg	0.062 -0.064	0.074 -0.075	0.081 -0.084	0.153 -0.155	0.213 -0.199	0.508 -0.566	0.509 -0.567	0.509 -0.567	0.505 -0.563
HTT temp (dp) uncertainty	1.5mbar 1.5mbar									
HTT MLI conductance	-50% 50%									
TS1 MLI conductance	-50% 50%									
TS2 MLI conductance	-50% 50%									
TS3 MLI conductance	-50% 50%									
HTT bones	-20% 20%									
inner tank suspension	-20% 20%									
TS 1/2 tank susp.	-20% 20%									
TS 2/3 tank susp.	-20% 20%									
outer tank suspension	-20% 20%									
CVV int. harness conduct. (=k_9)	-15% 15%									
Int. harness dissipation	-20% 20%									

	label	L1					L2			
		781	782	783	800	939	371	381	315	919
He vapourisation heat	-1% 1%									
CVV MLI conductance	-50% 50%									
Sunshield MLI conductance	50%									
Sunshade MLI conductance	50%									
Updated HSS MLI definition	n/a									
SVM shield MLI emissivity	0.03									
CVV strut conductance	-20% 20%									
HSS strut conductance	-20% 20%									
CVV ext. harness cond. (=k_28)	-15% 15%									
Ext. harness dissipation	-15% 15%									
Sunshade emissivity	-0.03 0.03									
Solar generator emissivity	-0.03 0.03									
Sunshade OSR absorptivity	-0.03 0.03									
Solar generator absorptivity	-0.03 0.03									
LOU strut conductance	-20% 20%									
MLI IR specularity	-20% 20%									
Emissivity of radiator surfaces	-0.03 0.03									
Telescope M1 emissivity	-0.03 0.03									
Emissivity of radiating struts	-0.03 0.03									

Table 6.3-11: Graphical representation of In-Orbit Sensitivities for Instrument Interface nodes – Level 1 & 2

	label	L3		LOU	Telescope		mdot
		831	832	4201	8001	8050	5900
Reference value		13.609	13.653	130.159	84.971	82.316	2.342
Overall uncertainty	pos	0.502	0.507	2.560	5.378	4.662	0.162
	neg	-0.538	-0.533	-6.498	-16.299	-15.034	-0.235
HTT temp (dp) uncertainty	1.5mbar 1.5mbar						
HTT MLI conductance	-50% 50%						
TS1 MLI conductance	-50% 50%						
TS2 MLI conductance	-50% 50%						
TS3 MLI conductance	-50% 50%						
HTT bones	-20% 20%						
inner tank suspension	-20% 20%						
TS 1/2 tank susp.	-20% 20%						
TS 2/3 tank susp.	-20% 20%						
outer tank suspension	-20% 20%						
CVV int. harness conductance (=k_9)	-15% 15%						
Int. harness dissipation	-20% 20%						
He vapourisation heat	-1% 1%						
CVV MLI conductance	-50% 50%						
Sunshield MLI conduct.	50%						
Sunshade MLI conduct.	50%						
Updated HSS MLI def.	n/a						
SVM shield MLI emiss.	0.03						
CVV strut conductance	-20% 20%						
HSS strut conductance	-20% 20%						
CVV ext. harness conductance (=k_28)	-15% 15%						

	label	L3		LOU	Telescope		mdot
		831	832	4201	8001	8050	5900
Ext. harness dissipation	-15% 15%						
Sunshade emissivity	-0.03 0.03						
Solar generator emissivity	-0.03 0.03						
Sunshade OSR absorptivity	-0.03 0.03						
Solar generator absorptivity	-0.03 0.03						
LOU strut conductance	-20% 20%						
MLI IR specularity	-20% 20%						
Emissivity of radiator surfaces	-0.03 0.03						
Telescope M1 emissivity	-0.03 0.03				 	 	
Emissivity of radiating struts	-0.03 0.03						

Table 6.3-12: Graphical representation of In-Orbit Sensitivities for Level 3 Instrument Interface nodes, LOU and Telescope

In case the solar cells are in shunt mode and all absorbed solar energy is dumped in the Solar Array, the temperature of the center panel increases to 409 K (136°C). This has been calculated for LEOP and Winter Solstice.

6.3.3 Transient Spacecraft Operations

A transient analysis run has been performed simulating a spacecraft rotation from 0° to 30° (z-axis to sun pointing, step function at start) around the y-axis, based on orbit hot conditions. The transient cool-down curves of Telescope, LOU, CVV and HTT in this case are shown in the following figures.

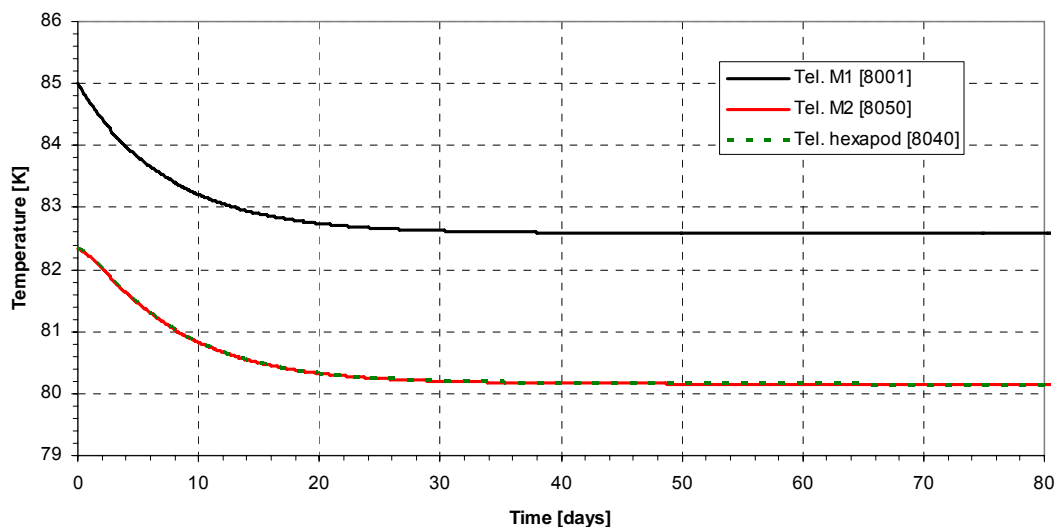

Figure 6.3-6: Transient Cool-Down of Telescope after S/C Rotation 30° around Y-Axis

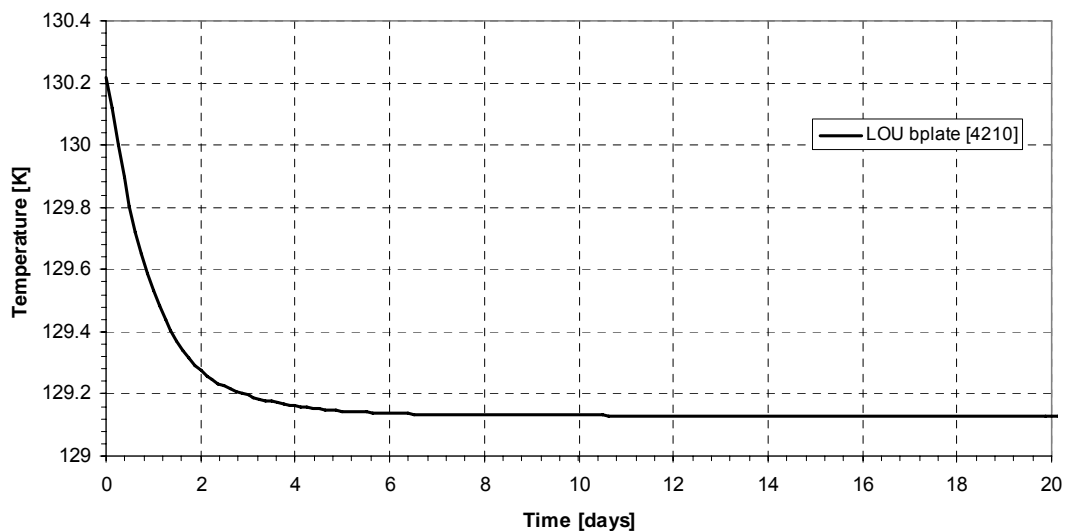

Figure 6.3-7: Transient Cool-Down of LOU Baseplate after S/C Rotation 30° around Y-Axis

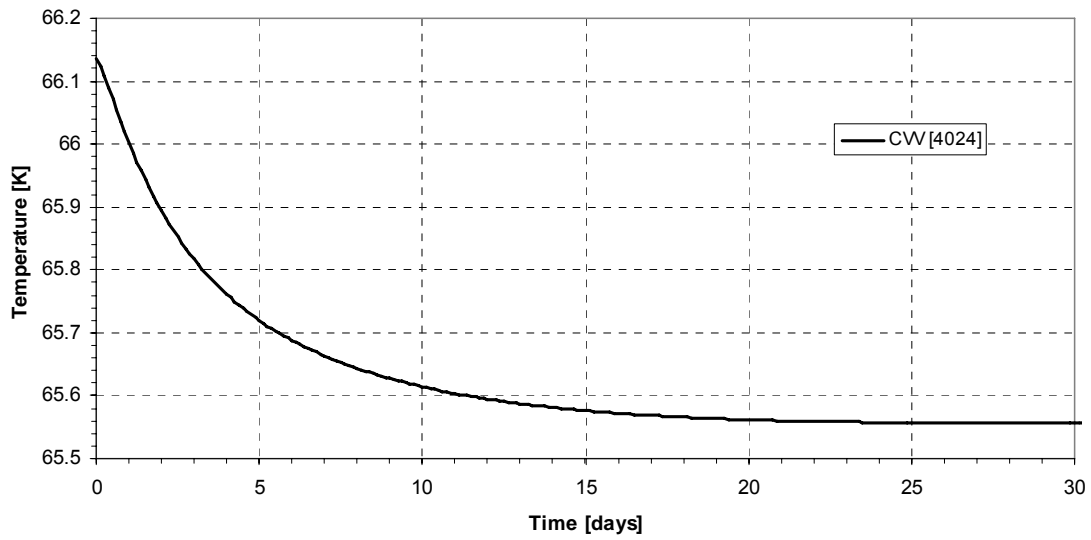

Figure 6.3-8: Transient Cool-Down of CVV after S/C Rotation 30° around Y-Axis

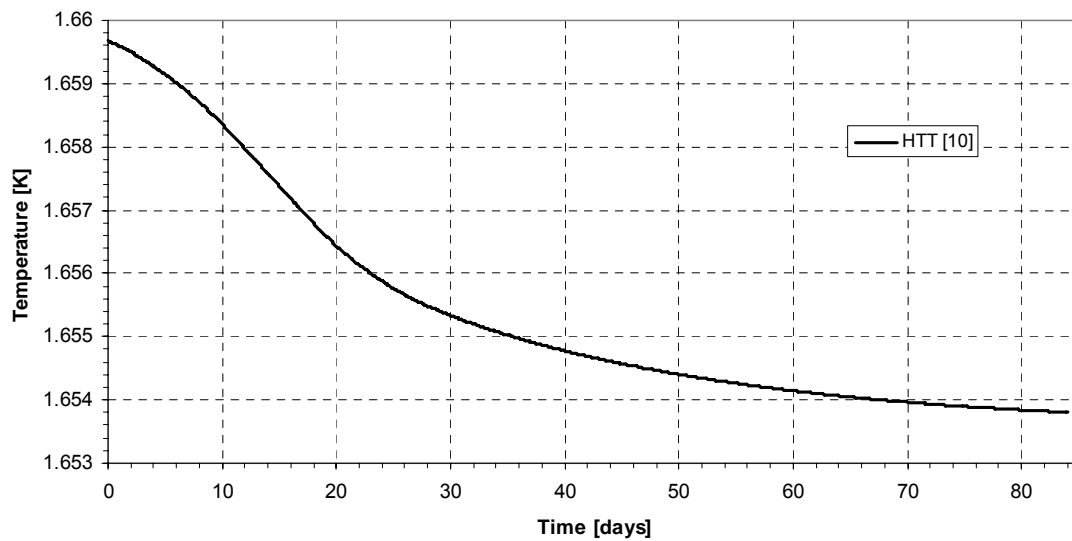

Figure 6.3-9: Transient Cool-Down of HTT after S/C Rotation 30° around Y-Axis

6.4 Instrument Operation in L2 Orbit

The transient temperature and heat flow results for the instrument thermal interface nodes shown in this section are based on the following instrument timeline:

Start conditions (steady state):	Instruments average dissipation
• PACS Photometer Mode (incl. sorption cooler cycle)	48 h
• SPIRE	48 h
• HIFI	48 h
• SPIRE	48 h
• PACS Spectrometer Mode (no sorption cooler cycle)	24 h
• HIFI	48 h
• PACS Spectrometer Mode (no sorption cooler cycle)	24 h

The related instrument dissipation profiles used as input for these calculations are compiled in section 4.5.

The analysis results shown in Section 6.4.1 to 6.4.4 are performed for hot case conditions (acc. to Table 3.2-1) with a remaining He II mass of 35 kg at the beginning of the simulation.

The uncertainties to be taken into account for the different temperature levels are given in Table 6.6-1.

Further analyses have been performed to investigate the effect of cold case conditions at L2 and to compare the results of an almost empty Helium tank (35 kg) with the performance of an almost full Helium tank (300 kg). Those results are shown in Section 6.4.5.

6.4.1 PACS Interface Temperatures and Heat Flows

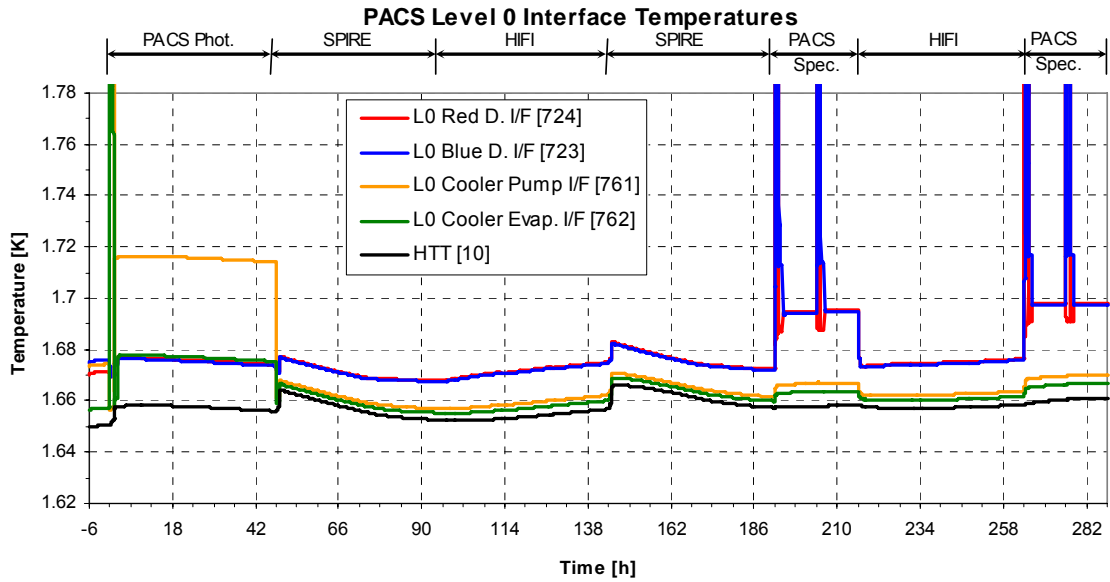

Figure 6.4-1: PACS L0 Interface Temperatures

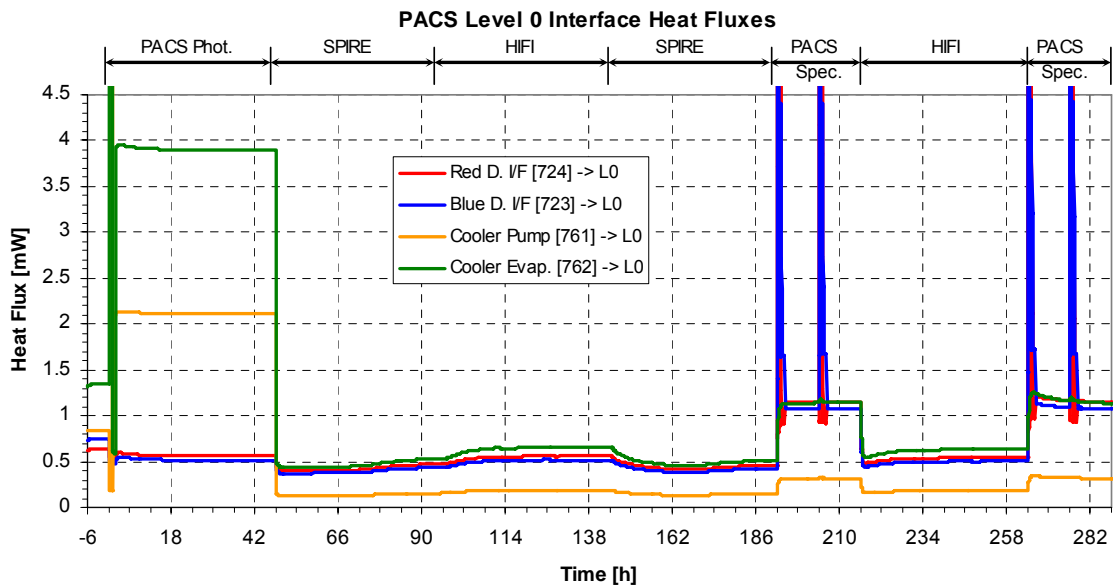

Figure 6.4-2: PACS L0 Interface Heat Flows

PACS Level 0 Interface Temperatures during Recycling

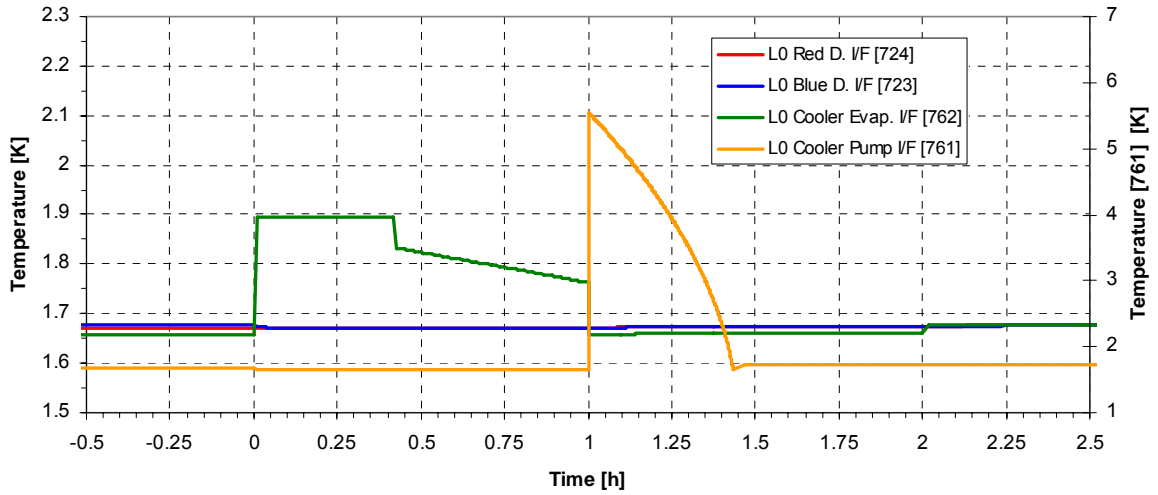

Figure 6.4-3: PACS L0 Interface Temperatures during Recycling

PACS Level 0 Interface Heat Fluxes during Recycling

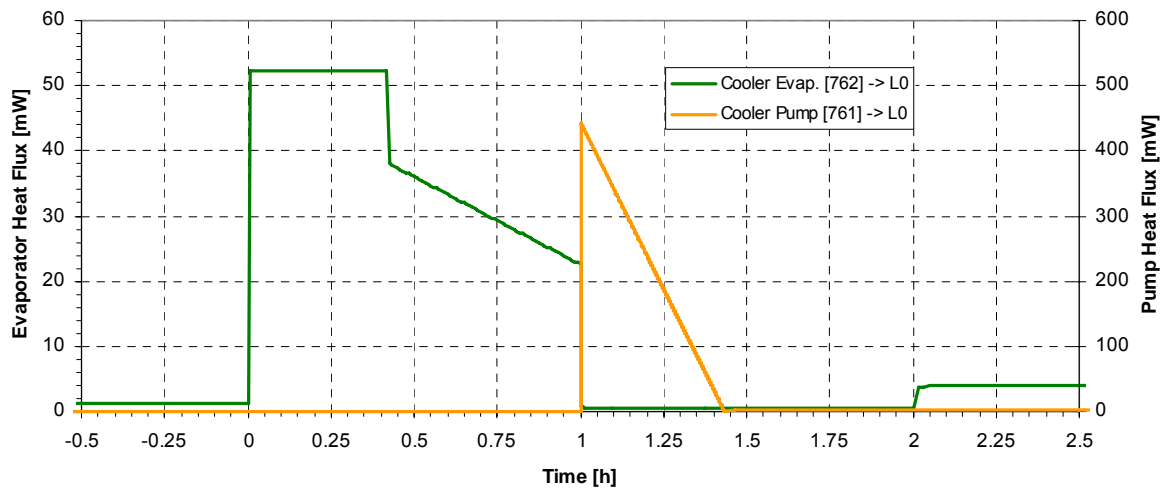

Figure 6.4-4: PACS L0 Interface Heat Flows during Recycling

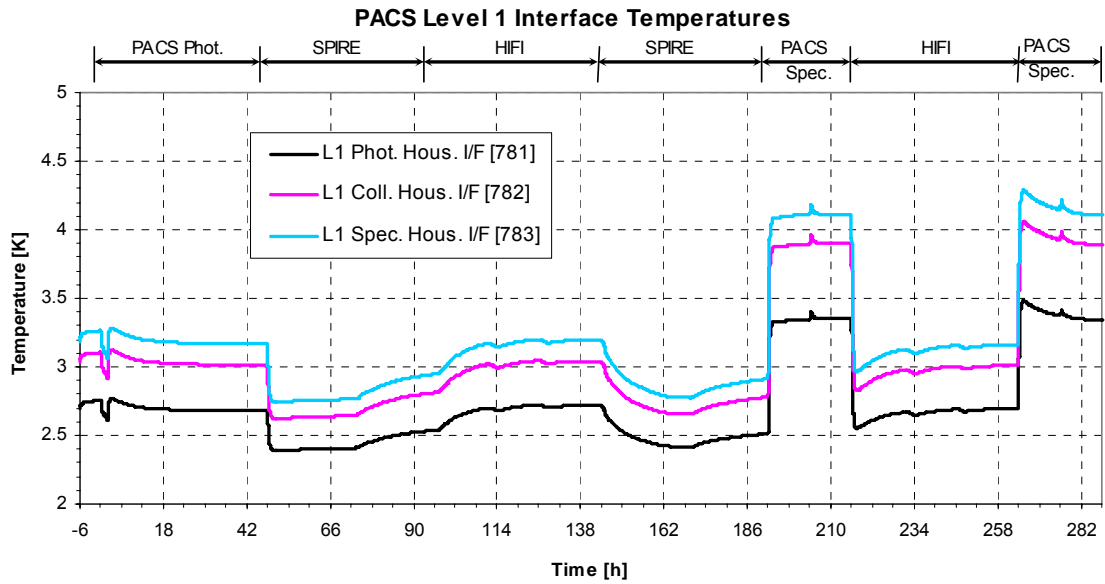

Figure 6.4-5: PACS L1 Interface Temperatures

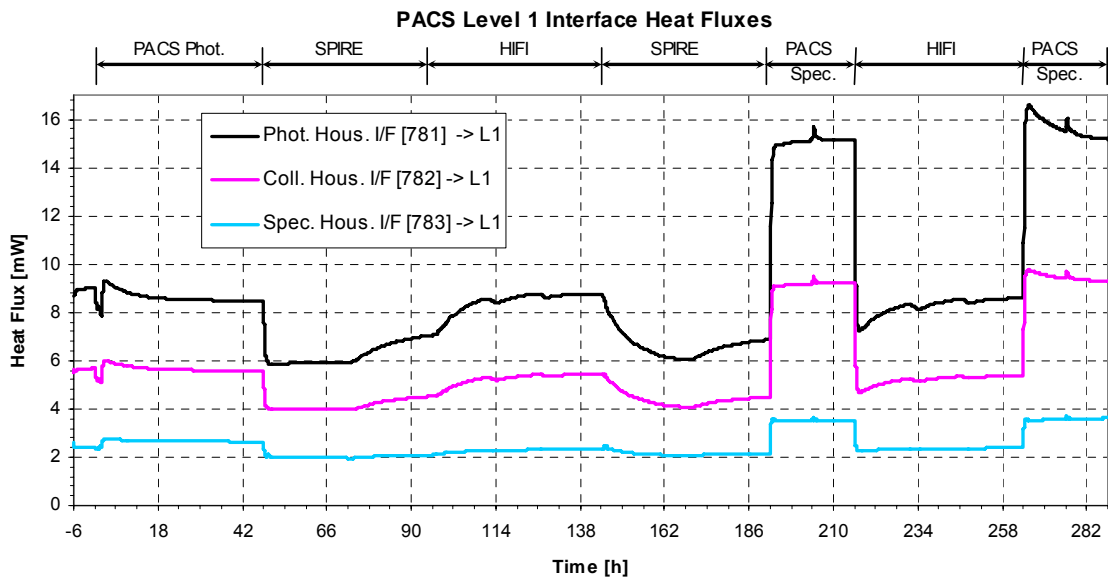

Figure 6.4-6: PACS L1 Interface Heat Flows

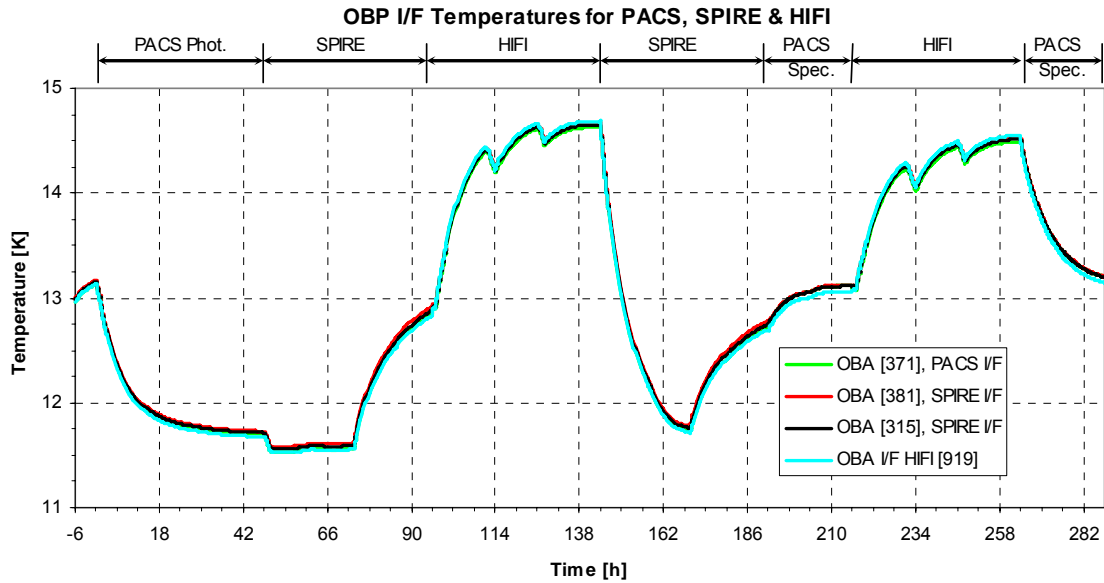

Figure 6.4-7: FPU L2 Interface Temperatures

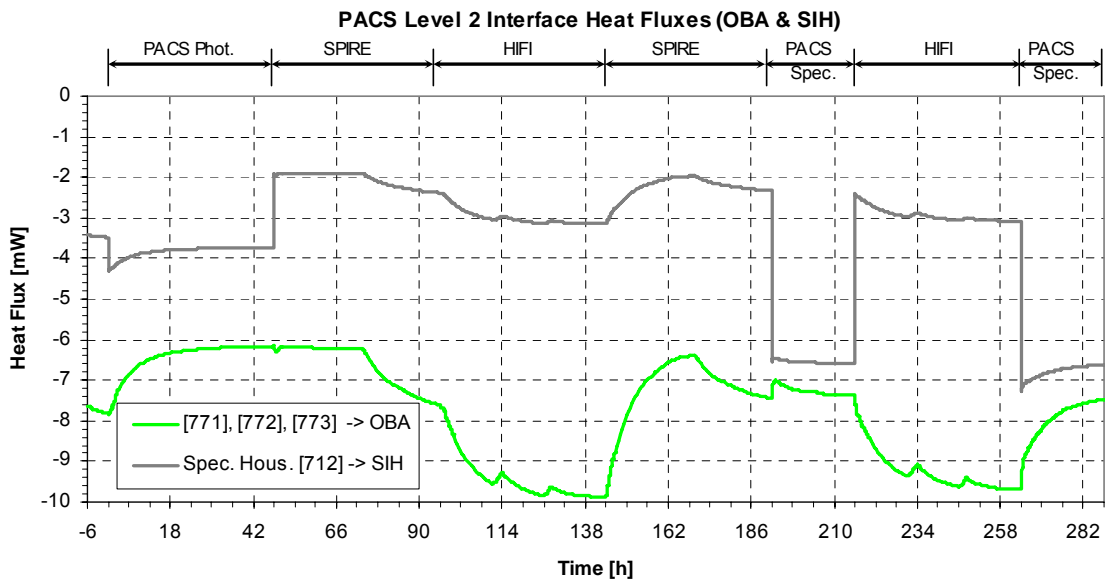

Figure 6.4-8: PACS L2 Interface Heat Fluxes

6.4.2 SPIRE Interface Temperatures and Heat Flows

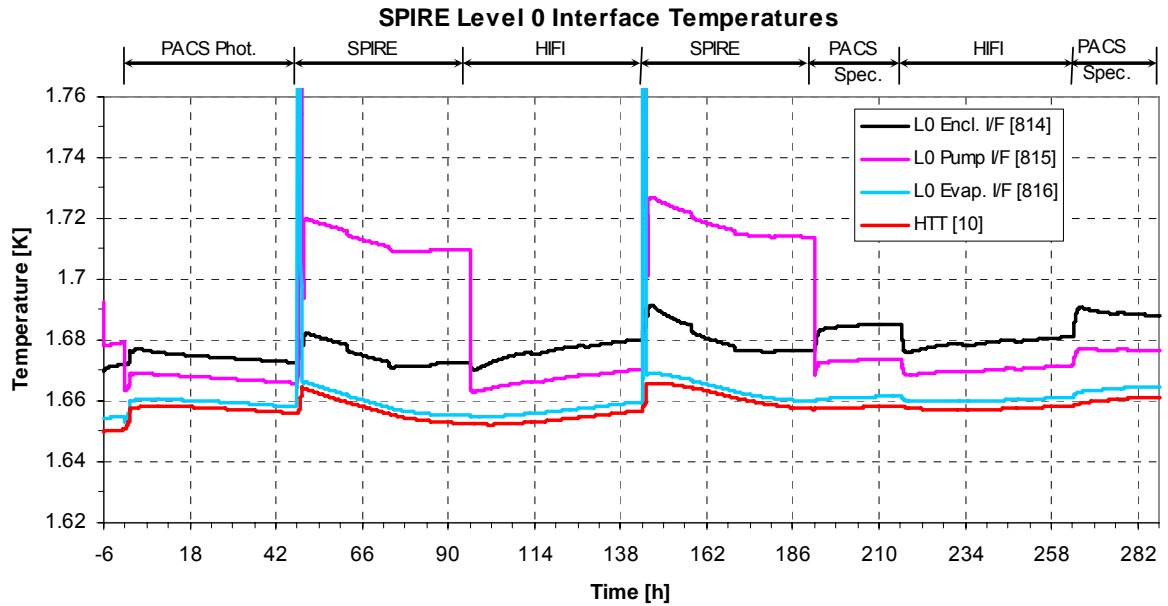

Figure 6.4-9: SPIRE L0 Interface Temperatures

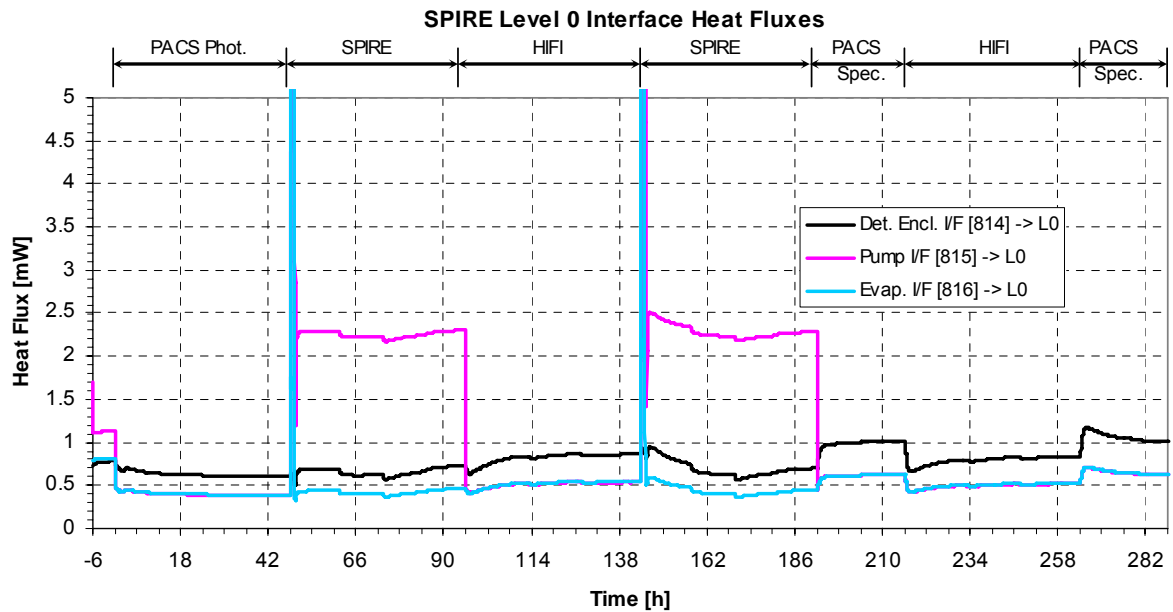

Figure 6.4-10: SPIRE L0 Interface Heat Fluxes

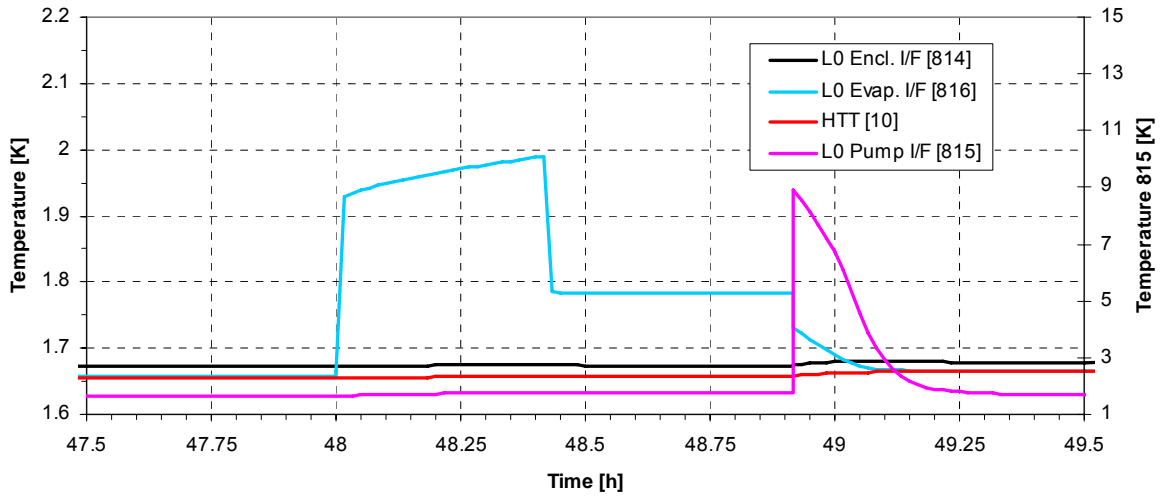

Figure 6.4-11: SPIRE L0 Interface Temperatures during Recycling

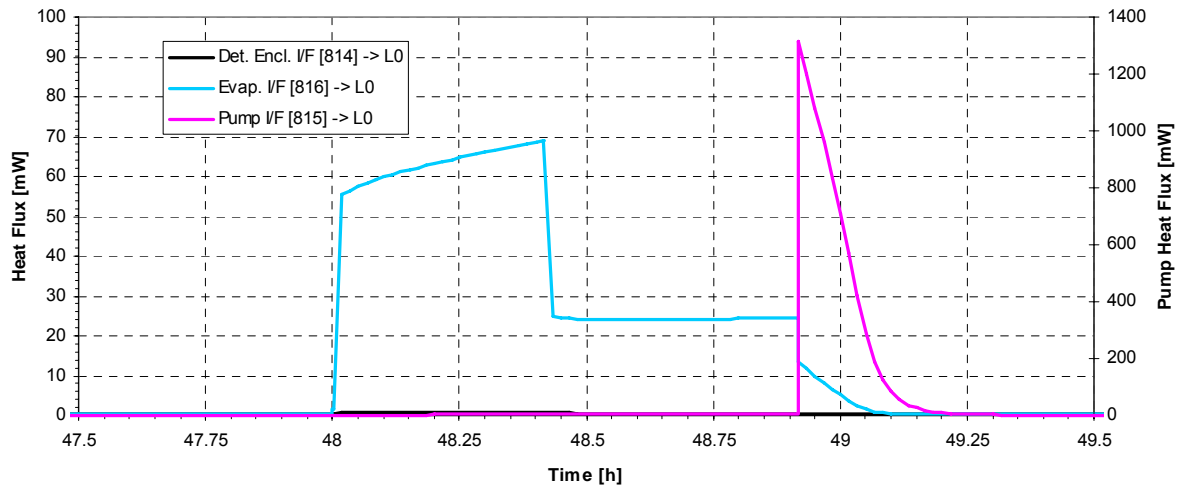

Figure 6.4-12: SPIRE L0 Interface Heat Flows during Recycling

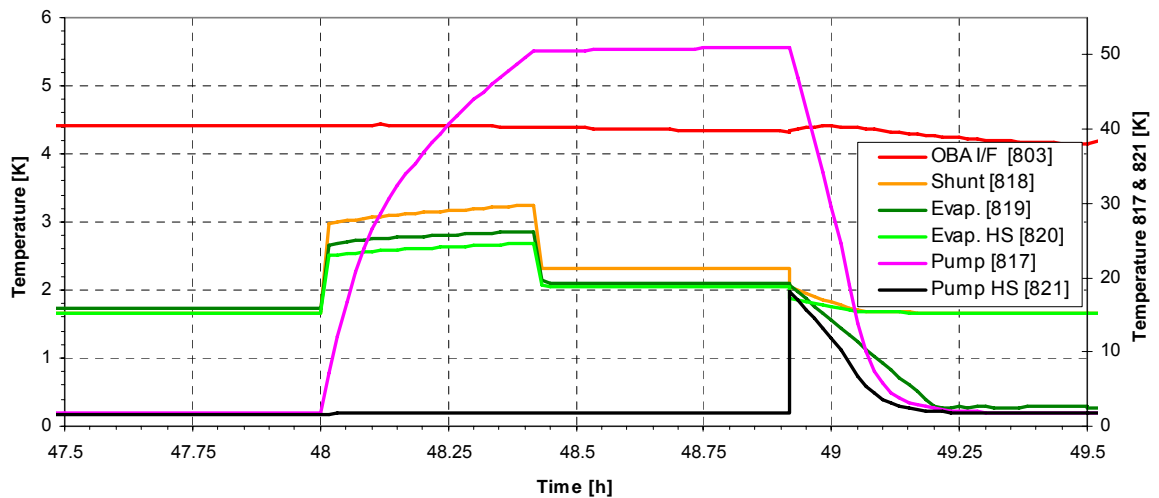

Figure 6.4-13: SPIRE Cooler Temperatures during Recycling (for information)

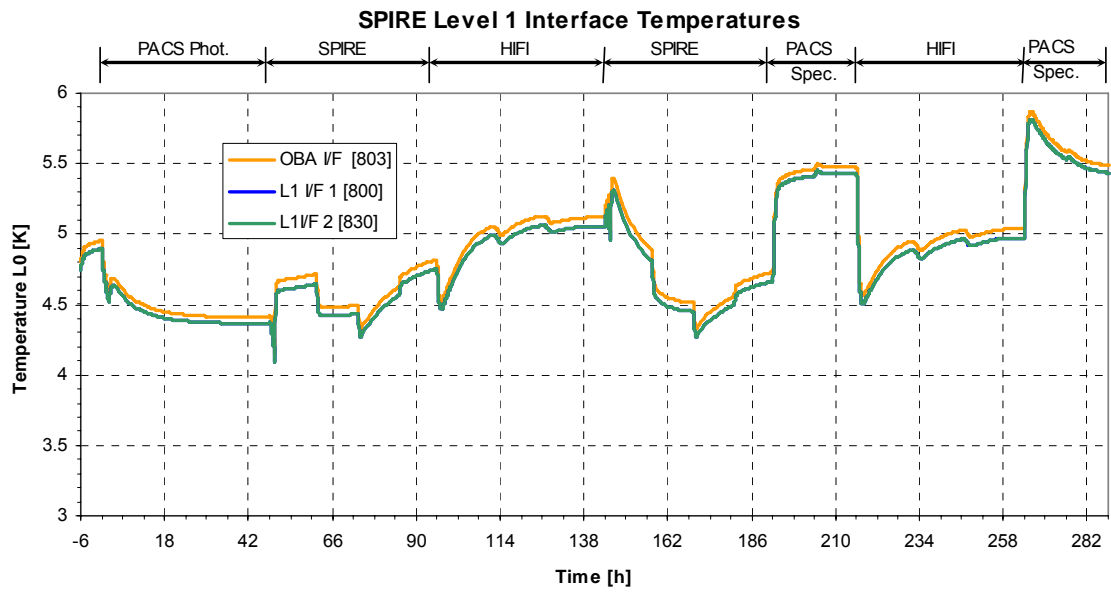

Figure 6.4-14: SPIRE L1 Interface Temperatures

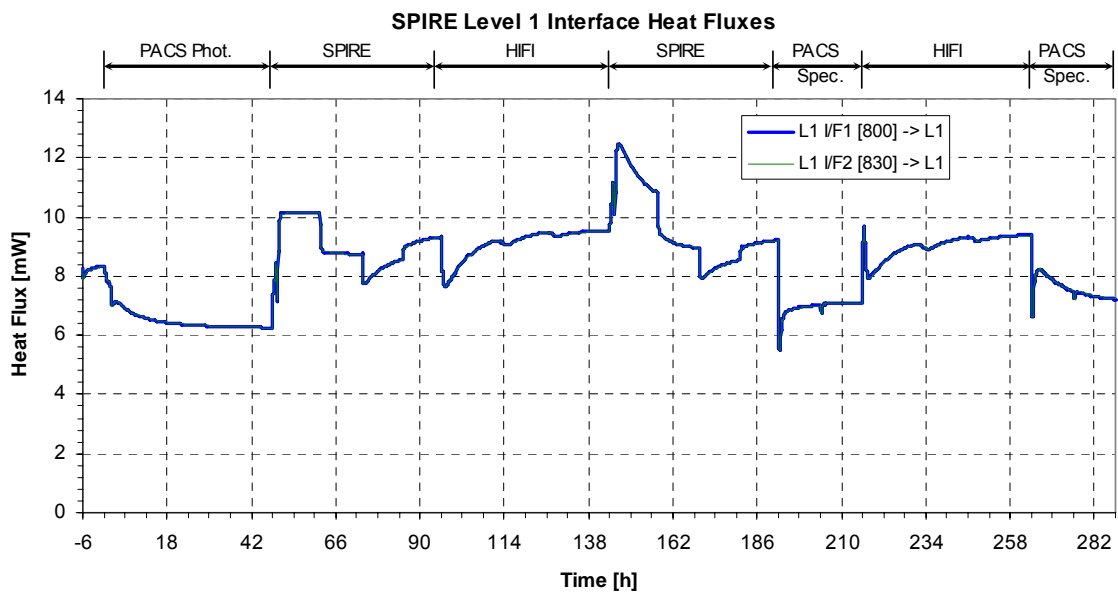

Figure 6.4-15: SPIRE L1 Interface Heat Fluxes

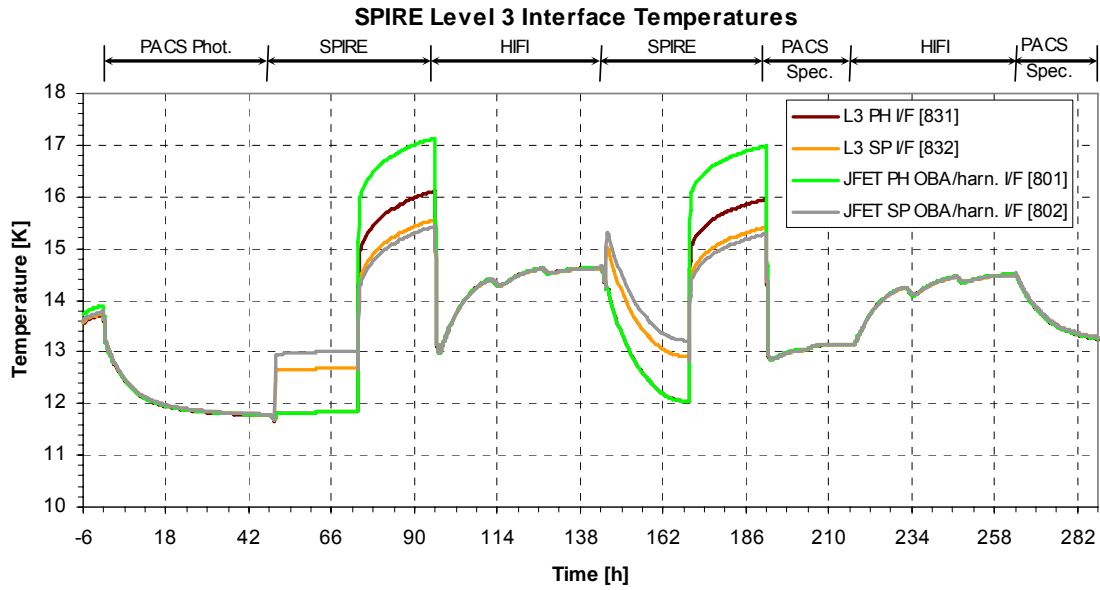

Figure 6.4-16: SPIRE L3 Interface Temperatures

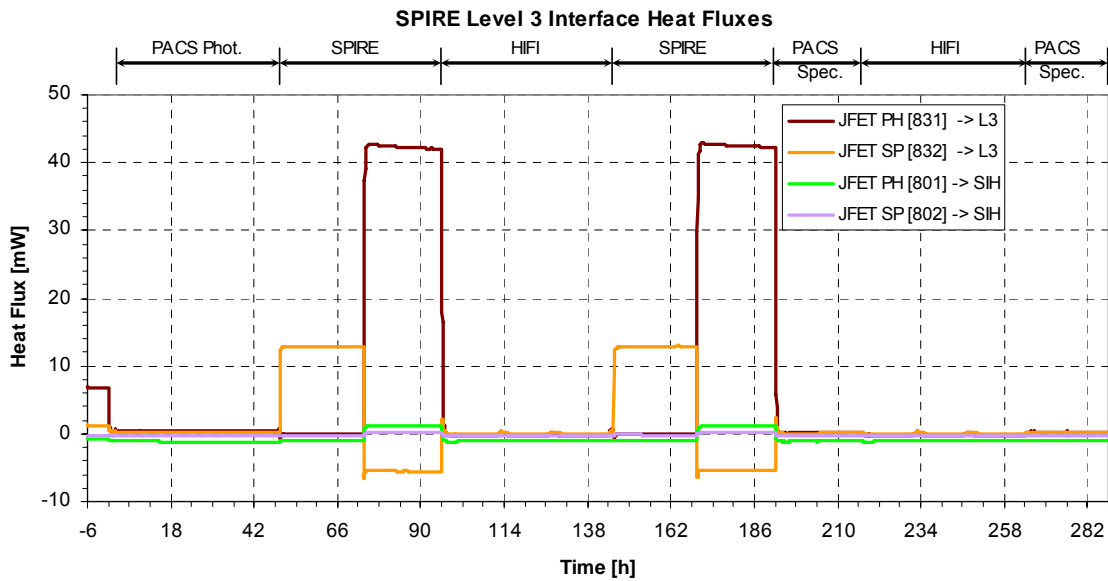

Figure 6.4-17: SPIRE L3 Interface Heat Fluxes

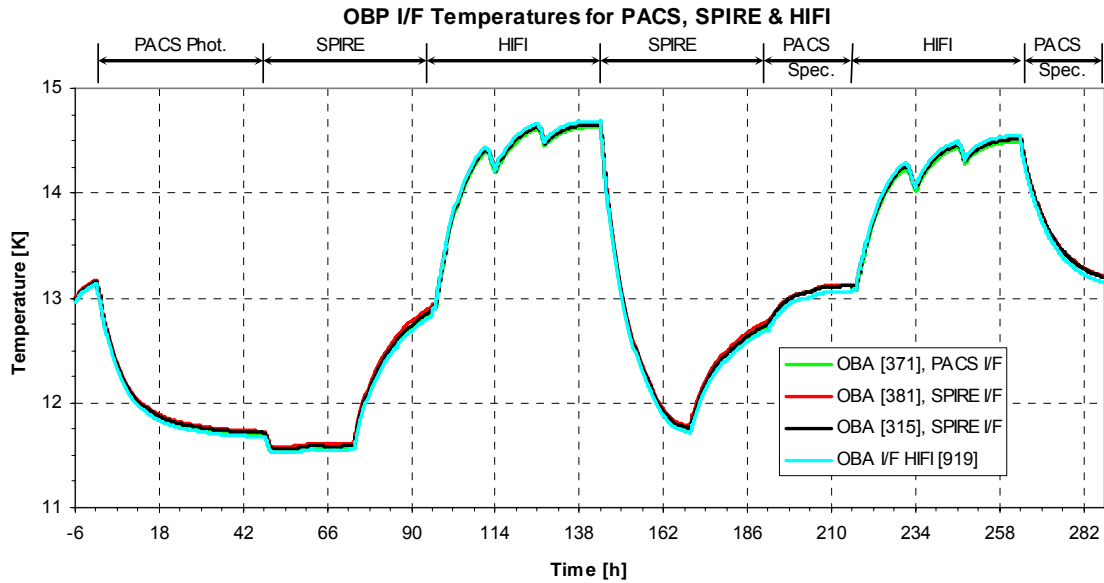

Figure 6.4-18: FPU L2 Interface Temperatures

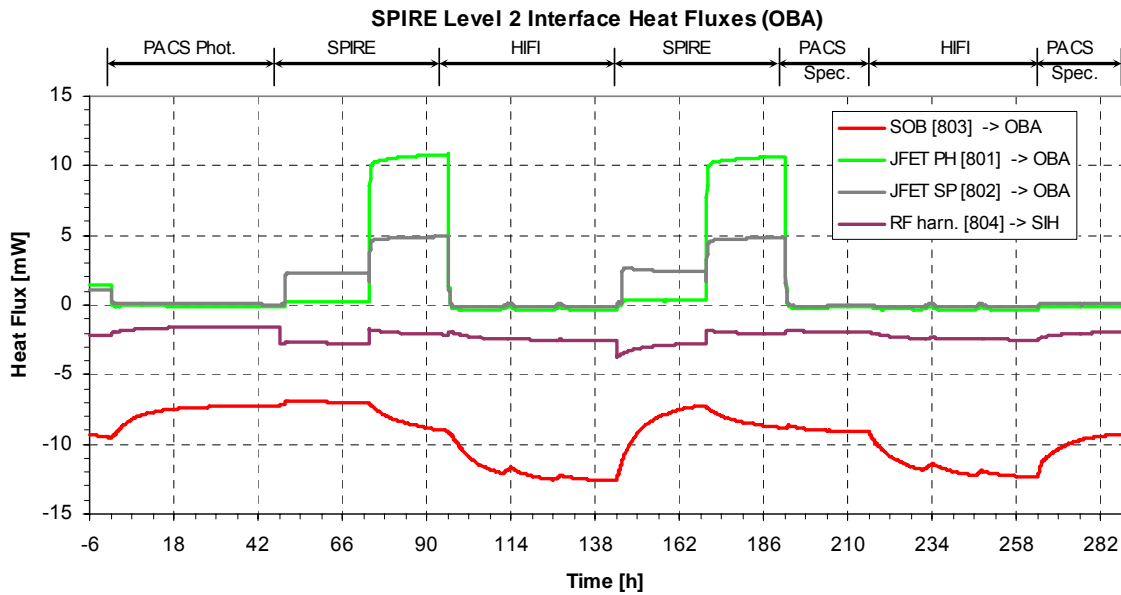

Figure 6.4-19: SPIRE L2 Interface Heat Fluxes

6.4.3 HIFI Interface Temperatures and Heat Flows

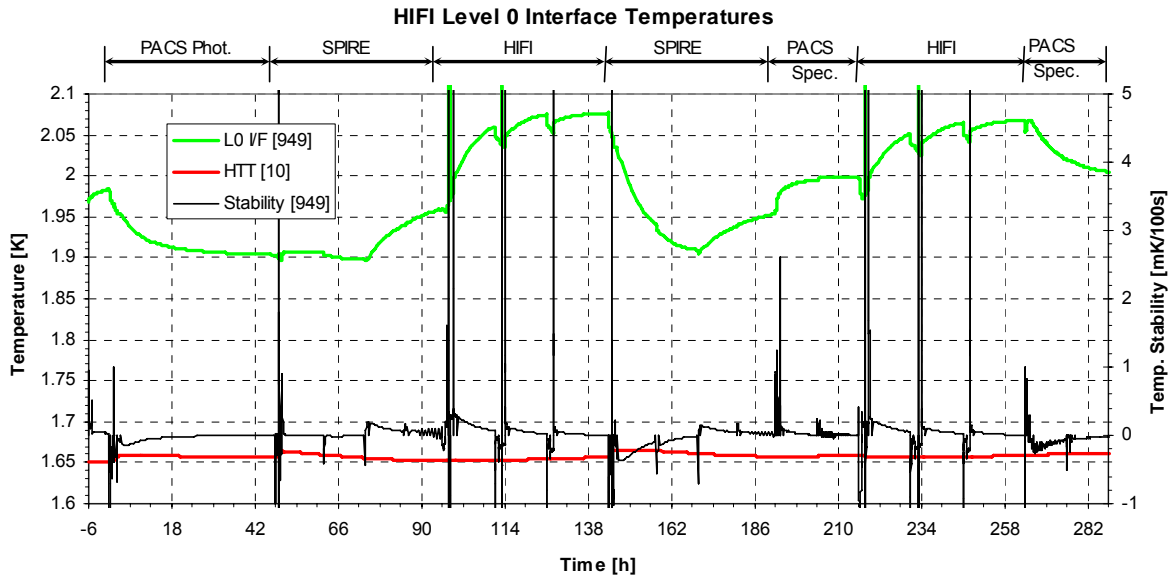

Figure 6.4-20: HIFI L0 Interface Temperature and Stability

Note that the temperature stability peaks of HIFI are caused by short heat peak phases due to dissipation switching.

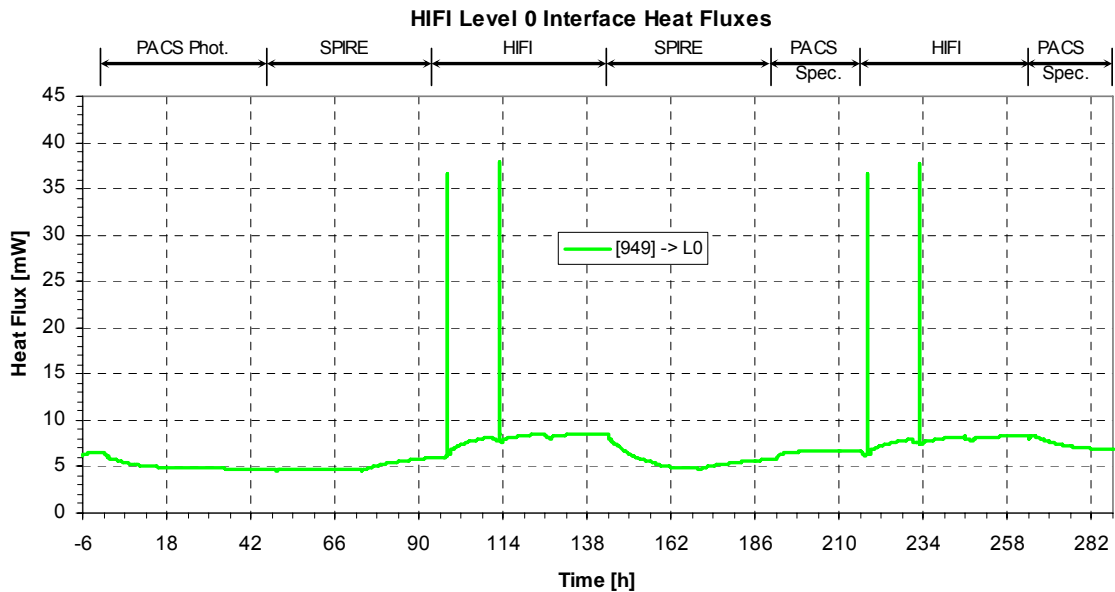

Figure 6.4-21: HIFI L0 Interface Heat Flow

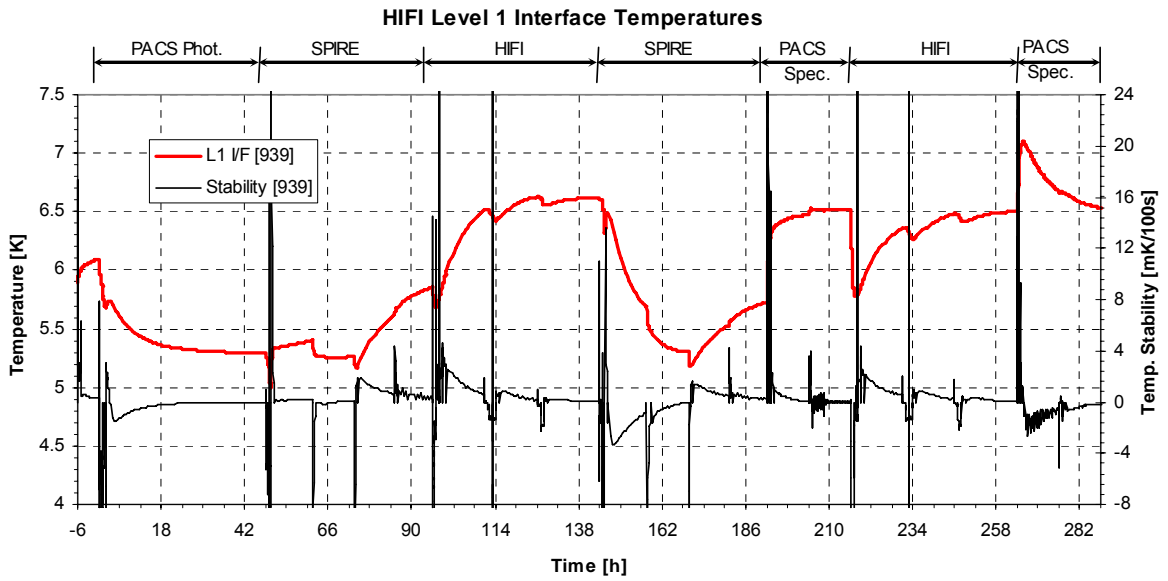

Figure 6.4-22: HIFI L1 Interface Temperature and Stability

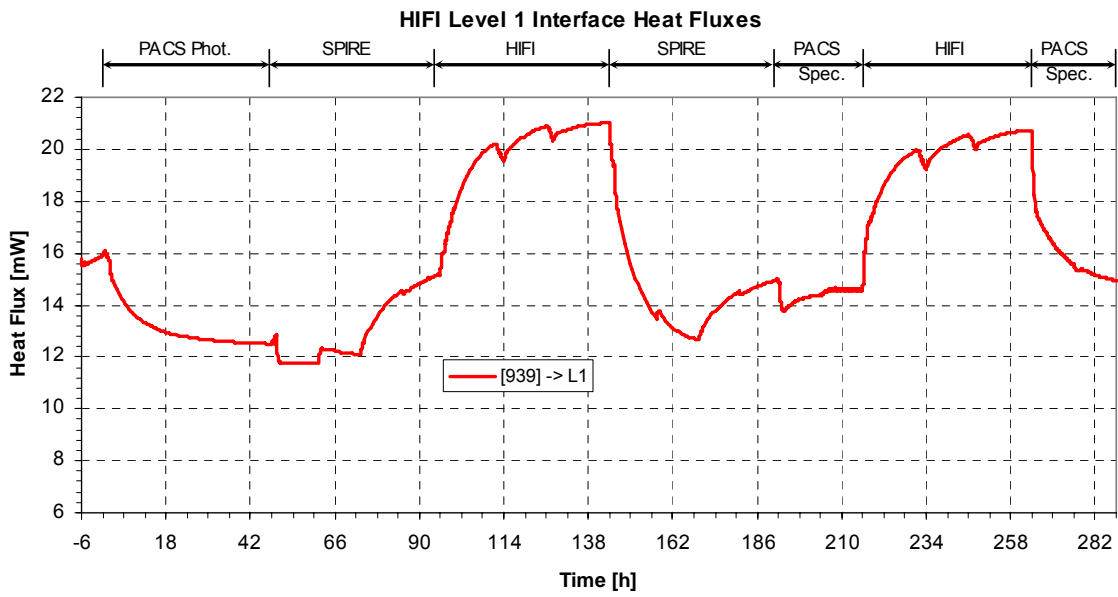

Figure 6.4-23: HIFI L1 Interface Heat Flow

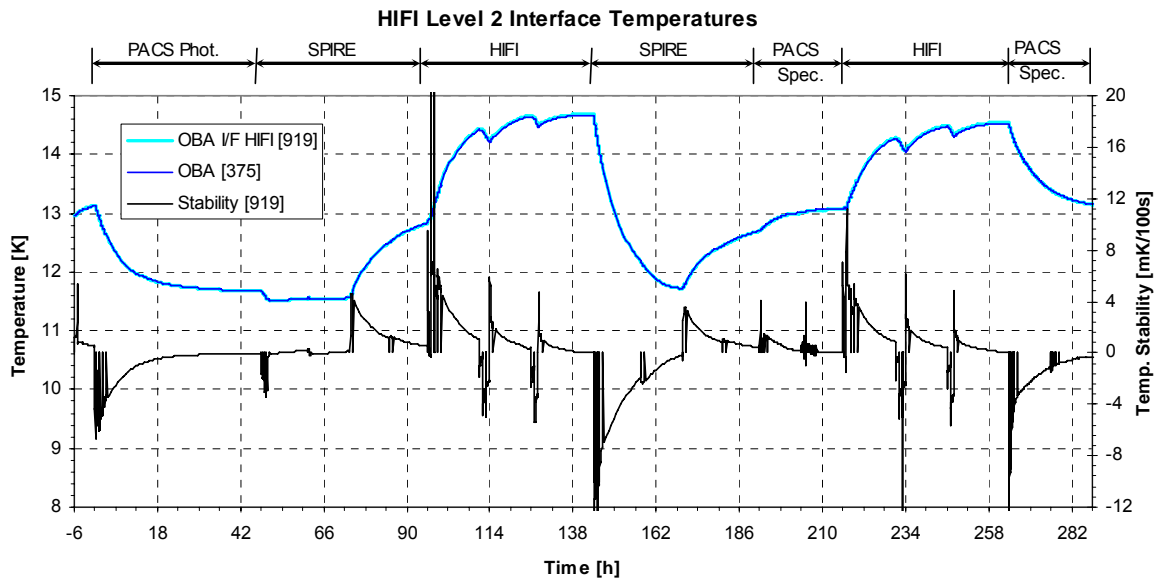

Figure 6.4-24: HIFI L2 Interface Temperature and Stability

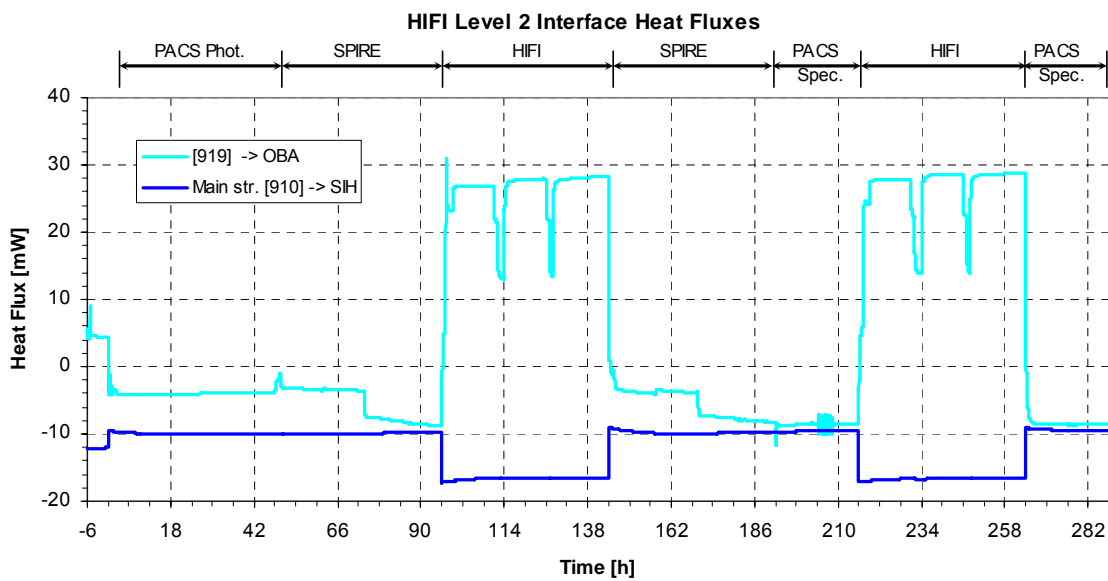

Figure 6.4-25: HIFI L2 Interface Heat Flow

6.4.4 Instrument Heat Load on HTT and He Mass Flow

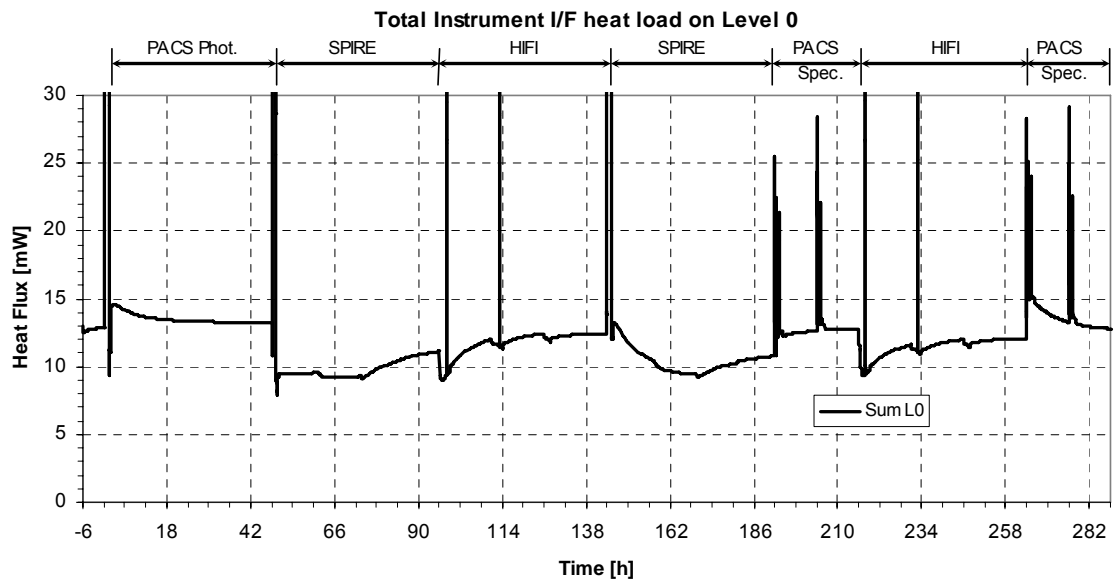
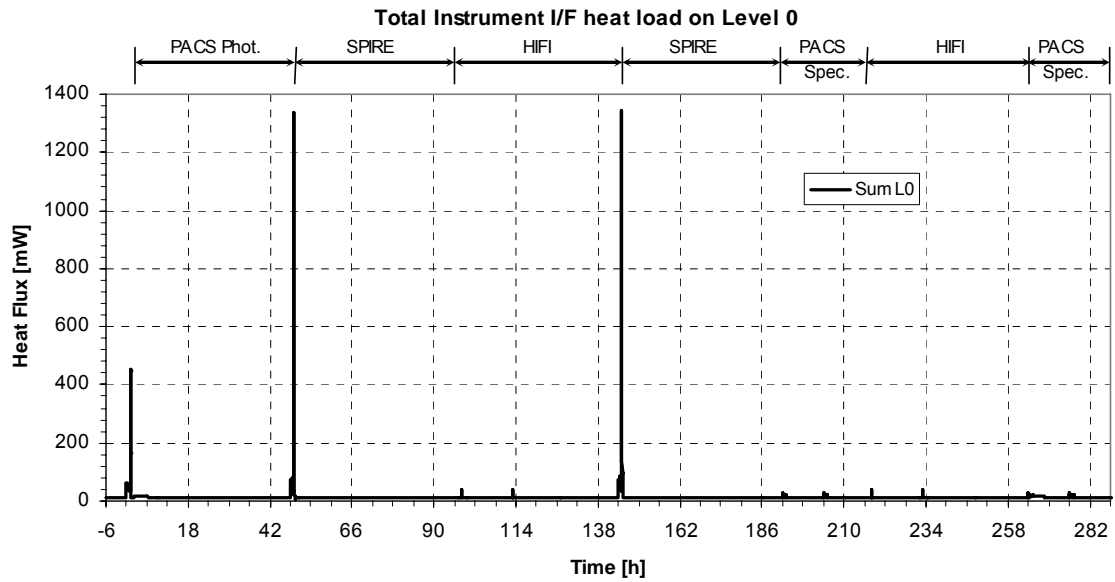

Figure 6.4-26: Total Instrument I/F Heat Load on HTT (different scales on Y-axis)

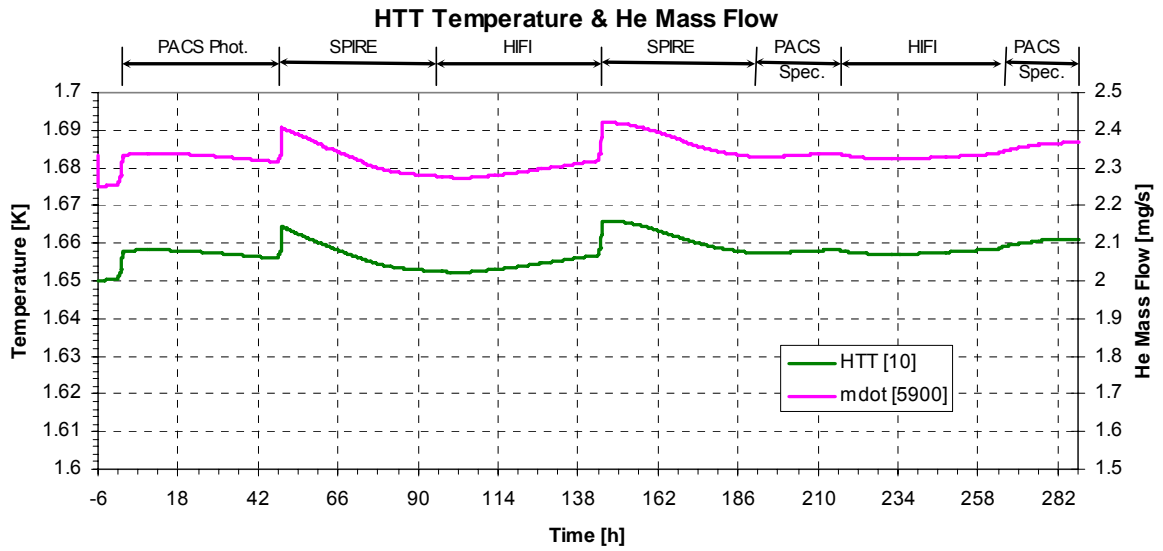

Figure 6.4-27: HTT Temperature and He Mass Flow Rate

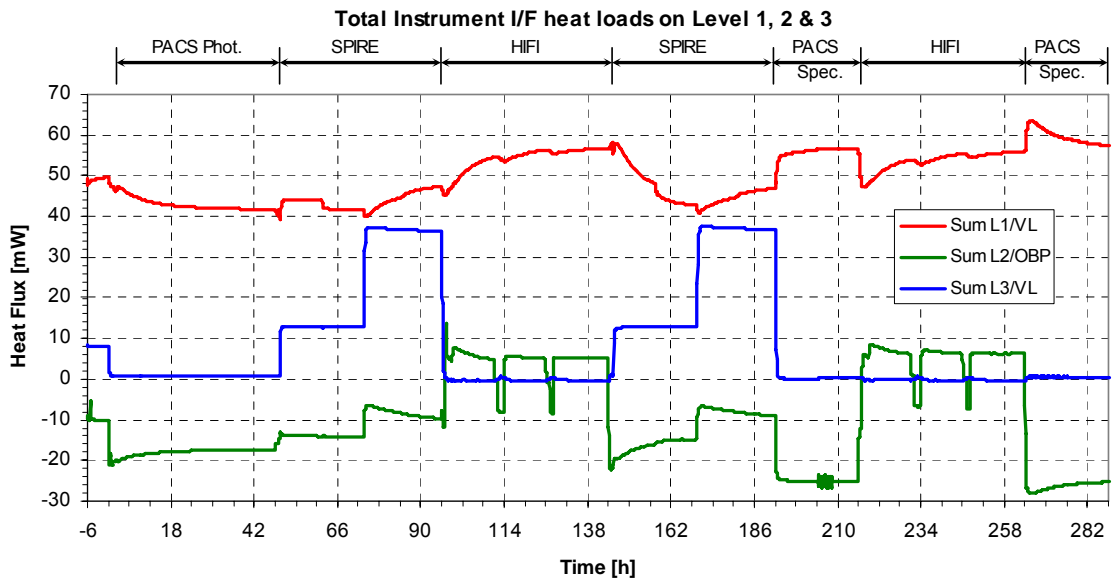

Figure 6.4-28: Total Instrument I/F Heat Load on L1, L2 and L3

6.4.5 Sensitivity Analysis

The following sensitivities have been performed:

- Hot Case with nearly empty HTT: hot case environment at L2 and 35 kg He in the tank (detailed results see sections 6.4.1 to 6.4.4)
- Cold Case with nearly empty HTT: cold case environment at L2 and 35 kg He in the tank
- Hot Case with nearly full HTT: hot case environment at L2 and 300 kg He in the tank

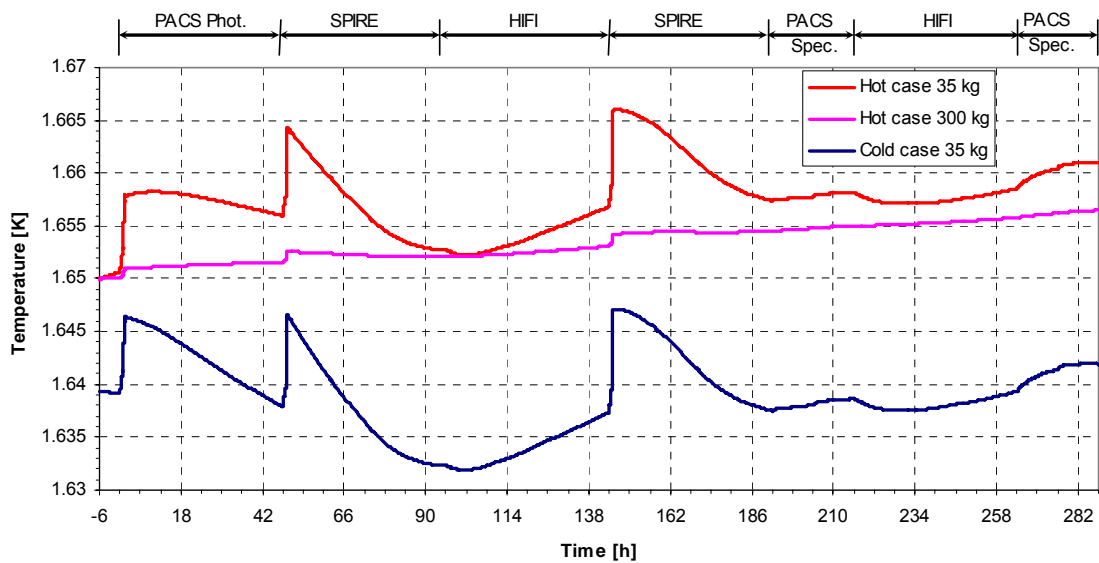

Figure 6.4-29: HTT Temperature for Different Conditions

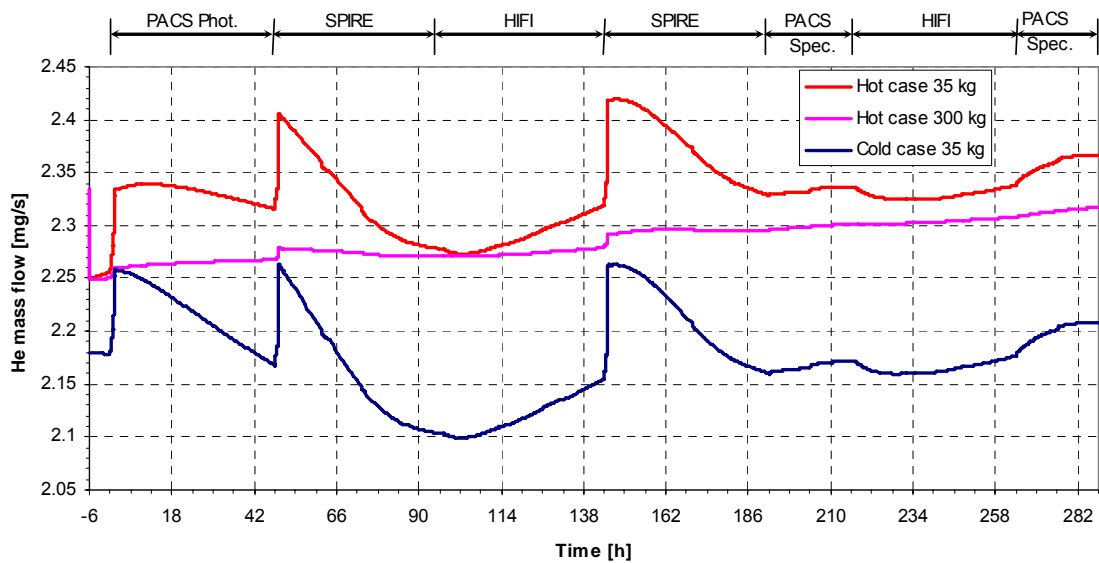

Figure 6.4-30: Helium Mass Flow for Different Conditions

In the following figures some representative temperatures curves are shown for the level 0, 1, 2 and 3 instrument interfaces.

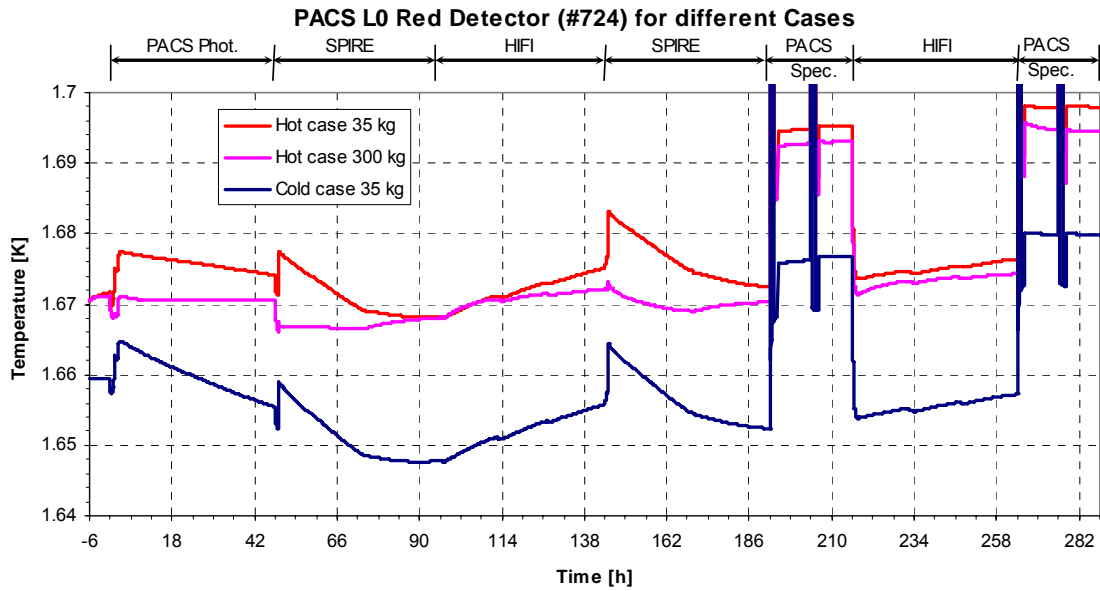

Figure 6.4-31: PACS L0 Temperature for Different Conditions

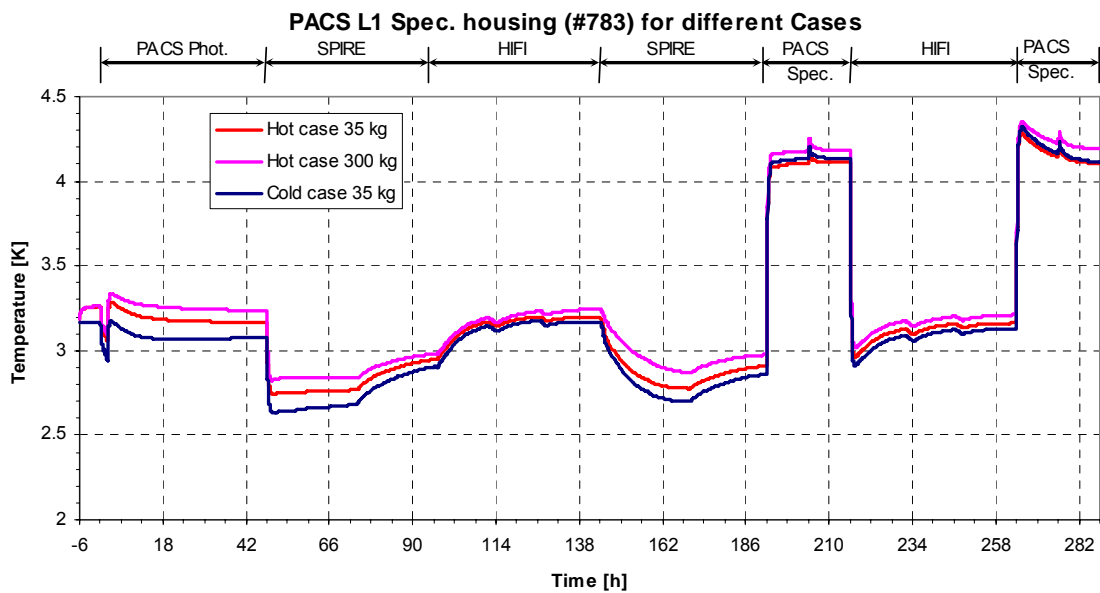

Figure 6.4-32: PACS L1 Temperature for Different Conditions

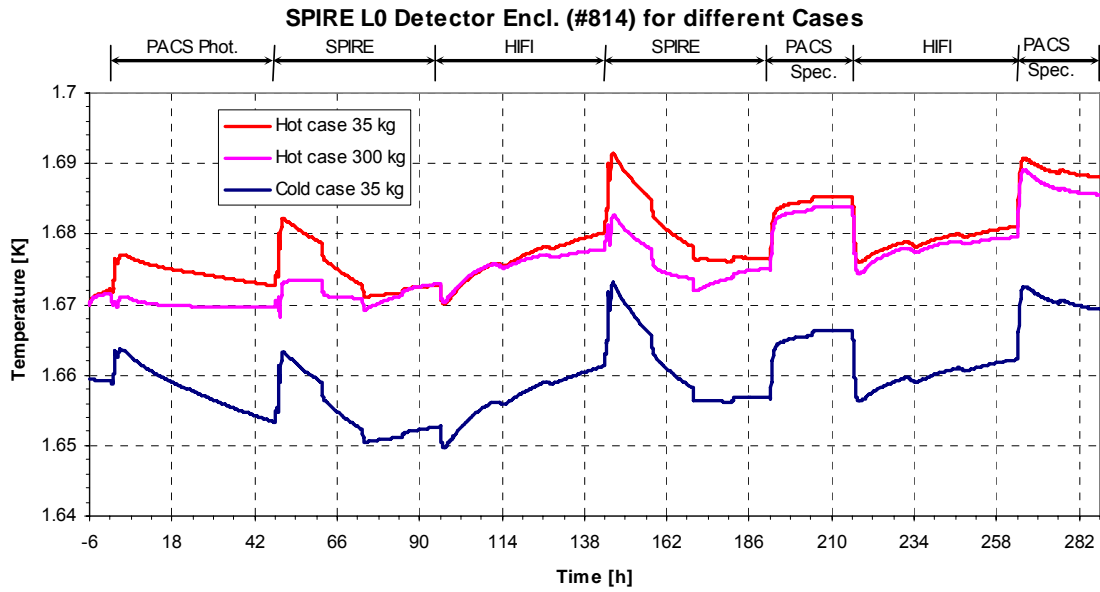

Figure 6.4-33: SPIRE L0 Temperature for Different Conditions

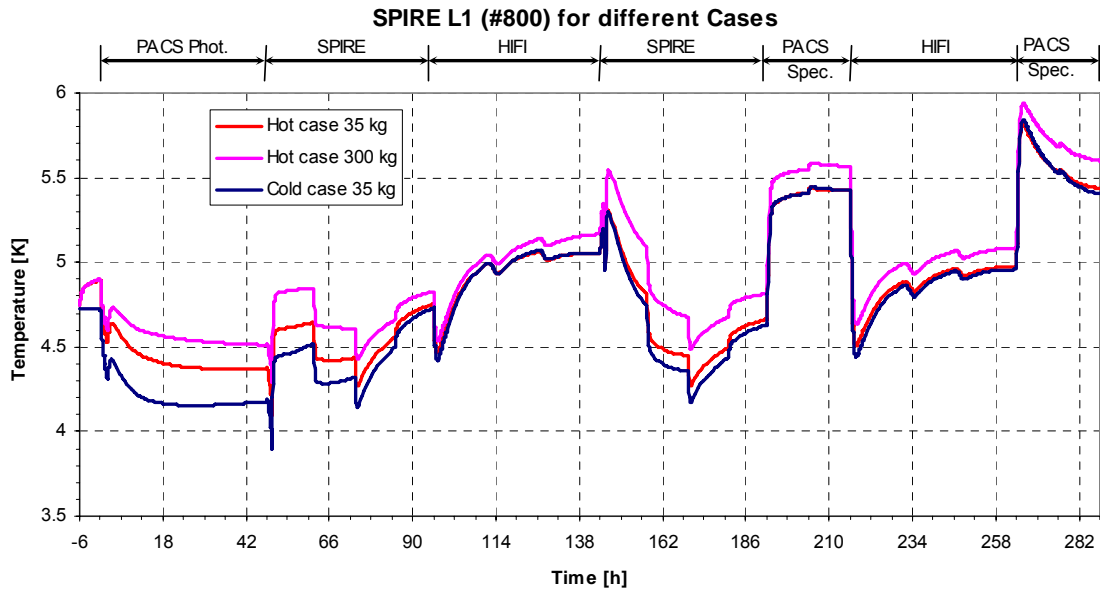

Figure 6.4-34: SPIRE L1 Temperature for Different Conditions

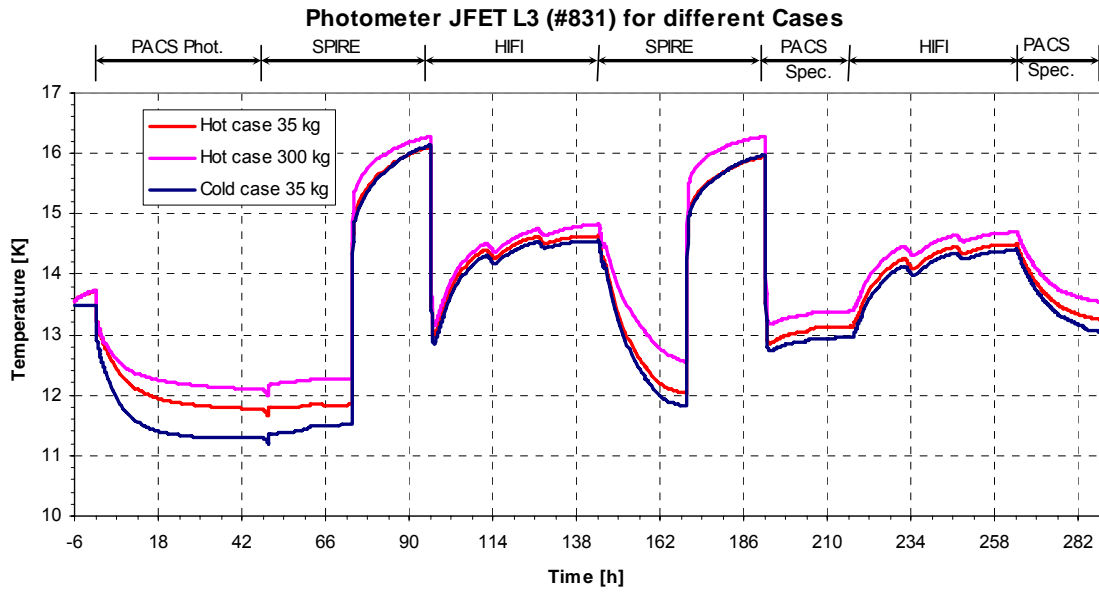

Figure 6.4-35: Photometer JFET L3 Temperature for Different Conditions

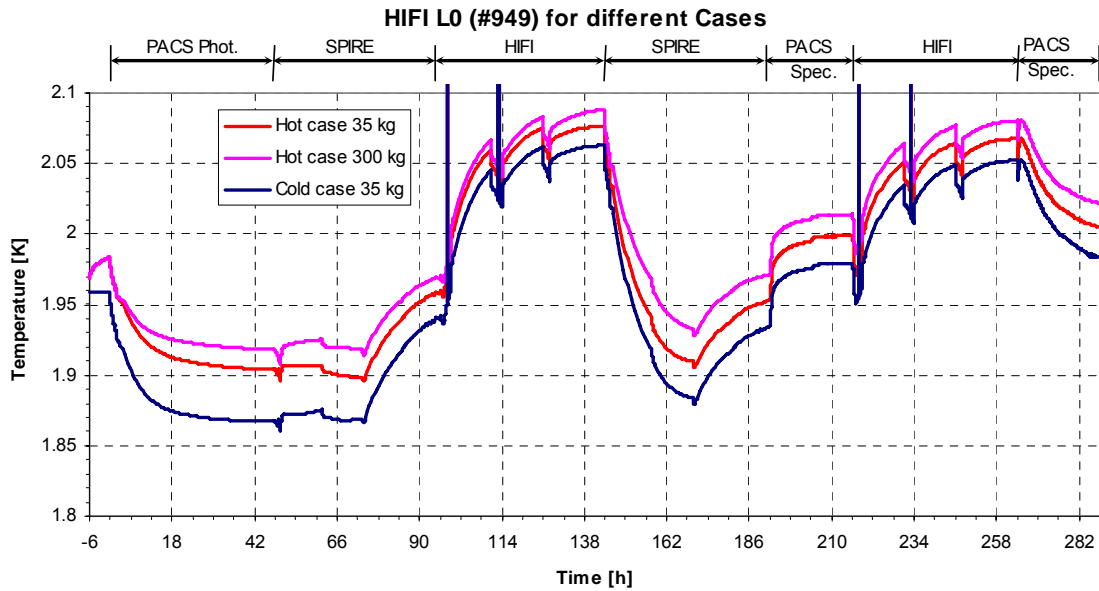

Figure 6.4-36: HIFI L0 Temperature for Different Conditions

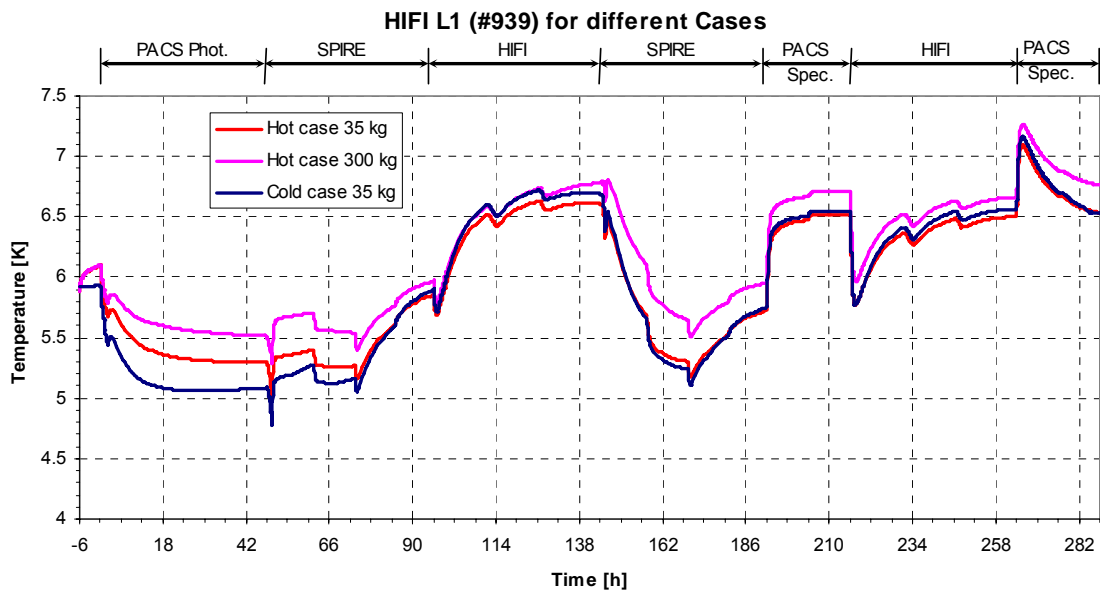

Figure 6.4-37: HIFI L1 Temperature for Different Conditions

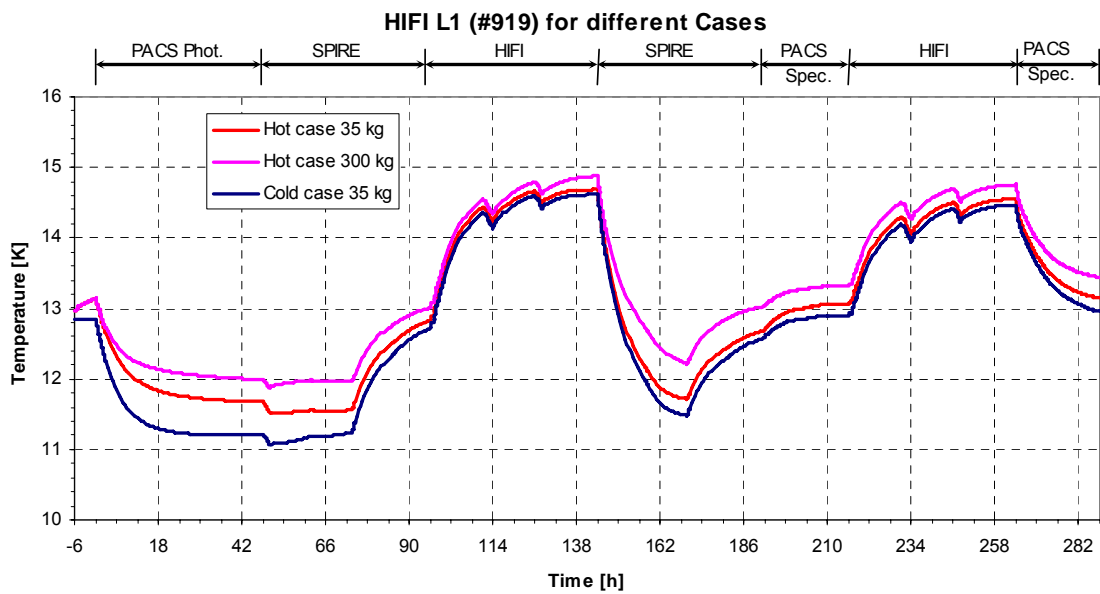

Figure 6.4-38: HIFI L2 Temperature for Different Conditions

6.5 Lifetime Performance

6.5.1 Lifetime Formula

Basically, the lifetime is defined by the total parasitic heat load into the HTT $\sum Q_{HTT}$ and the helium heat of vapourisation h_{vap} for the average environmental conditions at L2 (see Table 3.2-1), leading to an average He massflow $M_{He, avg}$.

Additional parameters determining the lifetime in detail are:

- The nominal initial helium mass m_0 is based on a filling level of 98 % and shall include a margin of 15%. (HERS-0530 [AD 06])
- The increased helium consumption m_{trans} during the in-orbit cooldown period t_{trans} (transfer orbit) is considered.
- The residual He gas $m_{residual}$ that cannot be used for vapour cooling at the end of the mission is included.
- A lifetime correction factor $t_{uncertainty}$ is applied reflecting parameter variations.
- DLCM in-orbit measurements for determination of the remaining helium mass are considered with a maximum lifetime loss of 0.36% [RD 19].
- The effect of the configuration changes introduced by ESA/ASPI (startracker attached to CVV, SPIRE harness overall shield, LOU radiator enlargement) on the lifetime is included in the TMM, but is compensated in the lifetime calculation by t_{others} .

Finally, the lifetime is calculated according to the following formula:

$$\text{Lifetime} = 0.9964 * ((m_0 - m_{trans} - m_{residual}) / M_{He, avg} + t_{trans} - t_{uncertainty} + t_{others})$$

with

m_0	nominal amount of He at lift off; $m_0 = 0.98/1.15 * \text{He density} * \text{HTT volume}$
m_{trans}	He consumption during in-orbit cool down
$m_{residual}$	residual He gas in HTT at EOL; $m_{residual} = 0.94 * \text{GHe density} * \text{HTT volume}$
$M_{He, avg}$	mass flow at L2 (at conditions described in section 3.1.1); $M_{He} = \sum Q_{HTT} / h_v$
t_{trans}	duration of transient cool down until HTT @ 1.65K
$t_{uncertainty}$	Lifetime correction due to RSS input variations
t_{others}	Lifetime compensation

6.5.2 Lifetime Calculation

According to the lifetime formula presented in section 6.5.1, the expected lifetime is calculated by thermal analysis as follows:

m_0	= 0.98 / 1.15 * 145.338 kg/m ³ * 2.367m ³ = 293.16 kg
m_{trans}	= 21.1 kg (compare to section 6.2)
$m_{residual}$	= 0.94 * 0.33 kg/m ³ * 2.367m ³ = 0.73 kg
$M_{He, avg}$	= 2.261 mg/s
t_{trans}	= 58 days (compare to section 6.2)
$t_{uncertainty}$	= -97 days (compare to section 6.3.2)
t_{others}	= +37 days

The lifetime compensation t_{others} is composed of following:

- Enlarged LOU radiator: - 7 days (radiator area increased by about 100 %)
- Startracker on CVV: - 14 days (additional 200 mW heat load to CVV)
- SPIRE overall shield: - 16 days (20 mm² additional stainless steel cross-section for CVV internal harness and 24 mm² additional manganin cross-section for CVV external harness)

Thus, the lifetime formula can be written:

$$\begin{aligned}
 \text{Lifetime [days]} &= \\
 &= 0.9964 * ((293.16 \text{ kg} - 21.1 \text{ kg} - 0.73 \text{ kg}) * 1E6 / (M_{He, avg} [\text{mg/s}] * 3600 * 24) + 58 \text{ days} + 37 \text{ days} \\
 &\quad - 97 \text{ days}) = \\
 &= 0.9964 * (3140.4 / M_{He} [\text{mg/s}] + 95 \text{ days} - 97 \text{ days}) = 1382 \text{ days} = \mathbf{3.79 \text{ years}}
 \end{aligned}$$

With this result the requirement of 3.5 years is fulfilled.

Taking into account all uncertainties (compare to section 6.3.2), the lifetime is predicted in a range of 4.05 years -97 days/+145 days.

Considering a “realistic” lifetime performance, i. e. by neglecting the 15% ESA margin and the lifetime compensation factor “ t_{others} ”, the predictions end up with 4.56 years -97 days/+145 days.

6.6 Instrument Interface Temperatures for IID-B Allocations

For verification of the instrument interface temperatures according to IID-B some extra calculations have been performed. They are based on hot orbit environmental conditions at L2, the HTT is fixed at its in-orbit target temperature of 1.65 K.

For analysis the following modes have been calculated:

- PACS nominal operation
- PACS cooler pump (peak) operation
- SPIRE nominal operation in Photometer mode (PH JFET operational)
- SPIRE nominal operation in Spectrometer mode (SP JFET operational)
- SPIRE cooler pump (peak) in Photometer mode (PH JFET operational), including L0 and L1 goals
- SPIRE cooler pump (peak) in Spectrometer mode (SP JFET operational), including L0 and L1 goals
- HIFI nominal operation

The dissipation of the LOU is considered with 7 W for all modes.

All runs stated above have been run with two different mass flows.

The calculation approach is that for each operational mode the corresponding interface heat loads given in Table 6.6-1 are allocated to the interface nodes of the relevant instrument model in the TMM. All other nodes of this instrument are set inactive to avoid thermal contact between the single interfaces and thus additional parasitic interface heat flows.

The given uncertainties are adopted from section 6.3.2.

The temperature limits required at the instrument interfaces are specified in the instrument interface control documents (IID-Bs) for PACS [AD 02], SPIRE [AD 03] and HIFI/LOU [AD 04] and are shown in section 3.1. An extract of the in-orbit operating requirements is also given in Table 6.6-1. These can be directly compared to the predicted temperatures, which have been calculated for two different fixed massflow rates: 2.3 mg/s following the in-orbit hot massflow of 2.335 mg/s, and 2.4 mg/s to show the sensitivity.

Compared to the issue 4 of this Thermal Report, the PACS L0 I/F heat loads have slightly increased by 0.2 mW for the Red and Blue Detector and the Cooler Pump, respectively, and by 0.1 mW for the cooler Evaporator. The L0 flexible copper links are now provided by PACS and therefore are part of the updated PACS TMM [RD 03]. The I/F nodes listed in Table 6.6-1 are thus located between PACS flexible links and ASSED rigid/open pods, on strap side. SPIRE has also provided an updated TMM [RD 04], the location of the L0 I/F nodes remains unchanged and is similar to PACS. The HIFI TMM is unchanged [RD 05] since the Thermal Report issue 4, the I/F node is located between flex link and FPU, on FPU side.

	Interface	I/F Requirement		Node	Analysis Results	
		Heat Load	Temperature		2.3 mg/s	2.4 mg/s ⁽²⁾
Level 0	PACS Red Detector	1.0 mW	1.6 K ... 1.75 K	724	1.683 K ± 0.06 K	1.683 K ± 0.06 K
	PACS Blue Detector	2.2 mW	1.6 K ... 2 K	723	1.724 K ± 0.06 K	1.724 K ± 0.06 K
	PACS Cooler Pump	2.2 mW	1.6 K ... 5 K	761	1.711 K ± 0.06 K	1.711 K ± 0.06 K
		500 (peak) mW	1.6 K ... 12.06 K ⁽⁵⁾		5.844 K ± 0.06 K	5.844 K ± 0.06 K
	PACS Cooler Evapor.	15.1 mW	1.6 K ... 1.85 K	762	1.725 K ± 0.06 K	1.725 K ± 0.06 K
	SPIRE Detector	4 mW	< 2 K	814	1.755 K ± 0.06 K	1.755 K ± 0.06 K
		1 mW (goal)	< 1.71 K (goal)		(1.678 K ± 0.06 K)	(1.678 K ± 0.06 K)
	SPIRE Cooler Pump	2 mW	< 2 K	815	1.700 K ± 0.06 K	1.700 K ± 0.06 K
		500 mW (peak)	< 10 K (peak)		5.753 K ± 0.06 K	5.753 K ± 0.06 K
	SPIRE Cooler Evap.	15 mW	< 1.85 K	816	1.729 K ± 0.06 K	1.729 K ± 0.06 K
15 mW (goal)		< 1.75 K (goal)	(1.729 K ± 0.06 K)		(1.729 K ± 0.06 K)	
	HIFI Detector	6.8 mW	< 2.1 K ⁽⁴⁾	949	1.993 K ± 0.06 K	1.993 K ± 0.06 K
Level 1	PACS FPU	30 mW	2 K ... 5 K	781	3.35 K ± 0.08 K	3.30 K ± 0.08 K
				782	4.00 K ± 0.08 K	3.91 K ± 0.08 K
				783	4.35 K ± 0.08 K	4.23 K ± 0.08 K
	SPIRE FPU	15 mW	< 5.5 K	800	4.77/4.53 K ± 0.15 K	4.51/4.31 K ± 0.15 K
		13 mW (goal)	< 3.7 K (goal)		(4.56/4.39 K ± 0.15 K) ⁽³⁾	(4.31/4.11 K ± 0.15 K) ⁽³⁾
	HIFI L1	15.5 mW	< 6.4 K ⁽⁴⁾	939	6.14 K ± 0.21 K	5.70 K ± 0.21 K
Level 2	OBP near PACS	0 mW	< 12 K	371	13.6 K ± 0.6 K	12.9 K ± 0.6 K
	OBP near SPIRE	0 mW	< 12 K	381	14.6/13.2 K ± 0.6 K ⁽³⁾	13.8/12.5 K ± 0.6 K ⁽³⁾
		0 mW (goal)	< 8K (goal)			
	Instr. Shield/SPIRE	0 mW	< 16 K	315	14.6/13.2 K ± 0.6 K ⁽³⁾	13.8/12.5 K ± 0.6 K ⁽³⁾
	HIFI FPU	22 mW	< 20 K	919	14.4 K ± 0.6 K	13.6 K ± 0.6 K
Level 3	SPIRE PM-JFET	56.64 mW ⁽⁶⁾	< 15.6 K ⁽⁵⁾	831	18.8 K ± 0.5 K	17.9 K ± 0.5 K
	SPIRE SM-JFET	25 mW	< 15 K	832	15.3 K ± 0.5 K	14.5 K ± 0.5 K
LOU	LOU (HIFI)	7000 mW	90 K ... 150 K	4201	(127/130) K ⁽¹⁾ +3/-6 K	

⁽¹⁾ cold/hot case environment at L2

⁽²⁾ sensitivity analysis

⁽³⁾ Photometer/Spectrometer mode temperatures

⁽⁴⁾ value acc. RFD [AD 11]; L0 was 2.0 K, L1 was 6.0 K before

⁽⁵⁾ value acc. RFD [AD 14]; PACS L0 was 10 K, PM JFET was 15 K before

⁽⁶⁾ value acc. RFW [AD 15]; was 50 mW before

Table 6.6-1: Specified versus calculated instrument interface temperatures for IID-B allocations

The change of interface temperatures compared to CDR /issue 4 status is mainly a consequence of the correlation activities performed in the frame of the two STM test campaigns [RD 45] [RD 46] [RD 48] [RD 49]. In particular, the LOU now is about 6 K colder due to modelling the LOU harness also in the GMM (see section 4.8), which helps radiating some parasitic heat.

The instrument interface transient temperatures along a typical timeline are shown in detail in section 6.4 together with their predicted interface heat flows.

To determine which massflow would be necessary to meet the requirements (L2 and L3), two more data sets have been generated, using massflows of 2.65 mg/s resp. 2.80 mg/s. The results are shown in the table below. A first idea of realising such high massflows is to use DLCM heating pulses.

	Interface	I/F Requirement		Node	Analysis Results	
		Heat Load	Temperature		2.65 mg/s	2.8 mg/s ⁽²⁾
Level 0	PACS Red Detector	1.0 mW	1.6 K ... 1.75 K	724	1.683 K ± 0.06 K	1.683 K ± 0.06 K
	PACS Blue Detector	2.2 mW	1.6 K ... 2 K	723	1.724 K ± 0.06 K	1.724 K ± 0.06 K
	PACS Cooler Pump	2.2 mW	1.6 K ... 5 K	761	1.711 K ± 0.06 K	1.711 K ± 0.06 K
		500 (peak) mW	1.6 K ... 12.06 K ⁽⁵⁾		5.844 K ± 0.06 K	5.844 K ± 0.06 K
	PACS Cooler Evapor.	15.1 mW	1.6 K ... 1.85 K	762	1.725 K ± 0.06 K	1.725 K ± 0.06 K
	SPIRE Detector	4 mW	< 2 K	814	1.755 K ± 0.06 K	1.755 K ± 0.06 K
		1 mW (goal)	< 1.71 K (goal)		(1.678 K ± 0.06 K)	(1.678 K ± 0.06 K)
	SPIRE Cooler Pump	2 mW	< 2 K	815	1.700 K ± 0.06 K	1.700 K ± 0.06 K
		500 mW (peak)	< 10 K (peak)		5.753 K ± 0.06 K	5.753 K ± 0.06 K
	SPIRE Cooler Evap.	15 mW	< 1.85 K	816	1.729 K ± 0.06 K	1.729 K ± 0.06 K
15 mW (goal)		< 1.75 K (goal)	(1.729 K ± 0.06 K)		(1.729 K ± 0.06 K)	
	HIFI Detector	6.8 mW	< 2.1 K ⁽⁴⁾	949	1.993 K ± 0.06 K	1.993 K ± 0.06 K
Level 1	PACS FPU	30 mW	2 K ... 5 K	781	3.209K ± 0.08 K	3.164K ± 0.08 K
				782	3.720K ± 0.08 K	3.626K ± 0.08 K
				783	3.969K ± 0.08 K	3.844K ± 0.08 K
	SPIRE FPU	15 mW	< 5.5 K	800	4.03/3.91 K ± 0.15 K	3.83/3.74K ± 0.15 K
		13 mW (goal)	< 3.7 K (goal)		(3.85/3.73K ± 0.15 K) ⁽³⁾	(3.66/3.57K ± 0.15 K) ⁽³⁾
	HIFI L1	15.5 mW	< 6.4 K ⁽⁴⁾	939	4.88K ± 0.21 K	4.53K ± 0.21 K
Level 2	OBP near PACS	0 mW	< 12 K	371	10.86 K ± 0.6 K	10.04 K ± 0.6 K
	OBP near SPIRE	0 mW	< 12 K	381	11.93/10.83 K ± 0.6 K	10.96/9.98 K ± 0.6 K
		0 mW (goal)	< 8K (goal)		⁽³⁾	⁽³⁾
	Instr. Shield/SPIRE	0 mW	< 16 K	315	11.88/10.8 K ± 0.6 K ⁽³⁾	10.92/9.95 K ± 0.6 K ⁽³⁾
	HIFI FPU	22 mW	< 20 K	919	11.81 ± 0.6 K	10.9 K ± 0.6 K
Level 3	SPIRE PM-JFET	56.64 mW ⁽⁶⁾	< 15.6 K ⁽⁵⁾	831	15.86 K ± 0.5 K	14.79 K ± 0.5 K
	SPIRE SM-JFET	25 mW	< 15 K	832	12.78K ± 0.5 K	11.87K ± 0.5 K
LOU	LOU (HIFI)	7000 mW	90 K ... 150 K	4201	(127/130) K ⁽¹⁾ +3/-6 K	

Table 6.6-2: Specified versus calculated instrument interface temperatures for IID-B allocations with increased massflow

As one can see, 2.65 mg/s is needed for PACS, 2.8 mg/s for SPIRE. It is obvious that with such high massflows the lifetime requirement (as it is defined now) would be violated. RFDs related to this issue have been raised and distributed to the instruments [RD 52] [RD 53], the final decision is pending.

Important: Note that the technical feasibility, impacts on operations and detailed approach to artificially increase the mass flow rate to values of 2.65mg/s and 2.8mg/s is not proven!

7 Summary and Conclusions

The status of the H-EPLM Thermal Model after the two STM test campaigns is described in detail and the corresponding analysis results are reported.

Calculation of the contractual lifetime using the instrument TMMs according to IID-B conditions [AD 12] leads to 3.79 years including uncertainties, which is compliant to the requirement of 3.5 years, with significant margin. Considering a "realistic" lifetime performance (neglecting 15% ESA margin and lifetime compensation factors "t_others") the predictions end up with 4.29 years including uncertainties.

Concerning the instrument interface temperature requirements for L0, L1, L2 and L3, the requirements for nominal massflow are met with the following exceptions: PACS Level 2, SPIRE Level 2 and Level 3 (see Table 6.6-1). Referring to this ASED has raised two RFDs [RD 52] [RD 53]. The results of this analysis are based on hot case, i.e. worst case conditions. Supplementary analyses with artificial mass flow increase have been performed in order to meet all instrument requirements (at the expense of lifetime). **Important:** Note that the technical feasibility, impacts on operations and detailed approach to artificially increase the mass flow rate to values of 2.65mg/s and 2.8mg/s is not proven!

Transient analyses using an instrument power timeline have been conducted for hot and cold case environment at L2 orbit as well as for a nearly full HTT and a nearly empty HTT. Evaluation of instrument timeline results show that the HIFI temperature stability goals are met.

8 ANNEX 1: Nodal Temperature Listing

Node	LABEL	Orbit hot T [K]	Orbit cold T [K]	Orbit avg T [K]	Orbit Safe T [K]	Ground T [K]
HERSCHEL						
99998	INACTIVE_NODE	0	0	0	0	0
99999	DEEP SPACE	3	3	3	3	293
EPLM						
10	MAIN TANK HTT LHe	1.65	1.63893	1.65	1.595	1.8
13	MAIN TANK HTT wall upp	1.65003	1.63896	1.65003	1.59502	1.80024
20	AUXILIARY TANK HOT	19.67254	18.90152	19.31211	18.18328	54.65869
75	PACS L1 Photometer T242	2.69646	2.6803	2.6939	2.42659	6.08194
85	SPIRE L1 T248	4.74709	4.72522	4.74992	4.14929	11.89764
88	PH JFET L3 T251, T252	13.54958	13.48472	13.55475	11.44184	20.48005
89	SP JFET L3 T249, T250	13.5749	13.52974	13.59988	11.4494	20.4151
91	HIFI L0 pod-braid T228	1.86166	1.85159	1.86264	1.76128	2.36865
92	HIFI L0	1.96668	1.95658	1.96813	1.84201	2.65308
95	HIFI L1 T244	5.88626	5.93041	5.92928	5.28314	8.88234
111	MLI ON MAIN TANK LOW	3.53974	3.29923	3.42995	3.05951	58.99741
112	MLI ON MAIN TANK CYL	3.58976	3.34839	3.47972	3.10087	58.09178
113	MLI ON MAIN TANK UPP	3.62082	3.38071	3.51204	3.08587	52.40517
121	MLI ON AUX TANK LOW	22.08916	21.0822	21.61708	20.15358	70.9139
122	MLI ON AUX TANK UPP	21.38174	20.44625	20.94353	19.58076	68.04203
201	SF lo strut HTT end	1.65856	1.64684	1.65825	1.60235	1.89001
211	SF lo belt pZ	19.46827	18.70755	19.11265	17.999	54.26199
212	SF lo belt mY	19.49076	18.72987	19.13505	18.02113	54.30522
213	SF lo belt mZ	19.46954	18.7093	19.11414	18.00119	54.24549
214	SF lo belt pY	19.45599	18.69582	19.10063	17.98782	54.21781
221	SF lo corner pZmY	19.47089	18.71022	19.11529	18.00172	54.26079
222	SF lo corner mZmY	19.49502	18.7343	19.13939	18.02572	54.29935
223	SF lo corner mZpY	19.46184	18.70196	19.10661	17.99421	54.21286
224	SF lo corner pZpY	19.45299	18.693	19.09771	17.98516	54.20109
231	SF up strut HTT end	1.65435	1.64319	1.65432	1.59849	1.81356
241	SF up belt pZ	13.60157	13.43854	13.54592	12.01766	23.61747
242	SF up belt mY	13.73337	13.55884	13.67195	12.13988	24.7019
243	SF up belt mZ	13.69483	13.52321	13.63491	12.09762	24.53731
244	SF up belt pY	13.62813	13.46348	13.57169	12.03142	23.74654
251	SF up corner pZmY	13.59889	13.43613	13.54338	12.01812	23.58293
252	SF up corner mZmY	13.7677	13.59057	13.70498	12.17102	24.89088
253	SF up corner mZpY	13.67665	13.50681	13.61764	12.07937	24.34753
254	SF up corner pZpY	13.6167	13.45365	13.56106	12.02007	23.52845
271	Susp. Straps pZmY low	28.77851	27.83065	28.33509	26.95146	73.25015
272	Susp. Straps pZmY low	28.86708	27.91328	28.42073	27.02527	73.90186
273	Susp. Straps mZmY low	28.91438	27.9569	28.46616	27.06595	74.32577
274	Susp. Straps mZmY low	28.95041	27.99182	28.50167	27.09909	74.43873
275	Susp. Straps mZpY low	28.89095	27.93641	28.44422	27.04899	73.88647
276	Susp. Straps mZpY low	28.7802	27.83245	28.3368	26.9548	73.16627
277	Susp. Straps pZpY low	28.65681	27.71727	28.21757	26.84981	72.30343
278	Susp. Straps pZpY low	28.64788	27.70903	28.20891	26.84159	72.28262
281	Susp. Straps pZmY upp	27.56902	26.78622	27.20657	25.86748	61.74958
282	Susp. Straps pZmY upp	28.63304	27.81269	28.25228	26.71867	65.67638
283	Susp. Straps mZmY upp	31.0657	30.08134	30.60411	29.01253	77.96509
284	Susp. Straps mZmY upp	32.07208	31.02715	31.58045	29.89505	83.27017
285	Susp. Straps mZpY upp	30.64077	29.69057	30.19629	28.57112	76.99191
286	Susp. Straps mZpY upp	26.49236	25.71686	26.13368	24.77412	61.83699

Node	LABEL	Orbit hot T [K]	Orbit cold T [K]	Orbit avg T [K]	Orbit Safe T [K]	Ground T [K]
287	Susp. Straps pZpY upp	27.88597	27.14844	27.54558	25.94322	57.27391
288	Susp. Straps pZpY upp	27.66087	26.92894	27.32325	25.82614	56.59611
291	S. Str. pZmY upp har.IF	23.35445	22.73814	23.07437	21.69249	47.78119
292	S. Str. pZmY upp har.IF	25.77469	25.06832	25.45077	23.6102	56.67095
293	S. Str. mZmY upp har.IF	29.77373	28.81926	29.32669	27.63056	69.41489
294	S. Str. mZmY upp har.IF	31.0792	30.06035	30.6005	28.81075	74.80078
295	S. Str. mZpY upp har.IF	29.04773	28.15567	28.63245	26.83877	68.30689
296	S. Str. mZpY upp har.IF	19.43736	18.9338	19.21238	17.79039	43.04791
297	S. Str. pZpY upp har.IF	25.27942	24.67721	25.00557	22.78067	45.93338
298	S. Str. pZpY upp har.IF	24.92901	24.32732	24.65552	22.69524	45.20641
310	Instr. Shield Cyl.	12.97142	12.8604	12.94212	11.40125	19.87428
311	Instr. Shield Top	12.97373	12.86237	12.94426	11.40322	19.94707
315	Instr. Shield Baffle	12.97423	12.86276	12.9447	11.40359	19.97551
371	Opt. Bench +Z	12.95413	12.84506	12.92579	11.38503	19.20215
372	Opt. Bench +Z -Y	12.70418	12.61664	12.6865	11.20448	17.10833
373	Opt. Bench +Z mid	12.93658	12.82827	12.90856	11.36833	19.36208
374	Opt. Bench +Z +Y	12.95618	12.84701	12.92779	11.3873	19.22065
375	Opt. Bench -Y	12.9538	12.84314	12.92444	11.36925	20.07968
376	Opt. Bench centre	12.95425	12.84263	12.92443	11.36826	20.17923
377	Opt. Bench +Y	13.01309	12.89902	12.98235	11.43354	20.09178
378	Opt. Bench -Z -Y	13.11088	12.98994	13.0766	11.5231	20.8712
379	Opt. Bench -Z mid	12.99994	12.88633	12.9694	11.41584	20.3308
380	Opt. Bench -Z +Y	13.02628	12.91137	12.99514	11.44573	20.16474
381	Opt. Bench -Z	12.99367	12.88086	12.96363	11.41287	20.23305
400	V102	1.68884	1.67174	1.68585	1.62191	2.83561
401	V103	1.65946	1.64766	1.6591	1.60385	2.85405
402	V104	1.67615	1.66128	1.67429	1.61425	1.82986
403	V106	1.65904	1.64731	1.65871	1.60359	2.33614
404	SV123	2.18158	2.12537	2.15905	2.04544	6.75102
405	V701	19.46115	18.70056	19.10559	17.99212	54.2534
406	V702	19.48276	18.72238	19.12729	18.01412	54.28745
407	V105	19.45	18.6905	19.09495	17.9831	54.19106
408	SV723	19.43745	18.67778	19.08233	17.97024	54.18232
411	Tubing HOT-V701 supp 13	2.55386	2.43023	2.49979	2.29036	20.99631
412	Tubing HOT-V701 supp 12	4.05113	3.75881	3.91649	3.47075	32.94221
413	Tubing HOT-V701 supp 11	8.32859	7.80829	8.0886	7.3093	41.45417
414	Tubing HOT-V701 supp 27	16.24154	15.53194	15.91046	14.86776	51.01814
415	Tubing HOT-V701 supp 09	16.39081	15.65479	16.04758	14.96432	51.81705
416	Tubing HOT-V701 supp 01	17.51521	16.76433	17.16474	16.06168	52.96734
417	Tubing HOT-V701 LSFw str	19.67213	18.90114	19.31171	18.18292	54.65444
421	Tubing HOT-V105 supp 12	11.59927	11.32528	11.49148	10.90051	29.66362
422	Tubing HOT-V105 supp 11	4.81124	4.59324	4.72115	4.30731	31.09887
423	Tubing HOT-V105 supp 10	3.61543	3.38898	3.51403	3.15063	32.6217
424	Tubing HOT-V105 supp 07	8.82455	8.33573	8.59853	7.86781	41.32419
431	Tubing SV123-L1 supp 75	9.65274	9.11709	9.40335	8.58021	41.75031
432	Tubing SV123-L1 supp 18	6.31927	5.94131	6.14439	5.55063	25.52964
433	Tubing V103-L1 @ V103	5.0297	4.74244	4.89728	4.44352	20.19456
434	Tubing V103-L1 supp 14	4.35535	4.06854	4.22412	3.77237	1.88426
435	Tubing V103-L1 supp 15	3.02451	2.84834	2.9462	2.65243	1.8755
440	Filling port outer end	66.20152	63.15423	64.76343	59.519	292.00908
441	Filling port middle	65.1285	62.15003	63.7232	58.6021	277.49505
442	Filling port middle	63.12859	60.27515	61.78232	56.885	257.4894
443	Filling port Sline I/F	59.78827	57.13621	58.53885	54.00276	235.65885
444	Filling port Fline I/F	59.58705	56.94655	58.34309	53.82639	233.1105
445	Filling port inner end	59.58705	56.94655	58.34309	53.82639	233.1105

Node	LABEL	Orbit hot T [K]	Orbit cold T [K]	Orbit avg T [K]	Orbit Safe T [K]	Ground T [K]
451	Safety line @ FP IF	55.66363	53.26651	54.53473	50.46048	209.22798
452	Safety line	51.3375	49.19918	50.33087	46.73242	186.5037
453	Safety line	46.70303	44.83054	45.82191	42.72799	164.42238
454	Safety line	41.61076	40.02143	40.86331	38.32014	141.73067
455	Safety line @ strap IF	35.80565	34.5307	35.20667	33.29554	118.30151
456	Safety line	31.52251	30.36073	30.97694	29.23201	105.07182
457	Safety line support 34	26.43627	25.38682	25.9439	24.36291	91.04684
458	Safety line	21.86378	20.96379	21.44174	20.08346	76.35784
459	Safety line support 20	15.56791	14.8595	15.2363	14.16223	58.23818
461	Tubing SV123 - HTT	2.67424	2.57436	2.63046	2.45507	1.82977
462	Tubing HTT-V104 supp 6	1.9878	1.94158	1.971	1.86163	1.81219
463	Tubing HTT-V104 supp 75	1.96055	1.91751	1.94534	1.83903	1.82716
471	Filling line @ FP IF	55.99668	53.55684	54.84753	50.66067	196.64113
472	Filling line	52.38998	50.13118	51.32609	47.44317	171.48359
473	Filling line	48.65572	46.56873	47.67438	44.08043	150.4018
474	Filling line supp 35	44.71732	42.80077	43.81725	40.49937	131.56945
475	Filling line	41.32196	39.56161	40.49517	37.43848	117.0193
476	Filling line	37.70722	36.09099	36.94788	34.13939	104.43219
477	Filling line	33.72814	32.25479	33.03809	30.46711	92.8917
478	Filling line supp 5	29.14569	27.81358	28.52198	26.18905	81.67948
479	Filling line	24.46621	23.28149	23.91168	21.83548	71.12256
480	Filling line supp 4	18.23086	17.18619	17.7428	15.93077	59.76138
481	Filling line	15.6502	14.73792	15.2241	13.64284	52.39494
482	Filling line	12.33358	11.59608	11.98921	10.70788	44.10393
483	Filling line supp 2	6.94248	6.40511	6.69302	5.76521	33.57047
484	Filling line @ V102	5.36506	4.96768	5.17991	4.49709	25.84296
485	Filling line supp 3	2.2745	2.19642	2.24214	2.09345	12.09198
494	Filling line supp 31	8.16599	7.52044	7.86628	6.7522	45.72469
495	Filling line supp 22	4.13902	3.77219	3.9682	3.36094	42.22931
496	Filling line supp 23	3.48091	3.23876	3.37034	2.99311	43.67908
497	Filling line supp 24	6.12345	5.68791	5.9225	5.26754	44.6034
498	Filling line supp 25	9.5201	9.01067	9.2832	8.52767	46.54152
499	Filling line supp 26	14.68148	14.02514	14.37526	13.40979	50.67356
505	Supp bracket L1 entrance	2.15272	2.0945	2.12944	2.00863	6.97376
510	Vline wall HTT-L1 sup 16	1.65266	1.64144	1.65259	1.59765	16.09661
511	Vline wall HTT-L1	1.65952	1.64772	1.65916	1.60392	16.76141
512	Vline wall HTT-L1 sup 17	1.66176	1.64984	1.66133	1.60624	14.15135
513	Vline wall HTT-L1 sup L1	1.66623	1.65398	1.66561	1.6105	1.88723
514	Vline wall HTT-L1 @L1 IF	1.93067	1.92889	1.93475	1.85061	2.07828
520	Vline wall PACS I/F 1	2.4378	2.4302	2.43909	2.23993	4.19592
521	Vline wall PACS I/F 1	2.56632	2.55553	2.56615	2.33561	5.02662
522	Vline wall PACS I/F 1	2.5193	2.51243	2.52088	2.30751	4.38624
523	Vline wall PACSI/F1/2	2.4439	2.4478	2.45026	2.27326	2.98276
524	Vline wall PACSI/F1/2	2.53289	2.53682	2.53923	2.34287	3.11598
525	Vline wall PACS I/F 2	2.89316	2.88128	2.89257	2.59045	5.82744
526	Vline wall PACS I/F 2	2.96684	2.95068	2.96436	2.63931	6.52682
527	Vline wall PACS I/F 2	2.94385	2.93106	2.94302	2.62793	5.87971
528	Vline wall PACSI/F2/3	2.91795	2.91199	2.92074	2.61961	4.35645
529	Vline wall PACSI/F2/3	2.99473	2.98643	2.99708	2.67347	4.69301
530	Vline wall PACS I/F 3	3.11375	3.09643	3.11221	2.74869	6.42803
531	Vline wall PACS I/F 3	3.15418	3.13324	3.15096	2.77347	7.11355
532	Vline wall PACS I/F 3	3.15188	3.13432	3.15075	2.77798	6.54122
533	Vline wall PACS-SPIRE	3.16745	3.15502	3.16957	2.80091	5.83261
534	Vline wall PACS-SPIRE	3.26185	3.25861	3.26961	2.89945	5.53731
535	Vline wall PACS-SPIRE	3.68391	3.69297	3.69969	3.28712	6.12996

Node	LABEL	Orbit hot T [K]	Orbit cold T [K]	Orbit avg T [K]	Orbit Safe T [K]	Ground T [K]
536	Vline wall SPIRE IF12	4.49179	4.48244	4.50056	3.95068	9.97074
537	Vline wall SPIRE IF12	4.65986	4.64441	4.66607	4.0856	10.99124
538	Vline wall SPIRE IF12	4.64309	4.63351	4.65237	4.08253	10.30617
539	Vline wall SPIRE-HIFI	4.75892	4.77966	4.78531	4.24377	8.19274
543	Vline wall SPIRE-HIFI	5.44175	5.49295	5.48676	4.9048	8.34578
544	Vline wall HIFI I/F	5.66957	5.71911	5.71481	5.10215	8.56458
545	Vline wall HIFI I/F	5.80896	5.85618	5.85355	5.22072	8.73574
546	Vline wall HIFI I/F	5.79814	5.8486	5.84488	5.21631	8.64281
550	Vline wall L1-L2	5.79708	5.852	5.84688	5.22252	8.53551
551	Vline wall L1-L2	5.91583	5.99136	5.97818	5.36802	8.48793
552	Vline wall L1-L2	6.3909	6.50055	6.47222	5.86675	8.53191
553	Vline wall L1-L2	7.98716	8.1062	8.07364	7.33936	9.07295
554	Vline wall L1-L2	11.99281	11.95793	12.00142	10.67091	13.96017
560	Vline wall Lev.2 OB	12.66668	12.58219	12.65053	11.1768	16.75276
561	Vline wall Lev.2 OB	12.95365	12.84469	12.92537	11.385	19.14803
562	Vline wall Lev.2 OB	13.0178	12.90346	12.98694	11.43797	20.09267
563	Vline wall Lev.2 OB	12.99396	12.88118	12.96395	11.41302	20.22817
570	Vline wall L2-L3	13.04864	12.94692	13.0266	11.41632	20.22624
571	Vline wall L2-L3	13.31399	13.24139	13.31231	11.43071	20.26933
580	Vline wall PM JFET	13.47444	13.40919	13.47904	11.4385	20.38102
581	Vline wall PM JFET	13.52568	13.46152	13.53138	11.44092	20.43456
582	Vline wall PM JFET	13.52351	13.46143	13.53113	11.44112	20.40764
583	Vline wall PM/SM JFET	13.53216	13.47899	13.54849	11.44355	20.35873
584	Vline wall SM JFET	13.5623	13.51696	13.58683	11.448	20.3909
585	Vline wall SM JFET	13.56935	13.52481	13.59484	11.44891	20.40245
586	Vline wall SM JFET	13.56662	13.52357	13.59358	11.44885	20.39597
590	Vline wall L3-TS1	13.55802	13.52033	13.59043	11.44895	20.3827
591	Vline wall L3-TS1	13.59986	13.5724	13.64192	11.52646	20.38694
592	Vline wall L3-TS1	23.89937	23.59828	23.7854	23.08326	26.54867
610	Vline wall TS1-2 pymz	34.67543	33.58575	34.16568	32.59148	81.8815
611	Vline wall TS2-3 pymz	45.76053	43.91855	44.87671	42.51907	146.05189
612	Vline w. TS3-CVV pymz	55.23775	52.81396	54.07796	50.49535	218.75707
620	Vline wall TS1-2 mypz	34.66013	33.5708	34.15058	32.5749	82.50597
621	Vline wall TS2-3 mypz	45.76181	43.91921	44.8777	42.51969	146.84383
622	Vline w. TS3-CVV mypz	55.23776	52.81397	54.07798	50.49536	218.75707
643	MLI on filling port	46.55467	45.1365	45.89014	43.43828	138.08604
644	MLI on filling port	46.45398	45.03959	45.79125	43.34558	136.70574
1001	Susp bolt lo pZmY TS1	34.94179	33.8104	34.41117	32.77539	90.35767
1002	Susp bolt lo pZmY TS1	35.13076	33.98424	34.5927	32.92873	92.58641
1003	Susp bolt lo mZmY TS1	35.18916	34.03794	34.64874	32.97966	93.23865
1004	Susp bolt lo mZmY TS1	35.27656	34.11999	34.73355	33.05474	93.61595
1005	Susp bolt lo mZpY TS1	35.17765	34.02914	34.63858	32.97406	92.44032
1006	Susp bolt lo mZpY TS1	34.94126	33.81076	34.41104	32.77937	90.00614
1007	Susp bolt lo pZpY TS1	34.70377	33.59228	34.18291	32.58202	87.56211
1008	Susp bolt lo pZpY TS1	34.69066	33.57975	34.1701	32.56999	87.60643
1011	@TS 1 lower bulk 1	34.22456	33.16398	33.72917	32.1753	78.81152
1012	@TS 1 lower bulk 2	34.38599	33.31186	33.88393	32.30615	81.00854
1013	@TS 1 lower bulk 3	34.47523	33.39366	33.9695	32.3802	82.2726
1014	@TS 1 lower bulk 4	34.51589	33.43175	34.00891	32.41553	82.49485
1015	@TS 1 lower bulk 5	34.42521	33.34894	33.92209	32.34268	81.09069
1016	@TS 1 lower bulk 6	34.23937	33.17825	33.7437	32.19079	78.73584
1017	@TS 1 lower bulk 7	34.07241	33.02504	33.58352	32.05314	76.78748
1018	@TS 1 lower bulk 8	34.06408	33.0171	33.57539	32.04518	76.79544
1021	@TS 1 lower cyl 1	34.15589	33.10299	33.66439	32.11931	76.22368
1022	@TS 1 lower cyl 2	34.44125	33.36437	33.93797	32.34747	80.48469

Node	LABEL	Orbit hot T [K]	Orbit cold T [K]	Orbit avg T [K]	Orbit Safe T [K]	Ground T [K]
1023	@TS 1 lower cyl 3	34.49404	33.41146	33.98787	32.39346	82.11878
1024	@TS 1 lower cyl 4	34.52258	33.43849	34.01565	32.42022	81.9903
1025	@TS 1 lower cyl 5	34.46072	33.38364	33.95727	32.37258	80.12765
1026	@TS 1 lower cyl 6	34.13497	33.0843	33.64449	32.10739	75.76116
1027	@TS 1 lower cyl 7	33.72038	32.70452	33.24708	31.76533	70.84884
1028	@TS 1 lower cyl 8	33.71465	32.69894	33.24144	31.75971	70.90403
1031	@TS 1 upper cyl 1	34.09831	33.05055	33.60939	32.07057	75.41157
1032	@TS 1 upper cyl 2	34.41946	33.3443	33.91708	32.32628	80.90576
1033	@TS 1 upper cyl 3	34.44832	33.36909	33.94383	32.35299	82.34088
1034	@TS 1 upper cyl 4	34.45266	33.37388	33.94837	32.36052	81.4331
1035	@TS 1 upper cyl 5	34.41921	33.3458	33.91761	32.33672	79.476
1036	@TS 1 upper cyl 6	34.09241	33.04579	33.604	32.071	74.82058
1037	@TS 1 upper cyl 7	33.57785	32.57447	33.11077	31.64705	68.74148
1038	@TS 1 upper cyl 8	33.57033	32.56725	33.10341	31.64021	68.84303
1041	@TS 1 upper bulk 1	34.08781	33.039	33.59832	32.05946	76.85152
1042	@TS 1 upper bulk 2	34.28978	33.22365	33.79176	32.22244	79.97515
1043	@TS 1 upper bulk 3	34.36933	33.29613	33.86779	32.28851	81.31691
1044	@TS 1 upper bulk 4	34.36973	33.29696	33.86838	32.29113	80.8931
1045	@TS 1 upper bulk 5	34.28882	33.22373	33.79126	32.22699	79.19415
1046	@TS 1 upper bulk 6	34.08528	33.03737	33.5962	32.06128	76.32696
1047	@TS 1 upper bulk 7	33.86234	32.83307	33.38246	31.87784	73.63484
1048	@TS 1 upper bulk 8	33.86181	32.8323	33.38183	31.87622	73.80207
1061	Susp bolt up pZmY TS1	34.40667	33.32916	33.90295	32.32758	79.87926
1062	Susp bolt up pZmY TS1	34.82277	33.71187	34.30282	32.65129	86.25697
1063	Susp bolt up mZmY TS1	34.69499	33.59038	34.17784	32.55837	86.43733
1064	Susp bolt up mZmY TS1	34.71657	33.61105	34.19895	32.58012	85.76351
1065	Susp bolt up mZpY TS1	34.8449	33.73442	34.325	32.68882	85.32187
1066	Susp bolt up mZpY TS1	34.30599	33.23627	33.80595	32.25071	78.6773
1067	Susp bolt up pZpY TS1	33.36447	32.37514	32.90426	31.47065	67.87668
1068	Susp bolt up pZpY TS1	33.33682	32.34919	32.87744	31.44977	67.82758
1090	TS 1 LO Baffles.	34.45389	33.37236	33.94832	32.35193	86.9425
1111	TS 1 lower bulk MLI 1	36.65849	35.29395	36.01139	34.11886	127.28388
1112	TS 1 lower bulk MLI 2	36.76773	35.39763	36.11793	34.21365	126.5857
1113	TS 1 lower bulk MLI 3	36.81917	35.4476	36.16865	34.2617	125.3844
1114	TS 1 lower bulk MLI 4	36.85058	35.47774	36.19946	34.29003	125.05889
1115	TS 1 lower bulk MLI 5	36.79789	35.42702	36.14771	34.24295	125.83952
1116	TS 1 lower bulk MLI 6	36.6695	35.30507	36.02243	34.13112	126.61461
1117	TS 1 lower bulk MLI 7	36.54854	35.1909	35.90479	34.02606	127.07407
1118	TS 1 lower bulk MLI 8	36.54227	35.1847	35.89856	34.01974	127.33166
1121	TS 1 lower cyl MLI 1	37.69613	36.22131	36.99478	34.98014	130.95308
1122	TS 1 lower cyl MLI 2	37.85082	36.37097	37.14707	35.11742	129.49331
1123	TS 1 lower cyl MLI 3	37.9086	36.42848	37.20485	35.17327	126.84282
1124	TS 1 lower cyl MLI 4	37.83271	36.36174	37.13328	35.12166	124.46234
1125	TS 1 lower cyl MLI 5	37.8646	36.38575	37.16129	35.13608	127.70846
1126	TS 1 lower cyl MLI 6	37.68138	36.20831	36.98083	34.97157	129.64435
1127	TS 1 lower cyl MLI 7	37.41782	35.95765	36.72343	34.73897	130.38019
1128	TS 1 lower cyl MLI 8	37.41425	35.95385	36.71975	34.73507	130.86606
1131	TS 1 upper cyl MLI 1	36.41915	35.07646	35.78294	33.91833	122.77552
1132	TS 1 upper cyl MLI 2	36.6499	35.29326	36.00694	34.1117	124.37271
1133	TS 1 upper cyl MLI 3	36.62339	35.27234	35.98312	34.10196	120.81647
1134	TS 1 upper cyl MLI 4	36.61844	35.26993	35.97938	34.10328	117.01516
1135	TS 1 upper cyl MLI 5	36.64732	35.29359	36.0057	34.11957	119.5917
1136	TS 1 upper cyl MLI 6	36.41387	35.07257	35.7783	33.91861	120.97756
1137	TS 1 upper cyl MLI 7	36.01771	34.70141	35.39413	33.57908	120.85443
1138	TS 1 upper cyl MLI 8	36.012	34.69565	35.3884	33.57355	121.43618

Node	LABEL	Orbit hot T [K]	Orbit cold T [K]	Orbit avg T [K]	Orbit Safe T [K]	Ground T [K]
1141	TS 1 upper bulk MLI 1	37.11392	35.69019	36.43755	34.48626	130.77571
1142	TS 1 upper bulk MLI 2	37.24413	35.81361	36.56445	34.59883	130.95297
1143	TS 1 upper bulk MLI 3	37.27968	35.84904	36.59993	34.63453	129.64221
1144	TS 1 upper bulk MLI 4	37.27732	35.84776	36.59808	34.63505	128.35805
1145	TS 1 upper bulk MLI 5	37.24163	35.81273	36.5627	34.60156	128.91988
1146	TS 1 upper bulk MLI 6	37.11129	35.68867	36.43543	34.48739	129.59075
1147	TS 1 upper bulk MLI 7	36.95841	35.54375	36.28622	34.35397	129.91176
1148	TS 1 upper bulk MLI 8	36.95826	35.54327	36.28592	34.35282	130.29966
1211	TS 1 low strap I/F 1	34.21739	33.158	33.72261	32.17011	78.14212
1212	TS 1 low strap I/F 2	34.42913	33.35198	33.92562	32.34049	81.15868
1213	TS 1 low strap I/F 3	34.5029	33.41908	33.99607	32.40264	82.55139
1214	TS 1 low strap I/F 4	34.59982	33.50963	34.08991	32.4852	83.18118
1215	TS 1 low strap I/F 5	34.48407	33.40398	33.9791	32.39222	81.2695
1216	TS 1 low strap I/F 6	34.22048	33.1615	33.72587	32.17683	77.93155
1217	TS 1 low strap I/F 7	33.95767	32.92068	33.47394	31.96005	74.85534
1218	TS 1 low strap I/F 8	33.94243	32.90624	33.45909	31.94638	74.82188
1221	TS 1 upp strap I/F 1	34.20905	33.15395	33.71655	32.16658	74.21166
1222	TS 1 upp strap I/F 2	34.63237	33.54262	34.12297	32.49522	81.29256
1223	TS 1 upp strap I/F 3	34.49607	33.41296	33.98968	32.39352	82.35106
1224	TS 1 upp strap I/F 4	34.51184	33.42832	34.00522	32.4106	81.73409
1225	TS 1 upp strap I/F 5	34.64271	33.55445	34.13389	32.52308	80.41544
1226	TS 1 upp strap I/F 6	34.11179	33.06446	33.62295	32.09343	73.11114
1227	TS 1 upp strap I/F 7	33.13732	32.17346	32.68982	31.28804	61.36777
1228	TS 1 upp strap I/F 8	33.11016	32.14803	32.66351	31.26724	61.23714
2001	Susp bolt lo pZmY TS2	46.21393	44.35712	45.3263	42.84455	147.92087
2002	Susp bolt lo pZmY TS2	46.16471	44.31339	45.27973	42.80901	147.37846
2003	Susp bolt lo mZmY TS2	46.05474	44.21533	45.17546	42.72954	145.48238
2004	Susp bolt lo mZmY TS2	46.04354	44.20637	45.16523	42.7222	144.98144
2005	Susp bolt lo mZpY TS2	46.12612	44.28029	45.24365	42.78223	146.394
2006	Susp bolt lo mZpY TS2	46.1741	44.32227	45.28881	42.81722	147.14815
2007	Susp bolt lo pZpY TS2	46.20158	44.34616	45.31452	42.83642	147.03573
2008	Susp bolt lo pZpY TS2	46.21152	44.35486	45.32391	42.84321	147.32775
2011	@TS 2 lower bulk 1	45.51117	43.68847	44.63878	42.28015	145.36123
2012	@TS 2 lower bulk 2	45.45544	43.63877	44.58595	42.23996	144.14602
2013	@TS 2 lower bulk 3	45.39394	43.58424	44.5278	42.19572	142.49881
2014	@TS 2 lower bulk 4	45.39278	43.58365	44.5269	42.19509	142.07288
2015	@TS 2 lower bulk 5	45.454	43.63845	44.58503	42.23942	143.2676
2016	@TS 2 lower bulk 6	45.5094	43.68767	44.63746	42.27933	144.61017
2017	@TS 2 lower bulk 7	45.53979	43.71447	44.66612	42.3011	145.4812
2018	@TS 2 lower bulk 8	45.5405	43.71483	44.66667	42.30144	145.77192
2021	@TS 2 lower cyl 1	45.5001	43.67558	44.62674	42.26993	145.41521
2022	@TS 2 lower cyl 2	45.4072	43.59261	44.53863	42.20308	143.24233
2023	@TS 2 lower cyl 3	45.23413	43.43894	44.37488	42.07852	138.53213
2024	@TS 2 lower cyl 4	45.23012	43.43646	44.37158	42.07596	137.38766
2025	@TS 2 lower cyl 5	45.40854	43.59593	44.5409	42.20506	141.31255
2026	@TS 2 lower cyl 6	45.49876	43.67567	44.62607	42.26971	144.04201
2027	@TS 2 lower cyl 7	45.5383	43.71043	44.66331	42.29787	145.41949
2028	@TS 2 lower cyl 8	45.53899	43.71062	44.66377	42.2981	145.93798
2031	@TS 2 upper cyl 1	45.48127	43.65067	44.60483	42.24852	147.39905
2032	@TS 2 upper cyl 2	45.39759	43.57438	44.52479	42.18648	147.9429
2033	@TS 2 upper cyl 3	45.22069	43.41726	44.35739	42.05916	143.15187
2034	@TS 2 upper cyl 4	45.1904	43.39301	44.32991	42.03954	138.66083
2035	@TS 2 upper cyl 5	45.38914	43.571	44.51866	42.18379	142.47799
2036	@TS 2 upper cyl 6	45.47916	43.65048	44.60359	42.24823	145.39559
2037	@TS 2 upper cyl 7	45.51529	43.68224	44.63762	42.27395	146.61954

Node	LABEL	Orbit hot T [K]	Orbit cold T [K]	Orbit avg T [K]	Orbit Safe T [K]	Ground T [K]
2038	@TS 2 upper cyl 8	45.51606	43.68242	44.63812	42.27414	147.27459
2041	@TS 2 upper bulk 1	45.46938	43.6317	44.58935	42.23193	148.62134
2042	@TS 2 upper bulk 2	45.4236	43.59038	44.54574	42.19838	148.32772
2043	@TS 2 upper bulk 3	45.36174	43.53549	44.48722	42.15387	146.61479
2044	@TS 2 upper bulk 4	45.35439	43.52987	44.48067	42.14933	145.22688
2045	@TS 2 upper bulk 5	45.41865	43.58761	44.54179	42.19615	146.15902
2046	@TS 2 upper bulk 6	45.46722	43.63078	44.58775	42.23115	147.37562
2047	@TS 2 upper bulk 7	45.49062	43.6514	44.60982	42.24787	148.13254
2048	@TS 2 upper bulk 8	45.49126	43.65165	44.61028	42.24809	148.53912
2050	@TS 2 baffle	45.48378	43.6313	44.5963	42.23137	150.16149
2061	Susp bolt up pZmY TS2	45.73383	43.89192	44.85237	42.45044	146.8839
2062	Susp bolt up pZmY TS2	45.65343	43.81957	44.77588	42.39251	145.48836
2063	Susp bolt up mZmY TS2	45.25562	43.46542	44.39902	42.10544	136.06538
2064	Susp bolt up mZmY TS2	45.24004	43.45379	44.38526	42.09465	133.83852
2065	Susp bolt up mZpY TS2	45.65611	43.82611	44.78036	42.39693	142.44795
2066	Susp bolt up mZpY TS2	45.72349	43.88433	44.84331	42.44436	145.17734
2067	Susp bolt up pZpY TS2	45.742	43.90031	44.8606	42.45665	145.72773
2068	Susp bolt up pZpY TS2	45.74431	43.90187	44.86257	42.4579	146.39551
2090	TS 2 LO Baffles.	45.43629	43.59862	44.55704	42.20119	166.30739
2111	TS 2 lower bulk MLI 1	50.04357	47.76244	48.95008	45.77523	205.73824
2112	TS 2 lower bulk MLI 2	50.05341	47.76942	48.9586	45.77659	208.18488
2113	TS 2 lower bulk MLI 3	50.03582	47.75258	48.94137	45.76038	209.46994
2114	TS 2 lower bulk MLI 4	50.02748	47.7457	48.9337	45.75509	209.43306
2115	TS 2 lower bulk MLI 5	50.03361	47.75303	48.94039	45.76415	208.11003
2116	TS 2 lower bulk MLI 6	50.02407	47.74617	48.93208	45.76301	205.67076
2117	TS 2 lower bulk MLI 7	50.00026	47.72604	48.90998	45.75077	202.96522
2118	TS 2 lower bulk MLI 8	50.00782	47.73236	48.91697	45.7555	203.00259
2121	TS 2 lower cyl MLI 1	50.61914	48.30336	49.50926	46.26469	204.85498
2122	TS 2 lower cyl MLI 2	50.649	48.32706	49.53629	46.27643	209.20636
2123	TS 2 lower cyl MLI 3	50.66322	48.34171	49.55097	46.2818	211.2866
2124	TS 2 lower cyl MLI 4	50.58034	48.26371	49.47012	46.2202	210.97854
2125	TS 2 lower cyl MLI 5	50.62265	48.30571	49.51227	46.26017	209.09462
2126	TS 2 lower cyl MLI 6	50.59292	48.28157	49.48512	46.24827	204.7834
2127	TS 2 lower cyl MLI 7	50.46139	48.1671	49.3615	46.16813	196.40624
2128	TS 2 lower cyl MLI 8	50.47116	48.17527	49.37053	46.17428	196.50953
2131	TS 2 upper cyl MLI 1	49.7668	47.49732	48.67875	45.53911	207.18193
2132	TS 2 upper cyl MLI 2	49.75472	47.48344	48.6659	45.52327	209.51508
2133	TS 2 upper cyl MLI 3	49.67004	47.40495	48.58415	45.45555	210.34816
2134	TS 2 upper cyl MLI 4	49.64545	47.3845	48.56145	45.43905	210.02036
2135	TS 2 upper cyl MLI 5	49.72986	47.46459	48.64382	45.50917	209.13578
2136	TS 2 upper cyl MLI 6	49.74689	47.48151	48.66077	45.52738	207.26442
2137	TS 2 upper cyl MLI 7	49.72967	47.46712	48.64483	45.51967	204.46681
2138	TS 2 upper cyl MLI 8	49.73723	47.47321	48.6517	45.52419	204.48178
2141	TS 2 upper bulk MLI 1	50.28125	47.9729	49.17479	45.9602	210.41132
2142	TS 2 upper bulk MLI 2	50.28317	47.97324	49.17601	45.95747	211.91108
2143	TS 2 upper bulk MLI 3	50.26195	47.95346	49.15548	45.93942	212.69486
2144	TS 2 upper bulk MLI 4	50.25125	47.94469	49.14568	45.93264	212.61194
2145	TS 2 upper bulk MLI 5	50.26409	47.95797	49.15871	45.94605	211.81207
2146	TS 2 upper bulk MLI 6	50.26453	47.95938	49.15958	45.95015	210.43177
2147	TS 2 upper bulk MLI 7	50.25716	47.95313	49.1527	45.94725	209.01477
2148	TS 2 upper bulk MLI 8	50.26367	47.95843	49.15864	45.95118	209.0079
2211	TS 2 low strap I/F 1	45.52829	43.70357	44.65492	42.29309	145.47409
2212	TS 2 low strap I/F 2	45.45607	43.63911	44.58645	42.24106	143.8538
2213	TS 2 low strap I/F 3	45.34295	43.53869	44.47943	42.15965	140.83139
2214	TS 2 low strap I/F 4	45.3402	43.537	44.47716	42.15794	140.08314

Node	LABEL	Orbit hot T [K]	Orbit cold T [K]	Orbit avg T [K]	Orbit Safe T [K]	Ground T [K]
2215	TS 2 low strap I/F 5	45.45471	43.6394	44.58585	42.24083	142.50195
2216	TS 2 low strap I/F 6	45.52551	43.7021	44.65275	42.29171	144.44384
2217	TS 2 low strap I/F 7	45.55992	43.73239	44.68518	42.31627	145.50737
2218	TS 2 low strap I/F 8	45.56092	43.73293	44.68597	42.31676	145.90012
2221	TS 2 upp strap I/F 1	45.50974	43.68109	44.6343	42.2747	146.14767
2222	TS 2 upp strap I/F 2	45.41446	43.59555	44.54375	42.20645	143.84437
2223	TS 2 upp strap I/F 3	44.99441	43.2222	44.14613	41.90412	132.53124
2224	TS 2 upp strap I/F 4	44.98	43.21165	44.13351	41.89401	129.9478
2225	TS 2 upp strap I/F 5	45.42457	43.60871	44.55528	42.21568	140.28726
2226	TS 2 upp strap I/F 6	45.5075	43.68065	44.63289	42.2741	144.1673
2227	TS 2 upp strap I/F 7	45.54467	43.71322	44.66784	42.30031	145.78659
2228	TS 2 upp strap I/F 8	45.54558	43.71354	44.66848	42.30062	146.58075
3001	Susp bolt lo pZmY TS3	55.37807	52.93618	54.21331	50.5175	217.49075
3002	Susp bolt lo pZmY TS3	55.38903	52.94745	54.2245	50.52251	220.15162
3003	Susp bolt lo mZmY TS3	55.23506	52.80777	54.07728	50.40784	221.30339
3004	Susp bolt lo mZmY TS3	55.13978	52.72471	53.9872	50.33918	221.24076
3005	Susp bolt lo mZpY TS3	55.09271	52.68222	53.94225	50.30628	220.04138
3006	Susp bolt lo mZpY TS3	55.096	52.68238	53.94452	50.31702	217.40938
3007	Susp bolt lo pZpY TS3	55.16722	52.74464	54.01113	50.37146	213.01645
3008	Susp bolt lo pZpY TS3	55.23996	52.81079	54.08096	50.42378	213.07958
3011	@TS 3 lower bulk 1	54.83305	52.42871	53.68415	50.12469	213.94766
3012	@TS 3 lower bulk 2	54.89858	52.48818	53.74691	50.16888	216.67409
3013	@TS 3 lower bulk 3	54.92114	52.50891	53.76864	50.18372	218.17324
3014	@TS 3 lower bulk 4	54.90766	52.49703	53.75588	50.17432	218.16402
3015	@TS 3 lower bulk 5	54.86536	52.4588	53.71544	50.14575	216.65898
3016	@TS 3 lower bulk 6	54.80053	52.3999	53.65333	50.1022	213.93416
3017	@TS 3 lower bulk 7	54.73229	52.33785	53.58793	50.05616	210.94507
3018	@TS 3 lower bulk 8	54.7449	52.34904	53.59989	50.06485	210.96132
3021	@TS 3 lower cyl 1	54.78803	52.38816	53.64119	50.09556	211.394
3022	@TS 3 lower cyl 2	54.89733	52.48716	53.74579	50.16911	216.14609
3023	@TS 3 lower cyl 3	54.92622	52.51377	53.77366	50.18801	218.36189
3024	@TS 3 lower cyl 4	54.90884	52.4986	53.75728	50.17608	218.34135
3025	@TS 3 lower cyl 5	54.85531	52.45028	53.70613	50.1401	216.13999
3026	@TS 3 lower cyl 6	54.74783	52.35278	53.60323	50.06795	211.40666
3027	@TS 3 lower cyl 7	54.51362	52.1407	53.37915	49.909	202.37745
3028	@TS 3 lower cyl 8	54.52859	52.1539	53.3933	49.91929	202.44932
3031	@TS 3 upper cyl 1	54.85407	52.44676	53.70389	50.13925	216.32019
3032	@TS 3 upper cyl 2	54.91305	52.50049	53.76049	50.17903	218.80914
3033	@TS 3 upper cyl 3	54.92858	52.51522	53.77568	50.18932	220.1097
3034	@TS 3 upper cyl 4	54.91279	52.50158	53.76089	50.17869	220.09945
3035	@TS 3 upper cyl 5	54.87559	52.46797	53.72533	50.15367	218.8539
3036	@TS 3 upper cyl 6	54.81946	52.4166	53.67136	50.11581	216.58577
3037	@TS 3 upper cyl 7	54.75233	52.35524	53.60684	50.07025	213.43383
3038	@TS 3 upper cyl 8	54.76555	52.36677	53.61928	50.0792	213.38961
3041	@TS 3 upper bulk 1	54.87089	52.46135	53.71968	50.15027	218.11371
3042	@TS 3 upper bulk 2	54.91005	52.49716	53.75733	50.17676	219.74127
3043	@TS 3 upper bulk 3	54.92321	52.5097	53.77023	50.18571	220.69815
3044	@TS 3 upper bulk 4	54.91118	52.49935	53.75899	50.1777	220.70293
3045	@TS 3 upper bulk 5	54.88218	52.47315	53.73127	50.15817	219.78623
3046	@TS 3 upper bulk 6	54.84471	52.43875	53.69518	50.13278	218.22525
3047	@TS 3 upper bulk 7	54.81392	52.41027	53.66543	50.11179	216.65204
3048	@TS 3 upper bulk 8	54.8243	52.41924	53.67514	50.11873	216.61463
3061	Susp bolt up pZmY TS3	55.04254	52.6191	53.88534	50.26871	216.79675
3062	Susp bolt up pZmY TS3	55.09181	52.66492	53.93311	50.30162	219.63201
3063	Susp bolt up mZmY TS3	55.02547	52.60665	53.87066	50.25365	220.44187

Node	LABEL	Orbit hot T [K]	Orbit cold T [K]	Orbit avg T [K]	Orbit Safe T [K]	Ground T [K]
3064	Susp bolt up mZmY TS3	54.97492	52.56322	53.82324	50.21853	220.28727
3065	Susp bolt up mZpY TS3	54.94411	52.53511	53.79363	50.19785	219.44743
3066	Susp bolt up mZpY TS3	54.90209	52.49496	53.7526	50.17217	216.80327
3067	Susp bolt up pZpY TS3	54.85032	52.44547	53.70158	50.13729	211.96602
3068	Susp bolt up pZpY TS3	54.88911	52.48005	53.73846	50.16423	212.01931
3111	TS 3 lower bulk MLI 1	64.56979	61.32524	63.02808	57.39722	286.79037
3112	TS 3 lower bulk MLI 2	64.26556	61.04454	62.73344	57.18688	286.92988
3113	TS 3 lower bulk MLI 3	63.64837	60.46931	62.13343	56.71383	287.00851
3114	TS 3 lower bulk MLI 4	63.28419	60.12416	61.77413	56.41877	287.00802
3115	TS 3 lower bulk MLI 5	63.25092	60.09155	61.74098	56.3943	286.92909
3116	TS 3 lower bulk MLI 6	63.58223	60.39427	62.0625	56.66505	286.78969
3117	TS 3 lower bulk MLI 7	64.25866	61.02102	62.71807	57.18225	286.64185
3118	TS 3 lower bulk MLI 8	64.5712	61.32069	63.02648	57.39818	286.64264
3121	TS 3 lower cyl MLI 1	63.92724	60.72098	62.40681	56.98624	286.8483
3122	TS 3 lower cyl MLI 2	63.6231	60.46004	62.12316	56.78139	287.07992
3123	TS 3 lower cyl MLI 3	62.75231	59.6963	61.30288	56.19695	286.89678
3124	TS 3 lower cyl MLI 4	62.19374	59.19638	60.76847	55.78083	287.19138
3125	TS 3 lower cyl MLI 5	62.06574	59.08222	60.64704	55.68667	287.07962
3126	TS 3 lower cyl MLI 6	62.41453	59.3796	60.97441	55.95348	286.8489
3127	TS 3 lower cyl MLI 7	63.44578	60.27981	61.94285	56.64645	286.44367
3128	TS 3 lower cyl MLI 8	63.84271	60.63675	62.32191	56.92211	286.44672
3131	TS 3 upper cyl MLI 1	62.65278	59.49997	61.15882	55.98738	285.29061
3132	TS 3 upper cyl MLI 2	62.38585	59.27743	60.91299	55.79041	285.45757
3133	TS 3 upper cyl MLI 3	61.69795	58.68619	60.26951	55.32309	285.54672
3134	TS 3 upper cyl MLI 4	60.84531	57.95221	59.47319	54.75762	285.54601
3135	TS 3 upper cyl MLI 5	60.78541	57.89961	59.41672	54.72513	285.46061
3136	TS 3 upper cyl MLI 6	61.48244	58.49879	60.06706	55.20228	285.3082
3137	TS 3 upper cyl MLI 7	62.29424	59.19261	60.82345	55.75893	285.10292
3138	TS 3 upper cyl MLI 8	62.61044	59.45961	61.11696	55.96439	285.10009
3141	TS 3 upper bulk MLI 1	63.29177	60.10452	61.7845	56.58428	286.83195
3142	TS 3 upper bulk MLI 2	62.99132	59.84697	61.50433	56.3622	286.92141
3143	TS 3 upper bulk MLI 3	62.47199	59.40252	61.02014	56.01048	286.9748
3144	TS 3 upper bulk MLI 4	61.71813	58.74374	60.31093	55.48277	286.97506
3145	TS 3 upper bulk MLI 5	61.67474	58.70582	60.27013	55.4594	286.9239
3146	TS 3 upper bulk MLI 6	62.36241	59.30611	60.91651	55.95232	286.83802
3147	TS 3 upper bulk MLI 7	62.92445	59.78525	61.43942	56.33424	286.75303
3148	TS 3 upper bulk MLI 8	63.26788	60.08293	61.76154	56.57432	286.75103
3211	TS 3 low strap I/F 1	54.82928	52.4258	53.68083	50.12349	212.81854
3212	TS 3 low strap I/F 2	54.91467	52.50326	53.7626	50.18093	216.54298
3213	TS 3 low strap I/F 3	54.93435	52.52145	53.78162	50.19341	218.38354
3214	TS 3 low strap I/F 4	54.91615	52.50552	53.76443	50.18075	218.36672
3215	TS 3 low strap I/F 5	54.8681	52.46214	53.71852	50.14835	216.52876
3216	TS 3 low strap I/F 6	54.78443	52.38608	53.63836	50.09244	212.81539
3217	TS 3 low strap I/F 7	54.63862	52.25382	53.49873	49.99375	206.80168
3218	TS 3 low strap I/F 8	54.65446	52.26788	53.51375	50.00471	206.84699
3221	TS 3 upp strap I/F 1	54.84186	52.43661	53.69264	50.13195	214.17019
3222	TS 3 upp strap I/F 2	54.92169	52.50914	53.76915	50.18564	217.67929
3223	TS 3 upp strap I/F 3	54.93592	52.5226	53.78306	50.19447	219.35503
3224	TS 3 upp strap I/F 4	54.91645	52.50569	53.76475	50.1811	219.33151
3225	TS 3 upp strap I/F 5	54.87275	52.46623	53.72299	50.15175	217.68765
3226	TS 3 upp strap I/F 6	54.7957	52.39598	53.64906	50.10023	214.30837
3227	TS 3 upp strap I/F 7	54.6579	52.27079	53.517	50.00687	208.47107
3228	TS 3 upp strap I/F 8	54.67408	52.28506	53.5323	50.01799	208.48371
4011	@CVV LOW BULK 1	69.40526	66.1076	67.8431	61.80335	293
4012	@CVV LOW BULK 2	68.97975	65.7054	67.42658	61.48634	293



Thermal Report

Herschel

Node	LABEL	Orbit hot T [K]	Orbit cold T [K]	Orbit avg T [K]	Orbit Safe T [K]	Ground T [K]
4013	@CVV LOW BULK 3	68.15236	64.91665	66.61399	60.80838	293
4014	@CVV LOW BULK 4	67.6704	64.44929	66.13347	60.39043	293
4015	@CVV LOW BULK 5	67.64375	64.42216	66.10638	60.37034	293
4016	@CVV LOW BULK 6	68.11451	64.86375	66.56847	60.78107	293
4017	@CVV LOW BULK 7	69.03738	65.73937	67.47247	61.53624	293
4018	@CVV LOW BULK 8	69.44207	66.13563	67.87547	61.83418	293
4021	@CVV LOW CYL 1	68.44599	65.18338	66.9049	61.12031	293
4022	@CVV LOW CYL 2	68.00075	64.78801	66.48302	60.79537	293
4023	@CVV LOW CYL 3	66.69312	63.59158	65.22725	59.81788	293
4024	@CVV LOW CYL 4	66.07273	63.04445	64.6369	59.357	293
4025	@CVV LOW CYL 5	65.9214	62.90797	64.49266	59.23922	293
4026	@CVV LOW CYL 6	66.44371	63.36883	64.99029	59.66526	293
4027	@CVV LOW CYL 7	67.92216	64.697	66.39669	60.73553	293
4028	@CVV LOW CYL 8	68.43818	65.17147	66.89459	61.11738	293
4031	@CVV UPP CYL 1	67.97786	64.72021	66.44274	60.81429	293
4032	@CVV UPP CYL 2	67.55635	64.35422	66.0474	60.47655	293
4033	@CVV UPP CYL 3	66.53065	63.44612	65.07522	59.72217	293
4034	@CVV UPP CYL 4	65.25021	62.31337	63.8648	58.80631	293
4035	@CVV UPP CYL 5	65.1814	62.253	63.80003	58.77136	293
4036	@CVV UPP CYL 6	66.2726	63.22071	64.8323	59.57968	293
4037	@CVV UPP CYL 7	67.51223	64.31489	66.0041	60.50157	293
4038	@CVV UPP CYL 8	67.96468	64.70774	66.42951	60.81883	293
4041	@CVV UPP BULK 1	67.79621	64.53649	66.26244	60.73213	293
4042	@CVV UPP BULK 2	67.37196	64.16197	65.86162	60.39681	293
4043	@CVV UPP BULK 3	66.65557	63.53307	65.18611	59.8786	293
4044	@CVV UPP BULK 4	65.61392	62.60136	64.19616	59.1019	293
4045	@CVV UPP BULK 5	65.5673	62.56053	64.15215	59.07831	293
4046	@CVV UPP BULK 6	66.54063	63.43238	65.07759	59.82272	293
4047	@CVV UPP BULK 7	67.32363	64.11785	65.81472	60.3915	293
4048	@CVV UPP BULK 8	67.7842	64.52655	66.25122	60.7346	293
4050	CVV -Z Radiator low cyl.	65.79206	62.77831	64.36052	59.11702	293
4051	CVV -Z Rad. arithm. low	65.89136	62.8719	64.4584	59.19994	293
4052	CVV -Z Rad. arithm. upp	64.77187	61.89496	63.41531	58.46448	293
4053	CVV -Z Radiator upp cyl.	64.58605	61.73971	63.24441	58.34202	293
4055	CVV -Y Radiator	66.54283	63.45838	65.08646	59.72334	293
4057	CVV +Y Radiator	66.2896	63.23371	64.84655	59.57652	293
4070	Cryostat baffle pz	67.24783	64.02278	65.73062	60.32506	293
4071	Cryostat baffle my	66.81189	63.64517	65.32193	59.99246	293
4072	Cryostat baffle mz	65.81362	62.75328	64.37483	59.26224	293
4073	Cryostat baffle py	66.77898	63.61643	65.29075	59.98312	293
4075	Cryostat inner baffle	66.63676	63.44748	65.13511	59.85033	293
4079	Cryostat baffle top	66.66252	63.4949	65.17205	59.88277	293
4081	Pretension 1	66.85822	63.70868	65.36927	59.85563	293
4082	Pretension 2	66.46861	63.36256	65.00006	59.57046	293
4083	Pretension 3	65.22743	62.22685	63.80832	58.63976	293
4084	Pretension 4	64.59394	61.67176	63.20777	58.17193	293
4085	Pretension 5	64.45187	61.54351	63.07229	58.06152	293
4086	Pretension 6	64.95413	61.98108	63.54819	58.46984	293
4087	Pretension 7	66.37326	63.25889	64.89922	59.50019	293
4088	Pretension 8	66.83511	63.68362	65.34477	59.84216	293
4090	CVV LOU windows	67.22301	64.03846	65.723	60.21961	292.35748
4101	CVV MLI low bulk 1 low	176.80665	161.15329	169.45325	150.07532	293
4102	CVV MLI low bulk 2 low	168.08696	152.28273	160.34707	137.42399	293
4103	CVV MLI low bulk 3 low	159.37272	143.32325	151.22557	124.819	293
4104	CVV MLI low bulk 4 low	153.1403	137.25361	144.98058	117.65149	293



Thermal Report

Herschel

Node	LABEL	Orbit hot T [K]	Orbit cold T [K]	Orbit avg T [K]	Orbit Safe T [K]	Ground T [K]
4105	CVV MLI low bulk 5 low	151.84693	135.98249	143.689	116.29321	293
4106	CVV MLI low bulk 6 low	156.74853	140.74942	148.61732	122.40909	293
4107	CVV MLI low bulk 7 low	164.93971	149.26192	157.27254	135.02659	293
4108	CVV MLI low bulk 8 low	176.4038	160.73993	169.04432	149.72818	293
4111	CVV MLI low bulk 1 upp	170.0565	157.20191	164.55774	152.45781	293
4112	CVV MLI low bulk 2 upp	142.26688	131.78461	137.63649	125.5897	293
4113	CVV MLI low bulk 3 upp	122.23693	110.89862	116.50717	97.63716	293
4114	CVV MLI low bulk 4 upp	121.68311	110.18536	115.76619	95.50493	293
4115	CVV MLI low bulk 5 upp	120.24378	108.84761	114.35777	94.04346	293
4116	CVV MLI low bulk 6 upp	118.59857	107.49598	112.985	94.81084	293
4117	CVV MLI low bulk 7 upp	137.2437	126.62599	132.61599	122.11969	293
4118	CVV MLI low bulk 8 upp	169.59574	156.7701	164.1215	152.22738	293
4121	CVV MLI low cyl 1	165.41489	153.50328	160.51573	150.52706	293
4122	CVV MLI low cyl 2	140.07384	130.25826	135.93778	125.74708	293
4127	CVV MLI low cyl 7	133.46908	123.64272	129.37667	121.0203	293
4128	CVV MLI low cyl 8	164.99904	153.07517	160.09842	150.24524	293
4131	CVV MLI upp cyl 1	161.56425	149.7054	156.69722	147.17033	293
4132	CVV MLI upp cyl 2	136.43913	126.61593	132.33111	122.61603	293
4137	CVV MLI upp cyl 7	130.89267	121.01933	126.78834	118.79837	293
4138	CVV MLI upp cyl 8	161.20016	149.32935	156.33066	146.93044	293
4141	CVV MLI upp bulk 1 low	141.34772	128.45837	135.8559	126.60891	293
4142	CVV MLI upp bulk 2 low	123.005	111.86968	118.24782	109.91217	293
4143	CVV MLI upp bulk 3 low	77.08598	70.48411	74.25483	68.65174	293
4146	CVV MLI upp bulk 6 low	71.63106	65.03937	68.79622	63.91738	293
4147	CVV MLI upp bulk 7 low	120.84012	109.67476	116.06708	108.10721	293
4148	CVV MLI upp bulk 8 low	140.69648	127.83076	135.21838	126.1238	293
4151	CVV MLI upp bulk 1 upp	133.74413	120.53573	128.04532	118.81734	293
4152	CVV MLI upp bulk 2 upp	118.96665	107.54421	114.04415	105.79015	293
4153	CVV MLI upp bulk 3 upp	87.18435	78.87419	83.5901	77.36027	293
4156	CVV MLI upp bulk 6 upp	86.51556	78.23342	82.94322	76.97802	293
4157	CVV MLI upp bulk 7 upp	116.23375	105.11864	111.44232	103.55708	293
4158	CVV MLI upp bulk 8 upp	133.411	120.16136	127.68646	118.45871	293
4170	Cryost. baf. MLI pz	137.09572	124.23766	131.5976	122.53488	293
4171	Cryost. baf. MLI my	108.31296	98.30672	104.02082	96.63338	293
4173	Cryost. baf. MLI py	107.18626	97.1808	102.89668	95.71612	293
4179	Cryost. baf. MLI top	110.81534	100.74184	106.4719	98.88305	293
4180	Cryo-baf. SLI collar pz	130.04783	118.28017	125.01469	116.29991	292.99951
4181	Cryo-baf. SLI collar my	112.67576	102.63727	108.36612	100.59079	292.9993
4182	Cryo-baf. SLI collar mz	92.38069	84.11012	88.80483	82.38371	292.99981
4183	Cryo-baf. SLI collar py	111.75805	101.69917	107.43962	99.83049	292.99986
4201	LOU supp. plate LOA1 mx	130.15855	126.67751	128.61493	97.21301	293
4202	LOU supp. plate LOA2 mx	130.20209	126.71957	128.65779	97.22879	293
4203	LOU supp. plate LOA3 mx	130.21467	126.7317	128.67016	97.23359	293
4204	LOU supp. plate LOA4 mx	130.21462	126.73162	128.6701	97.23321	293
4205	LOU supp. plate LOA5 mx	130.21431	126.73138	128.66982	97.23342	293
4206	LOU supp. plate LOA6 mx	130.19908	126.71686	128.65492	97.22741	293
4207	LOU supp. plate LOA7 mx	130.14651	126.66664	128.60342	97.20777	293
4211	LOU supp. plate LOA1 px	130.17384	126.69228	128.62998	97.21827	293
4212	LOU supp. plate LOA2 px	130.20355	126.72106	128.65927	97.22938	293
4213	LOU supp. plate LOA3 px	130.21281	126.7299	128.66833	97.23254	293
4214	LOU supp. plate LOA4 px	130.20886	126.72594	128.66437	97.22962	293
4215	LOU supp. plate LOA5 px	130.21251	126.72962	128.66804	97.2324	293
4216	LOU supp. plate LOA6 px	130.20193	126.71956	128.6577	97.22866	293
4217	LOU supp. plate LOA7 px	130.15896	126.67848	128.61558	97.21214	293
4260	LOU MLI cap px inside	121.34191	116.99851	119.44419	95.64968	293

Node	LABEL	Orbit hot T [K]	Orbit cold T [K]	Orbit avg T [K]	Orbit Safe T [K]	Ground T [K]
4261	LOU MLI cap px outside	120.42318	110.46613	116.18866	107.58438	293
4263	LOU_supp_MLI_pY	135.47948	125.89447	131.45174	120.92788	293
4270	LOU Radiator low.	115.65943	112.74955	114.37538	91.89148	293
4271	LOU Radiator upp.	124.72952	121.49596	123.29851	95.34237	293
4279	LOU Rad. straps pX I/F	130.06246	126.58606	128.52095	97.18075	293
4280	LOU Rad. straps pX	129.03591	125.60382	127.5146	96.83108	293
4281	LOU Rad. supp. pZpX	126.10749	122.75461	124.62293	95.85854	293
4283	LOU Rad. supp. pZmX	119.57892	116.37802	118.16488	93.60203	293
4285	LOU Rad. supp. pZ	123.49092	120.22121	122.04414	94.90721	293
4287	LOU Rad. supp. mZpX	127.17998	123.82631	125.69435	96.18311	293
4289	LOU Rad. supp. mZmX	117.55019	114.52653	116.21482	92.65787	293
4301	LOU_harn_3132 @ LOU I/F	136.24752	131.54447	134.15542	105.61755	293
4302	LOU_harness_3132	148.27191	141.77158	145.36752	121.81068	293
4303	LOU_harness_3132	162.3352	154.3201	158.7164	138.20452	293
4304	LOU_harness_3132	181.99441	171.95756	177.3839	156.8802	293
4305	LOU_harness_Strut 32	218.05218	203.46038	211.22422	186.29001	293
4306	LOU_harn_Strut 32 @ SVM	255.75414	234.94917	245.83667	213.21224	293
4311	LOU_harn_3334 @ LOU I/F	135.052	130.43005	132.99009	104.91405	293
4312	LOU_harness_3334	143.64489	137.83453	141.03254	118.2611	293
4313	LOU_harness_3334	154.61084	147.74979	151.49104	132.01152	293
4314	LOU_harness_3334	171.86168	163.32486	167.90921	149.02403	293
4315	LOU_harness_Strut 33	205.28364	192.43582	199.19466	176.58339	293
4316	LOU_harn_Strut 33 @ SVM	244.03762	224.94253	234.91372	204.30932	293
4361	LOU Waveguid 1 @ LOU I/F	131.53455	125.65923	128.95475	105.2904	293
4362	LOU Waveguid 2	135.02446	127.3488	131.68031	115.34579	293
4363	LOU Waveguid 3	136.14004	128.36747	132.73067	120.31136	293
4364	LOU Waveguid 4	147.0467	139.24968	143.55465	132.05921	293
4365	LOU Waveguid 5	182.42527	172.00766	177.5964	161.86873	293
4366	LOU Waveguid 6 @ SVM I/F	274.08257	251.59002	263.33968	229.22696	293
4411	CVV MLI low bulk 1 int	86.9864	80.94493	84.35025	77.13239	293
4412	CVV MLI low bulk 2 int	77.42079	72.69055	75.23134	68.34002	293
4417	CVV MLI low bulk 7 int	76.83435	72.06748	74.66744	68.03289	293
4418	CVV MLI low bulk 8 int	87.48561	81.37697	84.82512	77.6262	293
4421	CVV MLI low cyl 1 int	84.27482	78.62789	81.83369	75.47557	293
4422	CVV MLI low cyl 2 int	75.80101	71.35499	73.8254	67.58323	293
4427	CVV MLI low cyl 7 int	74.82805	70.34022	72.82496	66.89731	293
4428	CVV MLI low cyl 8 int	84.67654	78.95809	82.20572	75.87082	293
4431	CVV MLI upp cyl 1 int	82.84821	77.22729	80.43966	74.28953	293
4432	CVV MLI upp cyl 2 int	74.85153	70.41408	72.87681	66.76327	293
4437	CVV MLI upp cyl 7 int	73.7408	69.30431	71.77436	66.02989	293
4438	CVV MLI upp cyl 8 int	82.73359	77.11688	80.32689	74.22823	293
4455	CVV -Y Rad. MLI	131.02073	121.99702	127.19492	116.7204	293
4456	CVV -Y Rad. MLI int	69.49148	65.28942	67.60855	61.53245	293
4457	CVV +Y Rad. MLI	143.06188	132.31402	138.59555	129.74402	293
4458	CVV +Y Rad. MLI int	71.64699	66.8516	69.4905	64.03027	293
4470	Cryost. baf. MLI pz int	79.00515	73.08335	76.3793	70.28099	293
4471	Cryost. baf. MLI my int	70.93308	66.45183	68.90309	63.29141	293
4473	Cryost. baf. MLI py int	70.49445	66.1297	68.50461	62.96503	293
4541	CVV TS2 gap	67.75074	64.49265	66.21755	60.6996	282.77526
4542	CVV TS2 gap	67.32777	64.12005	65.81835	60.36554	282.74497
4543	CVV TS2 gap	66.61344	63.49378	65.14522	59.8489	282.73281
4544	CVV TS2 gap	65.57609	62.56604	64.15943	59.0748	282.67612
4545	CVV TS2 gap	65.53061	62.52609	64.11643	59.05191	282.69785
4546	CVV TS2 gap	66.50141	63.39535	65.03929	59.79479	282.82005
4547	CVV TS2 gap	67.28208	64.07767	65.77364	60.36165	282.79327

Node	LABEL	Orbit hot T [K]	Orbit cold T [K]	Orbit avg T [K]	Orbit Safe T [K]	Ground T [K]
4548	CVV TS2 gap	67.73927	64.48299	66.20675	60.70227	282.76418
4901	H501	61.45436	58.67409	60.12854	55.7496	288.56307
4902	Tube_4902	60.28981	57.61616	59.00715	55.03941	237.64449
4903	V502 external	63.10578	60.27286	61.75929	57.10709	279.49882
4910	LHV_Support_1	66.6725	63.57338	65.20776	59.80452	292.69467
4911	V501_Support	66.308	63.23753	64.85585	59.55164	289.38284
4912	V503_Support	66.36283	63.28751	64.90841	59.58832	289.92
4913	Tube_4913	63.64458	60.79299	62.28349	57.77963	256.52404
4914	Tube_4914	63.64601	60.79434	62.28489	57.78081	256.5639
4915	Tube_Jct4913_14_16	63.64235	60.79088	62.28085	57.77424	257.45261
4916	Tube_4916	63.6343	60.78326	62.27179	57.75838	259.79324
4917	Tube_4917	62.32956	59.5469	60.99853	56.73702	247.71982
4918	Tube_4918	62.28514	59.50878	60.95689	56.70347	247.67383
4919	Tube_Jct4917_18_02	61.88829	59.13097	60.56844	56.37098	245.60132
4920	LHV_Support_2	66.0609	63.03425	64.62582	59.34935	292.88194
4921	V505_Support	65.98105	62.96218	64.54936	59.29413	292.36945
4922	V504_Support	65.90937	62.89584	64.47992	59.24955	291.25864
4923	Tube_4923	64.31981	61.4321	62.94185	58.24119	266.00123
4924	Tube_Jct4916_23_25	63.96582	61.09878	62.59646	57.98657	264.31645
4925	Tube_4925	63.69666	60.8493	62.33522	57.78131	266.45541
4926	Tube_Jct4925_37_38	64.19169	61.3131	62.81827	58.09929	276.66198
4927	Tube_4927	64.5928	61.70125	63.21581	58.33918	282.12849
4928	Tube_4928	64.748	61.83574	63.36016	58.51729	273.66181
4930	SV521_Support	66.06533	63.03812	64.63	59.35203	292.98802
4931	V506	66.06501	63.03785	64.62971	59.35182	292.9876
4932	P501	66.06516	63.03798	64.62985	59.35191	292.98779
4936	Tube_4936	63.48031	60.58852	62.10407	57.29366	292.46784
4937	Tube_4937	64.96915	62.03641	63.57479	58.60633	288.81048
4938	Tube_4938_1	63.75996	60.91542	62.39914	57.8114	273.30583
4939	Tube_4939	64.50135	61.61327	63.12222	58.3645	275.51905
4940	A_Frame	65.95565	62.94047	64.52602	59.26975	292.83547
4941	Support_mY_up	65.95523	62.94028	64.5257	59.26977	292.85246
4942	Support_mY_low	66.03626	63.01218	64.60238	59.33008	292.95601
4943	P502_Support_Plate	65.97009	62.9536	64.53984	59.28107	292.86841
4944	P502	65.96939	62.953	64.53919	59.2806	292.86587
4945	Support_pY	65.93116	62.91795	64.50252	59.24938	292.92131
4946	Tube_4946	65.35923	62.40139	63.95253	58.91647	281.52664
4947	Tube_4947	65.35931	62.40146	63.9526	58.91651	281.52801
4948	pY_Nozzle_Support	65.94386	62.93032	64.51496	59.26249	292.62992
4949	mY_Nozzle_Support	65.94391	62.93037	64.51501	59.26253	292.62901
4950	mZ_Nozzle_Support	65.94992	62.93565	64.52073	59.26602	292.81735
4961	V502 internal	59.61623	57.02026	58.37585	54.49337	233.59966
4962	H501 internal	59.82612	57.21425	58.57611	54.67117	231.11263
5000	GHe tank outlet	1.65003	1.63896	1.65003	1.59502	1.80024
5010	GHe Tank-PACS	1.65262	1.6414	1.65254	1.59763	1.81152
5011	GHe Tank-PACS	1.65912	1.64738	1.65879	1.60365	1.82663
5012	GHe Tank-PACS	1.66167	1.64977	1.66125	1.6062	1.87428
5013	GHe Tank-PACS	1.66527	1.65314	1.66472	1.60981	1.88164
5014	GHe PACS I/F 1	1.88705	1.88692	1.89191	1.82138	1.99891
5020	GHe PACS I/F 1	2.12405	2.12944	2.13134	2.02351	2.36742
5021	GHe PACS I/F 1	2.22664	2.23283	2.23416	2.10683	2.54823
5022	GHe PACS I/F 1	2.35897	2.36381	2.36583	2.20775	2.84119
5023	GHe PACS I/F 1/2	2.43911	2.44364	2.44575	2.27081	2.93638
5024	GHe PACS I/F 2	2.53039	2.53473	2.53692	2.34174	3.07003
5025	GHe PACS I/F 2	2.70782	2.71012	2.71356	2.47491	3.47965

Node	LABEL	Orbit hot T [K]	Orbit cold T [K]	Orbit avg T [K]	Orbit Safe T [K]	Ground T [K]
5026	GHe PACS I/F 2	2.77689	2.77732	2.7819	2.52427	3.68548
5027	GHe PACS I/F 2	2.86037	2.85703	2.86393	2.58085	4.0198
5028	GHe PACS I/F 2/3	2.91499	2.90955	2.91803	2.61824	4.219
5029	GHe PACS I/F 3	2.9885	2.98115	2.9913	2.6703	4.46455
5030	GHe PACS I/F 3	3.05285	3.04297	3.05505	2.71421	4.7876
5031	GHe PACS I/F 3	3.08057	3.06985	3.08297	2.73291	4.96402
5032	GHe PACS I/F 3	3.11714	3.10478	3.1191	2.75835	5.23202
5033	GHe PACS-SPIRE	3.15562	3.14436	3.15848	2.79266	5.43185
5034	GHe PACS-SPIRE	3.25814	3.25527	3.26607	2.89692	5.49881
5035	GHe SPIRE I/F 1	3.67999	3.68984	3.69616	3.28508	5.96627
5036	GHe SPIRE I/F 1	4.16802	4.18241	4.1881	3.71951	6.80813
5037	GHe SPIRE I/F 1	4.34298	4.35579	4.36335	3.86706	7.22912
5038	GHe SPIRE I/F 1	4.52806	4.53311	4.54506	4.01115	7.91312
5039	GHe SPIRE I/F 2	4.75875	4.77948	4.78513	4.24359	8.15685
5043	GHe HIFI I/F	5.42395	5.47788	5.47026	4.89465	8.27673
5044	GHe HIFI I/F	5.58768	5.64475	5.63685	5.04382	8.33869
5045	GHe HIFI I/F	5.67729	5.73668	5.72885	5.12558	8.37731
5046	GHe HIFI I/F	5.75798	5.81496	5.8088	5.19148	8.43461
5050	GHe L1-L2	5.79277	5.84876	5.84333	5.22025	8.47842
5051	GHe L1-L2	5.90348	5.97928	5.96595	5.35764	8.48303
5052	GHe L1-L2	6.34766	6.4611	6.43093	5.83551	8.50447
5053	GHe L1-L2	7.8834	8.01872	7.97834	7.27716	8.75616
5054	GHe L1-L2	11.86272	11.85379	11.88408	10.61329	11.29169
5060	GHe Lev.2 OB	12.66607	12.58163	12.64995	11.17637	16.29528
5061	GHe Lev.2 OB	12.95343	12.84449	12.92516	11.38484	19.11347
5062	GHe Lev.2 OB	13.01775	12.90342	12.9869	11.43793	20.06399
5063	GHe Lev.2 OB	12.99397	12.8812	12.96397	11.41303	20.22245
5070	GHe L2-L3	13.04851	12.94681	13.02648	11.41632	20.22535
5071	GHe PM JFET I/F	13.31341	13.24094	13.31179	11.4307	20.2579
5080	GHe PM JFET I/F	13.44787	13.38477	13.45356	11.43757	20.29491
5081	GHe PM JFET I/F	13.49191	13.43242	13.50109	11.43978	20.31493
5082	GHe PM JFET I/F	13.51734	13.45724	13.52658	11.44096	20.343
5083	GHe SM JFET I/F	13.53214	13.47897	13.54847	11.44355	20.35711
5084	GHe SM JFET I/F	13.55624	13.51148	13.58103	11.44747	20.36761
5085	GHe SM JFET I/F	13.5605	13.51976	13.58948	11.44841	20.37305
5086	GHe SM JFET I/F	13.56414	13.52302	13.59297	11.44879	20.38036
5090	GHe L3-TS1	13.55801	13.52033	13.59043	11.44895	20.38245
5091	GHe L3-TS1	13.59983	13.57236	13.64189	11.5264	20.3868
5092	GHe L3-TS1	23.89152	23.59065	23.77768	23.07446	25.26811
5110	GHe TS 1 / line pymz	33.13027	32.16693	32.68304	31.28179	61.33429
5111	GHe TS 1 / line pymz	34.11104	33.06377	33.62223	32.09281	73.10217
5112	GHe TS 1 / line pymz	34.6423	33.55408	34.1335	32.52276	80.40987
5113	GHe TS 1 / line pymz	34.51194	33.42842	34.00532	32.41068	81.73286
5119	GHe TS 1 / line pymz	34.67531	33.58563	34.16556	32.59134	81.88139
5120	GHe TS 1 / line mypz	33.10313	32.14151	32.65674	31.261	61.20359
5121	GHe TS 1 / line mypz	34.20821	33.15318	33.71574	32.16589	74.20176
5122	GHe TS 1 / line mypz	34.63204	33.54232	34.12266	32.49497	81.28716
5123	GHe TS 1 / line mypz	34.49617	33.41306	33.98978	32.3936	82.3501
5129	GHe TS 1 / line mypz	34.66001	33.57068	34.15046	32.57476	82.50585
5210	GHe TS 2 / line pymz	44.97215	43.20432	44.12592	41.88692	129.42073
5211	GHe TS 2 / line pymz	45.42423	43.6084	44.55496	42.21543	140.27898
5212	GHe TS 2 / line pymz	45.50744	43.68059	44.63283	42.27405	144.16434
5213	GHe TS 2 / line pymz	45.54464	43.7132	44.66782	42.30029	145.78535
5219	GHe TS 2 / line pymz	45.76037	43.91839	44.87655	42.5189	146.05169
5220	GHe TS 2 / line mypz	44.98654	43.21485	44.13852	41.89701	132.00362

Node	LABEL	Orbit hot T [K]	Orbit cold T [K]	Orbit avg T [K]	Orbit Safe T [K]	Ground T [K]
5221	GHe TS 2 / line mypz	45.41414	43.59526	44.54344	42.20622	143.83535
5222	GHe TS 2 / line mypz	45.50967	43.68102	44.63423	42.27465	146.1459
5223	GHe TS 2 / line mypz	45.54555	43.71351	44.66846	42.3006	146.58042
5229	GHe TS 2 / line mypz	45.76165	43.91905	44.87754	42.51952	146.84363
5310	GHe TS 3 / line pymz	54.50695	52.13444	53.37267	49.90337	202.26382
5311	GHe TS 3 / line pymz	54.74765	52.35262	53.60306	50.06783	211.3997
5312	GHe TS 3 / line pymz	54.85523	52.45021	53.70606	50.14005	216.13638
5313	GHe TS 3 / line pymz	54.9088	52.49856	53.75724	50.17605	218.33706
5320	GHe TS 3 / line mypz	54.52191	52.14762	53.38681	49.91365	202.33771
5321	GHe TS 3 / line mypz	54.78783	52.38798	53.641	50.09543	211.38711
5322	GHe TS 3 / line mypz	54.89725	52.48709	53.74571	50.16905	216.14247
5323	GHe TS 3 / line mypz	54.9262	52.51375	53.77364	50.18799	218.35757
5329	GHe TS 3 out	55.23751	52.81373	54.07773	50.49512	218.75676
5330	GHe V502 out	59.59135	57.00108	58.35356	54.48425	229.55614
5331	GHe H501 out	59.82559	57.21376	58.5756	54.67075	231.10908
5332	GHe ext.Tube 4902 out	60.28876	57.61524	59.00617	55.03857	237.60959
5333	GHe ext.Tube 4917 out	62.32492	59.5425	60.99398	56.73315	247.6831
5334	GHe ext.Tube 4918 out	62.28059	59.50446	60.95244	56.69967	247.63727
5335	GHe ext.Tube 4913/14 out	63.64224	60.79077	62.2812	57.77779	256.50266
5336	GHe ext.Tube 4916 out	63.63433	60.78328	62.27181	57.75842	259.73321
5337	GHe ext.Tube 4923 out	64.31826	61.43062	62.94032	58.24009	265.96127
5338	GHe ext.Tube 4928 out	64.74703	61.83482	63.3592	58.51666	273.64424
5339	GHe ext.Tube 4927 out	64.59316	61.70155	63.21614	58.33959	282.10914
5340	GHe ext.Tube 4925 out	63.69653	60.84915	62.33508	57.78126	266.44007
5341	GHe ext.Tube 4938 out	63.75983	60.91527	62.39899	57.81133	273.29016
5342	GHe ext.Tube 4939 out	64.49966	61.61168	63.12057	58.36324	275.42758
5343	GHe ext.Tube 4946 out	65.35731	62.39959	63.95063	58.91521	281.2827
5344	GHe ext.Tube 4947 out	65.35739	62.39966	63.9507	58.91525	281.28401
5900	Mass Flow Rate [mg/s]	2.33092	2.17677	2.26113	1.76352	25.79042
5901	Helium: Init Mass [kg]	337	337	337	337	337
5902	Helium: Act Mass [kg]	337	337	337	337	337
5903	Helium: Cons Mass [kg]	0	0	0	0	0
5950	Lifetime [days]	1437.21869	1532.28268	1478.65576	1869.13949	216.11896
5951	Heat to Tank [mW]	53.30519	49.66088	51.64704	40.02301	597.71007
6201	SVM SHIELD tip +Y	129.19753	117.26631	123.25291	105.07667	293
6202	SVM SHIELD tip -Y	132.0435	119.9558	126.05481	107.65054	293
6204	SVM SHIELD +Y	133.29914	120.4833	126.89961	107.45897	293
6205	SVM SHIELD -Y	136.52717	123.36875	129.9931	110.09586	293
6206	SVM SHIELD -Z	123.98533	113.8488	118.933	102.81633	293
6301	SVM SHIELD SLI tip +Y	111.20673	102.05629	107.10523	97.4865	293
6302	SVM SHIELD SLI tip -Y	115.16489	106.13293	111.11811	100.68086	293
6304	SVM SHIELD SLI +Y	115.51468	105.6763	110.8502	98.06639	293
6305	SVM SHIELD SLI -Y	122.26144	112.28271	117.5605	104.1284	293
6306	SVM SHIELD SLI -Z	91.53044	83.8174	87.69779	75.68227	293
6501	STRUT1_CVVSV	254.41669	253.24724	253.85729	216.5539	293
6502	STRUT1_CVVSV	191.64102	188.54786	190.17351	164.64728	293
6503	STRUT1_CVVSV	120.06287	116.40981	118.33259	103.63887	293
6511	STRUT2_CVVSV	224.39784	221.74045	223.11105	193.32439	293
6512	STRUT2_CVVSV	189.04337	184.15687	186.6931	161.70883	293
6513	STRUT2_CVVSV	152.72305	147.47904	150.2107	128.50033	293
6521	STRUT3_CVVSV	233.13234	229.15441	231.20562	200.0331	293
6522	STRUT3_CVVSV	201.60125	194.72992	198.29993	171.4224	293
6523	STRUT3_CVVSV	163.5586	156.49394	160.16664	136.8066	293
6531	STRUT4_CVVSV	255.2635	254.38019	254.82171	216.64567	293
6532	STRUT4_CVVSV	191.28668	189.13311	190.22198	163.75423	293

Node	LABEL	Orbit hot T [K]	Orbit cold T [K]	Orbit avg T [K]	Orbit Safe T [K]	Ground T [K]
6533	STRUT4_CVVSVM	118.89706	115.89148	117.44176	102.50608	293
6541	STRUT5_CVVSVM	241.34953	238.4777	239.95374	207.87587	293
6542	STRUT5_CVVSVM	185.83396	180.90653	183.4058	161.46272	293
6543	STRUT5_CVVSVM	131.40994	125.7018	128.68874	114.40755	293
6551	STRUT6_CVVSVM	229.77231	226.39423	228.06595	198.43559	293
6552	STRUT6_CVVSVM	176.05988	170.9206	173.50223	153.09503	293
6553	STRUT6_CVVSVM	125.70787	120.10781	123.02311	109.6245	293
6561	STRUT7_CVVSVM	249.27583	248.02322	248.60433	214.13704	293
6562	STRUT7_CVVSVM	201.85541	198.42679	200.02858	176.22627	293
6563	STRUT7_CVVSVM	174.77191	169.48538	171.97263	152.61651	293
6564	STRUT7_CVVSVM	157.28329	150.60456	153.76956	136.34531	293
6565	STRUT7_CVVSVM	143.7817	136.45192	139.95532	123.76887	293
6566	STRUT7_CVVSVM	130.51548	123.423	126.86348	112.40645	293
6567	STRUT7_CVVSVM	116.52704	110.10459	113.27142	100.83706	293
6568	STRUT7_CVVSVM	103.06389	97.42675	100.25214	89.65783	293
6569	STRUT7_CVVSVM	89.99222	85.08797	87.58823	78.59982	293
6570	STRUT7_CVVSVM	76.00908	72.03447	74.11247	66.90514	293
6571	STRUT8_CVVSVM	248.60793	247.5099	248.01384	213.67152	293
6572	STRUT8_CVVSVM	200.22022	197.17047	198.57701	175.04744	293
6573	STRUT8_CVVSVM	172.70277	167.82861	170.09398	151.02018	293
6574	STRUT8_CVVSVM	155.25081	148.85944	151.85255	134.56779	293
6575	STRUT8_CVVSVM	142.35332	135.00063	138.47024	122.05092	293
6576	STRUT8_CVVSVM	130.38159	122.88102	126.45509	111.19242	293
6577	STRUT8_CVVSVM	116.76436	109.87497	113.20367	99.89776	293
6578	STRUT8_CVVSVM	102.66029	96.7925	99.67366	88.55322	293
6579	STRUT8_CVVSVM	89.3428	84.37575	86.86727	77.64575	293
6580	STRUT8_CVVSVM	75.6535	71.68002	73.74363	66.49167	293
6581	STRUT9_CVVSVM	247.93528	246.95525	247.40113	213.15357	293
6582	STRUT9_CVVSVM	199.00707	196.2107	197.49114	173.87155	293
6583	STRUT9_CVVSVM	170.17306	165.59396	167.71086	148.43377	293
6584	STRUT9_CVVSVM	150.69288	144.45152	147.36687	129.71897	293
6585	STRUT9_CVVSVM	140.49342	133.36366	136.7057	119.73576	293
6586	STRUT9_CVVSVM	131.97338	124.5088	128.0279	111.70398	293
6587	STRUT9_CVVSVM	123.14452	116.05365	119.43201	104.31019	293
6588	STRUT9_CVVSVM	113.82415	107.44467	110.51808	96.82367	293
6589	STRUT9_CVVSVM	96.69295	91.35175	93.97272	82.9167	293
6590	STRUT9_CVVSVM	78.30766	74.16163	76.26937	68.20352	293
6591	STRUT10_CVVSVM	247.84024	246.95274	247.35357	213.18307	293
6592	STRUT10_CVVSVM	198.215	195.70436	196.84321	173.7346	293
6593	STRUT10_CVVSVM	169.57926	165.48512	167.35502	148.94141	293
6594	STRUT10_CVVSVM	151.43944	145.91011	148.45317	131.91761	293
6595	STRUT10_CVVSVM	138.6025	131.94789	135.03387	119.14992	293
6596	STRUT10_CVVSVM	127.72573	120.44835	123.84978	108.53758	293
6597	STRUT10_CVVSVM	116.20363	109.15675	112.48936	98.50858	293
6598	STRUT10_CVVSVM	103.12341	96.8582	99.86923	87.86143	293
6599	STRUT10_CVVSVM	89.48511	84.25356	86.82607	77.01651	293
6600	STRUT10_CVVSVM	75.4167	71.33197	73.42495	65.96682	293
6601	STRUT11_CVVSVM	247.42292	246.53918	246.94203	212.87603	293
6602	STRUT11_CVVSVM	197.66444	195.06461	196.26335	173.15725	293
6603	STRUT11_CVVSVM	168.44012	163.92596	166.03958	147.5785	293
6604	STRUT11_CVVSVM	149.24093	142.58541	145.75391	129.10943	293
6605	STRUT11_CVVSVM	139.41428	132.1632	135.60896	119.76974	293
6606	STRUT11_CVVSVM	132.50347	124.84858	128.49539	113.1231	293
6607	STRUT11_CVVSVM	126.97768	119.31976	123.0015	108.26164	293
6608	STRUT11_CVVSVM	121.52801	114.09269	117.71344	103.81185	293

Node	LABEL	Orbit hot T [K]	Orbit cold T [K]	Orbit avg T [K]	Orbit Safe T [K]	Ground T [K]
6609	STRUT11_CVVSVM	101.59511	95.59492	98.54776	87.37399	293
6610	STRUT11_CVVSVM	80.21238	75.8178	78.03395	69.87682	293
6611	STRUT12_CVVSVM	247.46918	246.62141	247.00413	212.84715	293
6612	STRUT12_CVVSVM	197.15646	194.68763	195.81101	172.65063	293
6613	STRUT12_CVVSVM	167.34521	163.15309	165.08282	146.58407	293
6614	STRUT12_CVVSVM	147.43481	141.44518	144.23691	127.55327	293
6615	STRUT12_CVVSVM	136.68613	129.83897	133.03775	117.08599	293
6616	STRUT12_CVVSVM	128.37396	121.01353	124.46742	109.00862	293
6617	STRUT12_CVVSVM	120.76	113.44554	116.90975	102.27512	293
6618	STRUT12_CVVSVM	112.52468	105.68471	108.96966	95.61957	293
6619	STRUT12_CVVSVM	95.55517	89.94526	92.69374	81.95364	293
6620	STRUT12_CVVSVM	77.71454	73.48047	75.63584	67.75178	293
6621	STRUT13_CVVSVM	247.76856	246.81818	247.25178	213.14536	293
6622	STRUT13_CVVSVM	199.09477	196.38832	197.63292	174.23785	293
6623	STRUT13_CVVSVM	170.5773	166.06752	168.16645	149.24428	293
6624	STRUT13_CVVSVM	151.574	145.28957	148.25376	131.1213	293
6625	STRUT13_CVVSVM	142.17326	135.06353	138.41524	121.88068	293
6626	STRUT13_CVVSVM	134.90448	127.37967	130.94213	114.85881	293
6627	STRUT13_CVVSVM	127.92042	120.63275	124.11611	108.93665	293
6628	STRUT13_CVVSVM	120.51783	113.75684	117.02678	103.01789	293
6629	STRUT13_CVVSVM	101.70635	96.02459	98.80728	87.3224	293
6630	STRUT13_CVVSVM	80.54768	76.23174	78.40375	70.03171	293
6631	STRUT14_CVVSVM	247.54005	246.57906	247.0154	212.90259	293
6632	STRUT14_CVVSVM	199.37748	196.65002	197.89755	174.06893	293
6633	STRUT14_CVVSVM	170.55389	166.05081	168.12995	148.39751	293
6634	STRUT14_CVVSVM	150.40339	144.16627	147.07435	128.73037	293
6635	STRUT14_CVVSVM	142.00486	134.94455	138.24306	120.4064	293
6636	STRUT14_CVVSVM	135.08822	127.67372	131.15175	113.72198	293
6637	STRUT14_CVVSVM	128.08671	120.83698	124.26014	107.58024	293
6638	STRUT14_CVVSVM	120.40816	113.70406	116.89401	101.30635	293
6639	STRUT14_CVVSVM	102.28865	96.53982	99.31629	86.54954	293
6640	STRUT14_CVVSVM	81.0269	76.64562	78.83204	69.86475	293
6641	STRUT15_CVVSVM	247.90434	246.88587	247.35291	213.16885	293
6642	STRUT15_CVVSVM	199.77085	196.91928	198.23327	174.45016	293
6643	STRUT15_CVVSVM	171.24712	166.61821	168.76943	149.13831	293
6644	STRUT15_CVVSVM	151.46914	145.23181	148.15677	130.02854	293
6645	STRUT15_CVVSVM	142.40756	135.39054	138.69312	121.26609	293
6646	STRUT15_CVVSVM	134.41169	127.30589	130.67072	114.02867	293
6647	STRUT15_CVVSVM	125.82555	119.09094	122.30567	106.82824	293
6648	STRUT15_CVVSVM	117.85346	111.71103	114.66227	100.20246	293
6649	STRUT15_CVVSVM	100.25965	94.95778	97.54762	85.72527	293
6650	STRUT15_CVVSVM	80.26411	76.09655	78.19859	69.70397	293
6651	STRUT16_CVVSVM	248.42449	247.2845	247.8101	213.43302	293
6652	STRUT16_CVVSVM	199.77029	196.53964	198.04118	174.2617	293
6653	STRUT16_CVVSVM	171.19297	165.89905	168.38469	148.88929	293
6654	STRUT16_CVVSVM	151.63423	144.42298	147.84527	130.02473	293
6655	STRUT16_CVVSVM	140.6767	132.94539	136.63541	119.95406	293
6656	STRUT16_CVVSVM	130.4398	122.83658	126.50113	111.2264	293
6657	STRUT16_CVVSVM	120.08269	112.97784	116.439	102.74064	293
6658	STRUT16_CVVSVM	111.7768	104.96805	108.3098	95.53467	293
6659	STRUT16_CVVSVM	95.23655	89.66679	92.45028	82.14841	293
6660	STRUT16_CVVSVM	77.88922	73.68072	75.84633	68.15002	293
6661	STRUT17_CVVSVM	248.61286	247.3941	247.97376	213.82327	293
6662	STRUT17_CVVSVM	201.48855	198.15063	199.75294	176.17876	293
6663	STRUT17_CVVSVM	173.43268	168.19524	170.74348	151.73749	293

Node	LABEL	Orbit hot T [K]	Orbit cold T [K]	Orbit avg T [K]	Orbit Safe T [K]	Ground T [K]
6664	STRUT17_CVVSV	153.21454	146.49044	149.81552	133.13615	293
6665	STRUT17_CVVSV	143.98325	136.84365	140.41567	125.0101	293
6666	STRUT17_CVVSV	134.8131	127.66331	131.29755	117.31273	293
6667	STRUT17_CVVSV	126.71477	119.79291	123.36104	110.47694	293
6668	STRUT17_CVVSV	119.72617	113.0012	116.48306	104.10355	293
6669	STRUT17_CVVSV	103.33999	97.24138	100.42866	89.79079	293
6670	STRUT17_CVVSV	82.50055	77.77976	80.26012	72.10797	293
6671	STRUT18_CVVSV	215.24743	212.14465	213.70508	185.32022	293
6672	STRUT18_CVVSV	166.38555	161.93521	164.21557	145.34261	293
6673	STRUT18_CVVSV	122.18311	117.04592	119.73967	107.53977	293
6681	STRUT19_CVVSV	227.78756	224.50569	226.16714	196.85897	293
6682	STRUT19_CVVSV	194.73876	188.97004	191.91214	167.21726	293
6683	STRUT19_CVVSV	158.16121	152.16587	155.25068	133.81891	293
6691	STRUT20_CVVSV	242.28189	234.64734	238.58769	206.66028	293
6692	STRUT20_CVVSV	216.29863	203.83952	210.32694	182.22306	293
6693	STRUT20_CVVSV	177.17776	164.70273	171.21309	146.50858	293
6701	STRUT21_CVVSV	217.4203	213.34462	215.44902	186.97791	293
6702	STRUT21_CVVSV	192.67143	186.26223	189.59667	164.11341	293
6703	STRUT21_CVVSV	167.25712	160.62772	164.08848	140.22511	293
6711	STRUT22_CVVSV	254.62889	253.5399	254.10543	216.64917	293
6712	STRUT22_CVVSV	192.5695	189.80735	191.24564	165.04202	293
6713	STRUT22_CVVSV	120.68678	117.09921	118.98103	103.95072	293
6721	STRUT23_CVVSV	254.66737	253.56892	254.13972	216.6811	293
6722	STRUT23_CVVSV	192.58797	189.82995	191.26952	165.07837	293
6723	STRUT23_CVVSV	120.52339	117.00422	118.8552	103.88015	293
6731	STRUT24_CVVSV	254.70286	253.58966	254.16951	216.70409	293
6732	STRUT24_CVVSV	192.73443	189.92253	191.39074	165.16494	293
6733	STRUT24_CVVSV	120.83273	117.20009	119.11036	104.05937	293
8401	MLI FRAME_pZ	134.44082	122.09164	129.15538	120.19785	293
8402	MLI FRAME_CORNER_mY	127.28084	116.05097	122.48098	113.92158	293
8403	MLI FRAME_mY	94.14925	85.92779	90.64596	84.17685	293
8404	FRAME_CORNER_mZ	73.37236	67.50738	70.73409	65.8841	293
8405	MLI FRAME_pY	93.45002	85.20127	89.94071	83.6732	293
8406	MLI FRAME_CORNER_pY	125.49217	114.28521	120.70285	112.41059	293
8411	MLI TUBE_to_CVV_mYpZ	132.79252	120.85738	127.70408	119.00239	293
8412	MLI TUBE_to_CVV_mYmZ	117.89299	107.74774	113.55466	105.70413	293
8413	TUBE_to_CVV_mZmY	67.10223	62.68839	65.08066	60.46124	293
8414	TUBE_to_CVV_mZpY	67.08501	62.55804	65.0193	60.45198	293
8415	MLI TUBE_to_CVV_pYmZ	115.93186	105.80469	111.59614	104.13847	293
8416	MLI TUBE_to_CVV_pYpZ	131.79564	119.85761	126.70536	118.14745	293
8608	Tel. harness 02	225.26301	211.04529	218.50782	189.75665	293
8609	Tel. harness 03	148.35087	140.47516	144.62098	129.04206	293
8610	Tel. harness 1	105.58	100.67694	103.2732	94.01219	293
8611	Tel. harness 2	89.50475	85.70069	87.71071	80.91413	293
8612	Tel. harness 3	80.87715	77.47794	79.28604	73.56186	293
8613	Tel. harness 4	76.13904	72.80864	74.59189	69.39964	293
8614	Tel. harness 5	73.93514	70.43714	72.32322	67.38815	293
8615	Tel. harness 6	73.99875	69.83143	72.09907	67.19409	293
8616	Tel. harness 7	76.14408	70.83456	73.73904	68.61208	293
8620	Tel. CBs on TMS	78.49519	72.06192	75.58448	70.1411	293
9001	CVV CBs 1	68.31828	65.07549	66.78663	61.02619	293
9002	CVV CBs 2	68.0525	64.87714	66.55258	60.83962	293
9003	CVV CBs 3	66.92775	63.7783	65.43795	59.96193	293
9004	CVV CBs 4	66.08221	63.06014	64.64774	59.367	293
9005	CVV CBs 5	65.67521	62.69364	64.26023	59.03965	293



Thermal Report

Herschel

Node	LABEL	Orbit hot T [K]	Orbit cold T [K]	Orbit avg T [K]	Orbit Safe T [K]	Ground T [K]
9006	CVV CBs 6	66.43822	63.36823	64.98694	59.66671	293
9007	CVV CBs 7	67.97794	64.77317	66.46204	60.77485	293
9008	CVV CBs 8	68.47364	65.22289	66.93765	61.1452	293
9011	IP_08_09_10_11_12	88.58921	85.89878	87.3086	80.01562	293
9012	IH_02_05	119.74274	117.39424	118.6192	105.06129	293
9013	IS_04_05	78.32713	74.70941	76.564	69.8658	293
9014	IS_03_07_08_09	93.79119	89.53139	91.69647	84.11	293
9015	IS_02_11_13	91.46988	87.02687	89.2516	80.2998	293
9016	IS_10	85.72836	82.22628	83.98393	76.89391	293
9017	IP_03_04_14	116.16979	112.04602	114.18465	101.21016	293
9018	IP_13	105.72921	102.96242	104.41037	91.10542	293
9021	IP Rail2728_Strut24	196.65595	189.87527	193.40454	167.27964	293
9022	IH Rail2900_Strut29	192.18919	187.52633	189.94409	163.31552	293
9023	IS Rail3334_Strut38	139.18762	130.38944	134.66306	117.66975	293
9024	IS Rail3800_Strut38	150.79266	141.17866	145.95875	129.24036	293
9025	IS Rail3900_Strut38	145.32137	135.16059	140.14353	122.38981	293
9026	IS Rail4041_Strut40	135.66906	127.92437	131.64932	115.1895	293
9027	IP Rail2122_Strut22	201.8658	195.59577	198.82066	173.03693	293
9028	IP Rail2400_Strut24	195.26959	189.17646	192.34264	165.54761	293
9032	IH_01_03_04	102.35108	99.16311	100.83397	90.44658	293
9033	IS_06	94.04792	90.14209	92.08725	84.34155	293
9034	ICE_13_ICE14_Strut36	135.89641	128.41488	131.99819	114.28769	293
9035	IS Rail3900_Strut39	135.1769	126.63808	130.74648	113.84581	293
9036	CCH_ICA_10_ICB_10	73.17659	70.28859	71.77148	66.05507	293
9037	IP_05_06_15	101.82901	99.36579	100.65346	89.15226	293
9038	IP_01_02_07	105.47445	102.2072	103.92027	93.68669	293
9042	IH Rail3132_Strut30	207.77118	200.29132	204.18076	176.36991	293
9043	IS Rail3800_Strut38	135.72264	127.47783	131.46835	115.16147	293
9045	IS_01_12	94.07238	90.33375	92.21516	84.29623	293
9046	CCH Rail4200_Strut41	132.51058	124.50887	128.30196	110.19999	293
9047	IP Rail2400_Strut24	194.97442	188.63344	191.93008	164.84365	293
9048	IP Rail2526_Strut24	194.72376	188.26273	191.62414	165.51268	293
9055	IS Rail4041_Strut40	146.88814	139.18206	142.95751	125.95897	293
9056	CCH Rail4200_Strut42	135.02639	128.43696	131.55033	113.74467	293
9057	ICE_11_ICE12_Strut44	139.6091	132.2793	135.96588	119.85835	293
9065	ICA_12_ICB12_Strut41	139.24324	132.33117	135.62385	117.45908	293
9066	CCH_ICE_10_ICE_20	73.64845	70.40413	72.07496	66.22708	293
9076	CCH Rail4344_Strut43	137.0455	126.9723	131.84149	113.37009	293
9086	ICA_11_Strut41	137.30571	130.22001	133.54352	114.57443	293
9096	ICB_11_Strut42	138.56836	131.23823	134.73084	116.16293	293
9101	PACS int. harn. 11	6.70954	6.6623	6.69833	5.75971	11.64662
9102	PACS int. harn. 11	9.72019	9.65503	9.70575	8.43746	14.13512
9103	PACS int. harn. 11	11.84235	11.76076	11.82517	10.3794	16.2641
9104	PACS int. harn. 11	12.72486	12.63566	12.70636	11.22302	17.23445
9105	PACS int. harn. 11	17.31782	16.97323	17.17131	15.73986	32.22099
9106	PACS int. harn. 11	23.99853	23.34034	23.69863	22.2536	50.73025
9107	PACS int. harn. 11	31.54825	30.57765	31.0968	29.50825	70.74217
9108	PACS int. harn. 11	34.69973	33.60274	34.18726	32.54849	79.22751
9109	PACS int. harn. 11	41.71387	40.1696	40.98675	38.45991	125.17809
9110	PACS int. harn. 11	53.55021	51.21456	52.44785	48.40701	200.1669
9111	PACS int. harn. 11	63.69397	60.72808	62.29318	57.0535	263.95529
9121	PACS int. harn. 13	12.07128	12.04662	12.0656	5.72894	11.61894
9122	PACS int. harn. 13	15.72136	15.68087	15.7124	8.4094	14.06523
9123	PACS int. harn. 13	15.15741	15.09361	15.14374	10.35763	16.15617
9124	PACS int. harn. 13	12.71382	12.62628	12.69613	11.20237	17.10878

Node	LABEL	Orbit hot T [K]	Orbit cold T [K]	Orbit avg T [K]	Orbit Safe T [K]	Ground T [K]
9125	PACS int. harn. 13	13.26055	13.15192	13.23241	11.38354	19.14037
9126	PACS int. harn. 13	13.57712	13.4499	13.54008	11.63511	20.31734
9127	PACS int. harn. 13	26.29396	25.63976	25.99557	23.44274	48.2432
9128	PACS int. harn. 13	33.68698	32.67847	33.21815	31.70743	67.13013
9129	PACS int. harn. 13	41.17117	39.69862	40.47911	37.88615	117.19084
9130	PACS int. harn. 13	53.4635	51.1638	52.37827	48.15743	196.21958
9131	PACS int. harn. 13	63.82148	60.86239	62.42356	57.05929	262.7868
9141	PACS int. harn. 15	9.42333	9.38875	9.41451	5.79048	11.91905
9142	PACS int. harn. 15	12.66093	12.60531	12.64742	8.4898	14.73102
9143	PACS int. harn. 15	13.4421	13.36125	13.42264	10.44716	17.10372
9144	PACS int. harn. 15	12.84591	12.74731	12.82275	11.29752	18.17841
9145	PACS int. harn. 15	22.57848	22.36459	22.49019	14.74224	27.90067
9146	PACS int. harn. 15	28.76753	28.35155	28.5806	19.97404	41.02755
9147	PACS int. harn. 15	27.66994	26.97783	27.3531	24.12558	51.28775
9148	PACS int. harn. 15	33.78986	32.77391	33.31741	31.77609	68.12347
9149	PACS int. harn. 15	41.19092	39.7212	40.49979	37.85825	117.87791
9150	PACS int. harn. 15	53.29668	51.02161	52.22213	47.9858	196.65156
9151	PACS int. harn. 15	63.443	60.52405	62.06261	56.75303	262.93647
9201	PACS int. harn. res.	3.26999	3.23098	3.25704	2.83038	9.88019
9202	PACS int. harn. res.	12.9743	12.86392	12.94533	11.40273	19.29497
9206	PACS int. harn. res.	25.13222	24.52142	24.8543	22.81085	46.01268
9208	PACS int. harn. res.	33.74638	32.7343	33.27579	31.75294	67.52715
9212	PACS int. harn. res.	12.70841	12.62044	12.69051	11.20852	17.14028
9213	PACS int. harn. res.	12.94883	12.84025	12.92072	11.38168	19.13946
9214	PACS int. harn. res.	12.9633	12.85361	12.93467	11.39197	19.25063
9215	PACS int. harn. res.	13.3583	13.22509	13.31839	11.73071	20.6786
9216	PACS int. harn. res.	25.04575	24.42936	24.76532	22.86377	45.74269
9218	PACS int. harn. res.	33.5885	32.58944	33.1242	31.63818	65.7691
9226	PACS int. harn. res.	23.4633	22.83862	23.17925	21.78933	48.21812
9228	PACS int. harn. res.	34.62276	33.53366	34.11406	32.49105	78.07429
9301	SPIRE int. harn. 3	14.31452	14.18674	14.28429	12.19447	23.83997
9302	SPIRE int. harn. 3	15.24141	15.02718	15.16385	13.34004	28.05507
9303	SPIRE int. harn. 3	16.10514	15.81349	15.98548	14.38914	31.69982
9304	SPIRE int. harn. 3	16.51532	16.18812	16.37661	14.88434	33.36944
9305	SPIRE int. harn. 3	23.24545	22.54559	22.92326	21.27994	56.68516
9306	SPIRE int. harn. 3	32.62171	31.46921	32.07831	30.08755	88.12906
9307	SPIRE int. harn. 3	41.69363	40.10372	40.93661	38.47531	125.84508
9308	SPIRE int. harn. 3	45.85327	44.00457	44.97198	42.19546	152.68072
9309	SPIRE int. harn. 3	49.61102	47.53333	48.62173	45.3508	179.15875
9310	SPIRE int. harn. 3	56.60389	54.11479	55.42053	51.26872	227.86266
9311	SPIRE int. harn. 3	63.0378	60.18418	61.6826	56.75721	272.16641
9321	SPIRE int. harn. 11	7.95272	7.90256	7.94232	6.45527	14.84857
9322	SPIRE int. harn. 11	10.71483	10.63554	10.69396	8.85504	17.29204
9323	SPIRE int. harn. 11	12.47758	12.37233	12.44871	10.67681	19.44132
9324	SPIRE int. harn. 11	13.07354	12.95537	13.04079	11.48061	20.43411
9325	SPIRE int. harn. 11	20.06006	19.60908	19.86024	17.77556	40.71595
9326	SPIRE int. harn. 11	28.68871	27.84187	28.29569	26.26714	66.039
9327	SPIRE int. harn. 11	33.70528	32.64632	33.21023	31.12317	82.56789
9328	SPIRE int. harn. 11	35.61627	34.45372	35.07175	33.29196	90.13105
9329	SPIRE int. harn. 11	41.82106	40.29419	41.10004	38.53869	132.87297
9330	SPIRE int. harn. 11	52.41027	50.21559	51.37032	47.51775	204.01361
9331	SPIRE int. harn. 11	61.52582	58.78673	60.22626	55.40028	265.09232
9341	SPIRE int. harn. res.	4.8686	4.84223	4.86958	4.23991	13.17922
9342	SPIRE int. harn. res.	13.05165	12.93448	13.01939	11.4691	20.35696
9346	SPIRE int. harn. res.	29.10509	28.20957	28.68863	26.94435	69.26599

Node	LABEL	Orbit hot T [K]	Orbit cold T [K]	Orbit avg T [K]	Orbit Safe T [K]	Ground T [K]
9348	SPIRE int. harn. res.	35.54653	34.38942	35.00463	33.24297	89.30352
9361	PM JFET int. hn. res.	13.72185	13.65145	13.72323	11.44854	20.89433
9364	PM JFET int. hn. res.	14.55474	14.34411	14.47472	12.97012	26.08908
9365	PM JFET int. hn. res.	21.63822	21.02442	21.35831	19.80578	49.74457
9366	PM JFET int. hn. res.	30.97452	29.91776	30.47799	28.64823	78.23265
9367	PM JFET int. hn. res.	41.76399	40.18717	41.01336	38.66693	119.68317
9368	PM JFET int. hn. res.	46.835	44.91198	45.91812	43.15607	156.03576
9374	PM JFET int. hn. res.	14.68621	14.46825	14.60238	13.10078	26.60553
9375	PM JFET int. hn. res.	22.19518	21.55724	21.9032	20.32985	51.84766
9376	PM JFET int. hn. res.	31.94959	30.85668	31.43496	29.55358	81.55055
9377	PM JFET int. hn. res.	41.95302	40.38068	41.20367	38.86128	120.22843
9378	PM JFET int. hn. res.	46.77933	44.87952	45.87248	43.13957	155.47193
9381	SM JFET int. hn. res.	13.60788	13.55897	13.62986	11.45235	20.51052
9384	SM JFET int. hn. res.	14.77921	14.55726	14.69411	13.1855	26.97607
9385	SM JFET int. hn. res.	21.64983	21.03957	21.37219	19.75029	51.03501
9386	SM JFET int. hn. res.	30.78923	29.74602	30.30034	28.3407	80.58731
9387	SM JFET int. hn. res.	41.96995	40.37765	41.21173	38.74728	124.43831
9388	SM JFET int. hn. res.	47.17329	45.23641	46.24958	43.37452	163.22214
9401	HIFI int. harn. 1	13.59561	13.49256	13.56865	11.33886	19.97949
9402	HIFI int. harn. 1	13.86979	13.77541	13.84662	11.30223	18.98909
9403	HIFI int. harn. 1	13.39417	13.30372	13.37382	11.26549	17.94607
9404	HIFI int. harn. 1	12.7556	12.6647	12.7363	11.24707	17.402
9405	HIFI int. harn. 1	18.30101	17.91181	18.13242	16.55413	36.55813
9406	HIFI int. harn. 1	26.07835	25.34048	25.73944	23.94682	59.51277
9407	HIFI int. harn. 1	32.67088	31.63637	32.1885	30.38254	80.16053
9408	HIFI int. harn. 1	35.49414	34.33625	34.95233	33.14417	89.23485
9409	HIFI int. harn. 1	42.22169	40.64834	41.48046	38.84077	132.1928
9410	HIFI int. harn. 1	53.68463	51.36904	52.59155	48.51162	203.62023
9411	HIFI int. harn. 1	63.54865	60.63658	62.17318	56.95359	264.96446
9421	HIFI int. harn. 2	18.04414	17.96412	18.02256	11.34092	19.99174
9422	HIFI int. harn. 2	20.17956	20.1122	20.16246	11.30774	19.02406
9423	HIFI int. harn. 2	17.45843	17.38639	17.44146	11.27446	18.00736
9424	HIFI int. harn. 2	12.78383	12.6921	12.76414	11.25779	17.47812
9425	HIFI int. harn. 2	18.49571	18.10805	18.32779	16.55569	36.86984
9426	HIFI int. harn. 2	26.24762	25.50661	25.90722	23.99069	60.08846
9427	HIFI int. harn. 2	32.80989	31.77472	32.32716	30.40605	80.6587
9428	HIFI int. harn. 2	35.52928	34.36819	34.98594	33.16584	89.71232
9429	HIFI int. harn. 2	42.36286	40.78113	41.61779	38.87732	132.62269
9430	HIFI int. harn. 2	53.85965	51.54042	52.7649	48.56044	203.9873
9431	HIFI int. harn. 2	63.6326	60.72019	62.25698	56.97496	265.10713
9441	HIFI int. harn. 3	13.5179	13.41431	13.49082	11.33882	19.97923
9442	HIFI int. harn. 3	13.75379	13.65869	13.73047	11.30212	18.98835
9443	HIFI int. harn. 3	13.32388	13.23302	13.30346	11.2653	17.9448
9444	HIFI int. harn. 3	12.75523	12.66435	12.73595	11.24685	17.40044
9445	HIFI int. harn. 3	18.30044	17.91134	18.1319	16.55317	36.54675
9446	HIFI int. harn. 3	26.07679	25.33911	25.73797	23.94502	59.49036
9447	HIFI int. harn. 3	32.66811	31.63389	32.18587	30.38006	80.12283
9448	HIFI int. harn. 3	35.49063	34.33306	34.94897	33.14141	89.189
9449	HIFI int. harn. 3	42.21996	40.64687	41.47886	38.8388	132.16047
9450	HIFI int. harn. 3	53.68445	51.36902	52.59145	48.51062	203.60419
9451	HIFI int. harn. 3	63.54886	60.63684	62.17341	56.95329	264.95976
9461	HIFI int. harn. 4	17.61654	17.53478	17.59454	11.34081	19.99113
9462	HIFI int. harn. 4	19.59336	19.52432	19.57599	11.30745	19.02234
9463	HIFI int. harn. 4	17.06592	16.99244	17.04867	11.27399	18.00436
9464	HIFI int. harn. 4	12.78243	12.69074	12.76276	11.25723	17.47442



Thermal Report

Herschel

Node	LABEL	Orbit hot T [K]	Orbit cold T [K]	Orbit avg T [K]	Orbit Safe T [K]	Ground T [K]
9465	HIFI int. harn. 4	18.49885	18.11129	18.33097	16.55538	36.86612
9466	HIFI int. harn. 4	26.24787	25.50706	25.90757	23.98869	60.07666
9467	HIFI int. harn. 4	32.81183	31.77675	32.32914	30.4058	80.6556
9468	HIFI int. harn. 4	35.52945	34.36835	34.98611	33.16602	89.71145
9469	HIFI int. harn. 4	42.36468	40.78277	41.61953	38.87849	132.62908
9470	HIFI int. harn. 4	53.86194	51.54256	52.76712	48.56204	203.9964
9471	HIFI int. harn. 4	63.63359	60.72113	62.25795	56.97567	265.1111
9481	HIFI int. harn. 5	24.33617	24.27825	24.32058	11.33469	19.95462
9482	HIFI int. harn. 5	28.48409	28.43779	28.47217	11.29105	18.91811
9483	HIFI int. harn. 5	23.26878	23.21678	23.25665	11.24725	17.82177
9484	HIFI int. harn. 5	12.75203	12.66283	12.73355	11.22528	17.24763
9485	HIFI int. harn. 5	18.9885	18.6155	18.82675	16.51769	35.74717
9486	HIFI int. harn. 5	26.26283	25.53882	25.93046	23.81491	58.13525
9487	HIFI int. harn. 5	33.02142	32.00473	32.54733	30.33012	79.16228
9488	HIFI int. harn. 5	35.45567	34.30281	34.91624	33.11185	88.42945
9489	HIFI int. harn. 5	42.24221	40.70521	41.51772	38.72946	131.11799
9490	HIFI int. harn. 5	53.74125	51.45901	52.66363	48.33899	202.4216
9491	HIFI int. harn. 5	63.60341	60.70527	62.23441	56.87484	264.45784
9501	HIFI int. coax tube	13.69875	13.53831	13.64431	12.10309	24.87169
9502	HIFI int. coax tube	15.47303	15.20607	15.36468	13.85608	33.60501
9503	HIFI int. coax tube	16.98887	16.63883	16.83939	15.31734	38.91276
9504	HIFI int. coax tube	32.7427	31.68448	32.25068	30.08238	100.78502
9505	HIFI int. coax tube	42.48244	40.97663	41.77397	38.98831	141.50696
9506	HIFI int. coax tube	51.31475	49.26742	50.34921	46.69044	186.25626
9507	HIFI int. coax tube	55.92696	53.58342	54.8207	50.67398	222.33024
9508	HIFI int. coax tube	62.27953	59.52594	60.97889	56.14082	271.98159
9509	HIFI int. coax tube	64.47624	61.56539	63.10084	58.0033	283.06743
9510	HIFI int. coax tube	65.7454	62.72358	64.31684	59.04186	288.4613
9551	HIFI int. coax core	16.59981	16.35755	16.50366	14.98964	44.06634
9552	HIFI int. coax core	18.93774	18.59394	18.79235	17.15709	68.19399
9553	HIFI int. coax core	21.47129	20.99992	21.26401	19.47096	92.38379
9554	HIFI int. coax core	25.5871	24.84647	25.2499	23.03591	125.6064
9555	HIFI int. coax core	30.96127	29.71555	30.3831	27.34883	160.66927
9556	HIFI int. coax core	38.0678	36.17385	37.16958	33.09406	201.31633
9557	HIFI int. coax core	42.57266	40.23734	41.48031	36.64694	226.06473
9558	HIFI int. coax core	48.93725	46.32629	47.70867	42.43283	259.89937
9559	HIFI int. coax core	53.98876	51.17139	52.65808	47.25557	275.62165
9560	HIFI int. coax core	60.15496	57.09883	58.70528	53.18176	286.2686
9700	HOT depl. harness on ISF	19.49618	18.7354	19.14052	18.02677	54.30319
9801	Styc. Br. on TS1/strap 3	34.57545	33.49106	34.069	32.45528	77.3765
9802	Styc. Br. on TS1/strap 4	35.35567	34.2114	34.82033	33.04181	87.16371
9803	Styc. Br. on TS1/strap 5	34.49607	33.41296	33.98968	32.39352	82.35106
9804	Styc. Br. on TS1/strap 6	34.51184	33.42832	34.00522	32.4106	81.73409
9805	Styc. Br. on TS1/strap 7	35.3801	34.23873	34.84578	33.11437	86.71402
9806	Styc. Br. on TS1/strap 8	34.15088	33.10089	33.66078	32.12595	73.41859
9807	Styc. Br. on TS1/strap 1	33.63682	32.6352	33.17124	31.67031	65.9508
9808	Styc. Br. on TS1/strap 2	33.52776	32.53438	33.06618	31.59201	64.93441
9921	Cover Act. harn.	77.81443	74.83932	76.40568	70.97438	293
9922	Cover Act. harn.	84.87491	81.92031	83.46433	77.88005	293
9923	Cover Act. harn.	130.49225	123.51825	127.07901	113.31817	292.99998
9924	Cover Act. harn.	153.68284	146.45806	150.2259	135.4966	292.99984
18401	FRAME_pZ	88.19426	79.3591	84.26011	76.78365	293
18402	FRAME_CORNER_mY	82.86384	75.14732	79.38381	73.18467	293
18403	FRAME_mY	78.40325	71.58258	75.24624	69.13329	293
18405	FRAME_pY	78.39907	71.51395	75.21484	69.16511	293

Node	LABEL	Orbit hot T [K]	Orbit cold T [K]	Orbit avg T [K]	Orbit Safe T [K]	Ground T [K]
18406	FRAME_CORNER_pY	82.81734	75.10486	79.33926	73.15399	293
18411	TUBE_to_CVV_mYpZ	76.82928	70.80138	74.09053	68.02047	293
18412	TUBE_to_CVV_mYmZ	75.94451	70.04489	73.26643	67.31965	293
18415	TUBE_to_CVV_pYmZ	75.84872	69.94828	73.17335	67.26337	293
18416	TUBE_to_CVV_pYpZ	76.79221	70.76776	74.05478	67.9984	293
18421	TUBE_to_FRAME_I/F_mYpZ	82.71286	75.00543	79.23327	73.03731	293
18422	TUBE_to_FRAME_I/F_mYmZ	82.26694	74.67628	78.83843	72.73738	293
18423	TUBE_to_FRAME_I/F_mZmY	78.53311	72.06245	75.60735	70.16768	293
18424	TUBE_to_FRAME_I/F_mZpY	78.78424	72.04405	75.7556	70.36539	293
18425	TUBE_to_FRAME_I/F_pYmZ	82.2367	74.64809	78.80973	72.72192	293
18426	TUBE_to_FRAME_I/F_pYpZ	82.69487	74.99056	79.21668	73.02739	293
22100	Harn. Rail 2100 low	78.83619	73.66881	76.32396	67.24014	293
22101	Harn. Rail 2100 upp	68.81773	65.50925	67.25506	61.5249	293
22122	Harn. Rail 2122	68.02326	64.78526	66.49091	60.80351	293
22300	Harn. Rail 2300	68.71437	65.3416	67.11623	61.20009	293
22400	Harn. Rail 2400	69.53146	66.19798	67.95566	61.75491	293
22526	Harn. Rail 2526	68.75188	65.45594	67.19411	61.31784	293
22728	Harn. Rail 2728	69.04673	65.74343	67.48598	61.54467	293
22900	Harn. Rail 2900	69.57103	66.25134	68.0023	61.80315	293
23132	Harn. supp. tube LOU +z	143.2122	134.96354	139.63276	125.46721	293
23334	Harn. supp. tube LOU -z	135.61225	128.72395	132.58311	118.16497	293
23800	Harn. Rail 3800	66.65819	63.54175	65.175	59.74659	293
23900	Harn. Rail 3900	66.02849	62.98742	64.58278	59.26565	293
24041	Harn. Rail 4041	65.96492	62.94978	64.53325	59.25784	293
24132	Harn. Rail 3132	68.81165	65.52428	67.25771	61.30051	293
24200	Harn. Rail 4200	66.09609	63.07039	64.66656	59.42646	293
24334	Harn. Rail 3334	66.8036	63.68438	65.32849	59.88819	293
24344	Harn. Rail 4344	66.35275	63.28216	64.90175	59.60159	293
65011	STRUT1_CVVSVM_MLI	210.2378	204.36833	207.61264	179.67873	293
65012	STRUT1_CVVSVM_MLI	205.71211	199.48204	202.82662	174.23542	293
65013	STRUT1_CVVSVM_MLI	207.03878	200.22053	203.76141	173.63806	293
65014	STRUT1_CVVSVM_MLI	214.44912	208.97797	211.87923	181.02512	293
65015	STRUT1_CVVSVM_MLI	180.93104	172.66253	177.29629	159.08692	293
65016	STRUT1_CVVSVM_MLI	179.34539	170.94932	175.50548	155.44657	293
65017	STRUT1_CVVSVM_MLI	178.39683	166.91453	173.00859	152.38175	293
65018	STRUT1_CVVSVM_MLI	178.38854	167.56561	173.51338	155.50398	293
65019	STRUT1_CVVSVM_MLI	164.41028	153.02185	159.66241	149.33951	293
65020	STRUT1_CVVSVM_MLI	162.67959	150.94139	157.53862	145.10055	293
65021	STRUT1_CVVSVM_MLI	166.83191	153.56673	160.73365	144.67807	293
65022	STRUT1_CVVSVM_MLI	166.39897	154.17969	161.08878	148.70037	293
65111	STRUT2_CVVSVM_MLI	188.0538	179.75214	184.32951	162.81759	293
65112	STRUT2_CVVSVM_MLI	189.75269	183.79138	187.01916	162.26008	293
65113	STRUT2_CVVSVM_MLI	191.78875	183.31464	187.64298	161.08424	293
65114	STRUT2_CVVSVM_MLI	191.57861	182.16164	187.14024	163.3706	293
65115	STRUT2_CVVSVM_MLI	175.63443	164.76225	170.861	154.62975	293
65116	STRUT2_CVVSVM_MLI	164.98152	155.29895	160.61716	143.70715	293
65117	STRUT2_CVVSVM_MLI	174.96428	163.00223	169.30833	148.33961	293
65118	STRUT2_CVVSVM_MLI	178.53739	166.5741	173.04088	154.05045	293
65119	STRUT2_CVVSVM_MLI	167.39021	155.92076	162.52637	149.75919	293
65120	STRUT2_CVVSVM_MLI	154.29215	143.86429	149.81166	137.29334	293
65121	STRUT2_CVVSVM_MLI	166.56562	153.77449	160.67357	142.94755	293
65122	STRUT2_CVVSVM_MLI	171.51019	158.94308	165.89642	150.06772	293
65211	STRUT3_CVVSVM_MLI	202.76535	196.15493	199.73193	172.79438	293
65212	STRUT3_CVVSVM_MLI	190.7307	183.18438	187.12666	160.22762	293
65213	STRUT3_CVVSVM_MLI	196.55596	187.83125	192.27803	163.90849	293

Node	LABEL	Orbit hot T [K]	Orbit cold T [K]	Orbit avg T [K]	Orbit Safe T [K]	Ground T [K]
65214	STRUT3_CVVSVM_MLI	213.40635	207.19534	210.40209	180.49803	293
65215	STRUT3_CVVSVM_MLI	176.17037	165.44483	171.41383	154.29616	293
65216	STRUT3_CVVSVM_MLI	170.78156	159.85228	165.63783	145.23334	293
65217	STRUT3_CVVSVM_MLI	177.41237	165.1029	171.47057	148.49491	293
65218	STRUT3_CVVSVM_MLI	179.40299	167.72486	174.02784	154.53279	293
65219	STRUT3_CVVSVM_MLI	161.45696	150.46489	156.73273	143.56845	293
65220	STRUT3_CVVSVM_MLI	153.4742	142.43681	148.41634	131.65746	293
65221	STRUT3_CVVSVM_MLI	164.58761	151.56151	158.37812	138.11493	293
65222	STRUT3_CVVSVM_MLI	168.69608	156.70265	163.42354	148.72389	293
65311	STRUT4_CVVSVM_MLI	214.63266	210.23821	212.51565	179.46247	293
65312	STRUT4_CVVSVM_MLI	224.01256	220.7118	222.39558	187.10851	293
65313	STRUT4_CVVSVM_MLI	222.9079	218.88295	220.86145	184.91002	293
65314	STRUT4_CVVSVM_MLI	215.29176	210.28447	212.82211	179.20264	293
65315	STRUT4_CVVSVM_MLI	163.77112	155.27424	159.80966	140.96248	293
65316	STRUT4_CVVSVM_MLI	158.17606	150.68861	154.62482	134.29265	293
65317	STRUT4_CVVSVM_MLI	171.08726	160.60908	165.97747	143.02237	293
65318	STRUT4_CVVSVM_MLI	174.41917	163.77818	169.37422	148.27435	293
65319	STRUT4_CVVSVM_MLI	146.01852	135.64505	141.45128	129.71111	293
65320	STRUT4_CVVSVM_MLI	130.96618	122.01878	126.98147	115.25293	293
65321	STRUT4_CVVSVM_MLI	153.31783	141.08953	147.54447	130.67024	293
65322	STRUT4_CVVSVM_MLI	158.76235	146.27773	152.96568	136.99275	293
65411	STRUT5_CVVSVM_MLI	191.11929	185.07269	188.22979	161.70232	293
65412	STRUT5_CVVSVM_MLI	192.83379	185.19381	188.94533	159.82935	293
65413	STRUT5_CVVSVM_MLI	196.78754	188.14474	192.42358	162.98817	293
65414	STRUT5_CVVSVM_MLI	198.80212	191.29203	195.20277	167.85127	293
65415	STRUT5_CVVSVM_MLI	165.98087	156.37873	161.46099	142.78132	293
65416	STRUT5_CVVSVM_MLI	170.24294	158.76158	164.57797	141.71224	293
65417	STRUT5_CVVSVM_MLI	171.19612	159.12702	165.20786	141.66672	293
65418	STRUT5_CVVSVM_MLI	173.4319	162.25635	168.15018	148.2748	293
65419	STRUT5_CVVSVM_MLI	144.78424	135.22866	140.6197	128.85458	293
65420	STRUT5_CVVSVM_MLI	130.40349	122.15081	126.6604	114.39128	293
65421	STRUT5_CVVSVM_MLI	136.30554	126.61706	131.7412	116.96635	293
65422	STRUT5_CVVSVM_MLI	162.8577	151.75308	157.87885	143.00962	293
65511	STRUT6_CVVSVM_MLI	200.24309	192.72881	196.4584	167.14278	293
65512	STRUT6_CVVSVM_MLI	202.7953	197.93548	200.31816	170.23142	293
65513	STRUT6_CVVSVM_MLI	208.38759	203.11056	205.68548	175.19475	293
65514	STRUT6_CVVSVM_MLI	198.59522	190.61407	194.5494	164.89088	293
65611	STRUT7_CVVSVM_MLI	197.66148	193.2341	195.3392	166.18996	293
65612	STRUT7_CVVSVM_MLI	191.63603	187.0243	189.12459	159.75712	293
65613	STRUT7_CVVSVM_MLI	195.93421	189.87777	192.74128	163.09252	293
65614	STRUT7_CVVSVM_MLI	207.79115	203.11687	205.35571	175.29863	293
65711	STRUT8_CVVSVM_MLI	191.55148	186.93782	189.05337	159.82499	293
65712	STRUT8_CVVSVM_MLI	192.86948	189.59821	191.08791	161.78792	293
65713	STRUT8_CVVSVM_MLI	204.22771	200.77705	202.36925	172.03127	293
65714	STRUT8_CVVSVM_MLI	194.19022	188.56164	191.17712	161.64682	293
65811	STRUT9_CVVSVM_MLI	192.84923	189.72034	191.14296	161.74445	293
65812	STRUT9_CVVSVM_MLI	188.10221	184.35139	186.05903	156.84112	293
65813	STRUT9_CVVSVM_MLI	191.82357	186.72126	189.05071	159.38618	293
65814	STRUT9_CVVSVM_MLI	204.69653	201.20005	202.81741	172.47087	293
65911	STRUT10_CVVSVM_MLI	188.43961	184.68022	186.39263	157.30407	293
65912	STRUT10_CVVSVM_MLI	192.01268	189.3968	190.5642	161.49034	293
65913	STRUT10_CVVSVM_MLI	203.67815	200.77621	202.10057	172.04873	293
65914	STRUT10_CVVSVM_MLI	191.35181	186.45587	188.688	159.15007	293
66011	STRUT11_CVVSVM_MLI	193.98479	191.45143	192.60528	163.41898	293
66012	STRUT11_CVVSVM_MLI	186.92976	183.43822	185.02316	156.03875	293

Node	LABEL	Orbit hot T [K]	Orbit cold T [K]	Orbit avg T [K]	Orbit Safe T [K]	Ground T [K]
66013	STRUT11_CVVSVM_MLI	190.09186	185.40038	187.55533	158.0438	293
66014	STRUT11_CVVSVM_MLI	203.34854	200.26139	201.68664	171.86963	293
66111	STRUT12_CVVSVM_MLI	186.88557	183.42349	184.99005	155.93094	293
66112	STRUT12_CVVSVM_MLI	191.81568	189.30514	190.4214	161.29347	293
66113	STRUT12_CVVSVM_MLI	203.27217	200.34449	201.67945	171.47296	293
66114	STRUT12_CVVSVM_MLI	189.94241	185.31001	187.43371	157.85069	293
66211	STRUT13_CVVSVM_MLI	195.70022	193.15826	194.31388	164.86631	293
66212	STRUT13_CVVSVM_MLI	188.22054	184.47254	186.18278	157.10898	293
66213	STRUT13_CVVSVM_MLI	191.02338	186.15498	188.38097	158.83185	293
66214	STRUT13_CVVSVM_MLI	203.00194	199.9675	201.35478	171.16565	293
66311	STRUT14_CVVSVM_MLI	187.77969	184.10441	185.77368	156.56033	293
66312	STRUT14_CVVSVM_MLI	195.55328	192.72277	194.01108	164.41595	293
66313	STRUT14_CVVSVM_MLI	202.77955	199.40783	200.9612	170.76069	293
66314	STRUT14_CVVSVM_MLI	191.09037	186.17196	188.42008	158.77845	293
66411	STRUT15_CVVSVM_MLI	192.22398	189.1932	190.55741	161.29135	293
66412	STRUT15_CVVSVM_MLI	190.19556	185.91626	187.89219	158.6836	293
66413	STRUT15_CVVSVM_MLI	192.76207	187.42851	189.86838	160.32766	293
66414	STRUT15_CVVSVM_MLI	202.28095	198.95785	200.48516	170.23869	293
66511	STRUT16_CVVSVM_MLI	191.64213	187.55176	189.40409	159.92793	293
66512	STRUT16_CVVSVM_MLI	194.05039	190.2749	192.03708	162.73744	293
66513	STRUT16_CVVSVM_MLI	204.7907	200.85211	202.70265	172.53127	293
66514	STRUT16_CVVSVM_MLI	195.26082	189.8135	192.37037	162.6298	293
66611	STRUT17_CVVSVM_MLI	195.26259	191.48331	193.26203	164.06191	293
66612	STRUT17_CVVSVM_MLI	194.10253	188.81108	191.33494	162.81651	293
66613	STRUT17_CVVSVM_MLI	196.08033	189.92583	192.88462	163.82694	293
66614	STRUT17_CVVSVM_MLI	204.99902	201.13183	202.96123	172.84739	293
66711	STRUT18_CVVSVM_MLI	188.85949	182.97099	185.87637	157.79205	293
66712	STRUT18_CVVSVM_MLI	197.78567	193.16375	195.50331	167.71973	293
66713	STRUT18_CVVSVM_MLI	205.66602	201.18762	203.42195	174.85426	293
66714	STRUT18_CVVSVM_MLI	194.27695	187.76787	190.94758	162.46813	293
66811	STRUT19_CVVSVM_MLI	176.48496	169.95338	173.30609	147.92881	293
66812	STRUT19_CVVSVM_MLI	185.67623	177.49287	181.8063	157.92111	293
66813	STRUT19_CVVSVM_MLI	188.81803	179.54188	184.24429	157.53372	293
66814	STRUT19_CVVSVM_MLI	188.11462	180.83887	184.43666	155.98742	293
66815	STRUT19_CVVSVM_MLI	152.82364	144.52308	148.94943	130.50562	293
66816	STRUT19_CVVSVM_MLI	170.30445	159.45046	165.28261	146.52217	293
66817	STRUT19_CVVSVM_MLI	174.38197	162.24448	168.52951	146.36891	293
66818	STRUT19_CVVSVM_MLI	159.16696	149.38998	154.35634	132.42063	293
66819	STRUT19_CVVSVM_MLI	137.23147	128.01955	133.1883	120.54489	293
66820	STRUT19_CVVSVM_MLI	158.27934	147.29314	153.35304	138.37729	293
66821	STRUT19_CVVSVM_MLI	165.48491	152.40813	159.29974	140.01822	293
66822	STRUT19_CVVSVM_MLI	126.52591	118.10305	122.66963	108.28635	293
66911	STRUT20_CVVSVM_MLI	202.776	193.38965	198.38355	170.86272	293
66912	STRUT20_CVVSVM_MLI	223.08757	214.57192	219.06775	188.84553	293
66913	STRUT20_CVVSVM_MLI	216.22481	206.54506	211.52086	180.85297	293
66914	STRUT20_CVVSVM_MLI	199.94819	189.54888	194.93551	166.18469	293
66915	STRUT20_CVVSVM_MLI	179.08653	165.66761	172.97983	152.77045	293
66916	STRUT20_CVVSVM_MLI	183.26118	169.84163	177.24081	158.21382	293
66917	STRUT20_CVVSVM_MLI	177.13536	162.23892	170.15263	149.25781	293
66918	STRUT20_CVVSVM_MLI	179.02709	164.59887	172.19164	148.41788	293
66919	STRUT20_CVVSVM_MLI	159.29779	146.9485	153.76005	137.70691	293
66920	STRUT20_CVVSVM_MLI	166.85702	154.32642	161.39017	147.40145	293
66921	STRUT20_CVVSVM_MLI	170.46361	156.2986	163.86282	144.72646	293
66922	STRUT20_CVVSVM_MLI	164.18019	150.31075	157.58832	136.73952	293
67011	STRUT21_CVVSVM_MLI	179.50912	171.17651	175.77429	155.27393	293

Node	LABEL	Orbit hot T [K]	Orbit cold T [K]	Orbit avg T [K]	Orbit Safe T [K]	Ground T [K]
67012	STRUT21_CVVSVM_MLI	187.3889	177.41176	182.86817	162.26819	293
67013	STRUT21_CVVSVM_MLI	187.18559	176.53555	182.09406	158.16437	293
67014	STRUT21_CVVSVM_MLI	188.61682	180.50607	184.71958	158.96466	293
67015	STRUT21_CVVSVM_MLI	168.08106	157.80226	163.557	147.40786	293
67016	STRUT21_CVVSVM_MLI	179.35402	167.57521	174.103	156.82191	293
67017	STRUT21_CVVSVM_MLI	178.69868	166.07326	172.77794	152.0092	293
67018	STRUT21_CVVSVM_MLI	168.85254	157.62738	163.5933	143.69333	293
67019	STRUT21_CVVSVM_MLI	160.46435	149.76212	155.88843	142.76219	293
67020	STRUT21_CVVSVM_MLI	172.49911	160.616	167.32811	152.82309	293
67021	STRUT21_CVVSVM_MLI	174.03579	160.93935	168.03979	150.29206	293
67022	STRUT21_CVVSVM_MLI	153.99387	143.37675	149.28158	134.29661	293
67111	STRUT22_CVVSVM_MLI	206.77025	200.64114	203.99842	176.25051	293
67112	STRUT22_CVVSVM_MLI	213.844	208.61071	211.47253	181.94772	293
67113	STRUT22_CVVSVM_MLI	211.03498	204.88105	208.07016	177.15862	293
67114	STRUT22_CVVSVM_MLI	205.90995	199.39884	202.80245	173.01335	293
67115	STRUT22_CVVSVM_MLI	177.42618	167.28487	172.97545	156.20081	293
67116	STRUT22_CVVSVM_MLI	178.15245	168.06301	173.76446	157.3699	293
67117	STRUT22_CVVSVM_MLI	179.2956	168.08416	174.09314	154.11668	293
67118	STRUT22_CVVSVM_MLI	176.58854	165.69655	171.51879	151.45481	293
67119	STRUT22_CVVSVM_MLI	162.722	151.37516	157.87497	146.72749	293
67120	STRUT22_CVVSVM_MLI	164.20892	152.79692	159.42991	148.93009	293
67121	STRUT22_CVVSVM_MLI	167.25654	154.35398	161.45222	146.93199	293
67122	STRUT22_CVVSVM_MLI	163.65906	151.04552	157.90708	142.9331	293
67211	STRUT23_CVVSVM_MLI	209.69841	204.06277	207.17782	178.98915	293
67212	STRUT23_CVVSVM_MLI	208.14625	201.57187	205.13338	177.08014	293
67213	STRUT23_CVVSVM_MLI	207.92545	201.07339	204.64873	174.72623	293
67214	STRUT23_CVVSVM_MLI	213.86379	208.66906	211.39494	179.96856	293
67215	STRUT23_CVVSVM_MLI	176.84049	166.96947	172.57386	156.48102	293
67216	STRUT23_CVVSVM_MLI	180.68793	169.97472	175.91865	158.3695	293
67217	STRUT23_CVVSVM_MLI	180.02615	168.63596	174.7205	154.45023	293
67218	STRUT23_CVVSVM_MLI	175.64002	165.22137	170.89482	152.17607	293
67219	STRUT23_CVVSVM_MLI	162.55355	151.29306	157.85038	147.65408	293
67220	STRUT23_CVVSVM_MLI	167.56895	155.47626	162.35093	150.29422	293
67221	STRUT23_CVVSVM_MLI	168.6988	155.45576	162.68525	147.48102	293
67222	STRUT23_CVVSVM_MLI	162.13984	150.13509	156.87081	144.34742	293
67311	STRUT24_CVVSVM_MLI	208.36196	201.9311	205.46579	178.01166	293
67312	STRUT24_CVVSVM_MLI	212.77239	207.78923	210.48939	180.55349	293
67313	STRUT24_CVVSVM_MLI	211.00062	204.84608	208.03254	177.02804	293
67314	STRUT24_CVVSVM_MLI	207.61402	200.79962	204.40534	175.27168	293
67315	STRUT24_CVVSVM_MLI	180.56576	170.11444	175.99629	159.35934	293
67316	STRUT24_CVVSVM_MLI	174.77955	165.02656	170.50912	153.74796	293
67317	STRUT24_CVVSVM_MLI	178.97708	167.77365	173.76589	153.60467	293
67318	STRUT24_CVVSVM_MLI	179.82775	168.70212	174.72302	155.4389	293
67319	STRUT24_CVVSVM_MLI	166.20374	154.53141	161.28191	150.3659	293
67320	STRUT24_CVVSVM_MLI	160.40513	149.19159	155.67011	145.1073	293
67321	STRUT24_CVVSVM_MLI	167.13021	154.22347	161.32514	146.77832	293
67322	STRUT24_CVVSVM_MLI	168.07769	155.24224	162.33998	148.24424	293
EPLM:PACS						
711	Top Optic Housing	3.26779	3.22825	3.25455	2.82934	9.94621
712	Spectrometer Housing	3.26825	3.22926	3.2553	2.82903	9.87769
713	Collimator Housing	3.25997	3.22133	3.24715	2.82386	9.83343
714	Photometer Optic Hous.	3.04843	3.01887	3.03985	2.68028	8.29593
721	2K Feed-Through Red D	1.79416	1.78096	1.7931	1.69554	2.65119
722	2K Feed-Through Blue D	1.99682	1.98155	1.9948	1.78527	3.4695

Node	LABEL	Orbit hot T [K]	Orbit cold T [K]	Orbit avg T [K]	Orbit Safe T [K]	Ground T [K]
723	2K StSt I/F Blue Det.	1.67491	1.66383	1.67477	1.60961	1.90056
724	2K_StSt I/F Red Det.	1.67032	1.65915	1.67017	1.60996	1.90279
731	Grating Assy	3.27244	3.23392	3.25966	2.82386	9.83343
741	Red Detector *	1.87594	1.86209	1.87435	1.75476	2.96142
742	Red Detector CRE	3.27491	3.23627	3.26211	2.81499	9.79666
743	CFRP-Strut Red Det.	2.57209	2.54567	2.56483	2.29189	7.05665
744	Harness Red Det. Int	2.58084	2.55442	2.57357	2.28801	7.39195
751	Blue Detector *	2.08545	2.06983	2.08304	1.83666	3.69351
752	Blue Detector CRE	3.27743	3.23878	3.26462	2.81605	9.80024
753	CFRP-Strut Blue Det.	2.67684	2.64954	2.66917	2.33284	7.29693
754	Harness Blue Det. Int	2.68535	2.65809	2.6777	2.32903	7.52192
761	Photometer Cooler Pump	1.67364	1.6628	1.67361	1.59928	1.83283
762	Photometer Cooler Evap	1.6566	1.6455	1.65658	1.59744	1.8258
763	Photometer Buffer *	1.70087	1.68966	1.70071	1.61124	1.99097
771	CFRP-Strut (OB) 1	9.33227	9.24129	9.30731	8.05008	16.16239
772	CFRP-Strut (OB) 2	9.27072	9.18365	9.24794	8.01338	15.03332
773	CFRP-Strut (OB) 3	9.33331	9.24214	9.30825	8.05105	16.18806
781	Level 1,1 I/F	2.69957	2.68329	2.69695	2.42883	6.10302
782	Level 1,2 I/F	3.03506	3.01349	3.03009	2.68139	7.45561
783	Level 1,3 I/F	3.18961	3.16299	3.18333	2.79047	8.11977
EPLM:SPIRE						
800	L1 Strap IF1 @ SOB	4.74801	4.72607	4.75081	4.14998	11.90531
801	PH_JFET_ENCLOSURE	13.72145	13.65112	13.72287	11.44794	20.89011
802	SP_JFET_ENCLOSURE	13.60765	13.55878	13.62965	11.45207	20.5084
803	FPU_OPTICAL_BENCH	4.8049	4.77917	4.80616	4.18707	13.15062
804	RF_FILTER_BOXES	4.86724	4.84089	4.86822	4.23887	13.17698
805	BSM	4.81666	4.79092	4.81784	4.18707	13.15062
806	SMECm	4.82809	4.80242	4.82926	4.18707	13.15062
807	PH_CALIB	4.81684	4.7911	4.81801	4.18707	13.15062
808	SPEC_CALIB	4.8049	4.77917	4.80616	4.18707	13.15062
809	PH_DETECTOR_ENCLOSURE	1.69282	1.68164	1.69292	1.6283	2.23667
810	SP_DETECTOR_ENCLOSURE	1.67588	1.66486	1.67594	1.61564	2.02723
811	L0 Enclosure Flexible S	1.67314	1.66212	1.67319	1.61351	1.99889
812	L0 Pump Flexible Strap	1.70359	1.69273	1.70362	1.6069	1.8936
813	L0 Evap Flexible Strap	1.6595	1.6484	1.65952	1.59933	1.83995
814	L0 Enclosure External S	1.66997	1.65898	1.67002	1.61112	1.96592
815	L0 Pump External Strap	1.69258	1.68179	1.69261	1.60462	1.87169
816	L0 Evaporator External	1.65423	1.64316	1.65424	1.59696	1.81694
817	COOLER_PUMP	1.72884	1.71811	1.72888	1.76299	3.55128
818	COOLER_SHUNT	1.66084	1.64973	1.66085	1.6005	1.85235
819	COOLER_EVAP	0.28	0.28	0.28	1.66045	2.62172
820	COOLER_EVAP_HS	1.6609	1.6498	1.66092	1.60045	1.85151
821	COOLER_PUMP_HS	1.70788	1.69704	1.70792	1.608	1.9046
822	PH_DETECTORS	0.28152	0.2815	0.28152	1.66044	2.62164
823	SP DETECTORS	0.28382	0.28377	0.28382	1.66028	2.61869
830	L1 Strap IF2 @ SOB	4.74801	4.72608	4.75081	4.14998	11.9054
831	PH_L3 IF	13.55005	13.48517	13.55521	11.44186	20.48079
832	SP_L3 IF	13.57499	13.52982	13.59996	11.44941	20.41527
EPLM:HIFI						
910	HIFI_FPU_Main_structure	12.9633	12.85129	12.93314	11.36079	20.55157
911	Calibration_source_assem	12.96728	12.85531	12.93712	11.36079	20.55157
912	Focal_Plane_Chopper	12.96648	12.85451	12.93632	11.36079	20.55157
913	Diplexer_Rooftop_Transla	12.9633	12.85129	12.93314	11.36079	20.55157

Node	LABEL	Orbit hot T [K]	Orbit cold T [K]	Orbit avg T [K]	Orbit Safe T [K]	Ground T [K]
914	Second_stage_amplifier	12.98236	12.87056	12.95225	11.36079	20.55157
919	L2-boundary	12.95866	12.84709	12.92879	11.36477	20.34051
920	Mixer_Sub_Assembly	12.94007	12.8288	12.9102	11.32716	20.46493
921	First_stage_amplifier	12.956	12.8449	12.92616	11.32716	20.46493
922	EMC-filtering	12.94676	12.83557	12.9169	11.32716	20.46493
925	Magnet_current_dissipati	10.14225	10.08174	10.13378	8.94119	15.77036
930	Console_level1_decks	5.91672	5.95967	5.95913	5.30743	8.94227
935	Magnet_current_dissipati	4.51609	4.54483	4.54639	4.06657	6.76427
939	L1_boundary	5.8875	5.93159	5.93049	5.28415	8.8846
940	Console_level0_decks	1.97945	1.96962	1.98112	1.85184	2.69697
941	Mixer_Unit	1.98431	1.9745	1.98597	1.85184	2.69697
942	Heater	1.97945	1.96962	1.98112	1.85184	2.69697
943	LO-power	1.98018	1.97035	1.98185	1.85184	2.69697
949	L0-boundary	1.96827	1.95818	1.96972	1.84327	2.65695
EPLM:CCC						
4800	Cryostat Cover door	66.22202	62.11184	64.27164	58.91027	293
4801	Cover Heat Shield CHS	65.49632	60.98729	63.35012	58.07794	237.42108
4802	Internal MLI -X side	65.64671	61.21747	63.53788	58.24748	251.75313
4803	Internal MLI +X side	66.08166	61.89153	64.09029	58.74642	284.27397
4810	Inlet Junction	66.15265	62.00374	64.18335	58.82963	288.27276
4811	Outlet Junction	66.15265	62.00374	64.18335	58.82963	288.27276
4820	Cover Dewar	4.2	4.2	4.2	4.2	4.2
4821	GHe cover dome inlet	5	5	5	5	5
4822	GHe cover shield outlet	5	5	5	5	5
4823	GHe cover dome outlet	5	5	5	5	5
EPLM:HSS						
7000	SOLGEN CELLS Mid low	396.24218	371.24837	386.9982	371.17771	293
7001	SOLGEN CELLS -Y low	375.6187	351.93652	366.85863	351.85806	293
7002	SOLGEN CELLS +Y low	375.70372	352.04482	366.95505	352.00081	293
7010	SOLGEN CELLS Mid cent	397.53153	372.50356	388.28119	372.50052	293
7011	SOLGEN CELLS -Y cent	376.4956	352.80091	367.73775	352.79688	293
7012	SOLGEN CELLS +Y cent	376.49512	352.80106	367.73755	352.79791	293
7020	SOLGEN CELLS Mid up	395.57017	370.23704	386.19238	370.23352	293
7021	SOLGEN CELLS -Y up	374.49413	350.36598	365.55054	350.34342	293
7022	SOLGEN CELLS +Y up	374.48553	350.35706	365.54182	350.33468	293
7050	SUNSHADE OSR Mid low	277.69929	224.04595	254.30762	224.0373	293
7051	SUNSHADE OSR -Y low	260.70228	210.66835	238.8634	210.65855	293
7052	SUNSHADE OSR +Y low	260.69964	210.66454	238.86034	210.65578	293
7053	SUNSHADE flap -Y	220.43029	182.98197	204.60138	182.97106	293
7054	SUNSHADE flap +Y	220.43094	182.98129	204.60155	182.972	293
7060	SUNSHADE OSR Mid lcen	276.18546	219.38686	251.69039	219.38486	293
7061	SUNSHADE OSR -Y lcen	258.43187	205.1362	235.40198	205.13279	293
7062	SUNSHADE OSR +Y lcen	258.43168	205.13568	235.40168	205.13261	293
7070	SUNSHADE OSR Mid ucen	276.11541	219.09748	251.5615	219.09727	293
7071	SUNSHADE OSR -Y ucen	258.43893	204.93144	235.35396	204.92999	293
7072	SUNSHADE OSR +Y ucen	258.43876	204.93115	235.35376	204.9299	293
7080	SUNSHADE OSR Mid up	276.15398	219.12818	251.60058	219.12814	293
7081	SUNSHADE OSR -Y up	261.46478	207.41497	238.19678	207.41478	293
7082	SUNSHADE OSR +Y up	261.46471	207.41489	238.19671	207.41472	293
7100	SOLGEN MLI Mid low	271.5746	254.03007	264.94627	253.17515	293
7101	SOLGEN MLI -Y low	258.55639	241.76463	252.16453	240.55928	293
7102	SOLGEN MLI +Y low	258.12119	241.38411	251.76253	240.32589	293
7103	SOLGEN -x rib MLI +Z low	282.39015	263.49638	275.03145	261.24163	293

Node	LABEL	Orbit hot T [K]	Orbit cold T [K]	Orbit avg T [K]	Orbit Safe T [K]	Ground T [K]
7104	SOLGEN -x rib MLI -Y low	267.6625	249.64911	260.57687	246.8595	293
7105	SOLGEN -x rib MLI +Y low	267.50562	249.51534	260.43233	246.78739	293
7106	SOLGEN -x rib MLI +Z up	269.93872	252.65933	263.47437	252.24124	293
7107	SOLGEN -x rib MLI -Y up	256.10657	239.71986	249.97271	239.27411	293
7108	SOLGEN -x rib MLI +Y up	255.80274	239.44868	249.68632	239.08784	293
7110	SOLGEN MLI Mid cent	269.59699	252.36766	263.14706	251.90992	293
7111	SOLGEN MLI -Y cent	256.17289	239.78289	250.02373	239.22925	293
7112	SOLGEN MLI +Y cent	255.84509	239.46961	249.70532	238.99253	293
7120	SOLGEN MLI Mid up	268.78122	251.35842	262.25815	250.94062	293
7121	SOLGEN MLI -Y up	255.17772	238.535	248.92962	238.03028	293
7122	SOLGEN MLI +Y up	254.81111	238.1842	248.57236	237.75047	293
7130	SOLGEN MLI Mid up2	267.02562	249.57609	260.49659	249.40932	293
7131	SOLGEN MLI -Y up2	253.24943	236.57764	246.99469	236.35571	293
7132	SOLGEN MLI +Y up2	253.25658	236.58069	247.00126	236.38182	293
7133	SOLGEN +x rib MLI +Z low	270.47156	252.88545	263.86548	252.32579	293
7134	SOLGEN +x rib MLI -Y low	257.06834	240.24675	250.73066	239.59666	293
7135	SOLGEN +x rib MLI +Y low	256.80552	239.99853	250.47786	239.41749	293
7136	SOLGEN +x rib MLI +Z up	268.13852	250.38926	261.45895	250.17651	293
7137	SOLGEN +x rib MLI -Y up	254.64142	237.64905	248.22948	237.39428	293
7138	SOLGEN +x rib MLI +Y up	254.4916	237.50925	248.08479	237.27255	293
7140	SUNSHADE MLI Mid low2	202.45108	167.81586	187.22816	167.2042	293
7141	SUNSHADE MLI -Y low2	191.66555	159.72555	177.59641	158.92697	293
7142	SUNSHADE MLI +Y low2	191.40776	159.39388	177.31112	158.69187	293
7143	SSHADe rib MLI +Z low	201.02185	169.32433	187.05839	168.45492	293
7144	SSHADe rib MLI -Y low	190.72189	161.51199	177.82681	160.38202	293
7145	SSHADe rib MLI +Y low	190.29451	160.95214	177.34735	159.96254	293
7146	SSHADe rib MLI +Z up	192.85839	158.26328	177.68586	157.77674	293
7147	SSHADe rib MLI -Y up	181.72865	149.57331	167.60807	149.07553	293
7148	SSHADe rib MLI +Y up	181.55432	149.35574	167.41769	148.89399	293
7150	SUNSHADE MLI Mid low	199.54225	163.44316	183.71846	162.99405	293
7151	SUNSHADE MLI -Y low	188.47606	155.0909	173.81422	154.57336	293
7152	SUNSHADE MLI +Y low	188.32094	154.87746	173.63723	154.40446	293
7153	SUNSHADE flap MLI -Y	166.07795	140.78204	155.26055	140.17215	293
7154	SUNSHADE flap MLI +Y	166.11881	140.82519	155.30314	140.23208	293
7160	SUNSHADE MLI Mid lcen	195.46797	156.92405	178.76711	156.66208	293
7161	SUNSHADE MLI -Y lcen	183.66967	147.81876	168.08546	147.47996	293
7162	SUNSHADE MLI +Y lcen	183.64302	147.7772	168.05353	147.46041	293
7170	SUNSHADE MLI Mid ucen	191.93344	152.398	174.903	152.38381	293
7171	SUNSHADE MLI -Y ucen	179.97096	142.91633	163.97347	142.87224	293
7172	SUNSHADE MLI +Y ucen	179.92978	142.87238	163.93193	142.83547	293
7180	SUNSHADE MLI Mid up	191.69513	152.15304	174.66741	152.14684	293
7181	SUNSHADE MLI -Y up	181.72094	144.22248	165.57459	144.21179	293
7182	SUNSHADE MLI +Y up	181.71053	144.21294	165.56459	144.20179	293
7203	SShld SVM gapMLI mX	255.54637	233.79674	245.07208	212.89855	293
7204	SShld SVM gapMLI mY mX	253.46618	231.95649	243.11474	211.30789	293
7205	SShld SVM gapMLI pY mX	252.76284	231.30333	242.4342	210.69653	293
7206	SShld SVM gapMLI pX	229.76694	211.42865	221.48781	200.25177	293
7207	SShld SVM gapMLI mY pX	216.03635	198.58987	208.04472	186.6338	293
7208	SShld SVM gapMLI pY pX	215.44922	198.03419	207.47472	186.18595	293
7301	STRUT_HSSSVm_01_SVM_end	276.29159	259.34867	268.77487	248.02078	293
7302	STRUT_HSSSVm_01	276.4142	260.70682	269.61795	251.61318	293
7303	STRUT_HSSSVm_01	279.78571	264.7772	273.46765	257.56717	293
7304	STRUT_HSSSVm_01	286.49165	271.64589	280.4131	265.9983	293
7305	STRUT_HSSSVm_01_HSS_end	296.69352	281.45995	290.61353	277.08264	293
7321	STRUT_HSSSVm_02_SVM_end	274.62442	257.60892	267.052	246.05583	293

Node	LABEL	Orbit hot T [K]	Orbit cold T [K]	Orbit avg T [K]	Orbit Safe T [K]	Ground T [K]
7322	STRUT_HSSSV_02	274.42436	258.69154	267.59666	249.44507	293
7323	STRUT_HSSSV_02	277.59759	262.592	271.26278	255.27001	293
7324	STRUT_HSSSV_02	284.21843	269.38994	278.13066	263.65184	293
7325	STRUT_HSSSV_02_HSS_end	294.43772	279.22568	288.35087	274.76329	293
7341	STRUT_HSSSV_03_SVM_end	274.70804	257.68101	267.12985	246.10279	293
7342	STRUT_HSSSV_03	274.51706	258.77115	267.68288	249.49809	293
7343	STRUT_HSSSV_03	277.68781	262.66921	271.34658	255.32201	293
7344	STRUT_HSSSV_03	284.29538	269.45577	278.20206	263.6955	293
7345	STRUT_HSSSV_03_HSS_end	294.49412	279.27414	288.40318	274.79366	293
7361	STRUT_HSSSV_04_SVM_end	275.38446	258.39992	267.83334	246.87871	293
7362	STRUT_HSSSV_04	275.2816	259.53586	268.44992	250.23409	293
7363	STRUT_HSSSV_04	278.36191	263.32747	272.01116	255.89514	293
7364	STRUT_HSSSV_04	284.69699	269.84985	278.59337	263.96978	293
7365	STRUT_HSSSV_04_HSS_end	294.45318	279.25348	288.35973	274.63415	293
7401	STRUT_HSSCVV_05_CVV_end	91.88151	87.45825	89.95675	84.60836	293
7402	STRUT_HSSCVV_05	133.61791	127.6187	131.16033	125.89937	293
7403	STRUT_HSSCVV_05	170.74234	163.78789	168.02007	162.78882	293
7404	STRUT_HSSCVV_05	215.88894	207.18837	212.62764	206.67946	293
7405	STRUT_HSSCVV_05_HSS_end	289.03464	275.24856	283.99845	275.07067	293
7421	STRUT_HSSCVV_06_CVV_end	100.81947	94.62484	98.12332	91.46984	293
7422	STRUT_HSSCVV_06	144.52187	136.73437	141.29908	134.74189	293
7423	STRUT_HSSCVV_06	181.14493	172.75737	177.82378	171.55659	293
7424	STRUT_HSSCVV_06	224.65863	214.94914	220.98902	214.33208	293
7425	STRUT_HSSCVV_06_HSS_end	294.70217	280.29115	289.42612	280.07994	293
7441	STRUT_HSSCVV_07_CVV_end	101.06084	94.82859	98.34771	91.61574	293
7442	STRUT_HSSCVV_07	144.93503	137.08418	141.68265	134.9957	293
7443	STRUT_HSSCVV_07	181.60048	173.14241	178.24706	171.84803	293
7444	STRUT_HSSCVV_07	224.99562	215.23389	221.30163	214.55102	293
7445	STRUT_HSSCVV_07_HSS_end	294.80368	280.37925	289.52104	280.144	293
7461	STRUT_HSSCVV_08_CVV_end	93.2595	88.55229	91.2079	85.47272	293
7462	STRUT_HSSCVV_08	134.67257	128.48217	132.12899	126.55421	293
7463	STRUT_HSSCVV_08	171.94161	164.75205	169.11293	163.57013	293
7464	STRUT_HSSCVV_08	216.46212	207.66005	213.15404	207.05905	293
7465	STRUT_HSSCVV_08_HSS_end	289.16229	275.35634	284.116	275.14942	293
7501	STRUT_HSSCVV_09_CVV_end	85.17763	78.43382	82.23759	75.39788	293
7502	STRUT_HSSCVV_09	116.44681	104.52336	111.43085	102.55597	293
7503	STRUT_HSSCVV_09	144.75704	128.16526	137.85242	126.89599	293
7504	STRUT_HSSCVV_09	175.80072	152.76142	166.16934	152.04122	293
7505	STRUT_HSSCVV_09_HSS_end	219.47556	184.44797	204.58757	184.19885	293
7521	STRUT_HSSCVV_10_CVV_end	90.98518	83.16531	87.57749	80.00571	293
7522	STRUT_HSSCVV_10	126.69965	113.23107	121.0301	111.10295	293
7523	STRUT_HSSCVV_10	156.13094	138.13607	148.63669	136.74012	293
7524	STRUT_HSSCVV_10	187.85147	163.43046	177.66952	162.62906	293
7525	STRUT_HSSCVV_10_HSS_end	233.61111	196.52932	217.87553	196.23305	293
7541	STRUT_HSSCVV_11_CVV_end	91.20055	83.36306	87.7866	80.14931	293
7542	STRUT_HSSCVV_11	127.03979	113.55481	121.36557	111.37153	293
7543	STRUT_HSSCVV_11	156.50845	138.49267	149.00634	137.04136	293
7544	STRUT_HSSCVV_11	188.12192	163.6942	177.93766	162.8501	293
7545	STRUT_HSSCVV_11_HSS_end	233.71798	196.63461	217.98164	196.32052	293
7561	STRUT_HSSCVV_12_CVV_end	85.47326	78.6966	82.51918	75.58943	293
7562	STRUT_HSSCVV_12	116.90417	104.94501	111.87362	102.8791	293
7563	STRUT_HSSCVV_12	145.13364	128.53228	138.22519	127.17413	293
7564	STRUT_HSSCVV_12	176.02842	152.99828	166.40186	152.22005	293
7565	STRUT_HSSCVV_12_HSS_end	219.52485	184.5105	204.64273	184.24162	293
7601	STRUT_HSSCVV_13_SSH_end	328.23847	303.40671	318.52719	303.3714	293

Node	LABEL	Orbit hot T [K]	Orbit cold T [K]	Orbit avg T [K]	Orbit Safe T [K]	Ground T [K]
7602	STRUT_HSSCVV_13_SSD_end	276.43764	238.42011	260.25779	238.39036	293
7621	STRUT_HSSCVV_14_SSH_end	328.26835	303.43243	318.55523	303.39305	293
7622	STRUT_HSSCVV_14_SSD_end	276.45705	238.43826	260.27659	238.40416	293
EPLM:TEL						
8001	TEL_M1_MIRROR	84.98635	76.31228	81.04168	74.54818	293
8002	TEL_M1_MIRROR	85.00861	76.32751	81.0606	74.56355	293
8003	TEL_M1_MIRROR	84.9387	76.27621	80.99943	74.5134	293
8004	TEL_M1_MIRROR	84.95827	76.28941	81.01601	74.52654	293
8005	TEL_M1_MIRROR	84.98562	76.31157	81.04096	74.54764	293
8006	TEL_M1_MIRROR	85.00763	76.32662	81.05966	74.56285	293
8040	TEL_HEXAPOD	82.33118	74.23978	78.65671	72.67947	293
8050	TEL_M2_MIRROR	82.32593	74.23614	78.65218	72.67597	293
8060	TEL_M2_SCREEN	66.53203	57.85882	62.62236	56.95691	293
8070	TEL_M2_HEATER	81.78309	73.71353	78.11217	72.15293	293
8101	TEL_M1_SLI1	92.51387	83.21511	88.36772	81.45633	293
8102	TEL_M1_SLI1	92.47556	83.10896	88.29511	81.34791	293
8103	TEL_M1_SLI1	92.8855	83.6088	88.75965	81.85334	293
8104	TEL_M1_SLI1	91.9845	82.73961	87.86629	80.98836	293
8105	TEL_M1_SLI1	92.46676	83.16909	88.32086	81.41529	293
8106	TEL_M1_SLI1	92.40827	83.04069	88.22704	81.28923	293
8110	TEL_M1_BAFFLE UP DISC	77.41092	68.2903	73.27712	66.91741	293
8111	TEL_M1_BAFFLE CYL	88.5534	79.3411	84.44788	77.68475	293
8112	TEL_M1_BAFFLE LOW DISC	91.68801	82.81468	87.78589	81.00877	293
8201	TEL_M1_SLI2	103.36337	93.18998	98.91416	91.371	293
8202	TEL_M1_SLI2	103.974	93.40229	99.33994	91.57783	293
8205	TEL_M1_SLI2	103.20918	93.03421	98.75898	91.23953	293
8206	TEL_M1_SLI2	103.74709	93.16871	99.10957	91.38432	293
8301	TEL_M1_SLI3	120.17804	108.95188	115.35554	106.9129	293
8302	TEL_M1_SLI3	114.80361	102.38725	109.3845	100.45323	293
8303	TEL_M1_SLI3	88.40371	79.88737	84.66921	78.16178	293
8304	TEL_M1_SLI3	86.46154	77.98519	82.73093	76.28259	293
8305	TEL_M1_SLI3	119.39188	108.16689	114.57054	106.25924	293
8306	TEL_M1_SLI3	114.27045	101.81144	108.832	99.99629	293
8311	TEL_M1_SLI3	109.52951	99.20242	105.05688	97.33822	293
8313	TEL_M1_SLI3	103.83747	93.99716	99.55729	92.18618	293
8315	TEL_M1_SLI3	109.40463	99.07398	104.93038	97.23344	293
8502	TEL_M1_HEATER	85.33803	76.62165	81.37293	74.85498	293
8504	TEL_M1_HEATER	85.29143	76.58849	81.33296	74.82309	293
8506	TEL_M1_HEATER	85.33756	76.6204	81.37206	74.85418	293
99998	Space	3	3	3	3	3
EPLM:LOU						
4210	LOU baseplate	130.21664	126.73361	128.67211	97.23449	293
4262	LOU mx side MLI	139.58005	131.3028	136.00243	120.10025	293
SVM						
6001	SVM wall pZ	318	291	305	265	293
6002	SVM wall pYpZ	318	291	305	265	293
6003	SVM wall pY	318	291	305	265	293
6004	SVM wall pYmZ	318	291	305	265	293
6005	SVM wall mZ	318	291	305	265	293
6006	SVM wall mYmZ	318	291	305	265	293
6007	SVM wall mY	318	291	305	265	293
6008	SVM wall mYpZ	318	291	305	265	293

Node	LABEL	Orbit hot	Orbit cold	Orbit avg	Orbit Safe	Ground
		T [K]	T [K]	T [K]	T [K]	T [K]
6020	SVM I/F to CVV struts	293	293	293	245	293
6021	SVM I/F to SVM shield	293	266	280	240	293
6022	SVM I/F to Sshld str.	293	266	280	240	293
6023	SVM I/F to waveguides	293	266	280	240	293
6024	SVM I/F to harness	293	266	280	240	293
6051	SVM top pZ	230	203	216	168	293
6052	SVM top pYpZ	230	203	216	168	293
6053	SVM top pY	230	203	216	168	293
6054	SVM top pYmZ	230	203	216	168	293
6055	SVM top mZ	230	203	216	168	293
6056	SVM top mYmZ	230	203	216	168	293
6057	SVM top mY	230	203	216	168	293
6058	SVM top mYpZ	230	203	216	168	293
6101	SVM top disc pZ	230	203	216	168	293
6102	SVM top disc pYpZ	230	203	216	168	293
6103	SVM top disc pY	230	203	216	168	293
6104	SVM top disc pYmZ	230	203	216	168	293
6105	SVM top disc mZ	230	203	216	168	293
6106	SVM top disc mYmZ	230	203	216	168	293
6107	SVM top disc mY	230	203	216	168	293
6108	SVM top disc mYpZ	230	203	216	168	293
6151	MLI THR pZ	230	203	216	168	293
6152	MLI THR pY	230	203	216	168	293
6153	MLI THR mZ	230	203	216	168	293
6154	MLI THR mY	230	203	216	168	293
6155	MLI SAS pZ	230	203	216	168	293
6156	MLI SAS pZ BRK	230	203	216	168	293
6157	MLI SAS mZ	230	203	216	168	293
6158	MLI SAS mZ BRK	230	203	216	168	293
6159	MLI AAD	230	203	216	168	293
6160	MLI VMC	230	203	216	168	293
6161	MLI SREM	230	203	216	168	293

END OF DOCUMENT

	Name	Dep./Comp.		Name	Dep./Comp.
	Alberti von Mathias Dr.	ASG23		Schuler Günter	ASA42
	Baldock Richard	FAE12	X	Schweickert Gunn	ASG23
	Barlage Bernhard	AED13		Sonn Nico	ASG51
	Bayer Thomas	ASA42		Steininger Eric	AED32
	Brune Holger	ASA45	X	Stritter Rene	AED11
	Edelhoff Dirk	AED2		Suess Rudi	OTN/ASA44
	Fehringer Alexander	ASG13		Theunissen Martijn	DSSA
X	Fricke Wolfgang Dr.	AED 65		Vascotto Riccardo	AED11
	Geiger Hermann	ASA42	X	Wagner Klaus	ASG23
	Grasl Andreas	OTN/ASA44	X	Wietbrock Walter	AET12
	Grasshoff Brigitte	AET12		Wöhler Hans	ASG23
	Hamer Simon	Terma		Wössner Ulrich	ASE252
	Hendrikse Jeffrey	HE Space		Zumstein Armin	ASQ42
	Hendry David	Terma			
	Hengstler Reinhold	ASA42			
X	Hinger Jürgen	ASG23			
X	Hohn Rüdiger	AED65			
	Hölzle Edgar Dr.	AED32			
	Huber Johann	ASA42			
	Hund Walter	ASE252			
X	Idler Siegmund	AED312			
	Ivány von András	FAE12			
X	Jahn Gerd Dr.	ASG23			
	Kalde Clemens	ASM2			
	Kameter Rudolf	OTN/ASA42			
X	Kettner Bernhard	AET42	X	ESA/ESTEC	ESA
	Knoblauch August	AET32	X	Thales Alenia Space Cannes	TAS-F
	Koelle Markus	ASA43		Thales Alenia Space Torino	TAS-I
	Koppe Axel	AED312			
X	Kroeker Jürgen	AED65		Instruments:	
	La Gioia Valentina	Terma	X	MPE (PACS)	MPE
X	Lang Jürgen	ASE252	X	RAL (SPIRE)	RAL
	Langenstein Rolf	AED15	X	SRON (HIFI)	SRON
X	Langfermann Michael	ASA41			
	Martin Olivier	ASA43			
	Maukisch Jan	ASA43		Subcontractors:	
	Much Christoph	ASA43		Austrian Aerospace	AAE
	Müller Jörg	ASA42		Austrian Aerospace	AAEM
	Müller Martin	ASA43		BOC Edwards	BOCE
	Peltz Heinz-Willi	ASG13		Dutch Space Solar Arrays	DSSA
	Pietroboni Karin	AED65		EADS Astrium Sub-Subsyst. & Equipment	ASSE
	Platzer Wilhelm	AED2		EADS CASA Espacio	CASA
	Reichle Konrad	ASA42		EADS CASA Espacio	ECAS
	Runge Axel	OTN/ASA44		European Test Services	ETS
	Sauer Maximilian Dr.	AED65		Patria New Technologies Oy	PANT
X	Schink Dietmar	AED32		SENER Ingenieria SA	SEN
	Schmidt Thomas	AED15		Thales Alenia Space, Antwerp	TAS-ETCA