

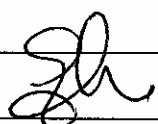





HERSCHEL / PLANCK
SVM TCS THERMAL ANALYSIS REPORT

<i>Written by</i>	<i>Responsibility</i>
	+ hand written signature if no workflow tool exists
F. Tessarin / M. Compassi	Author 
<i>Verified by</i>	
Enrico Sacchi	Checker 
<i>Approved</i>	
Roberto Droetto	Configuration Management 
Anselmo Cecchetti	Product Assurance 
Marco Sias	System Manager 
Michele Cairola	Thermal System 
Paolo Musi	Program Manager 
Documentation Manager	
Rosetta Cavaglià	

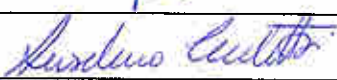
The validations evidence are kept through the documentation management system

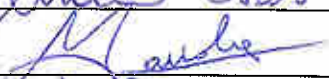
DOCUMENT CHANGE RECORD

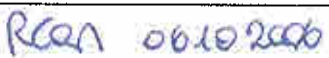
ISSUE	DATE	§ CHANGE RECORD	AUTHOR
01	13/11/2002	New Issue	
02	26/03/2004	Update for CDR	
03	14/07/2004	Update System CDR	
04	28/02/2005	Update for System CDR RID disposition	
05	24/02/2006	Updated post correlation activities Par 1, Par 2, Par 3.1.1, 3.1.2., 3.1.3., 3.1.5., Par 7.1, Par 8.1, 8.2, 8.3, 8.4, 9.1	
06	29/09/2006	Updating for MQR Step 3	

TABLE OF CONTENTS

1	INTRODUCTION	9
2	APPLICABLE AND REFERENCE DOCUMENTS	11
2.1	APPLICABLE DOCUMENTS	11
2.2	REFERENCE DOCUMENTS	13
2.3	LIST OF ACRONYMS	13
3	HERSCHEL MODELS DESCRIPTION	14
3.1.	HERSCHEL GMM AND TMM UPDATE TO FLIGHT CONFIGURATION	18
3.1.1	<i>HERSCHEL External GMM Variations</i>	<i>19</i>
3.1.2	<i>HERSCHEL Internal GMM Variations</i>	<i>31</i>
3.1.3	<i>HERSCHEL TMM Variations</i>	<i>36</i>
3.1.4	<i>HERSCHEL RCS Model Variations</i>	<i>39</i>
3.1.5	<i>HERSCHEL Power Dissipations Variations</i>	<i>51</i>
3.1.6	<i>HERSCHEL Units Conductors Variations</i>	<i>53</i>
3.1.7	<i>HERSCHEL SVM-Payload I/F points.....</i>	<i>56</i>
4	PLANCK MODELS DESCRIPTION.....	58
4.1	PLANCK GMM AND TMM VARIATIONS AFTER CORRELATION ACTIVITY (JULY 2006).....	63
4.1.1	<i>PLANCK External GMM Variations</i>	<i>64</i>
4.1.2	<i>PLANCK Internal GMM Variations</i>	<i>75</i>
4.1.3	<i>PLANCK TMM Variations</i>	<i>79</i>
4.1.4	<i>PLANCK RCS Model.....</i>	<i>81</i>
4.1.5	<i>PLANCK Power dissipations</i>	<i>108</i>
4.1.6	<i>PLANCK Units Conductors</i>	<i>112</i>
4.1.7	<i>PLANCK SVM-Payload I/F points</i>	<i>114</i>
4.1.8	<i>DCCU configuration</i>	<i>115</i>
5	HERSCHEL & PLANCK CONDUCTIVE COUPLINGS.....	116
5.1	MLI CONDUCTIVITY	116
5.2	UNIT-PANEL CONDUCTIVITY	117
5.3	HONEYCOMB PANEL CONDUCTIVITY.....	118
5.4	DOUBLER – PANEL CONDUCTIVITY	120
5.5	CLEATS LINEAR CONDUCTIVITY	120
5.6	PLANCK HEAT PIPES CONDUCTIVITY	122
5.7	PLANCK SOLAR ARRAY CONDUCTIVITY	123
5.8	LVA RING MODIFICATION AFTER THE PFM#1 TEST.....	128
6	HERSCHEL & PLANCK MASS UPDATING.....	129
7	SVM INTERFACE REQUIREMENTS	131
7.1	HERSCHEL REQUIREMENTS	131
7.2	PLANCK REQUIREMENTS	147
8	THERMAL ANALYSIS	167
8.1	HERSCHEL THERMAL ANALYSIS	167
8.2	HERSCHEL HEATER SIZING AND BREAKDOWN	170

8.3	THERMAL STABILITY	173
8.4	HERSCHEL THERMAL ANALYSIS RESULTS.....	174
8.4.1	<i>Transient Results</i>	174
8.4.2	<i>Transient Cases with Attitude Change Results</i>	192
8.4.3	<i>Heater Power Summary</i>	194
8.4.4	<i>Redundancy Analysis</i>	196
8.4.5	<i>STR Analysis: STR1 and STR2 operative together for the entire S/C life</i>	201
8.5	PLANCK THERMAL ANALYSIS.....	206
8.5.1	<i>SCC dissipation profile</i>	208
8.5.2	<i>Planck Heater Sizing and Breakdown</i>	212
8.5.3	<i>Thermal stability</i>	214
8.5.4	<i>Planck thermal analysis results</i>	215
8.5.4.1	Transient nominal results	215
8.5.4.2	Change of attitude transient case results	231
8.5.4.3	Redundancy Analysis	239
8.5.4.4	Heater Power Summary.....	256
8.5.4.5	Sun trapping on Solar Array.....	258
9	CONCLUSIONS	259
9.1	HERSCHEL.....	259
9.2	PLANCK	262
10	HERSCHEL: TEMPERATURE PLOTS.....	264
10.1	HERSCHEL RESULTS OF CASE B.....	264
10.2	HERSCHEL RESULTS OF CASE G	271
10.3	HERSCHEL RESULTS OF CASE I.....	278
10.4	HERSCHEL RESULTS OF CASE P.....	285
10.5	HERSCHEL RESULTS OF CASE Q	292
11	PLANCK: TEMPERATURE PLOTS	299
11.1	PLANCK: PLOTS OF TRANSIENT NOMINAL ANALYSIS CASE A3	299
11.2	PLANCK: PLOTS OF TRANSIENT NOMINAL ANALYSIS CASE B2	334
11.3	PLANCK: PLOTS OF TRANSIENT NOMINAL ANALYSIS CASE C	369

LIST OF TABLES

Table 3.1.1-1 HERSCHEL – External MLI modifications.....	19
Table 3.1.1-2 HERSCHEL – SVM radiators areas updated post correlation	26
Table 3.1.1-2 HERSCHEL – SVM radiators areas updated according to [AD31]	26
Table 3.1.1-3 HERSCHEL – Thrusters GMM.....	27
Table 3.1.1-4 HERSCHEL – SVM thermal-optical properties	31
Table 3.1.2-1 HERSCHEL – HIFI Panels GMM	31
Table 3.1.2-2 HERSCHEL – TWT Panel and units GMM remodelisation	34
Table 3.1.3-1 HERSCHEL – HIFI Panels TMM after correlation.....	36
Table 3.1.3-1 HERSCHEL – HIFI Panels TMM according to [AD31]	36
Table 3.1.3-2 HERSCHEL – TT&C Panels TMM	37
Table 3.1.3-3 HERSCHEL – Thrusters TMM	38
Table 3.1.3-4 HERSCHEL – Thrusters brackets/Bottom Floor linear couplings	38
Table 3.1.4-1 HERSCHEL – RCS model summary	39
Table 3.1.5-1 HERSCHEL – Payload Units operating modes	51
Table 3.1.5-2 HERSCHEL - Units Power Dissipations	53
Table 3.1.6-1 HERSCHEL - Units-Panels conductance.....	55
Table 3.1.7-1 HERSCHEL – SVM-Payload I/F points	56
Table 4.1.2-1 PLANCK – TT&C Panel internal GMM modifications	75
Table 4.1.3-2 PLANCK – TCS He Tanks Lines power.....	79
Table 4.1.3-3 PLANCK – TCS Propellant Tanks Lines power.....	79
Table 4.1.3-1 PLANCK – TCS Lines Thresholds	80
Table 4.1.4-1 PLANCK – RCS model summary.....	81
Table 4.1.4-2 PLANCK – RCS Thermistors positions.....	81
Table 4.1.5-1 PLANCK – Payload Units operating modes	108
Table 4.1.5-2 PLANCK – Scientific Mode Power dissipations	109
Table 4.1.5-3 PLANCK – Telecom Mode Power dissipations.....	111
Table 4.1.6-1 PLANCK – Units-Panels conductors	113
Table 4.1.3-1 PLANCK – SVM-Payload I/F points.....	114
Table 5-1 - MLI Thermal Conductivity for different number of layers	117
Table 5.3-1 HERSCHEL – SVM Honeycomb panels & structural parts thermal properties	119
Table 5.3-2 PLANCK – SVM Honeycomb panels thermal properties	120
Table 5.3-3 HERSCHEL – SVM struts conductivity	120
Table 5.5-1 Cleats and inserts linear conductors	121
Table 6-1 PLANCK – Summary mass comparison between TMM and mechanical mass budget	129
Table 6-2 HERSCHEL – Mass Updating from BEE mechanical mass budget	129
Table 6-3 PLANCK – Mass Updating from BEE mechanical mass budget	130
Table 7.1-1 HERSCHEL – Requirements.....	132
Table 7.1-2 HERSCHEL - REQ ITP-100-H.....	135
Table 7.1-3 HERSCHEL - REQ ITP-120-H.....	135
Table 7.1-4 HERSCHEL - REQ ITP-130-H.....	136
Table 7.1-5 HERSCHEL REQ ITP-135-H	136
Table 7.1-6 HERSCHEL stability requirement (Cold case).....	137
Table 7.1-7 HERSCHEL stability requirement (Hot case).....	138
Table 7.1-8 HERSCHEL STR stability requirement (Cold case)	139
Table 7.1-9 HERSCHEL STR stability requirement (Hot case)	139
Table 7.1-10 HERSCHEL STR stability requirement (Cold Case)	140
Table 7.1-11 HERSCHEL STR stability requirement (Hot Case)	140

Controlled Distribution



REFERENCE : H-P-RP-AI-0040

DATE : 29/SEP/06

ISSUE : 06

Page : 6/405

Table 7.1-12a HERSCHEL STR stability requirement (Cold Case).....	141
Table 7.1-12b HERSCHEL STR stability requirement (Hot Case).....	141
Table 7.1-13 HERSCHEL temperature gradient of SVM/PLM I/F points.....	145
Table 7.2-1 PLANCK – SVM I/F requirements.....	148
Table 7.2-2 PLANCK – ITP-150-P Temperature Results.....	149
Table 7.2-3 PLANCK – ITP-180-P Temperature Results.....	149
Table 7.2-4 PLANCK – ITP-200-P Temperature Results.....	150
Table 7.2-5 PLANCK – ITP-210-P Temperature Results.....	151
Table 7.2-6 PLANCK –ITP-170-P Flux Results.....	156
Table 7.2-7 PLANCK - ITP-170-P.....	161
Table 7.2-8 PLANCK - ITP-220-P.....	162
Table 7.2-9 PLANCK - ITP-230-P.....	163
Table 7.2-10 PLANCK - ITI-030-P.....	164
Table 7.2-11a PLANCK – SCC STABILITY.....	165
Table 7.2.11b PLANCK – gradient between each tank.....	166
Table 8.1-1 HERSCHEL – Analysis Cases.....	168
Table 8.2-1 HERSCHEL – Heater Circuits Breakdown and Temperature Thresholds.....	172
Table 8.4.1-1 HERSCHEL - Units Temperature results: Sizing Case BOL Nominal G and H.....	178
Table 8.4.1-2 HERSCHEL - Units Temperature results: Sizing Case BOL Survival I.....	182
Table 8.4.1-3 HERSCHEL - Units Temperature results: Sizing Case EOL Nominal A, B and C.....	187
Table 8.4.1-4 HERSCHEL - Units Temperature results: Sizing Case EOL Nominal D, E and F.....	191
Table 8.4.2-1 HERSCHEL – Transient cases: Min and Max temperatures (without uncertainty).....	193
Table 8.4.3-1 HERSCHEL – Average Heater Power Consumption in Nominal Cases.....	195
Table 8.4.4-1 HERSCHEL – Redundancy analysis temperature results.....	200
Table 8.5-1- PLANCK Transient nominal analysis cases.....	206
Table 8.5.1-1 PLANCK - Simplified BOL SCC model.....	209
Table 8.5.1-2 PLANCK - Simplified EOL SCC model.....	210
Table 8.5.1-3 PLANCK - Gas gap conductance.....	211
Table 8.5.2-1 PLANCK – Heater Circuits Breakdown and Temperature Thresholds.....	212
Table 8.5.4.1 PLANCK – Units Temperature Results.....	215
Table 8.5.4.2-1 PLANCK – Attitude Change temperatures.....	238
Table 8.5.4.3-1 PLANCK - Heater power need.....	256



LIST OF FIGURES

Figure 3-1 HERSCHEL – Overall view +Z.....	15
Figure 3-2 HERSCHEL – Overall view -Z.....	16
Figure 3-3 HERSCHEL – Internal overall View.....	17
Figure 3.1.1-1 HERSCHEL – SVM external panels radiators layout.....	20
Figure 3.1.1-2a: HERSCHEL - +Y +Z MLI Lateral Panel & Units Internal View (See internal detail below).....	21
Figure 3.1.1-2b: HERSCHEL - +Y MLI Lateral Panel & Units Internal View.....	22
Figure 3.1.1-2c: HERSCHEL - +Y -Z MLI Lateral Panel & Units Internal View.....	22
Figure 3.1.1-2d: HERSCHEL - -Z MLI Lateral Panel & Units Internal View.....	23
Figure 3.1.1-2e: HERSCHEL - -Y -Z MLI Lateral Panel & Units Internal View after correlation.....	23
Figure 3.1.1-: HERSCHEL - -Y -Z MLI Lateral Panel & Units Internal View according to [AD31].....	24
Figure 3.1.1-2f HERSCHEL - -Y MLI Lateral Panel & Units Internal View.....	24
Figure 3.1.1-2g: HERSCHEL - -Y +Z MLI Lateral Panel & Units Internal View.....	25
Figure 3.1.1-3 HERSCHEL – Thruster external view, Flight Configuration without external insulators.....	28
Figure 3.1.1-4 HERSCHEL – Thruster external view, TV/TB Configuration without external insulators.....	28
Figure 3.1.1-5 HERSCHEL – Thruster internal view.....	29
Figure 3.1.2-1 HERSCHEL – HIFI Short Panel new local mesh according to [AD31] in blue.....	32
Figure 3.1.2-2 HERSCHEL – HIFI Long Panel new local mesh.....	32
Figure 3.1.2-3 HERSCHEL – FHWOV/FHWOH old model.....	33
Figure 3.1.2-4 HERSCHEL – FHWOV/FHWOH new model.....	33
Figure 3.1.2-5 HERSCHEL – TT&C doublers new local mesh.....	35
Figure 3.1.2-6 HERSCHEL – TWT1 (X=6) / TWT2 (X=7) new model.....	35
Figure 3.1.4-1 HERSCHEL – RCS line9.....	40
Figure 3.1.4-2 HERSCHEL – RCS line9.....	41
Figure 3.1.4-3 HERSCHEL – RCS line9.....	42
Figure 3.1.4-4 HERSCHEL – RCS line11.....	43
Figure 3.1.4-5 HERSCHEL – RCS line11.....	44
Figure 3.1.4-6 HERSCHEL – RCS line35.....	45
Figure 3.1.4-7 HERSCHEL – RCS line37.....	46
Figure 3.1.4-8 HERSCHEL – RCS line37-45.....	47
Figure 3.1.4-9 HERSCHEL – RCS line45.....	48
Figure 3.1.4-10 HERSCHEL – RCS line46.....	49
Figure 3.1.4-11 HERSCHEL – RCS line47.....	50
Figure 3.1.7-1 HERSCHEL – I/F points with PLM.....	57
Figure 4-1 PLANCK - Overall view.....	59
Figure 4-2 PLANCK - Overall view.....	60
Figure 4-3 PLANCK - Overall view.....	60
Figure 4-5 PLANCK – Internal overall View.....	62
Figure 4.1.1-1 PLANCK – Solar Array thermal-optical properties.....	67
Figure 4.1.1-2 PLANCK TT&C -Y external panel.....	68
Figure 4.1.1-5 PLANCK PWR -Y+Z external panel.....	71
Figure 4.1.1-6 PLANCK +Y external panel new GMM nodes.....	72
Figure 4.1.1-7 PLANCK Solar Arrays, +X side.....	73
Figure 4.1.1-8 PLANCK Solar Arrays, -X side.....	74
Figure 4.1.2-1 PLANCK TT&C -Y internal panel.....	76
Figure 4.1.2-2 PLANCK He Tanks.....	77
Figure 4.1.2-3 PLANCK Star Trackers MLI; old GMM (left) and new GMM (right).....	78
Figure 4.1.4-1 PLANCK - RCS Line #33.....	82
Figure 4.1.4-2 PLANCK - RCS Line #33.....	83
Figure 4.1.4-3 PLANCK - RCS Line #33.....	84



Controlled Distribution



REFERENCE : H-P-RP-AI-0040

DATE : 29/SEP/06

ISSUE : 06

Page : 8/405

Figure 4.1.4-4 PLANCK - RCS Line #33	85
Figure 4.1.4-5 PLANCK - RCS Line #34	86
Figure 4.1.4-6 PLANCK - RCS Line #34	87
Figure 4.1.4-7 PLANCK - RCS Line #34	88
Figure 4.1.4-8 PLANCK - RCS Line #34	89
Figure 4.1.4-9 PLANCK - RCS Line #34	90
Figure 4.1.4-10 PLANCK - RCS Line #34	91
Figure 4.1.4-11 PLANCK - RCS Line #46	92
Figure 4.1.4-12 PLANCK - RCS Line #46	93
Figure 4.1.4-13 PLANCK - RCS Line #46	94
Figure 4.1.4-14 PLANCK - RCS Line #46	95
Figure 4.1.4-15 PLANCK - RCS Line #46	96
Figure 4.1.4-16 PLANCK - RCS Line #47	97
Figure 4.1.4-17 PLANCK - RCS Line #47	98
Figure 4.1.4-18 PLANCK - RCS Line #47	99
Figure 4.1.4-19 PLANCK - RCS Line #47	100
Figure 4.1.4-20 PLANCK - RCS Line #47	101
Figure 4.1.4-21 PLANCK - RCS Line #47	102
Figure 4.1.4-22 PLANCK - RCS Line #48	103
Figure 4.1.4-23 PLANCK - RCS Line #48	104
Figure 4.1.4-24 PLANCK - RCS Line #48	105
Figure 4.1.4-25 PLANCK - RCS Line #48	106
Figure 4.1.4-26 PLANCK - RCS Line #32 (RCS Units).....	107
Figure 4.1.7-1 PLANCK - PLM I/F attachment points	114
Figure 4.1.8-1 DCE possible heater location	115
Figure 5.2-1 Unit-Panel contact areas	118
Figure 5.5-1 Cleats conductors	121
Figure 5.7-1 PLANCK – Connection via screw	123
Figure 5.7-2 PLANCK – Connection Solar Array-Lateral panel	125
Figure 5.7-3 PLANCK – Connection Solar Array-Cone.....	127
Figure 7.1-1 HERSCHEL STR feet temperature gradient (COLD CASE P)	141
Figure 7.1-2 HERSCHEL STR feet temperature gradient (HOT CASE Q)	142
Figure 7.1-3 HERSCHEL temperature control of GYRO and CRS every 10 seconds	146



1 INTRODUCTION

The purpose of this document is the description of the geometric and thermal mathematical models built for HERSCHEL and PLANCK Service Modules as well as the presentation of the temperature results derived from the Flight thermal analysis performed for both satellites.

After correlation activity some other modifications have been implemented according to the following documentation:

H-P-ASP-CR-0865:	HIFI WOV and WOH thermal control
H-P-ASP-CR-0866:	SPIRE DPU FM ICD update
H-P-ASP-CR-0867:	PACS DPU ICD update
H-P-ASP-CR-0885:	PACS DECMEC ICD update
HP-TN-AI-0131:	RWL dissipation update
CRS EEPROM ALERT – SVM PM#33 (H-P-ASP-MN-7345, AI#7):	CRS heater control
H-P-TN-AI-0069:	Heaters and thermistors description and layout
H-P-1-ASP-TN-0418	Herschel SVM thermal interfaces.
H-P-ASP-CR-0896	SCS/LFI dissipations update

In particular the modifications consist in:

HERSCHEL

- implementation of HIFI units FHWOV and FHWOH linear conductors: 0.3W/K for the middle foot, 0.01W/K for the lateral two feet.
- Radiator sizing and MLI layout updating on HIFI panel –Z-Y: the linear conductor updated distribution leads to a temperature increase in particular on the FHWOV then the radiator area has been increased behind FHWOV.
- Heaters relocation on HIFI panel –Z-Y and –Y to reduce the delta T between feet
- Control law TRP put on the skin panel node under central foot: for FHWOV node 654007 and for FHWOH node 660706 and temperature range applicable at this reference point between 0°C and 10°C
- Residual logic implementation on FHWOV and FHWOH control law
- Power dissipation and thermal properties updating on PACS and SPIRE units
- Power dissipation updating on RW
- Heater lines updating according to H-P-TN-AI-0069 issue 7
- Linear conductor, between cone and LVA adapter, updating according to Planck correlation conclusions
- Heater control on CRS1 and CRS2 between 49.0°C and 49.5°C for the entire S/C life (as for GYRO)
- Heater control on STR primary baffle between 14°C and 14.5°C to improve the stability performances
- Survival threshold of heater lines with control law updated TCS12, TCS16, TCS27, TCS28: a maximum value 4°C less than the nominal set point has been chosen to optimize the stability performances recovery after a survival phase
- PLM boundary temperatures updated according to the last issue of the interface document
- STR verification: two units operative for the entire mission life controlled with control law at higher set point.

PLANCK

- Update of SCC and SCE power values



Controlled Distribution



REFERENCE : H-P-RP-AI-0040

DATE : 29/SEP/06

ISSUE : 06

Page : 10/405

- Update of the Gas Gap conductance array
- Update of power allocated to units
- DCCU baseplate design has been updated with new HC properties
- TCS heater lines have been updated (power values and new heaters)
- Update of thermal-optical properties
- Design changes for RCS heaters lines have been implemented (thresholds variations and wires configurations)



2 APPLICABLE AND REFERENCE DOCUMENTS

2.1 APPLICABLE DOCUMENTS

[AD1]	Herschel/Planck Environment and Tests Requirements	H-P-1-ASPI-SP-0030
[AD2]	General Design & Interface Requirements	H-P-1-ASPI-SP-0027
[AD3]	SVM Mechanical Interface control document	H-P-IC-AI-0001
[AD4]	Reduced Geom. RGMM and Thermal RTMM Math. Models Requirements	H-P-RQ-AI-0002
[AD5]	SVM Requirement Specification	H-P-4-ASPI-SP-0019
[AD6]	SVM Interface Specification	H-P-4-ASPI-IS-0042
[AD7]	TCS Design Description	H-P-RP-AI-0039
[AD8]	PLANCK HEAT-PIPES Network Definition and Interfaces	H-P-TN-AI-0020
[AD9]	Thermal Interface control document	H-P-IC-AI-0002
[AD10]	Instrument Interface Document, Part B (IID-B): High Frequency Instrument	SCI-PT-IIDB/HFI-04141
[AD11]	Instrument Interface Document, Part B (IID-B): Low Frequency Instrument	SCI-PT-IIDB/LFI-04142
[AD12]	Instrument Interface Document, Part B (IID-B): Photo-conductor Instrument	SCI-PT-IIDB/PACS-2126
[AD13]	Instrument Interface Document, Part B (IID-B): Instrument "HIFI"	SCI-PT-IIDB/HIFI-2125
[AD14]	HERSCHEL AND PLANCK SAS Design and Analysis report	HP-4-TNO-RP-S004
[AD15]	HERSCHEL AND PLANCK AAD Design and Analysis Report	HP-4-TNO-RP-A004
[AD16]	THERMAL ANALYSIS FOR LGA OF HERSCHEL-PLANCK	HP-AN-RY-0020
[AD17]	THERMAL ANALYSIS FOR MGA OF HERSCHEL-PLANCK	HP-AN-RY-0021
[AD18]	PLM interface with HERSCHEL STR i01	H-P-ASP-LT-3814
[AD19]	PLANCK SVM Thermal Interfaces	H-P-1-ASP-TN-0417
[AD20]	HERSCHEL SVM Thermal Interfaces	H-P-1-ASP-TN-0418
[AD21]	UNCERTAINTY THERMAL ANALYSIS	H-P-TN-AI-0045
[AD22]	HEATER POWER UNCERTAINTY THERMAL ANALYSIS	H-P-TN-AI-0055
[AD23]	FINE CONTROL LAW ANALYSIS	H-P-TN-AI-0060

Controlled Distribution



REFERENCE : H-P-RP-AI-0040

DATE : 29/SEP/06

ISSUE : 06

Page : 12/405

[AD24] HERSCHEL THERMAL ANALYSIS RESULTS AND BREAKDOWN	H-P-TN-AI-0065
[AD25] PLANCK THERMAL ANALYSIS RESULTS AND BREAKDOWN	H-P-TN-AI-0066
[AD26] Autonomous Star Tracker Thermal and Thermo-elastic analysis Report	H-P-4-GAF-RP-0009
[AD27] REDUCED TMM SYNDA (Northrop Grunman)	654056 9/12/2003
[AD28] RCS lines and units thermal analysis and heaters sizing	H-P-TN-AI-0080
[AD29] HERSCHEL SVM TV/TB TEST CORRELATION REPORT	H-P-RP-AI-0153
[AD30] Thermo-optical Investigation for HERSCHEL SVM STM	TEC/QMC 4314 – issue 2
[AD31] WOV and WOH thermal control	H-P-ASP-CR-0865
[AD32] SPIRE DPU FM ICD update	H-P-ASP-CR-0866
[AD33] PACS DPU ICD update	H-P-ASP-CR-0867
[AD34] PACS DECMEC ICD update	H-P-ASP-CR-0885
[AD35] RW dissipation update	H-P-TN-AI-0131
[AD36] CRS EEPROM ALERT SVM PM#33	H-P-ASP-MN-7345, AI#7
[AD37] Heaters and thermistors description and layout	H-P-TN-AI-0069
[AD38] SCS/LFI dissipations update	H-P-ASP-CR-0896
[AD39] PLANCK PFM#1 Thermal Test SVM Correlation Report	H-P-RP-AI-0177



2.2 REFERENCE DOCUMENTS

- [RD1] Thermal Conductivity of Metallic Honeycomb Sandwich Panels - NLR, Amsterdam, NL
- [RD2] Analytical/Experimental Semiempirical Evaluation of Spacelab MLI Thermal Conductance RP-AI-0237, dated 13/09/78
- [RD3] Survey and Evaluation of Multilayer Insulation Heat Transfer Measurements J.Doenecke (DASA), 23rd ICES, July 1993 - paper n.SAE 932117
- [RD4] A Systematic Approach to Thermal Balance Test Evaluation and Thermal Mathematical Model Correlation for Spacecraft Thermal Design, L.Costamagna, V.Perotto, E.Sacchi (Alenia Spazio), 4th European Symposium on Space Environmental and Control Systems, October 1991.
- [RD5] H-P-TN-AI-0135 Addendum to HERSCHEL TB/TV Test correlation

2.3 LIST OF ACRONYMS

AAD	: Attitude Anomaly Detector
BOL	: Beginning of Life
EOL	: End of Life
GMM	: Geometrical Mathematical Model
GYRO	: Gyroscope
He Tanks	: Helium Tanks
HPLM	: Herschel Payload Module
H/W	: Hardware
LGA	: Low Gain antenna
MGA	: Medium Gain antenna
MLI	: Multi Layer Insulation
OSR	: Optical Solar Reflector
PPLM	: Planck Payload Module
P.Tanks	: Propellant Tanks
PTSS	: Propellant Tank Support Structure
rpm	: revolution per minute
S/C	: Spacecraft or Satellite
SAS	: Sun Acquisition sensor
SCC	: Sorption Cooler Compressors
STR	: Star Trackers
SVM	: Service Module
TBC	: To Be Confirmed
TBD	: To Be Defined
TMM	: Thermal Mathematical Model
VDA	: Vacuum Deposited Aluminum

3 HERSCHEL MODELS DESCRIPTION

The Geometric Mathematical Model (GMM) of HERSCHEL satellite has been built using Esarad (version 5.3.2) software and it is composed by two models, which describe respectively the internal enclosures of the spacecraft and the external environment of the spacecraft. A reduced model of the Payload Module, furnished by ALCATEL [AD20], has been introduced in the external GMM. Due to the huge distance of the orbit from the Earth, solar, albedo and earth fluxes have been considerate as one global flux in the thermal analysis. An overall view is shown in Figures 3-1 to 3-3.

The Thermal Mathematical Model (TMM) of HERSCHEL has been prepared with Esatan software and contains the thermal node description, the thermal conductivity network and the unit and heater dissipation.

The correlated model has a total of 3933 nodes:

- 1622 in the external geometrical model
- 1338 in the internal geometrical model
- 30 in the PLM reduced model
- 138 in the detailed STR model
- 126 in the detailed Thrusters model
- 679 mathematical nodes

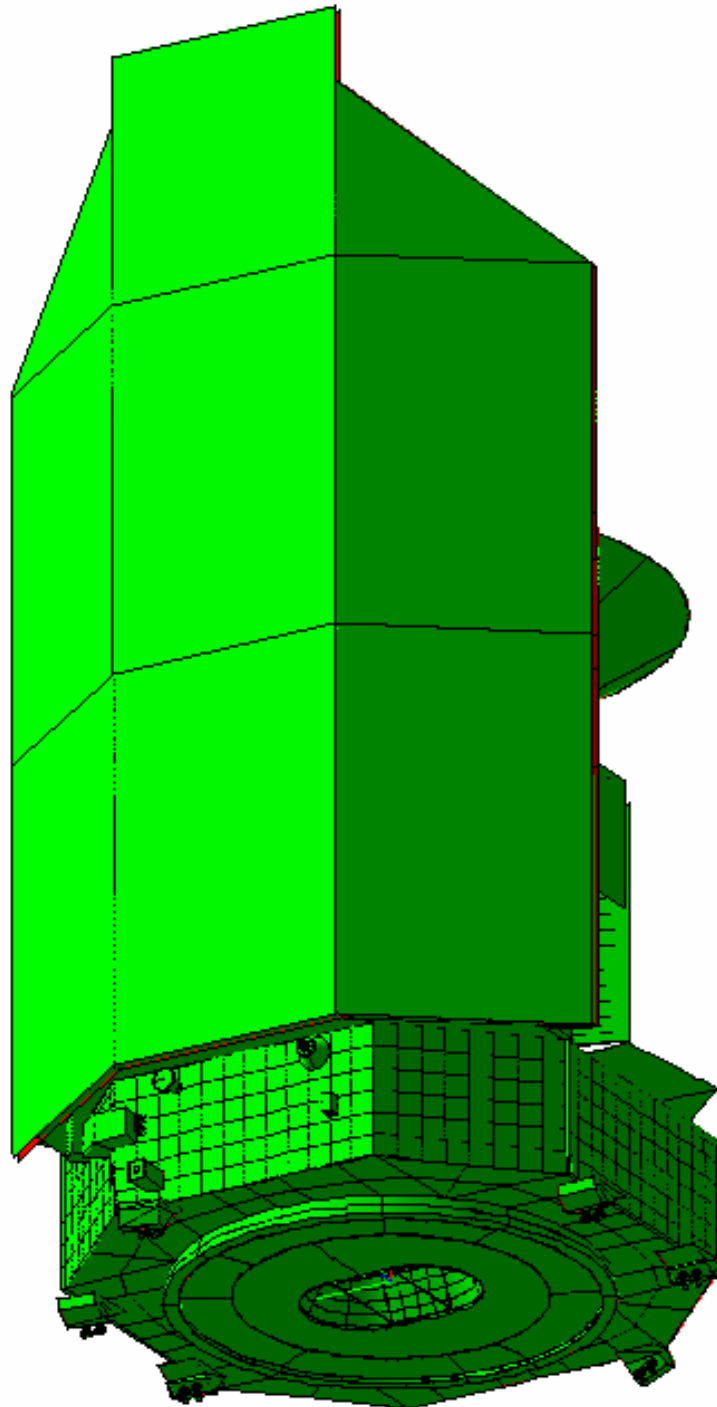

Figure 3-1 HERSCHEL – Overall view +Z



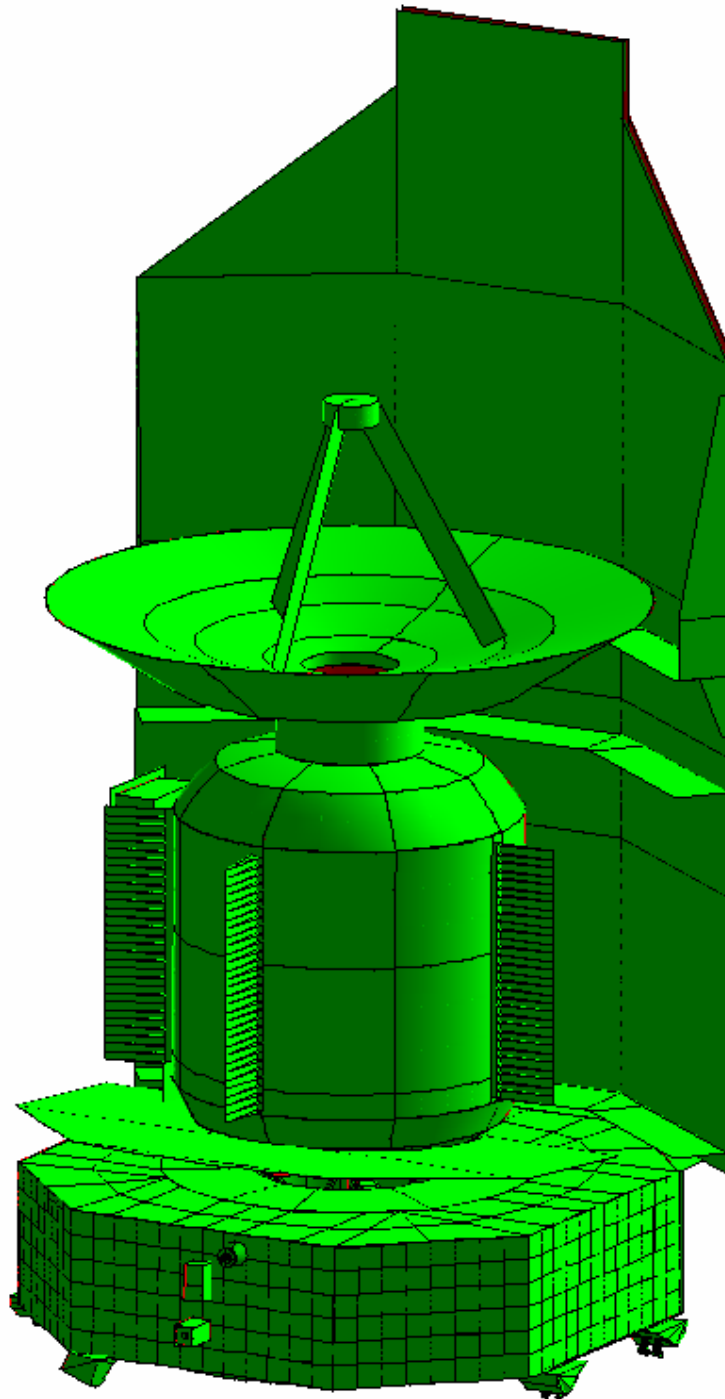

Figure 3-2 HERSCHEL – Overall view -Z



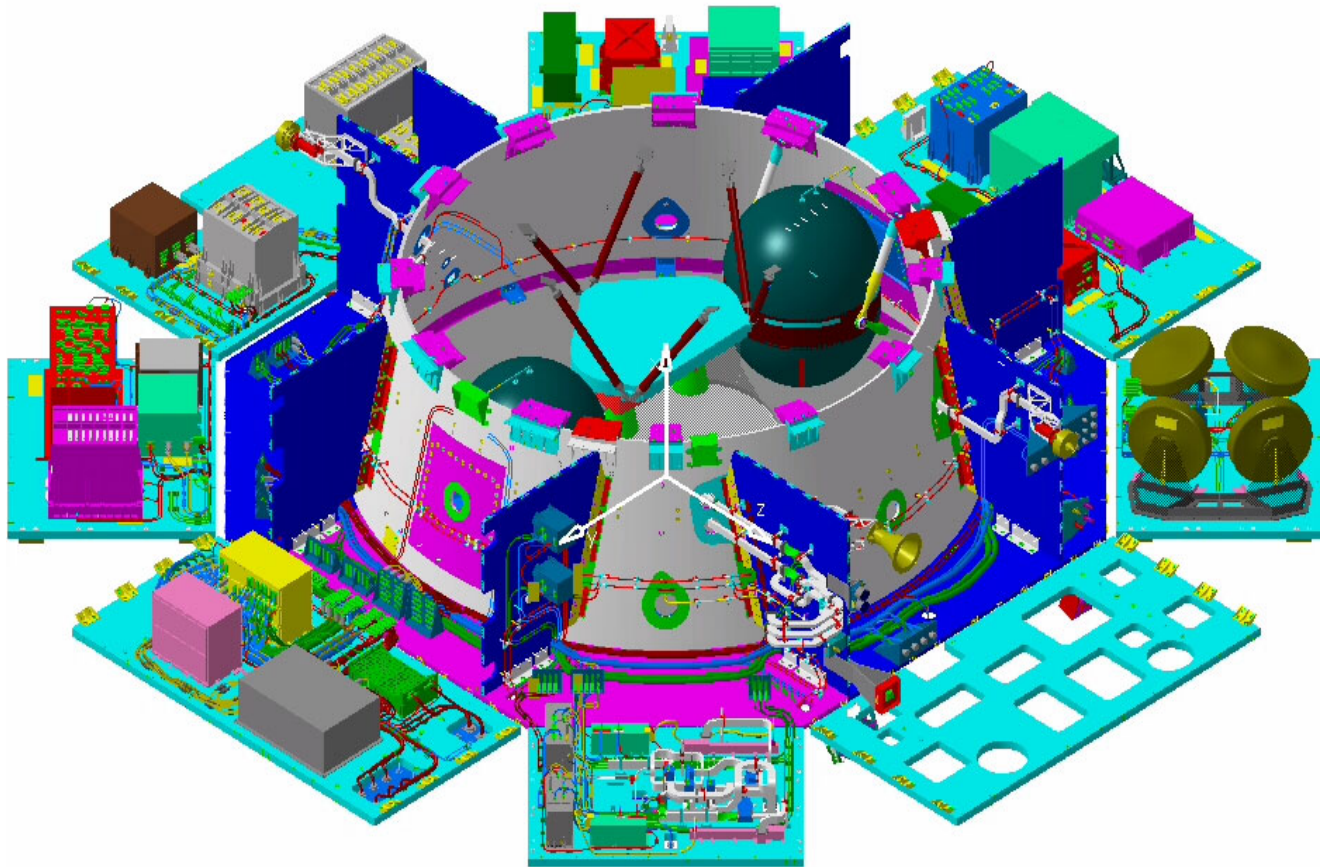

Figure 3-3 HERSCHEL – Internal overall View

3.1. HERSCHEL GMM and TMM update to Flight Configuration

Variations applied to GMM and TMM models due to the TV/TB test campaign and the model correlation activity, already reported in [AD29], are maintained for the Flight Analysis; in the following paragraphs, major modifications coming from the correlation activity will be summarized, and modifications due to the updated Flight Configuration will be highlighted too (reduced radiative area due to the IDB last issue).

3.1.1 HERSCHEL External GMM Variations

Major External GMM modifications are related to external MLI, STR, Thrusters, and the thermal-optical properties measured before the test campaign; for more details see [AD29].

- External MLI layout modifications
A general refinement of the external panels MLI nodes has been performed after TV/TB test campaign also considering the last issue of the HIFI units IDB; a list of the affected nodes is in the following table:

PANEL	AFFECTED NODES	ADDED/NEW NODES	GMM CONFIGURATION	
			Was	is
+Y+Z	4102 4103	-	BLACK MLI flat	BLACK MLI box
	3141 to 3148	4100	OSR	partially covered with BLACK MLI strip
	3108,3116,3124 3132,3140,3148	4106	OSR	partially covered with BLACK MLI strip
	3101,3109,3117 3125,3133,3141	4107	OSR	partially covered with BLACK MLI strip
+Z	4037	4103	BLACK MLI flat	BLACK MLI box to cover the waveguides
+Y-Z	3303	4303	Aeroglaze Z307	BLACK MLI
	3338	4338	Aeroglaze Z307	BLACK MLI
-Z	3415	4415-	Aeroglaze Z307	BLACK MLI
	3423	4423	Aeroglaze Z307	BLACK MLI
	3435	4435	Aeroglaze Z307	BLACK MLI
-Y-Z	4501	4501/3501	BLACK MLI	partially covered with BLACK MLI strip
	3502,3503,3504	4501	Aeroglaze Z307	partially covered with BLACK MLI strip
	3509,3517,3525	4501	Aeroglaze Z307	partially covered with BLACK MLI strip
	3536	4536	Aeroglaze Z307	partially covered with BLACK MLI
	3545	4545	Aeroglaze Z307	partially covered with BLACK MLI
	4541 to 4544 3545 to 3547 4548	4500	BLACK MLI/ Aeroglaze Z307	partially covered with BLACK MLI strip
-Y	3602,3614,3626, 3643,3654,3655	4602,4614,4626, 4643,4654,4655	OSR	BLACK MLI
	3668,3669,3670	4668,4669,4670	OSR	BLACK MLI
	3638	4638	OSR	BLACK MLI
	4661,4662 3663 to 3667	4600	OSR/ BLACK MLI	partially covered with BLACK MLI

Table 3.1.1-1 HERSCHEL – External MLI modifications

Controlled Distribution

A sketch of the updated Flight Configuration of external SVM panels is shown in Figure 3.1.1-1 (the drawing is viewed from +X axis and the panels are viewed from internal side, with the radiative areas projected on the internal panels. The outlining represents the MLI and white colour represents the radiative area), while a summary of the areas used in the current radiator layout is given in Table 3.1.1-2. The detailed MLI layout of the single panels is listed in Figures 3.1.1-2.

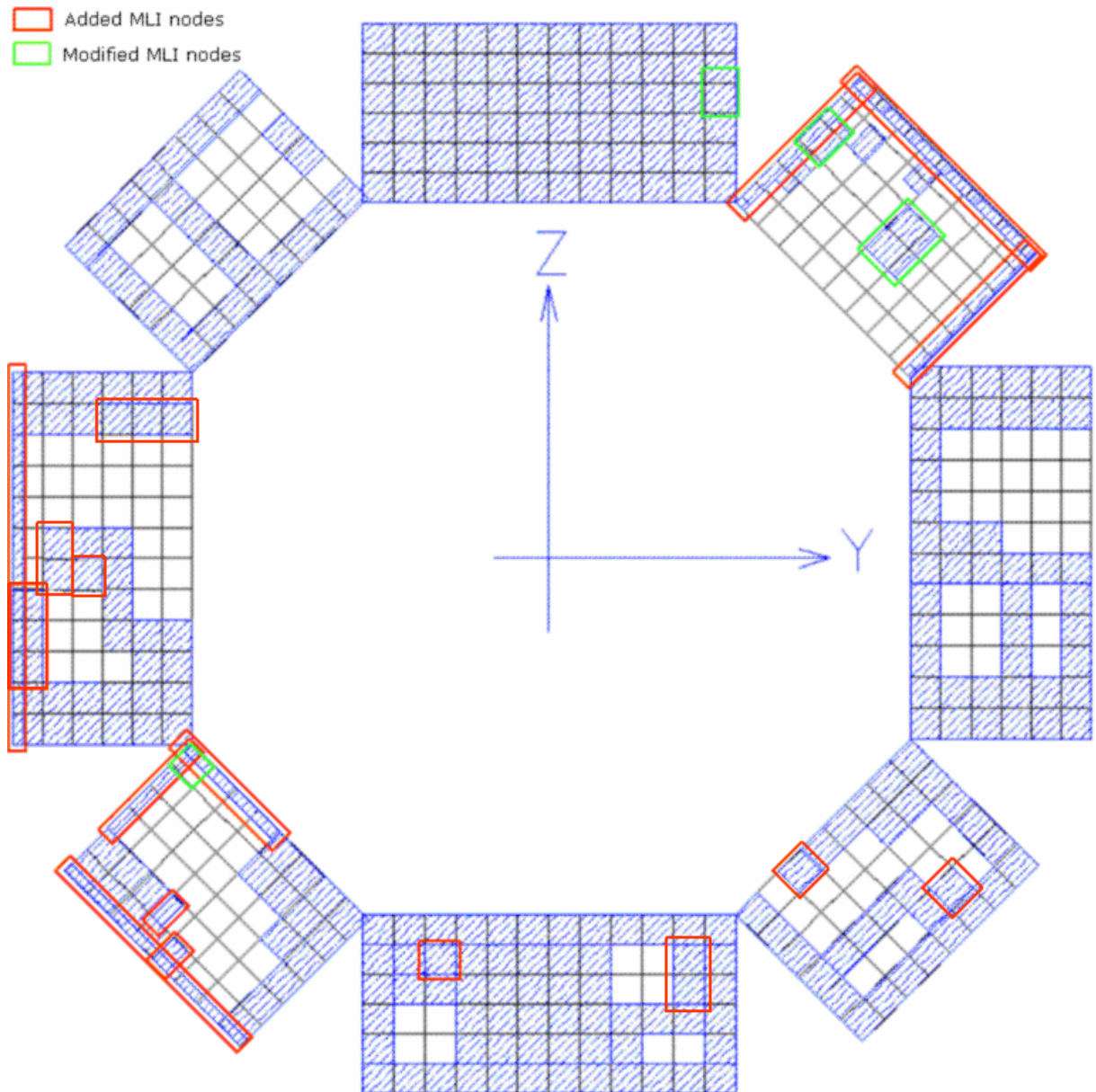

Figure 3.1.1-1 HERSHEL – SVM external panels radiators layout

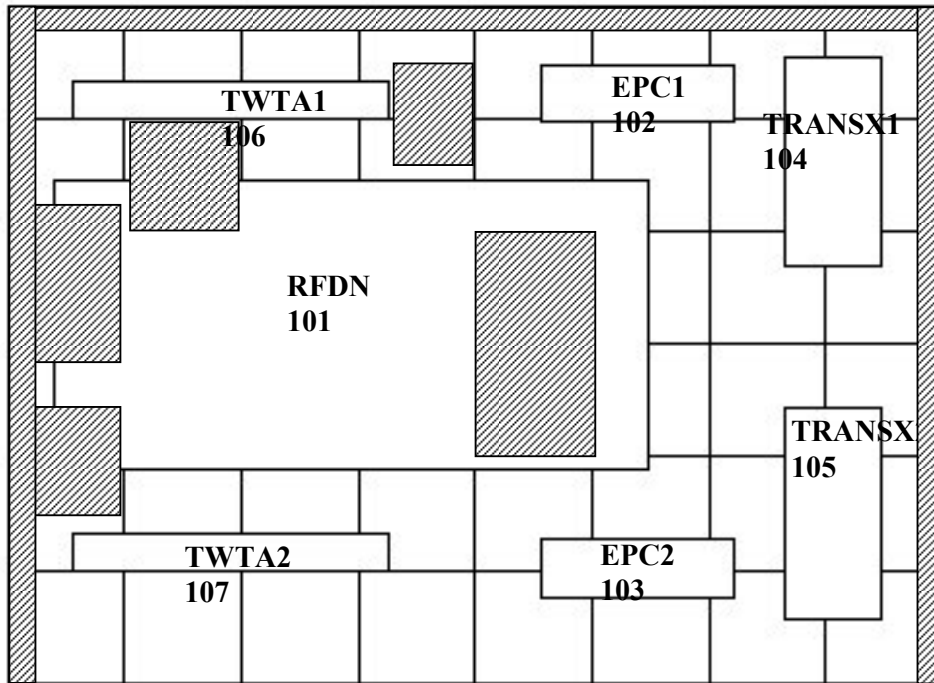

Figure 3.1.1-2a: HERSCHEL - +Y +Z MLI Lateral Panel & Units Internal View (See internal detail below)

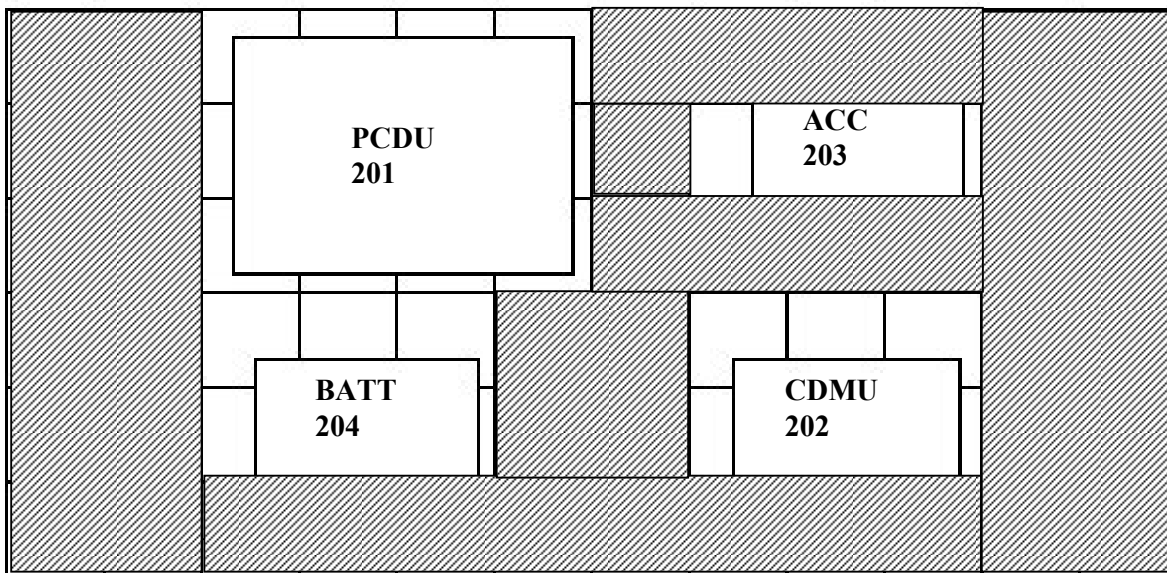

Figure 3.1.1-2b: HERSCHEL - +Y MLI Lateral Panel & Units Internal View

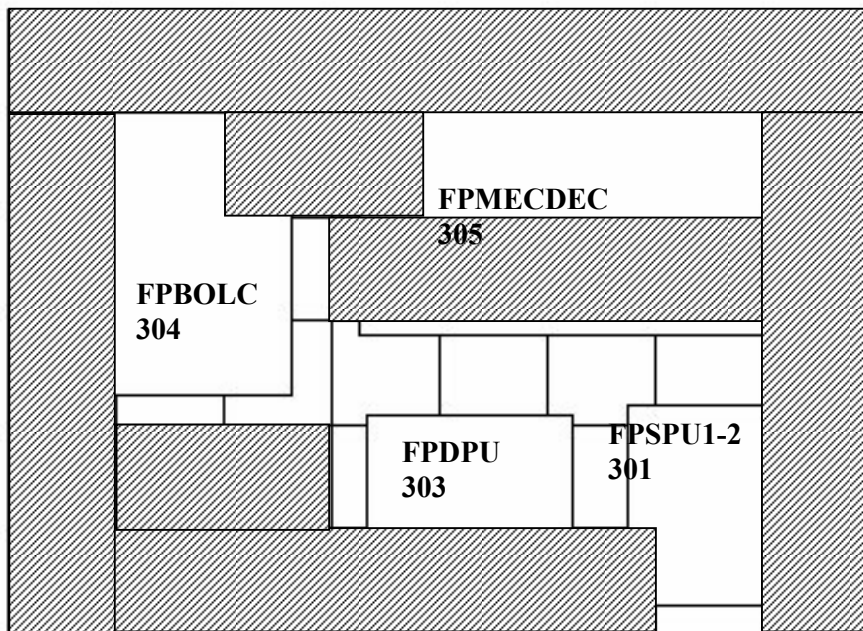

Figure 3.1.1-2c: HERSCHEL - +Y -Z MLI Lateral Panel & Units Internal View



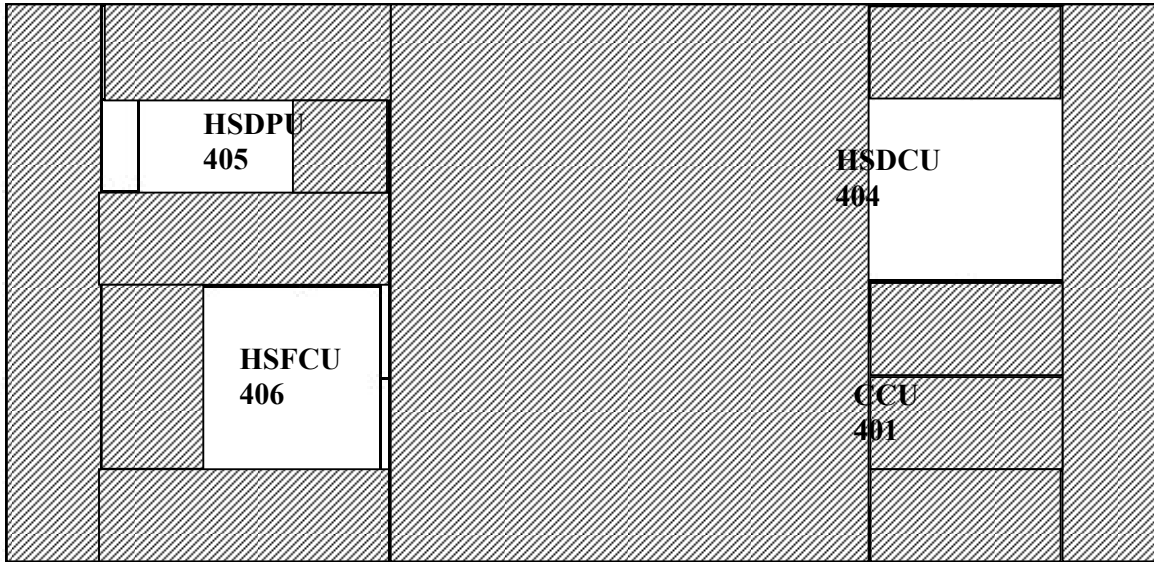

Figure 3.1.1-2d: HERSCHEL - -Z MLI Lateral Panel & Units Internal View

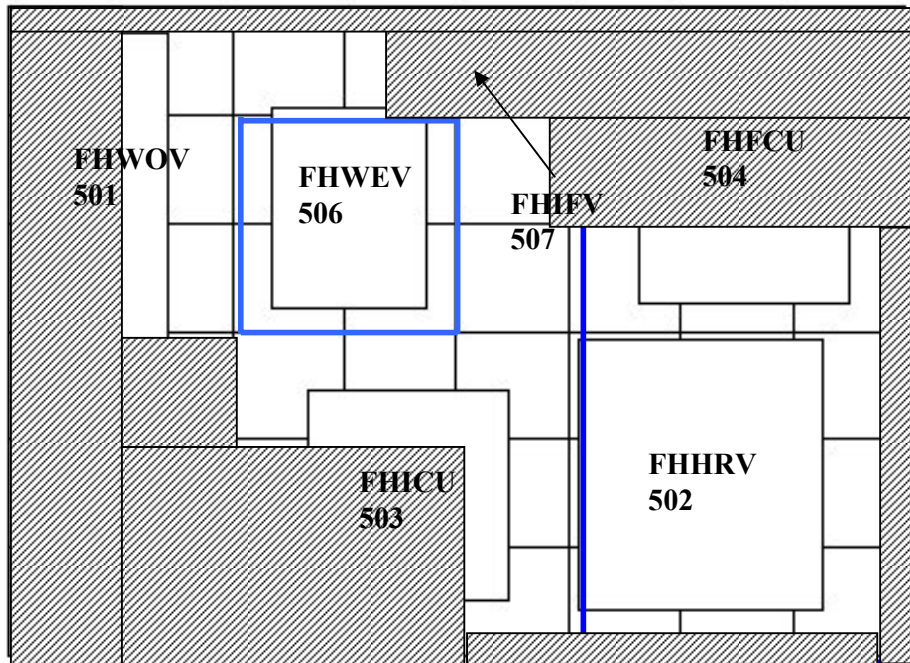

Figure 3.1.1-2e: HERSCHEL - -Y -Z MLI Lateral Panel & Units Internal View after correlation

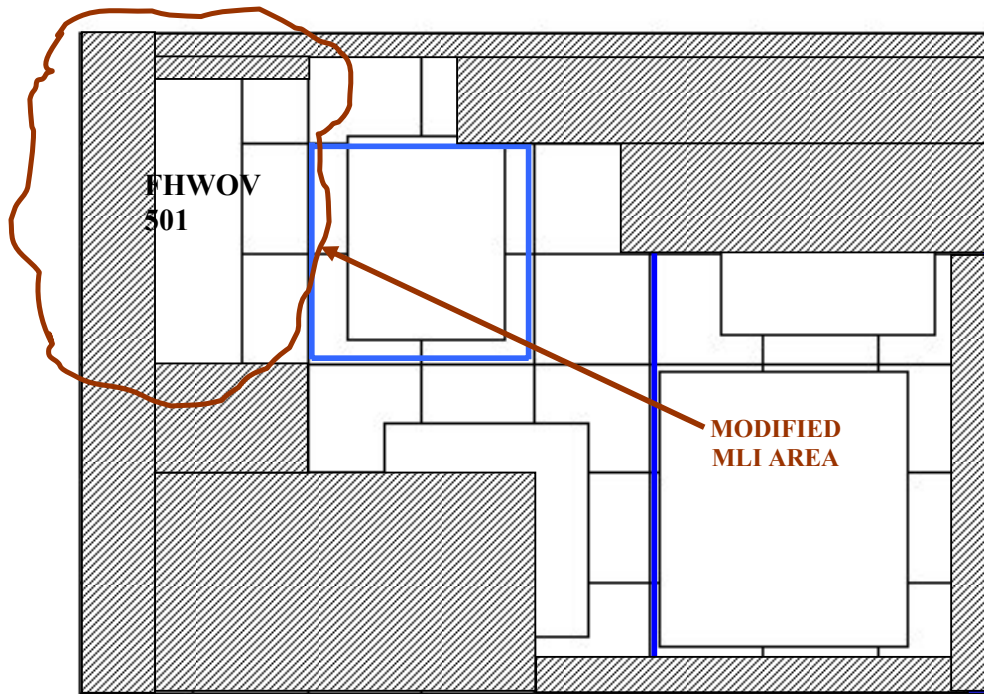

Figure 3.1.1-: HERSHEL - -Y -Z MLI Lateral Panel & Units Internal View according to [AD31]

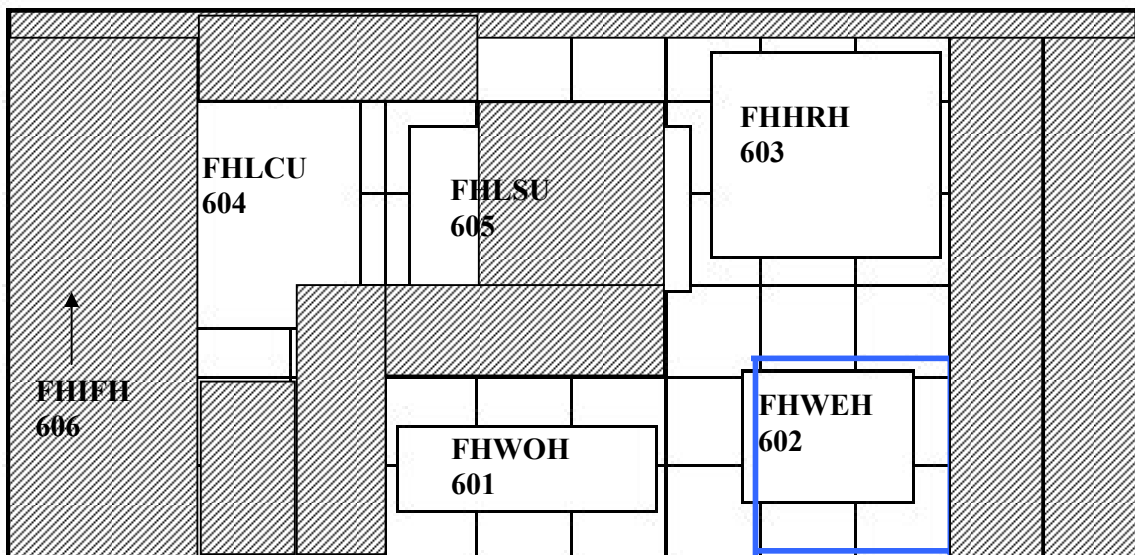

Figure 3.1.1-2f HERSHEL - -Y MLI Lateral Panel & Units Internal View



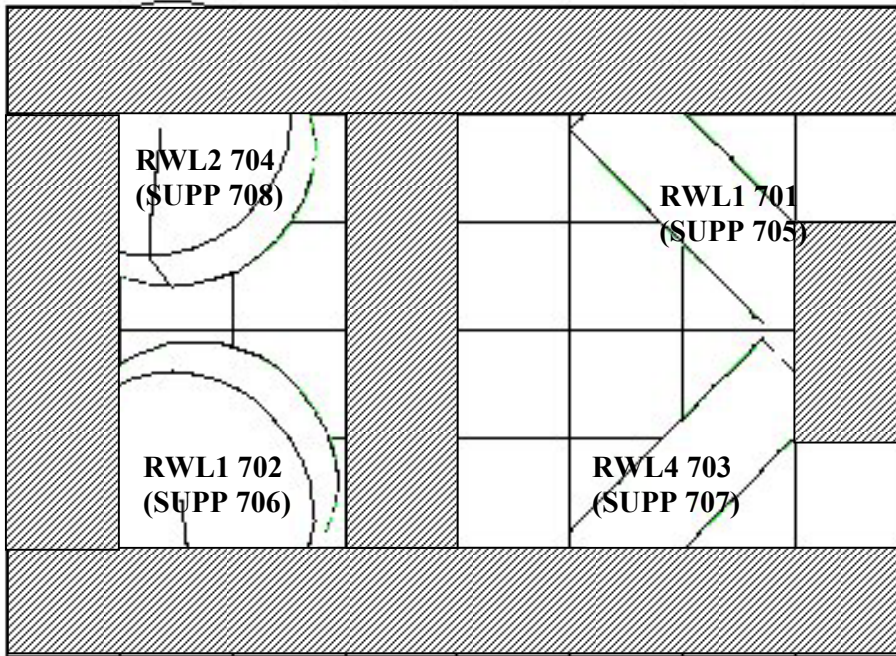

Figure 3.1.1-2g: HERSCHEL - -Y +Z MLI Lateral Panel & Units Internal View

SVM RADIATORS AREAS [m ²]							
CDR				POST TEST STM			
Lateral Panels	Total Area	Radiative area	MLI Area	Lateral Panels	Total Area	Radiative area	MLI Area
+Z	1.462	0.000	1.462	+Z	1.462	0.000	1.462
+Y+Z	0.974	0.869	0.105	+Y+Z	0.974	0.731	0.244
+Y	1.462	0.548	0.914	+Y	1.462	0.548	0.914
+Y-Z	0.974	0.386	0.588	+Y-Z	0.974	0.345	0.626
-Z	1.462	0.264	1.198	-Z	1.462	0.203	1.259
-Y-Z	0.974	0.548	0.426	-Y-Z	0.974	0.505	0.469
-Y	1.462	0.873	0.589	-Y	1.462	0.592	0.870
-Y+Z	0.974	0.447	0.527	-Y+Z	0.974	0.446	0.528
TOTAL	9.744	3.935	5.809	TOTAL	9.744	3.37	6.37

Table 3.1.1-2 HERSCHEL – SVM radiators areas updated post correlation

SVM RADIATORS AREAS [m ²]							
POST TEST STM				POST TEST STM			
Lateral Panels	Total Area	Radiative area	MLI Area	Lateral Panels	Total Area	Radiative area	MLI Area
+Z	1.462	0.000	1.462	+Z	1.462	0.000	1.462
+Y+Z	0.974	0.731	0.244	+Y+Z	0.974	0.731	0.244
+Y	1.462	0.548	0.914	+Y	1.462	0.548	0.914
+Y-Z	0.974	0.345	0.626	+Y-Z	0.974	0.345	0.626
-Z	1.462	0.203	1.259	-Z	1.462	0.203	1.259
-Y-Z	0.974	0.505	0.469	-Y-Z	0.974	0.512	0.462
-Y	1.462	0.592	0.870	-Y	1.462	0.592	0.870
-Y+Z	0.974	0.446	0.528	-Y+Z	0.974	0.446	0.528
TOTAL	9.744	3.37	6.37	TOTAL	9.744	3.38	6.36

Table 3.1.1-2 HERSCHEL – SVM radiators areas updated according to [AD31]

- Thrusters modifications

A more detailed thrusters model has been introduced for the TV/TB test campaign and the related correlation activity; for each of the six thruster groups, a new model composed by the body of the main and the redundant thruster, their support bracket, and the MLI box covering the entire assembly has been build. This local model is shortly described hereafter, as well as the minor GMM modifications introduced for the Flight Configuration. For more details, see [AD29] and the following figures:

GMM NODE NUMBER	LABEL	BOL PROPERTIES		Configuration	
		α	ϵ	TV/TB	FLIGHT
8X01 ^(*)	NOZZLE	0.50	0.35	√	√
8X02 ^(*)	DEC. CHAMBER	0.50	0.70	√	√
8X03 ^(*)	EXT. INSULATION	0.50	0.12	X	√
8X05 ^(*)	HEAT BARRIER DOWN	0.50	0.30	√	√
8X06 ^(*)	HEAT BARRIER MID	0.50	0.30	√	√
8X07 ^(*)	HEAT BARRIER UP	0.50	0.30	√	√
8X08 ^(*)	HEAT BARR. FLANGE	0.50	0.30	√	√
8X09 ^(*)	FCV FLANGE I/F	0.50	0.30	√	√
8X10 ^(*)	ADJUSTMENT RING	0.50	0.60	√	√
8X11 ^(*)	TURNING DISC	0.50	0.60	√	√
8X35 ^(*)	HEATERS ELECTR. CONNECT.	0.50	0.60	√	√
8X36 ^(*)	HEATERS ELECTR. CONNECT.	0.50	0.60	√	√
8X37 ^(*)	HEATERS ELECTR. CONNECT.	0.50	0.60	√	√
8X38 ^(*)	HEATERS ELECTR. CONNECT.	0.50	0.60	√	√
8X43 ^(*)	DEC. CHAMBER HEATER	0.50	0.70	√	√
8X44 ^(*)	DEC. CHAMBER HEATER	0.50	0.70	√	√
8X32	SUPPORT BRACKET	0.40	0.20	√	√
8X33	FCV BODY, MAIN	0.50	0.60	√	√
8X34	FCV BODY, REDUNDANT	0.50	0.60	√	√
8X46	EXT MLI BOX	0.92	0.86	√	√
8X47	INT MLI BOX	0.13	0.05	√	√

^(*) node numbering for main thruster; add 20 for redundant thruster

Table 3.1.1-3 HERSCHEL – Thrusters GMM

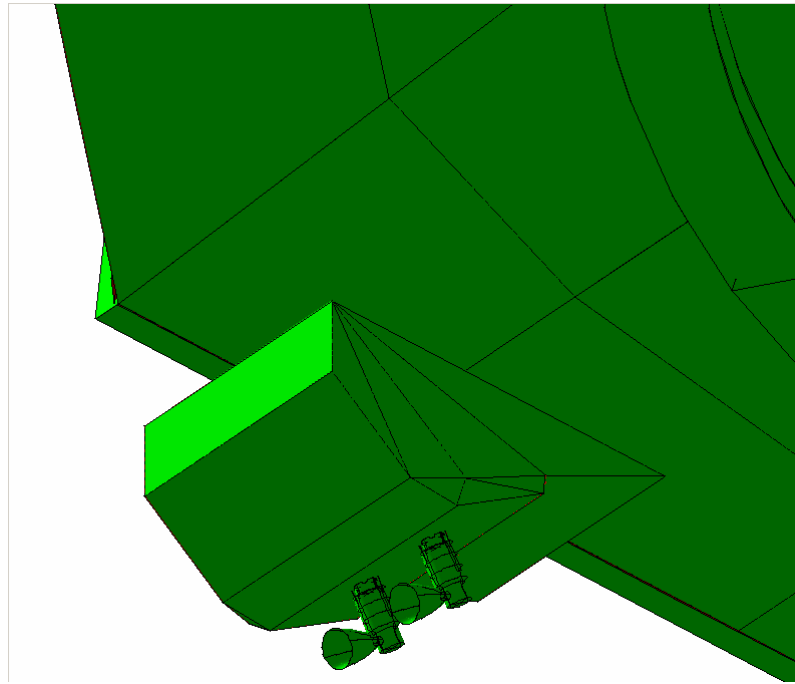

Figure 3.1.1-3 HERSCHEL – Thruster external view, Flight Configuration without external insulators

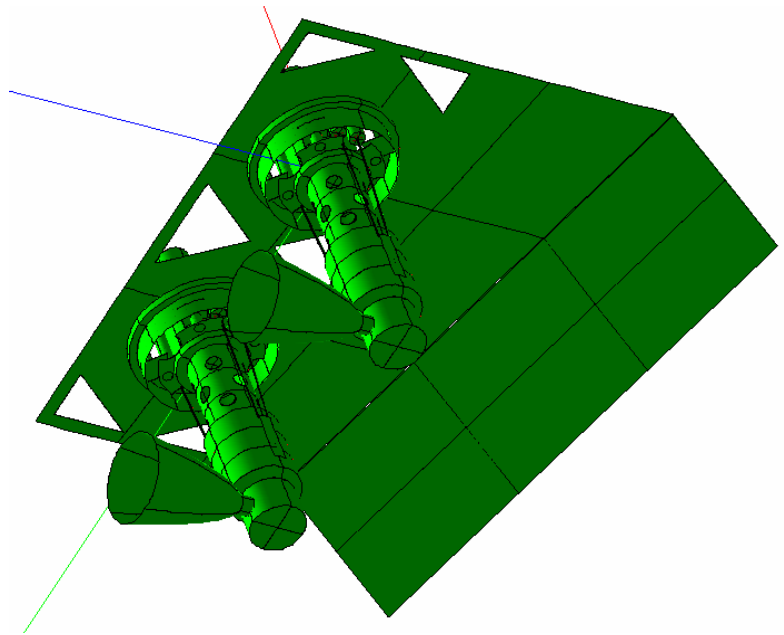

Figure 3.1.1-4 HERSCHEL – Thruster external view, TV/TB Configuration without external insulators

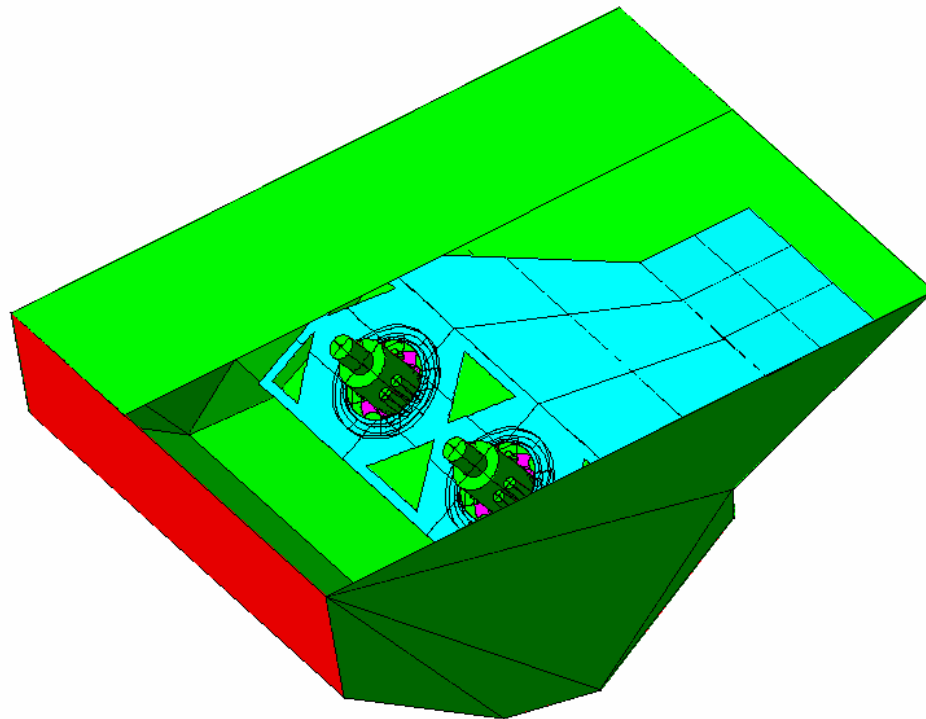

Figure 3.1.1-5 HERSCHEL – Thruster internal view

Controlled Distribution

- Thermal-optical Properties
The thermal-optical properties of external surfaces in the GMM have been modified after a measurement campaign, according to [AD30] and [AD29]; modifications due to the update to the Flight Configuration and due to the HIFI IDB last issue, are highlighted in the Table 3.1.1-4.

The last updating (from issue 05) is highlighted in blue and it is due to the Change Request [AD33]

SURFACES	MATERIALS	α BOL	α EOL	ϵ	Reference
GMM INTERNAL					
Units, Internal panels	Aeroglaze Z306			0.87	ALS
Internal Panels -Y-Z, -Y	Aluminium			0.05	ALS
FPDPU/HSDPU	Black Anodized			0.86	H-P-ASP-CR-0867
FHICU				0.85	HIFI IIDB 3.3
FHFCU				0.91	HIFI IIDB 3.3
FHLSU				0.87	HIFI IIDB 3.3
Battery				0.30	Average ϵ value
CCU	Alodine			0.2	ICD Data (AD9)
FHWOV/FHWOH	Aluminium			0.05	ALS
HRV/WEV/WEH/HRH/LCU	Black paint			0.8	ICD Data (AD9)
FH3DV/FH3DH	Goldized			0.05	ICD Data (AD9)
LV1/LV2/LF	Aluminium Tape (titanium)			0.05	ALS
PT	Aluminium Tape (steel)			0.05	ALS
FHWIH IF cables	Kapton Tape			0.7	ALS assumption
CFRP Surfaces (Bottom Floor, Top Floor, Shear Panels & Cone)	CFRP			0.87	ALS
Internal Launcher Adaptor Ring	Aluminium Tape			0.05	ALS
Internal MLI (-Y Panel, -Y-Z Panel, Internal STR baffle, Tanks)	VDA Kapton (Aluminized)			0.05	ALS
Bottom closure internal side	1/3 CFRP - 2/3 VDA Kapton (Aluminized)			0.33	Average ϵ value
GMM EXTERNAL					
VMC lens		0.9	=	0.9	ALS Assumption
SREM		0.52	=	0.12	Integral data
SAS housing/pyramid		0.96	=	0.83	HP-4-TNO-RP-S004
SAS chip		0.9	=	0.82	HP-4-TNO-RP-S004
MGA / LGA	Alodine 1200 S	0.46	=	0.1	HP-AN-RY-0020-21
MGA	Germanium	0.6	=	0.72	HP-AN-RY-0021
LGA	White paint	0.6	=	0.88	HP-AN-RY-0020
AAD top surface		0.96	=	0.83	HP-4-TNO-RP-A004
AAD chip		0.9	=	0.013	HP-4-TNO-RP-A004
External Launcher Adaptor Cone	Cromic Acid/Aluminium	0.218	=	0.066	Test Measurement
External Launcher Adaptor Edge	Alodine/Aluminium	0.220	=	0.066	Test Measurement
Alodine		0.56	=	0.16	Test Measurement
Chofoil		0.11	=	0.03	Test Measurement
Cromic Acid					Test Measurement
Lat Panels +Y+Z, +Y, -Y, -Y+Z, STR	OSR	0.1	0.18	0.82	Test Measurement
Others Lat Panels	Aeroglaze Z307	0.97	=	0.88	Test Measurement

SURFACES	MATERIALS	α BOL	α EOL	ϵ	Reference
MLI to HPLM and MLI truss to CVV	VDA Kapton (Aluminized)	0.15	=	0.05	ALS
External STR secondary baffle	Silver Teflon Tape	0.04	0.24	0.80	Specularity=65% Test Measurement
External MLI (Bottom Floor, Launcher Adaptor, Radiator Panels, External units, STR radiator unit and baffle)	Carbon Filled Kapton	0.94	=	0.85	Test Measurement

Table 3.1.1-4 HERSCHEL – SVM thermal-optical properties

3.1.2 HERSCHEL Internal GMM Variations

Major Internal GMM modifications are related to HIFI Panels and TT&C Panel and units:

- HIFI Panels modifications**
 Both for HIFI Short Panel and for HIFI Long Panel, GMM has been modified introducing an increased detail near FHWOH and FHWOV respectively; Table 3.1.2-1 provides the new node numbering, while in Figures 3.1.2-1 and 3.1.2-2 a detail of the new mesh is shown.

PANEL	UNIT	PANEL NODES ^(*)		UNIT NODES	
		was	is	was	is
SHORT	FHWOV	X523	X52301 to X52316	1 node more split according to H-P-ASP-CR-0865	
		X531	X53101 to X53116	501: case 521: baseplate	501: MLI 521: baseplate 531: case
		X532	X53201 to X53216		
		X539	X53901 to X53916		
		X540	X54001 to X54016		
		X547	X54701 to X54716		
X548	X54801 to X54816				
LONG	FHWOH	X606	X60601 to X60616	601: case 621: baseplate	601: MLI 621: baseplate 631: case
		X607	X60701 to X60716		
		X608	X60801 to X60816		
		X618	X61801 to X61816		
		X619	X61901 to X61916		
		X620	X62001 to X62016		

^(*) Node numbering: X=6 for internal nodes, X=3 for external nodes

Table 3.1.2-1 HERSCHEL – HIFI Panels GMM

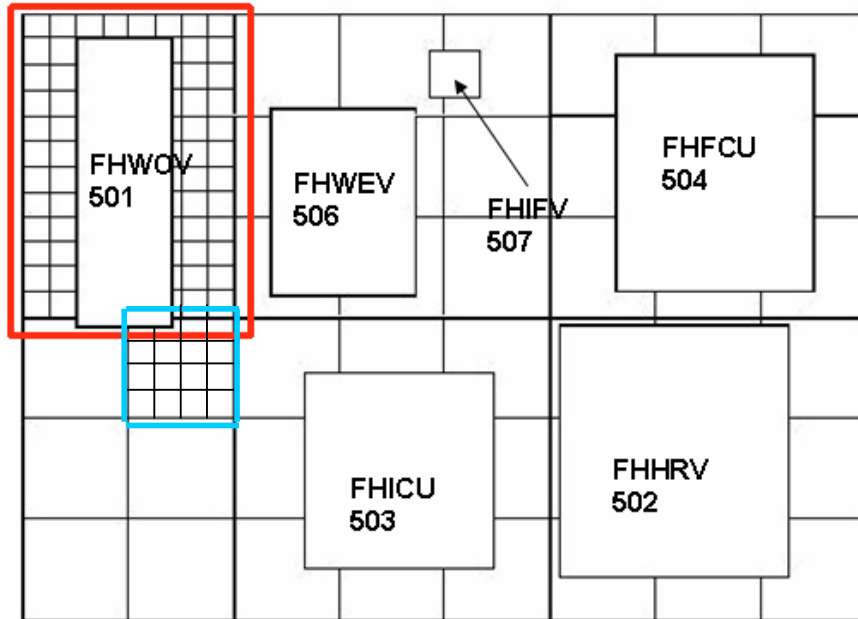

Figure 3.1.2-1 HERSCHEL – HIFI Short Panel new local mesh according to [AD31] in blue

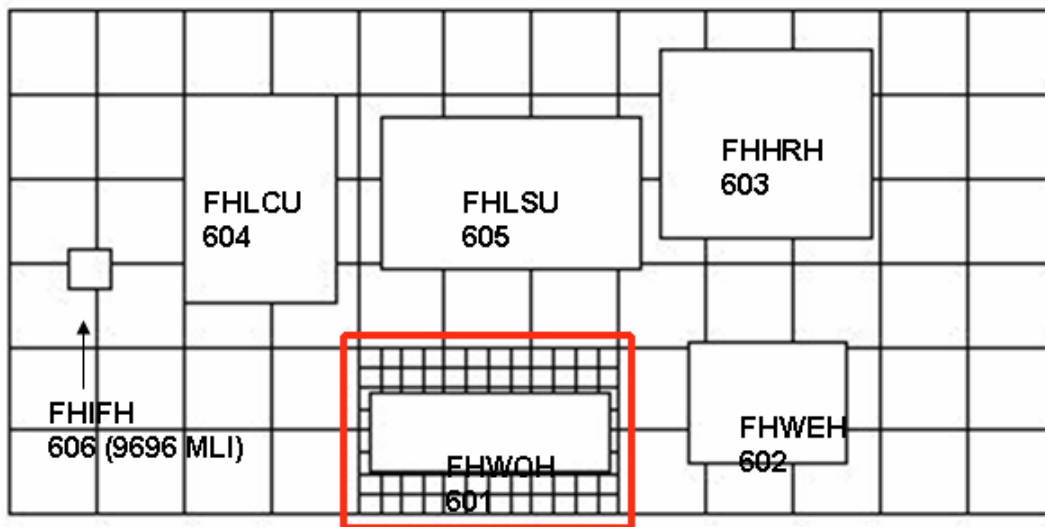

Figure 3.1.2-2 HERSCHEL – HIFI Long Panel new local mesh

A dedicated calculation of radiative coupling between the new mesh nodes and the unit baseplates has been performed; a sketch of the old and the new models of FHWOV and FHWOV is depicted in Figures 3.1.2-3 and 3.1.2-4:

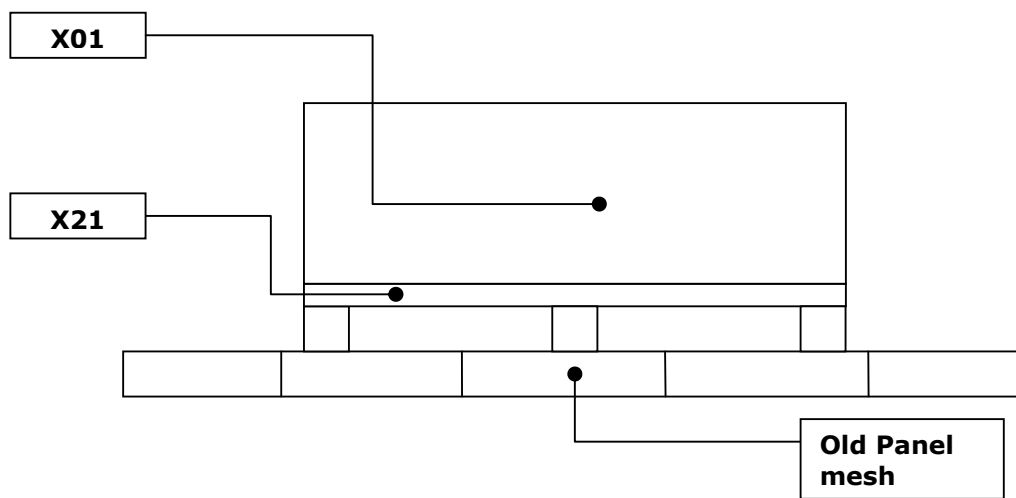

Figure 3.1.2-3 HERSCHEL – FHWOV/FHWOH old model

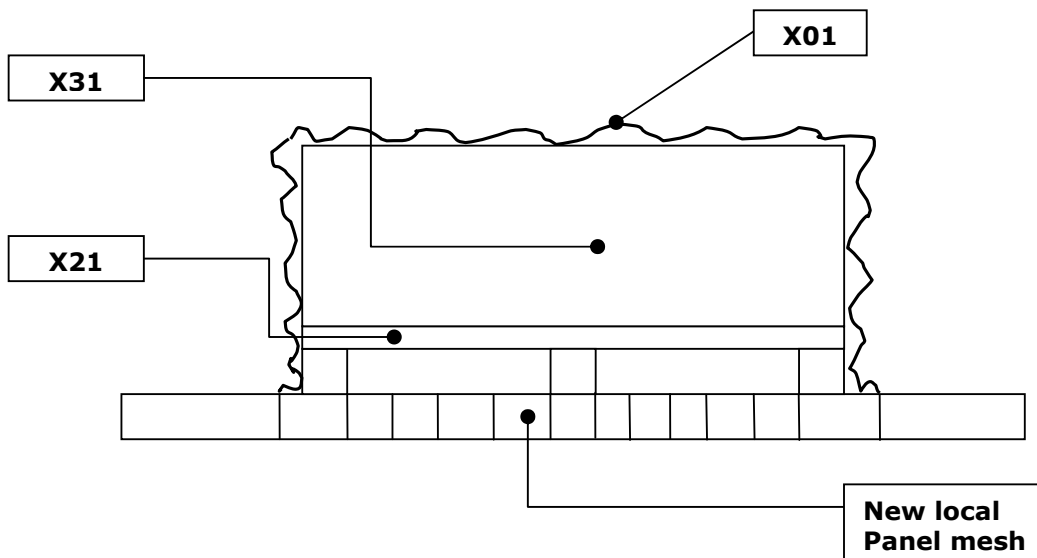

Figure 3.1.2-4 HERSCHEL – FHWOV/FHWOH new model

- TWT Unit and doubler modifications

The TWT and TWT doubler GMM, have been modified introducing an increased detail on TWT doubler and unit; Table 3.1.2-2 provides the new node numbering, while in Figures 3.1.2-5 and 3.1.2-6 a detail of the new mesh is shown.

PANEL	UNIT	DOUBLER NODES		UNIT NODES	
		was	is	was	is
+Y +Z	TWT1	6149 to 6151	6149 to 6151 & 6161 to 6167	106: case	136: HEAD case 146: HEAD baseplate 106: BODY case 126: BODY baseplate
+Y +Z	TWT2	6152 to 6154	6152 to 6160 & 6168	107 case	137: HEAD case 147: HEAD baseplate 107: BODY case 127: BODY baseplate

Table 3.1.2-2 HERSCHEL – TWT Panel and units GMM remodelisation

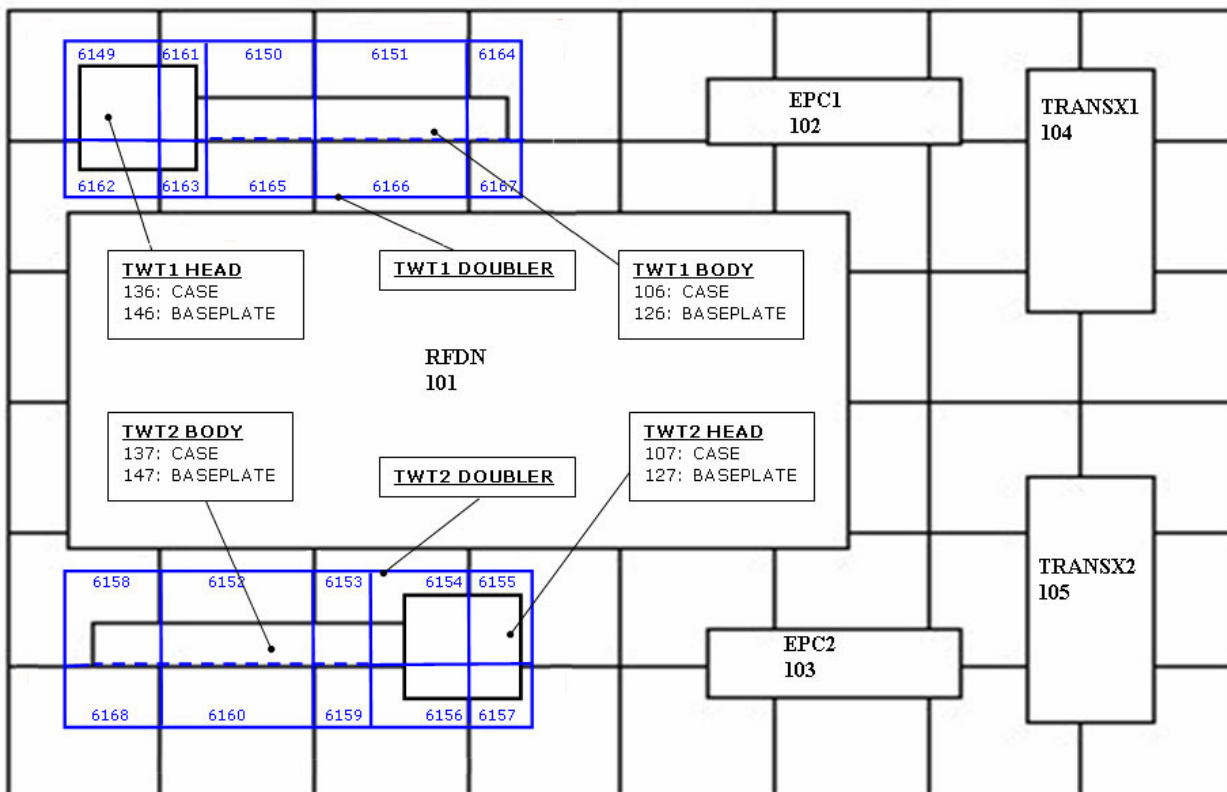

Figure 3.1.2-5 HERSHEL – TT&C doublers new local mesh

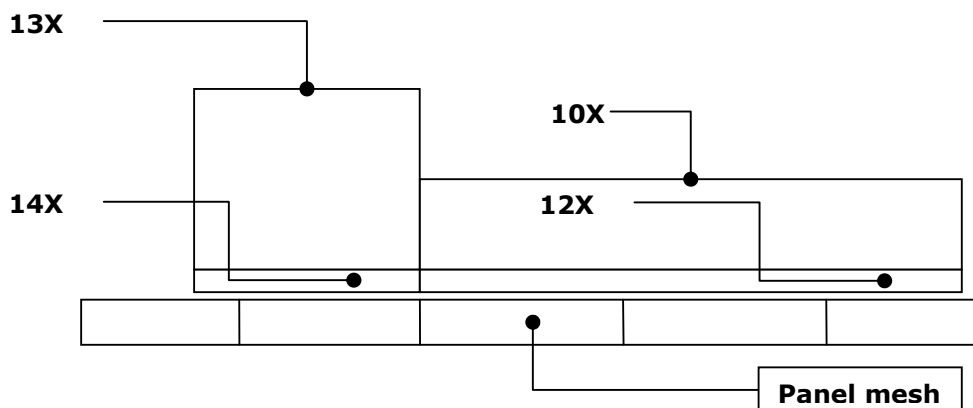

Figure 3.1.2-6 HERSHEL – TWT1 (X=6) / TWT2 (X=7) new model

3.1.3 HERSCHEL TMM Variations

Major TMM modifications described in [AD29] are related to HIFI and TT&C Panels and units and to thrusters:

- HIFI Panels and Units modifications
Accordingly to modifications described in Par. 3.1.2, a general update of the conductive couplings has been performed, mainly regarding FHWOV/FHWOH units and underlying panel nodes (see Figures 3.1.2-3 and 3.1.2-4). The current status is presented in Table 3.1.3-1:

PANEL	UNIT	UNIT-PANEL COUPLINGS			UNIT CONDUCTORS [W/K]	
		was	is	GL [W/K]	was	is
SHORT	FHWOV	521, 6531	521, 653102	0.071	(521, 501) = 9.88	(531, 521) = 9.88 (531, 501) = 0.01936
		521, 6540	521, 654008	0.071		
		521, 6547	521, 654710	0.071		
LONG	FHWOH	621, 6607	621, 660706	0.071	(621, 601) = 9.88	(631, 621) = 9.88 (631, 601) = 0.01936
		621, 6618	621, 661810	0.071		
		621, 6620	621, 662011	0.071		

Table 3.1.3-1 HERSCHEL – HIFI Panels TMM after correlation

PANEL	UNIT	UNIT-PANEL COUPLINGS		UNIT CONDUCTORS GL [W/K]	
		was	is	was	is
SHORT	FHWOV	521, 653102	521, 652314	0.071	0.01
		521, 654008	521, 654710	0.071	0.01
		521, 654710	521, 654007	0.071	0.30
LONG	FHWOH	621, 660706	621, 660706	0.071	0.30
		621, 661810	621, 661809	0.071	0.01
		621, 662011	621, 662012	0.071	0.01

Table 3.1.3-1 HERSCHEL – HIFI Panels TMM according to [AD31]

Controlled Distribution

- TT&C Panels and Units modifications

Accordingly to modifications described in Par. 3.1.2, a general update of the conductive couplings has been performed, mainly regarding TWT units and underlying panel nodes (see Figures 3.1.2-5 and 3.1.2-6). The current status is presented in Table 3.1.3-2:

PANEL	UNIT	UNIT-PANEL COUPLINGS			UNIT CONDUCTORS [W/K]	
		was	is	GL [W/K]	was	is
+Y+Z	TWT1	106, 6149, 6150, 6151	126, 6150, 6151,6164, 6165,6166, 6167	6.09/2	Only one node	(126, 146) = 1.6 (106, 126) = 35 (136, 146) = 35
			146, 6149, 6161,6162, 6163	6.09/2		
	TWT2	107, 6152, 6153, 6154	127, 6158, 6152,6153, 6168,6160, 6159	6.09/2	Only one node	(127, 147) = 1.6 (107, 127) = 35 (137, 147) = 35
			147, 6154, 6155,6156, 6157	6.09/2		

Table 3.1.3-2 HERSCHEL – TT&C Panels TMM

- Thrusters modifications

The thermal model of the thrusters is the same used for XMM and INTEGRAL programs, and it is unchanged; the nodal breakdown is shown in Table 3.1.3-2, while in Table 3.1.3-3 is reported the current status of thruster support brackets-bottom floor coupling.

TMM NODE NUMBER	LABEL	MATERIAL	Configuration	
			TV/TB	FLIGHT
8X01 ^(*)	NOZZLE	HAYNES 25	√	√
8X02 ^(*)	DEC. CHAMBER	STAINL. STEEL	√	√
8X03 ^(*)	EXT. INSULATOR	STAINL. STEEL	X	√
8X04 ^(*)	HEAD PLATE	HAYNES 25	X	√
8X05 ^(*)	HEAT BARRIER DOWN	HAYNES 25	√	√
8X06 ^(*)	HEAT BARRIER MID	HAYNES 25	√	√
8X07 ^(*)	HEAT BARRIER UP	HAYNES 25	√	√
8X08 ^(*)	HEAT BARR. FLANGE	HAYNES 25	√	√
8X09 ^(*)	FCV FLANGE I/F	STAINL. STEEL	√	√
8X10 ^(*)	ADJUSTMENT RING	STAINL. STEEL	√	√
8X11 ^(*)	TURNING DISC	STAINL. STEEL	√	√
8X35 ^(*)	HEATERS ELECTR. CONNECT.	STAINL. STEEL	√	√
8X36 ^(*)	HEATERS ELECTR. CONNECT.	STAINL. STEEL	√	√
8X37 ^(*)	HEATERS ELECTR. CONNECT.	STAINL. STEEL	√	√
8X38 ^(*)	HEATERS ELECTR. CONNECT.	STAINL. STEEL	√	√
8X43 ^(*)	DEC. CHAMBER HEATER	KAPTON	√	√
8X44 ^(*)	DEC. CHAMBER HEATER	KAPTON	√	√
8X32	SUPPORT BRACKET	STAINL. STEEL	√	√
8X33	FCV BODY, MAIN	STAINL. STEEL	√	√
8X34	FCV BODY, REDUNDANT	STAINL. STEEL	√	√
8X46	EXT MLI BOX	MLI 20 LAYER	√	√
8X47	INT MLI BOX	MLI 20 LAYER	√	√

^(*) node numbering for main thruster; add 20 for redundant thruster

Table 3.1.3-3 HERSCHEL – Thrusters TMM

THRUSTER	Bracket Node	Bottom Floor Node	GL [W/K]
A1	8132	1608	0.8
		1612	0.8
A2	8432	1654	1.6
C1	8332	1628	1.6
C2	8232	1622	1.6
C3	8632	1668	1.6
C4	8532	1662	1.6

Table 3.1.3-4 HERSCHEL – Thrusters brackets/Bottom Floor linear couplings

Controlled Distribution

All the thrusters have now 4 copper straps, the design is the same for the six couple of thrusters.

- MLI conductivity modifications

See para 5.1.

- Panel conductivity modifications

See para 5.3

- Unit – Panel conductivity modifications

See para 3.1.7

3.1.4 HERSCHEL RCS Model Variations

A new RCS pipelines model has been introduced for TV/TB Test; it is made of 140 nodes (132 for piping, 4 for RCS units and 4 for the MLI on the RCS units). Each typical pipeline node is centered on the relevant pipeline support; a summary of linear and radiative couplings to structure is given in Table 3.1.4-1. In particular for the units, the grounding design has been modified to reduce the linear conductors vs the structure nodes.

Linear Coupling	RCS Nodes	GL [W/K]	remarks
Single RCS line / Structure	1400 to 1599	0.004	Local variations for nodes near +Z valves and shear panels
Double RCS Line / Structure		0.007	
RCS line / tanks		0.007	
RCS line / Thrusters FCV		0.01	
LV / -Z+Y shear panel	1477, 1482	0.0428	
LF / -Z+Y shear panel	1400	0.0193	
PT / -Z+Y shear panel	1487	0.0317	
Radiative Coupling	RCS Nodes	GR [W/K ⁴]	remarks
Single RCS line, 20 cm / Structure	1400 to 1599	2.49E-11	Local variations for nodes near tanks
Single RCS line, 30 cm / Structure		3.74E-11	
Single RCS line, 45 cm / Structure		5.80E-11	
Double RCS line, 20 cm / Structure		4.98E-11	
Double RCS line, 30 cm / Structure		7.48E-11	

Table 3.1.4-1 HERSCHEL – RCS model summary

Controlled Distribution

REFERENCE : H-P-RP-AI-0040

DATE : 29/SEP/06

ISSUE : 06

Page : 41/405

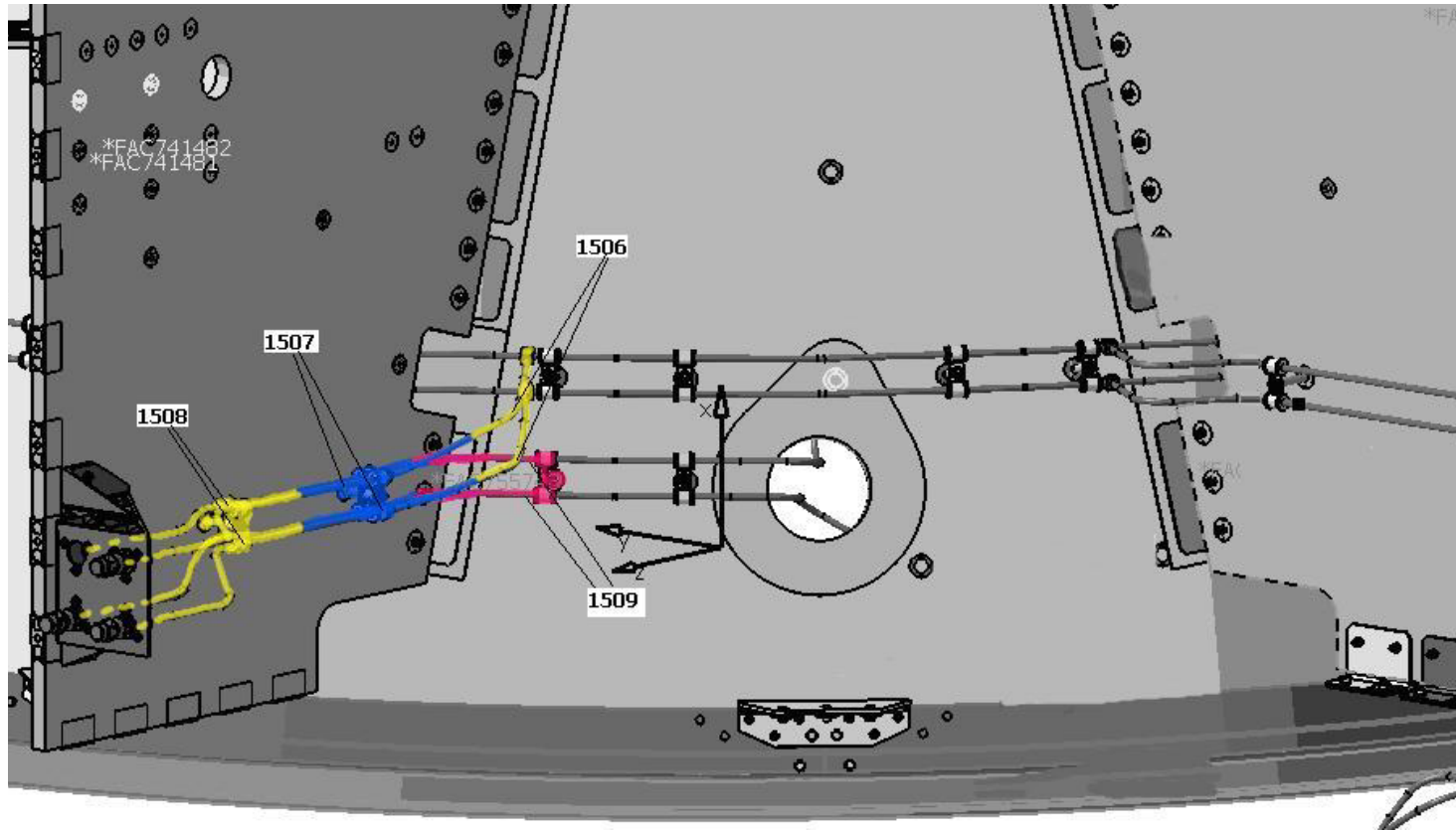

Figure 3.1.4-2 HERSCHEL – RCS line9



Controlled Distribution

REFERENCE : H-P-RP-AI-0040

DATE : 29/SEP/06

ISSUE : 06

Page : 42/405

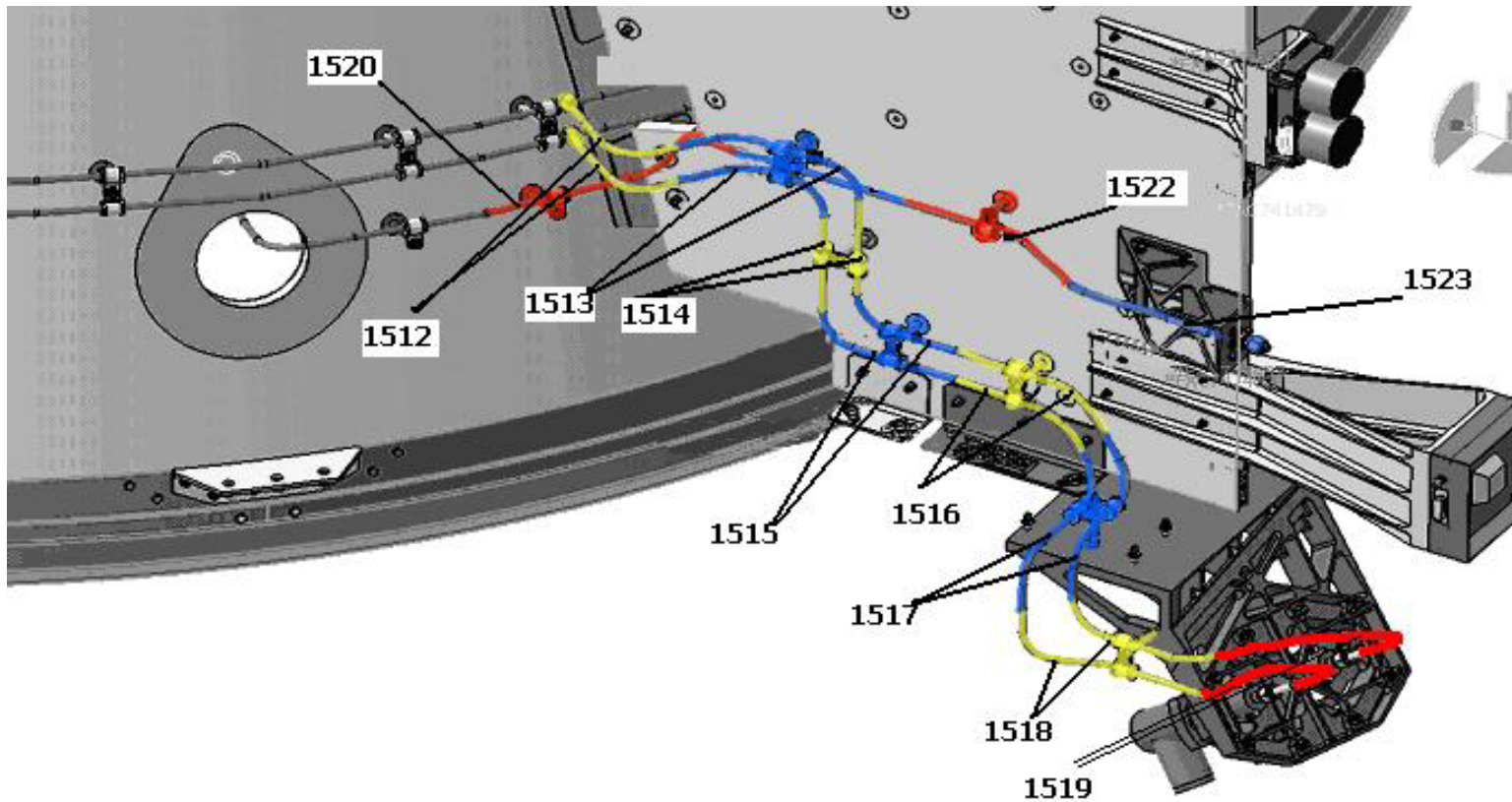

Figure 3.1.4-3 HERSHEL – RCS line9



Controlled Distribution

REFERENCE : H-P-RP-AI-0040

DATE : 29/SEP/06

ISSUE : 06

Page : 43/405

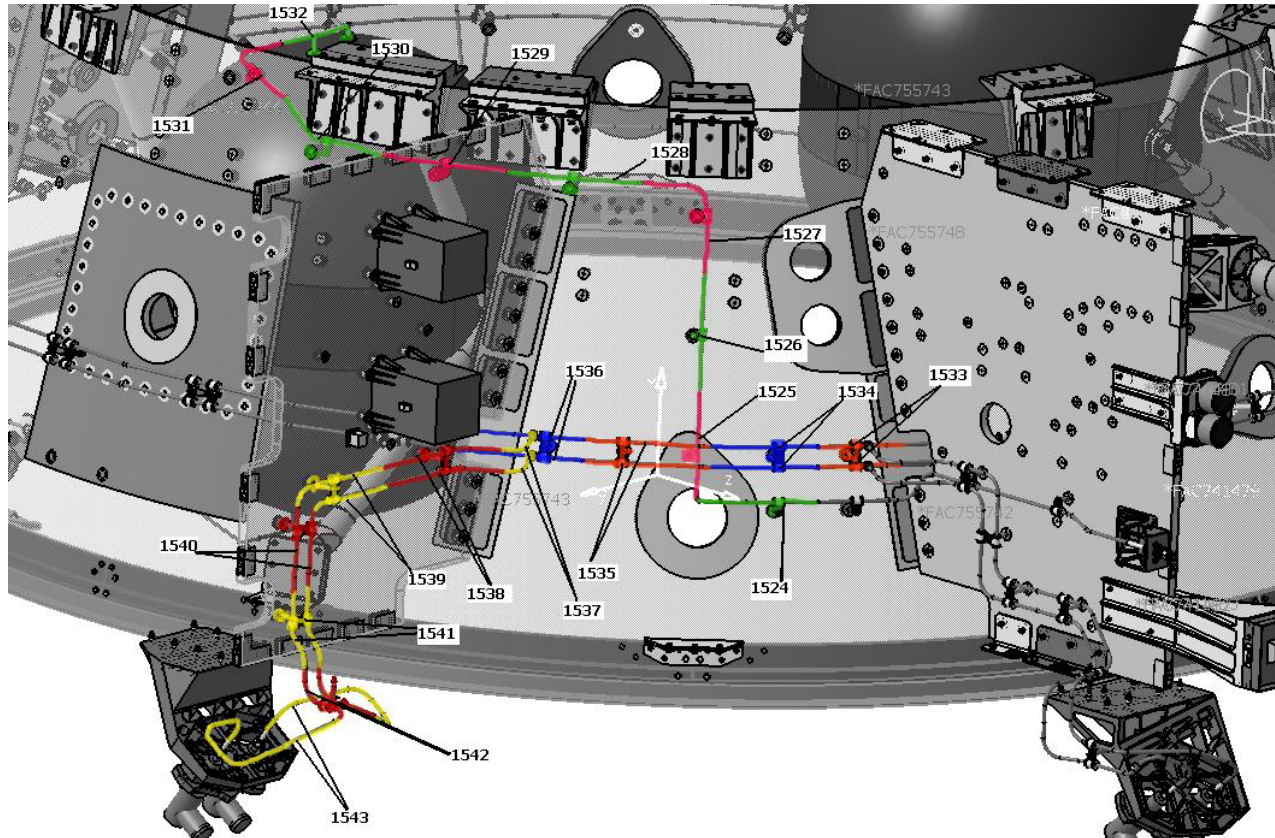

Figure 3.1.4-4 HERSHEL – RCS line11



Controlled Distribution

REFERENCE : H-P-RP-AI-0040

DATE : 29/SEP/06

ISSUE : 06

Page : 44/405

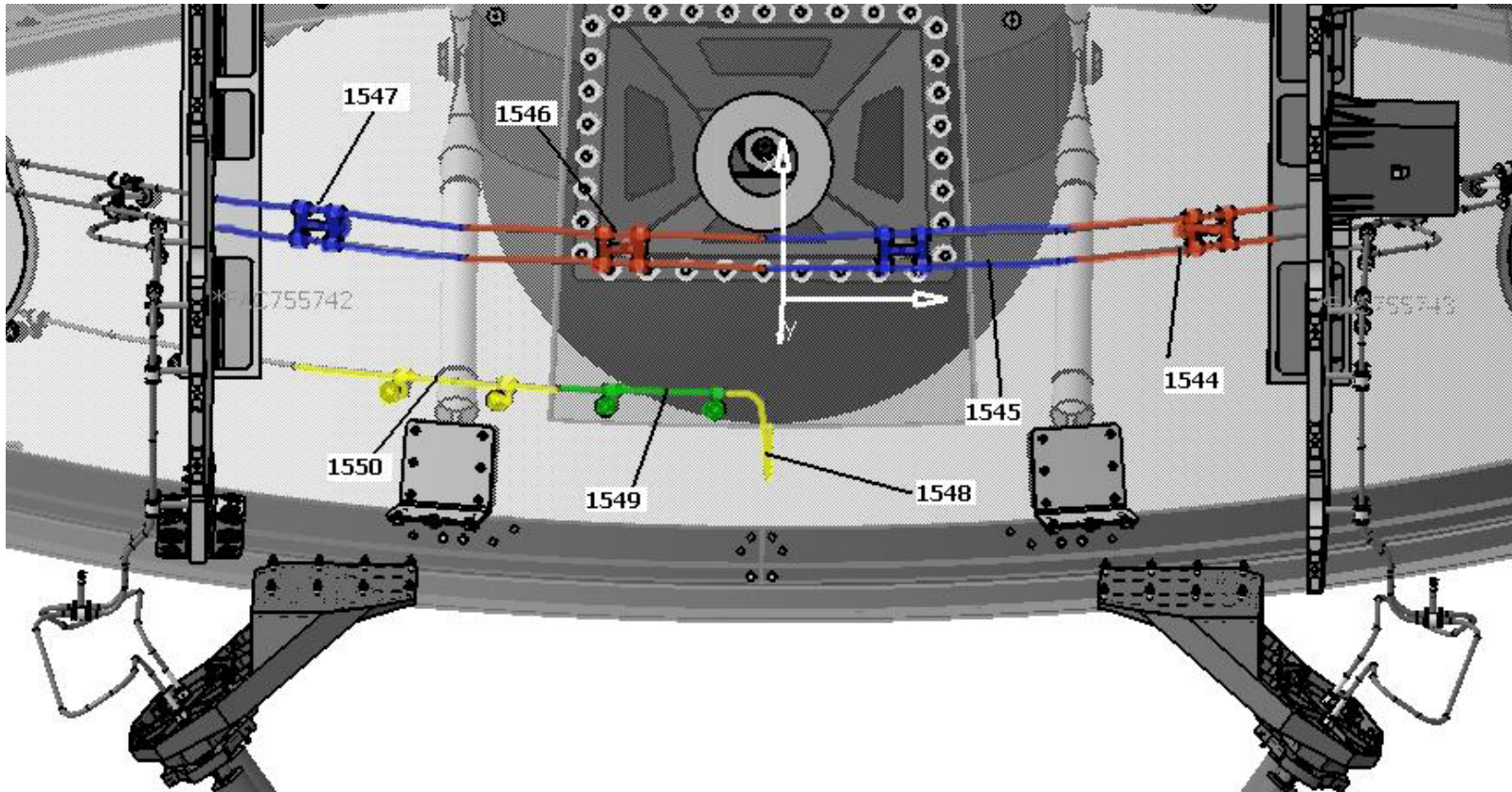

Figure 3.1.4-5 HERSHEL – RCS line11



Controlled Distribution

REFERENCE : H-P-RP-AI-0040

DATE : 29/SEP/06

ISSUE : 06

Page : 45/405

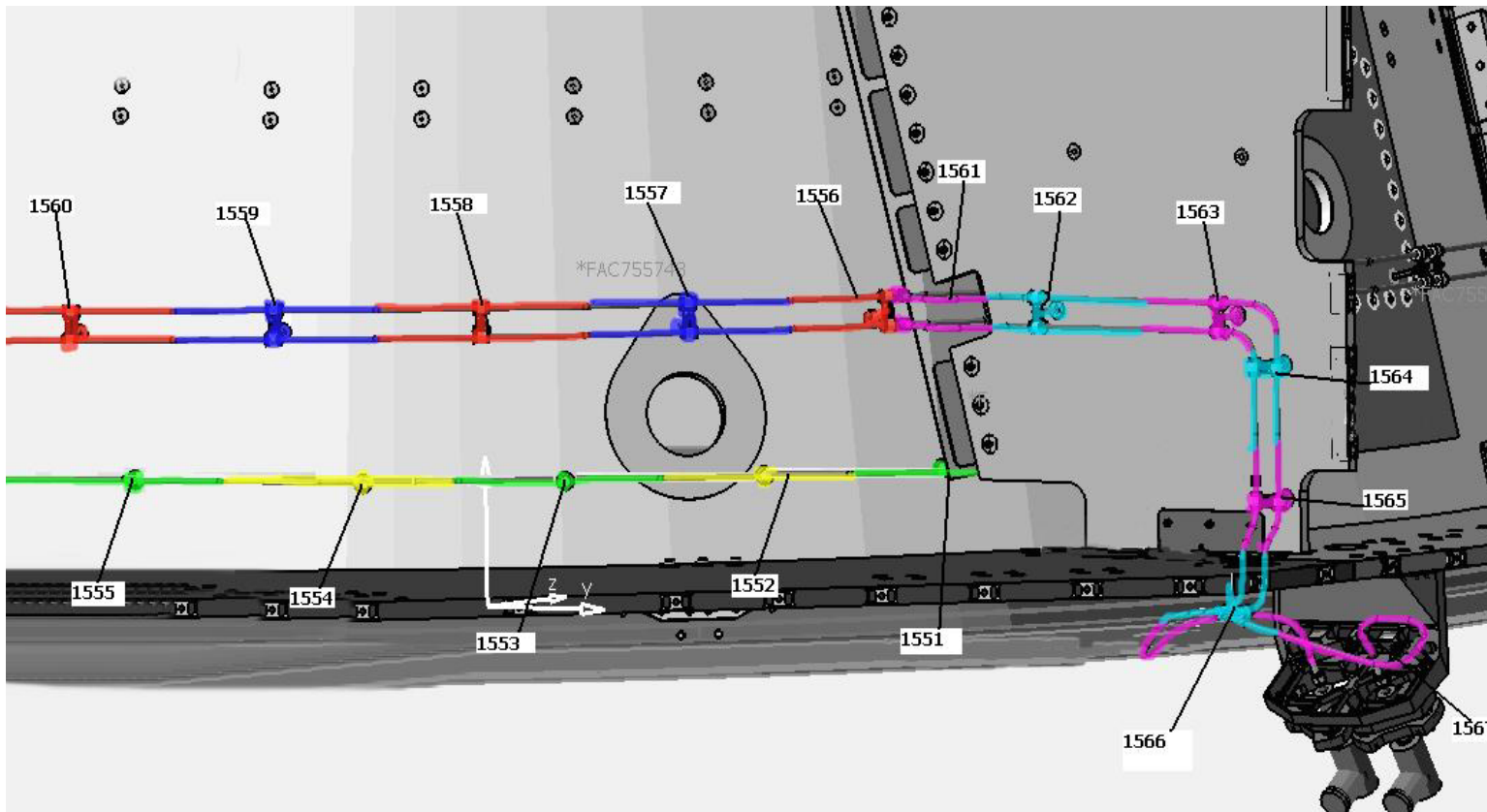

Figure 3.1.4-6 HERSHEL – RCS line35



Controlled Distribution

REFERENCE : H-P-RP-AI-0040

DATE : 29/SEP/06

ISSUE : 06

Page : 46/405

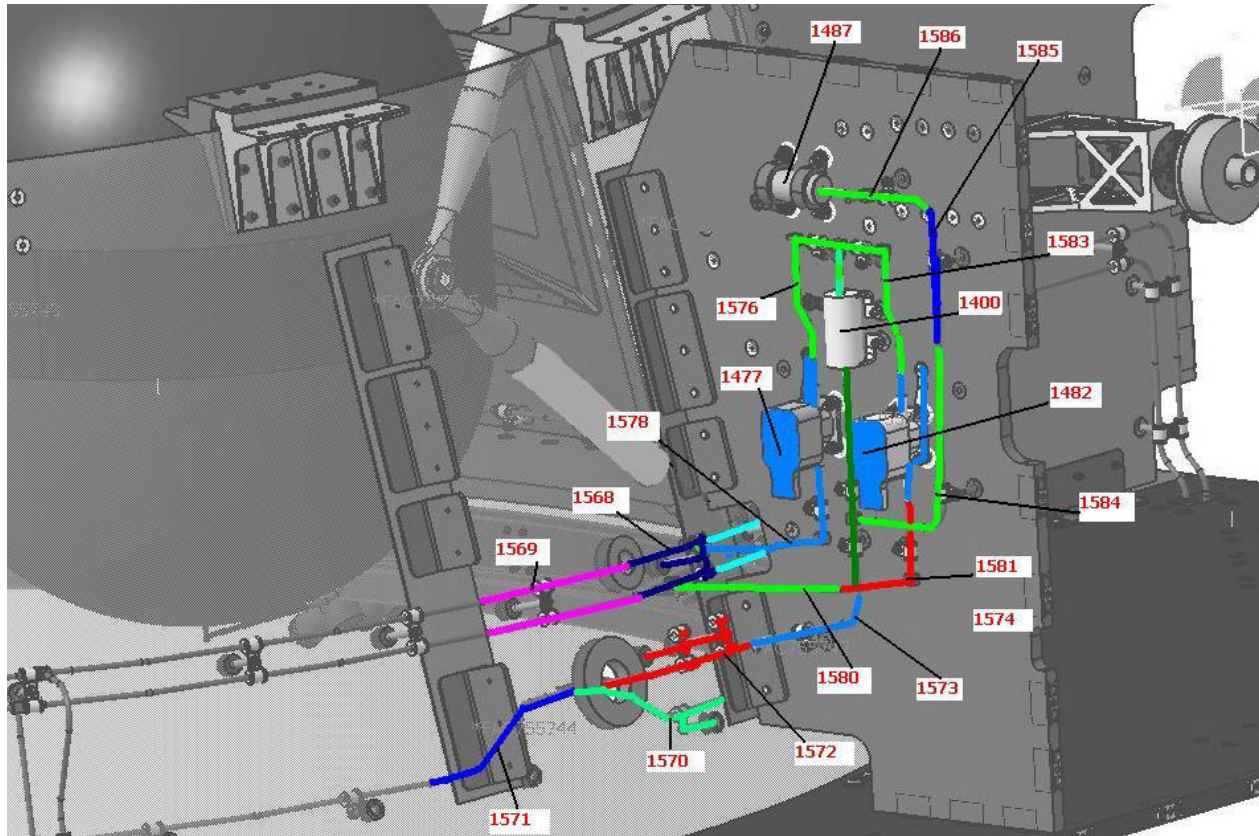

Figure 3.1.4-7 HERSHEL – RCS line37



Controlled Distribution

REFERENCE : H-P-RP-AI-0040

DATE : 29/SEP/06

ISSUE : 06

Page : 47/405

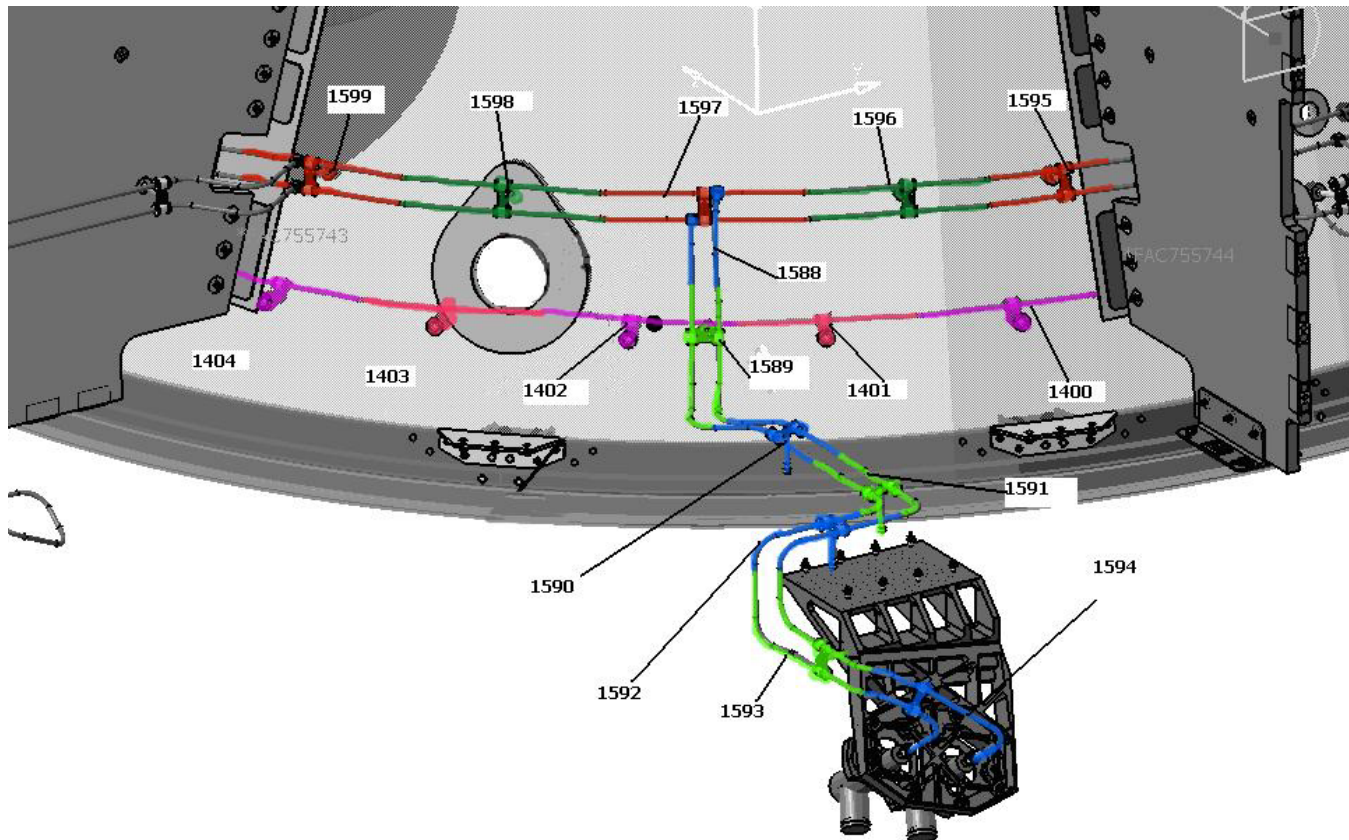

Figure 3.1.4-8 HERSCHEL – RCS line37-45



Controlled Distribution

REFERENCE : H-P-RP-AI-0040

DATE : 29/SEP/06

ISSUE : 06

Page : 48/405

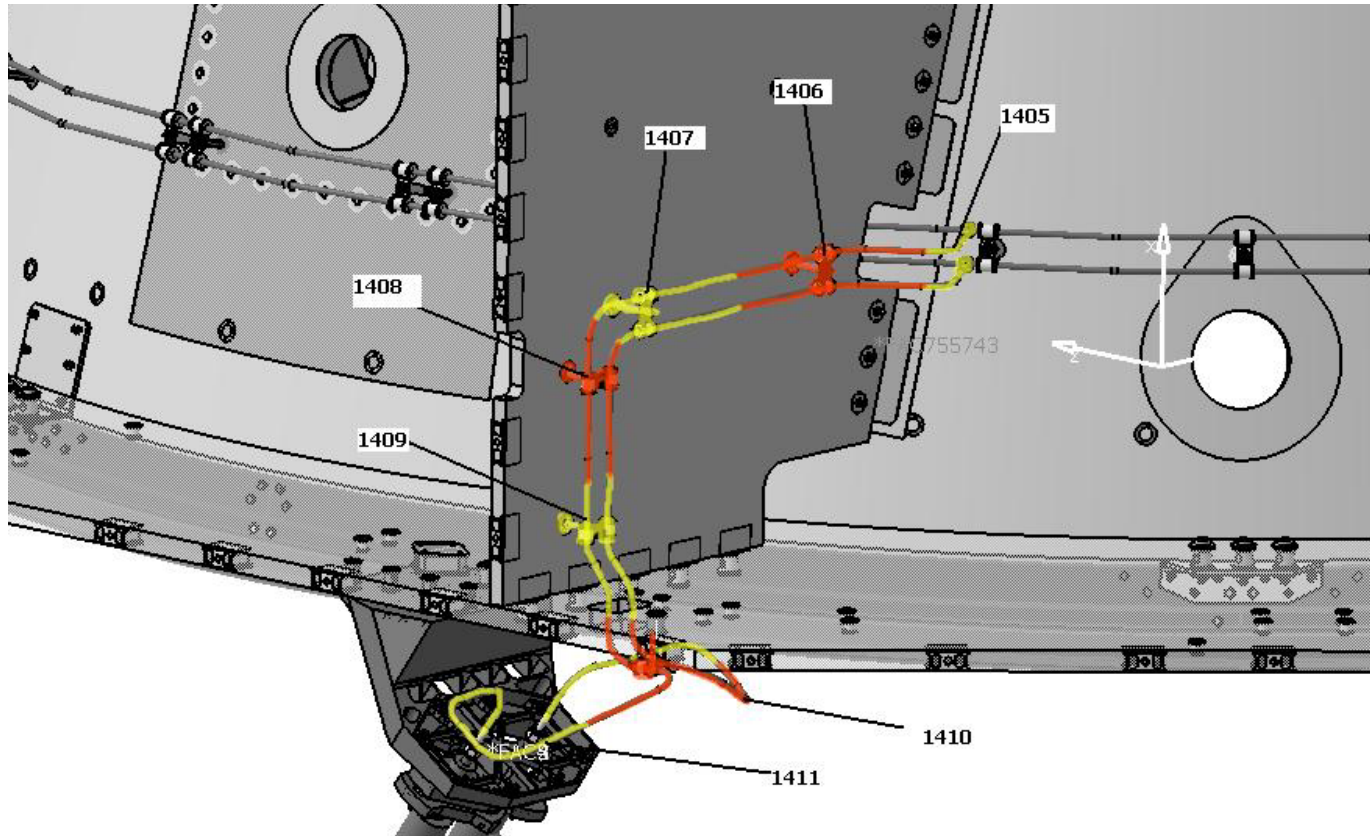

Figure 3.1.4-9 HERSCHEL – RCS line45



Controlled Distribution

REFERENCE : H-P-RP-AI-0040

DATE : 29/SEP/06

ISSUE : 06

Page : 49/405

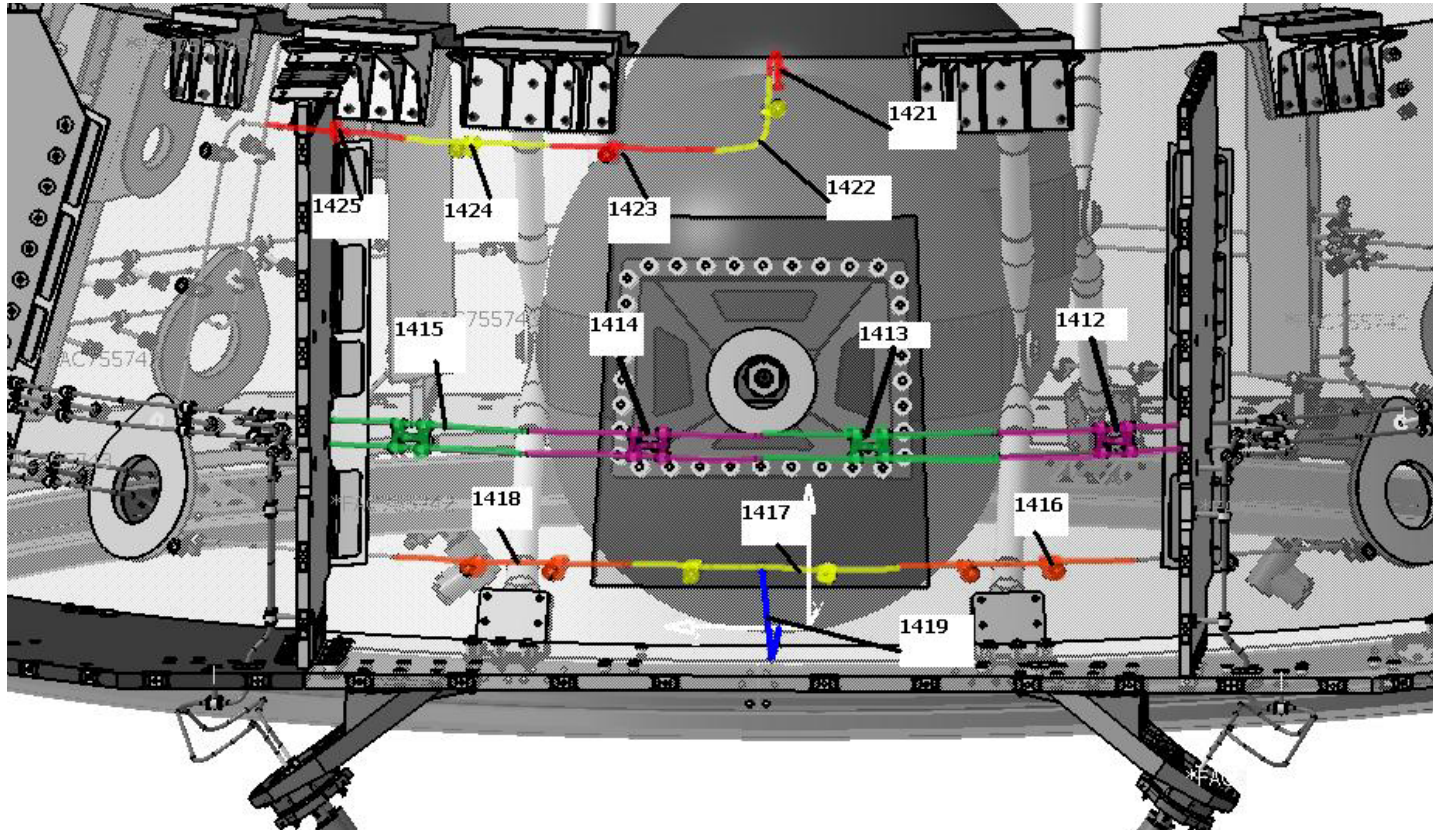

Figure 3.1.4-10 HERSHEL – RCS line46



Controlled Distribution

REFERENCE : H-P-RP-AI-0040

DATE : 29/SEP/06

ISSUE : 06

Page : 50/405

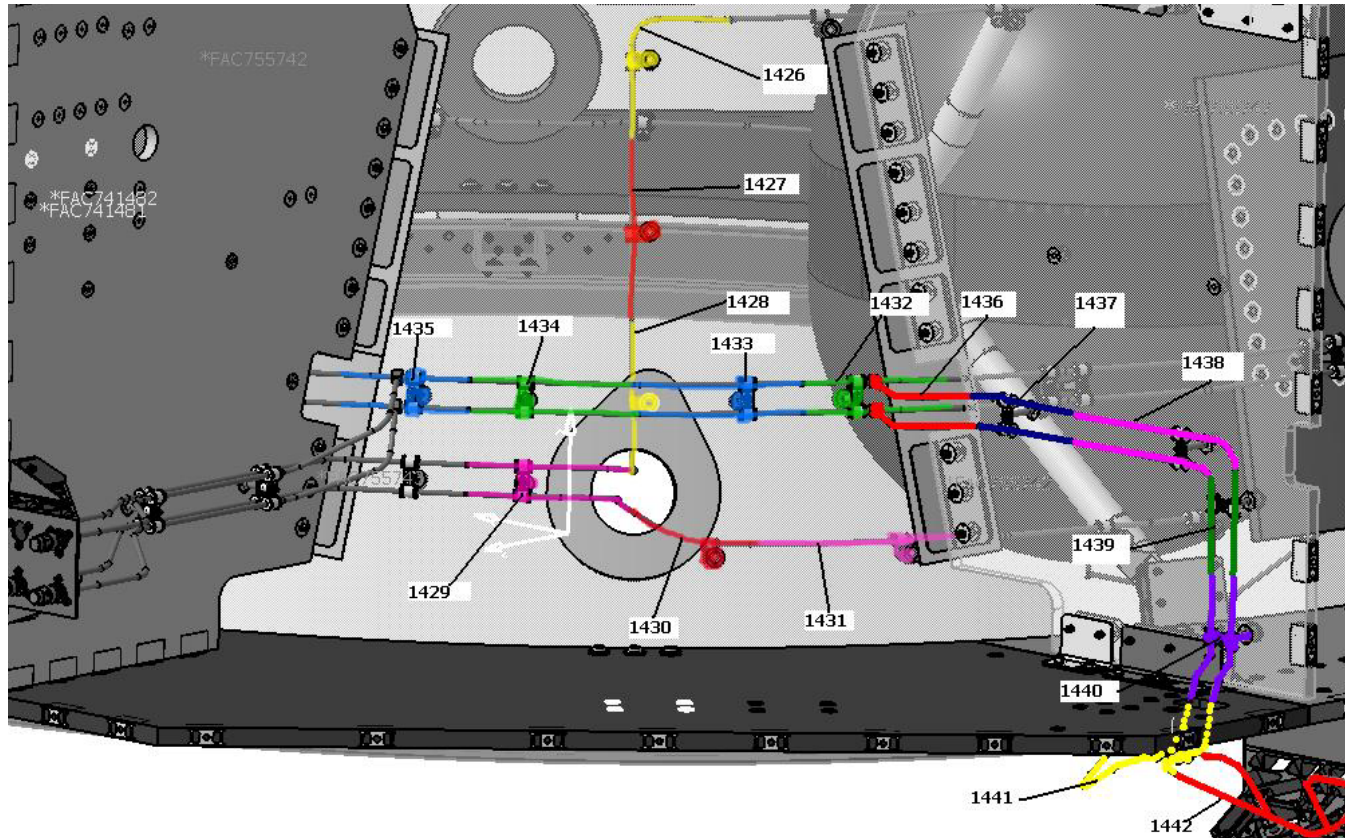

Figure 3.1.4-11 HERSHEL – RCS line47



3.1.5 HERSCHEL Power Dissipations Variations

Herschel Payload Operating Modes are the following, as per [AD9] last issue:

MODE	HIFI	PACS	SPIRE	remarks
1	Prime	Standby	Standby	
2	Standby	Prime	Standby	Photometry / Spectrometry in PACS Prime
3	Standby	Standby	Prime	

Table 3.1.5-1 HERSCHEL – Payload Units operating modes

Power dissipations used in the analysis cases are shown in Table 5.1.2-1. Should be noted that Cold Case analyses (G and H cases) has been performed considering the TT&C units in Nominal mode, the Warm Units in MODE1 and MODE3. Hot Case analyses (A, B, C, D, E and F cases) have been performed considering the TT&C units in Nominal mode, the Warm Units in MODE1 or MODE2 and within the MODE2.

The last updating (from issue 05) is highlighted in blue and it is due to the Change Request H-P-ASP-CR-0885/0866 ([AD34], [AD32]) for the PACS units and HP-TN-AI-0131 [AD35] for the Reaction Wheels:

NODE	LABEL	UNIT POWER DISSIPATION [W]								
		A	B	C	D	E	F	G	H	I
		EOL	EOL	EOL	EOL	EOL	EOL	BOL	BOL	BOL Survival
EXTERNAL										
4	VMC	0	0	0	0	0	0	0	0	0
5	SAS+Z	0	0	0	0	0	0	0	0	0
16	MGA+Z	3-0(*)	3-0(*)	3-0(*)	3-0(*)	3-0(*)	3-0(*)	3-0(*)	3-0(*)	0
21	LGA+Z	0	0	0	0	0	0	0	0	3
41	LGA-Z	0	0	0	0	0	0	0	0	0
45	SAS-Z	0	0	0	0	0	0	0	0	0
49	SREM	2.6	2.6	2.6	2.6	2.6	2.6	2.6	2.6	0
56	AAD	0	0	0	0	0	0	0	0	0
INTERNAL										
70	TANK1	0	0	0	0	0	0	0	0	0
71	TANK2	0	0	0	0	0	0	0	0	0
SHEAR +Z										
100	GYRO	(**)	(**)	(**)	(**)	(**)	(**)	(**)	(**)	(**)
SHEAR +Y										
110	CRS1	7.1	7.1	7.1	7.1	7.1	7.1	7.1	7.1	7.1
111	CRS2	7.1	7.1	7.1	7.1	7.1	7.1	7.1	7.1	7.1
PANEL +Z+Y										
101	RFDN	11.8-0(*)	11.8-0(*)	11.8-0(*)	11.8-0(*)	11.8-0(*)	11.8-0(*)	11.8-0(*)	11.8-0(*)	11.8-0(*)
102	EPC1	9-0(*)	9-0(*)	9-0(*)	9-0(*)	9-0(*)	9-0(*)	9-0(*)	9-0(*)	9-0(*)
103	EPC2	0	0	0	0	0	0	0	0	0
104	XPND1	23-21(*)	23-21(*)	23-21(*)	23-21(*)	23-21(*)	23-21(*)	23-21(*)	23-21(*)	23-21(*)
105	XPND2	10-10(*)	10-10(*)	10-10(*)	10-10(*)	10-10(*)	10-10(*)	10-10(*)	10-10(*)	10-10(*)

Controlled Distribution



REFERENCE : H-P-RP-AI-0040

DATE : 29/SEP/06

ISSUE : 06

Page : 52/405

NODE	LABEL	UNIT POWER DISSIPATION [W]								
		A	B	C	D	E	F	G	H	I
		EOL	EOL	EOL	EOL	EOL	EOL	BOL	BOL	BOL Survival
106	TWTA1	37-0(*)	37-0(*)	37-0(*)	37-0(*)	37-0(*)	37-0(*)	37-0(*)	37-0(*)	37-0(*)
107	TWTA2	0	0	0	0	0	0	0	0	0
PANEL +Y										
201	PCDU (***)	(***)	(***)	(***)	(***)	(***)	(***)	(***)	(***)	(***)
202	CDMU	37.7	37.7	37.7	37.7	37.7	37.7	37.7	37.7	37.7
203	ACC	32.1	32.1	32.1	32.1	32.1	32.1	32.1	32.1	32.1
204	BATT	2.3	2.3	2.3	2.3	2.3	2.3	2.3	2.3	6
PANEL +Y-Z										
PACS										
301	FPSPU1_2	30.3	33.2	33.2	30.3	33.2	33.2	30.3	33.2	0
303	FPDPU	14.7	14.7	14.7	14.7	14.7	14.7	14.7	14.7	0
304	FPBOLC	6.6	37.5	6.6	6.6	37.5	6.6	6.6	6.6	0
305	FPMCEDEC	15.9	19.9	50.3	15.9	19.9	50.3	15.9	15.9	0
PANEL -Z										
401	CCU	5.4	5.4	5.4	5.4	5.4	5.4	5.4	5.4	0
SPIRE										
404	HSDCU	37	37	37	37	37	37	37	37	0
405	HSDPU	15.3	15.3	15.3	15.3	15.3	15.3	15.3	15.3	0
406	HSFCU	42.9	42.9	42.9	42.9	42.9	42.9	42.9	42.9	0
PANEL -Y-Z										
HIFI SHORT										
521	FHWOV	1.5	1.5	1.5	1.5	1.5	1.5	1.5	1.5	0
522	FHHRV	66.3	66.3	66.3	66.3	66.3	66.3	66.3	66.3	0
523	FHICU	31.4	29	29	31.4	29	29	29	31.4	0
524	FHFCU	13	13	13	13	13	13	13	13	0
526	FHWEV	25.7	25.7	25.7	25.7	25.7	25.7	25.7	25.7	0
507	FHIFV	0.3	0	0	0.3	0	0	0	0.3	0
PANEL -Y										
HIFI LONG										
621	FHWOH	1.5	1.5	1.5	1.5	1.5	1.5	1.5	1.5	0
622	FHWEH	25.7	25.7	25.7	25.7	25.7	25.7	25.7	25.7	0
623	FHHRH	66.3	66.3	66.3	66.3	66.3	66.3	66.3	66.3	0
624	FHLCU	43.4	37.6	37.6	43.4	37.6	37.6	37.6	43.4	0
625	FHLSU	40.4	35.8	35.8	40.4	35.8	35.8	35.8	40.4	0
606	FHIFH	0.3	0	0	0.3	0	0	0	0.3	0
PANEL -Y+Z										
701	RWL1	25	25	25	25	25	25	5	5	0
702	RWL2	10	10	10	10	10	10	5	5	0
703	RWL3	15	15	15	15	15	15	5	5	0
704	RWL4	10	10	10	10	10	10	5	5	0
STR ASSEMBLY										



NODE	LABEL	UNIT POWER DISSIPATION [W]								
		A	B	C	D	E	F	G	H	I
		EOL	EOL	EOL	EOL	EOL	EOL	BOL	BOL	BOL Survival
80014-68	STR1	10.95	10.95	10.95	10.95	10.95	10.95	10.95	10.95	0
81014-68	STR2	0	0	0	0	0	0	0	0	0
THRUSTERS										
8102	A1A	0.71	0.71	0.71	0.71	0.71	0.71	0.71	0.71	0.71
8122	A1B	0.71	0.71	0.71	0.71	0.71	0.71	0.71	0.71	0.71
8202	C2A	2.84	2.84	2.84	2.84	2.84	2.84	2.84	2.84	5.68
8222	C2B	2.84	2.84	2.84	2.84	2.84	2.84	2.84	2.84	2.84
8302	C1A	2.84	2.84	2.84	2.84	2.84	2.84	2.84	2.84	5.68
8322	C1B	2.84	2.84	2.84	2.84	2.84	2.84	2.84	2.84	2.84
8402	A2A	0.71	0.71	0.71	0.71	0.71	0.71	0.71	0.71	0.71
8422	A2B	0.71	0.71	0.71	0.71	0.71	0.71	0.71	0.71	0.71
8502	C4A	2.84	2.84	2.84	2.84	2.84	2.84	2.84	2.84	5.68
8522	C4B	2.84	2.84	2.84	2.84	2.84	2.84	2.84	2.84	2.84
8602	C3A	2.84	2.84	2.84	2.84	2.84	2.84	2.84	2.84	5.68
8622	C3B	2.84	2.84	2.84	2.84	2.84	2.84	2.84	2.84	2.84

(*) TT&C power: in Telecom mode (21h) the first value, in Scientific mode (3h) the second one

(**) GYRO power is depending from the temperature level of the baseplate see [AD27]

(***) In Telecom Mode PCDU has a dissipation of 76.2W in BOL and 80.0W in EOL
In Scientific Mode PCDU has a dissipation of 72.8W in BOL and 76.5W in EOL
In Survival Mode PCDU has a dissipation of 63.2W in BOL and 66.5W in EOL

Table 3.1.5-2 HERSCHEL - Units Power Dissipations

3.1.6 HERSCHEL Units Conductors Variations

HERSCHEL Unit-Panel contact conductances (including spreading effect if applicable) are given in Table 3.1.7-1; in this table updated values are highlighted. Further details about calculation methods are given in Par 5.2.

UNIT	NODE	PANEL	CAPACITY [J/K]	CONTACT AREA [cm ²]	CONTACT TYPE	GL [W/K]	
						was	Is
VMC	4	EXTERNAL +Z	360	77	Metal-Metal	1.23	1.70
SAS+Z	5	EXTERNAL +Z	130	7.44	Metal-Metal	0.749 with bracket (AD14)	0.749 with bracket (AD14)
MGA+Z	16	EXTERNAL +Z	69.2		Washer	0.0682 (AD17)	0.0682 (AD17)
LGA+Z	21	EXTERNAL +Z	110		Washer	0.0667 (AD16)	0.0667 (AD16)
LGA-Z	41	EXTERNAL -Z	110		Washer	0.0667 (AD16)	0.0667 (AD16)
SAS-Z	45	EXTERNAL -Z	130	7.44	Metal-Metal	0.749 with bracket	0.749 with bracket

Controlled Distribution



REFERENCE : H-P-RP-AI-0040

DATE : 29/SEP/06

ISSUE : 06

Page : 54/405

UNIT	NODE	PANEL	CAPACITY [J/K]	CONTACT AREA [cm ²]	CONTACT TYPE	GL [W/K]	
						was (AD14)	Is (AD14)
SREM	49	EXTERNAL - Z	2160	295	Metal-Metal	0.7 (integral data)	6.0
AAD	56	EXTERNAL +Z	76.2	5.2	Metal-Metal	0.524 with bracket (AD15)	0.524 with bracket (AD15)
GYRO	81	SHEAR +Z+Y	4800	202	Filler	8.5	2.125
RFDN	101	+ Y + Z	3920	317(*)	Filler	2	2
EPC1	102	+ Y + Z	1287	118.5	Filler	6.33	6.33
EPC2	103	+ Y + Z	1287	118.5	Filler	3.58	3.58
XPND1	104	+ Y + Z	3688	109.2	Filler	5.77	5.77
XPND2	105	+ Y + Z	3688	109.2	Filler	5.77	5.77
TWTA1	106	+ Y + Z	442	136	Filler on Doubler	6.09	6.09
TWTA2	107	+ Y + Z	442	136	Filler on Doubler	6.09	6.09
CRS1	110	SHEAR +Y+Z	1523	29.6(*)	Filler	1.16	1.16
CRS2	111	SHEAR +Y+Z	1523	29.6(*)	Filler	1.16	1.16
PCDU	201	+ Y	23490	1802	Filler	18.0	18.0
CDMU	202	+ Y	12000	551	Filler	8.38	8.38
ACC	203	+ Y	10640	513	Filler	8.25	8.25
BATT	204	+ Y	5520	19.6(*)	Filler	0.57	2.0
FPSPU1-2	301	+ Y - Z	7000	510	Filler	8.92	8.92
FPDPU	303	+ Y - Z	7177	664	Filler	8.92	26.76
FPBOLC	304	+ Y - Z	17500	1105	Filler	10.65	10.65
FPMECDEC	305	+ Y - Z	18400	1736	Filler	16.52	16.52
CCU	401	- Z	6790	720	Filler	8.43	8.43
HSDCU	404	- Z	18369	282	Filler	8.62	8.62
HSDPU	405	- Z	7177	644	Filler	8.9	8.9
HSFCU	406	- Z	17900	500	Filler	9.32	9.32
FHWOV	501	- Y - Z	5100	2.4(*)	Filler	0.213	0.213
FHHRV	502	- Y - Z	10950	1102	Filler on Doubler	10.93	21.86
FHICU	503	- Y - Z	7621	644	Filler	8.3	8.3
FHFCU	504	- Y - Z	7300	763	Filler	9.55	9.55
FHWEV	506	- Y - Z	6600	38.5(*)	Filler on Doubler	6.84	6.84
FHIFV	507	- Y - Z	480	49	Filler	1.5	1.5
FHWOH	601	- Y	5100	2.4(*)	Filler	0.213	0.213
FHWEH	602	- Y	6600	38.5(*)	Filler on Doubler	6.84	6.84
FHHRH	603	- Y	10950	1102	Filler	10.92	21.84
FHLCU	604	- Y	12000	750	Filler	9.34	9.34
FHLSU	605	- Y	11200	970	Filler	9.52	9.52
FHIFH	606.0	- Y	480	49	Filler	1.86	1.20
RW1	701	- Y + Z	4400		Metal-Metal	0.13	1.05



Controlled Distribution



REFERENCE : H-P-RP-AI-0040

DATE : 29/SEP/06

ISSUE : 06

Page : 55/405

UNIT	NODE	PANEL	CAPACITY [J/K]	CONTACT AREA [cm ²]	CONTACT TYPE	GL [W/K]	
						was	Is
RW2	702	- Y + Z	4400		Metal-Metal	0.13	1.11
RW3	703	- Y + Z	4400		Metal-Metal	0.11	1.05
RW4	704	- Y + Z	4400		Metal-Metal	0.11	1.11
THR1	8133	+Z	92.1		Filler	0.8	1.6
THR2	8233	+Y+Z	92.1		Filler	0.8	1.6
THR3	8333	+Y-Z	92.1		Filler	0.8	1.6
THR4	8433	-Z	92.1		Filler	0.8	1.6
THR5	8533	-Y-Z	92.1		Filler	0.8	1.6
THR6	8633	-Y+Z	92.1		Filler	0.8	1.6
STR1					Metal-Metal	1.13 / 1.65 (AD26)	0.3 / 0.5
STR2					Metal-Metal	1.13 / 1.65 (AD26)	0.3 / 0.5

(*) On feet

Table 3.1.6-1 HERSCHEL - Units-Panels conductance



3.1.7 HERSCHEL SVM-Payload I/F points

The interface nodes are the same of the CDR configuration:

I/F NODES	I/F TYPE
2701÷2712	CVV I/F
2713÷2714	I/F SH1-2 SSH BRACKETS
2715÷2717	I/F SSH STRUTS
2718÷2725	I/F SVM SHIELD
2726÷2731	I/F SS1÷6 SVM SHIELD

Table 3.1.7-1 HERSCHEL – SVM-Payload I/F points

In the following figure the attachment points with the PLM are shown.

Controlled Distribution

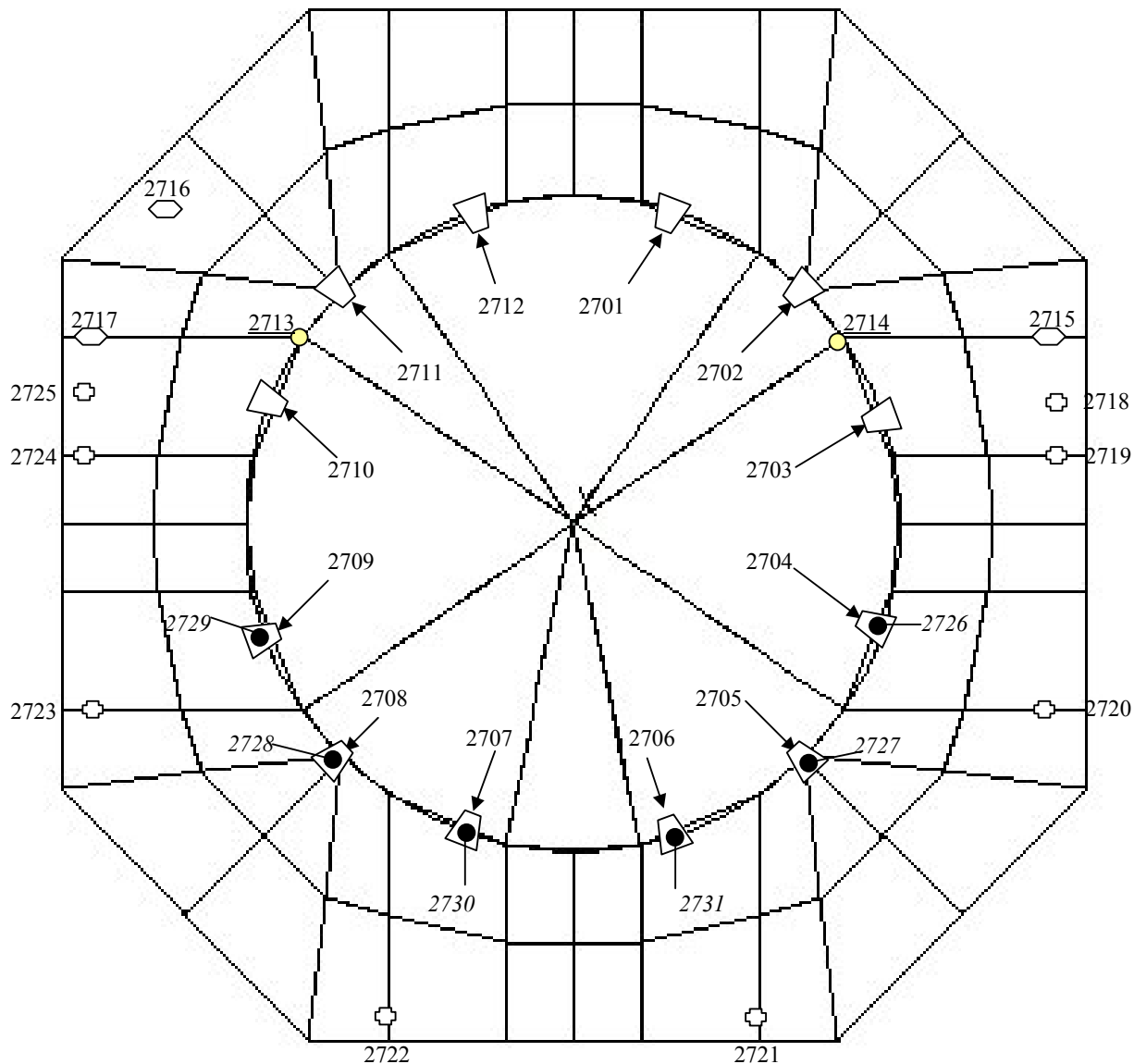

Figure 3.1.7-1 HERSCHEL – I/F points with PLM

4 PLANCK MODELS DESCRIPTION

The Geometric Mathematical Model (GMM) of PLANCK satellite has been built using Esarad (version 5.8) software and it is composed by two models, which describe respectively the internal enclosures of the spacecraft and the external environment of the spacecraft. A reduced model of the Payload Module, furnished by ALCATEL [AD19], has been introduced in the external GMM.

The Thermal Mathematical Model (TMM) of PLANCK has been prepared with Esatan (version 9.6) software and contains the thermal node description, the thermal conductivity network and the unit and heater dissipation.

The overall Thermal model of Planck is composed of 3004 nodes; 2179 are Geometrical Nodes; 1108 nodes are in the External GMM, 1071 nodes are in the Internal GMM (including 6 nodes coming from the Payload Module given by [AD19]).

The termo-optical properties of the material used in the GMM/TMM are listed in Table 4.1.1-3. The nodes of GMM/TMM with Number, Label, Area, Capacity, Material and thermal properties of each node at BOL / EOL conditions are provided in the [AD25].

The only thermal property assumed to change during the satellite life is the solar absorptivity of the Solar array and of the Silver Teflon Tape.

The nodal breakdown of the GMM is reported in [AD25].

An overall view of PLANCK satellite is presented in the following figures.

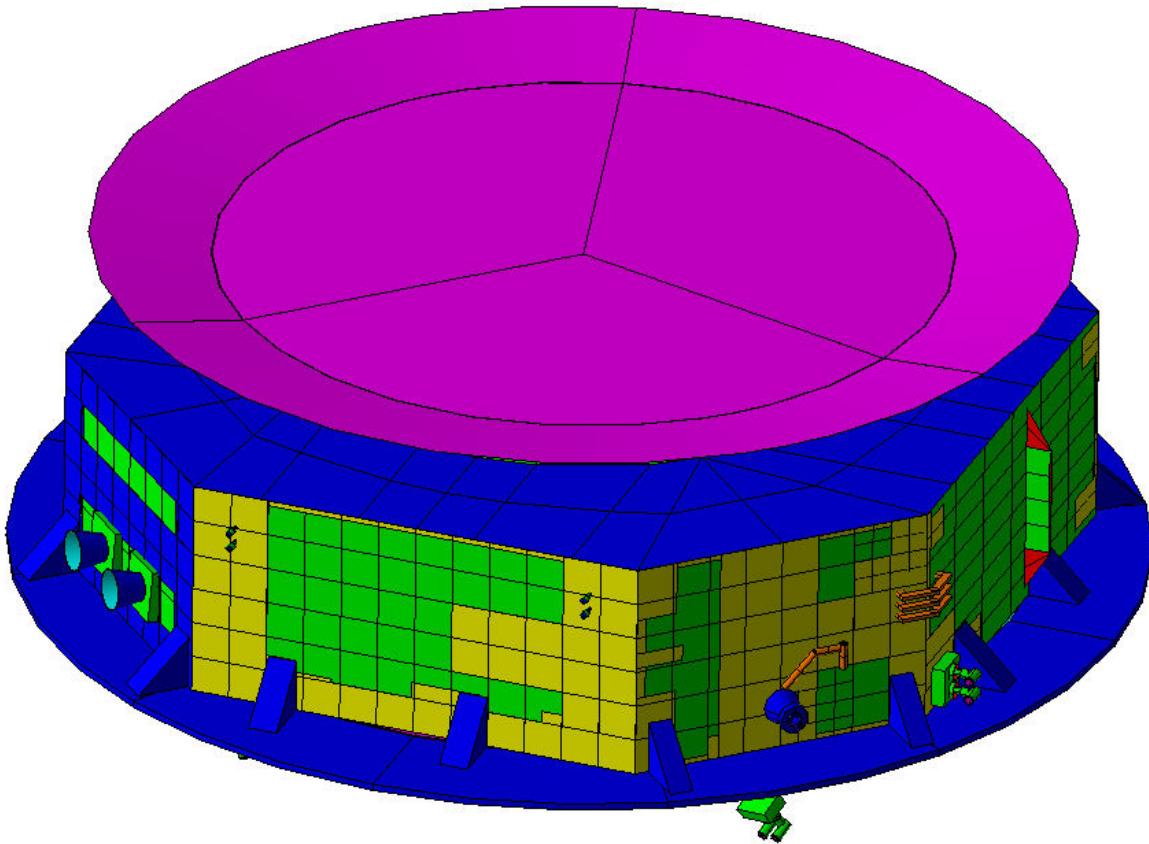

Figure 4-1 PLANCK - Overall view

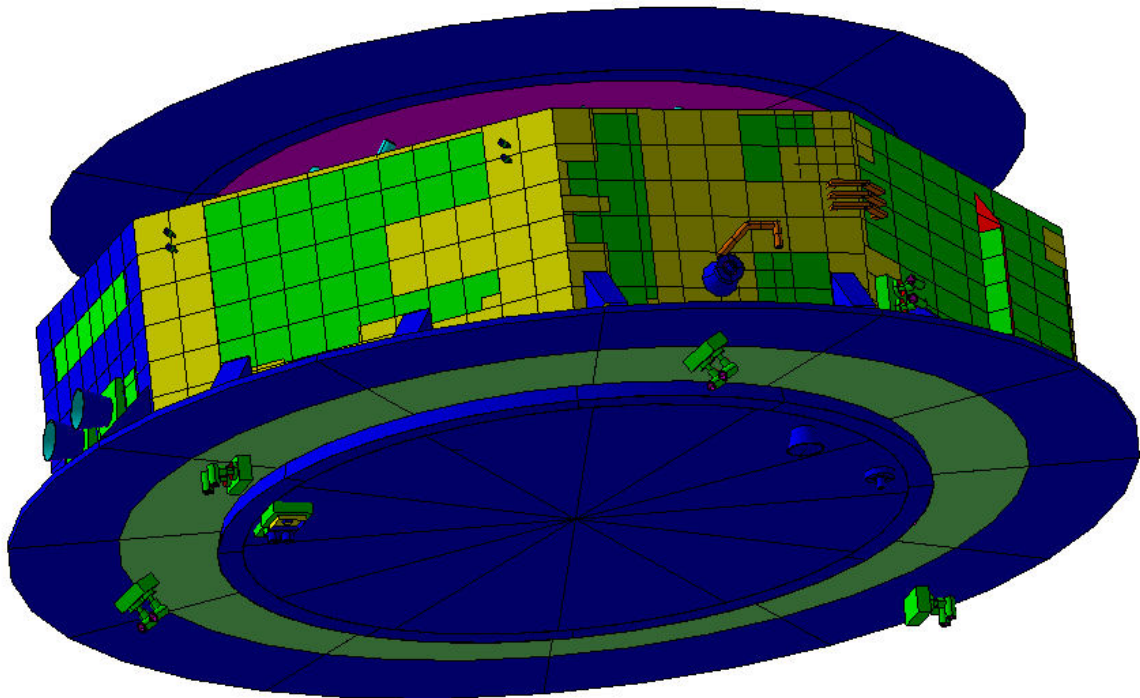

Figure 4-2 PLANCK - Overall view

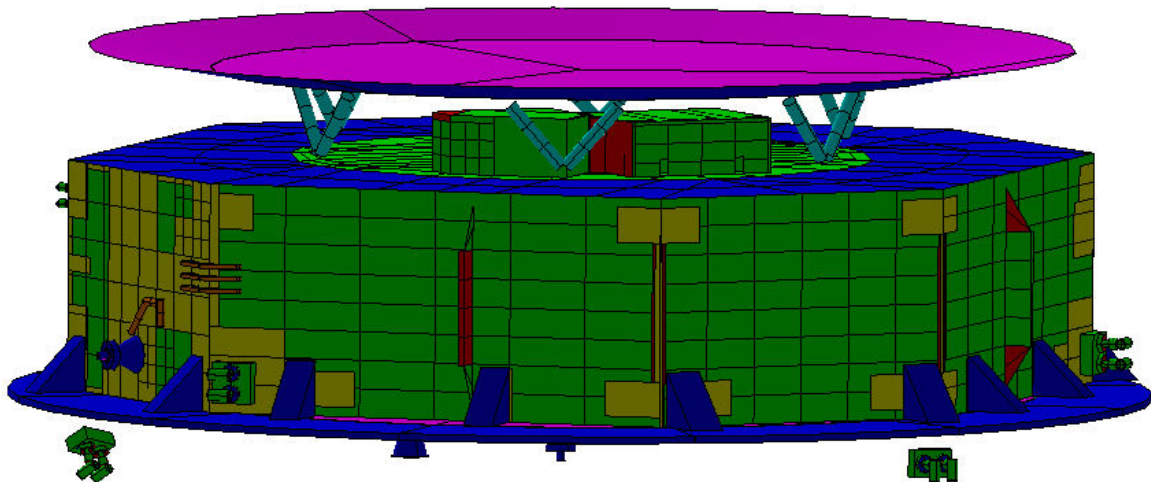

Figure 4-3 PLANCK - Overall view

Controlled Distribution



REFERENCE : H-P-RP-AI-0040

DATE : 29/SEP/06

ISSUE : 06

Page : 61/405

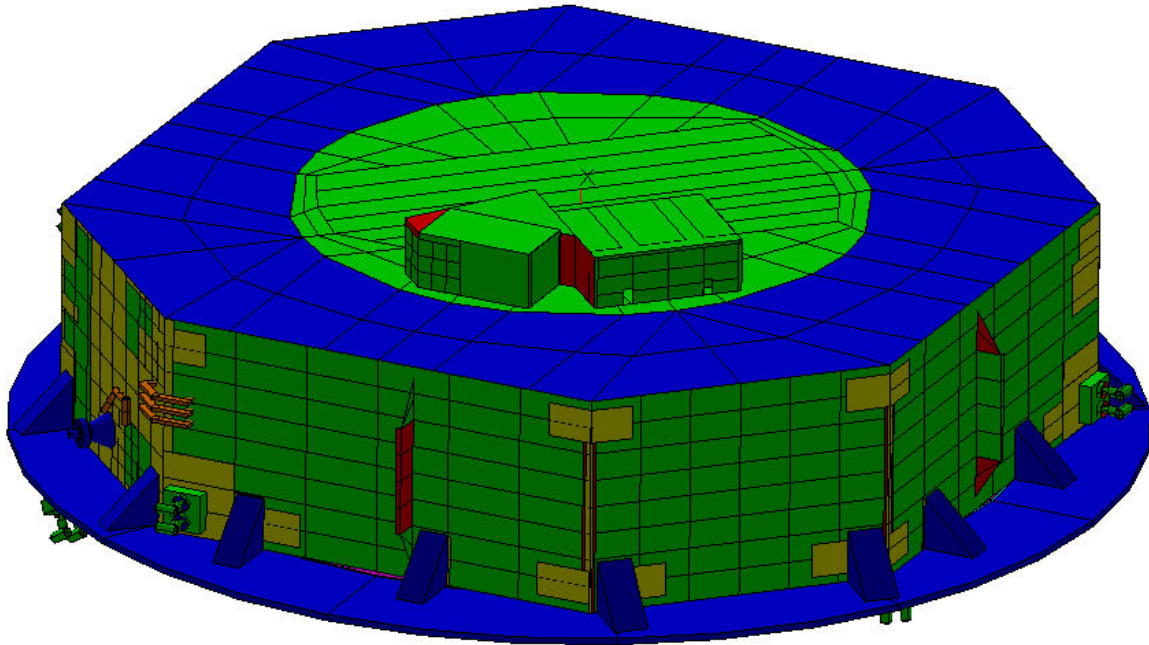

Figure 4-4 PLANCK - Overall view (Groove shield not plotted)



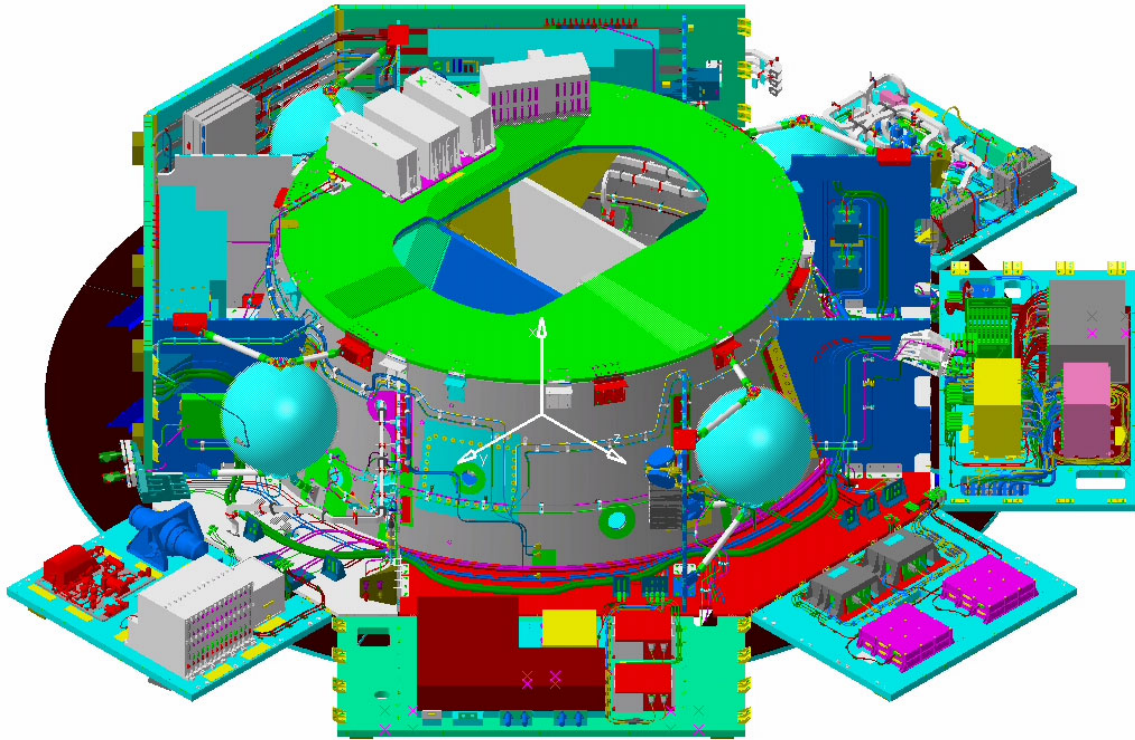

Figure 4-5 PLANCK – Internal overall View

4.1 PLANCK GMM and TMM variations after Correlation Activity (July 2006)

Variations applied to GMM and TMM models due to the TV/TB test campaign and the model correlation activity, already reported in [AD39], are maintained for the Flight Analysis; in the following paragraphs, major modifications coming from the correlation activity will be only summarized, and modifications due to the updated Flight Configuration will be highlighted.

4.1.1 PLANCK External GMM Variations

Major External GMM modifications are related to external MLI, Wave Guides, and the thermal-optical properties; for more details see [AD39].

- External MLI layout modifications
A general refinement of the external panels MLI nodes has been performed after TV/TB test campaign; a list of the affected nodes is in the following table:

PANEL	AFFECTED NODES	ADDED/NEW NODES	GMM CONFIGURATION	
			was	is
-Y	3602, 3610, 3617, 3618, 3625, 3626, 3634, 3642	4602, 4610, 4617, 4618, 4625, 4626, 4633, 4634, 4642	Black Paint	partially covered with Black MLI
	4603, 4611, 4619, 4627, 4635, 4643	3603, 3611, 3619, 3627, 3635, 3643	Black MLI	partially covered with Black MLI
	3606, 3607, 3647, 3647	4606, 4607, 4646, 4647	Black Paint	partially covered with Black MLI
	4623, 4624, 4631, 4632, 4639, 4640	4927, 4928, 4929	WG MLI	WG tubes
+Z	3010, 3012, 3013, 3015, 3034, 3039	4010, 4012, 4013, 4015, 4034, 4039	Black Paint	partially covered with Black MLI
	4018, 4020, 4021, 4023	3018, 3020, 3021, 3023	Black MLI	partially covered with Black MLI
	4902, 4942	4922, 4962	Black MLI	Black MLI
-Y+Z	3716, 3718, 3722	4716, 4718, 4722	Black Paint	partially covered with Black MLI
	4719	3719	Black MLI	partially covered with Black MLI
+Y	3266, 3267, 3270, 3271	4933, 4934, 4931, 4932	Black Paint	partially covered with Black MLI

Table 4.1.1-1 PLANCK – MLI GMM modifications

In the following Figures 4.1.1-2 to 4.1.1-8 new external meshes and related nodal breakdowns are shown, while in Table 4.1.1-2 a summary of current radiator areas is given.

Controlled Distribution

Panel Location	Total GMM Panel Area [m ²]	GMM MLI Area [m ²]	GMM Radiative Area [m ²]	GMM Rad. Area / Total panel %
+Z	0.974	0.795	0.179	18%
+Y +Z	1.462	1.056	0.406	28%
+Y	0.974	0.275	0.699	72%
+Y -Z	1.462	0.269	1.193	82%
-Z	0.974	0.129	0.845	87%
-Y -Z	1.462	0.276	1.186	81%
-Y	0.974	0.664	0.310	32%
-Y +Z	1.462	0.827	0.635	43%
Total Panels	9.744	4.291	5.453	56%
BEU	-	-	0.1026	-
PAU	-	-	0.0608	-

Table 4.1.1-2 PLANCK – GMM Radiative and MLI Areas

- External Radiators layout modifications

For the TT&C (-Y) panel a refined panel mesh in the TWT heads areas has been implemented; in the following Figures 4.1.1-2 to 4.1.1-8 external panels layouts are numbered in red for MLI blankets and in blue for radiator areas.
- Solar Arrays modifications

A refined mesh has been implemented: the external solar array is now divided in a outer zone, exposed to space on both sides (+X and -X), and an inner zone, facing the SVM on +X side and exposed to space on -X side. The external side of the central solar array has a new mesh, too. See Figures 4.1.1-7 and 4.1.1-8 for details.
- Thermal-optical Properties

As per Herschel, the thermal-optical properties of external surfaces in the GMM have been modified after a measurement campaign, according to [AD29] and [AD30].
Modified values since the previous issue of the document are highlighted in Table 4.1.1-3

Controlled Distribution

SURFACES	MATERIALS	α BOL	α EOL	ε	Reference
GMM INTERNAL					
Internal panels, floors, cone, web	Black Paint Z306			0.87	ALS
MLI on Cone / Shear 5 and 8 of SCC enclosure , S/A disc int.side, Propellant Tank				0.05	ALS
Top and bottom floor of SCC enclosure				0.1	ALS assumption
He Tank -Y	Kevlar			0.86	
He Tank +Z,-Y,-Z	Aluminized tape			0.05	
SCC panels (HP and Aluminium skin)				0.18	ALS assumption
4K PREREG, 4K CCU, BEU, PAU, CDMU, ACC	Black paint			0.9	
EPC				0.88	
DPU, DCCU, REBA, FOG, 4K CAU, CEU, REU, DAE POWER, CRS, TWTA, BATTERY, PCDU, SCE	Black Paint Z306			0.87	ALS
XPND,RFDN				0.85	
Doubler under 4KCCU – 4KCAU				0.9	
BEU / PAU enclosure MLI (int.side)	MLI Aluminised			0.04	
1N Thruster				0.4	
GMM EXTERNAL					
AAD top surface		0.96	=	0.83	HP-4-TNO-RP-A004
AAD chip		0.9	=	0.013	HP-4-TNO-RP-A004
External panels	Black Paint Z307	0.96	=	0.88	ALS
MLI to PPLM/ MLI BEU and PAU	VDA Kapton (Al side)	0.15	=	0.04	
MLI	Carbon Filled Kapton	0.92	=	0.87	
BEU/PAU radiators	Black Paint	0.9	=	0.9	
Thrusters nozzle		0.5	=	0.35	Integral data
Thrusters heat barrier / head plate		0.5	=	0.3	Integral data
Thrusters FCV				0.7	Integral data
Launcher adaptor ring	Alodine	0.56	=	0.16	
Launcher adaptor edge	Silver teflon / alodine	0.187	0.316	0.638	Average α / ε values
SAS housing/pyramid		0.96	=	0.83	HP-4-TNO-RP-S004
SAS chip		0.9	=	0.82	HP-4-TNO-RP-S004
SAS –X housing external edge	Carbon Filled Kapton	0.92	=	0.87	
SREM		0.52	=	0.12	Integral data
Solar Array ext disc		0.8	=	0.84	
Solar Array central disc ^(*)		0.86	0.83	0.84	
PLM Groove shield		0.15	=	0.05	HP-1-ASP-TN-0417
PLM struts		0.85	=	0.85	HP-1-ASP-TN-0417
MGA / LGA	Alodine 1200 S	0.46	=	0.1	HP-AN-RY-0020/21
LGA	White paint	0.6	=	0.88	HP-AN-RY-0020
MGA	Germanium	0.6	=	0.72	HP-AN-RY-0021

(*) Average values between Loaded and Unloaded cells; for details see Figure 4.1.1-1

Table 4.1.1-3 PLANCK – SVM Thermal-optical Properties

Controlled Distribution

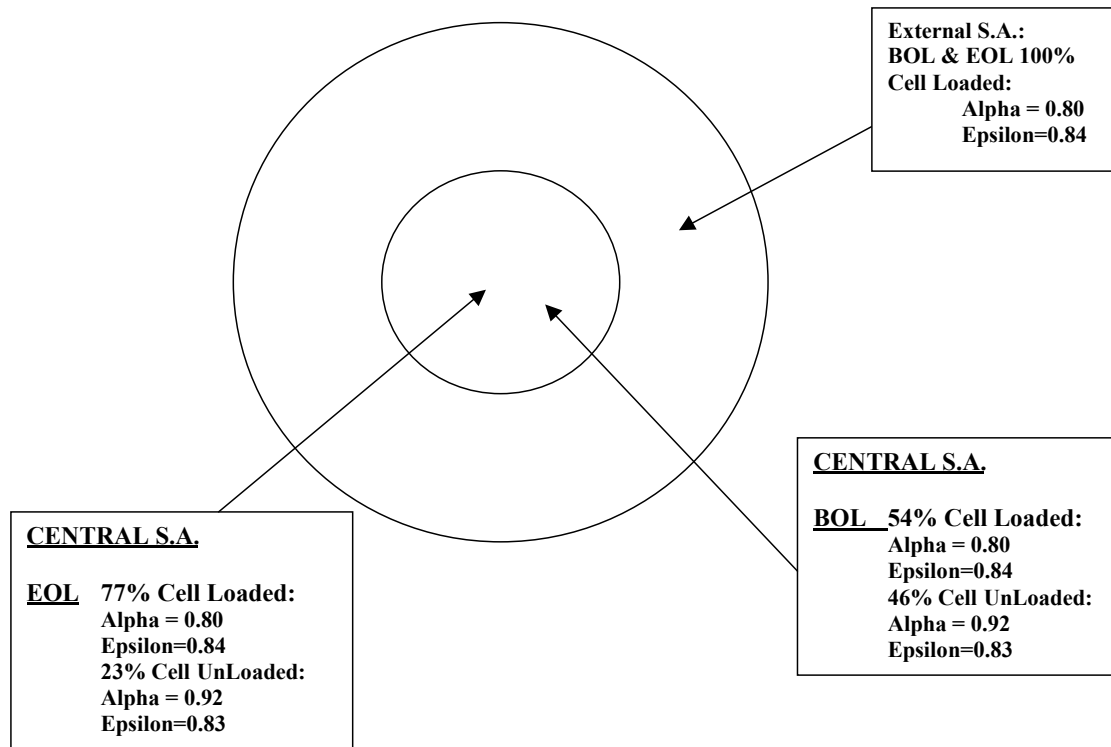

Figure 4.1.1-1 PLANCK – Solar Array thermal-optical properties



Controlled Distribution

REFERENCE : H-P-RP-AI-0040

DATE : 29/SEP/06

ISSUE : 06

Page : 68/405



4641	4642	4643	93	4644	4645	4646	4647		4648
	3642	3643					3661	3662	
4633	4634	3635	85	4636	4637	3638	4639		4640
	3633						3634	3657	
4625	3625	3627	77	4628	4628	4629	4630		4631
4625	4626						3626	4630	
4617	3617	3619	69	4620	4621	4622	4623		4624
4617	4618						3618	4623	
4609	4610	3611	61	4612	4613	3679	3680	3615	4616
						3675	3676		
4601	4602	3603	53	4604	4605	3671	3672	3607	4608
		4603				3667	3668		
	4602					4606	4607		

Figure 4.1.1-2 PLANCK TT&C -Y external panel



Controlled Distribution

REFERENCE : H-P-RP-AI-0040

DATE : 29/SEP/06

ISSUE : 06

Page : 69/405

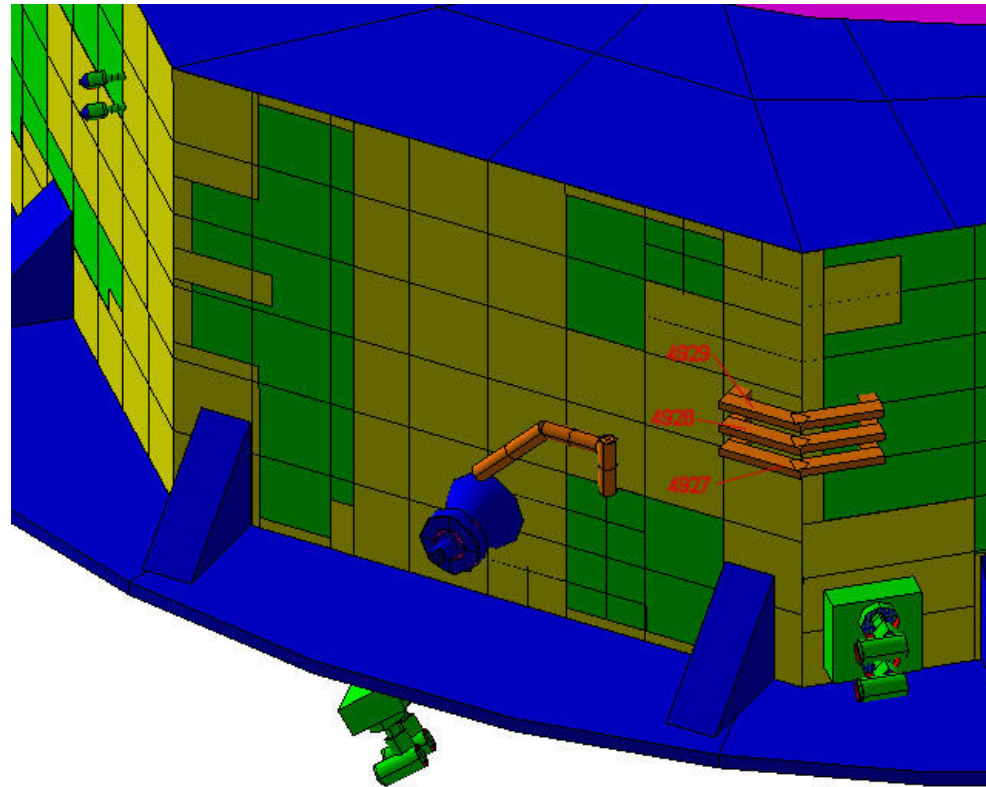

Figure 4.1.1-3 PLANCK TT&C -Y external panel: WG GMM



Controlled Distribution

REFERENCE : H-P-RP-AI-0040

DATE : 29/SEP/06

ISSUE : 06

Page : 70/405

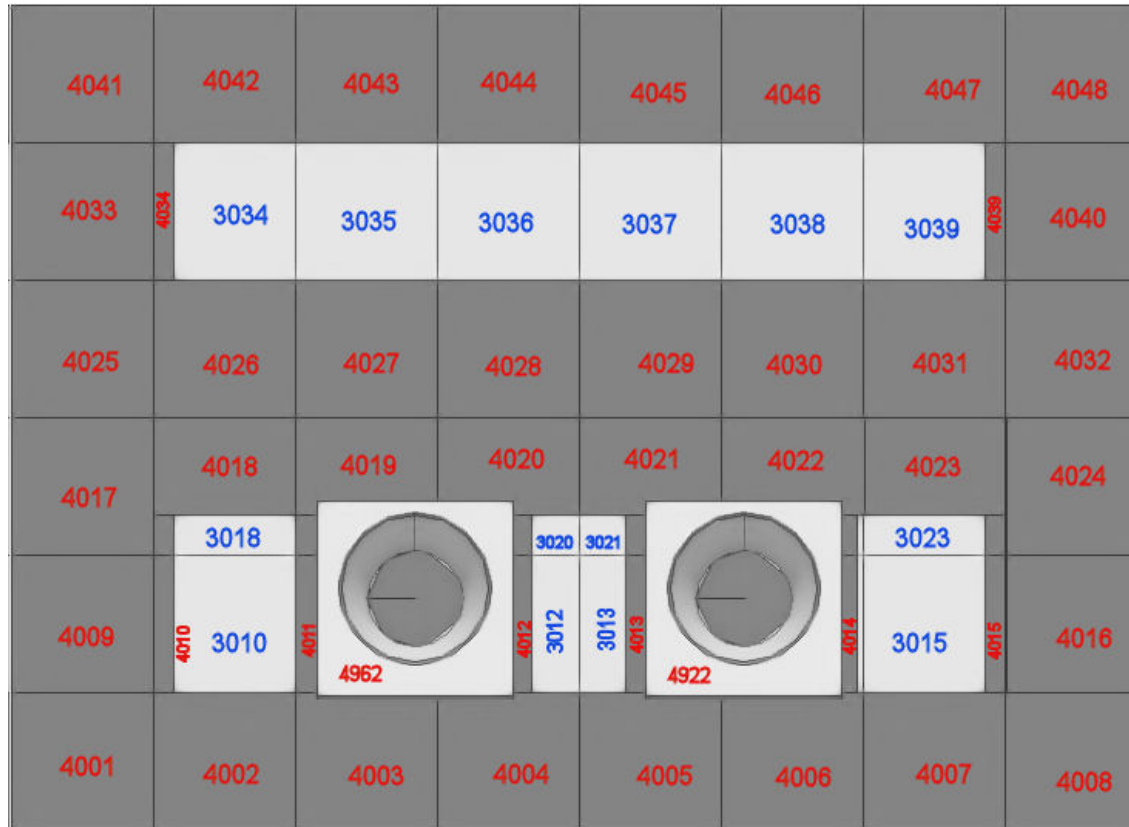

Figure 4.1.1-4 PLANCK DPU +Z external panel



Controlled Distribution



REFERENCE : H-P-RP-AI-0040

DATE : 29/SEP/06

ISSUE : 06

Page : 71/405

		4773									
4761	◆ 4762	3763	3764	3765	3766	6767	3768	3769	3770	4771 ◆	4772
4749	◆ 4750	3751	3752	3753	3754	3755	3756	3757	3758	◆ 4759	4760
4737	4738	3739	3740	3741	3742	3743	4744	4745	4746	4747	4748
4725	4726	3727	3728	3729	3730	3731	4732	4733	4734	4735	4736
4713	4714	3715	3716	3717	3718	3719	3720	3721	3722	4723	4724
		4715	4716		4718	4719	4720		4722		
4701	4702	4703	4704	4705	4706	4707	4708	4709	4710	4711	4712

Figure 4.1.1-5 PLANCK PWR -Y+Z external panel



Controlled Distribution

REFERENCE : H-P-RP-AI-0040

DATE : 29/SEP/06

ISSUE : 06

Page : 72/405

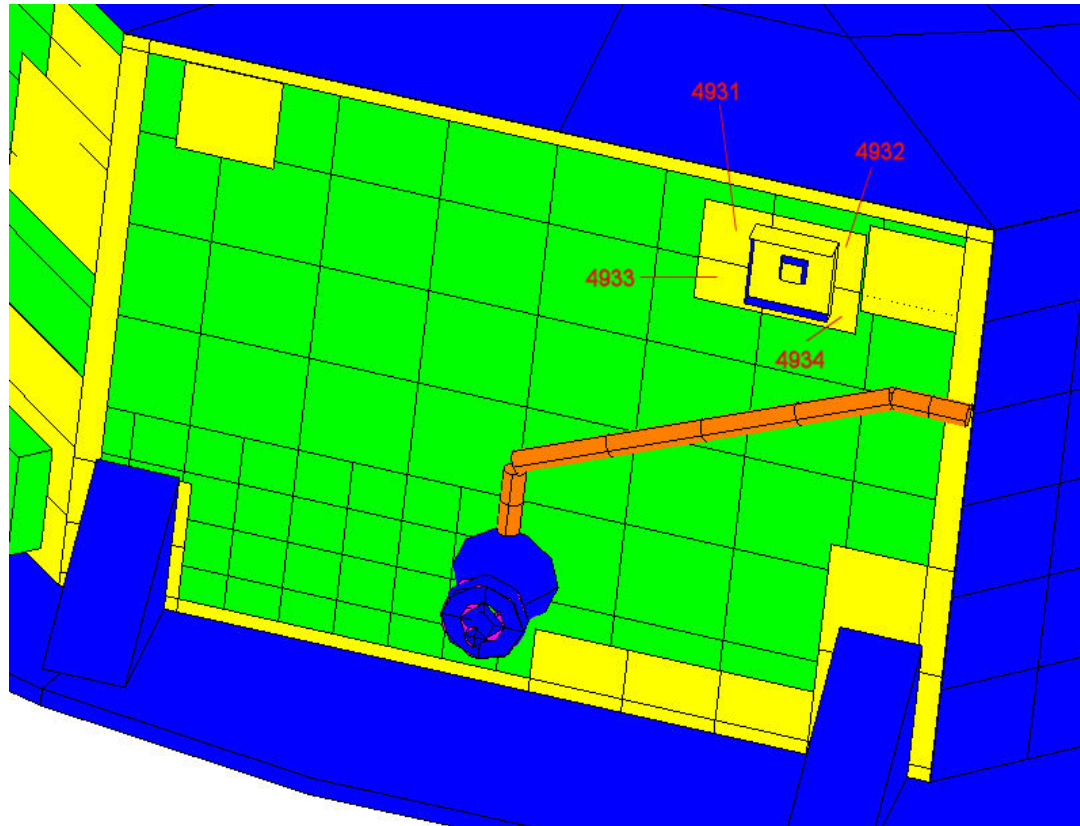

Figure 4.1.1-6 PLANCK +Y external panel new GMM nodes



Controlled Distribution

REFERENCE : H-P-RP-AI-0040

DATE : 29/SEP/06

ISSUE : 06

Page : 73/405

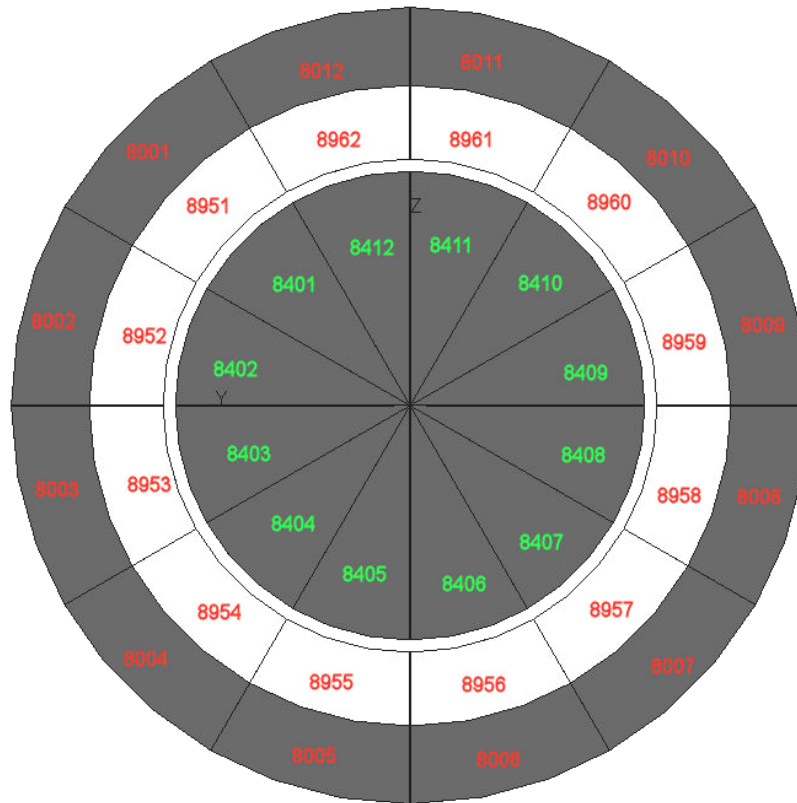

Figure 4.1.1-7 PLANCK Solar Arrays, +X side



Controlled Distribution

REFERENCE : H-P-RP-AI-0040

DATE : 29/SEP/06

ISSUE : 06

Page : 74/405

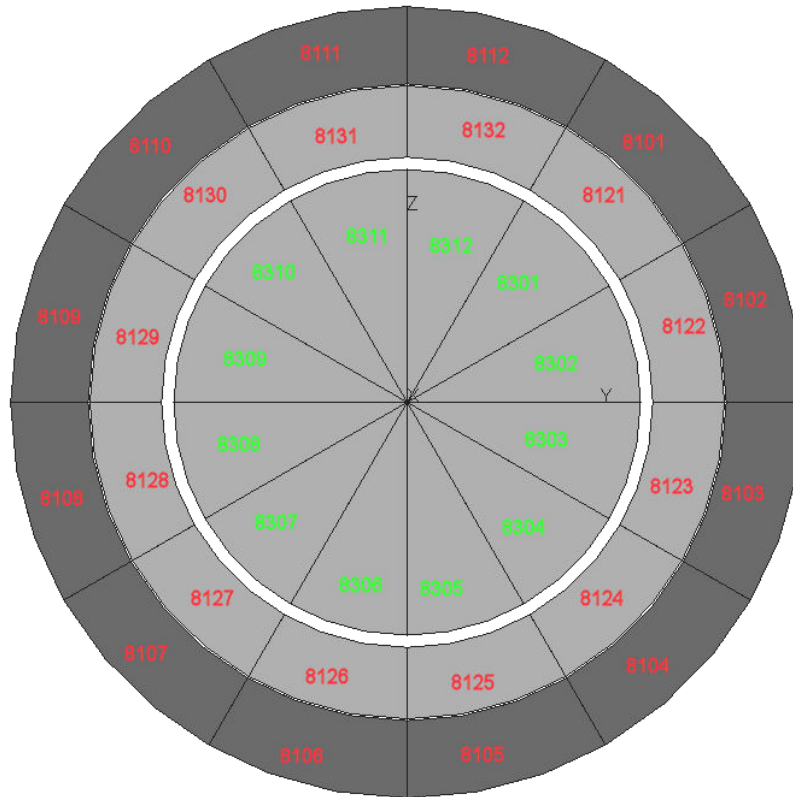

Figure 4.1.1-8 PLANCK Solar Arrays, -X side



4.1.2 PLANCK Internal GMM Variations

Major Internal GMM modifications are related to TT&C Panel, Star Trackers and Helium Tanks:

- TT&C Panels modifications
GMM has been modified introducing an increased detail near TWT Head areas; Table 4.1.2-1 provides the new node numbering, while in Figure 4.1.2-1 details of the new mesh are shown.

TT&C Panel Nodes	
was	is
6603	3, 6603
6611	11, 6611
6619	19, 6619
6627	27, 6627
6635	35, 6635
6643	43, 6643

Table 4.1.2-1 PLANCK – TT&C Panel internal GMM modifications

- Star Trackers MLI modifications
In the previous configuration, for each Star Tracker, the same MLI node covered the STR box both in the external and in the internal GMM; now the external blanket and the internal one have been separated, thus leading in a change of the node numbering. A sketch of the modifications is given in Figure 4.1.2-3.
- Solar Arrays
A refined mesh has been implemented for the internal side (+X) of the central solar array; the new mesh is visible in Figure 4.1.1-6
- He Tank -Y
Due to the correlation activity, only this tank is now modelised by four nodes; see Figure 4.1.2-2 for details.

Controlled Distribution

REFERENCE : H-P-RP-AI-0040

DATE : 29/SEP/06

ISSUE : 06

Page : 76/405

X

6604	6603	6602	6601								
6600	6609	6608	6607	6646	6645	6644	43	6643	6642	6641	
6606	6605	6604	6603								
6602	6601	6600	6649	6638	6637	6636	35	6635	6634	6633	
6632		6631		6630	6629	6628	27	6627	6626	6625	
6624		6623		6622	6621	6620	19	6619	6618	6617	
6616		6615		6600	6679	6678	6677				
				6676	6675	6674	6673	6612	11	6611	6610
6608		6607		6672	6671	6670	6669				
				6668	6667	6666	6665	6604	3	6603	6602

Z

Figure 4.1.2-1 PLANCK TT&C -Y internal panel



Controlled Distribution

REFERENCE : H-P-RP-AI-0040

DATE : 29/SEP/06

ISSUE : 06

Page : 77/405

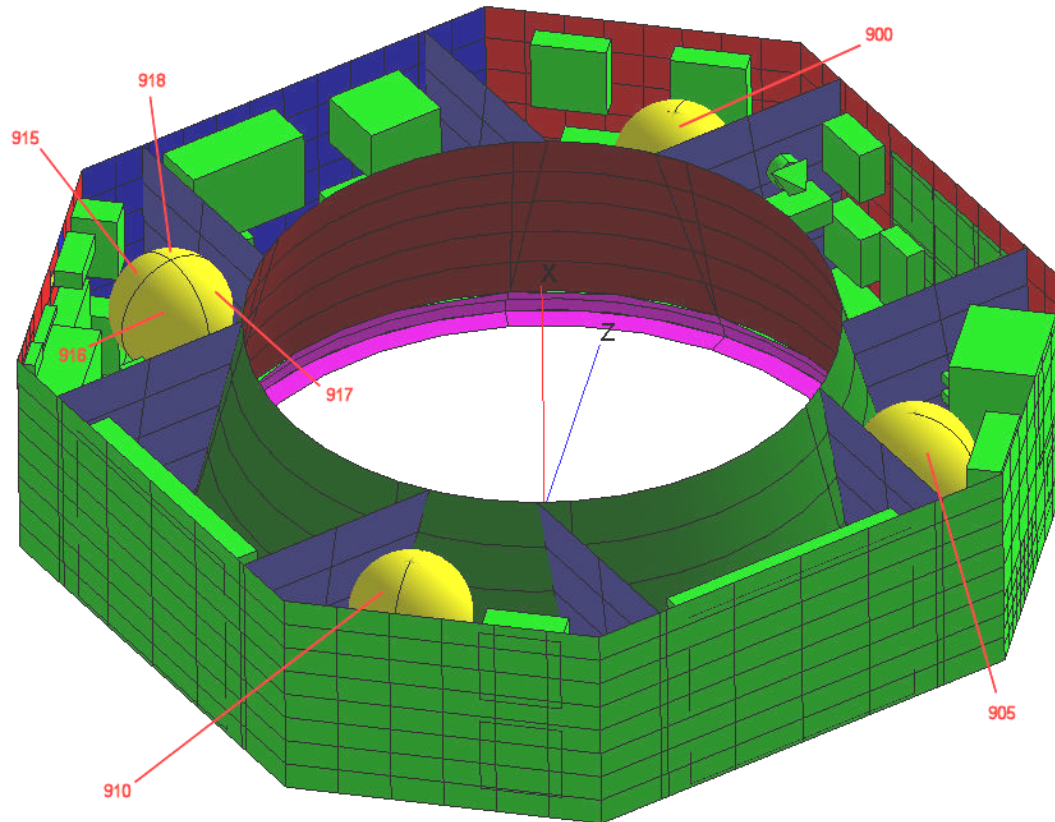

Figure 4.1.2-2 PLANCK He Tanks



Controlled Distribution

REFERENCE : H-P-RP-AI-0040

DATE : 29/SEP/06

ISSUE : 06

Page : 78/405

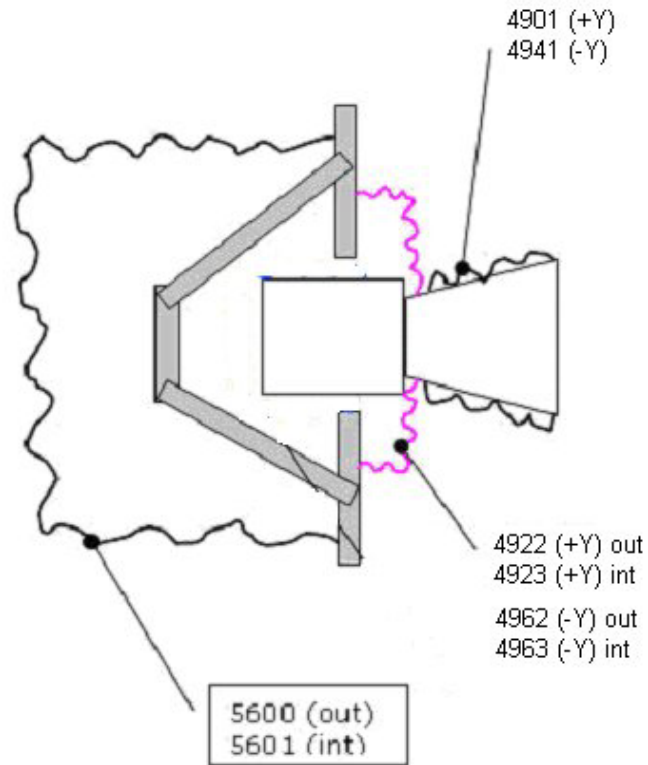

Figure 4.1.2-3 PLANCK Star Trackers MLI



4.1.3 PLANCK TMM Variations

Major TMM modifications described in [AD39] are hereafter only summarised, while modifications due to the updated Flight configurations are highlighted:

- 4K +Y Panel
Doubler conductivity under 4K CCU and 4K CAU has been changed from 150 W/m²/°C to 230 W/m²/°C
- Star Trackers
The main updates implemented in the model include some errors corrections on geometrical model related to the MLI blankets (both on external and internal side), and variation on the linear coupling between the STR bracket and panel (GL doubled).
- Heaters
Variation of heater distribution power for the following lines:
 - Helium Tanks:
Power values have been updated

He Tank	TMM node	TCS Power [W]	
		was	is
-Z	910	0.77	2.08
+Y	905	0.77	1.04
+Z	900	1.54	1.04

Table 4.1.3-2 PLANCK – TCS He Tanks Lines power

- Propellant Tanks:
Installed power (6.17 W for each propellant tank) has not been changed, but a constant quota of this power (0.77 W for each propellant tank) is constantly applied to the tank, while the remaining part (5.4 W for each propellant tank) is thermistor-controlled

Prop. Tank	TMM node	TCS Power [W]	
		was	is
+Z +Y	920	6.17	0.77 + 5.4
-Z	925	6.17	0.77 + 5.4
+Z -Y	930	6.17	0.77 + 5.4

Table 4.1.3-3 PLANCK – TCS Propellant Tanks Lines power

- CRS: added a new line of 24.3 W for each CRS
- DCCU: added a new heater (power value 11.39W) on the same REBA's heater line.
- FOG: power dissipation changed to 16.5W in both BOL and EOL conditions (3 channels)

Controlled Distribution

- Heaters thresholds

A few variations have been introduced; in the following Table 4.1.3-1 a summary of current thresholds for all the TCS lines is given:

TCS Heater Line	Heater location	Thresholds [°C]
01 - 02	close to STR1 and STR2	-19 / -16
03 - 04	close to DPU1 and DPU2	-9 / -6
05	close to REU	-9 / -6
06	close to CCU and CEU	-9 / -6
07	SCC Heat Pipes	-10 / -9
08	SCC Heat Pipes	-11 / -10
09	SCC Heat Pipes	-12 / -11
10	SCC Heat Pipes	-13 / -12
11	SCC Heat Pipes	-14 / -13
12	SCC Heat Pipes	-15 / -14
13	SCC Heat Pipes	-16 / -15
14	Helium Tanks	-9 / -6
15	PAU	-9 / -6
16	CRU (4K Reg)	-9 / -6
17 - 18	CRS1, CRS2	+48/ +48.5
19	CRS3	+35/ +35.5
20 - 21 - 22	Propellant Tanks	+11 / +14
24 - 25 (main) 38 - 39 (red)	1N Thrusters FCV	+14 / +21
26 - 27 - 28 - 29 - 30 - 31 (main) 40 - 41 - 42 - 43 - 44 - 45 (red)	20N Thrusters FCV	+14 / +21
32	RCS Units	+23 / +24
33	RCS pipes	+23 / +24
34	RCS pipes	+27 / +28
35	CAU	-9 / -6
36	REBA1, REBA2, DCCU	-19 / -16
37	BATTERY	+1 / +4
46	RCS pipes	+19 / +20
47	RCS pipes	+19 / +20
48	RCS pipes	+19 / +20

Table 4.1.3-1 PLANCK – TCS Lines Thresholds

- RCS

Update of the RCS model according to [AD28]. It includes linear couplings between RCS and structure, heater power distribution, setting of the thermostat thresholds in order to control every part of the lines within the operative limits; see Par 4.1.4 for details.

4.1.4 PLANCK RCS Model

A new RCS pipelines model has been introduced for TV/TB Test; it is made of 149 nodes (145 for piping and 4 for RCS units). Each typical pipeline node is centered on the relevant pipeline support; a summary of linear and radiative couplings to structure is given in Table 4.1.4-1.

Linear Couplings	RCS Nodes	GL [W/K]	remarks
Single RCS line / Structure	1800 to 1952	0.004	Local variations for nodes near TP, FVV, FDV
Double RCS Line / Structure		0.007	
RCS line / tanks		0.01	
RCS line / Thrusters FCV		0.01	
LV / -Z+Y shear panel	1840, 1841	0.0428	
LF / -Z+Y shear panel	1842	0.01937	
PT / -Z+Y shear panel	1843	0.0317	
Pipes Radiative Couplings	RCS Nodes	GR [W/K ⁴]	remarks
Single RCS line, 20 cm / Structure	1800 to 1952	2.49E-11	Local variations for nodes near tanks
Single RCS line, 30 cm / Structure		3.74E-11	
Double RCS line, 20 cm / Structure		4.98E-11	
Double RCS line, 30 cm / Structure		7.48E-11	

Table 4.1.4-1 PLANCK – RCS model summary

In the following figures a sketch of RCS nodes is given, as well as the current position of each line's thermistor:

RCS Line	THM id	THM id	THM id	THM position in TMM	remarks
32	80	128	176	1843	on PT
33	81	129	177	1812	
34	82	130	178	1827	
46	94	142	190	1874	
47	95	143	191	1884	new position
48	96	144	192	1941	new position

Table 4.1.4-2 PLANCK – RCS Thermistors positions

Controlled Distribution

REFERENCE : H-P-RP-AI-0040

DATE : 29/SEP/06

ISSUE : 06

Page : 82/405

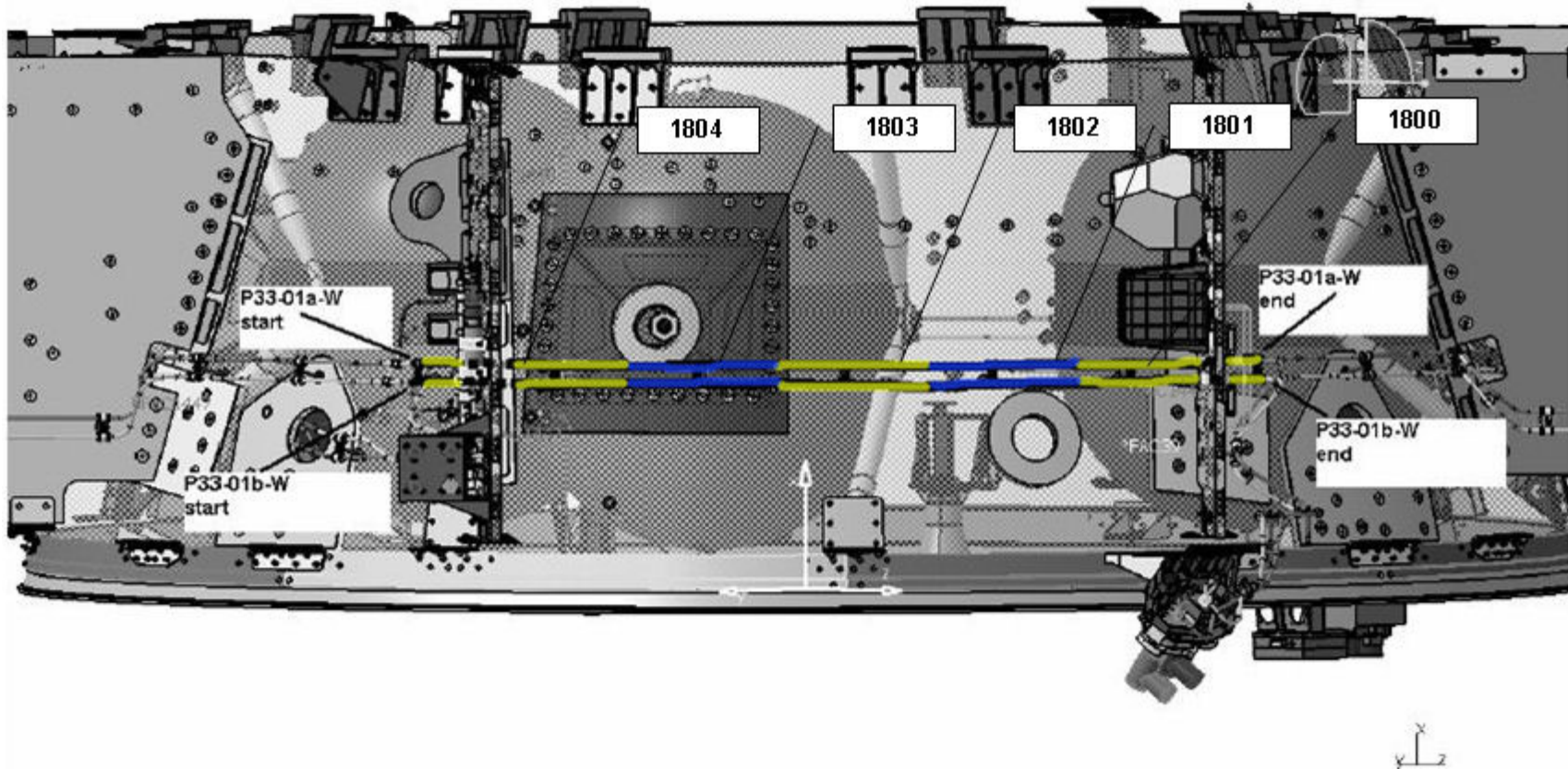

Figure 4.1.4-1 PLANCK - RCS Line #33



Controlled Distribution

REFERENCE : H-P-RP-AI-0040

DATE : 29/SEP/06

ISSUE : 06

Page : 83/405

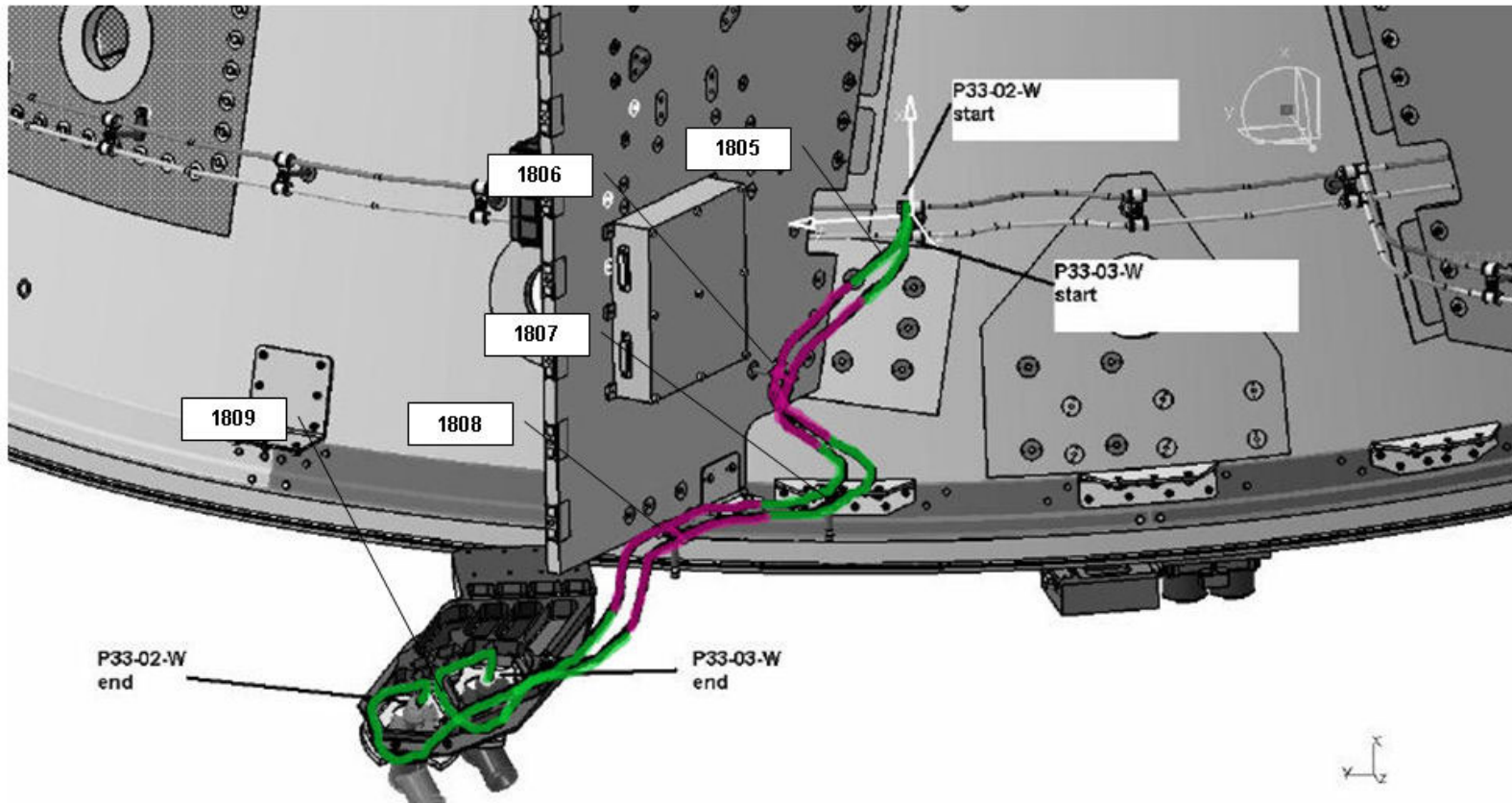

Figure 4.1.4-2 PLANCK - RCS Line #33



All rights reserved © Alcatel Alenia Space All rights reserved

M032-6_EN

Controlled Distribution

REFERENCE : H-P-RP-AI-0040

DATE : 29/SEP/06

ISSUE : 06

Page : 84/405

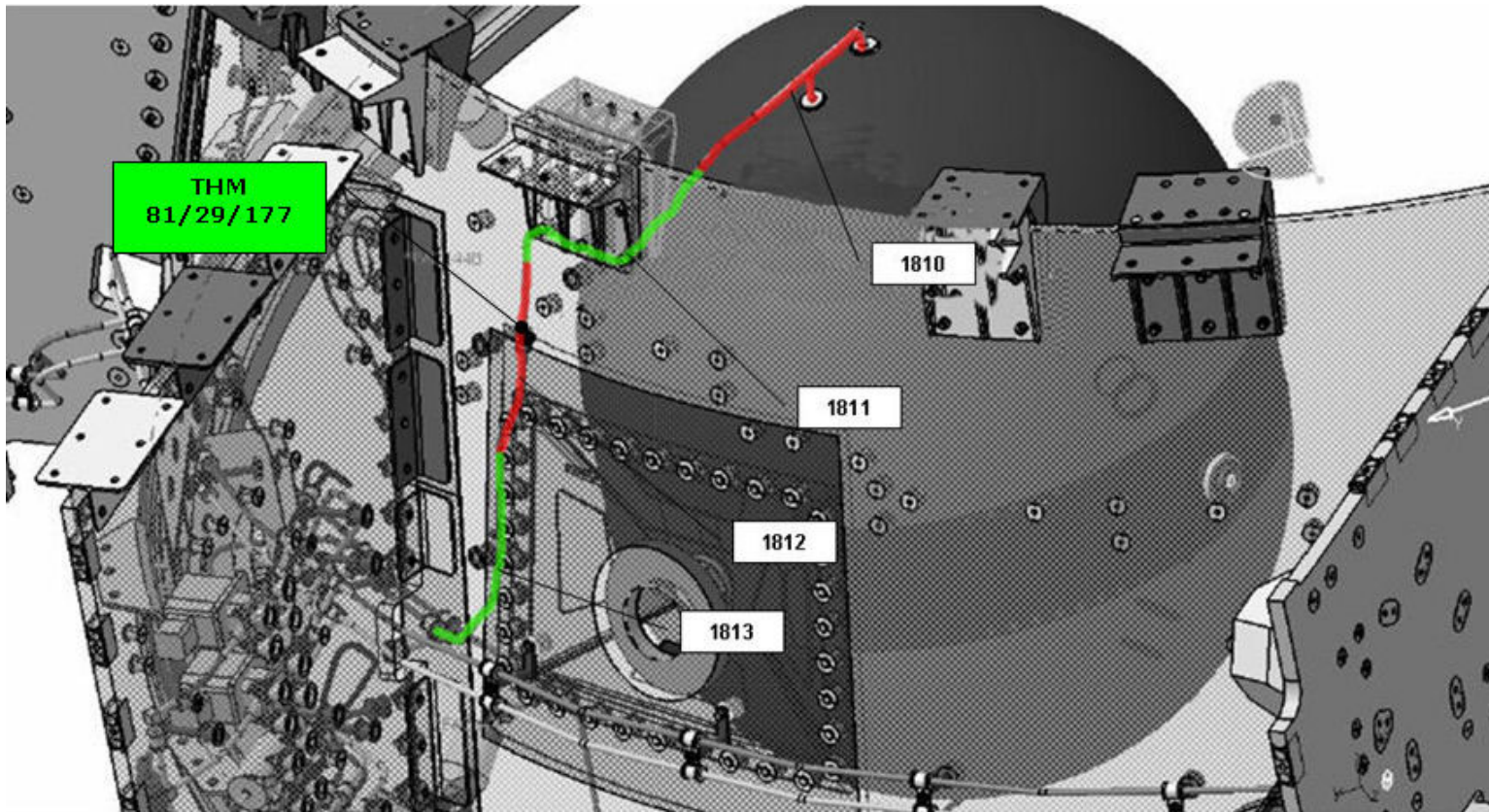

Figure 4.1.4-3 PLANCK - RCS Line #33



Controlled Distribution

REFERENCE : H-P-RP-AI-0040

DATE : 29/SEP/06

ISSUE : 06

Page : 85/405

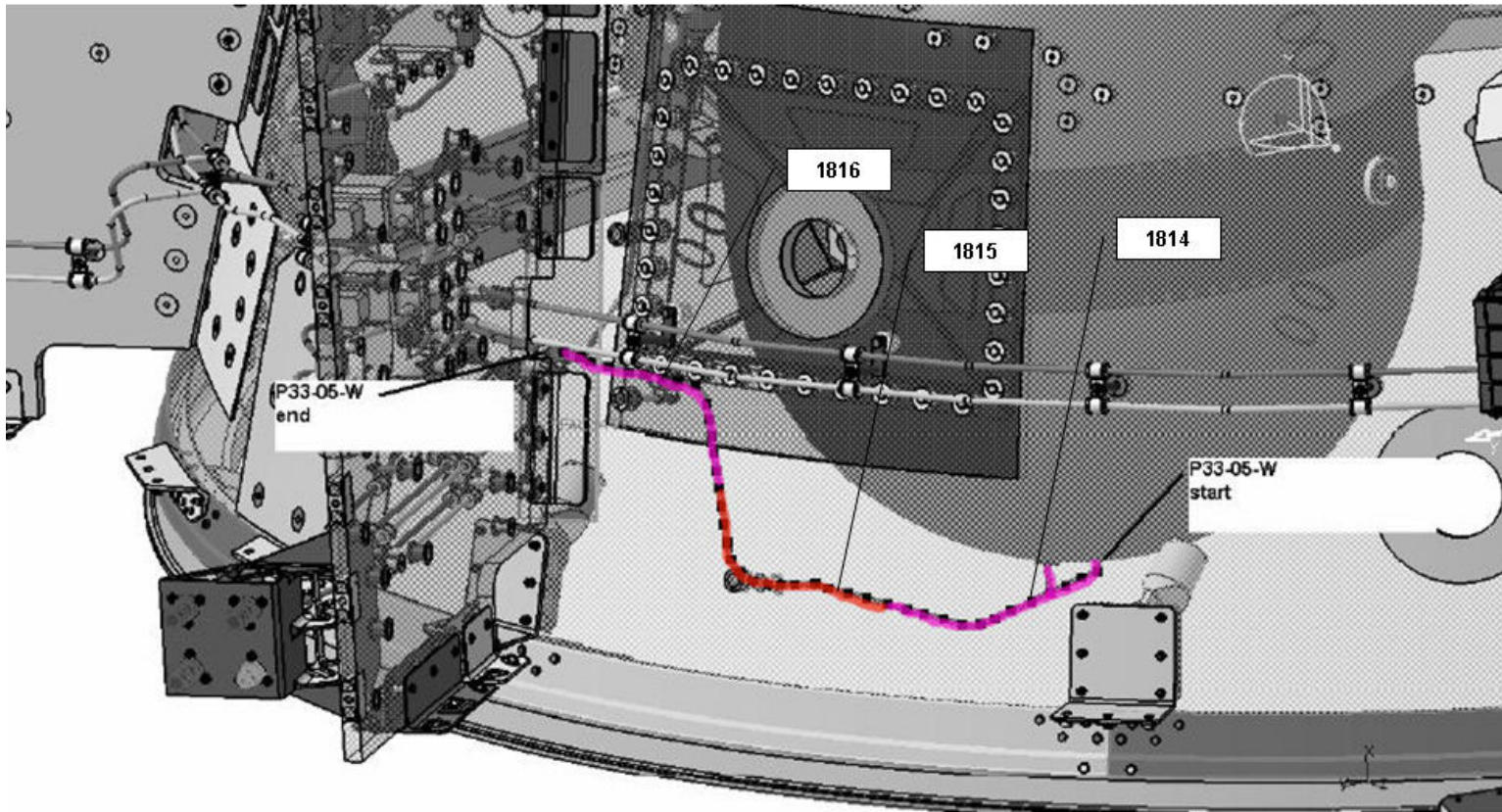

Figure 4.1.4-4 PLANCK - RCS Line #33



All rights reserved © Alcatel Alenia Space All rights reserved

M032-6_EN

Controlled Distribution

Controlled Distribution

REFERENCE : H-P-RP-AI-0040

DATE : 29/SEP/06

ISSUE : 06

Page : 86/405

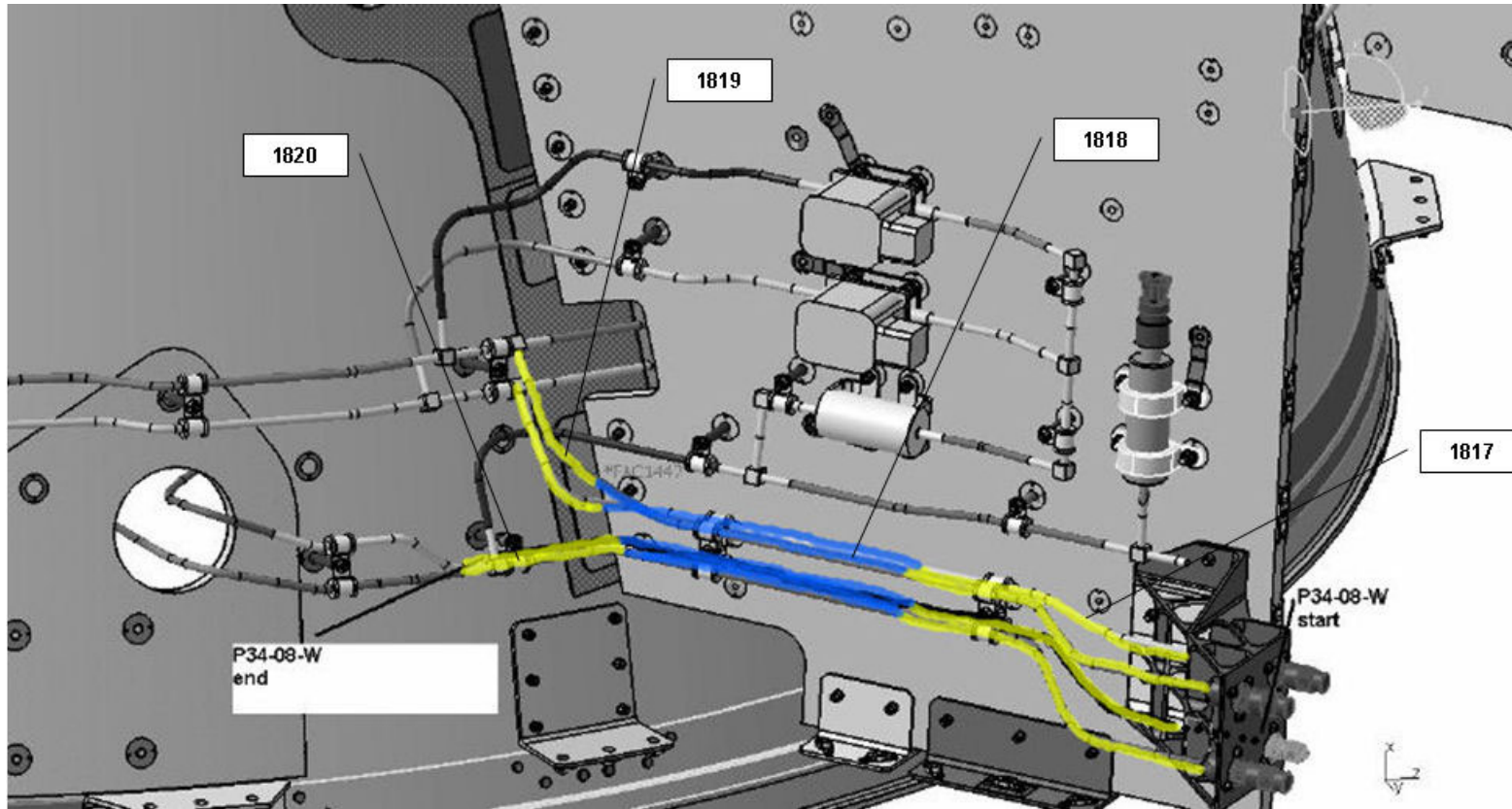

Figure 4.1.4-5 PLANCK - RCS Line #34



Controlled Distribution

REFERENCE : H-P-RP-AI-0040

DATE : 29/SEP/06

ISSUE : 06

Page : 87/405

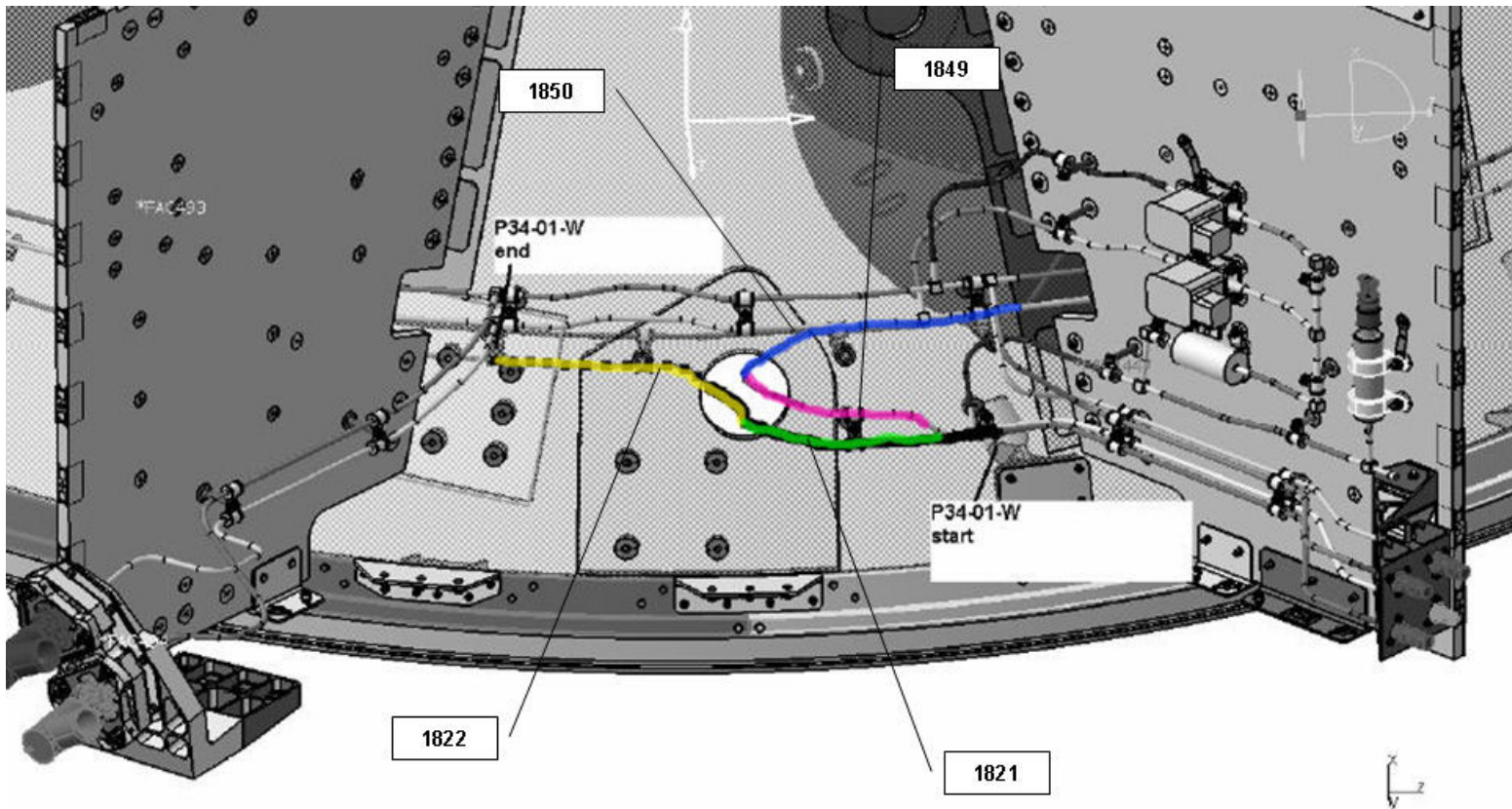

Figure 4.1.4-6 PLANCK - RCS Line #34

Controlled Distribution

REFERENCE : H-P-RP-AI-0040

DATE : 29/SEP/06

ISSUE : 06

Page : 88/405

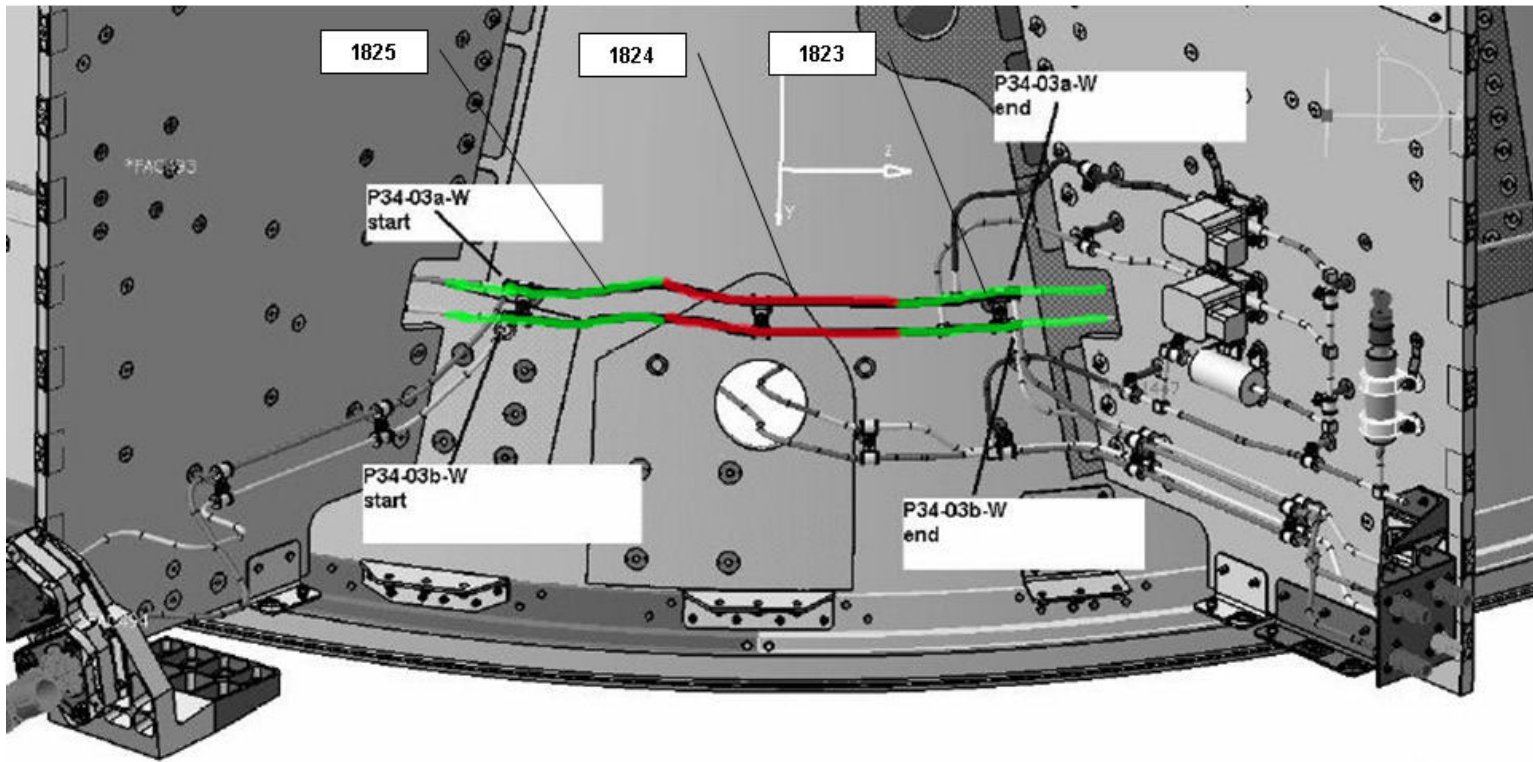

Figure 4.1.4-7 PLANCK - RCS Line #34



All rights reserved © Alcatel Alenia Space All rights reserved

M032-6_EN

Controlled Distribution

REFERENCE : H-P-RP-AI-0040

DATE : 29/SEP/06

ISSUE : 06

Page : 89/405

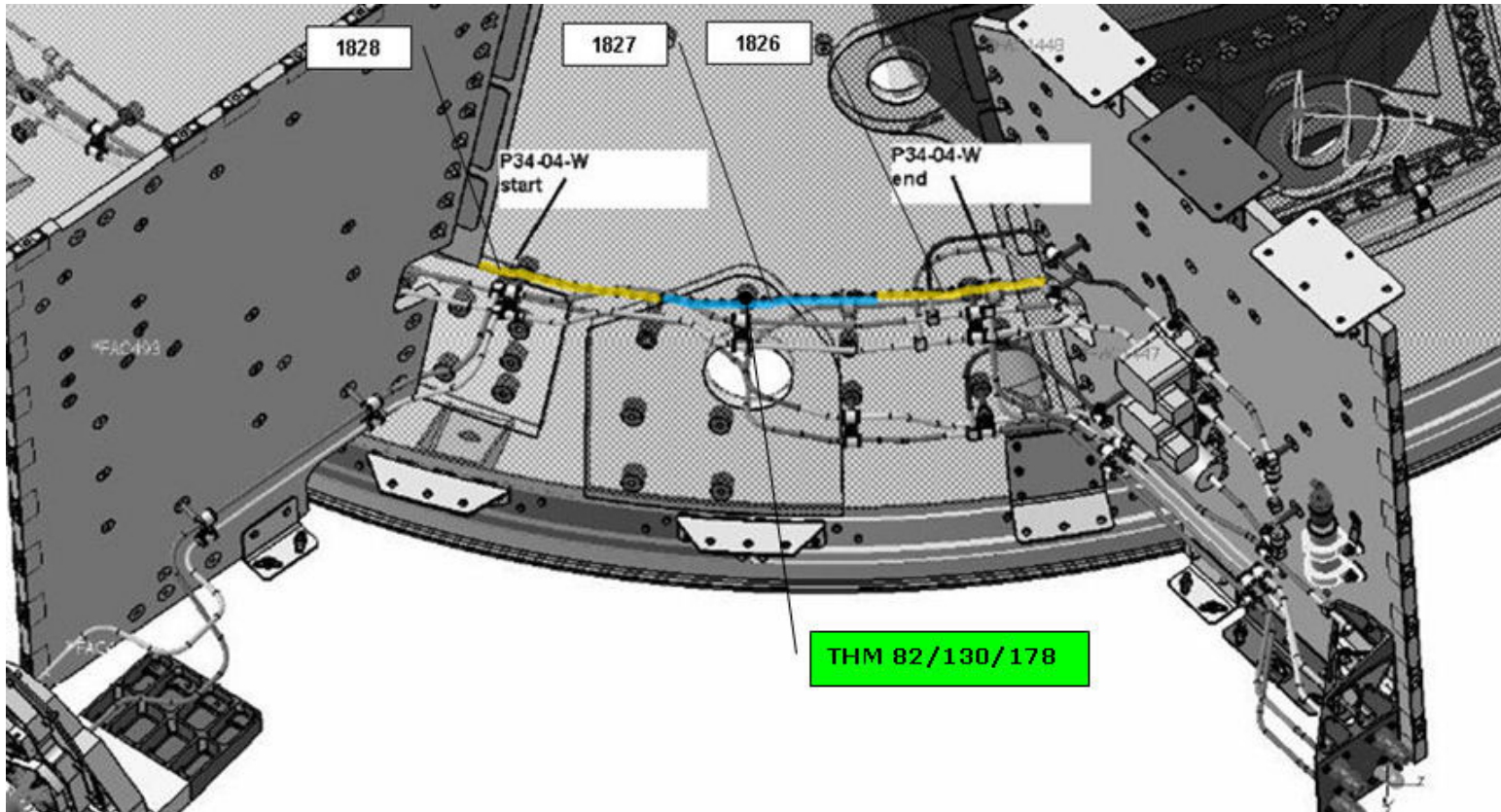

Figure 4.1.4-8 PLANCK - RCS Line #34



Controlled Distribution

REFERENCE : H-P-RP-AI-0040

DATE : 29/SEP/06

ISSUE : 06

Page : 90/405

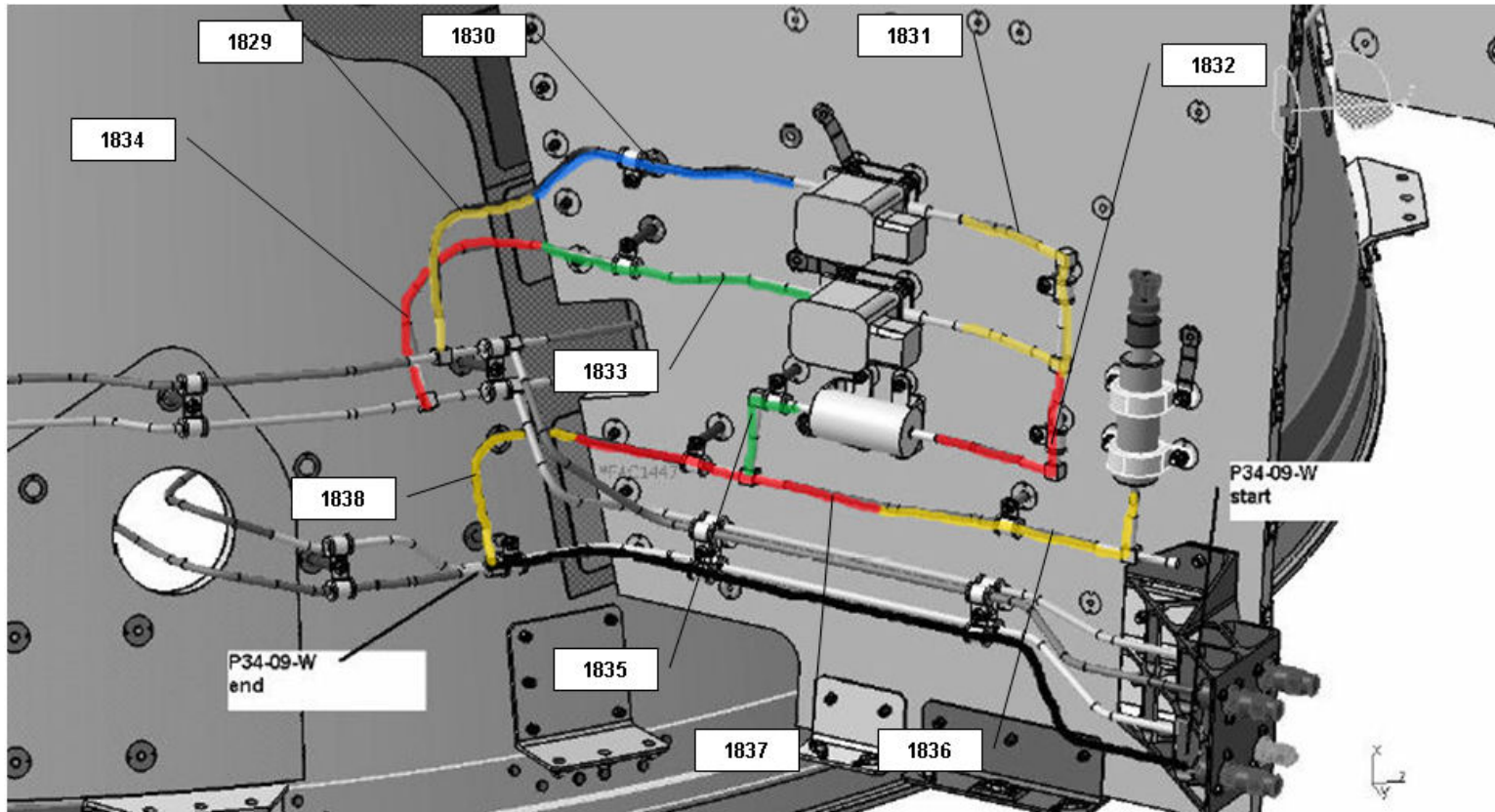

Figure 4.1.4-9 PLANCK - RCS Line #34



Controlled Distribution

REFERENCE : H-P-RP-AI-0040

DATE : 29/SEP/06

ISSUE : 06

Page : 91/405

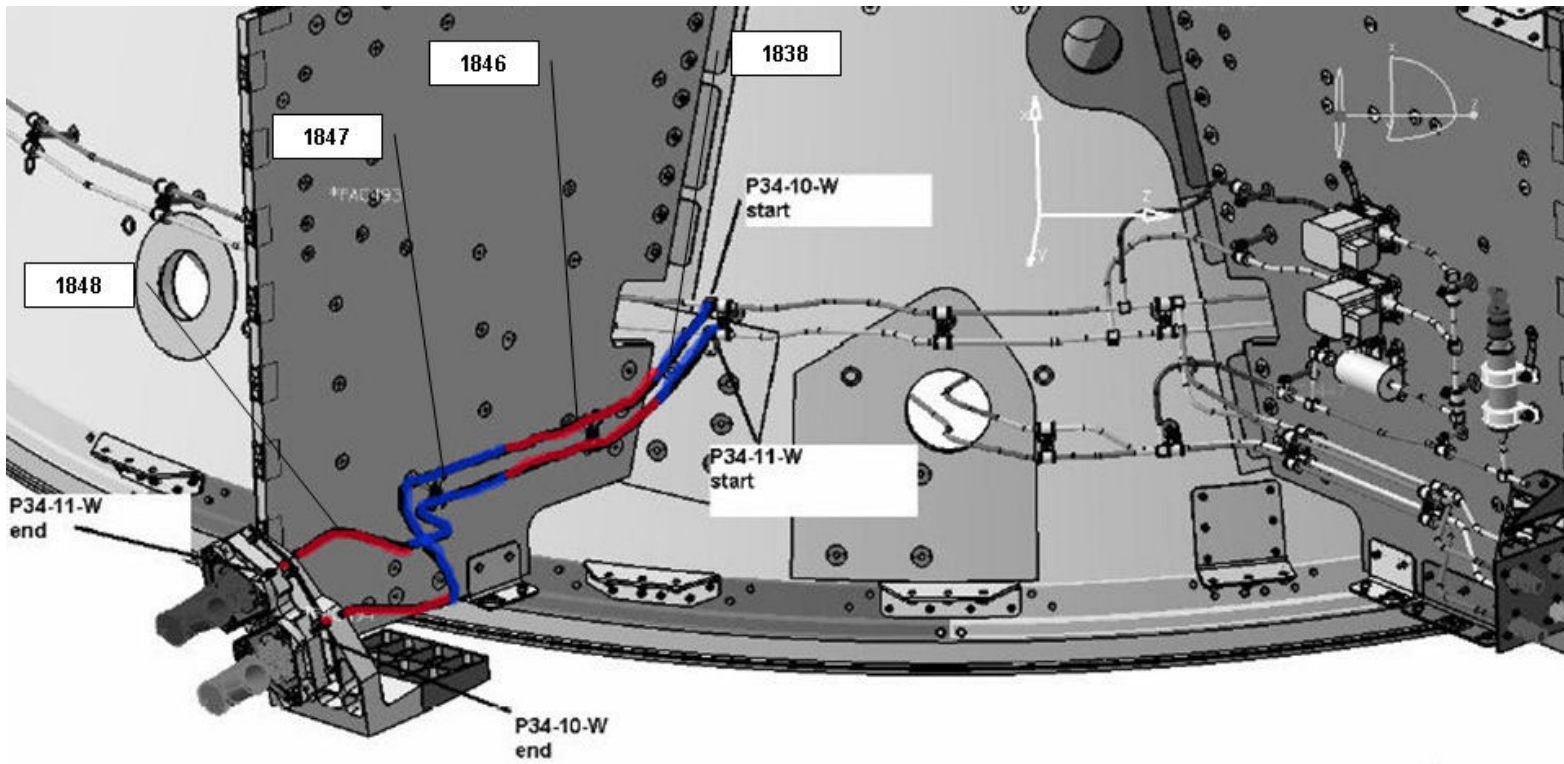

Figure 4.1.4-10 PLANCK - RCS Line #34



Controlled Distribution

REFERENCE : H-P-RP-AI-0040

DATE : 29/SEP/06

ISSUE : 06

Page : 92/405

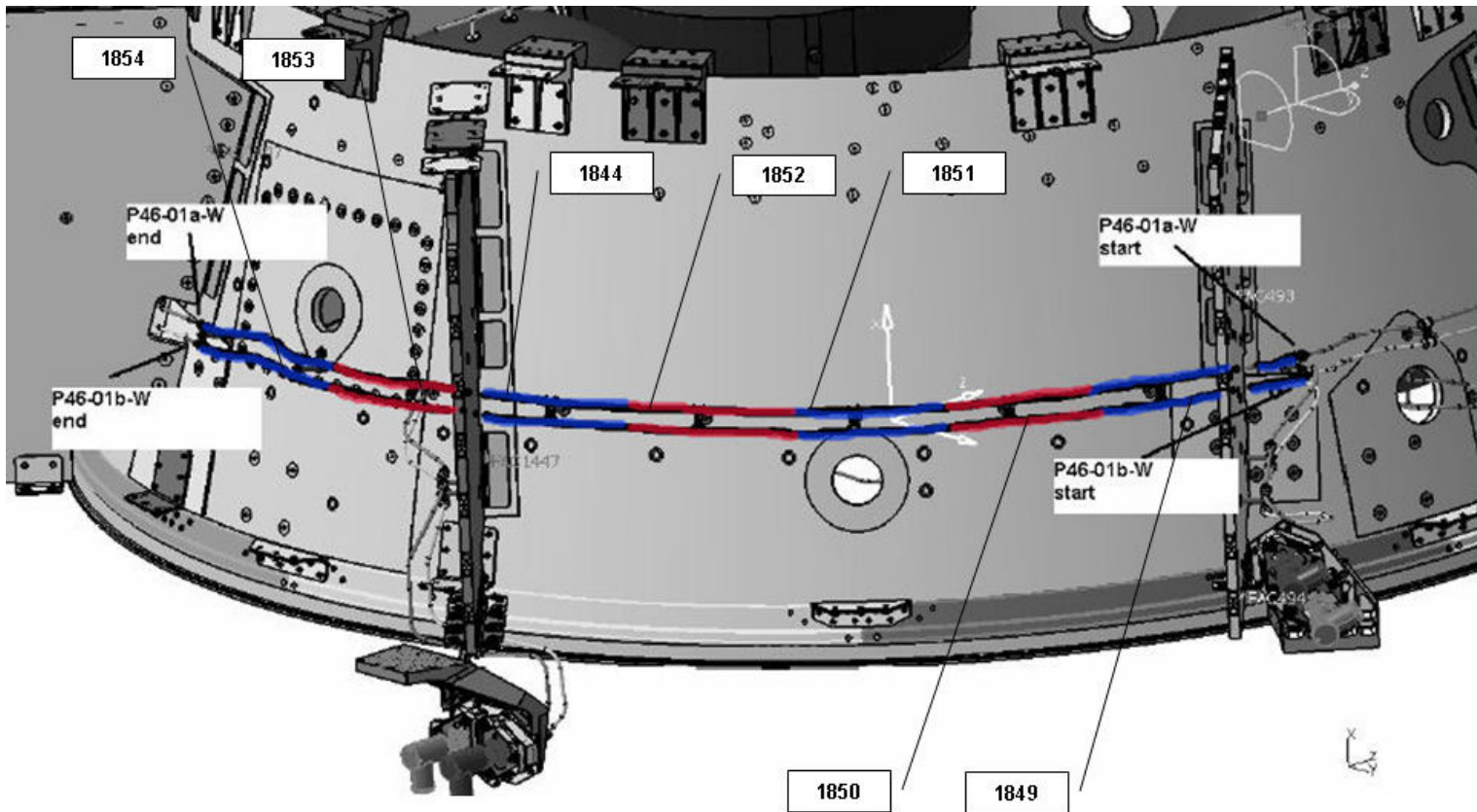

Figure 4.1.4-11 PLANCK - RCS Line #46



All rights reserved © Alcatel Alenia Space All rights reserved

M032-6_EN

Controlled Distribution

Controlled Distribution

REFERENCE : H-P-RP-AI-0040

DATE : 29/SEP/06

ISSUE : 06

Page : 93/405

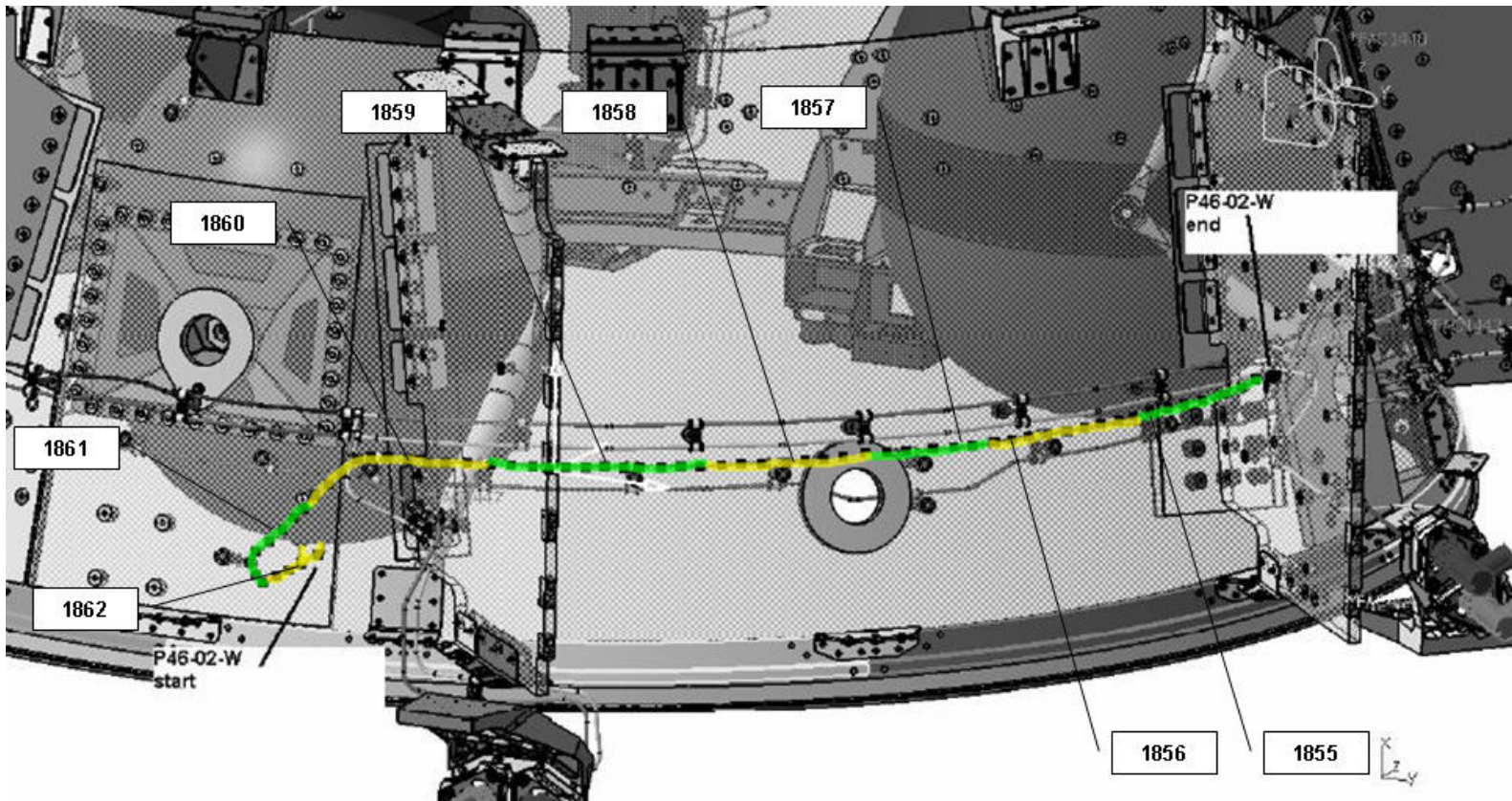

Figure 4.1.4-12 PLANCK - RCS Line #46



All rights reserved © Alcatel Alenia Space All rights reserved

M032-6_EN

Controlled Distribution

Controlled Distribution

REFERENCE : H-P-RP-AI-0040

DATE : 29/SEP/06

ISSUE : 06

Page : 94/405

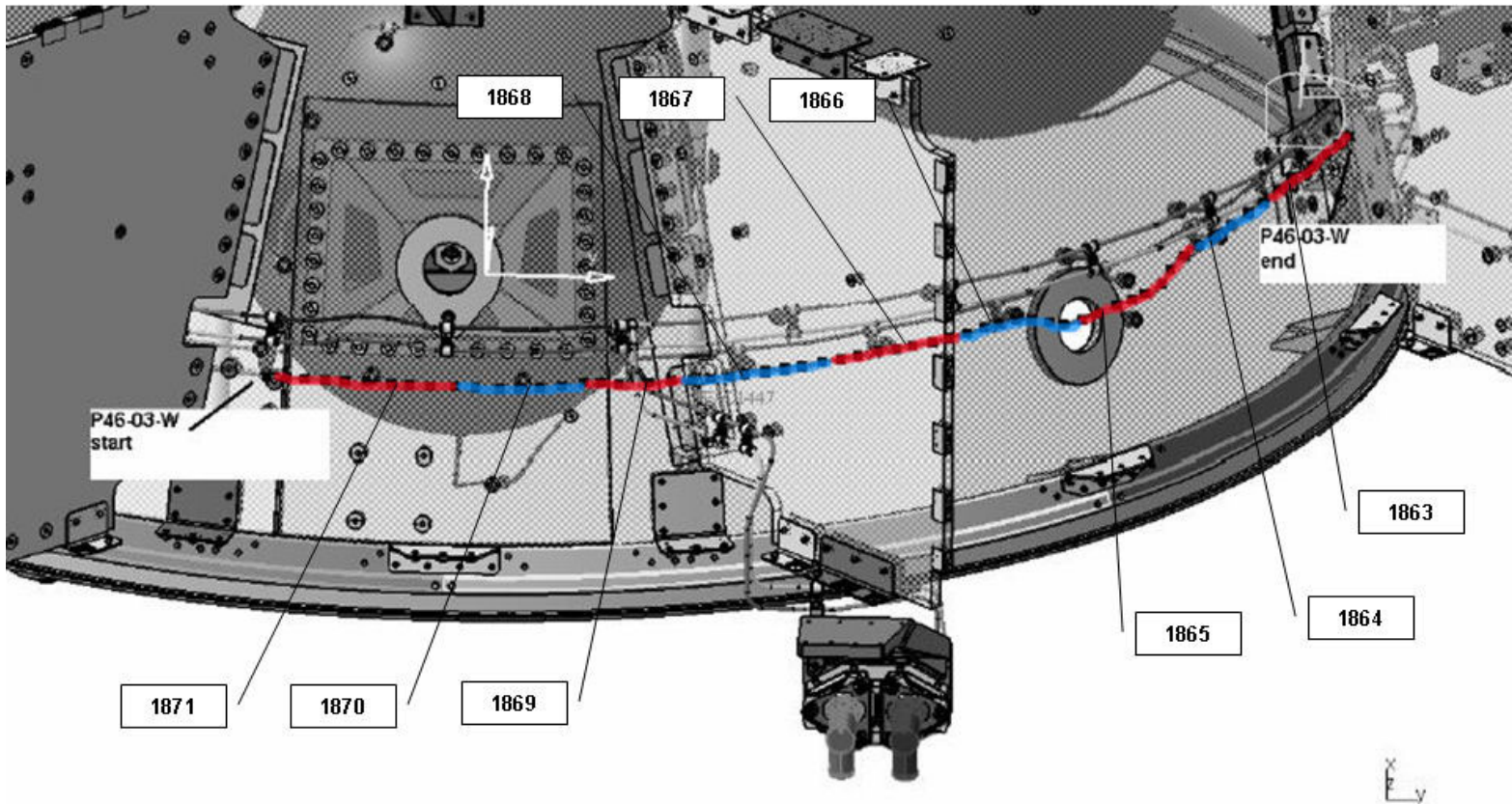

Figure 4.1.4-13 PLANCK - RCS Line #46



Controlled Distribution

REFERENCE : H-P-RP-AI-0040

DATE : 29/SEP/06

ISSUE : 06

Page : 95/405

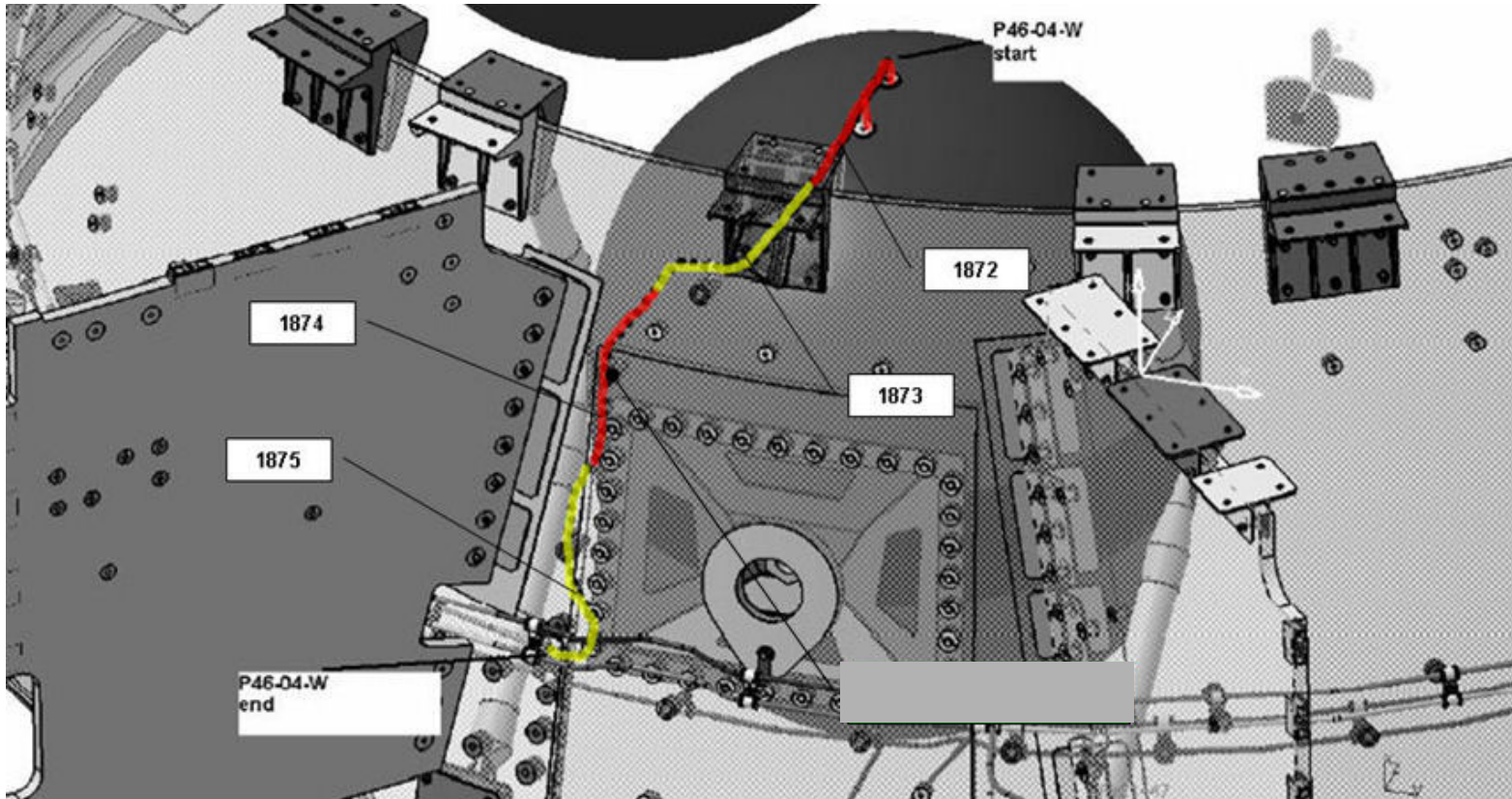

Figure 4.1.4-14 PLANCK - RCS Line #46



Controlled Distribution

REFERENCE : H-P-RP-AI-0040

DATE : 29/SEP/06

ISSUE : 06

Page : 96/405

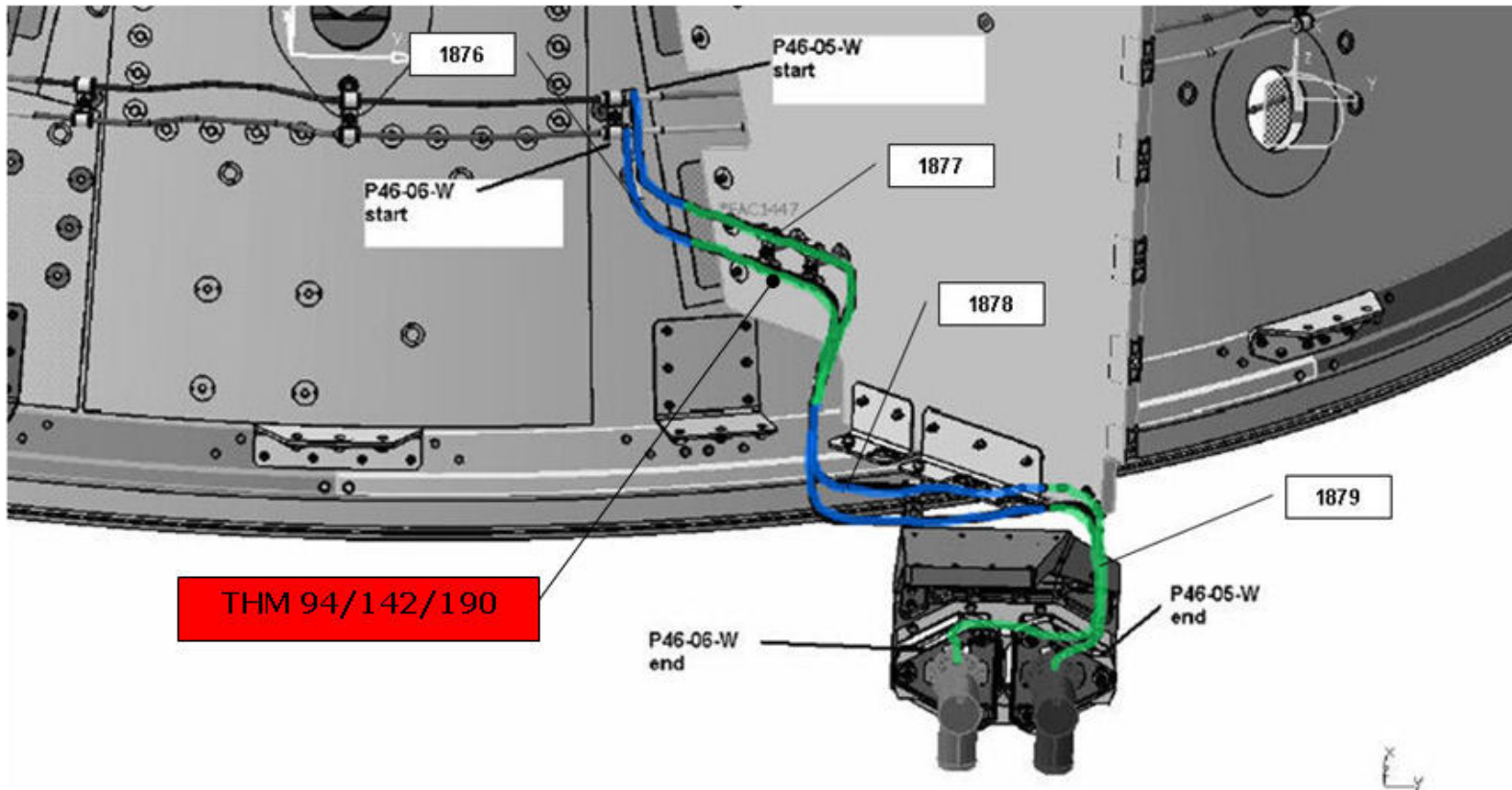

Figure 4.1.4-15 PLANCK - RCS Line #46



Controlled Distribution

REFERENCE : H-P-RP-AI-0040

DATE : 29/SEP/06

ISSUE : 06

Page : 97/405

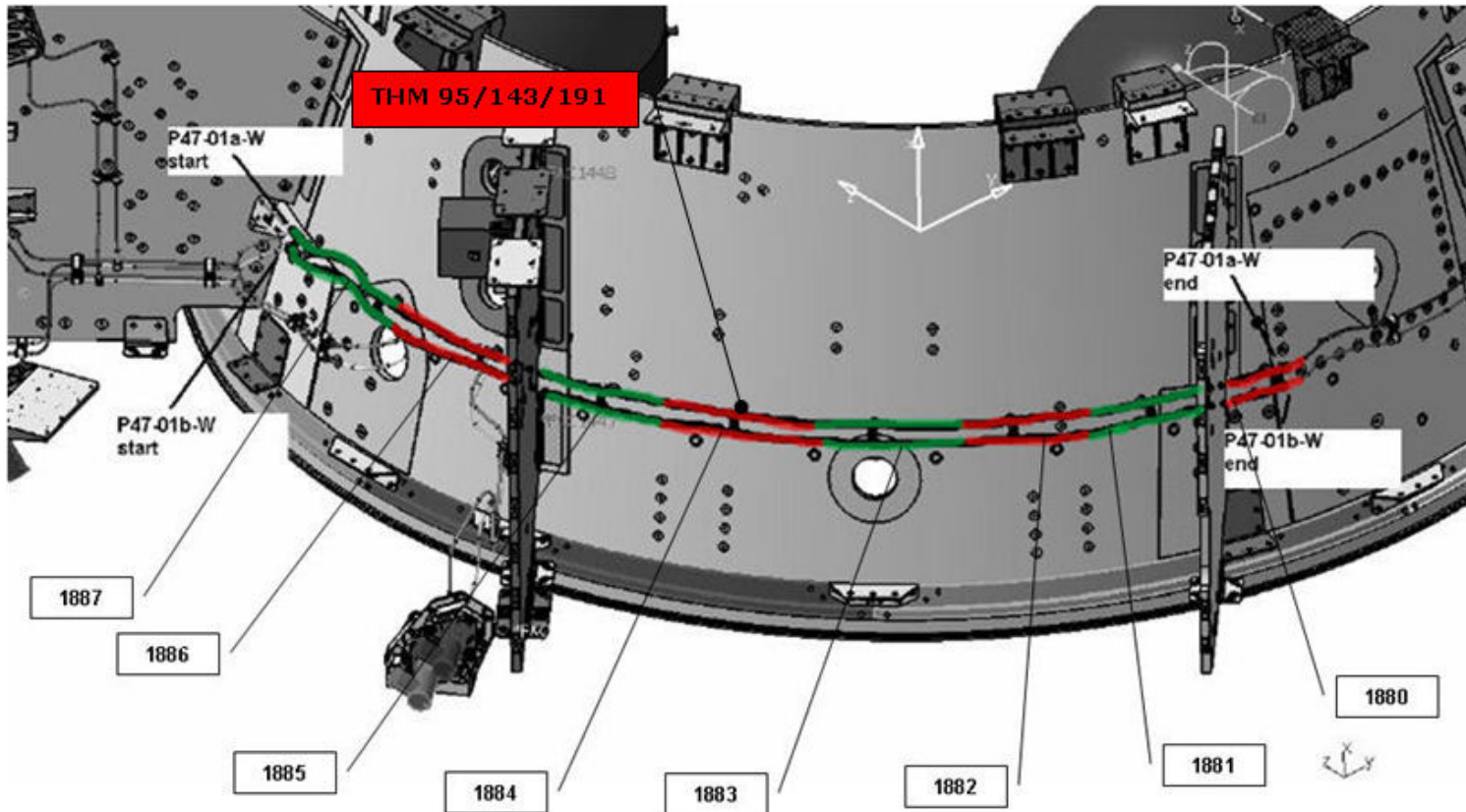

Figure 4.1.4-16 PLANCK - RCS Line #47



Controlled Distribution

REFERENCE : H-P-RP-AI-0040

DATE : 29/SEP/06

ISSUE : 06

Page : 98/405

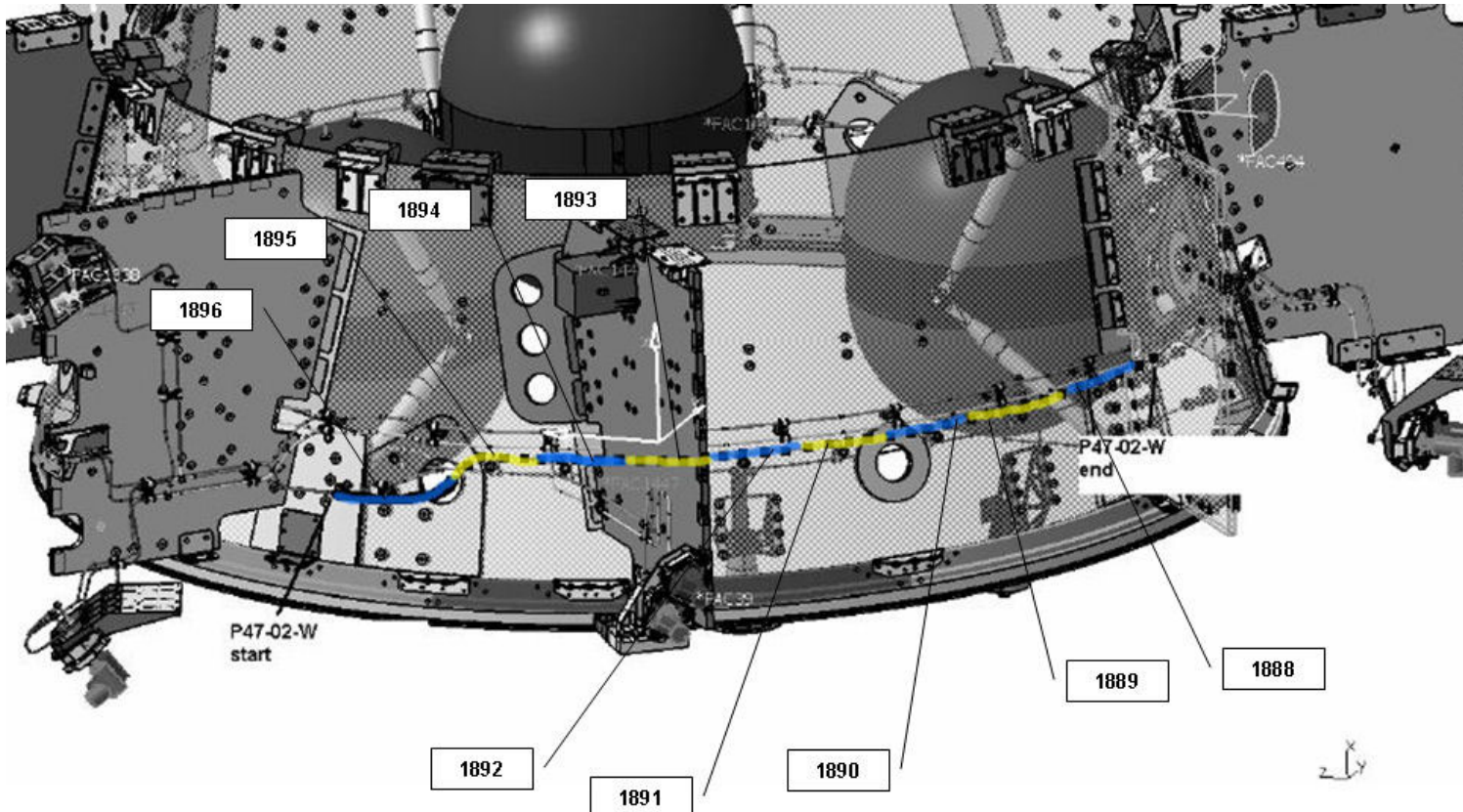

Figure 4.1.4-17 PLANCK - RCS Line #47



All rights reserved © Alcatel Alenia Space All rights reserved

M032-6_EN

Controlled Distribution

REFERENCE : H-P-RP-AI-0040

DATE : 29/SEP/06

ISSUE : 06

Page : 99/405

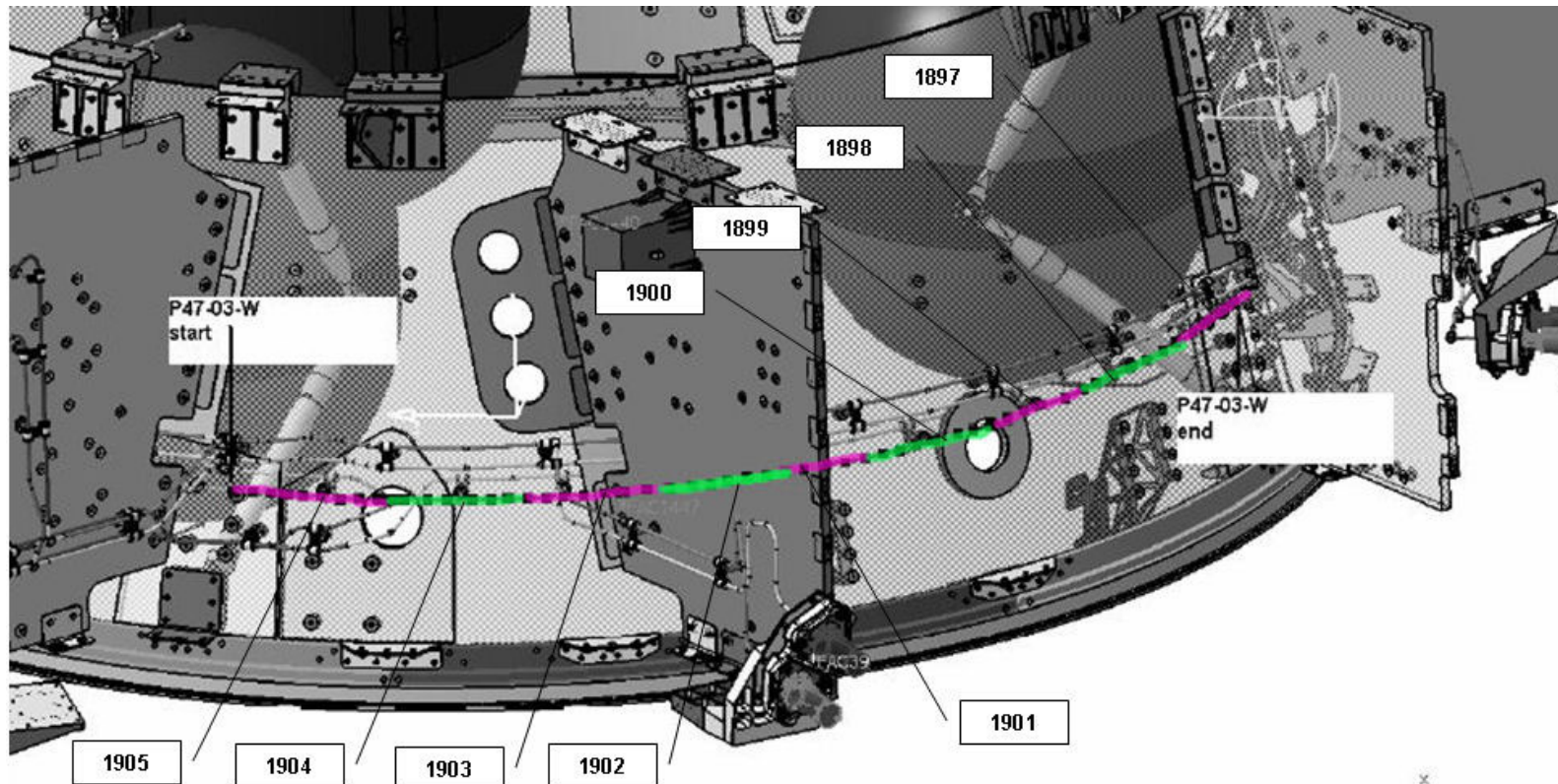

Figure 4.1.4-18 PLANCK - RCS Line #47

ALCATEL

All rights reserved © Alcatel Alenia Space All rights reserved

M032-6_EN

Controlled Distribution

REFERENCE : H-P-RP-AI-0040

DATE : 29/SEP/06

ISSUE : 06

Page : 100/405

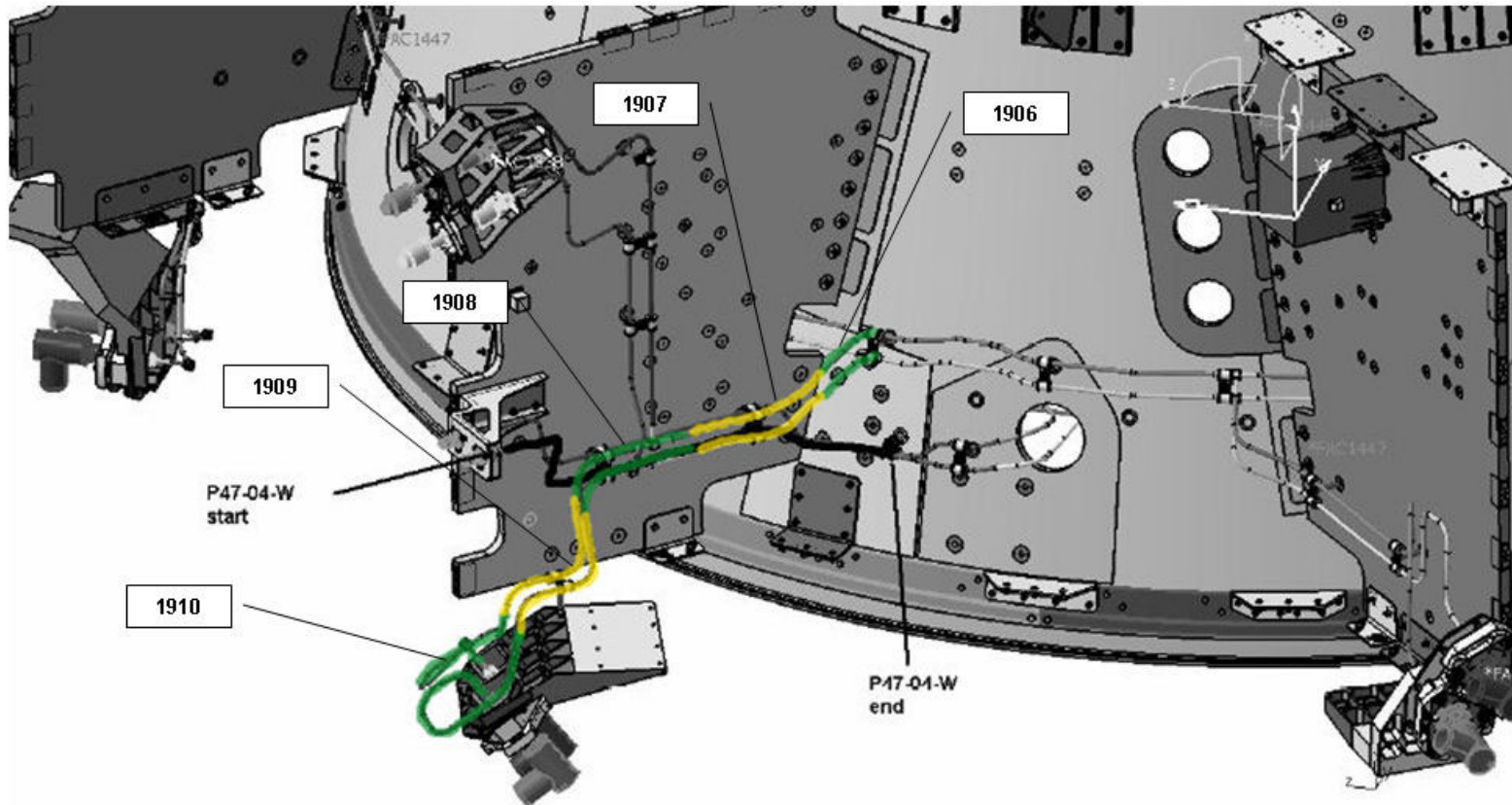

Figure 4.1.4-19 PLANCK - RCS Line #47



All rights reserved © Alcatel Alenia Space All rights reserved

M032-6_EN

Controlled Distribution

Controlled Distribution

REFERENCE : H-P-RP-AI-0040

DATE : 29/SEP/06

ISSUE : 06

Page : 101/405

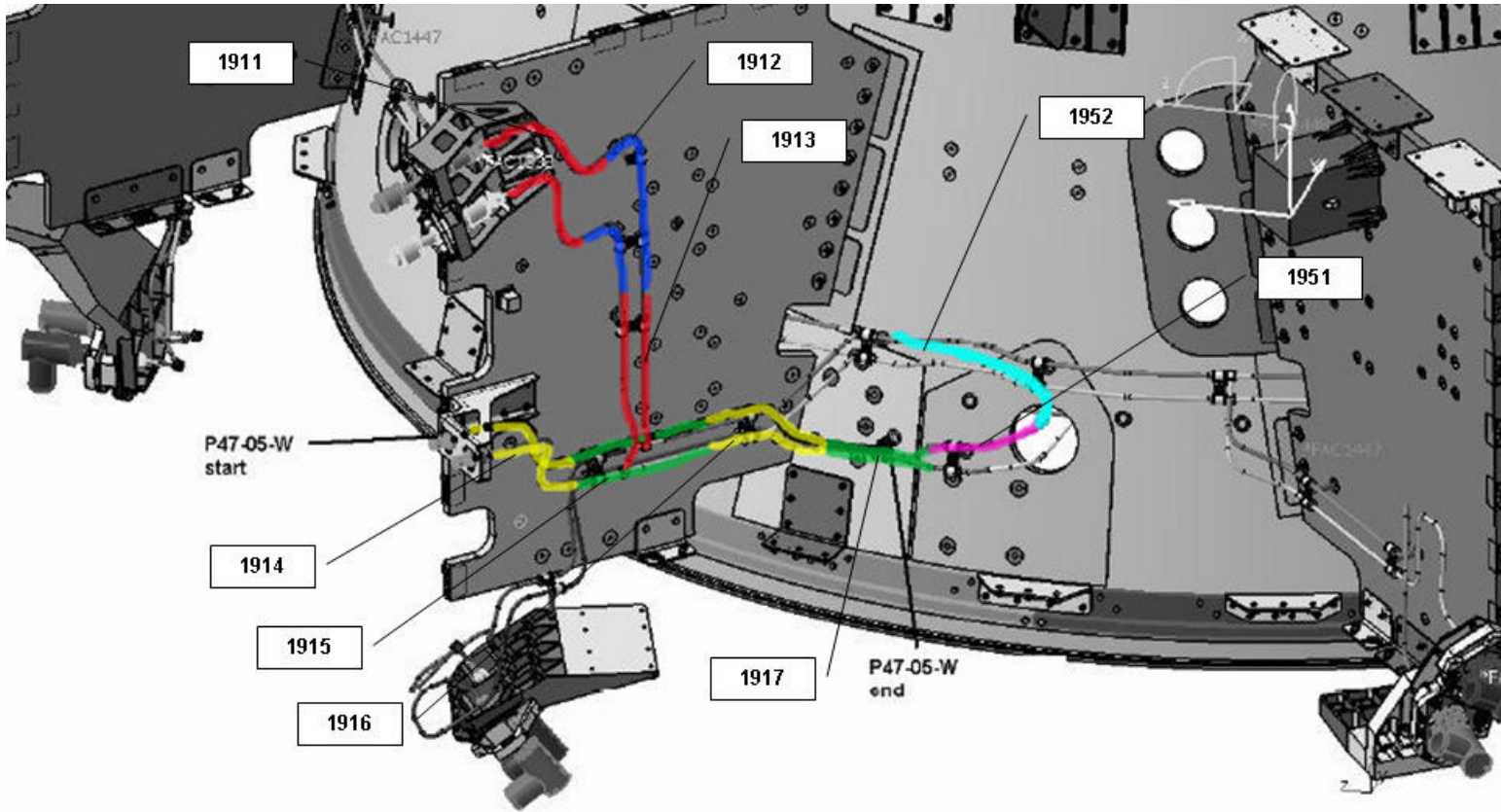

Figure 4.1.4-20 PLANCK - RCS Line #47



Controlled Distribution

REFERENCE : H-P-RP-AI-0040

DATE : 29/SEP/06

ISSUE : 06

Page : 102/405

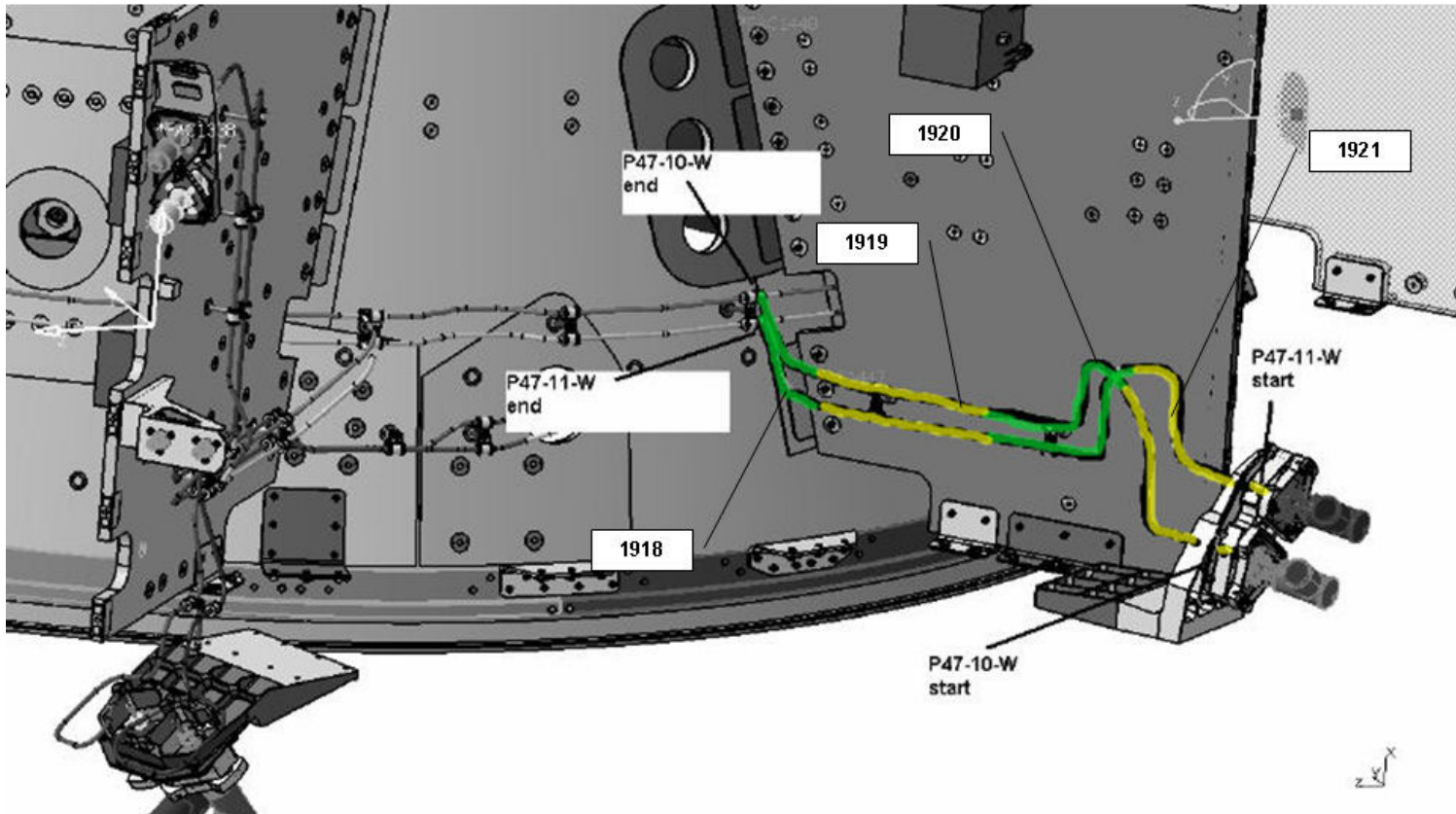

Figure 4.1.4-21 PLANCK - RCS Line #47



Controlled Distribution

REFERENCE : H-P-RP-AI-0040

DATE : 29/SEP/06

ISSUE : 06

Page : 103/405

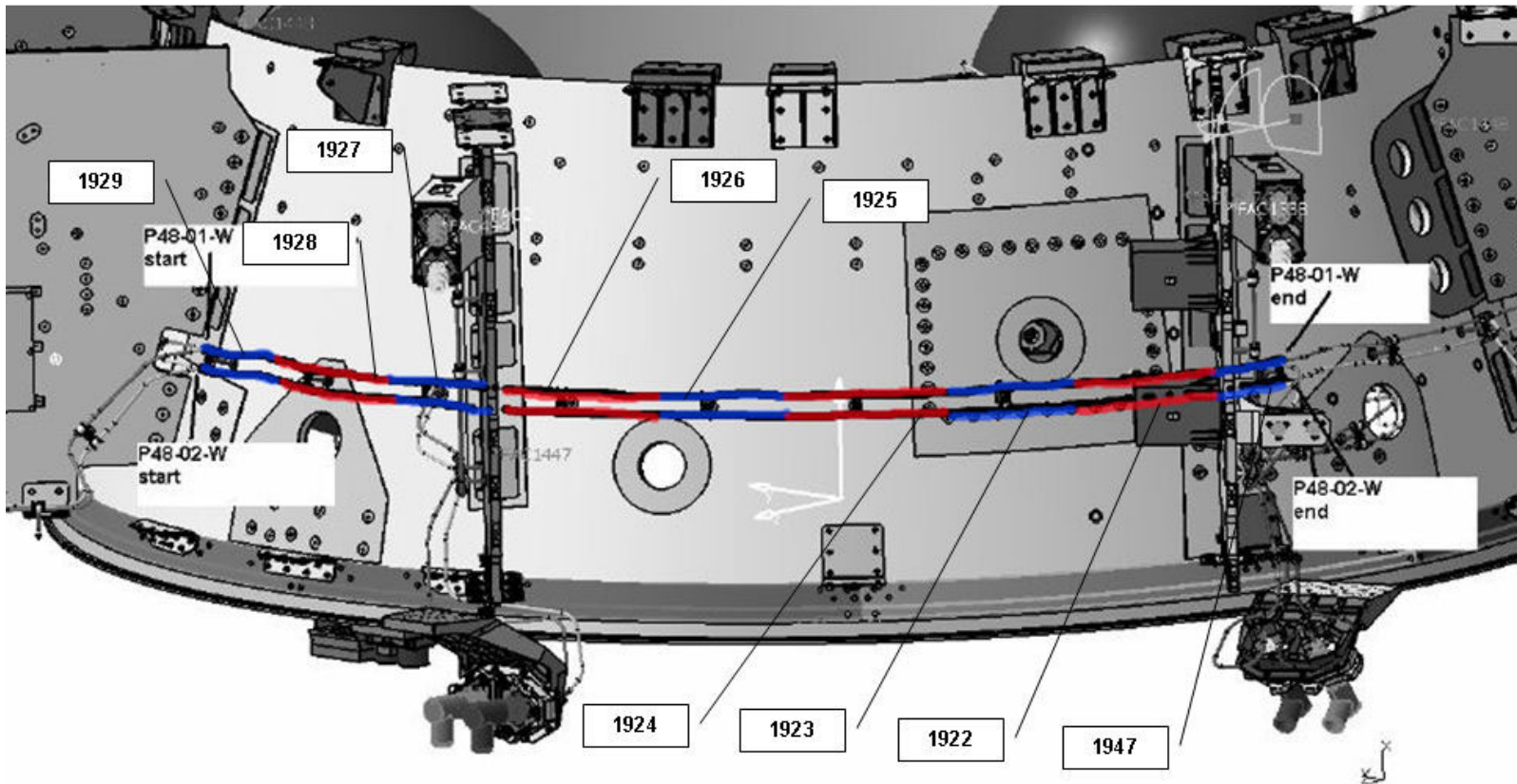

Figure 4.1.4-22 PLANCK - RCS Line #48



Controlled Distribution

REFERENCE : H-P-RP-AI-0040

DATE : 29/SEP/06

ISSUE : 06

Page : 104/405

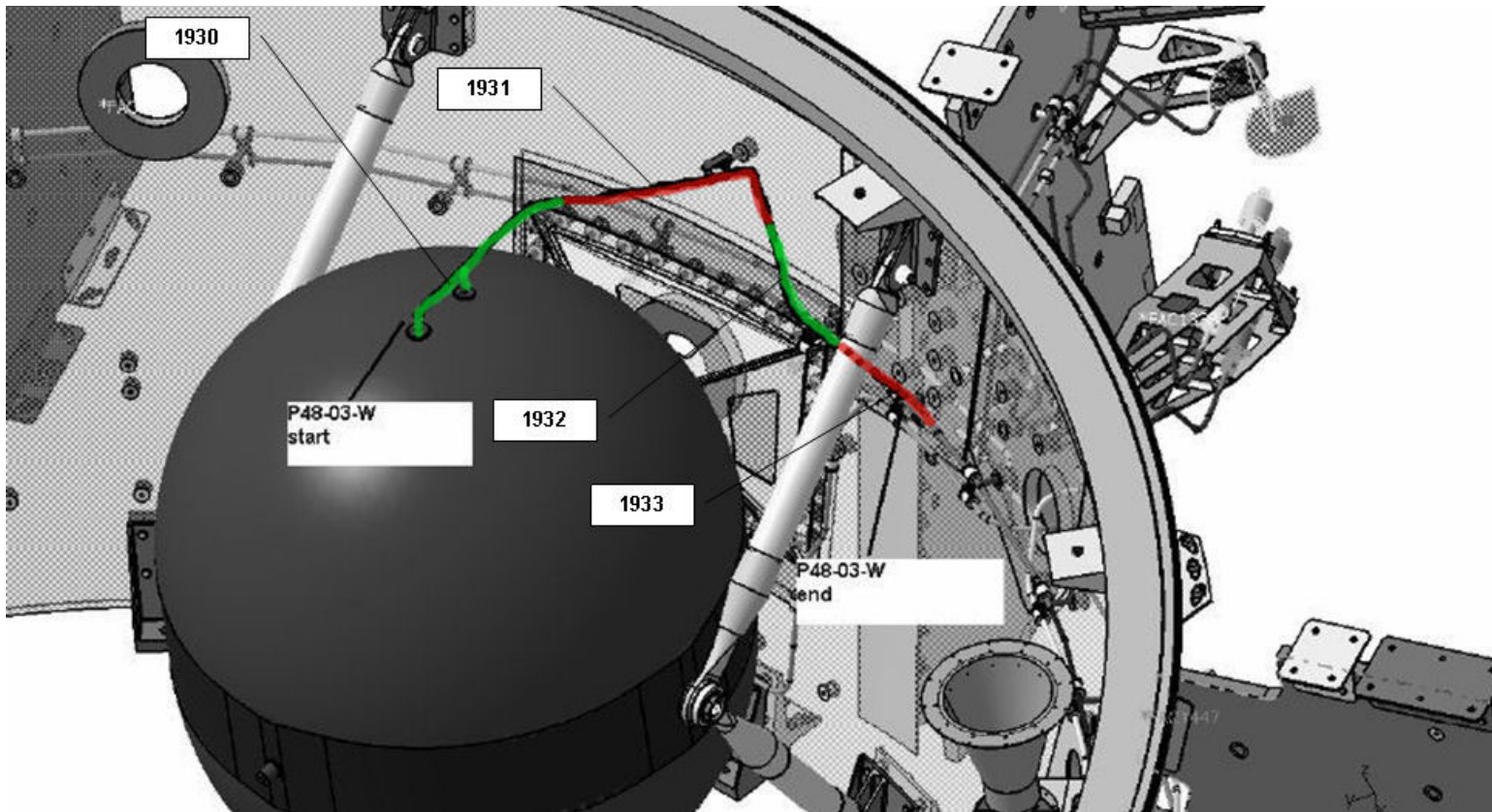

Figure 4.1.4-23 PLANCK - RCS Line #48



Controlled Distribution

REFERENCE : H-P-RP-AI-0040

DATE : 29/SEP/06

ISSUE : 06

Page : 105/405

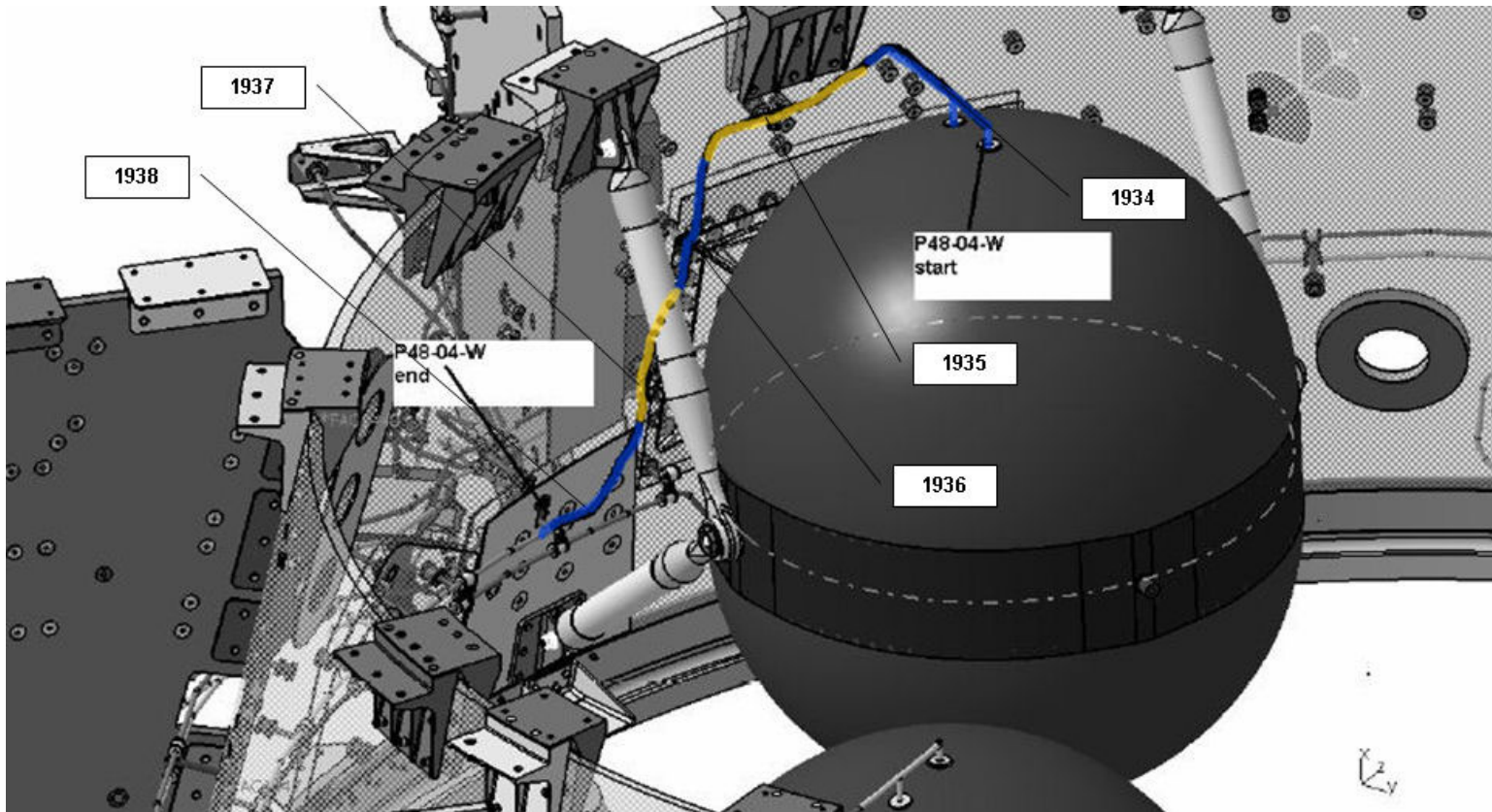

Figure 4.1.4-24 PLANCK - RCS Line #48



All rights reserved © Alcatel Alenia Space All rights reserved

M032-6_EN

Controlled Distribution

Controlled Distribution

REFERENCE : H-P-RP-AI-0040

DATE : 29/SEP/06

ISSUE : 06

Page : 106/405

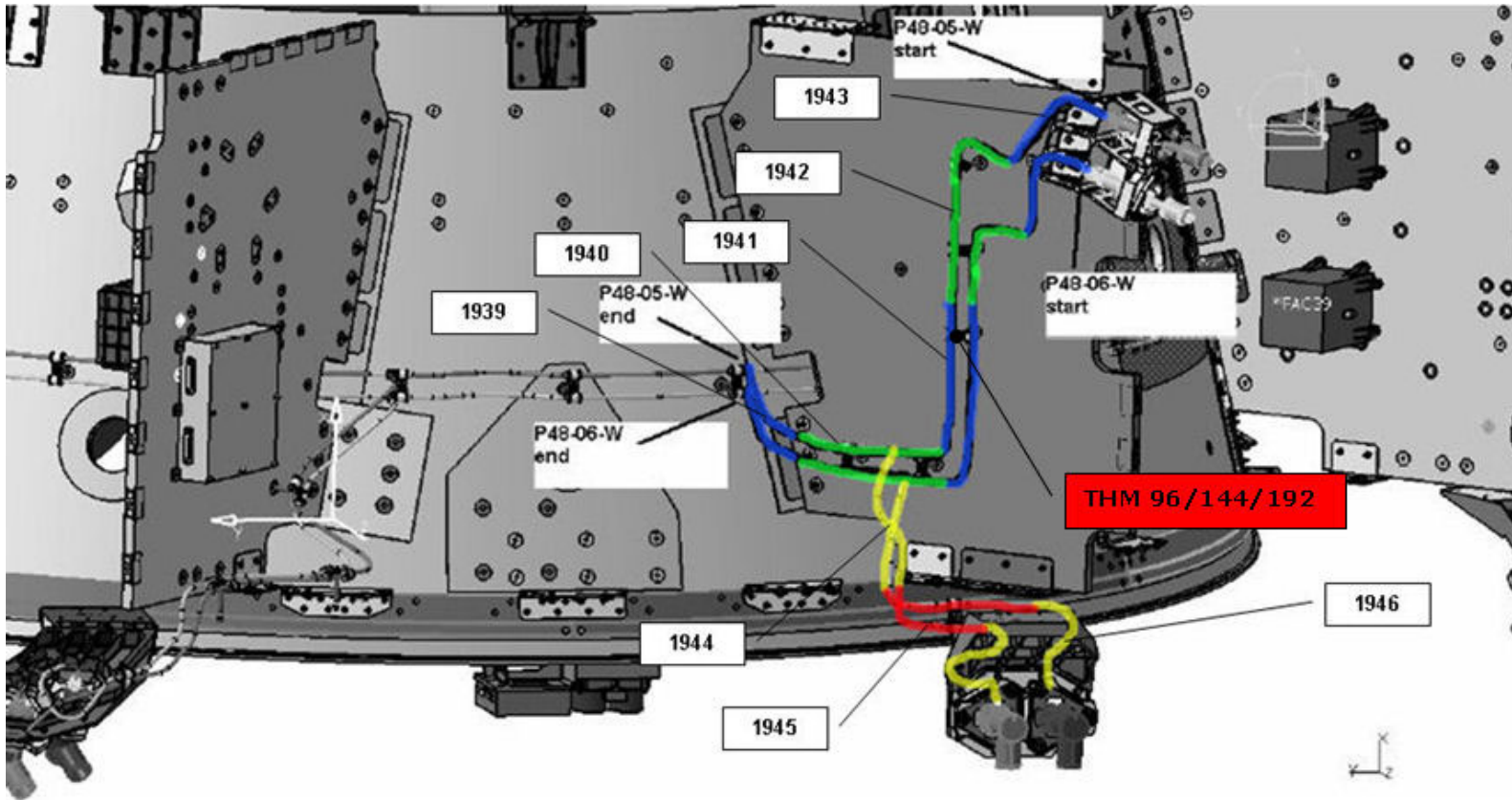

Figure 4.1.4-25 PLANCK - RCS Line #48



All rights reserved © Alcatel Alenia Space All rights reserved

M032-6_EN

Controlled Distribution

Controlled Distribution

REFERENCE : H-P-RP-AI-0040

DATE : 29/SEP/06

ISSUE : 06

Page : 107/405

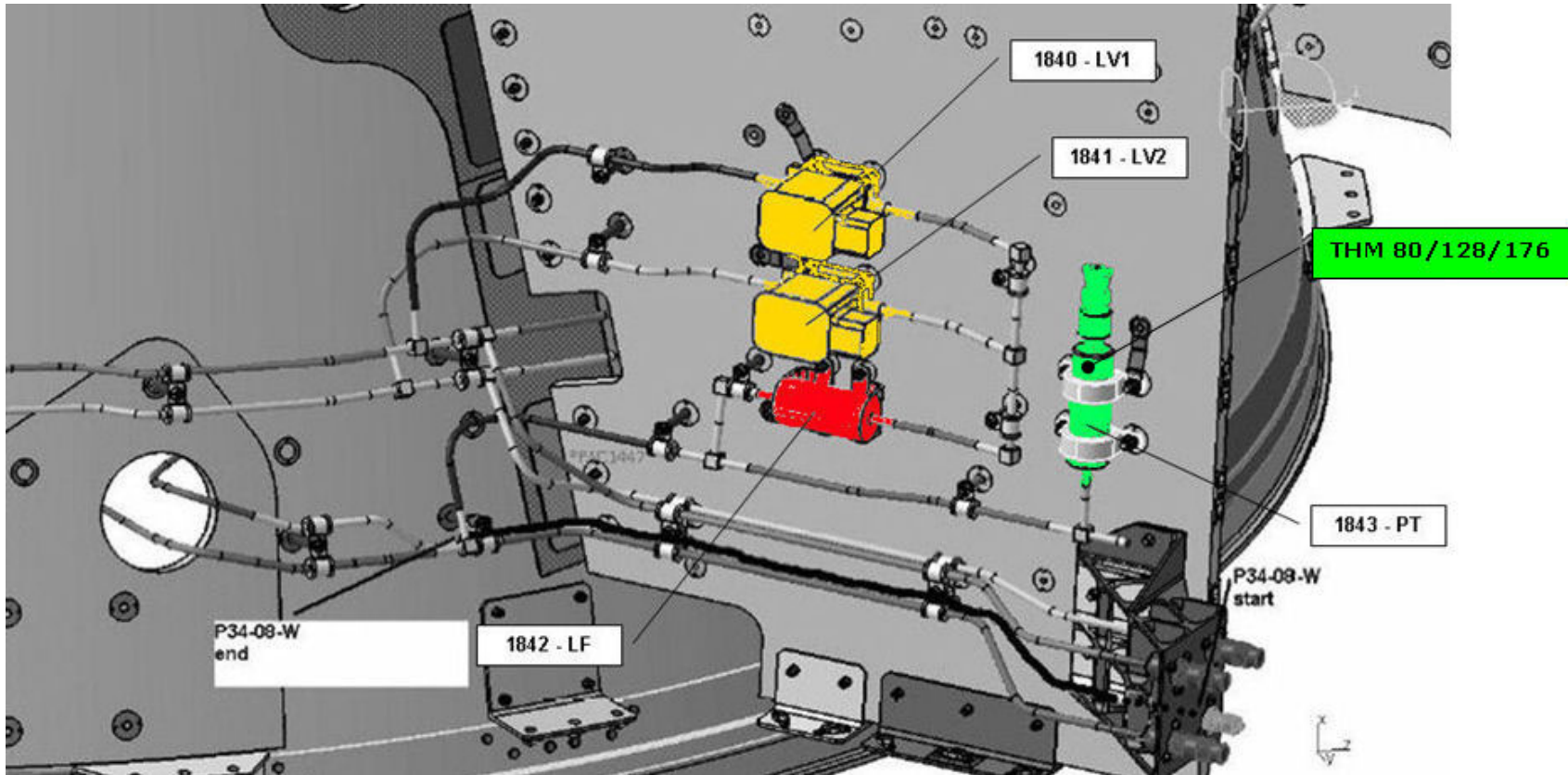

Figure 4.1.4-26 PLANCK - RCS Line #32 (RCS Units)



Controlled Distribution

4.1.5 PLANCK Power dissipations

The dissipation modes are identified in the following table respect to the status of the HFI and LFI system:

MODE	HFI	LFI
1	Prime	Prime
2	Prime	Standby
3	Standby	Prime

Table 4.1.5-1 PLANCK – Payload Units operating modes

The complete list of the power dissipation in Scientific and Telecom Mode for each case are reported in Table 4.1.6-2.

Sub-System	Switchable Unit	POWER DISSIPATION [W]					
		A1	A2	A3	B1	B2	C
		Scientific Mode	Scientific Mode	Scientific Mode	Scientific Mode	Scientific Mode	Survival
CDMS	CDMU	37.7 W	37.7 W	37.7 W	37.7 W	37.7 W	37.7 W
	ACMS						
	AAD	0.0 W	0.0 W	0.0 W	0.0 W	0.0 W	0.0 W
	ACC	32.1 W	32.1 W	32.1 W	32.1 W	32.1 W	32.1 W
	STR1	10.95 W	10.95 W	10.95 W	10.95 W	10.95 W	0.0 W
	STR2	0.0 W	0.0 W	0.0 W	0.0 W	0.0 W	0.0 W
	SAS	0.0 W	0.0 W	0.0 W	0.0 W	0.0 W	0.0 W
	SAS	0.0 W	0.0 W	0.0 W	0.0 W	0.0 W	0.0 W
	CRS1	7.1 W	7.1 W	7.1 W	7.1 W	7.1 W	7.1 W
	CRS2	7.1 W	7.1 W	7.1 W	7.1 W	7.1 W	7.1 W
	CRS3	7.1 W	7.1 W	7.1 W	7.1 W	7.1 W	7.1 W
TTC		duration = 21 hr	duration = 21 hr	duration = 21 hr	duration = 21 hr	duration = 21 hr	
	XPND1	Rx 21 W	Rx 21 W	Rx 21 W	Rx 21 W	Rx 21 W	Rx+Tx 23 W
	XPND2	Rx 10 W	Rx 10 W	Rx 10 W	Rx 10 W	Rx 10 W	Rx 10 W
	EPC1	0.0 W	0.0 W	0.0 W	0.0 W	0.0 W	9.0 W
	EPC2	0.0 W	0.0 W	0.0 W	0.0 W	0.0 W	0.0 W
	TWT1	0.0 W	0.0 W	0.0 W	0.0 W	0.0 W	32 W
	TWT2	0.0 W	0.0 W	0.0 W	0.0 W	0.0 W	0.0 W
	RFDN	0.0 W	0.0 W	0.0 W	0.0 W	0.0 W	11.8 W
	LGA1	0.0 W	0.0 W	0.0 W	0.0 W	0.0 W	Rx1+Tx2 0.0 W
	LGA2	0.0 W	0.0 W	0.0 W	0.0 W	0.0 W	Rx2+Tx1 3.0 W
	LGA3	0.0 W	0.0 W	0.0 W	0.0 W	0.0 W	Rx2+Tx1 3.0 W
MGA	0.0 W	0.0 W	0.0 W	0.0 W	0.0 W	0.0 W	
Power	PCDU	BOL 98.6 W / EOL 102.9 W	BOL 98.6 W / EOL 102.9 W	BOL 98.6 W / EOL 102.9 W	BOL 98.6 W / EOL 102.9 W	BOL 98.6 W / EOL 102.9 W	BOL 81.2 W / EOL 84.1 W
	Battery	0.0 W	0.0 W	0.0 W	2.3 W	2.3 W	0.0 W

Controlled Distribution

Sub-System	Switchable Unit	POWER DISSIPATION [W]					
		A1	A2	A3	B1	B2	C
		Scientific Mode	Scientific Mode	Scientific Mode	Scientific Mode	Scientific Mode	Survival
	THR D1A	0.71	0.71	0.71	0.71	0.71	3.55
	THR D1B	0.71	0.71	0.71	0.71	0.71	0.71
	THR D2A	0.71	0.71	0.71	0.71	0.71	3.55
	THR D2B	0.71	0.71	0.71	0.71	0.71	0.71
	THR F1A	0.71	0.71	0.71	0.71	0.71	3.55
	THR F1B	0.71	0.71	0.71	0.71	0.71	0.71
	THR F2A	0.71	0.71	0.71	0.71	0.71	3.55
	THR F2B	0.71	0.71	0.71	0.71	0.71	0.71
	THR U1A	2.84	2.84	2.84	2.84	2.84	5.68
	THR U1B	2.84	2.84	2.84	2.84	2.84	2.84
	THR U2A	2.84	2.84	2.84	2.84	2.84	5.68
	THR U2B	2.84	2.84	2.84	2.84	2.84	2.84
	THR A1A	4.56	4.56	4.56	4.56	4.56	0.0
	THR A1B	0.0	0.0	0.0	0.0	0.0	0.0
	THR B1A	4.56	4.56	4.56	4.56	4.56	0.0
	THR B1B	0.0	0.0	0.0	0.0	0.0	0.0
ESA Items	SREM	2.6 W	2.6 W	2.6 W	2.6 W	2.6 W	0.0 W
	FOG	16.5 W	16.5 W	16.5 W	16.5 W	16.5 W	0.0 W
HFI		duration = 21 hr	duration = 21 hr	duration = 21 hr	duration = 21 hr	duration = 21 hr	
	DPU N	22 W	22 W	22 W	22 W	22 W	0.0 W
	DPU R	0.0 W	0.0 W	0.0 W	0.0 W	0.0 W	0.0 W
	PAU	15 W	15 W	OFF	15 W	15 W	0.0 W
	REU	92 W	92 W	92 W	92 W	92 W	0.0 W
	4K CAU	15 W	15 W	15 W	15 W	15 W	0.0 W
	4K CEU	42.8 W	42.8 W	42.8 W	42.8 W	42.8 W	0.0 W
	4K PRU	21 W	21 W	OFF	21 W	21 W	0.0 W
	4K CCU	60 W	60 W	60 W	60 W	60 W	0.0 W
	0.1 K	16 W	16 W	16 W	16 W	16 W	0.0 W
LFI		duration = 21 hr	duration = 21 hr	duration = 21 hr	duration = 21 hr	Duration = 21 hr	
	BEU Right -	8.9 W	OFF	8.9 W	8.9 W	8.9 W	0.0 W
	BEU	9.9 W	OFF	9.9 W	9.9 W	9.9 W	0.0 W
	BEU Left	9.9 W	OFF	9.9 W	9.9 W	9.9 W	0.0 W
	DAE	16.9 W	OFF	16.9 W	16.9 W	16.9 W	0.0 W
	REBA N	22.7 W	22.7 W	22.7 W	22.7 W	22.7 W	0.0 W
	REBA R	0.0 W	0.0 W	0.0 W	0.0 W	0.0 W	0.0 W
SCS		duration = 21 hr	Duration = 21 hr	duration = 21 hr	duration = 21 hr	Duration = 21 hr	
	SCC N	See para 8.5.1	See para 8.5.1	See para 8.5.1	See para 8.5.1	0.0 W	0.0 W
	SCC R	0.0 W	0.0 W	0.0 W	0.0 W	See para 8.5.1	0.0 W
	SCE N	60 W	60 W	60 W	110 W	0.0 W	0.0 W
	SCE R	0.0 W	0.0 W	0.0 W	0.0 W	110 W	0.0 W

Table 4.1.5-2 PLANCK – Scientific Mode Power dissipations

Controlled Distribution



REFERENCE : H-P-RP-AI-0040

DATE : 29/SEP/06

ISSUE : 06

Page : 110/405

Sub-System	Switchable Unit	POWER DISSIPATION [W]				
		A1	A2	A3	B1	B2
		Telecom	Telecom	Telecom	Telecom	Telecom
CDMS						
	CDMU	37.7 W	37.7 W	37.7 W	37.7 W	37.7 W
ACMS	AAD	0.0 W	0.0 W	0.0 W	0.0 W	0.0 W
	ACC	32.1 W	32.1 W	32.1 W	32.1 W	32.1 W
	STR1	10.95 W	10.95 W	10.95 W	10.95 W	10.95 W
	STR2	0.0 W	0.0 W	0.0 W	0.0 W	0.0 W
	SAS	0.0 W	0.0 W	0.0 W	0.0 W	0.0 W
	SAS	0.0 W	0.0 W	0.0 W	0.0 W	0.0 W
	CRS1	7.1 W	7.1 W	7.1 W	7.1 W	7.1 W
	CRS2	7.1 W	7.1 W	7.1 W	7.1 W	7.1 W
	CRS3	7.1 W	7.1 W	7.1 W	7.1 W	7.1 W
TTC		duration = 3 hr	duration = 3 hr	duration = 3 hr	duration = 3 hr	duration = 3 hr
	XPND1	Rx+Tx 23 W	Rx+Tx 23 W	Rx+Tx 23 W	Rx+Tx 23 W	Rx+Tx 23 W
	XPND2	Rx 10 W	Rx 10 W	Rx 10 W	Rx 10 W	Rx 10 W
	EPC1	9.0 W	9.0 W	9.0 W	9.0 W	9.0 W
	EPC2	0.0 W	0.0 W	0.0 W	0.0 W	0.0 W
	TWT1	32 W	32 W	32 W	32 W	32 W
	TWT2	0.0 W	0.0 W	0.0 W	0.0 W	0.0 W
	RFDN	11.8 W	11.8 W	11.8 W	11.8 W	11.8 W
	LGA1	0.0 W	0.0 W	0.0 W	0.0 W	0.0 W
	LGA2	0.0 W	0.0 W	0.0 W	0.0 W	0.0 W
	LGA3	0.0 W	0.0 W	0.0 W	0.0 W	0.0 W
	MGA	Rx1+Tx1 3.0 W	Rx1+Tx1 3.0 W	Rx1+Tx1 3.0 W	Rx1+Tx1 3.0 W	Rx1+Tx1 3.0 W
Power						
	PCDU	BOL 99.3 W / EOL 102.9 W	BOL 99.3 W / EOL 102.9 W	BOL 99.3 W / EOL 102.9 W	BOL 99.3 W / EOL 102.9 W	BOL 99.3 W / EOL 102.9 W
	Battery	0.0 W	0.0 W	0.0 W	2.3 W	2.3 W
Thruster						
	THR D1A	0.71	0.71	0.71	0.71	0.71
	THR D1B	0.71	0.71	0.71	0.71	0.71
	THR D2A	0.71	0.71	0.71	0.71	0.71
	THR D2B	0.71	0.71	0.71	0.71	0.71
	THR F1A	0.71	0.71	0.71	0.71	0.71
	THR F1B	0.71	0.71	0.71	0.71	0.71
	THR F2A	0.71	0.71	0.71	0.71	0.71
	THR F2B	0.71	0.71	0.71	0.71	0.71
	THR U1A	2.84	2.84	2.84	2.84	2.84
	THR U1B	2.84	2.84	2.84	2.84	2.84
	THR U2A	2.84	2.84	2.84	2.84	2.84
THR U2B	2.84	2.84	2.84	2.84	2.84	



Controlled Distribution

Sub-System	Switchable Unit	POWER DISSIPATION [W]				
		A1	A2	A3	B1	B2
		Telecom	Telecom	Telecom	Telecom	Telecom
	THR A1A	4.56	4.56	4.56	4.56	4.56
	THR A1B	0.0	0.0	0.0	0.0	0.0
	THR B1A	4.56	4.56	4.56	4.56	4.56
	THR B1B	0.0	0.0	0.0	0.0	0.0
ESA Items	SREM	2.6 W	2.6 W	2.6 W	2.6 W	2.6 W
	FOG	16.5 W	16.5 W	16.5 W	16.5 W	16.5 W
HFI		duration = 3 hr	duration = 3 hr	duration = 3 hr	duration = 3 hr	duration = 3 hr
	DPU N	22 W	22 W	22 W	22 W	22 W
	DPU R	0.0 W	0.0 W	0.0 W	0.0 W	0.0 W
	PAU	15 W	15 W	OFF	15 W	15 W
	REU	92 W	92 W	92 W	92 W	92 W
	4K CAU	15 W	15 W	15 W	15 W	15 W
	4K CEU (4KCDE)	42.8 W	42.8 W	42.8 W	42.8 W	42.8 W
	4K PRU (4KCCR)	21 W	21 W	OFF	21 W	21 W
	4K CCU	60 W	60 W	60 W	60 W	60 W
	0.1 K DCCU	16 W	16 W	16 W	16 W	16 W
LFI		duration = 3 hr	duration = 3 hr	duration = 3 hr	duration = 3 hr	duration = 3 hr
	BEU Right - Y	8.9 W	OFF	8.9 W	8.9 W	8.9 W
	BEU Central	9.9 W	OFF	9.9 W	9.9 W	9.9 W
	BEU Left +Y	9.9 W	OFF	9.9 W	9.9 W	9.9 W
	DAE	16.9 W	OFF	16.9 W	16.9 W	16.9 W
	REBA N	22.7 W	22.7 W	22.7 W	22.7 W	22.7 W
REBA R	0.0 W	0.0 W	0.0 W	0.0 W	0.0 W	
SCS		duration = 3 hr	duration = 3 hr	duration = 3 hr	duration = 3 hr	duration = 3 hr
	SCC N	See para 8.5.1	See para 8.5.1	See para 8.5.1	See para 8.5.1	0.0 W
	SCC R	0.0 W	0.0 W	0.0 W	0.0 W	See para 8.5.1
	SCE N	60 W	60 W	60 W	110 W	0.0 W
SCE R	0.0 W	0.0 W	0.0 W	0.0 W	110 W	

Table 4.1.5-3 PLANCK – Telecom Mode Power dissipations

Controlled Distribution



REFERENCE : H-P-RP-AI-0040

DATE : 29/SEP/06

ISSUE : 06

Page : 112/405

4.1.6 PLANCK Units Conductors

In the following table a list of typical Units data, including the Units – Panel contact conductance, is presented. The highlighted values have been modified as a consequence of the PFM#1 test, in the frame of the correlation activities (see AD39).

DCCU units-panel conductance has been re-assessed on the basis of new input data provided by AAS-F (the unit was considered not representative in PFM#1 test) and a description of the DCCU configuration is provided in Para. 4.1.8.

Further details about unit-panel contact conductance calculation are given in Para. 5.2.

UNIT	NODE	PANEL	CAPACITY [J/K]	CONTACT AREA [CM ²]	CONTACT TYPE	GL [W/K]
SREM	3966	EXTERNAL +Y+Z	2160	295	Metal-Metal	0.7
SAS-X	3951	EXTERNAL -X	130	7.44	Metal-Metal	0.744 with bracket (AD14)
AAD	3970	EXTERNAL -X	76.2	5.2	Metal-Metal	0.524 with bracket (AD15)
MGA-X	3986	EXTERNAL -X	69.2		Washer	0.0510 (AD17)
LGA-X	3991	EXTERNAL -X	110		Washer	0.0510 (AD16)
LGA-Y	3961	EXTERNAL -Y	110		Washer	0.0667 (AD16)
LGA+Y	3921	EXTERNAL +Y	110		Washer	0.0667 (AD16)
SAS+Y	3931	EXTERNAL +Y	130	7.44	Metal-Metal	1.335 with bracket (AD14)
RFDN	605	-Y	5150	350	Filler	2.32
EPC1	606	-Y	1230	118.5	Filler	3.62
EPC2	607	-Y	1230	118.5	Filler	3.72
TRANSX1	601	-Y	3688	109.2	Filler	5.84
TRANSX2	602	-Y	3688	109.2	Filler	5.84
TWTA1	603	-Y	448	136	Filler	5.77
TWTA2	604	-Y	448	136	Filler	5.77
CRS1	705	SHEAR -Y+Z	1523	29.6(*)	Filler	0.58
CRS2	706	SHEAR -Y+Z	1523	29.6(*)	Filler	1.16
CRS3	551	SHEAR -Y-Z	1523	29.6(*)	Filler	1.16
PCDU	704	-Y+Z	23490	1802	Filler	17.65
CDMU	701	-Y+Z	14004	551	Filler	11.33
ACC	702	-Y+Z	12400	513	Filler	15.6
BATT	703	-Y+Z	5463	19.6(*)	Filler	0.758
DPU1	13	+Z	5520	813	Filler	9.34
DPU2	14	+Z	5520	813	Filler	9.34
DCCU	101	+Y+Z	20000	5280	Bolts Filler	5.42 unit with HC baseplate 52.8 HC basepl with panel
REBA1	103	+Y+Z	4200	510	Filler	8.5
REBA2	102	+Y+Z	4200	510	Filler	8.5
FOG (GEU)	104	SHEAR +Y+Z	3360	358	Filler	6.55
FOG (ICU)	105	SHEAR +Y+Z	1920	6 bolts	Metal-Metal	0.06



Controlled Distribution



REFERENCE : H-P-RP-AI-0040

DATE : 29/SEP/06

ISSUE : 06

Page : 113/405

UNIT	NODE	PANEL	CAPACITY [J/K]	CONTACT AREA [CM ²]	CONTACT TYPE	GL [W/K]
4K CAU	202	+Y	5680	1225	Filler	12.14
4K PRE REG	203	+Y	2200	400	Filler	6.87
CEU	204	+Y	4550	402	Filler	8.52
REU	205	+Y	26800	1460	Filler	13.94
4K CCU	219, 220, 221, 222	+Y	15870	98	Filler	1.3 for each bracket 6.92 for each strap
SCC1	311-336	+Y-Z	Array value		On Heat Pipe	38.1 each bed
SCE1	401	-Z	6800		On Heat Pipe	33.75
SCE2	402	-Z	6800		On Heat Pipe	33.75
SCC2	511-536	-Y-Z	Array value		On Heat Pipe	38.1 each bed
BEU	519	EXTERNAL SUBPLATFORM	6704	500	Filler	4.28 with panel
BEU	520	EXTERNAL SUBPLATFORM	7656	720	Filler + Doubler	9.76 with doubler
BEU	521	EXTERNAL SUBPLATFORM	6704	500	Filler	3.09 with panel
PAU	522	EXTERNAL SUBPLATFORM	8000	1055	Filler	10.55 with doubler
DAE	525	EXTERNAL SUBPLATFORM	5032	400	Filler	1.95
1N Thr A1	8561	EXTERNAL -Y+Z	92.1		Filler	0.2
1N Thr B1	8761	EXTERNAL -Y+Z	92.1		Filler	0.2
THR D1	1132	+Z	92.1		Filler	1.6
THR D2	1232	+Y+Z	92.1		Filler	1.6
THR F1	1332	+Y-Z	92.1		Filler	1.6
THR F2	1432	-Z	92.1		Filler	1.6
THR U1	1532	-Y-Z	92.1		Filler	1.6
THR U2	1732	-Y+Z	92.1		Filler	1.6
STR1	5401-5486	+Z			Metal-Metal	5.04 (AD26)
STR2	5501-5586	+Z			Metal-Metal	5.04 (AD26)

Table 4.1.6-1 PLANCK – Units-Panels conductors



Controlled Distribution

4.1.7 PLANCK SVM-Payload I/F points

The interface nodes are:

I/F NODES	I/F TYPE
10001-10004-10005	Groove Shield
10010-10011-10012	Mechanical struts
10021 ÷ 10026	PLM I/F nodes

Table 4.1.3-1 PLANCK – SVM-Payload I/F points

In the following figure the attachment points with the PLM are shown.

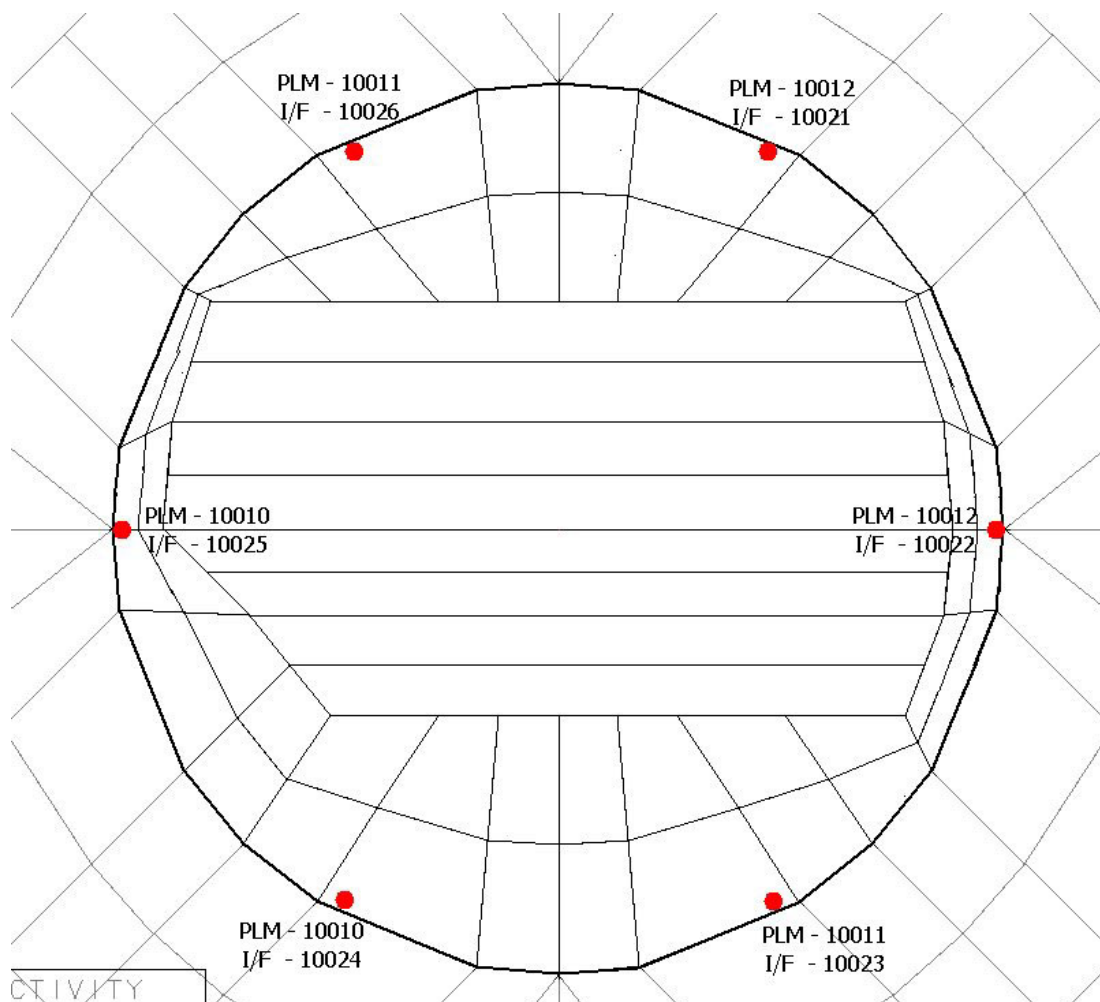

Figure 4.1.7-1 PLANCK - PLM I/F attachment points

4.1.8 DCCU configuration

The DCCU configuration has been re-assessed on the basis of the following input data:

- Baseplate honeycomb:
 - total mass (including the two face sheets) of 5,6 kg
 - overall dimensions are 30x800x600 mm
 - honeycomb aluminium type 5056, thickness 30 mm
 - facesheets thickness is 0.8 mm on both sides (aluminium type 2024 T3)
- DCE
 - mounted on the baseplate with no filler and fixed with only 4 screws,
 - contact area of 224x224 mm²

The GL have been assessed considering a low interface conductance between DCE and the baseplate HC (100W-m²K); the coupling between honeycomb and the SVM panel has been considered unchanged.

Following the PFM#1 test data, it has been put in evidence a critical situation occurring for the DCCU in Survival mode, with no heater installed on the unit, the temperature reached by DCCU is about -24° (uncertainty included) versus a non operative limit of -20°.

It has been identified an available area, on the honeycomb baseplate, where an additional heater should be installed as reported in the following figure:

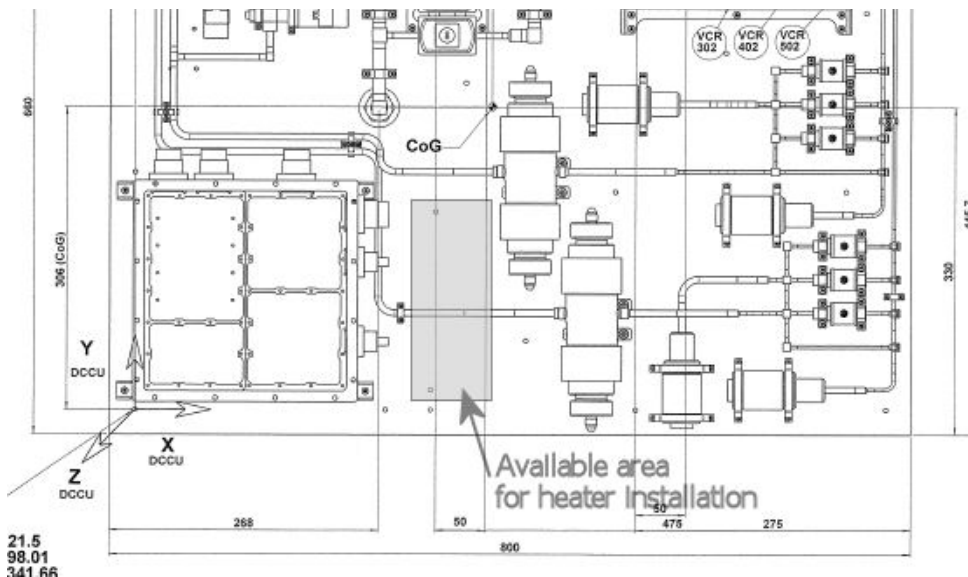

Figure 4.1.8-1 DCE possible heater location.

The heater could be added to the existent heater line #36, that supply REBA heaters always mounted on the +Y+Z panel, and in order to recover the Survival low temperature the heater has been identified as a Type "G", 140X40 mm, 64 Ohm, 11.39W.

The analysis results show that in this configuration the DCCU (DCE box) is maintained in survival case at a temperature of -12.7°C

5 HERSCHEL & PLANCK CONDUCTIVE COUPLINGS

5.1 MLI conductivity

A temperature-variable conductive coupling (non linear) array simulates the MLI blanket behaviour. The different arrays used in the TMM, applicable to different MLI compositions, are given in the following Table. They are part of Alenia Spazio heritage. They are calculated with a semi-empirical curve derived from test data on Spacelab program [RD-2.2] and extensively used on several programs (Italsat, Artemis, Integral, MPLM, Atlantic Bird-1, Columbus, Nodes). The used semi-empirical correlation was substantially confirmed through the Thermal Balance Tests performed on the above programs and by a dedicated test on a MPLM MLI sample. By the way, Alenia used formula is in good agreement with the empirical correlation proposed in the [RD-2.3]. Application is:

HERSCHEL

- 20 layers MLI composition is used on the Top of the Satellite facing to HPLM
- 10 layers MLI composition (Type A) is used on lower panel (-X side)
- 10 layers MLI composition (Type B) is used in general on all the external surfaces
- 7 layers MLI composition is used on HIFI units, internal -Y -Z Panel, Internal -Y Panel, STR secondary baffle, STR unit, STR radiator and on the Tanks
- On the STR struts the MLI efficiency has been improved of 90% after correlation

PLANCK

- 20 layers MLI composition is used on the Top of the Satellite facing to PPLM and on Solar Arrays
- 10 layers MLI composition (Type B) is used on all other external surfaces and over Wave Guide, SAS, LGA, SREM
- 7 layers MLI composition is used on the Tanks and on the SCC panels

Temperature [°C]	MLI CONDUCTIVITY [W/m ² /°C]			
	20 Layers	10 Layers Type A	10 Layers Type B	7 Layers
-100	0.0175	0.0233	0.03495	0.0314
-90	0.0212	0.0275	0.04125	0.0362
-80	0.0251	0.0320	0.0480	0.0413
-70	0.0292	0.0366	0.0549	0.0468
-60	0.0334	0.0416	0.0624	0.0527
-50	0.0378	0.0469	0.0703	0.0590
-40	0.0424	0.0524	0.0785	0.0659
-30	0.0473	0.0584	0.0785	0.0733
-20	0.0523	0.0647	0.0785	0.0812
-10	0.0577	0.0714	0.0785	0.0898
0	0.0633	0.0785	0.0785	0.0990
10	0.0692	0.0861	0.0861	0.1088
25	0.0786	0.0984	0.0984	0.1250
30	0.0819	0.1027	0.1027	0.1308
40	0.0888	0.1118	0.1118	0.1430
50	0.0960	0.1214	0.1214	0.1560

Temperature [°C]	MLI CONDUCTIVITY [W/m ² /°C]			
	20 Layers	10 Layers Type A	10 Layers Type B	7 Layers
60	0.1036	0.1317	0.1317	0.1699
70	0.1116	0.1425	0.1425	0.1848
80	0.1200	0.1540	0.1540	0.2006
90	0.1288	0.1661	0.1661	0.2174
100	0.1381	0.1789	0.1789	0.2352

Table 5-1 - MLI Thermal Conductivity for different number of layers

5.2 Unit-Panel Conductivity

Calculation of linear conductors between units and panel is performed considering in general two contributions: the conduction due to the contact area, and the spreading effect; the last one is present when the mounting node area is bigger than contact area.

The linear conductor due to the contact area is evaluated by means of the formula:

$$GL = G_c * A_c \quad [W/°C] \quad (1)$$

Where:

With filler

- for contact area between 30 and 1000 cm² :

$$G_c = 50000 * C_c^{-0.9} \quad (C_c = \text{contact area in cm}^2)$$

$$A_c = \text{contact area in m}^2$$

- for contact area bigger than 1000 cm² :

$$G_c = 100$$

$$A_c = \text{contact area in m}^2$$

Without filler

for contact area between 30 and 500 cm² we have

$$G_c = 50 * \frac{800 - C_c}{150 + C_c} \quad (C_c = \text{contact area in cm}^2) \quad (2)$$

$$A_c = \text{contact area in m}^2$$

The above formulas are based on data from dedicated test performed on Olympus program (1988) and successfully used in the Alenia programs since then. Thermal Balance Test correlations of Italsat-1/2, SAX, TSS-1/2, Artemis, Integral, Atlantic Bird-1, confirmed the applicability of the used formulas.

Regards the spreading effect, the Thermal Balance Test correlations on previous programs have shown that the spreading calculation is necessary when the contact area is smaller than about 45 % of mounting node area.

Controlled Distribution

The spreading effect is represented by an equivalent linear conductor (G_{spread}) that should be put in series with the linear conductor (GL) evaluated by means of the previous formulas.

For units with a small contact area by means of feet, the linear conductor for each foot will be calculated multiplying the contact area in m^2 for a contact constant, considering filler, of $2000 W/m^2/K$. Of course the eventual spreading effect will be put in series if necessary.

When the contact area of an unit covers more than one mounting node, the spreading effect is evaluated considering the contribution of each portion of contact area on relevant mounting node (see example in Figure 5.2-1: the portion of contact area on the node number 4 is highlighted in gray).

For each mounting node the linear conductor will be calculated as series of the following conductors:

1. The linear conductor (GL) obtained proportionally at the contact area projected on the mounting node of the total linear conductor calculated by the formula (1)
2. The relevant spreading effect (G_{spread}).

In the example of figure below, the spreading effect will be present in the mounting nodes 1,4,13 and 16 (portion of contact area less than 45% of node area) and will not be present in the mounting nodes 6,7,10 and 11. For the other nodes if the percentage of area of mounting node covered from the unit will be lower than 45% the spreading effect will be calculated otherwise no spreading effect will be present

Figure 5.2-1 Unit-Panel contact areas

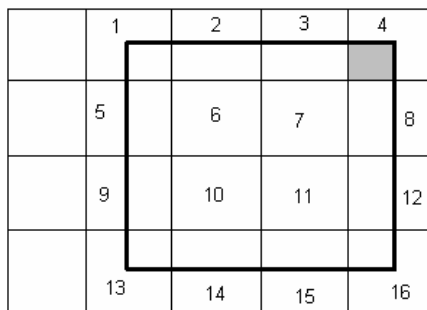

Details of Unit-Panel contact conductances (including spreading effect if applicable) are given in Table 3.2.2-1 for HERSCHEL and Table 3.2.2-2 for PLANCK; modified values are highlighted.

5.3 Honeycomb Panel Conductivity

- Conductive couplings across honeycomb panel (identified as “Z” direction) are calculated by multiplying the effective thermal conductivity K_z and the cross section between two thermal nodes (panel internal / external sides):

$$GL(int,ext) = K_z * A(node) / d$$

where

K_z = thermal conductivity across the honeycomb [$W/m^{\circ}C$]

$A(node)$ = node area [m^2]

d = overall thickness of the honeycomb panel [m]

Controlled Distribution

- Lateral thermal conductance of honeycomb panel (identified as “XY” direction) is calculated by multiplying the effective thermal conductivity K_{xy} by the cross section and dividing it by the distance between the two thermal nodes.

$$GL(xxx,yyy) = K_{xy} * A(\text{cross section}) / d$$

where

K_{xy} = in plane conductivity of the honeycomb

A(cross section) = cross section between the two nodes

d = distance of the center of mass of the two adjacent nodes

Structural characteristics and thermal conductivity (K_{xy} and K_z) of the panels are reported in table 5.3-1 for HERSCHEL and 5.3-2 for PLANCK (note: the conductivity evaluation has been made as per [RD2-1]).

LOCATION	H/C TYPE	SKIN TYPE	SKIN Conducib. [W/mK]	SKIN THICK. [mm]	CORE THICK. [mm]	K_{xy} [W/mK]	K_z [W/mK]
Upper and Lower Closure	3/16-5056-.0007	M18/G801	20	0.4	20	1.21	1.19
Lateral	3/16-5056-.0007	AA7075T6	130	0.3	35	2.64	1.17*1.4 = 1.64
Top Platform central disc	3/16-5056-.0007	M18/G801	20	0.3	20	1.03	1.18
Shear Web	3/16-5056-.001	M18/G969	20	0.76	15	2.43	1.78
Cone	3/16-5056-.001	M40/914	20	0.54	15	1.95	1.74
Reinforced Cone	1/8-5056-.002	M40/914	20	1.08	13.92	4.39	5.32
STR baseplate +X	3/16-5056-.0007	HCF(*)	350 eq	2	55	24.15	1.25
STR baseplate -X	3/16-5056-.0007	HCF(*)	350 eq	3	55	34.84	1.25

(*) High conductivity Carbon Fiber.

Table 5.3-1 HERSCHEL – SVM Honeycomb panels & structural parts thermal properties

LOCATION	H/C TYPE	SKIN TYPE	SKIN Conducib. [W/mK]	SKIN THICK. [mm]	CORE THICK. [mm]	K_{xy} [W/mK]	K_z [W/mK]
Top & Bottom Floor	3/16-5056-.0007	M18/G801	20	0.4	20	1.21	1.19
Radiator Panels	3/16-5056-.0007	AA7075T6	130	0.3	35	2.64	1.17*1.4 = 1.64
SCC Panels	3/16-5056-.0007	AA7075T6	130	0.3	35	2.64	1.17
Radiator Panel +Y	3/16-5056-.0007	AA7075T6	130	0.6	35	4.75	1.19
Payload Subplatform	3/16-5056-.0007	AA7075T6	130	0.3	19.4	4.34	1.18
Shear Web	3/16-5056-.0007	M18/G969	20	0.76	15	2.25	1.26
Cone	3/16-5056-.001	M40/914	20	0.54	15	1.95	1.74
Reinforced Cone	1/8-5056-.002	M40/914	20	1.08	13.92	4.39	5.32
Solar Array	Al	M55	20	0.18	20	0.825	1.31

Table 5.3-2 PLANCK – SVM Honeycomb panels thermal properties

Struts to CVV are made in glass fiber with titanium blade, the K is variable as in the following table:

GLASS FIBER CONDUCTIVITY	
T [°C]	K [W/mK]
-150	0.38
-140	0.40
-110	0.44
-90	0.48
-70	0.55
-50	0.64
-30	0.75

Table 5.3-3 HERSCHEL – SVM struts conductivity

5.4 Doubler – panel conductivity

The linear conductor between doubler and panels has been calculated by means the $3000 \cdot A_c$. In the linear conductor computation the spreading effect has not been considered because the doubler nodes have the same sizing of the undelying panel nodes.

5.5 Cleats linear conductivity

The linear couplings between panels and between panels and platforms have been calculated between the two elements (1 and 2 in Figure 5.5-1) as a serie of three linear thermal conductors:

- GL of half part of the element 1 = $K \cdot A / d$
- GL of the link cleat or insert
- GL of half part of element 2 = $K \cdot A / d$

The contact conductance and the screw conductance are added and put in serie with the cleat material conductance to evaluate the global linear conductance GL due to the link.

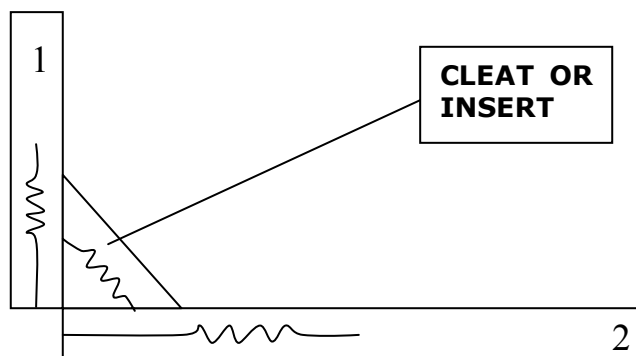

Figure 5.5-1 Cleats conductors

Controlled Distribution

The GL has been calculated studying the different geometry and the different type of contact for each cleat or insert; the drawings are given in [AD3]. In Table 5.5-1 a list of GL for different cleats/insert geometries is given:

LINKED PANELS	TYPE OF LINK	GL [W/K]
HERSCHEL		
Lateral panel-lateral panel	CLEAT1	0.39
Lateral panel-lateral panel -Y and -Y-Z	WCLEAT1	0.08
Lateral panel-top floor and lateral panel-bottom floor	INSERT	0.21
Lateral panel-top floor and lateral panel-bottom floor -Y and -Y-Z	WINSERT	0.1
Shear web-top floor and shear web-bottom floor	INSERT1	0.32
Shear web-lateral panel	INSERT2	0.33
Shear web-lateral panel -Y	WINSERT2	0.09
Shear web-cone	CLEAT2	0.43
Cone-bottom floor	CLEAT3SCREW	0.36
Cone-bottom floor -Y and -Y-Z	CLEAT4SCREW	0.48
Adaptor ring-bottom closure panel	CLEAT_ADAPT_RCS	0.43
PLANCK		
SCC panel - Top, Bottom and Shear Web	KINSERT3	0.0185
SCC panel - other Lateral Panels	CLEAT3	0.031

Table 5.5-1 Cleats and inserts linear conductors

5.6 PLANCK Heat Pipes conductivity

The heat pipes network has been performed as reported in [AD8] with the following updating coming from the CDR discussion:

- **Correction of thermal capacity**
RID CDR-TCS-ASP-ENG-067

ALS has again calculated, using the data from the EHP MRR DP, the updated value for the thermal capacity. The new data are:

Horizontal H.P. 400 J/K*m	was 800 J/K*m
Vertical H.P. 360 J/K*m	was 420 J/K*m

- **Correct GL HP vertical I/F – HP vertical evaporator**
RID CDR-TCS-ASP-ENG-064

ALS update the GL between HP vert.I/F(nodes 811-825, 861-875) and HP vert. Evaporator (nodes 8011-8025, 8061-8075) considering a contact area for each conductor of $(0.0508 + \text{spreading } 45^\circ) * 0.025 = 1.645e-03 \text{ m}^2$. Previous value was computed considering a contact area for each conductor of $(0.78 * 0.025) = 19.5e-03 \text{ m}^2$.

- **Consider GL HP vertical I/F at the extremity**
RID CDR-TCS-ASP-ENG-109

ALS update the TMM considering the GL between the HP vert. I/F at the extremity (nodes 811,826,861,876) and the SCC Outer Shell (nodes 311-316, 511-516) reduced by half due to the reduced contact area of the HP located at the extremity.

- **Heat pipes conductive couplings**
RID CDR-TCS-ASP-ENG-121

The conductors between HP hor (nodes 801-808, 851-858) and SCC radiators have been updated considering the dimension taken from the EHP drawings issued on 1st March 2004. The values are:

Nodes 801-808 to SCC panel +Y-Z :	$G_c = 50000 * A_c^{-0.9} = 222 \text{ W/m}^2$	was 213.27 W/m ²
Nodes 801-808 to SCC panel -Z :	$G_c = 50000 * A_c^{-0.9} = 304.88 \text{ W/m}^2$	was 324.14 W/m ²
Nodes 851-858 to SCC panel -Y-Z :	$G_c = 50000 * A_c^{-0.9} = 220.7 \text{ W/m}^2$	was 213.27 W/m ²

5.7 PLANCK Solar Array conductivity

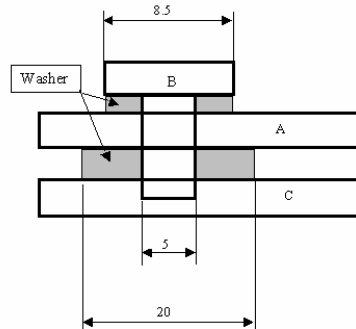

Figure 5.7-1 PLANCK – Connection via screw

External Solar Array

Each external solar array panel has two kinds of connections:

1. External solar array panel with Lower Closure Panel
2. External solar array panel with Lateral Panel by means a bracket

1) External solar array panel with Lower Closure Panel

For each first kind connection is used (12 points in total):

- One thermal washer in vetronite (thickness 1 mm) under the screw head;
- One thermal washer in vetronite (thickness 19 mm) in the I/F between Solar array panel and lower closure panel

On the basis of figure 3.2.7-1 we have:

- between A and B a vetronite washer of 1 mm
- between A and C a vetronite washer of 19 mm
- K screw : 15 W/m °C; K washer: 0.288 W/m² °C
- thickness A (solar array) 25 mm

GL A-B = 0.0107 W/°C

GL B-C (by screw) = 0.0065 W/°C

Therefore the GL A-C, between the parts A and C (by screw), is the series of GL A-B and GL B-C.

GL A-C (by screw) = 0.0041 W/°C

GL A-C (by washer) = 0.0045 W/°C

GL A-C (total) = **0.0085 W/°C** for each screw.

2) External solar array panel with Lateral Panel by means a bracket

For each second kind connection is used (16 points in total):

- One thermal washer in vetronite (thickness 1 mm) under the each screw head;
- One thermal washer in vetronite (thickness 5 mm) for each screw, in the I/F between external Solar Array panel and Solar Array lateral bracket.
- One thermal washer in vetronite (thickness 3 mm) for each screw between Solar Array lateral bracket and lateral panel

For each point the Solar array is connected to panels by means a bracket in titanium fixed to solar array with 4 titanium screws M5 (GL1) and to panels with 4 titanium screws M5 (GL2).

~~Considering the linear conductor of the bracket as GL3, the total linear conductor between solar array and panel is the series of GL1, GL2 and GL3.~~

On the basis of figure 3.2.7-1 we have:

~~GL1 (external solar array with bracket):~~

- ~~• between A and B a vetronite washer of 1 mm~~
- ~~• between A and C a vetronite washer of 5 mm~~
- ~~• K screw : 15 W/m °C; K washer: 0.288 W/m2 °C~~
- ~~• thickness A (bracket) 3 mm~~

~~GL A-B = 0.0107 W/°C~~

~~GL B-C (by screw) = 0.0327 W/°C~~

~~Therefore the GL A-C, between the parts A and C (by screw), is the series of GL A-B and GL B-C.~~

~~GL A-C (by screw) = 0.0081 W/°C~~

~~GL A-C (by washer) = 0.0170 W/°C~~

~~GL1 = GL A-C (total) = 0.0250 W/°C. Considering 4 screws = 0.1 W/°C~~

~~GL2 (by bracket):~~

- ~~• In titanium (K=15 W/m °C)~~
- ~~• width: 90 mm~~
- ~~• thickness: 3 mm~~
- ~~• Length: 300 mm~~

~~GL2 = 0.0135 W/°C~~

~~GL3 (panel and bracket)~~

- ~~• between A and B a vetronite washer of 1 mm~~
- ~~• between A and C a vetronite washer of 3 mm~~
- ~~• K screw: 15 W/m °C; K washer: 0.288 W/m2 °C~~
- ~~• thickness A (bracket) 3 mm~~

~~GL A-B = 0.0107 W/°C~~

~~GL B-C (by screw) = 0.0421 W/°C~~

~~Therefore the GL A-C, between the parts A and C (by screw), is the series of GL A-B and GL B-C.~~



Controlled Distribution

GL A C (by screw) = 0.0085 W/°C

GL A C (by washer) = 0.0283 W/°C

GL3 = GL A C (total) = 0.0368 W/°C. Considering 3 screws = 0.1104 W/°C

The total GL as series of GL1, GL2 and GL3 = **0.0107 W/°C**

After the correlation activity related to the PFM#1 test, the thermal network between Lateral Panels and the External Disc Solar Array has been changed introducing the Solar Array brackets, and MLI blanket on them, as diffusive nodes, and the linear conductors modified to the following values:

GL (Bracket, Lateral Panel) = 0.147 W/K

GL (Bracket, Ext. Solar Array) = 0.0266 W/K

A sketch of the connections is reported below.

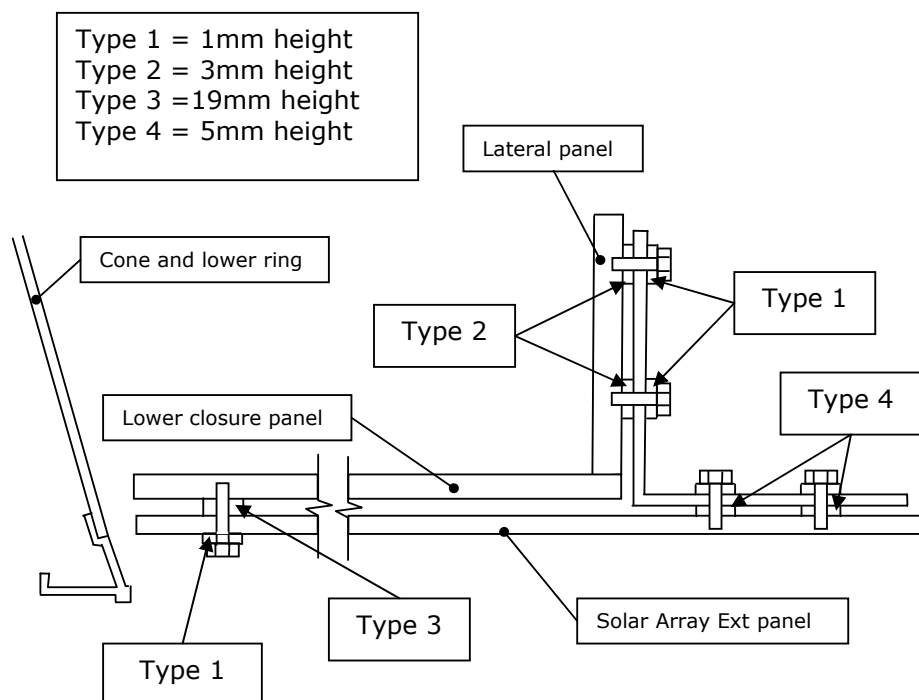

Figure 5.7-2 PLANCK – Connection Solar Array-Lateral panel

Central Solar Array

The central Solar array is connected by means 12 aluminum brackets to internal cone.
I/F between bracket and solar array is performed by means a titanium screw M5 with a vetronite washer of 2 mm under the head screw and a vetronite washer of 5 mm between solar array and bracket.
I/F between bracket and cone is performed by means 4 steel screws ($K=36 \text{ W/m}^{\circ}\text{C}$). Each screw has a vetronite washer of 3 mm between bracket and cone. The total linear conductor is obtained as series of linear conductors of the bracket and of the two connections: solar array side and cone side.

On the basis of figure 3.2.7-1 we have:

GL1 (between bracket and cone):

- between A and B no washer (assumed a contact conductivity of $1000 \text{ W/m}^2 \text{ }^{\circ}\text{C}$)
- between A and C a vetronite washer of 3 mm
- K screw : $36 \text{ W/m}^{\circ}\text{C}$; K washer: $0.288 \text{ W/m}^2 \text{ }^{\circ}\text{C}$
- thickness A (bracket) 3 mm

$$\text{GL A-B} = 0.0371 \text{ W}^{\circ}\text{C}$$

$$\text{GL B-C (by screw)} = 0.1178 \text{ W}^{\circ}\text{C}$$

Therefore the GL A-C, between the parts A and C (by screw), is the series of GL A-B and GL B-C.

$$\text{GL A-C (by screw)} = 0.0282 \text{ W}^{\circ}\text{C}$$

$$\text{GL A-C (by washer)} = 0.0283 \text{ W}^{\circ}\text{C}$$

$$\text{GL1} = \text{GL A-C (total)} = 0.0565 \text{ W}^{\circ}\text{C}. \text{ Considering 4 screws} = 0.226 \text{ W}^{\circ}\text{C}$$

GL2 (by bracket):

- In aluminum ($K=150 \text{ W/m}^{\circ}\text{C}$)
- width: 115 mm
- thickness: 3 mm
- Length: 100 mm

$$\text{GL2} = 0.518 \text{ W}^{\circ}\text{C}$$

GL3 (solar array and bracket)

- between A and B a vetronite washer of 2 mm
- between A and C a vetronite washer of 5 mm
- K screw: $15 \text{ W/m}^{\circ}\text{C}$; K washer: $0.288 \text{ W/m}^2 \text{ }^{\circ}\text{C}$
- thickness A (bracket) 3 mm

$$\text{GL A-B} = 0.0053 \text{ W}^{\circ}\text{C}$$

$$\text{GL B-C (by screw)} = 0.0295 \text{ W}^{\circ}\text{C}$$

Therefore the GL A-C, between the parts A and C (by screw), is the series of GL A-B and GL B-C.

$$\text{GL A-C (by screw)} = 0.0045 \text{ W}^{\circ}\text{C}$$

$$\text{GL A-C (by washer)} = 0.0170 \text{ W}^{\circ}\text{C}$$

$$\text{GL3} = \text{GL A-C (total)} = 0.0215 \text{ W}^{\circ}\text{C}.$$

The total GL as series of GL1, GL2 and GL3 = **0.0189 W/°C**; a sketch of the connections is reported below.

After the correlation activity related to the PFM#1 test, the total linear conductor between Cone and the Central Solar Array has been reduced to the value of **0.000945 W/°C** for the single contact, which correspond to a **GL = 0.01134 W/°C** for all 12 brackets.

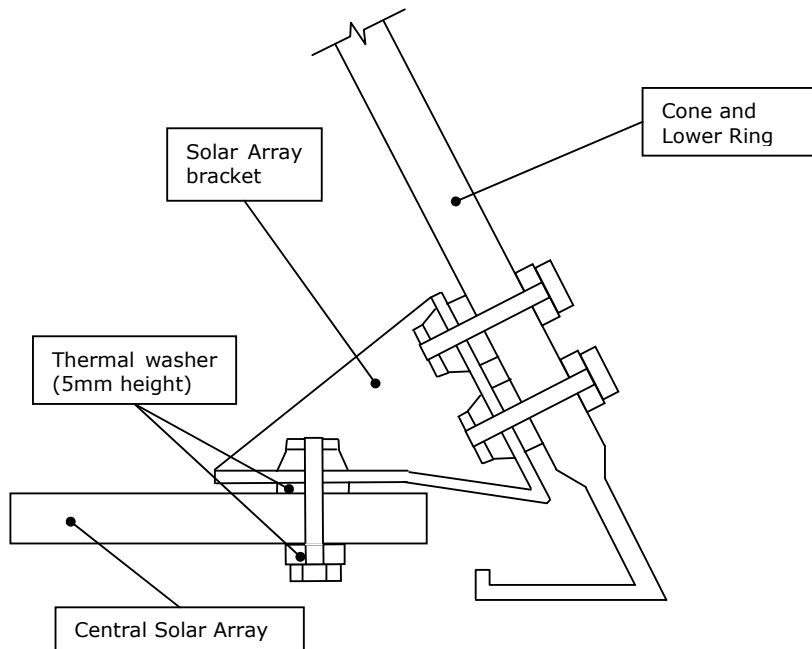
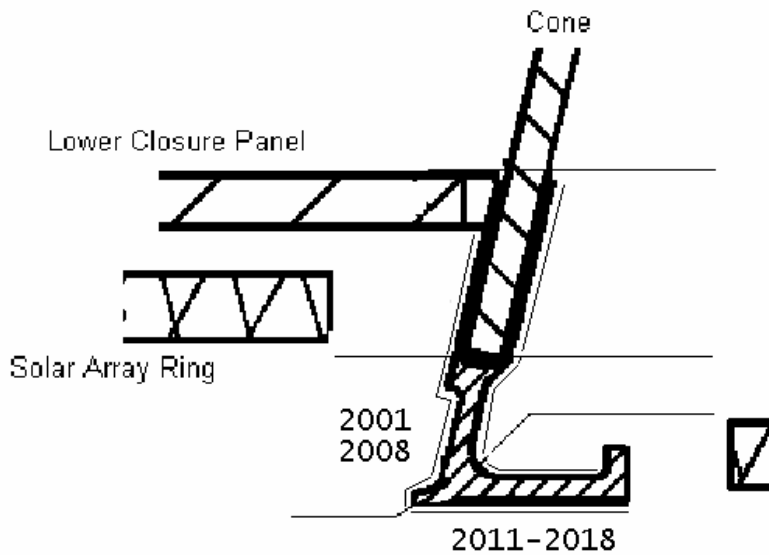

Figure 5.7-3 PLANCK – Connection Solar Array-Cone

5.8 LVA Ring modification after the PFM#1 test

In the frame of the correlation activity related to the PFM#1 test, the following modifications have been implemented on LVA ring thermal network.

1. The Thermo-optical properties change according to the following data:



Nodes 2001 – 2008: Alodine 1200 | $\alpha = 0.56$ / $\epsilon = 0.16$ (were $\alpha=0.5/\epsilon=0.5$)

Nodes 2011 – 2018: Part of Alodine 1200 and part of Silver Teflon tape | $\alpha_{eq} = 0.187$ / $\epsilon_{eq} = 0.638$
(were $\alpha_{eq}=0.157$ / $\epsilon_{eq}=0.601$)

2. The GL between the Lower Floor and the LVA ring (through the bracket) has been reduced to a total value of 0.05418 W/K respect to the initial value of 0.5418 W/K.
3. The conductive couplings between LVA ring and the Cone have increased by a factor of 10. Similar change was applied also on Herschel correlation analysis though with a lower multiplying factor, in any case has been verified with dedicated analysis, that the same value can be used also on Herschel with a negligible impact on units' temperature.

6 HERSCHEL & PLANCK MASS UPDATING

The thermal capacities of HERSCHEL and PLANCK satellites have been updated on the basis of the:

- BEE mechanical mass budget (H-P-BD-AI-0006 issue 2) relatively to the masses used to define the thermal capacity of the structure (panel, shear web, cone, adaptor ring etc.)
- Thermal ICD or dedicated RTMM relatively to the unit thermal capacities.

Starting from the mechanical mass budget, the masses (subdivide for panel) of the structure, brackets, filler, paint, radiator and harness have been identified and reported in the tables 6-2 for Herschel and 6-3 for Planck.

In the table 6-1 the comparison between the total mass of the satellites derived from mechanical mass budget and the total equivalent mass derived from the TMM is shown.

	Total BEE Mass Budget [Kg]	Total thermal Capacity in TMM [J/°C]	Equivalent Mass of thermal Capacity (*) [Kg]
HERSCHEL	891	742268	825
PLANCK	1103	841289	935

(*) considering a heat capacity of 900 J/Kg °C

Table 6-1 PLANCK – Summary mass comparison between TMM and mechanical mass budget

Description	Node	Brackets, filler, paint, radiator [Kg]	Harness [Kg]	SVM structure [Kg]	SVM Spread [Kg]	Thermal Capacity (*) [J/°C]
Panel +Z	30XX,60XX	0.13		6.3	7.02	12105
Panel +Y+Z	31XX, 61XX	0.34	3.27	4.99	4.67	10962
Panel +Y	32XX, 62XX	1.43	21.02	7.12	7.02	26625
Panel +Y-Z	33XX, 63XX	0.37	2.81	4.93	4.67	10659
Panel -Z	34XX, 64XX	0.39	3.7	7.4	7.02	15549
Panel -Y-Z	35XX, 65XX	0.23	3.66	5.36	4.67	11430
Panel -Y	36XX, 66XX	0.44	3.66	8.07	7.02	16173
Panel -Y+Z	37XX, 67XX	0.69	1.24	5	4.67	10068
Shear Web +Y(+Z)	526X	0.1		2.72		2538
Shear Web +Y(-Z)	528X			2.51		2259
Shear Web +Z(+Y)	507X	0.18		2.36		2286
Shear Web +Z(-Y)	505X	1.66		2.84		4050
Shear Web -Y(+Z)	568X			2.51		2259
Shear Web -Y(-Z)	566X			2.88		2592
Shear Web -Z(+Y)	546X			1.97		1773
Shear Web -Z(-Y)	548X			1.93		1737
Adaptor ring	201X,211X,202X,212X,200X,210X,205X,215X	3.6		32.5		32490
Cone	25XX,26XX			53.8		48420
Lower Closure	16XX	7	42.43	26.62		55716
Subplatform	24XX			5.29		4761
TH closure struct.	74XX	1.28		5.17		5805
Upper Closure	76XX	41.23	34.18	29.37		84048
Attached point	27XX			23.6		21240
Total		59.07	115.97	245.24	46.76	385545

(*) Considering the following specific heat: 600 J/Kg/°C for the harness; 900 J/Kg/°C for the other parts

Table 6-2 HERSCHEL – Mass Updating from BEE mechanical mass budget



Controlled Distribution

Should be noted that Herschel Star Tracker baseplate has been considered, in the TMM, with a thermal capacity of 3597 J/°C, corresponding to a mass of 4.9 Kg. In the mechanical mass budget the mass of the STR structure with harness and bracket is of 5.43 Kg. About the star tracker unit the same mass has been considered both in the TMM and in the mechanical mass budget (3.12 Kg).

Description	Node	Brackets, filler, paint, radiator [Kg]	Harness [Kg]	SVM structure [Kg]	SVM Spread [Kg]	Thermal Capacity ^(*) [J/°C]
Panel +Z	30XX,60XX	0.29	2.8	4.16	7.25	12210
Panel +Y+Z	31XX, 61XX	0.26	5.48	7.26	10.87	19839
Panel +Y	32XX, 62XX	0.29	8.47	4.72	7.25	16116
Panel +Y-Z	33XX, 63XX	0.18		7.47	10.87	16668
Panel -Z	34XX, 64XX	0.09	1.43	4.66	7.25	11658
Panel -Y-Z	35XX, 65XX	0.18	2	7.13	10.87	17562
Panel -Y	36XX, 66XX	0.25	3.42	4.68	7.25	13014
Panel -Y+Z	37XX, 67XX	0.84	24.78	6.89	10.87	31608
Shear Web +Y+Z(+Z)	515X,516X	0.01	6.21	2.85		6300
Shear Web +Y-Z(+Y)	525X,526X	0.7		2.85		3195
Shear Web +Y-Z(-Z)	527X,528X			2.69		2421
Shear Web -Y+Z(+Z)	507X,508X			2.46		2214
Shear Web +Y+Z(+Y)	517X,518X	0.45		2.59		2736
Shear Web -Y+Z(-Y)	505X,506X	0.21		2.73		2646
Shear Web -Y-Z(-Y)	535X,536X			2.74		2466
Shear Web -Y-Z(-Z)	537X,538X	0.24		2.63		2583
Adaptor ring	2XXX	3.4		32.5		32310
Cone	25XX,26XX	0		68.44		61596
Lower panel	16XX	6.68	40.26	19.45		47673
Subplatform	73XX,74XX,27XX	0.28	24.5	51		60852
Upper closure	76XX			21.08		18972
Attached point	1002X			15.9		14310
Total		14.35	119.35	276.88	72.48	398949

(*) Considering the following specific heat: 600 J/Kg/°C for the harness; 900 J/Kg/°C for the other parts

Table 6-3 PLANCK – Mass Updating from BEE mechanical mass budget

Controlled Distribution



REFERENCE : H-P-RP-AI-0040

DATE : 29/SEP/06

ISSUE : 06

Page : 131/405

7 SVM INTERFACE REQUIREMENTS

7.1 Herschel requirements

The HERSCHEL SVM interface requirements are listed below:

REQUIR.	DESCRIPTION	RESULT	STATUS (*)
ITP-030-H	CVV total negative conductive loads onto the SVM of 5W uniformly distributed on each point	Total negative flux of 5W on the 12 I/F CVV POINTS (2701÷2712) in the TMM	C
ITS-021-H	Sunshield total positive loads onto SVM of 5W from Sunshield CFRP struts and 10W from Sunshield brackets uniformly distributed on each point	Total positive flux of 5W on the 3 I/F SUNSHIELD STRUTS (2715÷2717) and 10W on the 2 I/F SUNSHIELD BRACKETS (2713-2714) in the TMM	C
ITP-040-H	SVM shield total negative loads onto SVM of 1W uniformly distributed on each point	Total negative flux of 1W on the 14 I/F SVM SHIELD POINTS (2718÷2731) in the TMM	C
ITP-050-H	Total negative loads onto FHLSU via wave-guides of 1W	Total negative flux of 1W on the FHLSU (605) in the TMM	C
ITP-060-H	Negative heat loads onto the SVM connector brackets of the upper panels < 1W	connector brackets not modelled	N/A
ITP-090-H	MLI on top SVM max decoupling	Low Emissivity ($\epsilon=0.05$) and MLI 20 layers used	C
ITP-100-H	MLI on top SVM composition $\epsilon < 0.05$, infra-red specular ratio > 90%, $\alpha = 0.13 \pm 0.02$, solar specular reflectivity 0.82 ± 0.02 and external layer T average (weighted by areas) < 220K (-43.6°C) for any pitch in the range [-30°,0°]	Composition and T < 220K for nodes 7001÷7078 and 7201÷7260 for any pitch in the range [-30°,0°] Average Temp = -35.5°C (Table 7.1-2)	NC
ITP-120-H	CVV truss attachment points T < 293K (20°C) for any pitch in the range [-30°,0°]	T < 293K on the 4 I/F CVV POINTS for any pitch in the range [-30°,0°] Average Temp = 25.9°C (Tab 7.1.3)	NC
ITP-130-H	SVM shield attachment points T < 293K (20°C) for any pitch in the range [-30°,0°]	T < 293K on 6 I/F SVM SHIELD POINTS for any pitch in the range [-30°,0°] Average T = 23.1°C (Table 7.14)	NC
ITP-135-H	Thermal conductive leak from the STR Assembly to HPLM < 150mW	Flux to CVV (Table 7.1-5)	C
ITI-020-H	Temp. design range and stability req.	Stability results: see Tables 7.1-6/7	C
		Temp. design range: see conclusions	PC
ACP-060-H	Maximum rate of temperature variation not exceeding 0.25 °C/100 sec at STR mounting plate	Detail see AD23 (Table 7.1-7/8)	C
	Amplitude of temperature variation within 0.5°C around any setpoint of STR	Detail see AD23 (Table 7.1-9/10)	C
	The maximum temperature gradient generated by STR at baseplate between mounting feet $\leq 0.4^\circ\text{C}$	Detail see AD23 (fig. 7.1-1 and 7.1-2)	C
THP-095-H	During observation period max temperature gradient between SVM/PLM I/F point < 8°C	Table 7.1-13	C
Para 4.1.2.1.20 of H-P-SP-AI-0007	STRs: to maintain in their operative range also in case of simultaneous operation of main and redundant sensors (monitoring of the redundant equipment while the nominal is used in nominal mode)	Para 8.4.4 redundancy analysis case C 2STR ON: 32.7°C of max Temperature versus 40°C of max operative limit	C
Para 4.1.2.1.20	GYRO: amplitude of temperature variation shall be	Para 8.4 with minmax in all the	C



Controlled Distribution



REFERENCE : H-P-RP-AI-0040

DATE : 29/SEP/06

ISSUE : 06

Page : 132/405

REQUIR.	DESCRIPTION	RESULT	STATUS (*)
of H-P-SP-AI-0007	maintained in a band of 5°C in range -25°C/+65°C (with a rate of 1°C/h)	nominal cases, Fig 7.1-3 for details, plots in Para 10	
Para 4.1.2.1.20 of H-P-SP-AI-0007	CRS: maintain the unit temperature around a variable set point with an accuracy of $\pm 0.5^\circ\text{C}$. Reach (with a positive margin of $+5^\circ\text{C}$) the CRS temperature in nominal mode starting from its temperature during the Survival mode.	Para 8.4 minmax in all the nominal cases, Fig 7.1-3 for details, power consumption in Survival 90% of duty cycle	C
Para 4.1.2.1.20 of H-P-SP-AI-0007	RWL not subjected to a thermal gradient higher than 1°C/h. Relaxed to 1.5°C/h during a transition (from Cold to Hot or vice versa).	Para 10 plot case Q (RWL operative)	C
Para 4.1.2.1.20 of H-P-SP-AI-0007	AAD amplitude of temperature variation in a band of 20°C in the operating range	Table 8.4.2-1 change of attitude results and Para 10 plots	C

(*) C=Compliance; NC= Not Compliance; PC= Partially Compliance

Table 7.1-1 HERSCHEL – Requirements

ITP-100-H

SVM Top external layer T average (wighted by areas) < 220K (-53°C) for the hottest pitch in the range [-30°,0°] and for the hottest dissipation case: EOL in Winter pitch 0° and Telecom MODE1

HERSCHEL ITP-100-H						
WORST CASE: EOL Rotx=-1 Roty=0 Winter Telecom MODE1						
NODE	LABEL	T [°C]	UFP [°C]	T+UFP [°C]	AREA [m ²]	(T+UFP)*AREA [°C*m ²]
7001	MLI SVM Top +Z	-49.24	24.6	-24.64	0.1385	-3.41
7002	MLI SVM Top +Z	-36.31	21.6	-14.71	0.1385	-2.04
7003	MLI SVM Top +Z	-47.36	24.4	-22.96	0.0703	-1.62
7004	MLI SVM Top +Z	-34.63	21.4	-13.23	0.0703	-0.93
7005	MLI SVM Top +Z	-46.9	24.3	-22.6	0.0703	-1.59
7006	MLI SVM Top +Z	-33.6	21.5	-12.1	0.0703	-0.85
7007	MLI SVM Top +Z	-48.17	24.7	-23.47	0.1385	-3.25
7008	MLI SVM Top +Z	-33.31	21.5	-11.81	0.1385	-1.64
7011	MLI SVM Top +Y+Z	-49.56	24.5	-25.06	0.0801	-2.01
7012	MLI SVM Top +Y+Z	-33.66	21.4	-12.26	0.1015	-1.24
7013	MLI SVM Top +Y+Z	-49.88	24.6	-25.28	0.0530	-1.34
7014	MLI SVM Top +Y+Z	-35.01	21.8	-13.21	0.1591	-2.10
7015	MLI SVM Top +Y+Z	-50.99	24.8	-26.19	0.0530	-1.39
7016	MLI SVM Top +Y+Z	-40.71	23.2	-17.51	0.1591	-2.79
7017	MLI SVM Top +Y+Z	-51.72	25	-26.72	0.0801	-2.14
7018	MLI SVM Top +Y+Z	-48.42	25.1	-23.32	0.1015	-2.37
7021	MLI SVM Top +Y	-56.2	25.4	-30.8	0.1385	-4.27
7022	MLI SVM Top +Y	-56.59	25.6	-30.99	0.1385	-4.29
7023	MLI SVM Top +Y	-58.11	25.3	-32.81	0.0703	-2.31
7024	MLI SVM Top +Y	-58.94	25.5	-33.44	0.0703	-2.35



Controlled Distribution



REFERENCE : H-P-RP-AI-0040

DATE : 29/SEP/06

ISSUE : 06

Page : 133/405

HERSCHEL ITP-100-H						
WORST CASE: EOL Rotx=-1 Roty=0 Winter Telecom MODE1						
NODE	LABEL	T [°C]	UFP [°C]	T+UFP [°C]	AREA [m ²]	(T+UFP)*AREA [°C*m ²]
7025	MLI SVM Top +Y	-59.25	25.4	-33.85	0.0703	-2.38
7026	MLI SVM Top +Y	-59.86	25.7	-34.16	0.0703	-2.40
7027	MLI SVM Top +Y	-60.67	25.6	-35.07	0.1385	-4.86
7028	MLI SVM Top +Y	-60.54	26	-34.54	0.1385	-4.78
7031	MLI SVM Top +Y-Z	-64.51	25.7	-38.81	0.0801	-3.11
7032	MLI SVM Top +Y-Z	-66.22	25.9	-40.32	0.1015	-4.09
7033	MLI SVM Top +Y-Z	-64.9	25.8	-39.1	0.0530	-2.07
7034	MLI SVM Top +Y-Z	-66.93	26	-40.93	0.1591	-6.51
7035	MLI SVM Top +Y-Z	-64.69	25.8	-38.89	0.0530	-2.06
7036	MLI SVM Top +Y-Z	-65.02	25.8	-39.22	0.1591	-6.24
7037	MLI SVM Top +Y-Z	-64.61	25.8	-38.81	0.0801	-3.11
7038	MLI SVM Top +Y-Z	-64.7	26	-38.7	0.1015	-3.93
7039	MLI SVM Top +Y-Z	-65.43	26	-39.43	0.1385	-5.46
7040	MLI SVM Top +Y-Z	-64.91	26.1	-38.81	0.1385	-5.37
7041	MLI SVM Top -Z	-66.32	26	-40.32	0.0703	-2.84
7042	MLI SVM Top -Z	-66.18	26.1	-40.08	0.0703	-2.82
7043	MLI SVM Top -Z	-66.16	26.2	-39.96	0.0703	-2.81
7044	MLI SVM Top -Z	-66.23	26.2	-40.03	0.0703	-2.82
7051	MLI SVM Top -Z-Y	-65.52	26.1	-39.42	0.1385	-5.46
7052	MLI SVM Top -Z-Y	-65.08	26.3	-38.78	0.1385	-5.37
7053	MLI SVM Top -Z-Y	-65.22	26.1	-39.12	0.0801	-3.13
7054	MLI SVM Top -Z-Y	-65.51	26.2	-39.31	0.1015	-3.99
7055	MLI SVM Top -Z-Y	-65.32	26	-39.32	0.0530	-2.09
7056	MLI SVM Top -Z-Y	-68.02	25.3	-42.72	0.1591	-6.80
7057	MLI SVM Top -Z-Y	-65.05	25.9	-39.15	0.0530	-2.08
7058	MLI SVM Top -Z-Y	-66.37	25.6	-40.77	0.1591	-6.49
7059	MLI SVM Top -Y	-64.31	25.8	-38.51	0.0801	-3.08
7060	MLI SVM Top -Y	-65.36	25.8	-39.56	0.1015	-4.02
7061	MLI SVM Top -Y	-61.84	26	-35.84	0.1385	-4.96
7062	MLI SVM Top -Y	-62	25.4	-36.6	0.1385	-5.07
7063	MLI SVM Top -Y	-60.82	26	-34.82	0.0703	-2.45
7064	MLI SVM Top -Y	-61.11	25.1	-36.01	0.0703	-2.53
7065	MLI SVM Top -Y	-59.49	25.9	-33.59	0.0703	-2.36
7066	MLI SVM Top -Y	-59.85	24.8	-35.05	0.0703	-2.47
7067	MLI SVM Top -Y	-58.26	25.8	-32.46	0.1385	-4.50
7068	MLI SVM Top -Y	-57.45	25.5	-31.95	0.1385	-4.42
7071	MLI SVM Top -Y+Z	-54.81	25.5	-29.31	0.0801	-2.35
7072	MLI SVM Top -Y+Z	-51.42	25.5	-25.92	0.1015	-2.63
7073	MLI SVM Top -Y+Z	-53.78	25.2	-28.58	0.0530	-1.52
7074	MLI SVM Top -Y+Z	-44.16	23.2	-20.96	0.1591	-3.33
7075	MLI SVM Top -Y+Z	-52.55	25.1	-27.45	0.0530	-1.46



Controlled Distribution



REFERENCE : H-P-RP-AI-0040

DATE : 29/SEP/06

ISSUE : 06

Page : 134/405

HERSCHEL ITP-100-H						
WORST CASE: EOL Rotx=-1 Roty=0 Winter Telecom MODE1						
NODE	LABEL	T [°C]	UFP [°C]	T+UFP [°C]	AREA [m ²]	(T+UFP)*AREA [°C*m ²]
7076	MLI SVM Top -Y+Z	-39.68	22.2	-17.48	0.1591	-2.78
7077	MLI SVM Top -Y+Z	-51.29	25	-26.29	0.0801	-2.10
7078	MLI SVM Top -Y+Z	-36.96	21.7	-15.26	0.1015	-1.55
7200	MLI SVM Top Disc Int +Z	-52.83	24.6	-28.23	0.5144	-14.52
7201	MLI SVM Top Disc Int +Z+	-55.13	24.9	-30.23	0.1580	-4.78
7202	MLI SVM Top Disc Int +Y	-59.66	25.4	-34.26	0.5144	-17.62
7203	MLI SVM Top Disc Int +Y-	-65.35	26.3	-39.05	0.3250	-12.69
7204	MLI SVM Top Disc Int -Z	-66.24	26.6	-39.64	0.1787	-7.08
7205	MLI SVM Top Disc Int -Z-	-65.37	26.4	-38.97	0.3216	-12.53
7206	MLI SVM Top Disc Int -Y	-59.56	25.7	-33.86	0.5144	-17.42
7207	MLI SVM Top Disc Int -Y+	-55.39	25	-30.39	0.1580	-4.80
7210	MLI Cyl STR Int +Z	-55.1	22.9	-32.2	0.2513	-8.09
7211	MLI Cyl STR Int +Z+Y	-55.14	23.2	-31.94	0.0771	-2.46
7212	MLI Cyl STR Int +Y	-60.3	22.2	-38.1	0.2513	-9.57
7213	MLI Cyl STR Int +Y-Z	-58.85	22.3	-36.55	0.1586	-5.80
7214	MLI Cyl STR Int -Z	-59.53	22.2	-37.33	0.0880	-3.29
7215	MLI Cyl STR Int -Z-Y	-59.2	22.7	-36.5	0.1580	-5.77
7216	MLI Cyl STR Int -Y	-60.39	22.3	-38.09	0.2513	-9.57
7217	MLI Cyl STR Int -Y+Z	-55.79	23.3	-32.49	0.0771	-2.51
7220	MLI Disc STR Int +Z	-88.94	15.1	-73.84	0.1853	-13.68
7221	MLI Disc STR Int +Z+Y	-79.94	17.2	-62.74	0.0569	-3.57
7222	MLI Disc STR Int +Y	-74.11	17.9	-56.21	0.1853	-10.42
7223	MLI Disc STR Int +Y-Z	-97.6	17.1	-80.5	0.1170	-9.42
7224	MLI Disc STR Int -Z	-67.22	18.4	-48.82	0.0647	-3.16
7225	MLI Disc STR Int -Z-Y	-89.49	17.7	-71.79	0.1161	-8.34
7226	MLI Disc STR Int -Y	-76.28	18	-58.28	0.1853	-10.80
7227	MLI Disc STR Int -Y+Z	-81.91	17.1	-64.81	0.0569	-3.69
7230	MLI Rec STR dx	-79.07	23	-56.07	0.0101	-0.57
7231	MLI Rec STR dx	-80.52	21	-59.52	0.0101	-0.60
7232	MLI Rec STR dx	-80.76	20	-60.76	0.0101	-0.61
7233	MLI Rec STR dx	-80.59	18.9	-61.69	0.0101	-0.62
7234	MLI Rec STR dx	-80.16	18.4	-61.76	0.0101	-0.62
7235	MLI Rec STR dx	-80.02	18.1	-61.92	0.0101	-0.62
7236	MLI Rec STR dx	-78.82	18.1	-60.72	0.0101	-0.61
7237	MLI Rec STR dx	-77.54	18.4	-59.14	0.0101	-0.60
7238	MLI Rec STR dx	-76.46	18.8	-57.66	0.0101	-0.58
7239	MLI Rec STR dx	-74.66	20.4	-54.26	0.0101	-0.55
7240	MLI Rec STR dx	-71.68	21.4	-50.28	0.0101	-0.51
7250	MLI Rec STR sx	-79.51	23	-56.51	0.0101	-0.57
7251	MLI Rec STR sx	-80.84	21.1	-59.74	0.0101	-0.60
7252	MLI Rec STR sx	-81.12	19.9	-61.22	0.0101	-0.62



Controlled Distribution



REFERENCE : H-P-RP-AI-0040

DATE : 29/SEP/06

ISSUE : 06

Page : 135/405

HERSCHEL ITP-100-H						
WORST CASE: EOL Rotx=-1 Roty=0 Winter Telecom MODE1						
NODE	LABEL	T [°C]	UFP [°C]	T+UFP [°C]	AREA [m ²]	(T+UFP)*AREA [°C*m ²]
7253	MLI Rec STR sx	-80.7	19	-61.7	0.0101	-0.62
7254	MLI Rec STR sx	-80.22	18.1	-62.12	0.0101	-0.63
7255	MLI Rec STR sx	-80.12	17.7	-62.42	0.0101	-0.63
7256	MLI Rec STR sx	-78.86	18.2	-60.66	0.0101	-0.61
7257	MLI Rec STR sx	-77.62	18.4	-59.22	0.0101	-0.60
7258	MLI Rec STR sx	-76.37	19.1	-57.27	0.0101	-0.58
7259	MLI Rec STR sx	-74.88	20	-54.88	0.0101	-0.55
7260	MLI Rec STR sx	-71.52	21.3	-50.22	0.0101	-0.51
	Average					-415.1
	Total	-62.9			11.7	-35.5
	Weighted on Areas					

Table 7.1-2 HERSCHEL - REQ ITP-100-H

ITP-120-H

CVV truss attachment points T <293 K (20°C) for the hottest pitch in the range [-30°,0°] and for the hottest dissipation case: EOL in Winter pitch 0° and Telecom MODE1

HERSCHEL ITP-120-H				
WORST CASE: EOL Rotx=-1 Roty=0 Wnter Telecom MODE1				
NODE	LABEL	T [°C]	UFP [°C]	T+UFP [°C]
2701	I/F CVV	25.6	7.0	32.6
2702	I/F CVV	24.4	7.2	31.6
2703	I/F CVV	20.3	7.4	27.7
2704	I/F CVV	19.2	7.4	26.6
2705	I/F CVV	12.7	7.6	20.3
2706	I/F CVV	12.6	7.6	20.2
2707	I/F CVV	12.3	7.5	19.8
2708	I/F CVV	12.3	7.5	19.8
2709	I/F CVV	17.5	7.5	25.0
2710	I/F CVV	18.3	7.5	25.8
2711	I/F CVV	21.8	7.5	29.3
2712	I/F CVV	25.2	7.1	32.3
	Average	18.5		25.9

Table 7.1-3 HERSCHEL - REQ ITP-120-H



Controlled Distribution



REFERENCE : H-P-RP-AI-0040

DATE : 29/SEP/06

ISSUE : 06

Page : 136/405

ITP-130-H

SVM shield attachment points $T < 293 \text{ K}$ (20°C) for the hottest pitch in the range $[-30^\circ, 0^\circ]$ and for the hottest dissipation case: EOL in Winter pitch 0° and Telecom MODE1

HERSCHEL ITP-130-H				
WORST CASE: EOL Rotx=-1 Roty=0 Wnter Telecom MODE1				
NODE	LABEL	T	UFP	T+UFP
		[°C]	[°C]	[°C]
2718	I/F R1 SVM SHIELD +Y	22.0	7.4	29.4
2719	I/F T1 SVM SHIELD +Y	19.0	7.5	26.5
2720	I/F T2 SVM SHIELD +Y	14.2	7.5	21.7
2721	I/F T3 SVM SHIELD -Z	13.2	7.7	20.9
2722	I/F T4 SVM SHIELD -Z	12.9	7.5	20.4
2723	I/F T5 SVM SHIELD -Y	14.2	7.2	21.4
2724	I/F T6 SVM SHIELD -Y	17.9	7.3	25.2
2725	I/F R2 SVM SHIELD -Y	20.3	7.5	27.8
2726	I/F SS1 SVM SHIELD +Y	18.8	7.4	26.2
2727	I/F SS2 SVM SHIELD +Y-Z	12.3	7.6	19.9
2728	I/F SS3 SVM SHIELD -Y-Z	12.0	7.5	19.5
2729	I/F SS4 SVM SHIELD -Y	17.1	7.5	24.6
2730	I/F SS5 SVM SHIELD -Z	11.9	7.5	19.4
2731	I/F SS6 SVM SHIELD -Z	12.3	7.6	19.9
Average		15.6		23.1

Table 7.1-4 HERSCHEL - REQ ITP-130-H

ITP-135-H

Thermal conductive leak from the STR assembly to the HPLM for all the Sizing Cases defined in AD9 < 150mW

HERSCHEL ITP-135-H						
Case	Prop.	Description	SEASON	POWER	Analysis type	Flux to CVV [mW]
A	EOL	RotX=+1, RotY=-30	Winter	TelecomE/mode 1	Transient	0.124
B	EOL	RotX=+1, RotY=-30	Winter	TelecomE/mode 2 photometry	Transient	0.125
C	EOL	RotX=+1, RotY=-30	Winter	TelecomE/mode 2 spectroscopy	Transient	0.125
D	EOL	RotX=-1, RotY=-30	Winter	TelecomE/mode 1	Transient	0.124
E	EOL	RotX=-1, RotY=-30	Winter	TelecomE/mode 2 photometry	Transient	0.125
F	EOL	RotX=-1, RotY=-30	Winter	TelecomE/mode 2 spectroscopy	Transient	0.125
G	BOL	RotX=-1, RotY=+30	Summer	Scientific/mode 3	Transient	0.089
H	BOL	RotX=-1, RotY=+30	Summer	Scientific/mode 1	Transient	0.089
I	BOL	RotX=+5, RotY=0	Summer	Survival	Transient	0.087

Table 7.1-5 HERSCHEL REQ ITP-135-H



Controlled Distribution



REFERENCE : H-P-RP-AI-0040

DATE : 29/SEP/06

ISSUE : 06

Page : 137/405

ITI-020-H

Preliminary verification and concept validation have been performed by AAS-I. Final verification, applicable to all the involved units, is still to be performed pending confirmation of stability requirements and I/F point control verification. AAS-I is waiting CR related these points (see H-P-ASP-MN-7404, dated 8/2/06). Based on this last step, all the necessary modifications (HW and SW) will be then imposed to the applicable suppliers.

ITI-020-H		COLD CASE P		
Node number	Unit name	Max [K/s]	Req. [K/s]	Compl/Not-Compl
424	HSDCU	0.000245	0.000833333	Compl
425	HSDPU	0.000223	0.000833333	Compl
426	HSFCU	0.000231	0.000833333	Compl
654007	PANEL UNDER FOOT	0.000032	0.0003	Compl
521	FHWOV	0.000036	0.0003	Compl
522	FHHRV	0.00009	0.0003	Compl
523	FHICU	0.000107	0.0014	Compl
524	FHFCU	0.0001	0.0014	Compl
526	FHWEV	0.000087	0.0003	Compl
507	FHIFV	0.000098	0.0003	Compl
508	FHWIH IFV-HRV	0.0001	0.0014	Compl
509	FHWIH IFV-WEV	0.000098	0.0014	Compl
510	FHWIH WEV-WOV	0.000102	0.0014	Compl
511	FHWIH HRV-HRH	0.000126	0.0014	Compl
660706	PANEL UNDER FOOT	0.000163	0.0003	Compl
621	FHWOH	0.000045	0.0003	Compl
622	FHWEH	0.000154	0.0003	Compl
623	FHHRH	0.0001	0.0003	Compl
624	FHLCU	0.000121	0.0003	Compl
625	FHLSU	0.000103	0.0003	Compl
606	FHIFH	0.000138	0.0003	Compl
607	FHWIH IFH-HRH	0.000202	0.0014	Compl
608	FHWIH IFH-WEH	0.000196	0.0014	Compl
609	FHWIH WEH-WHO	0.000123	0.0014	Compl

Table 7.1-6 HERSCHEL stability requirement (Cold case)



Controlled Distribution

ITI-020-H		HOT CASE Q		
Node number	Unit name	Max [K/s]	Req. [K/s]	Compl/Not-Compl
424	HSDCU	0.000292	0.000833333	Compl
425	HSDPU	0.000262	0.000833333	Compl
426	HSFCU	0.000271	0.000833333	Compl
654007	PANEL UNDER FOOT	0.000032	0.0003	Compl
521	FHWOV	0.000036	0.0003	Compl
522	FHHRV	0.000103	0.0003	Compl
523	FHICU	0.000118	0.0014	Compl
524	FHFCU	0.000116	0.0014	Compl
526	FHWEV	0.0001	0.0003	Compl
507	FHIFV	0.000113	0.0003	Compl
508	FHWIH IFV-HRV	0.000117	0.0014	Compl
509	FHWIH IFV-WEV	0.000115	0.0014	Compl
510	FHWIH WEV-WOV	0.000121	0.0014	Compl
511	FHWIH HRV-HRH	0.000153	0.0014	Compl
660706	PANEL UNDER FOOT	0.000163	0.0003	Compl
621	FHWOH	0.00005	0.0003	Compl
622	FHWEH	0.000172	0.0003	Compl
623	FHHRH	0.00013	0.0003	Compl
624	FHLCU	0.000143	0.0003	Compl
625	FHLSU	0.000126	0.0003	Compl
606	FHIFH	0.000157	0.0003	Compl
607	FHWIH IFH-HRH	0.000222	0.0014	Compl
608	FHWIH IFH-WEH	0.000216	0.0014	Compl
609	FHWIH WEH-WHO	0.000144	0.0014	Compl

Table 7.1-7 HERSCHEL stability requirement (Hot case)

ACP-060-H

Maximum rate of temperature variation not exceeding 0.25 °C/100 sec at STR mounting plate I/F:

COLD CASE P				
Node number	Unit name	Max $\Delta T/\Delta t$ [K/s]	Req. [K/s]	Compl/Not-Compl
20014	STR Mounting plate I/F	0.001028	0.0025	Compl
20015	STR Mounting plate I/F	0.001053	0.0025	Compl
20022	STR Mounting plate I/F	0.001005	0.0025	Compl
20023	STR Mounting plate I/F	0.001008	0.0025	Compl
80027	STR Foot	0.000145	0.0025	Compl
80028	STR Foot	0.000105	0.0025	Compl
80029	STR Foot	0.000138	0.0025	Compl
80030	STR Foot	0.000101	0.0025	Compl

Table 7.1-8 HERSCHEL STR stability requirement (Cold case)

HOT CASE Q				
Node number	Unit name	Max $\Delta T/\Delta t$ [K/s]	Req. [K/s]	Compl/Not-Compl
20014	STR Mounting plate I/F	0.001128	0.0025	Compl
20015	STR Mounting plate I/F	0.001158	0.0025	Compl
20022	STR Mounting plate I/F	0.00108	0.0025	Compl
20023	STR Mounting plate I/F	0.00109	0.0025	Compl
80027	STR Foot	0.000144	0.0025	Compl
80028	STR Foot	0.000107	0.0025	Compl
80029	STR Foot	0.000158	0.0025	Compl
80030	STR Foot	0.000104	0.0025	Compl

Table 7.1-9 HERSCHEL STR stability requirement (Hot case)

Controlled Distribution



REFERENCE : H-P-RP-AI-0040

DATE : 29/SEP/06

ISSUE : 06

Page : 140/405

ACP-060-H

Amplitude of temperature variation within 0.5 °C around any setpoint of STR

UNIT	Max variation during transient[°C]	Req. [°C]	Compl/Not-Compl
STR feet	80027 = 0.218 80028 = 0.21 80029 = 0.213 80030 = 0.211	0.5	Compl

Table 7.1-10 HERSCHEL STR stability requirement (Cold Case)

UNIT	Max variation during transient[°C]	Req. [°C]	Compl/Not-Compl
STR feet	80027 = 0.276 80028 = 0.267 80029 = 0.27 80030 = 0.268	0.5	Compl

Table 7.1-11 HERSCHEL STR stability requirement (Hot Case)



Controlled Distribution

ACP-060-H

The maximum temperature gradient generated by STR at baseplate between mounting feet ≤ 0.4 °C

UNIT	Temp. gradient between the mounting feet [°C]	Req. [°C]	Compl/Not-Compl
STR mount. Feet	See Fig 4.1-1	0.6	Compl.

Table 7.1-12a HERSCHEL STR stability requirement (Cold Case)

UNIT	Temp. gradient between the mounting feet [°C]	Req. [°C]	Compl/Not-Compl
STR mount. Feet	See Fig 4.1-2	0.6	Compl.

Table 7.1-12b HERSCHEL STR stability requirement (Hot Case)

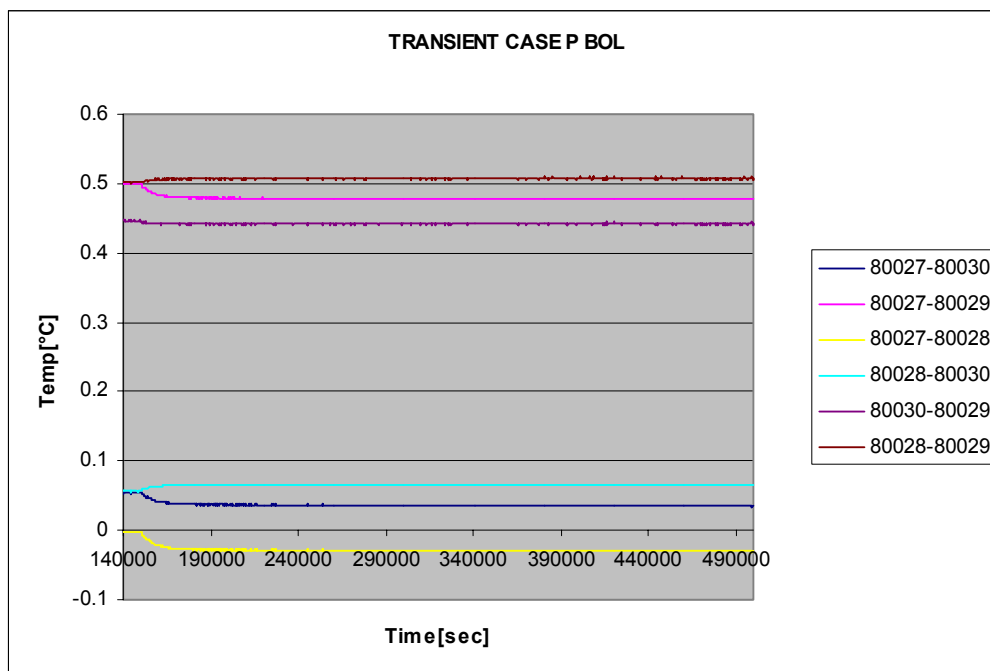

Figure 7.1-1 HERSCHEL STR feet temperature gradient (COLD CASE P)

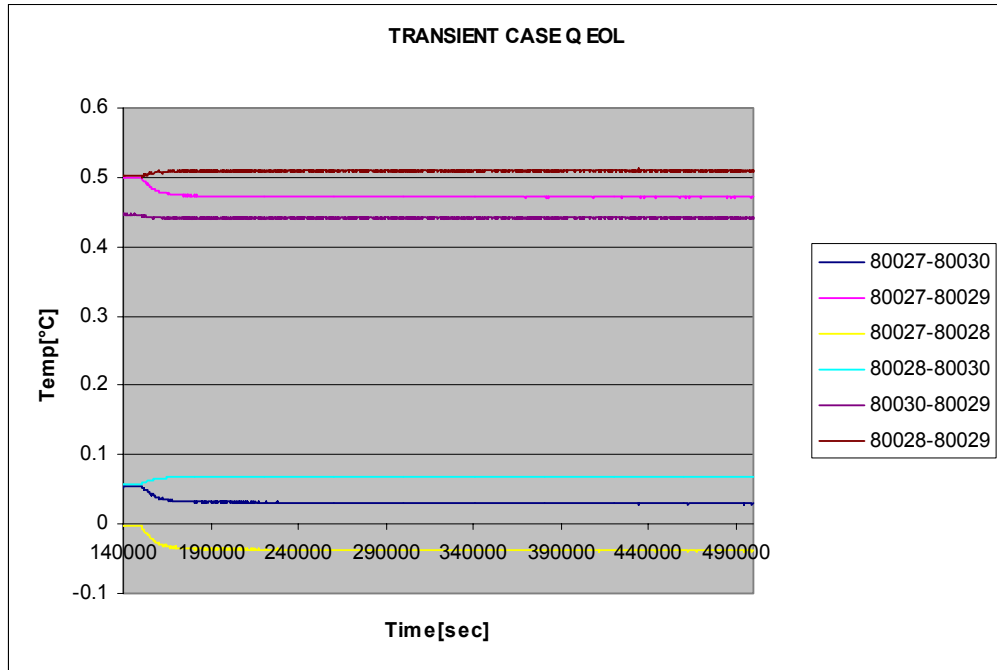

Figure 7.1-2 HERSCHEL STR feet temperature gradient (HOT CASE Q)

Controlled Distribution

THP-095-H

The requirement relevant to the maximum variation of the gradient of the I/F points, has been evaluated during a change of attitude both in COLD and HOT case comparing couples of I/F points covering all the combinations.

Intf. point #1	Intf. point #2	COLD CASE P	HOT CASE Q
		Max gradient variation [°C]	Max gradient variation [°C]
2701	2702	2.5	2.6
2701	2703	3.1	4.6
2701	2704	3.8	4.6
2701	2705	3.2	3.8
2701	2706	3.3	3.9
2701	2707	2.5	2.9
2701	2708	2.3	2.7
2701	2709	2.1	2.4
2701	2710	2.2	2.4
2701	2711	1.5	1.3
2701	2712	0.4	0.4
2702	2703	2.2	4.4
2702	2704	2.9	4.5
2702	2705	4.5	5.0
2702	2706	4.6	5.1
2702	2707	4.8	5.3
2702	2708	4.6	5.1
2702	2709	4.2	4.8
2702	2710	4.2	4.7
2702	2711	3.5	2.7
2702	2712	2.5	3.0
2703	2704	0.4	0.4
2703	2705	2.6	2.8
2703	2706	2.6	2.8
2703	2707	3.8	4.3
2703	2708	3.8	4.3
2703	2709	3.2	2.7
2703	2710	3.2	2.2
2703	2711	3.2	3.1
2703	2712	2.3	4.8
2704	2705	2.4	2.5
2704	2706	2.4	2.5

Controlled Distribution

Intf. point #1	Intf. point #2	COLD CASE P	HOT CASE Q
		Max gradient variation [°C]	Max gradient variation [°C]
2704	2707	3.5	4.0
2704	2708	3.6	4.0
2704	2709	3.0	2.2
2704	2710	2.8	2.7
2704	2711	3.0	4.1
2704	2712	3.2	4.8
2705	2706	0.1	0.1
2705	2707	1.3	1.6
2705	2708	1.4	1.8
2705	2709	1.3	2.1
2705	2710	1.3	2.1
2705	2711	1.8	3.0
2705	2712	3.2	3.8
2706	2707	1.3	1.7
2706	2708	1.4	1.8
2706	2709	1.3	2.1
2706	2710	1.3	2.1
2706	2711	1.8	3.1
2706	2712	3.3	3.9
2707	2708	0.2	0.3
2707	2709	0.7	0.6
2707	2710	0.7	0.6
2707	2711	0.8	1.7
2707	2712	2.2	2.6
2708	2709	0.6	0.5
2708	2710	0.7	0.6
2708	2711	0.6	1.5
2708	2712	2.0	2.4
2709	2710	0.1	0.1
2709	2711	0.7	1.2
2709	2712	2.1	2.1
2710	2711	0.7	1.3
2710	2712	2.1	2.2



Controlled Distribution

Intf. point #1	Intf. point #2	COLD CASE P	HOT CASE Q
		Max gradient variation [°C]	Max gradient variation [°C]
2711	2712	2.1	2.2

Table 7.1-13 HERSCHEL temperature gradient of SVM/PLM I/F points
PARA 4.1.2.1.20 OF H-P-SP-AI-0007

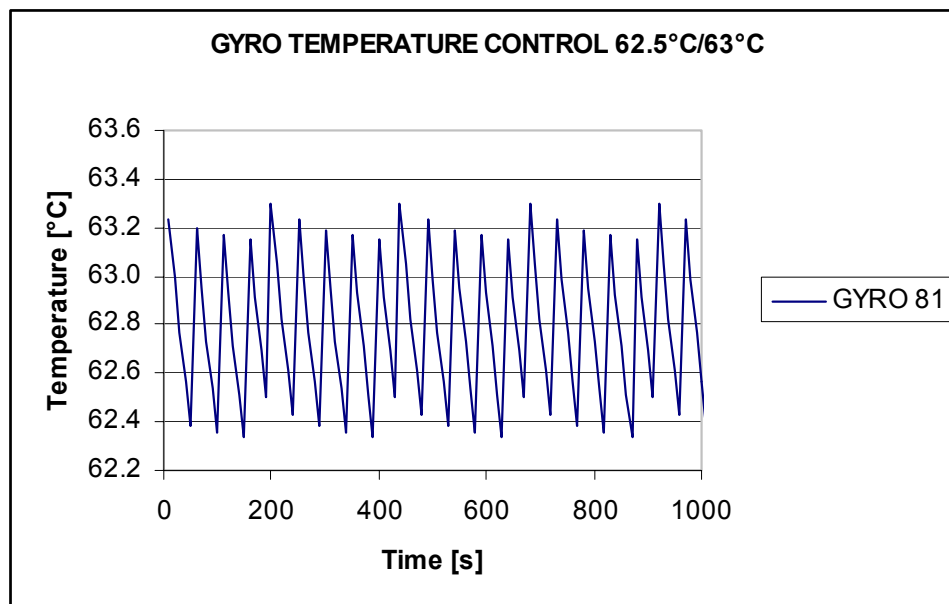

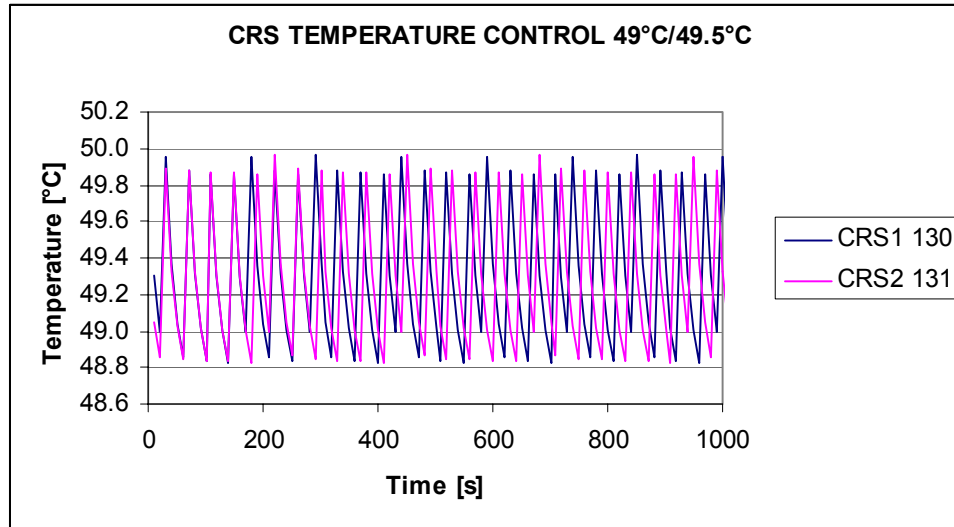

Figure 7.1-3 HERSCHEL temperature control of GYRO and CRS every 10 seconds

Controlled Distribution

7.2 Planck requirements

The PLANCK SVM interface requirements are listed below:

REQUIR.	DESCRIPTION	RESULT	STATUS (*)
ITP-140-P	MLI blankets with high efficiency installed on the top of SVM upper panels.	Node 7001-7008 : $\epsilon=0.04$; 20 layers	C
ITP-150-P	Specific characteristic of the subplatform MLI blankets Ext layer temperature <220K (< -53.15 °C)	Nodes 7201-7238 $\alpha=0.15 / \epsilon=0.04$ Avg Max temperature -30.2°C (Table 7.2-2)	NC
ITP-170-P	Radiative load from BEU-PAU $\leq 2.3W$	Max heat flux = 3.76W (Table 7.2-6, 7.2-7)	NC
ITP-180-P	Specific characteristic of BEU/PAU MLI blankets Ext layer temperature <235K (< -38.15 °C)	Nodes 7521-7522 $\alpha=0.15 / \epsilon=0.04$ Max temperature -43.9°C (Table 7.2-3)	C
ITP-190-P	Back side of Solar Array must be covered with MLI	MLI nodes 8101-8104	C
ITP-200-P	Specific characteristic of the MLI blankets on the back side of the Solar Array Ext layer temperature <300K (< 26.85 °C)	Nodes 8101-8104 $\alpha=0.15 / \epsilon=0.04$ Max temperature 29.1°C (Table 7.2-4)	NC
ITP-210-P	The temperature of P-PLM truss attachment points < 310K (<36.85 °C)	Nodes 10021-10026 Max temperature 29.2°C (Table 7.2-5)	C
ITP-220-P	Temperature stability at I/F truss point $\leq 0.02K$	Nodes 10021 – 10026 Results in Table 7.2-8	C
ITP-230-P	Temperature stability at radiative panels level $\leq 0.01K Hz^{1/2}$	Results in Table 7.2.9	C
ITI-030-P	Keep HFI and LFI instruments in their design range and under maximum temperature stability requirements. PAU: <ul style="list-style-type: none"> • Requirement: $\pm 3 K/hour$ • Goal : $\pm 1.1 K/hour$ BEU, DAE: <ul style="list-style-type: none"> • Requirement: $\pm 3 K/hour$ • Goal : $\pm 0.2 K/hour$ 	See temperature results of HFI and LFI units Stability requirement in table 7.2-10	C
ITI-040-P	SCC: <ul style="list-style-type: none"> - use a very emissive coating for radiative panels - discouple SCC panels - make use of a heat pipe network 	<ul style="list-style-type: none"> - panels with $\epsilon=0.87$ - titanium cleats between SCC panel and contiguous parts - heat pipe network AD8 	C
ITP-070-P	SVM compatible with PPLM as described in AD19	Model taken from doc. AD19	C
ITP-080_P	SVM compatible with negative load of 5W distributed over 6 nodes	Negative load flux applied onto nodes 10021-10026	C
ITI-010-P	SVM compatible with negative heat flow on BEU through wave guides (15W cold case / 0W hot case)	Applied on power dissipation value	C

Controlled Distribution



REFERENCE : H-P-RP-AI-0040

DATE : 29/SEP/06

ISSUE : 06

Page : 148/405

SCC Stability	Bed fluctuation: ± 3K for first adjacent element ± 1K for the next adjacent element ± 0.5 for next most element	Results in tables 7.2-11	NC
TANK stability	The gradient between each tank shall be less than 0.1 over one hour, 0.25 °C over one day and 1.5 °C over life	Results in Table 7.2.12	C
Para 4.1.2.1.20 of H-P-SP-AI-0007	STRs: to maintain in their operative range also in case of simultaneous operation of main and redundant sensors (monitoring of the redundant equipment while the nominal is used in nominal mode)	Para 8.5.4.3 redundancy analysis case C with two STRs ON: 25.0°C of max Temperature versus 40°C of max operative limit	C
Para 4.1.2.1.20 of H-P-SP-AI-0007	CRS: maintain the unit temperature around a variable set point with an accuracy of +0.5°C. Reach (with a positive margin of +5°C) the CRS temperature in nominal mode starting from its temperature during the Survival mode.	Heater lines thresholds set at: 48.0 / 48.5 °C - CRS1 & 2 35.0 / 35.5 °C - CRS3	C
Para 4.1.2.1.20 of H-P-SP-AI-0007	AAD amplitude of temperature variation in a band of 20°C in the operating range	Table 8.5.4.2-1 change of attitude results	C

(*) C=Compliance; NC= Not Compliance; PC= Partially Compliance

Table 7.2-1 PLANCK – SVM I/F requirements

PLANCK ITP-150-P						
WORST HOT CASE: EOL Rotx=-10						
NODE	LABEL	Temperature [°C]	UFP [°C]	T+UFP [°C]	Area [m²]	T+UFP * Area
7201	MLI SVM Top Disc +Y+Z	-51.92	24.7	-27.22	0.041	-1.116
7202	MLI SVM Top Disc +Y+Z	-53.13	24.7	-28.43	0.0481	-1.367
7203	MLI SVM Top Disc +Y+Z	-54.31	24.5	-29.81	0.0475	-1.416
7204	MLI SVM Top Disc +Y+Z	-55.77	24.9	-30.87	0.0805	-2.485
7205	MLI SVM Top Disc +Y+Z	-55.65	24.8	-30.85	0.0385	-1.188
7206	MLI SVM Top Disc +Y+Z	-56.33	24.8	-31.53	0.0414	-1.305
7207	MLI SVM Top Disc +Y+Z	-56.53	24.7	-31.83	0.0387	-1.232
7208	MLI SVM Top Disc +Y+Z	-57.00	24.7	-32.30	0.0304	-0.982
7209	MLI SVM Top Disc +Y+Z	-56.45	24.4	-32.05	0.0282	-0.904
7210	MLI SVM Top Disc +Y+Z	-56.42	24.5	-31.92	0.0255	-0.814
7211	MLI SVM Top Disc +Y+Z	-57.13	24.3	-32.83	0.0374	-1.228
7212	MLI SVM Top Disc +Y+Z	-56.68	24.3	-32.38	0.0312	-1.010
7213	MLI SVM Top Disc +Y+Z	-57.01	24.5	-32.51	0.029	-0.943
7214	MLI SVM Top Disc +Y+Z	-56.64	24	-32.64	0.0505	-1.648
7215	MLI SVM Top Disc +Y+Z	-57.00	24.1	-32.90	0.0514	-1.691
7216	MLI SVM Top Disc +Y+Z	-21.60	16.3	-5.30	0.0578	-0.306
7217	MLI SVM Top Disc +Y+Z	-49.62	18.3	-31.32	0.0968	-3.032



Controlled Distribution



REFERENCE : H-P-RP-AI-0040

DATE : 29/SEP/06

ISSUE : 06

Page : 149/405

PLANCK ITP-150-P						
WORST HOT CASE: EOL Rotx=-10						
NODE	LABEL	Temperature [°C]	UFP [°C]	T+UFP [°C]	Area [m²]	T+UFP * Area
7219	MLI SVM Top Disc +Y+Z	-5.10	24(**)	18.90	0.0573	1.083
7221	MLI SVM Top Disc +Y+Z	-7.00	24(**)	17.00	0.0573	0.974
7223	MLI SVM Top Disc +Y+Z	-23.30	17.5	-5.80	0.0968	-0.561
7225	MLI SVM Top Disc +Y+Z	5.32	20.6	25.92	0.0514	1.332
7226	MLI SVM Top Disc +Y+Z	9.68	21.8	31.48	0.031	0.976
7227	MLI SVM Top Disc +Y+Z	3.10	18.2	21.30	0.0374	0.797
7228	MLI SVM Top Disc +Y+Z	-53.52	24.2	-29.32	0.0334	-0.979
7229	MLI SVM Top Disc +Y+Z	-45.66	20.4	-25.26	0.0541	-1.367
7230	MLI SVM Top Disc +Y+Z	-55.36	23.7	-31.66	0.044	-1.393
7231	MLI SVM Top Disc +Y+Z	-54.98	23.9	-31.08	0.0282	-0.876
7232	MLI SVM Top Disc +Y+Z	-56.07	24.8	-31.27	0.0304	-0.951
7233	MLI SVM Top Disc +Y+Z	-56.21	24.5	-31.71	0.0387	-1.227
7234	MLI SVM Top Disc +Y+Z	-55.34	24.6	-30.74	0.0385	-1.183
7235	MLI SVM Top Disc +Y+Z	-56.28	24.7	-31.58	0.0414	-1.307
7236	MLI SVM Top Disc +Y+Z	-53.60	24.8	-28.80	0.0475	-1.368
7237	MLI SVM Top Disc +Y+Z	-54.92	24.7	-30.22	0.0805	-2.433
7238	MLI SVM Top Disc +Y+Z	-51.45	24.9	-26.55	0.041	-1.089
7239	MLI SVM Top Disc +Y+Z	-53.07	25.3	-27.77	0.0481	-1.336
7245	SVM Top Disc MLI	-62.06	22.9	-39.16	1.7492	-68.499
		AVG T		AVG T+UFP	Σ Area	Σ T+UFP*Area
		-45.42		-22.03	3.3801	-102.1
		Weighed avg T: °C	-53.14	Weighed avg T+UFP: °C		-30.20

(**) values assumed

Table 7.2-2 PLANCK – ITP-150-P Temperature Results

PLANCK ITP-180-P				
WORST HOT CASE: EOL Rotx=-10				
NODE	LABEL	T [°C]	UFP [°C]	T+UFP [°C]
7521	MLI on BEU	-67.9	24.0	-43.9
7522	MLI on PAU	-68.3	23.3	-45.0
	Max temperature	-67.9		-43.9

Table 7.2-3 PLANCK – ITP-180-P Temperature Results

Note: 24°C of UFP on BEU MLI is assumed.



Controlled Distribution

PLANCK ITP-200-P				
WORST HOT CASE: EOL Rotx=-10				
NODE	LABEL	T [°C]	UFP [°C]	T+UFP [°C]
8101	MLI Solar Array vs. sate	-3.3	27.7	24.4
8102	MLI Solar Array vs. sate	-6.8	27.7	20.9
8103	MLI Solar Array vs. sate	-10.1	27.7	17.6
8104	MLI Solar Array vs. sate	2.2	26.9	29.1
8105	MLI Solar Array vs. sate	-4.5	26.9	22.4
8106	MLI Solar Array vs. sate	-2.4	26.9	24.5
8107	MLI Solar Array vs. sate	1.4	27.2	28.6
8108	MLI Solar Array vs. sate	-2.5	27.2	24.7
8109	MLI Solar Array vs. sate	-3.9	27.2	23.3
8110	MLI Solar Array vs. sate	-3.2	27.3	24.1
8111	MLI Solar Array vs. sate	-7.9	27.3	19.4
8112	MLI Solar Array vs. sate	-5.5	27.3	21.8
	Max temperature	2.2		29.1

Table 7.2-4 PLANCK – ITP-200-P Temperature Results

Controlled Distribution

PLANCK ITP-210-P				
WORST HOT CASE: EOL Rotx=-10				
NODE	LABEL	T [°C]	UFP [°C]	T+UFP [°C]
10021	I/F PLM/SVM strut1	20.4	7.9	28.3
10022	I/F PLM/SVM strut2	21.3	7.9	29.2
10023	I/F PLM/SVM strut3	16.0	8.8	24.8
10024	I/F PLM/SVM strut4	15.9	8.8	24.7
10025	I/F PLM/SVM strut5	20.2	7.9	28.1
10026	I/F PLM/SVM strut6	20.7	7.9	28.6
	Max temperature	21.3		29.2

Table 7.2-5 PLANCK – ITP-210-P Temperature Results

PLANCK ITP-170-P – Temperature considered without uncertainty								
NODES		GR [W/K ⁴]	A1 Heat Flow [W]	A2 Heat Flow [W]	A3 Heat Flow [W]	B1 Heat Flow [W]	B2 Heat Flow [W]	C Heat Flow [W]
GR(B10001	519	3.10E-05	1.099E-02	8.772E-03	1.024E-02	1.234E-02	1.234E-02	8.015E-03
GR(B10001	520	3.73E-05	1.270E-02	9.846E-03	1.208E-02	1.425E-02	1.425E-02	9.094E-03
GR(B10001	521	3.52E-05	1.258E-02	9.723E-03	1.205E-02	1.414E-02	1.414E-02	9.007E-03
GR(B10001	522	8.69E-05	2.982E-02	2.644E-02	2.496E-02	3.336E-02	3.337E-02	2.274E-02
GR(B10001	561	6.23E-05	1.641E-02	1.324E-02	1.571E-02	1.824E-02	1.824E-02	1.232E-02
GR(B10001	562	9.20E-05	2.716E-02	2.161E-02	2.591E-02	3.029E-02	3.030E-02	2.004E-02
GR(B10001	563	9.06E-05	2.674E-02	2.129E-02	2.550E-02	2.983E-02	2.983E-02	1.973E-02
GR(B10001	564	6.09E-05	1.604E-02	1.295E-02	1.527E-02	1.782E-02	1.782E-02	1.202E-02
GR(B10001	566	1.20E-04	3.155E-02	2.547E-02	3.021E-02	3.507E-02	3.507E-02	2.371E-02
GR(B10001	567	1.29E-04	3.751E-02	2.989E-02	3.579E-02	4.181E-02	4.182E-02	2.773E-02
GR(B10001	568	1.36E-04	3.955E-02	3.152E-02	3.771E-02	4.408E-02	4.409E-02	2.923E-02
GR(B10001	569	1.17E-04	3.075E-02	2.484E-02	2.927E-02	3.415E-02	3.416E-02	2.306E-02
GR(B10001	571	1.46E-04	3.776E-02	3.048E-02	3.616E-02	4.193E-02	4.194E-02	2.838E-02
GR(B10001	572	1.53E-04	4.208E-02	3.372E-02	4.020E-02	4.680E-02	4.681E-02	3.132E-02
GR(B10001	573	1.59E-04	4.373E-02	3.505E-02	4.172E-02	4.863E-02	4.863E-02	3.254E-02
GR(B10001	574	1.51E-04	3.904E-02	3.155E-02	3.718E-02	4.333E-02	4.334E-02	2.930E-02
GR(B10001	581	3.49E-05	1.071E-02	9.551E-03	9.175E-03	1.194E-02	1.194E-02	8.443E-03
GR(B10001	582	3.43E-05	1.044E-02	9.315E-03	8.958E-03	1.163E-02	1.163E-02	8.255E-03
GR(B10001	583	3.17E-05	9.502E-03	8.487E-03	8.168E-03	1.058E-02	1.058E-02	7.555E-03
GR(B10001	584	3.77E-05	1.079E-02	9.653E-03	9.276E-03	1.199E-02	1.200E-02	8.569E-03
GR(B10001	585	3.65E-05	1.031E-02	9.238E-03	8.887E-03	1.145E-02	1.145E-02	8.227E-03

Controlled Distribution



REFERENCE : H-P-RP-AI-0040

DATE : 29/SEP/06

ISSUE : 06

Page : 152/405

PLANCK ITP-170-P – Temperature considered without uncertainty							
NODES	GR [W/K ⁴]	A1	A2	A3	B1	B2	C
		Heat Flow [W]	Heat Flow [W]	Heat Flow [W]	Heat Flow [W]	Heat Flow [W]	Heat Flow [W]
GR(B10001 586	3.44E-05	9.584E-03	8.592E-03	8.274E-03	1.063E-02	1.063E-02	7.683E-03
GR(B10001 587	4.84E-05	1.340E-02	1.200E-02	1.153E-02	1.486E-02	1.487E-02	1.067E-02
GR(B10001 588	4.76E-05	1.298E-02	1.165E-02	1.121E-02	1.439E-02	1.439E-02	1.039E-02
GR(B10001 589	4.47E-05	1.204E-02	1.082E-02	1.042E-02	1.334E-02	1.334E-02	9.685E-03
GR(B10001 590	2.25E-05	6.415E-03	5.750E-03	5.546E-03	7.128E-03	7.130E-03	5.195E-03
GR(B10001 591	1.89E-05	5.351E-03	4.799E-03	4.632E-03	5.944E-03	5.945E-03	4.345E-03
GR(B10001 592	2.72E-05	7.437E-03	6.675E-03	6.432E-03	8.245E-03	8.247E-03	6.003E-03
GR(B10001 593	2.03E-05	5.464E-03	4.911E-03	4.738E-03	6.050E-03	6.052E-03	4.436E-03
GR(B10001 594	3.47E-05	9.260E-03	8.318E-03	8.015E-03	1.026E-02	1.026E-02	7.472E-03
GR(B10001 595	2.26E-05	5.931E-03	5.337E-03	5.148E-03	6.559E-03	6.561E-03	4.815E-03
GR(B10004 519	4.36E-05	1.616E-02	1.305E-02	1.512E-02	1.806E-02	1.807E-02	1.198E-02
GR(B10004 520	4.69E-05	1.674E-02	1.315E-02	1.596E-02	1.868E-02	1.868E-02	1.220E-02
GR(B10004 521	3.68E-05	1.375E-02	1.076E-02	1.319E-02	1.538E-02	1.538E-02	1.002E-02
GR(B10004 522	1.54E-04	5.536E-02	4.936E-02	4.674E-02	6.163E-02	6.165E-02	4.280E-02
GR(B10004 561	1.11E-04	3.105E-02	2.540E-02	2.980E-02	3.431E-02	3.431E-02	2.376E-02
GR(B10004 562	1.48E-04	4.610E-02	3.718E-02	4.409E-02	5.114E-02	5.115E-02	3.465E-02
GR(B10004 563	1.48E-04	4.609E-02	3.718E-02	4.407E-02	5.114E-02	5.115E-02	3.465E-02
GR(B10004 564	1.11E-04	3.104E-02	2.541E-02	2.964E-02	3.428E-02	3.429E-02	2.372E-02
GR(B10004 566	1.86E-04	5.193E-02	4.252E-02	4.986E-02	5.739E-02	5.740E-02	3.978E-02
GR(B10004 567	1.94E-04	5.958E-02	4.812E-02	5.699E-02	6.605E-02	6.606E-02	4.487E-02
GR(B10004 568	1.93E-04	5.927E-02	4.788E-02	5.667E-02	6.570E-02	6.572E-02	4.463E-02
GR(B10004 569	1.90E-04	5.304E-02	4.344E-02	5.063E-02	5.856E-02	5.857E-02	4.054E-02
GR(B10004 571	1.81E-04	4.976E-02	4.074E-02	4.778E-02	5.494E-02	5.495E-02	3.813E-02
GR(B10004 572	1.76E-04	5.127E-02	4.166E-02	4.912E-02	5.670E-02	5.671E-02	3.890E-02
GR(B10004 573	1.83E-04	5.331E-02	4.333E-02	5.100E-02	5.895E-02	5.896E-02	4.044E-02
GR(B10004 574	1.82E-04	5.002E-02	4.100E-02	4.778E-02	5.519E-02	5.520E-02	3.828E-02
GR(B10004 581	7.81E-05	2.524E-02	2.265E-02	2.181E-02	2.800E-02	2.800E-02	2.017E-02
GR(B10004 582	7.75E-05	2.485E-02	2.231E-02	2.150E-02	2.754E-02	2.755E-02	1.991E-02
GR(B10004 583	7.85E-05	2.481E-02	2.230E-02	2.151E-02	2.748E-02	2.748E-02	1.999E-02
GR(B10004 584	7.45E-05	2.254E-02	2.029E-02	1.955E-02	2.491E-02	2.492E-02	1.815E-02
GR(B10004 585	7.33E-05	2.191E-02	1.975E-02	1.904E-02	2.418E-02	2.419E-02	1.772E-02
GR(B10004 586	7.51E-05	2.215E-02	1.998E-02	1.929E-02	2.443E-02	2.444E-02	1.800E-02
GR(B10004 587	6.84E-05	2.005E-02	1.807E-02	1.741E-02	2.212E-02	2.213E-02	1.619E-02
GR(B10004 588	7.01E-05	2.026E-02	1.830E-02	1.765E-02	2.233E-02	2.234E-02	1.645E-02
GR(B10004 589	7.14E-05	2.040E-02	1.844E-02	1.780E-02	2.247E-02	2.248E-02	1.663E-02
GR(B10004 590	1.04E-04	3.135E-02	2.827E-02	2.733E-02	3.464E-02	3.465E-02	2.571E-02
GR(B10004 591	9.83E-05	2.944E-02	2.656E-02	2.569E-02	3.252E-02	3.253E-02	2.420E-02
GR(B10004 592	9.83E-05	2.848E-02	2.572E-02	2.485E-02	3.140E-02	3.141E-02	2.330E-02



Controlled Distribution



REFERENCE : H-P-RP-AI-0040

DATE : 29/SEP/06

ISSUE : 06

Page : 153/405

PLANCK ITP-170-P – Temperature considered without uncertainty								
NODES	GR [W/K ⁴]	A1	A2	A3	B1	B2	C	
		Heat Flow [W]	Heat Flow [W]	Heat Flow [W]	Heat Flow [W]	Heat Flow [W]	Heat Flow [W]	
GR(B10004	593	9.14E-05	2.609E-02	2.360E-02	2.282E-02	2.873E-02	2.874E-02	2.146E-02
GR(B10004	594	9.30E-05	2.633E-02	2.381E-02	2.300E-02	2.900E-02	2.901E-02	2.154E-02
GR(B10004	595	8.95E-05	2.495E-02	2.259E-02	2.185E-02	2.743E-02	2.744E-02	2.053E-02
GR(B10005	519	9.02E-05	3.317E-02	2.673E-02	3.101E-02	3.710E-02	3.711E-02	2.452E-02
GR(B10005	520	9.64E-05	3.412E-02	2.673E-02	3.252E-02	3.811E-02	3.811E-02	2.479E-02
GR(B10005	521	8.21E-05	3.044E-02	2.377E-02	2.919E-02	3.407E-02	3.408E-02	2.210E-02
GR(B10005	522	1.76E-04	6.275E-02	5.590E-02	5.290E-02	6.992E-02	6.994E-02	4.840E-02
GR(B10005	561	3.08E-06	8.524E-04	6.957E-04	8.179E-04	9.429E-04	9.430E-04	6.503E-04
GR(B10005	562	3.19E-06	9.842E-04	7.919E-04	9.409E-04	1.093E-03	1.093E-03	7.375E-04
GR(B10005	563	2.97E-06	9.162E-04	7.374E-04	8.756E-04	1.017E-03	1.018E-03	6.865E-04
GR(B10005	564	2.47E-06	6.835E-04	5.582E-04	6.524E-04	7.556E-04	7.557E-04	5.204E-04
GR(B10005	566	5.49E-06	1.517E-03	1.239E-03	1.455E-03	1.678E-03	1.678E-03	1.158E-03
GR(B10005	567	4.86E-06	1.478E-03	1.191E-03	1.413E-03	1.640E-03	1.640E-03	1.110E-03
GR(B10005	568	4.27E-06	1.299E-03	1.047E-03	1.241E-03	1.441E-03	1.441E-03	9.748E-04
GR(B10005	569	4.41E-06	1.218E-03	9.952E-04	1.162E-03	1.346E-03	1.346E-03	9.279E-04
GR(B10005	571	6.02E-06	1.637E-03	1.337E-03	1.571E-03	1.809E-03	1.810E-03	1.250E-03
GR(B10005	572	5.50E-06	1.586E-03	1.285E-03	1.519E-03	1.756E-03	1.756E-03	1.199E-03
GR(B10005	573	5.63E-06	1.623E-03	1.316E-03	1.552E-03	1.797E-03	1.797E-03	1.227E-03
GR(B10005	574	3.94E-06	1.071E-03	8.758E-04	1.023E-03	1.183E-03	1.183E-03	8.171E-04
GR(B10005	581	7.81E-06	2.501E-03	2.242E-03	2.157E-03	2.776E-03	2.777E-03	1.994E-03
GR(B10005	582	8.38E-06	2.663E-03	2.388E-03	2.300E-03	2.953E-03	2.954E-03	2.129E-03
GR(B10005	583	1.05E-05	3.288E-03	2.951E-03	2.846E-03	3.644E-03	3.645E-03	2.643E-03
GR(B10005	584	9.28E-06	2.780E-03	2.500E-03	2.407E-03	3.076E-03	3.077E-03	2.233E-03
GR(B10005	585	8.58E-06	2.539E-03	2.286E-03	2.204E-03	2.806E-03	2.806E-03	2.048E-03
GR(B10005	586	1.05E-05	3.065E-03	2.763E-03	2.666E-03	3.385E-03	3.386E-03	2.485E-03
GR(B10005	587	6.65E-06	1.929E-03	1.737E-03	1.673E-03	2.131E-03	2.131E-03	1.555E-03
GR(B10005	588	7.98E-06	2.283E-03	2.059E-03	1.986E-03	2.519E-03	2.519E-03	1.849E-03
GR(B10005	589	1.12E-05	3.167E-03	2.860E-03	2.760E-03	3.492E-03	3.493E-03	2.576E-03
GR(B10005	590	6.66E-05	1.988E-02	1.791E-02	1.731E-02	2.199E-02	2.199E-02	1.627E-02
GR(B10005	591	7.16E-05	2.123E-02	1.914E-02	1.850E-02	2.347E-02	2.348E-02	1.742E-02
GR(B10005	592	6.75E-05	1.936E-02	1.746E-02	1.686E-02	2.136E-02	2.137E-02	1.580E-02
GR(B10005	593	7.67E-05	2.167E-02	1.958E-02	1.893E-02	2.388E-02	2.389E-02	1.779E-02
GR(B10005	594	7.24E-05	2.029E-02	1.832E-02	1.769E-02	2.236E-02	2.237E-02	1.656E-02
GR(B10005	595	8.56E-05	2.361E-02	2.136E-02	2.064E-02	2.599E-02	2.599E-02	1.938E-02
GR(B10010	519	1.14E-04	3.773E-02	2.958E-02	3.500E-02	4.270E-02	4.271E-02	2.680E-02
GR(B10010	520	3.16E-05	1.002E-02	7.601E-03	9.497E-03	1.133E-02	1.133E-02	6.964E-03
GR(B10010	521	2.68E-05	8.952E-03	6.774E-03	8.543E-03	1.014E-02	1.014E-02	6.229E-03



Controlled Distribution



REFERENCE : H-P-RP-AI-0040

DATE : 29/SEP/06

ISSUE : 06

Page : 154/405

PLANCK ITP-170-P – Temperature considered without uncertainty								
NODES	GR [W/K ⁴]	A1	A2	A3	B1	B2	C	
		Heat Flow [W]	Heat Flow [W]	Heat Flow [W]	Heat Flow [W]	Heat Flow [W]	Heat Flow [W]	
GR(B10010 522	4.80E-04	1.535E-01	1.348E-01	1.266E-01	1.730E-01	1.731E-01	1.143E-01	
GR(B10010 561	7.75E-06	1.860E-03	1.465E-03	1.773E-03	2.087E-03	2.088E-03	1.351E-03	
GR(B10010 562	2.06E-05	5.598E-03	4.356E-03	5.318E-03	6.299E-03	6.301E-03	4.005E-03	
GR(B10010 563	2.11E-05	5.733E-03	4.463E-03	5.444E-03	6.452E-03	6.453E-03	4.101E-03	
GR(B10010 564	3.55E-05	8.517E-03	6.717E-03	8.070E-03	9.553E-03	9.555E-03	6.173E-03	
GR(B10010 566	1.99E-05	4.765E-03	3.758E-03	4.543E-03	5.349E-03	5.350E-03	3.465E-03	
GR(B10010 567	1.89E-05	5.053E-03	3.937E-03	4.801E-03	5.683E-03	5.684E-03	3.620E-03	
GR(B10010 568	3.29E-05	8.796E-03	6.854E-03	8.352E-03	9.891E-03	9.894E-03	6.301E-03	
GR(B10010 569	6.10E-05	1.460E-02	1.152E-02	1.383E-02	1.638E-02	1.638E-02	1.059E-02	
GR(B10010 571	2.05E-05	4.821E-03	3.799E-03	4.597E-03	5.407E-03	5.408E-03	3.504E-03	
GR(B10010 572	2.17E-05	5.459E-03	4.273E-03	5.193E-03	6.129E-03	6.130E-03	3.934E-03	
GR(B10010 573	4.28E-05	1.077E-02	8.432E-03	1.023E-02	1.209E-02	1.209E-02	7.756E-03	
GR(B10010 574	7.95E-05	1.869E-02	1.475E-02	1.771E-02	2.095E-02	2.095E-02	1.356E-02	
GR(B10010 581	9.71E-05	2.753E-02	2.430E-02	2.325E-02	3.095E-02	3.096E-02	2.121E-02	
GR(B10010 582	6.15E-05	1.728E-02	1.526E-02	1.462E-02	1.941E-02	1.942E-02	1.336E-02	
GR(B10010 583	4.75E-05	1.312E-02	1.160E-02	1.113E-02	1.474E-02	1.474E-02	1.021E-02	
GR(B10010 584	9.33E-05	2.452E-02	2.170E-02	2.077E-02	2.749E-02	2.750E-02	1.902E-02	
GR(B10010 585	6.45E-05	1.671E-02	1.481E-02	1.419E-02	1.872E-02	1.872E-02	1.303E-02	
GR(B10010 586	4.72E-05	1.204E-02	1.068E-02	1.025E-02	1.348E-02	1.348E-02	9.436E-03	
GR(B10010 587	1.11E-04	2.812E-02	2.492E-02	2.384E-02	3.149E-02	3.149E-02	2.187E-02	
GR(B10010 588	6.95E-05	1.733E-02	1.538E-02	1.474E-02	1.938E-02	1.938E-02	1.355E-02	
GR(B10010 589	4.21E-05	1.036E-02	9.200E-03	8.825E-03	1.158E-02	1.158E-02	8.134E-03	
GR(B10010 590	1.15E-04	3.009E-02	2.669E-02	2.565E-02	3.373E-02	3.375E-02	2.386E-02	
GR(B10010 591	1.38E-04	3.584E-02	3.181E-02	3.058E-02	4.016E-02	4.018E-02	2.849E-02	
GR(B10010 592	1.09E-04	2.725E-02	2.419E-02	2.322E-02	3.049E-02	3.049E-02	2.150E-02	
GR(B10010 593	1.31E-04	3.219E-02	2.862E-02	2.751E-02	3.597E-02	3.599E-02	2.556E-02	
GR(B10010 594	1.19E-04	2.897E-02	2.574E-02	2.470E-02	3.238E-02	3.239E-02	2.283E-02	
GR(B10010 595	1.31E-04	3.131E-02	2.786E-02	2.677E-02	3.495E-02	3.496E-02	2.484E-02	
GR(B10011 519	3.94E-05	1.408E-02	1.126E-02	1.313E-02	1.579E-02	1.580E-02	1.030E-02	
GR(B10011 520	6.44E-05	2.211E-02	1.718E-02	2.105E-02	2.478E-02	2.478E-02	1.588E-02	
GR(B10011 521	6.70E-05	2.414E-02	1.870E-02	2.312E-02	2.710E-02	2.710E-02	1.733E-02	
GR(B10011 522	8.52E-05	2.948E-02	2.616E-02	2.471E-02	3.295E-02	3.296E-02	2.253E-02	
GR(B10011 561	3.59E-05	9.558E-03	7.731E-03	9.155E-03	1.061E-02	1.061E-02	7.201E-03	
GR(B10011 562	2.36E-05	7.033E-03	5.610E-03	6.712E-03	7.836E-03	7.839E-03	5.208E-03	
GR(B10011 563	1.94E-05	5.780E-03	4.613E-03	5.515E-03	6.442E-03	6.443E-03	4.280E-03	
GR(B10011 564	1.02E-05	2.715E-03	2.198E-03	2.587E-03	3.013E-03	3.013E-03	2.042E-03	
GR(B10011 566	7.22E-05	1.918E-02	1.553E-02	1.838E-02	2.130E-02	2.131E-02	1.447E-02	
GR(B10011 567	3.87E-05	1.136E-02	9.077E-03	1.085E-02	1.265E-02	1.266E-02	8.429E-03	



Controlled Distribution



REFERENCE : H-P-RP-AI-0040

DATE : 29/SEP/06

ISSUE : 06

Page : 155/405

PLANCK ITP-170-P – Temperature considered without uncertainty							
NODES	GR [W/K ⁴]	A1	A2	A3	B1	B2	C
		Heat Flow [W]	Heat Flow [W]	Heat Flow [W]	Heat Flow [W]	Heat Flow [W]	Heat Flow [W]
GR(B10011 568	2.59E-05	7.604E-03	6.076E-03	7.255E-03	8.467E-03	8.470E-03	5.640E-03
GR(B10011 569	1.24E-05	3.294E-03	2.668E-03	3.137E-03	3.655E-03	3.655E-03	2.479E-03
GR(B10011 571	1.08E-04	2.824E-02	2.285E-02	2.705E-02	3.132E-02	3.133E-02	2.129E-02
GR(B10011 572	3.65E-05	1.014E-02	8.147E-03	9.694E-03	1.127E-02	1.127E-02	7.576E-03
GR(B10011 573	2.18E-05	6.057E-03	4.867E-03	5.781E-03	6.729E-03	6.730E-03	4.523E-03
GR(B10011 574	1.87E-05	4.887E-03	3.960E-03	4.657E-03	5.419E-03	5.420E-03	3.681E-03
GR(B10011 581	2.19E-06	6.784E-04	6.055E-04	5.819E-04	7.555E-04	7.557E-04	5.360E-04
GR(B10011 582	1.36E-06	4.178E-04	3.732E-04	3.590E-04	4.650E-04	4.652E-04	3.311E-04
GR(B10011 583	1.71E-06	5.174E-04	4.627E-04	4.455E-04	5.755E-04	5.756E-04	4.124E-04
GR(B10011 584	2.06E-06	5.955E-04	5.333E-04	5.127E-04	6.611E-04	6.613E-04	4.741E-04
GR(B10011 585	1.10E-06	3.139E-04	2.815E-04	2.709E-04	3.481E-04	3.482E-04	2.510E-04
GR(B10011 586	1.72E-06	4.841E-04	4.344E-04	4.186E-04	5.364E-04	5.365E-04	3.890E-04
GR(B10011 587	1.04E-06	2.908E-04	2.608E-04	2.507E-04	3.223E-04	3.224E-04	2.322E-04
GR(B10011 588	1.93E-06	5.318E-04	4.777E-04	4.599E-04	5.888E-04	5.889E-04	4.269E-04
GR(B10011 589	1.77E-06	4.819E-04	4.333E-04	4.175E-04	5.332E-04	5.334E-04	3.885E-04
GR(B10011 590	8.45E-06	2.433E-03	2.183E-03	2.107E-03	2.701E-03	2.702E-03	1.975E-03
GR(B10011 591	4.61E-06	1.318E-03	1.184E-03	1.143E-03	1.463E-03	1.463E-03	1.073E-03
GR(B10011 592	5.91E-06	1.632E-03	1.467E-03	1.414E-03	1.808E-03	1.809E-03	1.321E-03
GR(B10011 593	4.11E-06	1.118E-03	1.006E-03	9.709E-04	1.237E-03	1.237E-03	9.098E-04
GR(B10011 594	6.39E-06	1.723E-03	1.550E-03	1.494E-03	1.907E-03	1.907E-03	1.394E-03
GR(B10011 595	5.52E-06	1.464E-03	1.319E-03	1.273E-03	1.618E-03	1.618E-03	1.192E-03
GR(B10012 519	5.04E-05	1.831E-02	1.471E-02	1.710E-02	2.051E-02	2.051E-02	1.348E-02
GR(B10012 520	7.49E-05	2.617E-02	2.044E-02	2.493E-02	2.928E-02	2.928E-02	1.893E-02
GR(B10012 521	3.87E-05	1.418E-02	1.103E-02	1.359E-02	1.589E-02	1.589E-02	1.025E-02
GR(B10012 522	8.28E-05	2.915E-02	2.593E-02	2.452E-02	3.253E-02	3.254E-02	2.240E-02
GR(B10012 561	3.46E-06	9.423E-04	7.662E-04	9.034E-04	1.044E-03	1.044E-03	7.151E-04
GR(B10012 562	1.84E-06	5.595E-04	4.486E-04	5.345E-04	6.222E-04	6.224E-04	4.172E-04
GR(B10012 563	3.12E-06	9.486E-04	7.608E-04	9.060E-04	1.055E-03	1.055E-03	7.074E-04
GR(B10012 564	1.37E-06	3.730E-04	3.035E-04	3.558E-04	4.130E-04	4.131E-04	2.826E-04
GR(B10012 566	6.89E-06	1.873E-03	1.524E-03	1.796E-03	2.075E-03	2.075E-03	1.423E-03
GR(B10012 567	3.13E-06	9.381E-04	7.532E-04	8.964E-04	1.042E-03	1.043E-03	7.008E-04
GR(B10012 568	2.21E-06	6.623E-04	5.319E-04	6.325E-04	7.359E-04	7.362E-04	4.947E-04
GR(B10012 569	2.89E-06	7.854E-04	6.393E-04	7.488E-04	8.694E-04	8.695E-04	5.953E-04
GR(B10012 571	7.37E-06	1.972E-03	1.604E-03	1.891E-03	2.183E-03	2.183E-03	1.498E-03
GR(B10012 572	5.52E-06	1.567E-03	1.266E-03	1.500E-03	1.738E-03	1.738E-03	1.179E-03
GR(B10012 573	4.37E-06	1.241E-03	1.002E-03	1.186E-03	1.375E-03	1.376E-03	9.333E-04
GR(B10012 574	3.50E-06	9.361E-04	7.625E-04	8.930E-04	1.036E-03	1.036E-03	7.103E-04
GR(B10012 581	1.56E-06	4.927E-04	4.408E-04	4.240E-04	5.477E-04	5.478E-04	3.913E-04



Controlled Distribution



REFERENCE : H-P-RP-AI-0040

DATE : 29/SEP/06

ISSUE : 06

Page : 156/405

PLANCK ITP-170-P – Temperature considered without uncertainty							
NODES	GR [W/K ⁴]	A1 Heat Flow [W]	A2 Heat Flow [W]	A3 Heat Flow [W]	B1 Heat Flow [W]	B2 Heat Flow [W]	C Heat Flow [W]
GR(B10012 582	8.13E-07	2.547E-04	2.280E-04	2.196E-04	2.829E-04	2.830E-04	2.029E-04
GR(B10012 583	1.56E-06	4.815E-04	4.316E-04	4.159E-04	5.345E-04	5.346E-04	3.857E-04
GR(B10012 584	7.48E-07	2.208E-04	1.982E-04	1.907E-04	2.446E-04	2.447E-04	1.767E-04
GR(B10012 585	6.10E-07	1.778E-04	1.598E-04	1.540E-04	1.968E-04	1.968E-04	1.429E-04
GR(B10012 586	1.25E-06	3.594E-04	3.233E-04	3.118E-04	3.975E-04	3.975E-04	2.903E-04
GR(B10012 587	1.19E-06	3.399E-04	3.056E-04	2.941E-04	3.761E-04	3.761E-04	2.729E-04
GR(B10012 588	7.74E-07	2.180E-04	1.963E-04	1.891E-04	2.409E-04	2.409E-04	1.759E-04
GR(B10012 589	1.14E-06	3.173E-04	2.860E-04	2.758E-04	3.504E-04	3.505E-04	2.572E-04
GR(B10012 590	9.95E-06	2.926E-03	2.631E-03	2.541E-03	3.241E-03	3.242E-03	2.386E-03
GR(B10012 591	4.46E-06	1.303E-03	1.172E-03	1.133E-03	1.442E-03	1.443E-03	1.065E-03
GR(B10012 592	5.45E-06	1.539E-03	1.386E-03	1.337E-03	1.701E-03	1.701E-03	1.251E-03
GR(B10012 593	4.69E-06	1.304E-03	1.176E-03	1.137E-03	1.440E-03	1.440E-03	1.067E-03
GR(B10012 594	4.62E-06	1.274E-03	1.149E-03	1.108E-03	1.407E-03	1.407E-03	1.036E-03
GR(B10012 595	4.17E-06	1.131E-03	1.022E-03	9.870E-04	1.247E-03	1.248E-03	9.256E-04
Total I/F fluxes [W]		2.963	2.504	2.688	3.297	3.298	2.272

Table 7.2-6 PLANCK –ITP-170-P Flux Results

PLANCK ITP-170-P – Temperature considered with uncertainty							
NODES	GR [W/K ⁴]	A1 Heat Flow [W]	A2 Heat Flow [W]	A3 Heat Flow [W]	B1 Heat Flow [W]	B2 Heat Flow [W]	C Heat Flow [W]
GR(B10001 519	3.10E-05	9.539E-03	7.535E-03	8.865E-03	1.407E-02	1.407E-02	6.853E-03
GR(B10001 520	3.73E-05	1.099E-02	8.414E-03	1.043E-02	1.629E-02	1.629E-02	7.738E-03
GR(B10001 521	3.52E-05	1.093E-02	8.342E-03	1.044E-02	1.611E-02	1.611E-02	7.698E-03
GR(B10001 522	8.69E-05	2.610E-02	2.302E-02	2.168E-02	3.776E-02	3.777E-02	1.966E-02
GR(B10001 561	6.23E-05	1.400E-02	1.116E-02	1.337E-02	2.112E-02	2.112E-02	1.034E-02
GR(B10001 562	9.20E-05	2.334E-02	1.835E-02	2.221E-02	3.484E-02	3.485E-02	1.694E-02
GR(B10001 563	9.06E-05	2.298E-02	1.807E-02	2.186E-02	3.431E-02	3.431E-02	1.668E-02
GR(B10001 564	6.09E-05	1.368E-02	1.091E-02	1.299E-02	2.063E-02	2.063E-02	1.008E-02
GR(B10001 566	1.20E-04	2.691E-02	2.146E-02	2.570E-02	4.060E-02	4.061E-02	1.989E-02
GR(B10001 567	1.29E-04	3.221E-02	2.537E-02	3.067E-02	4.813E-02	4.814E-02	2.343E-02
GR(B10001 568	1.36E-04	3.396E-02	2.675E-02	3.231E-02	5.073E-02	5.075E-02	2.470E-02
GR(B10001 569	1.17E-04	2.623E-02	2.093E-02	2.490E-02	3.955E-02	3.955E-02	1.934E-02
GR(B10001 571	1.46E-04	3.218E-02	2.566E-02	3.074E-02	4.859E-02	4.860E-02	2.378E-02
GR(B10001 572	1.53E-04	3.603E-02	2.853E-02	3.435E-02	5.400E-02	5.401E-02	2.639E-02
GR(B10001 573	1.59E-04	3.745E-02	2.966E-02	3.564E-02	5.611E-02	5.612E-02	2.741E-02



Controlled Distribution



REFERENCE : H-P-RP-AI-0040

DATE : 29/SEP/06

ISSUE : 06

Page : 157/405

PLANCK ITP-170-P – Temperature considered with uncertainty							
NODES	GR [W/K ⁴]	A1	A2	A3	B1	B2	C
		Heat Flow [W]	Heat Flow [W]	Heat Flow [W]	Heat Flow [W]	Heat Flow [W]	Heat Flow [W]
GR(B10001 574	1.51E-04	3.327E-02	2.656E-02	3.160E-02	5.021E-02	5.022E-02	2.455E-02
GR(B10001 581	3.49E-05	9.361E-03	8.304E-03	7.962E-03	1.353E-02	1.354E-02	7.297E-03
GR(B10001 582	3.43E-05	9.120E-03	8.096E-03	7.771E-03	1.319E-02	1.319E-02	7.133E-03
GR(B10001 583	3.17E-05	8.295E-03	7.371E-03	7.082E-03	1.200E-02	1.200E-02	6.525E-03
GR(B10001 584	3.77E-05	9.418E-03	8.381E-03	8.038E-03	1.361E-02	1.361E-02	7.397E-03
GR(B10001 585	3.65E-05	8.994E-03	8.016E-03	7.697E-03	1.300E-02	1.300E-02	7.098E-03
GR(B10001 586	3.44E-05	8.353E-03	7.451E-03	7.162E-03	1.208E-02	1.208E-02	6.626E-03
GR(B10001 587	4.84E-05	1.169E-02	1.042E-02	9.995E-03	1.687E-02	1.687E-02	9.212E-03
GR(B10001 588	4.76E-05	1.132E-02	1.011E-02	9.709E-03	1.634E-02	1.634E-02	8.971E-03
GR(B10001 589	4.47E-05	1.050E-02	9.382E-03	9.020E-03	1.515E-02	1.516E-02	8.354E-03
GR(B10001 590	2.25E-05	5.597E-03	4.992E-03	4.807E-03	8.090E-03	8.093E-03	4.488E-03
GR(B10001 591	1.89E-05	4.683E-03	4.180E-03	4.027E-03	6.728E-03	6.730E-03	3.766E-03
GR(B10001 592	2.72E-05	6.487E-03	5.793E-03	5.573E-03	9.361E-03	9.362E-03	5.183E-03
GR(B10001 593	2.03E-05	4.771E-03	4.267E-03	4.110E-03	6.863E-03	6.865E-03	3.836E-03
GR(B10001 594	3.47E-05	8.083E-03	7.225E-03	6.949E-03	1.164E-02	1.164E-02	6.455E-03
GR(B10001 595	2.26E-05	5.173E-03	4.632E-03	4.460E-03	7.447E-03	7.450E-03	4.158E-03
GR(B10004 519	4.36E-05	1.413E-02	1.131E-02	1.318E-02	2.049E-02	2.050E-02	1.035E-02
GR(B10004 520	4.69E-05	1.458E-02	1.134E-02	1.388E-02	2.125E-02	2.125E-02	1.049E-02
GR(B10004 521	3.68E-05	1.203E-02	9.322E-03	1.152E-02	1.744E-02	1.745E-02	8.648E-03
GR(B10004 522	1.54E-04	4.877E-02	4.330E-02	4.092E-02	6.943E-02	6.945E-02	3.735E-02
GR(B10004 561	1.11E-04	2.675E-02	2.169E-02	2.563E-02	3.944E-02	3.944E-02	2.023E-02
GR(B10004 562	1.48E-04	3.996E-02	3.193E-02	3.815E-02	5.846E-02	5.848E-02	2.967E-02
GR(B10004 563	1.48E-04	3.995E-02	3.194E-02	3.813E-02	5.846E-02	5.847E-02	2.967E-02
GR(B10004 564	1.11E-04	2.675E-02	2.170E-02	2.549E-02	3.941E-02	3.942E-02	2.018E-02
GR(B10004 566	1.86E-04	4.474E-02	3.630E-02	4.287E-02	6.597E-02	6.598E-02	3.386E-02
GR(B10004 567	1.94E-04	5.161E-02	4.131E-02	4.928E-02	7.554E-02	7.555E-02	3.840E-02
GR(B10004 568	1.93E-04	5.134E-02	4.110E-02	4.900E-02	7.514E-02	7.516E-02	3.819E-02
GR(B10004 569	1.90E-04	4.569E-02	3.709E-02	4.353E-02	6.732E-02	6.733E-02	3.450E-02
GR(B10004 571	1.81E-04	4.284E-02	3.476E-02	4.106E-02	6.319E-02	6.320E-02	3.243E-02
GR(B10004 572	1.76E-04	4.432E-02	3.568E-02	4.238E-02	6.499E-02	6.499E-02	3.322E-02
GR(B10004 573	1.83E-04	4.608E-02	3.712E-02	4.400E-02	6.756E-02	6.757E-02	3.453E-02
GR(B10004 574	1.82E-04	4.306E-02	3.498E-02	4.105E-02	6.349E-02	6.350E-02	3.256E-02
GR(B10004 581	7.81E-05	2.222E-02	1.986E-02	1.909E-02	3.156E-02	3.157E-02	1.760E-02
GR(B10004 582	7.75E-05	2.187E-02	1.956E-02	1.882E-02	3.106E-02	3.107E-02	1.738E-02
GR(B10004 583	7.85E-05	2.182E-02	1.953E-02	1.882E-02	3.100E-02	3.101E-02	1.744E-02
GR(B10004 584	7.45E-05	1.982E-02	1.778E-02	1.710E-02	2.811E-02	2.812E-02	1.583E-02
GR(B10004 585	7.33E-05	1.926E-02	1.729E-02	1.665E-02	2.730E-02	2.731E-02	1.545E-02
GR(B10004 586	7.51E-05	1.946E-02	1.749E-02	1.686E-02	2.759E-02	2.760E-02	1.569E-02



Controlled Distribution



REFERENCE : H-P-RP-AI-0040

DATE : 29/SEP/06

ISSUE : 06

Page : 158/405

PLANCK ITP-170-P – Temperature considered with uncertainty							
NODES	GR [W/K ⁴]	A1	A2	A3	B1	B2	C
		Heat Flow [W]	Heat Flow [W]	Heat Flow [W]	Heat Flow [W]	Heat Flow [W]	Heat Flow [W]
GR(B10004 587	6.84E-05	1.764E-02	1.584E-02	1.524E-02	2.495E-02	2.496E-02	1.413E-02
GR(B10004 588	7.01E-05	1.782E-02	1.603E-02	1.544E-02	2.520E-02	2.520E-02	1.435E-02
GR(B10004 589	7.14E-05	1.794E-02	1.615E-02	1.557E-02	2.537E-02	2.538E-02	1.451E-02
GR(B10004 590	1.04E-04	2.757E-02	2.477E-02	2.391E-02	3.909E-02	3.910E-02	2.244E-02
GR(B10004 591	9.83E-05	2.596E-02	2.334E-02	2.255E-02	3.659E-02	3.661E-02	2.119E-02
GR(B10004 592	9.83E-05	2.505E-02	2.254E-02	2.174E-02	3.543E-02	3.544E-02	2.033E-02
GR(B10004 593	9.14E-05	2.297E-02	2.070E-02	2.000E-02	3.239E-02	3.240E-02	1.876E-02
GR(B10004 594	9.30E-05	2.318E-02	2.088E-02	2.014E-02	3.270E-02	3.271E-02	1.882E-02
GR(B10004 595	8.95E-05	2.194E-02	1.980E-02	1.912E-02	3.095E-02	3.096E-02	1.793E-02
GR(B10005 519	9.02E-05	2.896E-02	2.313E-02	2.700E-02	4.213E-02	4.214E-02	2.114E-02
GR(B10005 520	9.64E-05	2.969E-02	2.303E-02	2.825E-02	4.339E-02	4.339E-02	2.129E-02
GR(B10005 521	8.21E-05	2.659E-02	2.055E-02	2.545E-02	3.868E-02	3.868E-02	1.905E-02
GR(B10005 522	1.76E-04	5.521E-02	4.897E-02	4.625E-02	7.883E-02	7.885E-02	4.216E-02
GR(B10005 561	3.08E-06	7.331E-04	5.927E-04	7.021E-04	1.085E-03	1.085E-03	5.521E-04
GR(B10005 562	3.19E-06	8.518E-04	6.789E-04	8.127E-04	1.251E-03	1.251E-03	6.301E-04
GR(B10005 563	2.97E-06	7.929E-04	6.322E-04	7.563E-04	1.164E-03	1.165E-03	5.866E-04
GR(B10005 564	2.47E-06	5.878E-04	4.756E-04	5.599E-04	8.696E-04	8.698E-04	4.418E-04
GR(B10005 566	5.49E-06	1.304E-03	1.055E-03	1.249E-03	1.931E-03	1.931E-03	9.831E-04
GR(B10005 567	4.86E-06	1.278E-03	1.020E-03	1.220E-03	1.878E-03	1.878E-03	9.476E-04
GR(B10005 568	4.27E-06	1.123E-03	8.968E-04	1.071E-03	1.650E-03	1.650E-03	8.324E-04
GR(B10005 569	4.41E-06	1.047E-03	8.478E-04	9.973E-04	1.549E-03	1.550E-03	7.878E-04
GR(B10005 571	6.02E-06	1.407E-03	1.138E-03	1.348E-03	2.084E-03	2.084E-03	1.061E-03
GR(B10005 572	5.50E-06	1.369E-03	1.099E-03	1.308E-03	2.015E-03	2.015E-03	1.022E-03
GR(B10005 573	5.63E-06	1.401E-03	1.125E-03	1.337E-03	2.062E-03	2.062E-03	1.046E-03
GR(B10005 574	3.94E-06	9.206E-04	7.456E-04	8.770E-04	1.363E-03	1.363E-03	6.932E-04
GR(B10005 581	7.81E-06	2.199E-03	1.962E-03	1.886E-03	3.133E-03	3.134E-03	1.737E-03
GR(B10005 582	8.38E-06	2.340E-03	2.090E-03	2.010E-03	3.334E-03	3.335E-03	1.854E-03
GR(B10005 583	1.05E-05	2.888E-03	2.582E-03	2.486E-03	4.115E-03	4.116E-03	2.301E-03
GR(B10005 584	9.28E-06	2.442E-03	2.187E-03	2.102E-03	3.474E-03	3.475E-03	1.945E-03
GR(B10005 585	8.58E-06	2.229E-03	1.999E-03	1.924E-03	3.170E-03	3.171E-03	1.783E-03
GR(B10005 586	1.05E-05	2.690E-03	2.414E-03	2.326E-03	3.827E-03	3.828E-03	2.163E-03
GR(B10005 587	6.65E-06	1.695E-03	1.520E-03	1.462E-03	2.406E-03	2.407E-03	1.355E-03
GR(B10005 588	7.98E-06	2.005E-03	1.801E-03	1.734E-03	2.845E-03	2.846E-03	1.610E-03
GR(B10005 589	1.12E-05	2.780E-03	2.500E-03	2.409E-03	3.946E-03	3.947E-03	2.243E-03
GR(B10005 590	6.66E-05	1.746E-02	1.566E-02	1.512E-02	2.484E-02	2.484E-02	1.417E-02
GR(B10005 591	7.16E-05	1.870E-02	1.679E-02	1.621E-02	2.644E-02	2.645E-02	1.522E-02
GR(B10005 592	6.75E-05	1.700E-02	1.528E-02	1.473E-02	2.413E-02	2.413E-02	1.376E-02
GR(B10005 593	7.67E-05	1.905E-02	1.715E-02	1.655E-02	2.695E-02	2.696E-02	1.552E-02



Controlled Distribution



REFERENCE : H-P-RP-AI-0040

DATE : 29/SEP/06

ISSUE : 06

Page : 159/405

PLANCK ITP-170-P – Temperature considered with uncertainty							
NODES	GR [W/K ⁴]	A1 Heat Flow [W]	A2 Heat Flow [W]	A3 Heat Flow [W]	B1 Heat Flow [W]	B2 Heat Flow [W]	C Heat Flow [W]
GR(B10005 594)	7.24E-05	1.783E-02	1.604E-02	1.547E-02	2.524E-02	2.525E-02	1.444E-02
GR(B10005 595)	8.56E-05	2.073E-02	1.869E-02	1.804E-02	2.935E-02	2.936E-02	1.689E-02
GR(B10010 519)	1.14E-04	3.241E-02	2.504E-02	2.993E-02	4.905E-02	4.907E-02	2.253E-02
GR(B10010 520)	3.16E-05	8.570E-03	6.387E-03	8.097E-03	1.306E-02	1.306E-02	5.815E-03
GR(B10010 521)	2.68E-05	7.692E-03	5.723E-03	7.322E-03	1.164E-02	1.164E-02	5.232E-03
GR(B10010 522)	4.80E-04	1.329E-01	1.159E-01	1.085E-01	1.973E-01	1.974E-01	9.733E-02
GR(B10010 561)	7.75E-06	1.560E-03	1.206E-03	1.482E-03	2.446E-03	2.446E-03	1.104E-03
GR(B10010 562)	2.06E-05	4.743E-03	3.626E-03	4.491E-03	7.318E-03	7.320E-03	3.311E-03
GR(B10010 563)	2.11E-05	4.857E-03	3.715E-03	4.597E-03	7.496E-03	7.497E-03	3.391E-03
GR(B10010 564)	3.55E-05	7.142E-03	5.529E-03	6.741E-03	1.119E-02	1.119E-02	5.044E-03
GR(B10010 566)	1.99E-05	3.995E-03	3.093E-03	3.796E-03	6.267E-03	6.268E-03	2.831E-03
GR(B10010 567)	1.89E-05	4.277E-03	3.273E-03	4.050E-03	6.608E-03	6.609E-03	2.990E-03
GR(B10010 568)	3.29E-05	7.444E-03	5.699E-03	7.044E-03	1.150E-02	1.151E-02	5.203E-03
GR(B10010 569)	6.10E-05	1.224E-02	9.482E-03	1.155E-02	1.919E-02	1.919E-02	8.652E-03
GR(B10010 571)	2.05E-05	4.037E-03	3.122E-03	3.836E-03	6.342E-03	6.343E-03	2.858E-03
GR(B10010 572)	2.17E-05	4.602E-03	3.537E-03	4.363E-03	7.150E-03	7.151E-03	3.234E-03
GR(B10010 573)	4.28E-05	9.076E-03	6.980E-03	8.590E-03	1.410E-02	1.410E-02	6.375E-03
GR(B10010 574)	7.95E-05	1.565E-02	1.212E-02	1.477E-02	2.457E-02	2.458E-02	1.106E-02
GR(B10010 581)	9.71E-05	2.377E-02	2.083E-02	1.988E-02	3.538E-02	3.539E-02	1.803E-02
GR(B10010 582)	6.15E-05	1.491E-02	1.307E-02	1.249E-02	2.220E-02	2.221E-02	1.135E-02
GR(B10010 583)	4.75E-05	1.132E-02	9.932E-03	9.498E-03	1.687E-02	1.687E-02	8.664E-03
GR(B10010 584)	9.33E-05	2.112E-02	1.855E-02	1.771E-02	3.150E-02	3.151E-02	1.612E-02
GR(B10010 585)	6.45E-05	1.438E-02	1.265E-02	1.209E-02	2.146E-02	2.147E-02	1.103E-02
GR(B10010 586)	4.72E-05	1.035E-02	9.116E-03	8.721E-03	1.547E-02	1.547E-02	7.985E-03
GR(B10010 587)	1.11E-04	2.421E-02	2.130E-02	2.032E-02	3.608E-02	3.609E-02	1.853E-02
GR(B10010 588)	6.95E-05	1.490E-02	1.313E-02	1.255E-02	2.222E-02	2.223E-02	1.147E-02
GR(B10010 589)	4.21E-05	8.902E-03	7.849E-03	7.508E-03	1.328E-02	1.329E-02	6.881E-03
GR(B10010 590)	1.15E-04	2.591E-02	2.282E-02	2.187E-02	3.865E-02	3.867E-02	2.024E-02
GR(B10010 591)	1.38E-04	3.096E-02	2.728E-02	2.617E-02	4.589E-02	4.590E-02	2.427E-02
GR(B10010 592)	1.09E-04	2.344E-02	2.066E-02	1.978E-02	3.496E-02	3.496E-02	1.821E-02
GR(B10010 593)	1.31E-04	2.772E-02	2.447E-02	2.345E-02	4.122E-02	4.123E-02	2.168E-02
GR(B10010 594)	1.19E-04	2.493E-02	2.199E-02	2.104E-02	3.712E-02	3.713E-02	1.935E-02
GR(B10010 595)	1.31E-04	2.691E-02	2.378E-02	2.278E-02	4.010E-02	4.011E-02	2.103E-02
GR(B10011 519)	3.94E-05	1.223E-02	9.688E-03	1.138E-02	1.799E-02	1.799E-02	8.821E-03
GR(B10011 520)	6.44E-05	1.916E-02	1.471E-02	1.819E-02	2.831E-02	2.831E-02	1.354E-02
GR(B10011 521)	6.70E-05	2.099E-02	1.607E-02	2.006E-02	3.086E-02	3.086E-02	1.484E-02
GR(B10011 522)	8.52E-05	2.583E-02	2.281E-02	2.149E-02	3.726E-02	3.728E-02	1.951E-02



Controlled Distribution



REFERENCE : H-P-RP-AI-0040

DATE : 29/SEP/06

ISSUE : 06

Page : 160/405

PLANCK ITP-170-P – Temperature considered with uncertainty								
NODES		GR [W/K ⁴]	A1 Heat Flow [W]	A2 Heat Flow [W]	A3 Heat Flow [W]	B1 Heat Flow [W]	B2 Heat Flow [W]	C Heat Flow [W]
GR(B10011	561	3.59E-05	8.167E-03	6.531E-03	7.806E-03	1.227E-02	1.227E-02	6.058E-03
GR(B10011	562	2.36E-05	6.053E-03	4.774E-03	5.764E-03	9.004E-03	9.006E-03	4.413E-03
GR(B10011	563	1.94E-05	4.975E-03	3.925E-03	4.736E-03	7.401E-03	7.402E-03	3.627E-03
GR(B10011	564	1.02E-05	2.320E-03	1.857E-03	2.205E-03	3.484E-03	3.484E-03	1.717E-03
GR(B10011	566	7.22E-05	1.639E-02	1.312E-02	1.567E-02	2.463E-02	2.464E-02	1.217E-02
GR(B10011	567	3.87E-05	9.773E-03	7.719E-03	9.309E-03	1.455E-02	1.455E-02	7.138E-03
GR(B10011	568	2.59E-05	6.541E-03	5.167E-03	6.226E-03	9.735E-03	9.737E-03	4.776E-03
GR(B10011	569	1.24E-05	2.815E-03	2.253E-03	2.674E-03	4.226E-03	4.227E-03	2.084E-03
GR(B10011	571	1.08E-04	2.411E-02	1.928E-02	2.304E-02	3.625E-02	3.626E-02	1.789E-02
GR(B10011	572	3.65E-05	8.699E-03	6.908E-03	8.297E-03	1.299E-02	1.299E-02	6.398E-03
GR(B10011	573	2.18E-05	5.195E-03	4.128E-03	4.948E-03	7.754E-03	7.755E-03	3.820E-03
GR(B10011	574	1.87E-05	4.172E-03	3.342E-03	3.966E-03	6.271E-03	6.272E-03	3.093E-03
GR(B10011	581	2.19E-06	5.936E-04	5.272E-04	5.058E-04	8.555E-04	8.557E-04	4.641E-04
GR(B10011	582	1.36E-06	3.655E-04	3.248E-04	3.120E-04	5.267E-04	5.269E-04	2.866E-04
GR(B10011	583	1.71E-06	4.523E-04	4.025E-04	3.868E-04	6.522E-04	6.524E-04	3.568E-04
GR(B10011	584	2.06E-06	5.204E-04	4.638E-04	4.450E-04	7.495E-04	7.497E-04	4.100E-04
GR(B10011	585	1.10E-06	2.742E-04	2.447E-04	2.351E-04	3.948E-04	3.950E-04	2.170E-04
GR(B10011	586	1.72E-06	4.225E-04	3.774E-04	3.630E-04	6.088E-04	6.089E-04	3.362E-04
GR(B10011	587	1.04E-06	2.542E-04	2.268E-04	2.177E-04	3.654E-04	3.654E-04	2.009E-04
GR(B10011	588	1.93E-06	4.646E-04	4.153E-04	3.991E-04	6.678E-04	6.679E-04	3.692E-04
GR(B10011	589	1.77E-06	4.208E-04	3.765E-04	3.621E-04	6.050E-04	6.052E-04	3.358E-04
GR(B10011	590	8.45E-06	2.126E-03	1.898E-03	1.829E-03	3.062E-03	3.063E-03	1.709E-03
GR(B10011	591	4.61E-06	1.155E-03	1.033E-03	9.952E-04	1.654E-03	1.655E-03	9.317E-04
GR(B10011	592	5.91E-06	1.426E-03	1.275E-03	1.228E-03	2.051E-03	2.051E-03	1.143E-03
GR(B10011	593	4.11E-06	9.775E-04	8.756E-04	8.438E-04	1.401E-03	1.401E-03	7.882E-04
GR(B10011	594	6.39E-06	1.506E-03	1.348E-03	1.298E-03	2.161E-03	2.162E-03	1.207E-03
GR(B10011	595	5.52E-06	1.279E-03	1.147E-03	1.105E-03	1.835E-03	1.835E-03	1.031E-03
GR(B10012	519	5.04E-05	1.596E-02	1.270E-02	1.486E-02	2.332E-02	2.332E-02	1.159E-02
GR(B10012	520	7.49E-05	2.274E-02	1.756E-02	2.162E-02	3.338E-02	3.338E-02	1.621E-02
GR(B10012	521	3.87E-05	1.236E-02	9.517E-03	1.182E-02	1.806E-02	1.806E-02	8.808E-03
GR(B10012	522	8.28E-05	2.561E-02	2.267E-02	2.139E-02	3.672E-02	3.673E-02	1.947E-02
GR(B10012	561	3.46E-06	8.082E-04	6.505E-04	7.734E-04	1.204E-03	1.204E-03	6.049E-04
GR(B10012	562	1.84E-06	4.832E-04	3.834E-04	4.606E-04	7.132E-04	7.134E-04	3.553E-04
GR(B10012	563	3.12E-06	8.192E-04	6.503E-04	7.807E-04	1.209E-03	1.210E-03	6.024E-04
GR(B10012	564	1.37E-06	3.200E-04	2.577E-04	3.045E-04	4.763E-04	4.764E-04	2.390E-04
GR(B10012	566	6.89E-06	1.606E-03	1.294E-03	1.537E-03	2.393E-03	2.393E-03	1.203E-03
GR(B10012	567	3.13E-06	8.095E-04	6.433E-04	7.720E-04	1.196E-03	1.196E-03	5.964E-04
GR(B10012	568	2.21E-06	5.716E-04	4.543E-04	5.447E-04	8.441E-04	8.443E-04	4.210E-04



Controlled Distribution



REFERENCE : H-P-RP-AI-0040

DATE : 29/SEP/06

ISSUE : 06

Page : 161/405

PLANCK ITP-170-P – Temperature considered with uncertainty							
NODES	GR [W/K ⁴]	A1 Heat Flow [W]	A2 Heat Flow [W]	A3 Heat Flow [W]	B1 Heat Flow [W]	B2 Heat Flow [W]	C Heat Flow [W]
GR(B10012 569)	2.89E-06	6.736E-04	5.428E-04	6.408E-04	1.003E-03	1.003E-03	5.034E-04
GR(B10012 571)	7.37E-06	1.690E-03	1.361E-03	1.617E-03	2.519E-03	2.519E-03	1.266E-03
GR(B10012 572)	5.52E-06	1.349E-03	1.078E-03	1.288E-03	1.997E-03	1.998E-03	1.001E-03
GR(B10012 573)	4.37E-06	1.068E-03	8.540E-04	1.018E-03	1.581E-03	1.581E-03	7.923E-04
GR(B10012 574)	3.50E-06	8.022E-04	6.468E-04	7.636E-04	1.195E-03	1.195E-03	6.002E-04
GR(B10012 581)	1.56E-06	4.323E-04	3.851E-04	3.698E-04	6.189E-04	6.191E-04	3.401E-04
GR(B10012 582)	8.13E-07	2.234E-04	1.991E-04	1.914E-04	3.198E-04	3.199E-04	1.763E-04
GR(B10012 583)	1.56E-06	4.221E-04	3.767E-04	3.624E-04	6.045E-04	6.047E-04	3.350E-04
GR(B10012 584)	7.48E-07	1.935E-04	1.730E-04	1.662E-04	2.767E-04	2.768E-04	1.534E-04
GR(B10012 585)	6.10E-07	1.558E-04	1.394E-04	1.341E-04	2.227E-04	2.227E-04	1.241E-04
GR(B10012 586)	1.25E-06	3.147E-04	2.819E-04	2.714E-04	4.501E-04	4.501E-04	2.519E-04
GR(B10012 587)	1.19E-06	2.981E-04	2.668E-04	2.563E-04	4.253E-04	4.254E-04	2.371E-04
GR(B10012 588)	7.74E-07	1.910E-04	1.713E-04	1.648E-04	2.725E-04	2.726E-04	1.528E-04
GR(B10012 589)	1.14E-06	2.779E-04	2.494E-04	2.402E-04	3.966E-04	3.967E-04	2.232E-04
GR(B10012 590)	9.95E-06	2.564E-03	2.296E-03	2.214E-03	3.666E-03	3.667E-03	2.073E-03
GR(B10012 591)	4.46E-06	1.145E-03	1.026E-03	9.900E-04	1.627E-03	1.628E-03	9.286E-04
GR(B10012 592)	5.45E-06	1.348E-03	1.209E-03	1.165E-03	1.924E-03	1.924E-03	1.087E-03
GR(B10012 593)	4.69E-06	1.144E-03	1.028E-03	9.914E-04	1.627E-03	1.628E-03	9.280E-04
GR(B10012 594)	4.62E-06	1.117E-03	1.003E-03	9.664E-04	1.590E-03	1.591E-03	9.007E-04
GR(B10012 595)	4.17E-06	9.916E-04	8.918E-04	8.601E-04	1.411E-03	1.412E-03	8.044E-04
Total I/F fluxes [W]		2.567	2.152	2.318	3.766	3.767	1.943

Table 7.2-7 PLANCK - ITP-170-P



Controlled Distribution



REFERENCE : H-P-RP-AI-0040

DATE : 29/SEP/06

ISSUE : 06

Page : 162/405

PLANCK ITP-220-P						
NODE	Requirement		Results			
	FFT @ 1/5000 Hz [K]	FFT @ 1/60 Hz [K]	FFT @ 1/5000 Hz [K]	Status	FFT @ 1/60 Hz [K]	Status
COLD CASE – BOL SCC1 On						
10021	0.02	0.02	2.653*10 ⁻⁶	Compl.	1.09*10 ⁻⁹	Compl.
10022	0.02	0.02	3.402*10 ⁻⁶	Compl.	4.173*10 ⁻¹⁰	Compl.
10023	0.02	0.02	3.965*10 ⁻⁶	Compl.	1.629*10 ⁻⁹	Compl.
10024	0.02	0.02	3.627*10 ⁻⁶	Compl.	1.982*10 ⁻⁹	Compl.
10025	0.02	0.02	1.915*10 ⁻⁵	Compl.	2.208*10 ⁻⁹	Compl.
10026	0.02	0.02	2.295*10 ⁻⁶	Compl.	1.335*10 ⁻⁹	Compl.
COLD CASE – BOL SCC2 On						
10021	0.02	0.02	2.606*10 ⁻⁶	Compl.	1.378*10 ⁻⁹	Compl.
10022	0.02	0.02	1.869*10 ⁻⁶	Compl.	1.055*10 ⁻⁹	Compl.
10023	0.02	0.02	3.137*10 ⁻⁶	Compl.	1.298*10 ⁻⁹	Compl.
10024	0.02	0.02	3.127*10 ⁻⁶	Compl.	1.238*10 ⁻⁹	Compl.
10025	0.02	0.02	2.013*10 ⁻⁵	Compl.	7.102*10 ⁻¹⁰	Compl.
10026	0.02	0.02	2.717*10 ⁻⁶	Compl.	1.032*10 ⁻⁹	Compl.
HOT CASE – EOL SCC1 On						
10021	0.02	0.02	2.955*10 ⁻⁶	Compl.	1.571*10 ⁻⁹	Compl.
10022	0.02	0.02	3.339*10 ⁻⁶	Compl.	1.856*10 ⁻⁹	Compl.
10023	0.02	0.02	3.422*10 ⁻⁶	Compl.	3.552*10 ⁻¹⁰	Compl.
10024	0.02	0.02	3.404*10 ⁻⁶	Compl.	1.583*10 ⁻⁹	Compl.
10025	0.02	0.02	1.946*10 ⁻⁵	Compl.	1.996*10 ⁻⁹	Compl.
10026	0.02	0.02	3.045*10 ⁻⁶	Compl.	1.436*10 ⁻⁹	Compl.
HOT CASE – EOL SCC2 On						
10021	0.02	0.02	3.011*10 ⁻⁶	Compl.	4.399*10 ⁻¹⁰	Compl.
10022	0.02	0.02	2.815*10 ⁻⁶	Compl.	1.595*10 ⁻⁹	Compl.
10023	0.02	0.02	3.383*10 ⁻⁶	Compl.	1.249*10 ⁻¹⁰	Compl.
10024	0.02	0.02	3.398*10 ⁻⁶	Compl.	1.807*10 ⁻⁹	Compl.
10025	0.02	0.02	1.977*10 ⁻⁵	Compl.	1.759*10 ⁻⁹	Compl.
10026	0.02	0.02	3.085*10 ⁻⁶	Compl.	3.452*10 ⁻¹⁰	Compl.

Table 7.2-8 PLANCK - ITP-220-P



Controlled Distribution



REFERENCE : H-P-RP-AI-0040

DATE : 29/SEP/06

ISSUE : 06

Page : 163/405

PLANCK ITP-230-P					
Panels	Requirement	COLD CASE BOL SCC1 On		COLD CASE BOL SCC2 On	
	SD @ 1/60 Hz [K/Hz ^{0.5}]	SD @ 1/60 Hz [K/Hz ^{0.5}]	Status	SD @ 1/60 Hz [K/Hz ^{0.5}]	Status
Pan +Z (3001-3048)	0.01	4.293*10 ⁻⁷	Compl	6.974*10 ⁻⁷	Compl
Pan +Y+Z (3101-3172)	0.01	1.548*10 ⁻⁷	Compl	7.758*10 ⁻⁷	Compl
Pan +Y (3201-3248)	0.01	3.287*10 ⁻⁶	Compl	1.072*10 ⁻⁶	Compl
Pan +Y-Z (3301-3372)	0.01	1.161*10 ⁻⁵	Compl.	2.646*10 ⁻⁴	Compl.
Pan -Z (3401-3448)	0.01	2.820*10 ⁻⁵	Compl.	4.627*10 ⁻⁴	Compl.
Pan -Y-Z (3501-3572)	0.01	5.478*10 ⁻⁶	Compl.	2.900*10 ⁻⁵	Compl
Pan -Y (3601-3648)	0.01	2.021*10 ⁻³	Compl	2.074*10 ⁻³	Compl
Pan -Y+Z (3701-3772)	0.01	5.788*10 ⁻⁷	Compl	4.081*10 ⁻⁷	Compl
Panels	Requirement	HOT CASE EOL SCC1 On		HOT CASE EOL SCC2 On	
	SD @ 1/60 Hz [K/Hz ^{0.5}]	SD @ 1/60 Hz [K/Hz ^{0.5}]	Status	SD @ 1/60 Hz [K/Hz ^{0.5}]	Status
Pan +Z (3001-3048)	0.01	5.402*10 ⁻⁷	Compl	6.922*10 ⁻⁷	Compl
Pan +Y+Z (3101-3172)	0.01	4.358*10 ⁻⁶	Compl	3.165*10 ⁻⁶	Compl
Pan +Y (3201-3248)	0.01	4.552*10 ⁻⁷	Compl	4.164*10 ⁻⁷	Compl
Pan +Y-Z (3301-3372)	0.01	7.673*10 ⁻⁶	Compl.	9.117*10 ⁻⁶	Compl.
Pan -Z (3401-3448)	0.01	6.159*10 ⁻⁶	Compl.	2.064*10 ⁻⁵	Compl.
Pan -Y-Z (3501-3572)	0.01	2.858*10 ⁻⁶	Compl.	2.383*10 ⁻⁶	Compl
Pan -Y (3601-3648)	0.01	2.162*10 ⁻³	Compl	1.977*10 ⁻³	Compl
Pan -Y+Z (3701-3772)	0.01	2.045*10 ⁻⁶	Compl	1.138*10 ⁻⁶	Compl

Table 7.2-9 PLANCK - ITP-230-P



Controlled Distribution



REFERENCE : H-P-RP-AI-0040

DATE : 29/SEP/06

ISSUE : 06

Page : 164/405

PLANCK ITI-030-P					
COLD CASE – BOL SCC1 On					
Node	Unit	Max [K/s]	Req. [K/s]	Status	Margin [k/s]
522	PAU	0.000021	0.000833	Compl.	
519/520/521	BEU	0.000016	0.000833	Compl.	
525	DAE	0.000025	0.000833	Compl.	
		Max [K/s]	GOAL [K/s]		
522	PAU	0.000021	0.000305556	Compl.	
519/520/521	BEU	0.000016	$5.55556 \cdot 10^{-5}$	Compl.	
525	DAE	0.000025	$5.55556 \cdot 10^{-5}$	Compl.	
COLD CASE – BOL SCC2 On					
522	PAU	0.000026	0.000833	Compl.	
519/520/521	BEU	0.000021	0.000833	Compl.	
525	DAE	0.000029	0.000833	Compl.	
		Max [K/s]	GOAL [K/s]		
522	PAU	0.000026	0.000305556	Compl.	
519/520/521	BEU	0.000021	$5.55556 \cdot 10^{-5}$	Compl.	
525	DAE	0.000029	$5.55556 \cdot 10^{-5}$	Compl.	
HOT CASE – EOL SCC1 On					
Node	Unit	Max [K/s]	Req. [K/s]	Status	Margin [k/s]
522	PAU	0.000023	0.000833	Compl.	
519/520/521	BEU	0.00002	0.000833	Compl.	
525	DAE	0.000027	0.000833	Compl.	
		Max [K/s]	GOAL [K/s]		
522	PAU	0.000023	0.000305556	Compl.	
519/520/521	BEU	0.00002	$5.55556 \cdot 10^{-5}$	Compl.	
525	DAE	0.000027	$5.55556 \cdot 10^{-5}$	Compl.	
HOT CASE – EOL SCC2 On					
522	PAU	0.000023	0.000833	Compl.	
519/520/521	BEU	0.00002	0.000833	Compl.	
525	DAE	0.000027	0.000833	Compl.	
		Max [K/s]	GOAL [K/s]		
522	PAU	0.000023	0.000305556	Compl.	
519/520/521	BEU	0.00002	$5.55556 \cdot 10^{-5}$	Compl.	
525	DAE	0.000027	$5.55556 \cdot 10^{-5}$	Compl.	

Table 7.2-10 PLANCK - ITI-030-P



Controlled Distribution



REFERENCE : H-P-RP-AI-0040

DATE : 29/SEP/06

ISSUE : 06

Page : 165/405

In the following table 4.2-10 the maximum value of BED fluctuation for every single absorbing bed is reported, both in cold (cases P1 and P2) and hot cases (cases Q1 and Q2).

CASE	Cooling BED	BED#1	BED#2	BED#3	BED#4	BED#5	BED#6
P1 – BOL SCC1 on	5		5.10	4.61	5.55		
	6			5.10	4.61	5.55	
	1				5.10	4.61	5.55
	2	5.55				5.10	4.61
	3	4.60	5.55				5.10
	4	5.09	4.60	5.55			
P2 – BOL SCC2 on	5		4.90	4.65	5.78		
	6			5.33	4.81	5.86	
	1				5.40	4.87	5.66
	2	5.77				4.89	4.64
	3	4.82	5.86				5.34
	4	5.41	4.88	5.66			
Q1 – EOL SCC1 on	5		5.11	4.83	5.30		
	6			5.12	4.89	5.36	
	1				5.11	4.83	5.31
	2	5.37				5.13	4.89
	3	4.89	5.36				5.13
	4	5.11	4.83	5.30			
Q2 – EOL SCC2 on	5		5.25	5.10	5.58		
	6			5.25	5.10	5.59	
	1				5.25	5.10	5.59
	2	5.59				5.25	5.10
	3	5.10	5.59				5.25
	4	5.25	5.10	5.59			

Table 7.2-11 PLANCK – SCC STABILITY



Controlled Distribution

BOL SCC1 on (COLD case)		
	Requirement	Requirement
	[0.1°C / hr]	[0.25°C / day]
Max Delta T 920-925	-0.005	-0.047
Max Delta T 920-930	-0.031	0.016
Max Delta T 925-930	-0.030	0.061
BOL SCC2 on(COLD case)		
	Requirement	Requirement
	[0.1°C / hr]	[0.25°C / day]
Max Delta T 920-925	-0.008	-0.031
Max Delta T 920-930	-0.032	0.032
Max Delta T 925-930	-0.029	0.062
EOL SCC1 on (HOT case)		
	Requirement	Requirement
	[0.1°C / hr]	[0.25°C / day]
Max Delta T 920-925	-0.009	-0.021
Max Delta T 920-930	-0.031	0.082
Max Delta T 925-930	-0.029	0.097
EOL SCC2 on (HOT case)		
	Requirement	Requirement
	[0.1°C / hr]	[0.25°C / day]
Max Delta T 920-925	-0.009	-0.020
Max Delta T 920-930	-0.031	0.081
Max Delta T 925-930	-0.029	0.096
	BOL – EOL SCC1 on	BOL – EOL SCC2 on
	Requirement	Requirement
	[1.5°C / life]	[1.5°C / life]
Max Delta T 920-925	0.766	0.713
Max Delta T 920-930	-0.265	-0.278
Max Delta T 925-930	-0.989	-0.945

Table 7.2.12 PLANCK – gradient between each tank

8 THERMAL ANALYSIS

In the thermal analysis, the presence of heater, controlled by means thermistors, has been simulated comparing the temperature with two fixed thresholds. The simulation of this control is relatively simply in the transient case: if the controlled node has a temperature below the on-threshold the heater dissipation is considered in the TMM; if the temperature is above the off-threshold the heaters dissipation is set at 0 W; if the temperature is within the “on threshold” and “off threshold” the heater status of “on” or “off” doesn’t change.

8.1 HERSCHEL Thermal Analysis

Two fins on the +Y and –Y Panel have been designed to eliminate the Solar Flux on the two Panels as described in the Design Report AD7.

Due to the use of these fins, the difference on the Temperature results between the case with a rotation of +1deg. and –1deg. around X-axis, is lower then 1 °C.

For this reason, the Cold Cases were performed using only one position (Rot X= –1°).

TRANSIENT CASE

According to AD9, the following sizing cases have been performed:

Case A÷F = Hot Cases in worst Attitude (-30° around the Yaxis and +/- 1° on the Xaxis) and in operating Modes:

- Mode 1 (sizing for HIFI units)
- Mode 2 (sizing for PACS units) in Photometry or Spectroscopy
- TT&C in Nominal mode (21h in Telecom 3h in Scientific)

Case G÷H = Cold Cases in worst Attitude, (+30° around the Yaxis) and in operating Modes:

- Mode 1 (sizing for HIFI)
- Mode 3 (sizing for SPIRE)
- TT&C in Nominal Mode (21h in Telecom 3h in Scientific)

Case I = Cold Case in Survival Attitude, (+5° around the Yaxis) and in operating Modes:

- Survival = all warm units are Switched-Off
- TT&C in Telecom Mode

In all the Nominal Cases from A to H some control are activated:

- the HIFI units FHWOV and FHWOH are controlled by a Fine Control Law at the updated thermal reference point on the panel skin (node 654007 and 660706) respectively at set point 4.5°C and 3.5°C (see [AD31])
- the STR baseplate is controlled by a Fine Control Law at the set point 0°C
- the STR baffle is controlled at the set point 14°C/14.5°C
- the GYRO unit is controlled at the set point 62.5°C/63°C
- the CRS units are controlled at the set point 49.0°C/49.5°C

Solar constant values are defined in [AD9].

CASE	BOL/ EOL	SUN ON PANEL	SAA [deg]	ATTITUDE	SOLAR CONSTANT [W/m ²]	DISSIPATION MODE
A	EOL	+X+Y	30	Rot X = +1 Rot Y = -30	Winter: 1405	TT&C Nominal / MODE1
B	EOL	+X+Y	30	Rot X = +1 Rot Y = -30	Winter: 1405	TT&C Nominal / MODE2 Photometry
C	EOL	+X+Y	30	Rot X = +1 Rot Y = -30	Winter: 1405	TT&C Nominal / MODE2 Spectroscopy
D	EOL	+X-Y	30	Rot X = -1 Rot Y = -30	Winter: 1405	TT&C Nominal / MODE1
E	EOL	+X-Y	30	Rot X = -1 Rot Y = -30	Winter: 1405	TT&C Nominal / MODE2 Photometry
F	EOL	+X-Y	30	Rot X = -1 Rot Y = -30	Winter: 1405	TT&C Nominal / MODE2 Spectroscopy
G	BOL	+X-Y	30	Rot X = -1 Rot Y = +30	Summer: 1285	TT&C Nominal / MODE3
H	BOL	+X-Y	30	Rot X = -1 Rot Y = +30	Summer: 1285	TT&C Nominal / MODE1
I	BOL	+X-Y	5	Rot X = 0 Rot Y = +5	Summer: 1285	TT&C Telecom / SurvivalBOL

Table 8.1-1 HERSCHEL – Analysis Cases

TRANSIENT WITH ATTITUDE CHANGE

Two Cases with an Attitude Change have been performed with the Warm Units in MODE1: P and Q.

The scope of these transients is to verify the stability requirements. As reported in Requirements paragraph, the stability is reached for all the units that have a requirement.

A fine control law is implemented on the STR, -Y Panel Unit FHWOH and on the -Y-Z Unit FHWOV the units that require a dedicated heater power in nominal conditions.

The analysed cases are:

- P: Cold Transient:
 - Starting from a temperature level corresponding to a BOL with Sun on +X -Y axis, SAA=+30°/-1° in Summer season
 - Ending to a BOL case with Sun on -X -Y axis, SAA=-30°/-1° in Summer season
 - Warm Units in MODE1
 - TT&C units: 21 hours Scientific Mode and 3 hours Telecom Mode
 - Nominal heater dissipations
 - Fine control law on Units: FHWOV, FHWOH, STR (control also on primary baffle).
 - GYRO controlled within 0.5°C at set-point
 - CRS controlled within 0.5°C at set-point
 - Duration of change of attitude (7°/min): 514s
 - Overall duration of transient case: 130 h

- Q: Hot Transient:
 - Starting from a temperature level corresponding to a EOLcase with Sun on +X -Y axis, SAA=+30°/-1° in Winter season



Controlled Distribution



REFERENCE : H-P-RP-AI-0040

DATE : 29/SEP/06

ISSUE : 06

Page : 169/405

-
- Ending to a EOL case with Sun on -X -Y axis, SAA=-30°/-1° in Winter season
 - Warm Units in MODE1
 - TT&C units: 21 hours Scientific Mode and 3 hours Telecom Mode
 - Nominal heater dissipations
 - Fine control law on Units: FHWOV, FHWOH, STR (control also on primary baffle).
 - GYRO controlled within 0.5°C at set-point
 - CRS controlled within 0.5°C at set-point
 - Duration of change of attitude (7°/min): 514s
 - Overall duration of transient case: 130 h

REDUNDANCY TRANSIENT ANALYSIS

A series of additional analysis have been performed to verify the temperatures behaviour when the redundancy units are activated. The analysis results are reported in paragraph 8.4.4



Controlled Distribution



REFERENCE : H-P-RP-AI-0040

DATE : 29/SEP/06

ISSUE : 06

Page : 170/405

8.2 Herschel Heater Sizing and Breakdown

A heater definition approach was followed in order to define the heater power needed by the TCS.

For this scope a heater power uncertainty analysis has been performed [AD22].

The Heater circuit breakdown with the heater power impressed on the TMM nodes is shown in Table 8.2-1.

The threshold operative and not operative are listed in the table, but also in the survival case the operative threshold are used (except for the control law that are inactive) to maintain the SVM temperature level sufficiently high. The RCS temperature in survival are critical and this solution can avoid other design impacts.

The last updating (from issue 05) is highlighted in blue and it concern in particular CRS units and STR primary baffle heaters control. In Survival Mode the units with a Control Law will be controlled with a maximum threshold 4°C lower than the Control law set point. This has been decided to avoid that the units temperature will go too low and that the control law takes too much time to recover the set point level.

Heater line	TCS ID	HEATER's location	Heaters on Node	Power on node [W]	Power line @27 V [W]	UNIT ON Threshold [°C]	SURVIVAL Threshold [°C]
TCS Line 01	HTR104	close to XPND1	6134	11.39	11.39	-9/-6	-9/-6
TCS Line 02	HTR105	close to XPND2	6110	11.39	11.39	-9/-6	-9/-6
TCS Line 03	HTR204	inside BATTERY	204	14.9	14.90	1/4	1/4
TCS Line 04	HTR7071	TANK	70/71	0.77/0.77	1.54	fixed	fixed
TCS Line 05	HTR301	close to FPSPU, FPDPDPU	6309	15.51	31.00	-14/-11	-14/-11
			6313	15.51/2			
			6314	15.51/2			
TCS Line 06	HTR304	close to FPBOLC	6338	4.7	9.40	-14/-11	-14/-11
			6324	4.7			
TCS Line 07	HTR110	CRS1	130	24.3	24.3	49.0/49.5	49.0/49.5
TCS Line 08	HTR305	close to FPDECMEC	6342	11.39	27.48	-14/-11	-14/-11
			6320	11.39			
			6344	4.7			
TCS Line 09	HTR1523NS	Pipes	-	-	5.67	+23/+24	+23/+24
TCS Line 10	HTR401	close to CCU, HSDCU, HSFCU	6402	4.7	44.50	-9/-6	-9/-6
			6416	8.1			
			6428	8.1			
			6446	15.51			
			6421	8.1			
TCS Line 11	HTR1562	Pipes	-	-	5.54	+23/+24	+23/+24
TCS Line 12	HTR501	Close to FHWOV	654706	11.39/4	22.80	C.L. Set point on 654007 4.5°C	-2.5/+0.5
			654702	11.39/4			
			653914	11.39/4			
			653910	11.39/4			
			653102	11.39/4			
			653106	11.39/4			
			653110	11.39/4			
TCS Line 13	HTR502	Close to FHHRV	6551	8.1	39.00	-9/-6	-9/-6
			6567	8.1			



Controlled Distribution



REFERENCE : H-P-RP-AI-0040

DATE : 29/SEP/06

ISSUE : 06

Page : 171/405

Heater line	TCS ID	HEATER's location	Heaters on Node	Power on node [W]	Power line @27 V [W]	UNIT ON Threshold [°C]	SURVIVAL Threshold [°C]
			6553	11.39			
			6569	11.39			
TCS Line 14	HTR80052	STR primary baffle	80052	7.05	7.05	14/14.5	14/14.5
TCS Line 15	HTR506	close to FHWEV, FHICU	6528	8.1	35.70	1 / 4	1 / 4
			6530	11.39			
			6521	8.1			
			6506	8.1			
TCS Line 16	HTR601	close to FHWOH	660606	8.1/3	32.40	C.L. Set point on 660706 3.5°C	-3.5/-0.5
			660607	8.1/3			
			660608	8.1/3			
			661811	8.1/3			
			661812	8.1/3			
			661909	8.1/3			
			662011	8.1/3			
			662010	8.1/3			
			662009	8.1/3			
			660609	8.1/3			
			660613	8.1/3			
			661801	8.1/3			
TCS Line 17	HTR602	close to FHWEH	6603	8.1	32.40	1 / 4	1 / 4
			6605	8.1			
			6615	8.1			
			6617	8.1			
TCS Line 18	HTR603	close to FHHRH	6664	11.39	39.00	-9/-6	-9/-6
			6665	8.1/2			
			6666	8.1/2			
			6627	8.1			
			6628	11.39/2			
			6629	11.39/2			
TCS Line 19	HTR604	close to FHLCU, FHIFH	6634	8.1	20.90	-9/-6	-9/-6
			6670	8.1			
			6635	4.7*2/3			
			6636	4.7/3			
TCS Line 20	HTR605	close to FHLSU	6654	8.1	29.00	11/14	11/14
			6656	8.1			
			6630	8.1			
			6632	4.7			
TCS Line 21	HTR702	on RWL2	702	11.39	11.39	+1/+4	+1/+4
TCS Line 22	HTR704	on RWL4	704	11.39	11.39	+1/+4	+1/+4
TCS Line 23	HTR701	on RWL1	701	11.39	11.39	+1/+4	+1/+4
TCS Line 24	HTR703	on RWL3	703	11.39	11.39	+1/+4	+1/+4



Controlled Distribution



REFERENCE : H-P-RP-AI-0040

DATE : 29/SEP/06

ISSUE : 06

Page : 172/405

Heater line	TCS ID	HEATER's location	Heaters on Node	Power on node [W]	Power line @27 V [W]	UNIT ON Threshold [°C]	SURVIVAL Threshold [°C]
TCS Line 25	HTR70	on TANK +Y	70	5.4	5.4	11/14	11/14
TCS Line 26	HTR71	on TANK -Y	71	5.4	5.4	11/14	11/14
TCS Line 27	HTR20000	STR panel	20002	1.32	21.10	C.L. Set point on average 20012 20013 20020 20021 0°C	-7/-4
			20003	1.32			
			20006	1.32			
			20007	1.32			
			20009	1.32			
			20017	1.32			
			20020	1.32			
			20021	1.32			
			20012	1.32			
			20013	1.32			
			20016	1.32			
			20024	1.32			
			20026	1.32			
20027	1.32						
20030	1.32						
20031	1.32						
TCS Line 28	HTR507	on FHIFV	6544 6545	11.39/2 11.39/2	11.39	No C.L. needed	-9/-6
TCS Line 29	HTR8133	on FCV A1A	8133	1.43	1.43	11/14	11/14
TCS Line 30	HTR8233	on FCV C2A	8233	1.43	1.43	11/14	11/14
TCS Line 31	HTR8333	on FCV C1A	8333	1.43	1.43	11/14	11/14
TCS Line 32	HTR8433	on FCV A2A	8433	1.43	1.43	11/14	11/14
TCS Line 33	HTR8533	on FCV C4A	8533	1.43	1.43	11/14	11/14
TCS Line 34	HTR8633	on FCV C3A	8633	1.43	1.43	11/14	11/14
TCS Line 35	HTR1544	Pipes	-	-	5.24	+23/+24	+23/+24
TCS Line 36	HTR81052	STR2 primary baffle	81052	7.05	7.05	14/14.5	14/14.5
TCS Line 37	HTR1554	Pipes	-	-	9.35	+23/+24	+23/+24
TCS Line 38	HTR100	on GYRO	81	45.22	45.22	62.5/63	62.5/63
TCS Line 39	HTR8134	on FCV A1B	8134	1.43	1.43	11/14	11/14
TCS Line 40	HTR8234	on FCV C2B	8234	1.43	1.43	11/14	11/14
TCS Line 41	HTR8334	on FCV C1B	8334	1.43	1.43	11/14	11/14
TCS Line 42	HTR8434	on FCV A2B	8434	1.43	1.43	11/14	11/14
TCS Line 43	HTR8534	on FCV C4B	8534	1.43	1.43	11/14	11/14
TCS Line 44	HTR8634	on FCV C3B	8634	1.43	1.43	11/14	11/14
TCS Line 45	HTR1513	Pipes	-	--	5.74	+23/+24	+23/+24
TCS Line 46	HTR1506	Pipes	-	-	4.68	+23/+24	+23/+24
TCS Line 47	HTR1535	Pipes	-	-	4.82	+23/+24	+23/+24
TCS Line 48	HTR1550	PT LV1 LV2 LF	-	-	4.9	+23/+24	+23/+24
TCS Line 49	HTR131	CRS2	131	24.3	24.3	49.0/49.5	49.0/49.5

Table 8.2-1 HERSCHEL – Heater Circuits Breakdown and Temperature Thresholds



8.3 Thermal stability

In order to meet the stability requirement for the units having an heater control (501 FHWOV, 601 FHWOH, Star trackers) an adequate control law has been designed.

A dedicated set of thermal analyses (transient cases) has been performed in order to verify the stability requirement. The residual logic has been implemented in the FHWOV & FHWOH control law, according to H-P-ASP-CR-0865. The description of the control law criterion with the thermal analysis results is reported in [AD23].

For the units that have to stay between +/-0.5°C as GYRO, CRS and STR primary baffle (to improve the STR stability performances) an heater control has been implemented with a threshold of:

GYRO	62.5°C/ 63°C
CRS 1&2	49.0°C/ 49.5°C
STR PRIMARY BAFFLE	14°C/ 14.5°C

8.4 Herschel Thermal analysis results

8.4.1 Transient Results

The temperature results hereafter presented (Tables 8.4.1-1 to 8.4.1-4) refer to the Sizing Cases reported in paragraph 8.1. The Temperatures values are reported with and without uncertainty for all the Units according to the uncertainty analysis [AD21]. The units actively controlled don't have any uncertainty: GYRO, FHWOV, FHWOH, STR1.

The temperature uncertainty used is generally 8 °C ([AD21], with control law case) except for the units:

- With uncertainty higher than 8°C. The real value is considered.
- With temperature higher than maximum limit. The real value is considered.

For the survival case the reference uncertainty is always takes from [AD21] but for the case without control law.

The Gyro has to be controlled in temperature in way that its temperature not changes more than 1 °C.

For this reason calculated the maximum temperature in EOL (Hot case) the threshold of heater switch-on has been defined about 1°C less (62°C). Of course when the analysis condition request heater no uncertainty will be applied at the Gyro, while if the temperature is higher than the heater threshold value will be applied the uncertainty calculated without control (8.5 °C, see [AD21]).

The Tables contain for the main S/L items, the relevant TMM node, its description, the temperature results in the transient nominal analysis with the minimum values reported for the Cold cases and the maximum values reported for the Hot cases, the uncertainty applied, the temperature with the relative uncertainty applied, the heater enabled according to the case analysed (identified by the "h" reported near the temperature value), the operative and non operative limits. All the temperatures are in degree Celsius.

NODE	LABEL	TEMPERATURE RESULTS AND LIMITS												
		G		H		UFP [°C]	G		H		MIN OPER. [°C]	MAX OPER. [°C]	MIN N.OPER [°C]	MAX N.OPER [°C]
		TEMP [°C]	PW [W]	TEMP [°C]	PW [W]		TEMP-UFP [°C]	TEMP-UFP [°C]						
4	VMC	6.5	0.0	6.6	0.0	7.4	-0.9	-0.9	-10	50	-20	60		
5	SAS HOUSING +Z	21.2	0.0	21.3	0.0	8	13.2	13.3	-70	80	-80	90		
16	MGA+Z SEPTUM	55.1	0.0	55.1	0.0	12.4	42.7	42.7	-150	150	-150	150		
21	LGA+Z	33.1	0.0	33.1	0.0	8	25.1	25.1	-150	120	-150	120		
41	LGA-Z	-64.5	0.0	-64.4	0.0	8	-72.5	-72.4	-150	120	-150	120		
45	SAS HOUSING -Z	-16.4	0.0	-16.1	0.0	8	-24.4	-24.1	-70	80	-80	90		
49	WINDOW SREM	4.4	2.6	4.7	2.6	8	-3.6	-3.3	-10	50	-45	90		
56	AAD HOUSING	46.1	0.0	46.1	0.0	8	38.1	38.1	-70	70	-80	80		
70	TANK1	11.0	0.0	11.0	0.0	0	11.0h	11.0h	10	45	10	45		
71	TANK2	11.0	0.0	11.0	0.0	0	11.0h	11.0h	10	45	10	45		
81	GYRO_D1	62.1	0.0	62.1	0.0	0	62.1h	62.1h	-15	65	-25	65		
101	RFDN	2.0	0.0	2.1	0.0	8	-6.0	-5.9	-25	55	-35	65		
122	EPC1_D1	0.3	0.0	0.4	0.0	8	-7.7	-7.7	-20	60	-30	70		
123	EPC2_D1	-9.1	0.0	-9.0	0.0	8.2	-17.3	-17.2	-20	60	-30	70		
104	TRANSX1	10.8	21.0	10.8	21.0	7.6	3.2	3.2	-10	45	-20	55		
105	TRANSX2	-0.3	10.0	-0.3	10.0	0	-0.3h	-0.3h	-10	45	-20	55		
126	TWTA1_D1	1.8	0.0	1.9	0.0	7.9	-6.1	-6.0	-20	60	-30	70		
127	TWTA2_D1	-10.8	0.0	-10.8	0.0	8.1	-18.9	-18.9	-20	60	-30	70		
146	TWTA1_HEAD_D1	2.4	0.0	2.5	0.0	7.9	-5.5	-5.4	-20	60	-30	70		
147	TWTA2_HEAD_D1	-11.1	0.0	-11.0	0.0	8.1	-19.2	-19.1	-20	60	-30	70		
130	CRS1_D1	48.4	7.1	48.4	7.1	0	48.4h	48.4h	0	50	-10	60		
131	CRS2_D1	48.4	7.1	48.4	7.1	0	48.4h	48.4h	0	50	-10	60		
221	PCDU_D1	12.9	72.8	13.0	72.8	8	4.9	5.0	-10	47	-20	57		
222	CDMU_D1	10.5	37.7	10.6	37.7	8	2.5	2.6	-10	45	-20	55		

Controlled Distribution



REFERENCE : H-P-RP-AI-0040

DATE : 29/SEP/06

ISSUE : 06

Page : 175/405

NODE	LABEL	TEMPERATURE RESULTS AND LIMITS										
		G	G	H	H	UFP [°C]	G	H	MIN OPER. [°C]	MAX OPER. [°C]	MIN N.OPER [°C]	MAX N.OPER [°C]
		TEMP [°C]	PW [W]	TEMP [°C]	PW [W]		TEMP- UFP [°C]	TEMP-UFP [°C]				
223	ACC_D1	13.2	32.1	13.3	32.1	8	5.2	5.3	-10	45	-20	55
204	BATT	1.0	0.0	1.0	0.0	0	1.0h	1.0h	0	35	0	35
321	FPSPU1_2_D1	9.9	30.3	10.0	30.3	8	1.9	2.0	-15	45	-30	60
323	FPDPU_D1	-2.3	14.7	-2.2	14.7	8	-10.3	-10.2	-15	45	-30	60
324	FPBOLC_D1	-7.8	6.6	-7.7	6.6	8	-15.8	-15.7	-15	45	-30	60
325	FPMECDEC_D1	-3.1	15.9	-3.0	15.9	8	-11.1	-11.0	-15	45	-30	60
401	CCU	7.3	5.4	7.7	5.4	8	-0.7	-0.3	-10	40	-20	50
424	HSDCU_D1	11.2	37.0	11.6	37.0	8	3.2	3.6	-15	45	-35	60
425	HSDPU_D1	5.7	15.3	5.9	15.3	8	-2.3	-2.1	-15	45	-35	60
426	HSFCU_D1	11.8	42.9	11.9	42.9	8	3.8	3.9	-15	45	-35	60
521	FHWOV_D1 BASEPLATE	8.9	1.5	8.9	1.5	0	8.9c.l	8.9c.l	5	15	-25	55
654007	Internal Rad -Y-Z under foot	4.5	0.0	4.5	0.0	0	4.5c.l	4.5c.l	0	10	-25	55
522	FHHRV_D1	15.9	66.3	16.8	66.3	9	6.9	7.8	-10	40	-25	55
523	FHICU_D1	12.6	29.0	14.6	31.4	8.3	4.3	6.3	-25	40	-30	60
524	FHFCU_D1	9.3	13.0	10.3	13.0	8	1.3	2.3	-10	40	-25	55
526	FHWEV_D1	11.2	25.7	11.9	25.7	8	3.2	3.9	0	30	-25	55
507	FHIFV_D1	0.8	0.0	2.5	0.3	8	-7.2	-5.5	-10	40	-25	55
508	IFV-HRV	10.1	0.0	11.1	0.0	9	1.1	2.1	-10	40	-25	55
509	IFV-WEV	10.4	0.0	11.5	0.0	9	1.4	2.5	-10	40	-25	55
510	WOV-WEV	9.1	0.0	10.0	0.0	9	0.1	1.0	-10	40	-25	55
511	HRV-HRH	12.2	0.0	14.3	0.0	9	3.2	5.3	-10	40	-25	55
621	FHWOH_D1 BASEPLATE	8.2	1.5	8.2	1.5	0	8.2c.l	8.2c.l	5	15	-25	55
660706	Internal Rad -Y under foot	3.5	0.0	3.5	0.0	0	3.5c.l	3.5c.l	0	10	-25	55
622	FHWEH_D1	10.5	25.7	11.6	25.7	7.8	2.7	3.8	0	30	-25	55
623	FHHRH_D1	19.9	66.3	21.3	66.3	8.8	11.1	12.5	-10	40	-25	55
624	FHLCU_D1	16.7	37.6	21.8	43.4	8	8.7	13.8	-10	40	-25	55
625	FHLSU_D1	18.9	35.8	22.7	40.4	8	10.9	14.7	10	40	-25	55
606	FHIFH_D1	6.2	0.3	9.1	0.3	8	-1.8	1.1	-10	40	-25	55
607	IFH-HRH	12.5	0.0	15.0	0.0	9	3.5	6.0	-10	40	-25	55
608	IFH-WEH	12.8	0.0	15.3	0.0	9	3.8	6.3	-10	40	-25	55
609	WEH-WOH	14.1	0.0	16.7	0.0	9	5.1	7.7	-10	40	-25	55
701	RWL1	1.0	5.0	1.0	5.0	0	1.0h	1.0h	0	55	-10	65
702	RWL2	1.0	5.0	1.0	5.0	0	1.0h	1.0h	0	55	-10	65
703	RWL3	1.0	5.0	1.0	5.0	0	1.0h	1.0h	0	55	-10	65
704	RWL4	1.0	5.0	1.0	5.0	0	1.0h	1.0h	0	55	-10	65
8133	FCV BODY MAIN	14.4	0.0	14.4	0.0	0	14.4h	14.4h	10	60	10	60
8233	FCV BODY MAIN	12.7	0.0	12.7	0.0	0	12.7h	12.7h	10	60	10	60
8333	FCV BODY MAIN	11.0	0.0	11.0	0.0	0	11.0h	11.0h	10	60	10	60
8433	FCV BODY MAIN	11.0	0.0	11.0	0.0	0	11.0h	11.0h	10	60	10	60
8533	FCV BODY MAIN	11.0	0.0	11.3	0.0	0	11.0h	11.3h	10	60	10	60
8633	FCV BODY MAIN	12.2	0.0	12.5	0.0	0	12.2h	12.5h	10	60	10	60
8134	FCV BODY REDUNDANT	14.4	0.0	14.4	0.0	0	14.4h	14.4h	10	60	10	60
8234	FCV BODY REDUNDANT	13.1	0.0	13.2	0.0	0	13.1h	13.2h	10	60	10	60
8334	FCV BODY REDUNDANT	11.0	0.0	11.0	0.0	0	11.0h	11.0h	10	60	10	60
8434	FCV BODY REDUNDANT	11.0	0.0	11.0	0.0	0	11.0h	11.0h	10	60	10	60
8534	FCV BODY REDUNDANT	11.0	0.0	11.6	0.0	0	11.0h	11.6h	10	60	10	60
8634	FCV BODY REDUNDANT	11.9	0.0	12.2	0.0	0	11.9h	12.2h	10	60	10	60
80029	STR1+X FOOT	10.8	0.0	10.8	0.0	0	10.8h	10.8h	-20	40	-30	50
81029	STR2+X FOOT	-5.6	0.0	-5.6	0.0	3.8	-9.4	-9.4	-20	40	-30	50
1501	RCS #9 - LINE 1	28.9	0.0	28.9	0.0	8	20.9	20.9	10	50	10	50
1502	RCS #9 - LINE 1	28.9	0.0	28.9	0.0	8	20.9	20.9	10	50	10	50



Controlled Distribution



REFERENCE : H-P-RP-AI-0040

DATE : 29/SEP/06

ISSUE : 06

Page : 176/405

NODE	LABEL	TEMPERATURE RESULTS AND LIMITS										
		G	G	H	H	UFP	G	H	MIN OPER.	MAX OPER.	MIN N.OPER	MAX N.OPER
		TEMP [°C]	PW [W]	TEMP [°C]	PW [W]		TEMP-UFP [°C]	TEMP-UFP [°C]				
1503	RCS #9 - LINE 1	28.9	0.0	28.9	0.0	8	20.9	20.9	10	50	10	50
1504	RCS #9 - LINE 1	28.9	0.0	28.9	0.0	8	20.9	20.9	10	50	10	50
1505	RCS #9 - LINE 1	28.9	0.0	28.9	0.0	8	20.9	20.9	10	50	10	50
1506	RCS #9 - LINE 1	22.9	0.0	22.9	0.0	8	14.9	14.9	10	50	10	50
1507	RCS #9 - LINE 1	32.7	0.0	32.5	0.0	8	24.7	24.5	10	50	10	50
1508	RCS #9 - LINE 1	23.1	0.0	23.1	0.0	8	15.1	15.1	10	50	10	50
1509	RCS #9 - LINE 1	21.8	0.0	21.8	0.0	8	13.8	13.8	10	50	10	50
1512	RCS #9 - LINE 1	20.4	0.0	20.4	0.0	8	12.4	12.4	10	50	10	50
1513	RCS #9 - LINE 1	30.0	0.0	29.9	0.0	8	22.0	21.9	10	50	10	50
1514	RCS #9 - LINE 1	24.4	0.0	24.3	0.0	8	16.4	16.3	10	50	10	50
1515	RCS #9 - LINE 1	22.8	0.0	22.7	0.0	8	14.8	14.7	10	50	10	50
1516	RCS #9 - LINE 1	24.9	0.0	24.9	0.0	8	16.9	16.9	10	50	10	50
1517	RCS #9 - LINE 1	24.3	0.0	24.2	0.0	8	16.3	16.2	10	50	10	50
1518	RCS #9 - LINE 1	23.0	0.0	23.0	0.0	8	15.0	15.0	10	50	10	50
1519	RCS #9 - LINE 1	22.4	0.0	22.4	0.0	8	14.4	14.4	10	50	10	50
1520	RCS #9 - LINE 1	24.8	0.0	24.8	0.0	8	16.8	16.8	10	50	10	50
1522	RCS #9 - LINE 1	29.8	0.0	29.8	0.0	8	21.8	21.8	10	50	10	50
1523	RCS #9 - LINE 1	23.6	0.0	23.6	0.0	8	15.6	15.6	10	50	10	50
1524	RCS #11 - LINE 2	20.4	0.0	20.4	0.0	8	12.4	12.4	10	50	10	50
1525	RCS #11 - LINE 2	20.4	0.0	20.3	0.0	8	12.4	12.3	10	50	10	50
1526	RCS #11 - LINE 2	20.9	0.0	20.8	0.0	8	12.9	12.8	10	50	10	50
1527	RCS #11 - LINE 2	21.0	0.0	21.0	0.0	8	13.0	13.0	10	50	10	50
1528	RCS #11 - LINE 2	21.0	0.0	21.0	0.0	8	13.0	13.0	10	50	10	50
1529	RCS #11 - LINE 2	23.0	0.0	23.0	0.0	8	15.0	15.0	10	50	10	50
1530	RCS #11 - LINE 2	23.0	0.0	23.0	0.0	8	15.0	15.0	10	50	10	50
1531	RCS #11 - LINE 2	21.4	0.0	21.4	0.0	8	13.4	13.4	10	50	10	50
1532	RCS #11 - LINE 2	20.3	0.0	20.2	0.0	8	12.3	12.2	10	50	10	50
1533	RCS #11 - LINE 2	24.3	0.0	24.2	0.0	8	16.3	16.2	10	50	10	50
1534	RCS #11 - LINE 2	24.3	0.0	24.2	0.0	8	16.3	16.2	10	50	10	50
1535	RCS #11 - LINE 2	24.3	0.0	24.2	0.0	8	16.3	16.2	10	50	10	50
1536	RCS #11 - LINE 2	24.3	0.0	24.2	0.0	8	16.3	16.2	10	50	10	50
1537	RCS #11 - LINE 2	22.9	0.0	22.8	0.0	8	14.9	14.8	10	50	10	50
1538	RCS #11 - LINE 2	29.2	0.0	29.2	0.0	8	21.2	21.2	10	50	10	50
1539	RCS #11 - LINE 2	22.1	0.0	22.0	0.0	8	14.1	14.0	10	50	10	50
1540	RCS #11 - LINE 2	22.1	0.0	22.0	0.0	8	14.1	14.0	10	50	10	50
1541	RCS #11 - LINE 2	21.1	0.0	21.0	0.0	8	13.1	13.0	10	50	10	50
1542	RCS #11 - LINE 2	22.1	0.0	22.0	0.0	8	14.1	14.0	10	50	10	50
1543	RCS #11 - LINE 2	22.5	0.0	22.4	0.0	9	13.5	13.4	10	50	10	50
1544	RCS #11 - LINE 2	21.2	0.0	21.2	0.0	8	13.2	13.2	10	50	10	50
1545	RCS #11 - LINE 2	21.2	0.0	21.2	0.0	8	13.2	13.2	10	50	10	50
1546	RCS #11 - LINE 2	21.2	0.0	21.2	0.0	8	13.2	13.2	10	50	10	50
1547	RCS #11 - LINE 2	21.2	0.0	21.2	0.0	8	13.2	13.2	10	50	10	50
1548	RCS #11 - LINE 2	25.2	0.0	25.1	0.0	8	17.2	17.1	10	50	10	50
1549	RCS #11 - LINE 2	20.9	0.0	20.9	0.0	8	12.9	12.9	10	50	10	50
1550	RCS #11 - LINE 2	20.9	0.0	20.9	0.0	8	12.9	12.9	10	50	10	50
1551	RCS #35 - LINE 3a	23.7	0.0	23.7	0.0	8	15.7	15.7	10	50	10	50
1552	RCS #35 - LINE 3a	23.7	0.0	23.7	0.0	8	15.7	15.7	10	50	10	50
1553	RCS #35 - LINE 3a	23.7	0.0	23.7	0.0	8	15.7	15.7	10	50	10	50
1554	RCS #35 - LINE 3a	23.7	0.0	23.7	0.0	8	15.7	15.7	10	50	10	50
1555	RCS #35 - LINE 3a	23.7	0.0	23.7	0.0	8	15.7	15.7	10	50	10	50
1556	RCS #35 - LINE 3a	22.9	0.0	22.9	0.0	8	14.9	14.9	10	50	10	50
1557	RCS #35 - LINE 3a	22.9	0.0	22.9	0.0	8	14.9	14.9	10	50	10	50



Controlled Distribution



REFERENCE : H-P-RP-AI-0040

DATE : 29/SEP/06

ISSUE : 06

Page : 177/405

NODE	LABEL	TEMPERATURE RESULTS AND LIMITS										
		G	G	H	H	UFP	G	H	MIN OPER.	MAX OPER.	MIN N.OPER	MAX N.OPER
		TEMP [°C]	PW [W]	TEMP [°C]	PW [W]		TEMP-UFP [°C]	TEMP-UFP [°C]				
1558	RCS #35 - LINE 3a	22.9	0.0	22.9	0.0	8	14.9	14.9	10	50	10	50
1559	RCS #35 - LINE 3a	22.9	0.0	22.9	0.0	8	14.9	14.9	10	50	10	50
1560	RCS #35 - LINE 3a	23.6	0.0	23.6	0.0	8	15.6	15.6	10	50	10	50
1561	RCS #35 - LINE 3a	24.6	0.0	24.5	0.0	8	16.6	16.5	10	50	10	50
1562	RCS #35 - LINE 3a	25.7	0.0	25.6	0.0	8	17.7	17.6	10	50	10	50
1563	RCS #35 - LINE 3a	26.2	0.0	26.1	0.0	8	18.2	18.1	10	50	10	50
1564	RCS #35 - LINE 3a	26.2	0.0	26.1	0.0	8	18.2	18.1	10	50	10	50
1565	RCS #35 - LINE 3a	25.5	0.0	25.4	0.0	8	17.5	17.4	10	50	10	50
1566	RCS #35 - LINE 3a	20.9	0.0	20.8	0.0	8	12.9	12.8	10	50	10	50
1567	RCS #35 - LINE 3a	24.3	0.0	24.2	0.0	8	16.3	16.2	10	50	10	50
1450	RCS#48-3b- LF	24.1	0.0	24.1	0.0	8	16.1	16.1	10	50	10	50
1477	RCS#48-3b- LV1	23.0	0.0	23.0	0.0	8	15.0	15.0	10	50	10	50
1482	RCS#48-3b- LV2	24.1	0.0	24.1	0.0	8	16.1	16.1	10	50	10	50
1487	RCS#48-3b- PT	22.2	0.0	22.1	0.0	8	14.2	14.1	10	50	10	50
1568	RCS #37 - LINE 3c	30.0	0.0	29.9	0.0	8	22.0	21.9	10	50	10	50
1569	RCS #37 - LINE 3c	35.2	0.0	35.1	0.0	8	27.2	27.1	10	50	10	50
1570	RCS #37 - LINE 3c	38.8	0.0	38.6	0.0	8	30.8	30.6	10	50	10	50
1571	RCS #37 - LINE 3c	31.4	0.0	31.3	0.0	8	23.4	23.3	10	50	10	50
1572	RCS #37 - LINE 3c	21.7	0.0	21.7	0.0	8	13.7	13.7	10	50	10	50
1573	RCS #37 - LINE 3c	25.2	0.0	25.2	0.0	8	17.2	17.2	10	50	10	50
1574	RCS #37 - LINE 3c	25.8	0.0	25.8	0.0	8	17.8	17.8	10	50	10	50
1576	RCS #37 - LINE 3c	22.8	0.0	22.7	0.0	8	14.8	14.7	10	50	10	50
1578	RCS #37 - LINE 3c	29.0	0.0	29.0	0.0	8	21.0	21.0	10	50	10	50
1580	RCS #37 - LINE 3c	26.1	0.0	26.1	0.0	8	18.1	18.1	10	50	10	50
1581	RCS #37 - LINE 3c	23.9	0.0	23.9	0.0	8	15.9	15.9	10	50	10	50
1583	RCS #37 - LINE 3c	25.4	0.0	25.4	0.0	8	17.4	17.4	10	50	10	50
1584	RCS #37 - LINE 3c	24.0	0.0	24.0	0.0	8	16.0	16.0	10	50	10	50
1585	RCS #37 - LINE 3c	22.9	0.0	22.9	0.0	8	14.9	14.9	10	50	10	50
1586	RCS #37 - LINE 3c	21.5	0.0	21.5	0.0	8	13.5	13.5	10	50	10	50
1588	RCS #37 - LINE 3c	34.7	0.0	34.7	0.0	8	26.7	26.7	10	50	10	50
1589	RCS #37 - LINE 3c	32.9	0.0	32.9	0.0	8	24.9	24.9	10	50	10	50
1590	RCS #37 - LINE 3c	34.4	0.0	34.5	0.0	8	26.4	26.5	10	50	10	50
1591	RCS #37 - LINE 3c	37.0	0.0	37.0	0.0	8	29.0	29.0	10	50	10	50
1592	RCS #37 - LINE 3c	37.0	0.0	37.0	0.0	8	29.0	29.0	10	50	10	50
1593	RCS #37 - LINE 3c	31.0	0.0	31.1	0.0	8	23.0	23.1	10	50	10	50
1594	RCS #37 - LINE 3c	31.0	0.0	30.6	0.0	8	23.0	22.6	10	50	10	50
1595	RCS #45 - LINE 4	23.2	0.0	23.2	0.0	8	15.2	15.2	10	50	10	50
1596	RCS #45 - LINE 4	23.2	0.0	23.2	0.0	8	15.2	15.2	10	50	10	50
1597	RCS #45 - LINE 4	23.2	0.0	23.2	0.0	8	15.2	15.2	10	50	10	50
1598	RCS #45 - LINE 4	23.2	0.0	23.2	0.0	8	15.2	15.2	10	50	10	50
1599	RCS #45 - LINE 4	23.2	0.0	23.2	0.0	8	15.2	15.2	10	50	10	50
1400	RCS #45 - LINE 4	22.9	0.0	22.9	0.0	8	14.9	14.9	10	50	10	50
1401	RCS #45 - LINE 4	22.9	0.0	22.9	0.0	8	14.9	14.9	10	50	10	50
1402	RCS #45 - LINE 4	22.9	0.0	22.9	0.0	8	14.9	14.9	10	50	10	50
1403	RCS #45 - LINE 4	22.9	0.0	22.9	0.0	8	14.9	14.9	10	50	10	50
1404	RCS #45 - LINE 4	22.9	0.0	22.9	0.0	8	14.9	14.9	10	50	10	50
1405	RCS #45 - LINE 4	28.2	0.0	28.2	0.0	8	20.2	20.2	10	50	10	50
1406	RCS #45 - LINE 4	28.9	0.0	29.1	0.0	8	20.9	21.1	10	50	10	50
1407	RCS #45 - LINE 4	30.5	0.0	31.1	0.0	8	22.5	23.1	10	50	10	50
1408	RCS #45 - LINE 4	30.5	0.0	31.1	0.0	8	22.5	23.1	10	50	10	50
1409	RCS #45 - LINE 4	30.1	0.0	30.8	0.0	8	22.1	22.8	10	50	10	50
1410	RCS #45 - LINE 4	28.9	0.0	29.5	0.0	8	20.9	21.5	10	50	10	50



Controlled Distribution



REFERENCE : H-P-RP-AI-0040

DATE : 29/SEP/06

ISSUE : 06

Page : 178/405

NODE	LABEL	TEMPERATURE RESULTS AND LIMITS										
		G	G	H	H	UFP [°C]	G	H	MIN OPER. [°C]	MAX OPER. [°C]	MIN N.OPER [°C]	MAX N.OPER [°C]
		TEMP [°C]	PW [W]	TEMP [°C]	PW [W]		TEMP- UFP [°C]	TEMP-UFP [°C]				
1411	RCS #45 - LINE 4	25.5	0.0	25.5	0.0	8	17.5	17.5	10	50	10	50
1412	RCS #46 - LINE 5a	31.6	0.0	31.5	0.0	8	23.6	23.5	10	50	10	50
1413	RCS #46 - LINE 5a	31.6	0.0	31.5	0.0	8	23.6	23.5	10	50	10	50
1414	RCS #46 - LINE 5a	31.6	0.0	31.5	0.0	8	23.6	23.5	10	50	10	50
1415	RCS #46 - LINE 5a	31.6	0.0	31.5	0.0	8	23.6	23.5	10	50	10	50
1416	RCS #46 - LINE 5a	22.9	0.0	22.9	0.0	8	14.9	14.9	10	50	10	50
1417	RCS #46 - LINE 5a	22.9	0.0	22.9	0.0	8	14.9	14.9	10	50	10	50
1418	RCS #46 - LINE 5a	22.9	0.0	22.9	0.0	8	14.9	14.9	10	50	10	50
1419	RCS #46 - LINE 5a	32.1	0.0	31.8	0.0	8	24.1	23.8	10	50	10	50
1421	RCS #46 - LINE 5a	22.9	0.0	22.8	0.0	8	14.9	14.8	10	50	10	50
1422	RCS #46 - LINE 5a	25.3	0.0	25.3	0.0	8	17.3	17.3	10	50	10	50
1423	RCS #46 - LINE 5a	25.3	0.0	25.3	0.0	8	17.3	17.3	10	50	10	50
1424	RCS #46 - LINE 5a	25.3	0.0	25.3	0.0	8	17.3	17.3	10	50	10	50
1425	RCS #46 - LINE 5a	25.3	0.0	25.3	0.0	8	17.3	17.3	10	50	10	50
1426	RCS #47 - LINE 5b	36.2	0.0	36.4	0.0	8	28.2	28.4	10	50	10	50
1427	RCS #47 - LINE 5b	36.2	0.0	36.4	0.0	8	28.2	28.4	10	50	10	50
1428	RCS #47 - LINE 5b	37.0	0.0	37.2	0.0	8	29.0	29.2	10	50	10	50
1429	RCS #47 - LINE 5b	36.5	0.0	36.7	0.0	8	28.5	28.7	10	50	10	50
1430	RCS #47 - LINE 5b	24.8	0.0	25.0	0.0	8	16.8	17.0	10	50	10	50
1431	RCS #47 - LINE 5b	24.8	0.0	25.0	0.0	8	16.8	17.0	10	50	10	50
1432	RCS #47 - LINE 5b	30.8	0.0	31.0	0.0	8	22.8	23.0	10	50	10	50
1433	RCS #47 - LINE 5b	22.2	0.0	22.3	0.0	8	14.2	14.3	10	50	10	50
1434	RCS #47 - LINE 5b	22.2	0.0	22.3	0.0	8	14.2	14.3	10	50	10	50
1435	RCS #47 - LINE 5b	22.2	0.0	22.3	0.0	8	14.2	14.3	10	50	10	50
1437	RCS #47 - LINE 5b	39.0	0.0	39.3	0.0	8	31.0	31.3	10	50	10	50
1438	RCS #47 - LINE 5b	33.3	0.0	33.6	0.0	8	25.3	25.6	10	50	10	50
1439	RCS #47 - LINE 5b	33.3	0.0	33.6	0.0	8	25.3	25.6	10	50	10	50
1440	RCS #47 - LINE 5b	33.4	0.0	33.8	0.0	8	25.4	25.8	10	50	10	50
1441	RCS #47 - LINE 5b	33.5	0.0	33.8	0.0	8	25.5	25.8	10	50	10	50
1442	RCS #47 - LINE 5b	29.6	0.0	29.9	0.0	8	21.6	21.9	10	50	10	50

Note h: Units with dedicated heater control properly sized; their minimum temperature is the analysis temperature without uncertainty. Only on the RCS the uncertainty is applied even when the heater are operating.

Note c.l.: Units with dedicated heater control law

Table 8.4.1-1 HERSCHEL - Units Temperature results: Sizing Case BOL Nominal G and H

NODE	LABEL	TEMPERATURE RESULTS AND LIMITS							
		I	I	UFP [°C]	I	MIN OPER. [°C]	MAX OPER. [°C]	MIN N.OPER [°C]	MAX N.OPER [°C]
		TEMP [°C]	PW [W]		TEMP-UFP [°C]				
4	VMC	8.4	0.0	7.4	1.0	-10	50	-20	60
5	SAS HOUSING +Z	18.9	0.0	8	10.9	-70	80	-80	90
16	MGA+Z SEPTUM	61.8	0.0	12.4	49.4	-150	150	-150	150
21	LGA+Z	57.9	0.0	8	49.9	-150	120	-150	120
41	LGA-Z	-70.5	0.0	8	-78.5	-150	120	-150	120
45	SAS HOUSING -Z	-30.6	0.0	8	-38.6	-70	80	-80	90
49	WINDOW SREM	-18.0	0.0	8	-26.0	-10	50	-45	90



Controlled Distribution



REFERENCE : H-P-RP-AI-0040

DATE : 29/SEP/06

ISSUE : 06

Page : 179/405

NODE	LABEL	TEMPERATURE RESULTS AND LIMITS							
		I	I	UFP	I	MIN OPER.	MAX OPER.	MIN N.OPER	MAX N.OPER
		TEMP [°C]	PW [W]		TEMP-UFP [°C]				
56	AAD HOUSING	48.0	0.0	8	40.0	-70	70	-80	80
70	TANK1	11.0	0.0	0	11.0h	10	45	10	45
71	TANK2	11.0	0.0	0	11.0h	10	45	10	45
81	GYRO_D1	58.4	0.0	8	50.4	-15	65	-25	65
101	RFDN	15.9	11.8	8	7.9	-25	55	-35	65
122	EPC1_D1	21.6	9.0	8	13.6	-20	60	-30	70
123	EPC2_D1	-1.6	0.0	8.2	-9.8	-20	60	-30	70
104	TRANSX1	22.2	23.0	7.6	14.6	-10	45	-20	55
105	TRANSX2	6.4	10.0	8	-1.6	-10	45	-20	55
126	TWTA1_D1	33.8	0.0	7.9	25.9	-20	60	-30	70
127	TWTA2_D1	-1.7	0.0	8.1	-9.8	-20	60	-30	70
146	TWTA1_HEAD_D1	41.1	32.0	7.9	33.2	-20	60	-30	70
147	TWTA2_HEAD_D1	-1.9	0.0	8.1	-10.0	-20	60	-30	70
130	CRS1_D1	48.4	7.1	0	48.4h	0	50	-10	60
131	CRS2_D1	48.4	7.1	0	48.4h	0	50	-10	60
221	PCDU_D1	9.9	63.2	8	1.9	-10	47	-20	57
222	CDMU_D1	8.3	37.7	8	0.3	-10	45	-20	55
223	ACC_D1	11.0	32.1	8	3.0	-10	45	-20	55
204	BATT	1.0	0.0	0	1.0h	0	35	0	35
321	FPSPU1_2_D1	-17.6	0.0	0	-17.6h	-15	45	-30	60
323	FPDPU_D1	-11.7	0.0	0	-11.7h	-15	45	-30	60
324	FPBOLC_D1	-12.5	0.0	0	-12.5h	-15	45	-30	60
325	FPMECDEC_D1	-14.4	0.0	0	-14.4h	-15	45	-30	60
401	CCU	-9.0	5.4	0	-9.0h	-10	40	-20	50
424	HSDCU_D1	-19.6	0.0	8	-27.6	-15	45	-35	60
425	HSDPU_D1	-20.1	0.0	8	-28.1	-15	45	-35	60
426	HSFCU_D1	-21.0	0.0	8	-29.0	-15	45	-35	60
521	FHWOV_D1_BASEPLATE	-7.9	0.0	0	-7.9h	5	15	-25	55
654007	Internal Rad -Y-Z under foot	-9.6	0.0	0	-9.6h	0	10	-25	55
522	FHHRV_D1	-8.6	0.0	0	-8.6h	-10	40	-25	55
523	FHICU_D1	-10.6	0.0	0	-10.6h	-25	40	-30	60
524	FHFUCU_D1	-9.0	0.0	0	-9.0h	-10	40	-25	55
526	FHWEV_D1	-11.7	0.0	0	-11.7h	0	30	-25	55
507	FHIFV_D1	-9.0	0.0	0	-9.0h	-10	40	-25	55
508	IFV-HRV	-9.7	0.0	0	-9.7h	-10	40	-25	55
509	IFV-WEV	-10.2	0.0	0	-10.2h	-10	40	-25	55
510	WOV-WEV	-10.9	0.0	0	-10.9h	-10	40	-25	55
511	HRV-HRH	-6.1	0.0	0	-6.1h	-10	40	-25	55
621	FHWOH_D1_BASEPLATE	-3.6	0.0	0	-3.6h	5	15	-25	55
660706	Internal Rad -Y under foot	-11.2	0.0	0	-11.2h	0	10	-25	55
622	FHWEH_D1	-1.6	0.0	0	-1.6h	0	30	-25	55
623	FHHRH_D1	-11.9	0.0	0	-11.9h	-10	40	-25	55
624	FHLUCU_D1	-9.4	0.0	0	-9.4h	-10	40	-25	55
625	FHLSU_D1	-2.5	0.0	0	-2.5h	10	40	-25	55
606	FHIFH_D1	-2.2	0.0	8	-10.2	-10	40	-25	55
607	IFH-HRH	-5.4	0.0	0	-5.4h	-10	40	-25	55
608	IFH-WEH	-5.2	0.0	0	-5.2h	-10	40	-25	55
609	WEH-W0H	-3.9	0.0	0	-3.9h	-10	40	-25	55
701	RWL1	1.0	0.0	0	1.0h	0	55	-10	65
702	RWL2	3.4	0.0	0	3.4h	0	55	-10	65
703	RWL3	1.0	0.0	0	1.0h	0	55	-10	65
704	RWL4	1.0	0.0	0	1.0h	0	55	-10	65



Controlled Distribution



REFERENCE : H-P-RP-AI-0040

DATE : 29/SEP/06

ISSUE : 06

Page : 180/405

NODE	LABEL	TEMPERATURE RESULTS AND LIMITS							
		I	I	UFP	I	MIN OPER.	MAX OPER.	MIN N.OPER	MAX N.OPER
		TEMP [°C]	PW [W]		TEMP-UFP [°C]				
8133	FCV BODY MAIN	20.7	0.0	0	20.7h	10	60	10	60
8233	FCV BODY MAIN	21.9	0.0	0	21.9h	10	60	10	60
8333	FCV BODY MAIN	14.3	0.0	0	14.3h	10	60	10	60
8433	FCV BODY MAIN	10.9	0.0	0	10.9h	10	60	10	60
8533	FCV BODY MAIN	11.0	0.0	0	11.0h	10	60	10	60
8633	FCV BODY MAIN	17.9	0.0	0	17.9h	10	60	10	60
8134	FCV BODY REDUNDANT	20.3	0.0	0	20.3h	10	60	10	60
8234	FCV BODY REDUNDANT	19.1	0.0	0	19.1h	10	60	10	60
8334	FCV BODY REDUNDANT	11.1	0.0	0	11.1h	10	60	10	60
8434	FCV BODY REDUNDANT	10.9	0.0	0	10.9h	10	60	10	60
8534	FCV BODY REDUNDANT	11.0	0.0	0	11.0h	10	60	10	60
8634	FCV BODY REDUNDANT	15.0	0.0	0	15.0h	10	60	10	60
80029	STR1+X FOOT	-7.8	0.0	0	-7.8h	-20	40	-30	50
81029	STR2+X FOOT	-7.8	0.0	0	-7.8h	-20	40	-30	50
1501	RCS #9 - LINE 1	30.2	0.0	8	22.2	10	50	10	50
1502	RCS #9 - LINE 1	30.2	0.0	8	22.2	10	50	10	50
1503	RCS #9 - LINE 1	30.2	0.0	8	22.2	10	50	10	50
1504	RCS #9 - LINE 1	30.2	0.0	8	22.2	10	50	10	50
1505	RCS #9 - LINE 1	30.2	0.0	8	22.2	10	50	10	50
1506	RCS #9 - LINE 1	22.9	0.0	8	14.9	10	50	10	50
1507	RCS #9 - LINE 1	33.9	0.0	8	25.9	10	50	10	50
1508	RCS #9 - LINE 1	24.7	0.0	8	16.7	10	50	10	50
1509	RCS #9 - LINE 1	21.8	0.0	8	13.8	10	50	10	50
1512	RCS #9 - LINE 1	24.8	0.0	8	16.8	10	50	10	50
1513	RCS #9 - LINE 1	34.2	0.0	8	26.2	10	50	10	50
1514	RCS #9 - LINE 1	28.9	0.0	8	20.9	10	50	10	50
1515	RCS #9 - LINE 1	27.7	0.0	8	19.7	10	50	10	50
1516	RCS #9 - LINE 1	29.3	0.0	8	21.3	10	50	10	50
1517	RCS #9 - LINE 1	29.3	0.0	8	21.3	10	50	10	50
1518	RCS #9 - LINE 1	27.7	0.0	8	19.7	10	50	10	50
1519	RCS #9 - LINE 1	28.4	0.0	8	20.4	10	50	10	50
1520	RCS #9 - LINE 1	26.2	0.0	8	18.2	10	50	10	50
1522	RCS #9 - LINE 1	33.2	0.0	8	25.2	10	50	10	50
1523	RCS #9 - LINE 1	27.4	0.0	8	19.4	10	50	10	50
1524	RCS #11 - LINE 2	27.3	0.0	8	19.3	10	50	10	50
1525	RCS #11 - LINE 2	27.1	0.0	8	19.1	10	50	10	50
1526	RCS #11 - LINE 2	27.5	0.0	8	19.5	10	50	10	50
1527	RCS #11 - LINE 2	27.3	0.0	8	19.3	10	50	10	50
1528	RCS #11 - LINE 2	27.3	0.0	8	19.3	10	50	10	50
1529	RCS #11 - LINE 2	23.9	0.0	8	15.9	10	50	10	50
1530	RCS #11 - LINE 2	23.9	0.0	8	15.9	10	50	10	50
1531	RCS #11 - LINE 2	22.5	0.0	8	14.5	10	50	10	50
1532	RCS #11 - LINE 2	22.1	0.0	8	14.1	10	50	10	50
1533	RCS #11 - LINE 2	32.1	0.0	8	24.1	10	50	10	50
1534	RCS #11 - LINE 2	32.1	0.0	8	24.1	10	50	10	50
1535	RCS #11 - LINE 2	32.1	0.0	8	24.1	10	50	10	50
1536	RCS #11 - LINE 2	32.1	0.0	8	24.1	10	50	10	50
1537	RCS #11 - LINE 2	30.2	0.0	8	22.2	10	50	10	50
1538	RCS #11 - LINE 2	35.0	0.0	8	27.0	10	50	10	50
1539	RCS #11 - LINE 2	28.3	0.0	8	20.3	10	50	10	50
1540	RCS #11 - LINE 2	28.3	0.0	8	20.3	10	50	10	50
1541	RCS #11 - LINE 2	27.6	0.0	8	19.6	10	50	10	50



Controlled Distribution



REFERENCE : H-P-RP-AI-0040

DATE : 29/SEP/06

ISSUE : 06

Page : 181/405

NODE	LABEL	TEMPERATURE RESULTS AND LIMITS							
		I	I	UFP	I	MIN OPER.	MAX OPER.	MIN N.OPER	MAX N.OPER
		TEMP [°C]	PW [W]		TEMP-UFP [°C]				
1542	RCS #11 - LINE 2	30.7	0.0	8	22.7	10	50	10	50
1543	RCS #11 - LINE 2	32.6	0.0	9	23.6	10	50	10	50
1544	RCS #11 - LINE 2	23.1	0.0	8	15.1	10	50	10	50
1545	RCS #11 - LINE 2	23.1	0.0	8	15.1	10	50	10	50
1546	RCS #11 - LINE 2	23.1	0.0	8	15.1	10	50	10	50
1547	RCS #11 - LINE 2	23.1	0.0	8	15.1	10	50	10	50
1548	RCS #11 - LINE 2	28.7	0.0	8	20.7	10	50	10	50
1549	RCS #11 - LINE 2	23.6	0.0	8	15.6	10	50	10	50
1550	RCS #11 - LINE 2	23.6	0.0	8	15.6	10	50	10	50
1551	RCS #35 - LINE 3a	21.8	0.0	8	13.8	10	50	10	50
1552	RCS #35 - LINE 3a	21.8	0.0	8	13.8	10	50	10	50
1553	RCS #35 - LINE 3a	21.8	0.0	8	13.8	10	50	10	50
1554	RCS #35 - LINE 3a	21.8	0.0	8	13.8	10	50	10	50
1555	RCS #35 - LINE 3a	21.8	0.0	8	13.8	10	50	10	50
1556	RCS #35 - LINE 3a	20.4	0.0	8	12.4	10	50	10	50
1557	RCS #35 - LINE 3a	20.4	0.0	8	12.4	10	50	10	50
1558	RCS #35 - LINE 3a	20.4	0.0	8	12.4	10	50	10	50
1559	RCS #35 - LINE 3a	20.4	0.0	8	12.4	10	50	10	50
1560	RCS #35 - LINE 3a	21.4	0.0	8	13.4	10	50	10	50
1561	RCS #35 - LINE 3a	23.6	0.0	8	15.6	10	50	10	50
1562	RCS #35 - LINE 3a	27.3	0.0	8	19.3	10	50	10	50
1563	RCS #35 - LINE 3a	29.2	0.0	8	21.2	10	50	10	50
1564	RCS #35 - LINE 3a	29.2	0.0	8	21.2	10	50	10	50
1565	RCS #35 - LINE 3a	28.7	0.0	8	20.7	10	50	10	50
1566	RCS #35 - LINE 3a	24.6	0.0	8	16.6	10	50	10	50
1567	RCS #35 - LINE 3a	29.5	0.0	8	21.5	10	50	10	50
1450	RCS#48-3b- LF	21.5	0.0	8	13.5	10	50	10	50
1477	RCS#48-3b- LV1	23.0	0.0	8	15.0	10	50	10	50
1482	RCS#48-3b- LV2	19.5	0.0	8	11.5	10	50	10	50
1487	RCS#48-3b- PT	28.5	0.0	8	20.5	10	50	10	50
1568	RCS #37 - LINE 3c	33.7	0.0	8	25.7	10	50	10	50
1569	RCS #37 - LINE 3c	42.3	0.0	8	34.3	10	50	10	50
1570	RCS #37 - LINE 3c	48.7	0.0	8	40.7	10	50	10	50
1571	RCS #37 - LINE 3c	37.8	0.0	8	29.8	10	50	10	50
1572	RCS #37 - LINE 3c	21.6	0.0	8	13.6	10	50	10	50
1573	RCS #37 - LINE 3c	22.0	0.0	8	14.0	10	50	10	50
1574	RCS #37 - LINE 3c	23.8	0.0	8	15.8	10	50	10	50
1576	RCS #37 - LINE 3c	20.9	0.0	8	12.9	10	50	10	50
1578	RCS #37 - LINE 3c	30.8	0.0	8	22.8	10	50	10	50
1580	RCS #37 - LINE 3c	27.2	0.0	8	19.2	10	50	10	50
1581	RCS #37 - LINE 3c	14.6	0.0	8	6.6	10	50	10	50
1583	RCS #37 - LINE 3c	20.5	0.0	8	12.5	10	50	10	50
1584	RCS #37 - LINE 3c	16.8	0.0	8	8.8	10	50	10	50
1585	RCS #37 - LINE 3c	16.6	0.0	8	8.6	10	50	10	50
1586	RCS #37 - LINE 3c	15.1	0.0	8	7.1	10	50	10	50
1588	RCS #37 - LINE 3c	41.9	0.0	8	33.9	10	50	10	50
1589	RCS #37 - LINE 3c	40.8	0.0	8	32.8	10	50	10	50
1590	RCS #37 - LINE 3c	39.8	0.0	8	31.8	10	50	10	50
1591	RCS #37 - LINE 3c	44.4	0.0	8	36.4	10	50	10	50
1592	RCS #37 - LINE 3c	44.4	0.0	8	36.4	10	50	10	50
1593	RCS #37 - LINE 3c	36.2	0.0	8	28.2	10	50	10	50
1594	RCS #37 - LINE 3c	42.0	0.0	8	34.0	10	50	10	50



Controlled Distribution



REFERENCE : H-P-RP-AI-0040

DATE : 29/SEP/06

ISSUE : 06

Page : 182/405

NODE	LABEL	TEMPERATURE RESULTS AND LIMITS							
		I	I	UFP	I	MIN OPER.	MAX OPER.	MIN N.OPER	MAX N.OPER
		TEMP [°C]	PW [W]		TEMP-UFP [°C]				
1595	RCS #45 - LINE 4	21.9	0.0	8	13.9	10	50	10	50
1596	RCS #45 - LINE 4	21.9	0.0	8	13.9	10	50	10	50
1597	RCS #45 - LINE 4	21.9	0.0	8	13.9	10	50	10	50
1598	RCS #45 - LINE 4	21.9	0.0	8	13.9	10	50	10	50
1599	RCS #45 - LINE 4	21.9	0.0	8	13.9	10	50	10	50
1400	RCS #45 - LINE 4	22.3	0.0	8	14.3	10	50	10	50
1401	RCS #45 - LINE 4	22.3	0.0	8	14.3	10	50	10	50
1402	RCS #45 - LINE 4	22.3	0.0	8	14.3	10	50	10	50
1403	RCS #45 - LINE 4	22.3	0.0	8	14.3	10	50	10	50
1404	RCS #45 - LINE 4	22.3	0.0	8	14.3	10	50	10	50
1405	RCS #45 - LINE 4	28.4	0.0	8	20.4	10	50	10	50
1406	RCS #45 - LINE 4	29.6	0.0	8	21.6	10	50	10	50
1407	RCS #45 - LINE 4	29.8	0.0	8	21.8	10	50	10	50
1408	RCS #45 - LINE 4	29.8	0.0	8	21.8	10	50	10	50
1409	RCS #45 - LINE 4	28.9	0.0	8	20.9	10	50	10	50
1410	RCS #45 - LINE 4	27.3	0.0	8	19.3	10	50	10	50
1411	RCS #45 - LINE 4	32.0	0.0	8	24.0	10	50	10	50
1412	RCS #46 - LINE 5a	31.8	0.0	8	23.8	10	50	10	50
1413	RCS #46 - LINE 5a	31.8	0.0	8	23.8	10	50	10	50
1414	RCS #46 - LINE 5a	31.8	0.0	8	23.8	10	50	10	50
1415	RCS #46 - LINE 5a	31.8	0.0	8	23.8	10	50	10	50
1416	RCS #46 - LINE 5a	22.9	0.0	8	14.9	10	50	10	50
1417	RCS #46 - LINE 5a	22.9	0.0	8	14.9	10	50	10	50
1418	RCS #46 - LINE 5a	22.9	0.0	8	14.9	10	50	10	50
1419	RCS #46 - LINE 5a	34.8	0.0	8	26.8	10	50	10	50
1421	RCS #46 - LINE 5a	24.0	0.0	8	16.0	10	50	10	50
1422	RCS #46 - LINE 5a	23.7	0.0	8	15.7	10	50	10	50
1423	RCS #46 - LINE 5a	23.7	0.0	8	15.7	10	50	10	50
1424	RCS #46 - LINE 5a	23.7	0.0	8	15.7	10	50	10	50
1425	RCS #46 - LINE 5a	23.7	0.0	8	15.7	10	50	10	50
1426	RCS #47 - LINE 5b	36.0	0.0	8	28.0	10	50	10	50
1427	RCS #47 - LINE 5b	36.1	0.0	8	28.1	10	50	10	50
1428	RCS #47 - LINE 5b	37.3	0.0	8	29.3	10	50	10	50
1429	RCS #47 - LINE 5b	36.8	0.0	8	28.8	10	50	10	50
1430	RCS #47 - LINE 5b	27.1	0.0	8	19.1	10	50	10	50
1431	RCS #47 - LINE 5b	27.1	0.0	8	19.1	10	50	10	50
1432	RCS #47 - LINE 5b	31.1	0.0	8	23.1	10	50	10	50
1433	RCS #47 - LINE 5b	22.4	0.0	8	14.4	10	50	10	50
1434	RCS #47 - LINE 5b	22.4	0.0	8	14.4	10	50	10	50
1435	RCS #47 - LINE 5b	22.4	0.0	8	14.4	10	50	10	50
1437	RCS #47 - LINE 5b	37.2	0.0	8	29.2	10	50	10	50
1438	RCS #47 - LINE 5b	31.9	0.0	8	23.9	10	50	10	50
1439	RCS #47 - LINE 5b	31.9	0.0	8	23.9	10	50	10	50
1440	RCS #47 - LINE 5b	31.7	0.0	8	23.7	10	50	10	50
1441	RCS #47 - LINE 5b	34.1	0.0	8	26.1	10	50	10	50
1442	RCS #47 - LINE 5b	34.0	0.0	8	26.0	10	50	10	50

Note h: Units with dedicated heater control properly sized; their minimum temperature is the analysis temperature without uncertainty. Only on the RCS the uncertainty is applied even when the heater are operating.

Table 8.4.1-2 HERSCHEL - Units Temperature results: Sizing Case BOL Survival I



Controlled Distribution



REFERENCE : H-P-RP-AI-0040

DATE : 29/SEP/06

ISSUE : 06

Page : 183/405

NODE	LABEL	TEMPERATURE RESULTS AND LIMITS																
		A		B		C		UFP [°C]	A		B		C		MIN OP [°C]	MAX OP [°C]	MIN N.OP [°C]	MAX N.OP [°C]
		TEMP [°C]	PW [W]	TEMP [°C]	PW [W]	TEMP [°C]	PW [W]		TEMP+ UFP [°C]	TEMP+ UFP [°C]	TEMP+ UFP [°C]	TEMP+ UFP [°C]	TEMP+ UFP [°C]	TEMP+ UFP [°C]				
4	VMC	41.2	0.0	41.9	0.0	41.9	0.0	7.4	48.6	49.3	49.3	-10	50	-20	60			
5	SAS HOUSING +Z	46.4	0.0	46.9	0.0	46.9	0.0	8	54.4	54.9	54.9	-70	80	-80	90			
16	MGA+Z SEPTUM	134.8	0.0	135.1	0.0	135.1	0.0	12.4	147.2	147.5	147.5	-150	150	-150	150			
21	LGA+Z	96.2	0.0	96.3	0.0	96.3	0.0	8	104.2	104.3	104.3	-150	120	-150	120			
41	LGA-Z	-55.1	0.0	-53.5	0.0	-53.2	0.0	8	-47.1	-45.5	-45.2	-150	120	-150	120			
45	SAS HOUSING -Z	1.3	0.0	3.2	0.0	3.6	0.0	8	9.3	11.2	11.6	-70	80	-80	90			
49	WINDOW SREM	25.6	2.6	28.1	2.6	28.5	2.6	8	33.6	36.1	36.5	-10	50	-45	90			
56	AAD HOUSING	63.8	0.0	64.2	0.0	64.2	0.0	8	71.8	72.2	72.2	-70	70	-80	80			
70	TANK1	33.5	0.0	34.7	0.0	34.8	0.0	8	41.5	42.7	42.8	10	45	10	45			
71	TANK2	32.0	0.0	34.1	0.0	34.0	0.0	8	40.0	42.1	42.0	10	45	10	45			
81	GYRO D1	63.3	0.0	63.4	0.0	63.4	0.0	0	63.3h	63.4h	63.4h	-15	65	-25	65			
101	RFDN	40.1	0.0	40.7	0.0	40.7	0.0	8	48.1	48.7	48.7	-25	55	-35	65			
122	EPC1 D1	49.3	0.0	49.8	0.0	49.8	0.0	8	57.3	57.8	57.8	-20	60	-30	70			
123	EPC2 D1	22.0	0.0	22.6	0.0	22.6	0.0	8.2	30.2	30.8	30.8	-20	60	-30	70			
104	TRANSX1	45.1	21.0	45.7	21.0	45.6	21.0	7.6	52.7	53.3	53.2	-10	50	-20	55			
105	TRANSX2	28.4	10.0	29.1	10.0	29.0	10.0	8	36.4	37.1	37.0	-10	45	-20	55			
126	TWTA1 D1	59.5	0.0	60.0	0.0	60.0	0.0	7.9	67.4	67.9	67.9	-20	60	-30	70			
127	TWTA2 D1	23.2	0.0	23.7	0.0	23.7	0.0	8.1	31.3	31.8	31.8	-20	60	-30	70			
146	TWT1 HEAD D1	66.4	0.0	66.9	0.0	66.8	0.0	7.9	74.3	74.8	74.7	-20	60	-30	70			
147	TWT2 HEAD D1	23.0	0.0	23.5	0.0	23.5	0.0	8.1	31.1	31.6	31.6	-20	60	-30	70			
130	CRS1 D1	50.0	7.1	50.0	7.1	50.0	7.1	0	50.0h	50.0h	50.0h	0	50	-10	60			
131	CRS2 D1	50.0	7.1	50.0	7.1	50.0	7.1	0	50.0h	50.0h	50.0h	0	50	-10	60			
221	PCDU D1	30.0	76.5	31.6	76.5	31.3	76.5	8	38.0	39.6	39.3	-10	47	-20	57			
222	CDMU D1	29.4	37.7	32.4	37.7	31.7	37.7	8	37.4	40.4	39.7	-10	45	-20	55			
223	ACC D1	31.2	32.1	34.5	32.1	33.5	32.1	8	39.2	42.5	41.5	-10	45	-20	55			
204	BATT	13.3	2.3	15.2	2.3	14.8	2.3	8	21.3	23.2	22.8	0	35	0	35			
321	FPSPU1 2 D1	26.6	30.3	32.8	33.2	34.8	33.2	8	34.6	40.8	42.8	-15	45	-30	60			
323	FPDPU D1	16.1	14.7	22.3	14.7	24.4	14.7	8	24.1	30.3	32.4	-15	45	-30	60			
324	FPBOLC D1	11.6	6.6	28.1	37.5	17.4	6.6	8	19.6	36.1	25.4	-15	45	-30	60			
325	FPMECDEC D1	15.6	15.9	22.5	19.9	29.6	50.3	8	23.6	30.5	37.6	-15	45	-30	60			
401	CCU	29.6	5.4	31.1	5.4	31.3	5.4	8	37.6	39.1	39.3	-10	40	-20	50			
424	HSDCU D1	30.8	37.0	32.2	37.0	32.3	37.0	8	38.8	40.2	40.3	-15	45	-35	60			
425	HSDPU D1	24.0	15.3	28.0	15.3	29.4	15.3	8	32.0	36.0	37.4	-15	45	-35	60			
426	HSFCU D1	30.0	42.9	33.7	42.9	34.6	42.9	8	38.0	41.7	42.6	-15	45	-35	60			
521	FHWOV D1BASE	8.6	1.5	8.6	1.5	8.6	1.5	0	8.6c.l	8.6c.l	8.6c.l	5	15	-25	55			
654007	Internal Pan -Y-Z under foot	4.6	0.0	4.6	0.0	4.6	0.0	0	4.6c.l	4.6c.l	4.6c.l	0	10	-25	55			
522	FHHRV D1	23.9	66.3	23.3	66.3	23.4	66.3	9	32.9	32.3	32.4	-10	40	-25	55			
523	FHICU D1	21.7	31.4	20.2	29.0	20.3	29.0	8.3	30.0	28.5	28.6	-25	40	-30	60			
524	FHFUCU D1	18.3	13.0	17.9	13.0	17.9	13.0	8	26.3	25.9	25.9	-10	40	-25	55			
526	FHWEV D1	17.1	25.7	16.7	25.7	16.8	25.7	8	25.1	24.7	24.8	0	30	-25	55			
507	FHIFV D1	9.3	0.3	8.0	0.0	8.1	0.0	8	17.3	16.0	16.1	-10	40	-25	55			
508	IFV-HRV	19.4	0.0	18.9	0.0	18.9	0.0	9	28.4	27.9	27.9	-10	40	-25	55			
509	IFV-WEV	19.5	0.0	18.9	0.0	19.0	0.0	9	28.5	27.9	28.0	-10	40	-25	55			
510	WOV-WEV	19.1	0.0	18.8	0.0	18.9	0.0	9	28.1	27.8	27.9	-10	40	-25	55			
511	HRV-HRH	26.2	0.0	24.7	0.0	24.8	0.0	9	35.2	33.7	33.8	-10	40	-25	55			
621	FHWOH D1 BASE	8.0	1.5	8.0	1.5	8.0	1.5	0	8.0c.l	8.0c.l	8.0c.l	5	15	-25	55			
660706	Internal Pan -Y under foot	3.6	0.0	3.6	0.0	3.6	0.0	0	3.6c.l	3.6c.l	3.6c.l	0	10	-25	55			
622	FHWEH D1	22.1	25.7	21.4	25.7	21.4	25.7	7.8	29.9	29.2	29.2	0	30	-25	55			



Controlled Distribution



REFERENCE : H-P-RP-AI-0040

DATE : 29/SEP/06

ISSUE : 06

Page : 184/405

NODE	LABEL	TEMPERATURE RESULTS AND LIMITS													
		A		B		C		UFP [°C]	TEMPERATURE			MIN OP [°C]	MAX OP [°C]	MIN N.OP [°C]	MAX N.OP [°C]
		TEMP [°C]	PW [W]	TEMP [°C]	PW [W]	TEMP [°C]	PW [W]		TEMP +UFP [°C]	TEMP+ UFP [°C]	TEMP+ UFP [°C]				
623	FHHRH D1	30.5	66.3	29.4	66.3	29.5	66.3	8.8	39.3	38.2	38.3	-10	40	-25	55
624	FHLCU D1	31.4	43.4	27.0	37.6	27.0	37.6	8	39.4	35.0	35.0	-10	40	-25	55
625	FHLSU D1	31.7	40.4	28.4	35.8	28.4	35.8	8	39.7	36.4	36.4	10	40	-25	55
606	FHIFH D1	19.2	0.3	16.2	0.0	16.2	0.0	8	27.2	24.2	24.2	-10	40	-25	55
607	IFH-HRH	27.7	0.0	25.8	0.0	25.8	0.0	9	36.7	34.8	34.8	-10	40	-25	55
608	IFH-WEH	27.8	0.0	26.0	0.0	26.0	0.0	9	36.8	35.0	35.0	-10	40	-25	55
609	WEH-WOH	27.6	0.0	25.5	0.0	25.5	0.0	9	36.6	34.5	34.5	-10	40	-25	55
701	RWL1	45.8	25.0	46.3	25.0	46.3	25.0	8	53.8	54.3	54.3	0	55	-10	65
702	RWL2	35.5	10.0	36.0	10.0	36.0	10.0	8	43.5	44.0	44.0	0	55	-10	65
703	RWL3	40.3	15.0	40.9	15.0	40.9	15.0	8	48.3	48.9	48.9	0	55	-10	65
704	RWL4	37.0	10.0	37.4	10.0	37.4	10.0	8	45.0	45.4	45.4	0	55	-10	65
8133	FCV BODY MAIN	46.3	0.0	46.9	0.0	46.9	0.0	8	54.3	54.9	54.9	10	60	10	60
8233	FCV BODY MAIN	38.6	0.0	40.0	0.0	39.8	0.0	8	46.6	48.0	47.8	10	60	10	60
8333	FCV BODY MAIN	37.2	0.0	40.6	0.0	39.7	0.0	8	45.2	48.6	47.7	10	60	10	60
8433	FCV BODY MAIN	34.9	0.0	35.9	0.0	36.0	0.0	8	42.9	43.9	44.0	10	60	10	60
8533	FCV BODY MAIN	39.8	0.0	39.9	0.0	39.9	0.0	8	47.8	47.9	47.9	10	60	10	60
8633	FCV BODY MAIN	42.6	0.0	42.7	0.0	42.7	0.0	8	50.6	50.7	50.7	10	60	10	60
8134	FCV BODY REDUNDANT	46.1	0.0	46.7	0.0	46.7	0.0	8	54.1	54.7	54.7	10	60	10	60
8234	FCV BODY REDUNDANT	38.6	0.0	40.1	0.0	39.8	0.0	8	46.6	48.1	47.8	10	60	10	60
8334	FCV BODY REDUNDANT	37.1	0.0	40.6	0.0	39.6	0.0	8	45.1	48.6	47.6	10	60	10	60
8434	FCV BODY REDUNDANT	35.0	0.0	35.9	0.0	36.0	0.0	8	43.0	43.9	44.0	10	60	10	60
8534	FCV BODY REDUNDANT	40.0	0.0	40.0	0.0	40.1	0.0	8	48.0	48.0	48.1	10	60	10	60
8634	FCV BODY REDUNDANT	42.4	0.0	42.5	0.0	42.6	0.0	8	50.4	50.5	50.6	10	60	10	60
80029	STR1+X FOOT	11.1	0.0	11.1	0.0	11.1	0.0	0	11.1.c.l	11.1.c.l	11.1.c.l	-20	40	-30	50
81029	STR2+X FOOT	-3.4	0.0	-3.4	0.0	-3.4	0.0	3.8	0.4	0.4	0.4	-20	40	-30	50
1501	RCS #9 - LINE 1	40.5	0.0	41.4	0.0	41.4	0.0	8	48.5	49.4	49.4	10	50	10	50
1502	RCS #9 - LINE 1	40.5	0.0	41.4	0.0	41.4	0.0	8	48.5	49.4	49.4	10	50	10	50
1503	RCS #9 - LINE 1	40.5	0.0	41.4	0.0	41.4	0.0	8	48.5	49.4	49.4	10	50	10	50
1504	RCS #9 - LINE 1	40.5	0.0	41.4	0.0	41.4	0.0	8	48.5	49.4	49.4	10	50	10	50
1505	RCS #9 - LINE 1	40.5	0.0	41.4	0.0	41.4	0.0	8	48.5	49.4	49.4	10	50	10	50
1506	RCS #9 - LINE 1	36.3	0.0	37.2	0.0	37.2	0.0	8	44.3	45.2	45.2	10	50	10	50
1507	RCS #9 - LINE 1	40.7	0.0	41.4	0.0	41.4	0.0	8	48.7	49.4	49.4	10	50	10	50
1508	RCS #9 - LINE 1	40.7	0.0	41.4	0.0	41.4	0.0	8	48.7	49.4	49.4	10	50	10	50
1509	RCS #9 - LINE 1	36.3	0.0	37.2	0.0	37.2	0.0	8	44.3	45.2	45.2	10	50	10	50
1512	RCS #9 - LINE 1	38.0	0.0	39.0	0.0	38.9	0.0	8	46.0	47.0	46.9	10	50	10	50
1513	RCS #9 - LINE 1	42.3	0.0	43.0	0.0	43.0	0.0	8	50.3	51.0	51.0	10	50	10	50
1514	RCS #9 - LINE 1	40.8	0.0	41.6	0.0	41.5	0.0	8	48.8	49.6	49.5	10	50	10	50
1515	RCS #9 - LINE 1	40.5	0.0	41.2	0.0	41.2	0.0	8	48.5	49.2	49.2	10	50	10	50
1516	RCS #9 - LINE 1	41.0	0.0	41.7	0.0	41.7	0.0	8	49.0	49.7	49.7	10	50	10	50
1517	RCS #9 - LINE 1	41.5	0.0	42.1	0.0	42.1	0.0	8	49.5	50.1	50.1	10	50	10	50
1518	RCS #9 - LINE 1	43.1	0.0	43.8	0.0	43.7	0.0	8	51.1	51.8	51.7	10	50	10	50
1519	RCS #9 - LINE 1	46.2	0.0	46.8	0.0	46.8	0.0	8	54.2	54.8	54.8	10	50	10	50
1520	RCS #9 - LINE 1	40.5	0.0	41.4	0.0	41.4	0.0	8	48.5	49.4	49.4	10	50	10	50
1522	RCS #9 - LINE 1	43.2	0.0	43.9	0.0	43.8	0.0	8	51.2	51.9	51.8	10	50	10	50
1523	RCS #9 - LINE 1	44.1	0.0	44.7	0.0	44.7	0.0	8	52.1	52.7	52.7	10	50	10	50
1524	RCS #11 - LINE 2	36.6	0.0	37.7	0.0	37.6	0.0	8	44.6	45.7	45.6	10	50	10	50
1525	RCS #11 - LINE 2	36.6	0.0	37.7	0.0	37.6	0.0	8	44.6	45.7	45.6	10	50	10	50
1526	RCS #11 - LINE 2	37.4	0.0	38.5	0.0	38.4	0.0	8	45.4	46.5	46.4	10	50	10	50



Controlled Distribution



REFERENCE : H-P-RP-AI-0040

DATE : 29/SEP/06

ISSUE : 06

Page : 185/405

NODE	LABEL	TEMPERATURE RESULTS AND LIMITS													
		A	A	B	B	C	C	UFP [°C]	A	B	C	MIN OP [°C]	MAX OP [°C]	MIN N.OP [°C]	MAX N.OP [°C]
		TEMP [°C]	PW [W]	TEMP [°C]	PW [W]	TEMP [°C]	PW [W]		TEMP+ UFP [°C]	TEMP+ UFP [°C]	TEMP+ UFP [°C]				
1527	RCS #11 - LINE 2	36.9	0.0	38.1	0.0	38.0	0.0	8	44.9	46.1	46.0	10	50	10	50
1528	RCS #11 - LINE 2	36.9	0.0	38.1	0.0	38.0	0.0	8	44.9	46.1	46.0	10	50	10	50
1529	RCS #11 - LINE 2	32.1	0.0	34.4	0.0	34.1	0.0	8	40.1	42.4	42.1	10	50	10	50
1530	RCS #11 - LINE 2	32.1	0.0	34.4	0.0	34.1	0.0	8	40.1	42.4	42.1	10	50	10	50
1531	RCS #11 - LINE 2	31.5	0.0	33.7	0.0	33.4	0.0	8	39.5	41.7	41.4	10	50	10	50
1532	RCS #11 - LINE 2	32.0	0.0	34.1	0.0	34.0	0.0	8	40.0	42.1	42.0	10	50	10	50
1533	RCS #11 - LINE 2	36.7	0.0	37.8	0.0	37.7	0.0	8	44.7	45.8	45.7	10	50	10	50
1534	RCS #11 - LINE 2	36.7	0.0	37.8	0.0	37.7	0.0	8	44.7	45.8	45.7	10	50	10	50
1535	RCS #11 - LINE 2	36.7	0.0	37.8	0.0	37.7	0.0	8	44.7	45.8	45.7	10	50	10	50
1536	RCS #11 - LINE 2	36.7	0.0	37.8	0.0	37.7	0.0	8	44.7	45.8	45.7	10	50	10	50
1537	RCS #11 - LINE 2	35.6	0.0	36.8	0.0	36.6	0.0	8	43.6	44.8	44.6	10	50	10	50
1538	RCS #11 - LINE 2	34.5	0.0	35.9	0.0	35.6	0.0	8	42.5	43.9	43.6	10	50	10	50
1539	RCS #11 - LINE 2	26.6	0.0	28.0	0.0	27.7	0.0	8	34.6	36.0	35.7	10	50	10	50
1540	RCS #11 - LINE 2	26.6	0.0	28.0	0.0	27.7	0.0	8	34.6	36.0	35.7	10	50	10	50
1541	RCS #11 - LINE 2	26.9	0.0	28.4	0.0	28.1	0.0	8	34.9	36.4	36.1	10	50	10	50
1542	RCS #11 - LINE 2	33.2	0.0	34.2	0.0	34.1	0.0	8	41.2	42.2	42.1	10	50	10	50
1543	RCS #11 - LINE 2	38.6	0.0	40.0	0.0	39.8	0.0	9	47.6	49.0	48.8	10	50	10	50
1544	RCS #11 - LINE 2	31.0	0.0	33.3	0.0	33.0	0.0	8	39.0	41.3	41.0	10	50	10	50
1545	RCS #11 - LINE 2	31.0	0.0	33.3	0.0	33.0	0.0	8	39.0	41.3	41.0	10	50	10	50
1546	RCS #11 - LINE 2	31.0	0.0	33.3	0.0	33.0	0.0	8	39.0	41.3	41.0	10	50	10	50
1547	RCS #11 - LINE 2	31.0	0.0	33.3	0.0	33.0	0.0	8	39.0	41.3	41.0	10	50	10	50
1548	RCS #11 - LINE 2	32.6	0.0	34.7	0.0	34.6	0.0	8	40.6	42.7	42.6	10	50	10	50
1549	RCS #11 - LINE 2	33.6	0.0	35.8	0.0	35.6	0.0	8	41.6	43.8	43.6	10	50	10	50
1550	RCS #11 - LINE 2	33.6	0.0	35.8	0.0	35.6	0.0	8	41.6	43.8	43.6	10	50	10	50
1551	RCS#35 - LINE 3a	28.9	0.0	32.5	0.0	32.8	0.0	8	36.9	40.5	40.8	10	50	10	50
1552	RCS#35 - LINE 3a	28.9	0.0	32.5	0.0	32.8	0.0	8	36.9	40.5	40.8	10	50	10	50
1553	RCS#35 - LINE 3a	28.9	0.0	32.5	0.0	32.8	0.0	8	36.9	40.5	40.8	10	50	10	50
1554	RCS#35 - LINE 3a	28.9	0.0	32.5	0.0	32.8	0.0	8	36.9	40.5	40.8	10	50	10	50
1555	RCS#35 - LINE 3a	28.9	0.0	32.5	0.0	32.8	0.0	8	36.9	40.5	40.8	10	50	10	50
1556	RCS#35 - LINE 3a	26.2	0.0	30.2	0.0	30.5	0.0	8	34.2	38.2	38.5	10	50	10	50
1557	RCS#35 - LINE 3a	26.2	0.0	30.2	0.0	30.5	0.0	8	34.2	38.2	38.5	10	50	10	50
1558	RCS#35 - LINE 3a	26.2	0.0	30.2	0.0	30.5	0.0	8	34.2	38.2	38.5	10	50	10	50
1559	RCS#35 - LINE 3a	26.2	0.0	30.2	0.0	30.5	0.0	8	34.2	38.2	38.5	10	50	10	50
1560	RCS#35 - LINE 3a	26.2	0.0	30.2	0.0	30.5	0.0	8	34.2	38.2	38.5	10	50	10	50
1561	RCS#35 - LINE 3a	25.7	0.0	30.1	0.0	29.9	0.0	8	33.7	38.1	37.9	10	50	10	50
1562	RCS#35 - LINE 3a	25.0	0.0	30.0	0.0	29.0	0.0	8	33.0	38.0	37.0	10	50	10	50
1563	RCS#35 - LINE 3a	23.6	0.0	29.3	0.0	27.3	0.0	8	31.6	37.3	35.3	10	50	10	50
1564	RCS#35 - LINE 3a	23.6	0.0	29.3	0.0	27.3	0.0	8	31.6	37.3	35.3	10	50	10	50
1565	RCS#35 - LINE 3a	24.3	0.0	29.6	0.0	28.0	0.0	8	32.3	37.6	36.0	10	50	10	50
1566	RCS#35 - LINE 3a	22.3	0.0	28.4	0.0	26.4	0.0	8	30.3	36.4	34.4	10	50	10	50
1567	RCS#35 - LINE 3a	37.2	0.0	40.6	0.0	39.7	0.0	8	45.2	48.6	47.7	10	50	10	50
1450	RCS#48-3b- LF	24.5	0.0	27.8	0.0	28.6	0.0	8	32.5	35.8	36.6	10	50	10	50
1477	RCS#48-3b- LV1	25.0	0.0	28.5	0.0	29.2	0.0	8	33.0	36.5	37.2	10	50	10	50
1482	RCS#48-3b- LV2	25.1	0.0	28.3	0.0	29.1	0.0	8	33.1	36.3	37.1	10	50	10	50
1487	RCS#48-3b- PT	19.6	0.0	23.2	0.0	23.9	0.0	8	27.6	31.2	31.9	10	50	10	50
1568	RCS#37 - LINE 3c	27.1	0.0	29.8	0.0	30.2	0.0	8	35.1	37.8	38.2	10	50	10	50
1569	RCS#37 - LINE 3c	27.8	0.0	30.2	0.0	30.5	0.0	8	35.8	38.2	38.5	10	50	10	50
1570	RCS#37 - LINE 3c	30.1	0.0	32.4	0.0	32.7	0.0	8	38.1	40.4	40.7	10	50	10	50
1571	RCS#37 - LINE 3c	30.1	0.0	32.4	0.0	32.7	0.0	8	38.1	40.4	40.7	10	50	10	50
1572	RCS#37 - LINE 3c	27.8	0.0	30.2	0.0	30.5	0.0	8	35.8	38.2	38.5	10	50	10	50
1573	RCS#37 - LINE 3c	25.8	0.0	29.1	0.0	29.7	0.0	8	33.8	37.1	37.7	10	50	10	50



Controlled Distribution



REFERENCE : H-P-RP-AI-0040

DATE : 29/SEP/06

ISSUE : 06

Page : 186/405

NODE	LABEL	TEMPERATURE RESULTS AND LIMITS													
		A	A	B	B	C	C	UFP [°C]	A	B	C	MIN OP [°C]	MAX OP [°C]	MIN N.OP [°C]	MAX N.OP [°C]
		TEMP [°C]	PW [W]	TEMP [°C]	PW [W]	TEMP [°C]	PW [W]		TEMP+ UFP [°C]	TEMP+ UFP [°C]	TEMP+ UFP [°C]				
1574	RCS#37 - LINE 3c	25.3	0.0	28.8	0.0	29.4	0.0	8	33.3	36.8	37.4	10	50	10	50
1576	RCS#37 - LINE 3c	23.9	0.0	27.5	0.0	28.2	0.0	8	31.9	35.5	36.2	10	50	10	50
1578	RCS#37 - LINE 3c	26.0	0.0	29.1	0.0	29.7	0.0	8	34.0	37.1	37.7	10	50	10	50
1580	RCS#37 - LINE 3c	27.1	0.0	29.8	0.0	30.2	0.0	8	35.1	37.8	38.2	10	50	10	50
1581	RCS#37 - LINE 3c	25.8	0.0	28.9	0.0	29.6	0.0	8	33.8	36.9	37.6	10	50	10	50
1583	RCS#37 - LINE 3c	24.5	0.0	27.8	0.0	28.6	0.0	8	32.5	35.8	36.6	10	50	10	50
1584	RCS#37 - LINE 3c	25.1	0.0	28.4	0.0	29.1	0.0	8	33.1	36.4	37.1	10	50	10	50
1585	RCS#37 - LINE 3c	24.5	0.0	27.8	0.0	28.6	0.0	8	32.5	35.8	36.6	10	50	10	50
1586	RCS#37 - LINE 3c	24.0	0.0	27.4	0.0	28.2	0.0	8	32.0	35.4	36.2	10	50	10	50
1588	RCS#37 - LINE 3c	29.7	0.0	31.3	0.0	31.4	0.0	8	37.7	39.3	39.4	10	50	10	50
1589	RCS#37 - LINE 3c	31.7	0.0	33.3	0.0	33.4	0.0	8	39.7	41.3	41.4	10	50	10	50
1590	RCS#37 - LINE 3c	28.1	0.0	29.4	0.0	29.5	0.0	8	36.1	37.4	37.5	10	50	10	50
1591	RCS#37 - LINE 3c	30.4	0.0	31.4	0.0	31.6	0.0	8	38.4	39.4	39.6	10	50	10	50
1592	RCS#37 - LINE 3c	30.4	0.0	31.4	0.0	31.6	0.0	8	38.4	39.4	39.6	10	50	10	50
1593	RCS#37 - LINE 3c	30.8	0.0	31.8	0.0	32.0	0.0	8	38.8	39.8	40.0	10	50	10	50
1594	RCS#37 - LINE 3c	34.9	0.0	35.9	0.0	36.0	0.0	8	42.9	43.9	44.0	10	50	10	50
1595	RCS #45 - LINE 4	29.7	0.0	31.3	0.0	31.4	0.0	8	37.7	39.3	39.4	10	50	10	50
1596	RCS #45 - LINE 4	29.7	0.0	31.3	0.0	31.4	0.0	8	37.7	39.3	39.4	10	50	10	50
1597	RCS #45 - LINE 4	29.7	0.0	31.3	0.0	31.4	0.0	8	37.7	39.3	39.4	10	50	10	50
1598	RCS #45 - LINE 4	29.7	0.0	31.3	0.0	31.4	0.0	8	37.7	39.3	39.4	10	50	10	50
1599	RCS #45 - LINE 4	29.7	0.0	31.3	0.0	31.4	0.0	8	37.7	39.3	39.4	10	50	10	50
1400	RCS #45 - LINE 4	31.8	0.0	33.3	0.0	33.5	0.0	8	39.8	41.3	41.5	10	50	10	50
1401	RCS #45 - LINE 4	31.8	0.0	33.3	0.0	33.5	0.0	8	39.8	41.3	41.5	10	50	10	50
1402	RCS #45 - LINE 4	31.8	0.0	33.3	0.0	33.5	0.0	8	39.8	41.3	41.5	10	50	10	50
1403	RCS #45 - LINE 4	31.8	0.0	33.3	0.0	33.5	0.0	8	39.8	41.3	41.5	10	50	10	50
1404	RCS #45 - LINE 4	31.8	0.0	33.3	0.0	33.5	0.0	8	39.8	41.3	41.5	10	50	10	50
1405	RCS #45 - LINE 4	30.2	0.0	31.4	0.0	31.6	0.0	8	38.2	39.4	39.6	10	50	10	50
1406	RCS #45 - LINE 4	30.7	0.0	31.6	0.0	31.7	0.0	8	38.7	39.6	39.7	10	50	10	50
1407	RCS #45 - LINE 4	28.1	0.0	28.4	0.0	28.5	0.0	8	36.1	36.4	36.5	10	50	10	50
1408	RCS #45 - LINE 4	28.1	0.0	28.4	0.0	28.5	0.0	8	36.1	36.4	36.5	10	50	10	50
1409	RCS #45 - LINE 4	27.4	0.0	27.5	0.0	27.6	0.0	8	35.4	35.5	35.6	10	50	10	50
1410	RCS #45 - LINE 4	27.5	0.0	27.5	0.0	27.6	0.0	8	35.5	35.5	35.6	10	50	10	50
1411	RCS #45 - LINE 4	39.9	0.0	39.9	0.0	40.0	0.0	8	47.9	47.9	48.0	10	50	10	50
1412	RCS#46 - LINE 5a	33.7	0.0	34.7	0.0	34.7	0.0	8	41.7	42.7	42.7	10	50	10	50
1413	RCS#46 - LINE 5a	33.7	0.0	34.7	0.0	34.7	0.0	8	41.7	42.7	42.7	10	50	10	50
1414	RCS#46 - LINE 5a	33.7	0.0	34.7	0.0	34.7	0.0	8	41.7	42.7	42.7	10	50	10	50
1415	RCS#46 - LINE 5a	33.7	0.0	34.7	0.0	34.7	0.0	8	41.7	42.7	42.7	10	50	10	50
1416	RCS#46 - LINE 5a	36.2	0.0	37.1	0.0	37.2	0.0	8	44.2	45.1	45.2	10	50	10	50
1417	RCS#46 - LINE 5a	36.2	0.0	37.1	0.0	37.2	0.0	8	44.2	45.1	45.2	10	50	10	50
1418	RCS#46 - LINE 5a	36.2	0.0	37.1	0.0	37.2	0.0	8	44.2	45.1	45.2	10	50	10	50
1419	RCS#46 - LINE 5a	34.8	0.0	35.9	0.0	36.0	0.0	8	42.8	43.9	44.0	10	50	10	50
1421	RCS#46 - LINE 5a	33.6	0.0	34.8	0.0	34.8	0.0	8	41.6	42.8	42.8	10	50	10	50
1422	RCS#46 - LINE 5a	33.9	0.0	34.8	0.0	34.9	0.0	8	41.9	42.8	42.9	10	50	10	50
1423	RCS#46 - LINE 5a	33.9	0.0	34.8	0.0	34.9	0.0	8	41.9	42.8	42.9	10	50	10	50
1424	RCS#46 - LINE 5a	33.9	0.0	34.8	0.0	34.9	0.0	8	41.9	42.8	42.9	10	50	10	50
1425	RCS#46 - LINE 5a	33.9	0.0	34.8	0.0	34.9	0.0	8	41.9	42.8	42.9	10	50	10	50
1426	RCS#47 - LINE 5b	35.8	0.0	36.7	0.0	36.7	0.0	8	43.8	44.7	44.7	10	50	10	50
1427	RCS#47 - LINE 5b	36.0	0.0	36.9	0.0	36.9	0.0	8	44.0	44.9	44.9	10	50	10	50
1428	RCS#47 - LINE 5b	36.3	0.0	37.2	0.0	37.2	0.0	8	44.3	45.2	45.2	10	50	10	50
1429	RCS#47 - LINE 5b	36.3	0.0	37.2	0.0	37.2	0.0	8	44.3	45.2	45.2	10	50	10	50
1430	RCS#47 - LINE 5b	40.0	0.0	40.8	0.0	40.8	0.0	8	48.0	48.8	48.8	10	50	10	50



Controlled Distribution



REFERENCE : H-P-RP-AI-0040

DATE : 29/SEP/06

ISSUE : 06

Page : 187/405

NODE	LABEL	TEMPERATURE RESULTS AND LIMITS																
		A		B		C		UFP [°C]	A		B		C		MIN OP [°C]	MAX OP [°C]	MIN N.OP [°C]	MAX N.OP [°C]
		TEMP [°C]	PW [W]	TEMP [°C]	PW [W]	TEMP [°C]	PW [W]		TEMP+ UFP [°C]	TEMP+ UFP [°C]	TEMP+ UFP [°C]	TEMP+ UFP [°C]	TEMP+ UFP [°C]	TEMP+ UFP [°C]				
1431	RCS#47 - LINE 5b	40.0	0.0	40.8	0.0	40.8	0.0	8	48.0	48.8	48.8	10	50	10	50			
1432	RCS#47 - LINE 5b	36.3	0.0	37.2	0.0	37.2	0.0	8	44.3	45.2	45.2	10	50	10	50			
1433	RCS#47 - LINE 5b	36.3	0.0	37.2	0.0	37.2	0.0	8	44.3	45.2	45.2	10	50	10	50			
1434	RCS#47 - LINE 5b	36.3	0.0	37.2	0.0	37.2	0.0	8	44.3	45.2	45.2	10	50	10	50			
1435	RCS#47 - LINE 5b	36.3	0.0	37.2	0.0	37.2	0.0	8	44.3	45.2	45.2	10	50	10	50			
1437	RCS#47 - LINE 5b	35.2	0.0	35.8	0.0	35.8	0.0	8	43.2	43.8	43.8	10	50	10	50			
1438	RCS#47 - LINE 5b	33.4	0.0	33.8	0.0	33.9	0.0	8	41.4	41.8	41.9	10	50	10	50			
1439	RCS#47 - LINE 5b	33.4	0.0	33.8	0.0	33.9	0.0	8	41.4	41.8	41.9	10	50	10	50			
1440	RCS#47 - LINE 5b	32.8	0.0	33.1	0.0	33.1	0.0	8	40.8	41.1	41.1	10	50	10	50			
1441	RCS#47 - LINE 5b	35.9	0.0	36.1	0.0	36.2	0.0	8	43.9	44.1	44.2	10	50	10	50			
1442	RCS#47 - LINE 5b	42.5	0.0	42.6	0.0	42.6	0.0	8	50.5	50.6	50.6	10	50	10	50			

Table 8.4.1-3 HERSCHEL - Units Temperature results: Sizing Case EOL Nominal A, B and C

NODE	LABEL	TEMPERATURE RESULTS AND LIMITS																
		D		E		F		UFP [°C]	D		E		F		MIN OPER. [°C]	MAX OPER. [°C]	MIN N.OPER [°C]	MAX N.OPER [°C]
		TEMP [°C]	PW [W]	TEMP [°C]	PW [W]	TEMP [°C]	PW [W]		TEMP+ UFP [°C]	TEMP+ UFP [°C]	TEMP+ UFP [°C]	TEMP+ UFP [°C]	TEMP+ UFP [°C]	TEMP+ UFP [°C]				
4	VMC	41.4	0.0	42.1	0.0	42.1	0.0	7.4	48.8	49.5	49.5	-10	50	-20	60			
5	SAS HOUSING +Z	46.2	0.0	46.7	0.0	46.7	0.0	8	54.2	54.7	54.7	-70	80	-80	90			
16	MGA+Z SEPTUM	134.8	0.0	135.0	0.0	135.0	0.0	12.4	147.2	147.4	147.4	-150	150	-150	150			
21	LGA+Z	96.3	0.0	96.4	0.0	96.4	0.0	8	104.3	104.4	104.4	-150	120	-150	120			
41	LGA-Z	-55.1	0.0	-53.5	0.0	-53.2	0.0	8	-47.1	-45.5	-45.2	-150	120	-150	120			
45	SAS HOUSING -Z	1.3	0.0	3.2	0.0	3.6	0.0	8	9.3	11.2	11.6	-70	80	-80	90			
49	WINDOW SREM	25.6	2.6	28.0	2.6	28.5	2.6	8	33.6	36.0	36.5	-10	50	-45	90			
56	AAD HOUSING	63.7	0.0	64.0	0.0	64.0	0.0	8	71.7	72.0	72.0	-70	70	-80	80			
70	TANK1	33.6	0.0	34.8	0.0	34.9	0.0	8	41.6	42.8	42.9	10	45	10	45			
71	TANK2	31.9	0.0	34.0	0.0	33.9	0.0	8	39.9	42.0	41.9	10	45	10	45			
81	GYRO D1	63.3	0.0	63.4	0.0	63.4	0.0	0	63.3h	63.4h	63.4h	-15	65	-25	65			
101	RFDN	39.6	0.0	40.2	0.0	40.2	0.0	8	47.6	48.2	48.2	-25	55	-35	65			
122	EPC1 D1	48.7	0.0	49.2	0.0	49.2	0.0	8	56.7	57.2	57.2	-20	60	-30	70			
123	EPC2 D1	21.3	0.0	22.0	0.0	21.9	0.0	8.2	29.5	30.2	30.1	-20	60	-30	70			
104	TRANSX1	44.6	21.0	45.2	21.0	45.1	21.0	7.6	52.2	52.8	52.7	-10	50	-20	55			
105	TRANSX2	27.8	10.0	28.5	10.0	28.5	10.0	8	35.8	36.5	36.5	-10	45	-20	55			
126	TWTA1 D1	58.9	0.0	59.4	0.0	59.3	0.0	7.9	66.8	67.3	67.2	-20	60	-30	70			
127	TWTA2 D1	22.5	0.0	23.0	0.0	23.0	0.0	8.1	30.6	31.1	31.1	-20	60	-30	70			
146	TWTA1 HEAD D1	65.8	0.0	66.3	0.0	66.2	0.0	7.9	73.7	74.2	74.1	-20	60	-30	70			
147	TWTA2 HEAD D1	22.3	0.0	22.8	0.0	22.8	0.0	8.1	30.4	30.9	30.9	-20	60	-30	70			
130	CRS1 D1	50.0	7.1	50.0	7.1	50.0	7.1	0	50.0h	50.0h	50.0h	0	50	-10	60			
131	CRS2 D1	50.0	7.1	50.0	7.1	50.0	7.1	0	50.0h	50.0h	50.0h	0	50	-10	60			
221	PCDU D1	29.9	76.5	31.4	76.5	31.1	72.8	8	37.9	39.4	39.1	-10	47	-20	57			
222	CDMU D1	29.2	37.7	32.3	37.7	31.5	37.7	8	37.2	40.3	39.5	-10	45	-20	55			
223	ACC D1	31.1	32.1	34.4	32.1	33.4	32.1	8	39.1	42.4	41.4	-10	45	-20	55			
204	BATT	13.1	2.3	15.0	2.3	14.7	0.0	8	21.1	23.0	22.7	0	35	0	35			
321	FPSPU1_2 D1	26.6	30.3	32.8	33.2	34.7	30.3	8	34.6	40.8	42.7	-15	45	-30	60			
323	FPDPU D1	16.0	14.7	22.3	14.7	24.4	14.7	8	24.0	30.3	32.4	-15	45	-30	60			
324	FPBOLC D1	11.5	6.6	28.1	37.5	17.3	6.6	8	19.5	36.1	25.3	-15	45	-30	60			
325	FPMECDEC D1	15.6	15.9	22.5	19.9	29.6	15.9	8	23.6	30.5	37.6	-15	45	-30	60			



Controlled Distribution



REFERENCE : H-P-RP-AI-0040

DATE : 29/SEP/06

ISSUE : 06

Page : 188/405

NODE	LABEL	TEMPERATURE RESULTS AND LIMITS																
		D		E		F		UFP [°C]	D		E		F		MIN OPER. [°C]	MAX OPER. [°C]	MIN N.OPER [°C]	MAX N.OPER [°C]
		TEMP [°C]	PW [W]	TEMP [°C]	PW [W]	TEMP [°C]	PW [W]		TEMP +UFP [°C]	TEMP +UFP [°C]	TEMP +UFP [°C]							
401	CCU	29.6	5.4	31.1	5.4	31.3	5.4	8	37.6	39.1	39.3	-10	40	-20	50			
424	HSDCU D1	30.9	37.0	32.2	37.0	32.4	37.0	8	38.9	40.2	40.4	-15	45	-35	60			
425	HSDPU D1	23.9	15.3	27.9	15.3	29.3	15.3	8	31.9	35.9	37.3	-15	45	-35	60			
426	HSFCU D1	30.0	42.9	33.6	42.9	34.6	42.9	8	38.0	41.6	42.6	-15	45	-35	60			
521	FHWOV D1_BASE	8.6	1.5	8.6	1.5	8.6	1.5	0	8.6c.l	8.6c.l	8.6c.l	5	15	-25	55			
654007	Internal Rad -Y-Z under foot	4.6	0.0	4.6	0.0	4.6	0.0	0	4.6c.l	4.6c.l	4.6c.l	0	10	-25	55			
522	FHHRV D1	23.9	66.3	23.4	66.3	23.4	66.3	9	32.9	32.4	32.4	-10	40	-25	55			
523	FHICU D1	21.7	31.4	20.2	29.0	20.3	29.0	8.3	30.0	28.5	28.6	-25	40	-30	60			
524	FHFCU D1	18.4	13.0	17.9	13.0	17.9	13.0	8	26.4	25.9	25.9	-10	40	-25	55			
526	FHWEV D1	17.1	25.7	16.7	25.7	16.8	25.7	8	25.1	24.7	24.8	0	30	-25	55			
507	FHIFV D1	9.3	0.3	8.1	0.0	8.1	0.0	8	17.3	16.1	16.1	-10	40	-25	55			
508	IFV-HRV	19.4	0.0	18.9	0.0	19.0	0.0	9	28.4	27.9	28.0	-10	40	-25	55			
509	IFV-WEV	19.5	0.0	18.9	0.0	19.0	0.0	9	28.5	27.9	28.0	-10	40	-25	55			
510	WOV-WEV	19.1	0.0	18.8	0.0	18.9	0.0	9	28.1	27.8	27.9	-10	40	-25	55			
511	HRV-HRH	26.3	0.0	24.8	0.0	24.8	0.0	9	35.3	33.8	33.8	-10	40	-25	55			
621	FHWOH D1_BASEP LATE	8.0	1.5	8.0	1.5	8.0	1.5	0	8.0c.l	8.0c.l	8.0c.l	5	15	-25	55			
660706	Internal Rad -Y under foot	3.6	0.0	3.6	0.0	3.6	0.0	0	3.6c.l	3.6c.l	3.6c.l	0	10	-25	55			
622	FHWEH D1	22.3	25.7	21.5	25.7	21.5	25.7	7.8	30.1	29.3	29.3	0	30	-25	55			
623	FHHRH D1	30.7	66.3	29.6	66.3	29.6	66.3	8.8	39.5	38.4	38.4	-10	40	-25	55			
624	FHLCU D1	31.5	43.4	27.0	37.6	27.1	37.6	8	39.5	35.0	35.1	-10	40	-25	55			
625	FHLSU D1	31.8	40.4	28.5	35.8	28.5	35.8	8	39.8	36.5	36.5	10	40	-25	55			
606	FHIFV D1	19.3	0.3	16.3	0.0	16.3	0.3	8	27.3	24.3	24.3	-10	40	-25	55			
607	IFH-HRH	27.8	0.0	25.9	0.0	25.9	0.0	9	36.8	34.9	34.9	-10	40	-25	55			
608	IFH-WEH	28.0	0.0	26.1	0.0	26.1	0.0	9	37.0	35.1	35.1	-10	40	-25	55			
609	WEH-W0H	27.7	0.0	25.6	0.0	25.6	0.0	9	36.7	34.6	34.6	-10	40	-25	55			
701	RWL1	46.2	25.0	46.7	25.0	46.7	5.0	8	54.2	54.7	54.7	0	55	-10	65			
702	RWL2	35.9	10.0	36.4	10.0	36.4	5.0	8	43.9	44.4	44.4	0	55	-10	65			
703	RWL3	40.7	15.0	41.2	15.0	41.2	5.0	8	48.7	49.2	49.2	0	55	-10	65			
704	RWL4	37.4	10.0	37.8	10.0	37.8	5.0	8	45.4	45.8	45.8	0	55	-10	65			
8133	FCV BODY MAIN	46.2	0.0	46.8	0.0	46.7	0.0	8	54.2	54.8	54.7	10	60	10	60			
8233	FCV BODY MAIN	38.4	0.0	39.8	0.0	39.6	0.0	8	46.4	47.8	47.6	10	60	10	60			
8333	FCV BODY MAIN	37.1	0.0	40.5	0.0	39.6	0.0	8	45.1	48.5	47.6	10	60	10	60			
8433	FCV BODY MAIN	35.0	0.0	35.9	0.0	36.0	0.0	8	43.0	43.9	44.0	10	60	10	60			
8533	FCV BODY MAIN	40.0	0.0	40.0	0.0	40.1	0.0	8	48.0	48.0	48.1	10	60	10	60			
8633	FCV BODY MAIN	42.8	0.0	43.0	0.0	43.0	0.0	8	50.8	51.0	51.0	10	60	10	60			
8134	FCV BODY REDUNDANT	46.0	0.0	46.6	0.0	46.6	0.0	8	54.0	54.6	54.6	10	60	10	60			
8234	FCV BODY REDUNDANT	38.4	0.0	39.9	0.0	39.6	0.0	8	46.4	47.9	47.6	10	60	10	60			
8334	FCV BODY REDUNDANT	37.0	0.0	40.5	0.0	39.5	0.0	8	45.0	48.5	47.5	10	60	10	60			
8434	FCV BODY REDUNDANT	35.0	0.0	35.9	0.0	36.1	0.0	8	43.0	43.9	44.1	10	60	10	60			
8534	FCV BODY REDUNDANT	40.1	0.0	40.1	0.0	40.2	0.0	8	48.1	48.1	48.2	10	60	10	60			
8634	FCV BODY REDUNDANT	42.6	0.0	42.8	0.0	42.8	0.0	8	50.6	50.8	50.8	10	60	10	60			
80029	STR1+X FOOT	11.1	0.0	11.1	0.0	11.1	0.0	0	11.1c.l	11.1c.l	11.1c.l	-20	40	-30	50			
81029	STR2+X FOOT	-3.5	0.0	-3.5	0.0	-3.5	0.0	3.8	0.3	0.3	0.3	-20	40	-30	50			
1501	RCS #9 - LINE 1	40.5	0.0	41.4	0.0	41.4	0.0	8	48.5	49.4	49.4	10	50	10	50			
1502	RCS #9 - LINE 1	40.5	0.0	41.4	0.0	41.4	0.0	8	48.5	49.4	49.4	10	50	10	50			
1503	RCS #9 - LINE 1	40.5	0.0	41.4	0.0	41.4	0.0	8	48.5	49.4	49.4	10	50	10	50			
1504	RCS #9 - LINE 1	40.5	0.0	41.4	0.0	41.4	0.0	8	48.5	49.4	49.4	10	50	10	50			
1505	RCS #9 - LINE 1	40.5	0.0	41.4	0.0	41.4	0.0	8	48.5	49.4	49.4	10	50	10	50			
1506	RCS #9 - LINE 1	36.5	0.0	37.4	0.0	37.4	0.0	8	44.5	45.4	45.4	10	50	10	50			



Controlled Distribution



REFERENCE : H-P-RP-AI-0040

DATE : 29/SEP/06

ISSUE : 06

Page : 189/405

NODE	LABEL	TEMPERATURE RESULTS AND LIMITS													
		D	D	E	E	F	F	UFP [°C]	D	E	F	MIN OPER. [°C]	MAX OPER. [°C]	MIN N.OPER [°C]	MAX N.OPER [°C]
		TEMP [°C]	PW [W]	TEMP [°C]	PW [W]	TEMP [°C]	PW [W]		TEMP +UFP [°C]	TEMP +UFP [°C]	TEMP +UFP [°C]				
1507	RCS #9 - LINE 1	40.9	0.0	41.6	0.0	41.5	0.0	8	48.9	49.6	49.5	10	50	10	50
1508	RCS #9 - LINE 1	40.9	0.0	41.5	0.0	41.5	0.0	8	48.9	49.5	49.5	10	50	10	50
1509	RCS #9 - LINE 1	36.5	0.0	37.3	0.0	37.4	0.0	8	44.5	45.3	45.4	10	50	10	50
1512	RCS #9 - LINE 1	37.8	0.0	38.8	0.0	38.7	0.0	8	45.8	46.8	46.7	10	50	10	50
1513	RCS #9 - LINE 1	42.1	0.0	42.8	0.0	42.8	0.0	8	50.1	50.8	50.8	10	50	10	50
1514	RCS #9 - LINE 1	40.6	0.0	41.4	0.0	41.3	0.0	8	48.6	49.4	49.3	10	50	10	50
1515	RCS #9 - LINE 1	40.3	0.0	41.0	0.0	41.0	0.0	8	48.3	49.0	49.0	10	50	10	50
1516	RCS #9 - LINE 1	40.8	0.0	41.5	0.0	41.5	0.0	8	48.8	49.5	49.5	10	50	10	50
1517	RCS #9 - LINE 1	41.2	0.0	41.9	0.0	41.8	0.0	8	49.2	49.9	49.8	10	50	10	50
1518	RCS #9 - LINE 1	43.0	0.0	43.6	0.0	43.6	0.0	8	51.0	51.6	51.6	10	50	10	50
1519	RCS #9 - LINE 1	46.1	0.0	46.7	0.0	46.6	0.0	8	54.1	54.7	54.6	10	50	10	50
1520	RCS #9 - LINE 1	40.5	0.0	41.4	0.0	41.4	0.0	8	48.5	49.4	49.4	10	50	10	50
1522	RCS #9 - LINE 1	43.0	0.0	43.7	0.0	43.6	0.0	8	51.0	51.7	51.6	10	50	10	50
1523	RCS #9 - LINE 1	43.9	0.0	44.5	0.0	44.5	0.0	8	51.9	52.5	52.5	10	50	10	50
1524	RCS #11 - LINE 2	36.4	0.0	37.5	0.0	37.4	0.0	8	44.4	45.5	45.4	10	50	10	50
1525	RCS #11 - LINE 2	36.4	0.0	37.5	0.0	37.4	0.0	8	44.4	45.5	45.4	10	50	10	50
1526	RCS #11 - LINE 2	37.2	0.0	38.3	0.0	38.3	0.0	8	45.2	46.3	46.3	10	50	10	50
1527	RCS #11 - LINE 2	36.7	0.0	37.9	0.0	37.8	0.0	8	44.7	45.9	45.8	10	50	10	50
1528	RCS #11 - LINE 2	36.7	0.0	37.9	0.0	37.8	0.0	8	44.7	45.9	45.8	10	50	10	50
1529	RCS #11 - LINE 2	32.0	0.0	34.3	0.0	34.0	0.0	8	40.0	42.3	42.0	10	50	10	50
1530	RCS #11 - LINE 2	32.0	0.0	34.3	0.0	34.0	0.0	8	40.0	42.3	42.0	10	50	10	50
1531	RCS #11 - LINE 2	31.3	0.0	33.6	0.0	33.3	0.0	8	39.3	41.6	41.3	10	50	10	50
1532	RCS #11 - LINE 2	31.9	0.0	34.0	0.0	33.9	0.0	8	39.9	42.0	41.9	10	50	10	50
1533	RCS #11 - LINE 2	36.5	0.0	37.6	0.0	37.5	0.0	8	44.5	45.6	45.5	10	50	10	50
1534	RCS #11 - LINE 2	36.5	0.0	37.6	0.0	37.5	0.0	8	44.5	45.6	45.5	10	50	10	50
1535	RCS #11 - LINE 2	36.5	0.0	37.6	0.0	37.5	0.0	8	44.5	45.6	45.5	10	50	10	50
1536	RCS #11 - LINE 2	36.5	0.0	37.6	0.0	37.5	0.0	8	44.5	45.6	45.5	10	50	10	50
1537	RCS #11 - LINE 2	35.3	0.0	36.5	0.0	36.4	0.0	8	43.3	44.5	44.4	10	50	10	50
1538	RCS #11 - LINE 2	34.3	0.0	35.6	0.0	35.4	0.0	8	42.3	43.6	43.4	10	50	10	50
1539	RCS #11 - LINE 2	26.3	0.0	27.7	0.0	27.4	0.0	8	34.3	35.7	35.4	10	50	10	50
1540	RCS #11 - LINE 2	26.3	0.0	27.7	0.0	27.4	0.0	8	34.3	35.7	35.4	10	50	10	50
1541	RCS #11 - LINE 2	26.6	0.0	28.1	0.0	27.8	0.0	8	34.6	36.1	35.8	10	50	10	50
1542	RCS #11 - LINE 2	32.9	0.0	33.9	0.0	33.7	0.0	8	40.9	41.9	41.7	10	50	10	50
1543	RCS #11 - LINE 2	38.4	0.0	39.9	0.0	39.6	0.0	9	47.4	48.9	48.6	10	50	10	50
1544	RCS #11 - LINE 2	30.9	0.0	33.2	0.0	32.9	0.0	8	38.9	41.2	40.9	10	50	10	50
1545	RCS #11 - LINE 2	30.9	0.0	33.2	0.0	32.9	0.0	8	38.9	41.2	40.9	10	50	10	50
1546	RCS #11 - LINE 2	30.9	0.0	33.2	0.0	32.9	0.0	8	38.9	41.2	40.9	10	50	10	50
1547	RCS #11 - LINE 2	30.9	0.0	33.2	0.0	32.9	0.0	8	38.9	41.2	40.9	10	50	10	50
1548	RCS #11 - LINE 2	32.5	0.0	34.6	0.0	34.5	0.0	8	40.5	42.6	42.5	10	50	10	50
1549	RCS #11 - LINE 2	33.5	0.0	35.7	0.0	35.4	0.0	8	41.5	43.7	43.4	10	50	10	50
1550	RCS #11 - LINE 2	33.5	0.0	35.7	0.0	35.4	0.0	8	41.5	43.7	43.4	10	50	10	50
1551	RCS #35 - LINE 3a	28.9	0.0	32.5	0.0	32.7	0.0	8	36.9	40.5	40.7	10	50	10	50
1552	RCS #35 - LINE 3a	28.9	0.0	32.5	0.0	32.7	0.0	8	36.9	40.5	40.7	10	50	10	50
1553	RCS #35 - LINE 3a	28.9	0.0	32.5	0.0	32.7	0.0	8	36.9	40.5	40.7	10	50	10	50
1554	RCS #35 - LINE 3a	28.9	0.0	32.5	0.0	32.7	0.0	8	36.9	40.5	40.7	10	50	10	50
1555	RCS #35 - LINE 3a	28.9	0.0	32.5	0.0	32.7	0.0	8	36.9	40.5	40.7	10	50	10	50
1556	RCS #35 - LINE 3a	26.2	0.0	30.1	0.0	30.5	0.0	8	34.2	38.1	38.5	10	50	10	50
1557	RCS #35 - LINE 3a	26.2	0.0	30.1	0.0	30.5	0.0	8	34.2	38.1	38.5	10	50	10	50
1558	RCS #35 - LINE 3a	26.2	0.0	30.1	0.0	30.5	0.0	8	34.2	38.1	38.5	10	50	10	50
1559	RCS #35 - LINE 3a	26.2	0.0	30.1	0.0	30.5	0.0	8	34.2	38.1	38.5	10	50	10	50
1560	RCS #35 - LINE 3a	26.2	0.0	30.1	0.0	30.5	0.0	8	34.2	38.1	38.5	10	50	10	50



Controlled Distribution



REFERENCE : H-P-RP-AI-0040

DATE : 29/SEP/06

ISSUE : 06

Page : 190/405

NODE	LABEL	TEMPERATURE RESULTS AND LIMITS													
		D	D	E	E	F	F	UFP [°C]	D	E	F	MIN OPER. [°C]	MAX OPER. [°C]	MIN N.OPER [°C]	MAX N.OPER [°C]
		TEMP [°C]	PW [W]	TEMP [°C]	PW [W]	TEMP [°C]	PW [W]		TEMP +UFP [°C]	TEMP +UFP [°C]	TEMP +UFP [°C]				
1561	RCS #35 - LINE 3a	25.6	0.0	30.0	0.0	29.8	0.0	8	33.6	38.0	37.8	10	50	10	50
1562	RCS #35 - LINE 3a	24.9	0.0	29.9	0.0	28.9	0.0	8	32.9	37.9	36.9	10	50	10	50
1563	RCS #35 - LINE 3a	23.5	0.0	29.2	0.0	27.2	0.0	8	31.5	37.2	35.2	10	50	10	50
1564	RCS #35 - LINE 3a	23.5	0.0	29.2	0.0	27.2	0.0	8	31.5	37.2	35.2	10	50	10	50
1565	RCS #35 - LINE 3a	24.2	0.0	29.5	0.0	27.9	0.0	8	32.2	37.5	35.9	10	50	10	50
1566	RCS #35 - LINE 3a	22.3	0.0	28.3	0.0	26.4	0.0	8	30.3	36.3	34.4	10	50	10	50
1567	RCS #35 - LINE 3a	37.1	0.0	40.5	0.0	39.6	0.0	8	45.1	48.5	47.6	10	50	10	50
1450	RCS#48-3b- LF	24.5	0.0	27.8	0.0	28.5	0.0	8	32.5	35.8	36.5	10	50	10	50
1477	RCS#48-3b- LV1	24.9	0.0	28.5	0.0	29.1	0.0	8	32.9	36.5	37.1	10	50	10	50
1482	RCS#48-3b- LV2	25.1	0.0	28.3	0.0	29.1	0.0	8	33.1	36.3	37.1	10	50	10	50
1487	RCS#48-3b- PT	19.5	0.0	23.2	0.0	23.9	0.0	8	27.5	31.2	31.9	10	50	10	50
1568	RCS #37 - LINE 3c	27.0	0.0	29.8	0.0	30.2	0.0	8	35.0	37.8	38.2	10	50	10	50
1569	RCS #37 - LINE 3c	27.8	0.0	30.2	0.0	30.5	0.0	8	35.8	38.2	38.5	10	50	10	50
1570	RCS #37 - LINE 3c	30.1	0.0	32.4	0.0	32.7	0.0	8	38.1	40.4	40.7	10	50	10	50
1571	RCS #37 - LINE 3c	30.1	0.0	32.4	0.0	32.7	0.0	8	38.1	40.4	40.7	10	50	10	50
1572	RCS #37 - LINE 3c	27.8	0.0	30.2	0.0	30.5	0.0	8	35.8	38.2	38.5	10	50	10	50
1573	RCS #37 - LINE 3c	25.8	0.0	29.1	0.0	29.7	0.0	8	33.8	37.1	37.7	10	50	10	50
1574	RCS #37 - LINE 3c	25.3	0.0	28.7	0.0	29.4	0.0	8	33.3	36.7	37.4	10	50	10	50
1576	RCS #37 - LINE 3c	23.8	0.0	27.5	0.0	28.2	0.0	8	31.8	35.5	36.2	10	50	10	50
1578	RCS #37 - LINE 3c	26.0	0.0	29.1	0.0	29.7	0.0	8	34.0	37.1	37.7	10	50	10	50
1580	RCS #37 - LINE 3c	27.1	0.0	29.8	0.0	30.2	0.0	8	35.1	37.8	38.2	10	50	10	50
1581	RCS #37 - LINE 3c	25.7	0.0	28.9	0.0	29.6	0.0	8	33.7	36.9	37.6	10	50	10	50
1583	RCS #37 - LINE 3c	24.4	0.0	27.8	0.0	28.5	0.0	8	32.4	35.8	36.5	10	50	10	50
1584	RCS #37 - LINE 3c	25.1	0.0	28.3	0.0	29.1	0.0	8	33.1	36.3	37.1	10	50	10	50
1585	RCS #37 - LINE 3c	24.4	0.0	27.8	0.0	28.5	0.0	8	32.4	35.8	36.5	10	50	10	50
1586	RCS #37 - LINE 3c	24.0	0.0	27.4	0.0	28.2	0.0	8	32.0	35.4	36.2	10	50	10	50
1588	RCS #37 - LINE 3c	29.7	0.0	31.3	0.0	31.4	0.0	8	37.7	39.3	39.4	10	50	10	50
1589	RCS #37 - LINE 3c	31.8	0.0	33.3	0.0	33.5	0.0	8	39.8	41.3	41.5	10	50	10	50
1590	RCS #37 - LINE 3c	28.1	0.0	29.4	0.0	29.6	0.0	8	36.1	37.4	37.6	10	50	10	50
1591	RCS #37 - LINE 3c	30.4	0.0	31.4	0.0	31.6	0.0	8	38.4	39.4	39.6	10	50	10	50
1592	RCS #37 - LINE 3c	30.4	0.0	31.4	0.0	31.6	0.0	8	38.4	39.4	39.6	10	50	10	50
1593	RCS #37 - LINE 3c	30.9	0.0	31.9	0.0	32.0	0.0	8	38.9	39.9	40.0	10	50	10	50
1594	RCS #37 - LINE 3c	35.0	0.0	35.9	0.0	36.1	0.0	8	43.0	43.9	44.1	10	50	10	50
1595	RCS #45 - LINE 4	29.7	0.0	31.3	0.0	31.4	0.0	8	37.7	39.3	39.4	10	50	10	50
1596	RCS #45 - LINE 4	29.7	0.0	31.3	0.0	31.4	0.0	8	37.7	39.3	39.4	10	50	10	50
1597	RCS #45 - LINE 4	29.7	0.0	31.3	0.0	31.4	0.0	8	37.7	39.3	39.4	10	50	10	50
1598	RCS #45 - LINE 4	29.7	0.0	31.3	0.0	31.4	0.0	8	37.7	39.3	39.4	10	50	10	50
1599	RCS #45 - LINE 4	29.7	0.0	31.3	0.0	31.4	0.0	8	37.7	39.3	39.4	10	50	10	50
1400	RCS #45 - LINE 4	31.8	0.0	33.4	0.0	33.5	0.0	8	39.8	41.4	41.5	10	50	10	50
1401	RCS #45 - LINE 4	31.8	0.0	33.4	0.0	33.5	0.0	8	39.8	41.4	41.5	10	50	10	50
1402	RCS #45 - LINE 4	31.8	0.0	33.4	0.0	33.5	0.0	8	39.8	41.4	41.5	10	50	10	50
1403	RCS #45 - LINE 4	31.8	0.0	33.4	0.0	33.5	0.0	8	39.8	41.4	41.5	10	50	10	50
1404	RCS #45 - LINE 4	31.8	0.0	33.4	0.0	33.5	0.0	8	39.8	41.4	41.5	10	50	10	50
1405	RCS #45 - LINE 4	30.2	0.0	31.5	0.0	31.6	0.0	8	38.2	39.5	39.6	10	50	10	50
1406	RCS #45 - LINE 4	30.8	0.0	31.7	0.0	31.8	0.0	8	38.8	39.7	39.8	10	50	10	50
1407	RCS #45 - LINE 4	28.1	0.0	28.5	0.0	28.6	0.0	8	36.1	36.5	36.6	10	50	10	50
1408	RCS #45 - LINE 4	28.1	0.0	28.5	0.0	28.6	0.0	8	36.1	36.5	36.6	10	50	10	50
1409	RCS #45 - LINE 4	27.5	0.0	27.6	0.0	27.7	0.0	8	35.5	35.6	35.7	10	50	10	50
1410	RCS #45 - LINE 4	27.5	0.0	27.5	0.0	27.6	0.0	8	35.5	35.5	35.6	10	50	10	50
1411	RCS #45 - LINE 4	40.0	0.0	40.1	0.0	40.1	0.0	8	48.0	48.1	48.1	10	50	10	50
1412	RCS #46 - LINE 5a	33.8	0.0	34.8	0.0	34.8	0.0	8	41.8	42.8	42.8	10	50	10	50



Controlled Distribution



REFERENCE : H-P-RP-AI-0040

DATE : 29/SEP/06

ISSUE : 06

Page : 191/405

NODE	LABEL	TEMPERATURE RESULTS AND LIMITS													
		D		E		F		UFP [°C]	D	E	F	MIN OPER. [°C]	MAX OPER. [°C]	MIN N.OPER [°C]	MAX N.OPER [°C]
		TEMP [°C]	PW [W]	TEMP [°C]	PW [W]	TEMP [°C]	PW [W]		TEMP +UFP [°C]	TEMP +UFP [°C]	TEMP +UFP [°C]				
1413	RCS #46 - LINE 5a	33.8	0.0	34.8	0.0	34.8	0.0	8	41.8	42.8	42.8	10	50	10	50
1414	RCS #46 - LINE 5a	33.8	0.0	34.8	0.0	34.8	0.0	8	41.8	42.8	42.8	10	50	10	50
1415	RCS #46 - LINE 5a	33.8	0.0	34.8	0.0	34.8	0.0	8	41.8	42.8	42.8	10	50	10	50
1416	RCS #46 - LINE 5a	36.3	0.0	37.2	0.0	37.3	0.0	8	44.3	45.2	45.3	10	50	10	50
1417	RCS #46 - LINE 5a	36.3	0.0	37.2	0.0	37.3	0.0	8	44.3	45.2	45.3	10	50	10	50
1418	RCS #46 - LINE 5a	36.3	0.0	37.2	0.0	37.3	0.0	8	44.3	45.2	45.3	10	50	10	50
1419	RCS #46 - LINE 5a	34.9	0.0	36.0	0.0	36.1	0.0	8	42.9	44.0	44.1	10	50	10	50
1421	RCS #46 - LINE 5a	33.7	0.0	34.8	0.0	34.9	0.0	8	41.7	42.8	42.9	10	50	10	50
1422	RCS #46 - LINE 5a	34.0	0.0	34.9	0.0	35.0	0.0	8	42.0	42.9	43.0	10	50	10	50
1423	RCS #46 - LINE 5a	34.0	0.0	34.9	0.0	35.0	0.0	8	42.0	42.9	43.0	10	50	10	50
1424	RCS #46 - LINE 5a	34.0	0.0	34.9	0.0	35.0	0.0	8	42.0	42.9	43.0	10	50	10	50
1425	RCS #46 - LINE 5a	34.0	0.0	34.9	0.0	35.0	0.0	8	42.0	42.9	43.0	10	50	10	50
1426	RCS #47 - LINE 5b	36.0	0.0	36.9	0.0	36.9	0.0	8	44.0	44.9	44.9	10	50	10	50
1427	RCS #47 - LINE 5b	36.2	0.0	37.0	0.0	37.0	0.0	8	44.2	45.0	45.0	10	50	10	50
1428	RCS #47 - LINE 5b	36.5	0.0	37.4	0.0	37.4	0.0	8	44.5	45.4	45.4	10	50	10	50
1429	RCS #47 - LINE 5b	36.5	0.0	37.4	0.0	37.4	0.0	8	44.5	45.4	45.4	10	50	10	50
1430	RCS #47 - LINE 5b	40.2	0.0	41.0	0.0	41.0	0.0	8	48.2	49.0	49.0	10	50	10	50
1431	RCS #47 - LINE 5b	40.2	0.0	41.0	0.0	41.0	0.0	8	48.2	49.0	49.0	10	50	10	50
1432	RCS #47 - LINE 5b	36.5	0.0	37.4	0.0	37.4	0.0	8	44.5	45.4	45.4	10	50	10	50
1433	RCS #47 - LINE 5b	36.5	0.0	37.4	0.0	37.4	0.0	8	44.5	45.4	45.4	10	50	10	50
1434	RCS #47 - LINE 5b	36.5	0.0	37.4	0.0	37.4	0.0	8	44.5	45.4	45.4	10	50	10	50
1435	RCS #47 - LINE 5b	36.5	0.0	37.4	0.0	37.4	0.0	8	44.5	45.4	45.4	10	50	10	50
1437	RCS #47 - LINE 5b	35.4	0.0	36.0	0.0	36.1	0.0	8	43.4	44.0	44.1	10	50	10	50
1438	RCS #47 - LINE 5b	33.7	0.0	34.1	0.0	34.2	0.0	8	41.7	42.1	42.2	10	50	10	50
1439	RCS #47 - LINE 5b	33.7	0.0	34.1	0.0	34.2	0.0	8	41.7	42.1	42.2	10	50	10	50
1440	RCS #47 - LINE 5b	33.1	0.0	33.3	0.0	33.4	0.0	8	41.1	41.3	41.4	10	50	10	50
1441	RCS #47 - LINE 5b	36.2	0.0	36.4	0.0	36.4	0.0	8	44.2	44.4	44.4	10	50	10	50
1442	RCS #47 - LINE 5b	42.7	0.0	42.9	0.0	42.9	0.0	8	50.7	50.9	50.9	10	50	10	50

Remark:

VMC unit the thermal design has been conceived considering this unit switched-on only up to the end of transfer orbit. In this condition the unit works correctly within the requested limits.

If the unit will be requested to be operative during the rest of the mission the hot case temperature reaches about 57°C (in EOL cases) vs 50°C of maximum operative limit.

Table 8.4.1-4 HERSCHEL - Units Temperature results: Sizing Case EOL Nominal D, E and F



8.4.2 Transient Cases with Attitude Change Results

Transient analysis cases were run to assess the thermal behaviour of the SVM when subjected to attitude change (sun from +30 deg to -30 deg on -X side and vice-versa). Main purpose was to verify the capability of the design to meet the stability requirements. Considerations about the stability are reported in [AD23]. Purpose of this paragraph is to report the temperature level reach from the units during the attitude change in terms of minimum and maximum temperature (Table 8.4.2-1). A complete vision of the results is reported in [AD24].

NODE	LABEL	P		Q	
		T MIN [°C]	T MAX [°C]	T MIN [°C]	T MAX [°C]
4	VMC	6.6	23.6	16.4	37.8
5	SAS HOUSING +Z	20.4	33.8	27.5	43.1
16	MGA+Z SEPTUM	55.1	112.7	63.0	121.4
21	LGA+Z	33.1	60.0	40.7	68.8
41	LGA-Z	-64.4	-58.1	-63.5	-55.7
45	SAS HOUSING -Z	-16.1	-4.1	-14.4	0.2
49	WINDOW SREM	4.7	18.9	6.8	24.2
56	AAD HOUSING	46.2	54.4	50.9	60.8
70	TANK1	11.5	21.7	11.0	31.1
71	TANK2	11.0	21.7	12.3	29.4
81	GYRO D1	62.4	63.0	62.5	63.1
101	RFDN	2.1	23.7	10.6	34.0
122	EPC1 D1	0.4	26.7	7.4	36.7
123	EPC2 D1	-9.0	4.2	2.8	17.3
104	TRANSX1	10.8	26.6	18.4	36.8
105	TRANSX2	-0.2	12.0	10.0	23.9
126	TWTA1 D1	1.9	39.5	11.1	49.6
127	TWTA2 D1	-10.7	4.9	1.3	18.4
146	TWTA1 HEAD D1	2.5	46.7	11.7	56.6
147	TWTA2 HEAD D1	-11.0	4.7	1.1	18.2
130	CRS1 D1	48.9	49.5	48.9	49.6
131	CRS2 D1	48.9	49.5	48.9	49.6
221	PCDU D1	13.0	22.2	16.3	28.1
222	CDMU D1	10.6	22.8	12.7	27.8
223	ACC D1	13.3	24.5	15.6	29.6
204	BATT	1.0	4.0	1.1	11.2
321	FPSPU1_2 D1	10.0	21.4	11.6	25.5
323	FPDPU D1	-2.1	10.3	-0.4	14.8
324	FPBOLC D1	-7.6	5.3	-5.7	10.2
325	FPMCEDEC D1	-3.0	9.7	-1.1	14.3
401	CCU	7.7	22.9	9.8	28.3
424	HSDCU D1	11.6	24.7	13.6	29.6



Controlled Distribution

NODE	LABEL	P		Q	
		T MIN [°C]	T MAX [°C]	T MIN [°C]	T MAX [°C]
425	HSDPU D1	5.9	18.1	7.7	22.7
426	HSFCU D1	12.0	24.4	13.7	28.8
521	FHWOV D1 BASE	8.7	9.7	8.6	9.8
522	FHHRV D1	16.9	21.7	17.5	23.5
523	FHICU D1	14.6	19.6	15.2	21.3
524	FHFCU D1	10.3	15.8	11.1	17.8
526	FHWEV D1	11.9	15.4	12.4	16.7
507	FHIFV D1	2.5	7.1	3.2	8.9
508	IFV-HRV	11.2	16.8	11.9	18.8
509	IFV-WEV	11.6	17.0	12.3	19.0
510	WOV-WEV	10.1	16.3	10.9	18.5
511	HRV-HRH	14.4	21.9	15.9	25.4
621	FHWOH D1 BASE	8.0	9.0	8.0	9.2
622	FHWEH D1	11.6	17.6	13.7	21.4
623	FHHRH D1	21.3	26.3	23.2	29.8
624	FHLCU D1	21.8	27.8	23.1	30.7
625	FHLSU D1	22.7	28.1	24.1	31.0
606	FHIFH D1	9.1	15.7	10.4	18.6
607	IFH-HRH	15.0	23.0	16.8	26.8
608	IFH-WEH	15.3	23.1	17.2	27.0
609	WEH-W0H	16.7	23.3	18.5	26.8
701	RWL1	1.0	13.1	25.2	41.5
702	RWL2	1.0	13.3	14.1	32.1
703	RWL3	1.1	14.1	19.0	37.0
704	RWL4	1.0	13.3	14.6	32.3
8133	FCV BODY MAIN	14.5	34.0	20.3	43.0
8233	FCV BODY MAIN	12.8	29.4	15.7	36.3
8333	FCV BODY MAIN	11.0	31.0	11.2	35.8
8433	FCV BODY MAIN	11.0	29.7	11.1	33.9
8533	FCV BODY MAIN	11.3	31.9	14.2	38.5
8633	FCV BODY MAIN	12.5	28.4	19.3	40.1
8134	FCV BODY REDUNDANT	14.5	33.9	20.4	42.8
8234	FCV BODY REDUNDANT	13.2	29.5	16.2	36.3
8334	FCV BODY REDUNDANT	11.0	30.9	11.5	35.7
8434	FCV BODY REDUNDANT	11.0	29.7	11.0	34.0
8534	FCV BODY REDUNDANT	11.6	32.0	14.5	38.6
8634	FCV BODY REDUNDANT	12.2	28.3	18.9	39.9
80029	STR1+X FOOT	10.8	11.1	10.9	11.1
81029	STR2+X FOOT	-5.5	-4.1	-5.5	-3.6

Table 8.4.2-1 HERSCHEL – Transient cases: Min and Max temperatures (without uncertainty)

Controlled Distribution



REFERENCE : H-P-RP-AI-0040

DATE : 29/SEP/06

ISSUE : 06

Page : 194/405

8.4.3 Heater Power Summary

The following tables provide the heater power consumption for the analysis cases performed in transient condition.

HEATER LINE	TCS ID	INSTALLED POWER [W]	HEATER POWER [W]								
			A	B	C	D	E	F	G	H	I
			EOL	EOL	EOL	EOL	EOL	EOL	BOL	BOL	BOL Surv.
TCS Line 27	HTR80027	21.13	0.79	0.74	0.74	0.82	0.78	0.77	9.07	9.07	21.12
TCS Line 14	HTR80052	7.05	2.68	2.67	2.67	2.57	2.56	2.56	4.44	4.44	0
TCS Line 36	HTR81052	7.05	0	0	0	0	0	0	0	0	0
TCS Line 38	HTR100	45.22	9.54	8.71	8.75	9.72	8.89	8.93	38.62	38.54	45
TCS Line 07	HTR130	24.30	7.02	5.99	6.15	7.25	6.22	6.38	23.49	23.44	21.17
TCS Line 49	HTR131	24.30	6.83	5.77	5.92	7.08	6	6.16	24.13	24.11	21.86
TCS Line 01	HTR104	11.39	0	0	0	0	0	0	0	0	0
TCS Line 02	HTR105	11.39	0	0	0	0	0	0	0	0	0
TCS Line 03	HTR204	14.90	0	0	0	0	0	0	10.99	10.93	11.62
TCS Line 06	HTR304	9.40	0	0	0	0	0	0	0	0	9.4
TCS Line 12	HTR501	22.80	4.34	4.42	4.37	4.33	4.41	4.36	12	11.4	17.09
TCS Line 16	HTR601	32.40	4.94	6.74	6.72	4.84	6.63	6.61	16.92	14.76	19.61
TCS Line 23	HTR701	11.39	0	0	0	0	0	0	4.49	4.33	7.53
TCS Line 21	HTR702	11.39	0	0	0	0	0	0	5.15	4.79	11.39
TCS Line 24	HTR703	11.39	0	0	0	0	0	0	4.41	4.23	7.71
TCS Line 22	HTR704	11.39	0	0	0	0	0	0	4.18	3.82	10.8
TCS Line 25	HTR70	6.17	0	0	0	0	0	0	1.5	1.49	2.29
TCS Line 26	HTR71	6.17	0	0	0	0	0	0	1.37	1.36	1.57
TCS Line 29	HTR8133	1.43	0	0	0	0	0	0	0	0	0
TCS Line 39	HTR8134	1.43	0	0	0	0	0	0	0	0	0
TCS Line 30	HTR8233	1.43	0	0	0	0	0	0	0	0	0
TCS Line 40	HTR8234	1.43	0	0	0	0	0	0	0	0	0
TCS Line 31	HTR8333	1.43	0	0	0	0	0	0	0.17	0.16	0
TCS Line 41	HTR8334	1.43	0	0	0	0	0	0	0.13	0.13	0
TCS Line 32	HTR8433	1.43	0	0	0	0	0	0	0.62	0.59	1.28
TCS Line 42	HTR8434	1.43	0	0	0	0	0	0	0.61	0.59	1.27
TCS Line 33	HTR8533	1.43	0	0	0	0	0	0	0.12	0	0.18
TCS Line 43	HTR8534	1.43	0	0	0	0	0	0	0.05	0	0.61
TCS Line 34	HTR8633	1.43	0	0	0	0	0	0	0	0	0
TCS Line 44	HTR8634	1.43	0	0	0	0	0	0	0	0	0
TCS Line 05	HTR301	31.00	0	0	0	0	0	0	0	0	31.02
TCS Line 08	HTR305	27.48	0	0	0	0	0	0	0	0	27.48
TCS Line 10	HTR401	44.50	0	0	0	0	0	0	0	0	8.23



Controlled Distribution



REFERENCE : H-P-RP-AI-0040

DATE : 29/SEP/06

ISSUE : 06

Page : 195/405

HEATER LINE	TCS ID	INSTALLED POWER [W]	HEATER POWER [W]									
			A	B	C	D	E	F	G	H	I	
			EOL	EOL	EOL	EOL	EOL	EOL	BOL	BOL	BOL Surv.	
TCS Line 13	HTR502	39.00	0	0	0	0	0	0	0	0	0	38.98
TCS Line 15	HTR506	35.70	0	0	0	0	0	0	0	0	0	35.69
TCS Line 28	HTR507	11.39	0	0	0	0	0	0	0	0	0	3.41
TCS Line 17	HTR602	32.40	0	0	0	0	0	0	0	0	0	32.4
TCS Line 18	HTR603	39.00	0	0	0	0	0	0	0	0	0	38.98
TCS Line 19	HTR604	20.90	0	0	0	0	0	0	0	0	0	20.9
TCS Line 20	HTR605	29.00	0	0	0	0	0	0	0	0	0	29
TCS Line 09	HTR1523	5.67	0	0	0	0	0	0	0	4.65	4.62	4.61
TCS Line 11	HTR1562	5.54	0	0	0	0	0	0	0	4.79	4.75	5.53
TCS Line 35	HTR1544	5.24	0	0	0	0	0	0	0	4.19	4.16	5.24
TCS Line 48	HTR1550	4.90	0	0	0	0	0	0	0	2.87	2.84	4.89
TCS Line 37	HTR1554	9.35	0	0	0	0	0	0	0	6.3	6.23	9.35
TCS Line 45	HTR1513	5.74	0	0	0	0	0	0	0	4.34	4.26	5.74
TCS Line 46	HTR1506	4.68	0	0	0	0	0	0	0	3.94	3.86	4.6
TCS Line 47	HTR1535	4.82	0	0	0	0	0	0	0	4.82	4.82	4.82
	Total	662.70	36.14	35.04	35.32	36.61	35.49	35.77	198.36	193.72	522.37	

Table 8.4.3-1 HERSCHEL – Average Heater Power Consumption in Nominal Cases



8.4.4 Redundancy Analysis

A series of additional analysis has been performed to verify the temperature behaviour when the redundancy units are activated. In particular the following hot case analyses have been considered:

Transient analysis

- Brid: TT &C activation of line 2 on the hottest case for TT&C and activation of STR2
- C 2 STR ON: two Star Tracker ON on the hottest case for STR to size the Radiator area

The transient case results obtained are showed in Table 8.4.4-1:

NODE	LABEL	TEMPERATURE RESULTS AND LIMITS										
		Brid	Brid	C 2STR ON	C 2STR ON	UFP [°C]	Brid	C 2STR ON	MIN OPER. [°C]	MAX OPER. [°C]	MIN N.OPER [°C]	MAX N.OPER [°C]
		TEMP [°C]	PW [W]	TEMP [°C]	PW [W]		TEMP-UFP [°C]	TEMP-UFP [°C]				
4	VMC	41.9	0.0	42.0	0.0	7.4	49.3	49.4	-10	50	-20	60
5	SAS HOUSING +Z	47.7	0.0	46.9	0.0	8	55.7	54.9	-70	80	-80	90
16	MGA+Z SEPTUM	134.4	0.0	135.1	0.0	12.4	146.8	147.5	-150	150	-150	150
21	LGA+Z	96.3	0.0	96.3	0.0	8	104.3	104.3	-150	120	-150	120
41	LGA-Z	-53.5	0.0	-53.2	0.0	8	-45.5	-45.2	-150	120	-150	120
45	SAS HOUSING -Z	3.2	0.0	3.6	0.0	8	11.2	11.6	-70	80	-80	90
49	WINDOW SREM	28.0	2.6	28.6	2.6	8	36.0	36.6	-10	50	-45	90
56	AAD HOUSING	64.0	0.0	64.2	0.0	8	72.0	72.2	-70	70	-80	80
70	TANK1	34.7	0.0	34.9	0.0	8	42.7	42.9	10	45	10	45
71	TANK2	34.0	0.0	34.0	0.0	8	42.0	42.0	10	45	10	45
81	GYRO_D1	63.4	0.0	63.4	0.0	0	63.4h	63.4h	-15	65	-25	65
101	RFDN	39.7	0.0	40.7	0.0	8	47.7	48.7	-25	55	-35	65
122	EPC1_D1	38.5	0.0	49.8	0.0	8	46.5	57.8	-20	60	-30	70
123	EPC2_D1	32.7	0.0	22.6	0.0	8.2	40.9	30.8	-20	60	-30	70
104	TRANSX1	37.3	10.0	45.7	21.0	7.6	44.9	53.3	-10	50	-20	55
105	TRANSX2	37.6	21.0	29.1	10.0	8	45.6	37.1	-10	45	-20	55
126	TWTA1_D1	42.1	0.0	60.0	0.0	7.9	50.0	67.9	-20	60	-30	70
127	TWTA2_D1	40.0	0.0	23.7	0.0	8.1	48.1	31.8	-20	60	-30	70
146	TWTA1_HEAD_D1	42.2	0.0	66.8	0.0	7.9	50.1	74.7	-20	60	-30	70
147	TWTA2_HEAD_D1	45.9	0.0	23.5	0.0	8.1	54.0	31.6	-20	60	-30	70
130	CRS1_D1	50.0	7.1	50.0	7.1	0	50.0h	50.0h	0	50	-10	60
131	CRS2_D1	50.0	7.1	50.0	7.1	0	50.0h	50.0h	0	50	-10	60
221	PCDU_D1	31.5	76.5	31.3	76.5	8	39.5	39.3	-10	47	-20	57
222	CDMU_D1	32.4	37.7	31.7	37.7	8	40.4	39.7	-10	45	-20	55
223	ACC_D1	34.5	32.1	33.5	32.1	8	42.5	41.5	-10	45	-20	55
204	BATT	15.4	2.3	14.9	2.3	8	23.4	22.9	0	35	0	35
321	FPSPU1_2_D1	32.8	33.2	34.8	33.2	8	40.8	42.8	-15	45	-30	60
323	FPDPU_D1	22.3	14.7	24.5	14.7	8	30.3	32.5	-15	45	-30	60
324	FPBOLC_D1	28.1	37.5	17.5	6.6	8	36.1	25.5	-15	45	-30	60
325	FPMECDEC_D1	22.5	19.9	29.6	50.3	8	30.5	37.6	-15	45	-30	60
401	CCU	31.0	5.4	31.3	5.4	8	39.0	39.3	-10	40	-20	50
424	HSDCU_D1	32.1	37.0	32.4	37.0	8	40.1	40.4	-15	45	-35	60
425	HSDPU_D1	28.0	15.3	29.4	15.3	8	36.0	37.4	-15	45	-35	60
426	HSFCU_D1	33.6	42.9	34.6	42.9	8	41.6	42.6	-15	45	-35	60
521	FHWOV_D1_BASE	8.6	1.5	8.6	1.5	0	8.6c.l	8.6c.l	5	15	-25	55
654007	Internal Rad -Y-Z under foot	4.6	0.0	4.6	0.0	0	4.6c.l	4.6c.l	0	10	-25	55
522	FHHRV_D1	23.3	66.3	23.4	66.3	9	32.3	32.4	32.7	32.2	32.3	-10

Controlled Distribution



REFERENCE : H-P-RP-AI-0040

DATE : 29/SEP/06

ISSUE : 06

Page : 197/405

NODE	LABEL	TEMPERATURE RESULTS AND LIMITS										
		Brid	Brid	C 2STR ON	C 2STR ON	UFP [°C]	Brid	C 2STR ON	MIN OPER. [°C]	MAX OPER. [°C]	MIN N.OPER [°C]	MAX N.OPER [°C]
		TEMP [°C]	PW [W]	TEMP [°C]	PW [W]		TEMP-UFP [°C]	TEMP-UFP [°C]				
523	FHICU_D1	20.2	29.0	20.3	29.0	8.3	28.5	28.6	29.8	28.3	28.4	-25
524	FHFCU_D1	17.9	13.0	17.9	13.0	8	25.9	25.9	26.0	25.6	25.7	-10
526	FHWEV_D1	16.7	25.7	16.8	25.7	8	24.7	24.8	24.1	23.8	23.9	0
507	FHIFV_D1	8.0	0.0	8.1	0.0	8	16.0	16.1	16.7	15.5	15.6	-10
508	IFV-HRV	18.9	0.0	19.0	0.0	9	27.9	28.0	27.8	27.5	27.6	-10
509	IFV-WEV	18.9	0.0	19.0	0.0	9	27.9	28.0	27.9	27.4	27.5	-10
510	WOV-WEV	18.8	0.0	18.9	0.0	9	27.8	27.9	27.4	27.2	27.3	-10
511	HRV-HRH	24.7	0.0	24.8	0.0	9	33.7	33.8	35.1	33.8	33.9	-10
621	FHWOH_D1_BASE	8.0	1.5	8.0	1.5	0	8.0c.l	8.0c.l	9.0c.l.	9.0c.l.	9.0c.l.	5
660706	Internal Rad -Y under foot	3.6	0.0	3.6	0.0	0	3.6c.l	3.6c.l	0	10	-25	55
622	FHWEH_D1	21.4	25.7	21.4	25.7	7.8	29.2	29.2	0	30	-25	55
623	FHHRH_D1	29.4	66.3	29.5	66.3	8.8	38.2	38.3	-10	40	-25	55
624	FHLCU_D1	27.0	37.6	27.0	37.6	8	35.0	35.0	-10	40	-25	55
625	FHLSU_D1	28.4	35.8	28.4	35.8	8	36.4	36.4	10	40	-25	55
606	FHIFH_D1	16.2	0.0	16.2	0.0	8	24.2	24.2	-10	40	-25	55
607	IFH-HRH	25.8	0.0	25.8	0.0	9	34.8	34.8	-10	40	-25	55
608	IFH-WEH	26.0	0.0	26.0	0.0	9	35.0	35.0	-10	40	-25	55
609	WEH-WOH	25.5	0.0	25.5	0.0	9	34.5	34.5	-10	40	-25	55
701	RWL1	46.3	25.0	46.4	25.0	8	54.3	54.4	0	55	-10	65
702	RWL2	36.0	10.0	36.0	10.0	8	44.0	44.0	0	55	-10	65
703	RWL3	40.8	15.0	40.9	15.0	8	48.8	48.9	0	55	-10	65
704	RWL4	37.4	10.0	37.5	10.0	8	45.4	45.5	0	55	-10	65
8133	FCV BODY MAIN	47.4	0.0	46.9	0.0	8	55.4	54.9	10	60	10	60
8233	FCV BODY MAIN	40.5	0.0	39.8	0.0	8	48.5	47.8	10	60	10	60
8333	FCV BODY MAIN	40.6	0.0	39.7	0.0	8	48.6	47.7	10	60	10	60
8433	FCV BODY MAIN	35.8	0.0	36.0	0.0	8	43.8	44.0	10	60	10	60
8533	FCV BODY MAIN	39.9	0.0	40.0	0.0	8	47.9	48.0	10	60	10	60
8633	FCV BODY MAIN	42.7	0.0	42.8	0.0	8	50.7	50.8	10	60	10	60
8134	FCV BODY REDUNDANT	47.2	0.0	46.7	0.0	8	55.2	54.7	10	60	10	60
8234	FCV BODY REDUNDANT	40.5	0.0	39.8	0.0	8	48.5	47.8	10	60	10	60
8334	FCV BODY REDUNDANT	40.6	0.0	39.6	0.0	8	48.6	47.6	10	60	10	60
8434	FCV BODY REDUNDANT	35.9	0.0	36.1	0.0	8	43.9	44.1	10	60	10	60
8534	FCV BODY REDUNDANT	40.0	0.0	40.1	0.0	8	48.0	48.1	10	60	10	60
8634	FCV BODY REDUNDANT	42.5	0.0	42.6	0.0	8	50.5	50.6	10	60	10	60
80029	STR1+X FOOT	-3.5	0.0	25.5	0.0	(*)	0.3	32.6	-20	40	-30	50
81029	STR2+X FOOT	11.1	0.0	25.6	0.0	(*)	11.1c.l	32.7	-20	40	-30	50
1501	RCS #9 - LINE 1	41.4	0.0	41.5	0.0	8	49.4	49.5	10	50	10	50
1502	RCS #9 - LINE 1	41.4	0.0	41.5	0.0	8	49.4	49.5	10	50	10	50
1503	RCS #9 - LINE 1	41.4	0.0	41.5	0.0	8	49.4	49.5	10	50	10	50
1504	RCS #9 - LINE 1	41.4	0.0	41.5	0.0	8	49.4	49.5	10	50	10	50
1505	RCS #9 - LINE 1	41.4	0.0	41.5	0.0	8	49.4	49.5	10	50	10	50
1506	RCS #9 - LINE 1	37.1	0.0	37.2	0.0	8	45.1	45.2	10	50	10	50
1507	RCS #9 - LINE 1	41.3	0.0	41.4	0.0	8	49.3	49.4	10	50	10	50
1508	RCS #9 - LINE 1	41.3	0.0	41.4	0.0	8	49.3	49.4	10	50	10	50
1509	RCS #9 - LINE 1	37.1	0.0	37.2	0.0	8	45.1	45.2	10	50	10	50
1512	RCS #9 - LINE 1	39.4	0.0	39.0	0.0	8	47.4	47.0	10	50	10	50
1513	RCS #9 - LINE 1	42.8	0.0	43.0	0.0	8	50.8	51.0	10	50	10	50
1514	RCS #9 - LINE 1	42.3	0.0	41.6	0.0	8	50.3	49.6	10	50	10	50
1515	RCS #9 - LINE 1	42.2	0.0	41.2	0.0	8	50.2	49.2	10	50	10	50
1516	RCS #9 - LINE 1	43.0	0.0	41.7	0.0	8	51.0	49.7	10	50	10	50
1517	RCS #9 - LINE 1	43.1	0.0	42.1	0.0	8	51.1	50.1	10	50	10	50



Controlled Distribution



REFERENCE : H-P-RP-AI-0040

DATE : 29/SEP/06

ISSUE : 06

Page : 198/405

NODE	LABEL	TEMPERATURE RESULTS AND LIMITS										
		Brid	Brid	C 2STR ON	C 2STR ON	UFP [°C]	Brid	C 2STR ON	MIN OPER. [°C]	MAX OPER. [°C]	MIN N.OPER [°C]	MAX N.OPER [°C]
		TEMP [°C]	PW [W]	TEMP [°C]	PW [W]		TEMP-UFP [°C]	TEMP-UFP [°C]				
1518	RCS #9 - LINE 1	44.4	0.0	43.8	0.0	8	52.4	51.8	10	50	10	50
1519	RCS #9 - LINE 1	47.3	0.0	46.8	0.0	8	55.3	54.8	10	50	10	50
1520	RCS #9 - LINE 1	41.4	0.0	41.5	0.0	8	49.4	49.5	10	50	10	50
1522	RCS #9 - LINE 1	44.7	0.0	43.9	0.0	8	52.7	51.9	10	50	10	50
1523	RCS #9 - LINE 1	45.4	0.0	44.7	0.0	8	53.4	52.7	10	50	10	50
1524	RCS #11 - LINE 2	38.0	0.0	37.7	0.0	8	46.0	45.7	10	50	10	50
1525	RCS #11 - LINE 2	38.0	0.0	37.7	0.0	8	46.0	45.7	10	50	10	50
1526	RCS #11 - LINE 2	37.8	0.0	38.5	0.0	8	45.8	46.5	10	50	10	50
1527	RCS #11 - LINE 2	37.4	0.0	38.0	0.0	8	45.4	46.0	10	50	10	50
1528	RCS #11 - LINE 2	37.4	0.0	38.0	0.0	8	45.4	46.0	10	50	10	50
1529	RCS #11 - LINE 2	34.3	0.0	34.2	0.0	8	42.3	42.2	10	50	10	50
1530	RCS #11 - LINE 2	34.3	0.0	34.2	0.0	8	42.3	42.2	10	50	10	50
1531	RCS #11 - LINE 2	33.7	0.0	33.5	0.0	8	41.7	41.5	10	50	10	50
1532	RCS #11 - LINE 2	34.1	0.0	34.0	0.0	8	42.1	42.0	10	50	10	50
1533	RCS #11 - LINE 2	38.1	0.0	37.8	0.0	8	46.1	45.8	10	50	10	50
1534	RCS #11 - LINE 2	38.1	0.0	37.8	0.0	8	46.1	45.8	10	50	10	50
1535	RCS #11 - LINE 2	38.1	0.0	37.8	0.0	8	46.1	45.8	10	50	10	50
1536	RCS #11 - LINE 2	38.1	0.0	37.8	0.0	8	46.1	45.8	10	50	10	50
1537	RCS #11 - LINE 2	37.2	0.0	36.7	0.0	8	45.2	44.7	10	50	10	50
1538	RCS #11 - LINE 2	36.6	0.0	35.7	0.0	8	44.6	43.7	10	50	10	50
1539	RCS #11 - LINE 2	28.8	0.0	27.8	0.0	8	36.8	35.8	10	50	10	50
1540	RCS #11 - LINE 2	28.8	0.0	27.8	0.0	8	36.8	35.8	10	50	10	50
1541	RCS #11 - LINE 2	29.6	0.0	28.1	0.0	8	37.6	36.1	10	50	10	50
1542	RCS #11 - LINE 2	35.8	0.0	34.1	0.0	8	43.8	42.1	10	50	10	50
1543	RCS #11 - LINE 2	40.5	0.0	39.8	0.0	9	49.5	48.8	10	50	10	50
1544	RCS #11 - LINE 2	33.3	0.0	33.0	0.0	8	41.3	41.0	10	50	10	50
1545	RCS #11 - LINE 2	33.3	0.0	33.0	0.0	8	41.3	41.0	10	50	10	50
1546	RCS #11 - LINE 2	33.3	0.0	33.0	0.0	8	41.3	41.0	10	50	10	50
1547	RCS #11 - LINE 2	33.3	0.0	33.0	0.0	8	41.3	41.0	10	50	10	50
1548	RCS #11 - LINE 2	34.7	0.0	34.6	0.0	8	42.7	42.6	10	50	10	50
1549	RCS #11 - LINE 2	35.8	0.0	35.6	0.0	8	43.8	43.6	10	50	10	50
1550	RCS #11 - LINE 2	35.8	0.0	35.6	0.0	8	43.8	43.6	10	50	10	50
1551	RCS #35 - LINE 3a	32.5	0.0	32.8	0.0	8	40.5	40.8	10	50	10	50
1552	RCS #35 - LINE 3a	32.5	0.0	32.8	0.0	8	40.5	40.8	10	50	10	50
1553	RCS #35 - LINE 3a	32.5	0.0	32.8	0.0	8	40.5	40.8	10	50	10	50
1554	RCS #35 - LINE 3a	32.5	0.0	32.8	0.0	8	40.5	40.8	10	50	10	50
1555	RCS #35 - LINE 3a	32.5	0.0	32.8	0.0	8	40.5	40.8	10	50	10	50
1556	RCS #35 - LINE 3a	30.2	0.0	30.6	0.0	8	38.2	38.6	10	50	10	50
1557	RCS #35 - LINE 3a	30.2	0.0	30.6	0.0	8	38.2	38.6	10	50	10	50
1558	RCS #35 - LINE 3a	30.2	0.0	30.6	0.0	8	38.2	38.6	10	50	10	50
1559	RCS #35 - LINE 3a	30.2	0.0	30.6	0.0	8	38.2	38.6	10	50	10	50
1560	RCS #35 - LINE 3a	30.2	0.0	30.6	0.0	8	38.2	38.6	10	50	10	50
1561	RCS #35 - LINE 3a	30.1	0.0	29.9	0.0	8	38.1	37.9	10	50	10	50
1562	RCS #35 - LINE 3a	30.0	0.0	29.1	0.0	8	38.0	37.1	10	50	10	50
1563	RCS #35 - LINE 3a	29.3	0.0	27.3	0.0	8	37.3	35.3	10	50	10	50
1564	RCS #35 - LINE 3a	29.3	0.0	27.3	0.0	8	37.3	35.3	10	50	10	50
1565	RCS #35 - LINE 3a	29.6	0.0	28.0	0.0	8	37.6	36.0	10	50	10	50
1566	RCS #35 - LINE 3a	28.4	0.0	26.5	0.0	8	36.4	34.5	10	50	10	50
1567	RCS #35 - LINE 3a	40.6	0.0	39.7	0.0	8	48.6	47.7	10	50	10	50
1450	RCS#48-3b- LF	27.8	0.0	28.6	0.0	8	35.8	36.6	10	50	10	50
1477	RCS#48-3b- LV1	28.5	0.0	29.2	0.0	8	36.5	37.2	10	50	10	50



Controlled Distribution



REFERENCE : H-P-RP-AI-0040

DATE : 29/SEP/06

ISSUE : 06

Page : 199/405

NODE	LABEL	TEMPERATURE RESULTS AND LIMITS										
		Brid	Brid	C 2STR ON	C 2STR ON	UFP [°C]	Brid	C 2STR ON	MIN OPER. [°C]	MAX OPER. [°C]	MIN N.OPER [°C]	MAX N.OPER [°C]
		TEMP [°C]	PW [W]	TEMP [°C]	PW [W]		TEMP-UFP [°C]	TEMP-UFP [°C]				
1482	RCS#48-3b- LV2	28.3	0.0	29.1	0.0	8	36.3	37.1	10	50	10	50
1487	RCS#48-3b- PT	23.2	0.0	24.0	0.0	8	31.2	32.0	10	50	10	50
1568	RCS #37 - LINE 3c	29.8	0.0	30.2	0.0	8	37.8	38.2	10	50	10	50
1569	RCS #37 - LINE 3c	30.2	0.0	30.6	0.0	8	38.2	38.6	10	50	10	50
1570	RCS #37 - LINE 3c	32.4	0.0	32.7	0.0	8	40.4	40.7	10	50	10	50
1571	RCS #37 - LINE 3c	32.4	0.0	32.7	0.0	8	40.4	40.7	10	50	10	50
1572	RCS #37 - LINE 3c	30.2	0.0	30.6	0.0	8	38.2	38.6	10	50	10	50
1573	RCS #37 - LINE 3c	29.1	0.0	29.8	0.0	8	37.1	37.8	10	50	10	50
1574	RCS #37 - LINE 3c	28.8	0.0	29.5	0.0	8	36.8	37.5	10	50	10	50
1576	RCS #37 - LINE 3c	27.5	0.0	28.3	0.0	8	35.5	36.3	10	50	10	50
1578	RCS #37 - LINE 3c	29.1	0.0	29.7	0.0	8	37.1	37.7	10	50	10	50
1580	RCS #37 - LINE 3c	29.8	0.0	30.3	0.0	8	37.8	38.3	10	50	10	50
1581	RCS #37 - LINE 3c	28.9	0.0	29.6	0.0	8	36.9	37.6	10	50	10	50
1583	RCS #37 - LINE 3c	27.8	0.0	28.6	0.0	8	35.8	36.6	10	50	10	50
1584	RCS #37 - LINE 3c	28.3	0.0	29.1	0.0	8	36.3	37.1	10	50	10	50
1585	RCS #37 - LINE 3c	27.8	0.0	28.6	0.0	8	35.8	36.6	10	50	10	50
1586	RCS #37 - LINE 3c	27.4	0.0	28.2	0.0	8	35.4	36.2	10	50	10	50
1588	RCS #37 - LINE 3c	31.3	0.0	31.5	0.0	8	39.3	39.5	10	50	10	50
1589	RCS #37 - LINE 3c	33.3	0.0	33.5	0.0	8	41.3	41.5	10	50	10	50
1590	RCS #37 - LINE 3c	29.3	0.0	29.6	0.0	8	37.3	37.6	10	50	10	50
1591	RCS #37 - LINE 3c	31.4	0.0	31.6	0.0	8	39.4	39.6	10	50	10	50
1592	RCS #37 - LINE 3c	31.4	0.0	31.6	0.0	8	39.4	39.6	10	50	10	50
1593	RCS #37 - LINE 3c	31.8	0.0	32.0	0.0	8	39.8	40.0	10	50	10	50
1594	RCS #37 - LINE 3c	35.9	0.0	36.1	0.0	8	43.9	44.1	10	50	10	50
1595	RCS #45 - LINE 4	31.3	0.0	31.5	0.0	8	39.3	39.5	10	50	10	50
1596	RCS #45 - LINE 4	31.3	0.0	31.5	0.0	8	39.3	39.5	10	50	10	50
1597	RCS #45 - LINE 4	31.3	0.0	31.5	0.0	8	39.3	39.5	10	50	10	50
1598	RCS #45 - LINE 4	31.3	0.0	31.5	0.0	8	39.3	39.5	10	50	10	50
1599	RCS #45 - LINE 4	31.3	0.0	31.5	0.0	8	39.3	39.5	10	50	10	50
1400	RCS #45 - LINE 4	33.3	0.0	33.5	0.0	8	41.3	41.5	10	50	10	50
1401	RCS #45 - LINE 4	33.3	0.0	33.5	0.0	8	41.3	41.5	10	50	10	50
1402	RCS #45 - LINE 4	33.3	0.0	33.5	0.0	8	41.3	41.5	10	50	10	50
1403	RCS #45 - LINE 4	33.3	0.0	33.5	0.0	8	41.3	41.5	10	50	10	50
1404	RCS #45 - LINE 4	33.3	0.0	33.5	0.0	8	41.3	41.5	10	50	10	50
1405	RCS #45 - LINE 4	31.4	0.0	31.6	0.0	8	39.4	39.6	10	50	10	50
1406	RCS #45 - LINE 4	31.6	0.0	31.8	0.0	8	39.6	39.8	10	50	10	50
1407	RCS #45 - LINE 4	28.4	0.0	28.5	0.0	8	36.4	36.5	10	50	10	50
1408	RCS #45 - LINE 4	28.4	0.0	28.5	0.0	8	36.4	36.5	10	50	10	50
1409	RCS #45 - LINE 4	27.5	0.0	27.7	0.0	8	35.5	35.7	10	50	10	50
1410	RCS #45 - LINE 4	27.5	0.0	27.6	0.0	8	35.5	35.6	10	50	10	50
1411	RCS #45 - LINE 4	39.9	0.0	40.0	0.0	8	47.9	48.0	10	50	10	50
1412	RCS #46 - LINE 5a	34.6	0.0	34.8	0.0	8	42.6	42.8	10	50	10	50
1413	RCS #46 - LINE 5a	34.6	0.0	34.8	0.0	8	42.6	42.8	10	50	10	50
1414	RCS #46 - LINE 5a	34.6	0.0	34.8	0.0	8	42.6	42.8	10	50	10	50
1415	RCS #46 - LINE 5a	34.6	0.0	34.8	0.0	8	42.6	42.8	10	50	10	50
1416	RCS #46 - LINE 5a	37.1	0.0	37.2	0.0	8	45.1	45.2	10	50	10	50
1417	RCS #46 - LINE 5a	37.1	0.0	37.2	0.0	8	45.1	45.2	10	50	10	50
1418	RCS #46 - LINE 5a	37.1	0.0	37.2	0.0	8	45.1	45.2	10	50	10	50
1419	RCS #46 - LINE 5a	35.9	0.0	36.0	0.0	8	43.9	44.0	10	50	10	50
1421	RCS #46 - LINE 5a	34.7	0.0	34.9	0.0	8	42.7	42.9	10	50	10	50
1422	RCS #46 - LINE 5a	34.8	0.0	35.0	0.0	8	42.8	43.0	10	50	10	50



Controlled Distribution



REFERENCE : H-P-RP-AI-0040

DATE : 29/SEP/06

ISSUE : 06

Page : 200/405

NODE	LABEL	TEMPERATURE RESULTS AND LIMITS										
		Brid	Brid	C 2STR ON	C 2STR ON	UFP [°C]	Brid	C 2STR ON	MIN OPER. [°C]	MAX OPER. [°C]	MIN N.OPER [°C]	MAX N.OPER [°C]
		TEMP [°C]	PW [W]	TEMP [°C]	PW [W]		TEMP-UFP [°C]	TEMP-UFP [°C]				
1423	RCS #46 - LINE 5a	34.8	0.0	35.0	0.0	8	42.8	43.0	10	50	10	50
1424	RCS #46 - LINE 5a	34.8	0.0	35.0	0.0	8	42.8	43.0	10	50	10	50
1425	RCS #46 - LINE 5a	34.8	0.0	35.0	0.0	8	42.8	43.0	10	50	10	50
1426	RCS #47 - LINE 5b	36.7	0.0	36.8	0.0	8	44.7	44.8	10	50	10	50
1427	RCS #47 - LINE 5b	36.8	0.0	36.9	0.0	8	44.8	44.9	10	50	10	50
1428	RCS #47 - LINE 5b	37.1	0.0	37.2	0.0	8	45.1	45.2	10	50	10	50
1429	RCS #47 - LINE 5b	37.1	0.0	37.2	0.0	8	45.1	45.2	10	50	10	50
1430	RCS #47 - LINE 5b	40.8	0.0	40.9	0.0	8	48.8	48.9	10	50	10	50
1431	RCS #47 - LINE 5b	40.8	0.0	40.9	0.0	8	48.8	48.9	10	50	10	50
1432	RCS #47 - LINE 5b	37.2	0.0	37.2	0.0	8	45.2	45.2	10	50	10	50
1433	RCS #47 - LINE 5b	37.1	0.0	37.2	0.0	8	45.1	45.2	10	50	10	50
1434	RCS #47 - LINE 5b	37.1	0.0	37.2	0.0	8	45.1	45.2	10	50	10	50
1435	RCS #47 - LINE 5b	37.1	0.0	37.2	0.0	8	45.1	45.2	10	50	10	50
1437	RCS #47 - LINE 5b	35.8	0.0	35.9	0.0	8	43.8	43.9	10	50	10	50
1438	RCS #47 - LINE 5b	33.8	0.0	33.9	0.0	8	41.8	41.9	10	50	10	50
1439	RCS #47 - LINE 5b	33.8	0.0	33.9	0.0	8	41.8	41.9	10	50	10	50
1440	RCS #47 - LINE 5b	33.0	0.0	33.1	0.0	8	41.0	41.1	10	50	10	50
1441	RCS #47 - LINE 5b	36.1	0.0	36.2	0.0	8	44.1	44.2	10	50	10	50
1442	RCS #47 - LINE 5b	42.6	0.0	42.7	0.0	8	50.6	50.7	10	50	10	50

(*) the STR uncertainty is: with control law 0°C for STR “on” and 3.8°C for STR “off”; without control law 7.1°C for STR “on”

Table 8.4.4-1 HERSCHEL – Redundancy analysis temperature results



Controlled Distribution

8.4.5 STR Analysis: STR1 and STR2 operative together for the entire S/C life

Some sensitivity analyses have been performed in order to evaluate the possibility to keep both STRs switched ON for the entire mission life of Herschel satellite (all Sun Acquisition Attitudes verified) remaining within the stability requirements.

The following analyses have been performed:

- 1) Both STRs switched ON during the Star Trackers hottest case (case C EOL SAA-30°).
In this case the STR panel temperature is 19°C (without uncertainties).

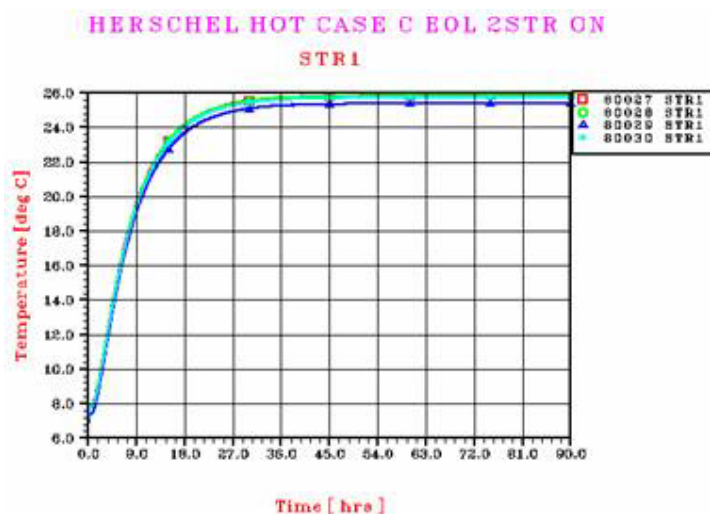

Controlled Distribution

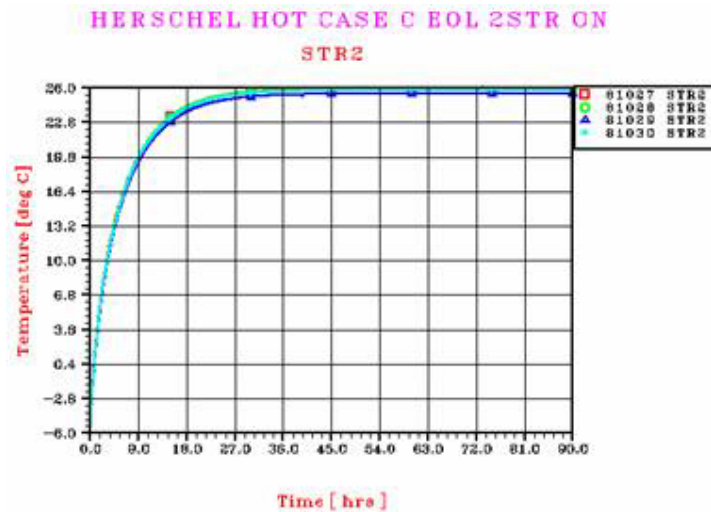

2) To control actively the 2 STR ON is needed to have a set point, fixed for the entire operative mission, at a temperature equal to 28°C (19°C plus uncertainties) at STR panel level.
The following temperature results have been obtained keeping this set point.

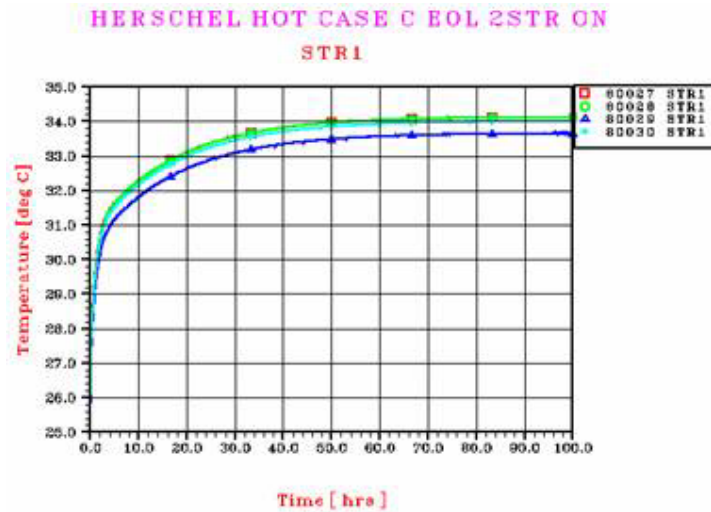

Controlled Distribution



REFERENCE : H-P-RP-AI-0040

DATE : 29/SEP/06

ISSUE : 06

Page : 203/405

HERSCHEL HOT CASE C EOL 2STR ON
STR PANEL

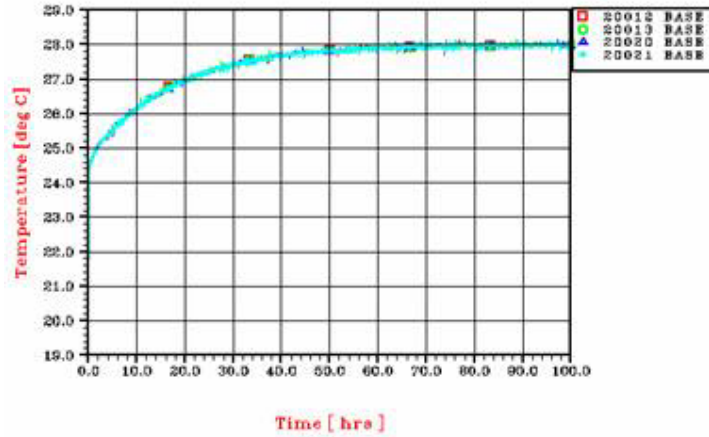

HERSCHEL HOT CASE C EOL 2STR ON
STR2

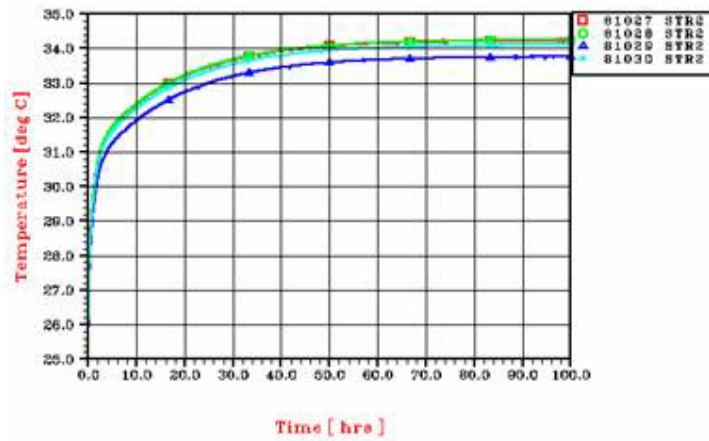

Controlled Distribution

- 3) An evaluation during a nominal coldest case (case G BOL SAA+30) has been made keeping the same set point (28°C on STR panel).

The conclusion is that the installed heater power allows to keep this set point at the required value and then to verify the stability requirement. In this cold case the heater power consumption is equal to 13 watt (installed Power is 21 watt).



Controlled Distribution



REFERENCE : H-P-RP-AI-0040

DATE : 29/SEP/06

ISSUE : 06

Page : 205/405



8.5 PLANCK Thermal analysis

TRANSIENT NOMINAL ANALYSIS

The nominal analysis have been performed considering transient cases with the S/C operating 21 hours in Scientific mode and 3 hrs in Telecom mode. The analysis takes into account also the cyclic variation of SCC power dissipation on each bed (see paragraph 5.2.2.1)

The list of the orbital Transient cases analysed is presented in the following table:

CASE	BOL / EOL	SUN ON PANEL	SAA [deg]	ATTITUDE	SOLAR CONSTANT [W/m ²]	Remarks
A1	BOL	+Z	10	Rot X = 0 Rot Y = +10	Summer: 1285	Nominal BOL – Dissipation MODE1
A2	BOL	+Z	10	Rot X = 0 Rot Y = +10	Summer: 1285	Nominal BOL – Dissipation MODE2
A3	BOL	+Z	10	Rot X = 0 Rot Y = +10	Summer: 1285	Nominal BOL – Dissipation MODE3
B1	EOL	+Z	0	Rot X = 0 Rot Y = 0	Winter: 1405	Nominal EOL – SCC1 on
B2	EOL	+Z	0	Rot X = 0 Rot Y = 0	Winter: 1405	Nominal EOL – SCC2 on
C	BOL	+Z	10	Rot X = 0 Rot Y = +10	Summer: 1285	Survival BOL

Table 8.5-1- PLANCK Transient nominal analysis cases

The spin of the satellite around its X-axis (1.7 round per minute) has a negligible effect on the amount of solar fluxes on the sun-exposed surfaces, so it is not considered in the current analysis.

CHANGE OF ATTITUDE TRANSIENT ANALYSIS

To verify the thermal stability requirement for the SCC Radiative Panels and the SVM/PLM I/F points transient analysis have been performed taking into account the variation of SCC Power dissipation on each bed; moreover a change of attitude of the satellite from SAA=0° to SAA=10° has been considered at time = 86400 sec.

The analysed cases are the following:

- **Cold Transient (Case P1):**
Starting from S/S BOL case with Sun on -X and SAA= 0°. Solar constant=1285 W/m²
Ending to S/S BOL case with Sun on -X and SAA=+10°. Solar constant=1285 W/m²
Duration of change of attitude: 1200s
Rotation rate: 0.5°/min
Overall duration of transient case: 348600s (72 hours)
Dissipation as per nominal case A1 (with SCC1 on and SCC2 off)

Controlled Distribution



REFERENCE : H-P-RP-AI-0040

DATE : 29/SEP/06

ISSUE : 06

Page : 207/405

- **Cold Transient (Case P2):**
Starting from S/S BOL case with Sun on $-X$ and $SAA=0^\circ$. Solar constant= 1285 W/m^2
Ending to S/S BOL case with Sun on $-X$ and $SAA=+10^\circ$. Solar constant= 1285 W/m^2
Duration of change of attitude: 1200s
Rotation rate: $0.5^\circ/\text{min}$
Overall duration of transient case: 348600s (72 hours)
Dissipation as per nominal case A1 (with SCC1 off and SCC2 on)
- **Hot Transient (Case Q1):**
Starting from S/S EOL case with Sun on $-X$ and $SAA=0^\circ$. Solar constant= 1405 W/m^2
Ending to S/S EOL case with Sun on $-X$ and $SAA=+10^\circ$. Solar constant= 1405 W/m^2
Duration of change of attitude: 1200s
Rotation rate: $0.5^\circ/\text{min}$
Overall duration of transient case: 348600s (72 hours)
Dissipation as per nominal case B1
- **Hot Transient (Case Q2):**
Starting from S/S EOL case with Sun on $-X$ and $SAA=0^\circ$. Solar constant= 1405 W/m^2
Ending to S/S EOL case with Sun on $-X$ and $SAA=+10^\circ$. Solar constant= 1405 W/m^2
Duration of change of attitude: 1200s
Rotation rate: $0.5^\circ/\text{min}$
Overall duration of transient case: 348600s (72 hours)
Dissipation as per nominal case B2

REDUNDANCY TRANSIENT ANALYSIS

A series of additional analysis have been performed to verify the temperatures behaviour when the redundancy units are activated. The analysis results are reported in paragraph 8.5.4.3



Controlled Distribution



REFERENCE : H-P-RP-AI-0040

DATE : 29/SEP/06

ISSUE : 06

Page : 208/405

8.5.1 SCC dissipation profile

The working SCC have two different dissipation profiles hereafter reported according to [AD38]:

Phase	VG3 temp	SCC dissipation	SCE dissipation	Time cycle
BOL cold case	45 K	297 W	60 W	940 s
EOL hot case	60 K	460 W	110 W	667 s

Each SCC is composed of six thermal nodes for the Inner bed and six for the Outer shell, for each thermal node is considered the thermal capacity, the linear conductor and the power dissipation for each phase and has been utilised a simplified BOL and EOL thermal mathematical model reported in Table 8.5.1-1/2

In Table 8.5.1-3 are reported the value relative to Gas-gap conductance for a period time of 667 and 940 seconds. .



Controlled Distribution

REFERENCE : H-P-RP-AI-0040

DATE : 29/SEP/06

ISSUE : 06

Page : 209/405

BOL 260-45-297 SCC COLD CASE TMM: radiator @ 260 K, VG3 @ 45 K, dissipation:297 W, time cycle: 940 sec

Parameter	Location	Units	Phase 1	Phase 2	Phase 3	Phase 4	Phase 5	Phase 6
			Heatup 0-940 s	Desorb 941-1880 s	Cool 1881-2820 s	Absorb 2821-3760 s	Absorb 3761-4700 s	Absorb 4701-5640 s
Therm. Mass	Inner Bed	MC _p (J/K)	800	3600	900	670	690	710
	Outer Shell	MC _p (J/K)	720	720	720	720	720	720
Conductance	(Inner Bed to Outer Shell)	W/K	0,02	0,03	**	6,53	6,53	6,53
Heat Input	Inner Bed	W	134	130	0	50	27	22
	Outer shell	W	0	0	8	8	8	8

**** see Table 8.5.1-3**

Table 8.5.1-1 PLANCK - Simplified BOL SCC model

Controlled Distribution

REFERENCE : H-P-RP-AI-0040

DATE : 29/SEP/06

ISSUE : 06

Page : 210/405

BOL 280-60-460 SCC HOT CASE TMM: Radiator @ 280 K, VG3 @ 60 K, dissipation: 460 W, time cycle: 667 sec								
Parameter	Location	Units	Phase 1 Heatup 0-667 s	Phase 2 Desorb 668-1334 s	Phase 3 Cool 1335-2001 s	Phase 4 Absorb 2002-2668 s	Phase 5 Absorb 2669-3335 s	Phase 6 Absorb 3336-4002 s
Therm. Mass	Inner Bed	MC _p (J/K)	800	3600	900	670	690	710
	Outer Shell	MC _p (J/K)	720	720	720	720	720	720
Conductance	<i>(Inner Bed to Outer Shell)</i>	W/K	0,02	0,03	***	6,53	6,53	6,53
Heat Input	Inner Bed	W	240	185	0	50	36	22
	Outer shell	W	0	0	9	9	9	9

**** see Table 8.5.1-3**

Table 8.5.1-2 PLANCK - Simplified EOL SCC model

Controlled Distribution



REFERENCE : H-P-RP-AI-0040

DATE : 29/SEP/06

ISSUE : 06

Page : 211/405

Time	Gas gap Conductance	Time	Gas gap Conductance	Time	Gas gap Conductance	Time	Gas gap Conductance
[s]	[W/K]	[s]	[W/K]	[s]	[W/K]	[s]	[W/K]
0	0,0313	47	0,9855	94	6,0902	141	6,5264
1	0,0314	48	1,1518	95	6,1119	142	6,5291
2	0,0316	49	1,3457	96	6,1314	143	6,5315
3	0,0318	50	1,5667	97	6,1514	144	6,5335
4	0,0319	51	1,8118	98	6,1705	145	6,5356
5	0,0321	52	2,0749	99	6,1886	146	6,5373
6	0,0325	53	2,3479	100	6,2058	147	6,5393
7	0,0329	54	2,6215	101	6,2216	148	6,5409
8	0,0331	55	2,8875	102	6,2375	149	6,5423
9	0,0337	56	3,1393	103	6,2526	150	6,5436
10	0,0344	57	3,3734	104	6,2673	151	6,5450
11	0,0352	58	3,5880	105	6,2808	152	6,5463
12	0,0359	59	3,7832	106	6,2940	153	6,5473
13	0,0368	60	3,9600	107	6,3069	154	6,5480
14	0,0383	61	4,2804	108	6,3187	155	6,5488
15	0,0397	62	4,4133	109	6,3307	156	6,5497
16	0,0414	63	4,5360	110	6,3420	157	6,5505
17	0,0434	64	4,6454	111	6,3526	158	6,5512
18	0,0459	65	4,7481	112	6,3634	159	6,5519
19	0,0487	66	4,8422	113	6,3728	160	6,5525
20	0,0519	67	4,9295	114	6,3824	161	6,5530
21	0,0558	68	5,0096	115	6,3914	162	6,5534
22	0,0602	69	5,0853	116	6,4003	163	6,5536
23	0,0653	70	5,1568	117	6,4086	164	6,5537
24	0,0709	71	5,2245	118	6,4171	165	6,5539
25	0,0775	72	5,2856	119	6,4247	166	6,5541
26	0,0849	73	5,3454	120	6,4321	167	6,5542
27	0,0934	74	5,4002	121	6,4391	940 or 667	6,5543
28	0,1029	75	5,4532	122	6,4456	Depending on cycle time	
29	0,1137	76	5,5034	123	6,4516		
30	0,1258	77	5,5503	124	6,4578		
31	0,1393	78	5,5956	125	6,4636		
32	0,1546	79	5,6379	126	6,4689		
33	0,1716	80	5,6789	127	6,4738		
34	0,1908	81	5,7178	128	6,4793		
35	0,2123	82	5,7541	129	6,4837		
36	0,2366	83	5,7893	130	6,4887		
37	0,2641	84	5,8235	131	6,4932		
38	0,2956	85	5,8553	132	6,4971		
39	0,3317	86	5,8862	133	6,5009		
40	0,3735	87	5,9163	134	6,5049		
41	0,4224	88	5,9436	135	6,5083		
42	0,4799	89	5,9708	136	6,5119		
43	0,5482	90	5,9967	137	6,5151		
44	0,6297	91	6,0219	138	6,5183		
45	0,7276	92	6,0453	139	6,5214		
46	0,8556	93	6,0680	140	6,5242		

Table 8.5.1-3 PLANCK - Gas gap conductance

Controlled Distribution



REFERENCE : H-P-RP-AI-0040

DATE : 29/SEP/06

ISSUE : 06

Page : 212/405

8.5.2 Planck Heater Sizing and Breakdown

The Heater circuit breakdown with the heater power impressed on the TMM nodes is shown in Table 5.2.3-1

Table 8.5.2-1 PLANCK – Heater Circuits Breakdown and Temperature Thresholds

Heater line	HEATER's location	Heaters on Node	Power on node [W]	Power line @27 V [W]	Threshold Nom. [°C]	Threshold Surv. [°C]
TCS Line 01	close to STR 1	5481	1.566	4.70	-19/-16	-19/-16
		5482	1.566			
		5483	1.566			
TCS Line 02	close to STR 2	5581	1.566	4.70	-19/-16	-19/-16
		5582	1.566			
		5583	1.566			
TCS Line 03	close to DPU1	6029	11.39	22.78	-9/-6	-9/-6
		6039	11.39			
TCS Line 04	close to DPU2	6036	11.39	22.78	-9/-6	-9/-6
		6034	11.39			
TCS Line 05	Close to REU	6268	15.51	62.00	-9/-6	-9/-6
		6261	15.51			
		6260	7.75			
		6264	7.75			
		6265	7.75			
		6269	7.75			
TCS Line 06	Close to CEU/CCU	6240	15.51	52.50	-9/-6	-9/-6
		62012	5.7			
		62020	5.7			
		62013	2.35			
		62021	2.35			
		62018	8.1			
		62024	8.1			
		62043	4.7			
TCS Line 07	on Heat Pipes	802	26.00	78.00	-10/-9	-10/-9
		805	26.00			
		808	26.00			
TCS Line 08	on Heat Pipes	851	26.00	78.00	-11/-10	-11/-10
		854	26.00			
		857	26.00			
TCS Line 09	on Heat Pipes	801	6.5	91	-12/-11	-12/-11
		803	6.5			
		804	26.00			
		806	26.00			
		807	26.00			
TCS Line 10	on Heat Pipes	852	6.5	91	-13/-12	-13/-12
		853	6.5			
		855	26.00			
		856	26.00			
TCS Line 11	on Heat Pipes	858	26.00	91	-14/-13	-14/-13
		802	6.5			
		852	6.5			
		855	26.00			
TCS Line 12	on Heat Pipes	806	26.00	91	-15/-14	-15/-14
		808	26.00			
		851	6.5			
		803	6.5			
		807	26.00			

Controlled Distribution



REFERENCE : H-P-RP-AI-0040

DATE : 29/SEP/06

ISSUE : 06

Page : 213/405

Heater line	HEATER's location	Heaters on Node	Power on node [W]	Power line @27 V [W]	Threshold Nom. [°C]	Threshold Surv. [°C]
TCS Line 13	on Heat Pipes	801	6.5	91	-16/-15	-16/-15
		853	6.5			
		804	26.00			
		854	26.00			
		856	26.00			
TCS Line 14	on Helium TANKS	910	2.08		-9/-6	-9/-6
		900	1.04			
		905	1.04			
TCS Line 15	close to PAU	598	8.1	8.1	-9/-6	-9/-6
TCS Line 16	close to CRU	5152	8.1 + 4.7	12.8	-9/-6	-9/-6
TCS Line 17	CRS 1	705	24.3	24.3	48/48.5	48/48.5
TCS Line 18	CRS 2	706	24.3	24.3	48/48.5	48/48.5
TCS Line 19	CRS 3	707	24.3	24.3	35/35.5	35/35.5
TCS Line 20	on TANK +Z+Y	920	0.77	2.31	N/A	N/A
	on TANK +Z-Y	925	0.77			
	on TANK -Z	930	0.77			
TCS Line 21	on TANK +Z+Y	920	5.4	5.4	11/14	11/14
TCS Line 22	on TANK +Z-Y	925	5.4	5.4	11/14	11/14
TCS Line 23	on TANK -Z	930	5.4	5.4	11/14	11/14
TCS Line 24	on FCV A1	8508	2.35	2.35	14/21	14/21
TCS Line 25	on FCV A2	8608	2.35	2.35	14/21	14/21
TCS Line 26	on FCV D1A	1133	1.43	1.43	14/21	14/21
TCS Line 27	on FCV D2A	1233	1.43	1.43	14/21	14/21
TCS Line 28	on FCV F1A	1333	1.43	1.43	14/21	14/21
TCS Line 29	on FCV F2A	1433	1.43	1.43	14/21	14/21
TCS Line 30	on FCV U1A	1533	1.43	1.43	14/21	14/21
TCS Line 31	on FCV U2A	1733	1.43	1.43	14/21	14/21
TCS Line 32	RCS Pipeline	--	--	4.9	23/24	23/24
TCS Line 33	RCS Pipeline	--	--	3.85	23/24	23/24
TCS Line 34	RCS Pipeline	--	--	4.88	27/28	27/28
TCS Line 35	close to CAU	62049	8.10	38.98	-9/-6	-9/-6
		62041	5.7			
		62045	5.7			
		62047	5.7			
		62054	8.10			
TCS Line 36	close to REBA1, REBA2	6134	5.7	22.78	-19/-16	-19/-16
		6133	5.7			
		6169	5.7			
		6170	5.7			
TCS Line 37	inside BATTERY	703	14.90	14.90	1/4	¼
TCS Line 38	on FCV B1	8708	2.35	2.35	14/21	14/21
TCS Line 39	on FCV B2	8808	2.35	2.35	14/21	14/21
TCS Line 40	on FCV D1B	1134	1.43	1.43	14/21	14/21
TCS Line 41	on FCV D2B	1234	1.43	1.43	14/21	14/21
TCS Line 42	on FCV F1B	1334	1.43	1.43	14/21	14/21
TCS Line 43	on FCV F2B	1434	1.43	1.43	14/21	14/21
TCS Line 44	on FCV U1B	1534	1.43	1.43	14/21	14/21
TCS Line 45	on FCV U2B	1734	1.43	1.43	14/21	14/21
TCS Line 46	RCS Pipeline	--	--	5.82	19/20	19/20
TCS Line 47	RCS Pipeline	--	--	9.23	19/20	19/20
TCS Line 48	RCS Pipeline	--	--	7.30	19/20	19/20

Controlled Distribution

8.5.3 Thermal stability

The PLANCK thermal stability requirements (ITP-220-P and ITP-230-P) relevant to Spectral Density (SD) and Fourier transform amplitude has been calculated as described below.

The software used is MathCad and the Fourier transform is computed as follow:

$$S_j = \frac{1}{\sqrt{N+1}} \sum_{k=0}^N S_k e^{\frac{2\pi jk}{(N+1)}}$$

(Note: the normalisation

$$\frac{1}{\sqrt{N+1}}$$

is that utilised by MathCad for the computation of the discrete Fourier transform.)

The Power Spectral Density (PSD_{sj}) is computed as follow:

$$PSD_{sj} = 2 \frac{|S_j|^2}{N+1} t_{\max} = 2N\Delta t \frac{|S_j|^2}{N+1}$$

The measurement unit of the PSD is [K^2/Hz], and consequently the SD_{sj} , to be used for the verification of the ITP-230-P, is:

$$SD_{sj} = \sqrt{PSD_{s,j}} = \sqrt{2N\Delta t} \frac{|S_j|}{\sqrt{N+1}}$$

with a measurement unit [$K/Hz^{1/2}$].

The temperature time history used to compute the SD is 7200 s long with a sampling time of 20 s as specified in the ITP-230-P. The start time of the time history occurs at the beginning of the S/C attitude change.

Concerning the amplitude of the Fourier Transform to be used for the verification of the ITP-220-P, the following applies.

Giving the Fourier transform (S_j) computed as above the amplitude is:

$$\text{amplitude}_{S_j} := \frac{|S_j|}{\sqrt{N+1}} \cdot 2$$

The measurement unit of the Fourier Transform Amplitude is [K].

The temperature time history used to compute the Fourier Transform Amplitude is 16008 s long (4 SCC complete cycle (4002s each one)) with a sampling time of 1 s. The start time of the time history occurs at the beginning of the S/C attitude change.

Controlled Distribution

REFERENCE : H-P-RP-AI-0040

DATE : 29/SEP/06

ISSUE : 06

Page : 215/405

8.5.4 Planck thermal analysis results

8.5.4.1 Transient nominal results

The temperature results of transient nominal analysis are reported in the table 5.2.5.1-1. The Table contains for the main S/L items, the relevant TMM node, its description, the uncertainty applied, the temperature results in the transient nominal analysis with the minimum values reported for the Cold cases and the maximum values reported for the Hot cases, the temperature with the relative uncertainty applied, the heater enabled according to the case analysed, identified by the “h” reported near the temperature value, the operative and non operative limits. All the temperatures are in degree Celsius.

The temperature uncertainty used is the one evaluated and reported in AD21 except for the following:

- In Cold cases (A1,A2,A3 and C) uncertainty are not applied to the units controlled by heaters
- In Hot cases (B1 and B2) uncertainty on SCC nodes is not applied due to the operating heater control also in these cases.

For RCS nodes, the uncertainty is always applied (both in hot and cold cases), and a value of 8°C has been assumed.

Table 8.5.4.1 PLANCK – Units Temperature Results

NODE	LABEL	UFP	CASE A1	CASE A2	CASE A3	CASE C	CASE B1	CASE B2	CASE A1	CASE A2	CASE A3	CASE C	CASE B1	CASE B2	TEMPERATURE LIMIT			
															MIN	MAX	MIN	MAX
			Min	Min	Min	Min	Max	Max	Tmin - UFP	Tmin - UFP	Tmin - UFP	Tmin - UFP	Tmax +UFP	Tmax +UFP	OPER.	OPER.	N. OP.	N. OP.
5427	STR_MY -X FOOT	9,2	6.5	4.5	4.5	-18.7	12.3	12.3	-2.7	-4.7	-4.7	-27.9	21.5	21.5	-20,0	40,0	-30,0	50,0
5428	STR_MY +Y FOOT	9,2	6.5	4.5	4.5	-18.8	12.2	12.2	-2.7	-4.7	-4.7	-28.0	21.4	21.4	-20,0	40,0	-30,0	50,0
5429	STR_MY +X FOOT	9,2	6.0	4.1	4.1	-18.8	11.8	11.8	-3.2	-5.1	-5.2	-28.0	21.0	21.0	-20,0	40,0	-30,0	50,0
5430	STR_MY -Y FOOT	9,2	6.3	4.3	4.3	-18.8	12.1	12.1	-2.9	-4.9	-4.9	-28.0	21.3	21.3	-20,0	40,0	-30,0	50,0
5527	STR_PY -X FOOT	7,3	-3.4	-5.4	-4.8	-15.5	2.4	2.4	-10.7	-12.7	-12.1	-22.8	9.7	9.7	-20,0	40,0	-30,0	50,0
5528	STR_PY +Y FOOT	7,3	-3.5	-5.5	-4.9	-15.6	2.3	2.3	-10.8	-12.8	-12.2	-22.9	9.6	9.6	-20,0	40,0	-30,0	50,0
5529	STR_PY +X FOOT	7,3	-3.4	-5.5	-4.9	-15.6	2.3	2.3	-10.7	-12.8	-12.2	-22.9	9.6	9.6	-20,0	40,0	-30,0	50,0

Controlled Distribution

REFERENCE : H-P-RP-AI-0040

DATE : 29/SEP/06

ISSUE : 06

Page : 216/405



NODE	LABEL	UFP													TEMPERATURE LIMIT			
			CASE A1	CASE A2	CASE A3	CASE C	CASE B1	CASE B2	CASE A1	CASE A2	CASE A3	CASE C	CASE B1	CASE B2	MIN	MAX	MIN	MAX
			Min	Min	Min	Min	Max	Max	Tmin - UFP	Tmin - UFP	Tmin - UFP	Tmin - UFP	Tmax +UFP	Tmax +UFP	OPER.	OPER.	N. OP.	N. OP.
5530	STR_PY -Y FOOT	7,2	-3.5	-5.5	-4.9	-15.6	2.3	2.3	-10.7	-12.7	-12.1	-22.8	9.5	9.5	-20,0	40,0	-30,0	50,0
13	DPU1	8,1	10.4	8.2	9.1	-9.0	16.2	16.2	2.3	0.1	1.0	-9.0 h	24.3	24.3	-10,0	40,0	-20,0	50,0
14	DPU2	7,6	-5.2	-7.4	-7.3	-9.1	0.9	0.9	-12.8	-15.0	-14.9	-9.1 h	8.5	8.5	-10,0	40,0	-20,0	50,0
101	DCCU	8	7.4	5.1	5.8	-12.7	13.7	13.7	-0.6	-2.9	-2.2	-12.7 h	21.7	21.7	-10,0	40,0	-20,0	50,0
102	REBA2	8,5	-4.1	-6.4	-6.8	-13.2	2.3	2.3	-12.6	-14.9	-15.3	-13.2 h	10.8	10.8	-20,0	50,0	-30,0	50,0
103	REBA1	7,8	6.3	4.1	4.4	-19.6	11.9	11.9	-1.5	-3.7	-3.4	-19.6 h	19.7	19.7	-20,0	50,0	-30,0	50,0
104	FOG (GEU)	8,3	23.2	20.9	19.3	-6.7	29.1	29.1	14.9	12.6	11.0	-15.0	37.4	37.4	0,0	45,0	-40,0	75,0
105	FOG (ICU)	8	10.2	7.6	7.8	-7.5	16.8	16.8	2.2	-0.4	-2.9	-15.5	24.8	24.8	0,0	45,0	-40,0	75,0
202	4K CAU	8,1	-3.5	-4.7	-4.0	-12.6	0.8	0.8	-3.5 h	-4.7 h	-4.0 h	-12.6 h	8.9	8.9	-10,0	40,0	-20,0	50,0
203	4KCRU (exPRE-REG)	8,7	24.9	22.8	13.1	-8.0	30.6	30.6	16.2	14.1	4.4	-8.0 h	39.3	39.3	-10,0	40,0	-20,0	50,0
204	4K CDE (ex CEU)	9,3	26.2	24.8	25.5	-10.0	30.7	30.7	16.9	15.5	16.2	-19.3	40.0	40.0	-10,0	40,0	-20,0	50,0
205	REU	9,2	20.7	19.2	20.0	-9.1	25.3	25.3	11.5	10.0	10.8	-9.1 h	34.5	34.5	-10,0	40,0	-20,0	50,0
211	4K CCU Compress.1	11	44.0	42.9	43.5	-4.4	47.9	47.9	33.0	31.9	32.5	-15.4	58.9	58.9				
212	4K CCU Compress.2	10,5	38.6	37.4	38.0	-4.9	42.6	42.5	28.1	26.9	27.5	-15.4	53.1	53.0				
219	4K CCU I/F Bckt -X	9,1	14.6	13.4	14.1	-4.8	18.6	18.6	5.5	4.3	5.0	-4.8 h	27.7	27.7	-10,0	40,0	-20,0	40,0
220	4K CCU I/F Bckt +X	8,6	7.9	6.8	7.4	-7.4	11.8	11.8	7.9 h	6.8 h	7.4 h	-7.4 h	20.4	20.4	-10,0	40,0	-20,0	40,0
221	4K CCU I/F Strap -Z	9,9	22.5	21.4	22.0	-3.5	26.4	26.4	12.6	11.5	12.1	-3.5 h	36.3	36.3	-10,0	40,0	-20,0	40,0
222	4K CCU I/F Strap +Z	9,8	20.4	19.3	19.9	-5.8	24.3	24.3	10.6	9.5	10.1	-5.8 h	34.1	34.1	-10,0	40,0	-20,0	40,0
401	SCE1	9,3	-9.2	-9.3	-9.3	-15.7	-3.2	-8.9	-9.2 h	-9.3 h	-9.3 h	-15.7 h	-3.2 h	-8.9 h	-10,0	40,0	-20,0	50,0
402	SCE2	9,3	-11.9	-12.0	-11.9	-15.4	-8.1	-4.5	-11.9 h	-12.0 h	-11.9 h	-15.4 h	-8.1 h	-4.5 h	-10,0	40,0	-20,0	50,0
519	BEU	9,2	13.2	-1.2	8.5	-7.2	21.1	21.2	4.0	-10.4	-0.7	-16.4	30.3	30.4	-20,0	40,0	-30,0	50,0
520	BEU	9,3	10.6	-5.5	7.2	-10.3	18.3	18.3	1.3	-14.8	-2.1	-19.6	27.6	27.6	-20,0	40,0	-30,0	50,0
521	BEU	9,2	13.8	-2.8	10.7	-7.4	21.7	21.8	4.6	-12.0	1.5	-16.6	30.9	31.0	-20,0	40,0	-30,0	50,0
522	PAU	8,6	11.1	3.3	-0.4	-9.0	18.7	18.7	2.5	-5.3	-9.0	-9.0 h	27.3	27.3	-10,0	30,0	-20,0	50,0

Controlled Distribution

REFERENCE : H-P-RP-AI-0040

DATE : 29/SEP/06

ISSUE : 06

Page : 217/405



NODE	LABEL	UFP													TEMPERATURE LIMIT			
			CASE A1	CASE A2	CASE A3	CASE C	CASE B1	CASE B2	CASE A1	CASE A2	CASE A3	CASE C	CASE B1	CASE B2	MIN	MAX	MIN	MAX
			Min	Min	Min	Min	Max	Max	Tmin - UFP	Tmin - UFP	Tmin - UFP	Tmin - UFP	Tmax +UFP	Tmax +UFP	OPER.	OPER.	N. OP.	N. OP.
525	DAE POWER BOX	8,1	25.6	10.7	24.1	6.0	33.8	33.8	17.5	2.6	16.0	-2.1	41.9	41.9	-20,0	50,0	-30,0	50,0
601	XPND_1	8,3	7.9	6.9	7.5	13.4	17.2	17.2	-0.4	-1.4	-0.8	5.1	25.5	25.5	-10,0	50,0	-20,0	60,0
602	XPND_2	7,9	3.7	2.6	3.3	5.4	10.3	10.1	-4.2	-5.3	-4.7	-2.5	18.2	18.0	-10,0	50,0	-20,0	60,0
603	TWTA_1 BODY	8,8	-10.9	-12.1	-11.4	29.5	32.7	32.7	-19.7	-20.9	-20.2	20.7	41.5	41.5	-20,0	60,0	-30,0	70,0
608	TWTA_1 HEAD	8,8	-10.1	-11.3	-10.6	45.3	48.4	48.4	-18.9	-20.1	-19.4	36.5	57.2	57.2	-20,0	60,0	-30,0	70,0
604	TWTA_2 BODY	7,7	-14.5	-15.7	-15.0	-8.5	-4.4	-4.4	-22.2	-23.4	-22.7	-16.2	3.3	3.3	-20,0	60,0	-30,0	70,0
609	TWTA_2 HEAD	7,7	-14.2	-15.5	-14.7	-8.4	-4.2	-4.3	-21.9	-23.2	-22.4	-16.1	3.5	3.4	-20,0	60,0	-30,0	70,0
605	RFDN	7,9	-3.7	-5.0	-4.2	7.1	11.4	11.4	-11.6	-12.9	-12.1	-0.8	19.3	19.3	-25,0	55,0	-35,0	65,0
606	EPC1	8,3	-2.8	-3.8	-3.2	11.8	15.8	15.8	-11.1	-12.1	-11.5	3.5	24.1	24.1	-20,0	60,0	-30,0	70,0
607	EPC2	7,7	-5.7	-6.7	-6.1	-3.8	1.2	0.8	-13.4	-14.4	-13.8	-11.5	8.9	8.5	-20,0	60,0	-30,0	70,0
701	CDMU	8,1	14.5	12.7	13.8	9.8	20.2	20.1	6.4	4.6	5.7	1.7	28.3	28.2	-10,0	45,0	-20,0	55,0
702	ACC	8	7.2	5.4	6.5	2.1	12.5	12.5	-0.8	-2.6	-1.5	-5.9	20.5	20.5	-10,0	45,0	-20,0	55,0
703	BATT	8	11.5	9.9	10.9	7.4	19.7	19.6	3.5	1.9	2.9	-0.6	27.7	27.6	0,0	35,0	N/A	N/A
704	PCDU	8,7	28.0	26.6	27.4	19.8	33.8	33.8	19.3	17.9	18.7	11.1	42.5	42.5	-10,0	45,0	-20,0	55,0
705	CRS1	8,6	47.9	47.9	47.9	47.9	48.6	48.6	47.9 h	47.9 h	47.9 h	47.9 h	48.6 h	48.6 h	0,0	50,0	-25,0	55,0
706	CRS2	8,7	47.9	47.9	47.9	47.9	48.6	48.6	47.9 h	47.9 h	47.9 h	47.9 h	48.6 h	48.6 h	0,0	50,0	-25,0	55,0
707	CRS3	8,7	34.9	34.9	34.9	34.9	35.6	35.6	34.9 h	34.9 h	34.9 h	34.9 h	35.6 h	35.6 h	0,0	50,0	-25,0	55,0
900	Helium Tank +Z	7,8	10.8	7.9	8.8	-0.4	18.1	18.2	10.8	7.9	8.8	-0.4	25.9	26.0	-10,0	40,0	-20,0	50,0
905	Helium Tank +Y	8,3	9.9	7.7	9.0	-3.0	16.6	16.6	9.9	7.7	9.0	-3.0	24.9	24.9	-10,0	40,0	-20,0	50,0
910	Helium Tank -Z	7,9	-0.9	-3.2	-2.2	-6.0	5.6	5.9	-0.9	-3.2	-2.2	-6.0	13.5	13.8	-10,0	40,0	-20,0	50,0
915	Helium Tank -Y	8	6.2	4.8	5.7	10.9	15.6	15.5	-1.8	-3.2	-2.3	2.9	23.6	23.5	-10,0	40,0	-20,0	50,0
916	Helium Tank -Y	8	8.8	7.1	8.1	12.4	17.8	17.8	0.8	-0.9	0.1	4.4	25.8	25.8	-10,0	40,0	-20,0	50,0
917	Helium Tank -Y	8	14.1	12.2	13.3	14.2	21.7	21.7	6.1	4.2	5.3	6.2	29.7	29.7	-10,0	40,0	-20,0	50,0
918	Helium Tank -Y	8	13.4	11.9	12.8	14.7	20.5	20.4	5.4	3.9	4.8	6.7	28.5	28.4	-10,0	40,0	-20,0	50,0

Controlled Distribution

REFERENCE : H-P-RP-AI-0040

DATE : 29/SEP/06

ISSUE : 06

Page : 218/405



NODE	LABEL	UFP	CASE A1	CASE A2	CASE A3	CASE C	CASE B1	CASE B2	CASE A1	CASE A2	CASE A3	CASE C	CASE B1	CASE B2	TEMPERATURE LIMIT			
															MIN	MAX	MIN	MAX
															OPER.	OPER.	N. OP.	N. OP.
920	Prop. Tank +Y+Z Lower	8	19.2	15.5	17.6	11.0	27.6	27.6	11.2 h	15.5 h	17.6 h	11.0 h	35.6 h	35.6 h	10,0	50,0	10,0	50,0
925	Prop. Tank -Z Lower	8,1	19.2	13.7	16.5	11.0	28.7	28.7	11.1 h	13.7 h	16.5 h	11.0 h	36.8 h	36.8 h	10,0	50,0	10,0	50,0
930	Prop. Tank -Y+Z Lower	8	19.6	16.1	18.2	13.7	27.8	27.8	11.6 h	16.1 h	18.2 h	13.7 h	35.8 h	35.8 h	10,0	50,0	10,0	50,0
311	SCC1 - Outer shell1	9,9	-10,0	-10,0	-10,0	-15,6	21,9	-8,4	-10,0 h	-10,0 h	-10,0 h	-15,6 h	21,9 h	-8,4 h				
312	SCC1 - Outer shell2	9,9	-10,0	-10,0	-10,0	-15,6	22,0	-8,5	-10,0 h	-10,0 h	-10,0 h	-15,6 h	22,0 h	-8,5 h				
313	SCC1 - Outer shell3	9,9	-10,0	-10,0	-10,0	-15,6	22,0	-8,5	-10,0 h	-10,0 h	-10,0 h	-15,6 h	22,0 h	-8,5 h				
314	SCC1 - Outer shell4	9,9	-10,0	-10,0	-10,0	-15,6	21,9	-8,5	-10,0 h	-10,0 h	-10,0 h	-15,6 h	21,9 h	-8,5 h				
315	SCC1 - Outer shell5	9,9	-10,0	-10,0	-10,0	-15,6	22,0	-8,5	-10,0 h	-10,0 h	-10,0 h	-15,6 h	22,0 h	-8,5 h				
316	SCC1 - Outer shell6	9,9	-10,0	-10,0	-10,0	-15,6	22,0	-8,4	-10,0 h	-10,0 h	-10,0 h	-15,6 h	22,0 h	-8,4 h				
811	HP11 Ver. SCC1	9,7	-10,4	-10,4	-10,4	-15,6	-1,6	-8,4	-10,4 h	-10,4 h	-10,4 h	-15,6 h	-1,6 h	-8,4 h	-13,0	7,0	-20,0	50,0
812	HP12 Ver. SCC1	9,7	-10,0	-10,1	-10,0	-15,6	0,1	-8,4	-10,0 h	-10,1 h	-10,0 h	-15,6 h	0,1 h	-8,4 h	-13,0	7,0	-20,0	50,0
813	HP13 Ver. SCC1	9,7	-10,0	-10,1	-10,0	-15,6	0,1	-8,4	-10,0 h	-10,1 h	-10,0 h	-15,6 h	0,1 h	-8,4 h	-13,0	7,0	-20,0	50,0
814	HP14 Ver. SCC1	9,7	-10,0	-10,1	-10,0	-15,6	0,1	-8,4	-10,0 h	-10,1 h	-10,0 h	-15,6 h	0,1 h	-8,4 h	-13,0	7,0	-20,0	50,0
815	HP15 Ver. SCC1	9,7	-10,0	-10,1	-10,0	-15,6	0,1	-8,4	-10,0 h	-10,1 h	-10,0 h	-15,6 h	0,1 h	-8,4 h	-13,0	7,0	-20,0	50,0
816	HP16 Ver. SCC1	9,7	-10,0	-10,1	-10,0	-15,6	0,1	-8,4	-10,0 h	-10,1 h	-10,0 h	-15,6 h	0,1 h	-8,4 h	-13,0	7,0	-20,0	50,0
817	HP17 Ver. SCC1	9,7	-10,0	-10,1	-10,0	-15,6	0,1	-8,4	-10,0 h	-10,1 h	-10,0 h	-15,6 h	0,1 h	-8,4 h	-13,0	7,0	-20,0	50,0
818	HP18 Ver. SCC1	9,7	-10,0	-10,1	-10,0	-15,6	0,1	-8,4	-10,0 h	-10,1 h	-10,0 h	-15,6 h	0,1 h	-8,4 h	-13,0	7,0	-20,0	50,0
819	HP19 Ver. SCC1	9,7	-10,0	-10,1	-10,0	-15,6	0,1	-8,4	-10,0 h	-10,1 h	-10,0 h	-15,6 h	0,1 h	-8,4 h	-13,0	7,0	-20,0	50,0
820	HP20 Ver. SCC1	9,7	-10,0	-10,1	-10,0	-15,6	0,1	-8,4	-10,0 h	-10,1 h	-10,0 h	-15,6 h	0,1 h	-8,4 h	-13,0	7,0	-20,0	50,0
821	HP21 Ver. SCC1	9,7	-10,0	-10,1	-10,0	-15,6	0,1	-8,4	-10,0 h	-10,1 h	-10,0 h	-15,6 h	0,1 h	-8,4 h	-13,0	7,0	-20,0	50,0
822	HP22 Ver. SCC1	9,7	-10,0	-10,1	-10,0	-15,6	0,1	-8,4	-10,0 h	-10,1 h	-10,0 h	-15,6 h	0,1 h	-8,4 h	-13,0	7,0	-20,0	50,0
823	HP23 Ver. SCC1	9,7	-10,0	-10,1	-10,0	-15,6	0,1	-8,4	-10,0 h	-10,1 h	-10,0 h	-15,6 h	0,1 h	-8,4 h	-13,0	7,0	-20,0	50,0
824	HP24 Ver. SCC1	9,7	-10,0	-10,1	-10,0	-15,6	0,1	-8,4	-10,0 h	-10,1 h	-10,0 h	-15,6 h	0,1 h	-8,4 h	-13,0	7,0	-20,0	50,0
825	HP25 Ver. SCC1	9,7	-10,0	-10,1	-10,0	-15,6	0,1	-8,4	-10,0 h	-10,1 h	-10,0 h	-15,6 h	0,1 h	-8,4 h	-13,0	7,0	-20,0	50,0

Controlled Distribution

REFERENCE : H-P-RP-AI-0040

DATE : 29/SEP/06

ISSUE : 06

Page : 219/405



NODE	LABEL	UFP	CASE A1	CASE A2	CASE A3	CASE C	CASE B1	CASE B2	CASE A1	CASE A2	CASE A3	CASE C	CASE B1	CASE B2	TEMPERATURE LIMIT									
															MIN	MAX	MIN	MAX						
															OPER.	OPER.	N. OP.	N. OP.						
826	HP26 Ver. SCC1	9,7	-10,4	-10,4	-10,4	-15,6	-1,6	-8,4	-10,4	h	-10,4	h	-10,4	h	-15,6	h	-1,6	h	-8,4	h	-13,0	7,0	-20,0	50,0
801	HP1 Hor. SCC1	9,3	-11,4	-11,5	-11,4	-15,4	-6,3	-7,8	-11,4	h	-11,5	h	-11,4	h	-15,4	h	-6,3	h	-7,8	h				
802	HP2 Hor. SCC1	9,3	-10,9	-10,9	-10,9	-15,4	-5,8	-8,3	-10,9	h	-10,9	h	-10,9	h	-15,4	h	-5,8	h	-8,3	h				
803	HP3 Hor. SCC1	9,3	-11,8	-11,9	-11,9	-15,9	-6,2	-9,1	-11,8	h	-11,9	h	-11,9	h	-15,9	h	-6,2	h	-9,1	h				
804	HP4 Hor. SCC1	9,3	-11,5	-11,5	-11,5	-16,1	-6,3	-9,1	-11,5	h	-11,5	h	-11,5	h	-16,1	h	-6,3	h	-9,1	h				
805	HP5 Hor. SCC1	9,3	-12,4	-12,5	-12,4	-16,0	-7,8	-8,9	-12,4	h	-12,5	h	-12,4	h	-16,0	h	-7,8	h	-8,9	h				
806	HP6 Hor. SCC1	9,3	-12,7	-12,7	-12,7	-15,5	-8,0	-7,7	-12,7	h	-12,7	h	-12,7	h	-15,5	h	-8,0	h	-7,7	h				
807	HP7 Hor. SCC1	9,3	-12,3	-12,3	-12,3	-15,7	-7,9	-7,6	-12,3	h	-12,3	h	-12,3	h	-15,7	h	-7,9	h	-7,6	h				
808	HP7 Hor. SCC1	9,3	-12,1	-12,2	-12,2	-15,1	-7,8	-7,3	-12,1	h	-12,2	h	-12,2	h	-15,1	h	-7,8	h	-7,3	h				
511	SCC2 - Outer shell1	9,1	-12,8	-12,9	-12,9	-14,9	-10,2	23,8	-12,8	h	-12,9	h	-12,9	h	-14,9	h	-10,2	h	23,8	h				
512	SCC2 - Outer shell2	9,1	-12,8	-12,9	-12,9	-14,9	-10,2	23,8	-12,8	h	-12,9	h	-12,9	h	-14,9	h	-10,2	h	23,8	h				
513	SCC2 - Outer shell3	9,1	-12,8	-12,9	-12,9	-14,9	-10,2	23,8	-12,8	h	-12,9	h	-12,9	h	-14,9	h	-10,2	h	23,8	h				
514	SCC2 - Outer shell4	9,1	-12,8	-12,9	-12,9	-14,9	-10,2	23,8	-12,8	h	-12,9	h	-12,9	h	-14,9	h	-10,2	h	23,8	h				
515	SCC2 - Outer shell5	9,1	-12,8	-12,9	-12,9	-14,9	-10,2	23,8	-12,8	h	-12,9	h	-12,9	h	-14,9	h	-10,2	h	23,8	h				
516	SCC2 - Outer shell6	9,1	-12,8	-12,9	-12,9	-14,9	-10,2	23,8	-12,8	h	-12,9	h	-12,9	h	-14,9	h	-10,2	h	23,8	h				
861	HP61 Ver. SCC2	9,7	-12,9	-13,0	-12,9	-14,9	-10,2	0,6	-12,9	h	-13,0	h	-12,9	h	-14,9	h	-10,2	h	0,6	h	-13,0	7,0	-20,0	50,0
862	HP62 Ver. SCC2	9,7	-12,9	-12,9	-12,9	-14,9	-10,2	2,2	-12,9	h	-12,9	h	-12,9	h	-14,9	h	-10,2	h	2,2	h	-13,0	7,0	-20,0	50,0
863	HP63 Ver. SCC2	9,7	-12,9	-12,9	-12,9	-14,9	-10,2	2,2	-12,9	h	-12,9	h	-12,9	h	-14,9	h	-10,2	h	2,2	h	-13,0	7,0	-20,0	50,0
864	HP64 Ver. SCC2	9,7	-12,9	-12,9	-12,9	-14,9	-10,2	2,2	-12,9	h	-12,9	h	-12,9	h	-14,9	h	-10,2	h	2,2	h	-13,0	7,0	-20,0	50,0
865	HP65 Ver. SCC2	9,7	-12,9	-12,9	-12,9	-14,9	-10,2	2,2	-12,9	h	-12,9	h	-12,9	h	-14,9	h	-10,2	h	2,2	h	-13,0	7,0	-20,0	50,0
866	HP66 Ver. SCC2	9,7	-12,9	-12,9	-12,9	-14,9	-10,2	2,2	-12,9	h	-12,9	h	-12,9	h	-14,9	h	-10,2	h	2,2	h	-13,0	7,0	-20,0	50,0
867	HP67 Ver. SCC2	9,7	-12,9	-12,9	-12,9	-17,2	-10,2	1,1	-12,9	h	-12,9	h	-12,9	h	-17,2	h	-10,2	h	1,1	h	-13,0	7,0	-20,0	50,0
868	HP68 Ver. SCC2	9,7	-12,9	-12,9	-12,9	-17,2	-10,2	1,1	-12,9	h	-12,9	h	-12,9	h	-17,2	h	-10,2	h	1,1	h	-13,0	7,0	-20,0	50,0
869	HP69 Ver. SCC2	9,7	-12,9	-12,9	-12,9	-17,2	-10,2	1,1	-12,9	h	-12,9	h	-12,9	h	-17,2	h	-10,2	h	1,1	h	-13,0	7,0	-20,0	50,0

Controlled Distribution

REFERENCE : H-P-RP-AI-0040

DATE : 29/SEP/06

ISSUE : 06

Page : 220/405



NODE	LABEL	UFP															TEMPERATURE LIMIT							
			CASE A1	CASE A2	CASE A3	CASE C	CASE B1	CASE B2	CASE A1	CASE A2	CASE A3	CASE C	CASE B1	CASE B2	MIN	MAX	MIN	MAX						
			Min	Min	Min	Min	Max	Max	Tmin - UFP	Tmin - UFP	Tmin - UFP	Tmin - UFP	Tmax +UFP	Tmax +UFP	OPER.	OPER.	N. OP.	N. OP.						
870	HP70 Ver. SCC2	9,7	-12,9	-12,9	-12,9	-17,2	-10,2	1,1	-12,9	h	-12,9	h	-12,9	h	-17,2	h	-10,2	h	1,1	h	-13,0	7,0	-20,0	50,0
871	HP71 Ver. SCC2	9,7	-12,9	-12,9	-12,9	-17,2	-10,2	1,1	-12,9	h	-12,9	h	-12,9	h	-17,2	h	-10,2	h	1,1	h	-13,0	7,0	-20,0	50,0
872	HP72 Ver. SCC2	9,7	-12,9	-12,9	-12,9	-14,9	-10,2	2,2	-12,9	h	-12,9	h	-12,9	h	-14,9	h	-10,2	h	2,2	h	-13,0	7,0	-20,0	50,0
873	HP73 Ver. SCC2	9,7	-12,9	-12,9	-12,9	-14,9	-10,2	2,2	-12,9	h	-12,9	h	-12,9	h	-14,9	h	-10,2	h	2,2	h	-13,0	7,0	-20,0	50,0
874	HP74 Ver. SCC2	9,7	-12,9	-12,9	-12,9	-14,9	-10,2	2,2	-12,9	h	-12,9	h	-12,9	h	-14,9	h	-10,2	h	2,2	h	-13,0	7,0	-20,0	50,0
875	HP75 Ver. SCC2	9,7	-12,9	-12,9	-12,9	-14,9	-10,2	2,2	-12,9	h	-12,9	h	-12,9	h	-14,9	h	-10,2	h	2,2	h	-13,0	7,0	-20,0	50,0
876	HP76 Ver. SCC2	9,7	-12,9	-13,0	-12,9	-14,9	-10,2	0,6	-12,9	h	-13,0	h	-12,9	h	-14,9	h	-10,2	h	0,6	h	-13,0	7,0	-20,0	50,0
851	HP51 Hor. SCC2	9,1	-11,8	-11,9	-11,9	-13,7	-9,4	-4,0	-11,8	h	-11,9	h	-11,9	h	-13,7	h	-9,4	h	-4,0	h				
852	HP52 Hor. SCC2	9,1	-12,8	-12,9	-12,9	-14,6	-9,4	-4,4	-12,8	h	-12,9	h	-12,9	h	-14,6	h	-9,4	h	-4,4	h				
853	HP53 Hor. SCC2	9,1	-13,4	-13,5	-13,5	-15,3	-9,8	-4,9	-13,4	h	-13,5	h	-13,5	h	-15,3	h	-9,8	h	-4,9	h				
854	HP54 Hor. SCC2	9,1	-12,3	-12,4	-12,3	-15,4	-9,9	-5,0	-12,3	h	-12,4	h	-12,3	h	-15,4	h	-9,9	h	-5,0	h				
855	HP55 Hor. SCC2	9,1	-13,7	-13,8	-13,8	-14,5	-10,5	-5,0	-13,7	h	-13,8	h	-13,8	h	-14,5	h	-10,5	h	-5,0	h				
856	HP56 Hor. SCC2	9,1	-13,7	-13,8	-13,8	-15,9	-10,6	-4,5	-13,7	h	-13,8	h	-13,8	h	-15,9	h	-10,6	h	-4,5	h				
857	HP57 Hor. SCC2	9,1	-12,6	-12,7	-12,7	-15,0	-10,5	-4,4	-12,6	h	-12,7	h	-12,7	h	-15,0	h	-10,5	h	-4,4	h				
858	HP57 Hor. SCC2	9,1	-13,6	-13,6	-13,6	-14,8	-10,4	-4,3	-13,6	h	-13,6	h	-13,6	h	-14,8	h	-10,4	h	-4,3	h				
3931	SAS1 HOUSING	9,2	6,0	4,7	5,4	-18,2	9,9	9,9	-3,2		-4,5	-3,8	-27,4	19,1	19,1					-70,0	80,0	-80,0	90,0	
3951	SAS2 HOUSING	7,5	49,2	47,1	48,2	45,1	62,2	62,2	41,7		39,6	40,7	37,6	69,7	69,7					-70,0	80,0	-80,0	90,0	
3921	LGA+Y HORN	8,3	-42,0	-42,7	-42,3	-24,7	-39,7	-39,7	-50,3		-51,0	-50,6	-33,0	-31,4	-31,4					-150,0	120,0	-150,0	120,0	
3961	LGA-Y HORN	8,2	-71,9	-72,4	-72,1	-34,4	-68,5	-68,7	-80,1		-80,6	-80,3	-42,6	-60,3	-60,5					-150,0	120,0	-150,0	120,0	
3991	LGA-X HORN	7,2	81,6	81,4	81,5	82,0	90,0	90,0	74,4		74,2	74,3	74,8	97,2	97,2					-150,0	120,0	-150,0	120,0	
3986	MGA-X SEPTUM	8,5	70,8	68,4	69,7	67,3	121,2	121,1	62,3		59,9	61,2	58,8	129,7	129,6					-150,0	150,0	-150,0	150,0	
3966	SREM	8,2	9,5	7,2	8,1	-8,4	15,9	15,9	1,3		-1,0	-0,1	-16,6	24,1	24,1					-10,0	50,0	-45,0	90,0	
3970	AAD_HOUSING	8,8	40,5	38,2	39,4	35,8	52,6	52,6	31,7		29,4	30,6	27,0	61,4	61,4					-70,0	70,0	-80,0	80,0	
8508	1FCV BODY A1A	7,9	15,8	14,7	20,1	13,9	18,9	18,9	15,8	h	14,7	h	20,1	h	13,9	h	26,8	h	26,8	h	10,0	60,0	10,0	70,0

Controlled Distribution

REFERENCE : H-P-RP-AI-0040

DATE : 29/SEP/06

ISSUE : 06

Page : 221/405



NODE	LABEL	UFP													TEMPERATURE LIMIT									
			CASE A1	CASE A2	CASE A3	CASE C	CASE B1	CASE B2	CASE A1	CASE A2	CASE A3	CASE C	CASE B1	CASE B2	MIN	MAX	MIN	MAX						
			Min	Min	Min	Min	Max	Max	Tmin - UFP	Tmin - UFP	Tmin - UFP	Tmin - UFP	Tmax +UFP	Tmax +UFP	OPER.	OPER.	N. OP.	N. OP.						
8608	1FCV BODY A1B	7,8	14,0	13,9	14,0	13,9	21,2	21,1	14,0	h	13,9	h	14,0	h	13,9	h	21,2	h	28,9	h	10,0	60,0	10,0	70,0
8708	1FCV BODY B1A	8	19,0	18,5	23,7	14,0	24,0	23,9	19,0	h	18,5	h	23,7	h	14,0	h	32,0	h	31,9	h	10,0	60,0	10,0	70,0
8808	1FCV BODY B1B	8	14,4	14,0	14,6	14,0	19,6	19,4	14,4	h	14,0	h	14,6	h	14,0	h	27,6	h	27,4	h	10,0	60,0	10,0	70,0
1133	FCV BODY MAIN D1A	7,8	46,1	44,8	45,3	45,9	51,8	51,8	46,1	h	44,8	h	45,3	h	45,9	h	59,6	h	59,6	h	10,0	60,0	10,0	70,0
1134	FCV BODY RED. D1B	7,9	45,8	44,5	45,1	41,2	51,0	51,0	45,8	h	44,5	h	45,1	h	41,2	h	58,9	h	58,9	h	10,0	60,0	10,0	70,0
1233	FCV BODY MAIN D2A	7,6	39,7	39,5	39,6	47,2	46,9	46,5	39,7	h	39,5	h	39,6	h	47,2	h	54,5	h	54,1	h	10,0	60,0	10,0	70,0
1234	FCV BODY RED. D2B	7,7	38,9	38,6	38,8	41,5	46,8	46,4	38,9	h	38,6	h	38,8	h	41,5	h	54,5	h	54,1	h	10,0	60,0	10,0	70,0
1333	FCV BODY MAIN F1A	7,9	36,5	35,8	36,2	45,6	42,0	41,8	36,5	h	35,8	h	36,2	h	45,6	h	49,9	h	49,7	h	10,0	60,0	10,0	70,0
1334	FCV BODY RED. F1B	8	38,1	37,4	37,9	40,4	42,7	42,4	38,1	h	37,4	h	37,9	h	40,4	h	50,7	h	50,4	h	10,0	60,0	10,0	70,0
1433	FCV BODY MAIN F2A	8,1	32,7	31,4	30,4	29,3	37,1	37,1	32,7	h	31,4	h	30,4	h	29,3	h	45,2	h	45,2	h	10,0	60,0	10,0	70,0
1434	FCV BODY RED. F2B	7,9	32,2	30,9	29,9	23,2	36,6	36,6	32,2	h	30,9	h	29,9	h	23,2	h	44,5	h	44,5	h	10,0	60,0	10,0	70,0
1533	FCV BODY MAIN U1A	9,2	14,0	14,0	14,0	14,9	16,2	16,1	14,0	h	14,0	h	14,0	h	14,9	h	25,4	h	25,3	h	10,0	60,0	10,0	70,0
1534	FCV BODY RED. U1B	9,3	14,0	14,0	14,0	14,0	16,0	16,0	14,0	h	14,0	h	14,0	h	14,0	h	25,3	h	25,3	h	10,0	60,0	10,0	70,0
1733	FCV BODY MAIN U2A	8,8	14,0	14,0	14,0	19,6	21,0	21,0	14,0	h	14,0	h	14,0	h	19,6	h	29,8	h	29,8	h	10,0	60,0	10,0	70,0
1734	FCV BODY RED. U2B	8,8	14,0	14,0	14,0	14,0	21,0	21,0	14,0	h	14,0	h	14,0	h	14,0	h	29,8	h	29,8	h	10,0	60,0	10,0	70,0
1800	RCS LINE #33	8	23,2	23,6	23,3	23,7	25,8	25,8	15,2	h	15,6	h	15,3	h	15,7	h	33,8	h	33,8	h	10,0	50,0		
1801	RCS LINE #33	8	23,2	23,6	23,3	23,7	25,8	25,8	15,2	h	15,6	h	15,3	h	15,7	h	33,8	h	33,8	h	10,0	50,0		
1802	RCS LINE #33	8	23,2	23,6	23,3	23,7	25,8	25,8	15,2	h	15,6	h	15,3	h	15,7	h	33,8	h	33,8	h	10,0	50,0		
1803	RCS LINE #33	8	23,2	23,6	23,3	23,7	25,8	25,8	15,2	h	15,6	h	15,3	h	15,7	h	33,8	h	33,8	h	10,0	50,0		
1804	RCS LINE #33	8	23,2	23,6	23,3	23,7	25,8	25,8	15,2	h	15,6	h	15,3	h	15,7	h	33,8	h	33,8	h	10,0	50,0		
1805	RCS LINE #33	8	24,2	25,4	25,7	24,9	25,2	25,2	16,2	h	17,4	h	17,7	h	16,9	h	33,2	h	33,2	h	10,0	50,0		
1806	RCS LINE #33	8	22,0	23,8	22,4	23,4	22,9	22,9	14,0	h	15,8	h	14,4	h	15,4	h	30,9	h	30,9	h	10,0	50,0		
1807	RCS LINE #33	8	21,3	23,1	21,3	23,5	22,0	22,0	13,3	h	15,1	h	13,3	h	15,5	h	30,0	h	30,0	h	10,0	50,0		
1808	RCS LINE #33	8	23,6	25,8	22,7	25,6	23,1	23,1	15,6	h	17,8	h	14,7	h	17,6	h	31,1	h	31,1	h	10,0	50,0		

Controlled Distribution

REFERENCE : H-P-RP-AI-0040

DATE : 29/SEP/06

ISSUE : 06

Page : 222/405



NODE	LABEL	UFP	CASE	CASE	CASE	CASE	CASE	CASE	CASE	CASE	CASE	CASE	CASE	CASE	TEMPERATURE LIMIT									
			A1	A2	A3	C	B1	B2	A1	A2	A3	C	B1	B2	MIN	MAX	MIN	MAX						
			Min	Min	Min	Min	Max	Max	Tmin - UFP	Tmin - UFP	Tmin - UFP	Tmin - UFP	Tmax +UFP	Tmax +UFP	OPER.	OPER.	N. OP.	N. OP.						
1809	RCS LINE #33	8	33,6	34,3	32,2	34,0	36,4	36,4	25,6	h	26,3	h	24,2	h	26,0	h	44,4	h	44,4	h	10,0	50,0		
1810	RCS LINE #33	8	23,1	21,4	22,5	20,5	28,3	28,3	15,1	h	13,4	h	14,5	h	12,5	h	36,3	h	36,3	h	10,0	50,0		
1811	RCS LINE #33	8	22,9	22,7	22,9	21,9	24,0	24,1	14,9	h	14,7	h	14,9	h	13,9	h	32,0	h	32,1	h	10,0	50,0		
1812	RCS LINE #33	8	23,0	23,0	23,0	21,7	24,1	24,1	15,0	h	15,0	h	15,0	h	13,7	h	32,1	h	32,1	h	10,0	50,0		
1813	RCS LINE #33	8	23,3	23,5	23,3	22,0	24,5	24,5	15,3	h	15,5	h	15,3	h	14,0	h	32,5	h	32,5	h	10,0	50,0		
1814	RCS LINE #33	8	23,9	22,6	23,4	22,6	29,4	29,4	15,9	h	14,6	h	15,4	h	14,6	h	37,4	h	37,4	h	10,0	50,0		
1815	RCS LINE #33	8	25,5	26,6	26,0	29,6	29,7	29,7	17,5	h	18,6	h	18,0	h	21,6	h	37,7	h	37,7	h	10,0	50,0		
1816	RCS LINE #33	8	24,8	25,5	25,0	25,7	25,3	25,3	16,8	h	17,5	h	17,0	h	17,7	h	33,3	h	33,3	h	10,0	50,0		
1817	RCS LINE #34	8	25,6	26,3	25,6	20,8	28,8	28,8	17,6	h	18,3	h	17,6	h	12,8	h	36,8	h	36,8	h	10,0	50,0		
1818	RCS LINE #34	8	28,2	29,6	28,5	27,4	29,7	29,7	20,2	h	21,6	h	20,5	h	19,4	h	37,7	h	37,7	h	10,0	50,0		
1819	RCS LINE #34	8	27,5	28,2	27,7	26,1	28,4	28,4	19,5	h	20,2	h	19,7	h	18,1	h	36,4	h	36,4	h	10,0	50,0		
1820	RCS LINE #34	8	26,5	26,5	26,5	25,3	28,3	28,3	18,5	h	18,5	h	18,5	h	17,3	h	36,3	h	36,3	h	10,0	50,0		
1821	RCS LINE #34	8	28,6	29,2	28,9	28,1	27,9	27,9	20,6	h	21,2	h	20,9	h	20,1	h	35,9	h	35,9	h	10,0	50,0		
1822	RCS LINE #34	8	28,6	29,1	28,8	28,1	27,9	28,0	20,6	h	21,1	h	20,8	h	20,1	h	35,9	h	36,0	h	10,0	50,0		
1823	RCS LINE #34	8	23,0	22,1	22,7	18,5	26,9	26,9	15,0	h	14,1	h	14,7	h	10,5	h	34,9	h	34,9	h	10,0	50,0		
1824	RCS LINE #34	8	23,0	22,1	22,7	18,5	26,9	26,9	15,0	h	14,1	h	14,7	h	10,5	h	34,9	h	34,9	h	10,0	50,0		
1825	RCS LINE #34	8	23,0	22,1	22,7	18,5	26,9	26,9	15,0	h	14,1	h	14,7	h	10,5	h	34,9	h	34,9	h	10,0	50,0		
1826	RCS LINE #34	8	27,0	27,0	27,0	24,7	27,0	27,0	19,0	h	19,0	h	19,0	h	16,7	h	35,0	h	35,0	h	10,0	50,0		
1827	RCS LINE #34	8	27,0	27,0	27,0	24,7	27,0	27,0	19,0	h	19,0	h	19,0	h	16,7	h	35,0	h	35,0	h	10,0	50,0		
1828	RCS LINE #34	8	27,0	27,0	27,0	24,7	27,0	27,0	19,0	h	19,0	h	19,0	h	16,7	h	35,0	h	35,0	h	10,0	50,0		
1830	RCS LINE #34	8	28,2	29,4	28,5	25,4	26,9	26,9	20,2	h	21,4	h	20,5	h	17,4	h	34,9	h	34,9	h	10,0	50,0		
1831	RCS LINE #34	8	29,0	30,2	29,2	22,1	27,3	27,3	21,0	h	22,2	h	21,2	h	14,1	h	35,3	h	35,3	h	10,0	50,0		
1832	RCS LINE #34	8	27,4	28,2	27,4	20,3	26,7	26,7	19,4	h	20,2	h	19,4	h	12,3	h	34,7	h	34,7	h	10,0	50,0		
1833	RCS LINE #34	8	27,8	28,9	28,0	24,5	26,7	26,7	19,8	h	20,9	h	20,0	h	16,5	h	34,7	h	34,7	h	10,0	50,0		

Controlled Distribution



REFERENCE : H-P-RP-AI-0040

DATE : 29/SEP/06

ISSUE : 06

Page : 223/405

NODE	LABEL	UFP	CASE A1	CASE A2	CASE A3	CASE C	CASE B1	CASE B2	CASE A1	CASE A2	CASE A3	CASE C	CASE B1	CASE B2	TEMPERATURE LIMIT															
															Min	Min	Min	Min	Max	Max	Tmin - UFP	Tmin - UFP	Tmin - UFP	Tmin - UFP	Tmax +UFP	Tmax +UFP	MIN	MAX	MIN	MAX
															OPER.	OPER.	N. OP.	N. OP.												
1835	RCS LINE #34	8	32,0	33,9	32,5	30,1	27,0	27,0	24,0	h	25,9	h	24,5	h	22,1	h	35,0	h	35,0	h	10,0	50,0								
1836	RCS LINE #34	8	29,5	30,8	29,7	24,1	27,3	27,3	21,5	h	22,8	h	21,7	h	16,1	h	35,3	h	35,3	h	10,0	50,0								
1837	RCS LINE #34	8	27,2	28,0	27,3	22,1	26,4	26,4	19,2	h	20,0	h	19,3	h	14,1	h	34,4	h	34,4	h	10,0	50,0								
1838	RCS LINE #34	8	25,1	24,6	24,9	21,2	26,7	26,7	17,1	h	16,6	h	16,9	h	13,2	h	34,7	h	34,7	h	10,0	50,0								
1839	RCS LINE #34	8	25,7	25,8	25,6	22,4	27,3	27,3	17,7	h	17,8	h	17,6	h	14,4	h	35,3	h	35,3	h	10,0	50,0								
1846	RCS LINE #34	8	25,5	27,3	26,1	24,5	23,0	22,9	17,5	h	19,3	h	18,1	h	16,5	h	31,0	h	30,9	h	10,0	50,0								
1847	RCS LINE #34	8	21,9	24,1	22,7	23,9	19,0	19,0	13,9	h	16,1	h	14,7	h	15,9	h	27,0	h	27,0	h	10,0	50,0								
1848	RCS LINE #34	8	18,0	19,5	18,7	23,3	18,7	18,7	10,0	h	11,5	h	10,7	h	15,3	h	26,7	h	26,7	h	10,0	50,0								
1949	RCS LINE #34	8	27,0	27,0	27,0	24,8	27,3	27,3	19,0	h	19,0	h	19,0	h	16,8	h	35,3	h	35,3	h	10,0	50,0								
1950	RCS LINE #34	8	27,0	27,0	27,0	24,9	27,4	27,4	19,0	h	19,0	h	19,0	h	16,9	h	35,4	h	35,4	h	10,0	50,0								
1840	RCS LINE #32 - LV1	8	21,3	20,8	21,1	19,7	22,6	22,6	13,3	h	12,8	h	13,1	h	11,7	h	30,6	h	30,6	h	10,0	50,0								
1841	RCS LINE #32 - LV2	8	21,2	20,7	21,0	19,6	22,6	22,6	13,2	h	12,7	h	13,0	h	11,6	h	30,6	h	30,6	h	10,0	50,0								
1842	RCS LINE #32 - LF	8	21,0	20,4	20,7	18,6	22,9	22,9	13,0	h	12,4	h	12,7	h	10,6	h	30,9	h	30,9	h	10,0	50,0								
1843	RCS LINE #32 - PT	8	23,0	23,0	23,0	22,9	23,5	23,5	15,0	h	15,0	h	15,0	h	14,9	h	31,5	h	31,5	h	10,0	50,0								
1844	RCS LINE #46	8	22,6	21,2	22,1	20,3	25,6	25,1	14,6	h	13,2	h	14,1	h	12,3	h	33,6	h	33,1	h	10,0	50,0								
1849	RCS LINE #46	8	22,6	21,2	22,1	20,3	25,6	25,1	14,6	h	13,2	h	14,1	h	12,3	h	33,6	h	33,1	h	10,0	50,0								
1850	RCS LINE #46	8	22,6	21,2	22,1	20,3	25,6	25,1	14,6	h	13,2	h	14,1	h	12,3	h	33,6	h	33,1	h	10,0	50,0								
1851	RCS LINE #46	8	22,6	21,2	22,1	20,3	25,6	25,1	14,6	h	13,2	h	14,1	h	12,3	h	33,6	h	33,1	h	10,0	50,0								
1852	RCS LINE #46	8	22,6	21,2	22,1	20,3	25,6	25,1	14,6	h	13,2	h	14,1	h	12,3	h	33,6	h	33,1	h	10,0	50,0								
1853	RCS LINE #46	8	22,1	20,5	21,6	20,1	25,5	25,1	14,1	h	12,5	h	13,6	h	12,1	h	33,5	h	33,1	h	10,0	50,0								
1854	RCS LINE #46	8	21,7	20,0	21,1	20,4	24,3	26,3	13,7	h	12,0	h	13,1	h	12,4	h	32,3	h	34,3	h	10,0	50,0								
1855	RCS LINE #46	8	39,7	36,6	38,7	36,7	43,5	44,1	31,7	h	28,6	h	30,7	h	28,7	h	51,5	h	52,1	h	10,0	50,0								
1856	RCS LINE #46	8	39,7	36,6	38,7	36,7	43,5	44,1	31,7	h	28,6	h	30,7	h	28,7	h	51,5	h	52,1	h	10,0	50,0								
1857	RCS LINE #46	8	39,7	36,6	38,7	36,7	43,5	44,1	31,7	h	28,6	h	30,7	h	28,7	h	51,5	h	52,1	h	10,0	50,0								

Controlled Distribution

REFERENCE : H-P-RP-AI-0040

DATE : 29/SEP/06

ISSUE : 06

Page : 224/405



NODE	LABEL	UFP	CASE	CASE	CASE	CASE	CASE	CASE	CASE	CASE	CASE	CASE	CASE	CASE	TEMPERATURE LIMIT									
			A1	A2	A3	C	B1	B2	A1	A2	A3	C	B1	B2	MIN	MAX	MIN	MAX						
			Min	Min	Min	Min	Max	Max	Tmin - UFP	Tmin - UFP	Tmin - UFP	Tmin - UFP	Tmax +UFP	Tmax +UFP	OPER.	OPER.	N. OP.	N. OP.						
1858	RCS LINE #46	8	39,7	36,6	38,7	36,7	43,5	44,1	31,7	h	28,6	h	30,7	h	28,7	h	51,5	h	52,1	h	10,0	50,0		
1859	RCS LINE #46	8	39,7	36,6	38,7	36,7	43,5	44,1	31,7	h	28,6	h	30,7	h	28,7	h	51,5	h	52,1	h	10,0	50,0		
1860	RCS LINE #46	8	38,9	35,4	37,7	36,2	43,4	44,0	30,9	h	27,4	h	29,7	h	28,2	h	51,4	h	52,0	h	10,0	50,0		
1861	RCS LINE #46	8	38,9	36,1	37,9	38,1	46,0	46,6	30,9	h	28,1	h	29,9	h	30,1	h	54,0	h	54,6	h	10,0	50,0		
1862	RCS LINE #46	8	28,2	23,5	26,3	22,7	36,8	37,0	20,2	h	15,5	h	18,3	h	14,7	h	44,8	h	45,0	h	10,0	50,0		
1863	RCS LINE #46	8	37,2	34,0	36,2	33,7	41,7	42,1	29,2	h	26,0	h	28,2	h	25,7	h	49,7	h	50,1	h	10,0	50,0		
1864	RCS LINE #46	8	37,2	34,0	36,2	33,7	41,7	42,1	29,2	h	26,0	h	28,2	h	25,7	h	49,7	h	50,1	h	10,0	50,0		
1865	RCS LINE #46	8	37,2	34,0	36,2	33,7	41,7	42,1	29,2	h	26,0	h	28,2	h	25,7	h	49,7	h	50,1	h	10,0	50,0		
1866	RCS LINE #46	8	37,2	34,0	36,2	33,7	41,7	42,1	29,2	h	26,0	h	28,2	h	25,7	h	49,7	h	50,1	h	10,0	50,0		
1867	RCS LINE #46	8	37,2	34,0	36,2	33,7	41,7	42,1	29,2	h	26,0	h	28,2	h	25,7	h	49,7	h	50,1	h	10,0	50,0		
1868	RCS LINE #46	8	37,2	34,0	36,2	33,7	41,7	42,1	29,2	h	26,0	h	28,2	h	25,7	h	49,7	h	50,1	h	10,0	50,0		
1869	RCS LINE #46	8	36,5	32,8	35,1	33,2	41,6	42,1	28,5	h	24,8	h	27,1	h	25,2	h	49,6	h	50,1	h	10,0	50,0		
1870	RCS LINE #46	8	36,5	32,8	35,1	33,2	41,6	42,1	28,5	h	24,8	h	27,1	h	25,2	h	49,6	h	50,1	h	10,0	50,0		
1871	RCS LINE #46	8	36,5	32,8	35,1	33,2	41,6	42,1	28,5	h	24,8	h	27,1	h	25,2	h	49,6	h	50,1	h	10,0	50,0		
1872	RCS LINE #46	8	27,1	21,9	25,1	20,5	34,6	34,8	19,1	h	13,9	h	17,1	h	12,5	h	42,6	h	42,8	h	10,0	50,0		
1873	RCS LINE #46	8	28,6	22,5	26,7	21,1	33,3	33,7	20,6	h	14,5	h	18,7	h	13,1	h	41,3	h	41,7	h	10,0	50,0		
1874	RCS LINE #46	8	30,5	25,0	28,7	23,7	35,7	36,1	22,5	h	17,0	h	20,7	h	15,7	h	43,7	h	44,1	h	10,0	50,0		
1875	RCS LINE #46	8	31,8	27,0	30,1	26,1	37,4	37,8	23,8	h	19,0	h	22,1	h	18,1	h	45,4	h	45,8	h	10,0	50,0		
1876	RCS LINE #46	8	27,6	25,2	26,7	25,2	31,6	31,9	19,6	h	17,2	h	18,7	h	17,2	h	39,6	h	39,9	h	10,0	50,0		
1877	RCS LINE #46	8	18,9	18,9	18,9	18,9	20,2	20,2	10,9	h	10,9	h	10,9	h	10,9	h	28,2	h	28,2	h	10,0	50,0		
1878	RCS LINE #46	8	41,4	41,9	41,6	46,5	44,5	44,4	33,4	h	33,9	h	33,6	h	38,5	h	52,5	h	52,4	h	10,0	50,0		
1879	RCS LINE #46	8	40,3	40,4	40,3	45,3	46,5	46,3	32,3	h	32,4	h	32,3	h	37,3	h	54,5	h	54,3	h	10,0	50,0		
1880	RCS LINE #47	8	18,9	18,9	19,0	19,0	20,1	20,1	10,9	h	10,9	h	11,0	h	11,0	h	28,1	h	28,1	h	10,0	50,0		
1881	RCS LINE #47	8	18,9	18,9	19,0	19,0	20,1	20,1	10,9	h	10,9	h	11,0	h	11,0	h	28,1	h	28,1	h	10,0	50,0		

Controlled Distribution

REFERENCE : H-P-RP-AI-0040

DATE : 29/SEP/06

ISSUE : 06 Page : 225/405



NODE	LABEL	UFP													TEMPERATURE LIMIT			
			CASE A1	CASE A2	CASE A3	CASE C	CASE B1	CASE B2	CASE A1	CASE A2	CASE A3	CASE C	CASE B1	CASE B2	MIN	MAX	MIN	MAX
			Min	Min	Min	Min	Max	Max	Tmin - UFP	Tmin - UFP	Tmin - UFP	Tmin - UFP	Tmax +UFP	Tmax +UFP	OPER.	OPER.	N. OP.	N. OP.
1882	RCS LINE #47	8	18,9	18,9	19,0	19,0	20,1	20,1	10,9 h	10,9 h	11,0 h	11,0 h	28,1 h	28,1 h	10,0	50,0		
1883	RCS LINE #47	8	18,9	18,9	19,0	19,0	20,1	20,1	10,9 h	10,9 h	11,0 h	11,0 h	28,1 h	28,1 h	10,0	50,0		
1884	RCS LINE #47	8	18,9	18,9	19,0	19,0	20,1	20,1	10,9 h	10,9 h	11,0 h	11,0 h	28,1 h	28,1 h	10,0	50,0		
1885	RCS LINE #47	8	18,9	18,9	19,0	19,0	20,1	20,1	10,9 h	10,9 h	11,0 h	11,0 h	28,1 h	28,1 h	10,0	50,0		
1886	RCS LINE #47	8	27,0	26,4	26,8	29,6	31,7	30,2	19,0 h	18,4 h	18,8 h	21,6 h	39,7 h	38,2 h	10,0	50,0		
1887	RCS LINE #47	8	27,0	26,4	26,8	29,6	31,7	30,2	19,0 h	18,4 h	18,8 h	21,6 h	39,7 h	38,2 h	10,0	50,0		
1888	RCS LINE #47	8	33,9	32,2	33,2	32,0	37,2	35,5	25,9 h	24,2 h	25,2 h	24,0 h	45,2 h	43,5 h	10,0	50,0		
1889	RCS LINE #47	8	33,9	32,2	33,2	32,0	37,2	35,5	25,9 h	24,2 h	25,2 h	24,0 h	45,2 h	43,5 h	10,0	50,0		
1890	RCS LINE #47	8	33,9	32,2	33,2	32,0	37,2	35,5	25,9 h	24,2 h	25,2 h	24,0 h	45,2 h	43,5 h	10,0	50,0		
1891	RCS LINE #47	8	33,9	32,2	33,2	32,0	37,2	35,5	25,9 h	24,2 h	25,2 h	24,0 h	45,2 h	43,5 h	10,0	50,0		
1892	RCS LINE #47	8	33,9	32,2	33,2	32,0	37,2	35,5	25,9 h	24,2 h	25,2 h	24,0 h	45,2 h	43,5 h	10,0	50,0		
1893	RCS LINE #47	8	33,9	32,2	33,2	32,0	37,2	35,5	25,9 h	24,2 h	25,2 h	24,0 h	45,2 h	43,5 h	10,0	50,0		
1894	RCS LINE #47	8	32,7	32,9	32,9	36,4	34,7	32,8	24,7 h	24,9 h	24,9 h	28,4 h	42,7 h	40,8 h	10,0	50,0		
1895	RCS LINE #47	8	32,7	32,9	32,9	36,4	34,7	32,8	24,7 h	24,9 h	24,9 h	28,4 h	42,7 h	40,8 h	10,0	50,0		
1896	RCS LINE #47	8	32,7	32,9	32,9	36,4	34,6	32,7	24,7 h	24,9 h	24,9 h	28,4 h	42,6 h	40,7 h	10,0	50,0		
1897	RCS LINE #47	8	32,9	31,2	32,2	30,8	36,6	35,0	24,9 h	23,2 h	24,2 h	22,8 h	44,6 h	43,0 h	10,0	50,0		
1898	RCS LINE #47	8	32,9	31,2	32,2	30,8	36,6	35,0	24,9 h	23,2 h	24,2 h	22,8 h	44,6 h	43,0 h	10,0	50,0		
1899	RCS LINE #47	8	32,9	31,2	32,2	30,8	36,6	35,0	24,9 h	23,2 h	24,2 h	22,8 h	44,6 h	43,0 h	10,0	50,0		
1900	RCS LINE #47	8	32,9	31,2	32,2	30,8	36,6	35,0	24,9 h	23,2 h	24,2 h	22,8 h	44,6 h	43,0 h	10,0	50,0		
1901	RCS LINE #47	8	32,9	31,2	32,2	30,8	36,6	35,0	24,9 h	23,2 h	24,2 h	22,8 h	44,6 h	43,0 h	10,0	50,0		
1902	RCS LINE #47	8	32,9	31,2	32,2	30,8	36,6	35,0	24,9 h	23,2 h	24,2 h	22,8 h	44,6 h	43,0 h	10,0	50,0		
1903	RCS LINE #47	8	31,8	31,9	31,9	35,2	34,1	32,2	23,8 h	23,9 h	23,9 h	27,2 h	42,1 h	40,2 h	10,0	50,0		
1904	RCS LINE #47	8	31,8	31,9	31,9	35,2	34,1	32,2	23,8 h	23,9 h	23,9 h	27,2 h	42,1 h	40,2 h	10,0	50,0		
1905	RCS LINE #47	8	31,8	31,9	31,9	35,2	34,1	32,2	23,8 h	23,9 h	23,9 h	27,2 h	42,1 h	40,2 h	10,0	50,0		

Controlled Distribution

REFERENCE : H-P-RP-AI-0040

DATE : 29/SEP/06

ISSUE : 06 Page : 226/405



NODE	LABEL	UFP	CASE	CASE	CASE	CASE	CASE	CASE	CASE	CASE	CASE	CASE	CASE	CASE	TEMPERATURE LIMIT			
			A1	A2	A3	C	B1	B2	A1	A2	A3	C	B1	B2	MIN	MAX	MIN	MAX
			Min	Min	Min	Min	Max	Max	Tmin - UFP	Tmin - UFP	Tmin - UFP	Tmin - UFP	Tmax +UFP	Tmax +UFP	OPER.	OPER.	N. OP.	N. OP.
1906	RCS LINE #47	8	39,3	39,8	39,6	43,3	40,6	39,0	31,3 h	31,8 h	31,6 h	35,3 h	48,6 h	47,0 h	10,0	50,0		
1907	RCS LINE #47	8	41,1	42,4	41,8	45,9	41,4	39,7	33,1 h	34,4 h	33,8 h	37,9 h	49,4 h	47,7 h	10,0	50,0		
1908	RCS LINE #47	8	30,9	32,0	31,5	35,8	32,4	30,6	22,9 h	24,0 h	23,5 h	27,8 h	40,4 h	38,6 h	10,0	50,0		
1909	RCS LINE #47	8	37,9	39,2	38,6	45,5	38,7	37,0	29,9 h	31,2 h	30,6 h	37,5 h	46,7 h	45,0 h	10,0	50,0		
1910	RCS LINE #47	8	42,1	42,5	42,4	49,9	45,3	44,3	34,1 h	34,5 h	34,4 h	41,9 h	53,3 h	52,3 h	10,0	50,0		
1911	RCS LINE #47	8	24,3	25,0	27,2	25,7	27,6	26,6	16,3 h	17,0 h	19,2 h	17,7 h	35,6 h	34,6 h	10,0	50,0		
1912	RCS LINE #47	8	32,8	34,1	33,7	36,7	34,4	32,7	24,8 h	26,1 h	25,7 h	28,7 h	42,4 h	40,7 h	10,0	50,0		
1913	RCS LINE #47	8	31,9	33,0	32,6	36,0	33,5	31,8	23,9 h	25,0 h	24,6 h	28,0 h	41,5 h	39,8 h	10,0	50,0		
1914	RCS LINE #47	8	22,7	22,7	22,8	25,3	26,7	25,7	14,7 h	14,7 h	14,8 h	17,3 h	34,7 h	33,7 h	10,0	50,0		
1915	RCS LINE #47	8	26,7	27,2	27,0	30,2	29,3	27,9	18,7 h	19,2 h	19,0 h	22,2 h	37,3 h	35,9 h	10,0	50,0		
1916	RCS LINE #47	8	37,6	38,4	38,0	41,3	38,8	37,5	29,6 h	30,4 h	30,0 h	33,3 h	46,8 h	45,5 h	10,0	50,0		
1917	RCS LINE #47	8	26,3	25,6	26,1	28,6	31,1	29,7	18,3 h	17,6 h	18,1 h	20,6 h	39,1 h	37,7 h	10,0	50,0		
1918	RCS LINE #47	8	25,7	25,8	25,8	31,1	29,8	28,2	17,7 h	17,8 h	17,8 h	23,1 h	37,8 h	36,2 h	10,0	50,0		
1919	RCS LINE #47	8	21,1	22,0	21,6	30,5	25,8	24,2	13,1 h	14,0 h	13,6 h	22,5 h	33,8 h	32,2 h	10,0	50,0		
1920	RCS LINE #47	8	18,0	19,1	18,5	26,7	20,9	19,4	10,0 h	11,1 h	10,5 h	18,7 h	28,9 h	27,4 h	10,0	50,0		
1921	RCS LINE #47	8	21,6	22,4	21,9	25,7	22,6	21,9	13,6 h	14,4 h	13,9 h	17,7 h	30,6 h	29,9 h	10,0	50,0		
1951	RCS LINE #47	8	32,6	32,8	32,8	36,5	35,0	33,0	24,6 h	24,8 h	24,8 h	28,5 h	43,0 h	41,0 h	10,0	50,0		
1952	RCS LINE #47	8	32,7	32,9	32,9	36,5	35,1	33,1	24,7 h	24,9 h	24,9 h	28,5 h	43,1 h	41,1 h	10,0	50,0		
1922	RCS LINE #48	8	23,7	23,3	23,9	26,8	25,4	25,4	15,7 h	15,3 h	15,9 h	18,8 h	33,4 h	33,4 h	10,0	50,0		
1923	RCS LINE #48	8	23,7	23,3	23,9	26,8	25,4	25,4	15,7 h	15,3 h	15,9 h	18,8 h	33,4 h	33,4 h	10,0	50,0		
1924	RCS LINE #48	8	23,7	23,3	23,9	26,8	25,4	25,4	15,7 h	15,3 h	15,9 h	18,8 h	33,4 h	33,4 h	10,0	50,0		
1925	RCS LINE #48	8	23,7	23,3	23,9	26,8	25,4	25,4	15,7 h	15,3 h	15,9 h	18,8 h	33,4 h	33,4 h	10,0	50,0		
1926	RCS LINE #48	8	23,7	23,3	23,9	26,8	25,4	25,4	15,7 h	15,3 h	15,9 h	18,8 h	33,4 h	33,4 h	10,0	50,0		
1927	RCS LINE #48	8	21,6	20,7	21,3	21,6	24,2	24,2	13,6 h	12,7 h	13,3 h	13,6 h	32,2 h	32,2 h	10,0	50,0		

Controlled Distribution

REFERENCE : H-P-RP-AI-0040

DATE : 29/SEP/06

ISSUE : 06 Page : 227/405



NODE	LABEL	UFP													TEMPERATURE LIMIT			
			CASE A1	CASE A2	CASE A3	CASE C	CASE B1	CASE B2	CASE A1	CASE A2	CASE A3	CASE C	CASE B1	CASE B2	MIN	MAX	MIN	MAX
			Min	Min	Min	Min	Max	Max	Tmin - UFP	Tmin - UFP	Tmin - UFP	Tmin - UFP	Tmax +UFP	Tmax +UFP	OPER.	OPER.	N. OP.	N. OP.
1928	RCS LINE #48	8	21,6	20,7	21,3	21,6	24,2	24,2	13,6 h	12,7 h	13,3 h	13,6 h	32,2 h	32,2 h	10,0	50,0		
1929	RCS LINE #48	8	21,6	20,7	21,3	21,6	24,2	24,2	13,6 h	12,7 h	13,3 h	13,6 h	32,2 h	32,2 h	10,0	50,0		
1930	RCS LINE #48	8	22,9	20,9	22,3	22,1	28,5	28,5	14,9 h	12,9 h	14,3 h	14,1 h	36,5 h	36,5 h	10,0	50,0		
1931	RCS LINE #48	8	24,3	24,2	24,5	29,4	28,9	28,9	16,3 h	16,2 h	16,5 h	21,4 h	36,9 h	36,9 h	10,0	50,0		
1932	RCS LINE #48	8	24,0	23,7	24,2	27,3	25,0	25,0	16,0 h	15,7 h	16,2 h	19,3 h	33,0 h	33,0 h	10,0	50,0		
1933	RCS LINE #48	8	24,0	23,7	24,2	27,3	25,0	25,0	16,0 h	15,7 h	16,2 h	19,3 h	33,0 h	33,0 h	10,0	50,0		
1934	RCS LINE #48	8	21,4	18,8	20,5	18,4	27,4	27,4	13,4 h	10,8 h	12,5 h	10,4 h	35,4 h	35,4 h	10,0	50,0		
1935	RCS LINE #48	8	20,5	18,7	20,1	19,3	23,6	23,6	12,5 h	10,7 h	12,1 h	11,3 h	31,6 h	31,6 h	10,0	50,0		
1936	RCS LINE #48	8	20,9	19,3	20,5	19,9	23,8	23,8	12,9 h	11,3 h	12,5 h	11,9 h	31,8 h	31,8 h	10,0	50,0		
1937	RCS LINE #48	8	21,2	19,8	20,9	20,6	24,1	24,1	13,2 h	11,8 h	12,9 h	12,6 h	32,1 h	32,1 h	10,0	50,0		
1938	RCS LINE #48	8	21,7	20,4	21,4	21,7	24,8	24,8	13,7 h	12,4 h	13,4 h	13,7 h	32,8 h	32,8 h	10,0	50,0		
1939	RCS LINE #48	8	20,7	20,1	20,5	21,1	22,9	22,9	12,7 h	12,1 h	12,5 h	13,1 h	30,9 h	30,9 h	10,0	50,0		
1940	RCS LINE #48	8	20,6	20,9	20,7	22,6	22,2	22,2	12,6 h	12,9 h	12,7 h	14,6 h	30,2 h	30,2 h	10,0	50,0		
1941	RCS LINE #48	8	19,0	19,0	19,0	19,9	20,1	20,1	11,0 h	11,0 h	11,0 h	11,9 h	28,1 h	28,1 h	10,0	50,0		
1942	RCS LINE #48	8	18,5	18,4	18,5	19,3	19,6	19,6	10,5 h	10,4 h	10,5 h	11,3 h	27,6 h	27,6 h	10,0	50,0		
1943	RCS LINE #48	8	18,9	19,6	21,6	23,9	19,1	19,1	10,9 h	11,6 h	13,6 h	15,9 h	27,1 h	27,1 h	10,0	50,0		
1944	RCS LINE #48	8	21,3	21,5	21,3	23,2	22,8	22,8	13,3 h	13,5 h	13,3 h	15,2 h	30,8 h	30,8 h	10,0	50,0		
1945	RCS LINE #48	8	30,1	30,6	30,2	32,6	31,5	31,5	22,1 h	22,6 h	22,2 h	24,6 h	39,5 h	39,5 h	10,0	50,0		
1946	RCS LINE #48	8	40,3	39,9	40,0	40,3	44,6	44,6	32,3 h	31,9 h	32,0 h	32,3 h	52,6 h	52,6 h	10,0	50,0		
1947	RCS LINE #48	8	19,9	19,7	20,0	26,9	22,0	22,2	11,9 h	11,7 h	12,0 h	18,9 h	30,0 h	30,2 h	10,0	50,0		
8001	SA EXT -X/ext part	8	107,8	107,8	107,8	108,7	117,9	117,9	99,8	99,8	99,8	100,7	125,9	125,9				
8002	SA EXT -X/ext part	8	109,0	109,0	109,0	109,9	118,8	118,8	101,0	101,0	101,0	101,9	126,8	126,8				
8003	SA EXT -X/ext part	8	107,5	107,5	107,5	108,6	117,7	117,7	99,5	99,5	99,5	100,6	125,7	125,7				
8004	SA EXT -X/ext part	7,5	107,0	107,0	107,0	108,1	117,2	117,2	99,5	99,5	99,5	100,6	124,7	124,7				

Controlled Distribution

REFERENCE : H-P-RP-AI-0040

DATE : 29/SEP/06

ISSUE : 06

Page : 228/405



NODE	LABEL	UFP	CASE A1	CASE A2	CASE A3	CASE C	CASE B1	CASE B2	CASE A1	CASE A2	CASE A3	CASE C	CASE B1	CASE B2	TEMPERATURE LIMIT															
															Min	Min	Min	Min	Max	Max	Tmin - UFP	Tmin - UFP	Tmin - UFP	Tmin - UFP	Tmax +UFP	Tmax +UFP	MIN	MAX	MIN	MAX
															OPER.	OPER.	N. OP.	N. OP.	OPER.	OPER.	N. OP.	N. OP.								
8005	SA EXT -X/ext part	7,5	107,4	107,4	107,4	108,5	117,6	117,5	99,9	99,9	99,9	101,0	125,1	125,0																
8006	SA EXT -X/ext part	7,5	105,9	105,9	105,9	107,9	117,6	117,6	98,4	98,4	98,4	100,4	125,1	125,1																
8007	SA EXT -X/ext part	8,4	107,1	107,1	107,1	108,2	117,2	117,2	98,7	98,7	98,7	99,8	125,6	125,6																
8008	SA EXT -X/ext part	8,4	107,4	107,4	107,4	108,6	117,5	117,5	99,0	99,0	99,0	100,2	125,9	125,9																
8009	SA EXT -X/ext part	8,4	107,5	107,5	107,5	108,6	117,6	117,6	99,1	99,1	99,1	100,2	126,0	126,0																
8010	SA EXT -X/ext part	8,1	105,6	105,6	105,6	107,0	115,9	115,9	97,5	97,5	97,5	98,9	124,0	124,0																
8011	SA EXT -X/ext part	8,1	107,8	107,8	107,8	108,8	117,8	117,8	99,7	99,7	99,7	100,7	125,9	125,9																
8012	SA EXT -X/ext part	8,1	108,1	108,0	108,0	108,8	117,5	117,5	100,0	99,9	99,9	100,7	125,6	125,6																
8051	SA EXT +X/ext part	8	107,4	107,4	107,4	108,3	117,4	117,4	99,4	99,4	99,4	100,3	125,4	125,4																
8052	SA EXT +X/ext part	8	108,7	108,7	108,7	109,5	118,4	118,4	100,7	100,7	100,7	101,5	126,4	126,4																
8053	SA EXT +X/ext part	8	107,3	107,2	107,3	108,3	117,4	117,4	99,3	99,2	99,3	100,3	125,4	125,4																
8054	SA EXT +X/ext part	7,6	106,6	106,6	106,6	107,7	116,7	116,7	99,0	99,0	99,0	100,1	124,3	124,3																
8055	SA EXT +X/ext part	7,6	107,1	107,1	107,1	108,2	117,2	117,2	99,5	99,5	99,5	100,6	124,8	124,8																
8056	SA EXT +X/ext part	7,6	105,6	105,6	105,6	107,6	117,2	117,2	98,0	98,0	98,0	100,0	124,8	124,8																
8057	SA EXT +X/ext part	8,4	106,7	106,7	106,7	107,8	116,8	116,8	98,3	98,3	98,3	99,4	125,2	125,2																
8058	SA EXT +X/ext part	8,4	107,1	107,1	107,1	108,3	117,2	117,2	98,7	98,7	98,7	99,9	125,6	125,6																
8059	SA EXT +X/ext part	8,4	107,2	107,2	107,2	108,3	117,3	117,3	98,8	98,8	98,8	99,9	125,7	125,7																
8060	SA EXT +X/ext part	8,1	105,2	105,2	105,2	106,6	115,5	115,5	97,1	97,1	97,1	98,5	123,6	123,6																
8061	SA EXT +X/ext part	8,1	107,5	107,5	107,5	108,5	117,5	117,5	99,4	99,4	99,4	100,4	125,6	125,6																
8062	SA EXT +X/ext part	8,1	107,8	107,8	107,8	108,6	117,2	117,2	99,7	99,7	99,7	100,5	125,3	125,3																
8171	SA EXT +X/int part	8	111,2	111,2	111,2	111,2	119,6	119,6	103,2	103,2	103,2	103,2	127,6	127,6																
8172	SA EXT +X/int part	8	107,0	107,0	107,0	107,7	116,8	116,8	99,0	99,0	99,0	99,7	124,8	124,8																
8173	SA EXT +X/int part	8	108,0	108,0	108,0	109,3	118,8	118,8	100,0	100,0	100,0	101,3	126,8	126,8																
8174	SA EXT +X/int part	7,6	106,0	106,0	106,0	108,2	118,7	118,7	98,4	98,4	98,4	100,6	126,3	126,3																

Controlled Distribution

REFERENCE : H-P-RP-AI-0040

DATE : 29/SEP/06

ISSUE : 06

Page : 229/405



NODE	LABEL	UFP	CASE A1	CASE A2	CASE A3	CASE C	CASE B1	CASE B2	CASE A1	CASE A2	CASE A3	CASE C	CASE B1	CASE B2	TEMPERATURE LIMIT															
															Min	Min	Min	Min	Max	Max	Tmin - UFP	Tmin - UFP	Tmin - UFP	Tmin - UFP	Tmax +UFP	Tmax +UFP	MIN	MAX	MIN	MAX
															OPER.	OPER.	N. OP.	N. OP.												
8175	SA EXT +X/int part	7,6	106,3	106,3	106,3	108,6	118,9	118,9	98,7	98,7	98,7	101,0	126,5	126,5																
8176	SA EXT +X/int part	7,6	107,0	107,0	107,0	109,5	119,0	119,0	99,4	99,4	99,4	101,9	126,6	126,6																
8177	SA EXT +X/int part	8,4	107,0	107,0	107,0	108,1	119,0	119,0	98,6	98,6	98,6	99,7	127,4	127,4																
8178	SA EXT +X/int part	8,4	107,4	107,4	107,4	109,0	118,5	118,5	99,0	99,0	99,0	100,6	126,9	126,9																
8179	SA EXT +X/int part	8,4	108,5	108,5	108,5	109,5	118,0	118,1	100,1	100,1	100,1	101,1	126,4	126,5																
8180	SA EXT +X/int part	8,1	112,0	112,0	112,0	111,5	120,2	120,2	103,9	103,9	103,9	103,4	128,3	128,3																
8181	SA EXT +X/int part	8,1	110,4	110,4	110,4	110,2	117,8	117,8	102,3	102,3	102,3	102,1	125,9	125,9																
8182	SA EXT +X/int part	8,1	110,4	110,4	110,4	110,3	119,9	119,9	102,3	102,3	102,3	102,2	128,0	128,0																
8301	Central S. A. -X	7,9	116,4	116,3	116,3	117,7	126,9	126,9	108,5	108,4	108,4	109,8	134,8	134,8																
8302	Central S. A. -X	7,9	115,4	115,4	115,4	116,5	125,7	125,7	107,5	107,5	107,5	108,6	133,6	133,6																
8303	Central S. A. -X	7,9	115,1	115,1	115,1	116,2	125,4	125,4	107,2	107,2	107,2	108,3	133,3	133,3																
8304	Central S. A. -X	8	115,0	115,0	115,0	116,1	125,3	125,3	107,0	107,0	107,0	108,1	133,3	133,3																
8305	Central S. A. -X	8	115,0	115,0	115,0	116,1	125,3	125,3	107,0	107,0	107,0	108,1	133,3	133,3																
8306	Central S. A. -X	8	115,1	115,1	115,1	116,2	125,4	125,4	107,1	107,1	107,1	108,2	133,4	133,4																
8307	Central S. A. -X	8,1	115,1	115,0	115,0	116,2	125,4	125,4	107,0	106,9	106,9	108,1	133,5	133,5																
8308	Central S. A. -X	8,1	115,1	115,1	115,1	116,3	125,6	125,6	107,0	107,0	107,0	108,2	133,7	133,7																
8309	Central S. A. -X	8,1	114,8	114,8	114,8	116,1	125,7	125,7	106,7	106,7	106,7	108,0	133,8	133,8																
8310	Central S. A. -X	7,9	115,1	115,0	115,1	116,2	125,4	125,4	107,2	107,1	107,2	108,3	133,3	133,3																
8311	Central S. A. -X	7,9	115,1	115,1	115,1	116,2	125,4	125,4	107,2	107,2	107,2	108,3	133,3	133,3																
8312	Central S. A. -X	7,9	115,2	115,2	115,2	116,3	125,5	125,5	107,3	107,3	107,3	108,4	133,4	133,4																
8351	Central S. A. +X	7,9	116,1	116,1	116,1	117,4	126,7	126,7	108,2	108,2	108,2	109,5	134,6	134,6																
8352	Central S. A. +X	7,9	115,3	115,2	115,3	116,3	125,5	125,5	107,4	107,3	107,4	108,4	133,4	133,4																
8353	Central S. A. +X	7,9	114,9	114,9	114,9	116,0	125,2	125,2	107,0	107,0	107,0	108,1	133,1	133,1																
8354	Central S. A. +X	8	114,8	114,8	114,8	115,9	125,1	125,1	106,8	106,8	106,8	107,9	133,1	133,1																

Controlled Distribution



REFERENCE : H-P-RP-AI-0040

DATE : 29/SEP/06

ISSUE : 06

Page : 230/405

NODE	LABEL	UFP	CASE A1	CASE A2	CASE A3	CASE C	CASE B1	CASE B2	CASE A1	CASE A2	CASE A3	CASE C	CASE B1	CASE B2	TEMPERATURE LIMIT															
															Min	Min	Min	Min	Max	Max	Tmin - UFP	Tmin - UFP	Tmin - UFP	Tmin - UFP	Tmax +UFP	Tmax +UFP	MIN	MAX	MIN	MAX
															OPER.	OPER.	N. OP.	N. OP.	OPER.	OPER.	N. OP.	N. OP.								
8355	Central S. A. +X	8	114,9	114,8	114,9	115,9	125,2	125,2	106,9	106,8	106,9	107,9	133,2	133,2																
8356	Central S. A. +X	8	114,9	114,9	114,9	116,0	125,2	125,2	106,9	106,9	106,9	108,0	133,2	133,2																
8357	Central S. A. +X	8,1	114,9	114,8	114,9	116,0	125,2	125,2	106,8	106,7	106,8	107,9	133,3	133,3																
8358	Central S. A. +X	8,1	115,0	114,9	115,0	116,1	125,4	125,4	106,9	106,8	106,9	108,0	133,5	133,5																
8359	Central S. A. +X	8,1	114,6	114,6	114,6	115,9	125,5	125,5	106,5	106,5	106,5	107,8	133,6	133,6																
8360	Central S. A. +X	7,9	114,9	114,9	114,9	116,0	125,2	125,2	107,0	107,0	107,0	108,1	133,1	133,1																
8361	Central S. A. +X	7,9	114,9	114,9	114,9	116,0	125,2	125,2	107,0	107,0	107,0	108,1	133,1	133,1																
8362	Central S. A. +X	7,9	115,1	115,0	115,1	116,2	125,4	125,4	107,2	107,1	107,2	108,3	133,3	133,3																

Note :

(1) The temperature (including uncertainty) reached by FOG (ICU) in Cold case A3 is 0.6 °C vs a minimum operative limit of 0.°C. In this case the temperature has been raised above 0°C switching on at 100% the 4K CRU's heaters mounted on the same shear panel.

In Hot cases B1 and B2, the maximum temperatures reached by the HP vertical nodes 811-826 and 861-876 are higher respect to the previous analysis results. The increase of the temperature is mainly due to the increase of the Heat pipes heater thresholds in Hot cases (3°C higher), in order to have only one set of heater settings, all along the satellite lifetime and avoid different settings between BOL and EOL conditions.

Since the heaters are enabled also in hot cases, the temperatures of SCC nodes (unit and HP network) are presented without uncertainty.

Controlled Distribution



REFERENCE : H-P-RP-AI-0040

DATE : 29/SEP/06

ISSUE : 06

Page : 231/405

8.5.4.2 Change of attitude transient case results

Transient analysis cases were run to assess the thermal behaviour of the SVM when subjected to attitude change (sun from 0 deg to +10 deg on -X side). Purpose of this paragraph is to report the temperature level reach from the units during the attitude change in terms of minimum and maximum temperature. In Table 8.5.4.2-1 the temperatures are reported without uncertainty. In AD[25] the temperature plots of the main units during the change of attitude transient cases P1 and Q2 are shown, with change of attitude occurring at Time =86400s. The complete temperature data are reported in AD[25].

NODE	LABEL	UFP	Case P SCC1 On		Case P SCC2 On		Case Q SCC1 On		Case Q SCC2 On	
			Min [°C]	Max [°C]	Min [°C]	Max [°C]	Min [°C]	Max [°C]	Min [°C]	Max [°C]
13	DPU1	8.1	11.7	11.9	11.8	12.0	15.7	15.9	15.7	15.9
14	DPU2	7.6	-3.8	-3.6	-3.7	-3.5	0.3	0.5	0.4	0.5
101	DCCU	8.0	8.9	9.2	9.0	9.2	13.1	13.3	13.1	13.3
102	REBA2	8.5	-2.6	-2.4	-2.5	-2.3	1.6	1.8	1.6	1.8
103	REBA1	7.8	7.6	7.8	7.7	7.9	11.3	11.5	11.3	11.5
104	FOG (GEU)	8.3	24.5	24.8	24.7	24.9	28.6	28.8	28.7	28.8
105	FOG (ICU)	8.0	11.8	12.0	11.9	12.1	16.2	16.4	16.2	16.4
131	DCCU BASEPLATE		5.7	6.0	5.9	6.0	9.8	10.0	9.9	10.0
132	DCCU BASEPLATE		10.3	10.6	10.5	10.7	14.9	15.2	14.9	15.2
133	DCCU BASEPLATE		13.6	13.9	13.8	14.0	18.2	18.5	18.3	18.5
134	DCCU BASEPLATE		11.8	12.1	11.9	12.2	16.5	16.8	16.6	16.8
135	DCCU BASEPLATE		13.3	13.6	13.4	13.7	18.1	18.4	18.2	18.4
136	DCCU BASEPLATE		14.4	14.7	14.5	14.8	19.2	19.5	19.2	19.5
202	4 CAU	8.1	-2.6	-2.4	-2.5	-2.3	0.1	0.3	0.1	0.3
203	4K CRU EX 4K PRE-REG	8.7	26.2	26.4	26.3	26.5	30.1	30.3	30.1	30.3
204	CEU	9.3	27.3	27.5	27.4	27.6	30.1	30.3	30.1	30.3
205	REU	9.2	21.8	22.1	22.0	22.1	24.7	24.9	24.7	24.9
211	CCU COMP1	11.0	44.7	44.9	44.8	45.0	47.3	47.5	47.4	47.5
212	CCU COMP2	10.5	39.3	39.5	39.4	39.6	42.0	42.2	42.0	42.2
213	CCU FLANGE1	10.2	32.4	32.6	32.5	32.6	35.0	35.2	35.1	35.2
214	CCU FLANGE2	10.1	30.6	30.8	30.7	30.8	33.2	33.4	33.3	33.4
215	CCU CRADLE	10.1	30.6	30.8	30.7	30.9	33.3	33.5	33.3	33.5
216	CCU SUPPORT	9.7	26.1	26.3	26.2	26.4	28.8	29.0	28.8	29.0
217	CCU BRACKET -X	9.4	22.8	23.0	22.9	23.1	25.6	25.8	25.6	25.8
218	CCU BRACKET +X	9.2	19.6	19.8	19.7	19.8	22.3	22.5	22.3	22.4
219	CCU BRACKET -X I/F	9.1	15.3	15.5	15.3	15.5	17.9	18.1	17.9	18.1
220	CCU BRACKET +X I/F	8.6	8.6	8.8	8.7	8.8	11.1	11.3	11.1	11.3
221	CCU STRAP -Z I/F	9.9	23.1	23.3	23.2	23.4	25.8	26.0	25.9	26.0
222	CCU STRAP +Z I/F	9.8	21.1	21.3	21.2	21.3	23.7	23.9	23.7	23.9
223	CCU SHIELD	9.0	22.8	23.0	22.9	23.1	25.9	26.1	25.9	26.1
224	CCU SHIELD	8.7	21.7	22.0	21.8	22.1	25.4	25.7	25.4	25.7

Controlled Distribution



REFERENCE : H-P-RP-AI-0040

DATE : 29/SEP/06

ISSUE : 06

Page : 232/405

NODE	LABEL	UFP	Case P SCC1 On		Case P SCC2 On		Case Q SCC1 On		Case Q SCC2 On	
			Min [°C]	Max [°C]	Min [°C]	Max [°C]	Min [°C]	Max [°C]	Min [°C]	Max [°C]
225	CCU SHIELD	8.9	19.5	19.7	19.6	19.7	22.4	22.7	22.4	22.6
226	CCU SHIELD	9.1	19.6	19.8	19.7	19.8	22.4	22.6	22.4	22.6
227	CCU SHIELD	8.8	21.5	21.7	21.6	21.8	24.7	25.0	24.7	25.0
228	CCU SHIELD	9.2	23.0	23.2	23.1	23.3	25.9	26.1	25.9	26.1
229	CCU SHIELD	8.9	21.2	21.5	21.3	21.6	24.7	24.9	24.7	24.9
230	CCU SHIELD	9.0	18.2	18.4	18.3	18.5	21.1	21.4	21.1	21.3
231	CCU SHIELD	9.3	21.4	21.6	21.5	21.6	24.1	24.3	24.1	24.3
232	CCU SHIELD	8.9	18.8	19.1	18.9	19.2	21.9	22.1	21.9	22.1
311	SCC1 - Outer shell1	9.9	-9.9	12.7	-11.5	-10.5	-6.0	21.6	-8.8	-8.5
312	SCC1 - Outer shell2	9.9	-9.9	12.8	-11.5	-10.5	-6.0	21.8	-8.8	-8.5
313	SCC1 - Outer shell3	9.9	-9.9	12.8	-11.5	-10.5	-6.0	21.7	-8.8	-8.5
314	SCC1 - Outer shell4	9.9	-9.9	12.8	-11.5	-10.5	-6.0	21.7	-8.8	-8.5
315	SCC1 - Outer shell5	9.9	-9.9	12.8	-11.5	-10.5	-6.0	21.7	-8.8	-8.5
316	SCC1 - Outer shell6	9.9	-9.9	12.8	-11.5	-10.4	-6.0	21.7	-8.8	-8.5
331	SCC1 - Inner bed1	0.0	-8.0	185.3	-5.2	42.0	0.4	234.0	-4.0	35.9
332	SCC1 - Inner bed2	0.0	-8.0	185.3	-10.1	-3.5	0.4	234.1	-8.3	-5.0
333	SCC1 - Inner bed3	0.0	-8.0	185.2	-9.8	-1.2	0.5	233.9	-8.2	-4.2
334	SCC1 - Inner bed4	0.0	-7.9	185.2	-9.9	-1.5	0.4	234.4	-8.1	-3.4
335	SCC1 - Inner bed5	0.0	-8.0	185.1	4.5	109.6	0.4	234.1	-7.6	1.7
336	SCC1 - Inner bed6	0.0	-8.0	185.1	10.9	170.1	0.4	233.9	-1.0	64.2
401	SCE1	9.3	-9.2	-8.3	-9.2	-8.3	-4.1	-3.4	-9.2	-8.9
402	SCE2	9.3	-11.9	-11.0	-12.0	-10.9	-9.0	-8.3	-4.8	-4.5
511	SCC2 - Outer shell1	9.1	-12.8	-12.4	-8.4	14.6	-10.7	-10.4	-4.1	23.5
512	SCC2 - Outer shell2	9.1	-12.8	-12.4	-8.2	14.4	-10.7	-10.4	-4.1	23.5
513	SCC2 - Outer shell3	9.1	-12.8	-12.4	-8.3	14.8	-10.7	-10.4	-4.1	23.5
514	SCC2 - Outer shell4	9.1	-12.8	-12.4	-8.4	14.6	-10.7	-10.4	-4.1	23.5
515	SCC2 - Outer shell5	9.1	-12.8	-12.4	-8.1	14.6	-10.7	-10.4	-4.1	23.6
516	SCC2 - Outer shell6	9.1	-12.8	-12.4	-8.3	14.8	-10.7	-10.4	-4.1	23.5
519	BEU LATERAL -Y	9.2	15.3	15.8	15.5	16.1	20.4	21.1	20.5	21.1
520	BEU CENTRAL	9.3	12.6	13.1	12.8	13.3	17.6	18.3	17.7	18.3
521	BEU LATERAL +Y	9.2	15.8	16.3	16.0	16.6	21.0	21.7	21.1	21.7
522	PAU	8.6	13.1	13.6	13.4	13.9	18.1	18.7	18.1	18.7
525	DAE POWER BOX	8.1	27.6	28.0	27.8	28.2	33.1	33.5	33.1	33.5
531	SCC2 - Inner bed1	0.0	-12.6	-12.5	-6.0	187.5	-10.6	-10.4	2.5	236.1
532	SCC2 - Inner bed2	0.0	-12.6	-12.5	-5.8	187.4	-10.6	-10.4	2.4	236.2
533	SCC2 - Inner bed3	0.0	-12.6	-12.5	-5.7	187.5	-10.6	-10.4	2.4	236.1
534	SCC2 - Inner bed4	0.0	-12.6	-12.5	-6.0	187.2	-10.6	-10.4	2.4	236.6
535	SCC2 - Inner bed5	0.0	-12.6	-12.5	-5.8	187.3	-10.6	-10.4	2.4	236.2
536	SCC2 - Inner bed6	0.0	-12.6	-12.5	-5.7	187.5	-10.6	-10.4	2.4	236.1
560	BEU CENTRAL - Baseplate	9.2	11.8	12.2	12.0	12.5	16.8	17.4	16.9	17.5
561	BEU	9.4	-3.9	-3.5	-3.7	-3.3	0.4	1.0	0.5	1.0

Controlled Distribution



REFERENCE : H-P-RP-AI-0040

DATE : 29/SEP/06

ISSUE : 06

Page : 233/405

NODE	LABEL	UFP	Case P SCC1 On		Case P SCC2 On		Case Q SCC1 On		Case Q SCC2 On	
			Min [°C]	Max [°C]	Min [°C]	Max [°C]	Min [°C]	Max [°C]	Min [°C]	Max [°C]
562	BEU	9.3	3.3	3.7	3.5	3.9	7.8	8.4	7.9	8.4
563	BEU	9.3	3.3	3.7	3.4	3.9	7.8	8.4	7.9	8.4
564	BEU	9.4	-3.9	-3.5	-3.7	-3.3	0.4	0.9	0.4	0.9
566	BEU	9.4	-4.0	-3.6	-3.9	-3.4	0.3	0.8	0.3	0.8
567	BEU	9.3	2.3	2.7	2.5	3.0	6.8	7.4	6.9	7.4
568	BEU	9.3	2.3	2.7	2.5	2.9	6.8	7.4	6.9	7.4
569	BEU	9.4	-4.0	-3.6	-3.9	-3.4	0.2	0.8	0.3	0.8
571	BEU	9.4	-5.0	-4.6	-4.9	-4.4	-0.8	-0.3	-0.7	-0.2
572	BEU	9.3	-1.2	-0.8	-1.0	-0.6	3.1	3.7	3.2	3.7
573	BEU	9.3	-1.2	-0.8	-1.0	-0.6	3.1	3.7	3.2	3.7
574	BEU	9.4	-5.0	-4.7	-4.9	-4.4	-0.9	-0.3	-0.8	-0.3
578	BEU BASEPLATE	9.3	5.1	5.5	5.3	5.8	9.8	10.4	9.9	10.4
581	PAU RADIATOR	8.4	5.8	6.2	6.0	6.5	10.5	11.0	10.5	11.0
582	PAU RADIATOR	8.4	5.2	5.7	5.5	5.9	9.9	10.4	9.9	10.4
583	PAU RADIATOR	8.4	4.2	4.7	4.5	4.9	8.8	9.3	8.8	9.3
584	PAU RADIATOR	8.3	1.3	1.7	1.5	2.0	5.8	6.3	5.8	6.3
585	PAU RADIATOR	8.3	0.5	0.9	0.7	1.1	4.8	5.3	4.9	5.4
586	PAU RADIATOR	8.3	-0.4	0.0	-0.2	0.2	3.9	4.4	3.9	4.4
587	PAU RADIATOR	8.2	-0.8	-0.4	-0.6	-0.2	3.5	4.0	3.5	4.0
588	PAU RADIATOR	8.2	-1.8	-1.4	-1.5	-1.1	2.5	3.0	2.5	3.0
589	PAU RADIATOR	8.2	-2.5	-2.1	-2.3	-1.9	1.7	2.2	1.7	2.2
590	PAU RADIATOR	8.3	1.0	1.5	1.3	1.7	5.5	6.0	5.5	6.0
591	PAU RADIATOR	8.1	0.6	1.0	0.8	1.3	5.0	5.5	5.0	5.5
592	PAU RADIATOR	8.2	-1.6	-1.2	-1.4	-1.0	2.7	3.2	2.7	3.2
593	PAU RADIATOR	8.1	-2.6	-2.2	-2.4	-1.9	1.6	2.1	1.7	2.1
594	PAU RADIATOR	8.1	-3.1	-2.7	-2.9	-2.5	1.1	1.6	1.1	1.6
595	PAU RADIATOR	8.1	-4.2	-3.8	-4.0	-3.5	0.0	0.4	0.0	0.4
596	PAU BASEPLATE	0.0	12.4	12.8	12.6	13.1	17.4	18.0	17.5	18.0
597	PAU BASEPLATE	0.0	10.5	11.0	10.8	11.3	15.5	16.1	15.5	16.1
598	PAU BASEPLATE	0.0	11.2	11.7	11.5	12.0	16.3	16.9	16.3	16.9
599	PAU BASEPLATE	0.0	1.3	1.8	1.6	2.0	5.8	6.3	5.8	6.3
601	XPND_1	8.3	8.6	14.2	8.7	14.2	11.5	16.9	11.5	16.9
602	XPND_2	7.9	4.5	6.8	4.5	6.8	7.7	10.0	7.5	9.8
603	TWTA_1 BODY	8.8	-10.1	30.3	-10.0	30.4	-7.3	32.4	-7.3	32.4
604	TWTA_2 BODY	7.7	-13.5	-7.7	-13.4	-7.6	-10.4	-4.7	-10.4	-4.7
605	RFDN	7.9	-2.7	8.1	-2.6	8.2	0.5	11.1	0.5	11.1
606	EPC1	8.3	-2.1	12.8	-2.1	12.8	0.8	15.5	0.9	15.6
607	EPC2	7.7	-5.0	-2.3	-5.0	-2.3	-1.7	0.9	-2.1	0.5
608	TWTA_1 HEAD	8.8	-9.3	46.1	-9.2	46.2	-6.6	48.1	-6.5	48.1
609	TWTA_2 HEAD	7.7	-13.3	-7.6	-13.2	-7.5	-10.1	-4.5	-10.1	-4.6
701	CDMU	8.1	15.7	16.0	15.8	16.1	19.5	19.8	19.5	19.8

Controlled Distribution



REFERENCE : H-P-RP-AI-0040

DATE : 29/SEP/06

ISSUE : 06

Page : 234/405

NODE	LABEL	UFP	Case P SCC1 On		Case P SCC2 On		Case Q SCC1 On		Case Q SCC2 On	
			Min [°C]	Max [°C]	Min [°C]	Max [°C]	Min [°C]	Max [°C]	Min [°C]	Max [°C]
702	ACC	8.0	8.3	8.6	8.4	8.7	11.8	12.1	11.8	12.1
703	BATT	8.0	12.7	13.2	12.7	13.2	18.9	19.4	18.9	19.3
704	PCDU	8.7	28.8	29.3	28.9	29.4	33.1	33.5	33.1	33.5
705	CRS1	8.6	47.9	48.6	48.0	48.6	47.9	48.5	47.9	48.6
706	CRS2	8.7	47.9	48.6	47.9	48.5	47.9	48.6	47.9	48.6
707	CRS3 (-Y-Z)	8.7	34.9	35.5	35.0	35.5	34.9	35.6	34.9	35.6
801	HP1 Hor. SCC1	9.3	-11.4	-9.5	-11.2	-9.9	-8.6	-6.5	-8.8	-7.9
802	HP2 Hor. SCC1	9.3	-10.8	-9.2	-10.7	-9.4	-7.6	-6.0	-9.2	-8.4
803	HP3 Hor. SCC1	9.3	-11.8	-10.3	-11.7	-10.5	-8.1	-6.4	-9.9	-9.2
804	HP4 Hor. SCC1	9.3	-11.5	-9.9	-11.5	-9.9	-8.2	-6.5	-9.9	-9.2
805	HP5 Hor. SCC1	9.3	-12.4	-10.3	-12.2	-10.7	-10.0	-8.0	-10.0	-9.0
806	HP6 Hor. SCC1	9.3	-12.7	-11.0	-12.7	-11.0	-9.8	-8.2	-8.6	-7.8
807	HP7 Hor. SCC1	9.3	-12.3	-10.7	-12.4	-10.7	-9.8	-8.1	-8.4	-7.7
808	HP7 Hor. SCC1	9.3	-12.1	-10.4	-11.9	-10.6	-9.6	-7.9	-8.2	-7.4
811	HP11 Ver. SCC1	9.7	-10.3	-5.9	-11.5	-10.5	-6.6	-1.7	-8.8	-8.5
812	HP12 Ver. SCC1	9.7	-10.0	-4.6	-11.5	-10.5	-6.1	-0.1	-8.8	-8.5
813	HP13 Ver. SCC1	9.7	-10.0	-4.6	-11.5	-10.5	-6.1	-0.1	-8.8	-8.5
814	HP14 Ver. SCC1	9.7	-10.0	-4.6	-11.5	-10.5	-6.1	-0.1	-8.8	-8.5
815	HP15 Ver. SCC1	9.7	-10.0	-4.6	-11.5	-10.5	-6.1	-0.1	-8.8	-8.5
816	HP16 Ver. SCC1	9.7	-10.0	-4.6	-11.5	-10.5	-6.1	-0.1	-8.8	-8.5
817	HP17 Ver. SCC1	9.7	-10.0	-4.6	-11.5	-10.5	-6.1	-0.1	-8.8	-8.5
818	HP18 Ver. SCC1	9.7	-10.0	-4.6	-11.5	-10.5	-6.1	-0.1	-8.8	-8.5
819	HP19 Ver. SCC1	9.7	-10.0	-4.6	-11.5	-10.5	-6.1	-0.1	-8.8	-8.5
820	HP20 Ver. SCC1	9.7	-10.0	-4.6	-11.5	-10.5	-6.1	-0.1	-8.8	-8.5
821	HP21 Ver. SCC1	9.7	-10.0	-4.6	-11.5	-10.5	-6.1	-0.1	-8.8	-8.5
822	HP22 Ver. SCC1	9.7	-10.0	-4.6	-11.5	-10.5	-6.1	-0.1	-8.8	-8.5
823	HP23 Ver. SCC1	9.7	-10.0	-4.6	-11.5	-10.5	-6.1	-0.1	-8.8	-8.5
824	HP24 Ver. SCC1	9.7	-10.0	-4.6	-11.5	-10.5	-6.1	-0.1	-8.8	-8.5
825	HP25 Ver. SCC1	9.7	-10.0	-4.6	-11.5	-10.5	-6.1	-0.1	-8.8	-8.5
826	HP26 Ver. SCC1	9.7	-10.3	-5.9	-11.5	-10.5	-6.6	-1.7	-8.8	-8.5
851	HP51 Hor. SCC2	9.1	-11.8	-11.0	-9.2	-6.2	-10.4	-9.6	-6.8	-4.1
852	HP52 Hor. SCC2	9.1	-12.8	-12.0	-10.2	-7.2	-10.2	-9.6	-7.1	-4.5
853	HP53 Hor. SCC2	9.1	-13.4	-12.7	-10.9	-7.8	-10.7	-10.0	-7.7	-5.0
854	HP54 Hor. SCC2	9.1	-12.2	-11.7	-9.8	-6.8	-10.8	-10.1	-7.7	-5.1
855	HP55 Hor. SCC2	9.1	-13.7	-12.8	-11.1	-8.0	-11.5	-10.7	-7.7	-5.1
856	HP56 Hor. SCC2	9.1	-13.7	-13.1	-11.2	-8.2	-11.5	-10.8	-7.2	-4.6
857	HP57 Hor. SCC2	9.1	-12.6	-12.0	-10.1	-7.1	-11.4	-10.7	-7.1	-4.5
858	HP57 Hor. SCC2	9.1	-13.5	-12.8	-11.0	-7.9	-11.3	-10.6	-7.0	-4.4
861	HP61 Ver. SCC2	9.7	-12.8	-12.4	-8.9	-3.5	-10.8	-10.4	-4.8	0.5
862	HP62 Ver. SCC2	9.7	-12.8	-12.4	-8.5	-2.3	-10.7	-10.4	-4.2	2.1
863	HP63 Ver. SCC2	9.7	-12.8	-12.4	-8.5	-2.3	-10.7	-10.4	-4.2	2.1

Controlled Distribution



REFERENCE : H-P-RP-AI-0040

DATE : 29/SEP/06

ISSUE : 06

Page : 235/405

NODE	LABEL	UFP	Case P SCC1 On		Case P SCC2 On		Case Q SCC1 On		Case Q SCC2 On	
			Min [°C]	Max [°C]	Min [°C]	Max [°C]	Min [°C]	Max [°C]	Min [°C]	Max [°C]
864	HP64 Ver. SCC2	9.7	-12.8	-12.4	-8.5	-2.3	-10.7	-10.4	-4.2	2.1
865	HP65 Ver. SCC2	9.7	-12.8	-12.4	-8.5	-2.3	-10.7	-10.4	-4.2	2.1
866	HP66 Ver. SCC2	9.7	-12.8	-12.4	-8.5	-2.3	-10.7	-10.4	-4.2	2.1
867	HP67 Ver. SCC2	9.7	-12.8	-12.4	-8.5	-2.3	-10.7	-10.4	-4.2	2.1
868	HP68 Ver. SCC2	9.7	-12.8	-12.4	-8.5	-2.3	-10.7	-10.4	-4.2	2.1
869	HP69 Ver. SCC2	9.7	-12.8	-12.4	-8.5	-2.3	-10.7	-10.4	-4.2	2.1
870	HP70 Ver. SCC2	9.7	-12.8	-12.4	-8.5	-2.3	-10.7	-10.4	-4.2	2.1
871	HP71 Ver. SCC2	9.7	-12.8	-12.4	-8.5	-2.3	-10.7	-10.4	-4.2	2.1
872	HP72 Ver. SCC2	9.7	-12.8	-12.4	-8.5	-2.3	-10.7	-10.4	-4.2	2.1
873	HP73 Ver. SCC2	9.7	-12.8	-12.4	-8.5	-2.3	-10.7	-10.4	-4.2	2.1
874	HP74 Ver. SCC2	9.7	-12.8	-12.4	-8.5	-2.3	-10.7	-10.4	-4.2	2.1
875	HP75 Ver. SCC2	9.7	-12.8	-12.4	-8.5	-2.3	-10.7	-10.4	-4.2	2.1
876	HP76 Ver. SCC2	9.7	-12.8	-12.4	-8.9	-3.5	-10.8	-10.4	-4.8	0.5
900	Helium Tank +Z	7.8	12.5	12.9	12.7	12.9	17.7	17.8	17.7	17.8
905	Helium Tank +Y	8.3	11.5	11.9	11.7	11.9	15.9	16.3	16.0	16.3
910	Helium Tank -Z	7.9	0.3	0.7	0.9	1.2	5.1	5.4	5.5	5.7
915	Helium Tank -Y	8.0	7.2	12.0	7.3	12.1	10.6	15.3	10.5	15.3
916	Helium Tank -Y	8.0	9.8	14.1	9.9	14.2	13.3	17.6	13.3	17.6
917	Helium Tank -Y	8.0	15.3	17.7	15.4	17.8	19.2	21.5	19.1	21.5
918	Helium Tank -Y	8.0	14.4	17.0	14.4	17.0	17.7	20.3	17.7	20.2
920	Prop. Tank +Y+Z Lower	8.0	21.2	21.7	21.5	21.8	26.9	27.3	27.0	27.3
925	Prop. Tank -Z Lower	8.1	21.5	22.1	21.8	22.2	27.9	28.4	28.1	28.4
930	Prop. Tank -Y+Z Lower	8.0	21.5	22.2	21.8	22.2	27.2	27.5	27.2	27.6
1133	FCV BODY MAIN D1A	7.8	45.0	46.7	45.0	46.8	51.5	53.2	51.5	53.2
1134	FCV BODY RED. D1B	7.9	44.2	46.7	44.2	46.7	50.5	53.1	50.6	53.1
1233	FCV BODY MAIN D2A	7.6	39.7	40.9	39.7	41.0	45.5	46.8	45.1	46.4
1234	FCV BODY RED. D2B	7.7	38.8	40.7	38.8	40.8	44.5	46.7	44.1	46.3
1333	FCV BODY MAIN F1A	7.9	35.6	38.0	35.3	37.8	40.3	42.9	40.1	42.7
1334	FCV BODY RED. F1B	8.0	36.3	39.7	36.0	39.4	41.1	44.7	40.8	44.4
1433	FCV BODY MAIN F2A	8.1	31.2	33.5	31.3	33.5	36.4	38.9	36.5	38.9
1434	FCV BODY RED. F2B	7.9	30.7	32.9	30.8	33.0	36.0	38.2	36.1	38.2
1533	FCV BODY MAIN U1A	9.2	15.7	16.0	15.7	16.0	17.6	17.9	17.6	17.8
1534	FCV BODY RED. U1B	9.3	15.7	22.7	15.7	22.7	17.5	17.7	17.5	17.7
1733	FCV BODY MAIN U2A	8.8	14.0	21.0	14.0	21.0	14.0	21.0	14.0	21.0
1734	FCV BODY RED. U2B	8.8	14.0	21.0	14.0	21.0	14.0	21.0	14.0	21.0
8508	1FCV BODY A1A	7.9	16.4	16.8	16.5	16.9	18.3	18.8	18.3	18.8
8608	1FCV BODY A1B	7.8	14.0	21.1	14.0	21.0	14.0	21.0	14.0	21.0
8708	1FCV BODY B1A	8.0	19.6	21.3	19.3	21.1	22.0	23.7	21.8	23.6
8808	1FCV BODY B1B	8.0	15.0	16.8	14.8	16.5	17.5	19.2	17.3	19.0
1840	RCS LINE #32 - LV1	8.0	22.0	23.0	22.0	23.0	22.6	23.5	22.6	23.5
1841	RCS LINE #32 - LV2	8.0	21.9	22.9	22.0	23.0	22.6	23.5	22.6	23.6

Controlled Distribution



REFERENCE : H-P-RP-AI-0040

DATE : 29/SEP/06

ISSUE : 06

Page : 236/405

NODE	LABEL	UFP	Case P SCC1 On		Case P SCC2 On		Case Q SCC1 On		Case Q SCC2 On	
			Min [°C]	Max [°C]	Min [°C]	Max [°C]	Min [°C]	Max [°C]	Min [°C]	Max [°C]
1842	RCS LINE #32 - LF	8.0	21.7	22.9	21.7	22.9	22.8	23.9	22.8	23.9
1843	RCS LINE #32 - PT	8.0	22.6	24.6	22.6	24.6	22.6	24.6	22.6	24.6
3921	LGA+Y HORN	8.3	-41.9	-41.8	-41.9	-41.8	-40.3	-40.2	-40.3	-40.2
3931	SAS HOUSING	9.2	7.0	7.2	7.1	7.2	9.4	9.5	9.4	9.5
3951	SAS2 HOUSING	7.5	51.3	52.0	51.4	52.1	61.1	61.9	61.1	61.9
3961	LGA+Y HORN	8.2	-72.2	-70.6	-72.2	-70.6	-70.6	-69.0	-70.7	-69.2
3966	SREM	8.2	11.0	11.4	11.2	11.4	15.3	15.5	15.3	15.5
3970	AAD_HOUSING	8.8	42.7	43.1	42.9	43.2	52.0	52.3	52.0	52.3
3986	MGA-X SEPTUM	8.5	82.5	121.2	82.5	121.1	82.5	121.2	82.5	121.1
3991	LGA-X HORN	7.2	81.5	82.0	81.5	82.0	89.6	90.2	89.6	90.2
5427	<27> -X FOOT	9.2	7.8	7.9	7.9	8.0	11.8	12.0	11.8	12.0
5428	<28> +Y FOOT	9.2	7.7	7.9	7.8	8.0	11.8	12.0	11.8	12.0
5429	<29> +X FOOT	9.2	7.3	7.5	7.4	7.5	11.3	11.5	11.4	11.5
5430	<30> -Y FOOT	9.2	7.5	7.7	7.7	7.8	11.6	11.8	11.6	11.8
5527	<27> -X FOOT	7.3	-2.1	-1.9	-2.0	-1.8	1.9	2.2	2.0	2.2
5528	<28> +Y FOOT	7.3	-2.2	-2.0	-2.1	-1.9	1.8	2.0	1.9	2.0
5529	<29> +X FOOT	7.3	-2.2	-2.0	-2.1	-1.9	1.8	2.1	1.9	2.0
5530	<30> -Y FOOT	7.2	-2.2	-2.0	-2.1	-1.9	1.8	2.0	1.8	2.0
8001	SA EXT -X/ext part	8.0	107.8	109.2	107.8	109.2	116.4	117.9	116.4	117.9
8002	SA EXT -X/ext part	8.0	109.0	110.2	109.0	110.2	117.7	118.9	117.7	118.9
8003	SA EXT -X/ext part	8.0	107.5	109.0	107.5	109.0	116.2	117.7	116.2	117.7
8004	SA EXT -X/ext part	7.5	107.1	108.6	107.1	108.6	115.7	117.2	115.7	117.2
8005	SA EXT -X/ext part	7.5	107.4	108.9	107.4	108.9	116.0	117.5	116.0	117.5
8006	SA EXT -X/ext part	7.5	105.9	108.9	105.9	108.9	114.5	117.5	114.5	117.5
8007	SA EXT -X/ext part	8.4	107.1	108.6	107.1	108.6	115.7	117.2	115.7	117.2
8008	SA EXT -X/ext part	8.4	107.4	108.9	107.4	108.9	116.0	117.5	116.0	117.5
8009	SA EXT -X/ext part	8.4	107.5	108.9	107.5	109.0	116.1	117.6	116.1	117.6
8010	SA EXT -X/ext part	8.1	105.5	107.4	105.5	107.4	114.2	116.0	114.2	116.0
8011	SA EXT -X/ext part	8.1	107.8	109.2	107.8	109.2	116.4	117.8	116.4	117.8
8012	SA EXT -X/ext part	8.1	108.1	109.1	108.1	109.1	116.7	117.7	116.7	117.7
8051	SA EXT +X/ext part	8.0	107.4	108.8	107.4	108.8	116.0	117.4	116.0	117.4
8052	SA EXT +X/ext part	8.0	108.7	109.8	108.7	109.8	117.3	118.5	117.3	118.5
8053	SA EXT +X/ext part	8.0	107.3	108.7	107.3	108.7	115.9	117.4	115.9	117.4
8054	SA EXT +X/ext part	7.6	106.7	108.2	106.7	108.2	115.3	116.8	115.3	116.8
8055	SA EXT +X/ext part	7.6	107.1	108.6	107.1	108.6	115.7	117.2	115.7	117.2
8056	SA EXT +X/ext part	7.6	105.6	108.6	105.6	108.6	114.2	117.2	114.2	117.1
8057	SA EXT +X/ext part	8.4	106.7	108.1	106.7	108.1	115.3	116.8	115.3	116.8
8058	SA EXT +X/ext part	8.4	107.1	108.6	107.1	108.6	115.7	117.2	115.7	117.2
8059	SA EXT +X/ext part	8.4	107.2	108.7	107.3	108.7	115.8	117.3	115.9	117.3
8060	SA EXT +X/ext part	8.1	105.1	107.0	105.1	107.0	113.8	115.6	113.8	115.6
8061	SA EXT +X/ext part	8.1	107.5	108.9	107.5	108.9	116.1	117.5	116.1	117.5

Controlled Distribution



REFERENCE : H-P-RP-AI-0040

DATE : 29/SEP/06

ISSUE : 06

Page : 237/405

NODE	LABEL	UFP	Case P SCC1 On		Case P SCC2 On		Case Q SCC1 On		Case Q SCC2 On	
			Min [°C]	Max [°C]	Min [°C]	Max [°C]	Min [°C]	Max [°C]	Min [°C]	Max [°C]
8062	SA EXT +X/ext part	8.1	107.9	108.8	107.9	108.8	116.4	117.4	116.4	117.4
8171	SA EXT +X/int part	8.0	110.8	111.7	110.9	111.7	119.5	120.4	119.5	120.4
8172	SA EXT +X/int part	8.0	107.2	108.2	107.2	108.2	115.7	116.7	115.7	116.7
8173	SA EXT +X/int part	8.0	108.0	110.1	108.0	110.1	116.6	118.8	116.6	118.8
8174	SA EXT +X/int part	7.6	106.0	110.0	106.0	110.0	114.6	118.7	114.6	118.7
8175	SA EXT +X/int part	7.6	106.3	110.4	106.3	110.4	114.9	119.1	114.9	119.1
8176	SA EXT +X/int part	7.6	107.1	110.4	107.1	110.4	115.6	119.1	115.6	119.1
8177	SA EXT +X/int part	8.4	107.2	110.4	107.2	110.4	115.7	119.0	115.7	119.0
8178	SA EXT +X/int part	8.4	107.5	109.8	107.5	109.8	116.2	118.5	116.2	118.5
8179	SA EXT +X/int part	8.4	108.5	109.7	108.5	109.7	117.2	118.4	117.1	118.4
8180	SA EXT +X/int part	8.1	111.4	112.1	111.4	112.1	120.1	120.8	120.1	120.8
8181	SA EXT +X/int part	8.1	109.2	110.5	109.2	110.5	118.0	119.1	118.0	119.1
8182	SA EXT +X/int part	8.1	110.3	111.2	110.3	111.2	119.0	119.8	119.0	119.8
8301	Central Solar Array -X	7.9	116.3	118.1	116.3	118.1	125.1	127.0	125.1	127.0
8302	Central Solar Array -X	7.9	115.5	116.9	115.5	116.9	124.2	125.8	124.2	125.8
8303	Central Solar Array -X	7.9	115.1	116.6	115.1	116.6	123.9	125.4	123.9	125.4
8304	Central Solar Array -X	8.0	115.0	116.5	115.0	116.5	123.8	125.3	123.8	125.3
8305	Central Solar Array -X	8.0	115.1	116.5	115.1	116.5	123.8	125.3	123.8	125.3
8306	Central Solar Array -X	8.0	115.1	116.6	115.1	116.6	123.9	125.4	123.9	125.4
8307	Central Solar Array -X	8.1	115.1	116.6	115.1	116.6	123.8	125.4	123.8	125.4
8308	Central Solar Array -X	8.1	115.1	116.8	115.1	116.8	123.9	125.6	123.9	125.6
8309	Central Solar Array -X	8.1	114.7	116.7	114.6	116.6	123.4	125.5	123.4	125.5
8310	Central Solar Array -X	7.9	115.1	116.6	115.1	116.6	123.8	125.4	123.8	125.4
8311	Central Solar Array -X	7.9	115.1	116.6	115.1	116.6	123.8	125.4	123.8	125.4
8312	Central Solar Array -X	7.9	115.2	116.7	115.2	116.7	124.0	125.5	124.0	125.5
8351	Central Solar Array +X	7.9	116.1	117.8	116.1	117.8	124.9	126.7	124.9	126.7
8352	Central Solar Array +X	7.9	115.3	116.8	115.3	116.8	124.0	125.6	124.0	125.6
8353	Central Solar Array +X	7.9	115.0	116.4	115.0	116.4	123.7	125.2	123.7	125.2
8354	Central Solar Array +X	8.0	114.8	116.3	114.8	116.3	123.6	125.1	123.6	125.1
8355	Central Solar Array +X	8.0	114.9	116.4	114.9	116.4	123.6	125.2	123.6	125.2
8356	Central Solar Array +X	8.0	115.0	116.4	115.0	116.4	123.7	125.2	123.7	125.2
8357	Central Solar Array +X	8.1	114.9	116.4	114.9	116.4	123.6	125.2	123.6	125.2
8358	Central Solar Array +X	8.1	114.9	116.6	114.9	116.6	123.7	125.4	123.7	125.4
8359	Central Solar Array +X	8.1	114.5	116.5	114.4	116.4	123.3	125.4	123.3	125.4
8360	Central Solar Array +X	7.9	114.9	116.4	114.9	116.4	123.6	125.2	123.6	125.2
8361	Central Solar Array +X	7.9	114.9	116.4	114.9	116.4	123.7	125.2	123.7	125.2
8362	Central Solar Array +X	7.9	115.1	116.6	115.1	116.6	123.8	125.4	123.8	125.4
8951	SA EXT -X/int part		111.0	111.8	111.0	111.8	119.7	120.6	119.7	120.6
8952	SA EXT -X/int part		107.3	108.3	107.3	108.3	115.9	116.9	115.9	116.9
8953	SA EXT -X/int part		108.1	110.2	108.1	110.2	116.8	119.0	116.8	119.0
8954	SA EXT -X/int part		106.2	110.2	106.2	110.2	114.8	118.9	114.8	118.9

Controlled Distribution



REFERENCE : H-P-RP-AI-0040

DATE : 29/SEP/06

ISSUE : 06

Page : 238/405

NODE	LABEL	UFP	Case P SCC1 On		Case P SCC2 On		Case Q SCC1 On		Case Q SCC2 On	
			Min [°C]	Max [°C]	Min [°C]	Max [°C]	Min [°C]	Max [°C]	Min [°C]	Max [°C]
8955	SA EXT -X/int part		106.5	110.6	106.5	110.6	115.1	119.3	115.1	119.3
8956	SA EXT -X/int part		107.3	110.6	107.3	110.6	115.8	119.3	115.8	119.3
8957	SA EXT -X/int part		107.4	110.6	107.4	110.6	115.9	119.3	115.9	119.3
8958	SA EXT -X/int part		107.7	110.0	107.7	110.0	116.4	118.7	116.4	118.7
8959	SA EXT -X/int part		108.7	109.9	108.7	109.9	117.4	118.6	117.4	118.6
8960	SA EXT -X/int part		111.5	112.2	111.5	112.2	120.2	120.9	120.2	120.9
8961	SA EXT -X/int part		109.5	110.8	109.5	110.8	118.3	119.5	118.3	119.5
8962	SA EXT -X/int part		110.4	111.4	110.4	111.4	119.2	120.0	119.2	120.0

Table 8.5.4.2-1 PLANCK – Attitude Change temperatures

Controlled Distribution



REFERENCE : H-P-RP-AI-0040

DATE : 29/SEP/06

ISSUE : 06

Page : 239/405

8.5.4.3 Redundancy Analysis

A series of additional analysis has been performed to verify the temperatures behaviour when the redundancy units are activated. In particular the following hot case analysis have been considered (SAA=0 deg):

Transient nominal analysis

- TT &C activation of line 2 (with – SCC2 on)
- DPU2 and REBA2 On (with – SCC2 on)
- In addition a case with both Star Tracker activated has been also performed. (with – SCC2 on)

In redundant case with both STR on, the **4K CEU** reach a temperature of 40.2°C (uncertainty included) vs 40.0° of maximum operative limit.

Controlled Distribution

REFERENCE : H-P-RP-AI-0040

DATE : 29/SEP/06

ISSUE : 06

Page : 240/405



Planck Redundant Analysis cases

NODE	LABEL	UFP	Red_1 STR Min	Red_2 REBA Min	Red_3 TT&C Min	Red 82_1 STR1 & 2 Tmax+UFP	Red 82_2 REBA2 DPU2 Tmax+UFP	Red 82_3 TT&C2 Tmax+UFP	TEMPERATURE LIMIT			
									MIN	MAX	MIN	MAX
									OPER.	OPER.	N.OPER.	N.OPER.
5427	STR_MY -X FOOT	9,2	14.0	12.1	10.0	23.2	21.3	19.2	-20,0	40,0	-30,0	50,0
5428	STR_MY +Y FOOT	9,2	14.0	12.1	10.0	23.2	21.3	19.2	-20,0	40,0	-30,0	50,0
5429	STR_MY +X FOOT	9,2	13.5	11.7	9.5	22.7	20.9	18.7	-20,0	40,0	-30,0	50,0
5430	STR_MY -Y FOOT	9,2	13.8	11.9	9.8	23.0	21.1	19.0	-20,0	40,0	-30,0	50,0
5527	STR_PY -X FOOT	7,3	17.6	-1.8	0.2	24.9	5.5	7.5	-20,0	40,0	-30,0	50,0
5528	STR_PY +Y FOOT	7,3	17.6	-1.9	0.0	24.9	5.4	7.3	-20,0	40,0	-30,0	50,0
5529	STR_PY +X FOOT	7,3	17.1	-2.0	0.0	24.4	5.4	7.3	-20,0	40,0	-30,0	50,0
5530	STR_PY -Y FOOT	7,2	17.4	-2.0	0.0	24.6	5.2	7.2	-20,0	40,0	-30,0	50,0
13	DPU1	8,1	16.4	0.6	13.9	24.5	8.7	22.0	-10,0	40,0	-20,0	50,0
14	DPU2	7,6	0.2	12.0	-1.6	7.8	19.6	6.0	-10,0	40,0	-20,0	50,0
101	DCCU	8	11.5	12.1	11.1	19.5	20.1	19.1	-10,0	40,0	-20,0	50,0
102	REBA2	8,5	0.2	15.6	-0.5	8.7	24.1	8.0	-20,0	50,0	-30,0	50,0
103	REBA1	7,8	10.1	-5.0	9.5	17.9	2.8	17.3	-20,0	50,0	-30,0	50,0
104	FOG (GEU)	8,3	27.5	28.1	26.7	35.8	36.4	35.0	0,0	45,0	-40,0	75,0
105	FOG (ICU)	8	14.9	13.4	14.1	22.9	21.4	22.1	0,0	45,0	-40,0	75,0
202	4K CAU	8,1	-1.0	-1.2	-1.2	7.1	7.0	6.9	-10,0	40,0	-20,0	50,0
203	4K CRU ex 4K PRE-REG	8,7	29.1	30.3	28.2	37.8	39.0	36.9	-10,0	40,0	-20,0	50,0
204	4K CDE ex CEU	9,3	28.9	28.8	28.7	38.2	38.1	38.0	-10,0	40,0	-20,0	50,0
205	REU	9,2	23.5	23.4	23.3	32.7	32.6	32.5	-10,0	40,0	-20,0	50,0
211	4K CCU Compress.1	11	46.3	46.2	46.1	57.3	57.2	57.1				
212	4K CCU Compress.2	10,5	40.9	40.8	40.7	51.4	51.3	51.2				

Controlled Distribution

REFERENCE : H-P-RP-AI-0040

DATE : 29/SEP/06

ISSUE : 06

Page : 241/405



NODE	LABEL	UFP	Red_1 STR Min	Red_2 REBA Min	Red_3 TT&C Min	Red 82_1 STR1 & 2 Tmax+UFP	Red 82_2 REBA2 DPU2 Tmax+UFP	Red 82_3 TT&C2 Tmax+UFP	TEMPERATURE LIMIT			
									MIN	MAX	MIN	MAX
									OPER.	OPER.	N.OPER.	N.OPER.
219	4K CCU I/F Bracket -X	9,1	16.9	16.8	16.7	26.0	25.9	25.8	-10,0	40,0	-20,0	40,0
220	4K CCU I/F Bracket +X	8,6	10.1	10.0	10.0	18.7	18.6	18.6	-10,0	40,0	-20,0	40,0
221	4K CCU I/F Strap -Z	9,9	24.7	24.6	24.5	34.6	34.5	34.4	-10,0	40,0	-20,0	40,0
222	4K CCU I/F Strap +Z	9,8	22.6	22.5	22.5	32.4	32.3	32.3	-10,0	40,0	-20,0	40,0
401	SCE1	9,3	-9.0	-9.0	-9.0	-9.0	-9.0	-9.0	-10,0	40,0	-20,0	50,0
402	SCE2	9,3	-4.6	-4.6	-4.6	-4.6	-4.6	-4.6	-10,0	40,0	-20,0	50,0
519	BEU	9,2	18.4	18.1	18.1	27.6	27.3	27.3	-20,0	40,0	-30,0	50,0
520	BEU	9,3	15.6	15.3	15.3	24.9	24.6	24.6	-20,0	40,0	-30,0	50,0
521	BEU	9,2	19.0	18.6	18.7	28.2	27.8	27.9	-20,0	40,0	-30,0	50,0
522	PAU	8,6	16.1	15.7	15.8	24.7	24.3	24.4	-10,0	30,0	-20,0	50,0
525	DAE POWER BOX	8,1	31.1	30.5	30.6	39.2	38.6	38.7	-20,0	50,0	-30,0	50,0
601	XPND_1	8,3	15.9	15.7	5.7	24.2	24.0	14.0	-10,0	50,0	-20,0	60,0
602	XPND_2	7,9	8.7	8.5	17.7	16.6	16.4	25.6	-10,0	50,0	-20,0	60,0
603	TWTA_1 BODY	8,8	31.5	31.4	-3.5	40.3	40.2	5.3	-20,0	60,0	-30,0	70,0
608	TWTA_1 HEAD	8,8	47.3	47.1	-2.5	56.1	55.9	6.3	-20,0	60,0	-30,0	70,0
604	TWTA_2 BODY	7,7	-6.0	-6.2	25.8	1.7	1.5	33.5	-20,0	60,0	-30,0	70,0
609	TWTA_2 HEAD	7,7	-5.9	-6.1	41.0	1.8	1.6	48.7	-20,0	60,0	-30,0	70,0
605	RFDN	7,9	9.9	9.7	9.1	17.8	17.6	17.0	-25,0	55,0	-35,0	65,0
606	EPC1	8,3	14.7	14.5	0.3	23.0	22.8	8.6	-20,0	60,0	-30,0	70,0
607	EPC2	7,7	-0.5	-0.7	10.3	7.2	7.0	18.0	-20,0	60,0	-30,0	70,0
701	CDMU	8,1	18.6	17.5	17.9	26.7	25.6	26.0	-10,0	45,0	-20,0	55,0
702	ACC	8	11.0	9.9	10.4	19.0	17.9	18.4	-10,0	45,0	-20,0	55,0
703	BATT	8	17.9	17.4	17.7	25.9	25.4	25.7	0,0	35,0	N/A	N/A

Controlled Distribution

REFERENCE : H-P-RP-AI-0040

DATE : 29/SEP/06

ISSUE : 06

Page : 242/405



NODE	LABEL	UFP	Red_1 STR Min	Red_2 REBA Min	Red_3 TT&C Min	Red 82_1 STR1 & 2 Tmax+UFP	Red 82_2 REBA2 DPU2 Tmax+UFP	Red 82_3 TT&C2 Tmax+UFP	TEMPERATURE LIMIT			
									MIN	MAX	MIN	MAX
									OPER.	OPER.	N.OPER.	N.OPER.
704	PCDU	8,7	32.4	31.9	32.0	41.1	40.6	40.7	-10,0	45,0	-20,0	55,0
705	CRS1	8,6	48.6	48.6	48.6	48.6	48.6	48.6	0,0	50,0	-25,0	55,0
706	CRS2	8,7	48.6	48.6	48.6	48.6	48.6	48.6	0,0	50,0	-25,0	55,0
707	CRS3	8,7	35.6	35.6	35.6	35.6	35.6	35.6	0,0	50,0	-25,0	55,0
900	Helium Tank +Z	7,8	16.4	16.0	15.2	24.2	23.8	23.0	-10,0	40,0	-20,0	50,0
905	Helium Tank +Y	8,3	14.1	13.9	13.9	22.4	22.2	22.2	-10,0	40,0	-20,0	50,0
910	Helium Tank -Z	7,9	4.1	4.0	4.0	12.0	11.9	11.9	-10,0	40,0	-20,0	50,0
915	Helium Tank -Y	8	14.0	13.7	12.2	22.0	21.7	20.2	-10,0	40,0	-20,0	50,0
920	Prop. Tank +Y+Z Lower	8	24.6	24.3	24.3	32.6	32.3	32.3	10,0	50,0	10,0	50,0
925	Prop. Tank -Z Lower	8,1	25.2	24.9	24.9	33.3	33.0	33.0	10,0	50,0	10,0	50,0
930	Prop. Tank -Y+Z Lower	8	25.0	24.6	24.6	33.0	32.6	32.6	10,0	50,0	10,0	50,0
311	SCC1 - Outer shell1	9,9	-8.5	-8.6	-8.5	-8.5	-8.6	-8.5				
312	SCC1 - Outer shell2	9,9	-8.6	-8.6	-8.5	-8.6	-8.6	-8.5				
313	SCC1 - Outer shell3	9,9	-8.6	-8.6	-8.5	-8.6	-8.6	-8.5				
314	SCC1 - Outer shell4	9,9	-8.6	-8.6	-8.5	-8.6	-8.6	-8.5				
315	SCC1 - Outer shell5	9,9	-8.6	-8.6	-8.5	-8.6	-8.6	-8.5				
316	SCC1 - Outer shell6	9,9	-8.5	-8.5	-8.5	-8.5	-8.5	-8.5				
811	HP11 Ver. SCC1	9,7	-8.5	-8.5	-8.5	-8.5	-8.5	-8.5	-13,0	7,0	-20,0	50,0
812	HP12 Ver. SCC1	9,7	-8.6	-8.6	-8.5	-8.6	-8.6	-8.5	-13,0	7,0	-20,0	50,0
813	HP13 Ver. SCC1	9,7	-8.6	-8.6	-8.5	-8.6	-8.6	-8.5	-13,0	7,0	-20,0	50,0
814	HP14 Ver. SCC1	9,7	-8.6	-8.6	-8.5	-8.6	-8.6	-8.5	-13,0	7,0	-20,0	50,0
815	HP15 Ver. SCC1	9,7	-8.6	-8.6	-8.5	-8.6	-8.6	-8.5	-13,0	7,0	-20,0	50,0
816	HP16 Ver. SCC1	9,7	-8.6	-8.6	-8.5	-8.6	-8.6	-8.5	-13,0	7,0	-20,0	50,0

Controlled Distribution

REFERENCE : H-P-RP-AI-0040

DATE : 29/SEP/06

ISSUE : 06 Page : 243/405



NODE	LABEL	UFP	Red_1 STR Min	Red_2 REBA Min	Red_3 TT&C Min	Red 82_1 STR1 & 2 Tmax+UFP	Red 82_2 REBA2 DPU2 Tmax+UFP	Red 82_3 TT&C2 Tmax+UFP	TEMPERATURE LIMIT			
									MIN	MAX	MIN	MAX
									OPER.	OPER.	N.OPER.	N.OPER.
817	HP17 Ver. SCC1	9,7	-8.6	-8.6	-8.5	-8.6	-8.6	-8.5	-13,0	7,0	-20,0	50,0
818	HP18 Ver. SCC1	9,7	-8.6	-8.6	-8.5	-8.6	-8.6	-8.5	-13,0	7,0	-20,0	50,0
819	HP19 Ver. SCC1	9,7	-8.6	-8.6	-8.5	-8.6	-8.6	-8.5	-13,0	7,0	-20,0	50,0
820	HP20 Ver. SCC1	9,7	-8.6	-8.6	-8.5	-8.6	-8.6	-8.5	-13,0	7,0	-20,0	50,0
821	HP21 Ver. SCC1	9,7	-8.6	-8.6	-8.5	-8.6	-8.6	-8.5	-13,0	7,0	-20,0	50,0
822	HP22 Ver. SCC1	9,7	-8.6	-8.6	-8.5	-8.6	-8.6	-8.5	-13,0	7,0	-20,0	50,0
823	HP23 Ver. SCC1	9,7	-8.6	-8.6	-8.5	-8.6	-8.6	-8.5	-13,0	7,0	-20,0	50,0
824	HP24 Ver. SCC1	9,7	-8.6	-8.6	-8.5	-8.6	-8.6	-8.5	-13,0	7,0	-20,0	50,0
825	HP25 Ver. SCC1	9,7	-8.6	-8.6	-8.5	-8.6	-8.6	-8.5	-13,0	7,0	-20,0	50,0
826	HP26 Ver. SCC1	9,7	-8.5	-8.5	-8.5	-8.5	-8.5	-8.5	-13,0	7,0	-20,0	50,0
801	HP1 Hor. SCC1	9,3	-8.0	-8.0	-7.9	-8.0	-8.0	-7.9				
802	HP2 Hor. SCC1	9,3	-8.4	-8.4	-8.4	-8.4	-8.4	-8.4				
803	HP3 Hor. SCC1	9,3	-9.2	-9.2	-9.2	-9.2	-9.2	-9.2				
804	HP4 Hor. SCC1	9,3	-9.3	-9.3	-9.2	-9.3	-9.3	-9.2				
805	HP5 Hor. SCC1	9,3	-8.9	-8.9	-8.9	-8.9	-8.9	-8.9				
806	HP6 Hor. SCC1	9,3	-7.9	-7.9	-7.9	-7.9	-7.9	-7.9				
807	HP7 Hor. SCC1	9,3	-7.8	-7.8	-7.8	-7.8	-7.8	-7.8				
808	HP7 Hor. SCC1	9,3	-7.4	-7.4	-7.4	-7.4	-7.4	-7.4				
511	SCC2 - Outer shell1	9,1	23.6	23.6	23.6	23.6	23.6	23.6				
512	SCC2 - Outer shell2	9,1	23.7	23.7	23.7	23.7	23.7	23.7				
513	SCC2 - Outer shell3	9,1	23.7	23.7	23.7	23.7	23.7	23.7				
514	SCC2 - Outer shell4	9,1	23.7	23.7	23.7	23.7	23.7	23.7				
515	SCC2 - Outer shell5	9,1	23.6	23.6	23.7	23.6	23.6	23.7				

Controlled Distribution

REFERENCE : H-P-RP-AI-0040

DATE : 29/SEP/06

ISSUE : 06

Page : 244/405



NODE	LABEL	UFP	Red_1 STR Min	Red_2 REBA Min	Red_3 TT&C Min	Red 82_1 STR1 & 2 Tmax+UFP	Red 82_2 REBA2 DPU2 Tmax+UFP	Red 82_3 TT&C2 Tmax+UFP	TEMPERATURE LIMIT			
									MIN	MAX	MIN	MAX
									OPER.	OPER.	N.OPER.	N.OPER.
516	SCC2 - Outer shell6	9,1	23.7	23.7	23.7	23.7	23.7	23.7				
861	HP61 Ver. SCC2	9,7	0.5	0.5	0.5	0.5	0.5	0.5	-13,0	7,0	-20,0	50,0
862	HP62 Ver. SCC2	9,7	2.1	2.1	2.1	2.1	2.1	2.1	-13,0	7,0	-20,0	50,0
863	HP63 Ver. SCC2	9,7	2.1	2.1	2.1	2.1	2.1	2.1	-13,0	7,0	-20,0	50,0
864	HP64 Ver. SCC2	9,7	2.1	2.1	2.1	2.1	2.1	2.1	-13,0	7,0	-20,0	50,0
865	HP65 Ver. SCC2	9,7	2.1	2.1	2.1	2.1	2.1	2.1	-13,0	7,0	-20,0	50,0
866	HP66 Ver. SCC2	9,7	2.1	2.1	2.1	2.1	2.1	2.1	-13,0	7,0	-20,0	50,0
867	HP67 Ver. SCC2	9,7	2.1	2.1	2.1	2.1	2.1	2.1	-13,0	7,0	-20,0	50,0
868	HP68 Ver. SCC2	9,7	2.1	2.1	2.1	2.1	2.1	2.1	-13,0	7,0	-20,0	50,0
869	HP69 Ver. SCC2	9,7	2.1	2.1	2.1	2.1	2.1	2.1	-13,0	7,0	-20,0	50,0
870	HP70 Ver. SCC2	9,7	2.1	2.1	2.1	2.1	2.1	2.1	-13,0	7,0	-20,0	50,0
871	HP71 Ver. SCC2	9,7	2.1	2.1	2.1	2.1	2.1	2.1	-13,0	7,0	-20,0	50,0
872	HP72 Ver. SCC2	9,7	2.1	2.1	2.1	2.1	2.1	2.1	-13,0	7,0	-20,0	50,0
873	HP73 Ver. SCC2	9,7	2.1	2.1	2.1	2.1	2.1	2.1	-13,0	7,0	-20,0	50,0
874	HP74 Ver. SCC2	9,7	2.1	2.1	2.1	2.1	2.1	2.1	-13,0	7,0	-20,0	50,0
875	HP75 Ver. SCC2	9,7	2.1	2.1	2.1	2.1	2.1	2.1	-13,0	7,0	-20,0	50,0
876	HP76 Ver. SCC2	9,7	0.5	0.5	0.5	0.5	0.5	0.5	-13,0	7,0	-20,0	50,0
851	HP51 Hor. SCC2	9,1	-4.1	-4.1	-4.1	-4.1	-4.1	-4.1				
852	HP52 Hor. SCC2	9,1	-4.5	-4.6	-4.5	-4.5	-4.6	-4.5				
853	HP53 Hor. SCC2	9,1	-5.1	-5.1	-5.0	-5.1	-5.1	-5.0				
854	HP54 Hor. SCC2	9,1	-5.1	-5.1	-5.1	-5.1	-5.1	-5.1				
855	HP55 Hor. SCC2	9,1	-5.1	-5.1	-5.1	-5.1	-5.1	-5.1				
856	HP56 Hor. SCC2	9,1	-4.6	-4.6	-4.6	-4.6	-4.6	-4.6				

Controlled Distribution

REFERENCE : H-P-RP-AI-0040

DATE : 29/SEP/06

ISSUE : 06

Page : 245/405



NODE	LABEL	UFP	Red_1 STR Min	Red_2 REBA Min	Red_3 TT&C Min	Red 82_1 STR1 & 2 Tmax+UFP	Red 82_2 REBA2 DPU2 Tmax+UFP	Red 82_3 TT&C2 Tmax+UFP	TEMPERATURE LIMIT			
									MIN	MAX	MIN	MAX
									OPER.	OPER.	N.OPER.	N.OPER.
857	HP57 Hor. SCC2	9,1	-4.5	-4.5	-4.5	-4.5	-4.5	-4.5				
858	HP57 Hor. SCC2	9,1	-4.4	-4.4	-4.4	-4.4	-4.4	-4.4				
3931	SAS1 HOUSING	9,2	8.3	8.2	8.2	17.5	17.4	17.4	-70,0	80,0	-80,0	90,0
3951	SAS2 HOUSING	7,5	59.4	58.7	58.8	66.9	66.2	66.3	-70,0	80,0	-80,0	90,0
3921	LGA+Y HORN	8,3	-40.3	-40.4	-40.4	-32.0	-32.1	-32.1	-150,0	120,0	-150,0	120,0
3961	LGA-Y HORN	8,2	-69.2	-69.3	-65.0	-61.0	-61.1	-56.8	-150,0	120,0	-150,0	120,0
3991	LGA-X HORN	7,2	89.8	89.8	89.8	97.0	97.0	97.0	-150,0	120,0	-150,0	120,0
3986	MGA-X SEPTUM	8,5	171.4	171.4	171.4	179.9	179.9	179.9	-150,0	150,0	-150,0	150,0
3966	SREM	8,2	13.7	14.0	13.3	21.9	22.2	21.5	-10,0	50,0	-45,0	90,0
3970	AAD_HOUSING	8,8	49.5	48.8	48.8	58.3	57.6	57.6	-70,0	70,0	-80,0	80,0
8508	1FCV BODY A1A	7,9	18.5	16.8	17.8	26.4	24.7	25.7	10,0	60,0	10,0	70,0
8608	1FCV BODY A1B	7,8	21.1	21.1	21.1	28.9	28.9	28.9	10,0	60,0	10,0	70,0
8708	1FCV BODY B1A	8	22.7	22.4	21.2	30.7	30.4	29.2	10,0	60,0	10,0	70,0
8808	1FCV BODY B1B	8	18.2	17.9	16.7	26.2	25.9	24.7	10,0	60,0	10,0	70,0
1133	FCV BODY MAIN D1A	7,8	51.8	49.7	50.5	59.6	57.5	58.3	10,0	60,0	10,0	70,0
1134	FCV BODY RED. D1B	7,9	50.9	48.8	49.6	58.8	56.7	57.5	10,0	60,0	10,0	70,0
1233	FCV BODY MAIN D2A	7,6	46.2	46.2	46.2	53.8	53.8	53.8	10,0	60,0	10,0	70,0
1234	FCV BODY RED. D2B	7,7	46.1	46.1	46.1	53.8	53.8	53.8	10,0	60,0	10,0	70,0
1333	FCV BODY MAIN F1A	7,9	40.6	40.4	42.0	48.5	48.3	49.9	10,0	60,0	10,0	70,0
1334	FCV BODY RED. F1B	8	41.3	41.2	42.7	49.3	49.2	50.7	10,0	60,0	10,0	70,0
1433	FCV BODY MAIN F2A	8,1	36.3	37.1	35.3	44.4	45.2	43.4	10,0	60,0	10,0	70,0
1434	FCV BODY RED. F2B	7,9	35.8	36.7	34.8	43.7	44.6	42.7	10,0	60,0	10,0	70,0
1533	FCV BODY MAIN U1A	9,2	16.5	16.5	16.4	25.7	25.7	25.6	10,0	60,0	10,0	70,0

Controlled Distribution

REFERENCE : H-P-RP-AI-0040

DATE : 29/SEP/06

ISSUE : 06

Page : 246/405



NODE	LABEL	UFP	Red_1 STR Min	Red_2 REBA Min	Red_3 TT&C Min	Red 82_1 STR1 & 2 Tmax+UFP	Red 82_2 REBA2 DPU2 Tmax+UFP	Red 82_3 TT&C2 Tmax+UFP	TEMPERATURE LIMIT			
									MIN	MAX	MIN	MAX
									OPER.	OPER.	N.OPER.	N.OPER.
1534	FCV BODY RED. U1B	9,3	16.4	16.3	16.3	25.7	25.6	25.6	10,0	60,0	10,0	70,0
1733	FCV BODY MAIN U2A	8,8	21.0	21.0	21.0	29.8	29.8	29.8	10,0	60,0	10,0	70,0
1734	FCV BODY RED. U2B	8,8	21.0	21.0	21.0	29.8	29.8	29.8	10,0	60,0	10,0	70,0
1800	RCS LINE #33	8	25.5	26.0	25.6	33.5	34.0	33.6	10,0	50,0		
1801	RCS LINE #33	8	25.5	26.0	25.6	33.5	34.0	33.6	10,0	50,0		
1802	RCS LINE #33	8	25.5	26.0	25.6	33.5	34.0	33.6	10,0	50,0		
1803	RCS LINE #33	8	25.5	26.0	25.6	33.5	34.0	33.6	10,0	50,0		
1804	RCS LINE #33	8	25.5	26.0	25.6	33.5	34.0	33.6	10,0	50,0		
1805	RCS LINE #33	8	25.9	26.5	25.8	33.9	34.5	33.8	10,0	50,0		
1806	RCS LINE #33	8	24.0	24.8	23.6	32.0	32.8	31.6	10,0	50,0		
1807	RCS LINE #33	8	23.7	23.8	23.0	31.7	31.8	31.0	10,0	50,0		
1808	RCS LINE #33	8	25.2	26.7	24.6	33.2	34.7	32.6	10,0	50,0		
1809	RCS LINE #33	8	37.0	38.2	36.3	45.0	46.2	44.3	10,0	50,0		
1810	RCS LINE #33	8	26.7	26.6	26.6	34.7	34.6	34.6	10,0	50,0		
1811	RCS LINE #33	8	24.0	24.0	24.0	32.0	32.0	32.0	10,0	50,0		
1812	RCS LINE #33	8	24.0	24.0	24.0	32.0	32.0	32.0	10,0	50,0		
1813	RCS LINE #33	8	24.4	24.6	24.4	32.4	32.6	32.4	10,0	50,0		
1814	RCS LINE #33	8	27.7	27.7	27.6	35.7	35.7	35.6	10,0	50,0		
1815	RCS LINE #33	8	28.3	28.8	28.4	36.3	36.8	36.4	10,0	50,0		
1816	RCS LINE #33	8	25.5	26.0	25.6	33.5	34.0	33.6	10,0	50,0		
1817	RCS LINE #34	8	29.6	29.7	29.5	37.6	37.7	37.5	10,0	50,0		
1818	RCS LINE #34	8	32.3	32.5	32.4	40.3	40.5	40.4	10,0	50,0		
1819	RCS LINE #34	8	30.8	30.9	30.8	38.8	38.9	38.8	10,0	50,0		

Controlled Distribution

REFERENCE : H-P-RP-AI-0040

DATE : 29/SEP/06

ISSUE : 06

Page : 247/405

NODE	LABEL	UFP	Red_1 STR Min	Red_2 REBA Min	Red_3 TT&C Min	Red 82_1 STR1 & 2 Tmax+UFP	Red 82_2 REBA2 DPU2 Tmax+UFP	Red 82_3 TT&C2 Tmax+UFP	TEMPERATURE LIMIT			
									MIN	MAX	MIN	MAX
									OPER.	OPER.	N.OPER.	N.OPER.
1820	RCS LINE #34	8	30.4	30.4	30.4	38.4	38.4	38.4	10,0	50,0		
1821	RCS LINE #34	8	30.9	30.9	30.9	38.9	38.9	38.9	10,0	50,0		
1822	RCS LINE #34	8	30.9	31.0	31.0	38.9	39.0	39.0	10,0	50,0		
1823	RCS LINE #34	8	27.2	27.2	27.2	35.2	35.2	35.2	10,0	50,0		
1824	RCS LINE #34	8	27.2	27.2	27.2	35.2	35.2	35.2	10,0	50,0		
1825	RCS LINE #34	8	27.2	27.2	27.2	35.2	35.2	35.2	10,0	50,0		
1826	RCS LINE #34	8	29.0	29.0	29.0	37.0	37.0	37.0	10,0	50,0		
1827	RCS LINE #34	8	29.0	29.0	29.0	37.0	37.0	37.0	10,0	50,0		
1828	RCS LINE #34	8	29.0	29.0	29.0	37.0	37.0	37.0	10,0	50,0		
1830	RCS LINE #34	8	29.7	29.8	29.7	37.7	37.8	37.7	10,0	50,0		
1831	RCS LINE #34	8	28.8	28.9	28.8	36.8	36.9	36.8	10,0	50,0		
1832	RCS LINE #34	8	27.6	27.8	27.6	35.6	35.8	35.6	10,0	50,0		
1833	RCS LINE #34	8	29.3	29.4	29.3	37.3	37.4	37.3	10,0	50,0		
1835	RCS LINE #34	8	31.1	31.4	31.2	39.1	39.4	39.2	10,0	50,0		
1836	RCS LINE #34	8	29.3	29.4	29.3	37.3	37.4	37.3	10,0	50,0		
1837	RCS LINE #34	8	28.4	28.6	28.4	36.4	36.6	36.4	10,0	50,0		
1838	RCS LINE #34	8	27.9	27.8	27.8	35.9	35.8	35.8	10,0	50,0		
1839	RCS LINE #34	8	28.9	29.0	28.9	36.9	37.0	36.9	10,0	50,0		
1846	RCS LINE #34	8	28.6	28.8	28.8	36.6	36.8	36.8	10,0	50,0		
1847	RCS LINE #34	8	25.1	25.3	25.3	33.1	33.3	33.3	10,0	50,0		
1848	RCS LINE #34	8	21.4	21.4	21.4	29.4	29.4	29.4	10,0	50,0		
1949	RCS LINE #34	8	29.4	29.4	29.4	37.4	37.4	37.4	10,0	50,0		
1950	RCS LINE #34	8	29.5	29.5	29.5	37.5	37.5	37.5	10,0	50,0		

Controlled Distribution

REFERENCE : H-P-RP-AI-0040

DATE : 29/SEP/06

ISSUE : 06 Page : 248/405



NODE	LABEL	UFP	Red_1 STR Min	Red_2 REBA Min	Red_3 TT&C Min	Red 82_1 STR1 & 2 Tmax+UFP	Red 82_2 REBA2 DPU2 Tmax+UFP	Red 82_3 TT&C2 Tmax+UFP	TEMPERATURE LIMIT			
									MIN	MAX	MIN	MAX
									OPER.	OPER.	N.OPER.	N.OPER.
1840	RCS LINE #32 - LV1	8	23.3	23.3	23.3	31.3	31.3	31.3	10,0	50,0		
1841	RCS LINE #32 - LV2	8	23.3	23.3	23.3	31.3	31.3	31.3	10,0	50,0		
1842	RCS LINE #32 - LF	8	23.5	23.5	23.4	31.5	31.5	31.4	10,0	50,0		
1843	RCS LINE #32 - PT	8	24.6	24.6	24.6	32.6	32.6	32.6	10,0	50,0		
1844	RCS LINE #46	8	24.1	24.0	24.0	32.1	32.0	32.0	10,0	50,0		
1849	RCS LINE #46	8	24.1	24.0	24.0	32.1	32.0	32.0	10,0	50,0		
1850	RCS LINE #46	8	24.1	24.0	24.0	32.1	32.0	32.0	10,0	50,0		
1851	RCS LINE #46	8	24.1	24.0	24.0	32.1	32.0	32.0	10,0	50,0		
1852	RCS LINE #46	8	24.1	24.0	24.0	32.1	32.0	32.0	10,0	50,0		
1853	RCS LINE #46	8	24.0	23.9	23.9	32.0	31.9	31.9	10,0	50,0		
1854	RCS LINE #46	8	25.2	25.1	25.2	33.2	33.1	33.2	10,0	50,0		
1855	RCS LINE #46	8	41.8	41.5	41.5	49.8	49.5	49.5	10,0	50,0		
1856	RCS LINE #46	8	41.8	41.5	41.5	49.8	49.5	49.5	10,0	50,0		
1857	RCS LINE #46	8	41.8	41.5	41.5	49.8	49.5	49.5	10,0	50,0		
1858	RCS LINE #46	8	41.8	41.5	41.5	49.8	49.5	49.5	10,0	50,0		
1859	RCS LINE #46	8	41.8	41.5	41.5	49.8	49.5	49.5	10,0	50,0		
1860	RCS LINE #46	8	41.5	41.3	41.3	49.5	49.3	49.3	10,0	50,0		
1861	RCS LINE #46	8	42.8	42.6	42.6	50.8	50.6	50.6	10,0	50,0		
1862	RCS LINE #46	8	33.5	33.2	33.3	41.5	41.2	41.3	10,0	50,0		
1863	RCS LINE #46	8	39.7	39.5	39.5	47.7	47.5	47.5	10,0	50,0		
1864	RCS LINE #46	8	39.7	39.5	39.5	47.7	47.5	47.5	10,0	50,0		
1865	RCS LINE #46	8	39.7	39.5	39.5	47.7	47.5	47.5	10,0	50,0		
1866	RCS LINE #46	8	39.7	39.5	39.5	47.7	47.5	47.5	10,0	50,0		

Controlled Distribution

REFERENCE : H-P-RP-AI-0040

DATE : 29/SEP/06

ISSUE : 06 Page : 249/405



NODE	LABEL	UFP	Red_1 STR Min	Red_2 REBA Min	Red_3 TT&C Min	Red 82_1 STR1 & 2 Tmax+UFP	Red 82_2 REBA2 DPU2 Tmax+UFP	Red 82_3 TT&C2 Tmax+UFP	TEMPERATURE LIMIT			
									MIN	MAX	MIN	MAX
									OPER.	OPER.	N.OPER.	N.OPER.
1867	RCS LINE #46	8	39.7	39.5	39.5	47.7	47.5	47.5	10,0	50,0		
1868	RCS LINE #46	8	39.7	39.5	39.5	47.7	47.5	47.5	10,0	50,0		
1869	RCS LINE #46	8	39.4	39.2	39.2	47.4	47.2	47.2	10,0	50,0		
1870	RCS LINE #46	8	39.4	39.2	39.2	47.4	47.2	47.2	10,0	50,0		
1871	RCS LINE #46	8	39.4	39.2	39.2	47.4	47.2	47.2	10,0	50,0		
1872	RCS LINE #46	8	31.9	31.6	31.6	39.9	39.6	39.6	10,0	50,0		
1873	RCS LINE #46	8	31.6	31.3	31.4	39.6	39.3	39.4	10,0	50,0		
1874	RCS LINE #46	8	33.8	33.5	33.5	41.8	41.5	41.5	10,0	50,0		
1875	RCS LINE #46	8	35.3	35.0	35.0	43.3	43.0	43.0	10,0	50,0		
1876	RCS LINE #46	8	30.3	30.2	30.2	38.3	38.2	38.2	10,0	50,0		
1877	RCS LINE #46	8	20.1	20.1	20.1	28.1	28.1	28.1	10,0	50,0		
1878	RCS LINE #46	8	44.8	44.8	44.8	52.8	52.8	52.8	10,0	50,0		
1879	RCS LINE #46	8	46.3	46.3	46.3	54.3	54.3	54.3	10,0	50,0		
1880	RCS LINE #47	8	20.1	20.1	20.1	28.1	28.1	28.1	10,0	50,0		
1881	RCS LINE #47	8	20.1	20.1	20.1	28.1	28.1	28.1	10,0	50,0		
1882	RCS LINE #47	8	20.1	20.1	20.1	28.1	28.1	28.1	10,0	50,0		
1883	RCS LINE #47	8	20.1	20.1	20.1	28.1	28.1	28.1	10,0	50,0		
1884	RCS LINE #47	8	20.1	20.1	20.1	28.1	28.1	28.1	10,0	50,0		
1885	RCS LINE #47	8	20.1	20.1	20.1	28.1	28.1	28.1	10,0	50,0		
1886	RCS LINE #47	8	28.1	28.0	28.7	36.1	36.0	36.7	10,0	50,0		
1887	RCS LINE #47	8	28.1	28.0	28.7	36.1	36.0	36.7	10,0	50,0		
1888	RCS LINE #47	8	35.2	35.1	35.1	43.2	43.1	43.1	10,0	50,0		
1889	RCS LINE #47	8	35.2	35.1	35.1	43.2	43.1	43.1	10,0	50,0		

Controlled Distribution

REFERENCE : H-P-RP-AI-0040

DATE : 29/SEP/06

ISSUE : 06 Page : 250/405



NODE	LABEL	UFP	Red_1 STR Min	Red_2 REBA Min	Red_3 TT&C Min	Red 82_1 STR1 & 2 Tmax+UFP	Red 82_2 REBA2 DPU2 Tmax+UFP	Red 82_3 TT&C2 Tmax+UFP	TEMPERATURE LIMIT			
									MIN	MAX	MIN	MAX
									OPER.	OPER.	N.OPER.	N.OPER.
1890	RCS LINE #47	8	35.2	35.1	35.1	43.2	43.1	43.1	10,0	50,0		
1891	RCS LINE #47	8	35.2	35.1	35.1	43.2	43.1	43.1	10,0	50,0		
1892	RCS LINE #47	8	35.2	35.1	35.1	43.2	43.1	43.1	10,0	50,0		
1893	RCS LINE #47	8	35.2	35.1	35.1	43.2	43.1	43.1	10,0	50,0		
1894	RCS LINE #47	8	30.9	30.8	31.5	38.9	38.8	39.5	10,0	50,0		
1895	RCS LINE #47	8	30.9	30.8	31.5	38.9	38.8	39.5	10,0	50,0		
1896	RCS LINE #47	8	30.8	30.8	31.4	38.8	38.8	39.4	10,0	50,0		
1897	RCS LINE #47	8	34.6	34.5	34.5	42.6	42.5	42.5	10,0	50,0		
1898	RCS LINE #47	8	34.6	34.5	34.5	42.6	42.5	42.5	10,0	50,0		
1899	RCS LINE #47	8	34.6	34.5	34.5	42.6	42.5	42.5	10,0	50,0		
1900	RCS LINE #47	8	34.6	34.5	34.5	42.6	42.5	42.5	10,0	50,0		
1901	RCS LINE #47	8	34.6	34.5	34.5	42.6	42.5	42.5	10,0	50,0		
1902	RCS LINE #47	8	34.6	34.5	34.5	42.6	42.5	42.5	10,0	50,0		
1903	RCS LINE #47	8	30.3	30.3	30.9	38.3	38.3	38.9	10,0	50,0		
1904	RCS LINE #47	8	30.3	30.3	30.9	38.3	38.3	38.9	10,0	50,0		
1905	RCS LINE #47	8	30.3	30.3	30.9	38.3	38.3	38.9	10,0	50,0		
1906	RCS LINE #47	8	37.7	37.7	38.3	45.7	45.7	46.3	10,0	50,0		
1907	RCS LINE #47	8	38.9	38.8	39.6	46.9	46.8	47.6	10,0	50,0		
1908	RCS LINE #47	8	29.6	29.4	30.7	37.6	37.4	38.7	10,0	50,0		
1909	RCS LINE #47	8	36.3	36.3	38.0	44.3	44.3	46.0	10,0	50,0		
1910	RCS LINE #47	8	43.5	43.4	45.0	51.5	51.4	53.0	10,0	50,0		
1911	RCS LINE #47	8	25.7	25.5	24.3	33.7	33.5	32.3	10,0	50,0		
1912	RCS LINE #47	8	31.7	31.6	30.6	39.7	39.6	38.6	10,0	50,0		

Controlled Distribution

REFERENCE : H-P-RP-AI-0040

DATE : 29/SEP/06

ISSUE : 06 Page : 251/405



NODE	LABEL	UFP	Red_1 STR Min	Red_2 REBA Min	Red_3 TT&C Min	Red 82_1 STR1 & 2 Tmax+UFP	Red 82_2 REBA2 DPU2 Tmax+UFP	Red 82_3 TT&C2 Tmax+UFP	TEMPERATURE LIMIT			
									MIN	MAX	MIN	MAX
									OPER.	OPER.	N.OPER.	N.OPER.
1913	RCS LINE #47	8	30.8	30.7	30.7	38.8	38.7	38.7	10,0	50,0		
1914	RCS LINE #47	8	24.3	24.1	25.4	32.3	32.1	33.4	10,0	50,0		
1915	RCS LINE #47	8	26.7	26.5	27.7	34.7	34.5	35.7	10,0	50,0		
1916	RCS LINE #47	8	36.6	36.5	37.2	44.6	44.5	45.2	10,0	50,0		
1917	RCS LINE #47	8	27.5	27.4	28.1	35.5	35.4	36.1	10,0	50,0		
1918	RCS LINE #47	8	26.4	26.4	27.5	34.4	34.4	35.5	10,0	50,0		
1919	RCS LINE #47	8	22.2	22.2	24.4	30.2	30.2	32.4	10,0	50,0		
1920	RCS LINE #47	8	19.4	19.5	22.1	27.4	27.5	30.1	10,0	50,0		
1921	RCS LINE #47	8	22.2	22.3	22.2	30.2	30.3	30.2	10,0	50,0		
1951	RCS LINE #47	8	31.1	31.0	31.7	39.1	39.0	39.7	10,0	50,0		
1952	RCS LINE #47	8	31.1	31.1	31.7	39.1	39.1	39.7	10,0	50,0		
1922	RCS LINE #48	8	24.4	26.0	25.5	32.4	34.0	33.5	10,0	50,0		
1923	RCS LINE #48	8	24.4	26.0	25.5	32.4	34.0	33.5	10,0	50,0		
1924	RCS LINE #48	8	24.4	26.0	25.5	32.4	34.0	33.5	10,0	50,0		
1925	RCS LINE #48	8	24.4	26.0	25.5	32.4	34.0	33.5	10,0	50,0		
1926	RCS LINE #48	8	24.4	26.0	25.5	32.4	34.0	33.5	10,0	50,0		
1927	RCS LINE #48	8	23.2	24.1	23.6	31.2	32.1	31.6	10,0	50,0		
1928	RCS LINE #48	8	23.2	24.1	23.6	31.2	32.1	31.6	10,0	50,0		
1929	RCS LINE #48	8	23.2	24.1	23.6	31.2	32.1	31.6	10,0	50,0		
1930	RCS LINE #48	8	26.1	26.9	26.5	34.1	34.9	34.5	10,0	50,0		
1931	RCS LINE #48	8	26.3	28.0	27.4	34.3	36.0	35.4	10,0	50,0		
1932	RCS LINE #48	8	24.2	25.9	25.3	32.2	33.9	33.3	10,0	50,0		
1933	RCS LINE #48	8	24.2	25.9	25.3	32.2	33.9	33.3	10,0	50,0		

Controlled Distribution

REFERENCE : H-P-RP-AI-0040

DATE : 29/SEP/06

ISSUE : 06

Page : 252/405



NODE	LABEL	UFP	Red_1 STR Min	Red_2 REBA Min	Red_3 TT&C Min	Red 82_1 STR1 & 2 Tmax+UFP	Red 82_2 REBA2 DPU2 Tmax+UFP	Red 82_3 TT&C2 Tmax+UFP	TEMPERATURE LIMIT			
									MIN	MAX	MIN	MAX
									OPER.	OPER.	N.OPER.	N.OPER.
1934	RCS LINE #48	8	25.1	25.5	25.3	33.1	33.5	33.3	10,0	50,0		
1935	RCS LINE #48	8	22.5	23.3	22.9	30.5	31.3	30.9	10,0	50,0		
1936	RCS LINE #48	8	22.8	23.5	23.2	30.8	31.5	31.2	10,0	50,0		
1937	RCS LINE #48	8	23.0	23.8	23.5	31.0	31.8	31.5	10,0	50,0		
1938	RCS LINE #48	8	23.5	24.4	24.1	31.5	32.4	32.1	10,0	50,0		
1939	RCS LINE #48	8	22.3	22.8	22.4	30.3	30.8	30.4	10,0	50,0		
1940	RCS LINE #48	8	22.1	22.2	22.0	30.1	30.2	30.0	10,0	50,0		
1941	RCS LINE #48	8	20.1	20.1	20.1	28.1	28.1	28.1	10,0	50,0		
1942	RCS LINE #48	8	19.6	19.5	19.6	27.6	27.5	27.6	10,0	50,0		
1943	RCS LINE #48	8	19.3	19.6	19.6	27.3	27.6	27.6	10,0	50,0		
1944	RCS LINE #48	8	22.8	22.8	22.7	30.8	30.8	30.7	10,0	50,0		
1945	RCS LINE #48	8	32.1	31.5	31.7	40.1	39.5	39.7	10,0	50,0		
1946	RCS LINE #48	8	44.8	43.2	43.8	52.8	51.2	51.8	10,0	50,0		
1947	RCS LINE #48	8	22.3	24.2	24.3	30.3	32.2	32.3	10,0	50,0		
8001	SA EXT -X/ext part	8	117.8	117.8	117.8	125.8	125.8	125.8				
8002	SA EXT -X/ext part	8	118.7	118.7	118.7	126.7	126.7	126.7				
8003	SA EXT -X/ext part	8	117.7	117.7	117.7	125.7	125.7	125.7				
8004	SA EXT -X/ext part	7,5	117.2	117.2	117.2	124.7	124.7	124.7				
8005	SA EXT -X/ext part	7,5	117.6	117.6	117.6	125.1	125.1	125.1				
8006	SA EXT -X/ext part	7,5	117.7	117.7	117.7	125.2	125.2	125.2				
8007	SA EXT -X/ext part	8,4	117.3	117.3	117.3	125.7	125.7	125.7				
8008	SA EXT -X/ext part	8,4	117.6	117.6	117.6	126.0	126.0	126.0				
8009	SA EXT -X/ext part	8,4	117.6	117.6	117.6	126.0	126.0	126.0				

Controlled Distribution

REFERENCE : H-P-RP-AI-0040

DATE : 29/SEP/06

ISSUE : 06

Page : 253/405



NODE	LABEL	UFP	Red_1 STR Min	Red_2 REBA Min	Red_3 TT&C Min	Red 82_1 STR1 & 2 Tmax+UFP	Red 82_2 REBA2 DPU2 Tmax+UFP	Red 82_3 TT&C2 Tmax+UFP	TEMPERATURE LIMIT			
									MIN	MAX	MIN	MAX
									OPER.	OPER.	N.OPER.	N.OPER.
8010	SA EXT -X/ext part	8,1	115.7	115.7	115.8	123.8	123.8	123.9				
8011	SA EXT -X/ext part	8,1	117.8	117.8	117.8	125.9	125.9	125.9				
8012	SA EXT -X/ext part	8,1	117.6	117.6	117.6	125.7	125.7	125.7				
8051	SA EXT +X/ext part	8	117.4	117.4	117.4	125.4	125.4	125.4				
8052	SA EXT +X/ext part	8	118.3	118.3	118.3	126.3	126.3	126.3				
8053	SA EXT +X/ext part	8	117.4	117.4	117.4	125.4	125.4	125.4				
8054	SA EXT +X/ext part	7,6	116.8	116.8	116.8	124.4	124.4	124.4				
8055	SA EXT +X/ext part	7,6	117.3	117.3	117.3	124.9	124.9	124.9				
8056	SA EXT +X/ext part	7,6	117.4	117.4	117.4	125.0	125.0	125.0				
8057	SA EXT +X/ext part	8,4	116.8	116.8	116.8	125.2	125.2	125.2				
8058	SA EXT +X/ext part	8,4	117.3	117.3	117.3	125.7	125.7	125.7				
8059	SA EXT +X/ext part	8,4	117.3	117.3	117.3	125.7	125.7	125.7				
8060	SA EXT +X/ext part	8,1	115.3	115.3	115.4	123.4	123.4	123.5				
8061	SA EXT +X/ext part	8,1	117.5	117.5	117.5	125.6	125.6	125.6				
8062	SA EXT +X/ext part	8,1	117.3	117.3	117.3	125.4	125.4	125.4				
8171	SA EXT +X/int part	8	119.2	119.2	119.2	127.2	127.2	127.2				
8172	SA EXT +X/int part	8	116.8	116.8	116.8	124.8	124.8	124.8				
8173	SA EXT +X/int part	8	118.6	118.6	118.6	126.6	126.6	126.6				
8174	SA EXT +X/int part	7,6	118.8	118.8	118.8	126.4	126.4	126.4				
8175	SA EXT +X/int part	7,6	118.6	118.6	118.6	126.2	126.2	126.2				
8176	SA EXT +X/int part	7,6	119.1	119.1	119.1	126.7	126.7	126.7				
8177	SA EXT +X/int part	8,4	119.0	119.0	119.0	127.4	127.4	127.4				
8178	SA EXT +X/int part	8,4	118.7	118.7	118.7	127.1	127.1	127.1				

Controlled Distribution

REFERENCE : H-P-RP-AI-0040

DATE : 29/SEP/06

ISSUE : 06

Page : 254/405



NODE	LABEL	UFP	Red_1 STR Min	Red_2 REBA Min	Red_3 TT&C Min	Red 82_1 STR1 & 2 Tmax+UFP	Red 82_2 REBA2 DPU2 Tmax+UFP	Red 82_3 TT&C2 Tmax+UFP	TEMPERATURE LIMIT			
									MIN	MAX	MIN	MAX
									OPER.	OPER.	N.OPER.	N.OPER.
8179	SA EXT +X/int part	8,4	118.0	118.0	118.0	126.4	126.4	126.4				
8180	SA EXT +X/int part	8,1	119.8	119.8	119.8	127.9	127.9	127.9				
8181	SA EXT +X/int part	8,1	117.8	117.8	117.8	125.9	125.9	125.9				
8182	SA EXT +X/int part	8,1	119.7	119.7	119.7	127.8	127.8	127.8				
8301	Central Solar Array -X	7,9	127.1	127.1	127.1	135.0	135.0	135.0				
8302	Central Solar Array -X	7,9	125.7	125.7	125.7	133.6	133.6	133.6				
8303	Central Solar Array -X	7,9	125.4	125.4	125.4	133.3	133.3	133.3				
8304	Central Solar Array -X	8	125.3	125.3	125.3	133.3	133.3	133.3				
8305	Central Solar Array -X	8	125.3	125.3	125.3	133.3	133.3	133.3				
8306	Central Solar Array -X	8	125.4	125.4	125.4	133.4	133.4	133.4				
8307	Central Solar Array -X	8,1	125.3	125.3	125.3	133.4	133.4	133.4				
8308	Central Solar Array -X	8,1	125.3	125.3	125.3	133.4	133.4	133.4				
8309	Central Solar Array -X	8,1	125.5	125.5	125.5	133.6	133.6	133.6				
8310	Central Solar Array -X	7,9	125.4	125.4	125.4	133.3	133.3	133.3				
8311	Central Solar Array -X	7,9	125.4	125.4	125.4	133.3	133.3	133.3				
8312	Central Solar Array -X	7,9	125.5	125.5	125.5	133.4	133.4	133.4				
8351	Central Solar Array +X	7,9	126.9	126.8	126.8	134.8	134.7	134.7				
8352	Central Solar Array +X	7,9	125.5	125.5	125.5	133.4	133.4	133.4				
8353	Central Solar Array +X	7,9	125.2	125.2	125.2	133.1	133.1	133.1				
8354	Central Solar Array +X	8	125.1	125.1	125.1	133.1	133.1	133.1				
8355	Central Solar Array +X	8	125.1	125.1	125.1	133.1	133.1	133.1				
8356	Central Solar Array +X	8	125.2	125.2	125.2	133.2	133.2	133.2				
8357	Central Solar Array +X	8,1	125.1	125.1	125.1	133.2	133.2	133.2				

Controlled Distribution

REFERENCE : H-P-RP-AI-0040

DATE : 29/SEP/06

ISSUE : 06

Page : 255/405



NODE	LABEL	UFP	Red_1 STR Min	Red_2 REBA Min	Red_3 TT&C Min	Red 82_1 STR1 & 2 Tmax+UFP	Red 82_2 REBA2 DPU2 Tmax+UFP	Red 82_3 TT&C2 Tmax+UFP	TEMPERATURE LIMIT			
									MIN	MAX	MIN	MAX
									OPER.	OPER.	N.OPER.	N.OPER.
8358	Central Solar Array +X	8,1	125.2	125.2	125.2	133.3	133.3	133.3				
8359	Central Solar Array +X	8,1	125.3	125.3	125.3	133.4	133.4	133.4				
8360	Central Solar Array +X	7,9	125.2	125.2	125.2	133.1	133.1	133.1				
8361	Central Solar Array +X	7,9	125.2	125.2	125.2	133.1	133.1	133.1				
8362	Central Solar Array +X	7,9	125.4	125.4	125.4	133.3	133.3	133.3				

Controlled Distribution



REFERENCE : H-P-RP-AI-0040

DATE : 29/SEP/06

ISSUE : 06

Page : 256/405

8.5.4.4 Heater Power Summary

The following table reports the heater power consumption for the transient nominal analysis cases.

Table 8.5.4.3-1 PLANCK - Heater power need

Line	Description	Installed power [W]	A1 BOL Mode1 [W]	A2 BOL Mode2 [W]	A3 BOL Mode3 [W]	C BOL Surv [W]	B1 EOL SCC1 on [W]	B2 EOL8 SCC2 on [W]
24	1FCV BODY	2,35	0	0	0	1,24	0	0
38	1FCV BODY	2,35	0.83	0.99	0.86	1,28	0.35	0.34
25	1FCV BODY	2,35	0	0	0	0,34	0	0
39	1FCV BODY	2,35	0	0.15	0	0,34	0	0
26	FCV BODY MAIN	1,43	0	0	0	0	0	0
40	FCV BODY RED	1,43	0	0	0	0	0	0
27	FCV BODY MAIN	1,43	0	0	0	0	0	0
41	FCV BODY RED	1,43	0	0	0	0	0	0
28	FCV BODY MAIN	1,43	0	0	0	0	0	0
42	FCV BODY RED	1,43	0	0	0	0	0	0
29	FCV BODY MAIN	1,43	0	0	0	0	0	0
43	FCV BODY RED	1,43	0	0	0	0	0	0
30	FCV BODY MAIN	1,43	0	0.08	0	0	0	0
44	FCV BODY RED	1,43	0	0.17	0.12	1,04	0	0
31	FCV BODY MAIN	1,43	0.67	0.73	0.7	0	0.43	0.44
45	FCV BODY RED	1,43	0.61	0.67	0.64	0,13	0,37	0,37
1	STR_MY -X FOOT	4,7	0	0	0	0	0	0
2	STR_PY -X FOOT	4,7	0	0	0	0	0	0
3	DPU1	22,78	0	0	0	7,78	0	0
4	DPU2	22,78	0	0	0	17,99	0	0
36	REBA2	34,17	0	0	0	34,17	0	0
35	4K CAU	38,98	0	0	0	38,98	0	0
16	4K CRU EX 4K PRE-REG	12,8	0	0	12,8	0	0	0
6	4K CCU I/F Bckt +X	51,92	0	0	0	52,5	0	0
5	REU	62,04	0	0	0	46,14	0	0
15	PAU	8,1	0	0	0	4,57	0	0
37	BATTERY	14,9	0	0	0	0	0	0
14	Helium Tank	3,08	0	0	0	0	0	0
21	Prop.Tank+Y+Z Low	6,17	0,77	0,77	0,77	1,3	0,77	0,77
22	Prop.Tank -Z Lower	6,17	0,77	0,77	0,77	1,08	0,77	0,77
23	Prop.Tank -Y+Z Low	6,17	0,77	0,77	0,77	0,77	0,77	0,77

Controlled Distribution



REFERENCE : H-P-RP-AI-0040

DATE : 29/SEP/06

ISSUE : 06

Page : 257/405

Line	Description	Installed power [W]	A1 BOL Mode1 [W]	A2 BOL Mode2 [W]	A3 BOL Mode3 [W]	C BOL Surv [W]	B1 EOL SCC1 on [W]	B2 EOL8 SCC2 on [W]
17	CRS1	24,3	16.9	18.13	17.41	19.19	13.08	13.09
18	CRS2	24,3	16.66	17.71	17.1	18.21	12.95	12.99
19	CRS3	24,3	20.86	22	21.38	15.91	17.27	17.18
7	SCC / SCE H P	78	78	78	78	78	0.65	9.63
8	SCC / SCE H P	78	78	78	78	78	0	0
9	SCC / SCE H P	91	29	32.09	30.53	91	0	0
10	SCC / SCE H P	91	0	0	0	91	0	0
11	SCC / SCE H P	91	0	0	0	91	0	0
12	SCC / SCE H P	91	0	0	0	91	0	0
13	SCC / SCE H P	91	0	0	0	11.8	0	0
32	RCS LINE 32	4,9	1	1.25	1.14	2.91	0.27	0.27
33	RCS LINE 33	3,79	1.87	2.52	2.18	3.79	0.43	0.42
34	RCS LINE 34	4,87	2.84	3.51	3.13	4.87	1.04	1.03
46	RCS LINE 46	11,72	5.04	5.24	5.12	6.02	3.86	3.97
47	RCS LINE 47	8,45	6.13	7.02	6.53	8.16	4.01	3.33
48	RCS LINE 48	6,37	1.76	2.34	2.08	4.02	0.11	0.11
	TOTAL [W]	1050,02	262.48	272.91	280.03	824.53	57.13	65,48

Controlled Distribution

8.5.4.5 Sun trapping on Solar Array

The effect of the sun trapping into the gap among the solar array panels of PLANCK, has been analyzed using a dedicated reduced model and considering the gap as a cavity.

The lateral sides of the cavity (solar array edge) have been assumed covered by black kapton tape, and the bottom of the cavity is a black kapton foil (see figure).

In this condition, considering the sun perpendicular to the cavity ($SAA=0^\circ$) and in winter solstice (solar constant of 1405 W/m^2) and assuming adiabatic condition (i.e. no flux exchange to the other surfaces), the following temperature are obtained:

- Lateral sides: 106°C
- Bottom side: 181°C

The 181°C maximum temperature is reached only by the bottom kapton foil and it has to be considered as a hot spot. While on the solar array lateral side the temperature of 106°C will not be exceeded.

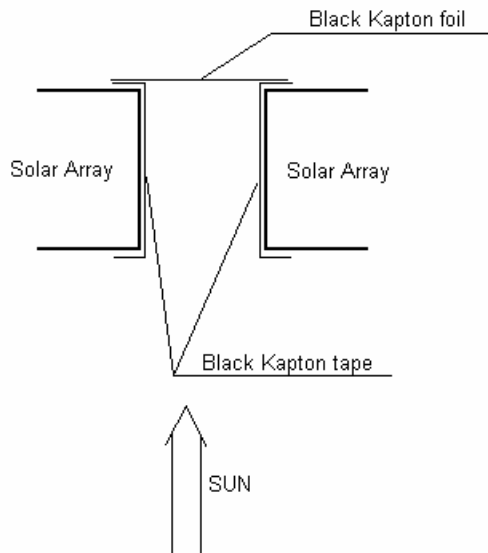

Figure 8.5.4.5-1 PLANCK – Sun trapping

9 CONCLUSIONS

9.1 HERSCHEL

The following thermal interface requirements are not compliant (NC) or partially compliant (PC) with respect to the applicable requirements and are treated by dedicated RFD:

- **ITP-100-H : NC**

In the previous issue (issue 4.0) of this document the out of spec was -43.2°C vs -53°C of requirement. This out of specification was approved by AAS-F (for details see applicable RFD (H-P-300000-ALS-RD-0009, Issue 2 and CCB#72, H-P-ASP-LT-5490)) with no design modification.

The present value calculated by analysis is -35.5°C and this worst value is due to the updated PLM temperature interfaces (see AD20) provided by AAS-F (see H-P-ASPI-CR-0707). No design modification are envisaged to recovery this out of specification.

- **ITP-120-H : PC and ITP-130-H : PC**

For details see applicable RFD (H-P-300000-ALS-RD-0029, Issue 1) issued by ALS and approved by ASP (see CCB#69, H-P-ASP-MN-5329) with no design modification.

After the TMM updating, the radiative area has been optimised with the objective to decrease the overall heater power consumption. As a consequence the satellite average temperature is increased and the requirement on the truss and shield attachment points can not completely met. This requirement could be satisfied decreasing again the average temperature of satellite, but with an important impact on power budget

Due to the limited average out of specification (25.9°C vs 20°C and 23.1°C vs 20°C) it is suggested to maintain the current design to avoid impact on the power budget.

Controlled Distribution



REFERENCE : H-P-RP-AI-0040

DATE : 29/SEP/06

ISSUE : 06

Page : 260/405

All the units are maintained within their temperature limits with the exclusion of the following:

HOT CASES (Uncertainty included)

- | | | |
|--|-----------|----------------------|
| <input type="checkbox"/> <u>TWT:</u> | all cases | max 74.8°C vs 60.0°C |
| <input type="checkbox"/> <u>TRANSX:</u> | all cases | max 53.5°C vs 50°C |

REMARK: A general increase of the +Z, +Z+Y and +Z-Y Panels temperature is due to the updated Boundary temperatures of the PLM Model. The updated temperatures of the MLI faced to the SVM are 20°C higher than before and in particular for what concern the MLI with a view factor to the radiators of TTC panel the increase is of 35°C. This leads to an increase of the TTC and TRANSX that were yet critical before.

Some out of spec are detected on the RCS nodes directly behind the Thruster on +Z, the SAS on +Z and the Thruster on +Y:

- | | | |
|--|--------|------------------|
| <input type="checkbox"/> <u>RCS #9 point on THRUSTER+Z(*):</u> | case B | 54.8°C vs 50.0°C |
| <input type="checkbox"/> <u>RCS #9 point on SAS+Z(*):</u> | case B | 52.7°C vs 50.0°C |
| <input type="checkbox"/> <u>RCS #47 point on THRUSTER+Y(*):</u> | case E | 50.9°C vs 50.0°C |

Remarks*:

RCS Line out of specification will be covered by a dedicated RFD. An assessment made by EADS for a max T equal to 54.8°C shows that no problem are envisaged

RECOVERY ACTIONS:

TWT:

A preliminary assessment has been done taking into account the local analysis.

In the Thales TWT thermal analysis (40 63 362 issue 1 rev B) the baseplate thermal reference point can sustain 70°C with a maximum housing temperature of 82.7°C. The main temperature limitation is 175°C then a safety margin is present even with a baseplate thermal reference point at 74.8°C. No design modifications are envisaged. Dedicated RFD (H-P-300000-ALS-RD-0040, Issue 1) has been issued by TCS, and approved by AAS-I at system level, for the previous TWT temperature value equal to 71.1°C. No design modifications are envisaged.

This temperature increase (74.8°C vs 71.1°C) compared with the previous issue is mainly due to two contribution:

1. PLM Boundary temperature interfaces (MLI) updating as reported in AD20 (about 2.7°C)
2. CRS always maintained at the maximum temperature (about 1°C)

Moreover it has to be noted that using the redundant line for the TT&C units, all the out of specification on TWT and TRANSX will be avoided. The redundant units are mounted on the lower part of the +Z+Y Panel and then:

- The available radiative area is bigger
- The view factor to the PLM MLI closure is negligible

TRANSX:

Same considerations (PLM Boundary temperature interfaces (MLI) updating as reported in AD20 (about 2.5°C) and CRS always maintained at the maximum temperature (about 1.5°C)) and same recovery action proposed before for TWT are applicable also for Transponder

Controlled Distribution



REFERENCE : H-P-RP-AI-0040

DATE : 29/SEP/06

ISSUE : 06

Page : 261/405

RCS:

Due to the limited number of out of specification and taken into account that this happen only at the end of life, AAS-I proposes to maintain the present design without any design modifications.

COLD CASES (Uncertainty included)

A limited out of spec is present on some RCS nodes on the line 37 only in the **SURVIVAL CASE**. It has to be noted that the 8°C uncertainty has been always applied on the RCS nodes even if they are actively controlled by heaters.

Controlled Distribution



REFERENCE : H-P-RP-AI-0040

DATE : 29/SEP/06

ISSUE : 06

Page : 262/405

9.2 PLANCK

The following thermal interface requirements are not compliant (NC) or partially compliant (PC) with respect to the applicable requirements and are treated by dedicated RFD:

- **ITP-150-P: NC**
In the previous issue (issue 5.0) of this document the out of spec was -41.7°C vs -53°C of requirement. This out of specification was approved by AAS-F (for details see applicable RFD (H-P-300000-ALS-RD-0009, Issue 2 and CCB#72, H-P-ASP-LT-5490)) with no design modification.
The present value calculated by analysis is within the requirement of -53°C but applying 23°C of uncertainty the obtained value is out of specification (-30.2°C).
No design modification are envisaged to recovery this out of specification
- **ITP-170-P: NC**
The maximum radiative flux between BEU/PAU radiators and PLM shield is 3.29 W if calculated without the uncertainty temperature. Considering the uncertainty temperature, as requested by ASP, the radiative flux is of 3.76 W vs maximum radiative load of 2.3 W.
In the previous issue (issue 5.0) of this document the out of spec was -2.41°C and this out of specification was approved by AAS-F (for details see applicable RFD (H-P-300000-ALS-RD-0010, Issue 3) with no design modification.
- **ITP-200-P: NC**
Already covered by RFD (H-P-300000-ALS-RD-0009, Issue 2) issued by ALS and approved by ASP (see CCB#72, H-P-ASP-LT-5490) with no design modification.
- **SCC Stability (Absorbing beds stability): NC**
Already covered by RFD (H-P-300000-ALS-RD-0013, Issue 4) issued by ALS and approved by ASP (see CCB#74, H-P-ASP-MN-5553).

Controlled Distribution



REFERENCE : H-P-RP-AI-0040

DATE : 29/SEP/06

ISSUE : 06

Page : 263/405

All the units are maintained within their temperature limits with the exclusion of the following:

HOT CASES (Uncertainty included)

- | | | | |
|---|------------|-------|------------------|
| <input type="checkbox"/> <u>RCS Line #46(*)</u> : | case B1&B2 | T max | 54.6°C vs 50.0°C |
| <input type="checkbox"/> <u>RCS Line #47(*)</u> : | case B1&B2 | T max | 53.3°C vs 50.0°C |
| <input type="checkbox"/> <u>RCS Line #48(*)</u> : | case B1&B2 | T max | 52.6°C vs 50.0°C |

Remarks*:

RCS Line out of specification will be covered by a dedicated RFD. An assessment made by EADS for a max T equal to 54.8°C shows that no problem are envisaged

COLD CASES (Uncertainty included)

- | | | |
|---|---------|-----------------|
| <input type="checkbox"/> <u>FOG (ICU)**</u> | case A2 | -0.4°C vs 0.0°C |
| | case A3 | -2.9°C vs 0.0°C |

Remarks**:

These results are obtained using new inputs provided by ESA (SCI-PT/33615, dated 02/02/05) that foreseen 3 channels switched-ON (16.5 watts dissipated).

The temperature (including uncertainty) reached by FOG (ICU) in Cold case A2 & A3 is below the minimum operative limit of 0°C. In this case it is possible raise the temperature above 0°C switching on at 100% the 4K CRU's heaters (12.8 W) mounted on the same shear panel.

Controlled Distribution



REFERENCE : H-P-RP-AI-0040

DATE : 29/SEP/06

ISSUE : 06

Page : 264/405

10 HERSCHEL: TEMPERATURE PLOTS

10.1 HERSCHEL RESULTS OF CASE B

HERSCHEL HOT CASE B EOL

PANEL +Y+Z

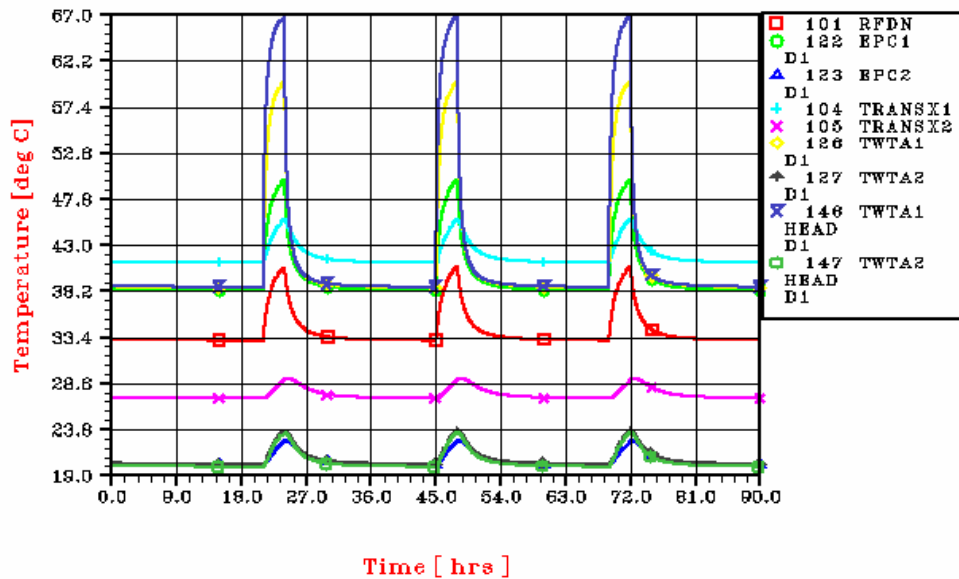

HERSCHEL HOT CASE B EOL

INTERNAL UNITS

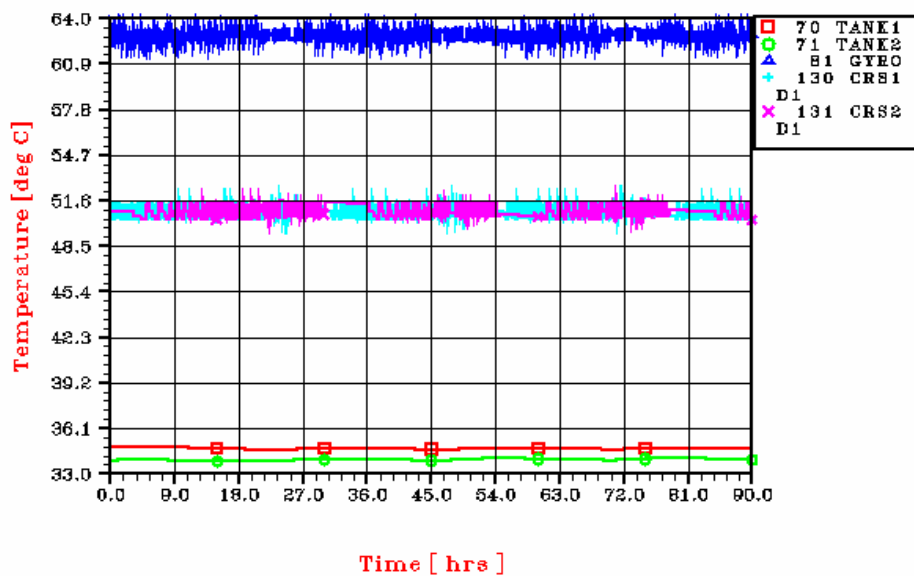

Controlled Distribution



REFERENCE : H-P-RP-AI-0040

DATE : 29/SEP/06

ISSUE : 06

Page : 265/405

HERSCHEL HOT CASE B EOL

PANEL +Y

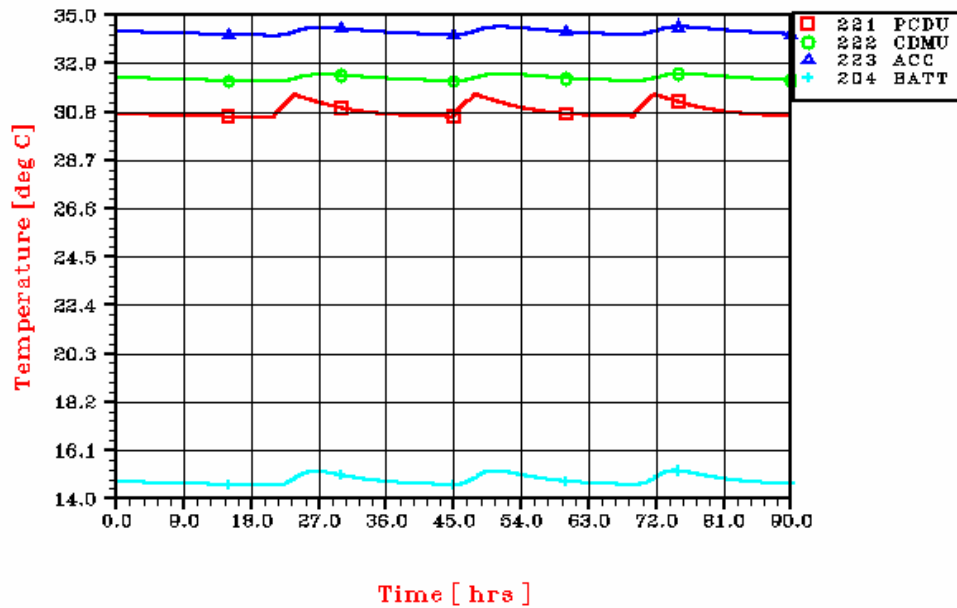

HERSCHEL HOT CASE B EOL

PANEL +Y-Z

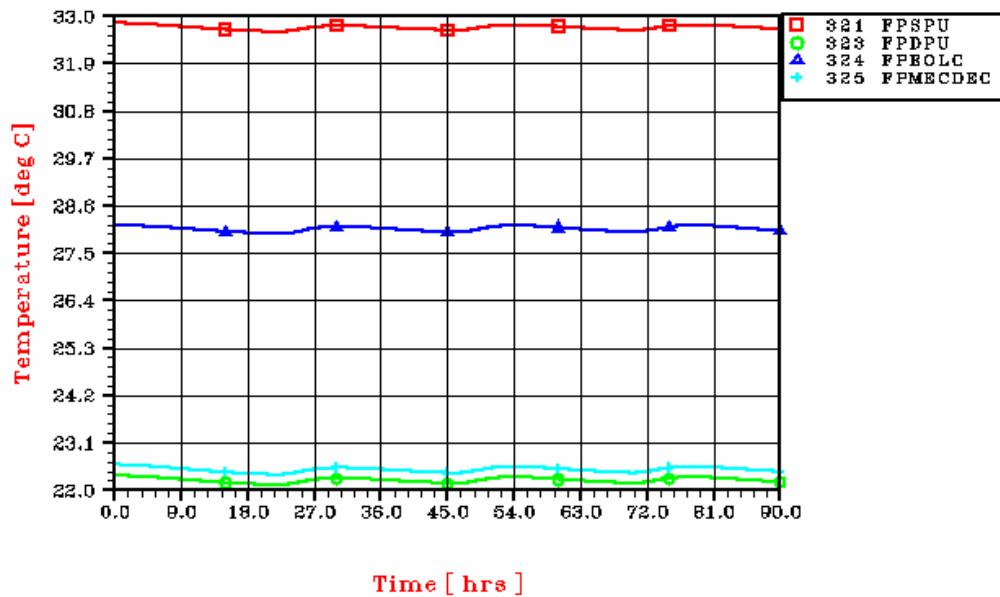

Controlled Distribution



REFERENCE : H-P-RP-AI-0040

DATE : 29/SEP/06

ISSUE : 06

Page : 266/405

HERSCHEL HOT CASE B EOL

PANEL -Z

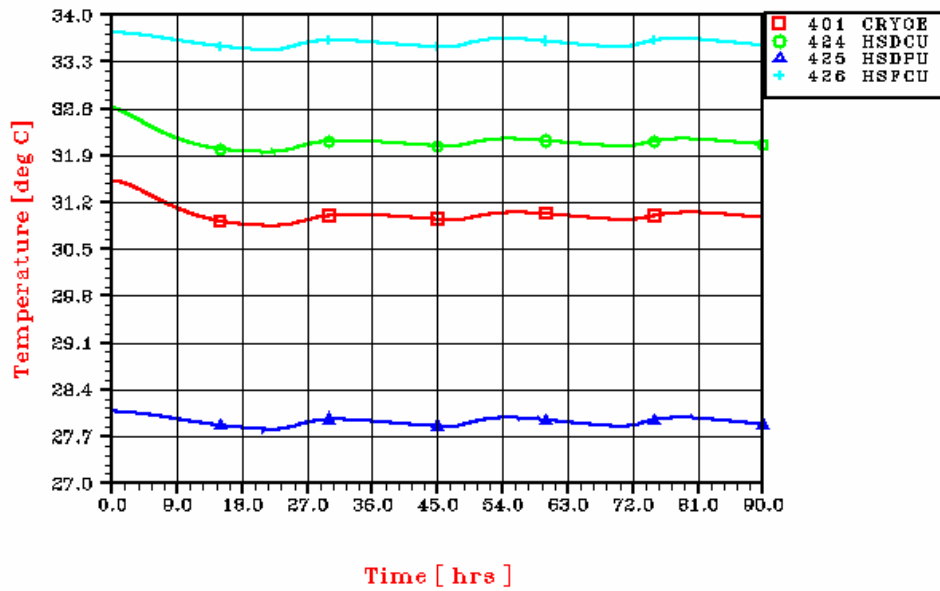

HERSCHEL HOT CASE B EOL

PANEL -Y-Z

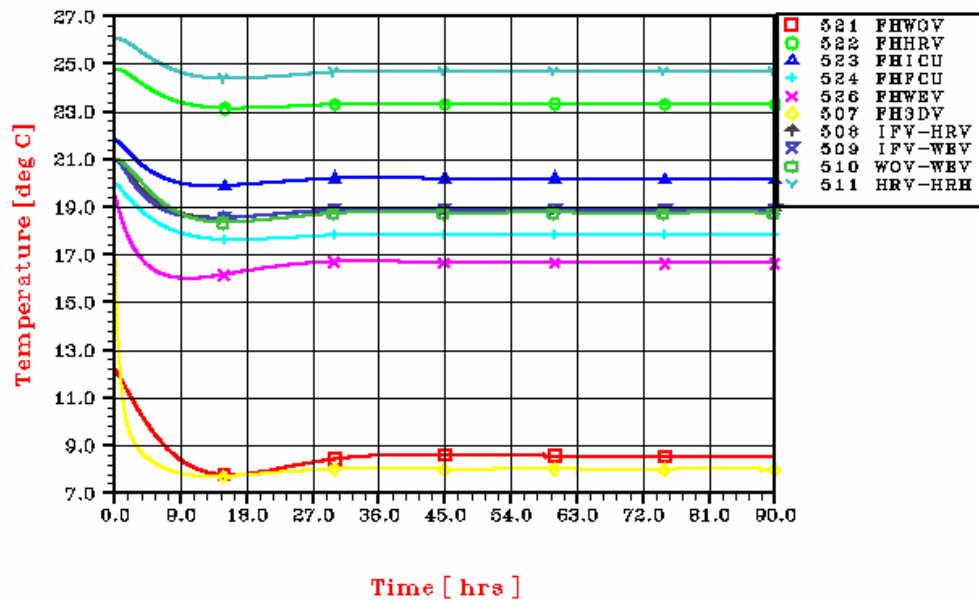

Controlled Distribution

HERSCHEL HOT CASE B EOL

PANEL -Y

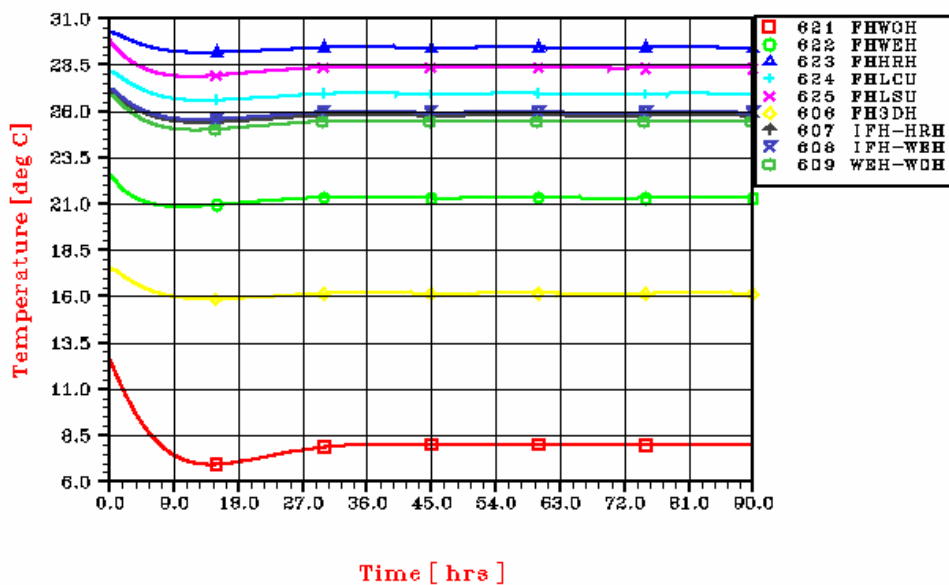

HERSCHEL HOT CASE B EOL

PANEL -Y+Z

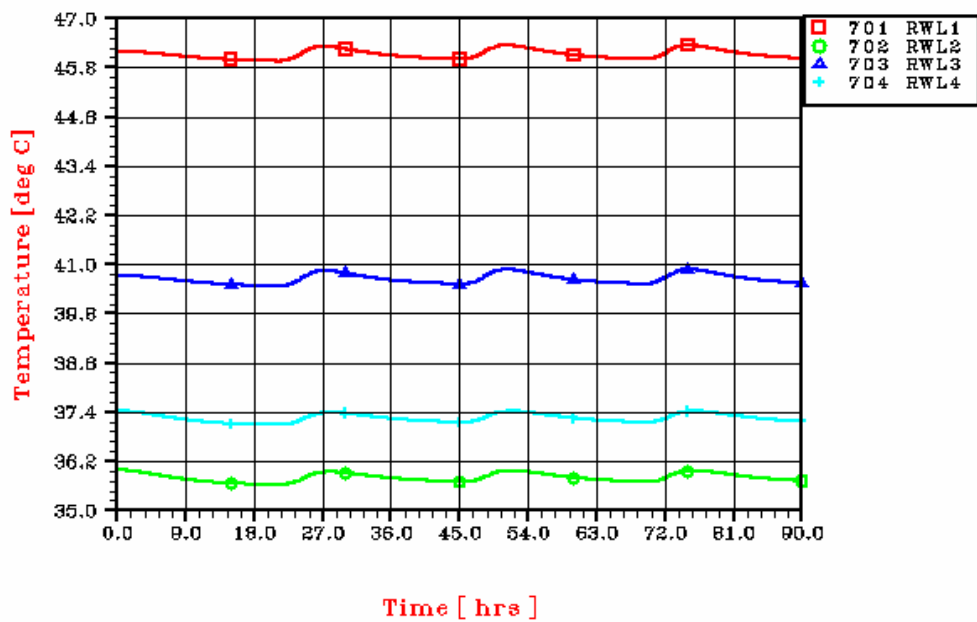

Controlled Distribution



REFERENCE : H-P-RP-AI-0040

DATE : 29/SEP/06

ISSUE : 06

Page : 268/405

HERSCHEL HOT CASE B EOL

EXTERNAL UNITS

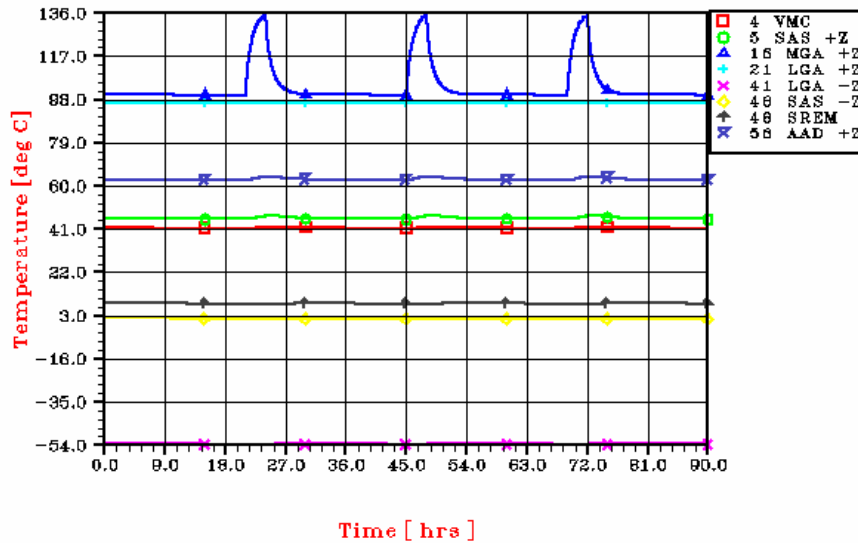

HERSCHEL HOT CASE B EOL

STR

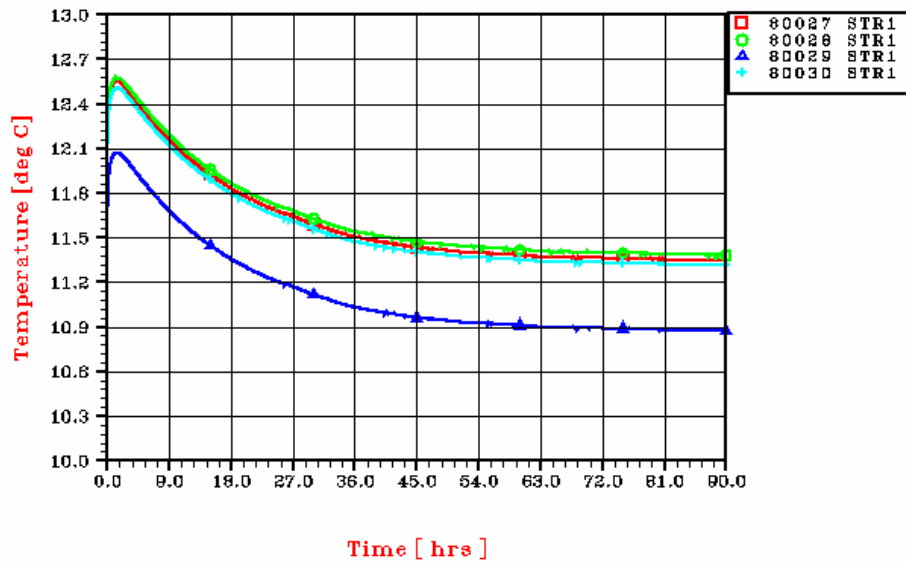

Controlled Distribution



REFERENCE : H-P-RP-AI-0040

DATE : 29/SEP/06

ISSUE : 06

Page : 269/405

HERSCHEL HOT CASE B EOL STR BASEPLATE

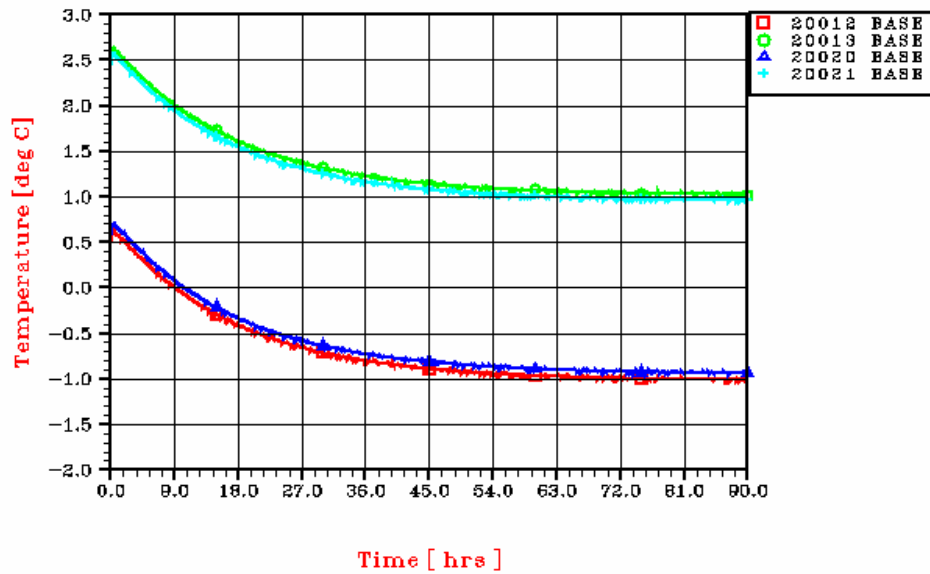

HERSCHEL HOT CASE B EOL STR

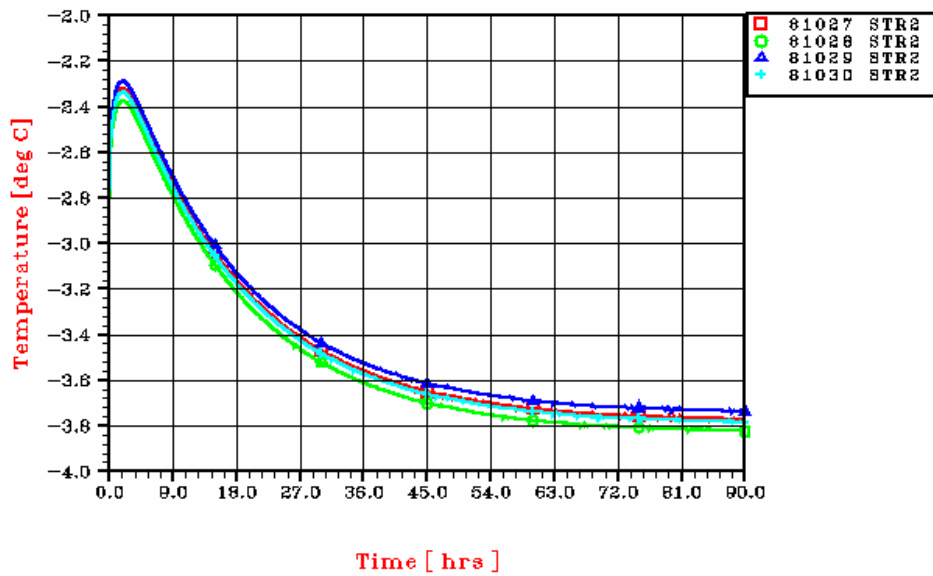

Controlled Distribution



REFERENCE : H-P-RP-AI-0040

DATE : 29/SEP/06

ISSUE : 06

Page : 270/405

HERSCHEL HOT CASE B EOL

THRUSTERS MAIN

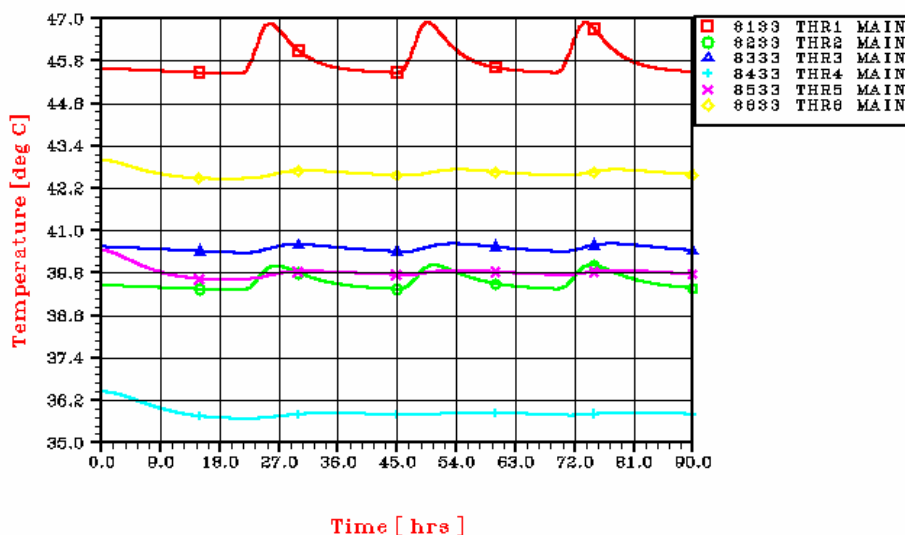

HERSCHEL HOT CASE B EOL

THRUSTERS REDUNDANT

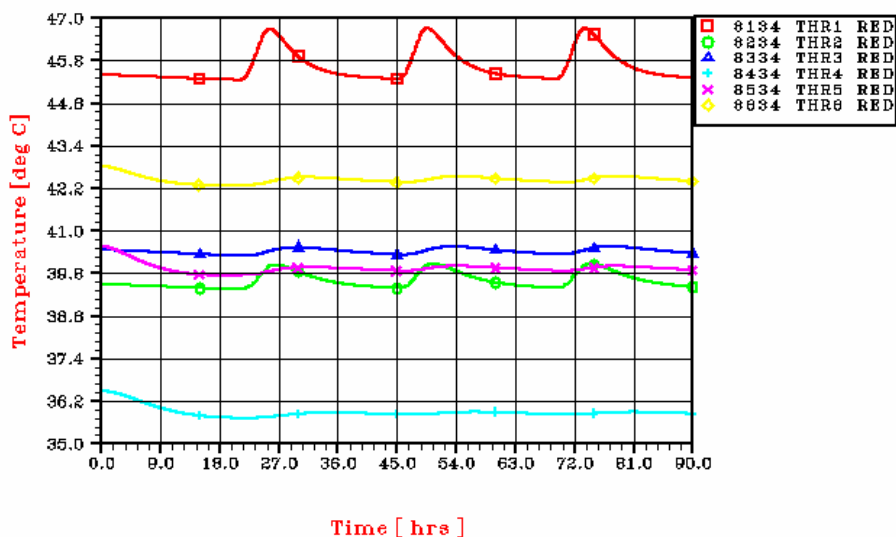

Controlled Distribution

10.2 HERSCHEL RESULTS OF CASE G

HERSCHEL COLD CASE G BOL

PANEL +Y+Z

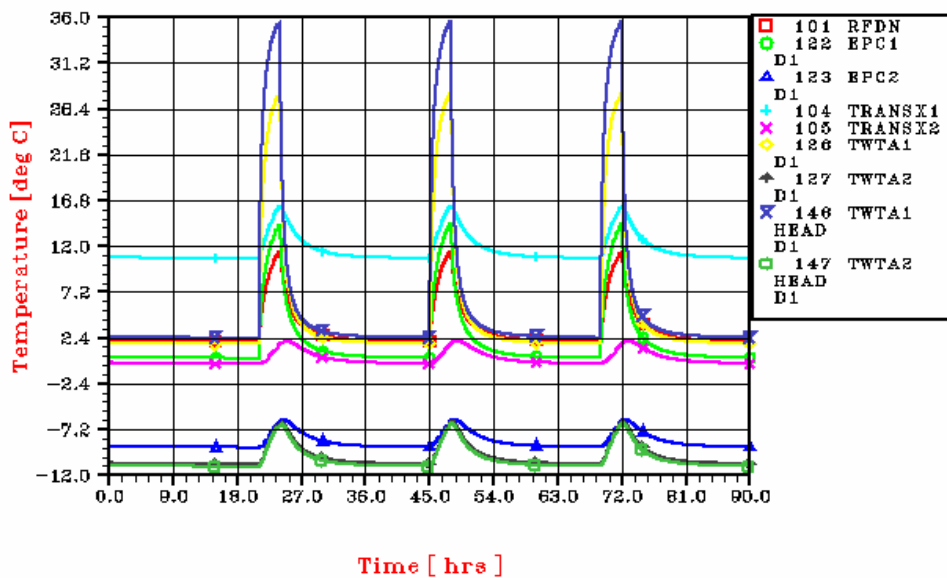

HERSCHEL COLD CASE G BOL

INTERNAL UNITS

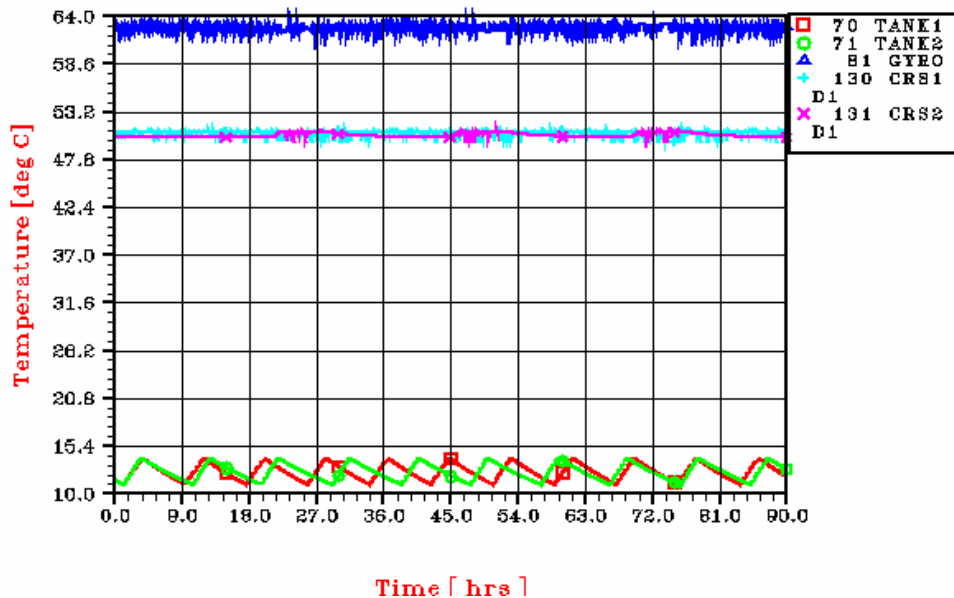

Controlled Distribution



REFERENCE : H-P-RP-AI-0040

DATE : 29/SEP/06

ISSUE : 06

Page : 272/405

HERSCHEL COLD CASE G BOL

PANEL +Y

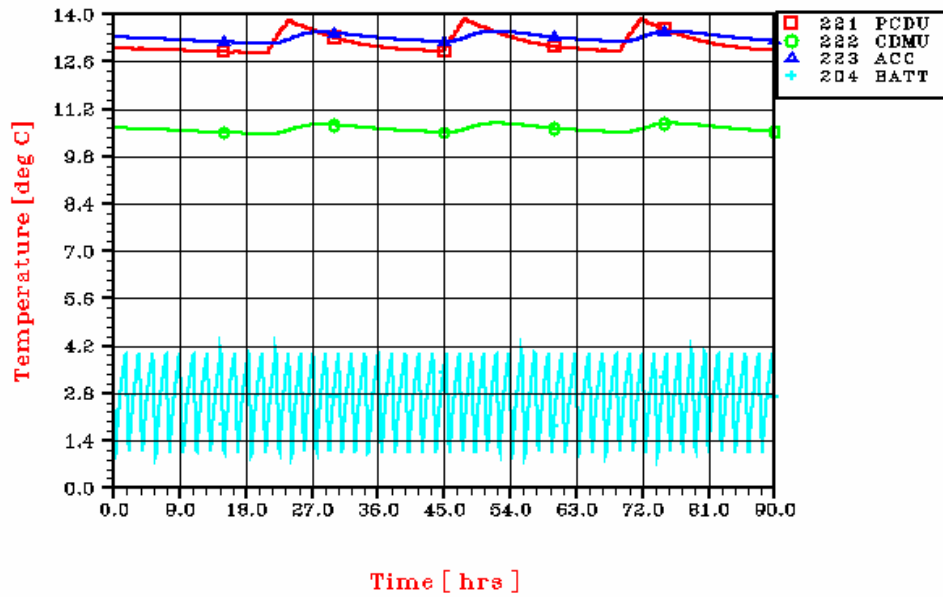

HERSCHEL COLD CASE G BOL

PANEL +Y-Z

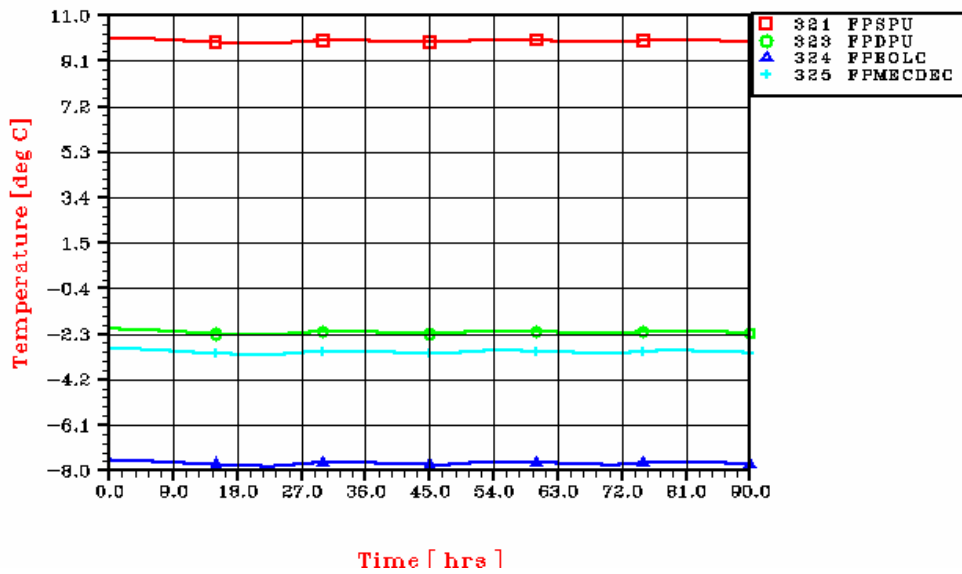

Controlled Distribution



REFERENCE : H-P-RP-AI-0040

DATE : 29/SEP/06

ISSUE : 06

Page : 274/405

HERSCHEL COLD CASE G BOL

PANEL -Y

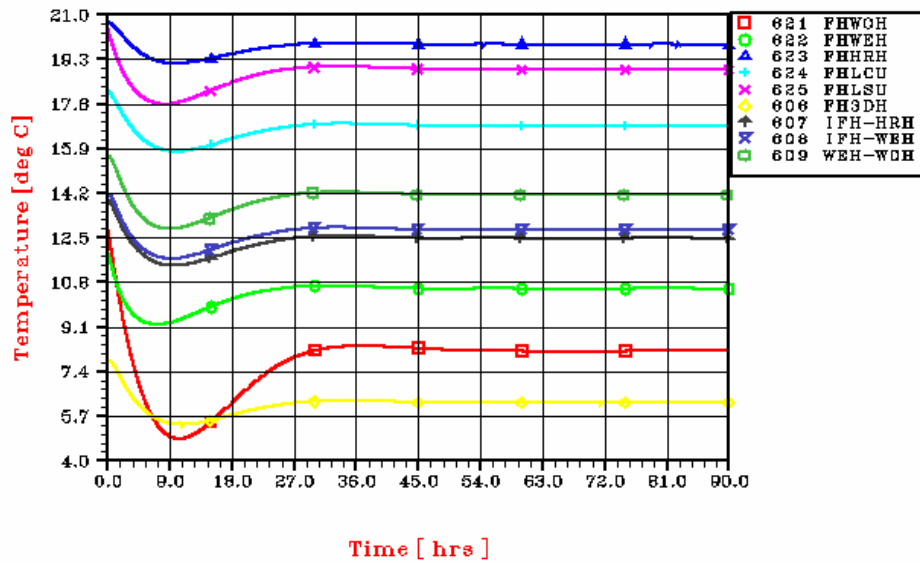

HERSCHEL COLD CASE G BOL

PANEL -Y+Z

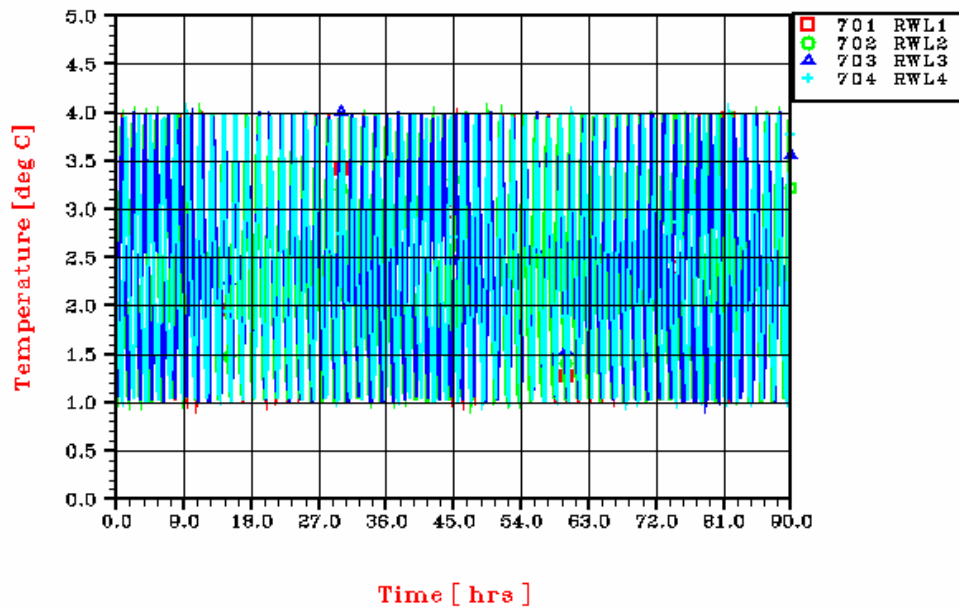

Controlled Distribution



REFERENCE : H-P-RP-AI-0040

DATE : 29/SEP/06

ISSUE : 06

Page : 275/405

HERSCHEL COLD CASE G BOL EXTERNAL UNITS

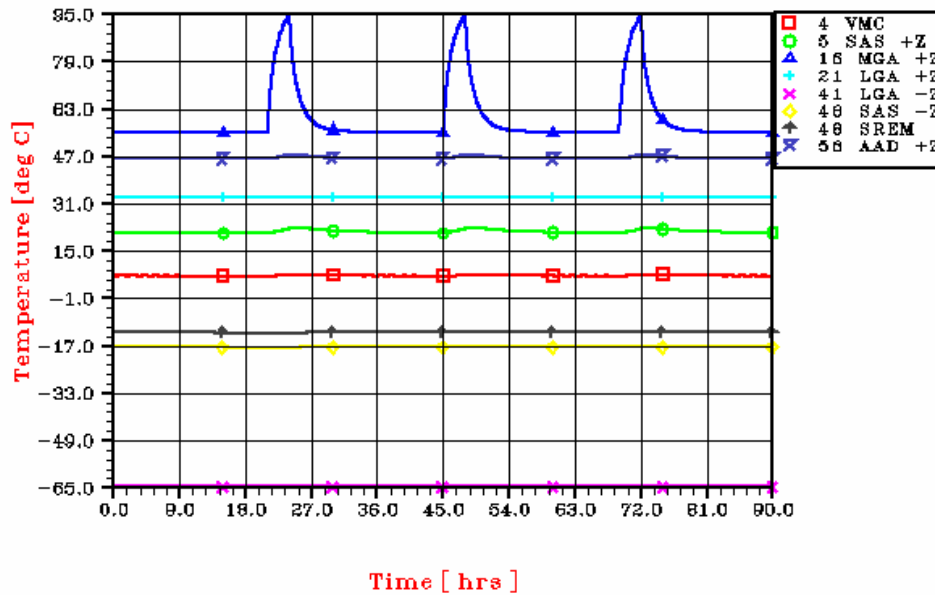

HERSCHEL COLD CASE G BOL STR

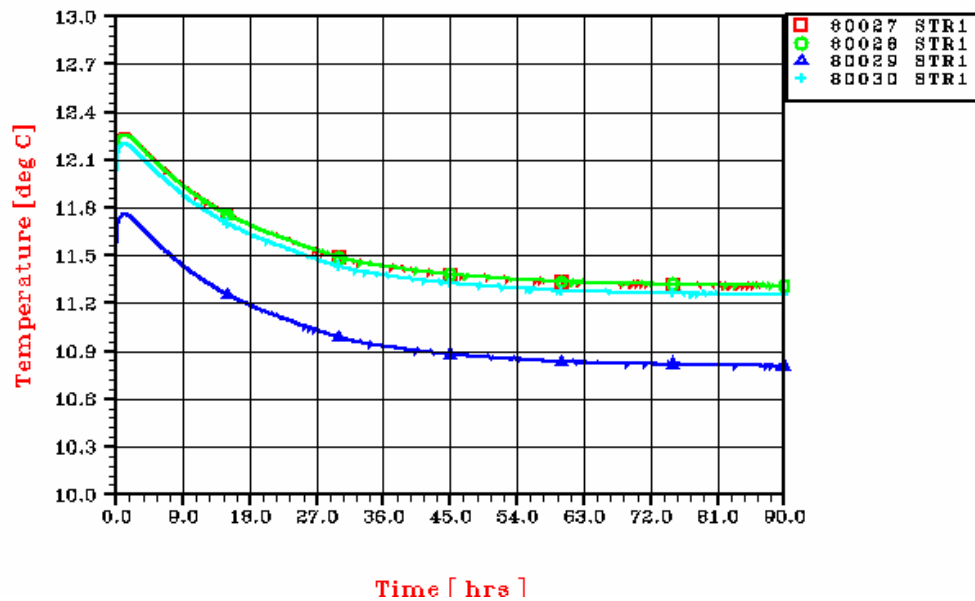

Controlled Distribution



REFERENCE : H-P-RP-AI-0040

DATE : 29/SEP/06

ISSUE : 06

Page : 276/405

HERSCHEL COLD CASE G BOL STR BASEPLATE

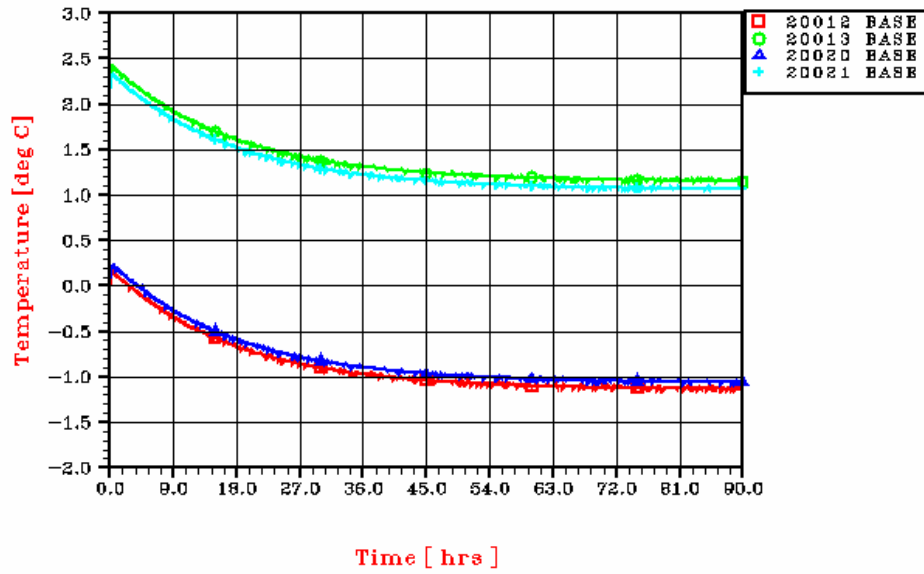

HERSCHEL COLD CASE G BOL STR

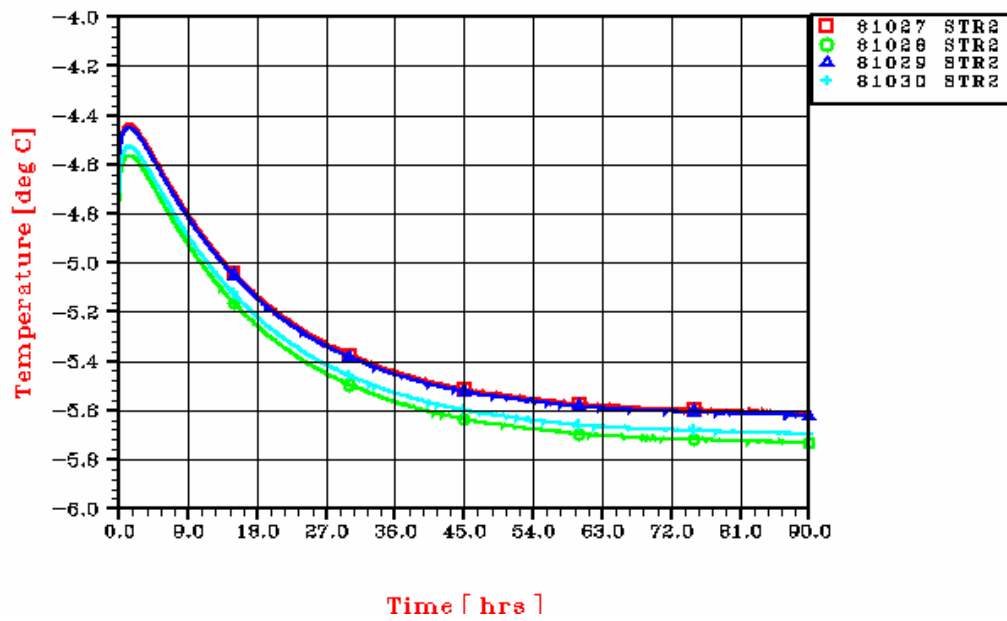

Controlled Distribution



REFERENCE : H-P-RP-AI-0040

DATE : 29/SEP/06

ISSUE : 06

Page : 277/405

HERSCHEL COLD CASE G BOL THRUSTERS MAIN

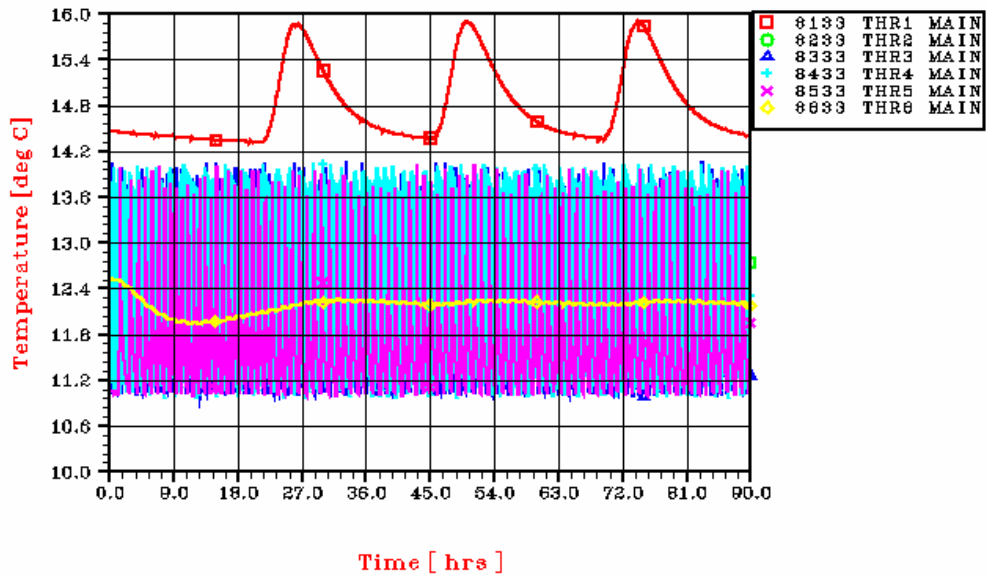

HERSCHEL COLD CASE G BOL THRUSTERS REDUNDANT

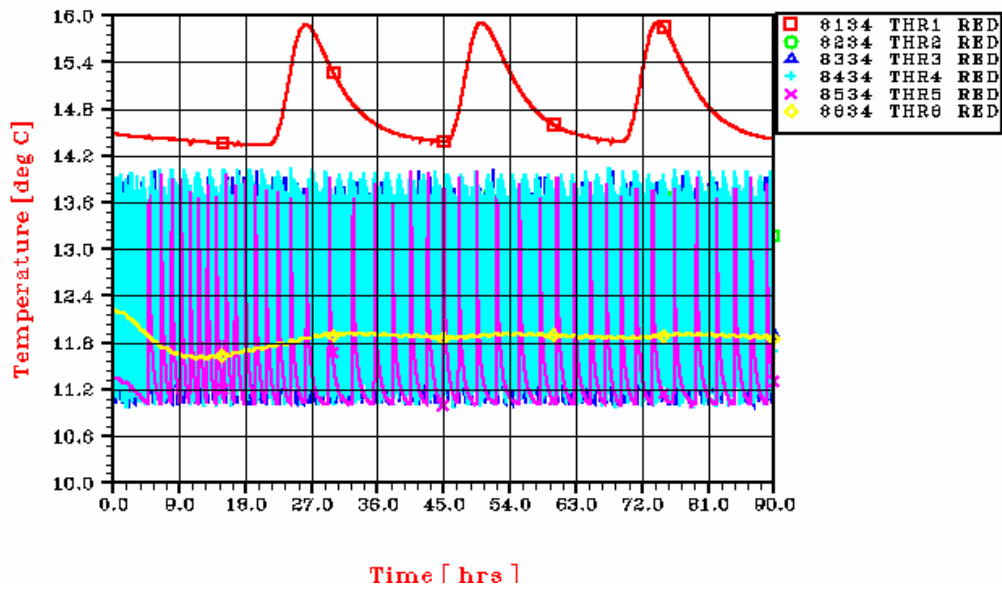

Controlled Distribution

10.3 HERSCHEL RESULTS OF CASE I

HERSCHEL SURVIVAL CASE I BOL

PANEL +Y+Z

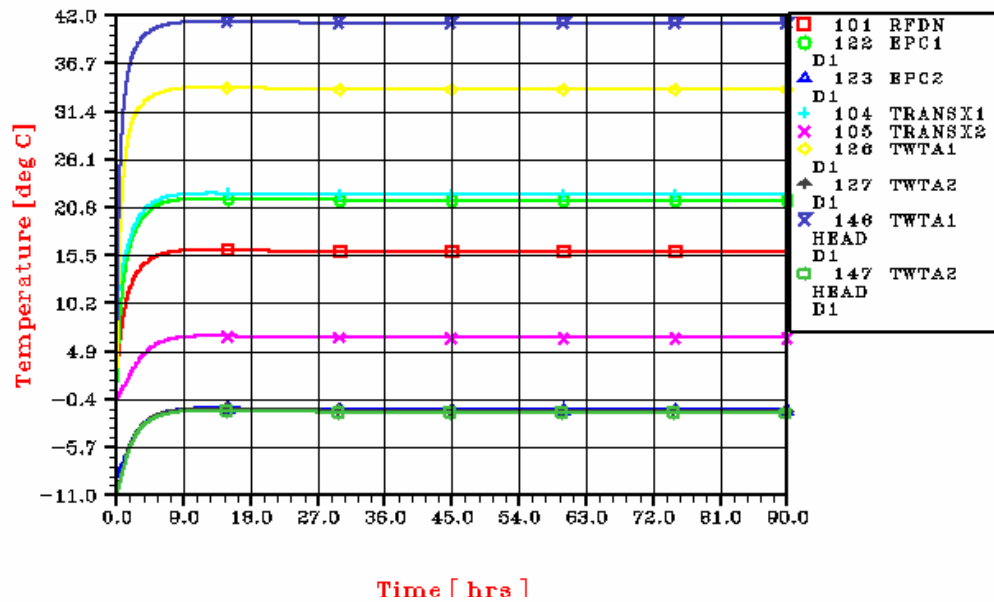

HERSCHEL SURVIVAL CASE I BOL

INTERNAL UNITS

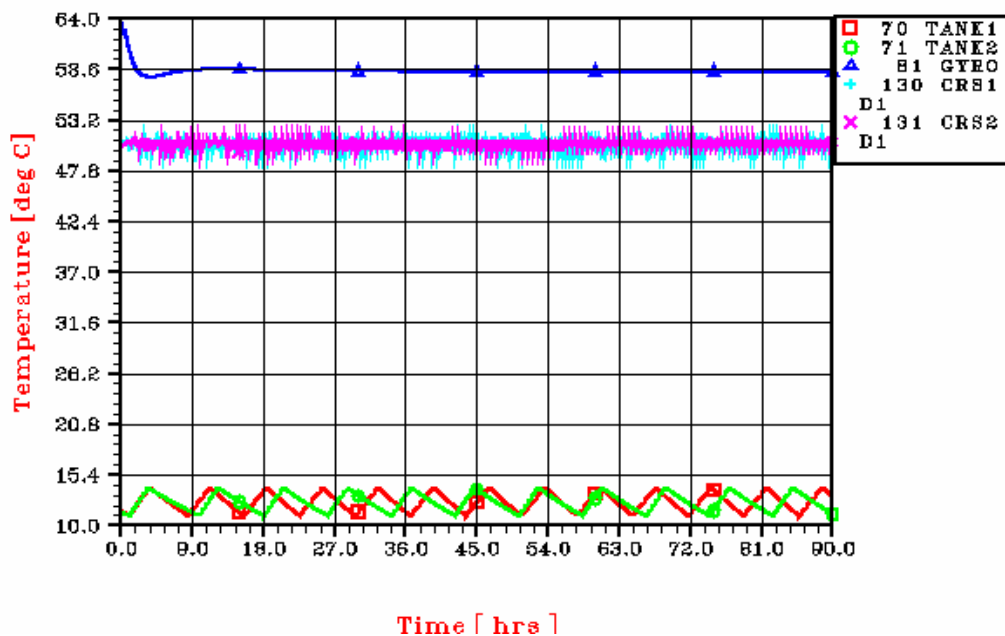

Controlled Distribution



REFERENCE : H-P-RP-AI-0040

DATE : 29/SEP/06

ISSUE : 06

Page : 279/405

HERSCHEL SURVIVAL CASE I BOL

PANEL +Y

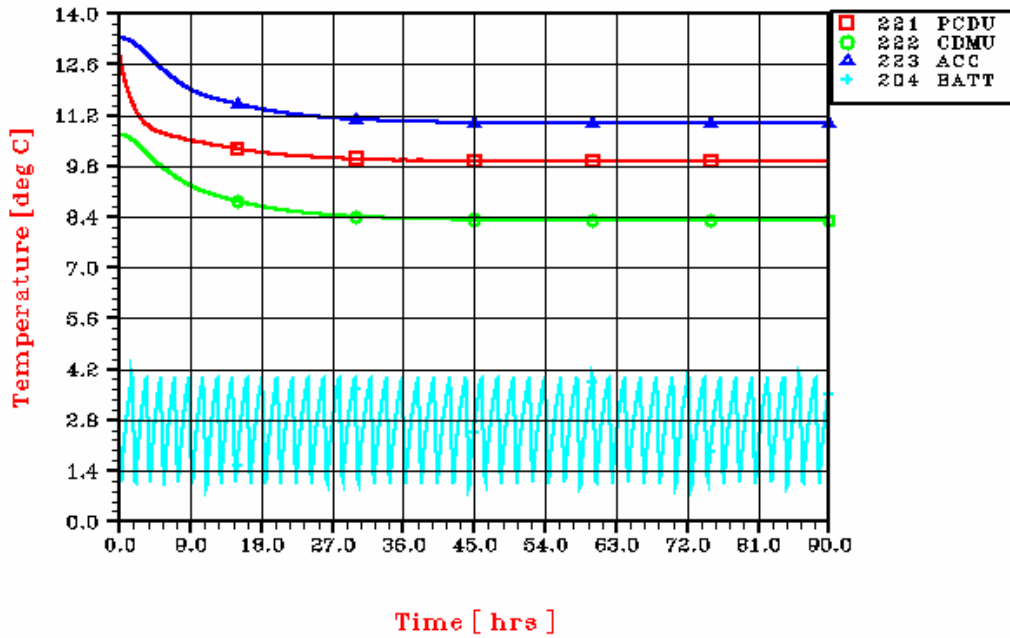

HERSCHEL SURVIVAL CASE I BOL

PANEL +Y-Z

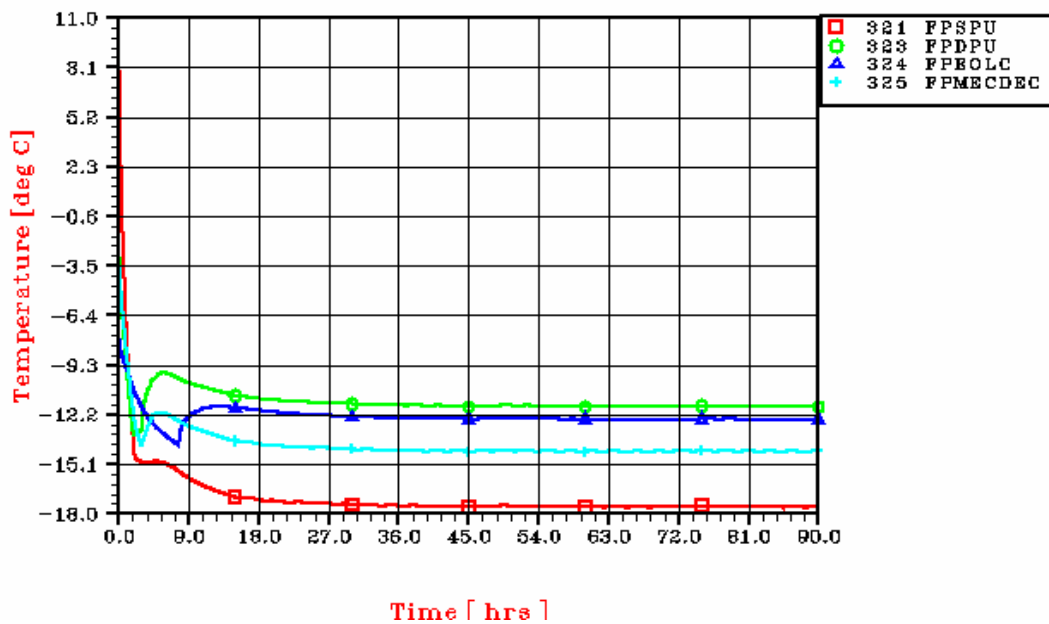

Controlled Distribution



REFERENCE : H-P-RP-AI-0040

DATE : 29/SEP/06

ISSUE : 06

Page : 281/405

HERSCHEL SURVIVAL CASE I BOL

PANEL -Y

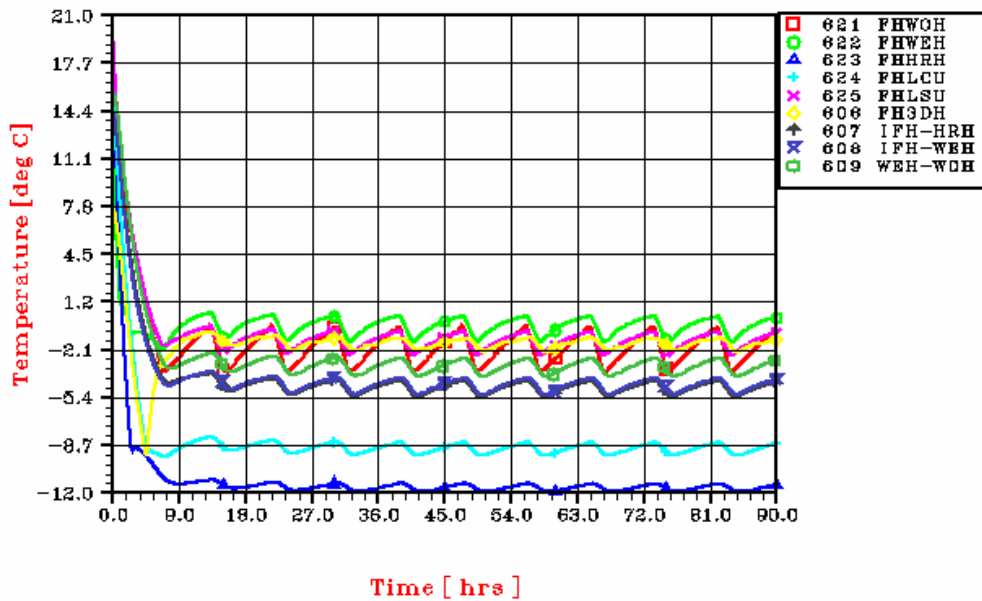

HERSCHEL SURVIVAL CASE I BOL

PANEL -Y+Z

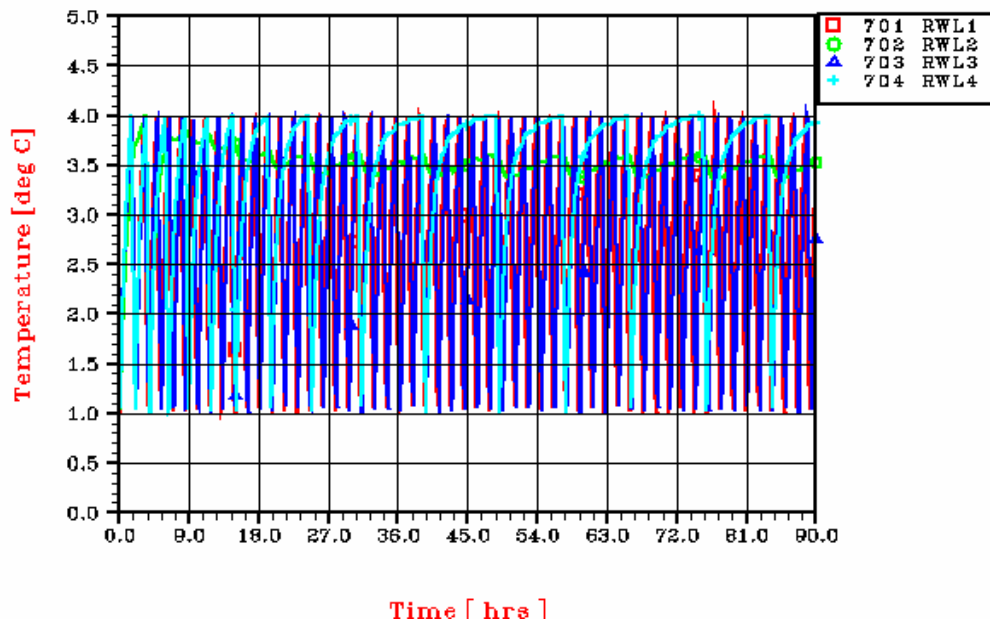

Controlled Distribution



REFERENCE : H-P-RP-AI-0040

DATE : 29/SEP/06

ISSUE : 06

Page : 282/405

HERSCHEL SURVIVAL CASE I BOL EXTERNAL UNITS

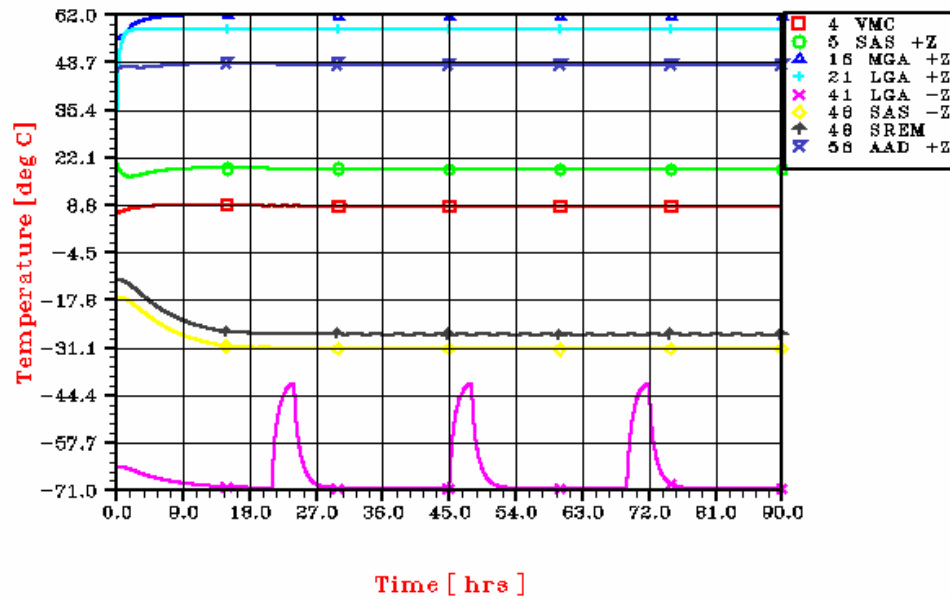

HERSCHEL SURVIVAL CASE I BOL STR

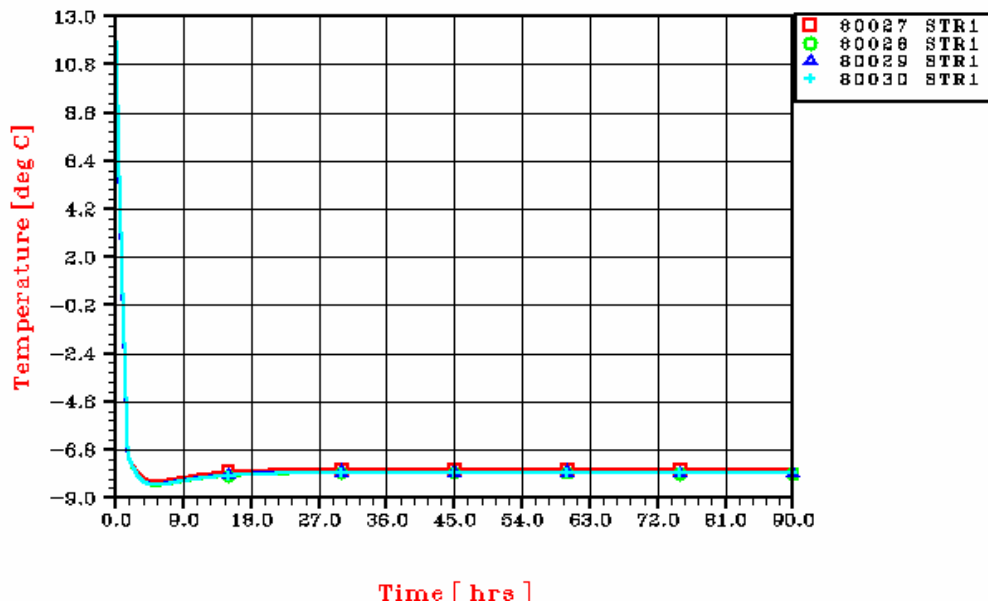

Controlled Distribution



REFERENCE : H-P-RP-AI-0040

DATE : 29/SEP/06

ISSUE : 06

Page : 283/405

HERSCHEL SURVIVAL CASE I BOL STR BASEPLATE

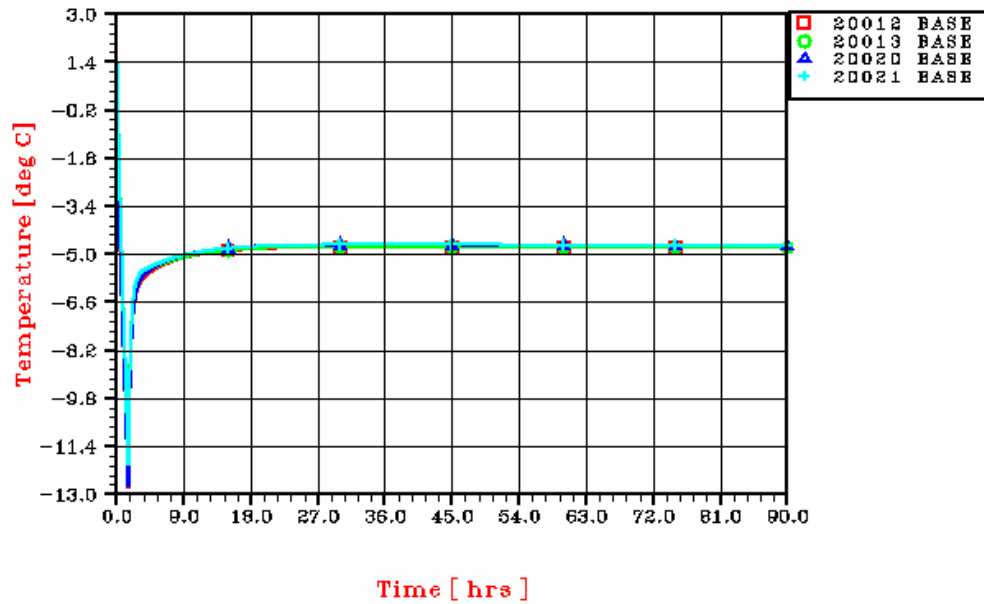

HERSCHEL SURVIVAL CASE I BOL STR

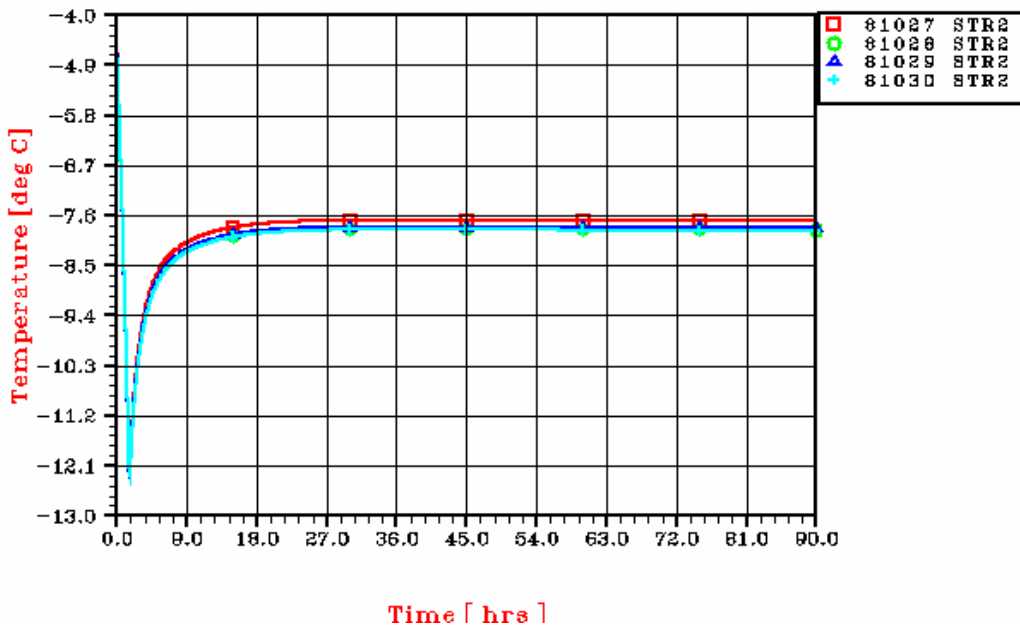

Controlled Distribution

HERSCHEL SURVIVAL CASE I BOL THRUSTERS MAIN

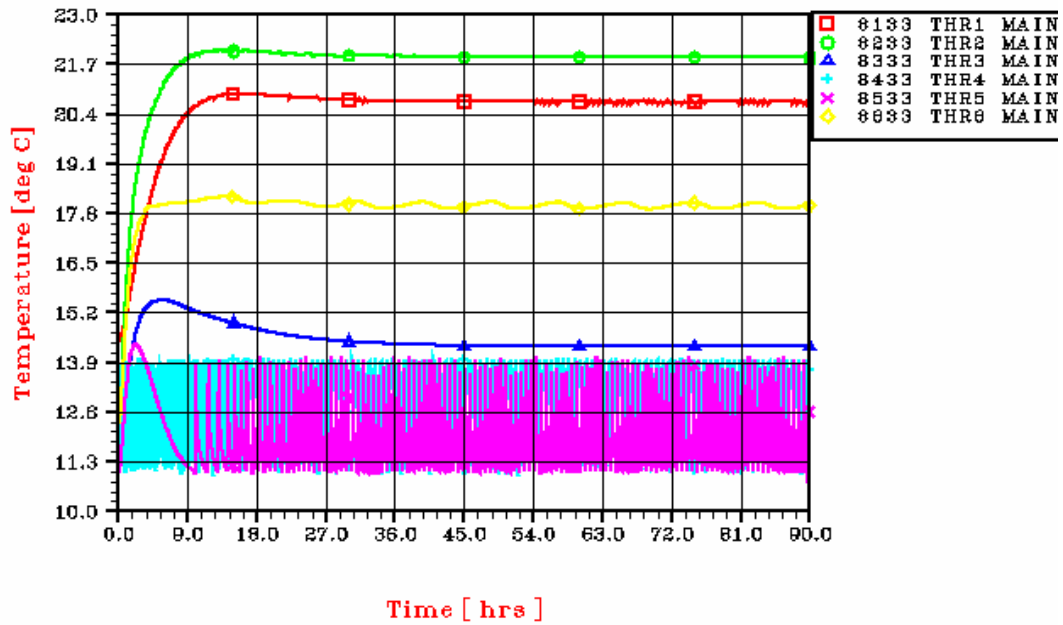

HERSCHEL SURVIVAL CASE I BOL THRUSTERS REDUNDANT

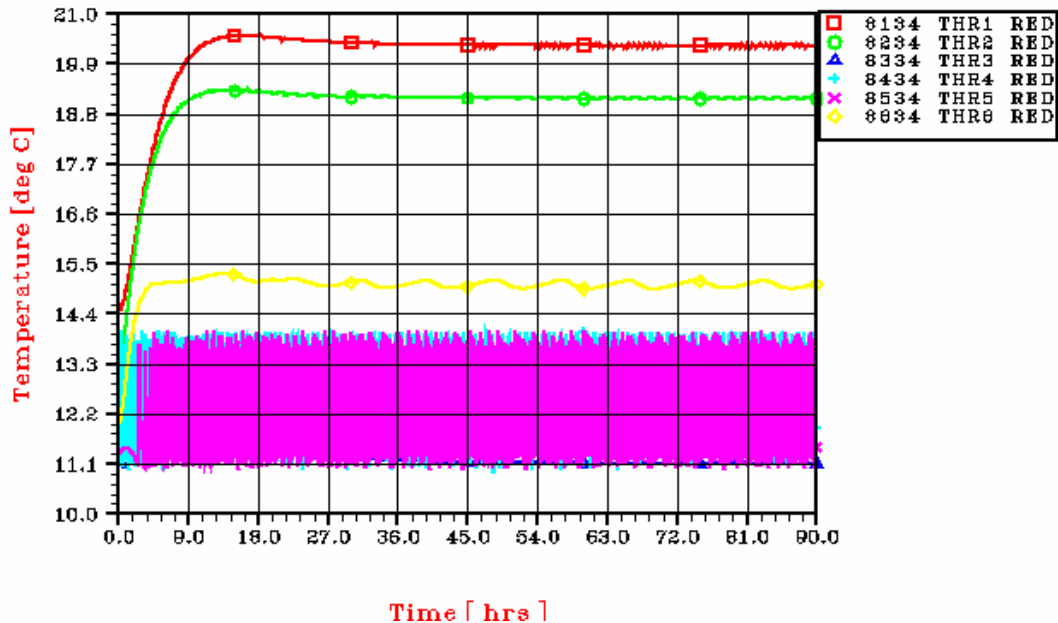

Controlled Distribution



REFERENCE : H-P-RP-AI-0040

DATE : 29/SEP/06

ISSUE : 06

Page : 285/405

10.4 HERSCHEL RESULTS OF CASE P

HERSCHEL ATTITUDE CHANGE BOL PANEL +Y+Z

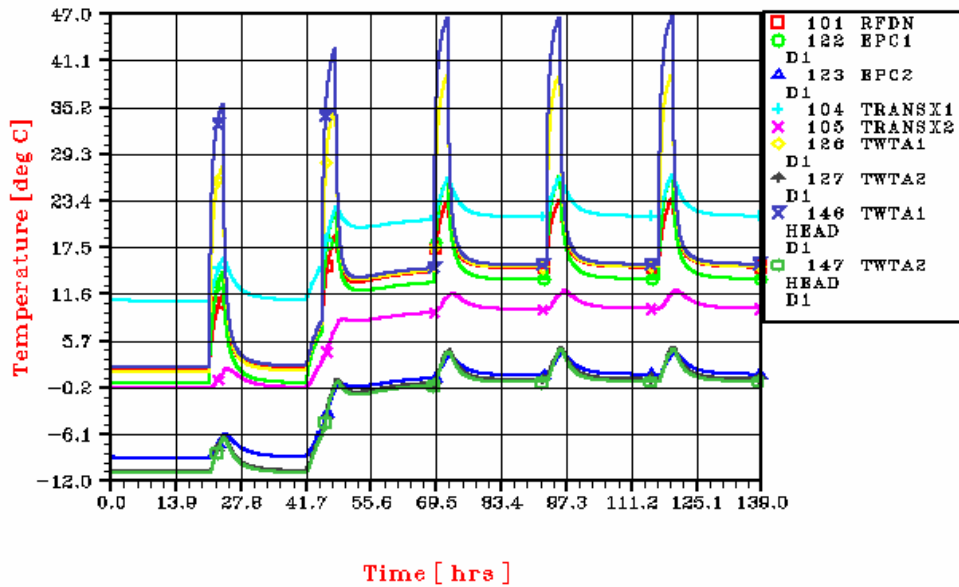

HERSCHEL ATTITUDE CHANGE BOL INTERNAL UNITS

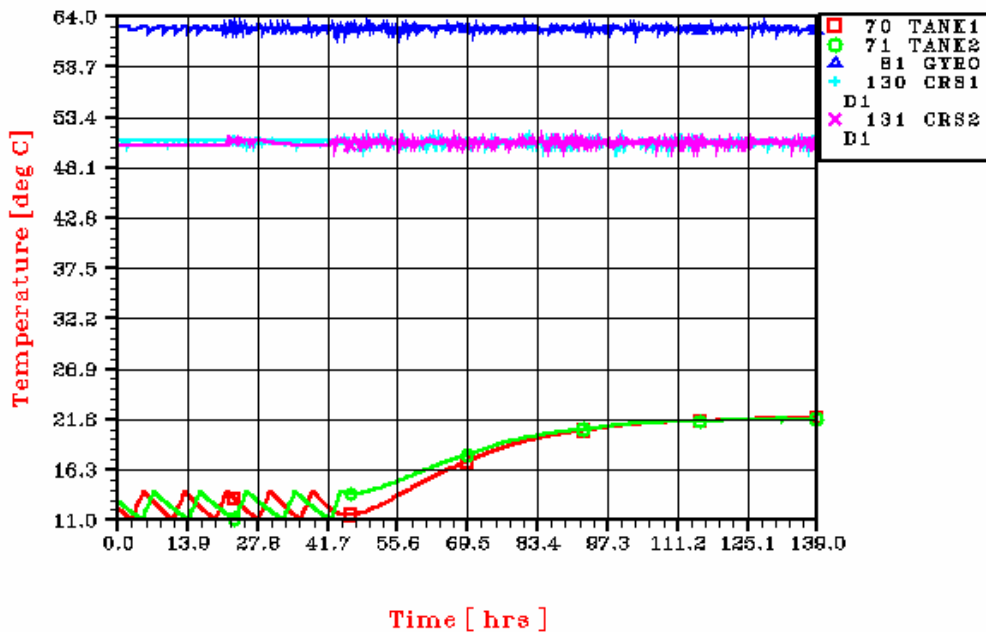

Controlled Distribution



REFERENCE : H-P-RP-AI-0040

DATE : 29/SEP/06

ISSUE : 06

Page : 286/405

HERSCHEL ATTITUDE CHANGE BOL PANEL +Y

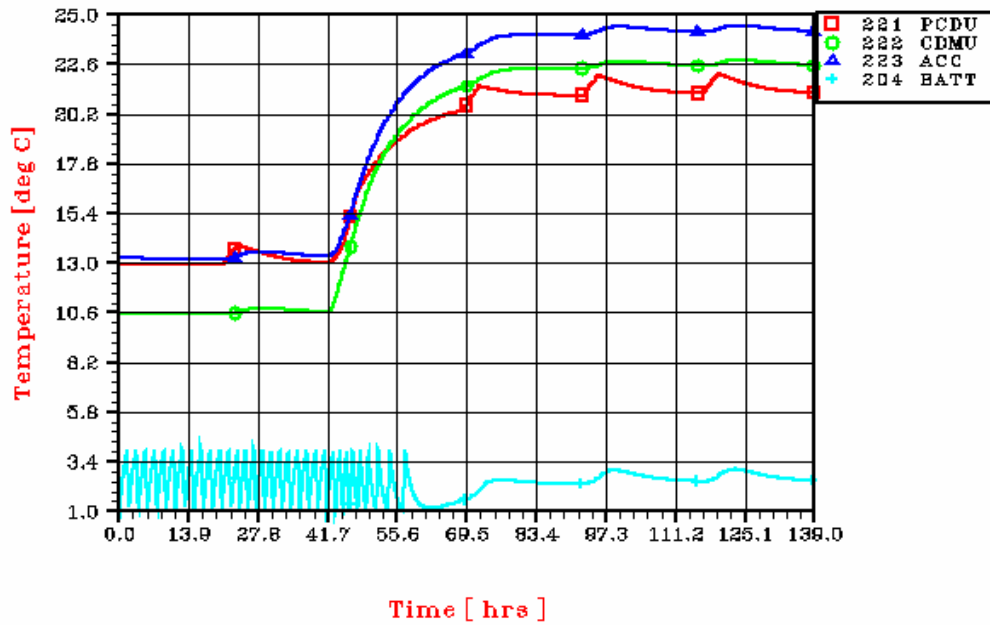

HERSCHEL ATTITUDE CHANGE BOL PANEL +Y-Z

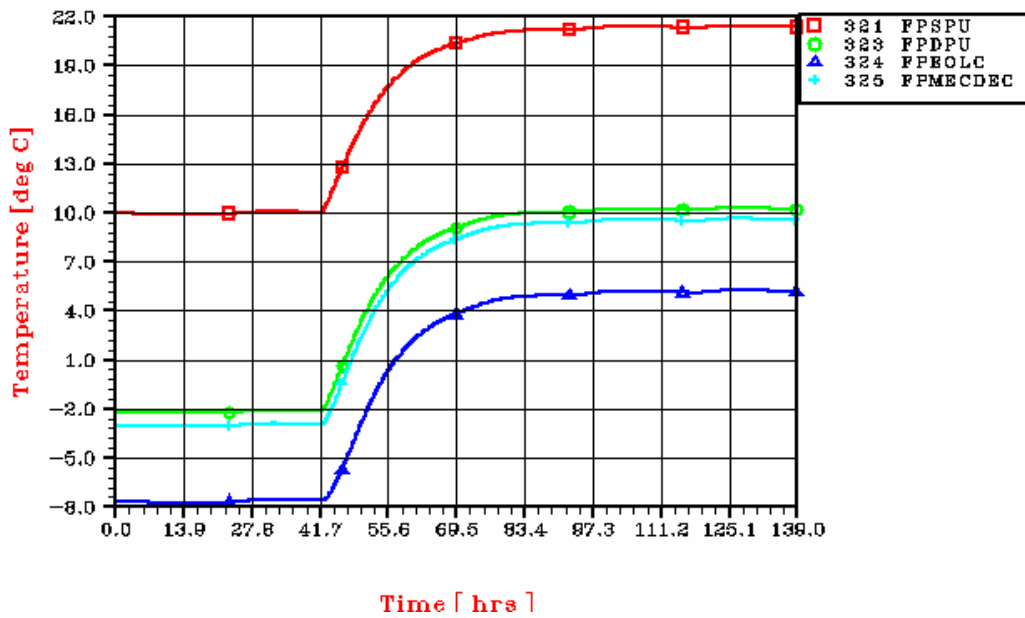

Controlled Distribution



REFERENCE : H-P-RP-AI-0040

DATE : 29/SEP/06

ISSUE : 06

Page : 287/405

HERSCHEL ATTITUDE CHANGE BOL PANEL -Z

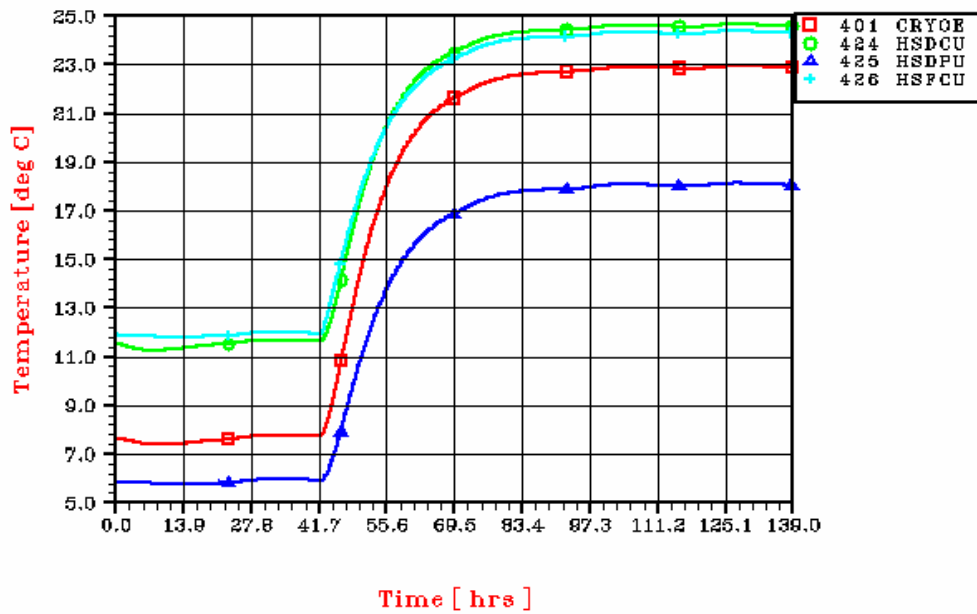

HERSCHEL ATTITUDE CHANGE BOL PANEL -Y-Z

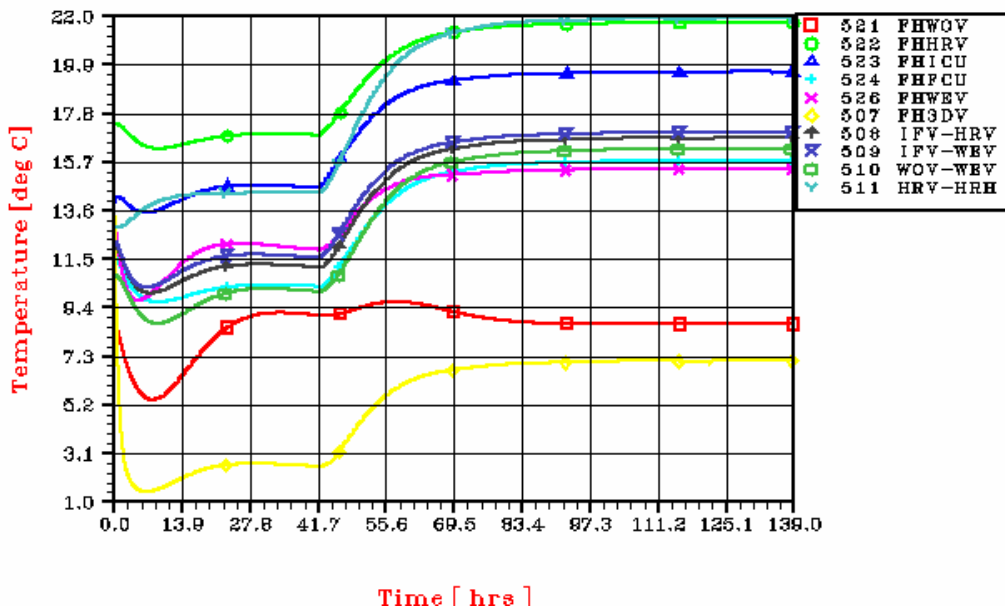

Controlled Distribution



REFERENCE : H-P-RP-AI-0040

DATE : 29/SEP/06

ISSUE : 06

Page : 288/405

HERSCHEL ATTITUDE CHANGE BOL

PANEL -Y

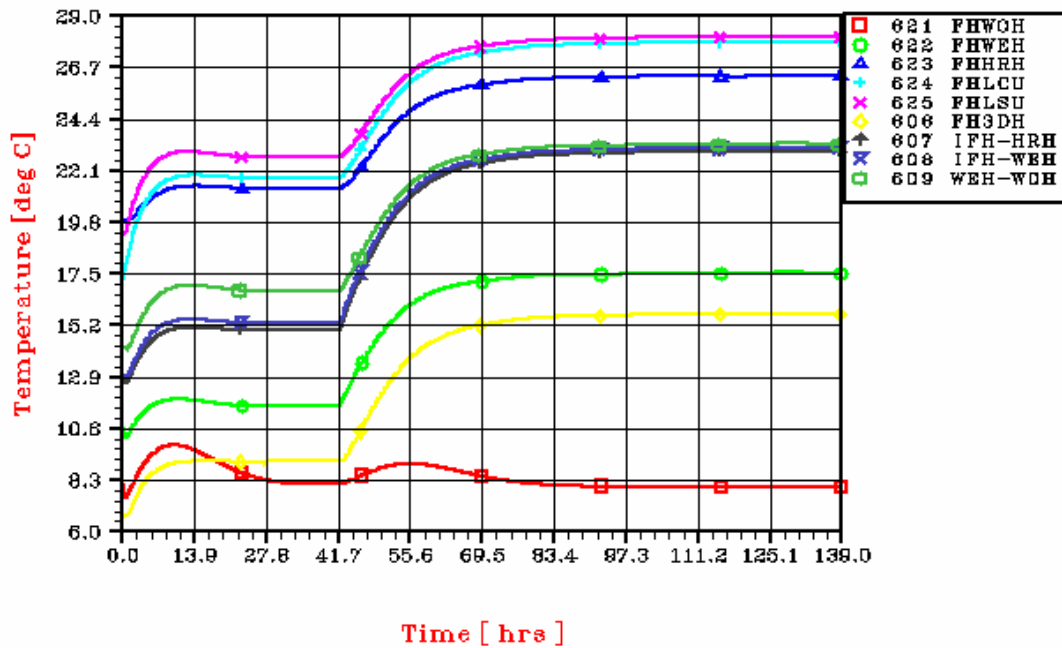

HERSCHEL ATTITUDE CHANGE BOL

PANEL -Y+Z

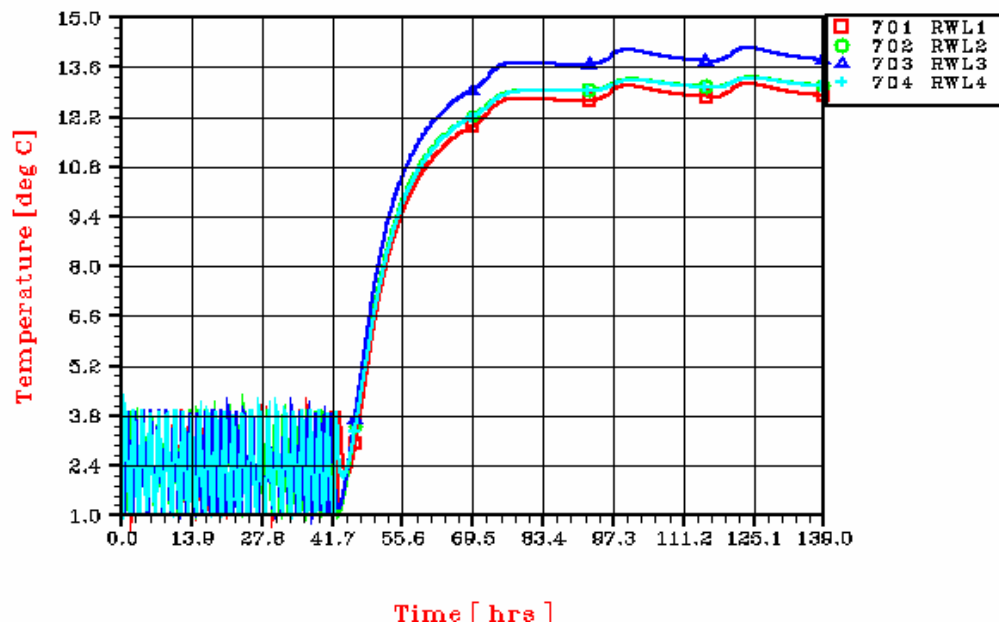

Controlled Distribution



REFERENCE : H-P-RP-AI-0040

DATE : 29/SEP/06

ISSUE : 06

Page : 289/405

HERSCHEL ATTITUDE CHANGE BOL EXTERNAL UNITS

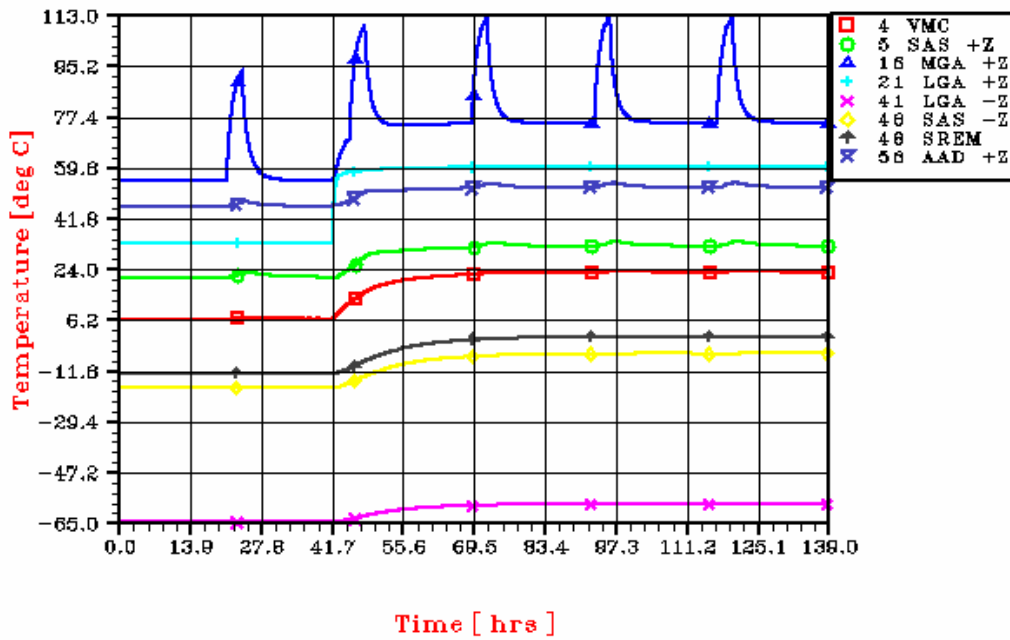

HERSCHEL ATTITUDE CHANGE BOL STR

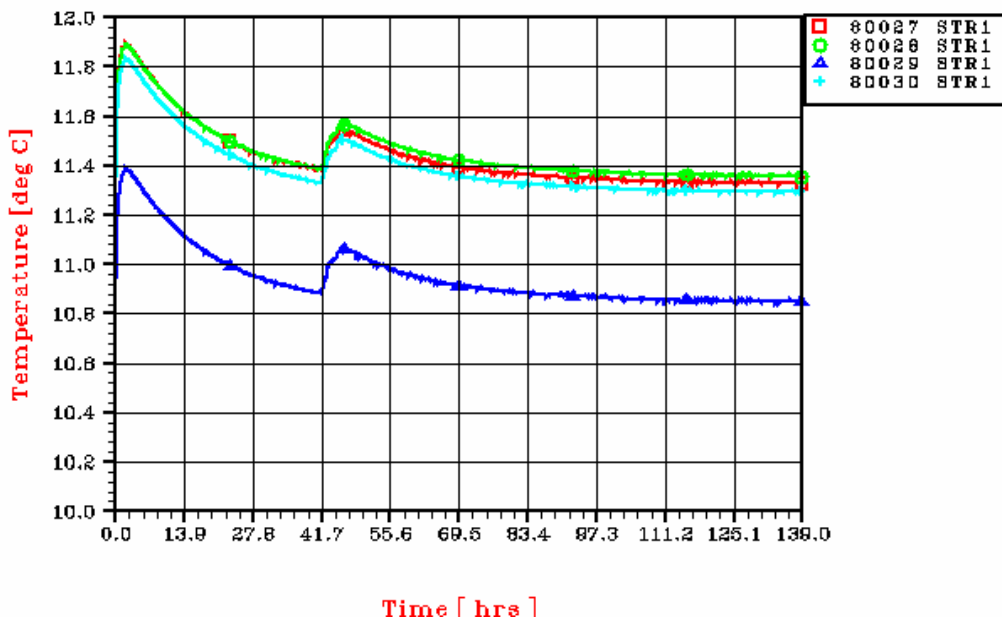

Controlled Distribution



REFERENCE : H-P-RP-AI-0040

DATE : 29/SEP/06

ISSUE : 06

Page : 290/405

HERSCHEL ATTITUDE CHANGE BOL STR BASEPLATE

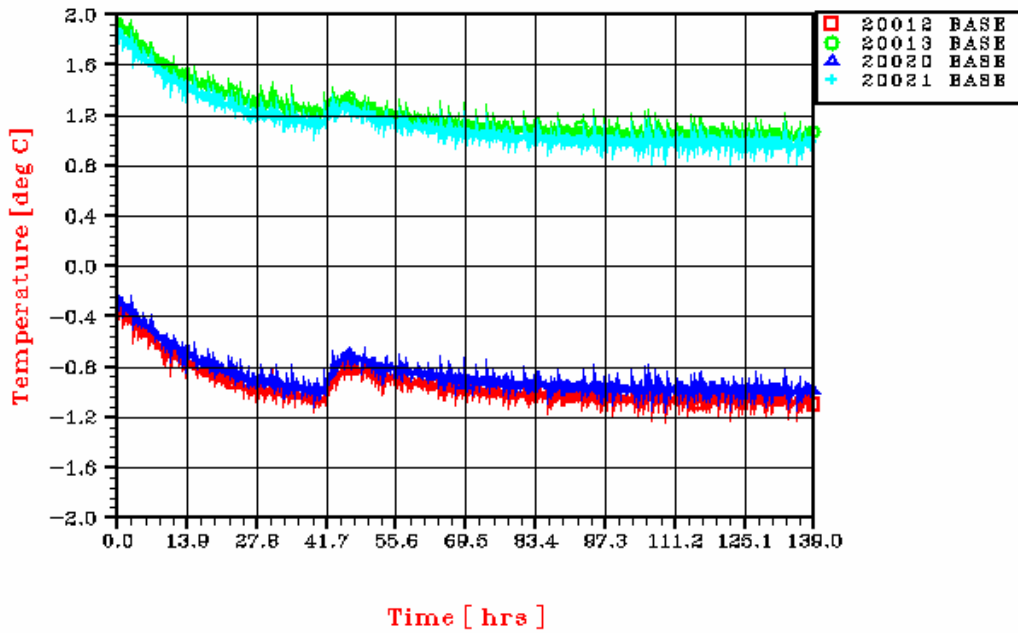

HERSCHEL ATTITUDE CHANGE BOL STR

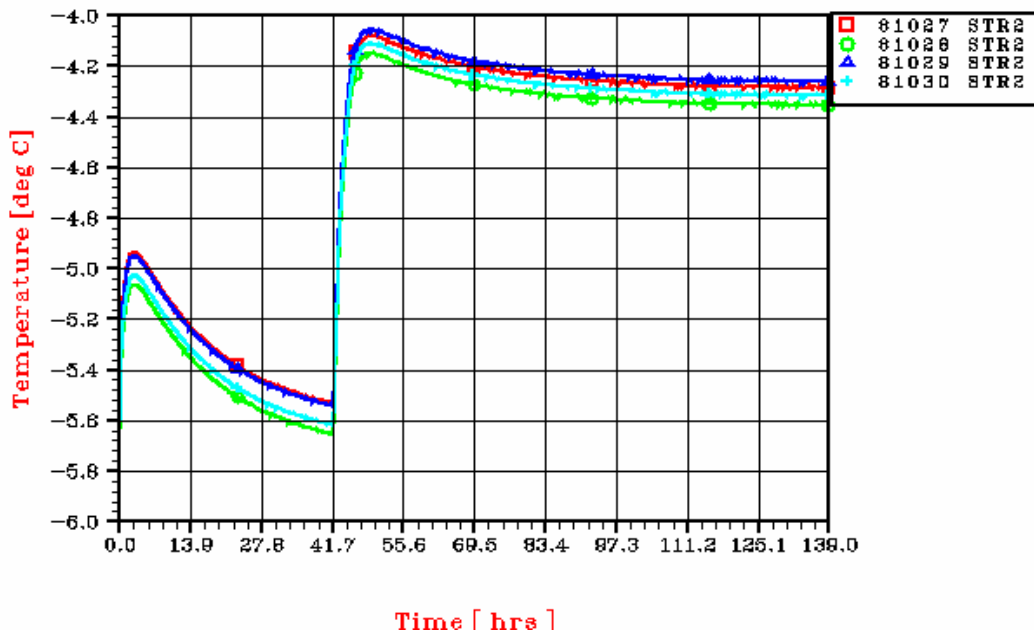

Controlled Distribution

HERSCHEL ATTITUDE CHANGE BOL THRUSTERS MAIN

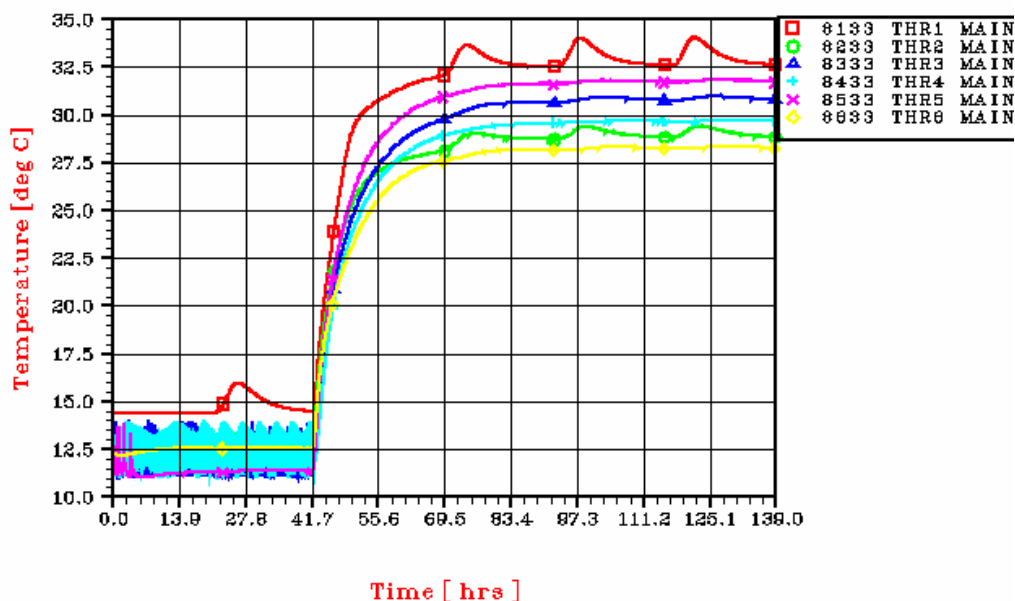

HERSCHEL ATTITUDE CHANGE BOL THRUSTERS REDUNDANT

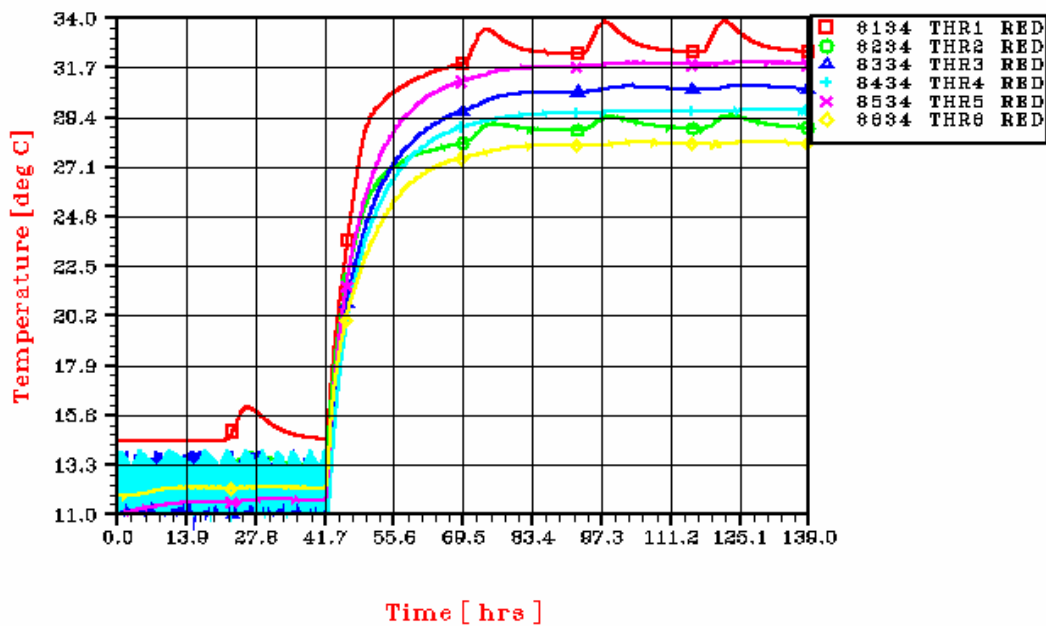

Controlled Distribution

10.5 HERSCHEL RESULTS OF CASE Q

HERSCHEL ATTITUDE CHANGE EOL

PANEL +Y+Z

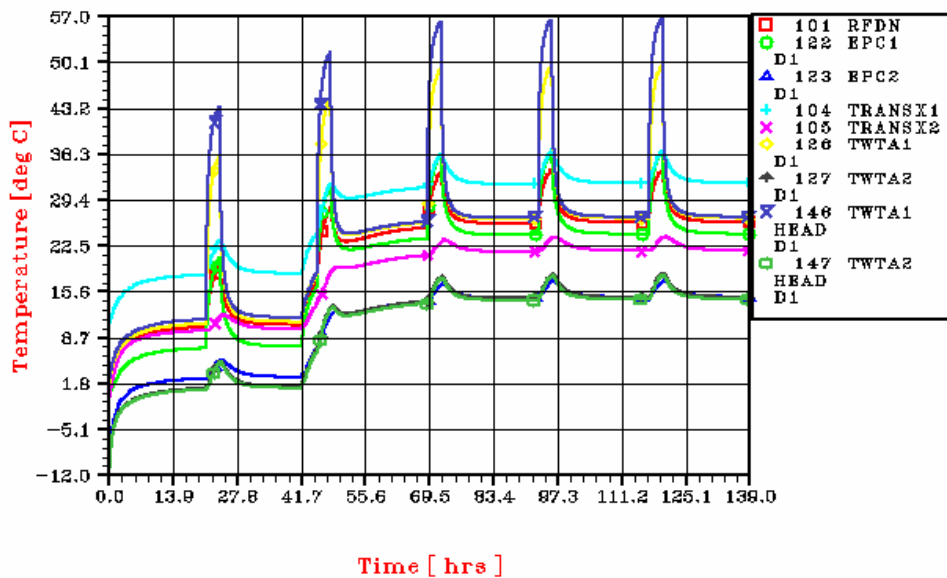

HERSCHEL ATTITUDE CHANGE EOL

INTERNAL UNITS

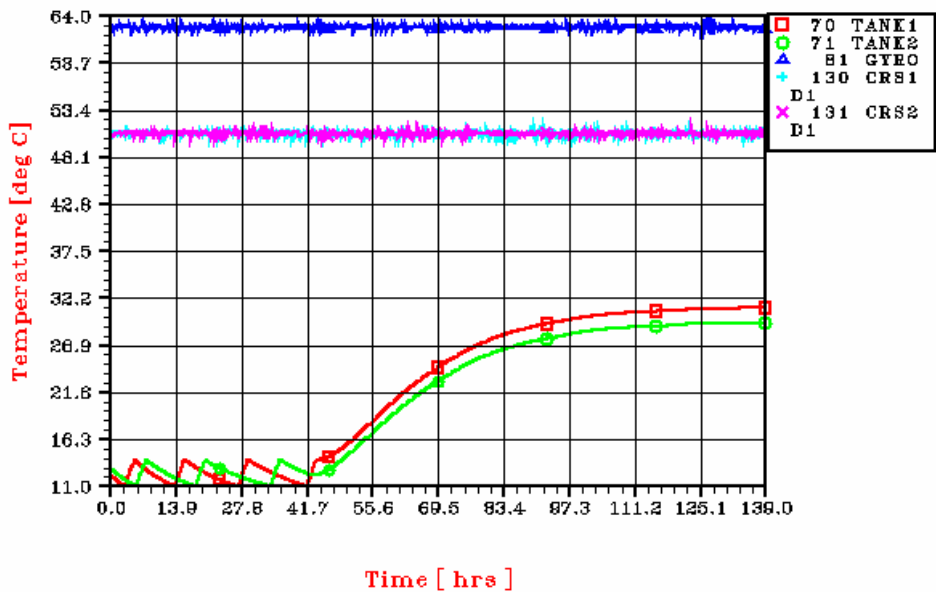

Controlled Distribution



REFERENCE : H-P-RP-AI-0040

DATE : 29/SEP/06

ISSUE : 06

Page : 293/405

HERSCHEL ATTITUDE CHANGE EOL PANEL +Y

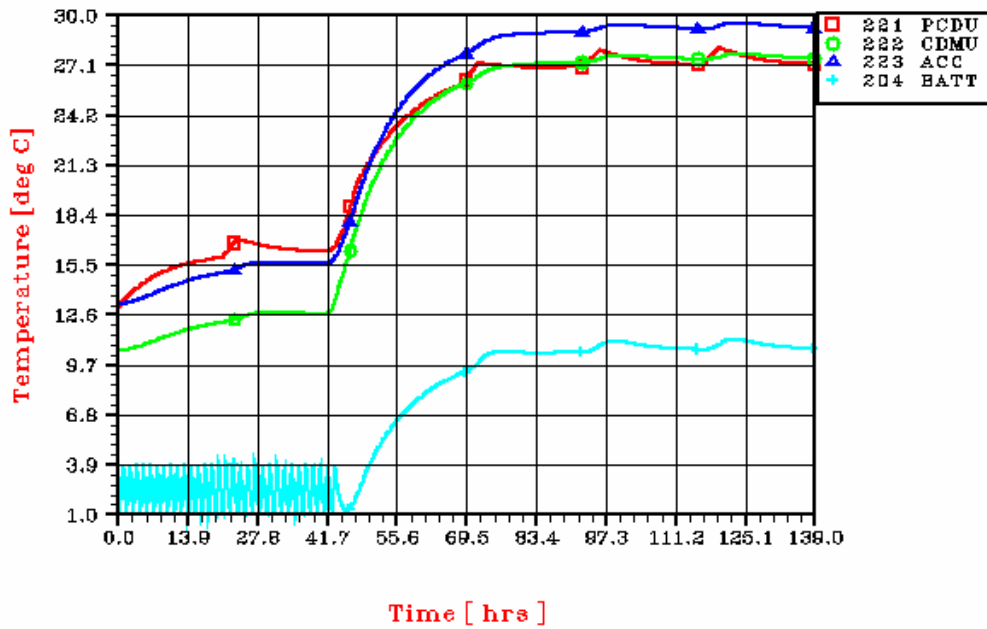

HERSCHEL ATTITUDE CHANGE EOL PANEL +Y-Z

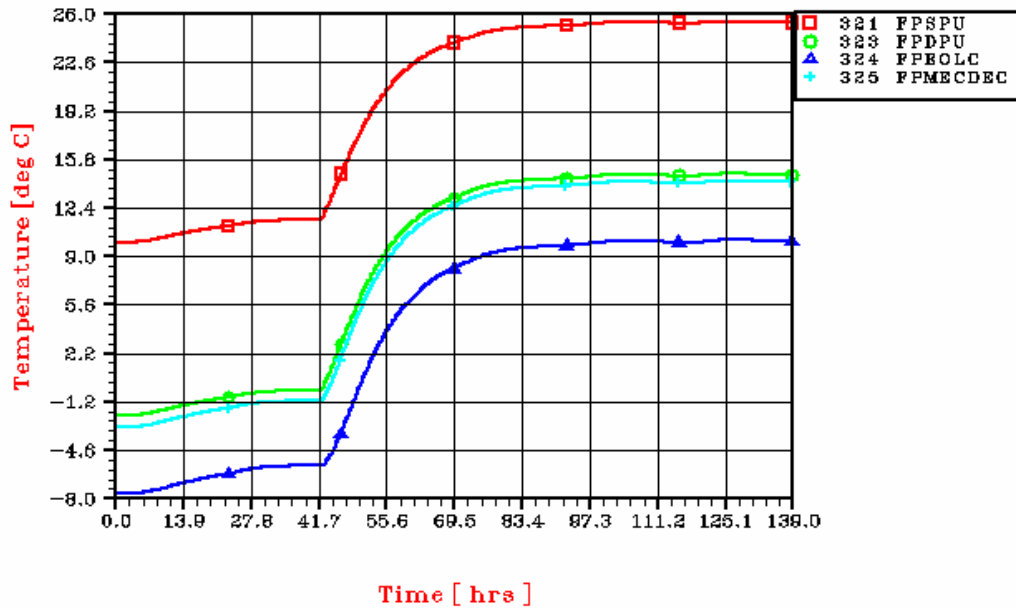

Controlled Distribution



REFERENCE : H-P-RP-AI-0040

DATE : 29/SEP/06

ISSUE : 06

Page : 294/405

HERSCHEL ATTITUDE CHANGE EOL PANEL -Z

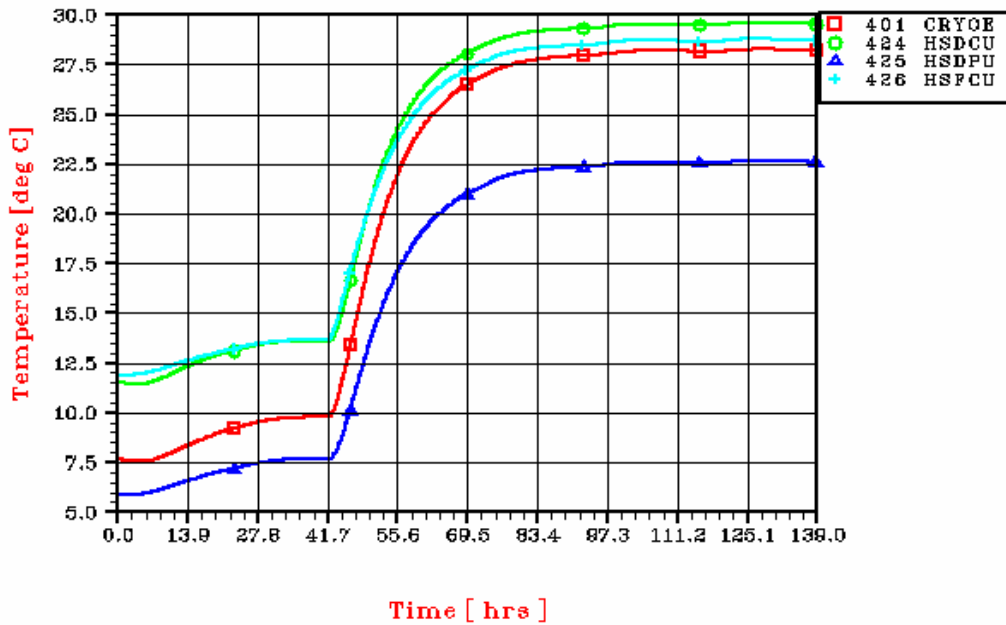

HERSCHEL ATTITUDE CHANGE EOL PANEL -Y-Z

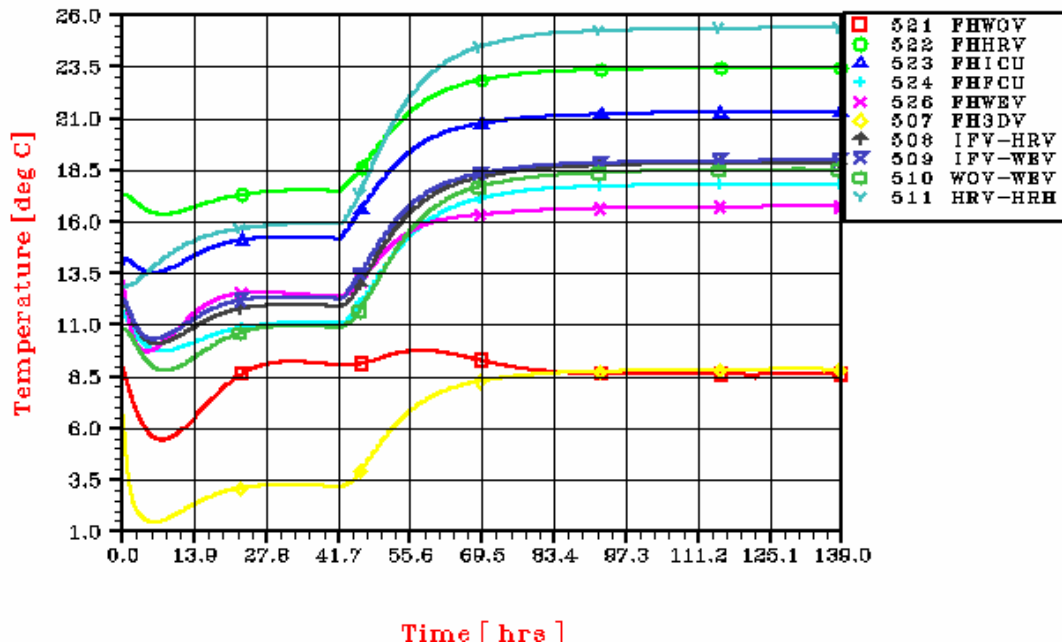

Controlled Distribution



REFERENCE : H-P-RP-AI-0040

DATE : 29/SEP/06

ISSUE : 06

Page : 295/405

HERSCHEL ATTITUDE CHANGE EOL

PANEL -Y

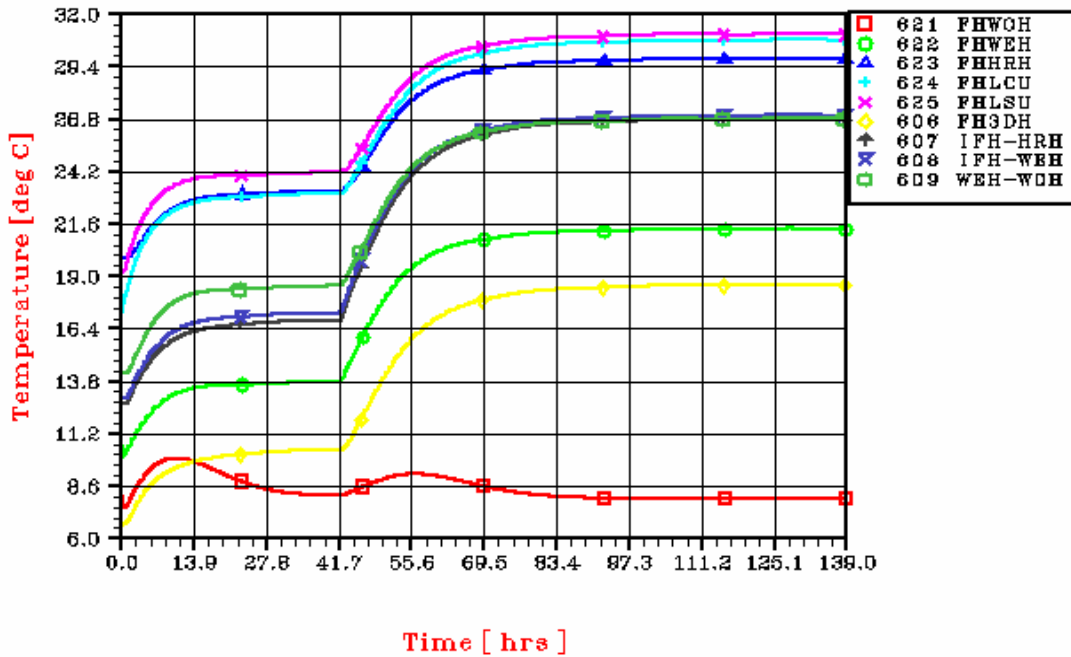

HERSCHEL ATTITUDE CHANGE EOL

PANEL -Y+Z

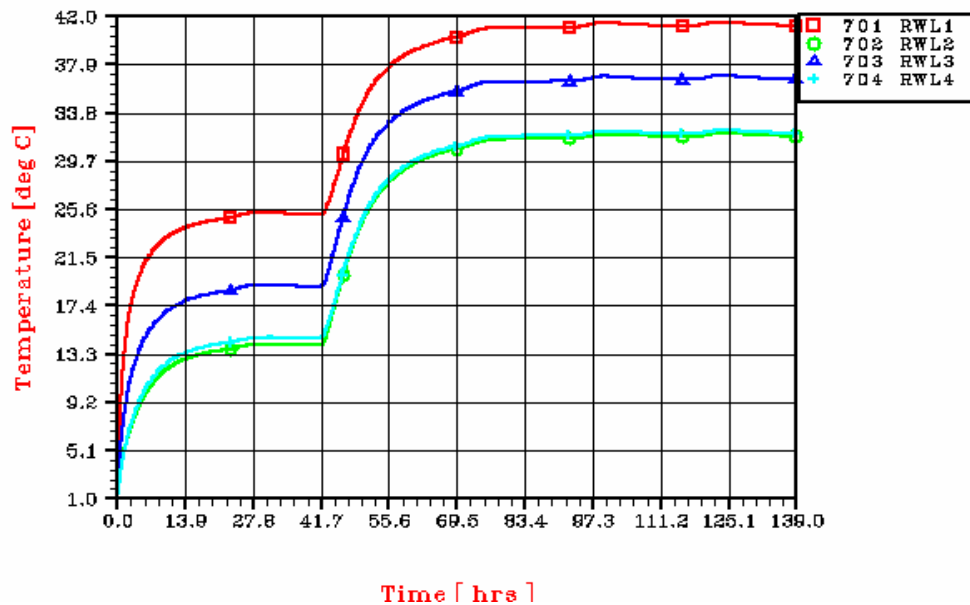

Controlled Distribution



REFERENCE : H-P-RP-AI-0040

DATE : 29/SEP/06

ISSUE : 06

Page : 296/405

HERSCHEL ATTITUDE CHANGE EOL EXTERNAL UNITS

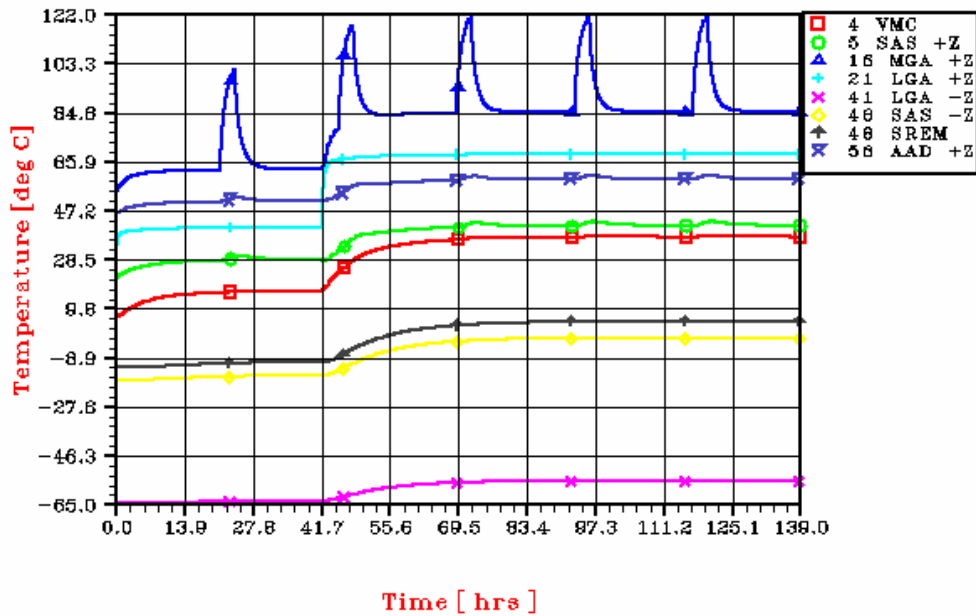

HERSCHEL ATTITUDE CHANGE EOL STR

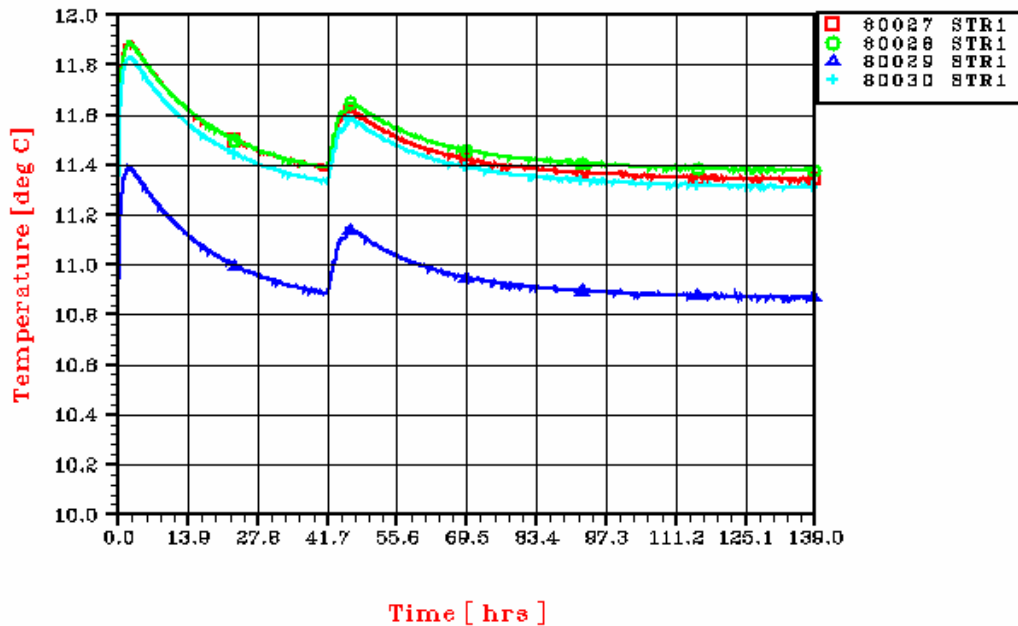

Controlled Distribution



REFERENCE : H-P-RP-AI-0040

DATE : 29/SEP/06

ISSUE : 06

Page : 297/405

HERSCHEL ATTITUDE CHANGE EOL STR BASEPLATE

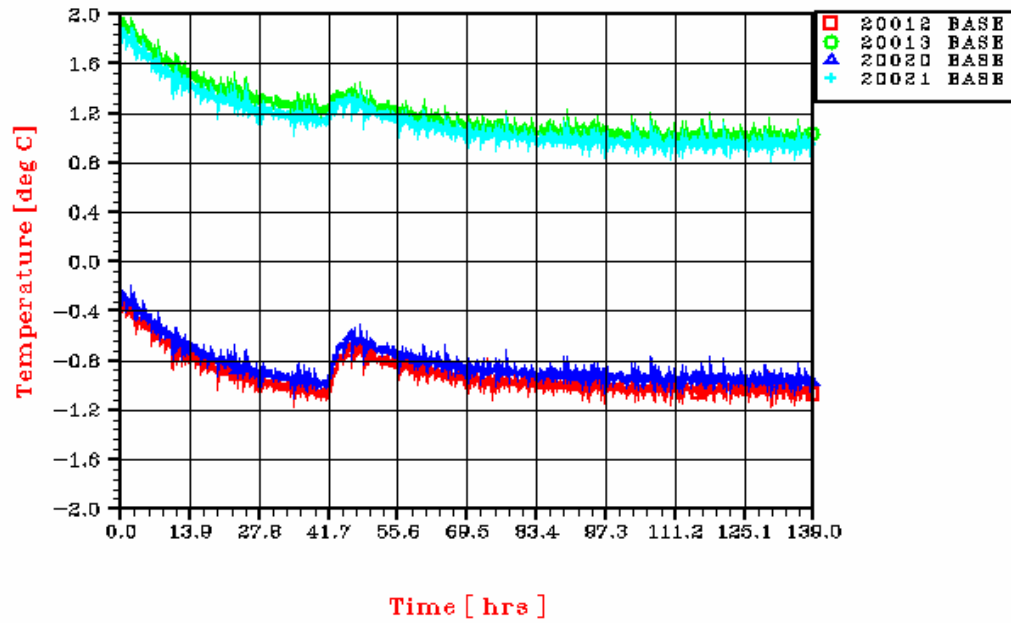

HERSCHEL ATTITUDE CHANGE EOL STR

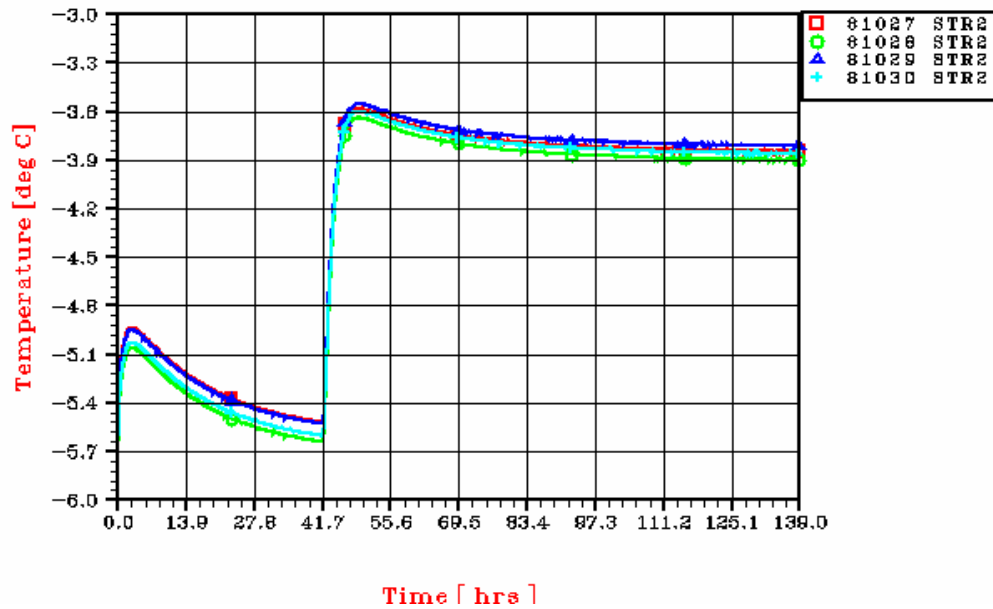

Controlled Distribution



REFERENCE : H-P-RP-AI-0040

DATE : 29/SEP/06

ISSUE : 06

Page : 298/405

HERSCHEL ATTITUDE CHANGE EOL THRUSTERS MAIN

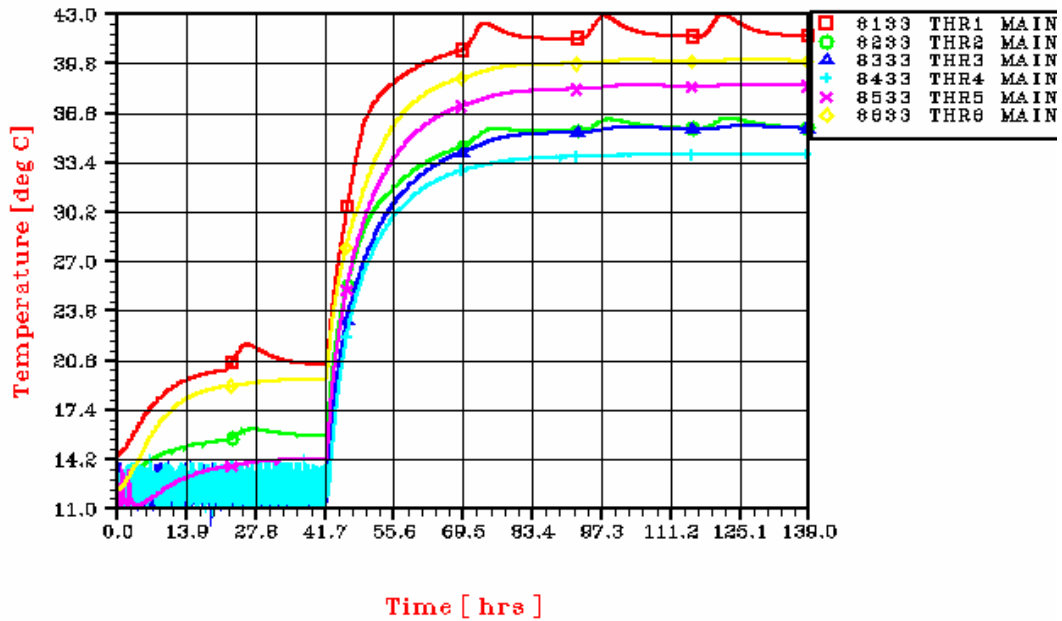

HERSCHEL ATTITUDE CHANGE EOL THRUSTERS REDUNDANT

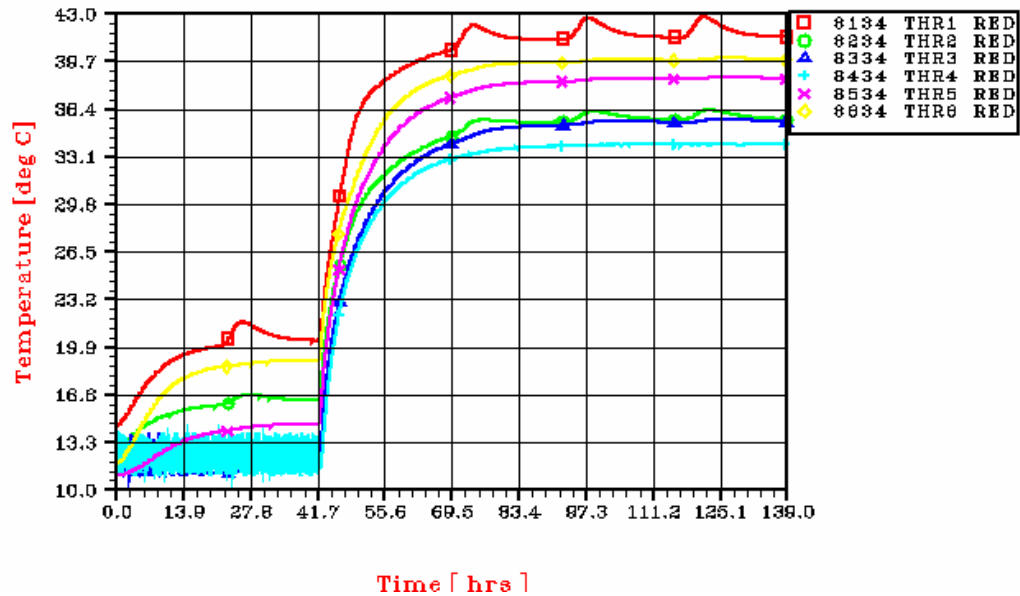

Controlled Distribution

REFERENCE : H-P-RP-AI-0040

DATE : 29/SEP/06

ISSUE : 06

Page : 299/405

11 PLANCK: TEMPERATURE PLOTS

11.1 PLANCK: PLOTS OF TRANSIENT NOMINAL ANALYSIS CASE A3

In the following figures, the temperature plots of the transient nominal analysis concerning the satellite in BOLcondition and in configuration Mode 3 (Case A3).

Controlled Distribution

REFERENCE : H-P-RP-AI-0040

DATE : 29/SEP/06

ISSUE : 06

Page : 300/405

PLANCK - CASE A3 BOL Mode3
LATERAL PANEL +Z

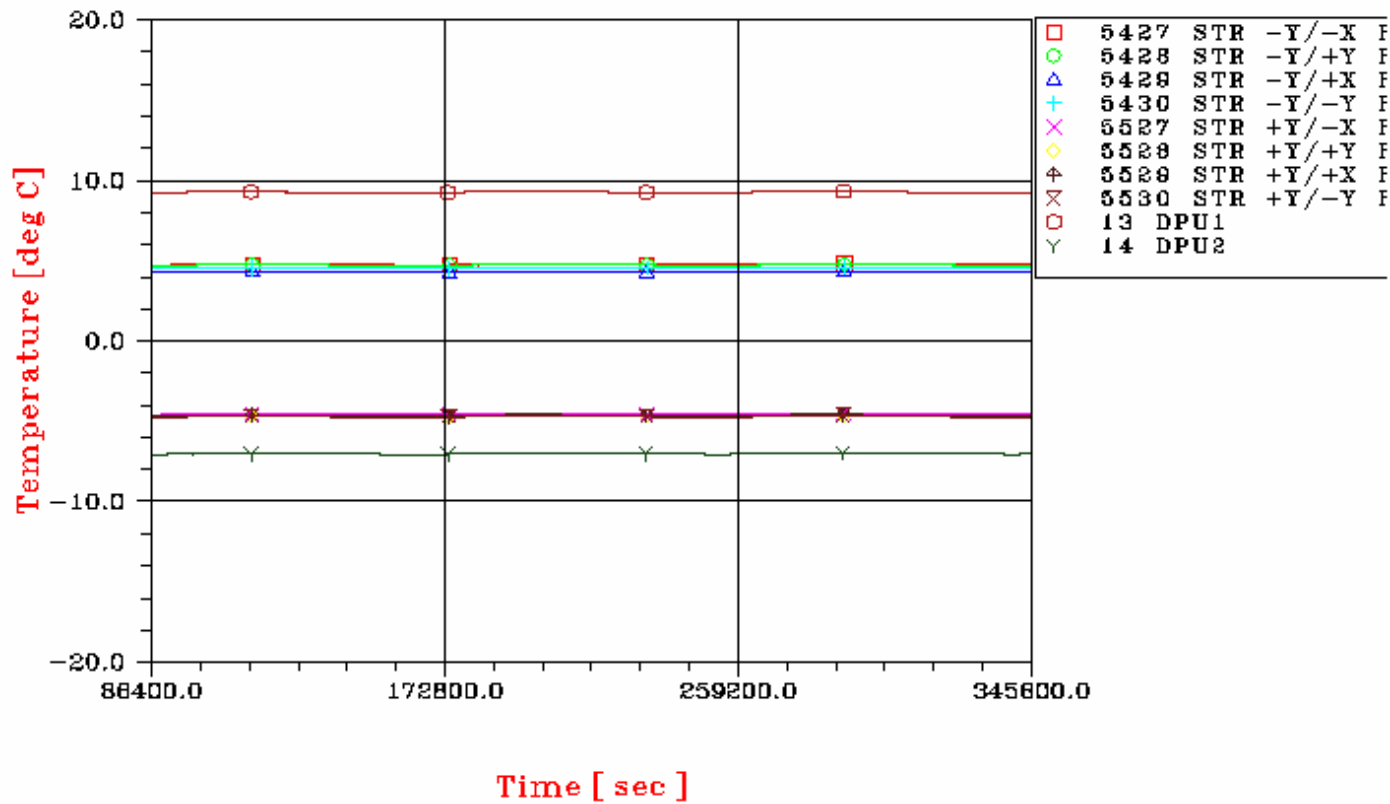

Controlled Distribution

REFERENCE : H-P-RP-AI-0040

DATE : 29/SEP/06

ISSUE : 06

Page : 301/405

PLANCK – CASE A3 BOL Mode3

LATERAL PANEL +Z+Y

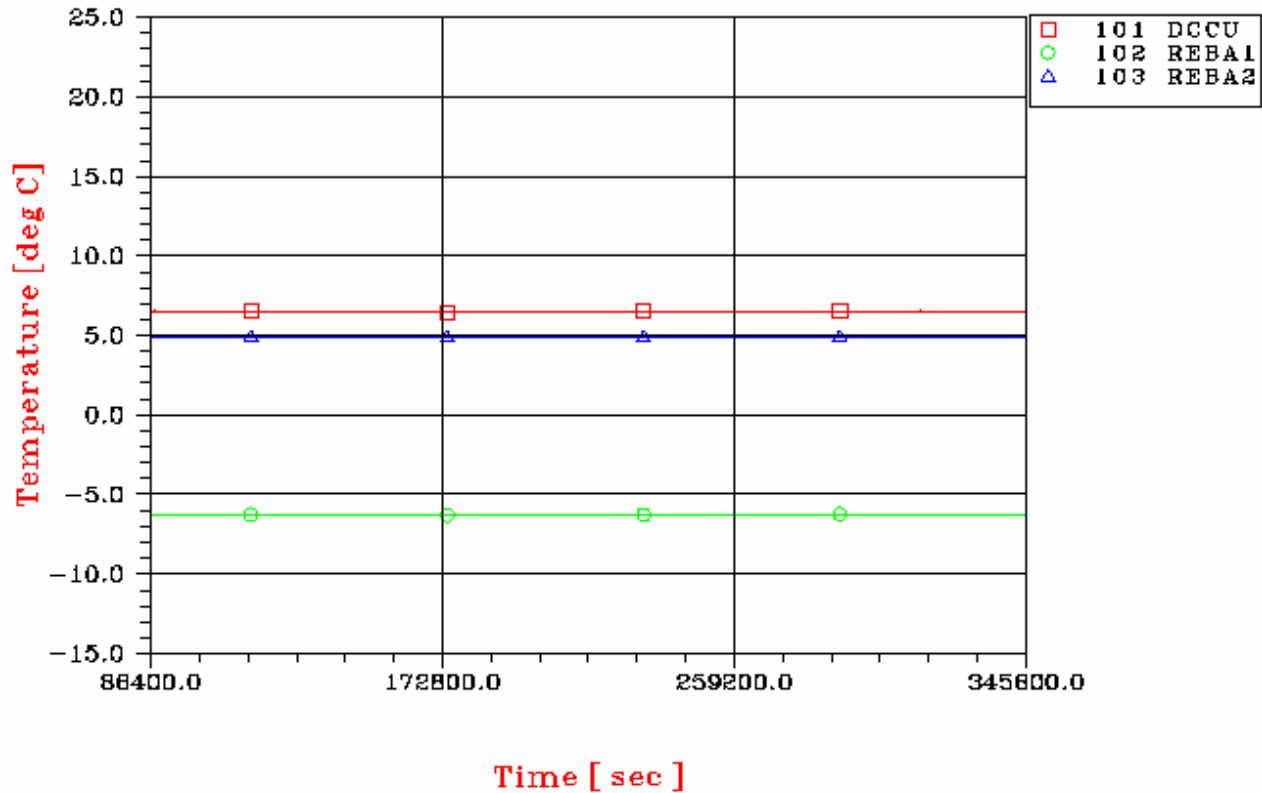

Controlled Distribution

REFERENCE : H-P-RP-AI-0040

DATE : 29/SEP/06

ISSUE : 06

Page : 302/405

PLANCK – CASE A3 BOL Mode3
SHEAR PANEL – FOG/CRU

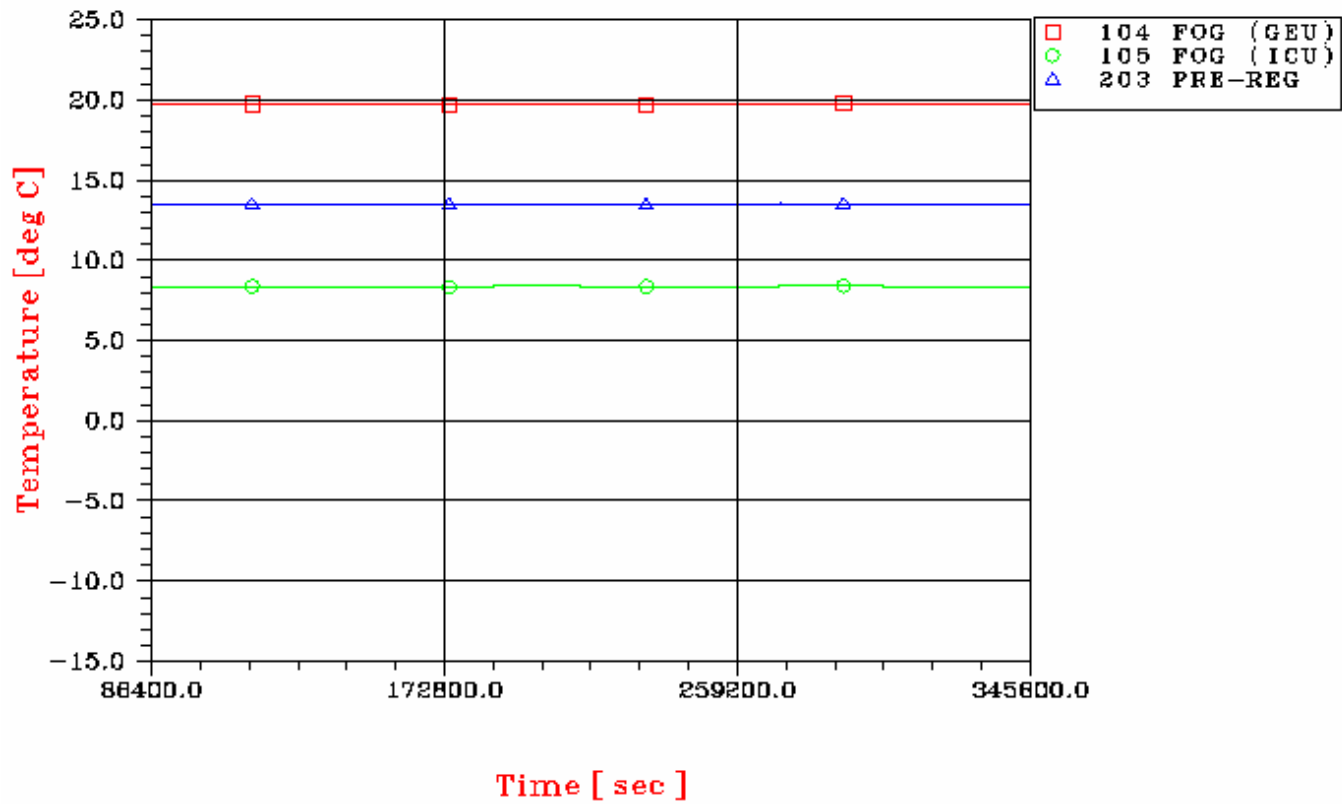

Controlled Distribution

REFERENCE : H-P-RP-AI-0040

DATE : 29/SEP/06

ISSUE : 06

Page : 303/405

PLANCK - CASE A3 BOL Mode3
LATERAL PANEL +Y

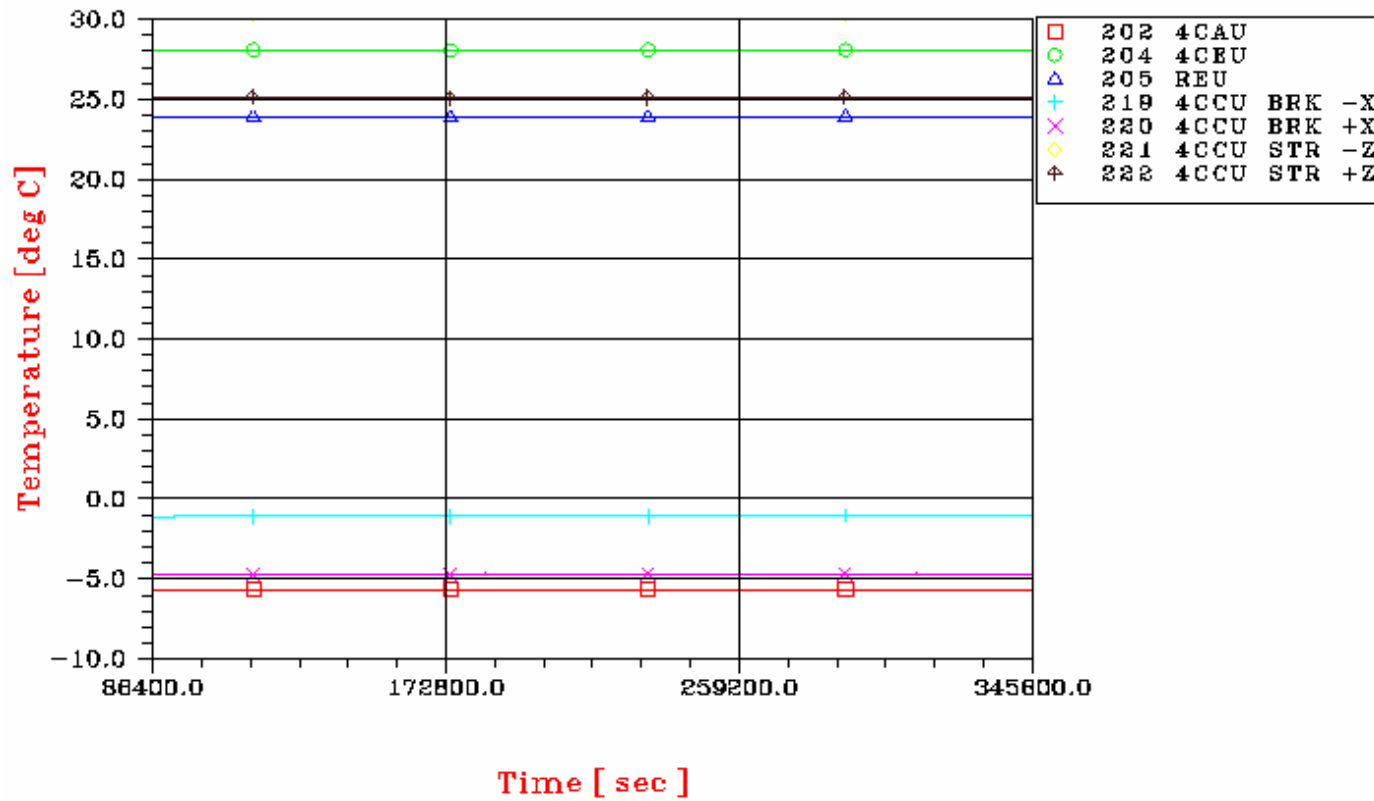

Controlled Distribution

REFERENCE : H-P-RP-AI-0040

DATE : 29/SEP/06

ISSUE : 06

Page : 304/405

PLANCK – CASE A3 BOL Mode3
LATERAL PANEL – Z

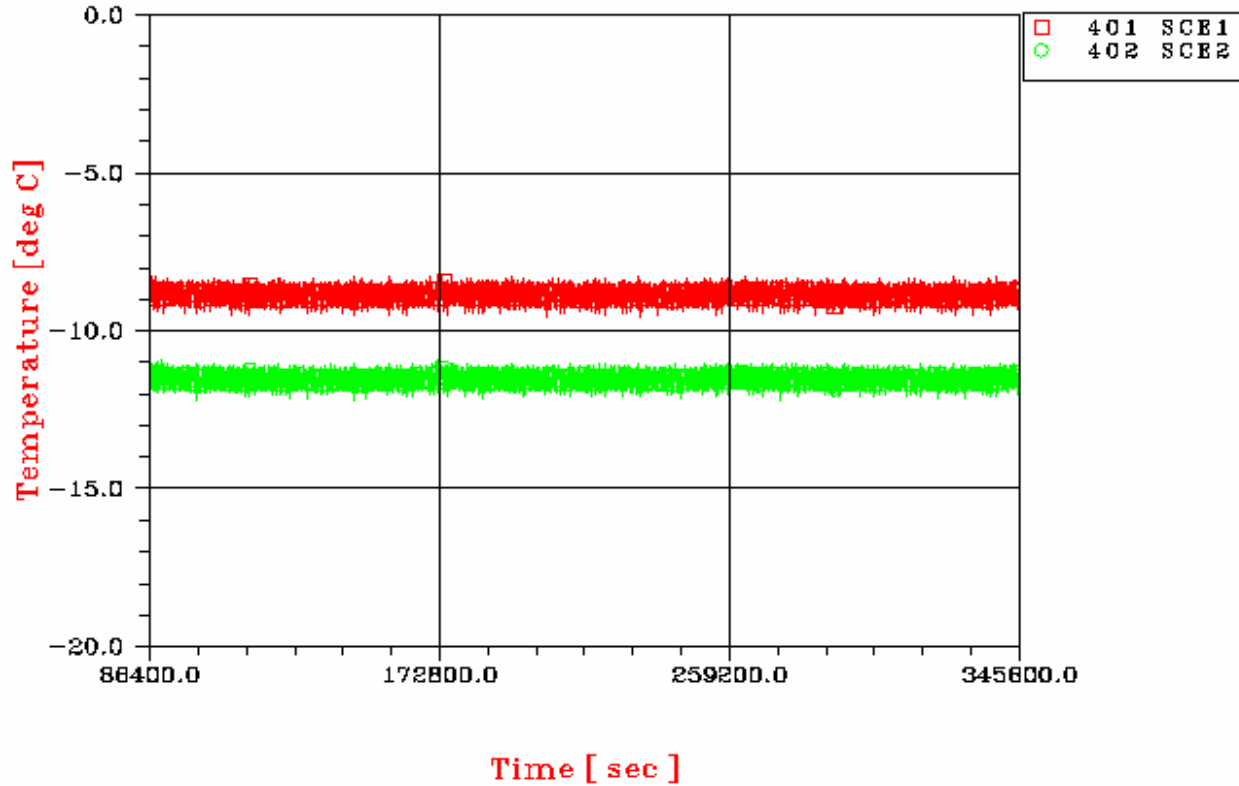

Controlled Distribution

REFERENCE : H-P-RP-AI-0040

DATE : 29/SEP/06

ISSUE : 06

Page : 305/405

PLANCK - CASE A3 BOL Mode3
SUBPLATFORM +X-X

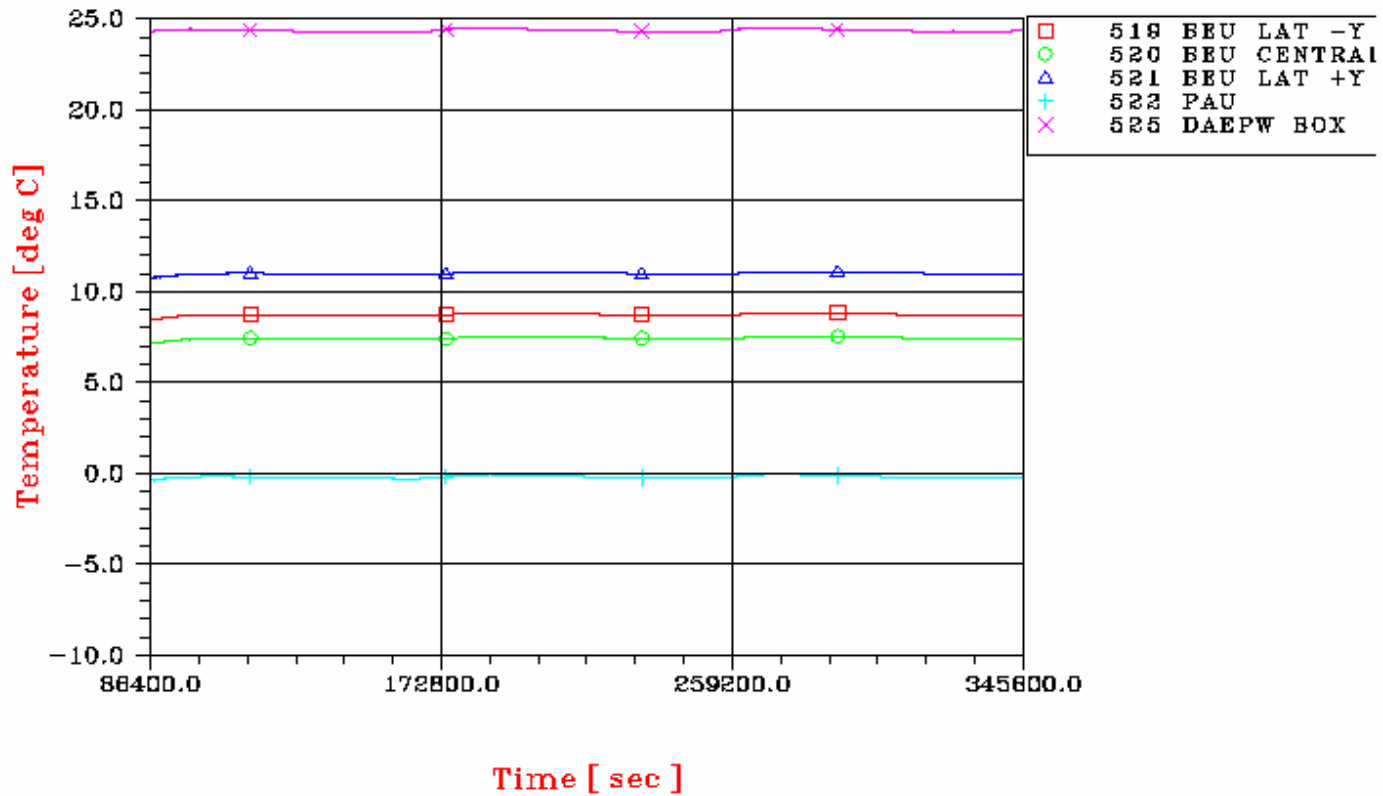

Controlled Distribution

REFERENCE : H-P-RP-AI-0040

DATE : 29/SEP/06

ISSUE : 06

Page : 306/405

PLANCK - CASE A3 BOL Mode3
LATERAL PANEL - Y

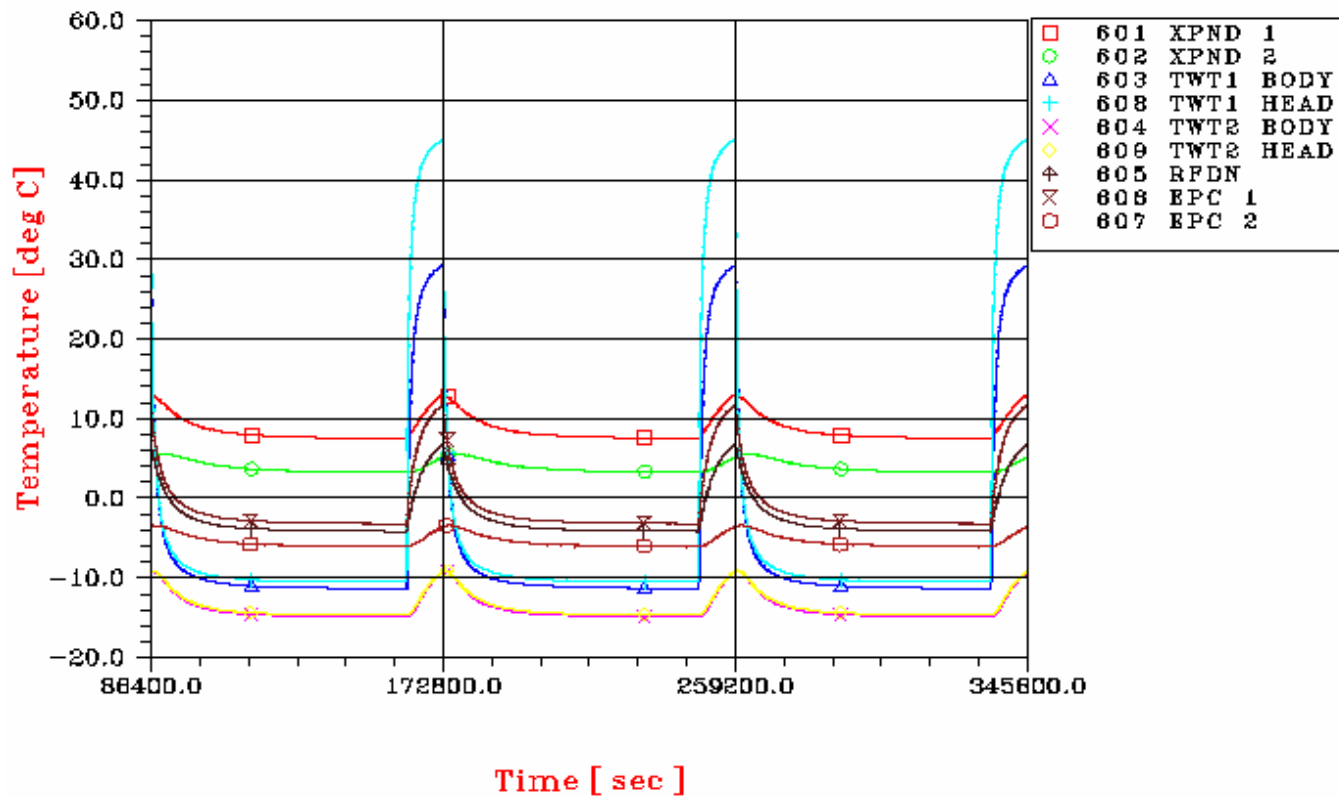

Controlled Distribution

REFERENCE : H-P-RP-AI-0040

DATE : 29/SEP/06

ISSUE : 06

Page : 307/405

PLANCK - CASE A3 BOL Mode3
LATERAL PANEL +Z-Y

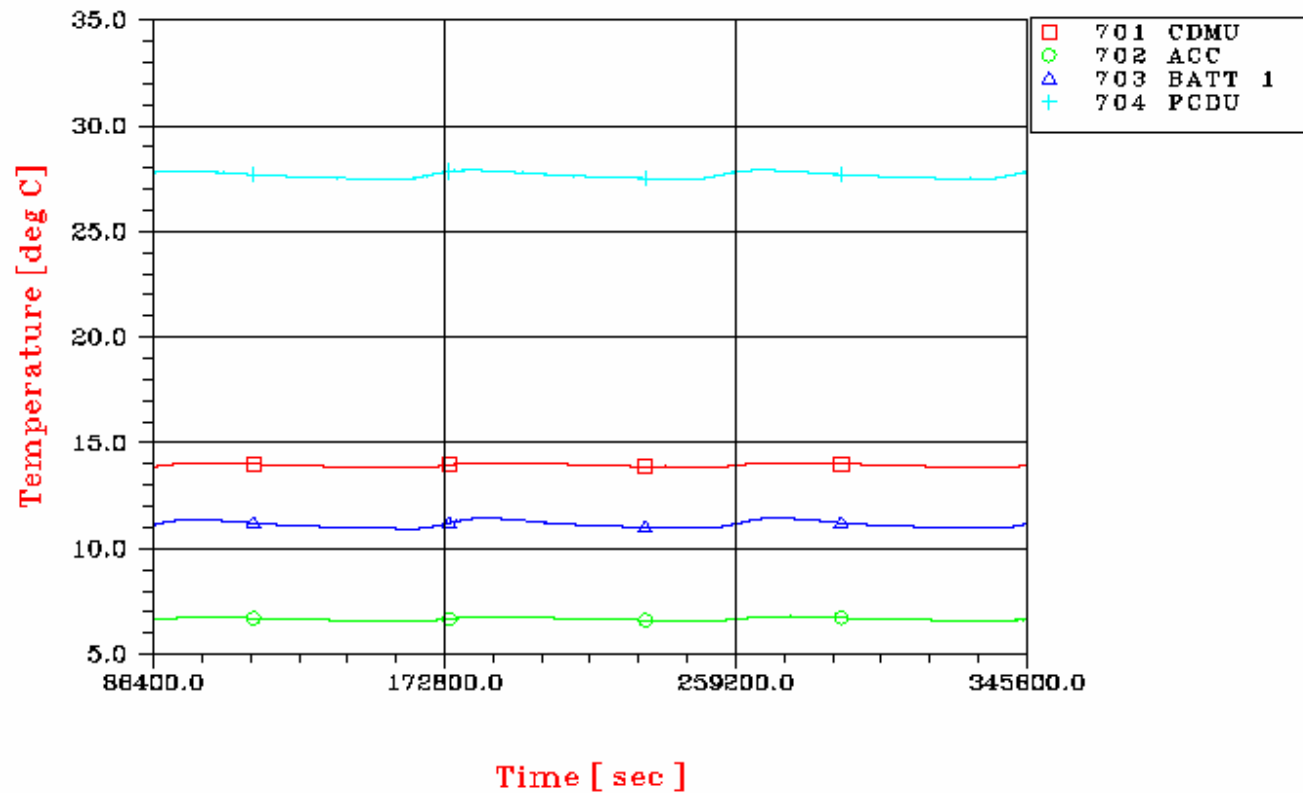

Controlled Distribution

REFERENCE : H-P-RP-AI-0040

DATE : 29/SEP/06

ISSUE : 06

Page : 308/405

PLANCK – CASE A3 BOL Mode3
SHEAR PANEL – CRS

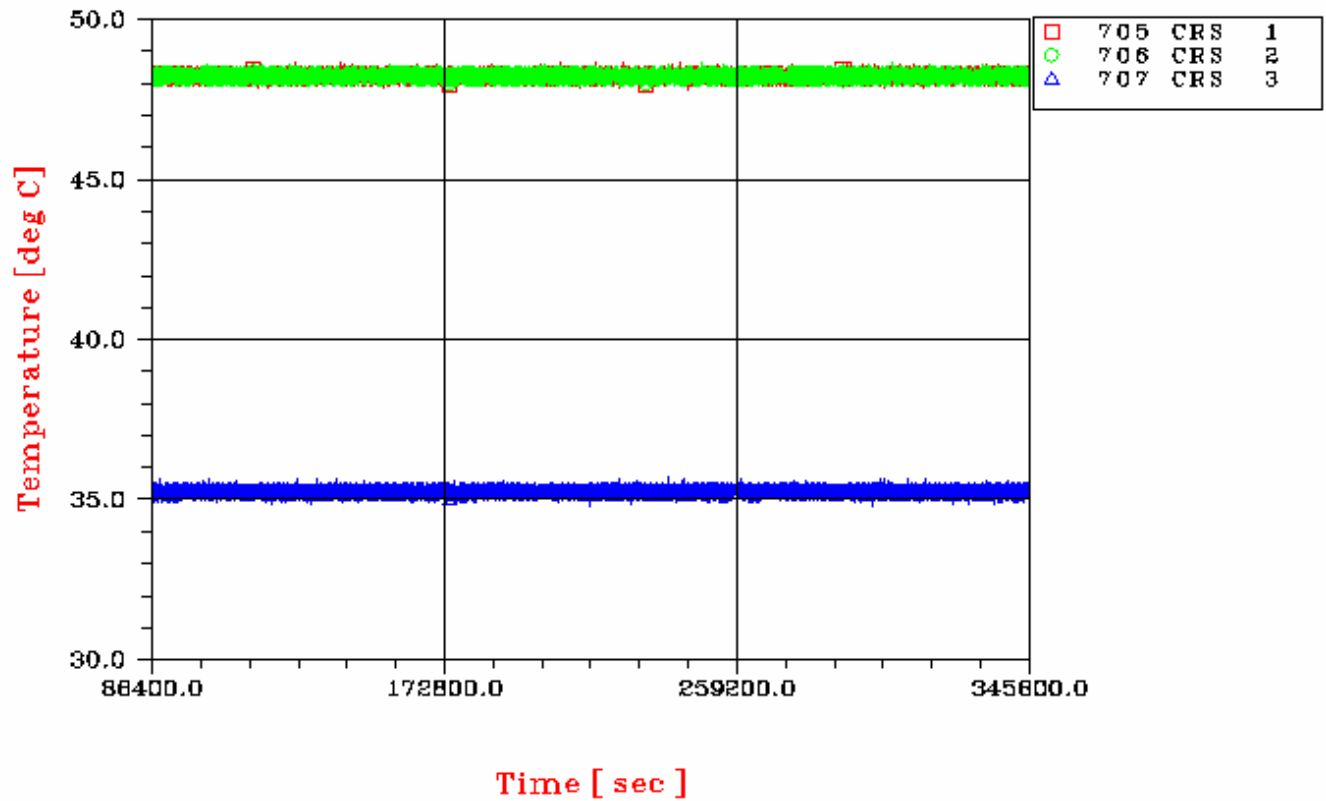

Controlled Distribution

REFERENCE : H-P-RP-AI-0040

DATE : 29/SEP/06

ISSUE : 06

Page : 309/405

PLANCK – CASE A3 BOL Mode3

SHEAR PANEL – CRS detail

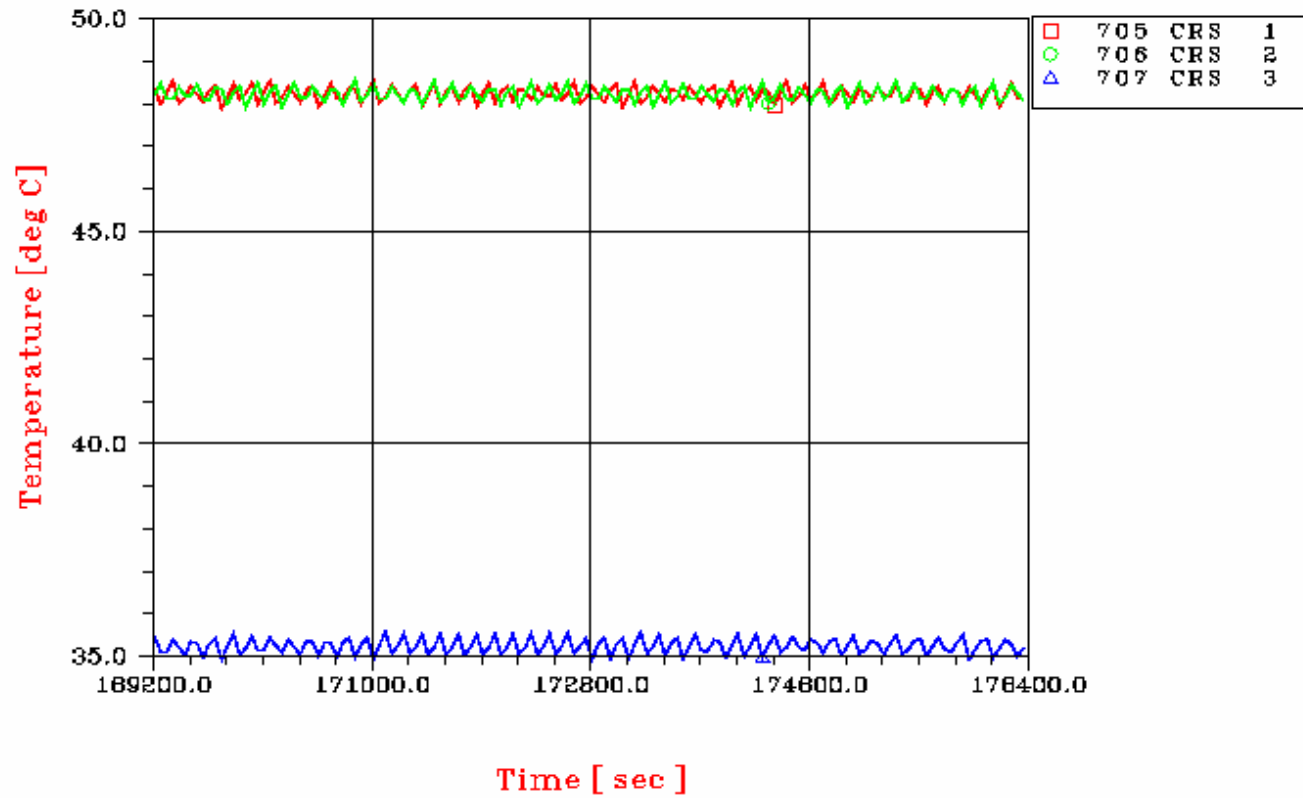

Controlled Distribution

REFERENCE : H-P-RP-AI-0040

DATE : 29/SEP/06

ISSUE : 06

Page : 310/405

PLANCK - CASE A3 BOL Mode3
PROPELLANT TANK

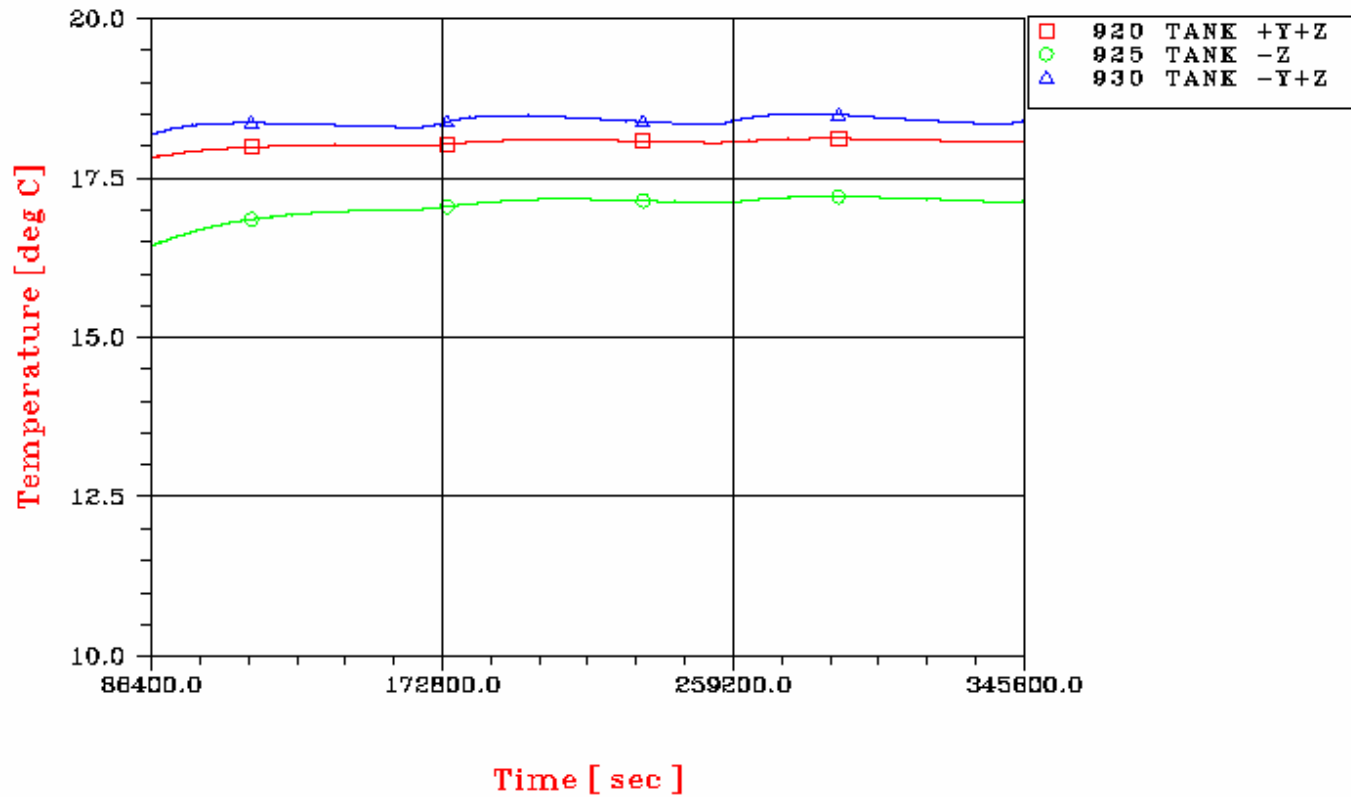

Controlled Distribution

REFERENCE : H-P-RP-AI-0040

DATE : 29/SEP/06

ISSUE : 06

Page : 311/405

PLANCK - CASE A3 BOL Mode3
HE TANK

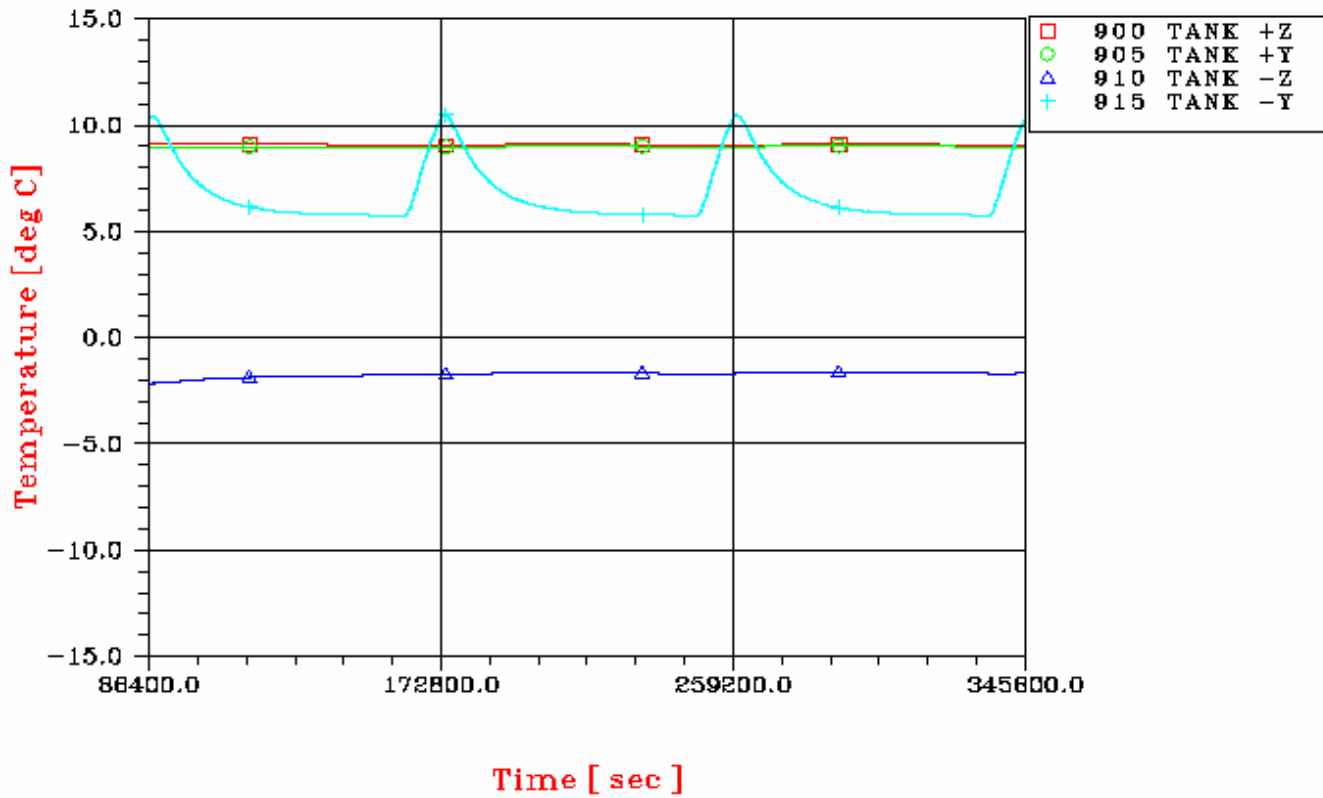

Controlled Distribution

REFERENCE : H-P-RP-AI-0040

DATE : 29/SEP/06

ISSUE : 06

Page : 312/405

PLANCK – CASE A3 BOL Mode3

SCC1 ON

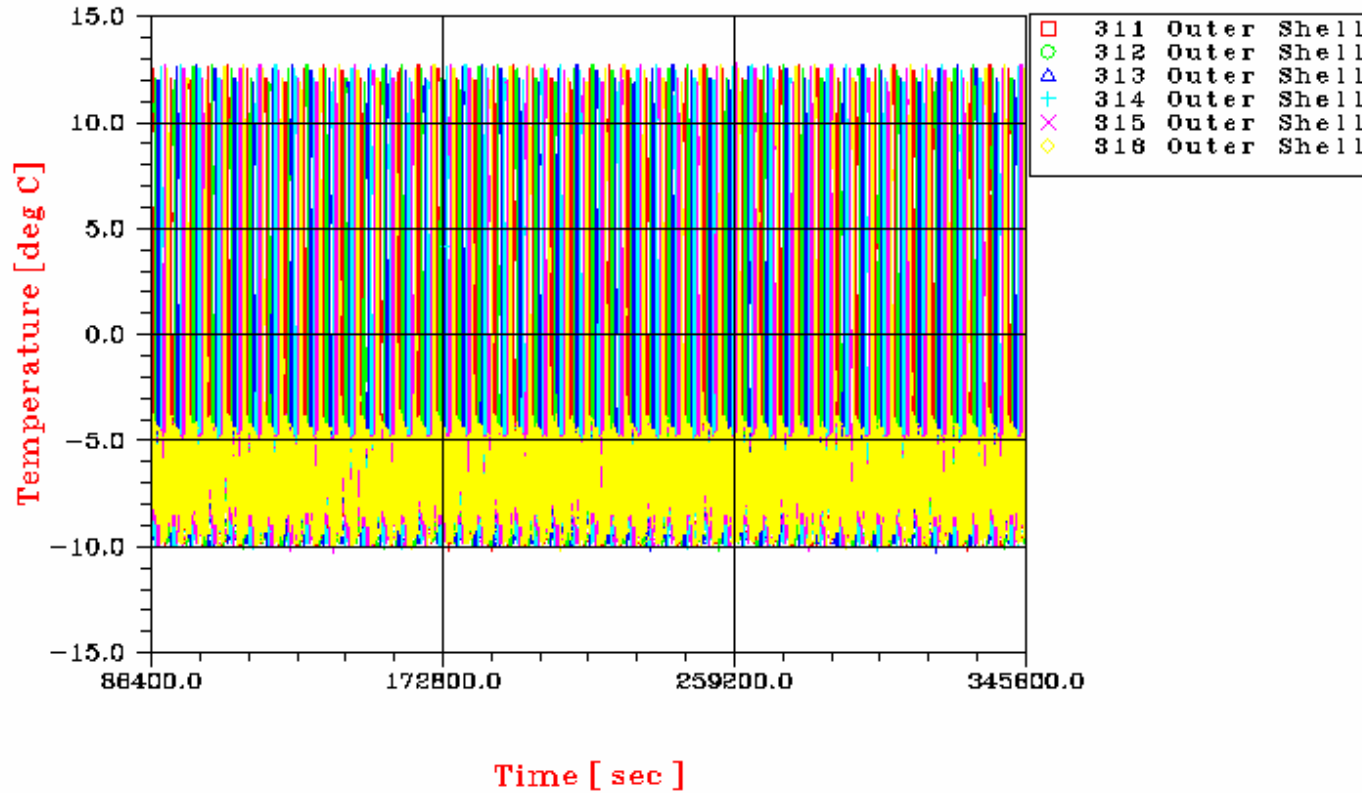

Controlled Distribution

REFERENCE : H-P-RP-AI-0040

DATE : 29/SEP/06

ISSUE : 06

Page : 313/405

PLANCK – CASE A3 BOL Mode3
SCC1 ON

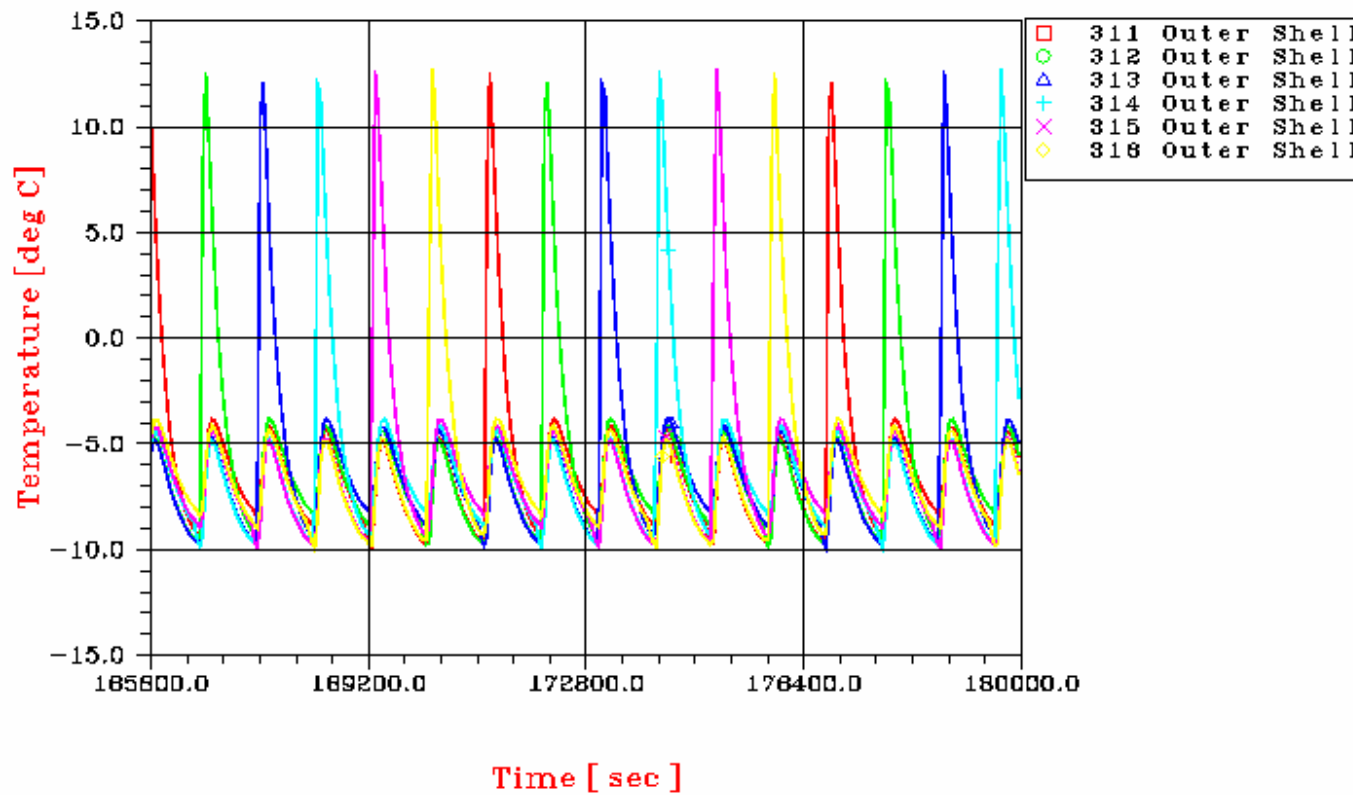

Controlled Distribution

REFERENCE : H-P-RP-AI-0040

DATE : 29/SEP/06

ISSUE : 06

Page : 314/405

PLANCK – CASE A3 BOL Mode3

SCC1

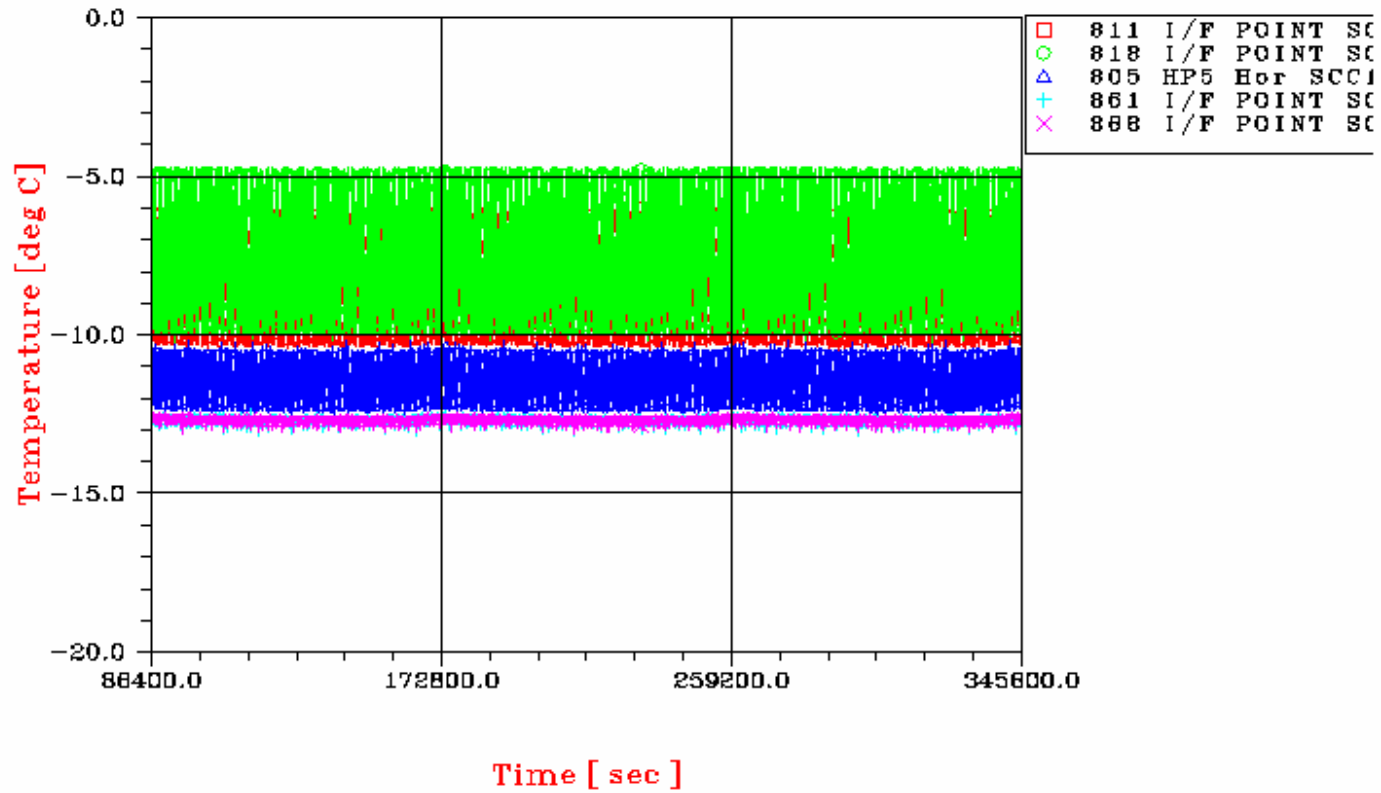

Controlled Distribution

REFERENCE : H-P-RP-AI-0040

DATE : 29/SEP/06

ISSUE : 06

Page : 315/405

PLANCK – CASE A3 BOL Mode3

SCC1

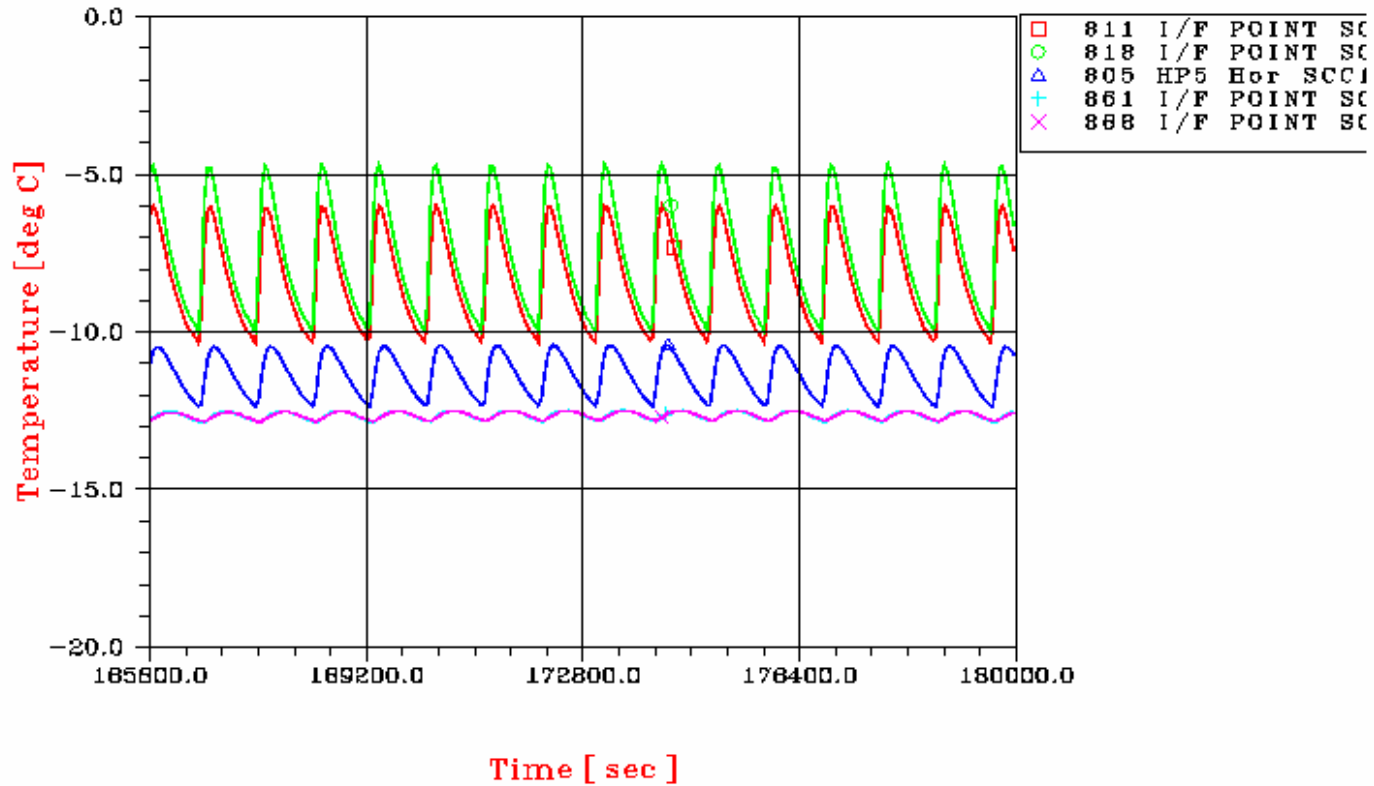

Controlled Distribution

REFERENCE : H-P-RP-AI-0040

DATE : 29/SEP/06

ISSUE : 06

Page : 316/405

PLANCK – CASE A3 BOL Mode3
SCC2 OFF

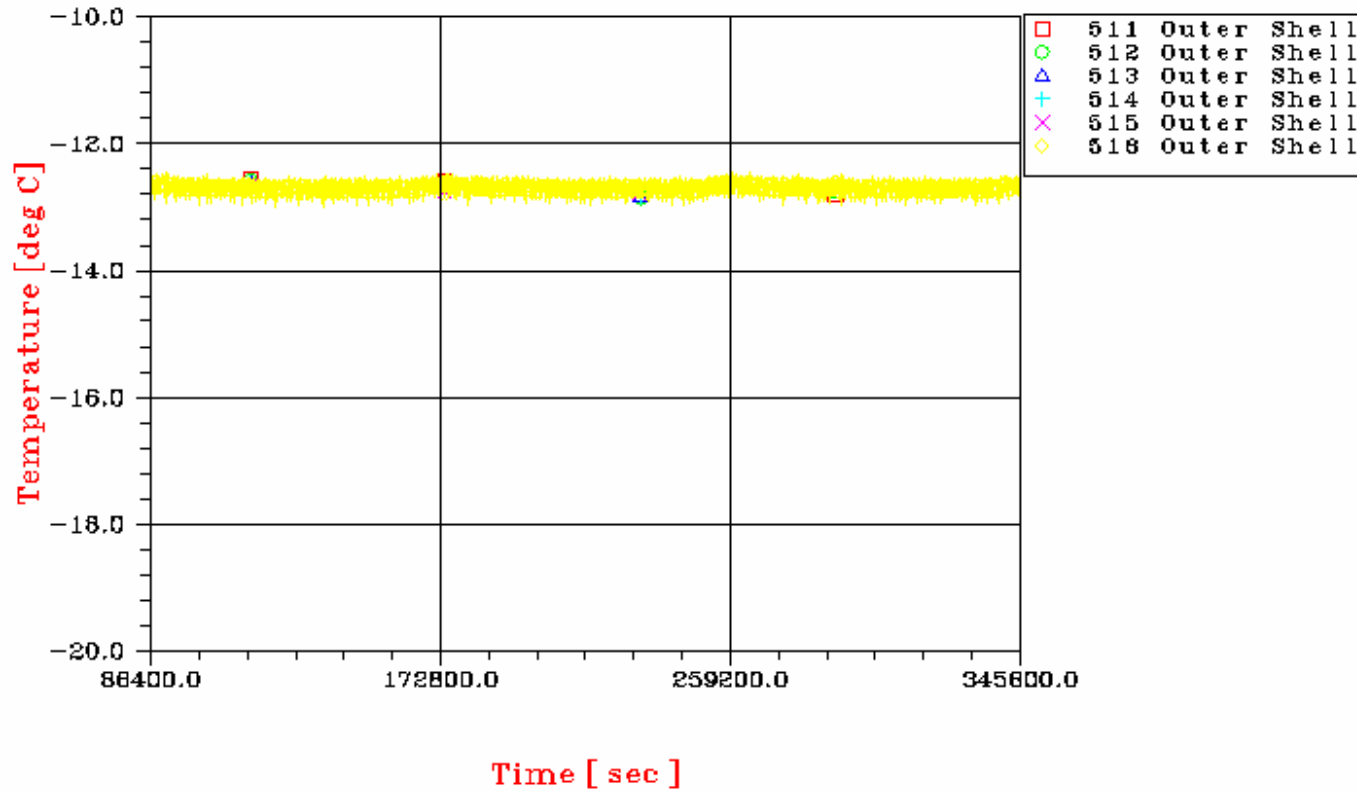

Controlled Distribution

REFERENCE : H-P-RP-AI-0040

DATE : 29/SEP/06

ISSUE : 06

Page : 317/405

PLANCK CASE A3 BOL Mode3

RCS line #32

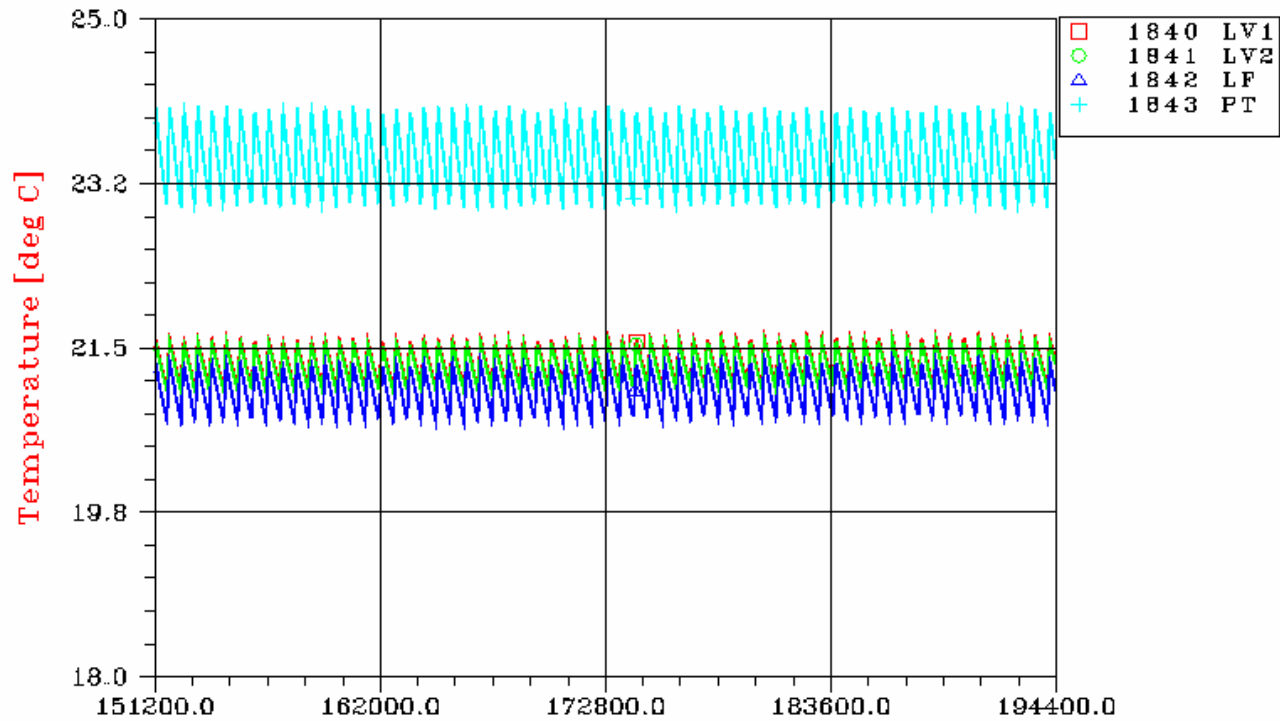

Controlled Distribution

REFERENCE : H-P-RP-AI-0040

DATE : 29/SEP/06

ISSUE : 06

Page : 318/405

PLANCK CASE A3 BOL Mode3

RCS line #33

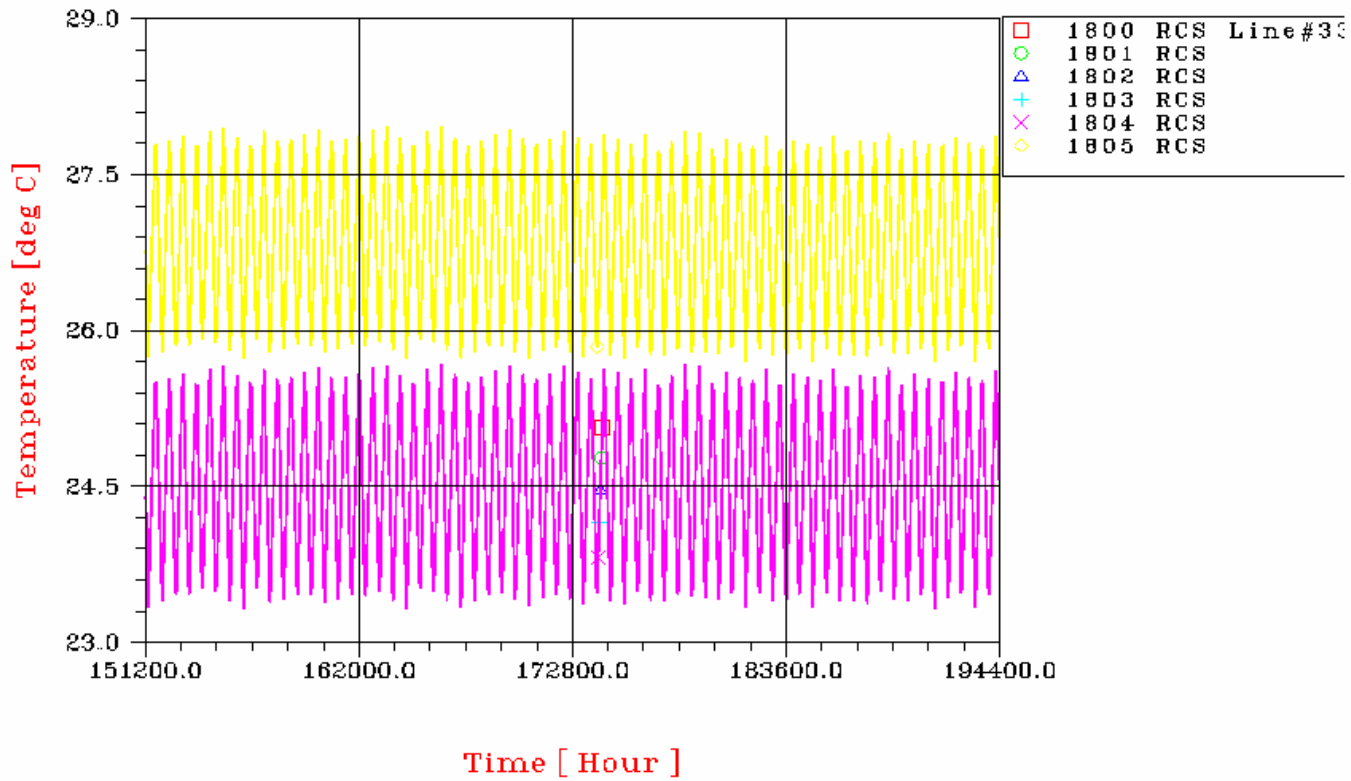

Controlled Distribution

REFERENCE : H-P-RP-AI-0040

DATE : 29/SEP/06

ISSUE : 06

Page : 319/405

PLANCK CASE A3 BOL Mode3

RCS line #33

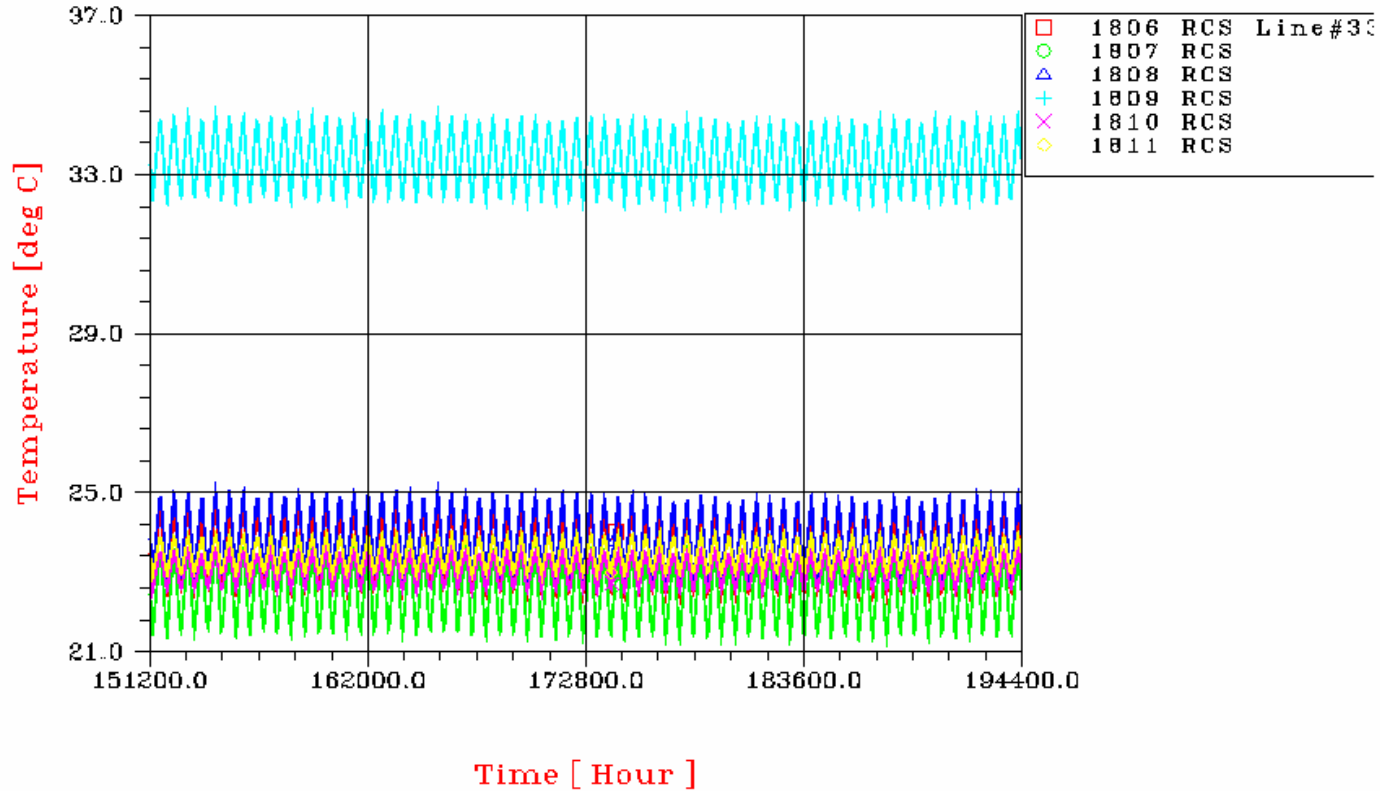

Controlled Distribution

REFERENCE : H-P-RP-AI-0040

DATE : 29/SEP/06

ISSUE : 06

Page : 320/405

PLANCK CASE A3 BOL Mode3

RCS line #33

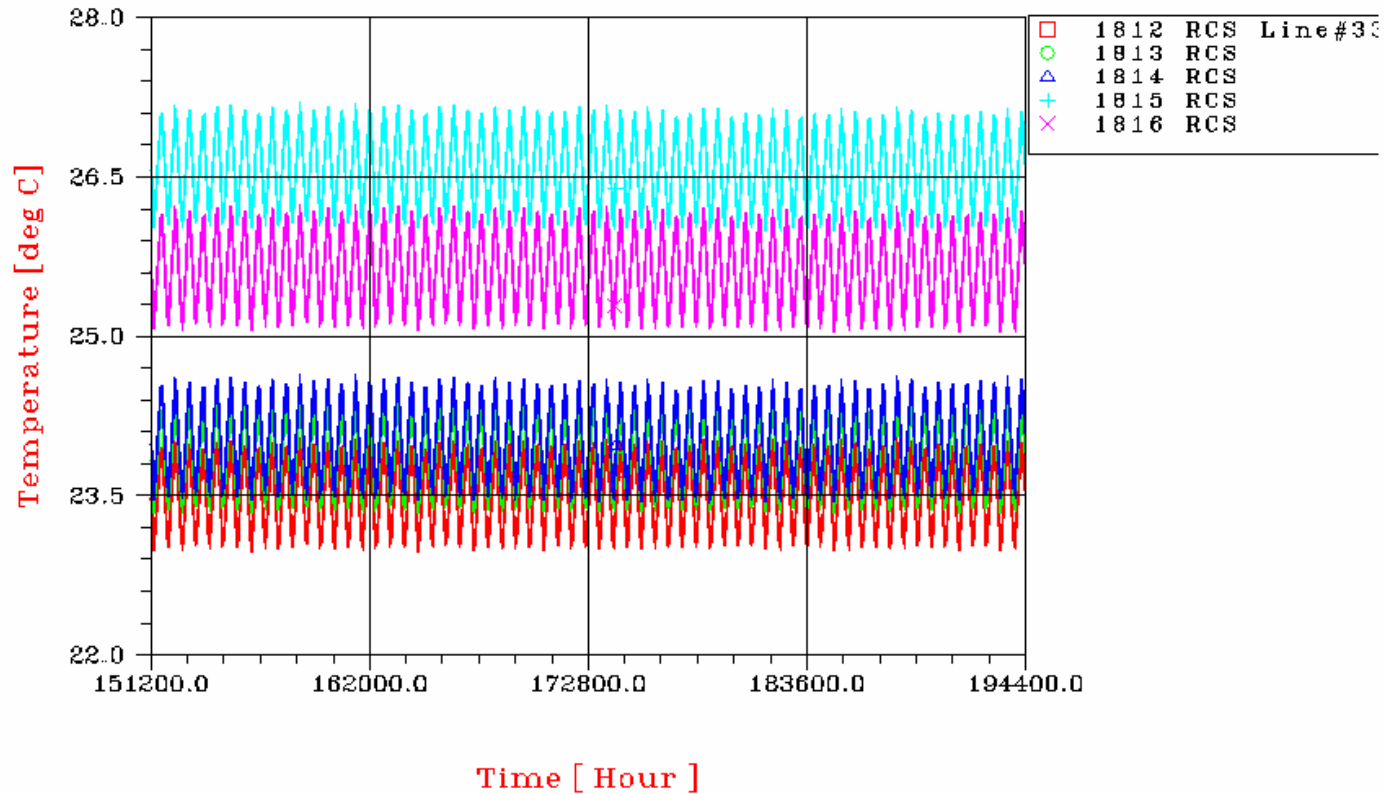

Controlled Distribution

REFERENCE : H-P-RP-AI-0040

DATE : 29/SEP/06

ISSUE : 06

Page : 321/405

PLANCK CASE A3 BOL Mode3

RCS line #34

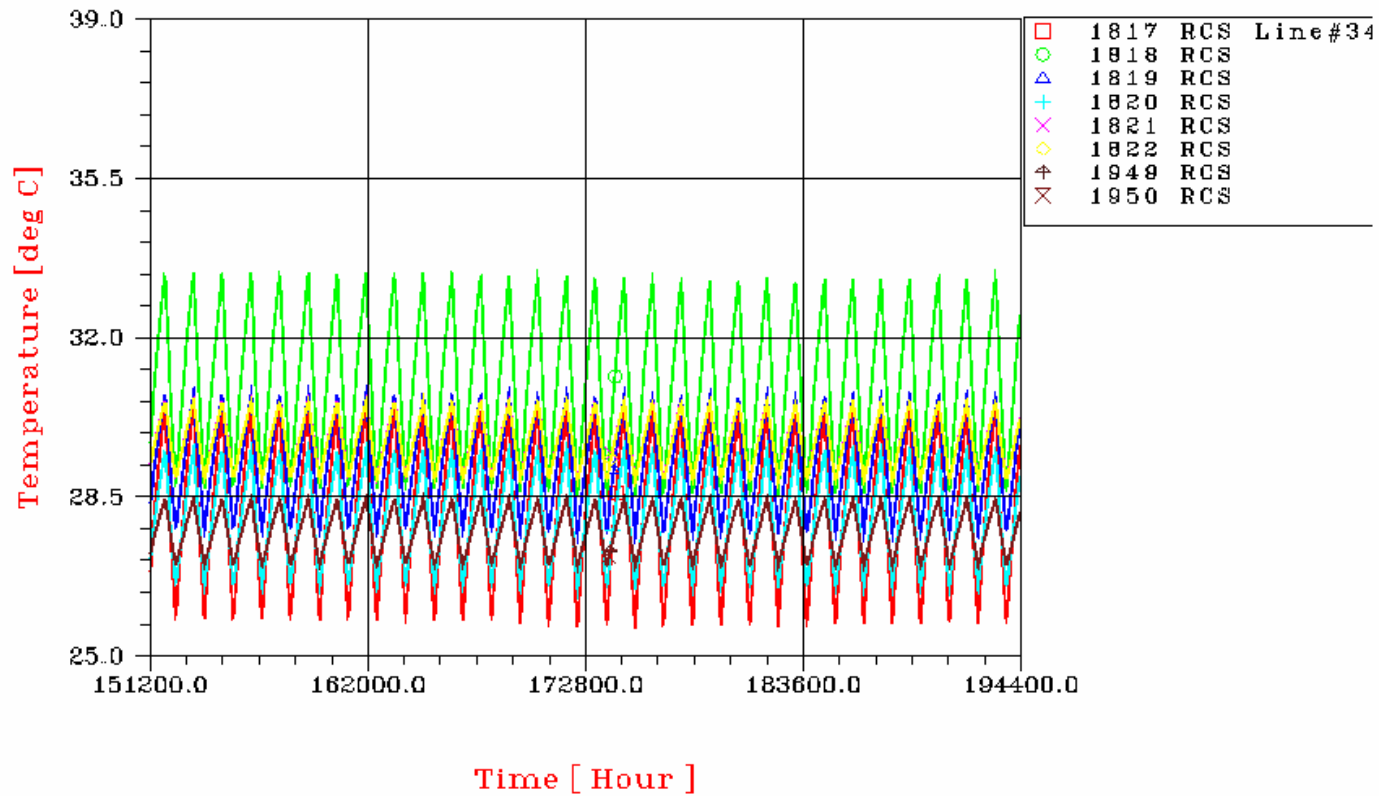

Controlled Distribution

REFERENCE : H-P-RP-AI-0040

DATE : 29/SEP/06

ISSUE : 06

Page : 322/405

PLANCK CASE A3 BOL Mode3

RCS line #34

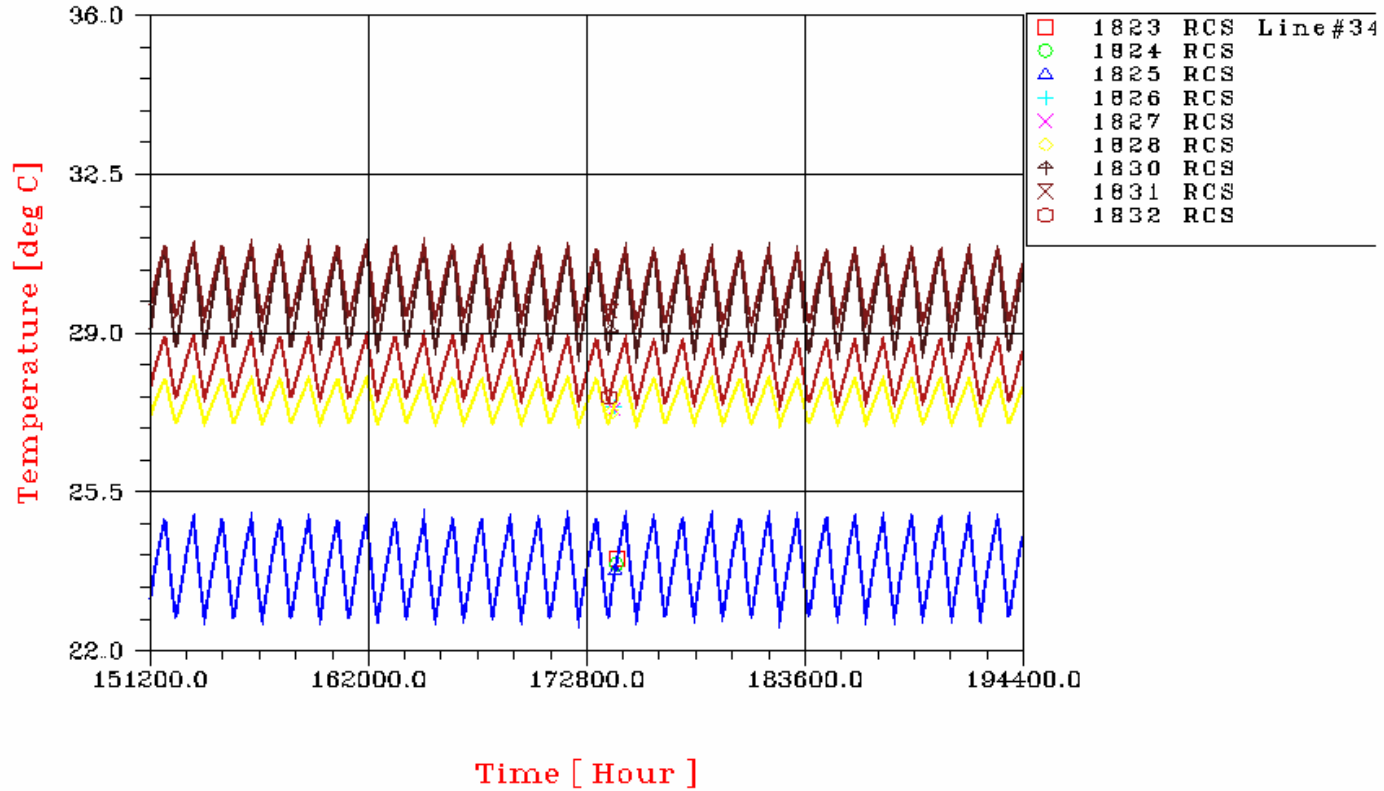

Controlled Distribution

REFERENCE : H-P-RP-AI-0040

DATE : 29/SEP/06

ISSUE : 06

Page : 323/405

PLANCK CASE A3 BOL Mode3

RCS line #34

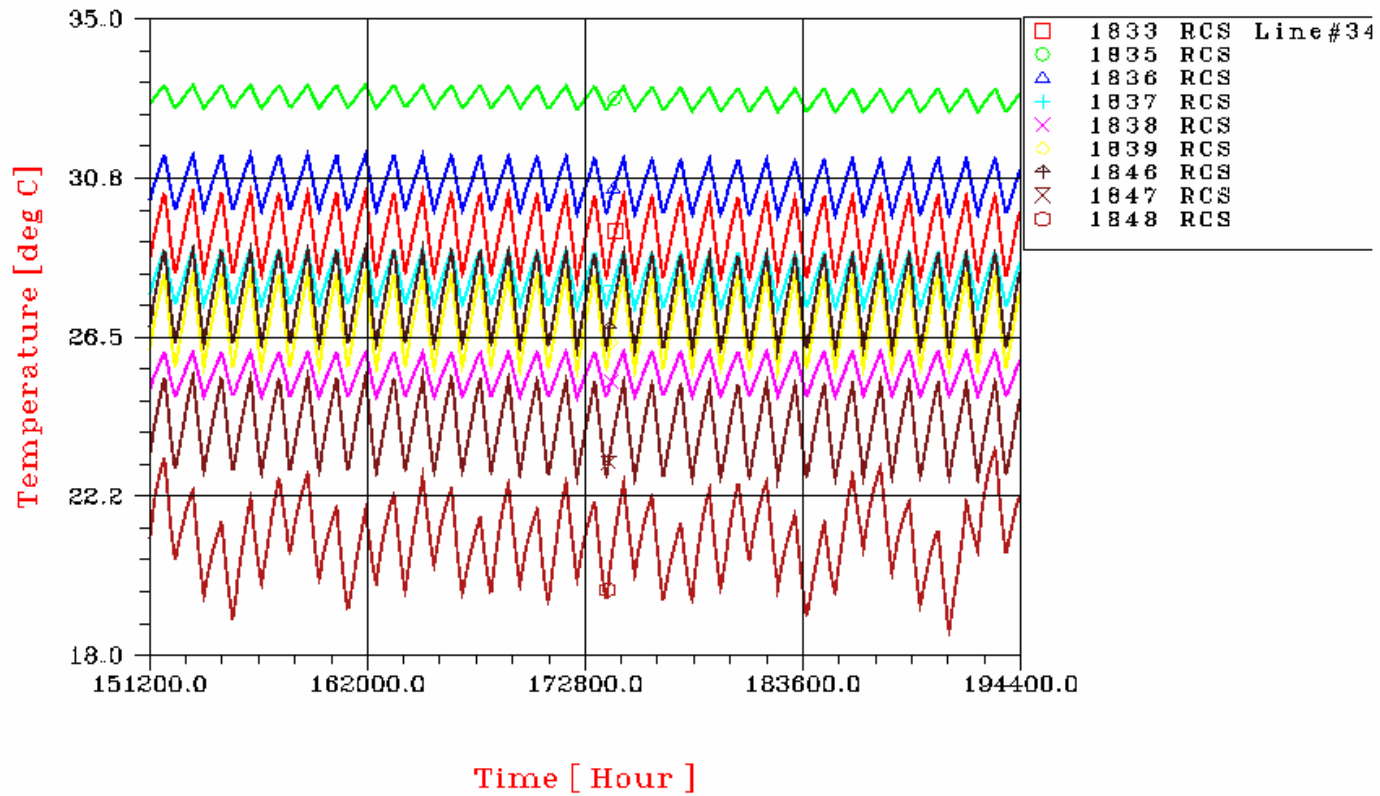

Controlled Distribution

REFERENCE : H-P-RP-AI-0040

DATE : 29/SEP/06

ISSUE : 06

Page : 324/405

PLANCK CASE A3 BOL Mode3

RCS line #46

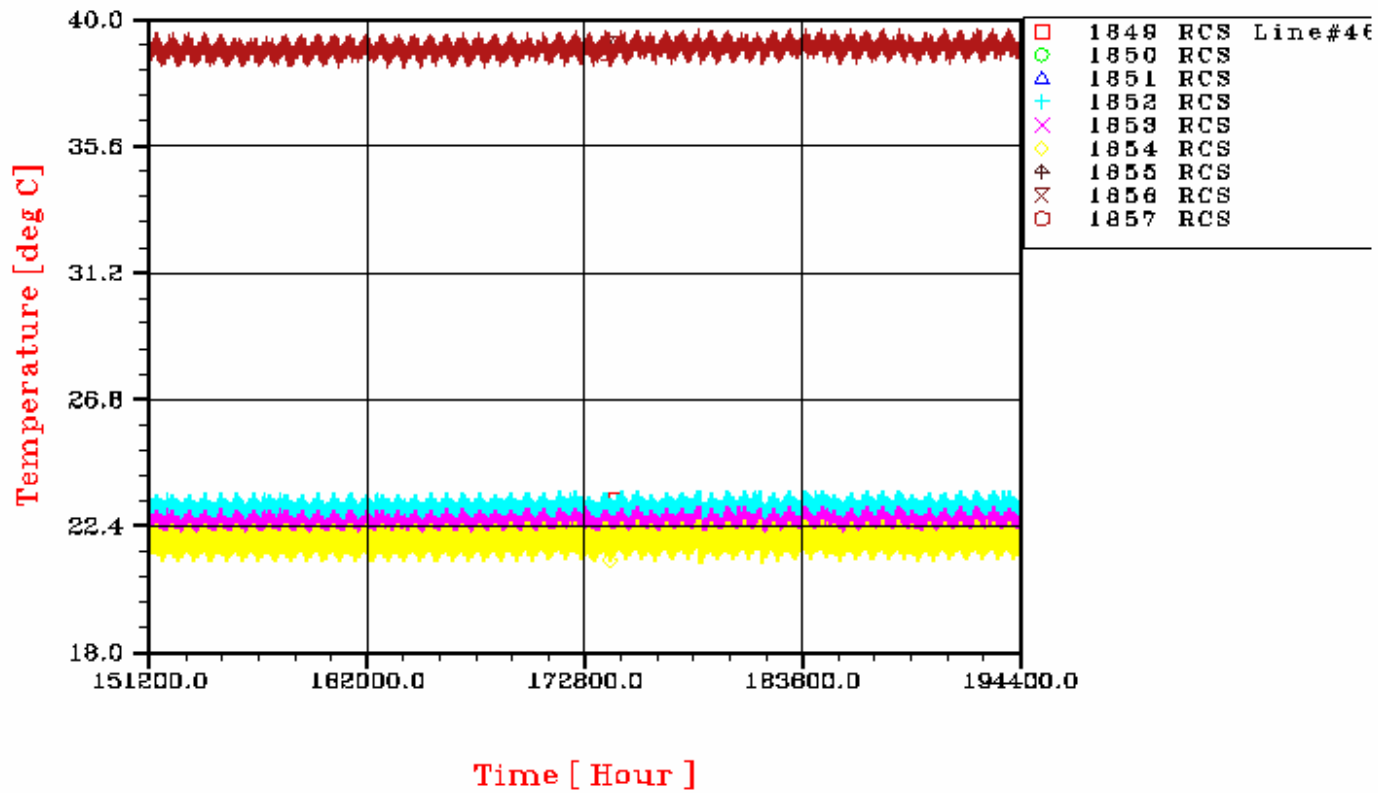

Controlled Distribution

REFERENCE : H-P-RP-AI-0040

DATE : 29/SEP/06

ISSUE : 06

Page : 325/405

PLANCK CASE A3 BOL Mode3

RCS line #46

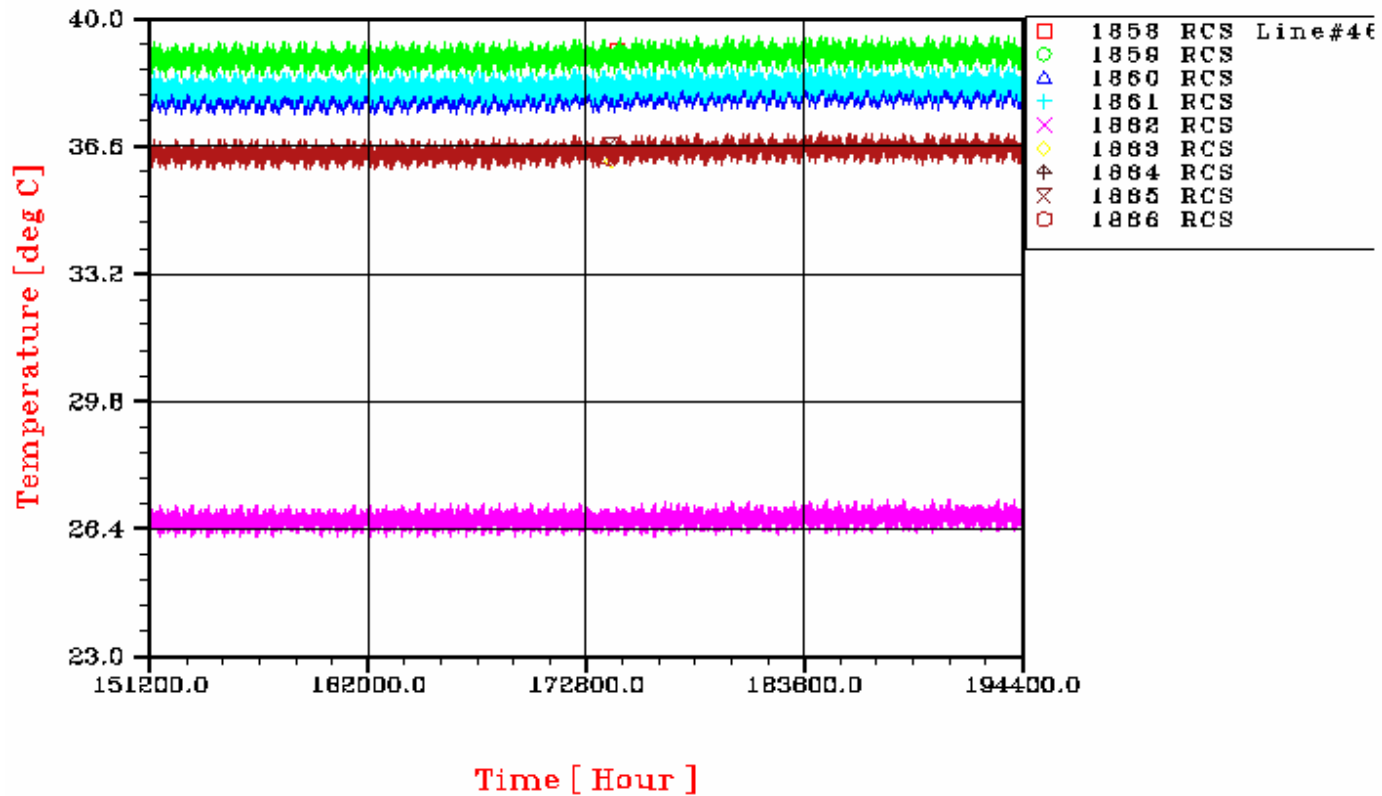

Controlled Distribution

REFERENCE : H-P-RP-AI-0040

DATE : 29/SEP/06

ISSUE : 06

Page : 326/405

PLANCK CASE A3 BOL Mode3

RCS line #46

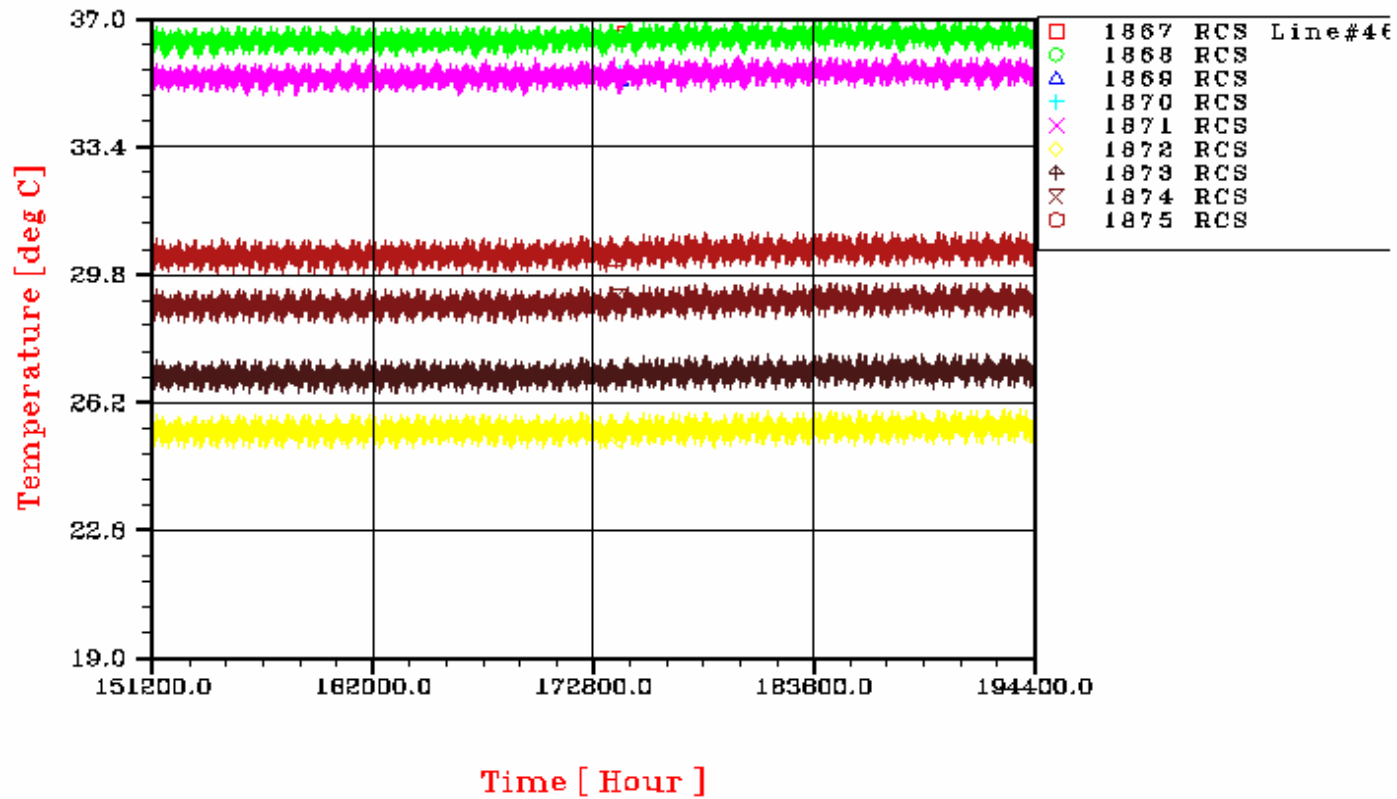

Controlled Distribution

REFERENCE : H-P-RP-AI-0040

DATE : 29/SEP/06

ISSUE : 06

Page : 327/405

PLANCK CASE A3 BOL Mode3

RCS line #46

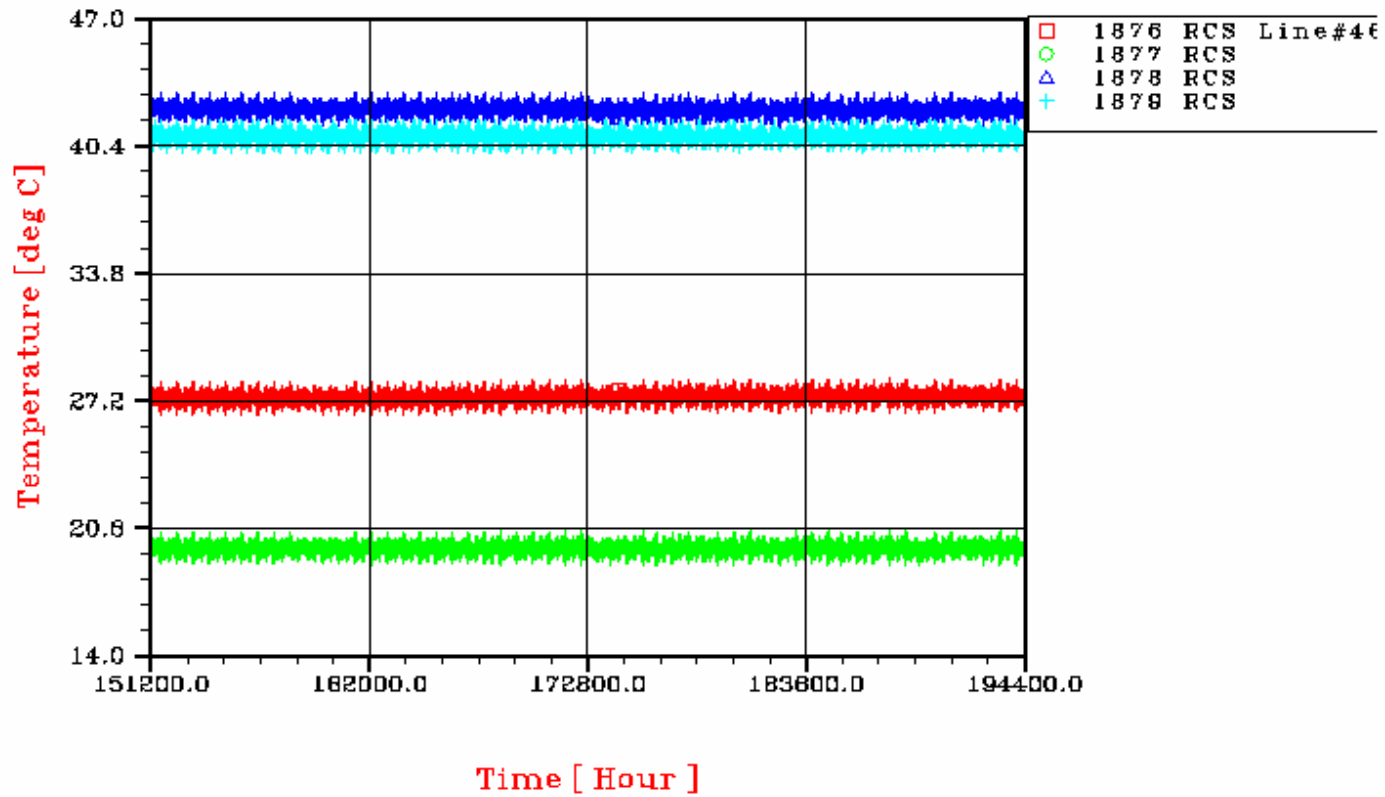

Controlled Distribution

REFERENCE : H-P-RP-AI-0040

DATE : 29/SEP/06

ISSUE : 06

Page : 328/405

PLANCK CASE A3 BOL Mode3

RCS line #47

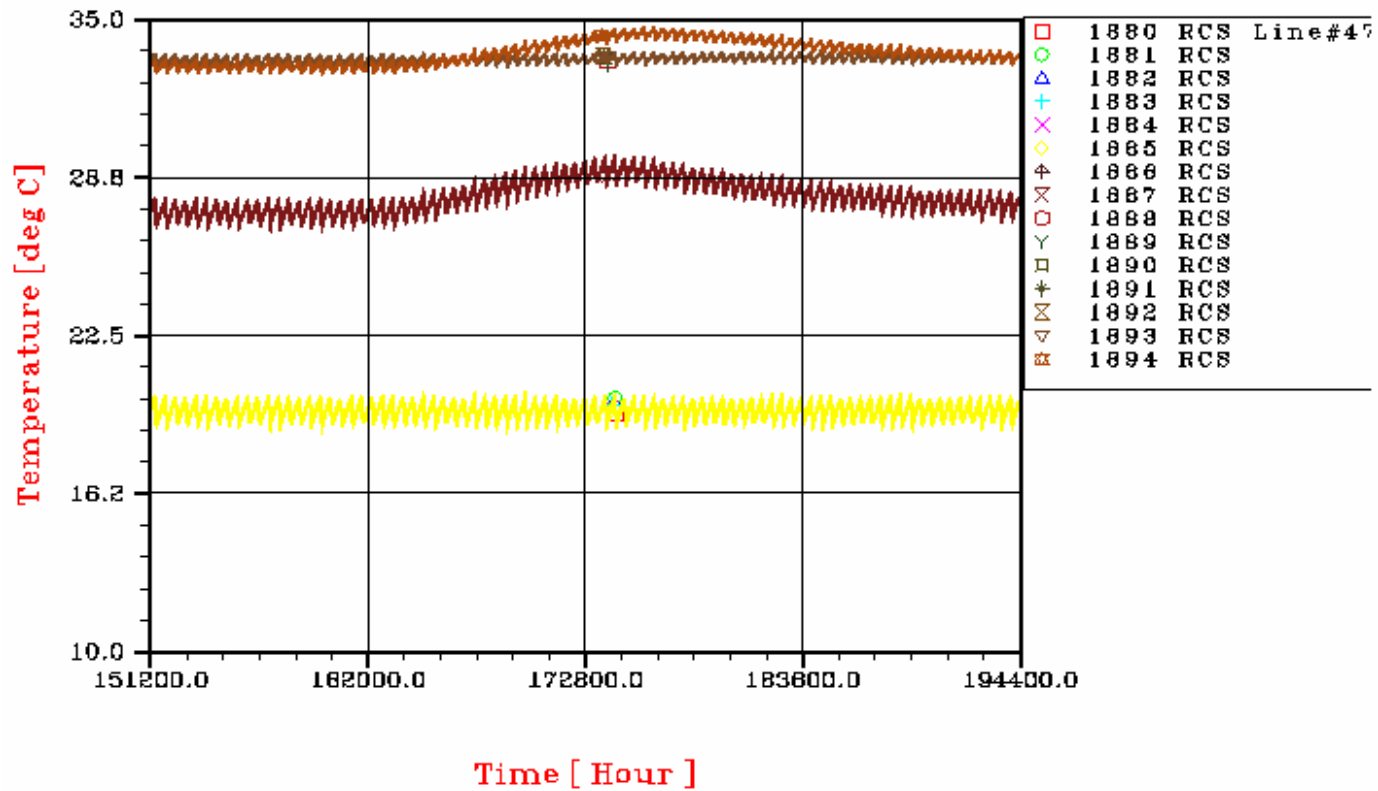

Controlled Distribution

REFERENCE : H-P-RP-AI-0040

DATE : 29/SEP/06

ISSUE : 06

Page : 329/405

PLANCK CASE A3 BOL Mode3

RCS line #47

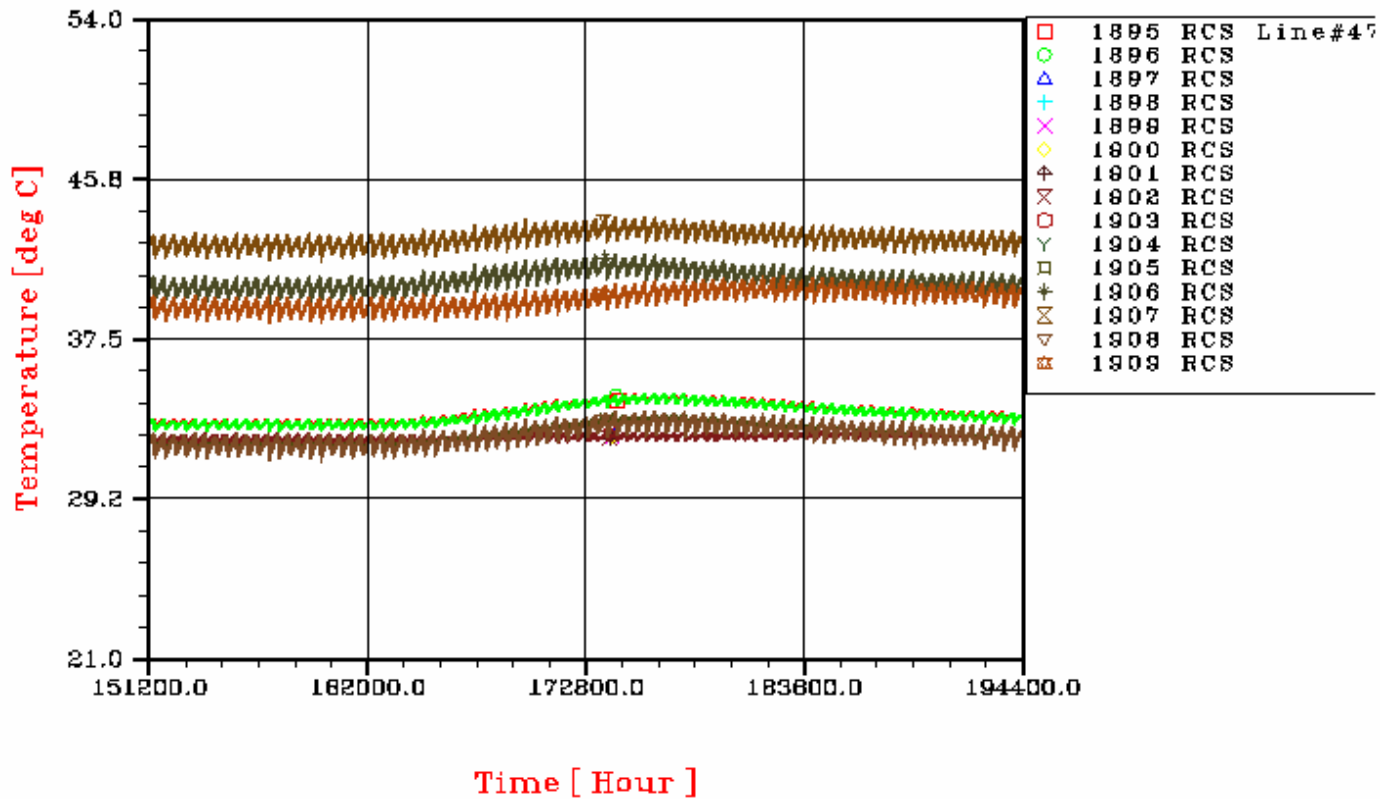

Controlled Distribution

REFERENCE : H-P-RP-AI-0040

DATE : 29/SEP/06

ISSUE : 06

Page : 330/405

PLANCK CASE A3 BOL Mode3

RCS line #47

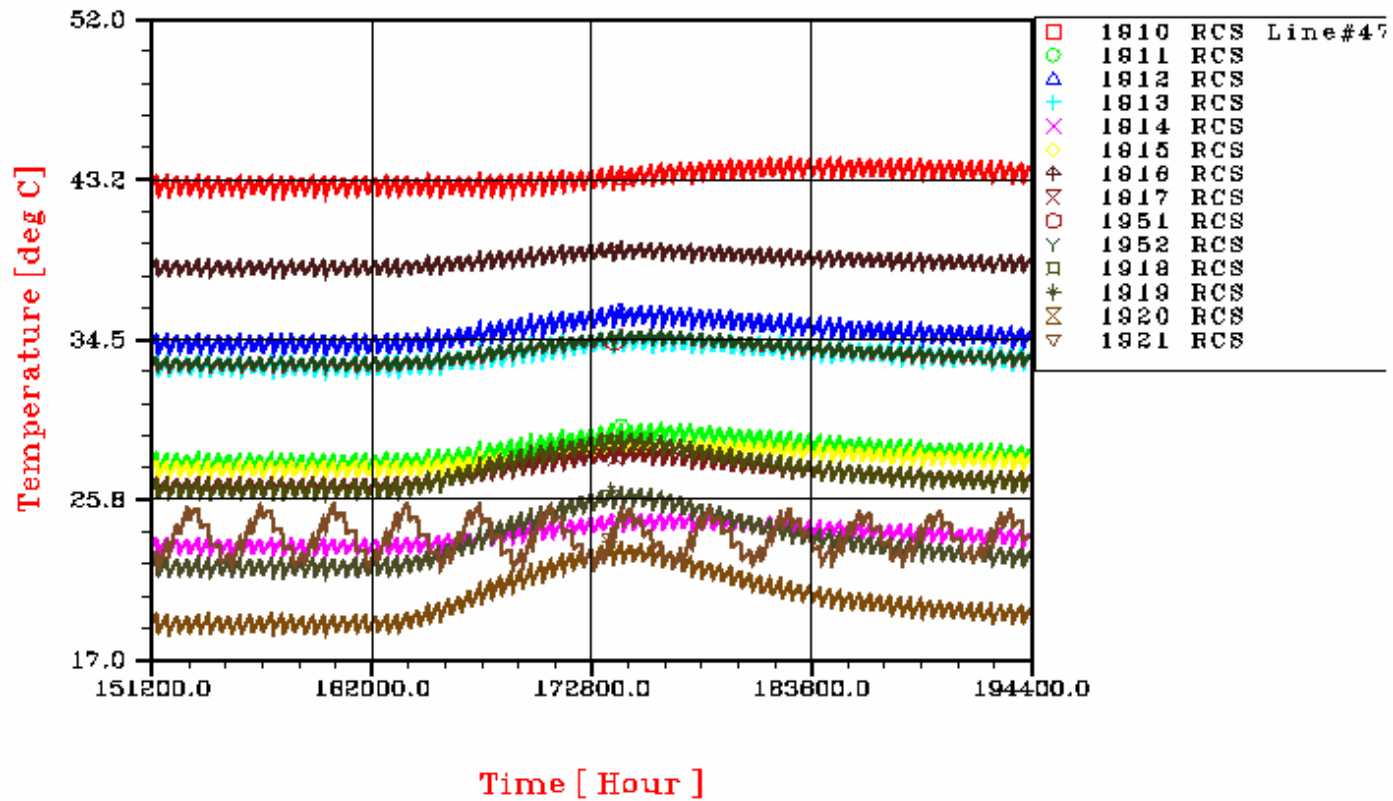

Controlled Distribution

REFERENCE : H-P-RP-AI-0040

DATE : 29/SEP/06

ISSUE : 06

Page : 331/405

PLANCK CASE A3 BOL Mode3

RCS line #48

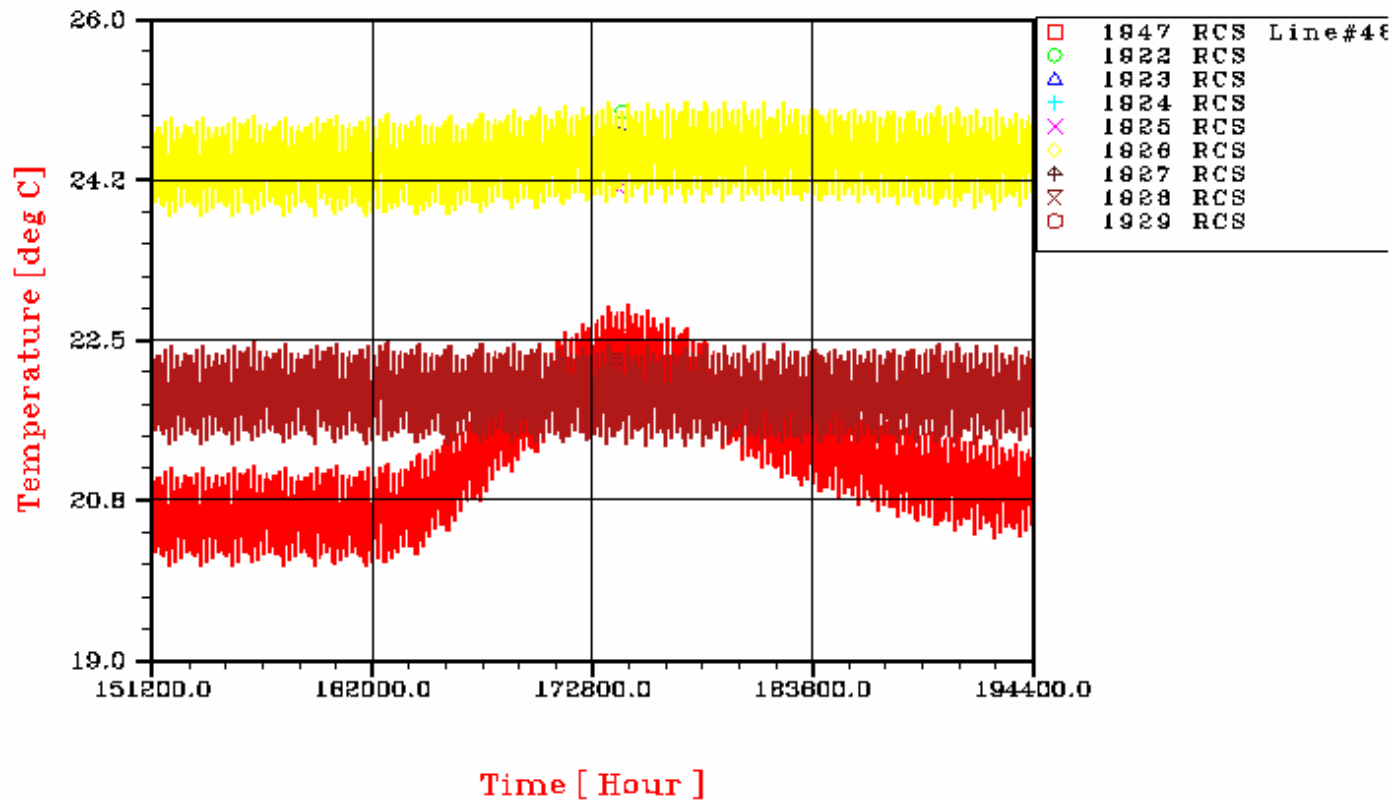

Controlled Distribution

REFERENCE : H-P-RP-AI-0040

DATE : 29/SEP/06

ISSUE : 06

Page : 332/405

PLANCK CASE A3 BOL Mode3

RCS line #48

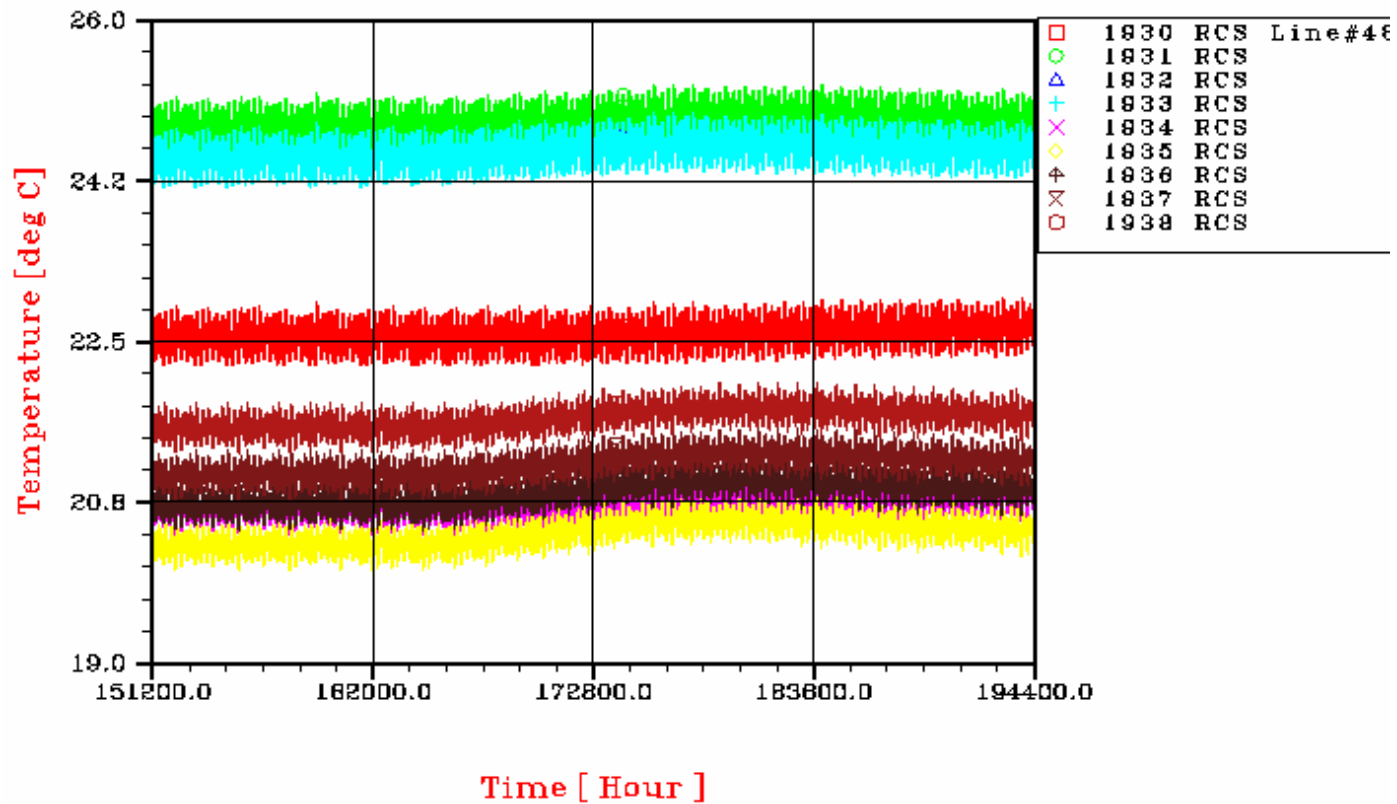

Controlled Distribution

REFERENCE : H-P-RP-AI-0040

DATE : 29/SEP/06

ISSUE : 06

Page : 333/405

PLANCK CASE A3 BOL Mode3

RCS line #48

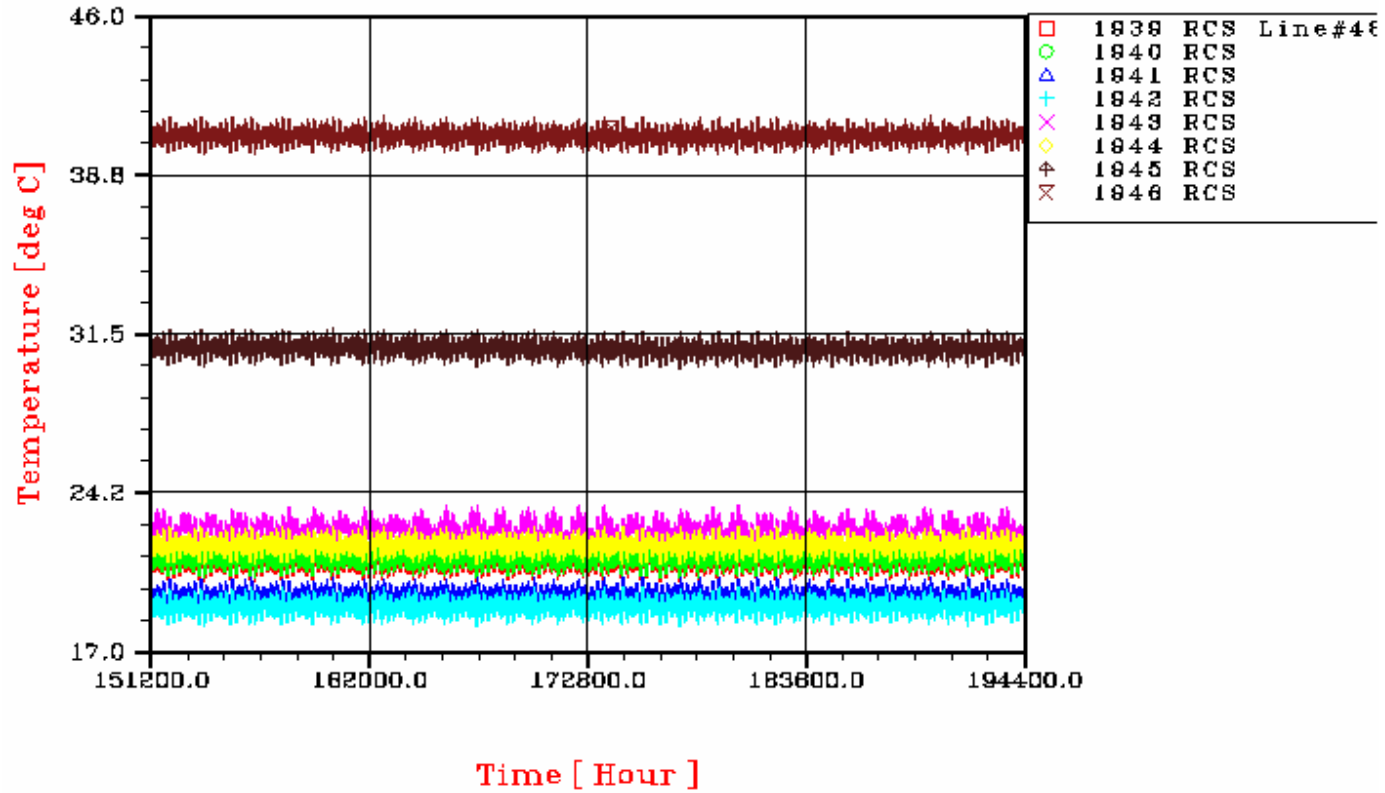

Controlled Distribution

REFERENCE : H-P-RP-AI-0040

DATE : 29/SEP/06

ISSUE : 06

Page : 334/405

11.2 PLANCK: PLOTS OF TRANSIENT NOMINAL ANALYSIS CASE B2

In the following figures, the temperature plots of the transient nominal analysis concerning the satellite in EOL condition case with SCC2 On are presented.

Controlled Distribution

REFERENCE : H-P-RP-AI-0040

DATE : 29/SEP/06

ISSUE : 06

Page : 335/405

**PLANCK - CASE B2 EOL SCC2 ON
LATERAL PANEL +Z**

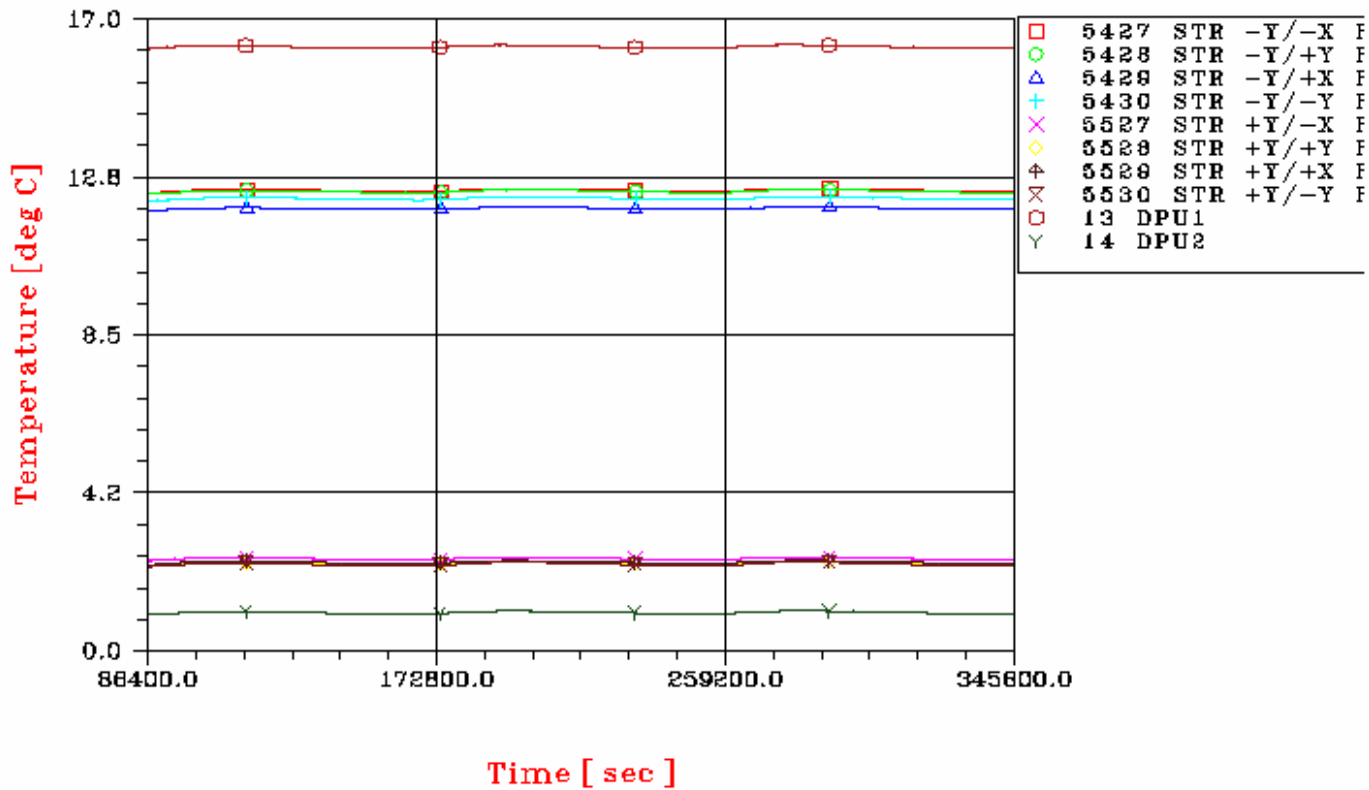

Controlled Distribution

REFERENCE : H-P-RP-AI-0040

DATE : 29/SEP/06

ISSUE : 06

Page : 336/405

**PLANCK – CASE B2 EOL SCC2 ON
LATERAL PANEL +Z+Y**

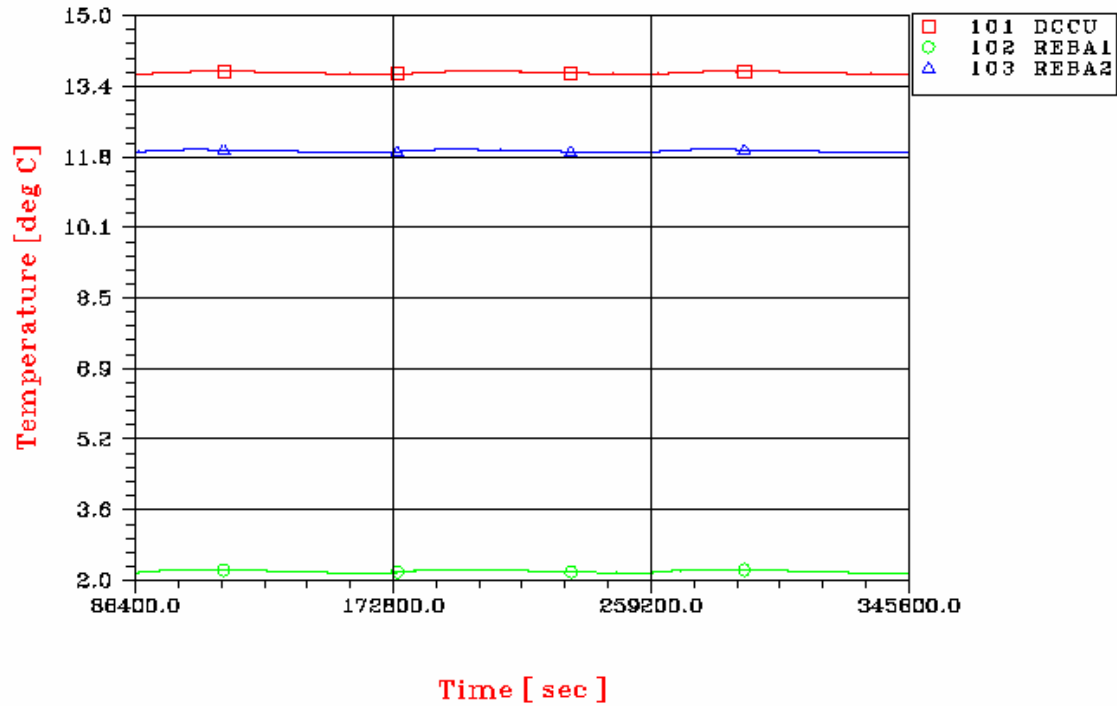

Controlled Distribution

REFERENCE : H-P-RP-AI-0040

DATE : 29/SEP/06

ISSUE : 06

Page : 337/405

**PLANCK – CASE B2 EOL SCC2 ON
SHEAR PANEL – FOG/CRU**

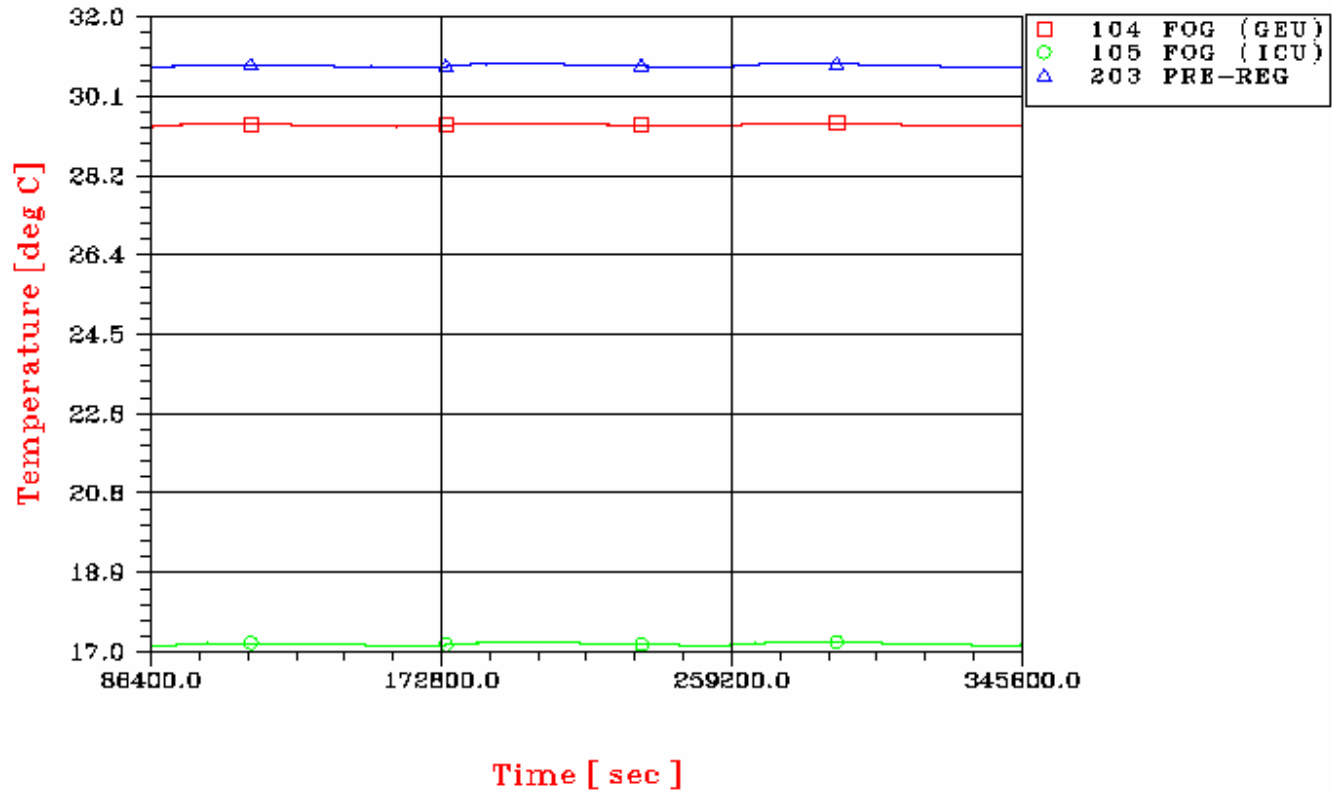

Controlled Distribution

REFERENCE : H-P-RP-AI-0040

DATE : 29/SEP/06

ISSUE : 06

Page : 338/405

**PLANCK - CASE B2 EOL SCC2 ON
LATERAL PANEL +Y**

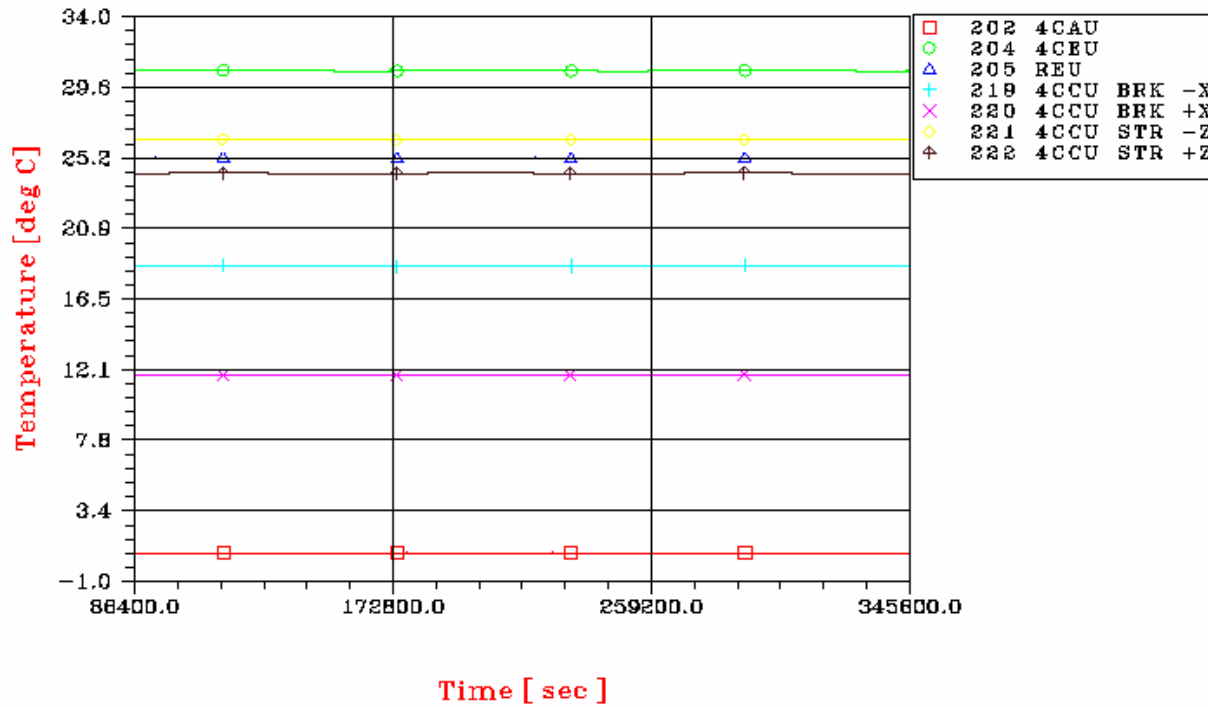

Controlled Distribution

REFERENCE : H-P-RP-AI-0040

DATE : 29/SEP/06

ISSUE : 06

Page : 339/405

**PLANCK – CASE B2 EOL SCC2 ON
LATERAL PANEL – Z**

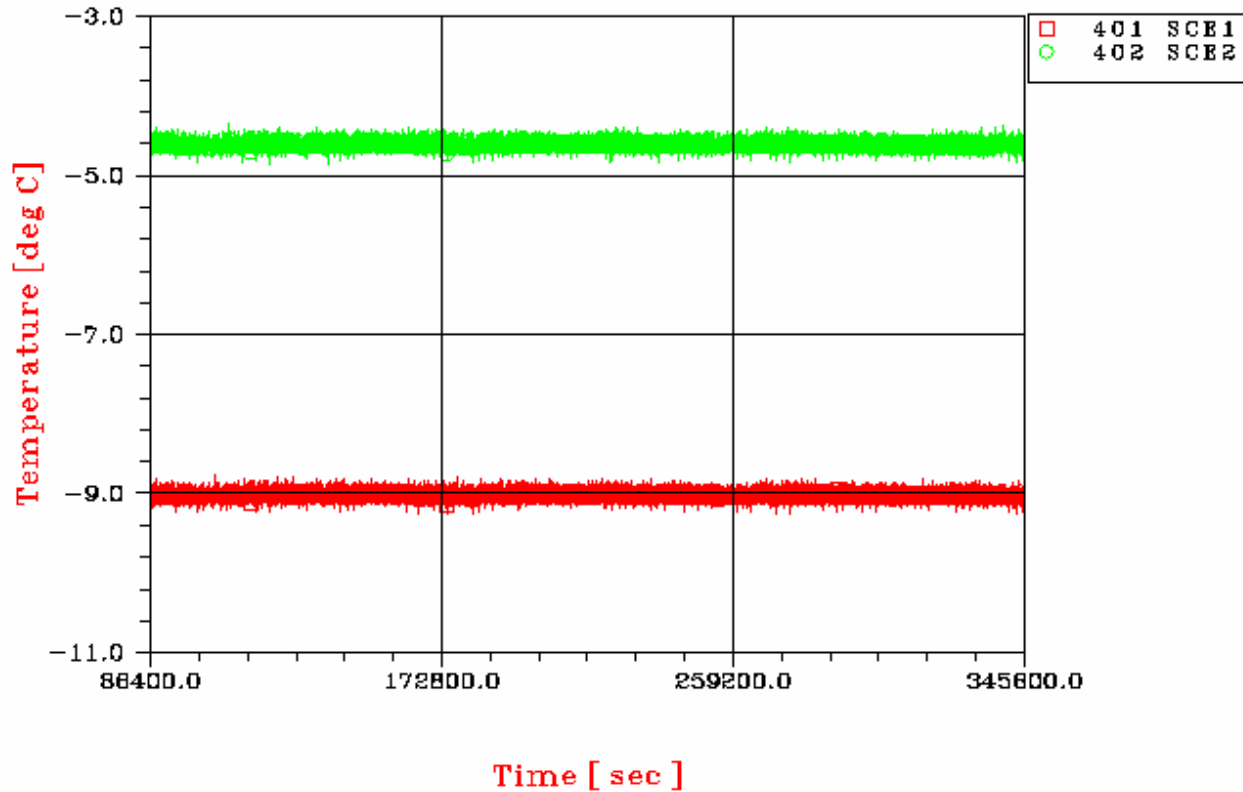

Controlled Distribution

REFERENCE : H-P-RP-AI-0040

DATE : 29/SEP/06

ISSUE : 06

Page : 340/405

**PLANCK - CASE B2 EOL SCC2 ON
SUBPLATFORM +X-X**

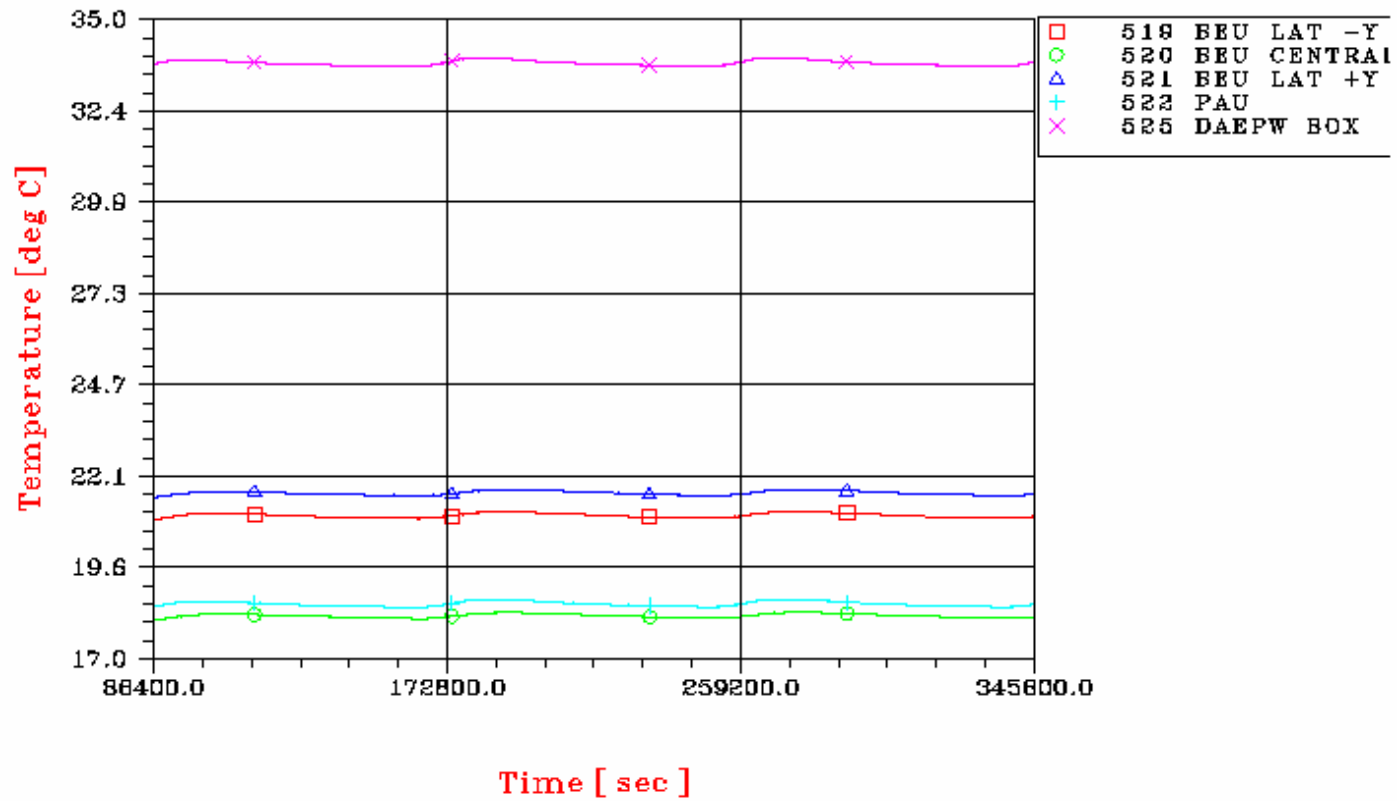

Controlled Distribution

REFERENCE : H-P-RP-AI-0040

DATE : 29/SEP/06

ISSUE : 06

Page : 341/405

PLANCK - CASE B2 EOL SCC2 ON
LATERAL PANEL - Y

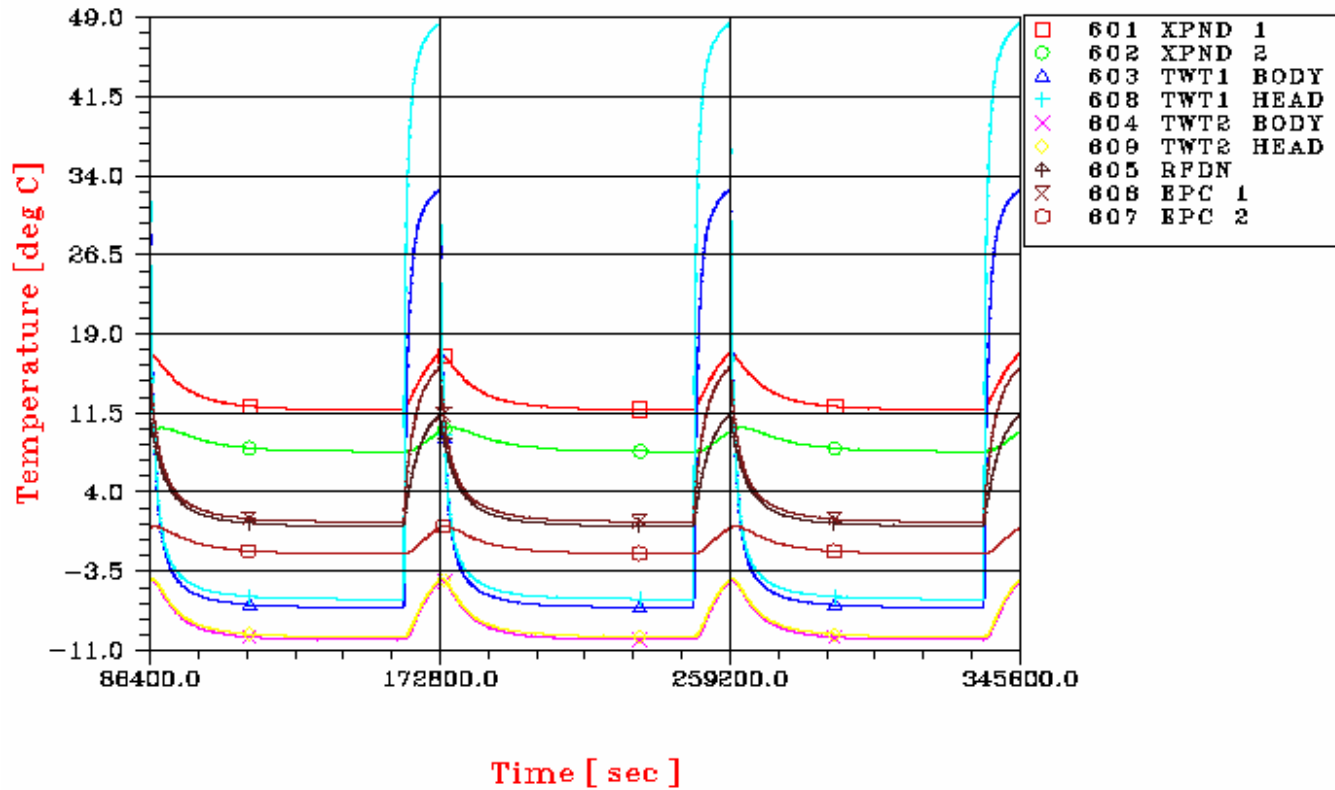

Controlled Distribution

REFERENCE : H-P-RP-AI-0040

DATE : 29/SEP/06

ISSUE : 06

Page : 342/405

**PLANCK - CASE B2 EOL SCC2 ON
LATERAL PANEL +Z-Y**

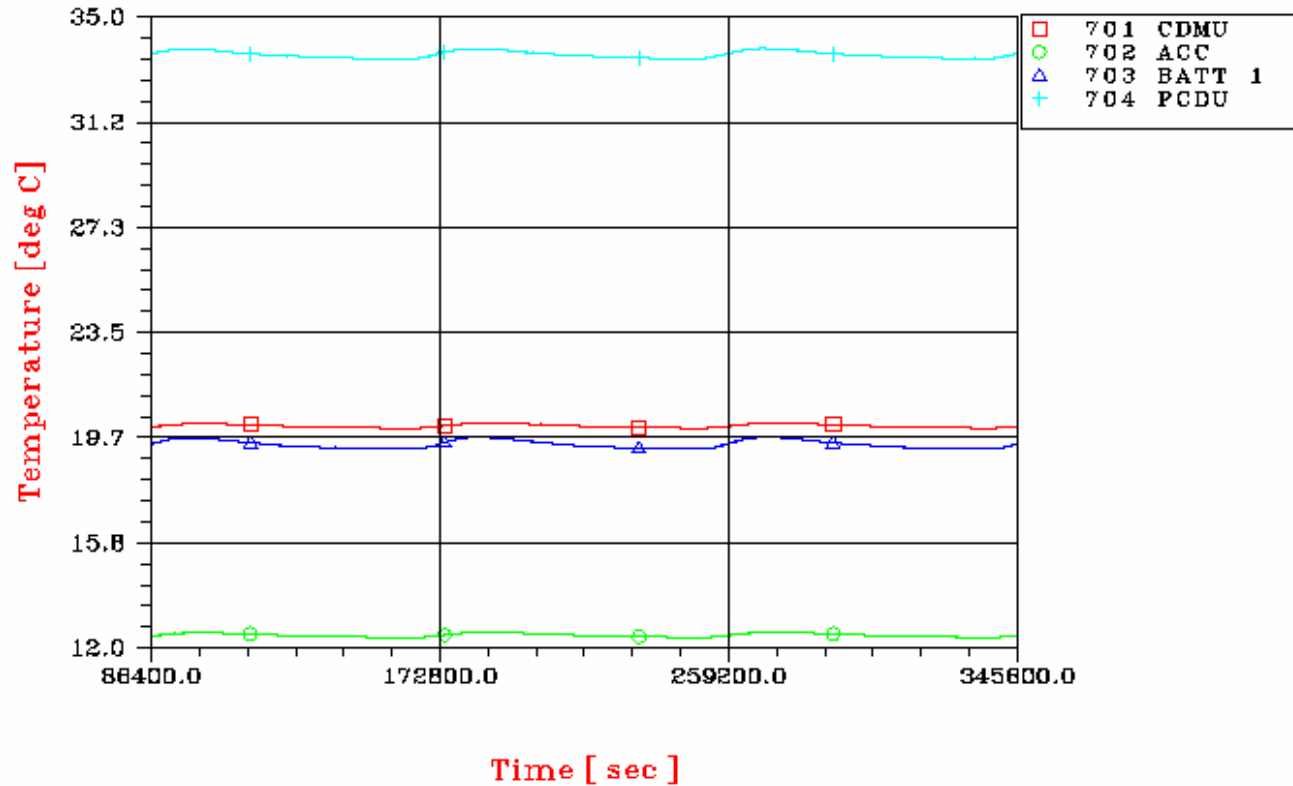

Controlled Distribution

REFERENCE : H-P-RP-AI-0040

DATE : 29/SEP/06

ISSUE : 06

Page : 343/405

PLANCK – CASE B2 EOL SCC2 ON
SHEAR PANEL – CRS

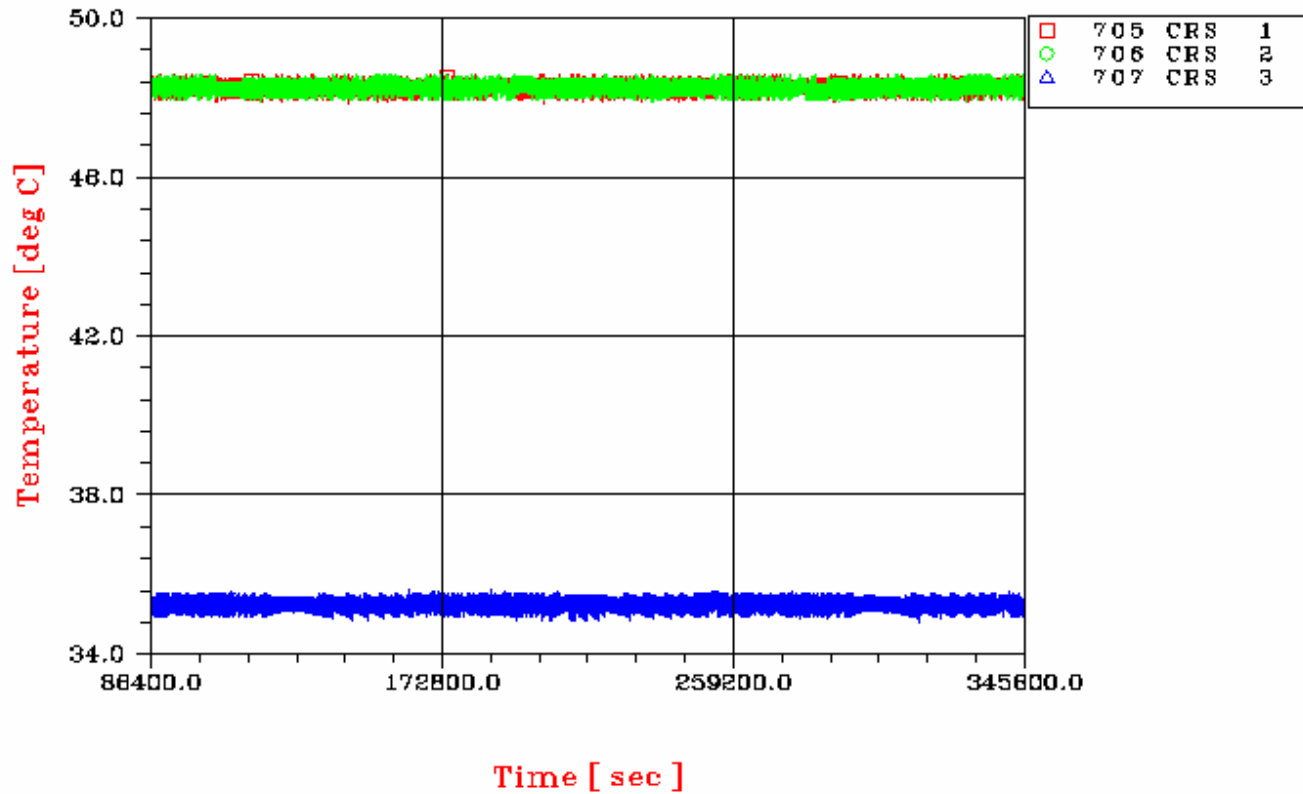

Controlled Distribution

REFERENCE : H-P-RP-AI-0040

DATE : 29/SEP/06

ISSUE : 06

Page : 344/405

PLANCK - CASE B2 EOL SCC2 ON
SHEAR PANEL - CRS detail

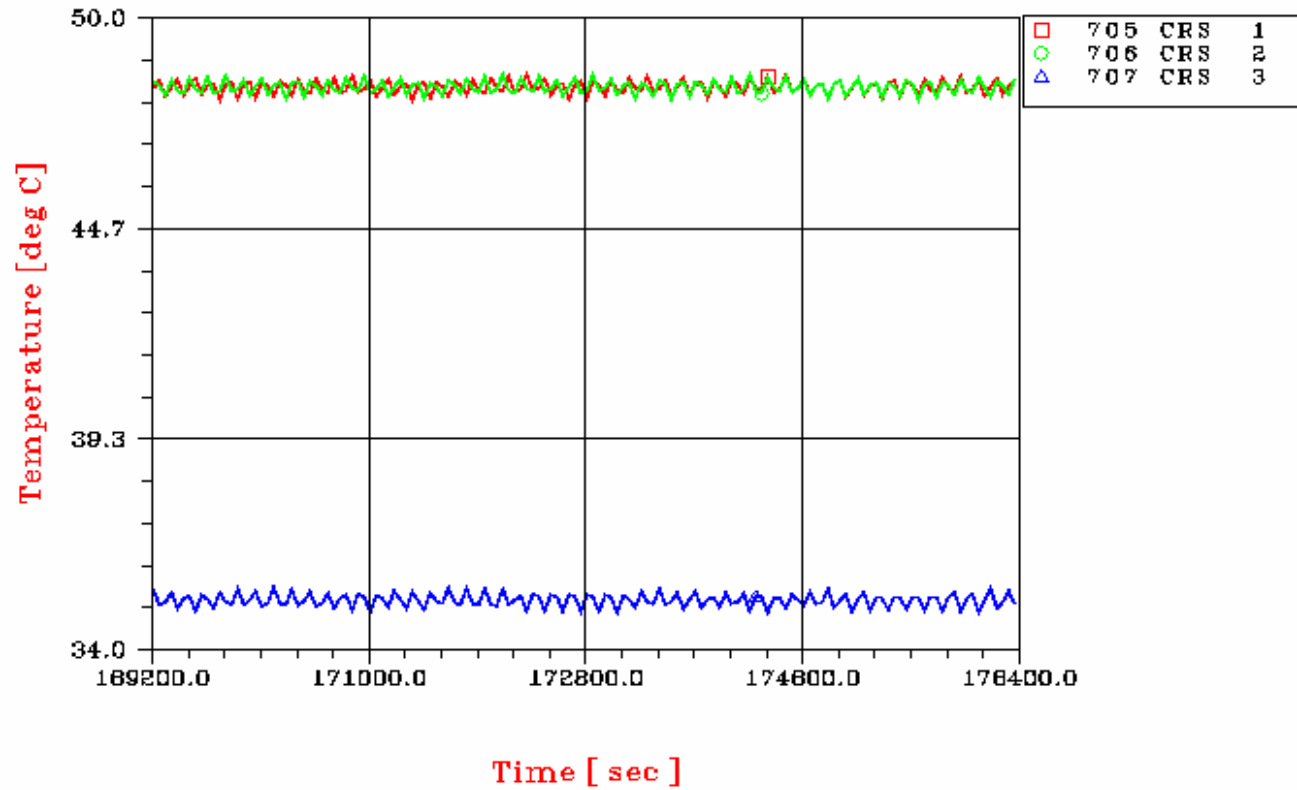

Controlled Distribution

REFERENCE : H-P-RP-AI-0040

DATE : 29/SEP/06

ISSUE : 06

Page : 345/405

**PLANCK – CASE B2 EOL SCC2 ON
PROPELLANT TANK**

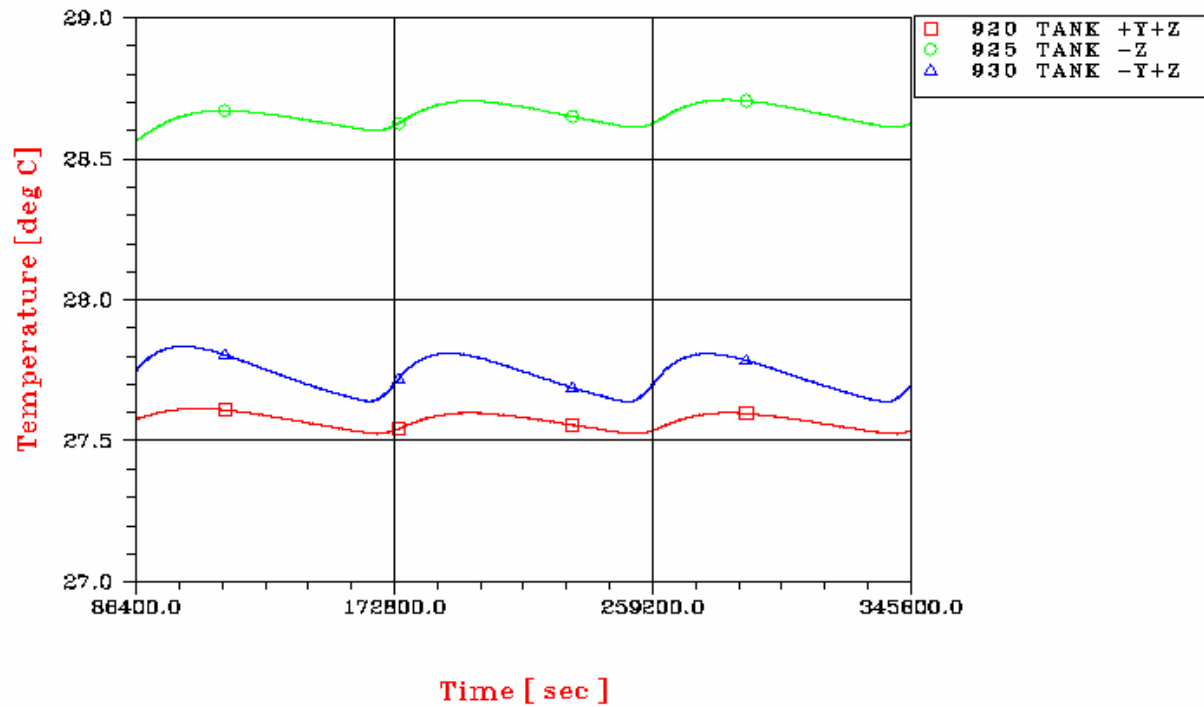

Controlled Distribution

REFERENCE : H-P-RP-AI-0040

DATE : 29/SEP/06

ISSUE : 06

Page : 346/405

**PLANCK – CASE B2 EOL SCC2 ON
HE TANK**

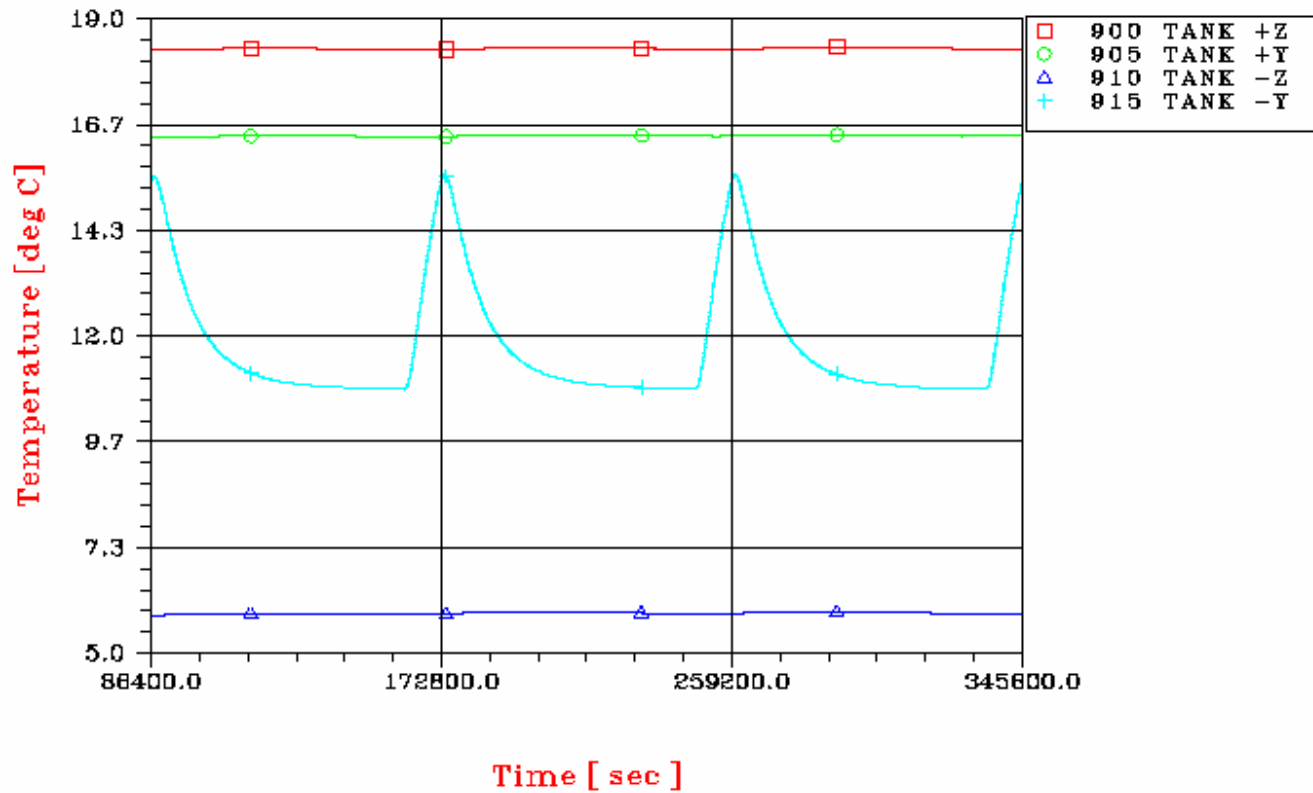

Controlled Distribution

REFERENCE : H-P-RP-AI-0040

DATE : 29/SEP/06

ISSUE : 06

Page : 347/405

**PLANCK – CASE B2 EOL SCC2 ON
SCC1 OFF**

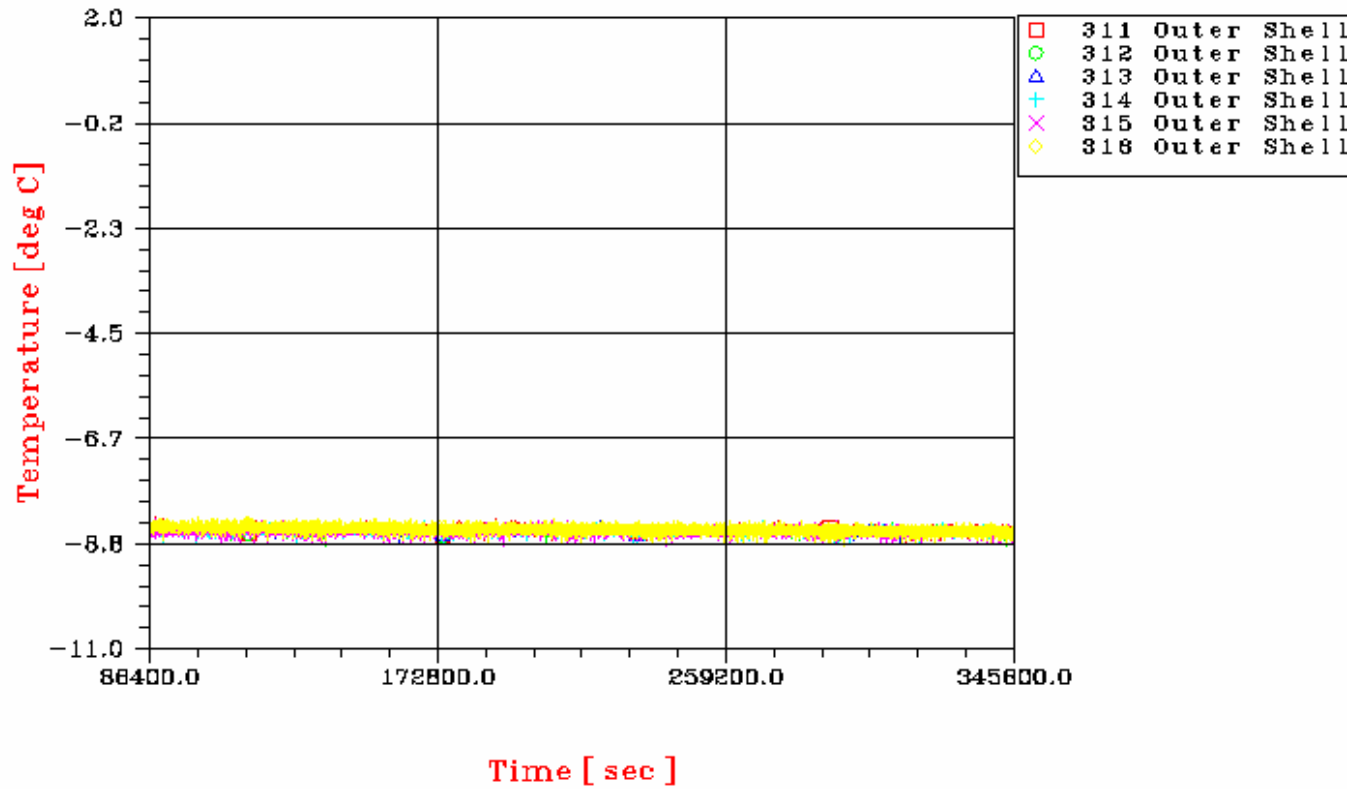

Controlled Distribution

REFERENCE : H-P-RP-AI-0040

DATE : 29/SEP/06

ISSUE : 06

Page : 348/405

**PLANCK – CASE B2 EOL SCC2 ON
SCC1**

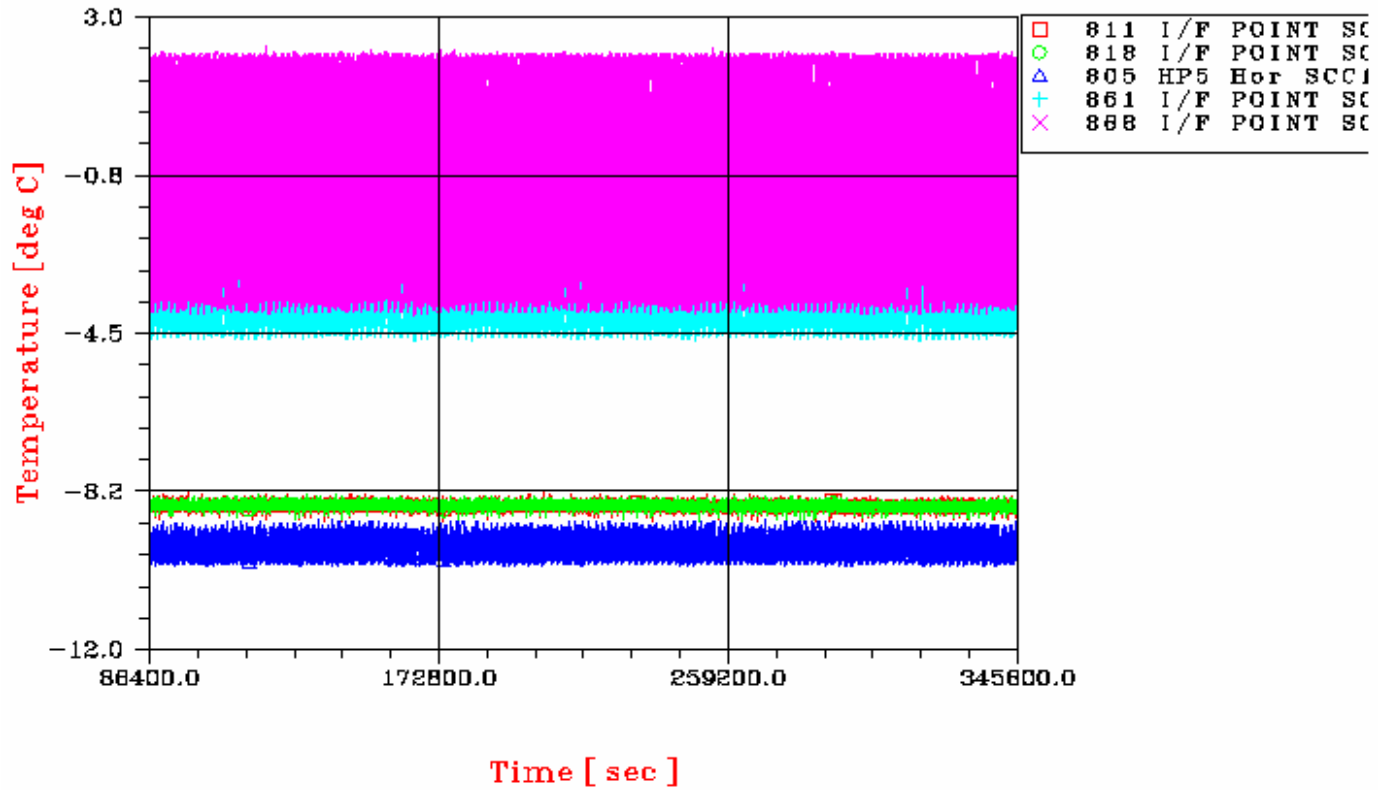

Controlled Distribution

REFERENCE : H-P-RP-AI-0040

DATE : 29/SEP/06

ISSUE : 06

Page : 349/405

**PLANCK – CASE B2 EOL SCC2 ON
SCC1**

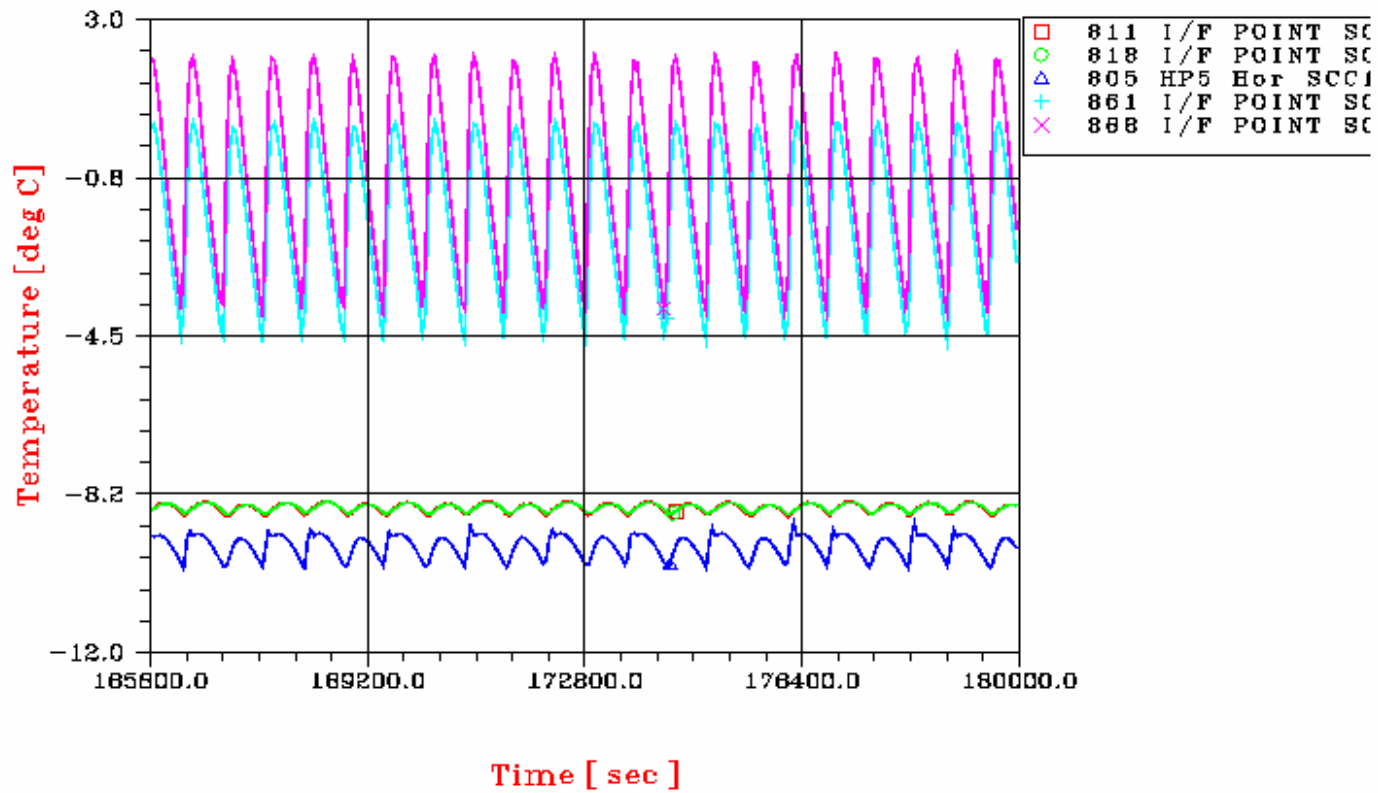

Controlled Distribution

REFERENCE : H-P-RP-AI-0040

DATE : 29/SEP/06

ISSUE : 06

Page : 350/405

PLANCK – CASE B2 EOL SCC2 ON
SCC2 ON

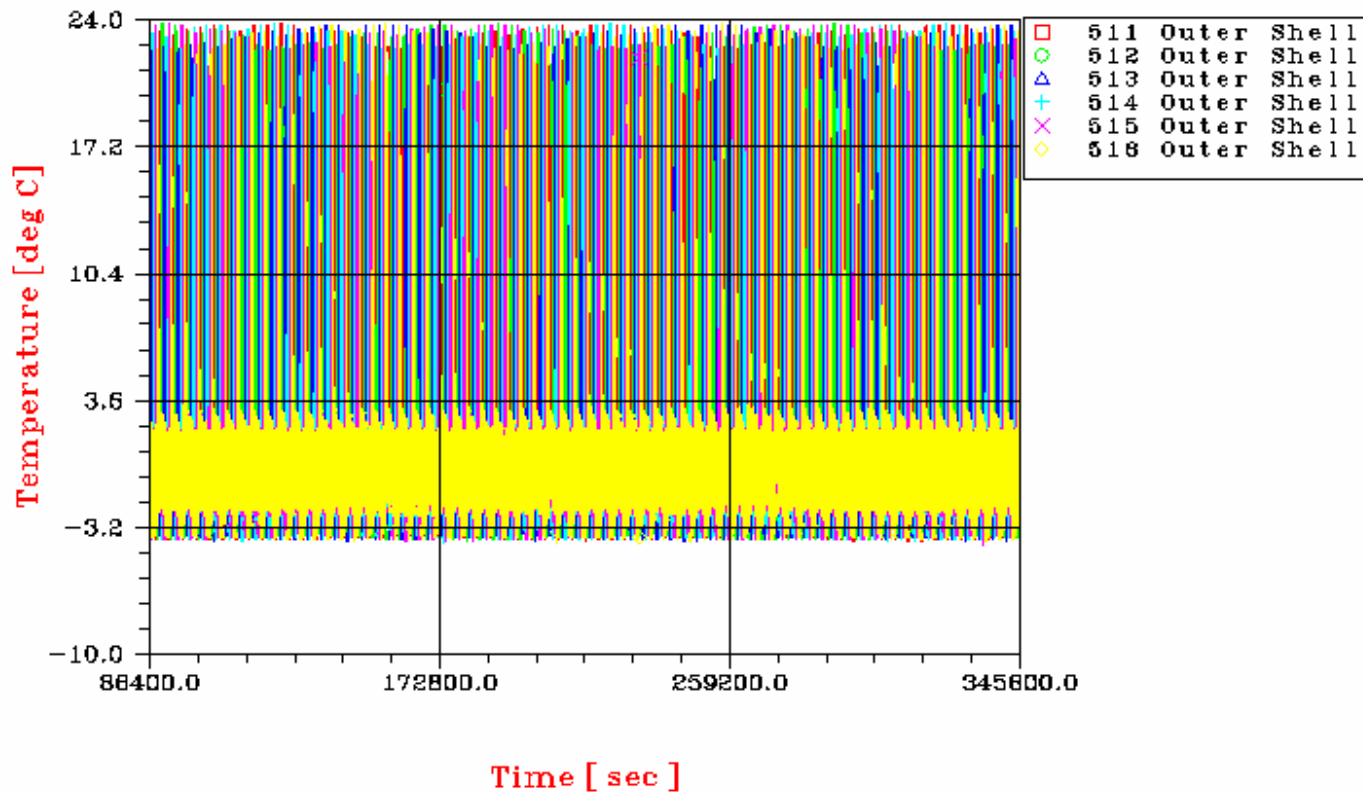

Controlled Distribution

REFERENCE : H-P-RP-AI-0040

DATE : 29/SEP/06

ISSUE : 06

Page : 351/405

PLANCK – CASE B2 EOL SCC2 ON
SCC2 ON

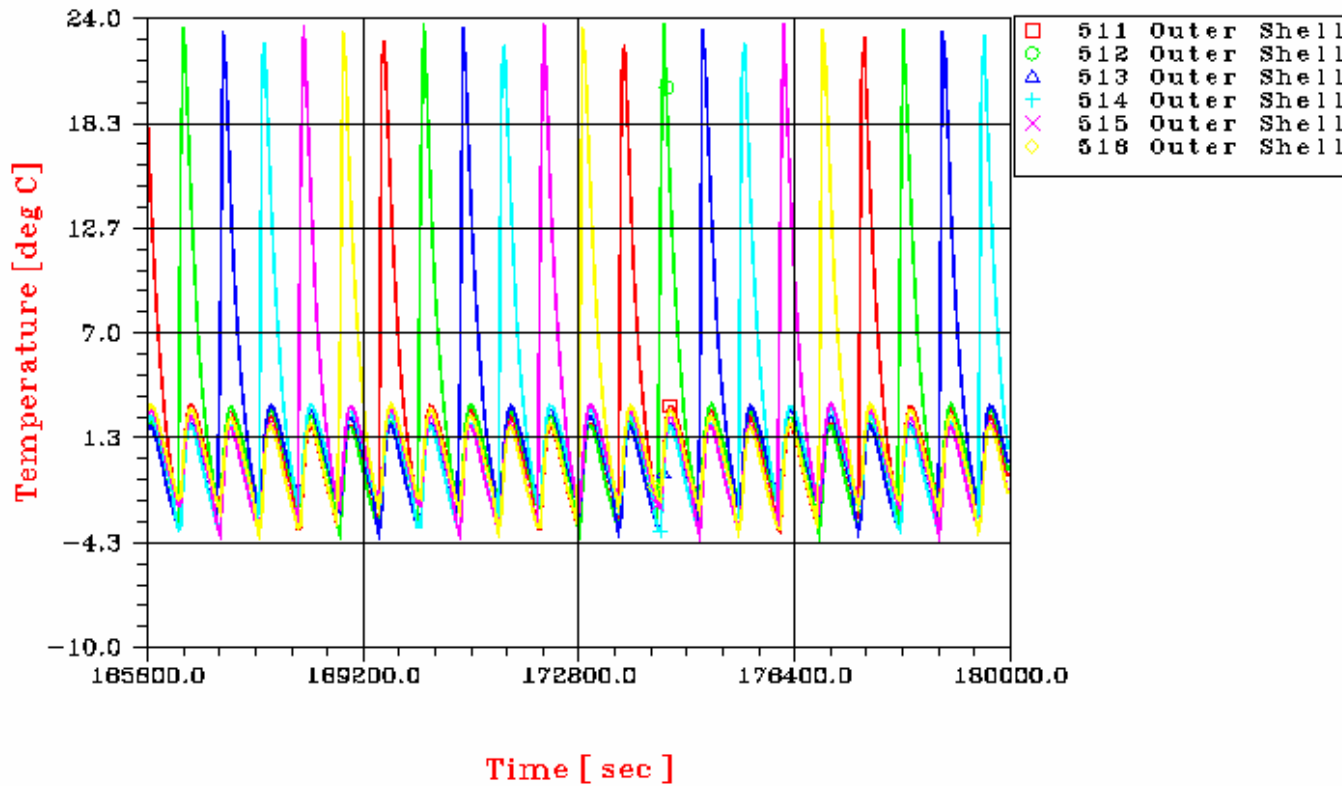

Controlled Distribution

REFERENCE : H-P-RP-AI-0040

DATE : 29/SEP/06

ISSUE : 06

Page : 352/405

PLANCK CASE B2 EOL SCC2 ON

RCS line #32

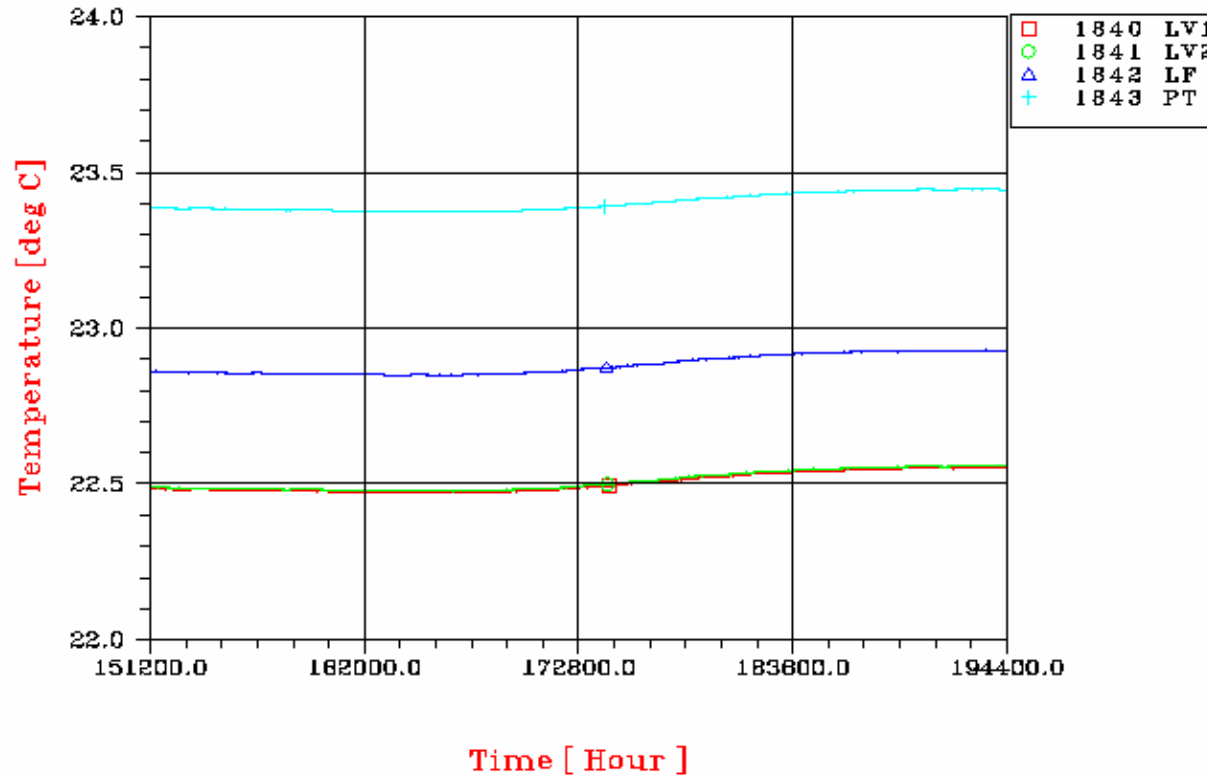

Controlled Distribution

REFERENCE : H-P-RP-AI-0040

DATE : 29/SEP/06

ISSUE : 06

Page : 353/405

PLANCK CASE B2 EOL SCC2 ON

RCS line #33

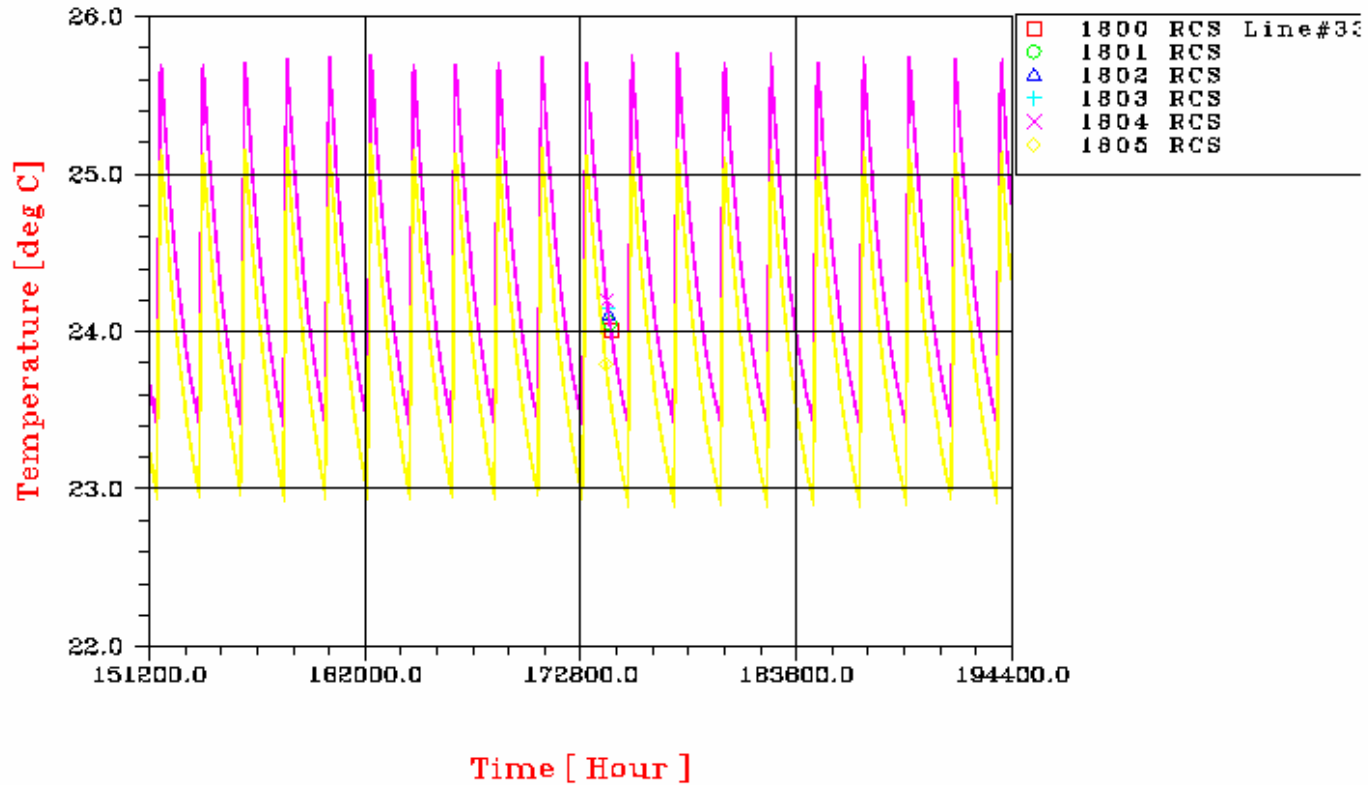

Controlled Distribution

REFERENCE : H-P-RP-AI-0040

DATE : 29/SEP/06

ISSUE : 06

Page : 354/405

PLANCK CASE B2 EOL SCC2 ON

RCS line #33

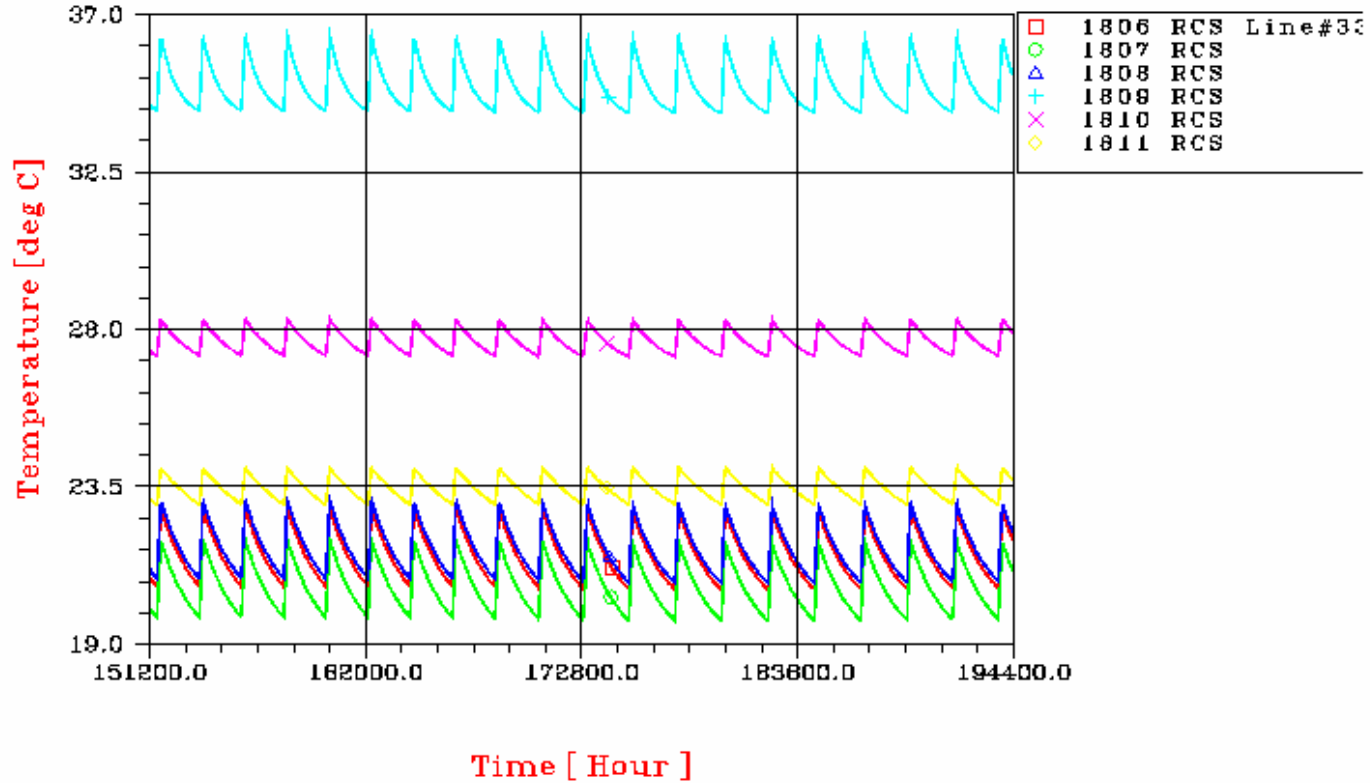

Controlled Distribution

REFERENCE : H-P-RP-AI-0040

DATE : 29/SEP/06

ISSUE : 06

Page : 355/405

PLANCK CASE B2 EOL SCC2 ON

RCS line #33

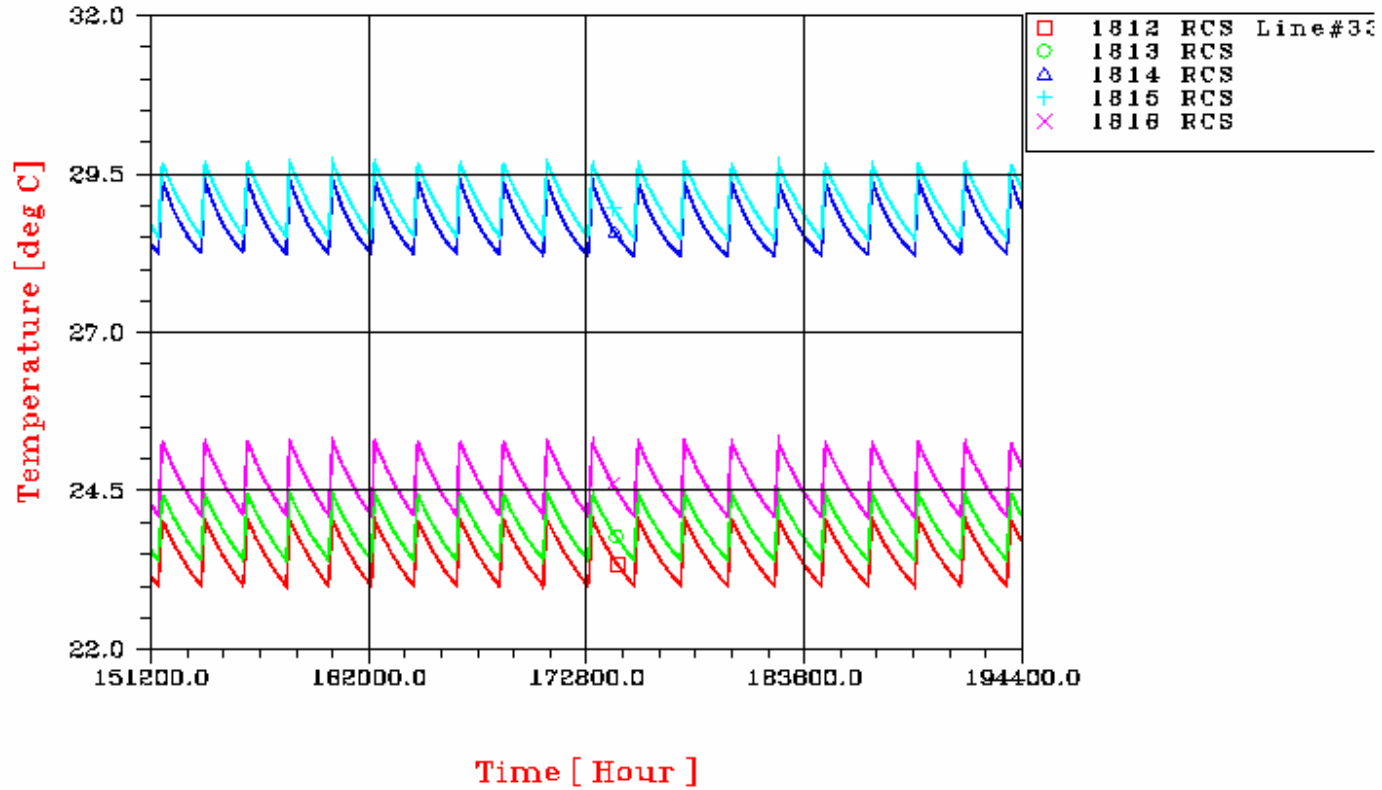

Controlled Distribution

REFERENCE : H-P-RP-AI-0040

DATE : 29/SEP/06

ISSUE : 06

Page : 356/405

PLANCK CASE B2 EOL SCC2 ON

RCS line #34

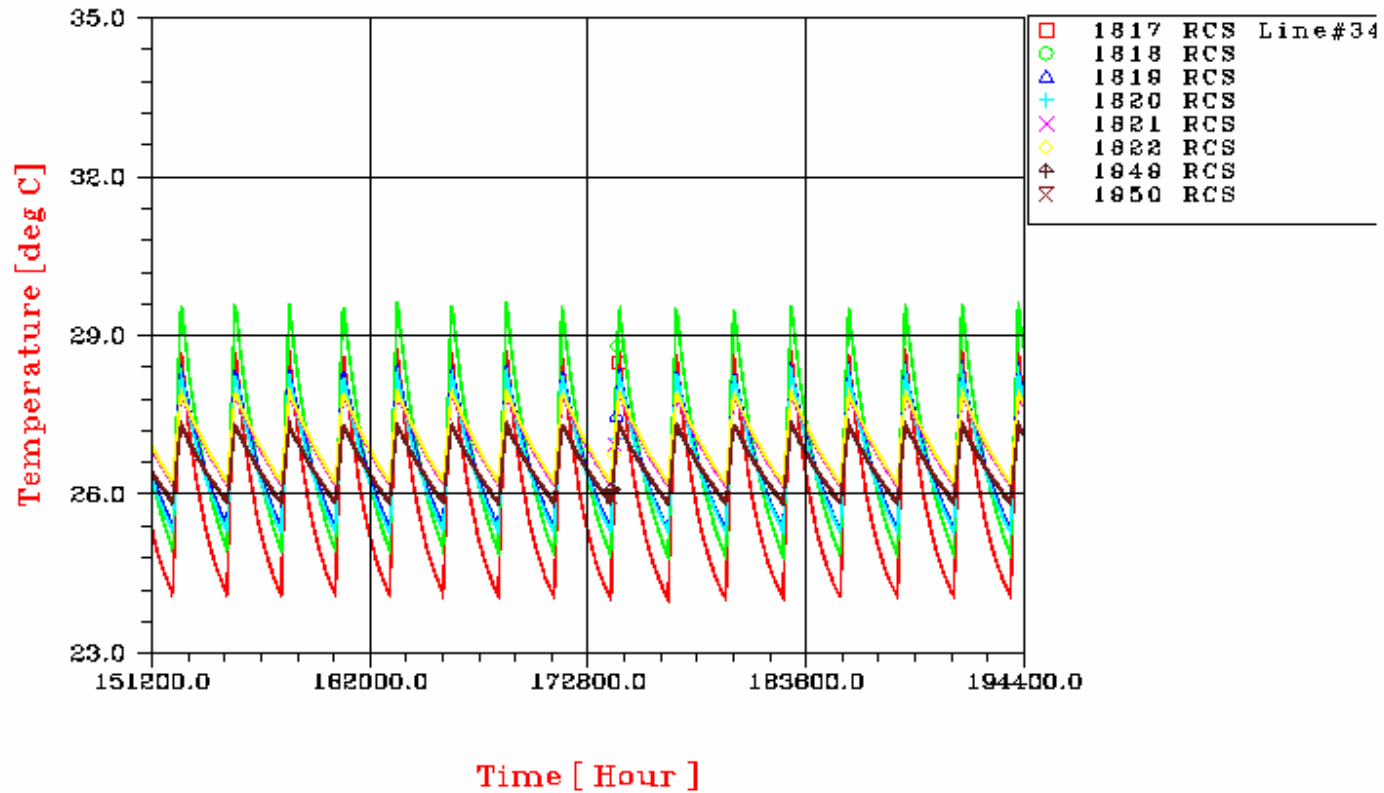

Controlled Distribution

REFERENCE : H-P-RP-AI-0040

DATE : 29/SEP/06

ISSUE : 06

Page : 357/405

PLANCK CASE B2 EOL SCC2 ON
RCS line #34

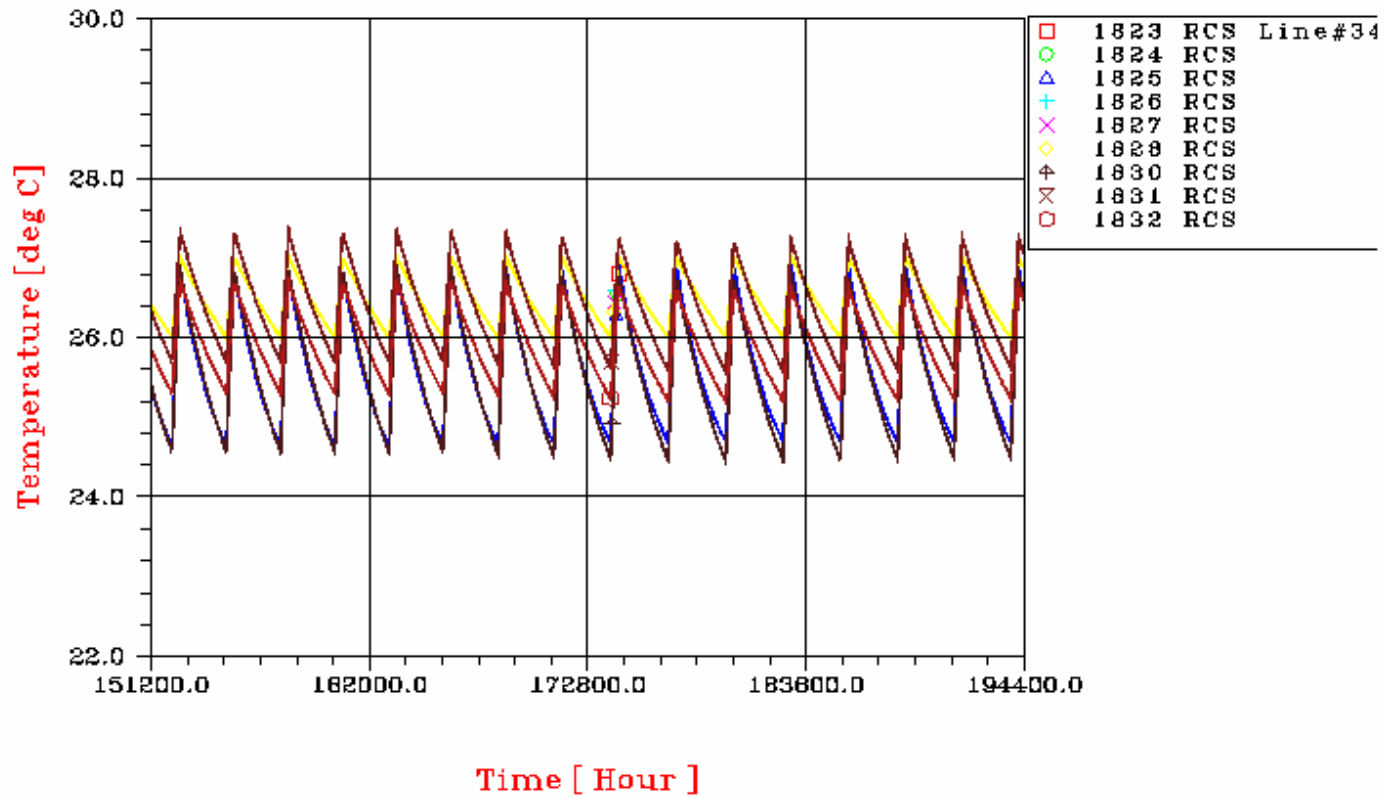

Controlled Distribution

REFERENCE : H-P-RP-AI-0040

DATE : 29/SEP/06

ISSUE : 06

Page : 358/405

PLANCK CASE B2 EOL SCC2 ON

RCS line #34

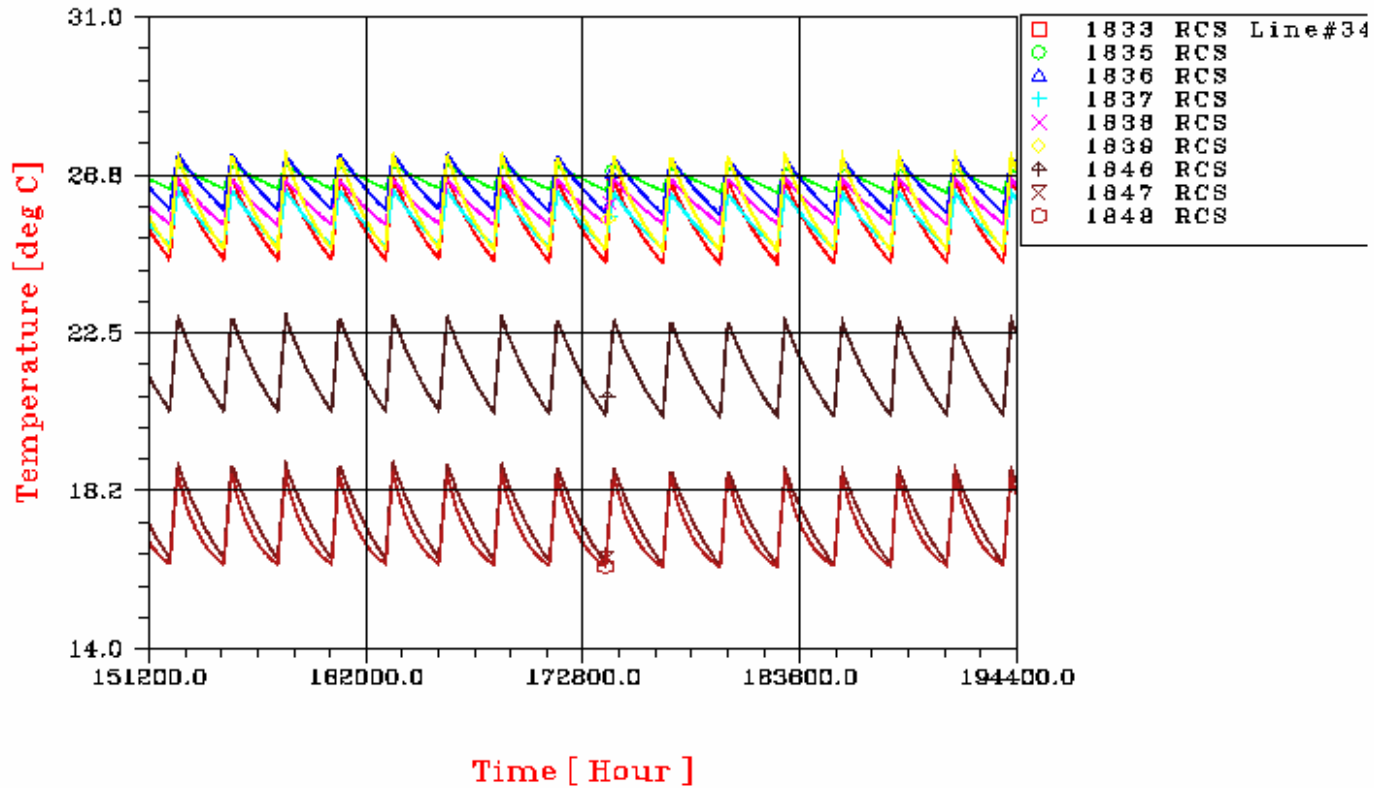

Controlled Distribution

REFERENCE : H-P-RP-AI-0040

DATE : 29/SEP/06

ISSUE : 06

Page : 359/405

PLANCK CASE B2 EOL SCC2 ON
RCS line #46

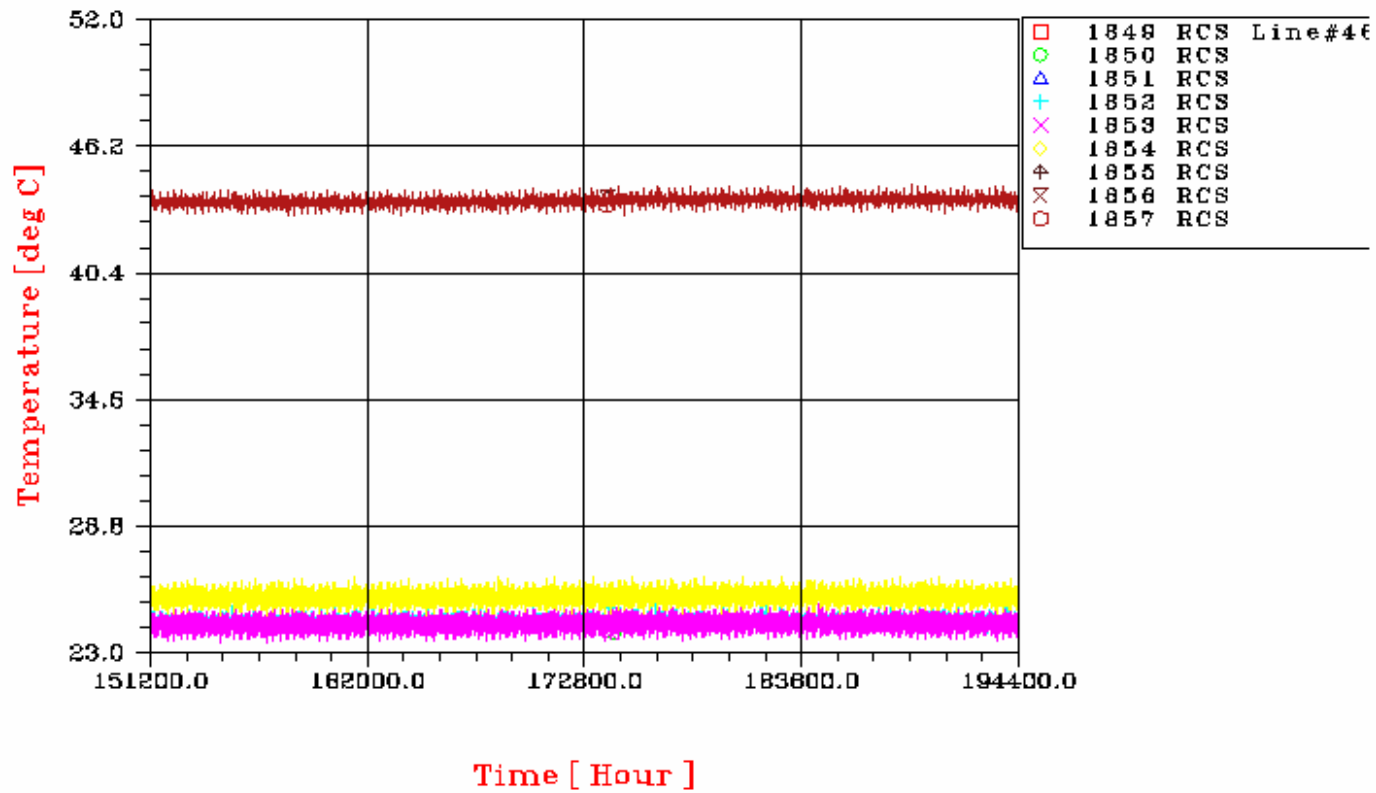

Controlled Distribution

REFERENCE : H-P-RP-AI-0040

DATE : 29/SEP/06

ISSUE : 06

Page : 360/405

PLANCK CASE B2 EOL SCC2 ON
RCS line #46

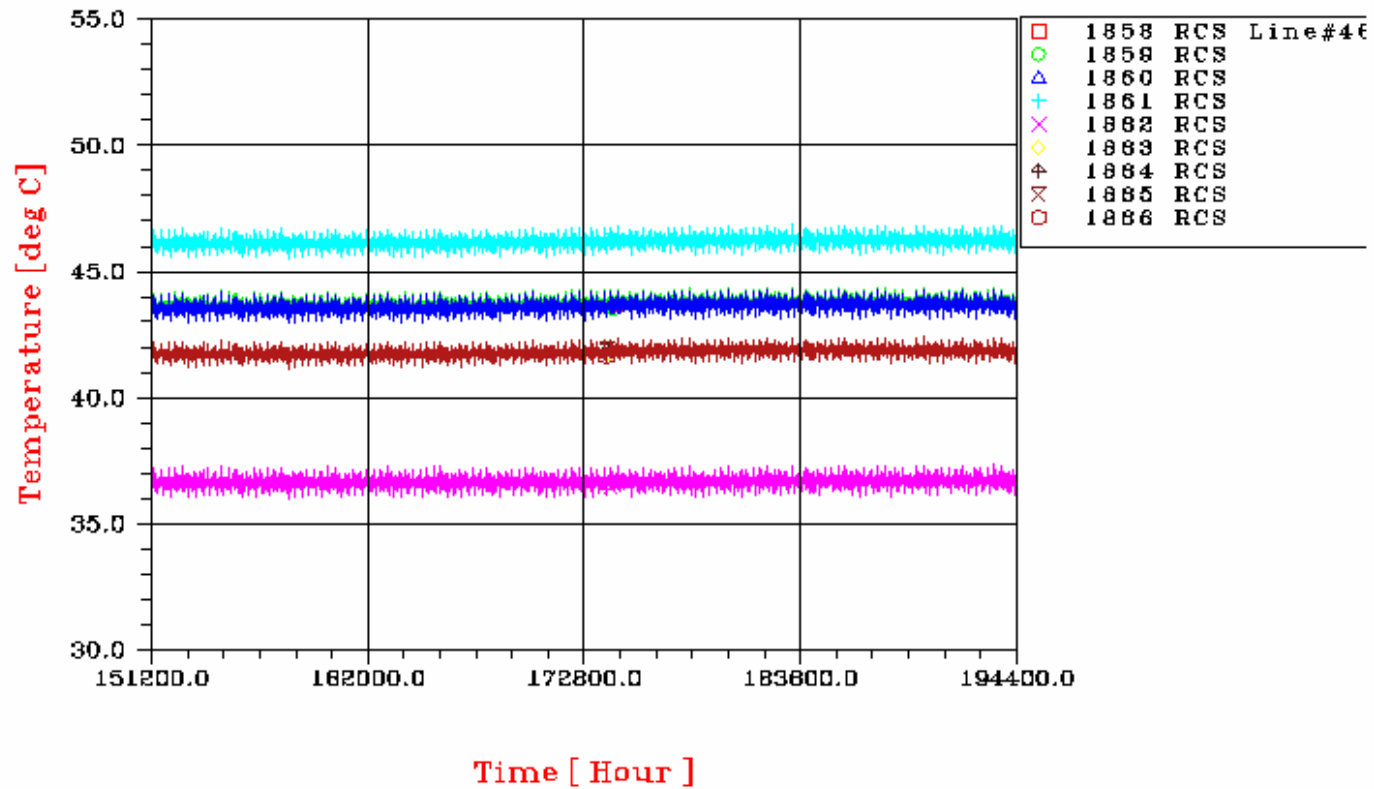

Controlled Distribution

REFERENCE : H-P-RP-AI-0040

DATE : 29/SEP/06

ISSUE : 06

Page : 361/405

PLANCK CASE B2 EOL SCC2 ON

RCS line #46

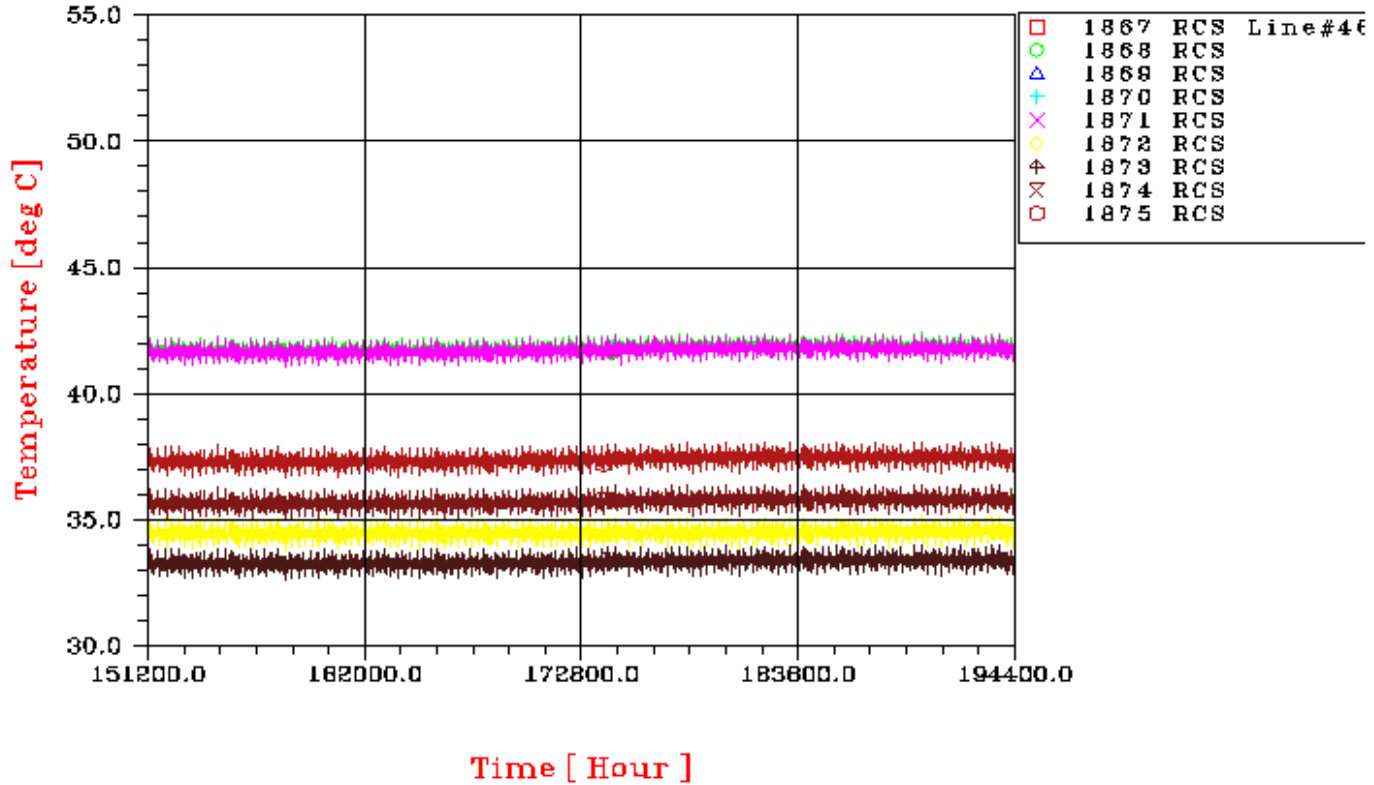

Controlled Distribution

REFERENCE : H-P-RP-AI-0040

DATE : 29/SEP/06

ISSUE : 06

Page : 362/405

PLANCK CASE B2 EOL SCC2 ON

RCS line #46

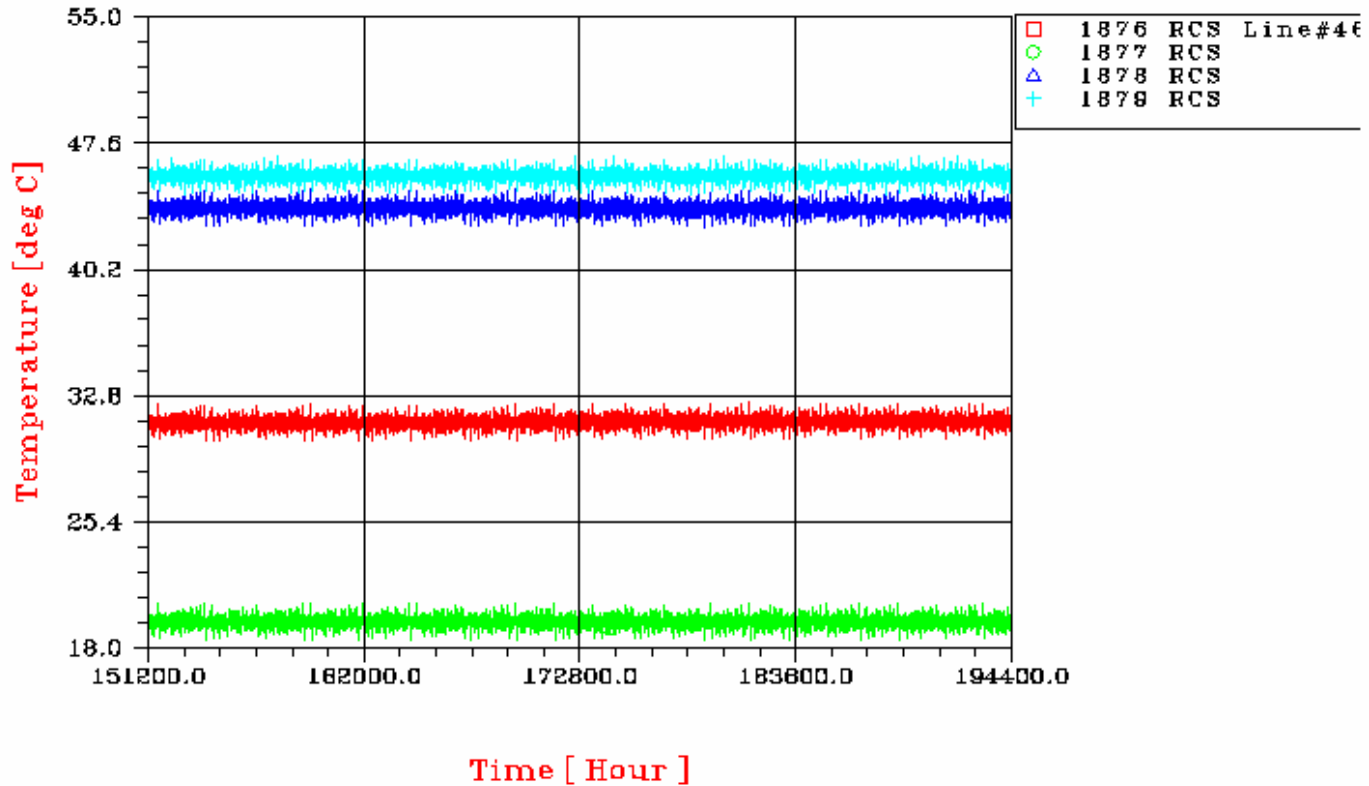

Controlled Distribution

REFERENCE : H-P-RP-AI-0040

DATE : 29/SEP/06

ISSUE : 06

Page : 363/405

PLANCK CASE B2 EOL SCC2 ON

RCS line #47

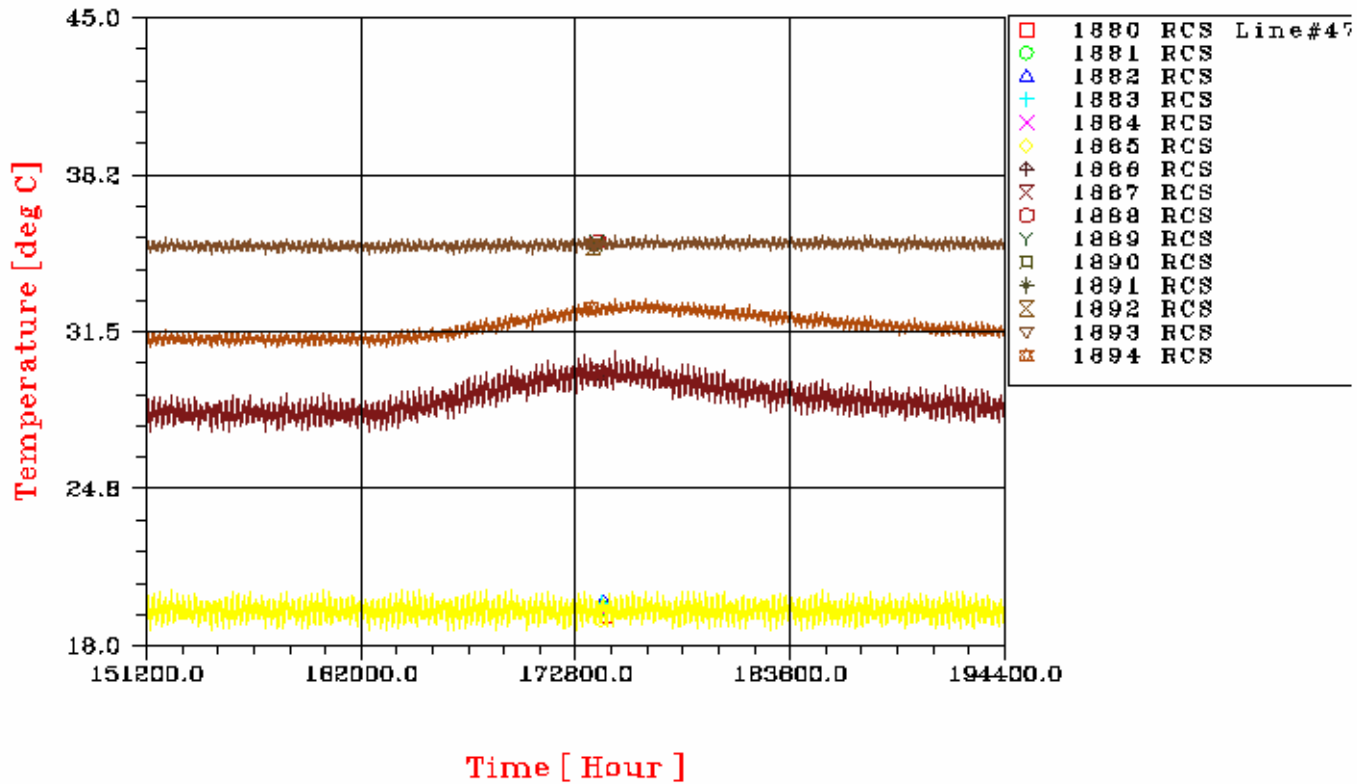

Controlled Distribution

REFERENCE : H-P-RP-AI-0040

DATE : 29/SEP/06

ISSUE : 06

Page : 364/405

PLANCK CASE B2 EOL SCC2 ON

RCS line #47

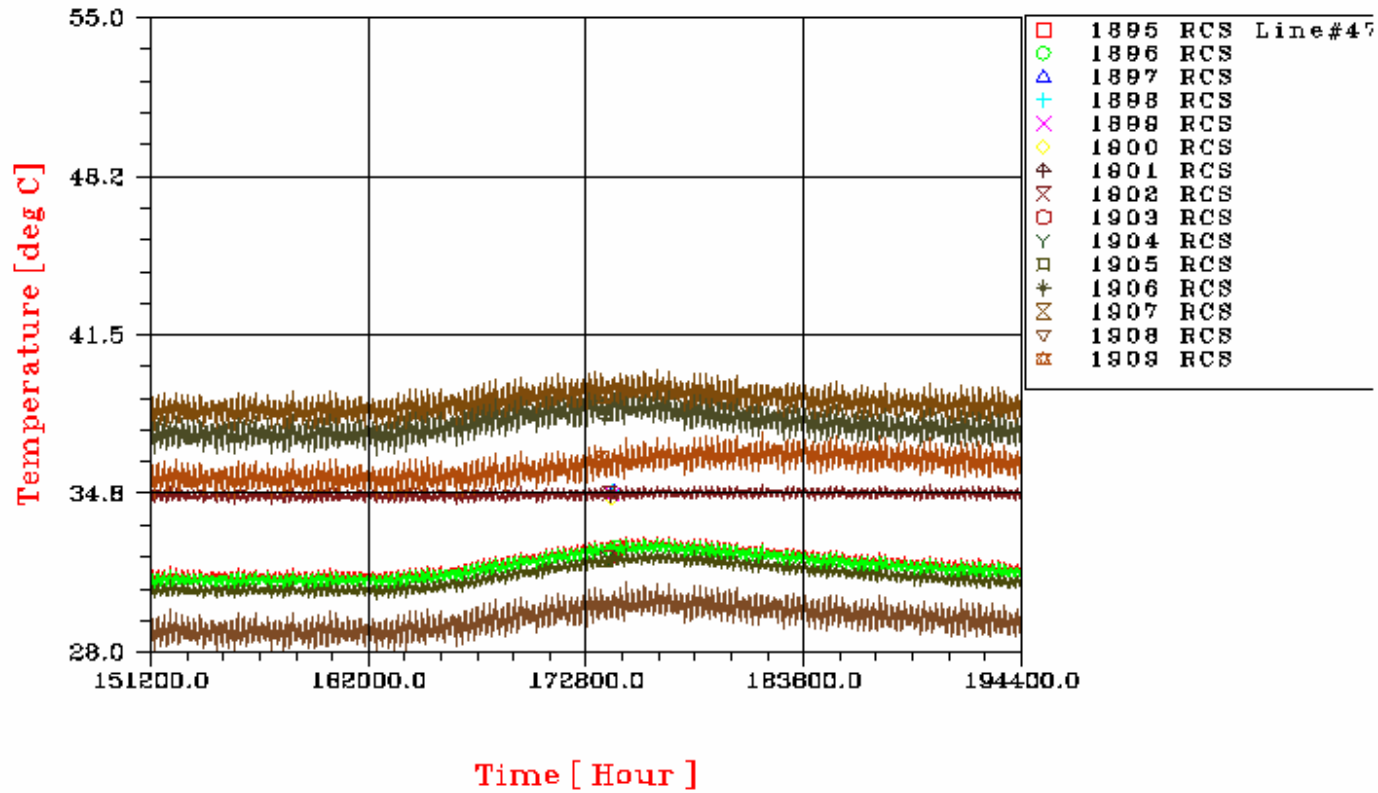

Controlled Distribution

REFERENCE : H-P-RP-AI-0040

DATE : 29/SEP/06

ISSUE : 06

Page : 365/405

PLANCK CASE B2 EOL SCC2 ON
RCS line #47

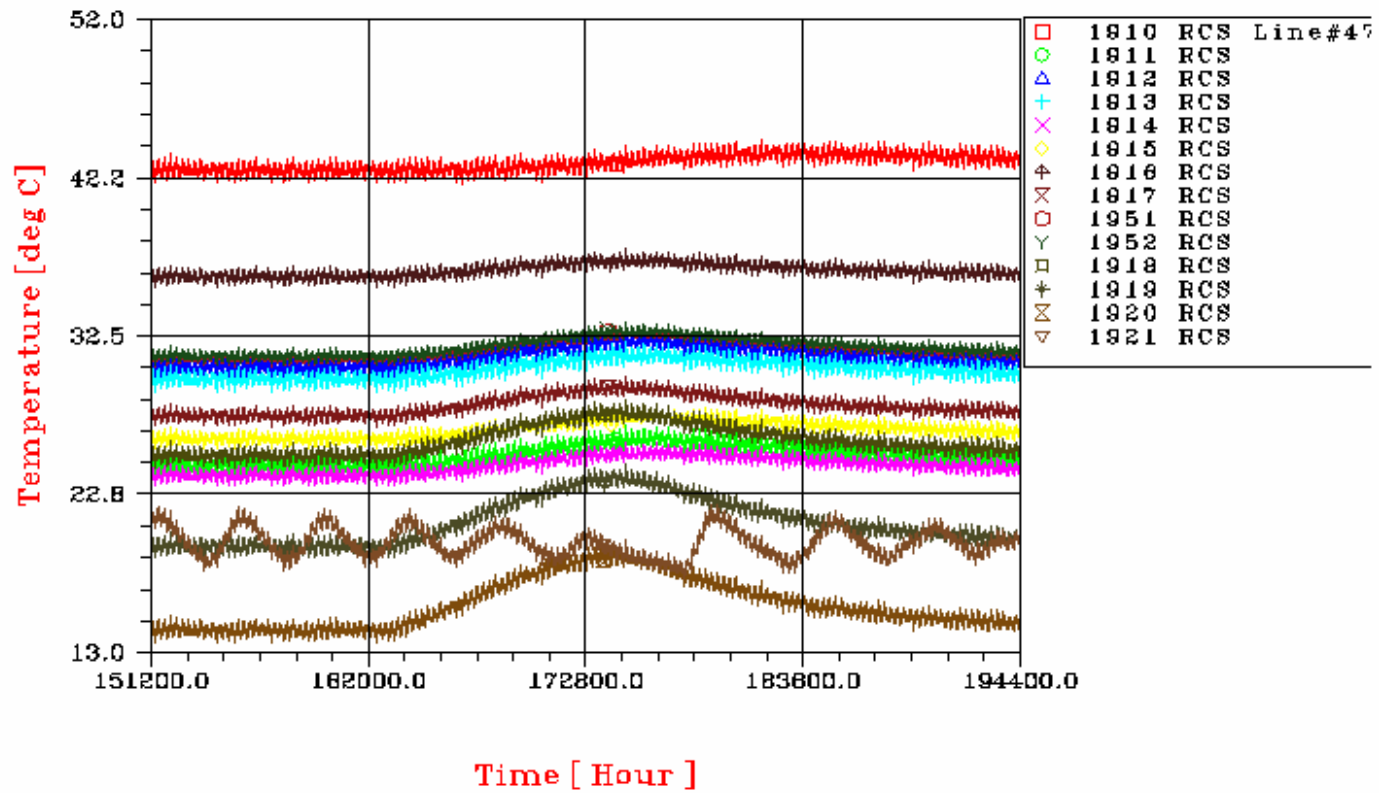

Controlled Distribution

REFERENCE : H-P-RP-AI-0040

DATE : 29/SEP/06

ISSUE : 06

Page : 366/405

PLANCK CASE B2 EOL SCC2 ON

RCS line #48

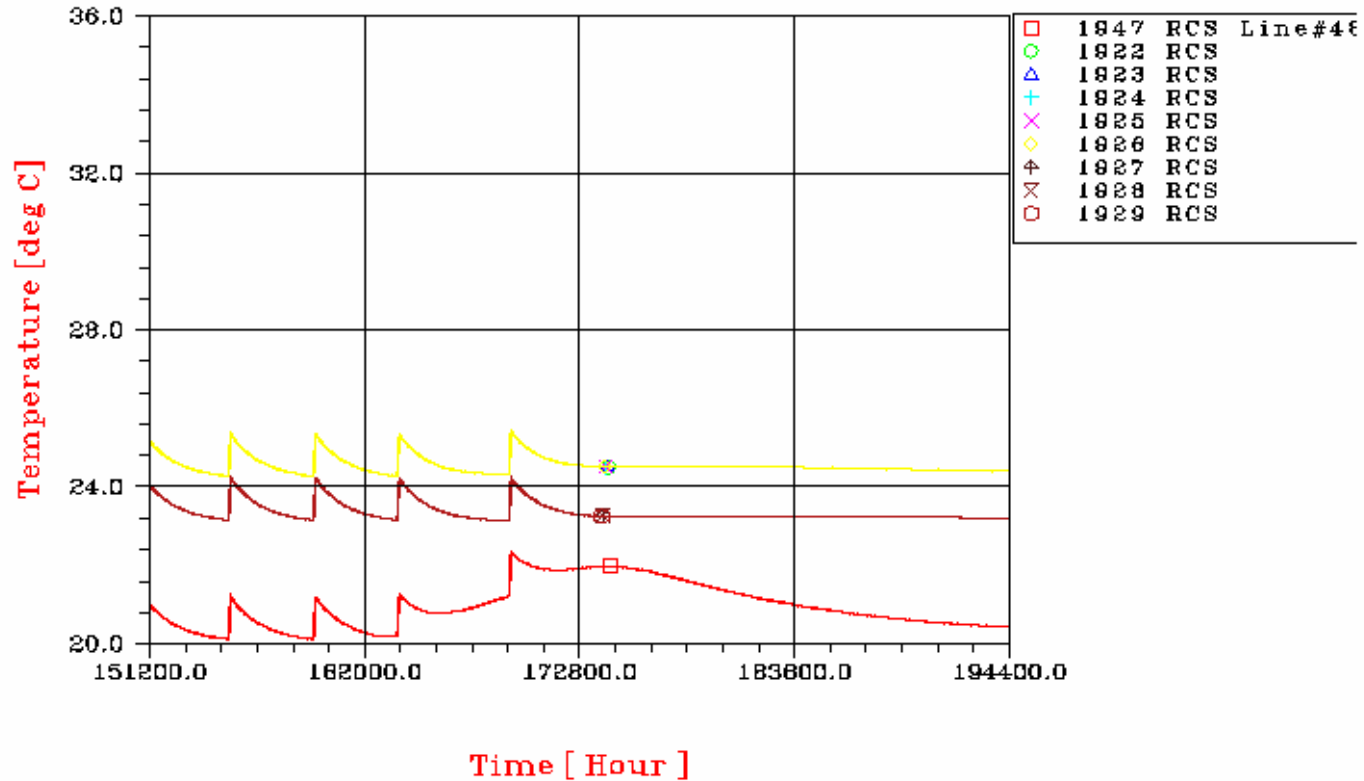

Controlled Distribution

REFERENCE : H-P-RP-AI-0040

DATE : 29/SEP/06

ISSUE : 06

Page : 367/405

PLANCK CASE B2 EOL SCC2 ON

RCS line #48

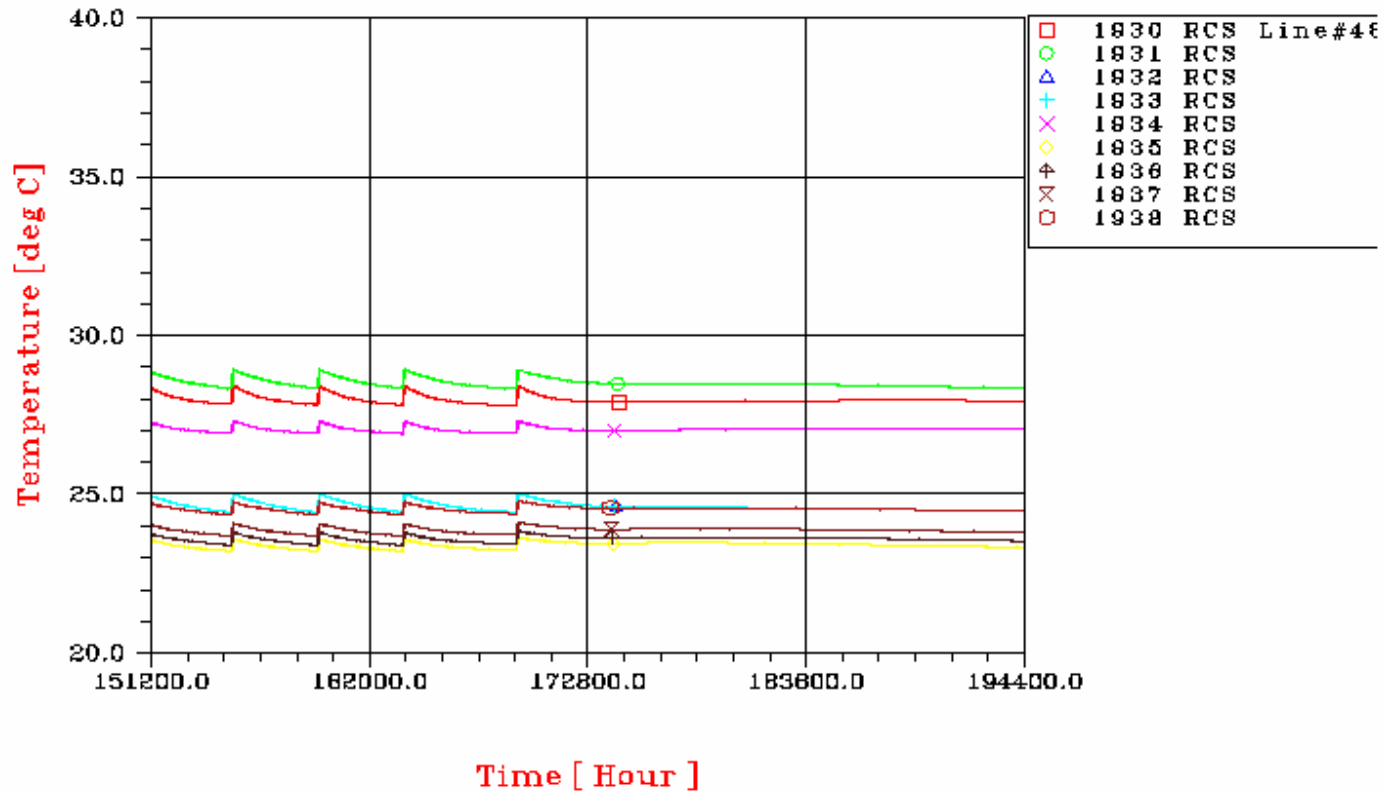

Controlled Distribution

REFERENCE : H-P-RP-AI-0040

DATE : 29/SEP/06

ISSUE : 06

Page : 368/405

PLANCK CASE B2 EOL SCC2 ON

RCS line #48

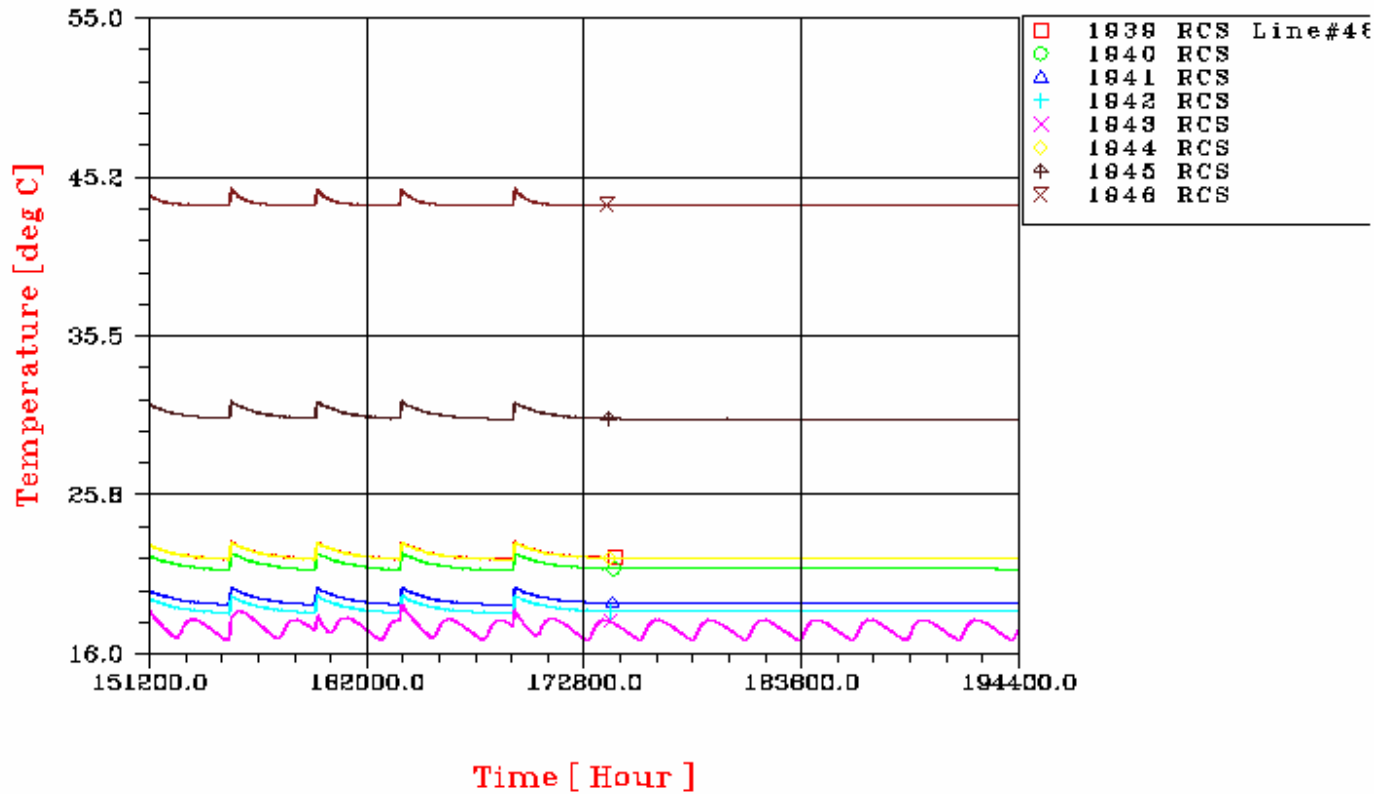

Controlled Distribution

REFERENCE : H-P-RP-AI-0040

DATE : 29/SEP/06

ISSUE : 06

Page : 369/405

11.3 PLANCK: PLOTS OF TRANSIENT NOMINAL ANALYSIS CASE C

In the following figures, the temperature plots of the transient nominal analysis concerning the satellite in BOL condition and Survival mode are presented.

Controlled Distribution

REFERENCE : H-P-RP-AI-0040

DATE : 29/SEP/06

ISSUE : 06

Page : 370/405

Intentionally left blank

Controlled Distribution

REFERENCE : H-P-RP-AI-0040

DATE : 29/SEP/06

ISSUE : 06

Page : 371/405

PLANCK - CASE C BOL SURVIVAL
LATERAL PANEL +Z

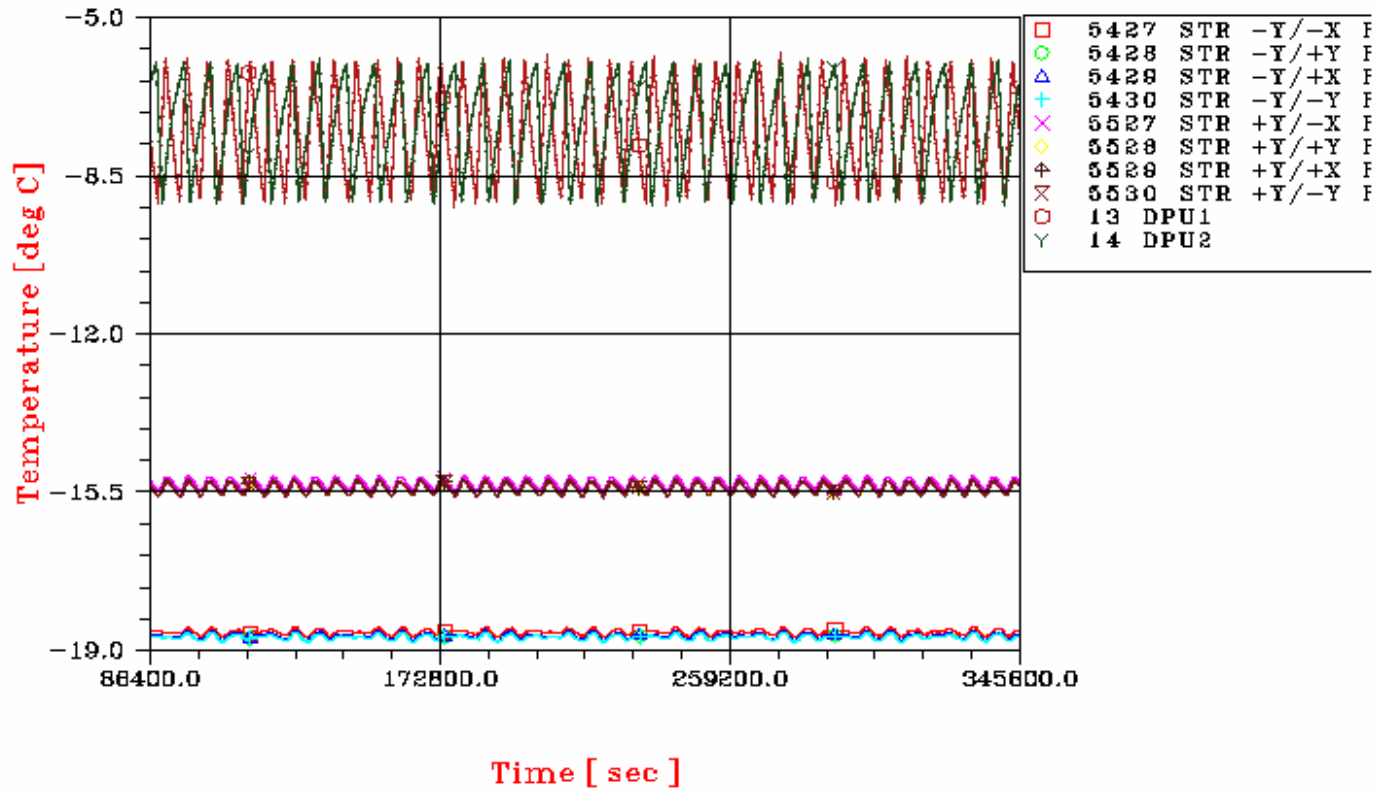

Controlled Distribution

REFERENCE : H-P-RP-AI-0040

DATE : 29/SEP/06

ISSUE : 06

Page : 372/405

**PLANCK – CASE C BOL SURVIVAL
LATERAL PANEL +Z+Y**

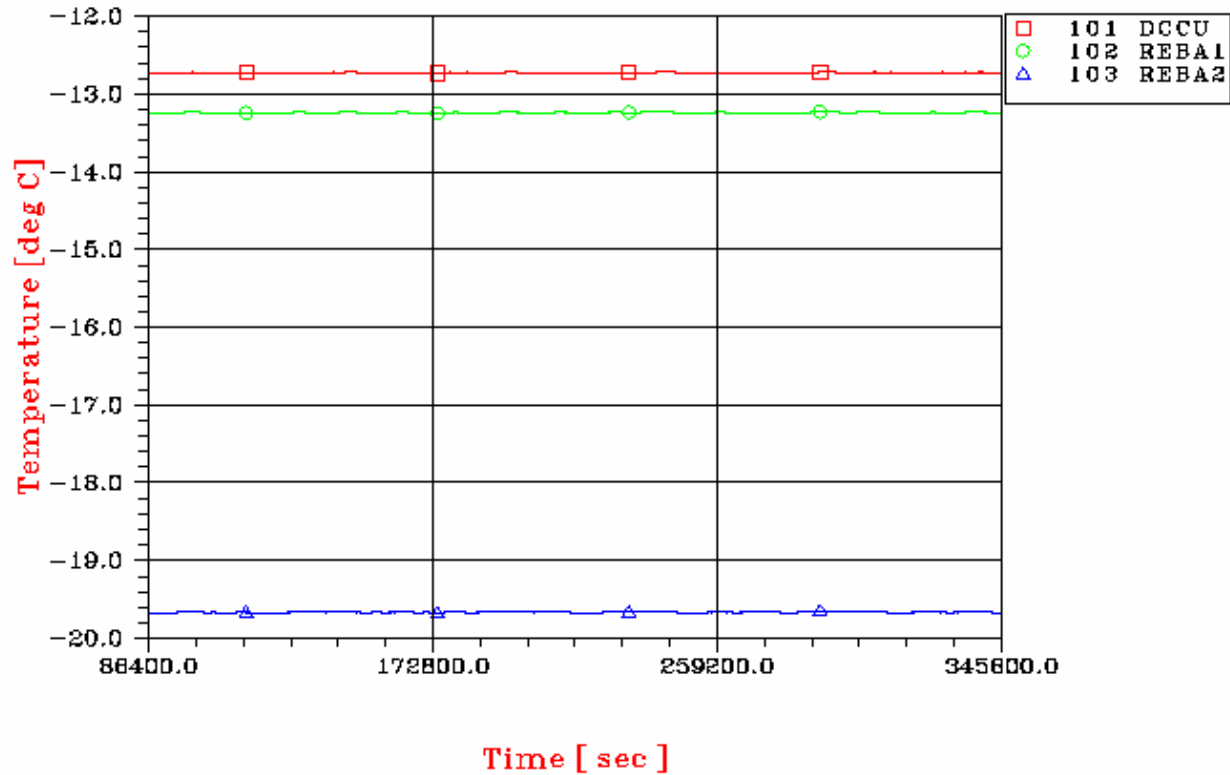

Controlled Distribution

REFERENCE : H-P-RP-AI-0040

DATE : 29/SEP/06

ISSUE : 06

Page : 373/405

PLANCK – CASE C BOL SURVIVAL

SHEAR PANEL – FOG/CRU

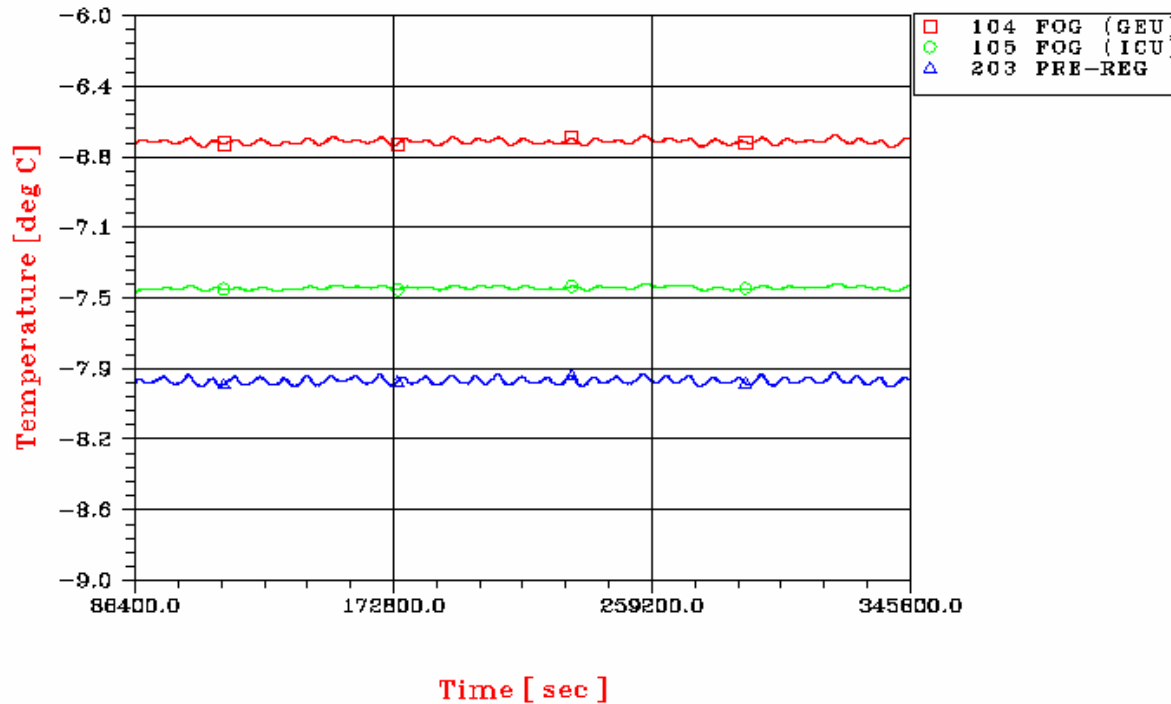

Controlled Distribution

REFERENCE : H-P-RP-AI-0040

DATE : 29/SEP/06

ISSUE : 06

Page : 374/405

PLANCK – CASE C BOL SURVIVAL

LATERAL PANEL +Y

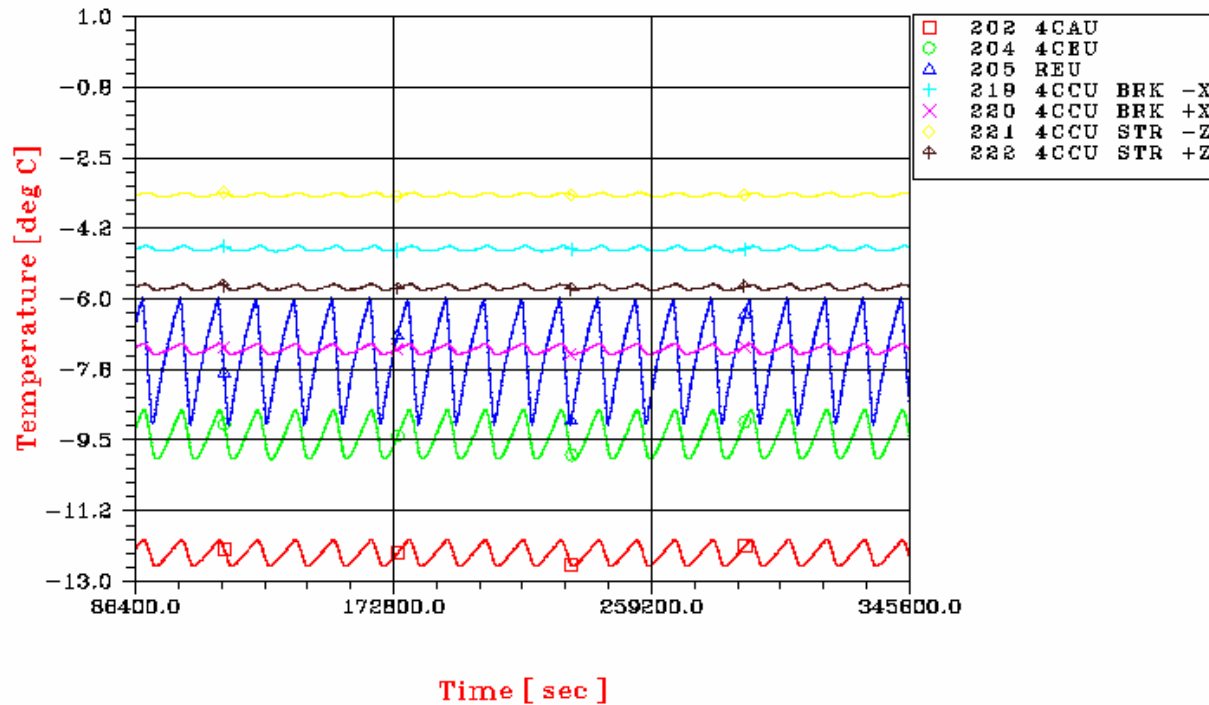

Controlled Distribution

REFERENCE : H-P-RP-AI-0040

DATE : 29/SEP/06

ISSUE : 06

Page : 375/405

PLANCK – CASE C BOL SURVIVAL
LATERAL PANEL – Z

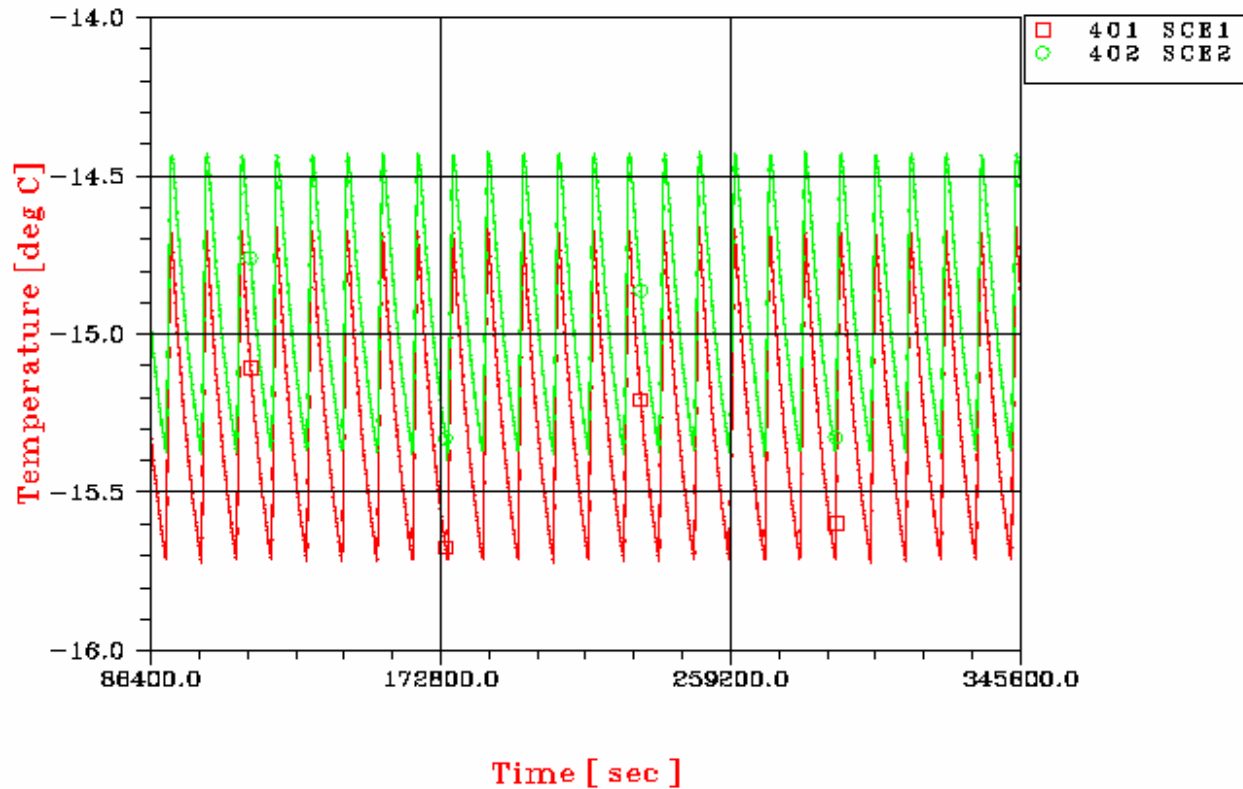

Controlled Distribution

REFERENCE : H-P-RP-AI-0040

DATE : 29/SEP/06

ISSUE : 06

Page : 376/405

PLANCK - CASE C BOL SURVIVAL
SUBPLATFORM +X-X

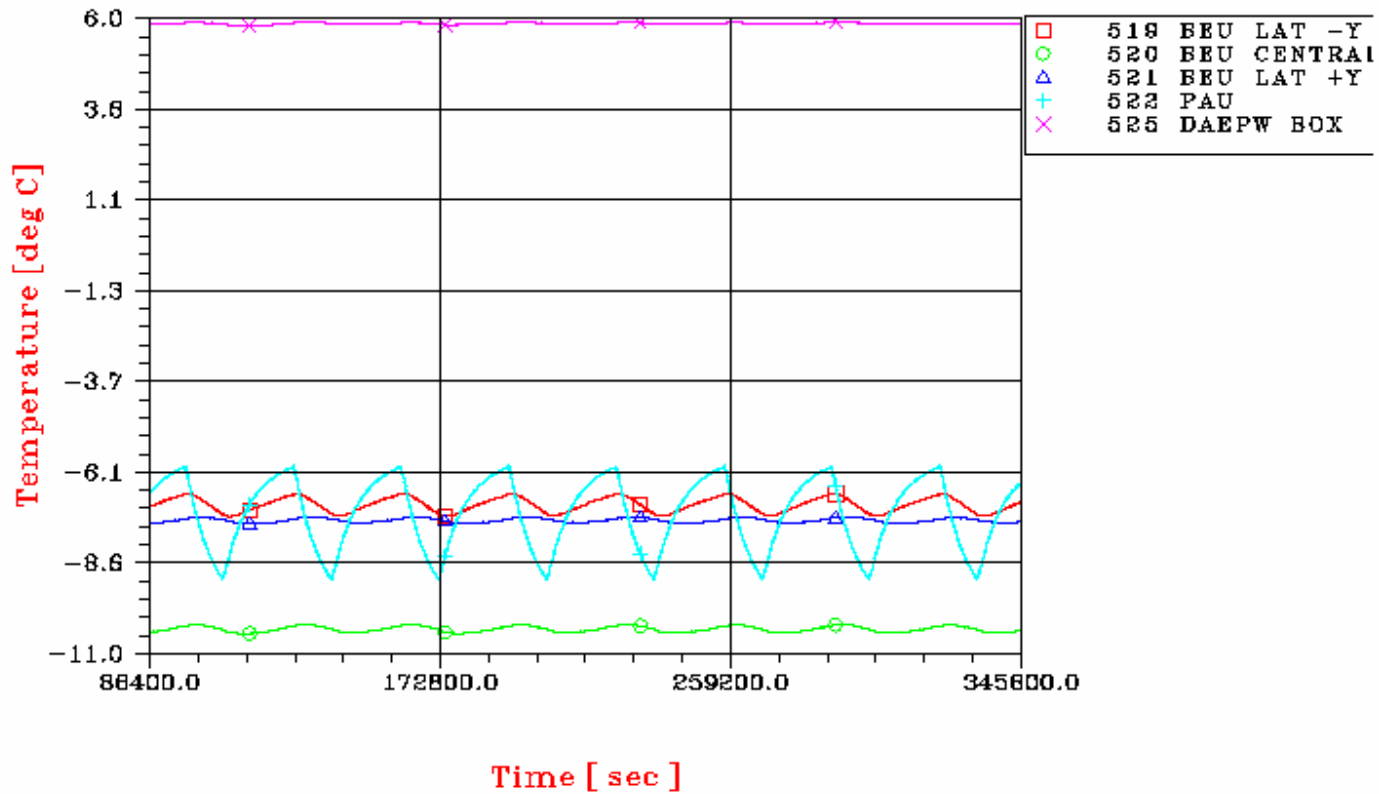

Controlled Distribution

REFERENCE : H-P-RP-AI-0040

DATE : 29/SEP/06

ISSUE : 06

Page : 377/405

PLANCK - CASE C BOL SURVIVAL
LATERAL PANEL - Y

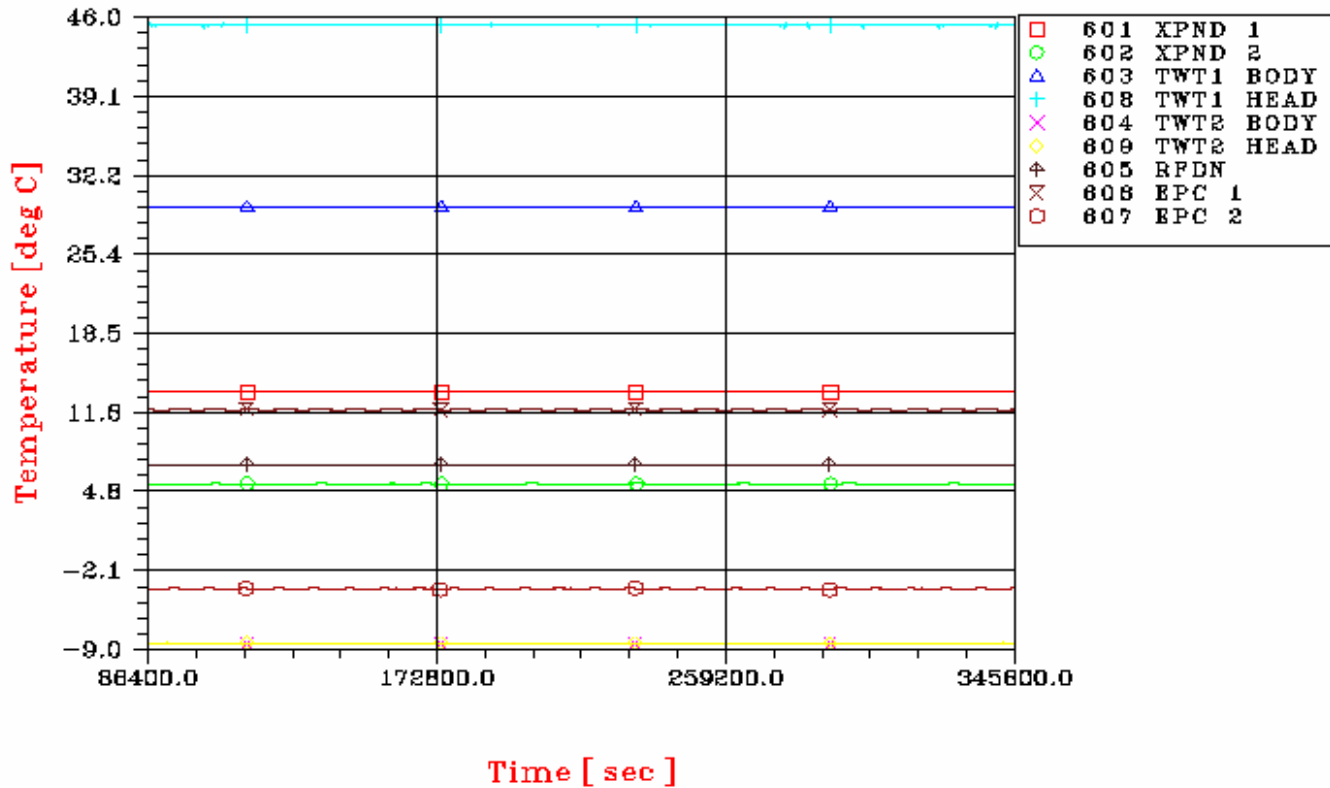

Controlled Distribution

REFERENCE : H-P-RP-AI-0040

DATE : 29/SEP/06

ISSUE : 06

Page : 378/405

**PLANCK – CASE C BOL SURVIVAL
LATERAL PANEL +Z-Y**

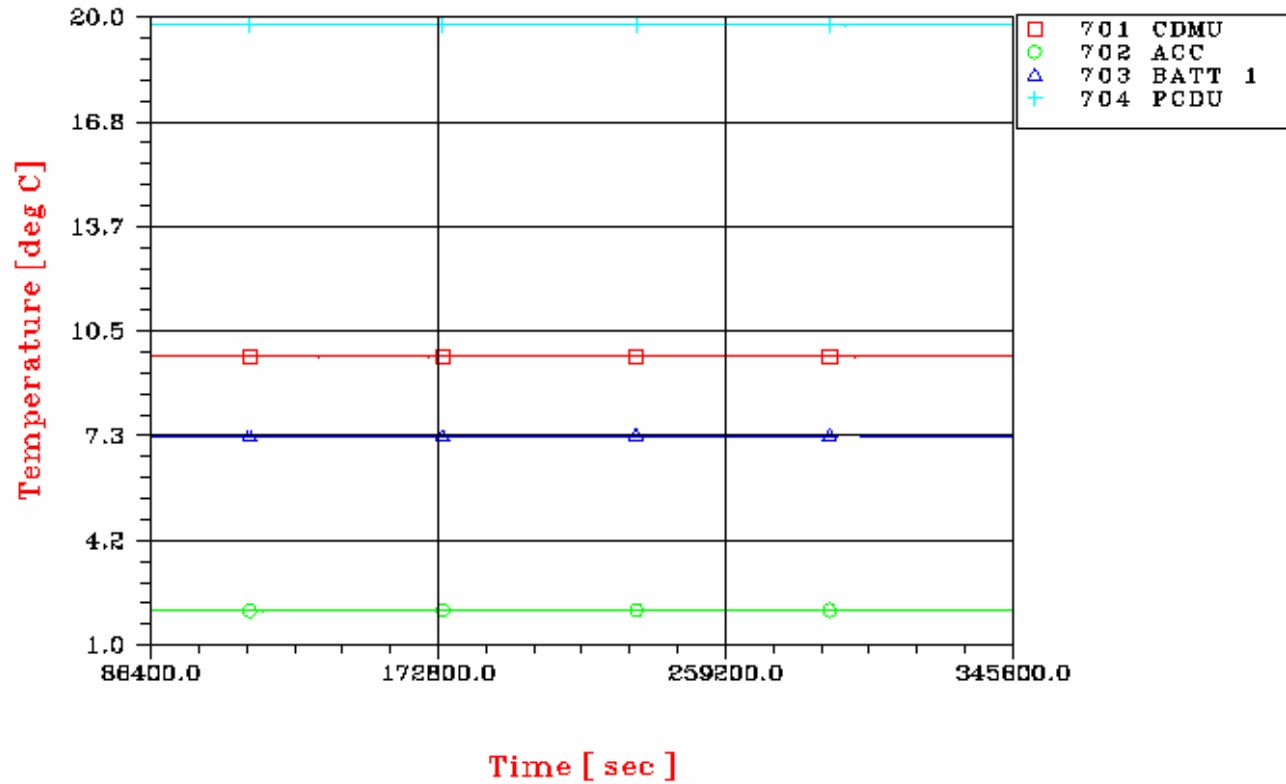

Controlled Distribution

REFERENCE : H-P-RP-AI-0040

DATE : 29/SEP/06

ISSUE : 06

Page : 379/405

PLANCK - CASE C BOL SURVIVAL

SHEAR PANEL - CRS

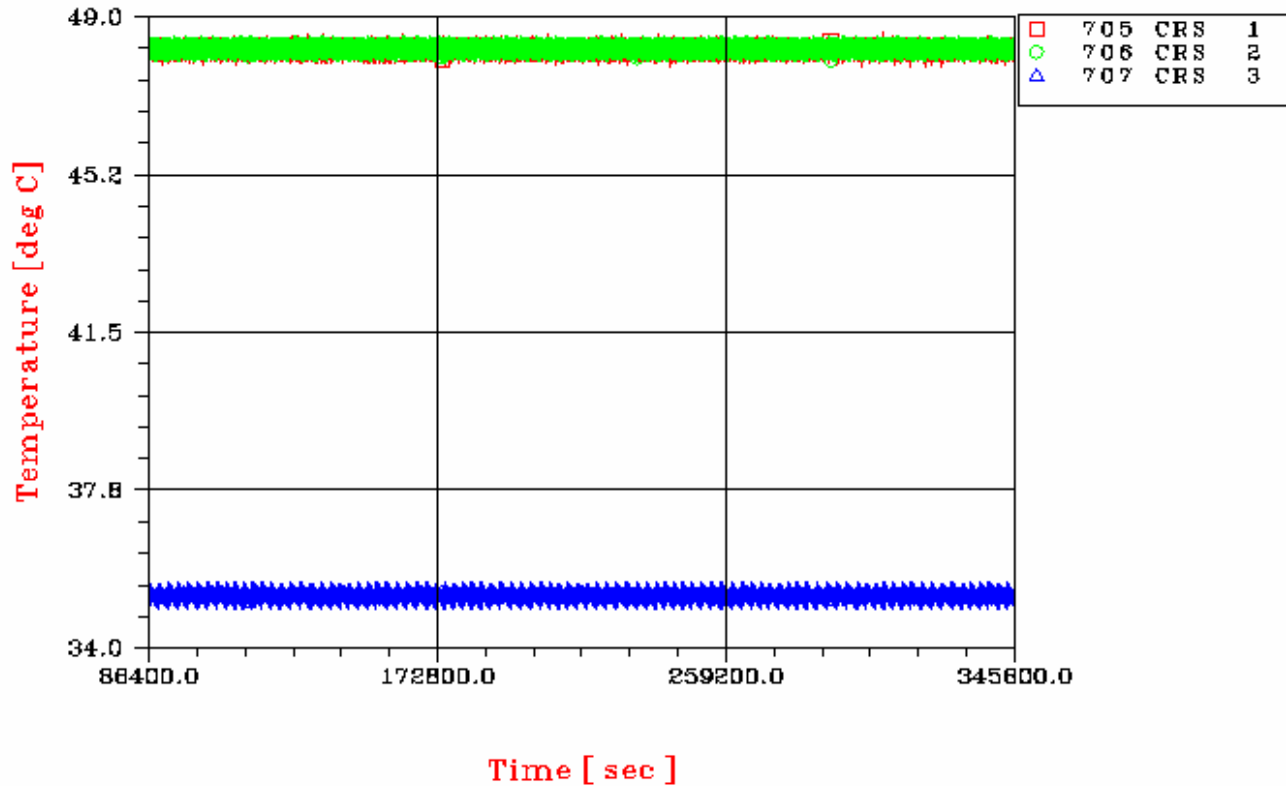

Controlled Distribution

REFERENCE : H-P-RP-AI-0040

DATE : 29/SEP/06

ISSUE : 06

Page : 380/405

PLANCK – CASE C BOL SURVIVAL

SHEAR PANEL – CRS detail

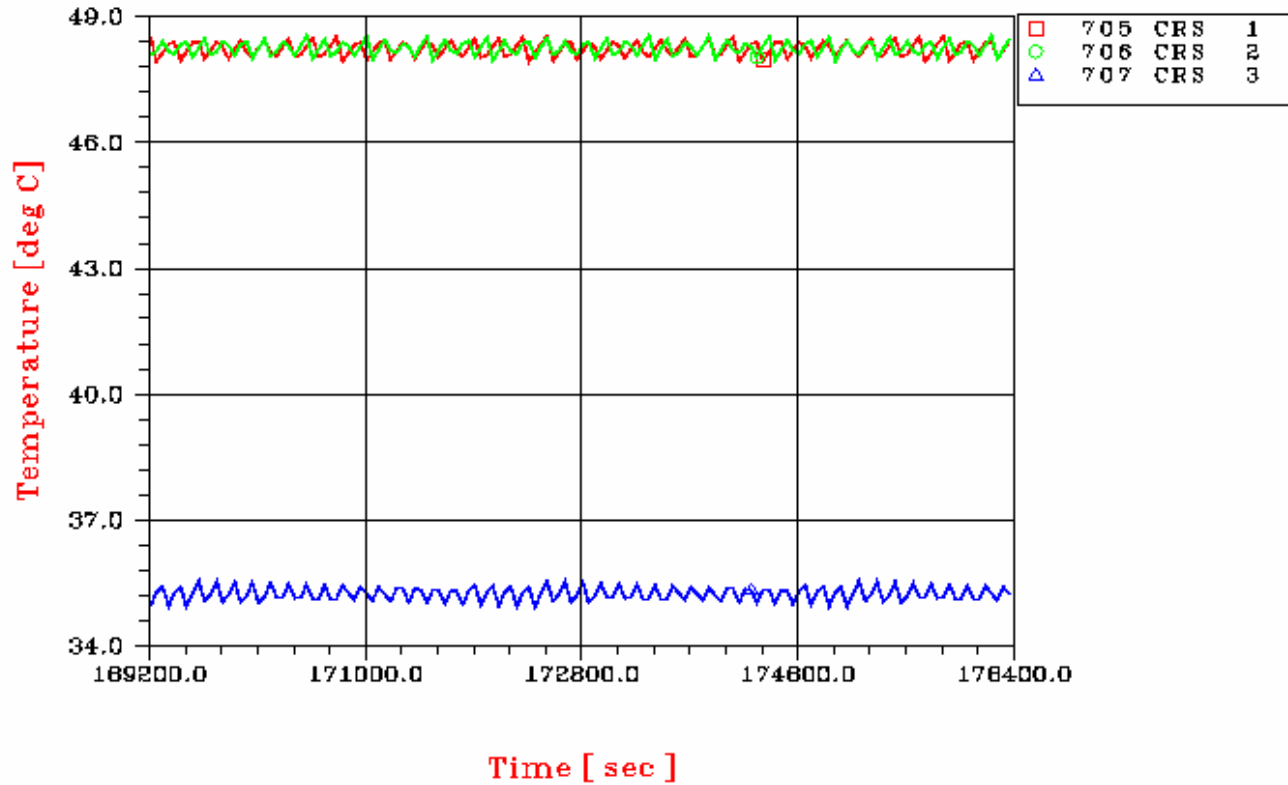

Controlled Distribution

REFERENCE : H-P-RP-AI-0040

DATE : 29/SEP/06

ISSUE : 06

Page : 381/405

**PLANCK - CASE C BOL SURVIVAL
PROPELLANT TANK**

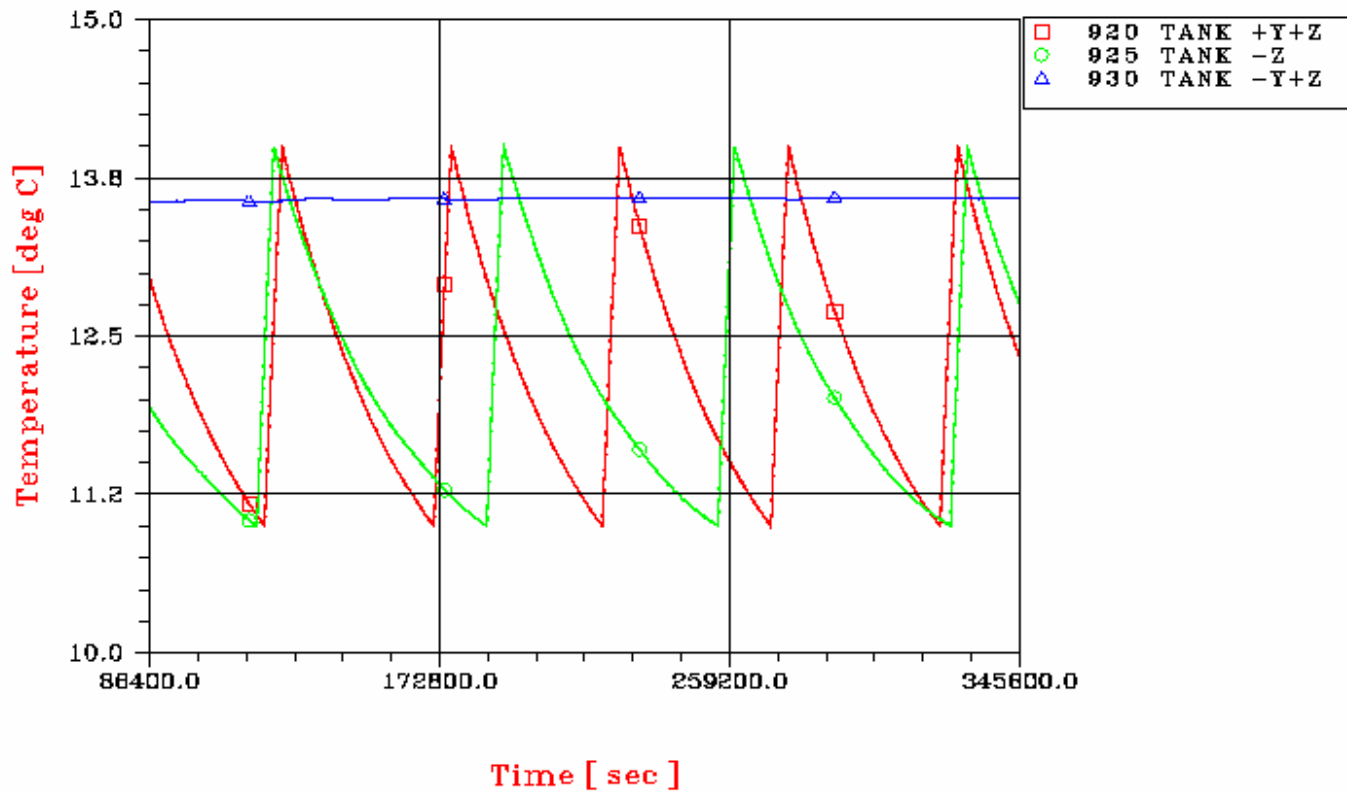

Controlled Distribution

REFERENCE : H-P-RP-AI-0040

DATE : 29/SEP/06

ISSUE : 06

Page : 382/405

**PLANCK – CASE C BOL SURVIVAL
HE TANK**

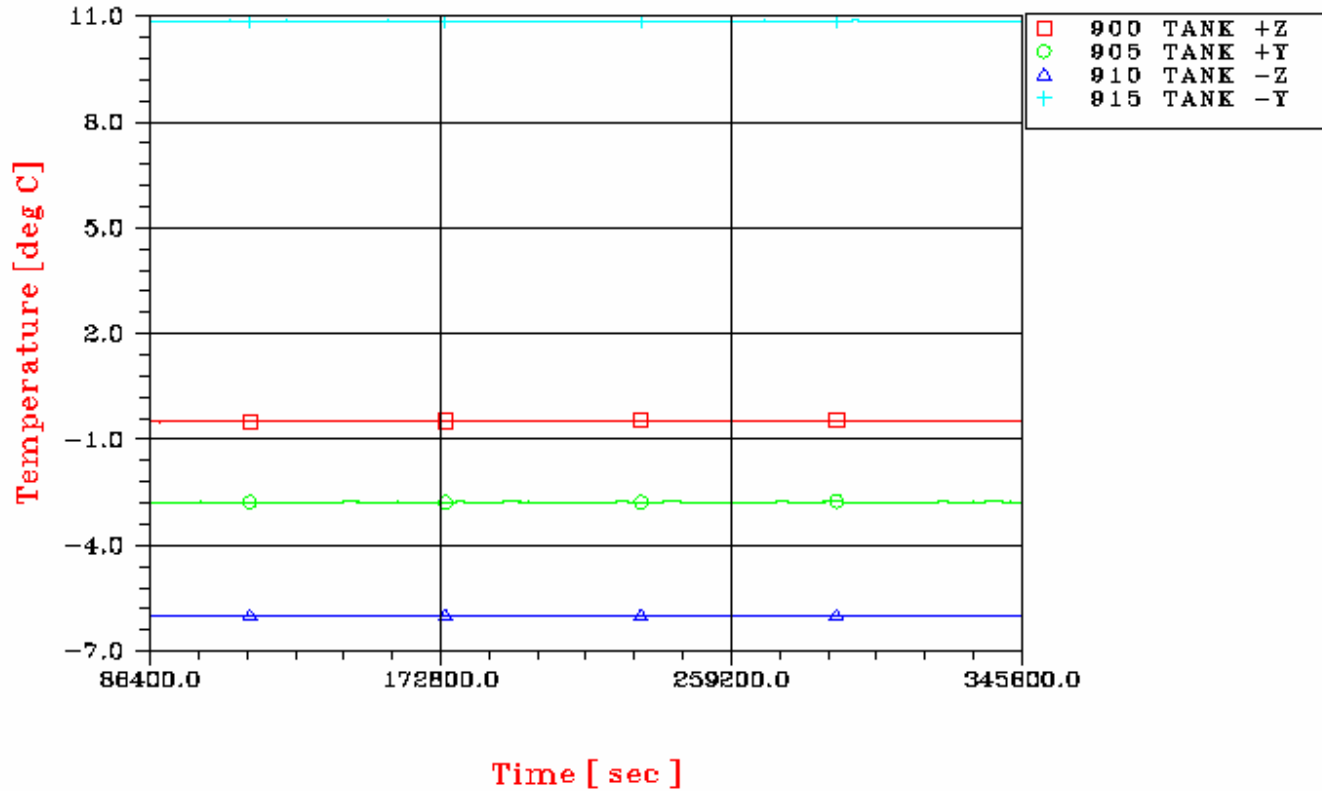

Controlled Distribution

REFERENCE : H-P-RP-AI-0040

DATE : 29/SEP/06

ISSUE : 06

Page : 383/405

PLANCK – CASE C BOL SURVIVAL

SCC1 ON

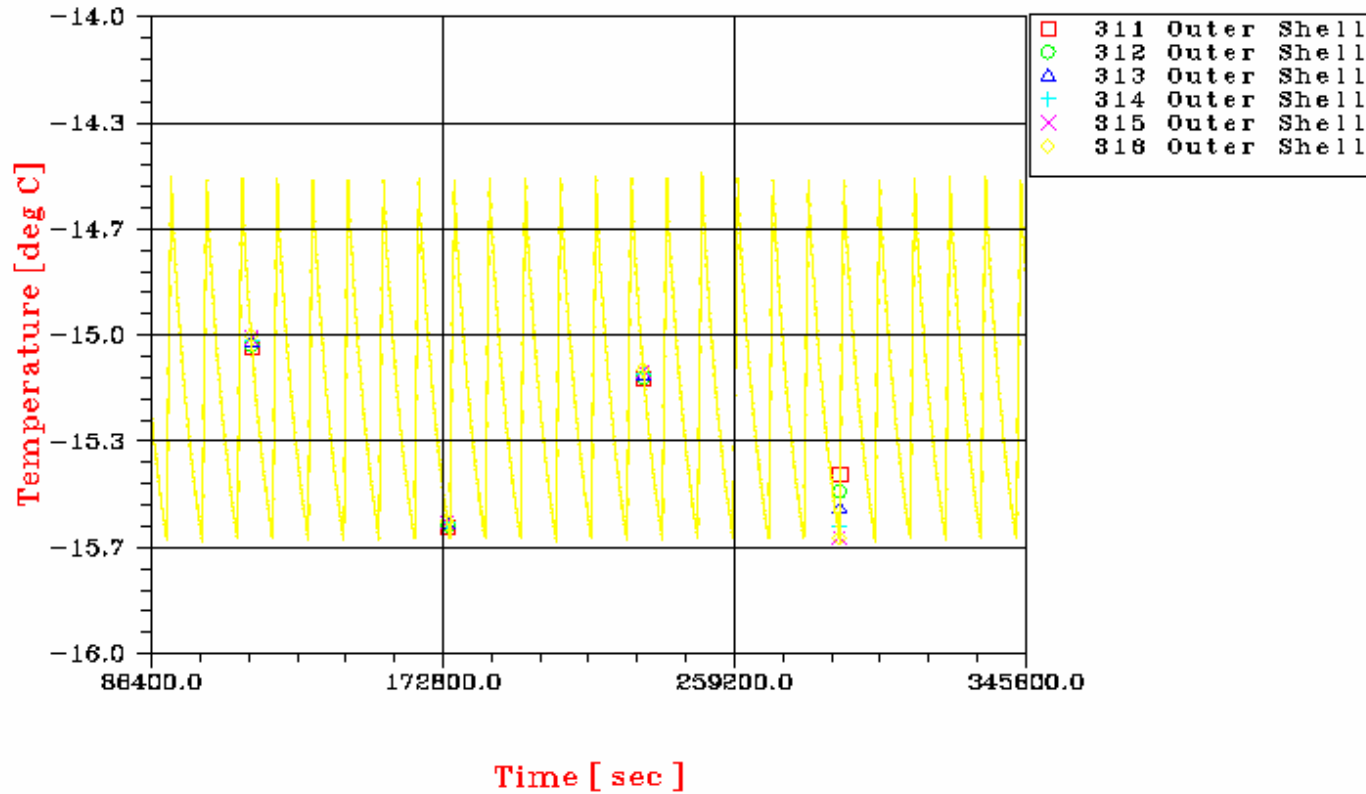

Controlled Distribution

REFERENCE : H-P-RP-AI-0040

DATE : 29/SEP/06

ISSUE : 06

Page : 384/405

PLANCK – CASE C BOL SURVIVAL

SCC1 ON

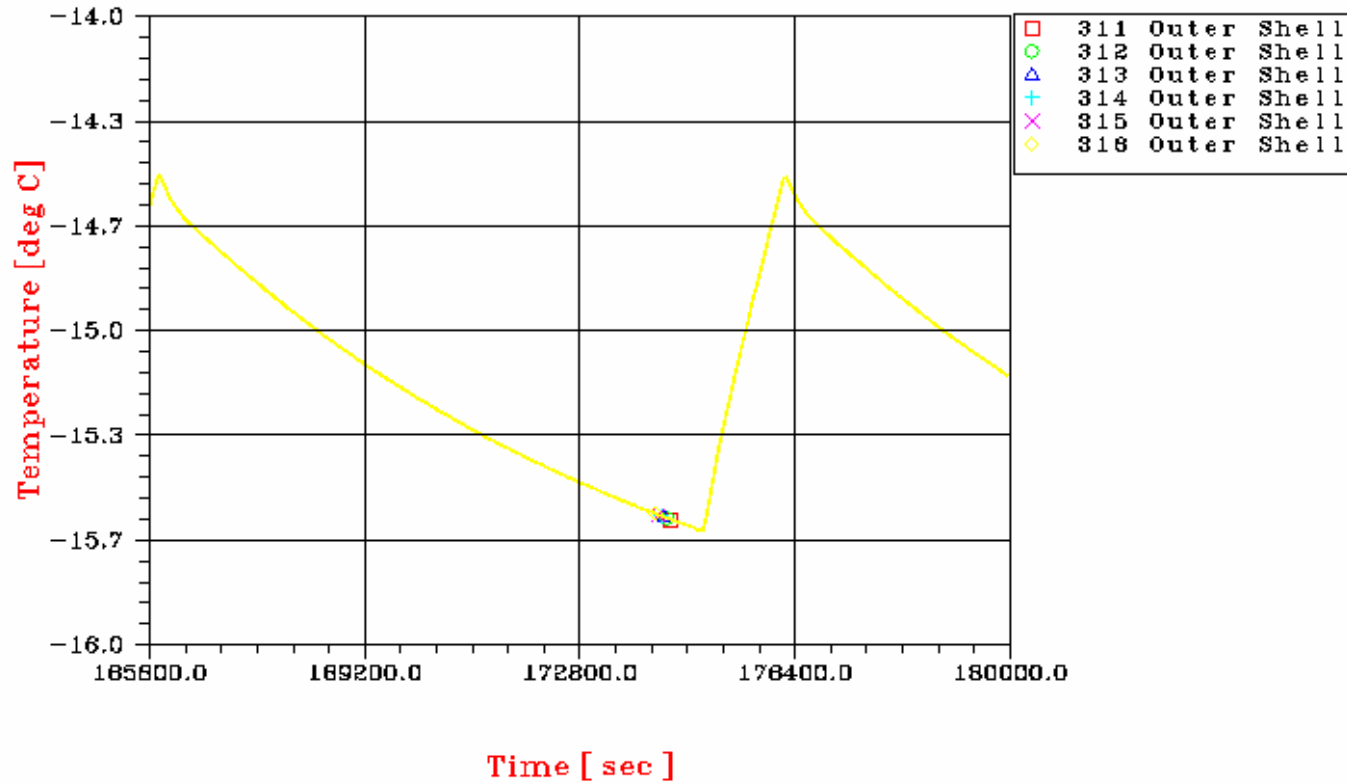

Controlled Distribution

REFERENCE : H-P-RP-AI-0040

DATE : 29/SEP/06

ISSUE : 06

Page : 385/405

PLANCK – CASE C BOL SURVIVAL

SCC1

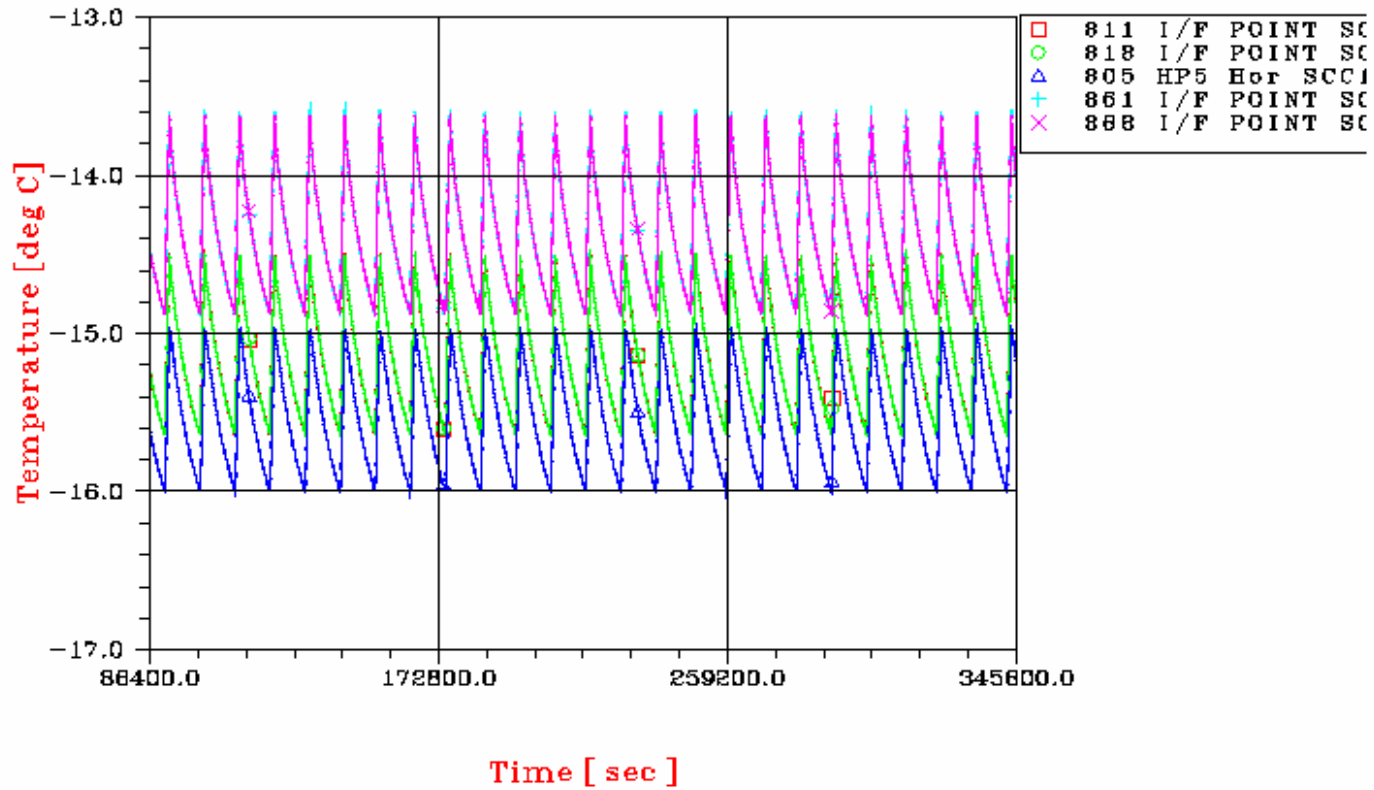

Controlled Distribution

REFERENCE : H-P-RP-AI-0040

DATE : 29/SEP/06

ISSUE : 06

Page : 386/405

PLANCK – CASE C BOL SURVIVAL

SCC1

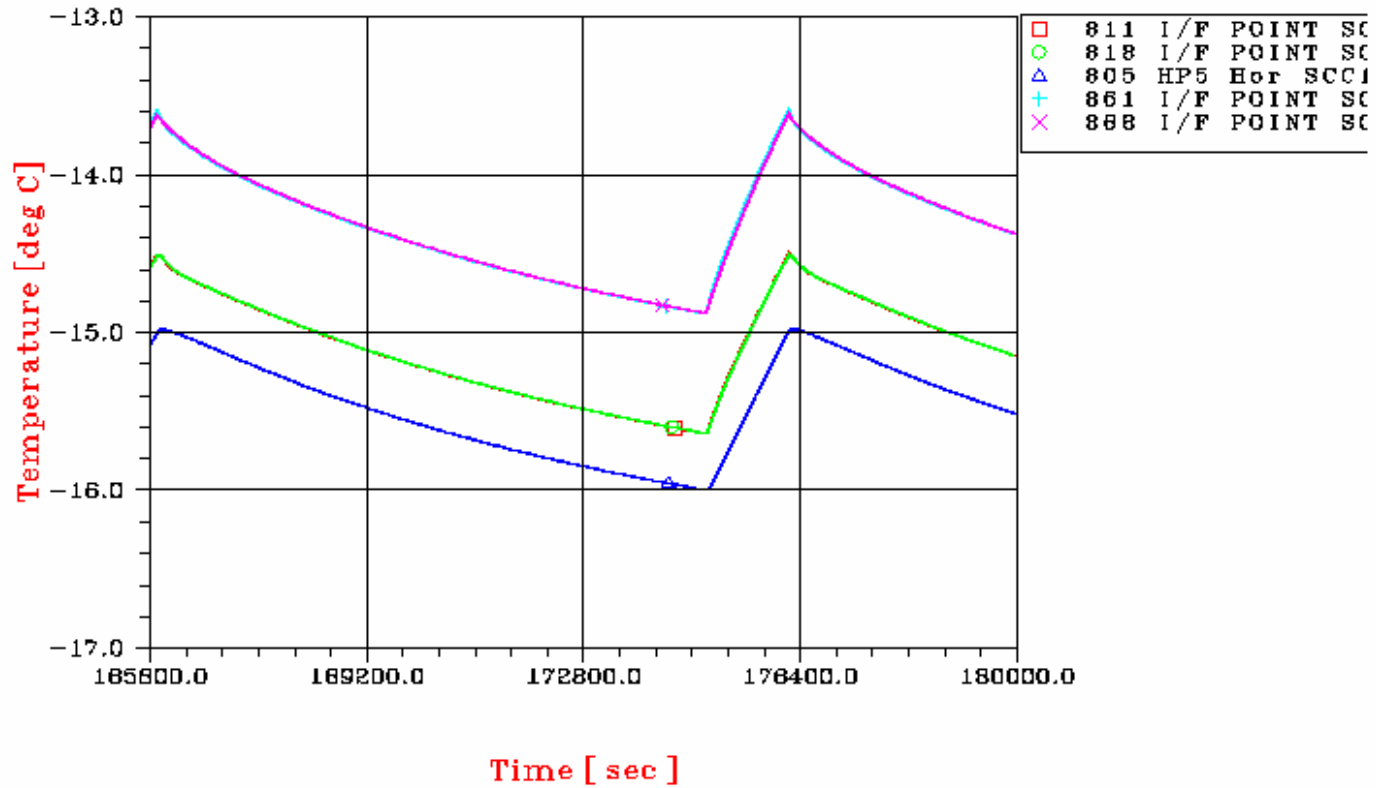

Controlled Distribution

REFERENCE : H-P-RP-AI-0040

DATE : 29/SEP/06

ISSUE : 06

Page : 387/405

PLANCK – CASE C BOL SURVIVAL
SCC2 OFF

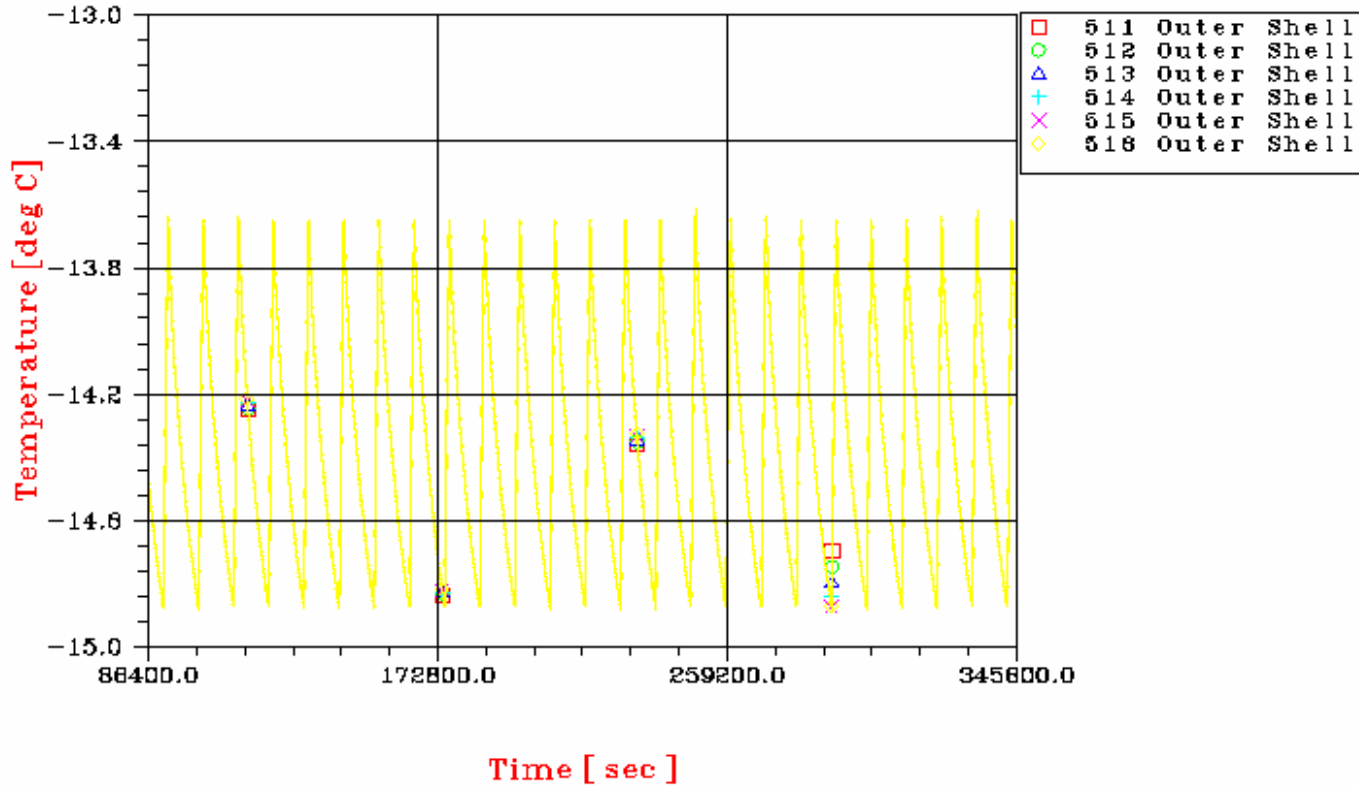

Controlled Distribution

REFERENCE : H-P-RP-AI-0040

DATE : 29/SEP/06

ISSUE : 06

Page : 388/405

PLANCK CASE C SURVIVAL

RCS line #32

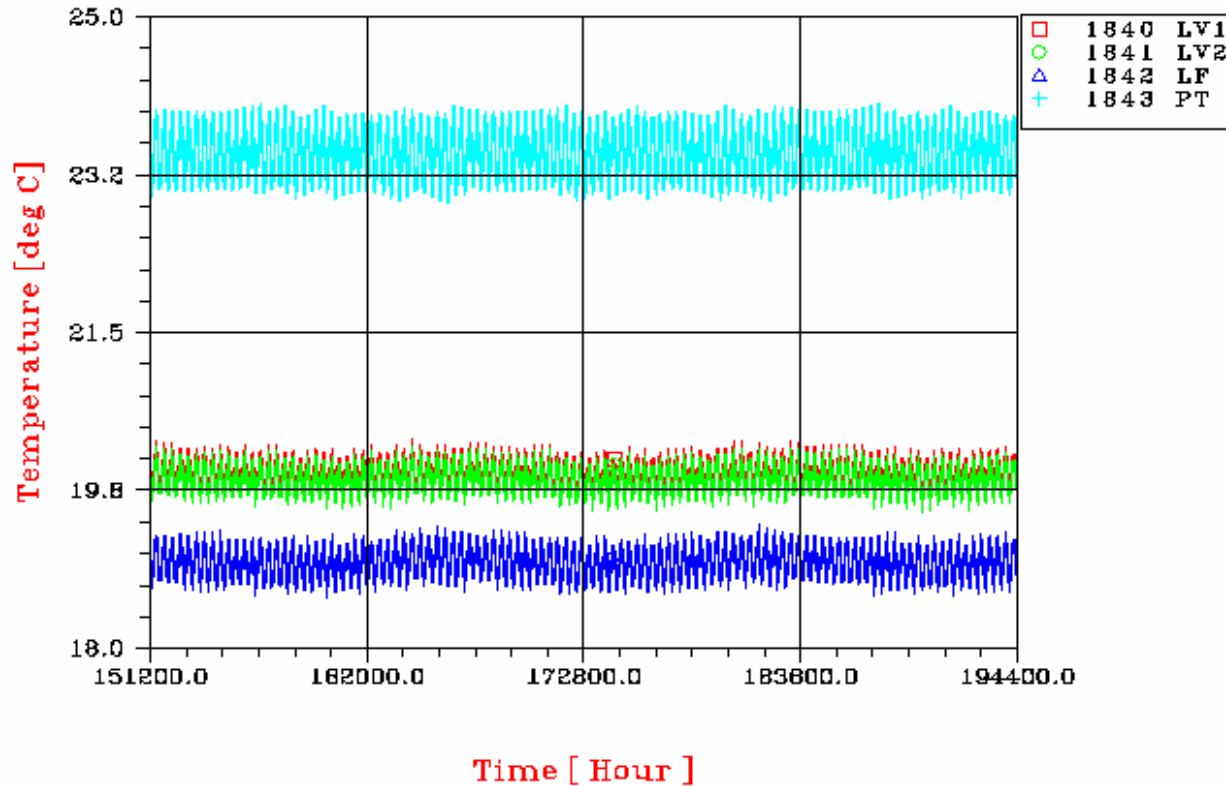

Controlled Distribution

REFERENCE : H-P-RP-AI-0040

DATE : 29/SEP/06

ISSUE : 06

Page : 389/405

PLANCK CASE C SURVIVAL

RCS line #33

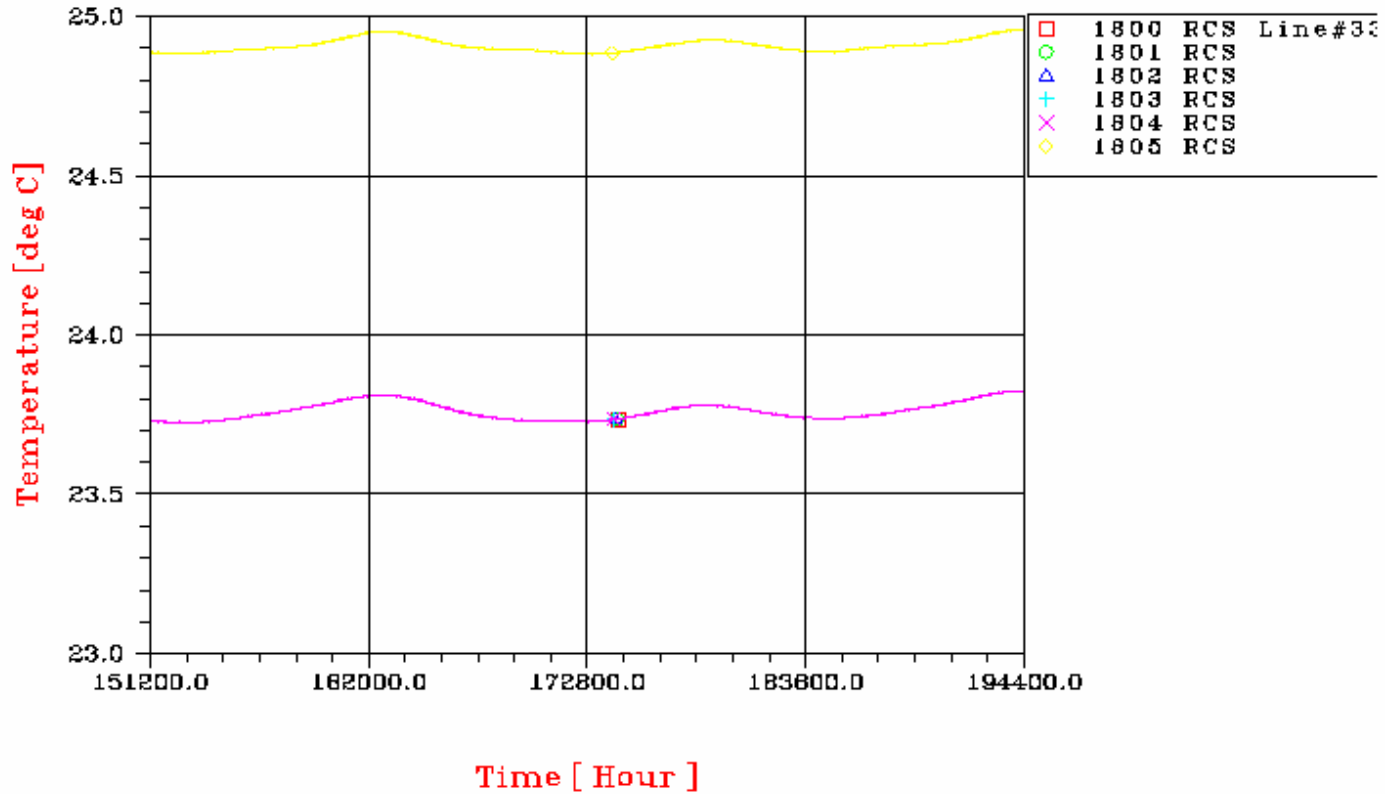

Controlled Distribution

REFERENCE : H-P-RP-AI-0040

DATE : 29/SEP/06

ISSUE : 06

Page : 390/405

PLANCK CASE C SURVIVAL

RCS line #33

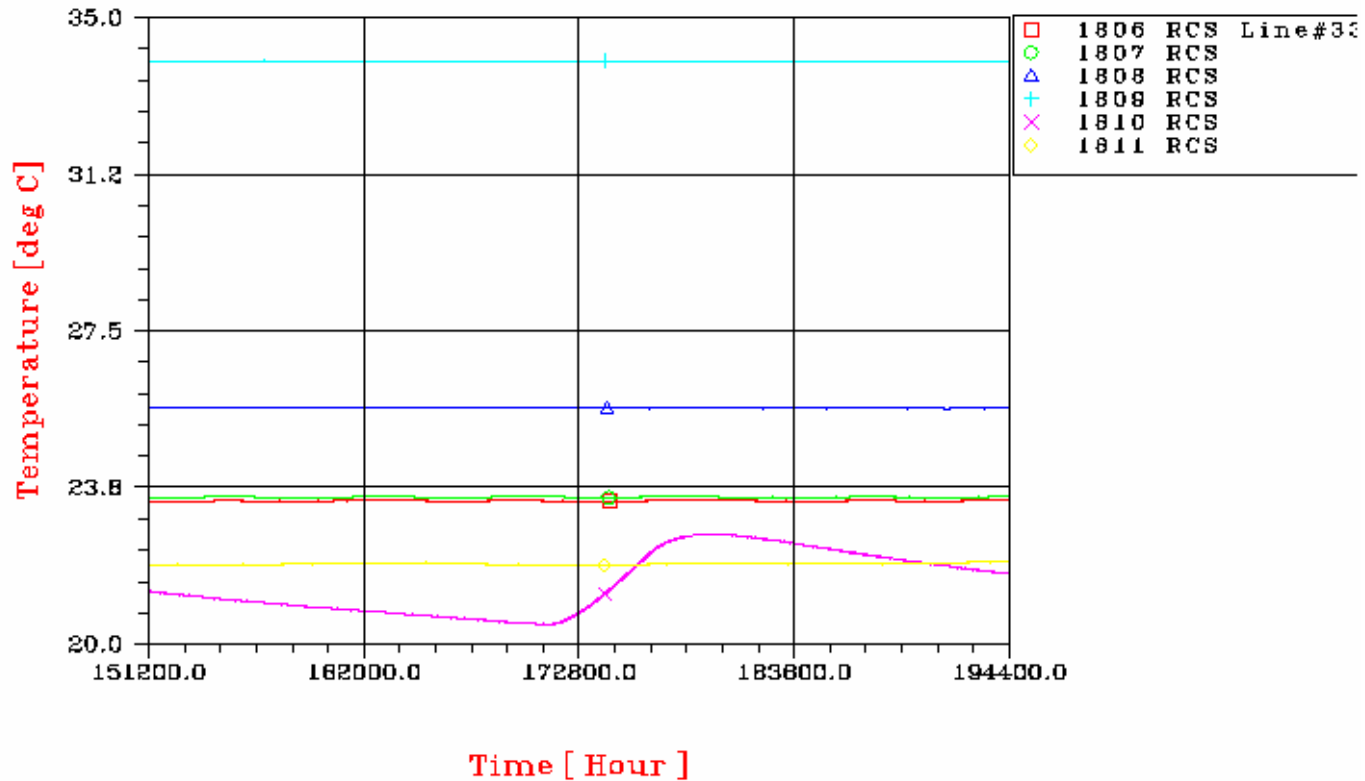

Controlled Distribution

REFERENCE : H-P-RP-AI-0040

DATE : 29/SEP/06

ISSUE : 06

Page : 391/405

PLANCK CASE C SURVIVAL

RCS line #33

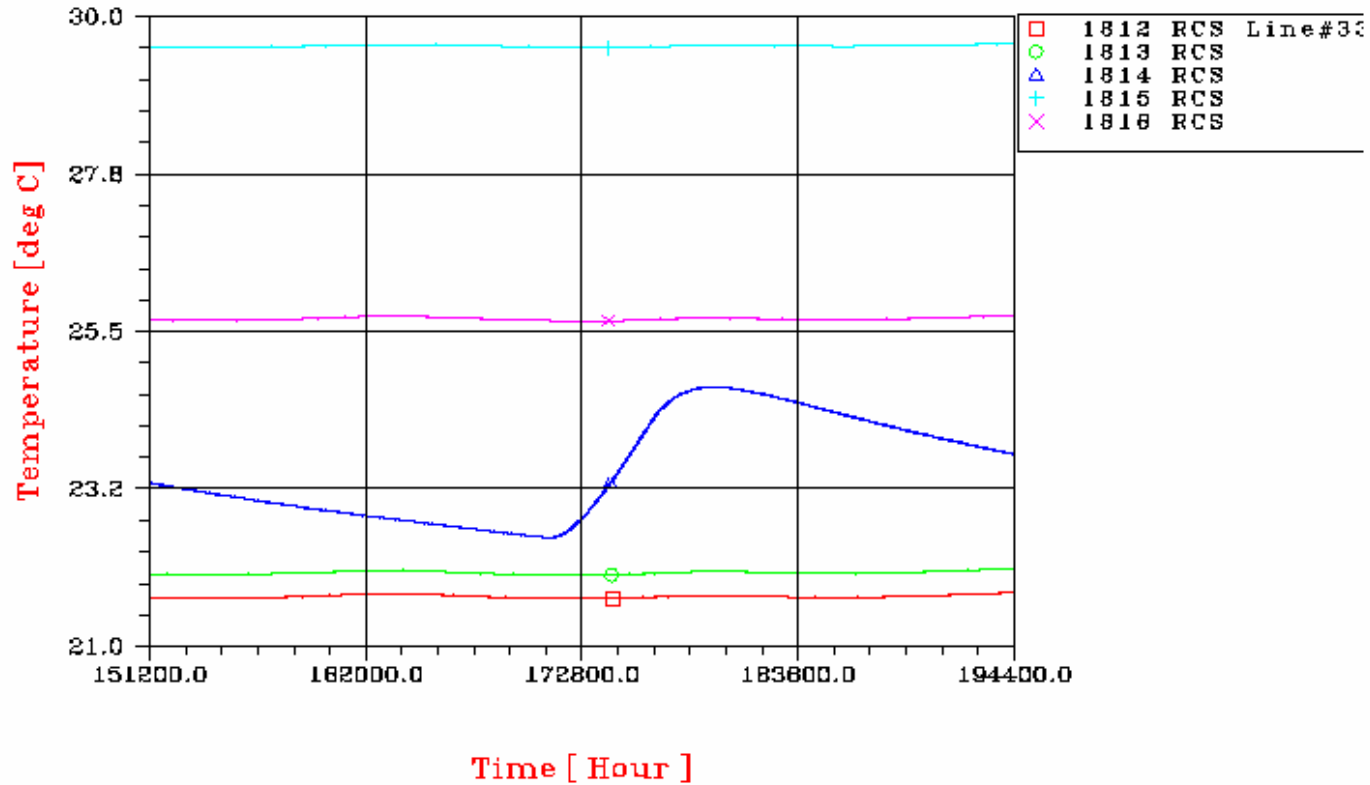

Controlled Distribution

REFERENCE : H-P-RP-AI-0040

DATE : 29/SEP/06

ISSUE : 06

Page : 392/405

PLANCK CASE C SURVIVAL

RCS line #34

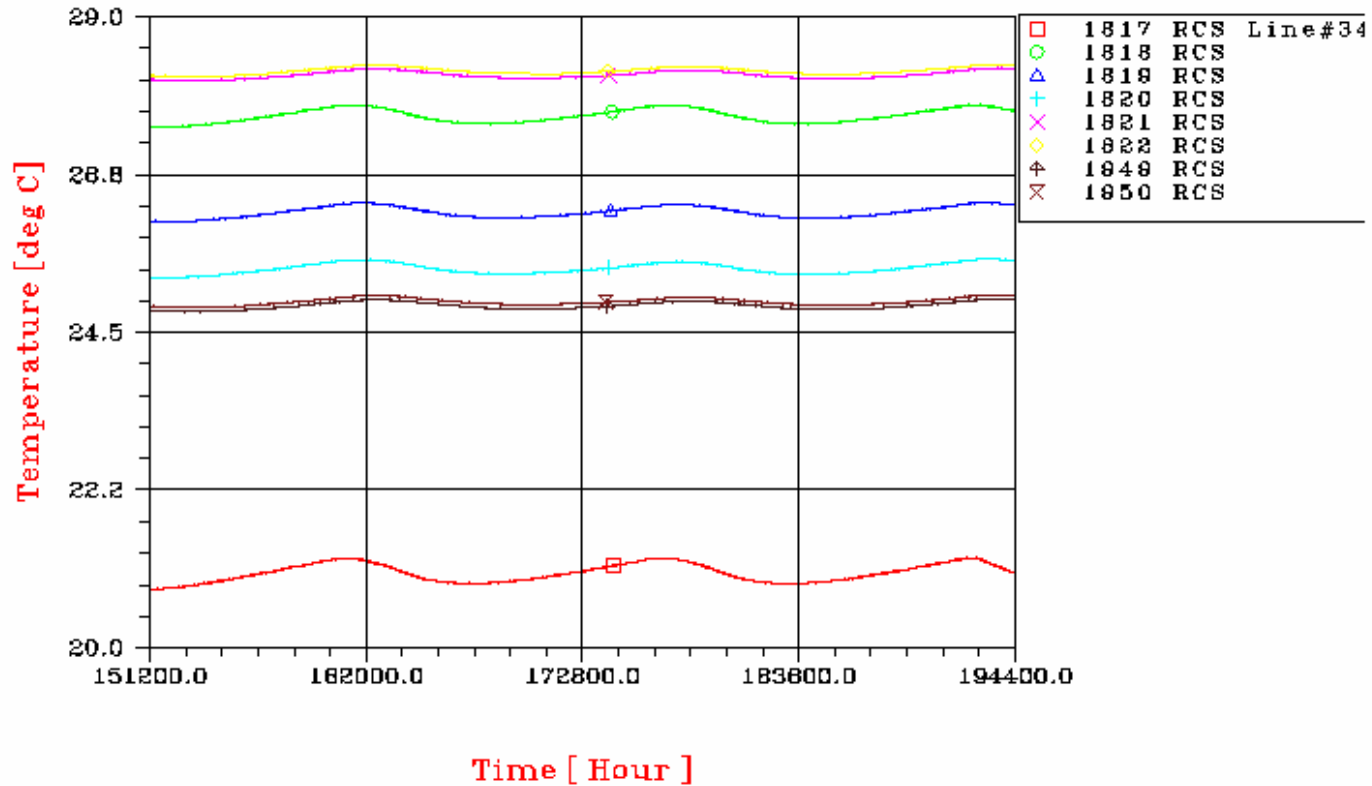

Controlled Distribution

REFERENCE : H-P-RP-AI-0040

DATE : 29/SEP/06

ISSUE : 06

Page : 393/405

PLANCK CASE C SURVIVAL

RCS line #34

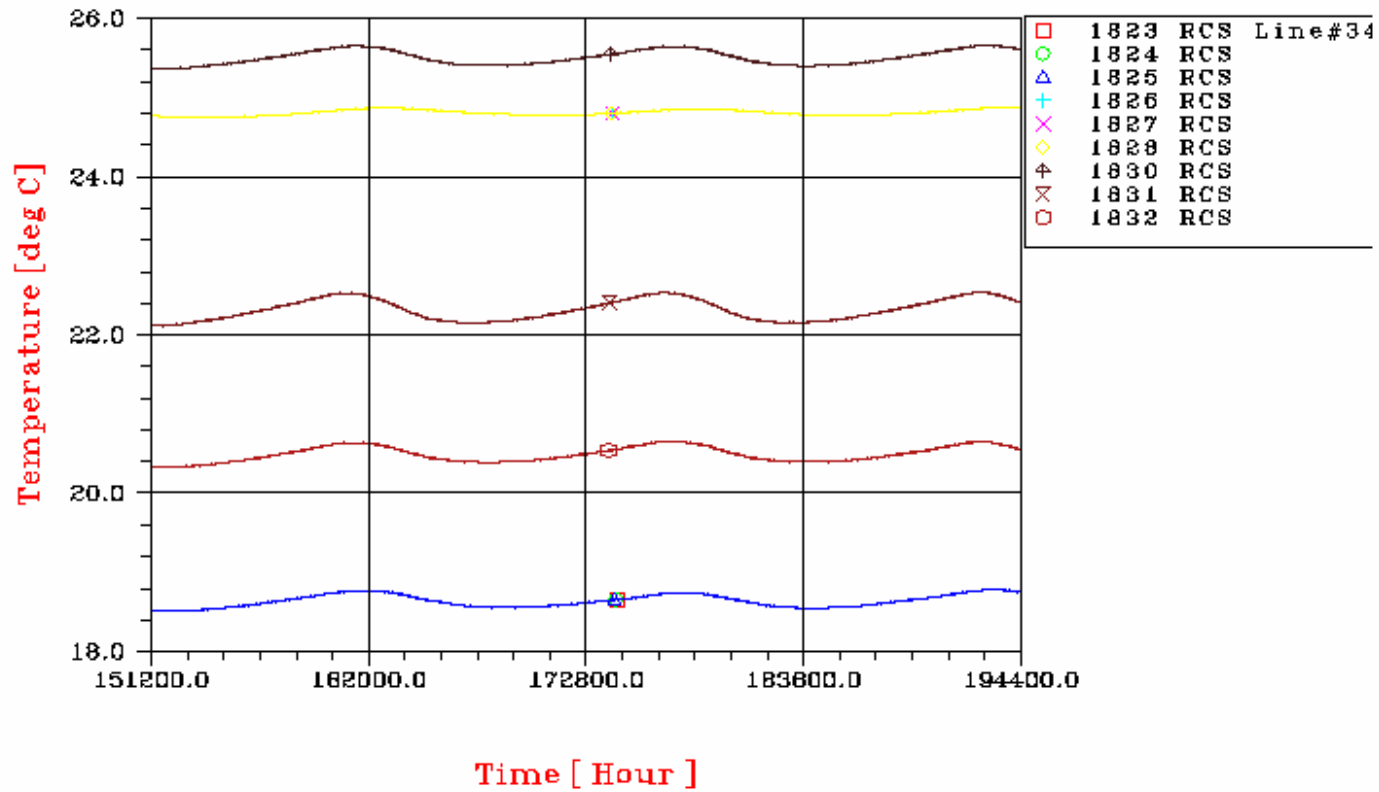

Controlled Distribution

REFERENCE : H-P-RP-AI-0040

DATE : 29/SEP/06

ISSUE : 06

Page : 394/405

PLANCK CASE C SURVIVAL

RCS line #34

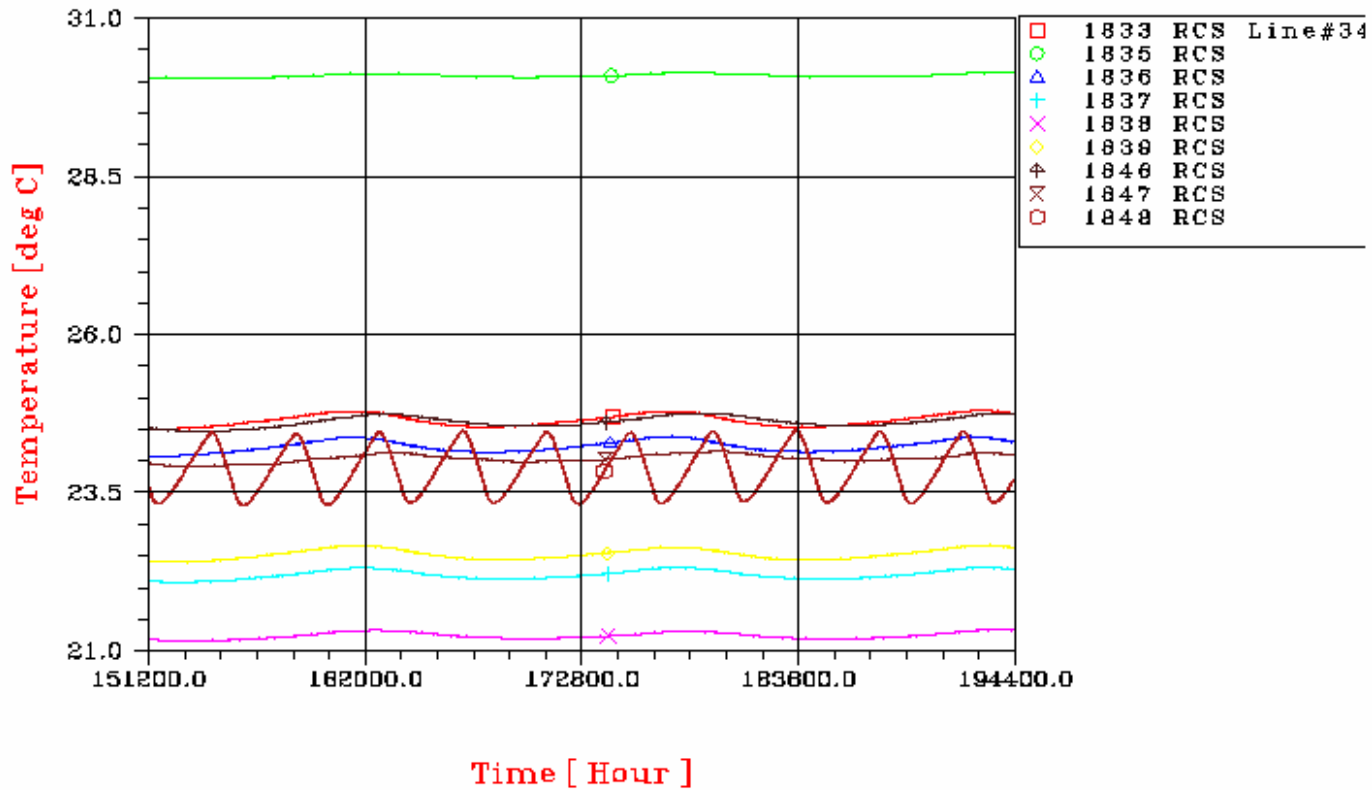

Controlled Distribution

REFERENCE : H-P-RP-AI-0040

DATE : 29/SEP/06

ISSUE : 06

Page : 395/405

PLANCK CASE C SURVIVAL

RCS line #46

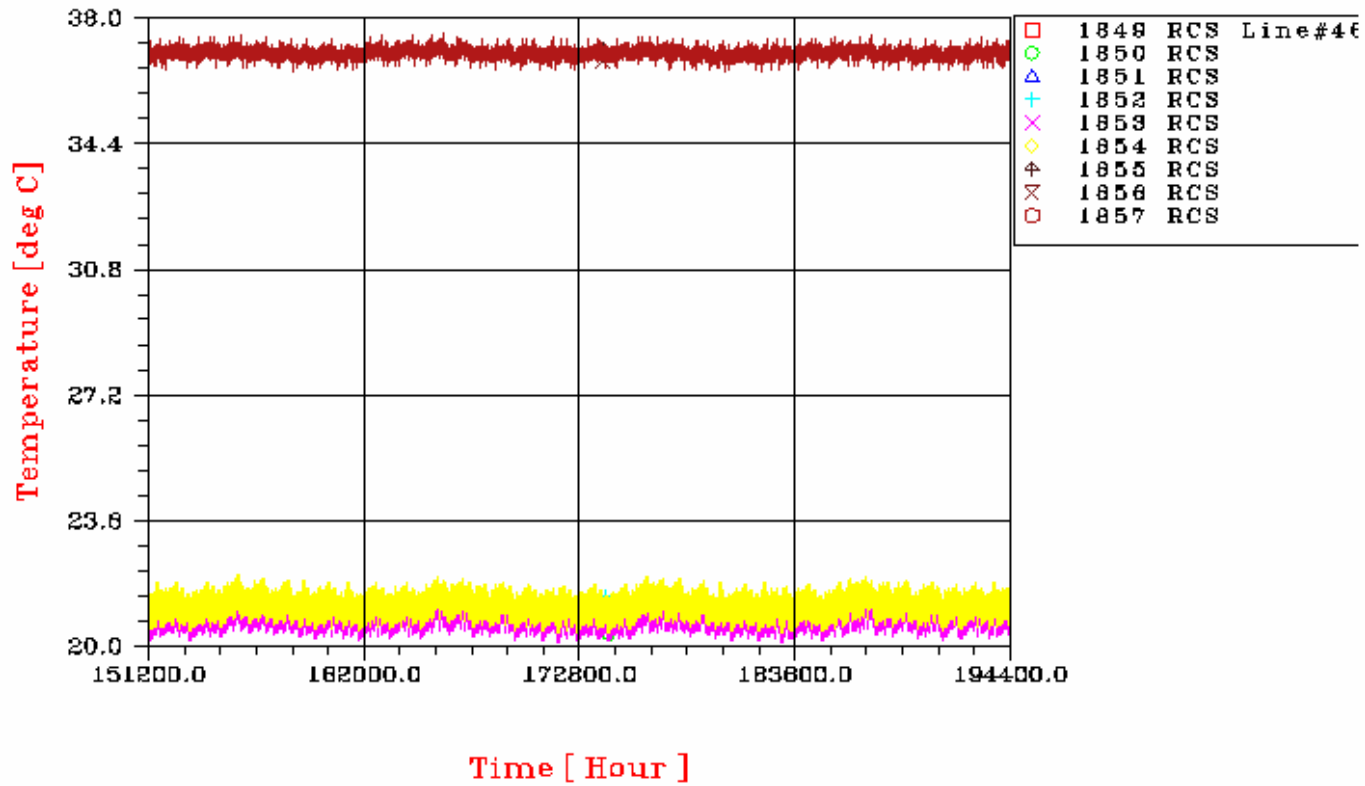

Controlled Distribution

REFERENCE : H-P-RP-AI-0040

DATE : 29/SEP/06

ISSUE : 06

Page : 396/405

PLANCK CASE C SURVIVAL

RCS line #46

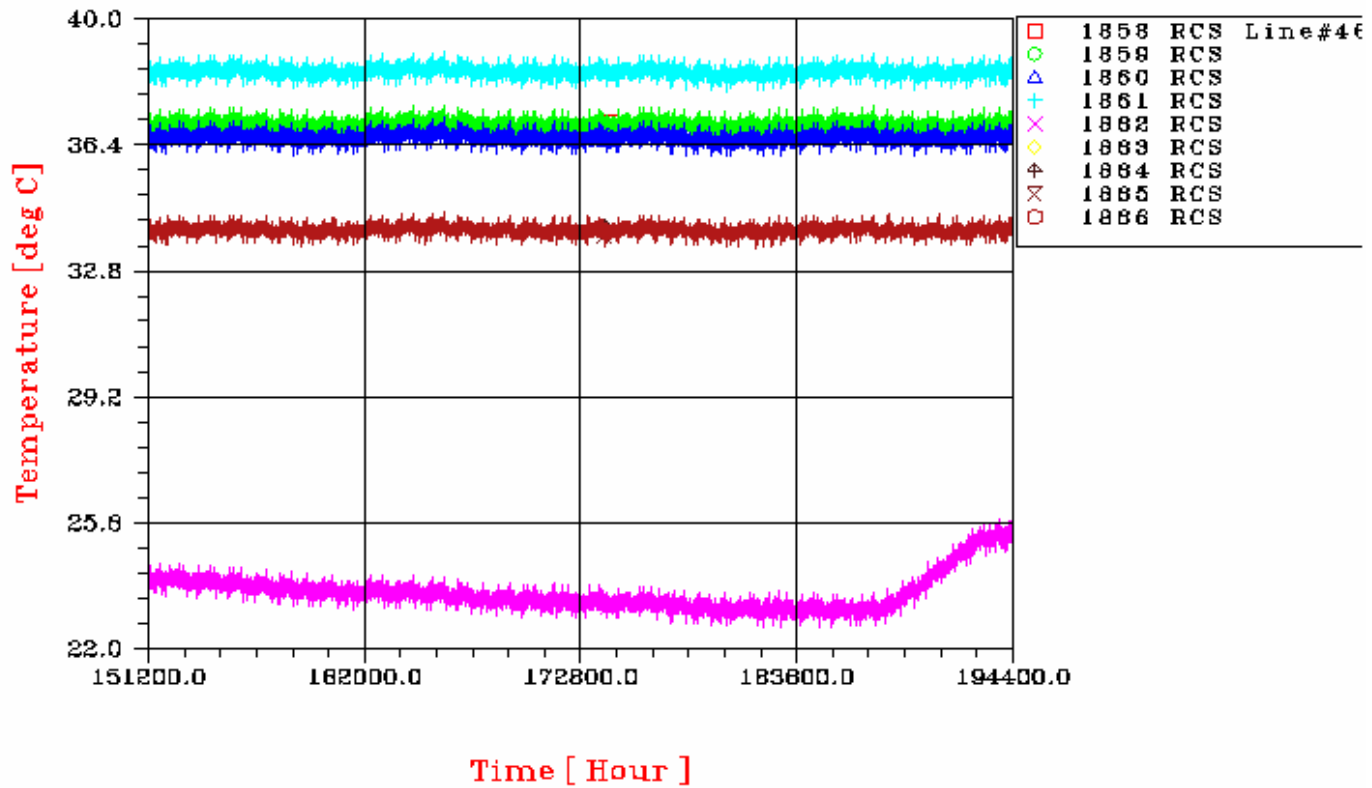

Controlled Distribution

REFERENCE : H-P-RP-AI-0040

DATE : 29/SEP/06

ISSUE : 06

Page : 397/405

PLANCK CASE C SURVIVAL

RCS line #46

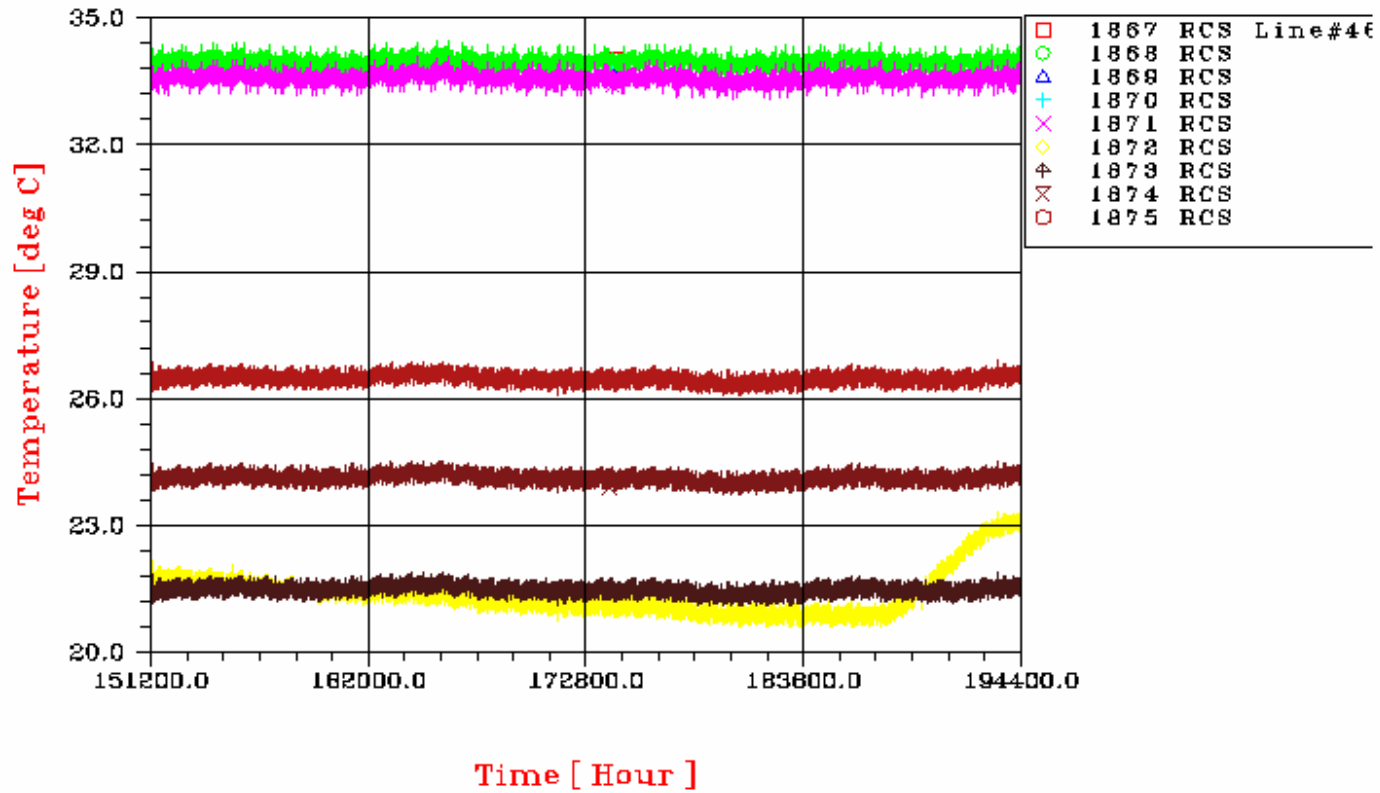

Controlled Distribution

REFERENCE : H-P-RP-AI-0040

DATE : 29/SEP/06

ISSUE : 06

Page : 398/405

PLANCK CASE C SURVIVAL

RCS line #46

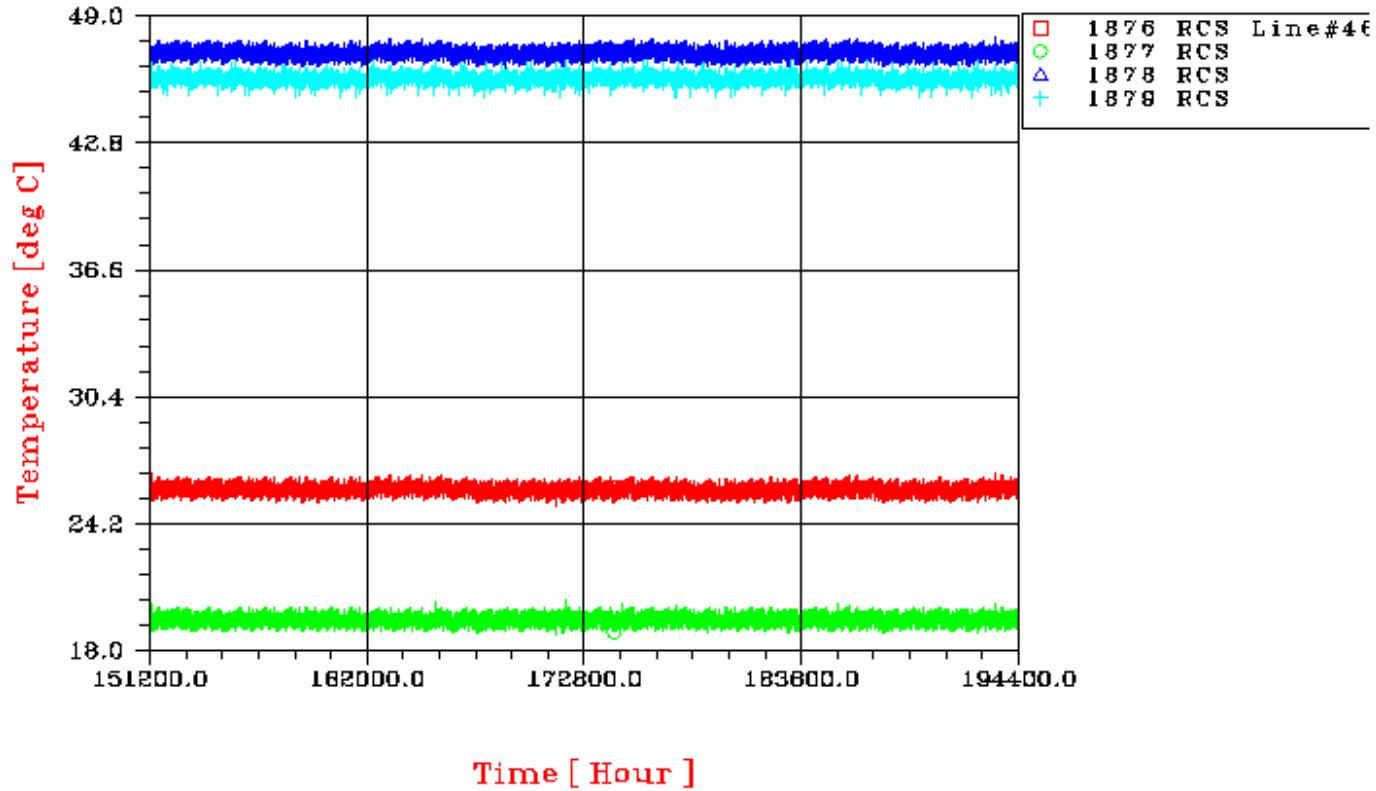

Controlled Distribution

REFERENCE : H-P-RP-AI-0040

DATE : 29/SEP/06

ISSUE : 06

Page : 399/405

PLANCK CASE C SURVIVAL

RCS line #47

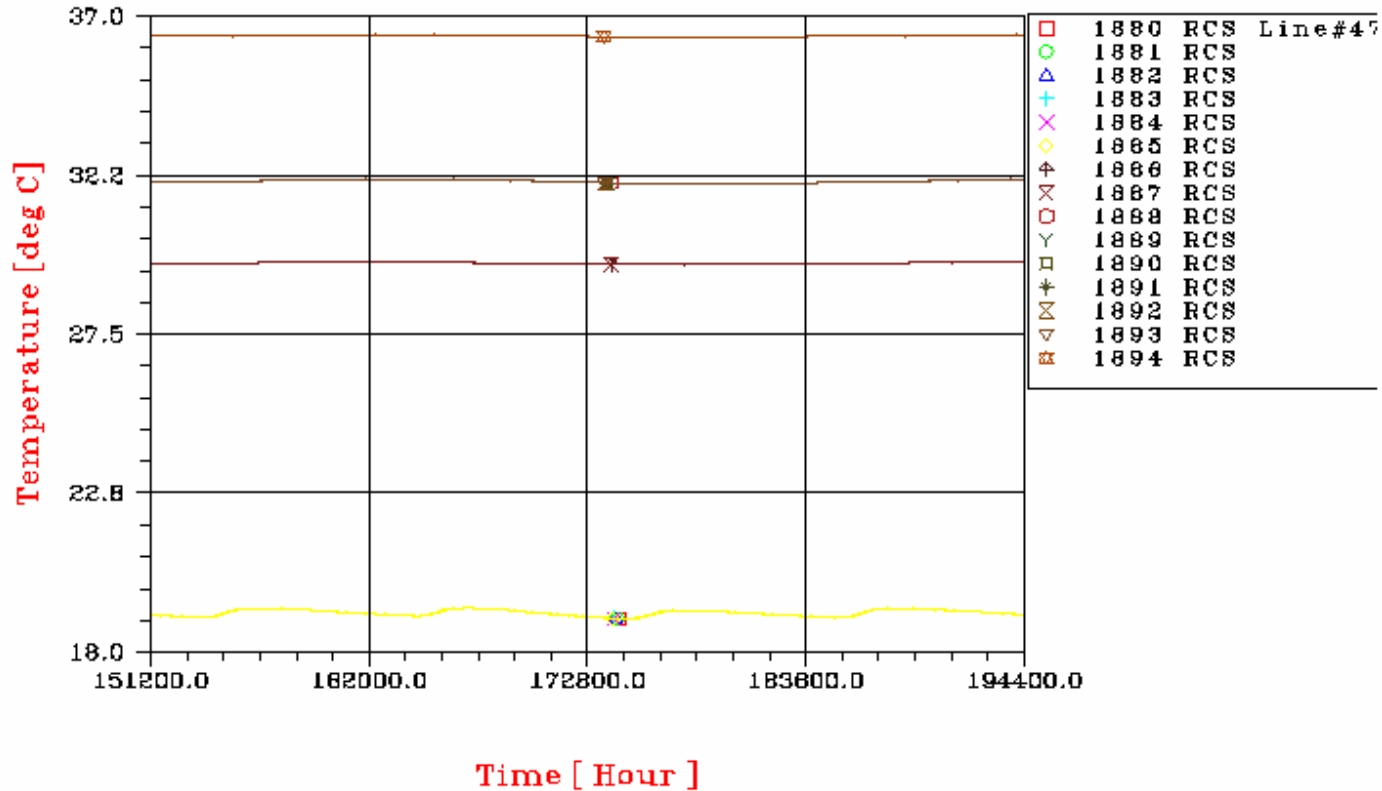

Controlled Distribution

REFERENCE : H-P-RP-AI-0040

DATE : 29/SEP/06

ISSUE : 06

Page : 400/405

PLANCK CASE C SURVIVAL

RCS line #47

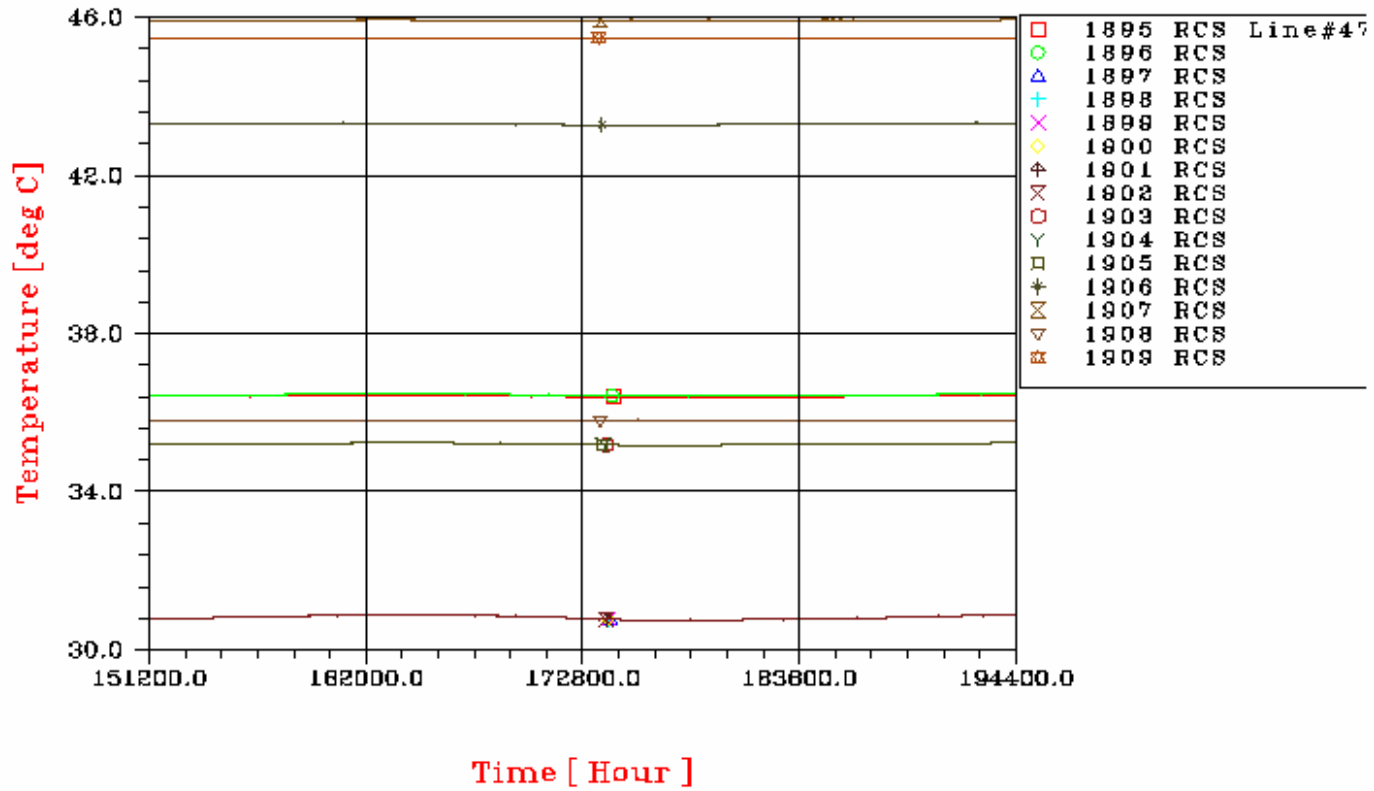

Controlled Distribution

REFERENCE : H-P-RP-AI-0040

DATE : 29/SEP/06

ISSUE : 06

Page : 401/405

PLANCK CASE C SURVIVAL

RCS line #47

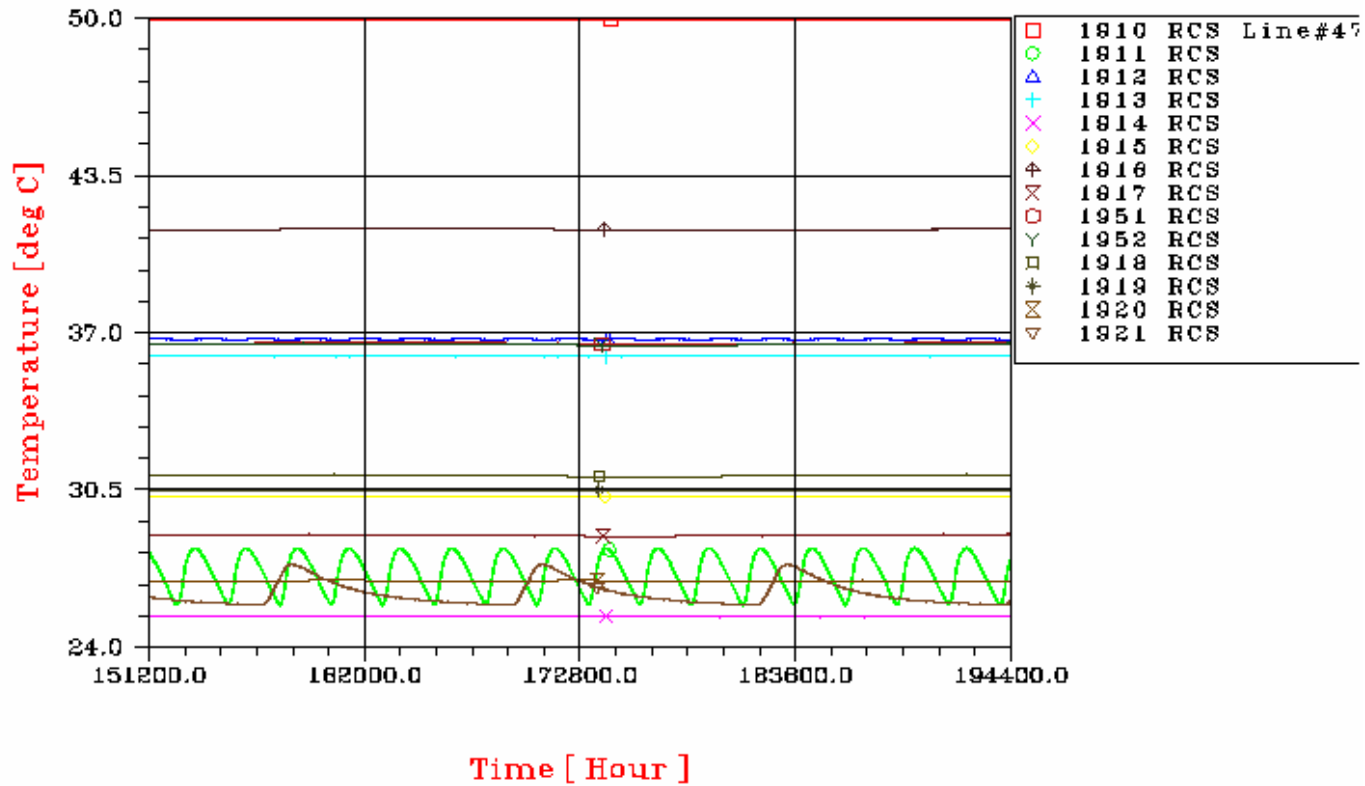

Controlled Distribution

REFERENCE : H-P-RP-AI-0040

DATE : 29/SEP/06

ISSUE : 06

Page : 402/405

PLANCK CASE C SURVIVAL

RCS line #48

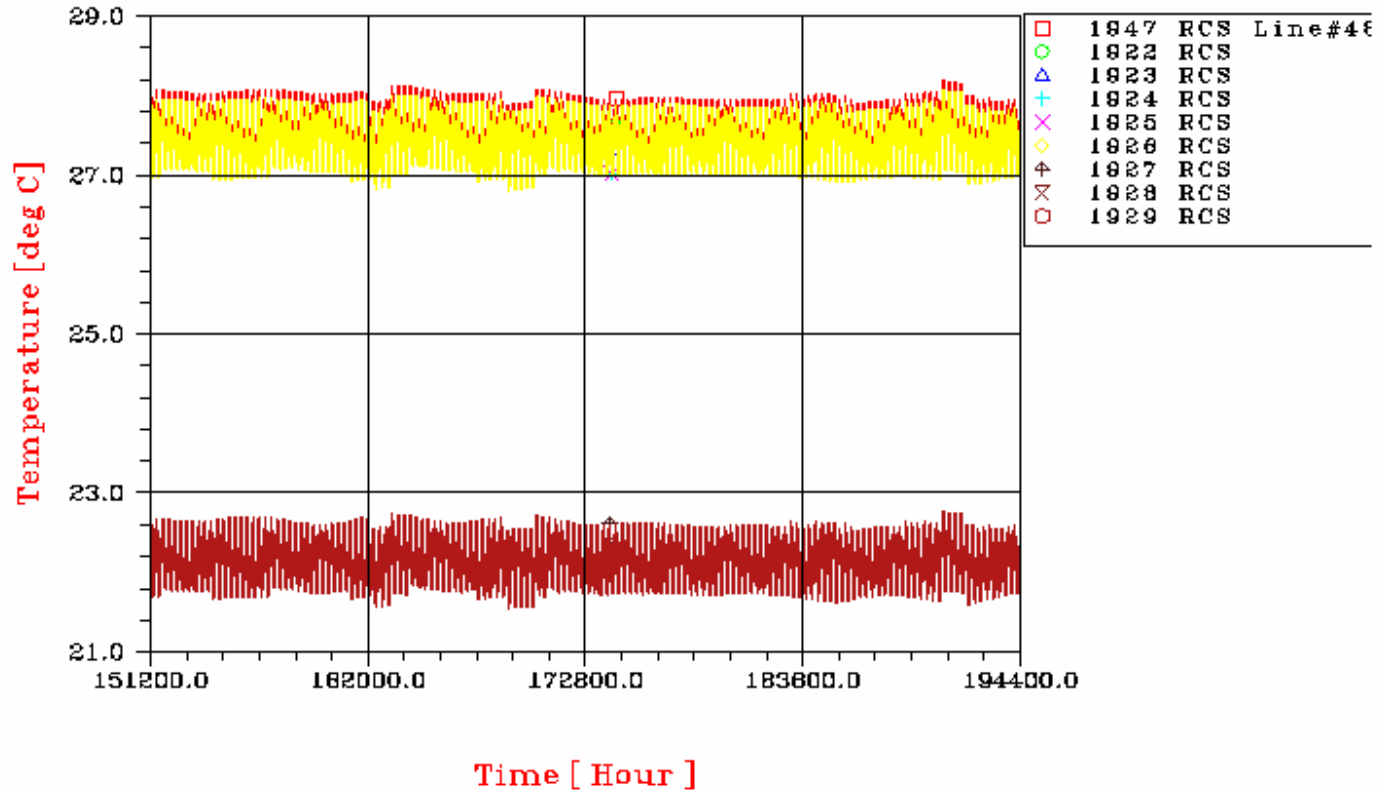

Controlled Distribution

REFERENCE : H-P-RP-AI-0040

DATE : 29/SEP/06

ISSUE : 06

Page : 403/405

PLANCK CASE C SURVIVAL

RCS line #48

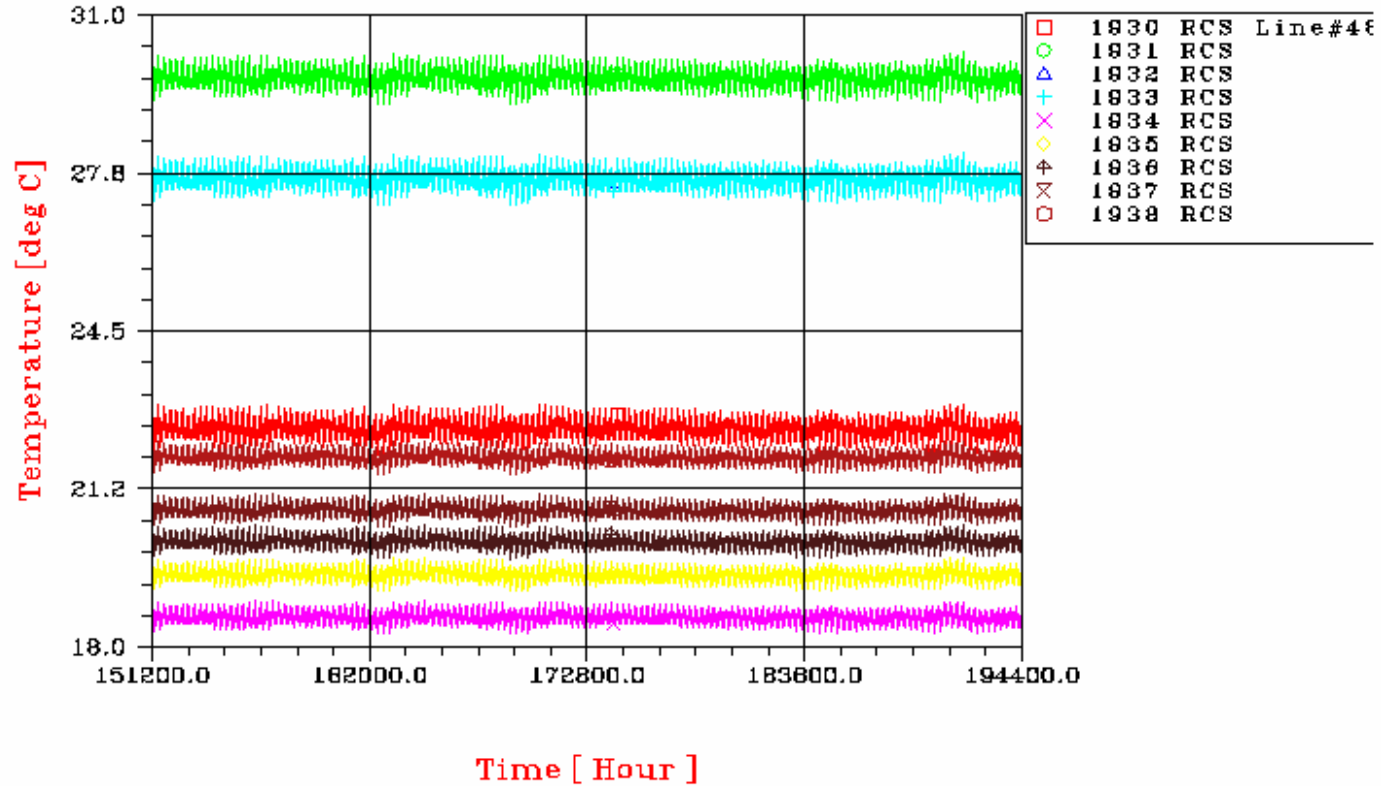

Controlled Distribution

REFERENCE : H-P-RP-AI-0040

DATE : 29/SEP/06

ISSUE : 06

Page : 404/405

PLANCK CASE C SURVIVAL

RCS line #48

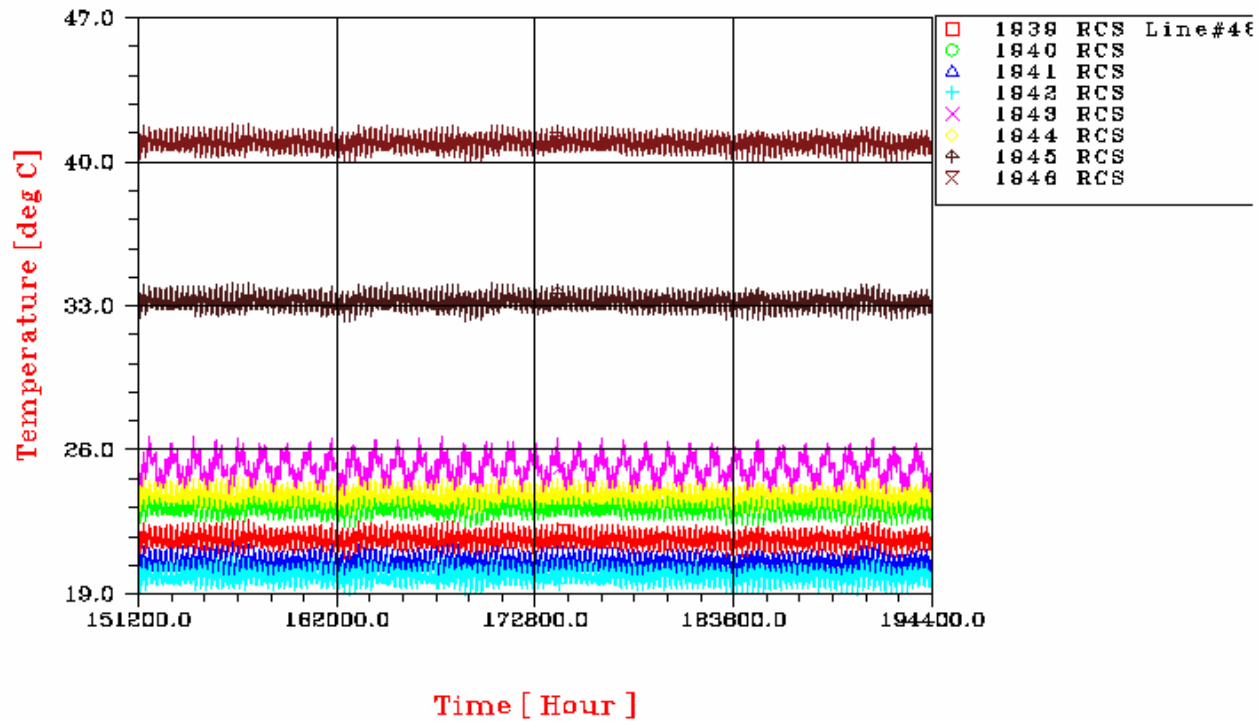

Controlled Distribution



REFERENCE : H-P-RP-AI-0040

DATE : 29/SEP/06

ISSUE : 06

Page : 405/405

END OF DOCUMENT