

HERSCHEL / PLANCK

**Design & Development Plan
DDP
H-P-1-ASPI-PL-0009
Product Code: 000000**

Rédigé par/ <i>Written by</i>	Responsabilité-Service-Société <i>Responsibility-Office -Company</i>	Date	Signature
	Herschel/Planck Team		
Vérifié par/ <i>Verified by</i>			
P. RIDEAU	System Engineer	18/11/04	<i>[Signature]</i>
D. MONTET	AIV Manager	8.11.04	<i>[Signature]</i>
Approbation/ <i>Approved</i>			
C. MASSE	Product Assurance Manager	22/11/04	<i>[Signature]</i>
J-J. JUILLET	Project Manager	22.11.04	<i>[Signature]</i>

Data management: G. SERRA

Entité Emettrice: Alcatel Space - Cannes
(détentrice de l'original):

**Design & Development Plan
(DDP)**

Doc. n° H-P-1-ASPI-PL-0009
 Issue: 4 / Revision: 1
 Date: 8/11/2004
 Page 2/155

HERSCHEL/PLANCK		DISTRIBUTION RECORD	
Design & Development Plan (DDP)		Issue 4 / Revision 1	
DOCUMENT NUMBER : H-P-1-ASPI-PL-0009		Date: 8/11/2004	
EXTERNAL DISTRIBUTION		INTERNAL DISTRIBUTION	
ESA	X	HP team	X
ASTRIUM	X		
ALENIA	X		
CONTRAVES			
TICRA			
TECNOLOGICA			
Arianespace			
		Clf Documentation	Orig.

ENREGISTREMENT DES EVOLUTIONS / CHANGE RECORDS

ISSUE	DATE	§ : DESCRIPTION DES EVOLUTIONS § : CHANGE RECORD	REDACTEUR AUTHOR
1	30/07/2001	First issue	
1/1	14/12/2001	<p>Pages 18/19 (Solar Arrays cells) ⇒ RID SVM 002</p> <p>Pages 19/20 (PLM Temperature level & stability) ⇒ RID AIV 037</p> <p>Pages 24/26 (RF pattern of the TTC antennas) ⇒ RID AIV 026</p> <p>Pages 47/48 (STM Test objectives) ⇒ RID AIV 033</p> <p>Page 64 (Power Subsystem) Page 67 (Herschel Sunshield ... & Planck Solar Array) ⇒ RID SVM 002</p> <p>Page 69 (RCS) ⇒ RID AIV 039</p> <p>Pages 88 to 91 (Software Validation) ⇒ RID AIV 041 & 042</p> <p>Pages 97 and 101 (GaAs Solar cells) ⇒ RID SVM 002</p> <p>Pages 135/136 (Verification methods) ⇒ RID AIV 053</p> <p>Pages 135 (Verification methods) ⇒ RID AIV 043</p> <p>Pages 138 and 142 (Solar cells) ⇒ RID SVM 002</p>	

**Design & Development Plan
(DDP)**

Doc. n° H-P-1-ASPI-PL-0009

Issue: 4 / Revision: 1

Date: 8/11/2004

Page 4/155

ISSUE	DATE	§ : DESCRIPTION DES EVOLUTIONS § : CHANGE RECORD	REDACTEUR AUTHOR
1/2	07/01/2002	Page 45 (Planck STM) Pages 60/61 (Planck PLM) Page 62 (Planck Telescope) Page 68 (Planck PLM Cryo-Structure) Page 82 (Planck Model Philosophy) Page 100 (Planck Reflectors) Pages 151 to 153 (Planck Verification Approach) ⇒ RID PLM 003	
2	27/06/2002	PDR Issue Table 3.5 deleted Chapter 8.3 AIT flows depicted in the relevant AIT Plans	
2/1	01/10/2002	§6.2.1 page 48 (PDR RID 8373) §6.2.4 page 58 (PDR RID 8373) §3.4 page 27 Figure 6.2.3-2 page 57 §6.3.2 page 59 §6.9 page 81	

**Design & Development Plan
(DDP)**

Doc. n° H-P-1-ASPI-PL-0009

Issue: 4 / Revision: 1

Date: 8/11/2004

Page 5/155

ISSUE	DATE	§ : DESCRIPTION DES EVOLUTIONS § : CHANGE RECORD	REDACTEUR AUTHOR
3/0	12/02/2004	<p>pre-CDR Issue Overall document: Applicability Matrix (Refer to §1) Phase B activities moved to past tense ! §2.2 Herschel Alignment Plan, ALCATEL document as reference §§3.1 & 3.2: Ariane 5 ECA §3.3.1: - LOU Optical Channel Windows - Solar Array cells using triple junction GaAs technology §3.3.2: Thermal links between PPLM and SVM: introduction of the SVM dummy and the three batches delivery - Heat Pipes: condition using §3.3.2 μ-vibration: introduction of measurement campaigns §3.3.3.1: Herschel Optical performances: Optional test during TV/TB test §§3.3.3.1 & 3.3.3.2: RF Pattern of only LGA antennas Figure 4.7: updated Table 5.1 (Herschel): updated Table 5.2 (Planck): updated Table 5.3 (AVM): added Figures 6.1: updated §6.2.1 (STM) & Table 6.2.4: Overall updating to reflect the present approach with all thermal tests on STM performed at Module levels §6.2.2 and Figure 6.2.3-1: SVT-0 on AVM and no longer on SVM before delivery §6.2.3: Typo corrected (instruments were missing !) Table 6.2.4 updated §6.31: TV/TB on both SVM STM §6.3.2 (PPLM): reference to Annex 10 deleted and only mechanical testing performed at Satellite level</p>	

**Design & Development Plan
(DDP)**

Doc. n° H-P-1-ASPI-PL-0009

Issue: 4 / Revision: 1

Date: 8/11/2004

Page 6/155

ISSUE	DATE	§ : DESCRIPTION DES EVOLUTIONS § : CHANGE RECORD	REDACTEUR AUTHOR
3/0	12/02/2004	<p>§6.4.1 (& Table 6.9-1) H-Tel models for H-Sat STM</p> <p>§6.4.2 (P Telescope): reference to Annex 10 deleted</p> <p>§6.5.2 SVM Structure: no need of P-SVM STM structure for PPLM CQM testing and only FM instrument panels to be delivered in advance</p> <p>§6.5.2 Planck Solar Array: three different types of panels instead of two to be tested</p> <p>§6.5.2 Flight Model of Planck Solar Array and HSS submitted to an acoustic test at acceptance level.</p> <p>Table 6.7-1: Herschel instruments for AVM</p> <p>Table 6.7-2: no LFI instruments for Planck CQM/STN</p> <p>Table 6.9-2: Typo, Planck Solar Array added</p> <p>§6.10.5: RF Suitcase design</p> <p>§6.11.2 SVF : no need to run two or more S/W in parallel and no H/W in the loop</p> <p>§7.2.4: Typo, mechanical qualification on STM, not on CQM</p> <p>§7.2.6.3 SCC CQM replaced by a STM</p> <p>§7.2.7 Planck Reflectors: reference to Annex 10 deleted</p> <p>§7.2.8 SVM: P-SVM STM structure replaced by a dummy for PPLM CQM testing</p> <p>§8.1 HPSDB validation moved to this chapter (was in §8.5.3)</p> <p>§8.2: Typo, ESTEC replaced by ETS</p> <p>§§8.3 to 8.7: overall update reflecting the present philosophy</p> <p>Table 9.4.6.1-1b: RCS tanks moved to cat. C</p> <p>Table 9.4.6.1-2 updated according doc H-P-2-ASED-LI-0012</p> <p>Annex 10: deleted</p>	

**Design & Development Plan
(DDP)**

Doc. n° H-P-1-ASPI-PL-0009

Issue: 4 / Revision: 1

Date: 8/11/2004

Page 7/155

ISSUE	DATE	§ : DESCRIPTION DES EVOLUTIONS § : CHANGE RECORD	REDACTEUR AUTHOR
4/0	19/07/04	<p><u>CDR System Issue</u></p> <p>§2.2: new reference for Risk Analysis document</p> <p>§6.2.1 Planck PLM CQM built Standard: Verification of the active cooling chain added as main objective</p> <p>§6.2.1 Sine and Acoustic Testing: Early acoustic testing on PPLM CQM is baseline</p> <p>§6.2.3 & Table 6.2.3-2: EMC testing CS is only performed at lower levels</p> <p>§6.2.4 Test Matrix – Summary SVM and PLM levels added</p> <p>Table 6.9-2: H/W Matrix for PPLM CQM updated</p> <p>§7.2.6 Update of critical areas for instruments</p> <p>§§7.2.8 & 7.2.9 Avionics Consolidation Plan</p> <p>§8.3.1: Micro-vibration characterisation and COG and Mol determination in dry configuration were missing</p> <p>§8.3.2: Micro-vibration characterisation was missing</p> <p>§9.5: Acronyms to be used in the VCD according H-P-ASPI-LT-2096 dated 04/11/02</p> <p><u>Planck STM removal</u></p> <p>§3.3.2, §4.4, Figure 4.7, Figure 6.1-2, §6.2.1, Figures 6.2.1 & 6.2.3-1, §6.2.4 and associated tables, §6.3.1, §6.5.2; Tables 6.6.6 & 6.7-2 §7.2.4, §7.2.8 Table 8.2, §8.3.3, §8.3.4, §8.5</p> <p><u>Planck Telescope FM & Reflectors</u></p> <p>§3.3.3.2, §6.4.2, §7.2.7, §10</p>	<p>RID CDR PPLM PAIV n° 10918</p> <p>RID CDR HPLM HAIV n° 11316</p> <p>RID CDR PLMs PAIV n° 10973 PAIV n° 10918 HAIV n° 11377</p> <p>RID CDR PPLM PAIV n° 10973</p>

**Design & Development Plan
(DDP)**

Doc. n° H-P-1-ASPI-PL-0009

Issue: 4 / Revision: 1

Date: 8/11/2004

Page 8/155

ISSUE	DATE	§ : DESCRIPTION DES EVOLUTIONS § : CHANGE RECORD	REDACTEUR AUTHOR
4/1	8/11/04	<p><u>Clamp-band release on Planck PFM</u> §6.2.1 Shock Environment Qualification Table 6.2.4-1</p> <p><u>Update as per CDR status and findings with results from schedule consolidation exercise</u></p> <p>- Document: "No Planck STM – Risk analysis status" added as Reference document [RD8]: §1. Introduction §2.2 Reference Documents §3.3.2 Risks Analysis for Planck §6.2.1 STM test objectives §6.2.1 Planck STM Built Standard - Static test on a dedicated cone of SVM primary structure: Table 6.2.4-2 §6.5.2 SVM Structure - Chapter 4.1 to 4.4 Deleted (limited to previous conclusion) - Launch date §1. Introduction: Tentative date = August 07 - Herschel FM instead of PFM Overall document and in particular §6.2.3 - RFQM testing in ALCATEL premises Table 8.2 - Mechanical & Electrical Fit-check on Herschel FM § 8.3.2 Herschel PFM AIT Flow - Equipment Classification Tables 9.5.6.1</p>	<p>RID MTP-033</p> <p>RID DAIV-1119</p>

TABLE OF CONTENTS

1	INTRODUCTION	12
2	APPLICABLE AND REFERENCE DOCUMENTS	16
2.1	APPLICABLE DOCUMENTS	16
2.2	REFERENCE DOCUMENTS	18
3	ESSENTIAL REQUIREMENTS	19
3.1	MISSION REQUIREMENTS	19
3.2	EXTERNAL CONSTRAINTS	21
3.3	RISK ASSESSMENT	22
3.3.1	<i>Risk analysis for Herschel</i>	22
3.3.2	<i>Risks analysis for Planck</i>	24
3.3.3	<i>System performances not verifiable by a global or End to End test</i>	29
3.4	TECHNICAL HERITAGE	33
3.5	HERSCHEL/PLANCK COMMONALITY	35
3.6	MODULAR CONCEPT	36
3.7	CONTAMINATION	36
4	MODEL PHILOSOPHY DEFINITION	39
5	AIT/AIV ORGANIZATION	42
6	MODEL PHILOSOPHY AND DEVELOPMENT	46
6.1	INTRODUCTION	46
6.2	SYSTEM DEVELOPMENT MODELS	48
6.2.1	<i>Structural & Thermal Model</i>	48
6.2.2	<i>AVionics Model (AVM)</i>	57
6.2.3	<i>Proto-Flight Model (PFM)</i>	61
6.2.4	<i>Test Matrix - Summary</i>	64
6.3	MODULE DEVELOPMENT MODELS	67
6.3.1	<i>SVM development models</i>	67
6.3.2	<i>PLM development models</i>	67
6.4	TELESCOPE DEVELOPMENT MODELS	69
6.4.1	<i>Herschel Telescope</i>	69
6.4.2	<i>Planck Telescope</i>	70
6.5	SUBSYSTEM DEVELOPMENT MODELS	71
6.5.1	<i>Electrical Subsystems</i>	71
6.5.2	<i>Mechanical Subsystems</i>	73

**Design & Development Plan
(DDP)**

Doc. n° H-P-1-ASPI-PL-0009

Issue: 4 / Revision: 1

Date: 8/11/2004

Page 10/155

6.6	UNITS DEVELOPMENT MODELS	78
6.6.1	Units Model Classification and Model philosophy	78
6.6.2	Existing and already qualified units (Category A)	79
6.6.3	Existing but not completely qualified units (Category B)	80
6.6.4	Existing units requiring minor modifications (Category C)	80
6.6.5	Units of new design (Category D)	80
6.6.6	Units – Model philosophy	81
6.7	MODEL PHILOSOPHY FOR SCIENTIFIC INSTRUMENTS	81
6.8	SPARE PHILOSOPHY	85
6.9	MODEL PHILOSOPHY SUMMARY TABLES	87
6.10	GROUND SUPPORT EQUIPMENT (GSE)	89
6.10.1	Mechanical Ground Support Equipment (MGSE)	89
6.10.2	Electrical Ground Support Equipment (EGSE)	89
6.10.3	Optical Ground Support Equipment (OGSE)	90
6.10.4	Cryo Vacuum Support Equipment (CVSE)	91
6.10.5	RF Suitcase	91
6.11	ON BOARD SOFTWARE (OBS) DEVELOPMENT	92
6.11.1	Introduction	92
6.11.2	Software Validation Facility (SVF)	93
6.11.3	Software Validation	94
6.11.4	Independent Software Validation (ISV)	96
7	DESIGN AND DEVELOPMENT FLOW	98
7.1	SYSTEM REVIEWS – DEFINITION	98
7.2	CRITICAL AREAS AND DEVELOPMENT MILESTONES	101
7.2.1	Introduction	101
7.2.2	Planck PLM	102
7.2.3	Herschel E-PLM	103
7.2.4	Planck spacecraft	104
7.2.5	Herschel spacecraft	104
7.2.6	Instruments	105
7.2.7	Planck Reflectors	106
7.2.8	SVM	107
7.2.9	SVM Subsystems	107
8	ASSEMBLY, INTEGRATION AND TESTS FLOW	108
8.1	GENERAL AIT FLOW	108
8.2	TEST FACILITIES	110
8.3	SATELLITE AIT FLOW	112
8.3.1	Herschel STM AIT flow	112
8.3.2	Herschel PFM AIT flow	113
8.3.3	Planck PLM CQM/RFQM AIT flow	114
8.3.4	Planck PFM AIT flow	115

**Design & Development Plan
(DDP)**

Doc. n° H-P-1-ASPI-PL-0009

Issue: 4 / Revision: 1

Date: 8/11/2004

Page 11/155

8.4	AVM AIT FLOW	116
8.5	SVM AIT FLOW	118
8.5.1	Herschel SVM STM AIT flow	118
8.5.2	SVM FM AIT flow	119
8.6	H-EPLM AIT FLOW	121
8.6.1	Herschel PLM EQM AIT flow	121
8.6.2	Herschel E-PLM PFM AIT FLOW	123
8.7	PLANCK PLM AIT FLOW	126
9	VERIFICATION PLAN	128
9.1	OVERALL LOGIC	128
9.2	RESPONSIBILITIES	129
9.3	VERIFICATION PROGRAMME PHASING	130
9.4	ENGINEERING DATA BASE	131
9.5	VERIFICATION PROGRAMME/CONTROL PLAN (VPP/VCP)	132
9.5.1	Verification objectives	133
9.5.2	Verification concept	135
9.5.3	Verification approach	135
9.5.4	Verification types	137
9.5.5	Verification methods	139
9.5.6	Verification levels	140
9.5.7	Verification Matrixes	149
9.5.8	Test Requirement Sheets	151
9.5.9	Analysis Requirement Sheets	152
9.6	VERIFICATION CONTROL DOCUMENT (VCD)	153
10	ANNEX PLANCK TELESCOPE FM VERIFICATION APPROACH	155

1 INTRODUCTION

- IMPORTANT NOTICE - IMPORTANT NOTICE - IMPORTANT NOTICE -

This Herschel/Planck Design & Development Plan (DDP) proposes a basic development and testing philosophy at the time of the System CDR. It insures a consistent approach to requirements verification and qualification of the satellites, modules, subsystems and units providing a high level of confidence on achievement of the scientific mission objectives.

All deviations regarding previous approach, mainly the change of the model philosophy with the deletion of the Planck Satellite STM for programmatic reason to re-establish a credible baseline schedule, are addressed in document [RD8] with associated analysis of induced risks and their mitigation.

As it is the sole document to cover the design & development of the satellites, modules, subsystems and units, all chapters and/or paragraphs are introduced by the acronyms:

[H/P]

when the content addresses and concerns the overall Herschel/Planck program,

[H-Sat] or [P-Sat]

when the content is dedicated to design & development of respectively only Herschel Satellite or Planck Satellite,

[H-SVM] & [P-SVM],

when the content is dedicated to design & development of the Herschel SVM and Planck SVM as well as their subsystems and units,

[H-EPLM],

when the content is dedicated to design & development of the Herschel Extended Payload Module as well as its subsystems and units,

[P-PLM],

when the content is dedicated to design & development of the Planck Payload Module as well as its subsystems and units.

**Design & Development Plan
(DDP)**

Doc. n° H-P-1-ASPI-PL-0009
Issue: 4 / Revision: 1
Date: 8/11/2004
Page 13/155

After consolidation and further refinement in Phase B and beginning of Phase C, it is the basis to issue the Verification Programme Plan (VPP) (refer to chapter 9) as illustrated by Figure 1.

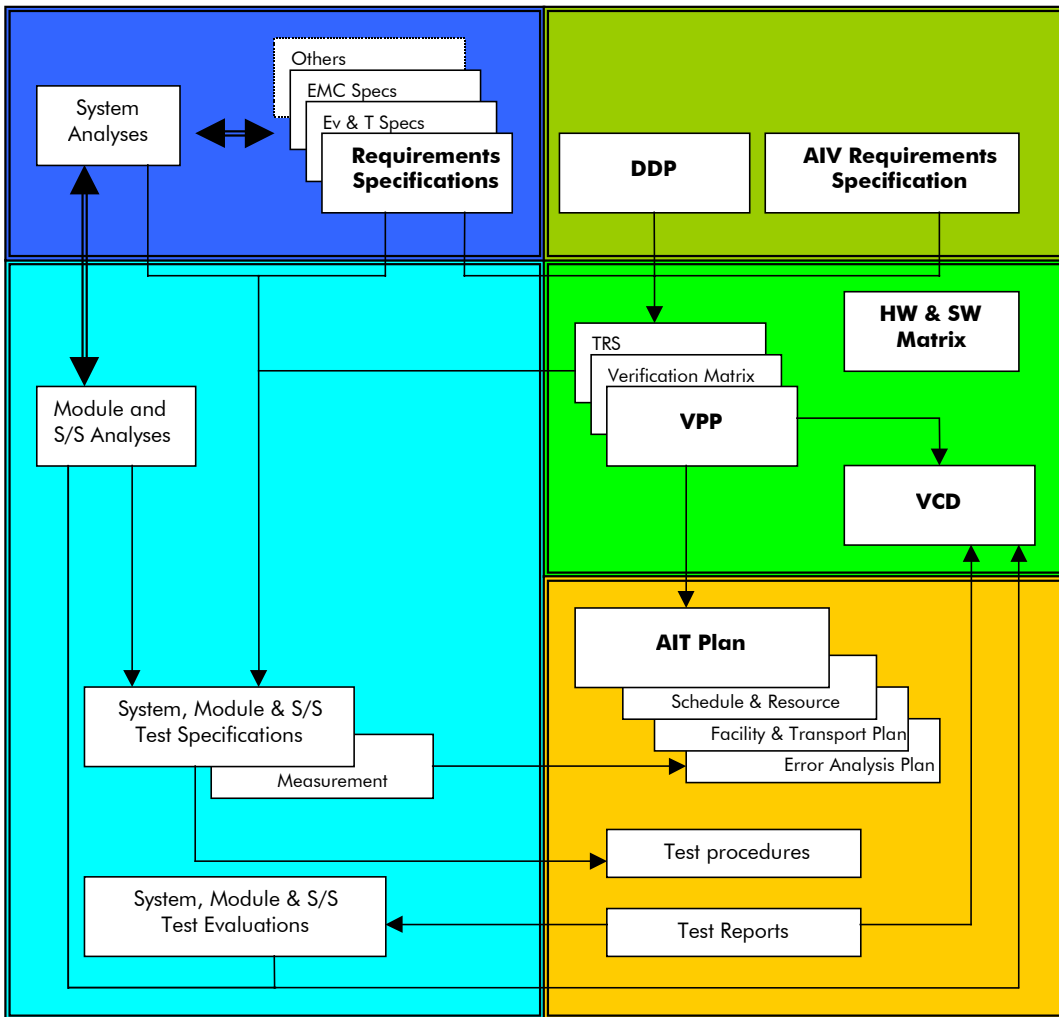

Figure 1. Verification logic and links

Design & Development Plan (DDP)

Doc. n° H-P-1-ASPI-PL-0009

Issue: 4 / Revision: 1

Date: 8/11/2004

Page 14/155

It consequently defines the models necessary at each level to achieve the mission objectives, the verification needs and the delivery of required hardware/software.

The DDP is built considering the following guidelines and constraints:

- to meet the specificity of the two payloads, in particular the severe cryogenic constraints of the various instruments
- to prevent Herschel and Planck Payloads including the FPU's from molecular and particulate contamination risks
- to provide flexibility for the instrument development, assembly, testing and calibration
- to achieve the design, manufacturing, assembly and testing of the two payloads and satellites in order to be launched together with the same flight in 2007: tentative date is August.

To meet these requirements the DPP is based on:

- maximum use of existing expertise, experience and heritage in order to introduce the concept of verification in the design
- modular concept (Telescope Assembly, PLMs and SVMs) with simple and limited interfaces allowing as far as possible separate design, development and test of each module
- Herschel concept and testing inherited from ISO. The use of the ISO experience, analysis and test results, as well as both on-board or GSE hardware has been permanently considered
- safe and reliable designs which rely on simple and proven concepts or technologies, supported by extensive and early analysis, simulations and trade-offs
- maximum use of flight proven equipment units for the service modules

**Design & Development Plan
(DDP)**

Doc. n° H-P-1-ASPI-PL-0009

Issue: 4 / Revision: 1

Date: 8/11/2004

Page 15/155

- design of Herschel and Planck SVMs as similar as possible (at least by using the same architecture and technology) allowing minimum development, common procurement, common spares and common qualification and development tests.
- strong test programme allowing early verification and qualification at equipment, subsystem and module levels for early resolution of potential problems with appropriate schedule contingency
- independent software validation and early functional interface tests
- minimum number of models with maximum reasonable re-utilisation
- early definition and selection of existing test facilities with regard to the specific mission requirements (cryogenic and RF tests)
- cleanliness plan based on a design offering as far as possible cleaning possibilities and on a maximum use of protective covers
- maximum communality and use of the ground support equipment including during the launch campaign
- tight co-operation with the experimenters: integrated teams for design interfaces in Phase B, integration and testing all along Phase C/D.

2 APPLICABLE AND REFERENCE DOCUMENTS

[H/P]

2.1 APPLICABLE DOCUMENTS

AD1-1	Herschel/Planck System Requirement Specification (SRS) Document no. SCI-PT-RS-05991
AD1-2	Herschel/Planck System AIV Requirement Specification Document no. SCI-PT-RS-07430
AD1-3	Herschel/Planck Product Assurance Requirements Document no. SCI-PT-RS-04683
AD1-10	Instrument Interface Document, Part A (IID-A) Document no. SCI-PT-IID-A-04624

AD2-1	ARIANE 5 User's Manual Issue 03 Rev. 00 Date: Mar 2000
-------	--

**Design & Development Plan
(DDP)**

Doc. n° H-P-1-ASPI-PL-0009

Issue: 4 / Revision: 1

Date: 8/11/2004

Page 17/155

AD3-5	Cleanliness Requirements Specification Document no. H-P-1-ASPI-SP-0035
AD3-14	Environment & Test Requirements Specification Document no. H-P-1-ASPI-SP-0030
AD3-19	EMC/ESD Control Plan Document no. H-P-1-ASPI-PL-0038
AD3-20	EMC Requirements Specification Document no. H-P-1-ASPI-SP-0037
AD3-25	Technical description of RF test proposed in the ALCATEL Compact Antenna Test Range Document no. H-P-3-ASPI-TD-0054
AD3-45	Specification of Facilities for Planck Cryogenic Test Sequence Document no. H-P-3-ASPI-TS-0051

2.2 REFERENCE DOCUMENTS

RD1	Risk Analysis Critical Items List and Control Plan Document no. H-P-1-ASPI-LI-0212
RD2	Lessons learnt – Strategy Plan Document no. H-P-2-ASED-PL-0006
RD3	Herschel TB/TV Test Trade-off Qualification Test Phase Document no. H-P-2-ASED-TN-0036
RD4	Deleted
RD5	Herschel Alignment Plan Document no H-P-1-ASPI-PL-0276
RD6	Planck Alignment Plan Document no H-P-3-ASPI-PL-0078
RD7	Reflectors and Telescope FM Optical Verification status Document no H-P-3-ASP-RP-0817
RD8	No Planck STM – Risk Analysis Status Document no H-P-1-ASP-TN-0837

3 ESSENTIAL REQUIREMENTS

3.1 MISSION REQUIREMENTS

[H/P]

In terms of Design and Development, the Herschel/Planck programme consists in two satellites with independent missions but launched together on the same ARIANE 5 ECA.

The chosen dual launch configuration allows performing the development of each satellite independently. However, the commonality of the two SVM authorises important rationalisation of the test sequence and of Ground Support Equipment (GSE).

For Herschel and Planck satellites, the number and the intricacy of the on board instruments working at cryogenic temperature contribute to the complexity of the development. Consequently the verification flow shall be sufficiently flexible to adapt to potential problems with minimum impact on the final delivery date.

In most of cases, because of the need of cryogenic environment, end to end performance tests of the scientific payloads will not be possible at system level. The verification plan shall take into account such a constraint in order to insure that the performances are verified as totally as possible at other levels and that nothing can degrade these performances at system level.

The cryogenic temperatures required for the two missions are very constraining in terms of cost and schedule for the on ground tests. The development approach is built with emphasis on rationalisation and simplification of cryogenic tests at each level (from equipment to system), without affecting the confidence in the performance of the system.

Consequently:

- the schedule is made flexible by means of:
 - margins to integrate the technical risks
 - contingency period at the end of system AIT sequence.

**Design & Development Plan
(DDP)**

Doc. n° H-P-1-ASPI-PL-0009

Issue: 4 / Revision: 1

Date: 8/11/2004

Page 20/155

- The validation sequences of the Satellites have to be reinforced by:
 - advanced validation of design by using other models than the Flight Models themselves
 - advanced validation of AIT tools (EGSE, test procedures, test sequences...).
- The qualification is achieved as early as possible by means of:
 - specific qualification or pre-qualification models
 - flexibility in the model philosophy such that it induces a high level of reactivity.
- The long duration of the development phase of the experiments is compensated by an adequate development plan at each level allowing overlapping of their development with the Satellites' one.
- The modular concept of the two satellites allows separate testing and flexibility in the overall AIT sequence.

3.2 EXTERNAL CONSTRAINTS

[H/P]

The following constraints imposed by the Agency have been taken into account:

- a.** The model philosophy of instruments and associated EGSE to be delivered.
=> overall model philosophy
- b.** The model philosophy of Herschel telescope and Planck reflectors (ESA furnished equipment: EFE) to be delivered.
=> overall model philosophy
- c.** The request to return CQM instruments and QM Planck reflectors at the end of utilisation for system test.
=> development and overall schedule.
- d.** The ESA requirement for flight spares of all units of the Herschel and Planck SVM.
=> model philosophy of SVM units
- e.** The use of Agency specified launch vehicle: ARIANE 5 ECA.
=> environmental test sequence.
- f.** The imposition by the Agency of major milestones in the programme (kick-off, instruments and EFE delivery, spacecraft delivery, launch date).
=> development and overall schedule.
- g.** The ESA requirement for a radio frequency model of Planck.
=> model philosophy of Planck

3.3 RISK ASSESSMENT

[H/P]

In the frame of the Phase B, a technical risk analysis has been initiated at Satellite and Module levels in order to put the right effort of development on the right points. The results and the action plan are provided in document [RD1].

This document will define a risk reduction action plan for each critical item identified. It will clearly identify the milestones (in term of events and dates) to be followed in the schedule. Success or acceptance criteria shall also be identified (such as review completion, activity completion, H/W or S/W installation, ...) to allow a detailed follow-up and formal closure for each action.

[RD1] complete this paragraph as well as paragraph 7.2.

From the present definition, the following technical risks and consequently pre-development and/or advanced analyses are identified.

3.3.1 Risk analysis for Herschel

- ACMS

[H-SVM]

The main risk identified is the schedule impact due to its development duration. In order to secure the schedule, in Phase B, an important effort of the Core Team has been devoted to issue a detailed design and complete and coherent requirement specifications down to ACC as inputs for the ITT of this subsystem. It will required, as part of the ACMS ITT, that first issues of Equipment Requirements Specifications will be included in the proposal.

This effort will also cover the verification aspect; the requirement verification method and tools will be specified.

- E-PLM Cryostat

[H-EPLM]

The E-PLM cryostat is based on the re-use of ISO technology. Apart following points, no area has been identified as critical for the mission.

LOU Optical Channel Windows

A pre-qualification phase is implemented:

- to determine the characteristics of such windows in term of optical properties
- to qualify them regarding the space (mechanical & thermal) environment

The safety aspect will be addressed in this phase.

LHe Valves

Astrum recommends an improvement of the ISO LHe valves; thus a pre-qualification in phase B has been done and the MAIT of the Liquid Helium Valves have to be started in the advanced Phase C/D.

He II tanks

Based on ISO experience, the main risk is the tightness. The tank material procurement has been part of the first ITT batch at the beginning of Phase B in order to prepare the tank manufacturing in early phase. Two tanks will be manufactured in parallel, in case of problem on the first one, the turning over of the second one in flight model can be done in two months without impacting the overall schedule thanks to time reserves presented in the schedule report.

Cryogenic Harness

The early start of MAIT activities for this critical and non-usual equipment is a prerequisite for the completion of the program in the given time limits. The PFM Cryogenic Harness will be installed for the mechanical and thermal test campaign on Herschel STM.

– CDMS

[H-SVM]

The main risk identified for the CDMS is the 48 hour-autonomy implying the storage of the mission timeline on-board for 48 hours. As for the ACMS, the Core Team will issue a complete CDMS and CDMS SW requirement taking into account these aspects for the on board Timeline Memory and Mass Memory sizing via suitable margins allocations, and FDIR design.

As far as FDIR is concerned, a dedicated software simulation, based on a specific tool (UML), of the selected implementation has been carried out as early as in phase B, thus permitting an advanced and exhaustive validation of the FDIR cases.

- Solar Arrays cells

[H-EPLM] & [P-SVM]

The procurement of the Planck Solar Array and of the Herschel Sunshield will be co-ordinated. The Planck Solar Array and the Herschel Sunshield is based on cells using triple junction GaAs technology. The choice of different solar cells for Planck and Herschel cost and risk assessment has naturally lead to selection of a single cell supplier.

Analysing differences in design with cells already qualified or under qualification, the relevant sub-contractor will issue a specific Design & Development Plan for Solar Cells. This plan will reflect the complementary or full qualification tests to be performed to take into account the Planck Solar Array and Herschel Sunshield environment and designs.

Results should be available for the CDR.

The other SVM subsystems such as structure, RCS, power and telecommunication are not critical. These subsystems will, as far as possible be able to profit from their heritage of previous programmes and will use exclusively proven design, material and technologies, so no pre-development is necessary in this area.

3.3.2 Risks analysis for Planck

- Planck PLM (PPLM) temperature level and stability

[P-PLM]

The thermal performances of the passive stage of the PPLM are one of the main challenges of the design and development of Planck. These performances will be verified at an early stage in the program thanks to the specific cryogenic test to be performed on the PLM CQM of Planck.

The cooling of the PPLM and the need to reach a temperature of 0.1 K for HFI detectors is a key for the success of the Planck mission. The thermal design to reach this functional temperature is obviously sensitive to the thermo-optical parameters of the coating.

In order to consolidate the design of the thermal control and to reduce uncertainties of analytical predictions the following programme is performed:

Design & Development Plan (DDP)

Doc. n° H-P-1-ASPI-PL-0009

Issue: 4 / Revision: 1

Date: 8/11/2004

Page 25/155

- measurement campaign of thermo-optical characteristics of emissive coatings at low temperature. This campaign will help to select the coating of the main radiator (external side of the telescope baffle and topside of groove 3), and to reduce uncertainties in the thermal performance prediction. The emissivity of potential candidate coatings is presently being measured on samples and at cold temperature,
- measurement campaign of thermal conductivity characteristics of the grooves face-sheets,
- to reach the emissivity performance of 0.9 at 50K, an optimisation of the geometrical pattern of the emissive surface associated to the coating efficiency must be done. Samples will be manufactured in order to qualify the manufacturing processes and to measure the performances of the emissive surface.

The improved knowledge of these sensitive parameters (emissivity and thermal conductance) associated to an optimisation of the geometrical pattern will allow assessing by analysis (with relevant uncertainties) the thermal performances of the passive stage of the PPLM prior to the cryogenic test where they will be verified and confirmed.

Additional information regarding these parameters will be obtained through the thermal test to be performed on the Cryo-structure and baffle.

The alternative to build a scaled down model of the PPLM is not retained due to the main drawback of the implied scale factor leading to increasing the uncertainty factors on the results of the analysis. The other drawback is that this scaled model shall be done in parallel to the PPLM CQM sequence to be representative and consequently will not secure the schedule by managing two models at the same time.

- Thermal links between PPLM and SVM

[P-PLM] & [P-SVM]

The strong thermal links between PPLM and SVM due to instrument design induce to perform PLM thermal and cryogenic tests with a SVM. This is solved:

- for the PPLM CQM testing by replacing the SVM STM by a dummy,
- for the FM Satellite by the availability of the Planck SVM FM in due time with time reserves in the schedule by a delivery after subsystems SIT and then combined IST at Satellite level (refer to § 8.5.2).

- Straylight reduction

[P-PLM]

The straylight rejection is the key parameter of the Planck mission performance. The design optimisation and the performance prediction requires accurate computation then measurement of the far field and near field radiated patterns over all the space for attenuation factors between 65 and 98 dB.

On one hand, the existing RF or optical software are not optimised for such an application and shall be used with care because they are not exact solvers and lot of simplifications is needed to meet reasonable computation time.

On another hand existing facilities do not cover individually all the requirements for RF testing of Planck and there is a lack of experience for such accurate measurements in a large spectral band and for a very large angular space.

The Radio Frequency Measurements planned on the Radio Frequency Qualification Model are planned as early as possible in phase C, when the QM telescope equipped with QM reflectors becomes available. Taking into account the criticality of the straylight for the mission, this RFQM test is judged too late to allow design modification and mainly test facility adaptation. So a development programme was done in phase B with the objective to validate very early both computation and measurement methods in the domain of application of Planck.

The principle of this validation is to compare model results with measurements on the existing reflectors from ARCHEOPS instrument. The output of such a validation will be:

- verification of software performance through

- accuracy of the model
- limits of the model
- limits of the model
- authorised/non-authorised simplifications for the modelisation
- demonstration of measurement feasibility
- validation of the facility and/or definition of necessary improvements.

The model used for this validation is called Radio Frequency Development Model (RFDM). It is made of ARCHEOPS reflectors mounted on a dedicated structure made together with a baffle dummy shape identical to Planck one. It is not fully representative of the Planck geometry but this is not mandatory with the here above objectives.

- PPLM integration

[P-PLM]

This risk has already been identified in the previous studies. The integration mock-up developed by ALCATEL in 1999 was aimed at analysing this aspect. It has induced improvements reflected in the present design of the PPLM. This constraint has been taken into account in the trade-offs performed in particular regarding the groove angle.

- Micro-vibration perturbations for the dilution cooler in flight and during on ground tests.

[P-PLM]

This point and the relevant solutions are well known in ALCATEL from previous satellite projects. Specific analysis and measurement campaigns will be performed to consolidate the relevant solutions applicable to Planck objectives.

- CDMS

[P-SVM]

Refer to Herschel in § 3.3.1.

- Thermal Control (Heat pipes)

[P-SVM]

The heat pipes of the sorption cooler radiator will be used with a high power density varying with time. So a complement of qualification is performed for this item.

- ACMS for spun satellite

[P-SVM]

The main risks are the nutation monitoring/control, the attitude control during delta-V manoeuvres and the wobble impact. Based on Meteosat and MSG programmes and in the frame of the Avionics effort of the Core Team in Phase B, these aspects will be taken into account. Detailed design and complete/coherent requirement specifications down to equipment level will be issued. The wobble budget will be established and maintained up to date by the Prime Contractor.

- No Planck STM

[P-Sat] & [P-SVM]

Refer to [RD8]

3.3.3 System performances not verifiable by a global or End to End test.

[H/P]

According recommendation of the "ISO Lessons learnt", this paragraph presents the risk analysis on main system performances not verifiable by a global or End to End test. These main system performances are the following:

Herschel	Planck
Herschel optical performances	Planck optical/RF performances
Herschel instruments alignment	Planck external straylight (telescope RF diagram)
Herschel straylight	Planck internal straylight (telescope RF diagram & temperature fluctuations)
RF pattern of the TTC antennas	RF pattern of the TTC antennas

For each performance, the level where the verification is done and the used method are described. This approach aims to minimise the risks and to evaluate with a high accuracy the final performances of Herschel and Planck Satellites.

This approach will be supported by Analysis Requirement Sheet (ARS) covering also other specific performances not verifiable by global testing and to be listed in the Verification Program Plan (VPP).

3.3.3.1 Herschel

Optical performances

[H-EPLM]

Verification level / method

Verification done in parts of the telescope in cold condition.

Alignment of the telescope with the cryostat (see next item)

Control of the alignment stability of telescope mirrors by analysis at system level.

More direct control (to be confirmed) at Satellite level during TV/TB test in co-operation with a special alignment camera (HACS) or the "video-grametry" method.

Risks assessments

Same philosophy as the one used on ISO.

The risk is reported on the quality of alignments at instrument and spacecraft levels.

(See next item)

Instruments alignment

[H-EPLM]

Verification level / method (Refer to [RD5])

Performed in several steps by theodolite measurements:

- alignment of instruments w.r.t. the optical bench (ambient).
- alignment of optical bench w.r.t. the cryostat vacuum vessel (ambient and cryostat cooled)
- alignment of the telescope w.r.t. the cryostat vacuum vessel (ambient).
- Misalignment in thermal vacuum verified by analysis.

A more direct control is possible through the HIFI-LOU alignment windows (HIFI-FPU w.r.t. CVV or telescope)

Telescope verified separately in cold conditions

Risks assessments

Acceptable due to low sensitivity of the optical performance to dimension change

Straylight

[H-EPLM]

Verification level / method

Verified by analysis through a complete ASAP model from instrument to the telescope including cryostat, baffles and interface structures.

Risks assessments

Classical philosophy as used on ISO

RF pattern of the TTC antennas

[H-SVM]

Verification level / method

Verified on RF mock-up fully representative of the satellite including the PLM and all appendages impacting the radiation patterns and performances of the LGA antennas. The antennas will be also fully flight representative.

Risks assessments

Acceptable due to the good representativeness of the mock-up.

3.3.3.2 Planck

Optical/RF performances [P-PLM]

Verification level / method (refer to [RD6])

Performed in several steps:

- Telescope “optical measurement” verified separately in cold conditions
- Alignment of FPU's w.r.t. telescope controlled with theodolite at system level
- Verification at ambient on the RFQM, with FPU mock-up equipped with representative horns.

End to end test performed at ambient with LFI 30 GHz at Planck PFM level.

Risks assessments

Acceptable due to low sensitivity of the optical/RF performances to dimension change

Planck external straylight (telescope RF diagram) [P-PLM]

Verification level / method

Very early validation of computation process by measurement on a similar telescope (ARCHEOPS) equipped with a baffle fully representative of the Planck one on the RFDM (refer to AD3-25).

Measurements of telescope diagram performed on the RFQM from 30 GHz up to 500 GHz (TBC pending test facility performances).

Risks assessments

Acceptable due to:

- Design margins versus planet effects.
- Good representativeness of the RFQM and low sensitivity of the far outside lobes to the alignment and deformations

**Planck internal straylight
(telescope RF diagram & temperature fluctuations)
[P-PLM]**

Verification level / method

Validation of the RF model by far field measurements.

Cross check of two computation methods:

- direct computation of surface coupling in Multi GTD mode of GRASP8
- computation of the near field radiated pattern from the far field radiation pattern

Validation of the thermal mathematical model by specific transient tests during the PPLM CQM thermal and cryogenic test.

Risks assessments

Acceptable due to the margin of one order of magnitude shown by analysis.

**RF pattern of the TTC antennas
[P-SVM]**

Verification level / method

Verified on RF mock-up fully representative of the satellite including the PLM and all appendages impacting the radiation patterns and performances of the LGA antennas. The antennas will be also fully flight representative.

Risks assessments

Acceptable due to the good representativeness of the mock-up.

3.4 TECHNICAL HERITAGE

ISO heritage [H-EPLM]

At the end of the ISO programme several lessons learnt in the form of recommendations for future programmes have been issued. It is particularly relevant to review them in the frame of the Herschel/Planck programme due to the technical and overall organisation similarities between the two programmes.

Thanks to the ISO experience, precautions have been already implemented in the Herschel/Planck design and development plan by ALCATEL and its core team to minimise the development risks in areas where the ISO development suffered from being the first development of an infra red space observatory.

For example the baseline for Herschel E-PLM is to reuse as far as possible existing design(s) and hardware from the ISO development. Consequently:

- the development of the Herschel cryostat can be limited to a proto-flight model
- a full qualification will be limited to cryostat units requiring a new design for Herschel. The other units that can be used directly or with only small modifications compared to ISO design will be acceptance tested only.

The ISO heritage gives also a good confidence in the AIT procedures (including SVM/PLM mating) as well as launch procedures regarding activities relative to the cryostat.

The optical and alignment philosophy can be inspired by the one successfully applied on ISO in addition to the contamination plan already mentioned in the risk analysis.

The ISO-QM cryostat is available to be used after modification for EMC C and RS (with external source) testing of the Herschel scientific payload at operating temperature.

But as part of the risk analysis presented here below, a strategy plan to take into account the lessons learnt has been issued (refer to [RD2]).

Design & Development Plan (DDP)

Doc. n° H-P-1-ASPI-PL-0009

Issue: 4 / Revision: 1

Date: 8/11/2004

Page 34/155

As for risk analysis, this document will define an action plan for each identified recommendation derived from lessons learnt. It will clearly identify the milestones (in term of events and dates) to be followed in the schedule. Success or acceptance criteria shall also be identified (such as review completion, activity completion, H/W or S/W installation, ...) to allow a detailed follow-up and formal closure for each action.

Heritage for SVM subsystems [H-SVM] & [P-SVM]

By reusing several existing equipment or units that do not need major modifications in order to be compliant with Herschel/Planck requirements, the development and verification effort may be reduced and therefore no full qualification test programme is necessary. The selection of proposed units and equipment has been done during the Phase B such that a reduction of the AIV effort and costs will result.

The most important heritages are the propulsion subsystem (RCS), the harness, the structures and the Thermal Control, which use well-proven technology and hardware. The layout of these subsystems necessitates adaptations to Herschel and Planck Satellites and has to be qualified for these configurations. But the **unit** qualification programme may be considered as already achieved.

3.5 HERSCHEL/PLANCK COMMONALITY

[H/P]

The Herschel/Planck programme consists in the development of two satellites in a common project with common procurements. In order to meet the objective of cost reduction the design with maximum commonality will be retained when possible even if it is not the technical optimum for one of the two satellites.

Partial or complete commonality is expected for the following items:

- Primary Structure of the SVM
- power supply (same range of power)
- CDMS including software
- RF and TT&C
- RCS components
- solar cells
- basic ACMS sensors
- ACMS basic concept including partially (i.e. common) software
- EGSE and MGSE interfacing with the SVM.

This SVM commonality is supported by the same SVM Contractor for Herschel and Planck.

3.6 MODULAR CONCEPT

[H/P]

In order to make the AIT more flexible and to simplify the system tests, the 2 satellites are divided in modules or assemblies that can be as far as possible tested individually.

- Herschel satellite will be decomposed in 3 modules or subassemblies illustrated by figure 3.7-1:
 - the Service Module (SVM)
 - the Extended Payload Module (E-PLM) including the cryostat, the Sunshade, the Sunshield/Solar Array and the truss interfacing the SVM
 - the Telescope
- Planck satellite will be decomposed in 2 main modules illustrated by Figure 3.7-2:
 - the Service Module (SVM) including the Solar Array subassembly
 - the payload module (PPLM) including the Telescope subassembly, The Baffle and the Cryo-Structure with the truss interfacing the SVM.

3.7 CONTAMINATION

[H/P]

Based on ISO experience, the Cleanliness Specification (refer to AD3-5) is the results of contamination analysis performed up to now.

The contamination budgets will be a driver for the AIT sequences and for the choice of the class of the room or adequate protection to perform critical phases. Specific requirements for the launch campaign up to the launch time is identified/specified be implemented during this period.

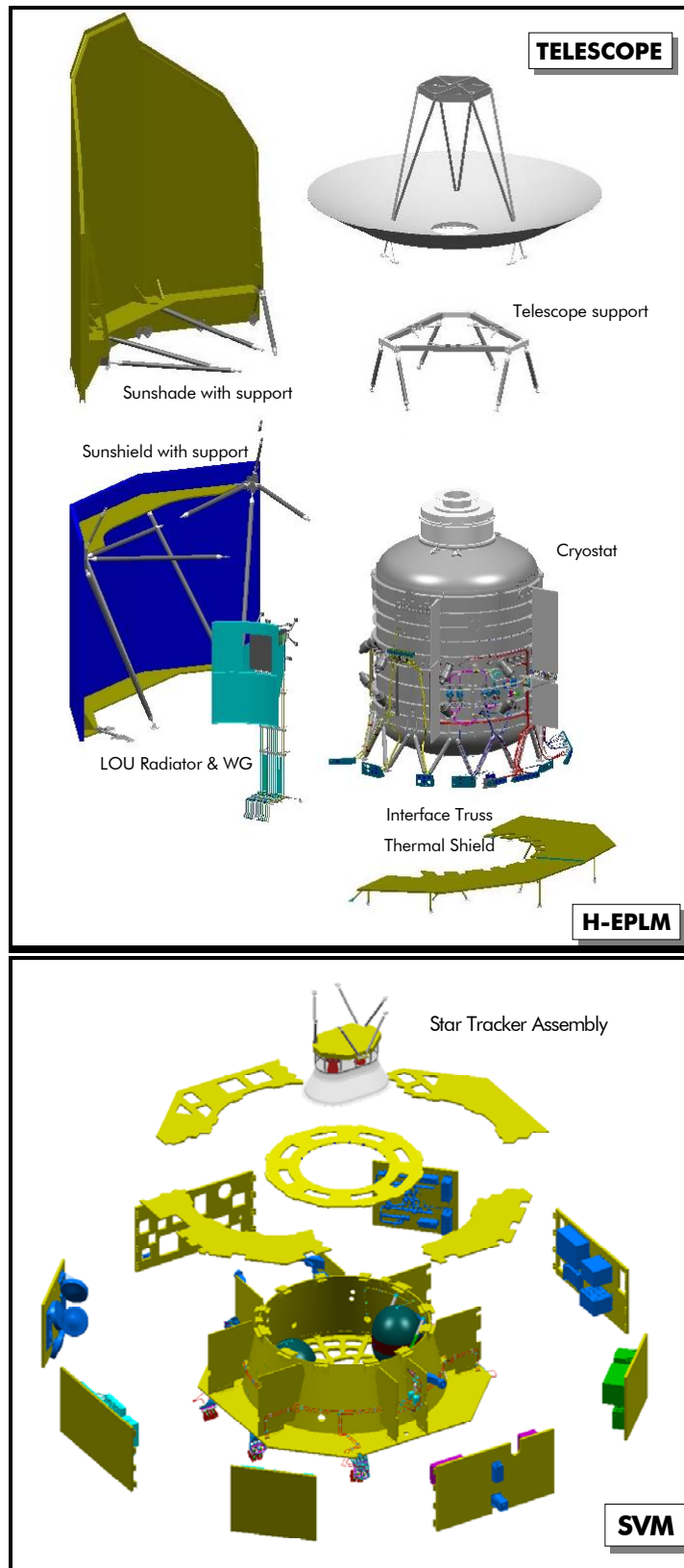

Figure 3.7-1: Exploded view of Herschel

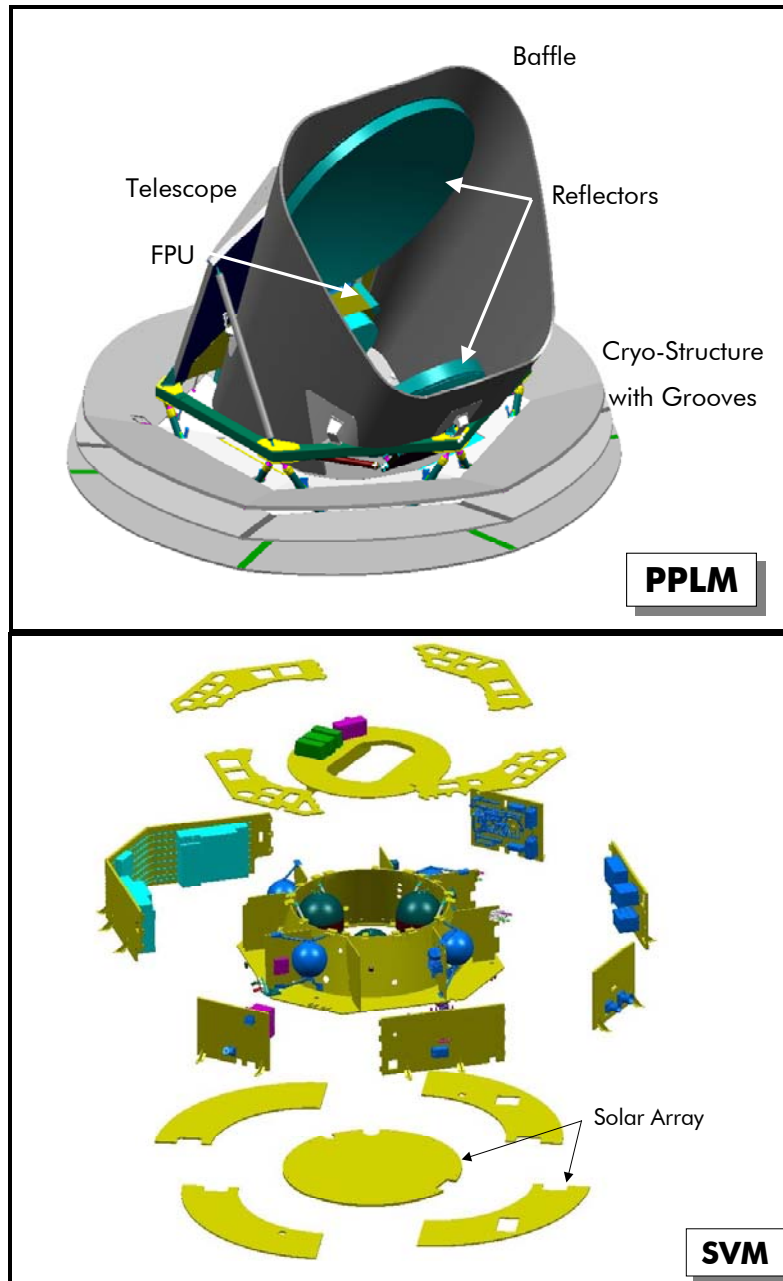

Figure 3.7-2: Exploded view of Planck

4 MODEL PHILOSOPHY DEFINITION

[H/P]

The model philosophy applicable on Herschel is at system level based on:

- a multipurpose Structural & Thermal Model (STM)
- a Flight Model (FM).

The model philosophy applicable on Planck is at system level based on:

- a Proto-Flight Model (PFM).

These models are completed by:

- single purpose Avionics Model (AVM)
- TTC RF Mock-up of Herschel and Planck Satellites

The Satellite models are completed by the followings PLM and telescope development models:

- an Engineering Qualification Model (EQM) and Proto-flight Model (PFM) of the Herschel E-PLM,
- a Cryogenic and RF Qualification Model (CQM/RFQM) and a Flight Model (FM) of the Planck PLM (PPLM),
- a Radio Frequency Development Model (RFDM) of the Planck PLM,
- a Qualification Model (QM) and a Flight Model (FM) of the Planck Telescope
- a Flight Model (FM) of the Herschel Telescope.

The main objectives of each model are given hereafter:

- AVM (Electrical Test Bench):
 - development model for functional design and S/S compatibility
 - development model for on board software validation
 - EMC pre-qualification.

- STM:
 - development model for structure lay-out and certification
 - development model for thermal control certification
 - confirmation of mechanical and thermal environment before flight models testing
- FM:
 - Flight Model for qualification completion in the areas where this qualification has not been completely achieved with the other models, and mechanical/thermal acceptance for flight.
- PFM:
 - Flight Model for qualification with qualification completion in the areas where this qualification has not been completely achieved with module models.
- EQM of Herschel E-PLM (reuse of ISO cryostat):
 - model to provide correct thermal and optical environment for early Herschel instrument testing at PLM level.
- PFM of Herschel E-PLM:
 - Proto-Flight Model for mechanical and thermal qualification of the cryostat at Herschel STM level
- CQM/RFQM of Planck PLM:
 - development model for mechanical and cryogenic qualification (CQM)
 - instrument compatibility and EMC at cryogenic temperature
 - Radio Frequency sub-millimetric performance certification (RFQM).
- RFDM of Planck PLM:
 - specific model built around ARCHEOPS reflectors to validate and correlate the mathematical model.
- TTC RF Mock-up:
 - specific models to verify the RF pattern of the TTC antennas in both configurations.

| The development logic is illustrated by Figure 4.7 and detailed in Chapter 6.

Design & Development Plan (DDP)

Doc. n° H-P-1-ASPI-PL-0009
 Issue: 4 / Revision: 1
 Date: 8/11/2004
 Page 41/155

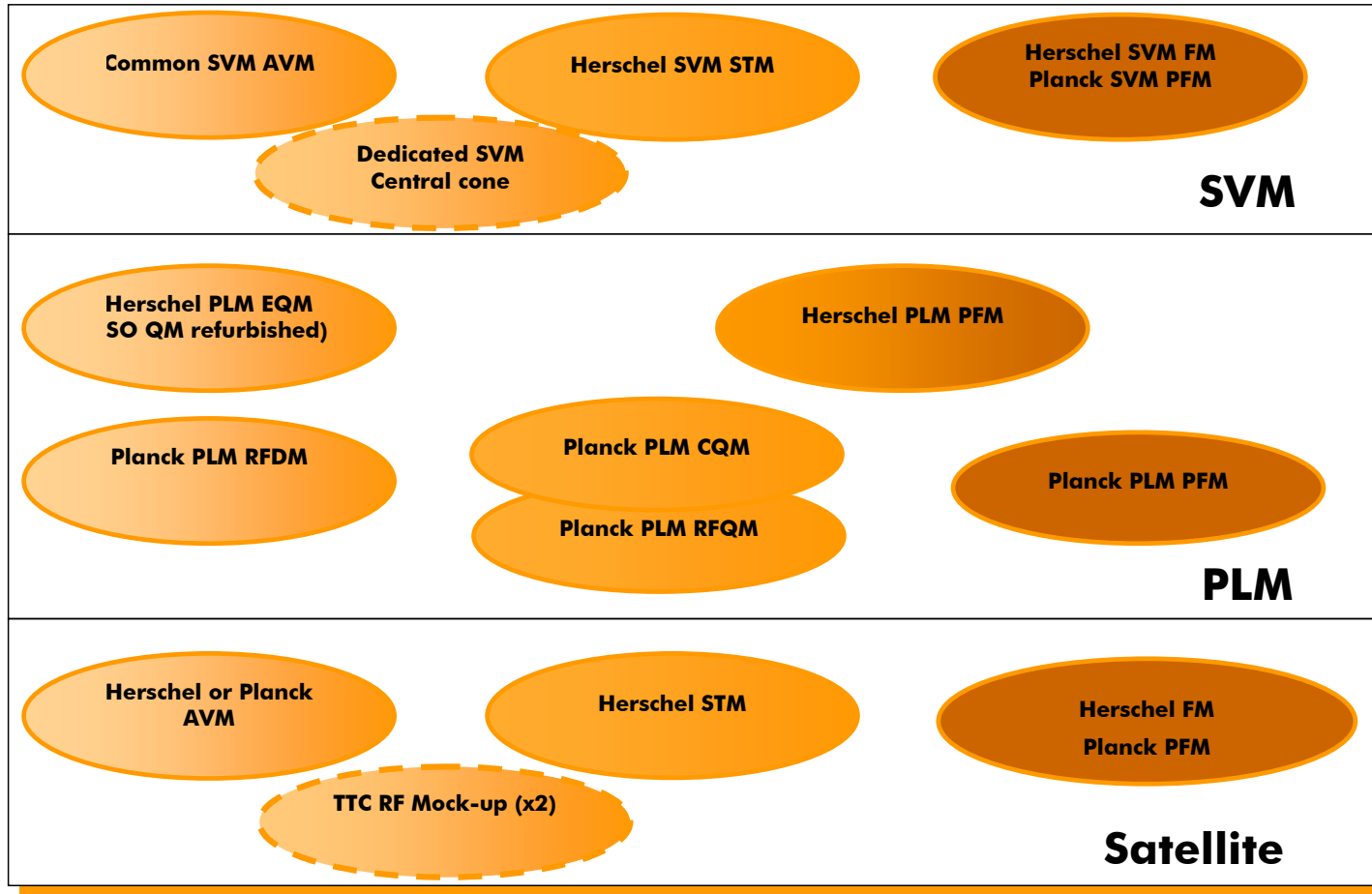

Figure 4.7: Development logic

5 AIT/AIV ORGANIZATION

[H/P]

As prime Contractor ALCATEL Space will manage the overall AIV of Herschel and Planck.

It will build the verification programme plan including the verification matrices and will manage the verification control documents. It will specify the requirements of higher level for MGSE and EGSE with emphasis into the commonality.

The SVM AIV and AIT will be under the responsibility of the SVM Contractor: Alenia SPAZIO. It will procure the common MGSE and EGSE used at SVM, Herschel E-PLM and satellite, and Planck PLM and satellite. It will also deliver fully integrated and electrically tested SVMs.

In order to limit transport activities and to simplify the interface, it is proposed to have the same AIV Contractor respectively at Herschel E-PLM and satellite levels, and at Planck PLM and satellite levels.

- Astrium-ED will be responsible for the AIV & AIT of the Herschel E-PLM and for the AIT of the Herschel satellite (refer to Table 5-1). It will procure specific MGSE for Herschel E-PLM and satellite integration and test.
- ALCATEL Space will be responsible for the AIV of the Herschel satellite (refer to Table 5-1).
- ALCATEL Space will be responsible for the AIV & AIT of the Planck PLM and the Planck satellite. It will procure specific MGSE for Planck PLM and satellite integration and test.

In order to take benefit of SVM AIT (lessons learnt) for Satellite AIT and thus to increase efficiency, it is proposed to carry out both SVM and satellite AIT with mixed teams from SVM Contractor and from respective Herschel and Planck AIT Contractors.

Design & Development Plan (DDP)

Doc. n° H-P-1-ASPI-PL-0009

Issue: 4 / Revision: 1

Date: 8/11/2004

Page 43/155

Herschel	VPP		TEST SEQUENCE	TEST SPECIFICATION	TEST PROCEDURE	TEST EXECUTION	TEST REPORT	TEST EVALUATION
	H/W & TEST CONFIGURATION	DEFINITION OF TEST						
Assembly	ALCATEL	N/A	Astrium	N/A	Astrium	Astrium	Astrium	N/A
Mechanical	ALCATEL	ALCATEL	Astrium	ALCATEL	Astrium	Astrium	Astrium	ALCATEL
Thermal	ALCATEL	ALCATEL	Astrium	ALCATEL + SVM Contractor	Astrium	Astrium	Astrium	ALCATEL + SVM Contractor
Functional	ALCATEL	ALCATEL	Astrium	ALCATEL + SVM Contractor	Astrium + SVM Contractor support	Astrium	Astrium	ALCATEL + SVM Contractor
Instruments	ALCATEL + Instruments	ALCATEL + Instruments	Astrium + Instruments	Instruments	Astrium* + Instruments	Astrium* + Instruments	Astrium* + Instruments	Instruments
EMC	ALCATEL	ALCATEL	Astrium	ALCATEL + SVM Contractor + instruments	Astrium	Astrium	Astrium	ALCATEL + SVM Contractor + instruments
SVT-1 & -2	ALCATEL	ALCATEL	ESOC	ESOC	ESOC + Astrium Support	ESOC + Astrium Support	ESOC	ESOC
EPLM	ALCATEL + Astrium	ALCATEL + Astrium	Astrium	Astrium	Astrium	Astrium	Astrium	Astrium
Alignment	ALCATEL	ALCATEL + Astrium**	Astrium	ALCATEL + Astrium**	Astrium	Astrium	Astrium	ALCATEL + Astrium**

* Astrium for spacecraft related aspects (He II conditions, overall S/C configuration a.s.o.).

** Astrium for E-PLM and telescope aspects.

*** deleted

Table 5-1: AIV responsibilities for Herschel Satellite

**Design & Development Plan
(DDP)**

Doc. n° H-P-1-ASPI-PL-0009
 Issue: 4 / Revision: 1
 Date: 8/11/2004
 Page 44/155

Planck	VPP		TEST SEQUENCE	TEST SPECIFICATION	TEST PROCEDURE	TEST EXECUTION	TEST REPORT	TEST EVALUATION
	H/W & TEST CONFIGURATION	DEFINITION OF TEST						
Assembly	ALCATEL	N/A	ALCATEL	N/A	ALCATEL	ALCATEL	ALCATEL	N/A
Mechanical	ALCATEL	ALCATEL	ALCATEL	ALCATEL	ALCATEL	ALCATEL	ALCATEL	ALCATEL
Thermal	ALCATEL	ALCATEL	ALCATEL	ALCATEL+ SVM Contractor	ALCATEL	ALCATEL	ALCATEL	ALCATEL + SVM Contractor
Functional	ALCATEL	ALCATEL	ALCATEL	ALCATEL + SVM Contractor	ALCATEL + SVM Contractor	ALCATEL**	ALCATEL	ALCATEL + SVM Contractor
Instruments	ALCATEL + Instruments	ALCATEL + Instruments	ALCATEL + Instruments	Instruments	ALCATEL + Instruments	ALCATEL + Instruments	ALCATEL + Instruments	Instruments
EMC	ALCATEL	ALCATEL	ALCATEL	ALCATEL + SVM Contractor + instruments	ALCATEL	ALCATEL	ALCATEL	ALCATEL + SVM Contractor + instruments
SVT-1 & -2	ALCATEL	ALCATEL	ESOC	ESOC	ESOC + ALCATEL Support	ESOC + ALCATEL Support	ESOC	ESOC
PLM	ALCATEL	ALCATEL	ALCATEL	ALCATEL	ALCATEL	ALCATEL	ALCATEL	ALCATEL
Alignment	ALCATEL	ALCATEL	ALCATEL	ALCATEL	ALCATEL	ALCATEL	ALCATEL	ALCATEL

** After the first IST. Mating verifications and first IST to be made by Alenia with ALCATEL support.

Table 5-2: AIV responsibilities for Planck Satellite

Design & Development Plan (DDP)

Doc. n° H-P-1-ASPI-PL-0009

Issue: 4 / Revision: 1

Date: 8/11/2004

Page 45/155

[AVM] Configuration	Tests	Specification	Procedure	Execution	Report	Evaluation
[CS-AVM]	SVM Common S/S I & T and UFT	ALENIA	ALENIA	ALENIA	ALENIA	ALENIA
	SVM Common VMC I & T and UFT	ALCATEL	ALENIA (2)	ALENIA	ALENIA	ALCATEL
	SVM Common SREM I & T and UFT	ESA (2)	ALENIA	ALENIA	ALENIA	ESA (2)
	SVM Common S/S SIT	ALENIA	ALENIA	ALENIA	ALENIA	ALENIA
[PS-AVM]	SVM Specific Planck ACMS units I & T and UFT	ALENIA	ALENIA	ALENIA	ALENIA	ALENIA
	FOG I & T and UFT	ESA (2)	ALENIA	ALENIA	ALENIA	ESA (2)
	SVM Specific Planck ACMS units SIT	ALENIA	ALENIA	ALENIA	ALENIA	ALENIA
[P-AVM]	Planck [I-WU-AVM] I & T	ALENIA	ALENIA	ALENIA	ALENIA	ALENIA
	Planck [I-WU-AVM] UFT	ALCATEL (1)	ALENIA (2)	ALENIA	ALENIA	ALCATEL (1)
	SVM Planck IST	ALENIA	ALENIA	ALENIA	ALENIA	ALENIA
	SVM Planck EMC Conducted Test	ALENIA (3)	ALENIA	ALENIA	ALENIA	ALENIA (3)
	Planck Satellite IST TBC	ALCATEL (1)	ALCATEL (4)	ALCATEL (4)	ALCATEL (4)	ALCATEL (1)
	Planck SVT-0	ESOC	ESOC (4)	ESOC (4)	ESOC (4)	ESOC
[HS-AVM]	SVM Specific Herschel ACMS units I & T and UFT	ALENIA	ALENIA	ALENIA	ALENIA	ALENIA
	SVM Specific Herschel ACMS units SIT	ALENIA	ALENIA	ALENIA	ALENIA	ALENIA
[H-AVM]	Herschel [I-WU-AVM] I & T	ALENIA	ALENIA	ALENIA	ALENIA	ALENIA
	Herschel [I-WU-AVM] UFT	ASTRIUM (1)	ALENIA (6)	ALENIA	ALENIA	ASTRIUM (1)
	Herschel CCU I & T and UFT	ASTRIUM	ALENIA (6)	ALENIA	ALENIA	ASTRIUM
	SVM Herschel IST	ALENIA	ALENIA	ALENIA	ALENIA	ALENIA
	SVM Herschel EMC Conducted Test	ALENIA (3)	ALENIA	ALENIA	ALENIA	ALENIA (3)
	Herschel Satellite IST TBC	ALCATEL (1)	ASTRIUM (4)	ASTRIUM (4)	ASTRIUM (4)	ALCATEL (1)
	Herschel SVT-0	ESOC	ESOC (4)	ESOC (4)	ESOC (4)	ESOC

(1) with Instrument support
(3) with ALCATEL approbation
(5) with ESA support

(2) with ALCATEL support
(4) with ALENIA support
(6) with ASTRIUM support

Table 5-3: AIV responsibilities for AVM

6 MODEL PHILOSOPHY AND DEVELOPMENT

6.1 INTRODUCTION

[H/P]

The baseline model philosophy is defined:

- to allow by means of appropriate models the full qualification of each unit and subsystem together with the formal qualification of the overall satellite
- to define a realistic development sequence in order to guarantee the availability in due time for launch and in the cost envelope, of a flight model compliant with all system requirements
- to ensure through a series of verifications performed at each level, all along the development sequence, that the design is really suitable and compliant with the mission requirements.

This model philosophy is based on the conclusions of the previous trade-offs from which it is proposed to support the requirements for development, qualification and final flight acceptance of the Herschel and Planck satellites.

The proposed system model philosophy: AVM/STM/FM-PFM allows to optimise the cost, the risk and the schedule aspects of the Herschel/Planck programme. It is compatible with delivered models for the Customer furnished equipment (instruments, Herschel telescope and Planck reflectors).

This approach is summarised by Figures 6.1-1 & 6.1-2.

Design & Development Plan (DDP)

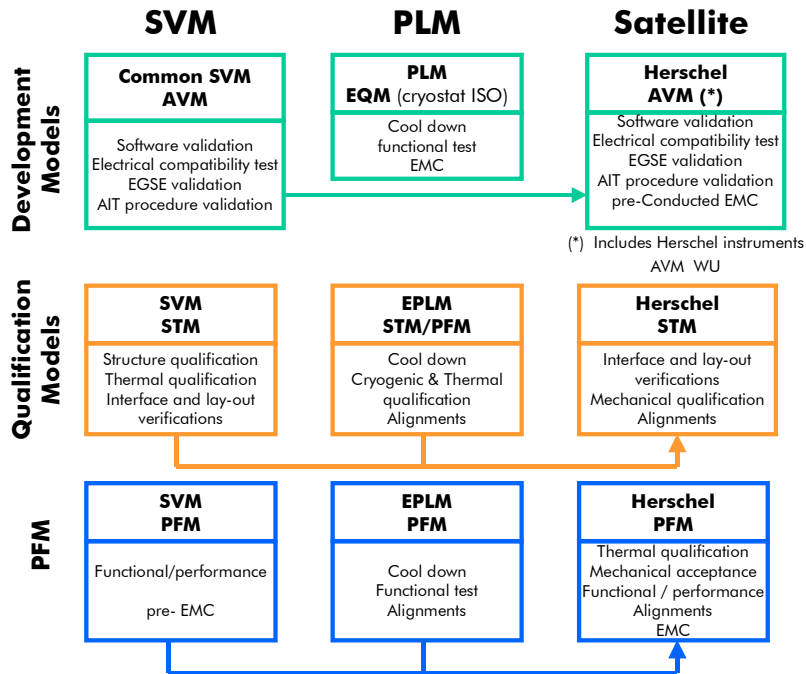

FIGURE 6.1-1: Model Philosophy for Herschel

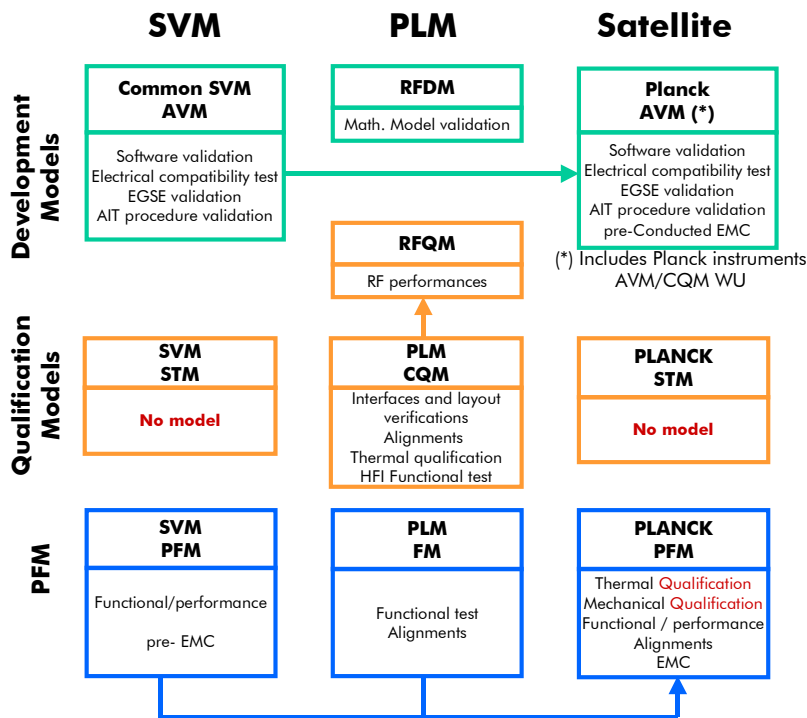

FIGURE 6.1-2 Model Philosophy for Planck

6.2 SYSTEM DEVELOPMENT MODELS

6.2.1 Structural & Thermal Model

STM test objectives

[H/P]

The Mechanical and Thermal, including cryogenic, qualification tests sequence of Herschel and Planck Satellites is summarised in figure 6.2.1.

STM shall be used:

- for structural development and qualification tests,
- for thermal control and cryogenic qualification tests.

These tests allow validating at an early stage the specified mechanical & thermal environments.

In addition, STM will validate:

- the optical alignment performances and their stability regarding mechanical and thermal/cryogenic environment,
- the mass properties.

Taking into account the thermal separation between SVM and PLM, the two satellites will be pre-qualified regarding thermal environment during TV/TB (Thermal Vacuum/Thermal Balance) tests to be performed at module levels.

The system thermal qualification with flight hardware (including SVM electronic units) will be performed at Satellite PFM level **for Planck and Satellite FM level for Herschel.**

The mechanical qualification will be performed only at Satellite level. Structural parts, harness connections, instrument piping, RF cabling and wave-guides will be mechanically qualified through tests performed at Satellite level as well as the new arrangement of the “off-the-shelf” RCS components.

[P-Sat] [P-SVM]

For programmatic reason to re-establish a credible baseline schedule, there is no Planck STM nor at Satellite, nor at SVM level. The above objectives are fulfilled thanks to:

- commonality between the SVM of Herschel and Planck,
- dedicated tests on Planck PLM CQM.

Associated analysis of induced risks and their mitigation are addressed in document [RD8].

[H-SVM] [P-SVM]

The mass properties of both SVM will be validated through dedicated measurements performed at their level. This allows:

- preparing the pre-balancing of the Planck Satellite to cope with the balancing machine capability,
- confirming the no-need of balancing masses for Herschel Satellite
- accommodating expected balancing masses for both satellites mechanical testing

Thermal and Cryogenic Environment Testing

[H/P]

For both Satellites, the thermal qualification will be in two steps:

- thermal vacuum/thermal balance test on Herschel STM SVM alone allowing correlation of both SVM thermal models,
- thermal vacuum/thermal balance test on both PLM allowing correlation of the thermal model and assessment of the thermal performances.

[P-SVM]

In addition, peculiarities of Planck SVM thermal control not validated through TV/TB test on Herschel SVM STM such as:

- Solar Array radiative effect,
- PAU/BEU environment,
- SCC Radiator,
- 4K compartment,

will be verified thanks to the advanced step #1 of the Planck PFM thermal testing in CSL necessary to verify the functionality of the SCC Redundant. As, for this step, the full FM instrument delivery is not mandatory, to do it at early stage gives some flexibility in the overall schedule.

Herschel SVM STM built standard

[H-SVM]

The Herschel SVM STM shall consist of structural and thermal hardware with flight standard design and configuration equipped with:

- mass & thermal dummies (MTD) for subsystem units and Warm Units of scientific instruments, accurately simulating unit masses, dimensions, centre of gravity, and thermal dissipation,
- at least flight standard RCS fill & drain valves, tank and tubing since the RCS tanks shall be filled with a propellant simulator during Satellite STM mechanical tests,
- mass representative electrical harness, RF cabling and wave-guides, Harness and RF cabling shall be mounted to the STM with flight representative brackets/fixations and shall give representative loads to the STM structure,
- Dummy of the lower part of the HSS (Sunshield/Sunshade) to simulate its shadowing during the TV/TB test at SVM level.

Design & Development Plan (DDP)

Doc. n° H-P-1-ASPI-PL-0009

Issue: 4 / Revision: 1

Date: 8/11/2004

Page 51/155

Planck PLM CQM built Standard **[P-PLM]**

There is a strong link between the PPLM and the PSVM due to the design of the instruments with their warm part to be accommodated inside the SVM. In order to allow performing parallel thermal qualification of the PLM and of the SVM, a dedicated SVM dummy accommodating all the warm units of the instruments is used for the qualification phase of the PPLM cryogenic testing.

During the PPLM CQM test program, the LFI instrument will be not present, so:

- The Sorption Cooler Compressor (SCC) is replaced by a dedicated fluidic GSE filled with gaseous hydrogen named "PACE-GSE" simulating the SCC nominal fluidic behaviour
- a RAA STM replaces the non-delivered item to achieve objectives of the test by providing HFI and SCS-PACE with mechanical and thermal interfaces. These interfaces will provide the proper stiffness and thermal de-coupling and will guarantee the proper alignment of the HFI detector with the Telescope Focal Plane.

The QM telescope is equipped with dummy Reflectors during CQM Planck PLM acoustic sequence but without any Reflectors during thermal/cryogenic sequence . The QM reflectors will be only used during RFQM test.

The three main objectives of the PPLM CQM thermal/cryogenic testing are:

- Verification of the "passive" thermal performances of the PPLM (Cryo-Structure + Telescope)
- Verification of the active cooling chain (50K -> 20K -> 4K -> 0.1K)
- Functional testing of the HFI instrument

In case of late delivery of the HFI CQM delivery, the PPLM CQM sequence can be split into 2 steps (first one without HFI during the facility acceptance test and second one with HFI) in order to check as soon as possible the passive performances of the PPLM. (To Be Confirmed)

As the redundant chain of the Sorption Cooler System are not verified during the CQM sequence (previous baseline), both SCC, nominal and redundant, shall have to be verified during the PFM sequence that needs two cool down sequences.

Herschel EPLM STM built Standard

[H-EPLM]

The possible configurations of the STM Herschel EPLM during TV/TB test have been traded-off (refer to [RD3]). Pending additional analyses in progress at EADS-astrium, the baseline is to perform the test with the following configuration:

- PLM PFM with MTD instruments (FPU, LOU) and PFM LOU Radiator
- HSS STM
- Telescope TM (M1 only) and PFM Mounting Structure
- SVM shield assembly PFM
- MLI (CVV, HSS, struts)
- SVM replaced by a Thermal Test Adapter simulating heat load from SVM

This test will be performed with an “actively cooled shrouds” (also called “Anti-radiator”) in front of the CVV. This allows verifying the cryogenic lifetime performance in orbital condition, taking into account all contributors including the cryostat external TC.

The need of GHe heat exchanger on CVV is pending on thermal analysis of set-up

Mechanical Environment Testing

Static Testing

[H-SVM]

In order to anticipate any structural problem and thus to avoid any risks of PLM hardware degradation (PFM cryostat for Herschel and CQM instruments for Planck) the Primary Structure alone will be mechanically tested prior to system test. Thank to the communality of Herschel and Planck Primary Structures, this Static Load Test will be performed only on the Herschel Primary Structure STM, the validation of both SVM structures being done by similarity and analysis.

Sine and Acoustic Testing

[H-Sat]

Herschel STM will undergo sine and acoustic environment as defined [in AD2-1] at qualification levels.

[P-Sat] & [P-SVM]

As there is no Planck STM, Planck PFM will undergo sine and acoustic environment as defined [in AD2-1] with proto-flight levels.

Due to commonality between both SVM, acoustic testing on Herschel STM will provide information regarding acoustic environment response of Planck SVM.

[P-PLM]

In order to confirm at an early stage the random vibration level at Planck FPU interface, a preliminary acoustic test is performed on the PPLM built for TV/TB test purpose with the SVM dummy and both STM FPU.

Shock Environment Qualification

[H/P]

For Herschel and Planck, the only source of shock is the launcher. There is no device allowing performing a shock test on Satellite neither at acceptance/flight level nor at qualification level. So the demonstration of the Herschel and Planck ability to withstand the shock generated by the launcher will be achieved in three steps through qualification tests performed at equipment level, shock characterisation on Herschel STM Satellite (due to commonality of both SVM) and analytic demonstration.

First step: Qualification test to be performed at equipment level.

This test can be a shock test or another mechanical environment qualification test (i.e. random or sine) pending the predicted shock level to be experienced at the interface

of the equipment with the structure and defined in the Environmental and Test Specification.

Second step: Shock test characterisation.

By generating a shock at the Satellite/Launcher interface, this test allows to measure interface levels and equipment base levels.

According to Arianespace, this test can be performed once. As the STM of Herschel provides a satellite structure close to the interface (i.e. primary structure of the SVM) and equipment locations and mounting fully flight representative of both satellites, the shock generation is only performed on this model and obtained by a Shock Generation Unit (SHOGUN) followed by a clamp-band release with a drop test. Shock test on Herschel Satellite STM is combined with mechanical fit-check.

A mechanical fit-check with flight ACU will be performed in Europe on Planck PFM Satellite. According ability of WU instruments to withstand additional shock environment, a clamp-band release with a drop test will be performed in combination of this fit-check.

The SHOGUN test is only performed on Herschel STM to avoid over-stressing of flight equipment as the generated shock by this device can be higher than the expected flight one.

Third step: Analytic demonstration of the qualification of the equipment.

This is obtained by comparing the equipment qualification levels (step #1) to the equipment base levels experienced applying the interface shock to be defined by Arianespace and the transfer functions deducted from the shock characterisation test (step #2). The Herschel and Planck ability to withstand the shock is achieved if a qualification margin of 3dB is demonstrated by comparison.

Herschel STM built standard
[H-Sat] & [H-EPLM]

The Herschel STM will be composed of:

- the STM of the Herschel SVM built for TV/TB test at SVM level
- the STM of the Herschel E-PLM including the PFM Cryostat equipped with dummy FPU's, STM HSS (Sunshade/Sunshield) built for TV/TB test at E-PLM level
- A telescope SM

**Design & Development Plan
(DDP)**

Doc. n° H-P-1-ASPI-PL-0009

Issue: 4 / Revision: 1

Date: 8/11/2004

Page 55/155

Planck STM built standard

[P-Sat] & [P-SVM]

deleted

Design & Development Plan (DDP)

Doc. n° H-P-1-ASPI-PL-0009
 Issue: 4 / Revision: 1
 Date: 8/11/2004
 Page 56/155

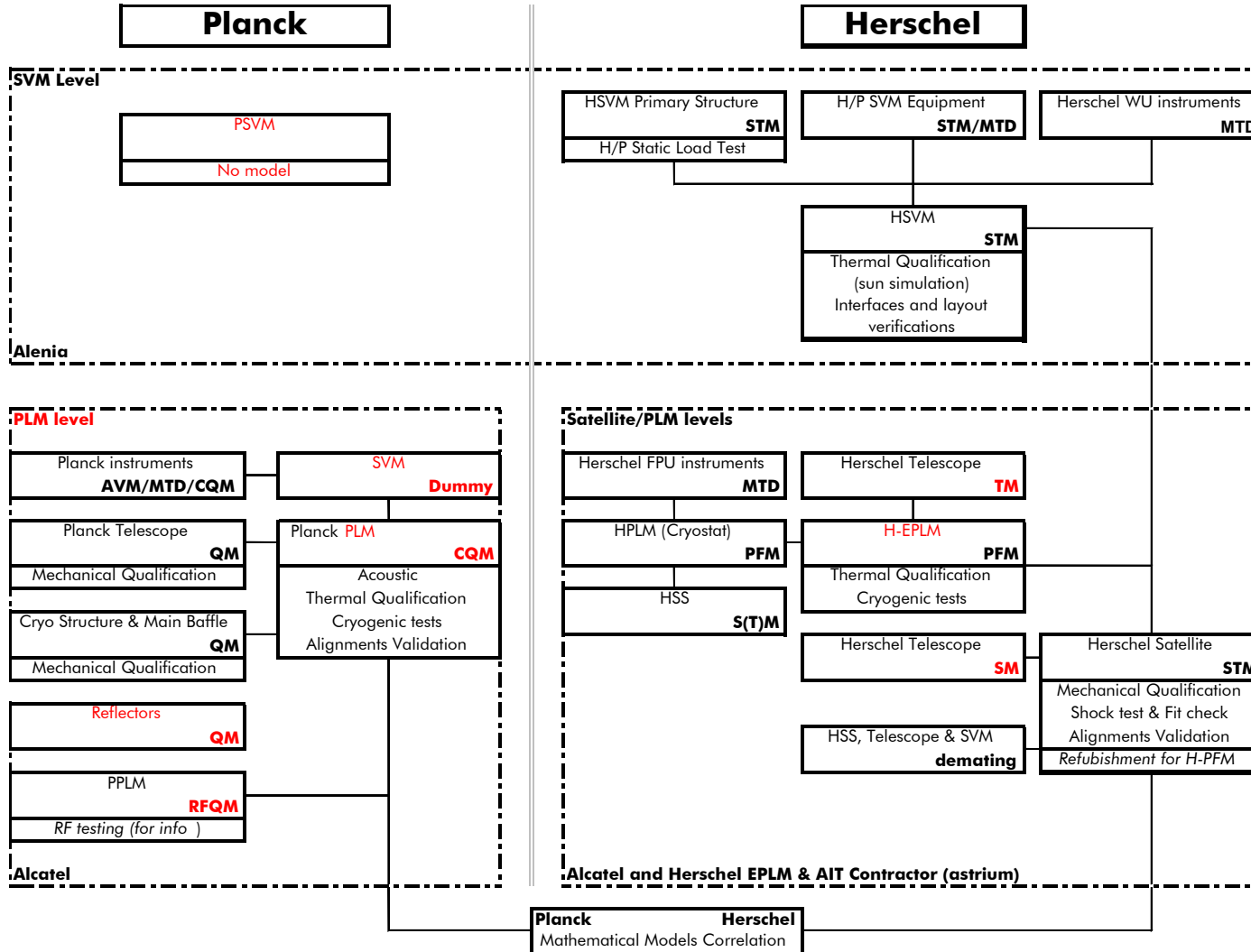

Figure 6.2.1 Mechanical and Thermal, including cryogenic, qualification tests sequences of Herschel and Planck Satellites

6.2.2 AVionics Model (AVM)

[H/P]

For responsibility sharing, refer to Table 5-3

The Avionics Model is a bench model on which will be installed the electrical equipment of Herschel/Planck SVM subsystems and the Herschel/Planck Instruments "Warm" Units.

All items building it will be flight representative in electrical I/F and functionality.

Only one AVM is proposed to be used either in the Herschel configuration (equipped with Herschel ACMS and with Herschel instruments AVM) or in the Planck configuration (equipped with Planck ACMS and with Planck instrument AVM).

The AVM will be kept operational all along the AIT sequence to be usable for potential failure analysis or for validation of software modification.

AVM build standard

The AVM model set-up is shown in the Figure 6.2.2-1.

This model is based at three main parts, namely:

- Common SVM AVM including the common Herschel/Planck avionics subsystems like CDMS, Power S/S (batteries and PCDU), RF S/S and the common ACMS units (i.e. ACC computer and sensors units).
- Herschel and Planck SVM AVM including the specific units of Herschel and Planck in order to reach the related full SVM configuration both for Herschel and Planck, namely : specific ACMS Sensors and Actuators
- Herschel and Planck Satellite AVM including the relevant Instruments "Warm" Units

The AVM will be developed in order to allow the maximum flexibility between Herschel and PLANCK testing in terms to swap from Herschel to PLANCK configuration and vice-versa changing the H/W and S/W configurations in a short time, typically 48 hours.

For this the following capabilities will be implemented:

- Quick S/W loading on Avionics on board computer, ACC and CDMU, in order to quickly modify the S/W configuration from Herschel to PLANCK and vice-versa.
- I/F Connectors that allow to integrate easily the AVM Common Elements and the AVM Modular Elements.

**Design & Development Plan
(DDP)**

Doc. n° H-P-1-ASPI-PL-0009
Issue: 4 / Revision: 1
Date: 8/11/2004
Page 58/155

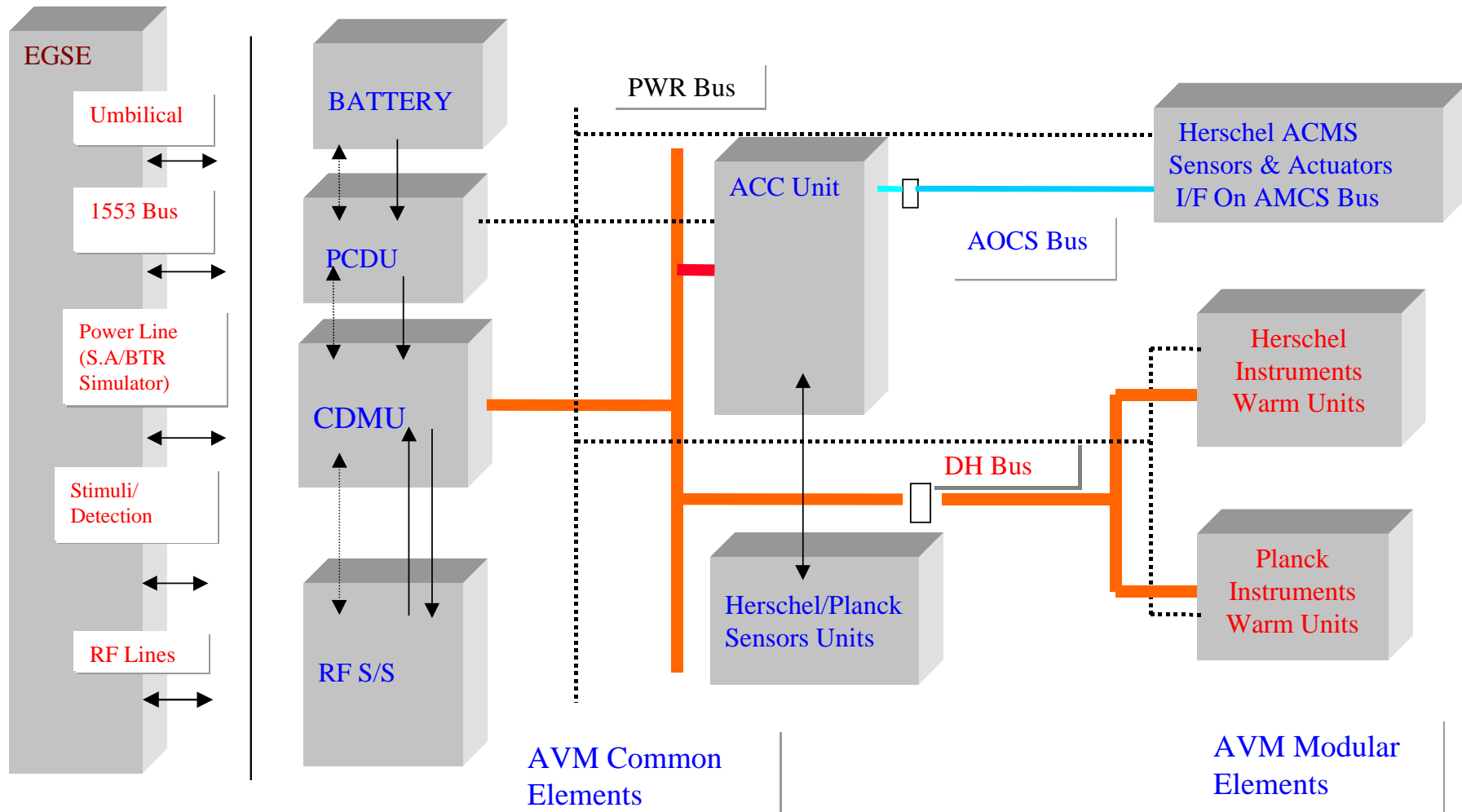

Figure 6.2.2-1: AVM Set-up

AVM Test objectives

The electrical system validation sequence is illustrated by Figure 6.2.2-2.

The main objectives of the AVM are:

- Check the electrical and functional interfaces between the units.
- Verify the functionality of the avionics subsystems and on-board software including the closed loop tests for ACMS functional verifications, prior to FM implementation.
- S/C autonomy functional verification and validation of the On-Board Control Procedure (OBCP).
- Preliminary validation of communication and power interfaces between the Herschel/PLANCK Instruments Warm Units and the CDMS and EPS S/S.
- Test the EGSE – SVM interfaces including the EGSE software and verify the EGSE capability to perform the planned test.
- Validation of the test sequence to be re-used for PFM/FM test campaign
- Perform EMC Conducted test on avionics units.

Specific tasks (i.e. EGSE operations, overall electrical performances...) to be also done at Satellite AIT levels will be performed by an integrated team with the participation of involved SVM and Satellite AIT contractors.

In this manner it will realise an optimisation and flexibility on the PFM/FM test activity for what concerns the S/W debugging and re-validation.

The AVM will be maintained operational for trouble shooting up to the IOCR.

SVT-0 will be performed on the AVM after completion of the AVM campaign.

After that it could be delivered at ESOC as ground reference model.

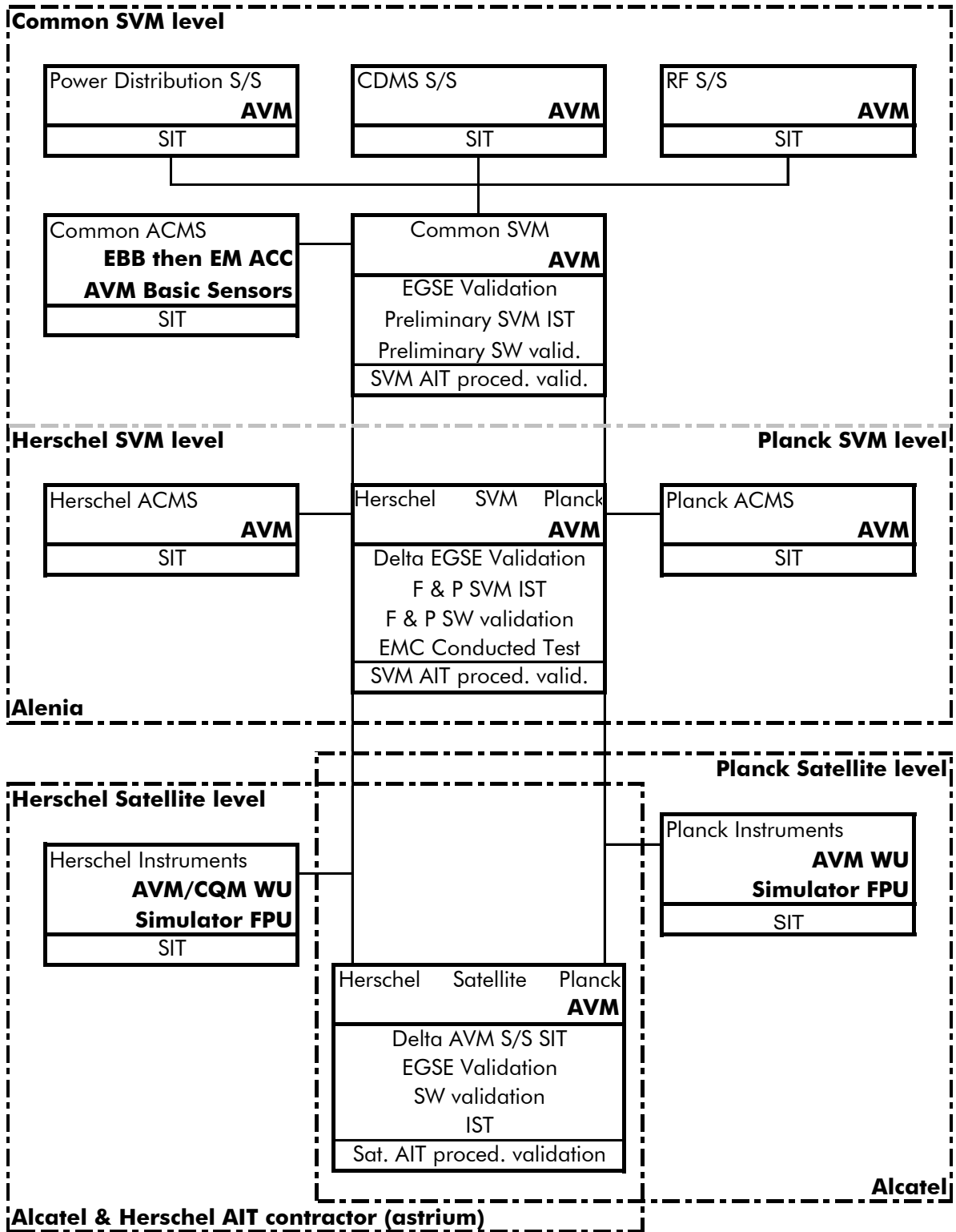

Figure 6.2.2-2: Electrical System Validation Sequence

6.2.3 Flight Model (PFM/FM)

[H/P]

The **Flight Model** will be subject to the system level acceptance/qualification sequence. All its equipment and units are Flight Models (FM) which will have passed acceptance testing as required and proto-flight equipment (PFM) which will have passed qualification testing at unit or sub-system level.

As a consequence, the **Planck PFM** satellite will undergo mechanical **qualification levels with acceptance duration when the Herschel FM satellite will only undergo mechanical acceptance.**

Formal acceptance for launch is established after successful verification of performances during system acceptance/qualification tests with the integrated system.

SVT-0 is performed on AVM and SVT-1 & -2 at Satellite level.

Figure 6.2.3-1 summarises the verification sequence of the Herschel **FM** and Planck PFM. Figure 6.2.3-2 summarises the EMC verification including tests to be performed at module level. EMC CS is only performed at lower levels. At Satellite level, EMC CS is covered by EMC CE and adequate margin in the measured profile. Details are provided with [AD3-19] & [AD3-20].

Herschel FM

The Herschel FM will be composed of:

- the FM of the Herschel SVM accommodating the Instruments FM WU's
- the PFM of the Herschel E-PLM including the PFM Cryostat equipped with PFM FPU's, FM Sunshade and FM Sunshield
- the FM telescope

Planck PFM

The Planck PFM will be composed of:

- the PFM of Planck SVM including the FM Solar Array and accommodating the Instruments FM WU's
- the FM PPLM including the FM telescope and the FM Cryo-structure and accommodating the Instruments FM FPU's.

Design & Development Plan (DDP)

Doc. n° H-P-1-ASPI-PL-0009
Issue: 4 / Revision: 1
Date: 8/11/2004
Page 62/155

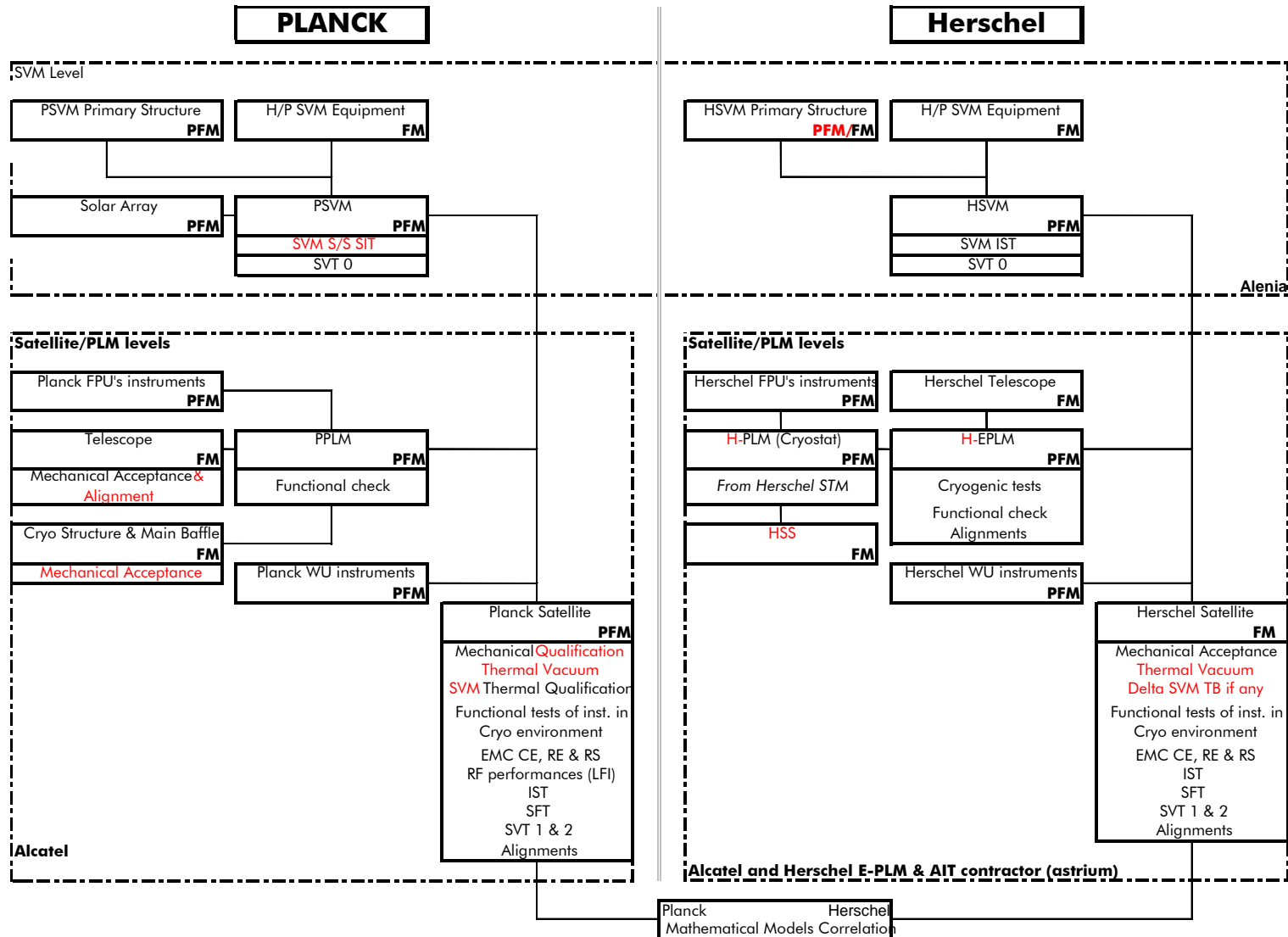

FIGURE 6.2.3-1 Verification sequence of the Herschel FM and Planck PFM.

Design & Development Plan (DDP)

Doc. n° H-P-1-ASPI-PL-0009
Issue: 4 / Revision: 1
Date: 8/11/2004
Page 63/155

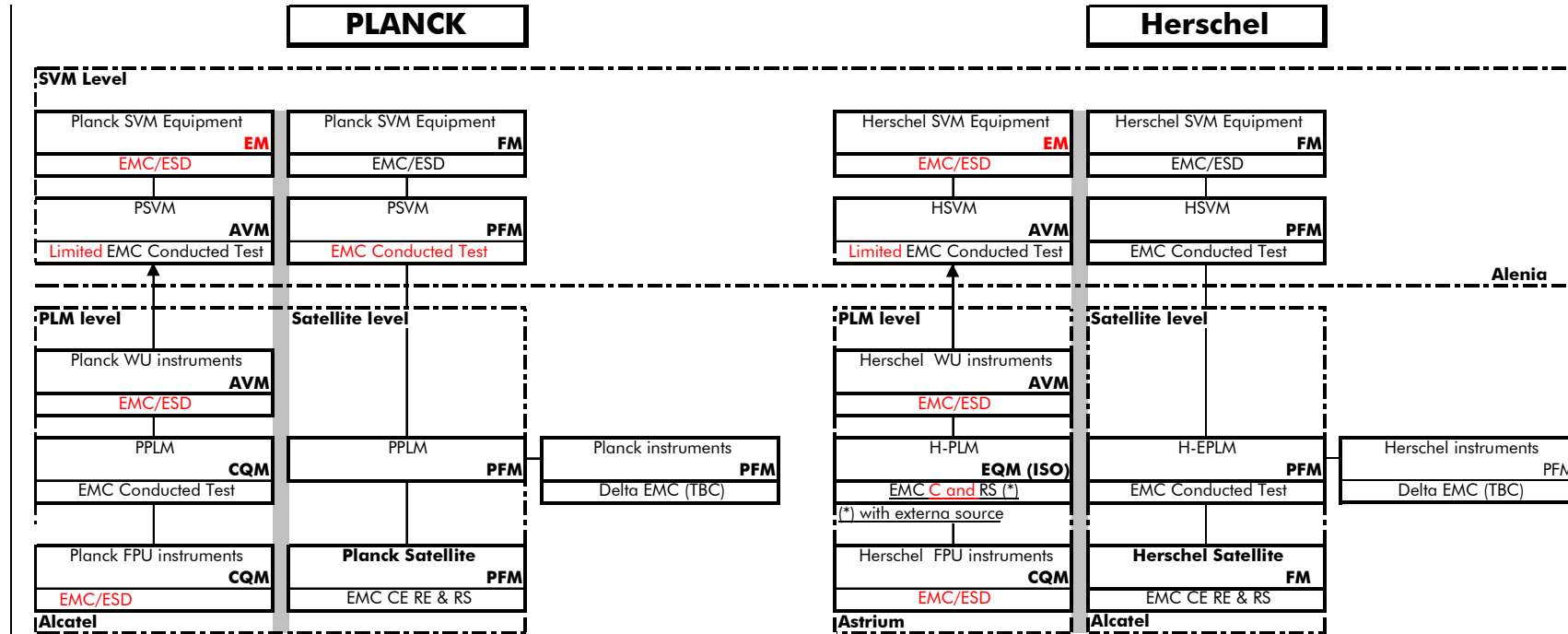

FIGURE 6.2.3-2: EMC/ESD verification

6.2.4 Test Matrix - Summary

6.2.4.1 Satellite level

[H/P]

Test	AVM	Herschel		Planck	
		STM	FM	STM	PFM
Sine & Acoustic	-	Q	A	-	Q
Shock test	-	X	(**)	-	X (**)
Fit check	-	X	-	-	X
Balancing	-	-	-	-	X
Mass properties	-	M, C, I	M, C in plane	-	M, C, I
Alignments	-	X	X	-	X
Thermal Balance w/o Sun Simul.	-	-	ΔQ on SVM A on PLM	-	Q on SVM A on PLM
Thermal cycling	-	-	A	-	A
He Leak test	-	X	X	-	X
RCS Leak test	-	X	X	-	X
Functional tests of instruments in Cryogenic env.	-	-	X	-	X
ESD	-	-	On equipment	-	On equipment
EMC CS	-	-	On equipment	-	On equipment
EMC CE	X (*)	-	X	-	X
EMC RE-RS	-	-	X	-	X
RF perfos.	-	-	-	-	LFI low freq.
TTC RF diagram	-	on RF mock-up		on RF mock-up	
IST	X	-	X	-	X
SFT	-	-	X	-	X
SVT	SVT 0	-	SVT 1 & 2	-	SVT 1 & 2

X = test performed with:

Q= qualification level when relevant

A = acceptance level when relevant

"-" = no test

(*) = if relevant according test performed at unit level

(**) Q on equipment and final qualification achieved by analysis

M = Mass measurement, C = Centring measurement (CoG), I = Inertia measurement.

= test performed at lower level

Table 6.2.4-1: Herschel & Planck Satellites – Test matrix

**Design & Development Plan
(DDP)**

Doc. n° H-P-1-ASPI-PL-0009

Issue: 4 / Revision: 1

Date: 8/11/2004

Page 65/155

6.2.4.2 SVM level

[SVM]

Test	AVM	Herschel		Planck	
		STM	FM	STM	PFM
Static test	-	Test performed on a dedicated Primary Structure covering both Herschel and Planck			
Mass properties	-	X	-	-	-
Alignments	-	X	X	-	X
TV/TB test with Sun Simulation	-	Q	-	-	-
RCS Leak test	-	X	X	-	X
ESD	-	-	On equipment	-	On equipment
EMC CS	-	-	On equipment	-	On equipment
EMC CE	X (*)	-	X	-	-
I&T and UFT	X	-	X	-	X
SIT	X	-	X	-	X
IST	X	-	X	-	At S/C level
SVT	SVT 0	-	-	-	-

X = test performed with:

Q= qualification level when relevant

"-" = no test

(*) = if relevant according test performed at unit level

= test part of the system qualification

Table 6.2.4-2: Herschel & Planck SVM – Test matrix

6.2.4.3 PLM Level- Summary

[H-EPLM] & [PPLM]

Test	Herschel			Planck		
	EQM	STM	FM	CQM	RFQM	PFM
Acoustic	-	-	-	Q	-	-
Alignments	-	X	X	X	X	X
Thermal Balance w/o Sun Simul.	-	Q	-	Q	-	-
He Leak test	X	X	X	X	-	-
Functional tests of instruments in Cryogenic env.	X	-	X	X	-	-
EMC R	X (*)	-	X	-	-	-
EMC CE	-	-	-	X	-	-
RF perfos.	-	-	-	-	X	-

X = test performed with:

Q= qualification level when relevant

"-" = no test

(*) with external source

= test part of the system qualification

Table 6.2.4-3: Herschel & Planck PLM – Test matrix

6.3 MODULE DEVELOPMENT MODELS

6.3.1 SVM development models

[H-SVM] & [P-SVM]

The SVM development will follow the same logic as the system one with following models:

- AVM for electrical and software validation. The PLM interfaces being very limited for this model, the system and SVM levels are only differentiated by the accommodation of instrument warm units.
- Herschel SVM STM for structural (Static Load Test) and thermal (balance) validation at SVM level and then mechanical qualification during Herschel Satellite STM level; these tests will provide SVM contractor with information for Planck SVM preliminary thermal validation and acoustic response.
- Planck SVM PFM fully thermal validated during advanced thermal test #1 at Planck Satellite level (refer to § 6.2.1) and then mechanical qualification at Planck Satellite PFM level.
- PFM submitted to electrical functional test, EMC tests and final software qualification.

Neither mechanical nor thermal tests are planned at SVM level for the flight models.

6.3.2 PLM development models

Herschel E-PLM

[H-EPLM]

Thank to ISO heritage the development of the Herschel E-PLM will use only two models:

- EQM which is the ISO QM cryostat modified to be a representative test set-up for the three scientific instruments, with these CQM of instrument FPU's, operated by the AVM of instrument warm electronics, according to [AD1-10] it will be used:
 - to demonstrate mechanical & thermal compatibility between the three instruments
 - for EMC test of instruments at operating temperature
 - to validate the alignment procedure between the HIFI-FPU and the HIFI-LOU

Design & Development Plan (DDP)

Doc. n° H-P-1-ASPI-PL-0009

Issue: 4 / Revision: 1

Date: 8/11/2004

Page 68/155

- For limited validation of the functional performances with the use of an “active cooled cover” at this stage
- PFM used in two different phases:
 - a qualification phase where the PFM cryostat is equipped with dummies of instrument FPU to be used on Herschel STM for mechanical and alignment qualification and on EPLM level alone for thermal pre-qualification,
 - a PFM phase with the integration of the FM instruments followed by integrated system test and functional test. The final thermal qualification and mechanical acceptance will be performed at system level.

Such a sequence is well adapted with the planning constraints of instruments, making CQM instruments available in time for refurbishment into flight spares and putting the need date of the FM instruments at the latest.

Planck PLM *[P-PLM]*

The development of the more complex and more critical PPLM will be based on four models:

- **RFDM** (Radio Frequency Development Model) to validate very early in the programme the computation and measurement methods of the radiated pattern and of the straylight rejection. This model will be a RF mock-up not fully representative of the exact geometry of Planck: it is based on the existing reflectors (from ARCHEOPS balloon borne experiment) mounted and adjusted on a dummy structure surrounded by a baffle with a shape identical to the real one.
- **RFQM** (Radio Frequency Qualification Model): used to qualify the telescope and the baffling system with regards to the straylight rejection and to characterise the main and secondary lobes. This model is necessary because a complete RF test is not feasible in cryogenic environment and because the instruments cannot be operated at ambient. At PFM level, only the test of the lower LFI channel (30GHz) is planned. The RFQM will be composed of the QM telescope with QM reflectors, QM baffle, QM third groove of cryo-structure and mock-up of instrument FPU's and with representative horns allowing RF measurements at ambient. It will
 - validate by measurement the optical and straylight mathematical models
 - determine by test the radio frequency performances

- establish and verify the coherence between the optical properties (WFE) measured at telescope level and the radio frequency properties.
- **CQM** (Cryogenic Qualification Model) equipped with available CQM instruments (HFI), coolers (limited to PACE for SCC) and without QM reflectors. This model will be used for pre-acoustic testing and then for functional qualification at cryogenic temperature and thermal qualification.
- **FM** (Flight Model) equipped with FM instruments and coolers and submitted to an ambient functional test prior to delivery at system level for spacecraft integration and complete testing.

6.4 TELESCOPE DEVELOPMENT MODELS

6.4.1 Herschel Telescope

[H-EPLM]

The Flight Model (FM) of the Herschel telescope will be delivered as Customer Furnished Equipment (CFE). FM will be mounted on the Herschel FM.

No other development model will be delivered by ESA. A Thermal Dummy (TD) and a Structural Model (SM) will be developed and procured by Herschel AIT contractor (Astrium) to be used during the Herschel STM test campaign.

6.4.2 Planck Telescope

[P-PLM]

The Planck Telescope shall be assembled then shall be fully qualified (QM) or acceptance tested (FM) including environment tests and optical performance verification in cryogenic environment prior to be delivered to PPLM. Two models will be manufactured:

- one Qualification Model (QM)
 - without Reflectors during “cryo-optical” measurement at cryogenic temperature (down to 100K) with video-grammetry method,
 - with dummy Reflectors during mechanical qualification, including pre-acoustic test at PPLM CQM level,
 - without any reflectors for PPLM CQM thermal and cryogenic sequence,
 - with QM reflectors for radio frequency performance characterisation with RFQM model.
- one Flight Model (FM)
 - with dummy Reflectors during mechanical acceptance tests (sine & acoustic); pending availability of QM reflectors, these tests could be performed with them to check overall stability,
 - with FM Reflectors during “cryo-optical” verification at cryogenic temperature,

Due to expected characteristics of the FM Reflectors (quilting specification not achieved), the previous reconstruction of WFE based upon Shack-Hartmann measurement principle (to be done in CSL Focal 5 with specific OGSE) is no longer valid. As Interferometry method does not work either, an alternative approach is proposed in Chapter 10: Annex Planck Telescope FM Verification Approach.

- with FM reflectors for satellite test campaign.

The implementation of some modifications after the subsystem or system qualification test phase (Planck RFQM/CQM) remains possible.

The QM reflectors of Planck shall be returned at the end of the PLM RFQM sequence to be refurbished into flight spares.

6.5 SUBSYSTEM DEVELOPMENT MODELS

6.5.1 Electrical Subsystems

[H-SVM] & [P-SVM]

The general approach is based on the fact that no electrical subsystem development model is required except for validation of the On Board Software and for some specific units. So the hardware development plan of electrical units will be defined in the paragraph dedicated to unit development models.

In order to clarify the electrical subsystem approach the following considerations are identified:

Avionics

The Avionics functional chain validation will be performed taking into account development at different levels. The validation process has to demonstrate both the functional and performances specifications.

At Subsystem level

- Herschel & Planck ACMS development and validation up to the delivery of the relevant ACMS Test Beds – or SCOE - (ACMS-TB)
- Common CDMS development and validation up to the readiness of CDMS-OBSW running on CDMU-EBB/EM

At AVM level:

- delivery of the CDMS-TB with EBB/EM units to the AVM
- delivery of the Herschel ACMS-TB with EBB/EM units to the AVM
- delivery of the Planck ACMS-TB with EBB/EM units to the AVM
- integration and validation of relevant AVM SVM Herschel and Planck configurations by changing the H/W and S/W configurations (typically 48 hours)
- integration of instruments warm units and validation of AVM Satellite in Herschel and Planck configurations.

At FM/PFM level:

- delivery of the Herschel and the Planck ACMS-TB's with FM units to the relevant PFM SVM
- delivery of both CDMS-TB's with FM units;
- integration and validation of Herschel and Planck PFM SVM;

Design & Development Plan (DDP)

Doc. n° H-P-1-ASPI-PL-0009

Issue: 4 / Revision: 1

Date: 8/11/2004

Page 72/155

- achievement of the Herschel and Planck PFM-TB's;
- integration of Payload Modules and validation of Herschel FM and Planck PFM.

The performance validation is performed in closed-loop on an ACMS simulator. This ACMS simulator consists in a fully simulated part for environment, dynamics, sensors and actuators modelling. The ACMS algorithms shall be fully representative, both functionally and numerically, of the On-Board Software. The Target processor shall be fully representative of the flight processor.

Star Tracker concerns at the same time an electrical and optical unit or groups of units, it could be reduced to the unit approach. Meanwhile this unit may require to be coupled with the ACMS for some compatibility and functional subsystem tests before being tested at system level.

RF and TT&C Subsystem

Antenna pattern and performance will be verified with test mock-ups of the two satellites at system level.

Power Subsystem

The Solar Array will be treated apart as it interfaces with the structure and the thermal control subsystems.

For other units identical for Herschel and Planck (i.e. PCDU and batteries) only one common unit (EM) will be developed for the AVM.

The qualification regarding the common Herschel/Planck environment will be achieved with one PCDU QM that will be used as flight spare.

The design of the selected Li-Ion battery is based on existing battery EQM currently undergoing qualification testing. This induces a minor design development program supporting a PFM approach for the common Herschel/Planck battery. The PFM model will undergo a full qualification test and will be used as flight model on Herschel (or Planck according SVM need in term of schedule). Two additional flight models are manufactured, one to be the flight model on Planck (or respectively Herschel) and the second to be the flight spare. These two models will undergo a full acceptance sequence.

In addition two STM for STM testing and an EM for AVM are manufactured. A key objective of this STM/EM program is to control and to reduce any residual risk to feed confidence into the detailed design of the flight models: PFM, FM and FS.

6.5.2 Mechanical Subsystems

SVM structure

[H-SVM] & [P-SVM]

In the frame of the Planck Satellite PFM approach and due to SVM commonality, for launcher compatibility, only a dedicated SVM Primary Structure shall be submitted to Static Load Test (SLT).

This test specimen is a H/P hybrid cone covering H/P criticality for both configurations and built from basic Planck cone SVM without the Planck reinforcement but with implementation of:

- Herschel H-PLM brackets (x12) to allow high loading on top of the cone, and verify H-PLM IF loads
- Herschel cone holes to verify high stressed area
- skins reinforcements to allow flux peaks reproduction at cone bottom

The SLT will combine the worst cases of Herschel and Planck configuration.

Two models, one STM and one FM will be manufactured for Herschel but only one PFM for Planck SVM. However the reuse on Herschel FM of some STM elements such as WU panels are envisaged with the following assumptions:

- the refurbishment into flight model shall be compatible with the overall schedule,
- the items to be refurbished shall be equipped with FM Hardware in term of Thermal control and Harness fixation,
- the implementation of some modifications after the system mechanical test phase (STM) remains possible.

The FM panels dedicated to the instruments units will be delivered in advance on the rest of the SVM to the PLM Contractors for instrument warm units integration.

Herschel Solar Array (Sunshield), Sunshade & associated structures *[H-EPLM]*

Two models of each item shall be supplied:

- one STM specifically adapted to the thermal test purposes, it will be used and qualified through mechanical and thermal qualification at Herschel STM level
- one Flight Model.

Panels of the Solar Array STM will be equipped with flight solar cells in critical areas. It will be submitted to a full qualification sequence before delivery to E-PLM integration.

Before delivery the Flight Model will be submitted to an acoustic test at acceptance level.

In addition, a "flasher" test is performed before delivery of the Flight Model as reference; this test will be repeated at system level to perform the trend analysis and to evaluate the performance degradation if any.

Prior to assembly, all PFM struts (one of each strut type) will be statically tested at qualification level.

Planck Solar Array [P-SVM]

In addition to the flight model used on Planck PFM Satellite, a STM will be manufactured. The STM built standard is:

- Structural panels fully flight representative,
- dummy cells, with a coating providing the alpha and epsilon of the flight cells and the final mass properties,
- three panel types (one from internal part, two from external part) partly covered (at least 5%) in critical areas by flight cells in addition to the above dummy cells

The mechanical qualification is achieved at subsystem level by the three STM panels partly covered by flight cells which will undergo complete mechanical test sequence at qualification level.

As, there is no thermal test planned at system level with SA PFM, the complete Solar Array thermal qualification is achieved on PFM at subsystem level. The complete Solar Array will be fully tested at ambient temperature and in thermal environment before delivery:

- three panel types (one from internal part, two from external part) will undergo thermal environment at qualification level,
- other panels will undergo thermal environment at acceptance level.

The thermal environment being the critical case for the Planck Solar Array, this last test also acts as workmanship verification.

Design & Development Plan (DDP)

Doc. n° H-P-1-ASPI-PL-0009

Issue: 4 / Revision: 1

Date: 8/11/2004

Page 75/155

Before delivery the Flight Model will be submitted to an acoustic test at acceptance level.

In addition, a "flasher" test is performed before delivery as reference; this test will be repeated at system level to perform the trend analysis and to evaluate the performance degradation if any.

At system level, the Planck SA FM will be used:

- for mechanical adjustment with Planck PFM Primary Structure
- for electrical continuity validation (flood test)
- for mechanical testing at satellite PFM level

At system level, the Planck SA STM will be used:

- for thermal/cryogenic testing at satellite PFM level with some modifications (additional holes) for AIT purpose and installation of heaters to simulate sun illumination.

Planck PLM Cryo-structure [P-PLM]

This subsystem includes the Main Baffle, the grooves and the truss interfacing the SVM.

Two identical models will be manufactured (CQM and FM), but the implementation of some modifications after the subsystem or PPLM qualification test phase (CQM/RFQM) remains possible.

This structure will be fully tested under mechanical and thermal environment at system level (qualification levels for CQM, acceptance for FM). The thermal performance is managed at system level. At subsystem level a minimum test qualification programme is required which covers:

- Characterisation of materials and coatings behaviour at operating temperatures and part qualification
- Mechanical qualification for the QM & acceptance for the FM

Herschel E-PLM support truss (interfacing SVM) [H-EPLM]

As for Planck, this support truss shall be considered as “primary structure”. So before integration on Satellite, test qualification programme will be developed on specific units taking into account mechanical and thermal loading.

The Flight Models will be acceptance tested at room temperature.

Thermal control [H/P]

Thanks to thermal de-coupling, the thermal control of each module is independent. For each of them, relevant thermal control subsystems will be manufactured according to model philosophy, but the implementation of some modifications after the system thermal test phase (Herschel STM, PPLM CQM and Planck thermal test #1) remains possible.

RCS [H-SVM] & [P-SVM]

The RCS will use qualified components so the development philosophy is as follow:

- One RCS “Herschel STM” comprising tanks, pipes & brackets, valves, pressure transducer and thrusters at STM standard. It will serve for Herschel STM mechanical and thermal test phases:
 - to qualify the new arrangement of the “off-the-shelf” RCS components
 - to provide the representativeness of the tank filling ratio (impact of the sloshing modes)
- One complete RCS FM will be manufactured for flight models for full validation and acceptance tests at all levels (equipment, module and satellite).

SVM Harness [H-SVM] & [P-SVM]

For Herschel STM SVM, a dummy harness will be provided for mechanical and thermal tests and integrated on the structure using flight standard workman ship. The harness will be mechanically qualified at this level.

The dummy harness consists of a mass representative of power and signal interfaces harness. A limited number of signal harness wires will be provided with crimp contacts

Design & Development Plan (DDP)

Doc. n° H-P-1-ASPI-PL-0009

Issue: 4 / Revision: 1

Date: 8/11/2004

Page 77/155

manufactured in flight standard but made from commercial parts to qualify the connections.

Dummy harness shall be mounted to the Herschel STM with flight representative brackets/fixations and shall give representative loads to the structure. It will be accommodated to fulfil the thermal test requirements (power supply of thermal dummies, temperature sensors...)

The complete FM harnesses will be installed on both **Flight Models**.

RF and TT&C Subsystem [H-SVM] & [P-SVM]

Some elements of this subsystem as LGA/MGA horns, wave-guides and RF cabling need to be qualified from mechanical and thermal point of view.

These elements are considered as mechanical parts and will be installed on the Herschel STM to be partly tested and qualified at system level, independently from the subsystem itself and without relation with the electronic units to which they are connected.

Three sets will be manufactured:

- one will be used on Herschel STM for mechanical and thermal qualification tests,
- two others will be installed on flight models.

The possibility to implement some modifications after the subsystem test or the system mechanical test (Herschel STM) phases remains possible.

6.6 UNITS DEVELOPMENT MODELS

[H/P]

6.6.1 Units Model Classification and Model philosophy

The unit model classification is defined as follows:

- *MTD (Mass & Thermal Dummy)* :

A MTD is only representative of the mechanical and thermal interfaces defined by relevant specification.

Providing successful and no over-stressing testing, structural parts of MTD can be used as for FM or flight spares.

- *EBB (Elegant Bread Board)* :

The EBB (or DM) is representative of the flight model in terms of conducted emissions and in-rush currents. Volume shall be representative as much as possible. It cannot survive thermal and vibration environment.

- *EM (Engineering Model)* :

The EM is fully equivalent in form fit and functions to the FM unit, including mechanical and thermal aspects. The EM EEE parts are not Hi-Rel, but from the same type and from the same manufacturer as the FM unit.

EM can be used as integration spare for functional test but not as flight spare.

- *EQM (Engineering & Qualification Model)* :

The EQM is an EM that is also devoted to partial qualification testing at equipment and subsystem level.

EQM can be used as integration spare but not as flight spare.

- *QM (Qualification Model)* :

The QM is built to FM standard with Hi-Rel parts and full quality assurance and configuration control. It is devoted to full qualification testing at equipment and subsystem level.

Providing successful and no over-stressing testing, QM can be used as FM or flight spares.

- *FM (Flight Model)* :

The flight model shall be of flight standard and shall be submitted to acceptance testing.

The unit or subsystem development plan shall be based on a realistic development approach taking into account the system development requirements on one side and the unit or subsystem development requirements on the other side.

Some units or subsystem are identically used on Planck and Herschel. In that case only one development or qualification unit is necessary and only one FS is requested.

The general unit procurement philosophy for the avionics shall be based primarily on the re-use of existing design or design with minor adaptation.

Furthermore, the number and the quality of unit development models is dependent on, the number of subsystem and system (AVM - STM – FM/PFM) development models previously identified and of the status of the development of the equipment.

From a technical point of view, the unit development plan shall satisfy several conditions:

- Verify the compliance of the design of each unit or subsystem with its specifications decreasing the development time and cost to the minimum.
- Achieve the full qualification as soon as possible.
- Guaranty the delivery of flight units or subsystems in due time to system AIT.

So the development approach strongly depends on the design itself and on the qualification status. From this point of view the units are split in four categories.

6.6.2 Existing and already qualified units (Category A)

The previous considerations are no more necessary as these “of the shelf” units are considered as fully qualified. In addition to Flight Models to be used on Satellite Flight Models, an additional Flight Model shall be delivered as Flight Spare (FS).

For system AVM purpose, an EM or EBB will be delivered.

6.6.3 Existing but not completely qualified units (Category B)

These "off the shelf" units have been already used and qualified on another programme, but a delta qualification is necessary as the mechanical, thermal, or EMC qualification level range is not fully compliant with Herschel/Planck requirements. The design validation being already achieved, the delta qualification will be performed on a first Qualification Model (QM) fully flight representative in order to be refurbished as Flight Spare (FS). The second model will be manufactured as FM.

For system AVM purpose, an EM or EBB will be delivered.

6.6.4 Existing units requiring minor modifications (Category C)

These "off the shelf" units have been already used and qualified on another programme, but minor modifications have to be implemented to be compliant with Herschel/Planck technical requirements. The design validation and possible corresponding delta qualification will be performed using the first Qualification Model (QM) fully flight representative in order to be refurbished as Flight Spare (FS). The second model will be manufactured as FM.

For system AVM purpose, an EM or EBB will be delivered.

6.6.5 Units of new design (Category D)

For this category it is necessary to verify very early in the programme that this new design is really compliant. This will be done by means of EBB or EM: non-flight units, without redundant chains, non Hi-Reel parts, with (EM) or without (EBB) physical representativeness.

Then the design qualification will be done by means of flight representative units using commercial or Mil. Grade parts (EQM) or Hi-Rel parts (QM) depending on the procurement and manufacturing duration. In any case the manufacturing process and procedures have to be identical to the ones used later for the flight articles.

In case of QM philosophy, this model will be reused as flight spare after refurbishment. In case of EQM philosophy, an additional flight model will be delivered as flight spare.

For system AVM purposes, pending on procurement and manufacturing duration, either the EM /EBB or EQM will be delivered.

6.6.6 Units – Model philosophy

Taking into account that for STM purposes, only MTD are necessary, the development approach, combined with the Satellites development plan, leads to the following models:

Cat.	AVM	STM Herschel	STIA Planck	FM Herschel	PFM Planck	Spare
A	EM	MTD1	-	FM1	FM2	FM3
B	EM	MTD1	-	FM1	FM2	QM refurb.
C	EM	MTD1	-	FM1	FM2	QM refurb.
D	EM or EQM	MTD1	-	FM1	FM2	QM refurb. (or FM3 in case of EQM philo)

Table 6.6.6: Units – Model Philosophy

6.7 MODEL PHILOSOPHY FOR SCIENTIFIC INSTRUMENTS

[H/P]

The following models of instruments (PACS, HIFI, SPIRE, LFI and HFI) will be delivered as Customer Furnished Equipment (CFE):

- AVionic Model (AVM)
- Cryogenic Qualification Model (CQM)
- ProtoFlight Model (PFM).

The instrument development is generally based on AVM of the warm units, simulator and CQM for coolers and FPU's and PFM for both.

These models will be used for integration and qualification at system level as indicated by the following Tables 6.7-1 & 6.7-2.

Pending model philosophy adopted by instruments, flight spares are the refurbishment of the above CQM or/and spare kits.

**Design & Development Plan
(DDP)**

Doc. n° H-P-1-ASPI-PL-0009

Issue: 4 / Revision: 1

Date: 8/11/2004

Page 82/155

ALCATEL will procure:

- the mass and thermal dummies (MTD) of the warm units to be used in the relevant SVM STM,
- the mass and thermal dummies (MTD) of the cold units to be used in the Planck PLM CQM,
- the Planck instrument RF mock-up used for Planck RF development models

EADS-astrium will procure:

- the mass and thermal dummies (MTD) of the cold units to be used in the Herschel E-PLM STM

The procurement will be based on instrument design and interface specifications.

Associated MGSE and EGSE will be provided by instrument as CFE.

- The instrument EGSE will be used throughout all Phases of the programme including instrument level tests; PLM tests, satellite tests and in-orbit operations.
- The test procedure developed for the Instrument level tests will be re-used during system tests in the system EGSE environment with no or minimal modifications.
- The instrument EGSE and the flight control system will be based upon SCOS-2000.

Herschel Satellites and Modules				
	AVM	PLM EQM	STM	FM
SPIRE				
Warm Units	DPU AVM	AVM	MTD (*)	PFM
FP Units	DRCU Simul.	CQM	MTD (*)	PFM
HIFI				
Warm Units	ICU AVM	CQM	MTD (*)	PFM
FP Units	loads	CQM	MTD (*)	PFM
PACS				
Warm Units	DPU AVM	AVM/BB	MTD (*)	PFM
FP Units	Simulator	CQM	MTD (*)	PFM

(*) MTD are not part of instrument delivery

TABLE 6.7-1 UTILISATION OF HERSCHEL INSTRUMENT MODELS AT SYSTEM LEVEL

		Planck Satellites		
		AVM	CQM	PFM
HFI				
Warm Units		CQM	CQM/MTD (*)	FM
FP Units		Simulator	STM/CQM	FM
4K Cooler		CQM & Simul.	CQM	FM
0.1 K Cooler		CQM & Simul.	CQM (PLM pipes only)	FM
LFI				
REBA		AVM/CQM loads	N/A	PFM
RAA			STM/MTD (*)	PFM
SCS				
PACE Nominal			MTD (*)	FM1
PACE Redundant		simulator	QM + GSE (*)	FM2
SCC N & R		N/A	N/A	FM1/FM2
SCE N & R		CQM & N/A	N/A	FM1/FM2

(*) not part of instrument delivery

TABLE 6.7-2 UTILISATION OF PLANCK INSTRUMENT MODELS AT SYSTEM LEVEL

Avionics Model (AVM)

According to AVM system test objectives as defined in §6.2.2, the instrument AVM units must have the following built standard:

- electronics flight standard except for parts. Commercial parts have to be of the same technology as FM parts
- software flight standard, software of flight quality must be able to be run
- form, fit and function of the flight model
- for Planck the AVM units used with the CQM shall be compatible of thermal vacuum environment in order to allow performing the cryogenic test.

In order to save cost the AVM reducing redundancy may reduce hardware contents:

- cold redundant units or channels may be deleted if no automatic switch-over is involved
- multiple redundancy of hot redundant units or modules may be reduced by electrical dummies (to e.g. dual redundancy) for AVM objectives
- simulators may be supplied for units not directly interfacing with the spacecraft subsystems. The level of these simulators, to be agreed with ESA, will allow verification of the correct execution of the flight procedures.

Qualification Models

Because of their new development status and/or the criticality of their performance to the flow of the AIV programme, specific units will deliver QM models for the assembly tests at payload module level.

These are:

- Herschel Focal Plane Units (SPIRE, PACS, HIFI including LOU)
- Planck Focal Plane Unit (HFI, LFI)
- Planck coolers (20K Sorption Cooler, 4K JT Cooler, 0.1K Dilution Cooler).

The qualification models standard will be the same as for flight models, cold redundant units (20K-sorption cooler) may be replaced by dummies, and the number of similar channels may be reduced.

Flight Model

The PFM test objectives is the qualification of spacecraft system by functional and environmental tests. The FM units therefore shall have full flight standard verified by formal functional and environmental acceptance tests.

6.8 SPARE PHILOSOPHY

[H-SVM] & [P-SVM]

In order not to interrupt the Satellite **Flight Models** AIT sequence, including the launch campaign, flight spares of all units belonging to the Herschel and Planck SVM will be provided according the following rules:

Structures

The experience shows that spares of structural elements are generally not necessary. However a minimum repair kit could be considered: elementary GFRP or CFRP rods, raw materials, adhesives...

Harness

No spare is proposed (excepted a limited number of spare connectors) because any damage can be easily repaired.

Thermal control

At least one heater of each type will be procured as spare.

For washers, fillers, straps, OSRs and paints a repair kit is sufficient.

MLIs can be repaired in case of accidental tear or STM/QM MLI could be used, but to not degrade cleanliness and performances a provision of pre-assembled MLI sheets is recommended.

At least one heat-pipe of each type will be procured as spare.

RCS

Most of the elements are standard items and thus the spares can be considered as part of the series effect at unit Manufacturer level. A limited number of spare parts for critical elements (thrusters...) will be supplied.

Planck Solar Array

No spare is proposed. The risk is limited to the damage of some cells or cover glasses. At the end of the test sequence after a detailed visual inspection the necessary exchange of damaged parts will be done, and the SA status verified by a flasher test. A repair kit is necessary including solar cells of the various current classes, OSRs, cables and connectors.

Electrical units

For electronic units, the spare model philosophy is presented in § 4.5 and summarised hereafter:

Cat.	Spare
A	Fully Flight Model
B	QM refurbished
C	QM refurbished
D	QM refurbished or Fully Flight Model if EQM philosophy

Antennae

For antennae, the spare philosophy is the same as the one for electronic units:

Cat.	Spare
A	Fully Flight Model
B	QM refurbished
C	QM refurbished
D	QM refurbished or Fully Flight Model if EQM philosophy

**Design & Development Plan
(DDP)**

Doc. n° H-P-1-ASPI-PL-0009

Issue: 4 / Revision: 1

Date: 8/11/2004

Page 87/155

6.9 MODEL PHILOSOPHY SUMMARY TABLES

	Herschel /Planck AVM	Herschel E-PLM EQM	Herschel Satellite		Spare
			STM	FM	
H-TELESCOPE	N/A	N/A	TD & SM	FM	N/A
H-EPLM					N/A
Cryostat	N/A	ISO QM	PFM	PFM	N/A
Sunshade	N/A	N/A	S(T)M	FM	N/A
Sunshield	N/A	N/A	S(T)M	FM	N/A
Interface truss	N/A	N/A	PFM	PFM	N/A
Exp. FPU's					
HIFI	Simulator	CQM	MTD	PFM	FS
SPIRE	DRCU Sim.	CQM	MTD	PFM	CQM refurb.
PACS.	Simulator	CQM	MTD	PFM	CQM refurb.
H-SVM					
Structure	N/A	N/A	H-STM	H-FM	Kit
Thermal Control	N/A	N/A	H-STM	H-FM	Kit
Harness	EM	N/A	H-STM	H-FM	Kit
RCS	N/A	N/A	H-STM	H-FM	Kit
ACMS					
Unit Cat A	EM	N/A	H-MTD	H-FM1	H-FM2
Unit Cat B	EM	N/A	H-MTD	H-FM	H-QM
Unit Cat C	EM	N/A	H-MTD	H-FM	H-QM
Unit Cat D	EM(EQM)	N/A	H-MTD	H-FM	H-QM (FM2)
CDMS					
Unit Cat A	EM	N/A	MTD1	FM1	FM3
Unit Cat B	EM	N/A	MTD1	FM1	QM refurb.
Unit Cat C	EM	N/A	MTD1	FM1	QM refurb.
Unit Cat D	EM(EQM)	N/A	MTD1	FM1	QM ref. (FM2)
Power supply S/S					
Unit Cat A	EM	N/A	MTD1	FM1	FM3
Unit Cat B	EM	N/A	MTD1	FM1	QM refurb.
Unit Cat C	EM	N/A	MTD1	FM1	QM refurb.
Unit Cat D	EM(EQM)	N/A	MTD1	FM1	QM ref. (FM2)
TT&C S/S					
Unit Cat A	EM	N/A	MTD1	FM1	FM3
Unit Cat B	EM	N/A	MTD1	FM1	QM refurb.
Unit Cat C	EM	N/A	MTD1	FM1	QM refurb.
Unit Cat D	EM(EQM)	N/A	MTD1	FM1	QM ref. (FM2)
Exp. warm units					
HIFI	AVM	AVM	MTD	PFM	Spare kits
SPIRE	CQM	CQM	MTD	PFM	Spare kits
PACS.	AVM	AVM	MTD	PFM	Spare kits

**TABLE 6.9-1 Herschel MODEL PHILOSOPHY
[H-SVM] & [H-EPLM]**

**Design & Development Plan
(DDP)**

Doc. n° H-P-1-ASPI-PL-0009

Issue: 4 / Revision: 1

Date: 8/11/2004

Page 88/155

	Herschel/ Planck AVM	Planck PLM CQM	Planck Satellite		Spare
			STM	PFM	
PPLM					N/A
Cryo-Structure	N/A	QM		FM	QM refurb.
Telescope	N/A	QM		FM	QM refurb.
Reflectors	N/A	Dummy QM on RFQM		FM	N/A
Exp. FPU's					
HFI	Simulator	STM/CQM		PFM	FS
LFI	Simulator	STM/MTD		PFM	TBD
P SVM					
Structure	N/A	Dummy		FM	Kit
Thermal Control	N/A	Dummy		FM	Kit
Harness	EM	Dummy		FM	Kit
RCS	N/A	N/A		FM	Kit
Solar Array	N/A	N/A		(STM) FM	Kit
ACMS					
Unit Cat A	EM	N/A		P-FM1	P-FM2
Unit Cat B	EM	N/A		P-FM	P-QM
Unit Cat C	EM	N/A		P-FM	P-QM
Unit Cat D	EM(EQM)	N/A		P-FM	P-QM (FM2)
CDMS					
Unit Cat A	EM	N/A		FM2	FM3
Unit Cat B	EM	N/A		FM2	QM refurb.
Unit Cat C	EM	N/A		FM2	QM refurb.
Unit Cat D	EM(EQM)	N/A		FM2	QM ref. (FM2)
Power supply S/S					
Unit Cat A	EM	N/A		FM2	FM3
Unit Cat B	EM	N/A		FM2	QM refurb.
Unit Cat C	EM	N/A		FM2	QM refurb.
Unit Cat D	EM(EQM)	N/A		FM2	QM ref. (FM2)
TT&C S/S					
Unit Cat A	EM	N/A		FM2	FM3
Unit Cat B	EM	N/A		FM2	QM refurb.
Unit Cat C	EM	N/A		FM2	QM refurb.
Unit Cat D	EM(EQM)	N/A		FM2	QM ref. (FM2)
Exp. warm units					
HFI	AVM	AVM		PFM	FS
LFI	AVM	N/A		PFM	Spare kits
SCS	N/A	PACE QM		FM/CQM refurb.	N/A

**TABLE 6.9-2 Planck MODEL PHILOSOPHY
[P-SVM] & [P-PLM]**

6.10 GROUND SUPPORT EQUIPMENT (GSE)

6.10.1 Mechanical Ground Support Equipment (MGSE)

[H/P]

The Mechanical Ground Support Equipment shall support the complete spacecraft verification program from unit to system level. The main functions of MGSE are:

- Handling and Integration
- Transport and Storage
- Testing Support
- RCS Operations
- Mechanical, Contamination and Chemical Cleanliness Protection

The Herschel/Planck SVM MGSE will be designed to the maximum commonality. Some MGSE designed to support the AIT tasks at SVM level will be used during the Integration and Testing activities at Satellite Levels. Furthermore some MGSE will be designed interchangeable to support also the integration of the H/P PLM in order to increase the flexibility of use to the maximum extent; relevant dedicated adapters will cover the different I/F requirements.

The design of MGSE of previous program will be used to the maximum extent in order to reduce the cost and the development phase.

The use of refurbished items from XMM/Integral/Rosetta Programs is considered.

6.10.2 Electrical Ground Support Equipment (EGSE)

[H/P]

In order to minimise the cost and the development phase, the EGSE are defined according the following guidelines:

- Commonality between Herschel/PLANCK EGSE to guarantee support of the following test configurations:
 - The Herschel/PLANCK AVM Integration and Functional test
 - Herschel E-PLM Test Activities
 - Planck PLM Test Activities
 - PFM Herschel SVM Test Activities
 - PFM PLANCK SVM Test Activities

Design & Development Plan (DDP)

Doc. n° H-P-1-ASPI-PL-0009

Issue: 4 / Revision: 1

Date: 8/11/2004

Page 90/155

- FM Herschel Satellite AIT, environmental testing and launch campaigns activities
- PFM Planck Satellite AIT, environmental testing and launch campaigns activities
- Reduce costs and simplify management
- Heritage from running programme. To reuse to the maximum extent existing suitable design (e.g. Rosetta, Mars Express...).
- Guarantee that new developments or porting/up-grades are baseline on low-cost and generally available platforms
- Use well established LAN I/F standards for the P/L EGSE's to be integrated with the Satellites' EGSE, again inheriting them from previous programs as above
- Common S/W (or part of) between CCS, SIS, SVF, ACMS SCOE & Instruments SCOE
- Procurement at SVM/Equipment level and re-use at upper level (SVM and Satellites)
- The hosting of the Satellite Data Base.
- The access via internet to external users (e.g. P/L scientists) of the archived data (WWW)

Thanks to the AVM, EGSE will be validated prior to be used at Satellite levels.

6.10.3 Optical Ground Support Equipment (OGSE)

[H-EPLM] & [P-PLM]

To a large extent standard products, which are available off the shelf or which already exist at ALCATEL and or at Herschel AIT Contractor (Astrium) will be used as OGSE.

[P-PLM]

For specific WFE measurement of Planck Telescope, a Sharck-Hartmann method will be used. The wave-front sensor at 10.6 μ m shall be developed.

6.10.4 Cryo Vacuum Support Equipment (CVSE)

[H-EPLM]

The CVSE is the mechanical non-flight equipment that supports the vacuum and cryogenic ground activities with the Herschel E-PLM. The CVSE shall:

- ensure that the function of the Herschel cryo/vacuum system in its intended environment is fully supported and carried out easily and safe.
- be able to cover the Herschel-He S/S requirements starting with the PLM integration and ends with the launch campaign of the FM Herschel Satellite.
- be used to perform all cryogenic and vacuum operations of the Herschel-He S/S on PLM and System level.

The CVSE will be designed and manufactured according the one already developed in the frame of ISO programme.

6.10.5 RF Suitcase

[H-SVM] & [P-SVM]

A common Herschel/Planck RF suitcase shall be developed for Ground Segment Compatibility Tests requirements (RF Compatibility Tests).

This suitcase shall simulate the RF uplinks and downlinks characteristics of the satellites and shall be delivered to the ground.

All constituents are borrowed to the AVM with the exception of the TM/TC I/F simulator (separate contract). They will be shipped back to the SVM contractor to allow completing the AVM EMC conducted tests and SIT at F1 frequency.

Then, the SVM Contractor shall refurbish the TTC transponder EQM to F2 frequency and send it back to the RF suitcase Contractor.

An acceptance test of the RF suitcase, using the TTC SCOE, TM/TC DFE and CDMU SCOE will be performed before delivery.

Note: F1 and F2 correspond to Herschel and Planck TTC frequencies without any order of precedence.

6.11 ON BOARD SOFTWARE (OBS) DEVELOPMENT

[H-SVM] & [P-SVM]

6.11.1 Introduction

The Herschel/Planck on-board software design, development and verification phase requires to be run independently of the hardware design and development. The on board software will be structured such that the modifications to any individual code module have a minimum impact on the other modules.

Dedicated Software test beds will be defined independently by each software developer. Prior to formal delivery, each software shall be proved to run on the Software Validation Facility (SVF) to guarantee the representativeness of ISV and further ground maintenance activities.

A standardised software development environment will be used for the CDMS and the ACMS software design and development. This will reduce the programme risk. The development environment will be duplicated in each development site (including the Independent software validation and software maintenance facility).

The standard development environment is the central part of the SVF. It comprises a standard processor type, standard development language, standard software developments tools and single development team per subsystem.

The on-board software will be developed according to the state-of-the-art rules for spacecraft software.

- Uses of a software design tool
- Use of high level of code, supplemented by small sections of code
- Consideration of testability and failure indication already during the design stages.
- Insurance of clearly designed module interfaces (principles of information hiding). This to simplify the mechanism supporting the patching of OBS in flight.
- Use of a set of test tools including:
 - Code analysis tools to ensure the compliance with the project coding standard and to quantify the code complexity, testability and maintainability in terms of suitable software metrics.
 - Standardised SVF, simulating the complete environment of the software (including Hardware) but allowing a more through testing, independent

from the hardware availability, but with a representative timing behaviour.

- Automation of test (to facilitate regression testing) and treatment of software packages plus related test environment as one configuration item (to facilitate the software maintenance).
- Application of ESA software engineering standard ESA ECSS-E-40 and ECSS Q-80 and conduction of formal reviews with the Prime contractor

6.11.2 Software Validation Facility (SVF)

All software produced will be verified by an independent software verification team different from the software supplier. A Software Validation Facility (SVF) will support the software verification.

The SVF typically comprises one or several target processor modules, software models of avionics hardware (e.g. communication bus) and simulations of the background environment.

The Herschel/Planck SVF Hardware will be used for different activities carried out by different users, according to the main phases of the Herschel/Planck AIT sequences. The same SVF will give the possibility to validate different On-Board Software, as CDMS SW, ACMS SW ... in a stand-alone configuration.

The necessity to run two or more On-board Software in parallel and synchronised to the same simulated real time has been considered and evaluated during phase B and has not been retained as baseline.

The SVF will be integrated with the Software Development Environment (SDE) and the Software Maintenance Facility (SMF) in order to provide a unified environment:

- for many of the different spacecraft's software's test activities without hardware in the loop;
- as target for the Independent Software Validation (ISV);
- for software maintenance at ESOC during the operational phase of Herschel and Planck.

6.11.3 Software Validation

The purpose of the software validation is the verification of the software conformity with the "On Board SW Design Requirement", Doc. H-P-1-ASPI-SP-0046.

The SW development and validation is arranged such that it can support all test activities. It has been required that each On Board Software product be designed to support partial deliveries, coherent with overall system test schedule. These Intermediate Software deliveries may become essential to reduce significantly program risks:

- Intermediate Software deliveries shall be clearly identified and introduced in the Software Development Plan.
- All On Board Software shall be designed to allow the intermediate deliveries of fully validated software versions.
- Intermediate Software deliveries shall be made to correct possible failures detected during system testing.

If made necessary to reduce the schedule risks, three OBSW issues are preliminarily identified, basically in line with the AVM integration needs

- Issue 00 = CDMS_SW Data TM/TC service, exchange protocol with I/F subsystems.
- Issue 01 = Issue 00 + modes management + spacecraft management: TM/TC plan management, thermal regulation, battery management, P/F and P/L monitoring). The ground/board interface (commandability and observability) and CDMS level FDIR are validated by these tests.
- Issue 02 = Issue 01 + Herschel or Planck ACMS_SW and ACMS_eqt_SW.

6.11.3.1 ACMS Software Validation

The ACMS_SW is validated according to the following phases:

- unit tests to ensure that the procedures and functions of the ACMS_SW are correct with respect to their functional description, and that the interfaces between its components behave correctly
- pre-validation by using a fully numerical computer simulator
- HW/SW integration are to check the correct interaction of the I/O software, the HW dependent SW and the real time core when running on the computer representative model (EBB)
- Validation phase is to verify the conformance of the complete ACMS_SW (the real one on a representative environment) with the ACMS_SW SRD and ICD

The ACMS_SW may be staggered in line with ACMS validation needs

6.11.3.2 CDMS-OBSW Validation

The CDMS_OBSW is validated according to the following phases:

- unit tests to ensure that the procedures and functions of the OBSW are correct with respect to their functional description
- HW/SW integration to check the correct interaction of the I/O software, the HW dependent SW and the real time core when running on the computer representative model (EBB)
- Validation phase is to verify the conformance of the complete CDMS_OBSW (the real one on a representative environment) with the OBSW SRD and ICD

6.11.4 Independent Software Validation (ISV)

The supplier and an Independent Software Validation (ISV) team different from the software supplier shall verify all produced software.

The objectives of the ISV tasks are to achieve an independent validation of the Herschel/Planck On Board Software. Except if re-used as is from a previous application, the following On Board Software shall be independently validated:

- Bootstrap Firmware
- CDMS Software (incl. Kernel & Mass Memory management Software)
- ACMS Software (incl. Kernal Software)
- Startracker Software

For this, a team, independent from the on-board software development contractor(s), shall perform reviews and tests of the Herschel / Planck On Board Software.

This validation shall use:

- the software specifications produced by the Prime, and the SVM contractor,
- the User Requirements Documents (URDs) produced by the Prime, the SVM contractor and possibly lower level contractors,
- the Software Requirements Documents (SRDs) produced by the software contractor(s),
- the Software Design Documents (ADDs and DDDs) produced by the software contractor(s),
- the code (source + executable) produced by the software contractor(s),
- and the Software Validation Facility (SVF).

The Independent Software Validation activities shall be performed on the Software Validation Facility in 2 main steps:

- First step on the "AVM" release, composed of the complete and integrated versions of the above software (Issue 02)
- Second step on the "Flight Models" release, composed of the same SW products at the time of the SVM FM integration

**Design & Development Plan
(DDP)**

Doc. n° H-P-1-ASPI-PL-0009

Issue: 4 / Revision: 1

Date: 8/11/2004

Page 97/155

During **Satellite Flight Models** AIT activities, SW changes (bugs, new requirements,...) on the "PFM/FM" release will go through the nominal validation process ("NCR" Review Board) at SW subcontractor, then possibly system level. In nominal, they will not individually go through an ISV run except if it is recommended by the conclusions of the "NCR" Review Board.

After the launch and until the end of the mission, the software maintenance and validation will be performed by ESOC.

7 DESIGN AND DEVELOPMENT FLOW

7.1 SYSTEM REVIEWS – DEFINITION

[H/P]

The basic development plan of Herschel/Planck is to provide a programme so built as to achieve a logical, sustainable schedule of events allowing an orderly design phase, comprehensive design qualification and soundly based manufacture and proto-qualification time scale.

The development plan and the schedule are set up against the technical development logic with the following main drivers:

- the selected model philosophy
- the end of Phase B being the real Phase C/D activities start up
- the launch date requirement for Herschel/Planck by mid February 2007

At appropriate steps during the progress of the Herschel/Planck programme, systems reviews will be held to monitor the status of the development and to approve the start of the next phase. The following systems reviews will be performed during the Herschel/Planck programme:

- **System Requirement Review (SRR)**

To be held early in Phase B, the SRR aims to establish

- Requirement baseline from system down to module and subsystem levels
- Interface definition down to subsystem level
- The product assurance requirements

– **Preliminary Design Review (PDR)**

To be held at the end of Phase B, the PDR will be the start of Phase C/D activities. The main objectives will be to verify the compliance of the system design with the requirement including the performances. The outputs will be

- The requirements specifications down to equipment level
- The preliminary definition documentation
- The design justification file
- The draft ICD's
- Hi-Rel parts procurement status (to be confirmed)
- LLI procurement status (to be confirmed)

– **Critical Design Review (CDR)**

To be held in the first part of the Phase C/D, the CDR aims

- To assess the design, the performance and the development status of the Herschel/Planck programme
- To present qualification test plans
- To issue the final ICD's
- To release the manufacturing of flight model hardware

– **Qualification Review (QR)**

At an appropriate time, the QR will be conducted on the basis

- of qualification reports
- of complete Design Justification files

– **Flight Acceptance Review (FAR)**

At the end of the qualification and acceptance programme, the FAR will

- Confirm the completion of the Phase C/D objectives
- Declare the readiness for shipment to the launch site

In addition, ALCATEL will support the agency during the two following system reviews

– **Flight Readiness Review (FRR)**

The aim of the FRR is to declare Herschel and Planck Satellites ready for launch and flight.

– **In-Orbit Commissioning Review (IOCR)**

Following the in-orbit commissioning (Phase E1), the IOCR will

- Pronounce the in-flight acceptance
- Authorise the entry into service
- Ensure feedback to the actors in the programme (lessons learnt)

7.2 CRITICAL AREAS AND DEVELOPMENT MILESTONES

7.2.1 Introduction

[H/P]

In support of the risk assessment developed in Chapter 3.3, major development milestones have been defined by ALCATEL considering the following elements:

- Driving performance requirements,
- Design implementation,
- Development plan and model philosophy,
- Programme schedule,
- Cost.

Complementary milestones are also defined in addition to the above major reviews.

These milestones correspond to the verification of a key performance in the development plan. Successful achievement of **such milestones will indicate a major step down in the risk assessment** for the rest of the programme.

**Design & Development Plan
(DDP)**

Doc. n° H-P-1-ASPI-PL-0009

Issue: 4 / Revision: 1

Date: 8/11/2004

Page 102/155

7.2.2 Planck PLM

[P-PLM]

Numbering	Milestone title	Item of risk	Comment
MS-PPLM-01	Telescope WFE	Optical performance demonstration at 50K	Provides indirect measurement of the optical performance and allows to refine the main lobe characteristics (gain, polarisation, ...)
MS-PPLM-02	RFQM measurement	SIN computation verification	Telescope + baffle radiation pattern at all possible frequencies (up to 500 GHz TBC)
MS-PPLM-03	Main baffle and groove 3 emissivity measurement	Thermal performance of the passive stage	Elementary material tests at 50K
MS-PPLM-04	CQM TV/TB test	Passive / active cooler chain performance verification in flight representative configuration	First verification of the complete chain leading to the achievement of 0.1K on the HFI bolometers

**Design & Development Plan
(DDP)**

Doc. n° H-P-1-ASPI-PL-0009

Issue: 4 / Revision: 1

Date: 8/11/2004

Page 103/155

7.2.3 Herschel E-PLM

[H-EPLM]

Numbering	Milestone title	Item of risk	Comment
MS-FPLM-01	FM He II tank acceptance	Tightness to superfluid Helium	Key planning issue.
MS-FPLM-02	Cryo-harness technology qualification	Mechanical behaviour at operating temperature	ISO experience + Herschel increase of connection number (ISO X 5)
MS-FPLM-03	Cryo-valves acceptance	Leakage / operation in cold conditions	ISO experience
MS-FPLM-04	MLI efficiency test	Accuracy of telescope & CVV temperature predictions	Elementary test
MS-FPLM-05	TV/TB test on PFM cryostat	Cryogenic lifetime verification in cold conditions	Allows correlation of thermal model with 2 points of CVV temperature
MS-FPLM-06	GaAs solar cells	Power budgets	Qualification in progress. Status available at CDR

**Design & Development Plan
(DDP)**

Doc. n° H-P-1-ASPI-PL-0009

Issue: 4 / Revision: 1

Date: 8/11/2004

Page 104/155

7.2.4 Planck spacecraft

[P-Sat]

Numbering	Milestone title	Item of risk	Comment
MS-PL-01	CQM TV/TB test completion	Refer to MS-PPLM-04	Done without SVM STM (refer to MS PL-02)
MS-PL-02	No STM	Verification of frequencies / loads / mechanical properties	Refer to risk analysis in [RD1]
MS-PL-03	AVM tests completion in Planck configuration	Validation of electrical interfaces	Minimises risks at PFM level

7.2.5 Herschel spacecraft

[H-Sat]

Numbering	Milestone title	Item of risk	Comment
MS-H-01	STM mechanical tests completion	Verification of frequencies / loads	Validation of assumptions for FPU, helium components, tanks, telescope and LOU
MS-H-02	FM TV/TB test completion	Telescope temperature	First test with a flight representative telescope.
MS-H-03	AVM tests completion in Herschel configuration	Validation of electrical interfaces	Minimise risks at FM level

7.2.6 Instruments

7.2.6.1 LFI

[P-Sat]

Numbering	Milestone title	Item of risk	Comment
MS-LFI-01	Wave guides manufacturing	According to RF and thermal design by Custom Microwave (US).	all elements must be ready for FM radiometer chain integration
MS-LFI-02	Phase switches	Problems in achieving performances of 100MHz phase switches	No longer in the design
MS-LFI-03	HEMT's	Sensitivity to ESD and humidity environment	

7.2.6.2 HFI

[P-Sat]

Numbering	Milestone title	Item of risk	Comment
MS-HFI-01	0.1K cooler DM delivery	Reaching 0.1K	Successfully tested in May 2004
MS-HFI-02	Multi-mode horn	Measurement of polarisation	Solved by polarisation sensitive Bolometer

7.2.6.3 Sorption cooler

[P-Sat]

Numbering	Milestone title	Item of risk	Comment
MS-SCC-01	EBB tests	Schedule	Tests performed in 03
MS-SCC-02	CQM delivery	CQM PPLM Schedule	Replaced by QM PACE & GSE

7.2.6.4 HIFI

[H-Sat]

Numbering	Milestone title	Item of risk	Comment
MS-HIFI-01	LOU delivery	LOU development	CQM delivered in January 2005
MS-HIFI-02	WBS delivery	WBS development	CQM delivered in January 2005

7.2.6.5 SPIRE

[H-Sat]

Numbering	Milestone title	Item of risk	Comment
MS-SPIRE-01	Cryo-mechanisms	FTS, ...	STM performance review but without FTS.

7.2.6.6 PACS

[H-Sat]

Numbering	Milestone title	Item of risk	Comment
MS-PACS-01	Cold Readout Electronics Development Cycle	If performances not reached, use alternative technology	Performances reached with baseline technology
MS-PACS-02	Cryo-mechanisms Schedule	Ball bearing Components developments	Elementary test in 2003/2004 QM test in July 04

7.2.7 Planck Reflectors

[P-PLM]

Numbering	Milestone title	Item of risk	Comment
MS-PR-01	QM delivery	Planck Development	Separated test sequences: - QM Telescope and CQM PPLM acoustic tests with dummies reflectors - CQM PPLM Cryo without reflectors - RFQM test with QM reflectors

**Design & Development Plan
(DDP)**

Doc. n° H-P-1-ASPI-PL-0009

Issue: 4 / Revision: 1

Date: 8/11/2004

Page 107/155

7.2.8 SVM

[H-SVM] & [P-SVM]

Numbering	Milestone title	Item of risk	Comment
MS-SVM-01	Planck SVM STM structure delivery	Planck PLM CQM schedule	No Planck STM and SVM replaced by a dummy during PPLM CQM tests.
MS-SVM-02	Software URD issue (CDMS, ACMS)	Avionics schedule	Avionics Consolidation Plan completed in April 2003
MS-SVM-03	Completion of ACMS tests on AVM	Validation of avionics (core + Herschel + Planck)	Further SVM AVM tests will follow

7.2.9 SVM Subsystems

[H-SVM] & [P-SVM]

Numbering	Milestone title	Item of risk	Comment
MS-SS-01	Static Loading Test	Structure qualification	Structure fully flight representative
MS-SS-02	AVM ACMS delivery	AVM schedule	Avionics Consolidation Plan completed in April 2003
MS-SS-03	AVM CDMS delivery	AVM schedule	Avionics Consolidation Plan completed in April 2003
MS-SS-04	GaAs solar cells	Power budgets	Qualification in progress. Status available at CDR
MS-SS-05	Heat pipes for Sorption Cooler radiator	Power density	Sorption Cooler performances

8 ASSEMBLY, INTEGRATION AND TESTS FLOW

8.1 GENERAL AIT FLOW

[H/P]

In general the sequences for spacecraft AIT are structured in four distinct phases:

- the first phase includes the **mechanical/electrical integration and unit function tests**. In order to have a well-proven spacecraft a reduced SIT will be performed at SVM level prior to the mating with PLM.
- following the system integration phase all functions of the spacecraft will be tested. For this purpose a full **Integrated Satellite Test (IST)** under ambient conditions will be performed. During this IST the spacecraft will be operated in defined mission modes operated fully automatically from the central checkout system. The functional test programme will be completed by specific performance tests required by the scientific payload.
- With the end of the functional test phase under ambient conditions the **environmental test programme** will start. For the **Satellite Flight Models** the following test facilities are needed:
 - acoustic noise
 - sine vibration
 - thermal vacuum
 - cryogenic environment for Planck PLM
 - EMC
 - mass properties determination
 - compact antenna test range for RF ambient test of Planck.

Each major environmental test includes the following sub-activities:

set-up and check of set-up

Short Functional Test (SFT)

alignment verification prior and post environmental load

**Design & Development Plan
(DDP)**

Doc. n° H-P-1-ASPI-PL-0009

Issue: 4 / Revision: 1

Date: 8/11/2004

Page 109/155

specialised system functional test in the specific environment

dismounting and transportation to next test set-up.

- Full **ground segment compatibility test** under flight operational conditions

The Satellite Database (HPSDB) validation will be performed following a bottom up approach starting from the integration of the Avionics units up to the system IST through the SIT, IST/IMT performed at subsystem and modules levels.

8.2 TEST FACILITIES

[H/P]

Herschel and Planck will follow similar but independent AIT sequences in separate facilities.

As far as possible the environmental test programme will run at one test location, thus limiting transport and set-up activities to a minimum, except for Planck which requires a specific cryogenic facility only available in Liège (CSL).

The facility evaluation has been performed considering:

- the overall size of various modules
- the overall size of satellites
- the ability of the facility to fulfil the aims of the test
- the use of existing ones

The following European Co-ordinated test facilities have been considered:

- ETS
- IABG
- INTESPACE
- CSL

and

- ALCATEL Cannes

The baseline (under-lined when option) is presented in Table 8.2. Details and final choice will be reflected in relevant AIT Plans.

**Design & Development Plan
(DDP)**

Doc. n° H-P-1-ASPI-PL-0009
 Issue: 4 / Revision: 1
 Date: 8/11/2004
 Page 111/155

Activity	SVM	Herschel EPLM	Herschel Satellite	Planck PLM	Planck Satellite
AIT Sequence	Alenia premises	Astrium premises	Astrium premises	ALCATEL premises	ALCATEL premises
AVM sequence	Alenia premises		Alenia premises		Alenia premises
SVM/PLM mating			STM = ETS FM = Astrium Premises or ETS	ALCATEL Premises (with SVM dummy)	ALCATEL premises
Thermal / Cryogenic Environment	ETS	ETS	ETS	CSL	CSL
Static load Test	Primary Structure Contractor premises				
Mechanical Environment			ETS	ALCATEL premises (Acoustic)	ALCATEL premises
EMC		(on EQM)			
Cond.	Alenia premises		Astrium premises or ETS		ALCATEL
Rad.	N/A	Astrium premises	ETS		premises
Mass Properties	ETS		ETS		ALCATEL premises
Radio Frequency				RFDM : ALCATEL premises RFQM : ALCATEL premises	ALCATEL premises

Table 8.2: Baseline for facilities

8.3 SATELLITE AIT FLOW

8.3.1 Herschel STM AIT flow

[H-Sat] & [H-EPLM]

The structural qualification of the Herschel E-PLM will be done in cold conditions on satellite level after integration of the SVM SM.

After integration/test of the SVM (refer to §8.5.1) and of the E-PLM (refer to §8.6.2.1) by the relevant Contractor, the nominal AIT sequence of the Herschel STM Satellite shall content at least the following steps. This list does not reflect any sequence, the H-SAT contractor shall optimise the sequence and the logical flow shall be depicted in the relevant AIT Plan.

- SVM/E-PLM mating
- integration of Sunshield/Solar Array (HSS)
- integration of the Telescope
- alignment checks at appropriate steps
- RCS filling and pressurisation
- sine vibration
- acoustic noise test
- shock test and ARIANE 5 adapter fit check
- Micro-vibration characterisation
- mass measurement,
- COG and Mol determination in dry configuration
- RCS leak test
- RCS draining & drying
- SVM/PLM demating
- depletion & warm up
- disintegration.

The cryostat is cooled in He I during all the test sequence.

8.3.2 Herschel FM AIT flow

[H-Sat] & [H-EPLM]

After integration/test of the SVM (refer to §8.5.2) and of the E-PLM (refer to §8.6.2.2) by the relevant Contractors, the nominal AIT sequence of the Herschel FM Satellite shall content at least the following steps. This list does not reflect any sequence, the H-SAT contractor shall optimise the sequence and the logical flow shall be depicted in the relevant AIT Plan.

- SVM/PLM mating & integration tests
- Sunshield/Solar Array (HSS) integration
- Telescope integration
- system integration tests
- integrated satellite test (IST1)
- alignment checks at appropriate steps
- SFT at appropriate steps
- He II production and top-up when relevant
- Conversion to He I when relevant
- RCS filling and pressurisation
- acoustic noise test
- sine vibration tests
- Ariane 5 Adapter Mechanical & Electrical Fit-checks
- micro-vibrations characterisation
- thermal tests
- EMC testing
- mass and in plane CoG measurement
- final integrated satellite test (IST2)
- SVT1 and SVT2

The cryostat will be delivered to the system AIT cooled in He I; it will be kept in He I all along the FM AIT sequence including the transportation to the launch site and the launch preparation phase. The only exception concern the EMC and thermal tests performed with the cryostat in He II condition.

8.3.3 Planck PLM CQM/RFQM AIT flow

[P-Sat] & [P-PLM]

After integration of the PPLM (refer to §8.7), the nominal AIT sequence of the Planck PLM CQM/RFQM shall content at least the following steps. This list does not reflect any sequence, the P-SAT contractor shall optimise the sequence and the logical flow shall be depicted in the relevant AIT Plan.

- SVM dummy/PPLM mating
- alignment check
- Instrument functional test at ambient (integrated PLM test) at appropriate step
- acoustic noise test
- preparation for thermal/cryogenic test
- thermal balance test and cryogenic test including EMC C (cold)
- alignment check at appropriate step
- SVM dummy /PPLM de-mating
- PPLM RFQM integration
- RF testing

8.3.4 Planck PFM AIT flow

[P-Sat] & [P-PLM]

After integration/test of the SVM (refer to §8.5.2) and of the PPLM (refer to §8.7) by the relevant Contractors, nominal AIT sequence of the Planck PFM Satellite shall content at least the following steps. This list does not reflect any sequence, the P-SAT contractor shall optimise the sequence and the logical flow shall be depicted in the relevant AIT Plan.

- SVM/PPLM mating & integration tests
- thermal control & Solar Array integration
- reference Integrated Satellite Test (IST1)
- EMC tests (ambient)
- RF ambient test of the LFI
- sine vibration and acoustic tests
- Ariane 5 Adapter Mechanical & Electrical Fit-checks followed by Clamp-band release and drop test
- SFT at appropriate steps
- alignment check at appropriate steps
- thermal vacuum/thermal balance/cryogenic tests in CSL

As the redundant chain of the Sorption Cooler System are not verified during the PLM CQM sequence (previous baseline), both SCC, nominal and redundant, shall have to be verified during the PFM sequence thus imposing two cool down sequences:

The first one (step #1), to be performed early in the PFM flow, is dedicated to the functionality check of the SCC Redundant; in parallel, peculiarities of the Planck SVM Thermal Control will be validated,

The second one (step #2) at the end of the PFM flow is dedicated to the full functionality test of the complete cryogenic chain with the SCC Nominal.

- COG/MOI determination
- balancing
- final integrated satellite test (IST2)
- SVT1 and SVT2

8.4 AVM AIT FLOW

Common Herschel & Planck AVM activities ***[H-SVM] & [P-SVM]***

The AVM test sequence will be organised in order to optimise the schedule maximising the Herschel/Planck common verifications based on the design commonalties.

As the AVM instruments (Warm Units) will be used to manage the CQM instruments (Focal Plane Units) mounted on the relevant PLM CQM, the AVM system test will be performed at the completion of the PLM CQM test sequences.

The nominal AIT sequence of the AVM shall content at least the following steps. This list does not reflect any sequence, the SVM contractor shall optimise the sequence and the logical flow shall be depicted in the relevant AIT Plan.

- EGSEs validation
- AVM supporting benches reception
- Herschel/Planck Common Sub-systems I&T and UFT
- Herschel/Planck Common Sub-systems SIT
- Herschel Specific Sub-systems I&T and UFT
- Herschel Specific Sub-systems SIT
- Herschel Instrument Warm Units I&T
- Herschel EMC Conducted Tests
- Herschel SVM IST
- Planck Specific Sub-systems I&T and UFT
- Planck Specific Sub-systems SIT
- Planck Instrument Warm Units I&T
- Planck EMC Conducted Tests
- Planck SVM IST

The Herschel and Planck instruments warm units will be integrated into the AVM model to verify the communication and functional compatibility with the Avionics units in particular checking the 1553B bus communication with the CDMS and the power compatibility with the PCDU (e.g. LC L-power lines)

Specific Herschel or Planck AVM activities

[H/P]

The nominal AIT sequence of the AVM shall include, at the end of the "SVM Configuration" test campaign, slots for complements of IST at Satellite level.

This test will be performed under the responsibility of the relevant Satellite AIT team.

During these slots, the SVM Contractor shall provide all necessary access, logistics support and bench operators to perform the test as well as the overall support for the SVM part of the test

SVT-0

[H/P]

The SVT-0 will be performed on AVM at the end of the AVM campaign. This test will be performed via a NDIU or similar interface to the MOC via communication network connection (e.g. ISDN link).

8.5 SVM AIT FLOW

8.5.1 Herschel SVM STM AIT flow

[H-SVM]

The nominal AIT sequence of Herschel SVM STM shall content at least the steps listed here-after. This list does not reflect any sequence, the SVM contractor shall optimise the sequence and the logical flow shall be depicted in the relevant AIT Plan.

- Static test (performed at Primary Structure Level)
- STM Structure reception
- RCS STM integration
- RCS Thermal Control integration
- Thermal Control integration on panels and on central structure
- Harness dummy integration on panels and on central structure
- SVM MTDs integration
- Instruments WU MTDs, including WIH dummy, integration
- SIH dummy integration
- RCS proof and leak test at appropriate steps
- Preliminary instrumentation for TV/TB test in case of later accessibility limitation
- Final assembly including MLI integration and closure
- Instrumentation finalisation for TV/TB test
- Dummy Sunshield integration (TB/TV test purpose)
- Thermal Balance test with Sun simulation
- Alignment reference and check at appropriate steps
- Mass properties measurement
- Transport and delivery to relevant Satellite integration facility

8.5.2 SVM FM AIT flow

[H-SVM] & [P-SVM]

The Herschel/Planck SVM FM AIT sequence will be common as much as possible in order to maximise the commonality on the verifications of the two FM SVMs.

The verification of the common part of the two service modules will be performed using the same test sequence in order to reduce debug-time and schedule.

The specific Herschel or Planck part will be verified performing dedicated test sequence based to the AVM test campaign and to tests performed at unit/subsystem level.

The mission timeline and the OBCPs will be verified on the frame of the SITs and IST.

The nominal AIT sequence of both Flight Models shall content at least the steps listed here-after. This list does not reflect any sequence, the SVM contractor shall optimise the sequence and the logical flow shall be depicted in the relevant AIT Plan.

Remark : the baseline approach is a two-batch delivery for both SVMs:

Batch #1 : Instruments panels fully equipped

Batch #2 : complete SVM w/o WU panels

Common Herschel & Planck activities

- EGSEs validation
- Structure reception
- RCS integration
- Thermal Control integration on RCS
- Thermal Control integration on instrument panels
- Harness integration on instrument panels (SVM Harness + WIH supports & brackets)
- Transport and delivery of instrument panels fully equipped (Batch #1) to relevant Satellite integration facility
- Thermal Control integration on "servitude panels" (RF panel and Power/CDMS panel)
- Harness integration on servitude panels (SVM Harness)
- Thermal Control integration on central structure

**Design & Development Plan
(DDP)**

Doc. n° H-P-1-ASPI-PL-0009

Issue: 4 / Revision: 1

Date: 8/11/2004

Page 120/155

- Harness integration on central structure
- Sub-systems I&T and UFTs
- Sub-systems SITs
- RCS proof and leak test at appropriate steps
- Final assembly including MLI integration and closure
- Alignment reference
- Participation to Satellite IST1 in relevant Satellite integration facility
- Transport and delivery of SVM FM batch #2 (with EGSEs) to relevant Satellite integration facility

Herschel Specific activities to be performed before deliver

- SVM EMC Conducted Tests
- SVM IST

Planck Specific activities to be performed at satellite level

- Solar Array mechanical and electrical fit check (flood test)
- Solar Array flasher test
- Combined IST1

8.6 H-EPLM AIT FLOW

[H-EPLM]

8.6.1 Herschel PLM EQM AIT flow

The ISO QM cryostat is used for the electrical and functional testing of the scientific instruments in a representative in-flight environment. It has been modified in order to get a "Herschel" representative test set-up from instrument point of view and the modified ISO cryostat is called Herschel EQM cryostat.

The cryo harness of the PLM EQM will be Herschel flight representative in order to perform a realistic EMC test.

The integration of the EQM cryostat will take place in a clean room Class 100 environment. The integration of the external elements (except LOU to be done in class 100) and external harness will take place in a clean room Class 100.000 environment.

The Cryo-SCOE will substitute the Cryostat Control Unit (CCU).

The instrument warm units (WU) are needed during the PLM EQM test sequence and are accommodated inside a SVM dummy located at the base of the cryostat at a distance allowing a harness layout similar to the flight one.

The electrical and functional verification will then be performed in an integrated module test (IMT) and EMC test. Both tests need to be done in flight representative thermal environment, which means that the cryostat must be filled with liquid Helium and super fluid Helium has to be produced.

During the timeframe due to delay in the delivery of CQM instruments, some advanced tasks are performed. This approach provides more confidence with regard to the behaviour of the cryostat and a validation of cryogenic operations. So, *the nominal AIT sequence of the Herschel EPLM-EQM cryostat shall content at least the following steps.*

This list does not reflect any sequence, the H-EPLM contractor shall optimise the sequence and the logical flow shall be depicted in the relevant AIT Plan.

So, the EQM activities are split in two main steps.

Step #1:

- ISO PLM QM de-integration (upper & lower part, He I tank)
- modification of the ISO QM upper part to Herschel standard
- integration of the inner harness(CCH) except OBA CCH, OBA bypass
- closing of the cryostat.

Design & Development Plan (DDP)

Doc. n° H-P-1-ASPI-PL-0009

Issue: 4 / Revision: 1

Date: 8/11/2004

Page 122/155

- evacuation and leak test
- cool-down and filling (in clean room 100 000)
- cold leak test
- He II production
- He S/S performance
- depletion and warm-up
- opening of cryostat upper part (in clean room 100)= end of step #1

Step #2

- integration of the OB onto cryostat
- integration of the CQM instruments onto OB
- CCH finalisation
- SIH integration
- closing of the cryostat.
- evacuation and leak test
- cool-down and filling (in clean room 100 000)
- mating of pre-integrated SVM dummy equipped with CQM WU instruments
- He II production and Top-up
- Performance of instrument testing (IMT and EMC)
- alignment at appropriate steps
- depletion and warm-up
- opening of cryostat upper part (in clean room 100)= end of step #2

8.6.2 Herschel E-PLM PFM AIT FLOW

The Herschel E-PLM PFM AIT flow is divided into two phases:

- the qualification phase of the Herschel cryostat with the E-PLM PFM part of the qualification test phase of Herschel Satellite STM
- the workmanship verification, electrical and functional verification after integration of the PFM focal plane units during an acceptance test prior to delivery to Herschel Satellite PFM.

8.6.2.1 Herschel E-PLM PFM qualification phase

The qualification test phase of the Herschel E-PLM PFM serves to verify that the Herschel Cryostat, Sunshield, Sunshade meets the mechanical requirements with tests to be done at Satellite STM level (refer to §8.3.1).

A TB/TV test on E-PLM with specific GSE (e.g. “anti-radiator”) allows verifying the cryogenic lifetime performance in nearly orbital condition, taking into account contributors including the cryostat external isolation (refer to §6.2.1).

This test phase comprises the complete integration of the Herschel cryostat including the Helium S/S, the insulation S/S, the optical bench and the cryo-harness. The instrument FPU’s are represented by MTD.

The integration of the Herschel PFM cryostat will take place in a clean room Class 100 environment.

The nominal AIT sequence of the Herschel E-PLM for the qualification phase shall content at least the following steps. This list does not reflect any sequence, the H-EPLM contractor shall optimise the sequence and the logical flow shall be depicted in the relevant AIT Plan.

- assembly He II tank, cylindrical shielding and CVV
- integration inner harness
- assembly He I tank, tubing
- MLI integration
- closing cryostat lower part
- integration optical bench and integration FPU MTD onto OB
- integration OB & inner harness

Design & Development Plan (DDP)

Doc. n° H-P-1-ASPI-PL-0009

Issue: 4 / Revision: 1

Date: 8/11/2004

Page 124/155

- MLI closure
- closing of cryostat upper part
- integration of the external elements as LOU
- evacuation & leak test ⇒ transport to clean room Class 100.000.

Note: the envisaged low-level sine vibration test at ambient temperature (to provide first information on the cryostat modal characteristics and to verify the workmanship) is cancelled.

- cool-down and filling
- integration of thermal test adaptor replacing the SVM
- Integration of Telescope TD and HSS STM
- He II production and top-up
- ground lifetime test (limited test)
- He II top-up
- launch autonomy verification
- launch simulation (rapid depletion, vent-line evacuation and launch transient)
- H-EPLM thermal vacuum/balance test

The qualification test phase will be completed after mechanical testing at Satellite level with the depletion and warm-up of the cryostat. The upper part of the cryostat will be opened in clean room Class 100 environment and the MTD of the FPU's will be removed.

During this phase, when the cryostat is in flight representative environment and the instrumentation is in the expected temperature range (i.e. during He II production and top-up), the cryostat control electronic (CCU) interfaces can be verified.

8.6.2.2 Herschel E-PLM PFM acceptance phase

The acceptance test phase of the Herschel E-PLM PFM serves to verify that the PFM instruments are properly integrated and that the Herschel E-PLM - together with the instruments - meets the electrical and functional requirements. The structural and thermal acceptance tests will be performed within the environmental tests at satellite level.

This test phase comprises the integration of PFM FPU's into the Herschel cryostat and the integration of the warm instrument units on the relevant FM instrument panels fixed to the SVM STM as long as the SVM FM is not available.

The integration of the FPU PFM into the cryostat will take place in a clean room Class 100 environment.

The nominal AIT sequence of the Herschel E-PLM for the acceptance phase shall contain at least the following steps.

This list does not reflect any sequence, the H-EPLM contractor shall optimise the sequence and the logical flow shall be depicted in the relevant AIT Plan.

- integration of the FPU PFM onto OB
- completion of the inner harness
- closing of cryostat upper part
- integration of external elements as LOU
- evacuation & leak test ⇒ transport to clean room Class 100.000.
- He II production and top-up
- Integrated Module Test including instruments operational programme
- EMC CE test
- conversion to He I.

The Herschel E-PLM PFM will be delivered to Satellite AIT in He I conditions.

8.7 PLANCK PLM AIT FLOW

[P-PLM]

The two models of PPLM, the RF/CQM and the PFM, have to be integrated following the same general sequence. AIT activities are mainly dedicated to mechanical and electrical integration, the environmental test programme being performed at system level.

The nominal AIT sequence of the Planck PLM shall content at least the following steps. This list does not reflect any sequence, the P-SAT contractor shall optimise the sequence and the logical flow shall be depicted in the relevant AIT Plan.

- assembly of sorption coolers on SVM panels, the piping and cold ends are supported by a dedicated MGSE
- mounting of the 2 first grooves (central part) on the PPLM platform supported by MGSE
- assembly of GFRP struts and fixation of grooves.
- Assembly of the third groove (central part)
- mounting of the LFI RAA (including HFI FPU) on the PPLM platform. The RAA is supported by its MGSE
- mounting of the telescope on the intermediate structure
- fixation of the FPA on the telescope structure, adjustment of the interface shim under the BEU
- removing of the supporting MGSE of LFI RAA
- integration of warm units on dedicated SVM panels
- harness and piping connections
- thermal anchoring of pipes, wave guides and harness
- closure of integration apertures of grooves and assembly of external petals of grooves
- integration of the main baffle
- Integrated Module Test (IMT)
- leak test of cooler gas circuit at ambient temperature

**Design & Development Plan
(DDP)**

Doc. n° H-P-1-ASPI-PL-0009

Issue: 4 / Revision: 1

Date: 8/11/2004

Page 127/155

The PPLM will be integrated in clean room of Class 100000 with protective covers on sensitive areas. Special attention shall be put on the cleanliness requirements during assembling and connection of cryo-cooler piping.

The telescope is assumed to be aligned at lower level. The focal plane assembly alignment will be obtained by the mechanical mounting, the alignment versus telescope will be controlled with theodolites.

9 VERIFICATION PLAN

[H/P]

9.1 OVERALL LOGIC

The satellite design and development shall be verified against the System Requirement Specification [AD1-1] and shall be governed by the Verification Programme or Control Plan (VPP/VCP).

The VPP/VCP governs all verification activities at unit, subsystem, module and system levels. For each precise and identified requirement, referenced to the document it stems from, the proposed methods and levels of verification will be indicated.

The VPP/VCP will be completed by Verification Control Documents (VCD) applicable to each level of verification.

This chapter gives the main rules to be used to establish the VPP/VCP and the VCD; they are based on the ECSS-E-10-02A.

The logic and the links between all documents are illustrated by the figure 1 (page 8).

9.2 RESPONSIBILITIES

Within the Herschel/Planck verification programme, the responsibilities for all programme levels from system level down to unit level are allocated to the dedicated programme Contractors as follows:

- the system level responsibility is with the Prime Contractor ALCATEL. This system level responsibility has to perform the verification of the complete Herschel/Planck system versus the Agency (ESA)
- the module or subsystem level responsibility (mainly PLMs and SVMs), is with this level corresponding to the Major Subcontractors. It has to assure full verification of his module/subsystem versus the Prime Contractor ALCATEL
- the unit or subsystem level responsibility is with this level corresponding to the Subcontractor. It has to assure full verification of his unit or subsystem versus the Major Subcontractor.

The system verification effort is an overall system responsibility, conducted by engineering, AIV and PA organisations as follows.

Test Requirements will be issued by the engineering team at least for the main tests resulting from an analysis of specification requirements, calculation and mathematical modelling such as:

- physical measurements
- alignments
- vibrations
- acoustic noise
- separation shock
- thermal vacuum/thermal balance
- EMC
- cryogenic functional tests.

Integration and test procedures are issued by AIT team, from integration and test specifications if applicable, verified by engineering and approved by AIV and PA.

Integration and test reports are issued by AIT team, certified by the AIT Manager, agreed by PA and approved by AIV.

Inspection procedures are issued by Quality Control, from inspection specifications when applicable, verified by engineering and approved by PA.

Inspection reports are established by QA and approved by PA.

Evaluation reports (from integration, test, inspection reports and Request for Material Review) are established by the cognisant engineering responsible, verified by System Technical Manager and approved by AIV and PA.

9.3 VERIFICATION PROGRAMME PHASING

According to the process described here above, three major phases may be defined each of them being concluded by a specific issue of the verification matrixes:

a. Requirements identification

This 1st phase of the verification task will be to extract from the system specifications all requirements which have to be verified and to list them in the corresponding area of the verification matrix (refer to chapter 9.5.7). This phase takes place during the design phase and shall be concluded when all specifications are approved by a draft issue of the VPP available for the Preliminary Design Review (PDR).

b. Verification methods and level selection

This phase consists in finalising for each requirement, the most appropriate verification method(s) selected amongst those described after, with support of subsystems and scientific instruments verification plans when applicable.

This second run takes place during the development and shall be concluded at the Critical Design Review (CDR) by the final issue of VPP.

c. Verification process and control

This final phase takes place all along the development and AIT sequences, and shall be concluded at the Flight Acceptance Review (FAR) by a final edition of the VCD. Each requirement fulfilment will be indicated by the reference of demonstration document such as technical note, test report, test evaluation report, analysis report, design report or inspection report.

Approved waivers and non-conformance documentation will be addressed when applicable.

9.4 ENGINEERING DATA BASE

The Engineering database is an element of prime importance to be involved in the satellite development. The verification process will be supported by an Engineering database that allows:

- systematic traceability of all requirements at each verification level ;
- the possibility to perform coherence checks between products and levels ;
- monitoring of the verification process throughout the project life cycle ;
- identification of impacts at the various levels in case of change of requirements or criticality during lower level verification ;
- immediate and flexible reporting of data in support of the preparation of the project verification documentation ;
- minimisation of repetitive tasks ;
- elimination of errors ;
- integration into the higher level of the lower level verification data.

9.5 VERIFICATION PROGRAMME/CONTROL PLAN (VPP/VCP)

The Herschel/Planck VPP or VCP shall ensure a homogeneous approach to demonstrate design and development qualification and acceptance from unit level up to satellite level, covering all aspects of flight hardware and software as well as mechanical and electrical ground support equipment. For that,

- It determines the required analysis, the models to be tested and the test activities with associated tools and facilities as well as the rationale of the logical sequence of verification necessary to demonstrate that the Herschel and Planck satellites fulfil the performance, interfaces, safety and operational requirements of the envisaged missions.
- It provides a system wide visibility on compliance of hardware and software with the requirements and optimises the use of ground support equipment and test facilities.
- It defines the strategy implemented to guaranty the fulfilment of mission requirements and to control and minimise the risks at specification level, at definition level and at realisation level.

It is built from the following considerations:

- the VPP is aimed at demonstrating the capability of the satellite to fulfil the mission requirements
- the VPP has to be considered globally from unit to system levels, hence the verification task is a continuous and coherent process starting from the design phase to the launch
- the VPP results from an analytical process combining the consideration of technical risk, feasibility, availability of required means, schedule and cost
- the VPP drives the overall development of the project, of which it has to guaranty the successful completion
- the VPP includes at the same time the flight hardware and software to be certified and the support equipment necessary for this purpose
- the VPP involves the participation of all the project team (engineering, PA, AIV) and of all Contractors and Subcontractors.

For this purpose the VPP shall define:

- the necessary means and methods to demonstrate the compliance of the flight model with the Customer requirements
- the organisation implemented to control the good performance of the verification process
- the responsibility breakdown between the different Contractors at all levels and the concern of engineering, product assurance and AIV/AIT in the verification process.

The verification process will be considered completed when the Customer and the Supplier mutually agree that, on the basis of proper documented evidence, the identified requirements have been verified and the associated verification objectives fully reached. The requirements not fully verified at a certain level shall be identified and resolved.

9.5.1 Verification objectives

The verification objectives shall be primarily:

- a.** To qualify the design.
- b.** To ensure that the product is in agreement with the qualified design and is free from workmanship defects and acceptable for use.
- c.** To verify that the satellites (including tools, procedures and resources) will be able to fulfil mission requirements.
- d.** To confirm product integrity and performance after particular steps of the project life cycle (e.g. integration, test, and pre-launch).

The model philosophy supports the overall development of the satellites; the VPP is dedicated to ascertain, from the model philosophy, that the flight hardware delivered for launch will be capable to fulfil the mission requirements.

The verification objectives are:

- to achieve the mechanical qualification of each unit and subsystem (including instrument units), together with the mechanical qualification of the overall satellite (Herschel and Planck)
- to achieve the thermal qualification of each unit and subsystem (including instrument units), together with the thermal qualification of the overall satellite (Herschel and Planck)
- to achieve the cryogenic qualification of instrument cryogenic units, together with the cryogenic qualification of the overall PLM or satellite (Herschel and Planck)
- to achieve the electromagnetic qualification of each unit and subsystem (including instrument units), together with the electromagnetic qualification of the overall satellite (Herschel and Planck)
- to achieve the electrical and performance qualification of the design of each unit and subsystem (including instrument units), together with the performance verification of the overall satellite (Herschel and Planck) in all environment conditions
- to achieve the on-board software qualification, together with the functional qualification of the overall hardware and software system (Herschel and Planck)
- to achieve the certification of the compatibility of all elements of the complete Herschel/Planck programme having a part in the success of the missions: Herschel and Planck satellites and ground segment
- to achieve the full acceptance of each flight unit and subsystem (including instrument units), together with the acceptance of the overall satellite (Herschel and Planck).

9.5.2 Verification concept

The VPP covers all on-ground tasks up to the final acceptance review of the **Flight Models**.

The VPP shall serve to provide the maximum confidence obtainable within the financial and schedule boundary conditions.

To achieve these objectives, the VPP will provide visibility and appropriate control during the incremental verification steps and will ensure proper maintenance of the corresponding documentation.

The verification concept will be based on the specification of clearly defined verification requirements, which will be reflected within the Herschel/Planck engineering database. The verification requirements of the database will be derived from the satellite performance, operational and interface requirements as laid down in the Herschel/Planck requirements documents.

The Herschel/Planck engineering data base shall cover the above mentioned verification requirements and additionally provide all required information concerning the methods, types and levels of verification and the logical sequence of verification tasks on satellite level.

The verification process will be conducted on satellite level for Herschel and Planck hardware and software items. In special cases the satellite verification process will be extended to lower levels, if explicitly required by the satellite VPP.

Verification tasks performed at higher integration levels will use lower level results.

9.5.3 Verification approach

To reach the verification objectives a verification approach shall be defined in an early phase of the project by analysing the requirements to be verified taking into account:

- design peculiarities
- qualification status of candidate solution
- availability and maturity of verification tools
- verification and test methodologies
- programmatic constraints
- cost and schedule.

The basic verification approach shall be derived through an iteration process, based on technical/cost/schedule considerations, which define the "what", "how", "where" and "when" of verification by:

- identifying a consistent set of verifiable project requirements which can be subjected to the verification process
- selecting methods of verification
- selecting levels of verification and the associated model philosophy
- selecting facilities
- identifying resources required
- identifying the stages and the events in which the verification is implemented.

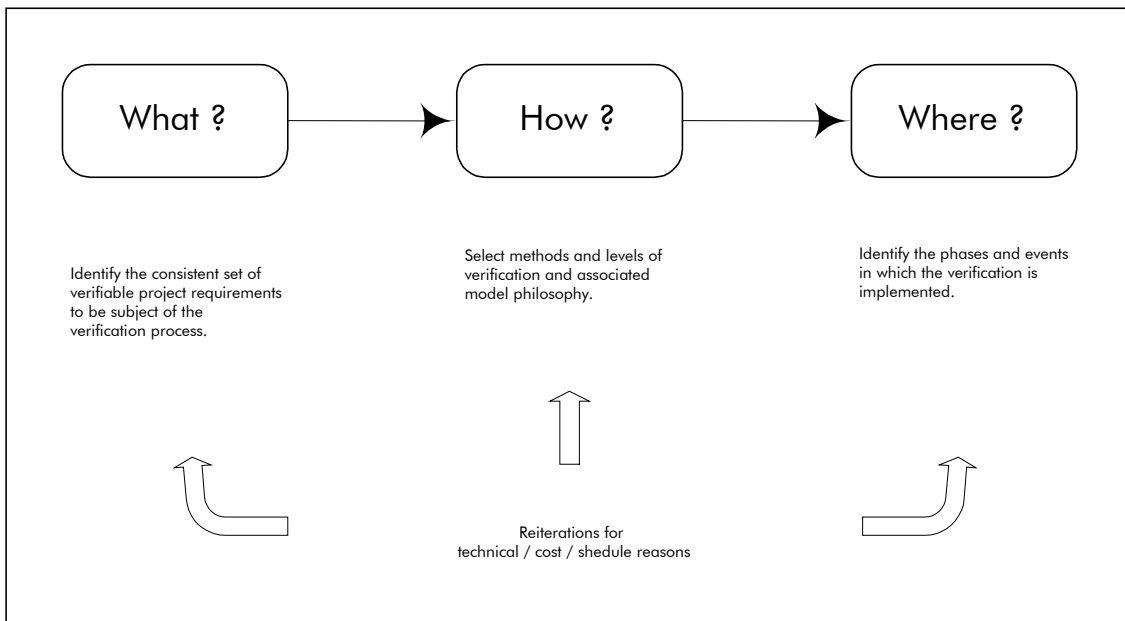

Table 9.5.3 Verification approach

9.5.4 Verification types

The verification consists of two types as follows:

– **Qualification (QUAL)**

The objective of the qualification is the formal contractual demonstration that the design implementation and manufacturing methods have resulted in hardware and software conforming to the specification requirements.

The purpose of qualification testing is also to demonstrate that the items perform satisfactorily in the intended environments with a sufficient margin.

The qualification levels shall be defined in order to cover the worst case environmental conditions, so they shall exceed the maximum predicted levels by a factor of safety which assures that, even with the worst combination of test tolerances, the flight levels will not exceed the qualification test levels.

This verification process starts with analysis and is completed by test, either using flight or non-flight hardware, provided that this hardware is representative for the test being performed.

The standard of qualification dedicated models may be slightly relaxed with respect to flight standard, by using lower quality MIL-Grade parts instead of the space qualified hi-reel ones (e.g. EQM), without affecting the test validity. Some minor changes to the models used for qualification testing are allowed, if they do not impact the qualification objectives, for example, in order to accommodate such items as thermocouples, strain gauges and monitoring leads, necessary to conduct the test.

This verification type may be split into:

- certification of the design established as early as possible by analysis and assessment or elementary tests at component or unit levels. The objective of this phase is to validate the design, select the options, evaluate the performances
- certification of the performances, to be carried out by test of flight representative hardware and correlation with the analysis results.

This stage may also include re-qualification in the case that the design is modified after initial qualification has been achieved.

– **Acceptance (ACC)**

Verification aimed at demonstrating by tests the compliance of the performance of the flight hardware with the requirements. This acceptance test sequence is nominally applied to any flight hardware from unit to satellite level.

The purpose of these tests is to demonstrate conformance to specification requirements and to act as quality control screens to detect manufacturing defects, workmanship errors, incipient failures and other performance anomalies, not readily detectable by normal inspection techniques. The acceptance tests are formal tests conducted to demonstrate the adequacy and readiness of an item for delivery and subsequent usage.

Acceptance testing should not create conditions that exceed safety margins or cause unrealistic modes of failure.

Acceptance tests are conducted on flight models under environmental conditions not more severe than those expected during the mission. The acceptance tests shall be conducted on all the flight products (including spares) according to the model philosophy.

For cost or schedule reduction the qualification demonstration completion may be carried out with the flight hardware itself (ProtoFlight philosophy). In this case a combined Qualification/Acceptance sequence will be applied to this hardware, but demonstration, by analysis and comparison between the test levels and the safety margins, shall be done that the flight hardware will not be over-stressed by the tests themselves.

The article involved in acceptance test shall be manufactured in agreement with the qualified design and shall perform as the qualified product.

This stage may also include re-certification in the case that the representative configuration is disassembled (e.g. due to failure or repair actions), or where it has undergone long-term storage.

9.5.5 Verification methods

Test, analysis, assessment or a combination may demonstrate fulfilment of a requirement. At least one of the following verification methods shall be selected for each of the individual performance requirements.

Whatever the verification method may be, the corresponding data shall be made available in form of reports (test, analysis, inspection reports, technical notes...). Correlation of test data with analysis data shall be made when applicable.

The verification process will start early in the development phase to demonstrate by analysis and evaluation the expected performance, the design feasibility and the compliance to the requirements.

Testing will be the main verification method and will be used as far as possible to verify the hardware performances and compliance with the specifications at each level. The other methods (analysis, assessment) will be dedicated to verify the requirements for which testing is not convenient or applicable, or to precede or complete the testing method.

At subsystem and system levels, testing will be the method to be used to validate the nominal and contingency procedures (including on-board software management: load, dump, check, ...) referenced in the Satellite User Manual (SUM).

The SUM will be used as a reference to generate the IST and the test reports. Test evaluations shall be used to maintain the SUM and to insure it is in line with the subsystem / system behaviour.

– Verification by Test (T)

Two different types of tests shall be implemented to verify the qualification or the acceptance of a unit, subsystem, module or satellite. These are functional tests under ambient conditions and environmental tests where external constraints are applied.

The functional tests consist of compatibility tests, interface tests and performance tests verifying that the electrical, mechanical or radio-electrical criteria are met. In general they are performed under ambient conditions, but for certain units they are only possible in thermal vacuum.

The environmental tests consist in a selection of tests to be carried out in an environment similar to that found during launch and/or during the mission phases.

– **Verification by Analysis (A)**

Verification by analysis may be performed and may replace tests at all levels in particular if it can be shown that analysis provides a better method of verification of requirements.

If verification is accomplished by analysis, the analytical method shall be established in terms of technical, cost and schedule advantages.

– **Verification by Similarity (S)**

Verification by similarity may be applied to equipment or subsystems coming from another programme when reuse “as is” or minor modifications are proposed and the environmental conditions are common or scoped by existing qualification.

For units coming from another programme and reused with no or minor modifications, an analysis of the qualification and acceptance test results of the other programme shall be carried out against the requirements of the current programme. Acceptance by ALCATEL of a proposal for Verification by Similarity will be done on a case by case basis.

– **Design Verification Assessment (E)**

Verification by Assessment may be achieved by Inspection or by Review Of Design. In each case, the Contractor will have to provide a full technical assessment, detailing the conformity of the part to the applicable requirements for the intended application.

9.5.6 Verification levels

The different verification operations shall be carried out at equipment, subsystem, module or system levels. The VPP shall ensure the coherence and the complementarity of all these verification steps in order to ascertain that the full verification process covers entirely the specification requirements. The Manufacturer or Contractor responsible for the AIV task of the corresponding level (equipment, subsystem, group of subsystem, module or satellite will perform the verification operations).

9.5.6.1 Equipment level (EQ)

The unit or equipment specifications are the base of the lower level verification process. All specification requirements have to be verified and demonstration has to be done that the unit fulfils its own requirements and the general applicable system requirements such as design, EMC, environmental specifications.

The same verification process as for satellite level is applicable to equipment level. The Manufacturer shall demonstrate that the two verification types have been performed using appropriate methods.

The unit VPP will define case by case the test philosophy applicable in order to achieve a complete qualification at Herschel/Planck programme levels, taking into account the actual status of the design and the classification expressed in §6.6.

It is the task of each Subcontractor/Manufacturer:

- to justify through the documentation (unit & subsystem specifications, design description, performance evaluation...) the design of each unit, component or subsystem under his responsibility w.r.t. the system specifications
- to certify the design, manufacture and performance (analysis and calculation files, drawings, manufacturing procedures and processes...) of each item w.r.t. the Herschel/Planck requirements
- to verify before delivery the compliance of hardware with the accepted design (qualification or acceptance test sequences).

In particular, if the equipment qualification cannot be considered as fully achieved for the programme by similarity with another one, the Manufacturer, according to the qualification plan, shall demonstrate on a specific model, that the unit meets all the qualification requirements (expected flight environment levels with a proper margin).

For Herschel/Planck the present status is presented in Tables 9.4.6.1-1 to-3.

**Design & Development Plan
(DDP)**

Doc. n° H-P-1-ASPI-PL-0009

Issue: 4 / Revision: 1

Date: 8/11/2004

Page 142/155

MODULE	SUBSYSTEM	Type	Remark
	Equipment		
SVM	PRIMARY STRUCTURE		
	Central Cone & webs	D	
	Instruments Panels	D	
	"Service" Panels	D	
	Platforms	D	
	Brackets	D	
SVM	HARNESS		
	Primary Power	C	
	Signal	C	
	Others (supports, ...)	B	
SVM	THERMAL CONTROL		
	Multi Layer Insulation	A	
	Heaters	A	
	Thermistors	A	
	Coating (Paints, SSM, OSR)	B	
	Heat-pipes	C	
SVM	POWER CONDITIONING		
	PCDU	D	
	Batteries	D	
SVM	PLANCK SOLAR ARRAY		
	Panel Structure	D	
	Electrical Wiring	A	
	S/A Cells	C	complementary or full functional and qualification testing

**Table 9.5.6.1-1a SVM Equipment Classification w.r.t. Qualification Status
[H-SVM] & [P-SVM]**

**Design & Development Plan
(DDP)**

Doc. n° H-P-1-ASPI-PL-0009

Issue: 4 / Revision: 1

Date: 8/11/2004

Page 143/155

MODULE	SUBSYSTEM Equipment	Type	Remark
SVM	PROPULSION		
	20 N Thruster	A	
	1 N Thruster	B	
	Tanks	C	
	Latch Valves	A	
	FVV	A	
	Fill & Drain Valve	A	
	Pressure Transducer	A	
	Filter	A	
	Piping	B	
	Brackets	B	
SVM	CDMS		
	CDMU	D	
SVM	TT & C		
	Transponder	D	
	RFDN	B	
	TWTA	C	
	EPC	C	
	Med. Gain Antenna	C	
	Low Gain Antenna	C	
SVM	ACMS		
	ACC	D	
	Reaction Wheel System	B	
	Gyro Unit & Electronic	B	
	Star Tracker Sensor & Electronic	B	
	CRS	B	
	Sun Acquisition Sensor	B	
	Attitude Anomaly Detector	B	

**Table 9.5.6.1-1b SVM Equipment Classification w.r.t. Qualification Status
[H-SVM] & [P-SVM]**

**Design & Development Plan
(DDP)**

Doc. n° H-P-1-ASPI-PL-0009

Issue: 4 / Revision: 1

Date: 8/11/2004

Page 144/155

MODULE	SUBSYSTEM	Equipment	Type	Remark
Planck PLM	Cryo-Structure			
		Struts	D	
		Grooves	D	
		Main Baffle	D	
Planck PLM	Telescope			
		Structure	D	
Planck PLM	Thermal Control			
		MLI's	C	
		Thermal braids	D	
		Heaters	A	
		Temperature sensors	A	
		ATC Harness	A	

**Table 9.5.6.1-2 Planck PLM Equipment Classification w.r.t.
Qualification Status
[P-PLM]**

**Design & Development Plan
(DDP)**

Doc. n° H-P-1-ASPI-PL-0009

Issue: 4 / Revision: 1

Date: 8/11/2004

Page 145/155

MODULE	SUBSYSTEM	Equipment	Type	Remark
Herschel E-PLM	Cryostat Structure			
	Cryostat Vacuum Vessel		D	
	Tank straps		B	ISO
	Spatial Framework		D	
	Cryostat Cover		D	
	Radiators		D	
	Entrance Baffle		D	
	Instrument Optical Bench		D	
Herschel E-PLM	Cryostat Helium			
	He II Tank		D	
	Passive Phase Separator		B	ISO
	Liquid Measurement Device		A	ISO
	He II Probe		B	ISO
	He I Probe		B	ISO
	Tank Surface Thermometer		B	ISO
	Tank Heaters		A	ISO
	Ventline		A	ISO
	Rupture Disc		A	ISO
	Safety Valves He II		B	ISO
	Safety Valves He I		A	ISO
	Safety Valves Cryostat Vessel		A	ISO
	Absorber		B	ISO
	Filling Port		C	ISO
	Ext. & Int. Liquid Helium Valves		B	ISO
	He I Tank		D	
	He I Pressure Sensor		B	ISO
	He I Ventline External Heater		B	ISO
	He I Tank Surface Thermometer		C	
	Ventline Nozzle		D	
	Vacuum Measurement Sensor		B	ISO
	Tubing		D	

**Table 9.5.6.1-3a Herschel E-PLM Equipment Classification w.r.t.
Qualification Status
[H-EPLM]**

**Design & Development Plan
(DDP)**

Doc. n° H-P-1-ASPI-PL-0009

Issue: 4 / Revision: 1

Date: 8/11/2004

Page 146/155

MODULE	SUBSYSTEM Equipment	Type	Remark
Herschel E-PLM	Cryostat Insulation		
	Internal & External MLI's	B	
	Thermal Shields	B	ISO
Herschel E-PLM	Cryostat Electrical		
	Cryostat Control Unit (CCU)	C	ISO
	Instrumentation	C	ISO
	Cryo Harness	D	
Herschel E-PLM	Structures		
	Cryostat/SVM Interface Struts	D	
	SVM Shield	D	
	BOLA Support Structure	D	
	LOU Support Structure	D	
	Optical Windows	D	
	LOU Wave-guides and Support	D	
	Telescope Mounting Structure	D	
	Harness Supports	B	
	MLI Supports	B	
Herschel E-PLM	SUNSHIELD/SUNSHADE		
	Structural Panels	D	
	Support Struts	D	
	Electrical Wiring	D	
	OSR	A	
	Solar Cells	C	complementary or full functional and qualification testing

**Table 9.5.6.1-3b Herschel E-PLM Equipment Classification w.r.t. Qualification Status
[H-EPLM]**

9.5.6.2 Subsystem level (SS)

The subsystems Subcontractor shall demonstrate by test the full compatibility and performance of his subsystem before delivery to module or system AIT.

This demonstration is usually a collation of unit level test results, completed if necessary by a series of functional tests at defined temperatures, in order to ascertain, that the overall subsystem fulfils its requirements (S/S acceptance test sequence).

The environmental tests will be performed at unit level or at higher level rather than at subsystem level. When several units or components have to be tested together under environmental conditions to demonstrate the S/S qualification, this will be done at satellite or module or subassembly level through the STM, QM or FM/PFM sequences.

9.5.6.3 Module or subassembly level (MO)

A module is defined as a group of subsystems constituting mechanically and functionally a self-sufficient element of the satellite that can be tested and qualified as a whole.

This definition excludes simple subsystems such as power or TT&C S/S which are not mechanically independent, but corresponds to the Herschel and Planck telescopes, and obviously to the Extended Payload and Service Modules.

The mechanical or thermal qualification of a module is a significant step that may simplify the corresponding satellite qualification and allows obtaining significant results earlier in the programme schedule.

9.5.6.4 System level (SA)

The satellite level verifications will be performed using the development models (STM, AVM and FM/PFM) to complete the unit and subsystem verifications.

The proposed verification philosophy leads to consider the single flight model as a Proto-Flight in order to complete the qualification on a fully representative model, when the lower level tests combined with the system tests performed on the development models are not conclusive enough.

So the VPP will be conducted step by step by a combination of tests at unit, subsystem, module and satellite levels. Collation of all verification results at each level will allow declaring the formal system qualification and acceptance.

When it is not possible to test the satellite as a single entity, major assemblies or modules or stages of the S/C will be tested instead, with the support of suitable analyses, simulations and/or simulators.

9.5.7 Verification Matrixes

The VPP includes Verification Matrixes issued by the relevant responsible of any hardware and software item, from the requirements of the corresponding level specifications.

The unit matrixes issued from the Manufacturers will be collated at subsystem level and the Subcontractor responsible for the subsystem will add additional level of verification referenced to the subsystem specifications, if any.

The major Subcontractors of the PLMs and of the SVMs will define the module verification matrixes, based on the module level specifications. They will sum up the information coming from the lower level matrixes that will be used to govern the module level AIV.

The Prime Contractor will define the system verification matrix, based on the system level specifications. It will sum up the information coming from the lower level matrixes that will be used to govern the system level AIT.

This plan will be used all along the development and test phases and filled in when performed, with references to the corresponding justifying documents (technical note, analysis report, test report...) allowing to verify that it has been properly followed.

The verification matrixes will indicate:

- the parameters and functions to be verified (after analysis of the specifications requirements)
- the specification they stem from
- the level of verification: unit, subsystem, module, system (the same verification may be performed at several levels)
- the selected verification method: test, analysis, assessment (several complementary methods may be used)
- Comments if any

**Design & Development Plan
(DDP)**

Doc. n° H-P-1-ASPI-PL-0009
 Issue: 4 / Revision: 1
 Date: 8/11/2004
 Page 150/155

Satellite Name: <Herschel> and/or <Planck>
 Reference Document: <Name> <ID> <Issue/revision> <Date>
 Upper Reference Document: <Name> <ID> <Issue/revision> <Date>

Req. Numb.	Header Text	Traces (1)	Types (2)	Verification methods (3)				Remark
				SA	MO	SS	EQ	
			QUAL, ACC	T, A, S, E	T, A, S, E	T, A, S, E	T, A, S, E	

- (1) Traces = Requirement number in upper Reference Document
- (2) Types = Q for qualification, A for Acceptance
- (3) Verification methods = T for test, A for Analysis, S for assessment by similarity, ROD for assessment by Review of design

Figure 9.5.7: Example of Verification Matrix Sheet Format

9.5.8 Test Requirement Sheets

The VPP includes Test Requirement Sheets (TRS) to be issued with the support of the engineering team. This TRS issued prior to the Test Requirement will content at least the following information:

Test to be performed	Exact wording of the test to be performed				
Specimen to be tested	<i>Satellite</i>	<i>Level</i>	<i>Model</i>	<i>Type</i>	<i>Number</i>
<p>TEST OBJECTIVES <i>Objectives of the test and how and why it aims at fulfilling a relevant requirement.</i></p> <p>TYPE OF TEST <i>Summary of the test to be performed.</i></p> <p>SUMMARY TEST DEFINITION</p> <p>- Satellite test definition <i>Simplified configuration of the item to be tested</i></p> <p>- Environment <i>Type of Clean room Class</i> <i>Type of "thermal" environment: ambient, cryogenic,...</i> <i>Definition of the environment to be applied in case of environmental test</i></p> <p>- Test sequence <i>Sequence of the test itself but also its position in the overall test flow.</i></p> <p>- Measurements Definition <i>List and type of measurements requested in the frame of the test</i></p> <p>TEST SET UP AND TEST SUPPORT <i>Ground Support Equipment and test facility requested by the test as well as the outputs requested for its evaluation.</i></p> <p>TEST ACCEPTANCE CRITERIA <i>Criteria to conclude on the end of the test itself and to give the go-ahead for the next one.</i></p> <p>RESPONSIBILITIES <i>Responsibility of each company/team for the relevant tasks</i></p>					

9.5.9 Analysis Requirement Sheets

The Analysis Requirement Sheets (ARS) present analyses aiming at demonstrating the system performances not verifiable by a global or End to End test. The engineering team will issue these ARS in early Phase C/D and will content at least the following information:

Performances to be demonstrated	
Analysis to be performed	
<p>ANALYSIS OBJECTIVES <i>Objectives of the analysis and how and why it aims at fulfilling a relevant requirement that cannot directly verify by test.</i></p> <p>TYPE OF ANALYSIS <i>Summary of the analysis to be performed.</i></p> <p>TESTS TO BE PERFORMED List of tests performed at System and/or lower levels with inputs for system analysis.</p> <ul style="list-style-type: none">- List of tests performed at System level <i>Reference to relevant TRS</i>- List of tests performed at lower levels <i>Reference to test performed at lower levels</i>- Test sequence <i>Sequence of the above tests with their position in the verification flow.</i> <p>RESPONSIBILITY <i>Responsibility of each company/team for the relevant tasks</i></p>	

9.6 VERIFICATION CONTROL DOCUMENT (VCD)

When a specified requirement is verified, reference of the approved document demonstrating its fulfilment is filled in the Verification Control Document (VCD).

The VCD will provide clear visibility of the complete verification process. That means, the starting point of the process for the Herschel/Planck satellite verification and its control are formed by the requirements of the Herschel/Planck Engineering database that is derived from the ESA maintained Requirements Documents.

The VCD maintenance covers:

- monitoring of the verification activities (tests, analyses, design reviews, inspections)
- updating of the respective documentation
- the incorporation of the results into the Engineering Data Base

The VCD will indicate:

- the parameters and functions to be verified (after analysis of the specifications requirements)
- The reference of the RFW, if any
- the level of verification: unit, subsystem, module, system (the same verification may be performed at several levels)
- the selected verification method: test, analysis, assessment (several complementary methods may be used)
- the reference of documents where this verification is precisely defined (AIT plan, test plan, test procedure, ...)
- the reference of the verification report. Once the verification has been performed
- the verification status to follow the progress of the VPP.

For verification of items of lower hierarchical level, the same procedure will be applied with same documents and responsible personnel.

**Design & Development Plan
(DDP)**

Doc. n° H-P-1-ASPI-PL-0009
 Issue: 4 / Revision: 1
 Date: 8/11/2004
 Page 154/155

Satellite Name: <Herschel> and/or <Planck>
 Reference Document: <Name> <ID> <Issue/revision> <Date>

Req. Numb.	Text	Header	Serial Numb.	RFW	Verification methods				Verif plan	Verif. Report	Status O/C	Remark
					SY	Mod.	S/S	Unit				
(4)					(4)	(4)	(4)	(4)	(1)	(2)	(3)	

- (1) = test specification, ...
- (2) = test evaluation, or analysis, or relevant document for assessment by Similarity or ROD
- (3) = O for on-going verification, C for successfully achieved verification
- (4) from Verification Matrix

Figure 9.5: Example of VCD Sheet Format

10 ANNEX PLANCK TELESCOPE FM VERIFICATION APPROACH

Due to reasons expressed in § 6.4.2, the alternative for the reconstruction of the Planck FM Telescope WFE is the following and is based on characterisation of element in cryo environment in two steps:

- Step #1: FM Reflectors
 - interferometry method at CSL as done on QM Reflectors (sub-pupil measurements and local deformation including quilting),
 - video-grammetry method to quantify the change from ambient to cryogenic environment (global deformations),
- Step #2: FM Telescope equipped with FM Reflectors and STM LFI Main Frame (TBC)
 - global telescope alignment verification under cryogenic environment with the objective of a best focus measurement with adequate wavelength and relevant set-up (video-grammetry method to quantify the change from ambient to cryogenic environment is also under consideration).

This promising alternative is under definition and the final approach will be reflected in [RD7].

END OF DOCUMENT