

**HERSCHEL / PLANCK**

**Herschel system alignment plan  
H-P-2-ASPI-PL-0276**

**Product Code: 100000**

Rédigé par/ <i>Written by</i>	Responsabilité-Service-Société <i>Responsibility-Office -Company</i>	Date	Signature
Ph. MARTIN	Optical Engineering	01/02/07	
<b>Vérifié par/<i>Verified by</i></b>			
T. VIARD	Head of Optical Engineering Service	10/01/07	
Ph. CLAVEL	Mechanical architecture	17/01/07	
Y. ROCHE	Herschel System Engineer	19 JAN 07	
B. GOBILLOT	Herschel AIT manager	22.01.07	
<b>Approbation/<i>Approved</i></b>			
T. GRASSIN	P.A. Manager	23.01.07	
D. MONTET	Herschel Manager	22.01.07	
J.J. JUILLET	Herschel/Planck Project Manager	29.01.07	

**Entité Emettrice** : Alcatel Alenia Space – France  
(détentrice de l'original) :

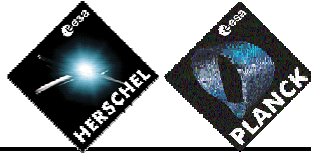

HERSCHEL/PLANCK		DISTRIBUTION RECORD	
DOCUMENT NUMBER : H-P-2-ASPI-PL-0276		Issue 04/ Rev. : 00 Date:1 Feb 2006	
EXTERNAL DISTRIBUTION		INTERNAL DISTRIBUTION	
ESA	X	HP team	X
ASTRIUM	X		
ALENIA	X		
		Clt Documentation	Orig.

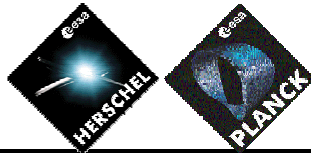

ENREGISTREMENT DES EVOLUTIONS / CHANGE RECORDS

ISSUE	DATE	§ : DESCRIPTION DES EVOLUTIONS § : CHANGE RECORD	REDACTEUR AUTHOR
01	26 Jun 2002	First issue Herschel-Planck PDR	Ph MARTIN
02	16 Feb 2004	Second issue New star tracker accommodation The star-tracker is aligned on PLM - X direction, and no more on PACS LOS Differentiation between the thrusters to be aligned and the others Inclusion and justification of the roll requirement on the H-PLM (already included in the H-PLM requirement spec) More precision is given on the SVM equipments to be aligned or checked at satellite level. The current knowledge of the several LOS used at Satellite level is given in annex PDR RIDS CRYO 114 and CRYO 116 are covered	Ph. MARTIN
03 04	23 Jul 2004 1 Feb 2007	H-P System CDR H-P system QR EQM STM campaign descriptions and lessons learnt are included STM and FM modules activities are described more precisely M1-M2 distance added	Ph. MARTIN Ph. MARTIN

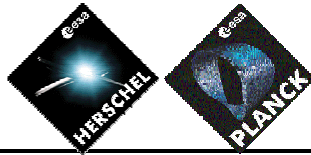

## TABLE OF CONTENTS

1. INTRODUCTION	6
1.1 Purpose of this document	6
1.2 Reference and applicable documents	8
1.2.1 Applicable documents	8
1.2.2 Reference documents	8
1.3 Acronyms	10
2. HERSCHEL SPACECRAFT DESCRIPTION	11
2.1 Herschel Spacecraft Sketch	11
2.2 Star/tracker accommodation	12
2.3 pointing performance	13
2.3.1 In-orbit calibration policy	13
2.3.2 Instrument LoS	13
2.3.3 ACMS units	14
2.3.4 Thruster plumes exhaust direction.	14
2.4 Optical performance	15
2.4.1 Focus	15
2.4.2 pupil mismatch	15
2.4.3 LOU and HIFI FPU co-alignment	15
3. UPPER LEVEL ALIGNMENT NEEDS	16
3.1 Alignment needs wrt pointing budget	16
3.1.1 LOS	16
3.1.2 around LOS	17
3.2 Alignment needs wrt thrusters	18
3.3 alignment needs wrt image quality performance	19
3.3.1 focus	19
3.3.2 pupil mismatch	19
3.4 HIFI FPU to LOU alignment and stability	19
3.4.1 Absolute alignment	19
3.4.2 In-orbit short term stability	19
4. EQM/STM CAMPAIGN	20
4.1 EQM campaign	20
4.1.1 objectives	20



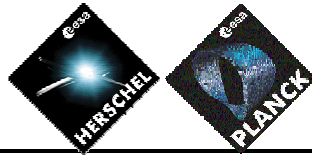

4.1.2	alignment activities	20
4.1.3	lessons learnt	20
4.2	STM campaign	20
4.2.1	objectives	20
4.2.2	alignment activities	21
4.2.3	lessons learnt	24
5.	FM ALIGNMENT SEQUENCE	26
5.1	SVM alignment measurements	27
5.2	Alignment sequence at H-PLM level	27
5.3	Alignment sequence at Herschel satellite level	28
5.3.1	alignment sequence	28
5.3.2	alignment objectives	28
5.3.3	spacecraft mechanical axes determination (see [RD26])	30
5.3.4	Spacecraft alignment measurement and alignment checks (see [RD9])	30
5.3.5	Thrusters exhaust directions alignment (see [RD27])	32
5.4	alignment measurements during TB/TV	33
5.4.1	HACS	33
5.4.2	Videogrammetry	33
5.5	Telescope M1-M2 distance measurement	36
6.	SYSTEM ALIGNMENT CONTRIBUTORS ALLOCATIONS	37
6.1	contributions to alignment allocations with regards to pointing budget	37
6.1.1	HPLM /Star – tracker LOS alignment	37
6.1.2	AROUND LOS-Allocations	39
6.2	allocations to thruster plumes exhaust directions alignment	39
6.2.1	alignment accuracy – contributors	39
6.2.2	alignment accuracy-allocations	39
6.2.3	thruster plume adjustment range – contributors	42
6.2.4	thruster plume exhaust directions adjustment range – allocations	42
7.	REQUIREMENTS	44
7.1	At H-PLM level	44
7.2	At-SVM level	45
7.3	At system level	45
APPENDICES :		46

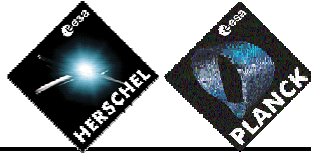

## 1. INTRODUCTION

### 1.1 Purpose of this document

This document provides the alignment plan for Herschel satellite. It describes the alignment needs, means, and verification at satellite level **and recalls the main points of HPLM and SVM alignment plans.**

**The objective of this plan is to explain the logic who enables, from the measurements at unit, module and S/C levels, building the alignment budgets and demonstrating the correct alignment of the S/C.**

**Note that the budgets are maintained in a dedicated document H-P-ASP-AN-1256**

This plan starts from the system alignment needs, as given by the

- Attitude and Control Monitoring system
- **image quality need**
- **pupil mismatch needs**

**The STM campaign is reminded and the lessons learnt are reported**

**The FM sequence and alignment activities are described**

Based on the alignment sequence, the contributors to each requirement are identified. A justified allocation is made for each one of them.

This plan also defines the optical interfaces and associated OGSE necessary to implement this alignment concept.

Finally the alignment requirements at sub-system level are synthesized.

This is illustrated by the following flowchart:

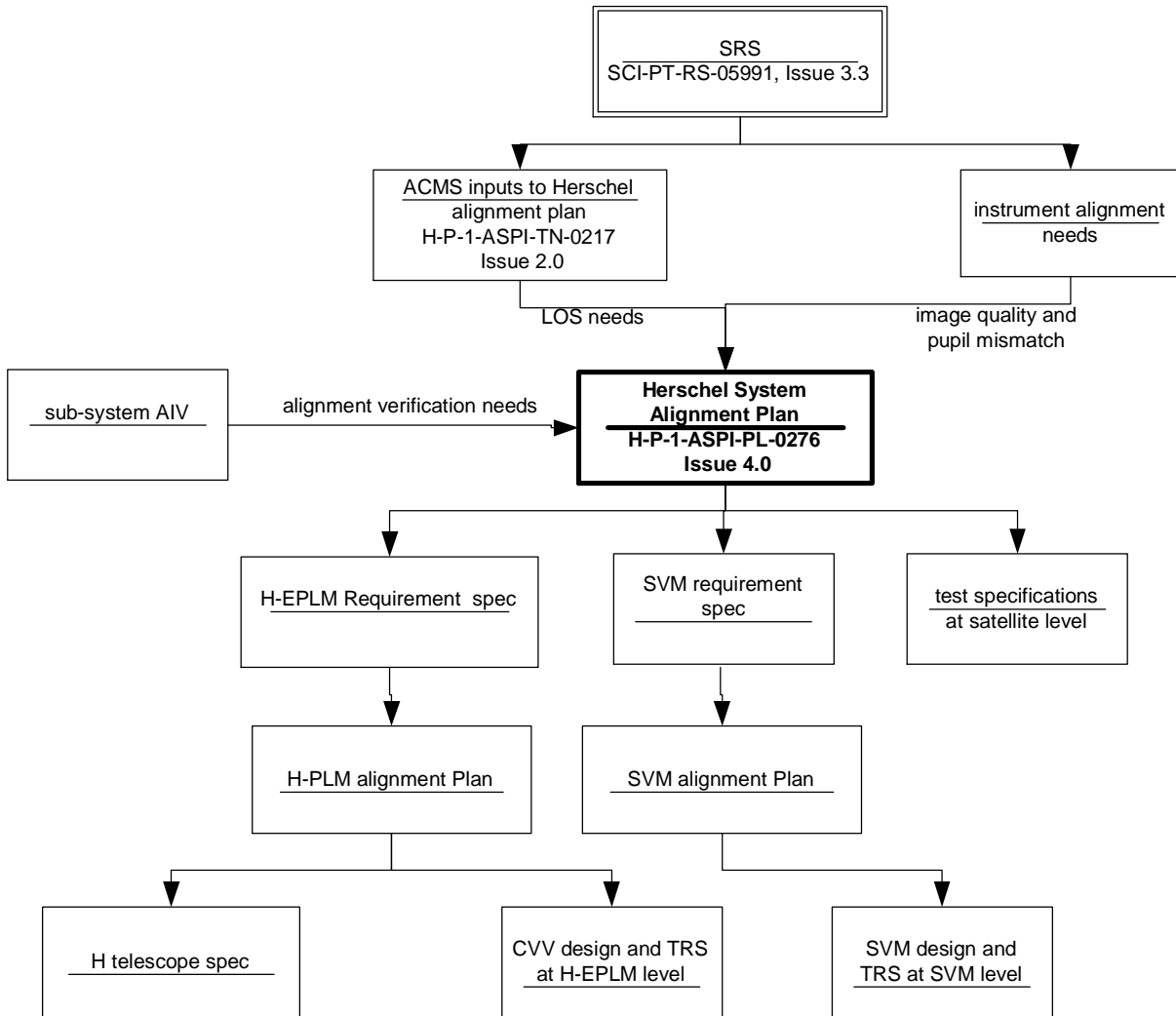
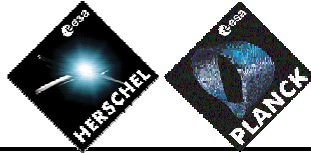
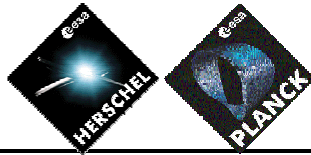

Figure 1-1 requirements flow down from SRS down to modules design



## 1.2 Reference and applicable documents

### 1.2.1 Applicable documents

- [AD1] "System Requirement Specification"  
SCI-PT-RS-059111 Is/Rev 3/3
- [AD2] "STB of alignment tools Cube-tooling ball-target"  
ref ASPI/01/BO/IT/MP/034
- [AD3] "Inputs to Herschel System Alignment Plan"  
ref: H-P-2-ASPI-TN-0217 is/rev 2.0
- [AD4] "Herschel and Planck Pointing budget module allocation"  
ref H-P-1-ASPI-BT-0176 is/Rev 3/0
- [AD5] "PACS Instrument Interface Document"  
ref: SCI-PT-IIDB-PACS-02126 issue 4/0
- [AD6] "SPIRE Instrument Interface Document"  
ref: SCI-PT-IIDB-SPIRE-02124 issue 4/0
- [AD7] "HIFI Instrument Interface Document"  
ref: SCI-PT-IIDB-HIFI-02125 issue 3/3

### 1.2.2 Reference documents

- [RD1] "SVM Requirements spec"  
ref H-P-4-ASPI-SP-0019 Is/Rev 6/0
- [RD2] "Herschel SVM: Interface with CVV struts and SSH struts"  
ref F0278C HESA 180S000S A Ind H
- [RD3] "Herschel PLM alignment methods plan and results "  
ref H-P-2-ASED-TN-0097 Is 2
- [RD4] "H-EPLM requirements specification"  
REF H-P-2-ASPI-SP-250 Is/Rev 3/3
- [RD5] "SVM structure specification"  
ref H-P-SP-AI-0001 Is/Rev 7/0 15.03.04
- [RD6] HERSCHEL-PLANK SVM ALIGNMENT PLAN,  
ref H-P-PL-AI-0049 issue 1
- [RD7] Herschel Mechanical axis Determination Test requirement  
H-P-2-ASP-SP-0919 issue 1/0
- [RD8] Test requirement Sheet "thrusters alignment "  
H-SAT-ALG-2
- [RD9] Herschel alignment and stability test specification  
H-P-2-ASP-SP-0920 issue 3/0
- [RD10] RCS thruster bracket assy's user's manual  
H-P-RILAM-MA-0005

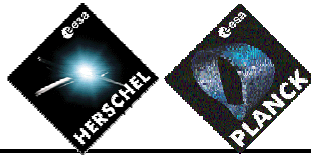

- [RD11] HERSCHEL MCI test specification  
H-P-2-ASP-TS-0782 issue 2/0
- [RD12] HERSCHEL STM alignment test campaign evaluation report  
H-P-2-ASP-TR-1239 issue 1/0
- [RD13] Herschel SVM STM alignment test report  
H-P-RP-AI-0127 issue 2/0
- [RD14] Herschel OBA mechanical integration report  
HP-2-ASED-RP-0151 issue 1/0
- [RD15] EQM alignment measurement report  
HP-2-ASED-TR-0103 issue 1/0
- [RD16] Herschel STM alignment Measurement report – part 1  
HP-2-ASED-TR-0094 issue 1/0
- [RD17] HACS measurement for STM during TB/TV  
HP-2-ASED-TR-0138 issue 1
- [RD18] H-EPLM alignment and straylight panel progress status  
H-P-ASP-MN-8262 dated 19/09/2006
- [RD19] HIFI alignment meeting  
HP-2-ASED-MN-1198 dated 05/04/2006
- [RD20] Siegmund E-mail dated “alignment open points”  
dated 12/04/2006
- [RD21] STM alignment stability TRB  
H-P-ASP-MN-8473 dated 14/11/2006
- [RD22] S/C stability before/after environment  
H-P-100000-ASP-NC-2581
- [RD23] SVM stability before/after environment  
H-P-100000-ASP-NC-2582
- [RD24] SVM panel opening / closing instability  
H-P-100000-ASP-NC-2583
- [RD25] RFW for Telescope defocus in cryo  
HER.RFW.1035.T.ASTR rev 0
- [RD26] Herschel satellite mechanical axis determination test specification  
H-P-2-ASP-TS-0919 issue 1/0
- [RD27] Herschel satellite thrusters alignment  
H-P-2-ASP-TS-XXXX (not yet issued)
- [RD28] Herschel Telescope ICD  
HER.NT.0052.T.ASTR issue 5/0
- [RD29] Herschel Telescope QR  
SCI-PT-44835
- [RD30] PM#29 videogrammetry splinter meeting  
H-P-ASP-MN-8626 dated 13/12/2006

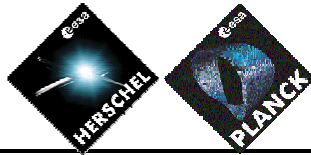

[RD31] Herschel Telescope M1-M2 distance Measurement procedure  
HER.PR.1041.T.ASTR issue 2/0

[RD32] Herschel Telescope M1-M2 distance Measurement report  
HER.RPT.1005.T.ASTR issue 1/0

### 1.3 Acronyms

AAD	Attitude Anomaly Detector
AC	Alignment Cube
ACMS	Attitude Control Monitoring System
AOCS	Attitude and Orbit Control System
CoG	Center of Gravity
CRS	Coarse Rate Sensor
HACS	Herschel Alignment Camera System
H-(E)PLM	Herschel (Extended) Payload Module
HP	Herschel-Planck
I/F	Interface
LoS	Line of Sight
MRC	Master Reference Cube
QR	Qualification Review
RSS	Root Sum Squared
RWL	Reaction Wheel
SAS	Sun Acquisition Sensor
S/C	Spacecraft
S/P-I/F	SVM/H-PLM interface plane
SRS	System Requirements Specification
SVM	Service Module
TBC	To Be Confirmed
TBD	To Be Defined
TRS	Test Requirement Sheet

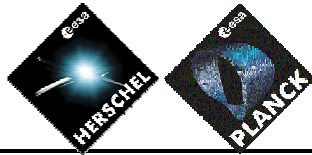

## 2. HERSCHEL SPACECRAFT DESCRIPTION

### 2.1 Herschel Spacecraft Sketch

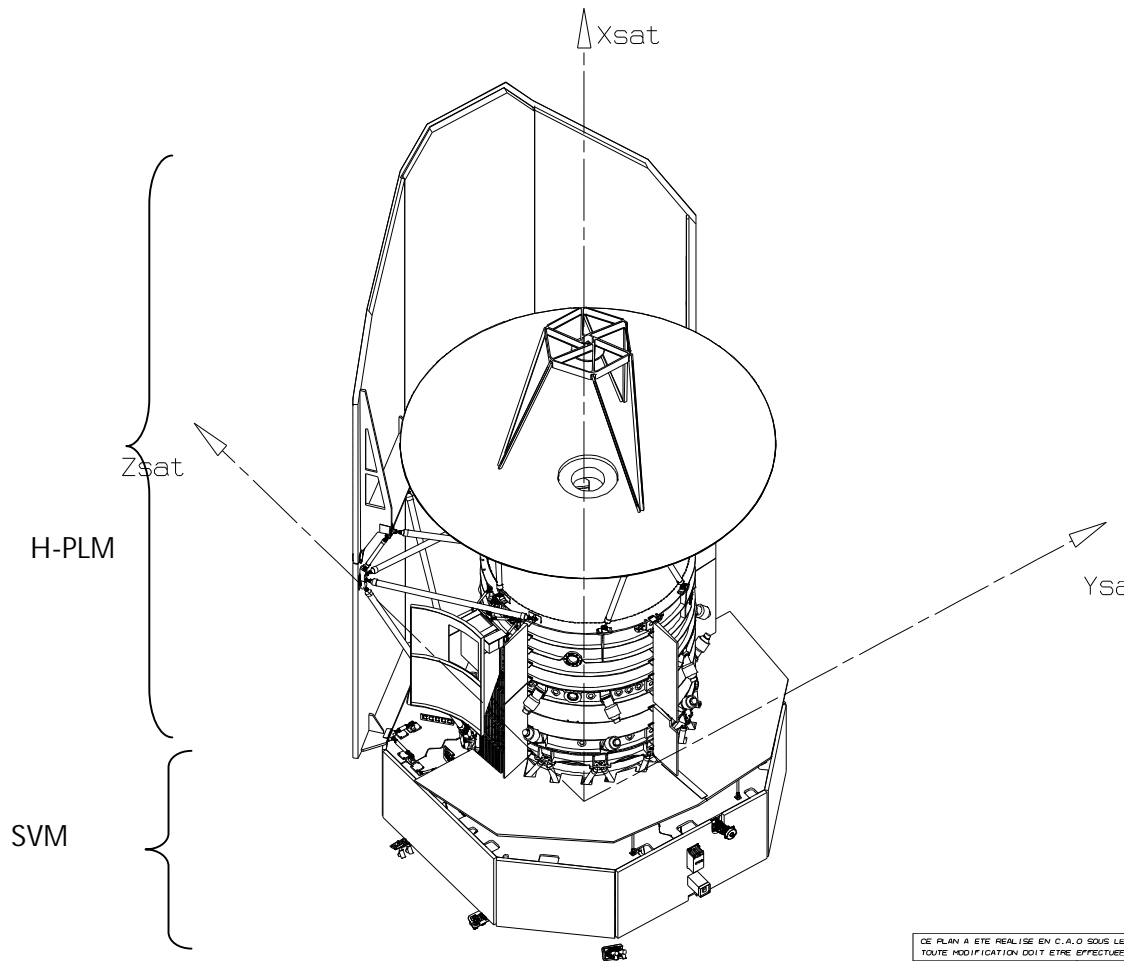

CE PLAN A ETE REALISE EN C.A.O SOUS LE  
TOUTE MODIFICATION DOIT ETRE EFFECTUEE  
PROTECTION - ETAT DE

Figure 2-1 Herschel S/C axis

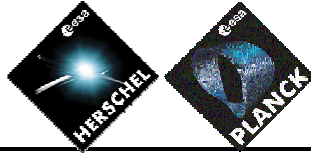

## 2.2 Star/tracker accommodation

The star trackers are looking toward S/C  $-X$  axis, and are mounted on a baseplate, which is mounted below the CVV via 3 bipods. There is no mechanical interface between the star trackers and the surrounding SVM.

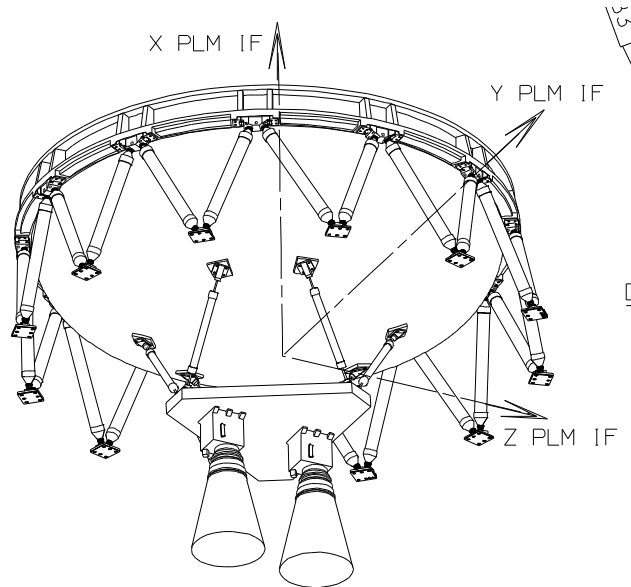
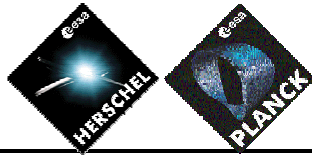

Figure 2-2 for stability reason, star trackers are interfaced to PLM , not SVM  
Note that, despite this accommodation, STR are functionally part of SVM





## 2.3 pointing performance

This section presents the units to be considered for alignment, in view of the system ACMS performance

### 2.3.1 In-orbit calibration policy

The system alignment logic is based on an in-orbit calibration of PACS LOS wrt star tracker LOS. SPIRE (resp. HIFI) LOS pointing is then computed, using the on-ground measurement of SPIRE (resp. HIFI) LOS wrt PACS LOS.

### 2.3.2 Instrument LoS

As per SRS [AD1], the LoS of an instrument is defined as the direction on the observed sky of the geometric center of an FPU entry beam's far field pattern as projected by the telescope. At satellite level, this direction is referenced with regards to the satellite/launcher interface ring.

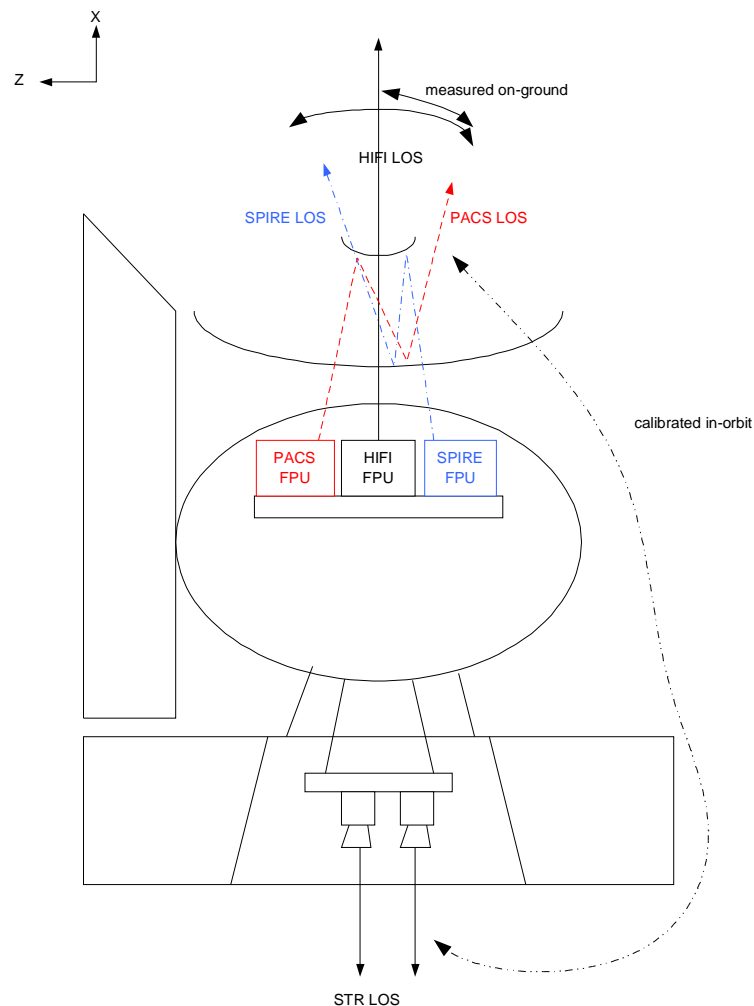
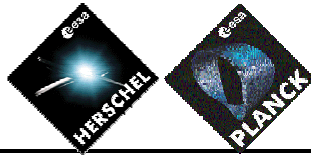

Figure 2-3 instruments LOS schematic projection on the sky

PACS and SPIRE FOV are symmetric with regards to HIFI, each one being at  $\pm 0.17^\circ$  along Z



### 2.3.3 ACMS units

Herschel SVM ACMS is composed, on top, of STR (see section 2.2), by 4 additional units for which alignment and/or alignment knowledge and/or alignment stability is important: these units are

- 1 Gyroscope (GYR)
- 2 Coarse Rate sensors (CRS)
- 1 Attitude anomaly Detector (AAD)
- 4 Reaction wheels (RWL)

The LOS of these units are given in annex

### 2.3.4 Thruster plumes exhaust direction.

To each thruster plume corresponds an exhaust direction, which is measured with a specific alignment tool (see annex). Out of 12 thrusters, 4 (the so-called "A" thrusters) have to be adjusted – on ground – with regards to the actual S/C CoG.

Y and Z coordinates of this CoG will be measured, according to [RD11].

## 2.4 Optical performance

This section gives an overview of the optical interface At PLM level

### 2.4.1 Focus

In order to have a sharp image, the instruments FPU have to be located at Telescope focus (along X).

### 2.4.2 pupil mismatch

The optical system stop is located on the telescope M2. In order to avoid any significant vigneting, the position of the instruments entrance pupil shall coincide with M2. note that instruments pupil are oversized.

### 2.4.3 LOU and HIFI FPU co-alignment

There is a stringent requirement onto the PLM for alignment and alignment stability – at operational conditions, of LOU with regards to HIFI FPU. This is due to the HIFI need of minimizing the optical coupling losses between the two units.

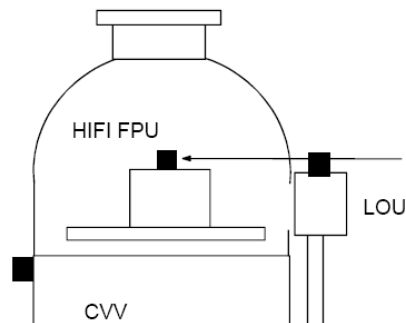
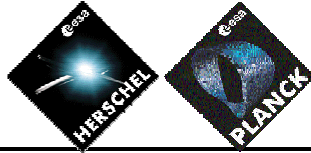

Figure 2-4 LOU to HIFI FPU coalignment - schematic



### 3. UPPER LEVEL ALIGNMENT NEEDS

The present section system level alignment and stability requirements .

#### 3.1 Alignment needs wrt pointing budget

The alignment allocations with regards to pointing budget are described in [AD3], and are reported hereafter

The following hypotheses are taken:

- In orbit, PACS LOS will be calibrated, and the SPIRE and HIFI LOS will be derived by analysis. Peak-up procedure data will be downloaded to ground.

SPIRE and HIFI positions and orientations in telescope focal plane will be measured/analyzed with regards to PACS ones.

##### 3.1.1 LOS

###### 3.1.1.1 PACS LOS

# Requirement derived from AD3

To allow a proper calibration in-orbit, the maximum misalignment between PACS LOS and STR LOS shall be less than 0.47 degree maximum(requirement include ground error sources and in orbit effects [gravity release, launcher effects...]).

###### 3.1.1.2 SPIRE and HIFI LOS

# Requirement

The SPIRE (resp. HIFI) LOS shall be known with regards to PACS LOS with an accuracy better than +/-3.6 arcsec each axis (Y, Z) 1sigma (requirement include ground error sources and in orbit effects [gravity release, launcher effects...]).

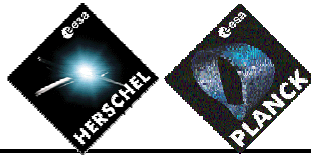

### 3.1.2 around LOS

#### 3.1.2.1 around LOS alignment knowledge

# Requirement

For each instrument, the Around LOS misalignment knowledge with regards to the H-PLM/SVM interface shall be less than 0.5 arcmin at 68% confidence level.

Nota: the contribution of SVM to around-LoS alignment is included in the SVM pointing requirements RD1 To illustrate this requirement, the PACS instrument is taken as an example. It's nominal field of view, depending on the mode (photometer mode or spectrometric mode), as projected in the sky by the telescope, is the following (units in degrees):

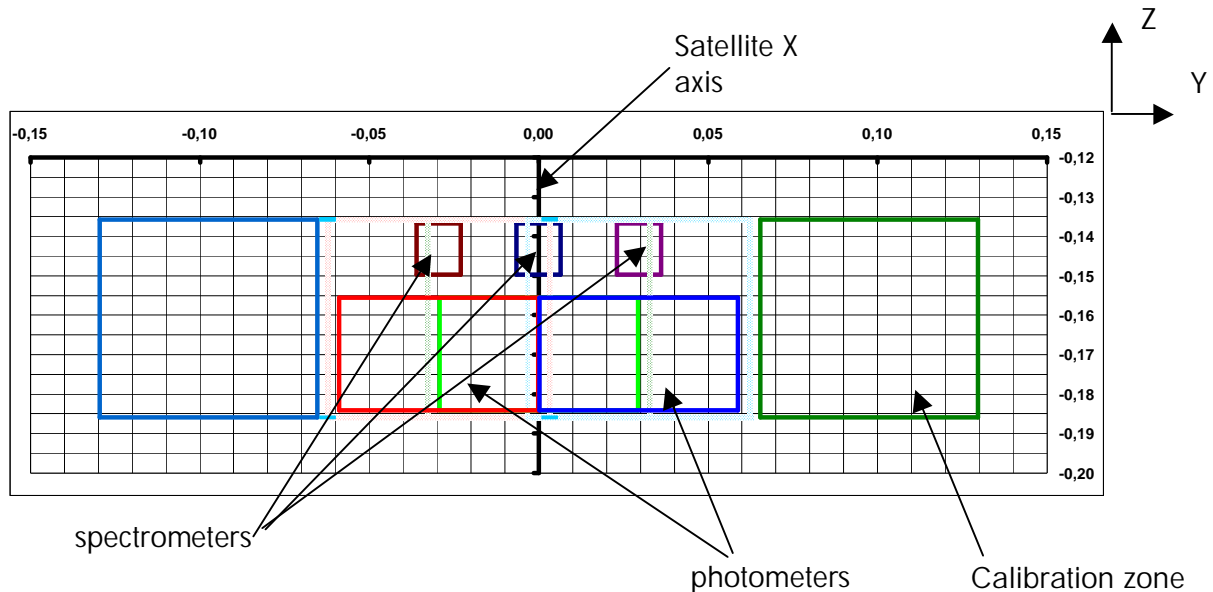

The angle between this FOV orientation and Y satellite (nominally 0dg), quantifies the PACS around LOS.

#### 3.1.2.2 Around-LOS Alignment

During operations, if the orientation of an instrument FoV around X is too much misaligned with regards to its theoretical orientation, there could be a conflict between

- pointing needs , which would impose a roll around X
- protection against sun illumination

In order to avoid this, the following requirement is needed:

# Requirement

The maximum around-LOS alignment bias of each instrument with regards to PLM/SVM interface shall not exceed 12 arcmin (including on ground positioning accuracy, thermoelastic behaviour,...).

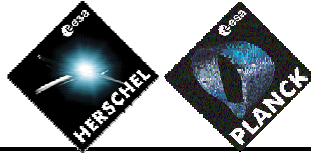

### 3.2 Alignment needs wrt thrusters

The 20 N thrusters are used for orbit correction and maintenance (see MISS 095, SPER 045). ).

"A" thrusters **exhaust directions** are ideal aligned with the average Spacecraft centre of Gravity. Herschel CoG may vary during lifetime of [50, 1, -6] mm (latest budget).

"C" thrusters **exhaust directions** are not aligned with regards to the CoG, but are used to create torque around any axis.

# Requirement

Taking in account thruster accommodation (typically in the order of 2 meter from centre of mass), the alignment accuracy between the thruster push axis and the BOL S/C CoG shall be better than 0.5°.

( $2 \cdot \sin(0.5^\circ) = 1.7$  cm representing around 20% of center of mass variation)

# Requirement

The thruster adjustment range shall be large enough to cover the difference between the theoretical CoG and the actual one at BOL.

Each one of the "A" thrusters shall be aligned with regards to the satellite CoG.

<sup>1</sup> the referred CoG is the one at a given time of the mission, i.e. with given fuel and helium filling ratios, not **exactly** the spacecraft CoG at the time of the measurement test

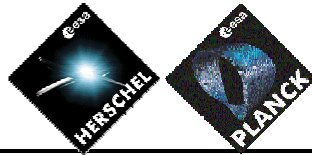

### 3.3 alignment needs wrt image quality performance

The two following requirements include the FPU and Telescope alignment performance

#### 3.3.1 focus

the telescope focus shall match axh instrument focus to the following accuracy (as per SRS [AD1])

	PACS	SPIRE	HIFI
Defocus	+/-7mm	+/-7.7mm	+/-8.5mm

#### 3.3.2 pupil mismatch

the instrument pupil shall match Telescope M2 with the following accuracy

	PACS	SPIRE	HIFI
Pupil mismatch	+/-7mm	+/-9.5mm	+/-24mm

Note that for these two preceding requirements, PACS is the driver. This is because PACS has the smallest wavelength range.

### 3.4 HIFI FPU to LOU alignment and stability

The two following requirement do not cover any LOU or FPU internal contribution

#### 3.4.1 Absolute alignment

Absolute alignment requirement between HIFI LOU and HIFI FPU are

	Dx	Dy	Dz	qx	qy	qz
LOU to FPU absolute	+/-0.75mm 1)	+/-15	+/-0.75	+/-0.038deg	1)	0.038

1)  $\theta_y$  impact included in  $\Delta x$  requirement

#### 3.4.2 In-orbit short term stability

alignment stability requirement over 100s between HIFI LOU and HIFI FPU are

	Dx	Dy	Dz	qx	qy	qz
LOU to FPU stability	+/-0.075mm /100s	+/-0.003mm /100s	+/-0.075mm /100s	+/-0.003deg /100s	+/-0.04deg /100s	+/-0.003deg /100s

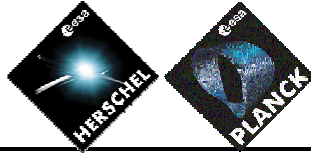

## 4. EQM/STM CAMPAIGN

this section presents the EQM and STM campaign, as far as alignment is concerned. It presents the alignment activities performed, (at PLM, SVM and S/C level) and the lessons learnt in view of FM

### 4.1 EQM campaign

#### 4.1.1 objectives

The EQM campaign – at PLM level only – was lead to perform performance measurement of QM FPU in a cryostat representative of Herschel FM (indeed a refurbished ISO cryostat)

#### 4.1.2 alignment activities

In that frame, LOU and FPU had to be aligned one wrt each other, using theodolites as measurement tools., and LOU struts as adjustment

#### 4.1.3 lessons learnt

Two lessons learnt concerning alignment: (see [RD15])

- confirmation of LOU adjustability via LOU struts length adjustment
- need of a specific MGSE during LOU adjustment to prevent LOU struts tensions

### 4.2 STM campaign

#### 4.2.1 objectives

The general objective of the STM campaign was to qualify the mechanical and thermal behavior of the S/C. For what concerns alignment, the objectives were

- verify the stability of the alignment before/after mechanical
- verify the stability of the alignment during cryostat cool-down
- verify the cubes accessibility, and more generally the alignment measurement methodology



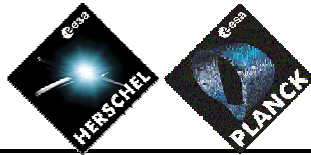

### 4.2.2 alignment activities

The alignment activities flow are synthetized in the following chart:

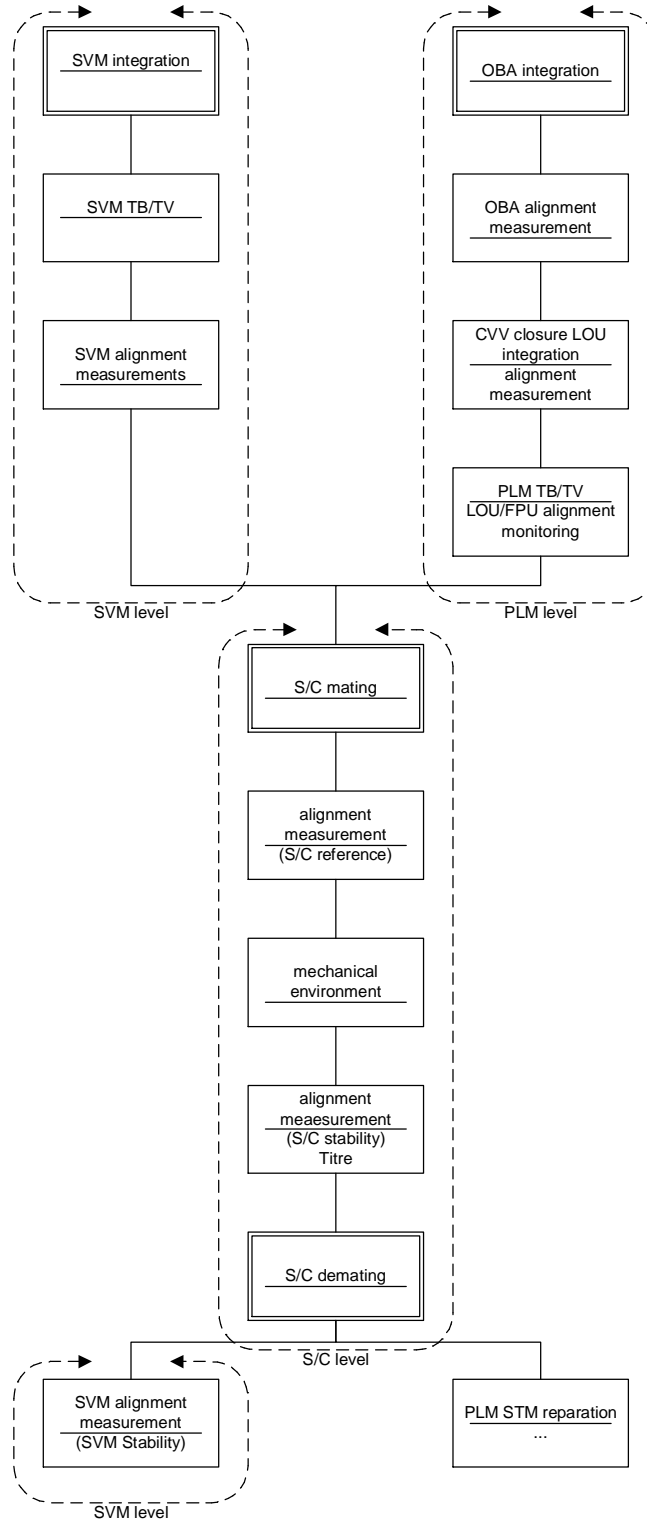
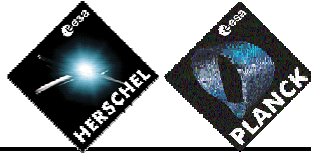

Figure 4-1 STM alignment activities sequence



4.2.2.1 at SVM level (see [RD13])

SVM units were integrated, and their alignment (orientation only) were measured wrt MRC3 and reported. In addition, the following was checked

- Thruster adjustment range capability
- Impact of opening/closing panels
- MRC1/2/3 stability wrt LVA ring clamping

4.2.2.2 at PLM level

before CVV closure, the location of the OB with regards to CVV was measured on the rotary table via theodolites (see [RD14]). The OBA was integrated in its nominal position in focus (X) and within 2mm in the plane (YZ)

FPU cubes visibility has been checked according to PLM alignment plan (see [RD3] and [RD16])

After CVV closure, the location/orientation of FPU wrt LOU have been measured (see [RD16])

- before CVV internal cool-down
- after CVV internal cool-down
- after straps re-tensioning

for information, the following graph shows the co-orientation of FPU wrt LOU during PLM integration (before cryostat cool-down is set to 0 (reference status))

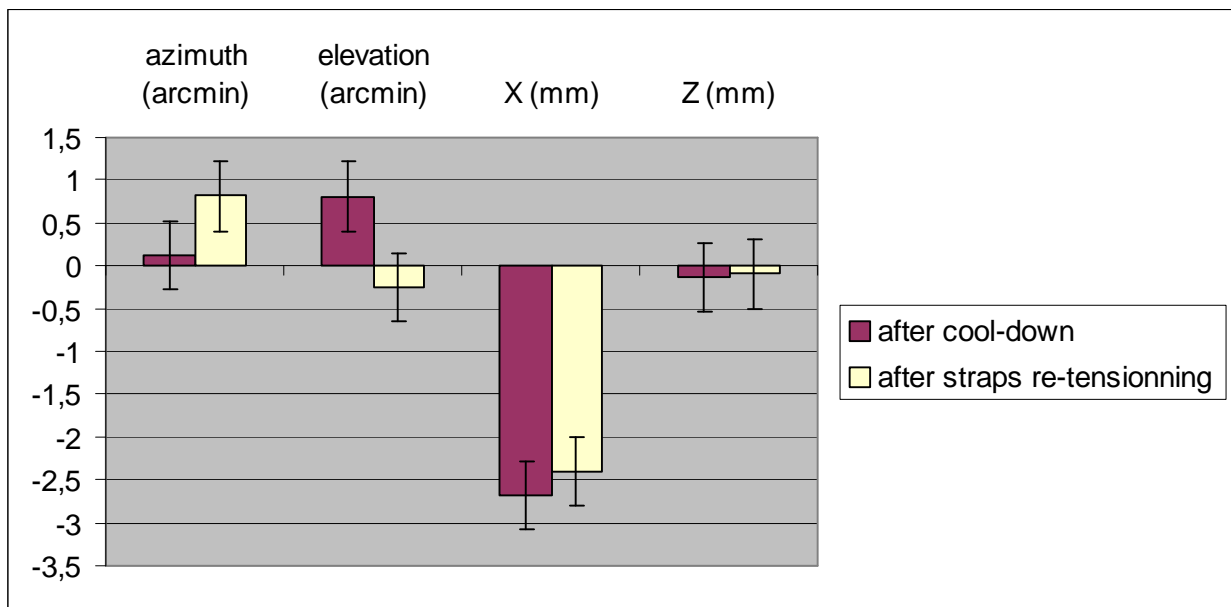
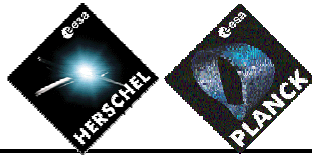

Figure 4-2 stability of FPU wrt LOU during PLM integration -> main effect is cool-down along X



During cool-down, the location/orientation of LOU wrt HIFI FPU was monitored by HACS (see test report [RD17] and final conclusion in MQR collocation [RD18])

The following graph shows the main result, which is the LOU to FPU alignment stability from ambient/ambient – to cold/cold conditions

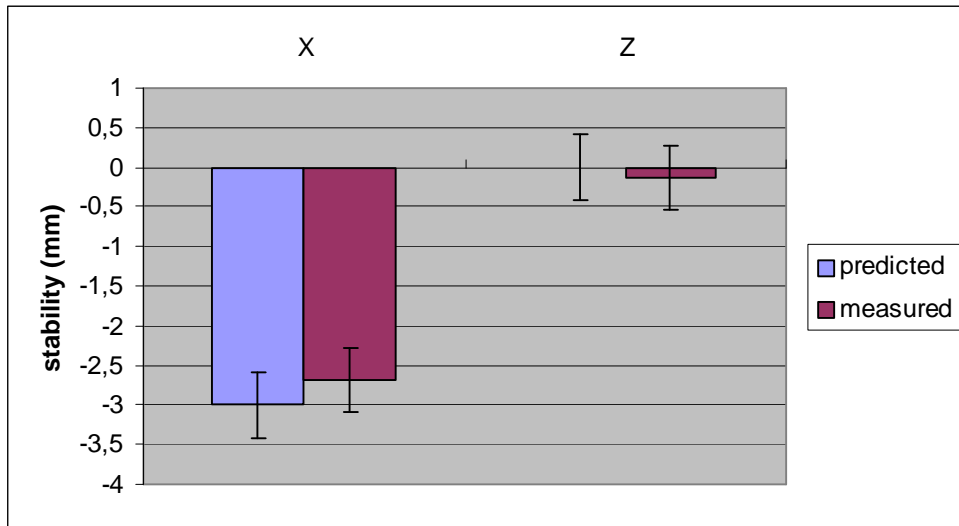
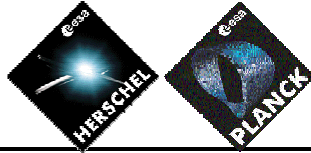

Figure 4-3 FEM correlates well the LOU to FPU stability from warm/warm conditions to cold/cold conditions

#### 4.2.2.3 at S/C level (see [RD12])

alignment reference measurement before and after mechanical environment after demating, SVM internal cubes alignment measurement



## 4.2.3 lessons learnt

### 4.2.3.1 hardware alignment and stability

LOU integration: the impact of HACH integration on LOU /FPU alignment to be monitored via theodolite (see [RD20])

PLM tank straps retentioning has small effect on translations. The effect on rotations, around 50arcsec, is still within LOU to FPU alignment budget. And will be monitored on FM  
good correlation between CVV thermoelastic FEM (between ambient/ambient and operational conditions) and HACS measurement.

SVM measurements confirmed that MRC3 is more stable than MRC1 and 2 wrt clamping.  
MRC4 was not accessible because MLI obstructed it. On FM, a specific tube guided by "Omegas" will be used. See principle in Annex 2.  
Sigraflex integration (on SVM ACMS and warm units) to be improved for SVM FM (see NCR 2582 [RD23])  
Opening/closing the panel possibly changes the alignment (more than the margin in SVM alignment budgets), so that alignment measurement on the panel should be done each time a panel is opened and closed. (see NCR 2583 [RD24])

CVV+TMS+LOU+STR+OBA are stable one wrt each other before/after mechanical tests (see [RD12] and [RD21])

SVM cubes less stable, still within the SVM alignment performance budgets (see NCR 2582 [RD23])  
thrusters alignment tool axis can be measured on-axis instead of the nominal use of lateral cubes sides. It leads to the same LOS. This helps saving time.

### 4.2.3.2 measurement method

#### 4.2.3.2.1 LOU AD to LOU PPB

difference of alignment reference between HIFI and ASED clarified for FM (refer to [RD19])

#### 4.2.3.2.2 HACS

sensitivity of HACS measurement to cross hair on the PPB clarified (see [RD16])

#### 4.2.3.2.3 S/C angular measurement by theodolite

The STM measurement campaign suffered from the fact that the angular transfer prisms (azimuth references) moved, and this was not noticed.

For FM

- Either the classical "two theodolite approach is followed" (as described by AAS-I in RD 1.1), which directly refers to the reference cube without intermediate reference -> instability risk is eliminated
- Or the movement risk is mitigated by a systematic check, before and after each measurement epoch (so 4times each day) of all the references. This check (date/time and result) should be reported in the as-run.

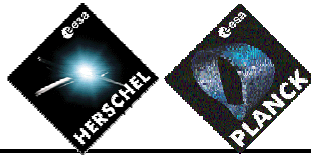

#### 4.2.3.2.4 Distance measurement method

On S/C STM, distance measurement method failed (as traces ion NC-2581 [RD22]).  
For FM, it shall be re-qualified (on-going action on ASED side AI#1 of RD6.1)

#### 4.2.3.3 data post process

For FM, matrices and stabilities will be computed online, in order to detect very quickly possible measurement errors

Expected raw data (especially for distance measurement) shall be included in the as-run, in order to check on the spot that there is no big error in the measurement

#### 4.2.3.4 hand copying errors

On STM, the data were

1. read on the theodolite
2. copied on a book (one book per operator)
3. copied again in the as-run

Finally, during data process, there are some doubts about some raw data,

For FM, we recommend the use of theodolite transferring directly the data to the PC, so that hand writing errors are avoided

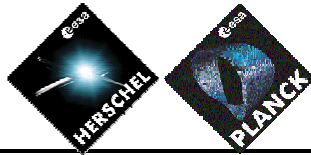

### 5. FM ALIGNMENT SEQUENCE

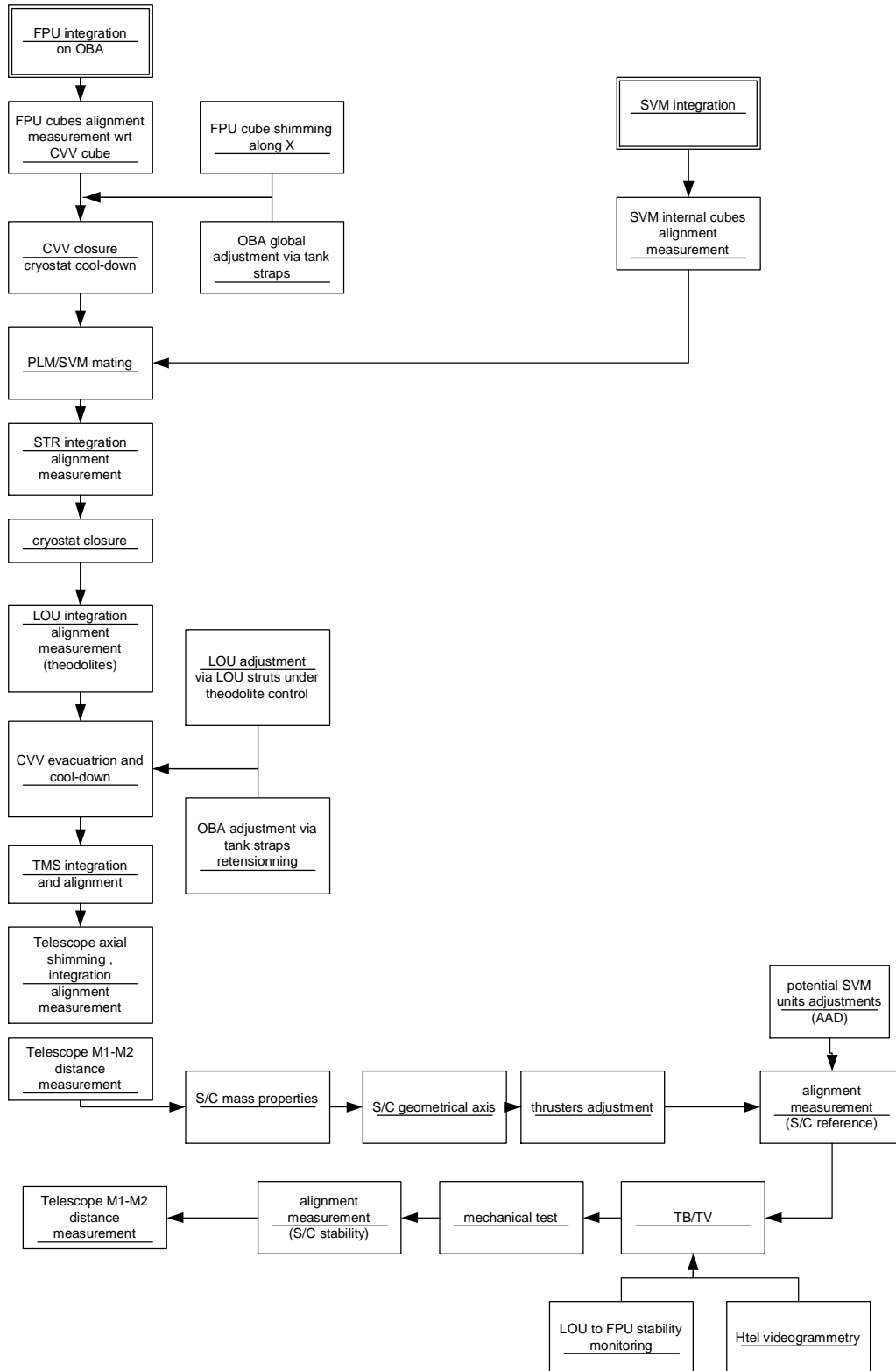
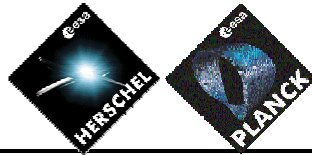

Figure 5-1 FM alignment flow



## 5.1 SVM alignment measurements

at SVM level before delivery, only internal cubes are measured with regards to external cubes. The goal is to avoid the necessity of opening the SVM panels at S/C level. It concerns:

- RWL wrt RWLref cube
- CRS wrt CRSref cube
- GYR wrt GYRref cube

See annex 1 for detailed view of the corresponding LOS

At that stage, the co-alignment of CRS (one wrt the other) and of RWL (one wrt the others) can be checked. No adjustment is foreseen at this level.

The rest of the alignment measurements and adjustments are done at S/C level.

## 5.2 Alignment sequence at H-PLM level

This alignment sequence is described in the Herschel PLM alignment plan [RD3] and schematically presented in the [Figure 5-1](#).

The following adjustments are available (if necessary)

- FPU axial adjustment wrt OBA  
for focus only  
for each FPU (except SPIRE) shim between FPU and OBA  
+/-3mm shimming capability is available
- OBA 3 axis adjustment wrt CVV  
for focus and pupil mismatch  
this is done by tank straps adjustment under theodolite control (as on the STM)  
+/-1.5mm adjustment capability each direction is available
- LOU 3 axis adjustment  
for HIFI FPU to LOU alignment  
this is done by LOU struts adjustment under theodolite control (as on the EQM)  
+/-3mm (resp +/-2.5mm) adjustment capability is available in X (resp. Y and Z) directions
- TMS integration  
for focus and pupil mismatch  
TMS frame is put at the correct location wrt CVV via MGSE, and the TMS struts are adapted in the 3 directions  
2mm in radius adjustment capability is available, and +/-1.6mm is available along X
- Telescope shim:  
for focus only  
between telescope bipods and TMS frame;  
shim of +/-5mm shimming capability is available.  
there is a mechanical analysis on-going to check if a shim of 8.6mm is acceptable, in view of compensating the telescope cryo-defocus as per [RD25]

Note that there is a priori no need for shimming in view of PACS LOS alignment requirement. This will however be kept under control during PLM alignment.

Main open point for FM metrology is the distance measurement method, which has to be re-qualified by ASSED. This action is currently ongoing

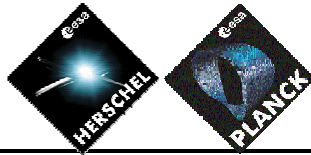

The most critical operation is the telescope integration on the TMS. Especially in view of the criticality of the flatness of the interface. A non flat interface could induce stresses during integration, and therefore a residual deformation of the M1 surface after Telescope mating. This point has been addressed at the Telescope QR [RD29]. The requirement is 100 $\mu$ m in total with 80 $\mu$ m on TMS side and 20 $\mu$ m on Telescope side. Based on CASA experience, we have good confidence that the TMS will be within spec. On Telescope side however, even if no RFW is raised yet, the budget has to be clarified, and a RFW should be raised for this aspect (see [RD29]). Because of the revised non-planarity budget and the impact on the telescope WFE and because of difficult knowledge of real planarity before mating, ASEF and ASER will define the necessary precautions to be followed before and during Telescope integration.

Note that

- FPU alignment is done before cryostat closure and PLM cooling,
- some PLM alignment activities are done after PLM/SVM mating (e.g. LOU and tank straps adjustment, Telescope integration).

### 5.3 Alignment sequence at Herschel satellite level

#### 5.3.1 alignment sequence

The alignments activities sequence is shown in [Figure 5-1](#)

#### 5.3.2 alignment objectives

The objectives of the alignment activities at S/C level are

- provide the alignment data of ACMS sensor wrt launcher IF (geometrical reference frame) and STR wrt PACS (PACS being embodied by CVV reference cube) (possibly re-align some units if necessary, but it is not nominal) covered by the alignment specification TS-0920 (see [RD9]) and mechanical axis determination test specification (see [RD26])
- verify the stability of alignment before/after environmental test campaign (mechanical and thermal) covered by the alignment specification TS-0920 (see [RD9]) and mechanical axis determination test specification (see [RD26])
- verify the correct alignment at cryo (in TB/TV) of LOU wrt FPU (HACS) and Telescope (videogrammetry) covered by the TB/TV test specification and specific H-PLM specifications
- align the thrusters exhaust directions onto the CoG covered by the thruster alignment specification (see [RD27]), to be issued
- Measure M1-M2 distance: the objective is to check the stability of M1-M2 distance before/after S/C environment. Measurement done at S/C level will be compared with the reference done at Telescope level.



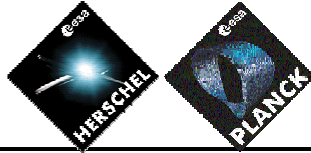

For stability reason, the satellite reference cubes are mounted on the top of the SVM:

AC1 is also called MRC4 and AC2 is also called MRC3

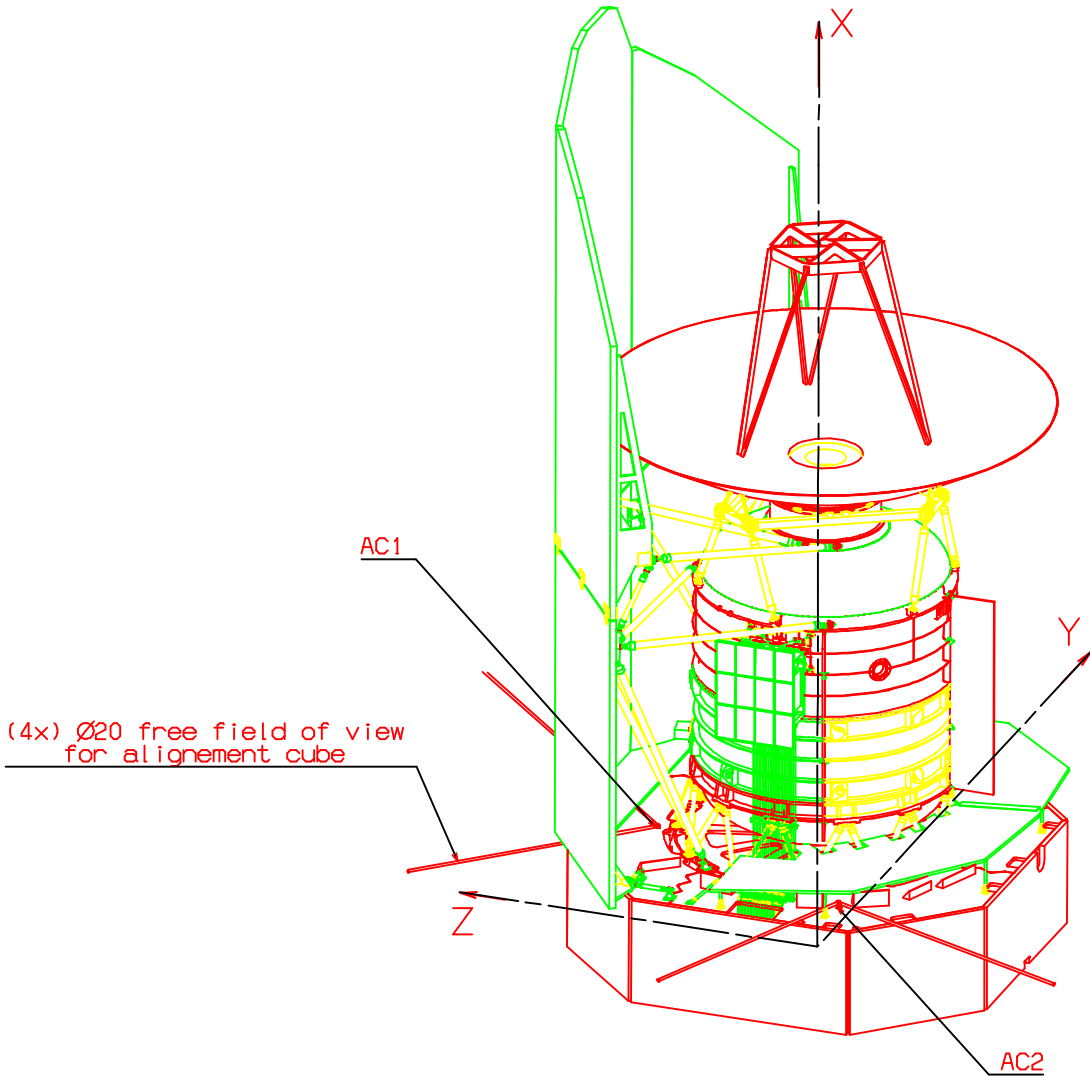

accessibility of AC1 (MRC4) at S/C level is quite difficult, so that a specific tool has been designed, as described in annex 2

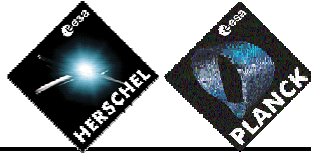

### 5.3.3 spacecraft mechanical axes determination (see [RD26])

This operation will provide the orientation of the launcher Interface in the spacecraft alignment cubes coordinates.

This is used as an intermediate reference for thruster alignment on CoG, and is also part of ACMS units alignment characterization.

The measurement principle is the following:

The contour of the LVA ring is measured with a mechanical finger, and the plane orientation is referenced with regards to the spacecraft optical references

On the LVA ring, two marks are made to define the Z and Y axis. Each axis are defined by the center of the LVA ring measured circle and the mark.

### 5.3.4 Spacecraft alignment measurement and alignment checks (see [RD9])

The alignment between each subsystems are firstly measured after mating (this allows to have the reference), and then checked in the following way . Theodolites are used.

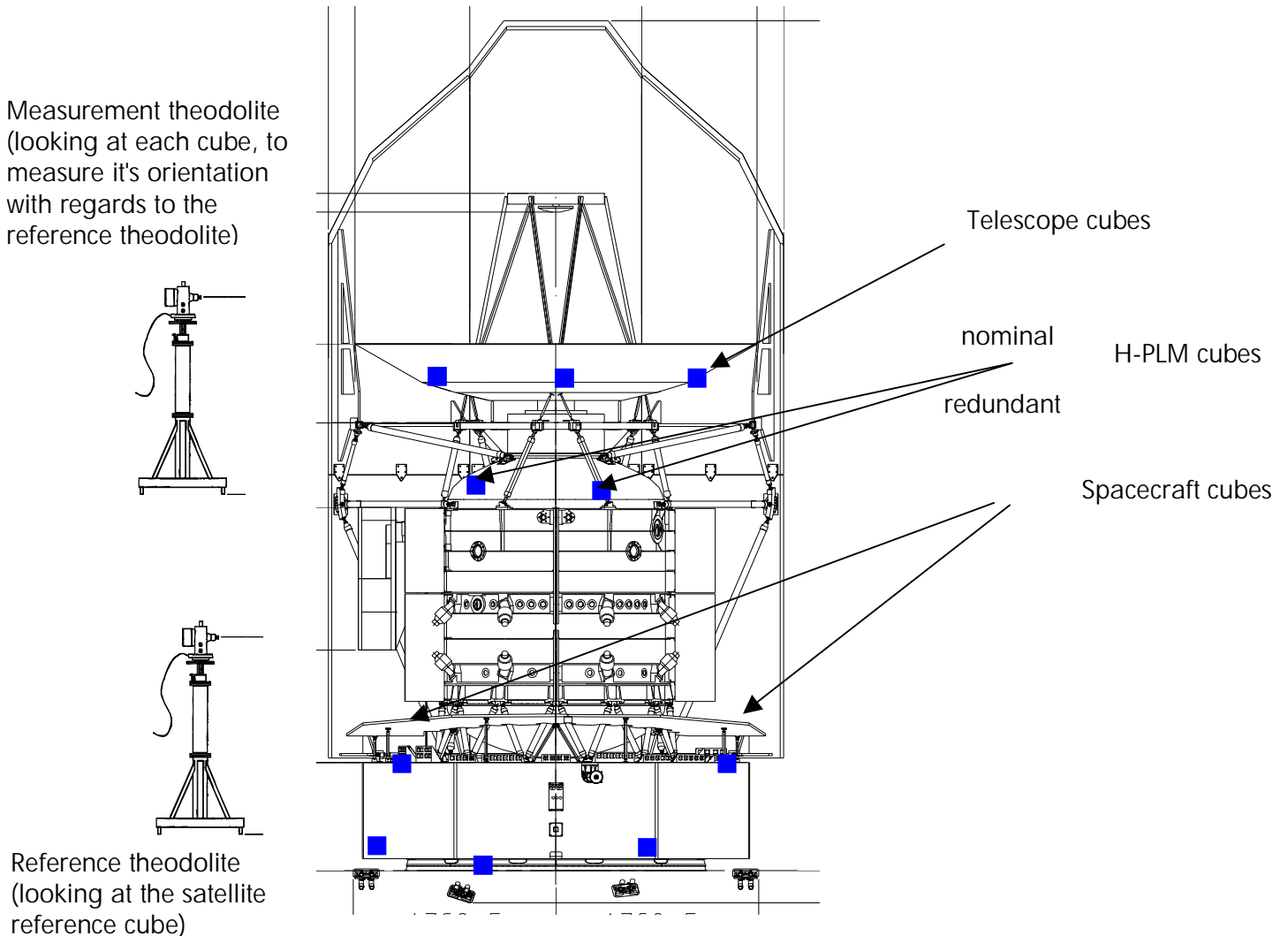

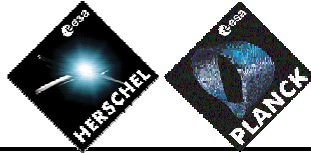

The optical cubes to be looked at are the following:

Element		Optical cubes quantity	Nominal LOS
H-PLM See [RD3]	telescope	4 cubes with reticules (2 nominal, 2 redundant)	2
	TMS	1 cube	2
	CWV	2 cubes with reticules (1 nominal, 1 redundant)	2
	LOU	ventlines 2	3 2
SVM see [RD6]	SVM reference	2 cubes (1 nominal, 1 redundant)	2
	External Thrusters	12 cubes	24
	AAD	1cube	2
	Star Trackers	2 cubes	4
	Internal CRS	1cube <sup>3</sup>	2
	RWL	4 "cubes" <sup>4</sup>	4
GYR	1 "cube"	2	
Satellite		2 cubes	2

The LOS are described in annex 1.

<sup>3</sup> Indeed the two CRS will not be accessible for pointing at S/C level. Only the CRS reference cube will be accessible. This cube will have been referenced with regards to the two MRC's cube at SVM integration level

<sup>4</sup> Indeed 2 RWL LOS will be directly accessible via 2 holes on the SVM -Y +Z panel The two other RWL will not be accessible, only a cube, located on the external side of the RWL panel will be accessible. the link between internal RWL LOS and external cube LOS will have been measured at SVM level before delivery

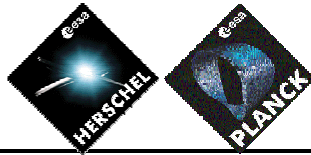

### 5.3.5 Thrusters exhaust directions alignment (see [RD27])

Based on the CoG knowledge, the four so-called "A-thrusters" will be aligned with regards to the best estimation of the satellite CoG in-orbit<sup>5</sup>.

The eight other thrusters – C –will not be aligned with regards to the satellite CoG

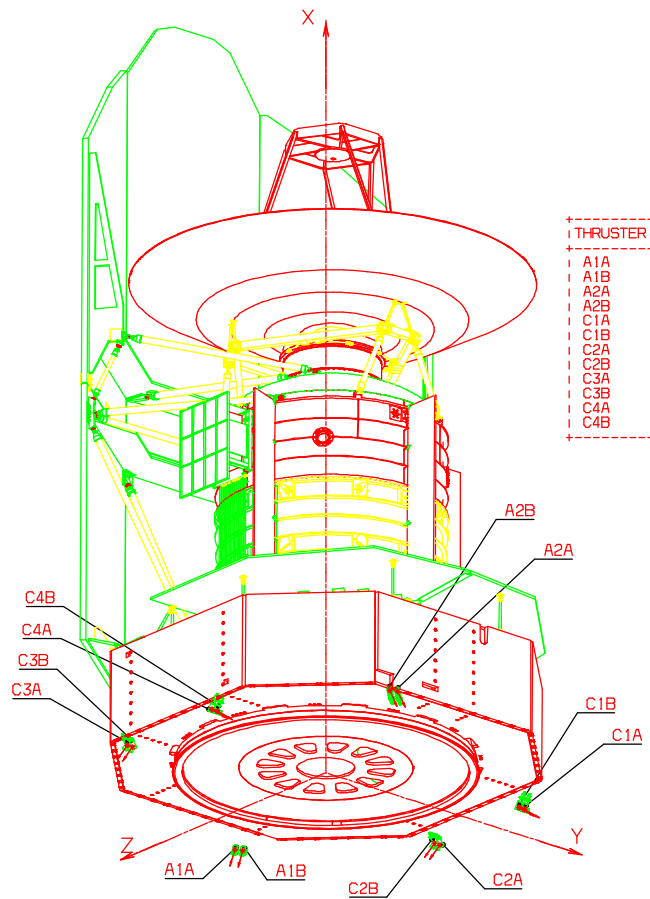

This alignment is based on classical theodolite measurements, and uses removable optical cubes located on the thruster nozzles. A 2° adjustment capability (rotations) is available on each thruster (see [RD10] thruster bracket user's manual)

<sup>5</sup> on the STM, only the alignment range capability will be checked

## 5.4 alignment measurements during TB/TV

two kinds of measurements done on the PLM in TB/TV:

- HACS measurement between LOU and FPU
- Videogrammetry for the telescope

### 5.4.1 HACS

The objective of HACS is to measure the co-alignment (translations and rotation) of LOU (embodied by a pentaprism block PPB)

This is a repetition of what was done on the STM

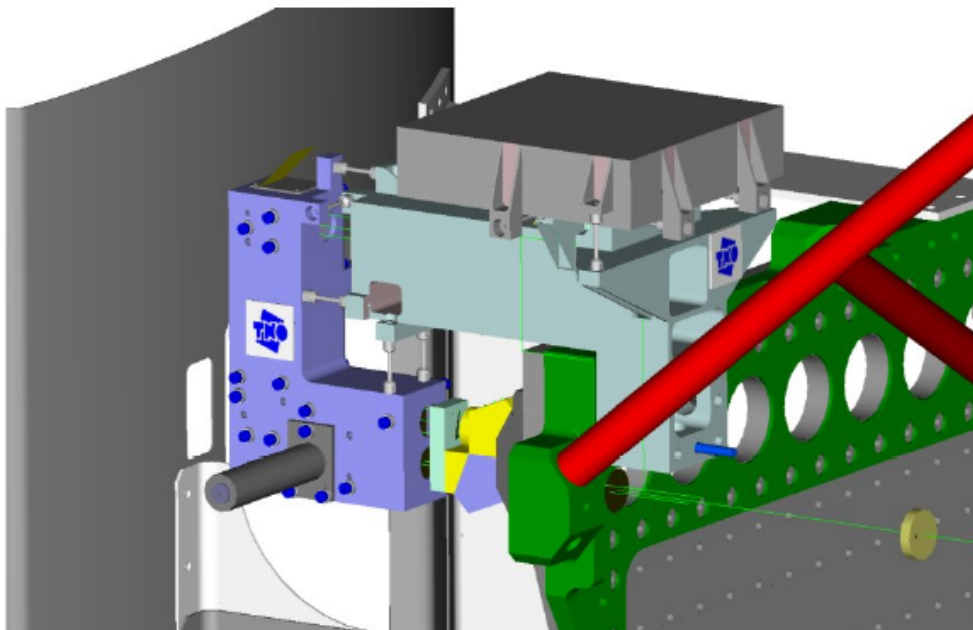

Figure 5-2 one camera HACS integrated on -Z side of LOU

This is a way to check the very stringent alignment for LOU vs FPU in quasi operational conditions.

### 5.4.2 Videogrammetry

The objective of videogrammetry is to control the Telescope displacement wrt CVV at cryo. This is a check of the thermoelastic model.

The principle is to have specific high resolution cameras with flashed in the clean room, which looks, from different positions some targets put on the telescope M1 rim and on the LOU. Each image provides 2D coordinates, and the sum of all the images from the same scene seen from different points of view permits to reconstruct the 3D cloud of points of the targets. A reference scale bar, put in the clean room in the cameras FOV is used to scale the cloud of point to the proper dimension.

The setup is not yet finalized. Here is a sketch of the setup currently foreseen

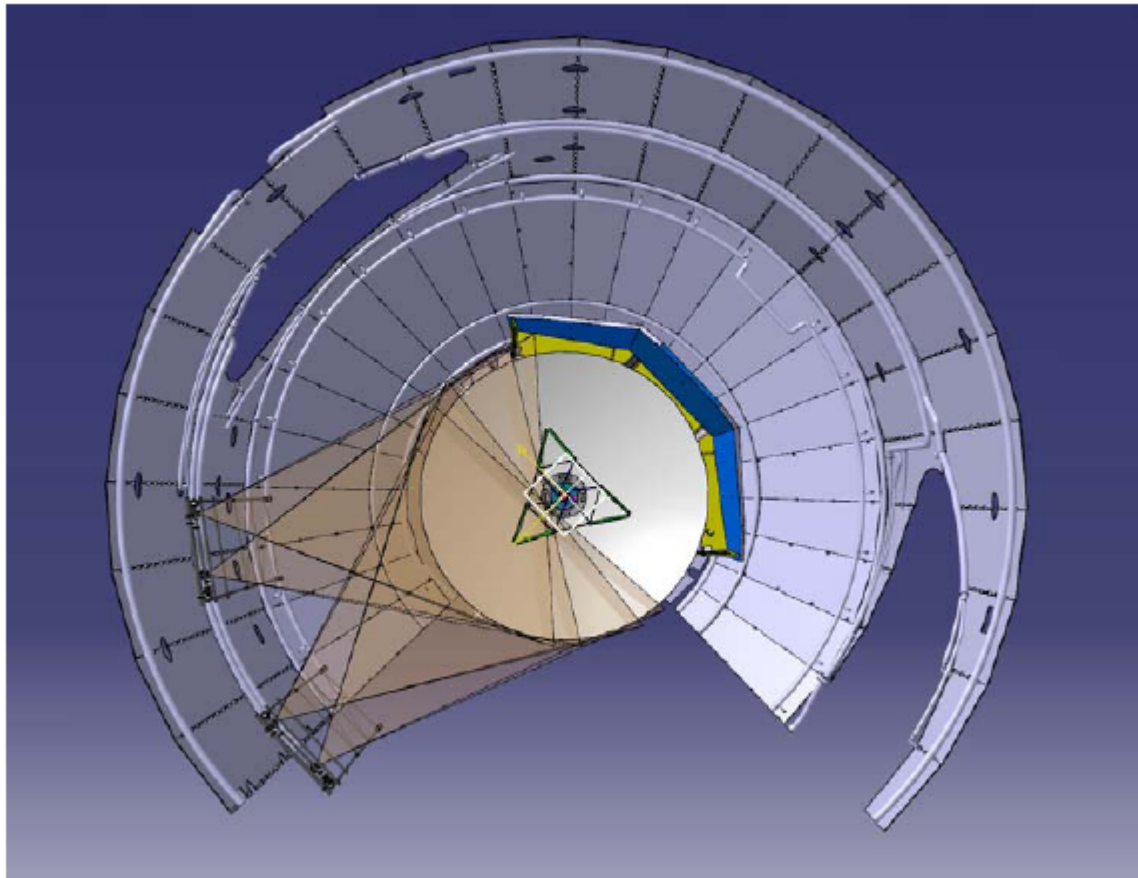
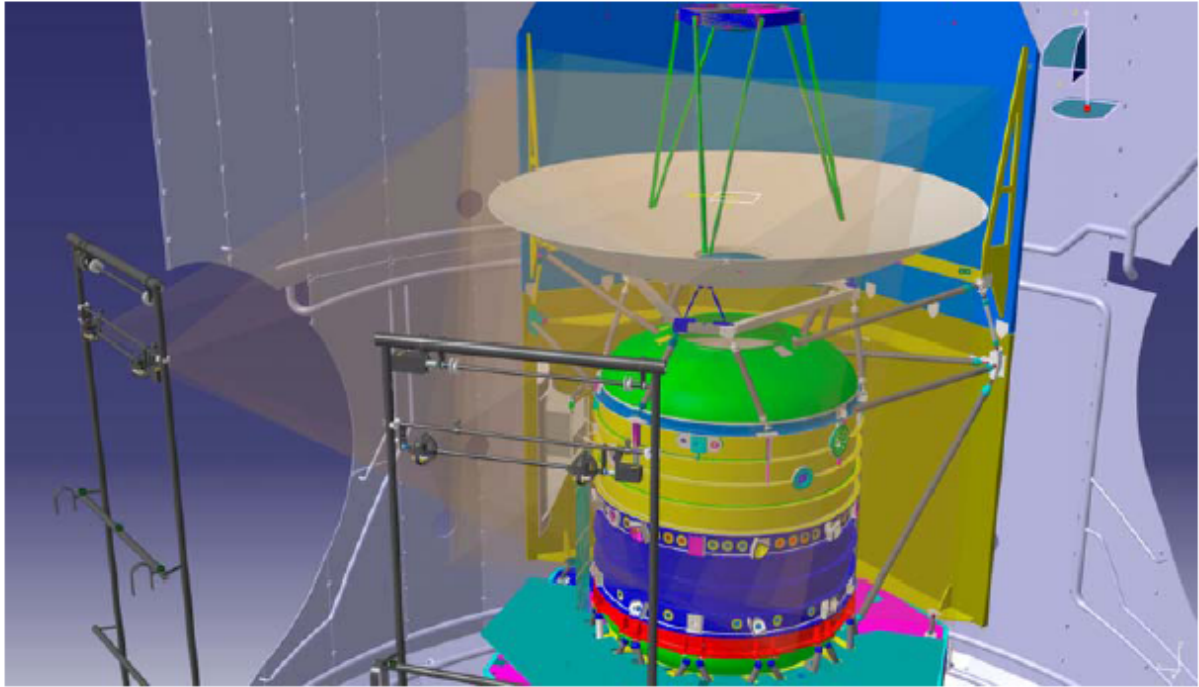
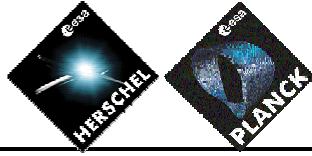

there are discussions on going concerning LOU visibility with or without CVW radiator. Three options are opened:

1. implement a target support plate to represent the LOU

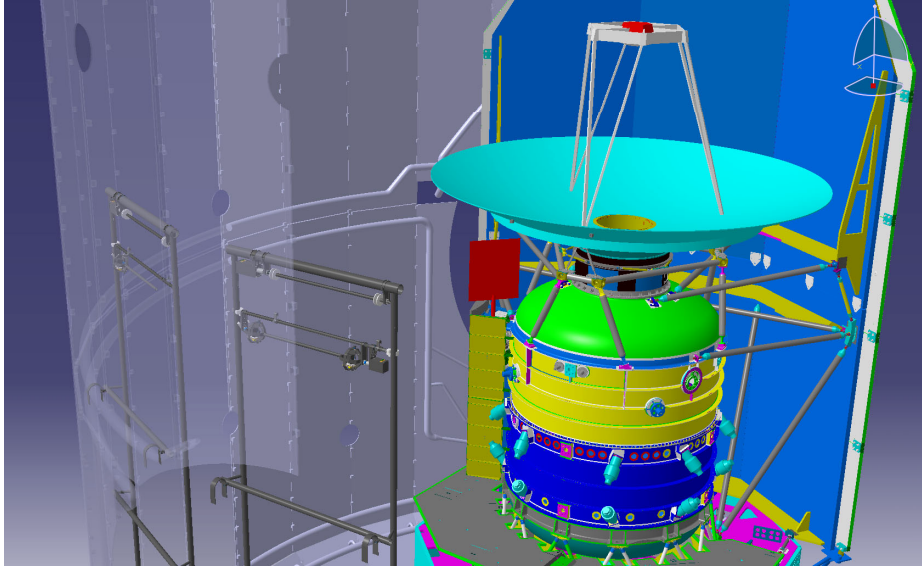

Figure 5-3 an extension is needed to « see » the LOU above the radiator

2. remove the CW radiator
3. put targets on the CW -Z side, and not on LOU

Trade off is on progress, to be finalized on 15<sup>th</sup> of March, 2007, as per working plan agreed in [RD 30].



## 5.5 Telescope M1-M2 distance measurement

The objective is to check the stability of M1-M2 distance before/after S/C environment. Measurement done at S/C level will be compared with the reference done at Telescope level.

Because of the very small M1 F/number (F/0.5), the telescope back focal length is very sensitive to M1-M2 distance. The  $\pm 25\mu\text{m}$  distance measurement accuracy requirement corresponds to  $\pm 5\text{mm}$  Telescope defocus.

The test principle is to measure the distance between corner cube reflectors: 5 on M1 and 1 on M2



Figure 5-4 corner cube reflector

Telescope has to be in horizontal position

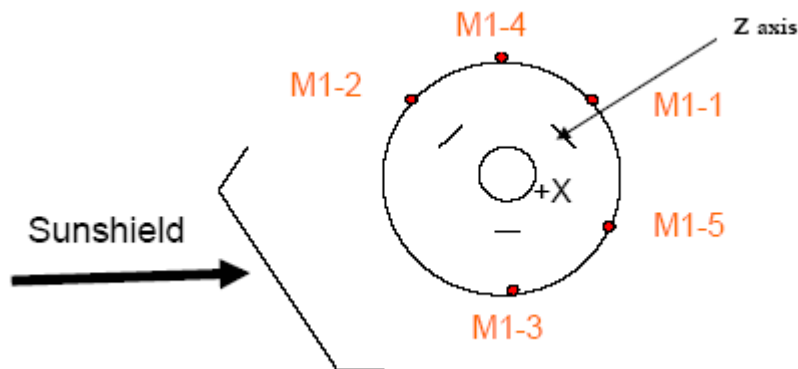
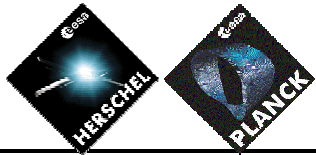

Figure 5-5 M1 Corner cube accommodation

The corner cube on M2 is rotated around M2 axes, so that 18 positions are measured. Finally, the distance measured at Telescope level before delivery is  $1194.270\text{mm} \pm 0.025\text{mm}$

The test is fully described in ASEF test report and test procedure [RD31] and [RD32]





## 6. SYSTEM ALIGNMENT CONTRIBUTORS ALLOCATIONS

PLM and SVM specifications contributors and allocation are described respectively in the SVM alignment plan and in PLM alignment plan. We focus here on the system specifications

### 6.1 contributions to alignment allocations with regards to pointing budget

#### 6.1.1 HPLM /Star – tracker LOS alignment

##### 6.1.1.1 Contributors to misalignment

The contributor's tree to the line of sight is thus the following:

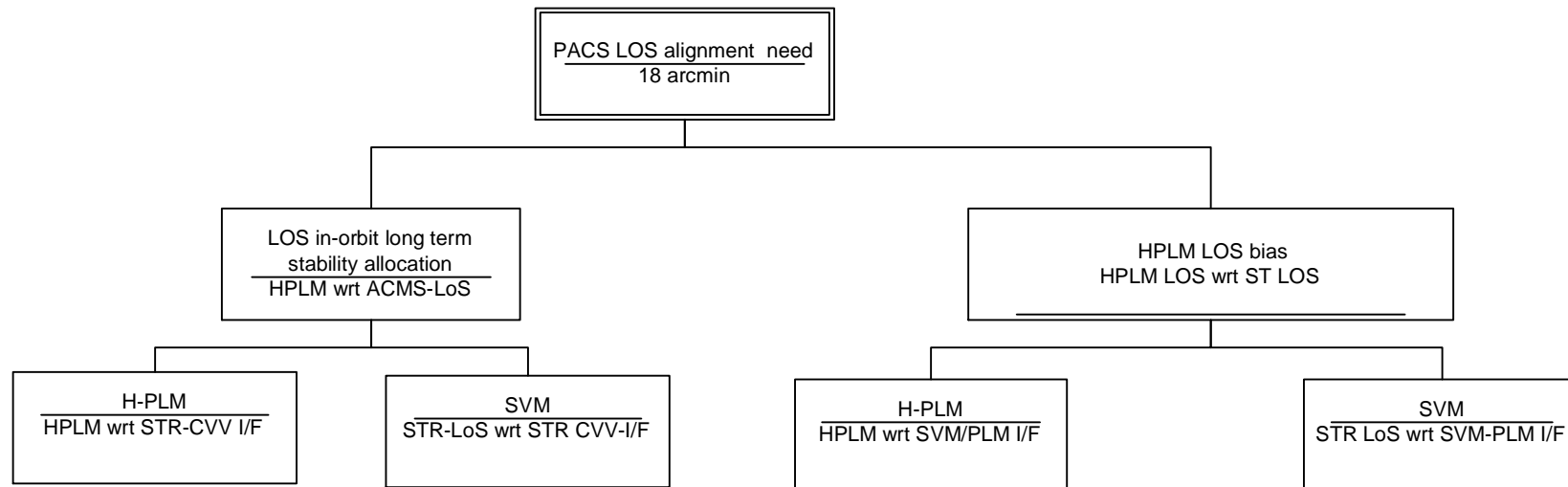

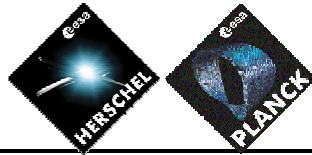

### 6.1.1.2 requirements associated to LOS misalignment

#### SVM internal stability:

The allocation to the in-orbit stability of the ACMS LoS with regards to the SVM-PLM interface Coordinate System is 1.15arcsec at 68% confidence level. This is in line with the long term stability requirement of ACP-050-H (cf [AD4])

#### HPLM internal stability:

The in-orbit HPLM LOS stability with regards to the star/tracker assembly is required to be less than 0.4 arcsec peak-peak around Y (cf [RD4]), requirement number HERS-0700, and 0.2arcsec peak-peak around Z

As per Herschel telescope specification, the telescope LOS might be misaligned with regards to the mechanical IF of 10 arcmin

#### SVM LOS alignment bias

The in-orbit star-tracker LOS alignment bias with regards to the PLM/SVM Interface shall be lower than +/- 0.25deg half cone.

#### PACS LOS alignment bias

The PACS LOS alignment bias with regards to the PLM/SVM Interface shall be lower than +/- 5 arcmin half cone (including ground and in-orbit effects).

The following table gives the relevant contribution

Contributor		Contribution (worst case)
SVM	Bias	15arcmin
	stability	+/-1.15 *2<3.15each axis
HPLM	HPLM Bias	5arcmin
	Telescope	10 arcmin
	stability	< +/-0.2 arcsec each axis
TOTAL	RSS	<19arcmin

note: the STR platform design offers a shimming capability . This shimming capability will be used by ALS for their own purpose (AIT constraints, SVM alignment constraint). The spacecraft alignment does not need to use this shimming, as far as the modules requirements are fulfilled.

### 6.1.1.3 SPIRE/HIFI LOS knowledge

SPIRE and HIFI in-orbit LOS shall be known with regards to PACS LOS with an accuracy better than +/-3.6 arcsec each axis (Y, Z) at 1 sigma(including on-ground alignment knowledge, in-orbit stability knowledge..)

Contributor	Contribution	reference
HPLM	3.6arcsec	[RD4]

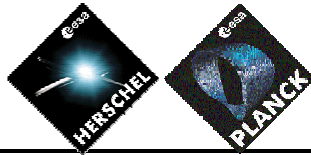

## 6.1.2 AROUND LOS-Allocations

### HPLM around-LOS knowledge:

The around-LOS alignment of each instrument with regards to the star-tracker assembly Interface frame shall be known with an accuracy better than  $\pm 0.5$  arcmin at 68% confidence level (including on-ground alignment knowledge, in-orbit stability knowledge...).

## 6.2 allocations to thruster plumes exhaust directions alignment

### 6.2.1 alignment accuracy – contributors

The alignment of the thrusters exhaust directions is performed at satellite level, after the location satellite CoG is known.

The contributors are thus the following

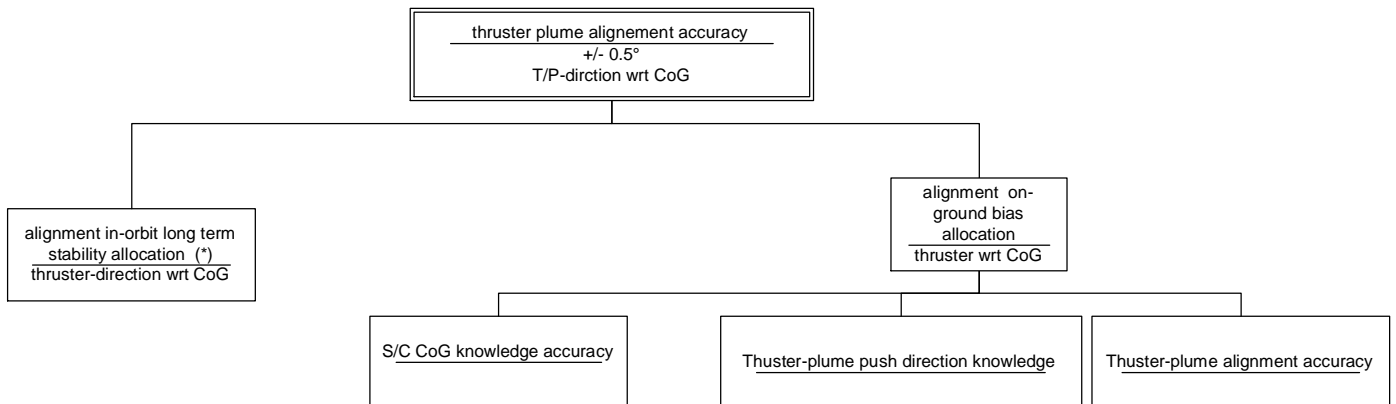

(\*) in-orbit CoG variation is not included in this contributor. It is included in the upper-level ACMS budget.

### 6.2.2 alignment accuracy-allocations

#### 6.2.2.1 allocations

The in-orbit alignment stability of the thruster together with its on-ground "push direction" knowledge wrt SVM I/F reference frame shall be less than  $\pm 0.25^\circ$ . This is a requirement on the SVM structure.

The alignment accuracy of the thruster exhaust directions plume with regards to the S/C-CS - at system level shall be better than  $\pm 3$  arcmin.

The Satellite CoG location on-ground knowledge accuracy shall be better than  $[\pm 14; \pm 1; \pm 1]$ mm in Satellite Coordinate system (fulfilled by [RD11]).

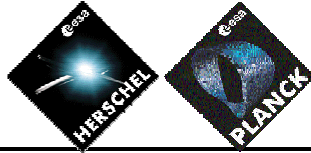

To translate this CoG knowledge accuracy into thruster exhaust directions alignment inaccuracy, the following sketch is useful (only the x inaccuracy is considered because it is the most important

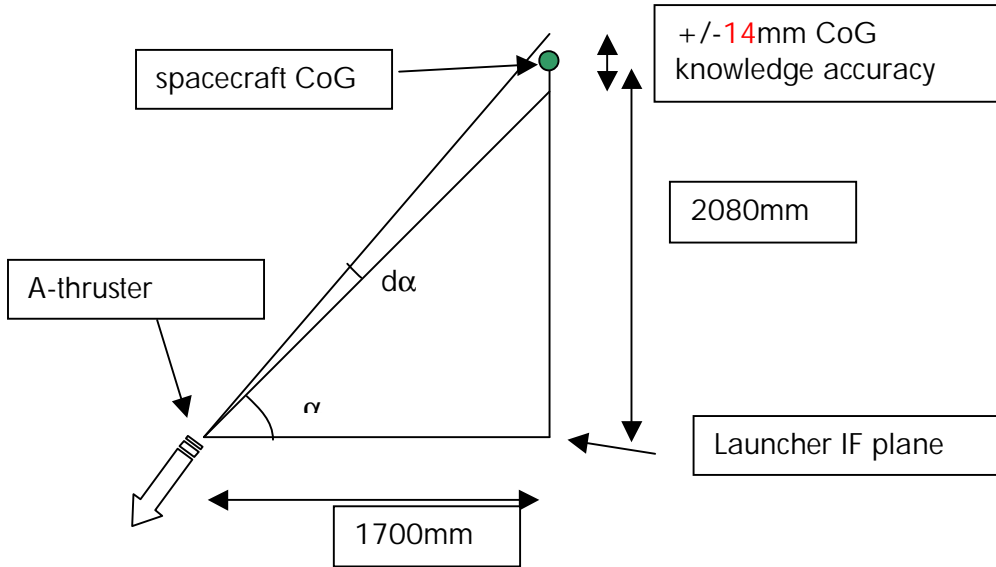

We have  $\tan a = \frac{2080}{1700}$  and  $\frac{d \tan a}{da} = 1 + \tan^2 a$  this gives

$$da = \frac{d \tan a}{1 + \tan^2 a} = \frac{14}{1700} \frac{1}{1 + \left(\frac{2080}{1700}\right)^2} = 3.3 \text{ mrad} \quad \text{i.e. } +/- 12 \text{ arcmin}$$

This corresponds to 12 arcmin

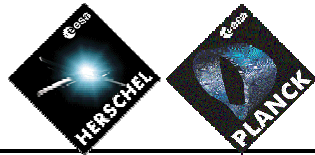

### 6.2.2.2 synthesis

	Contribution (arcmin)	Status
Thruster-plume knowledge & stability	+/-15	specified by Alenia
System level thruster-plume <b>exhaust directions</b> alignment accuracy	+/-3	Direct specification to AIT
S/C CoG on-ground knowledge accuracy	+/-12	Direct specification to AIT

### 6.2.2.3 thruster-plume **exhaust directions** alignment accuracy - budget

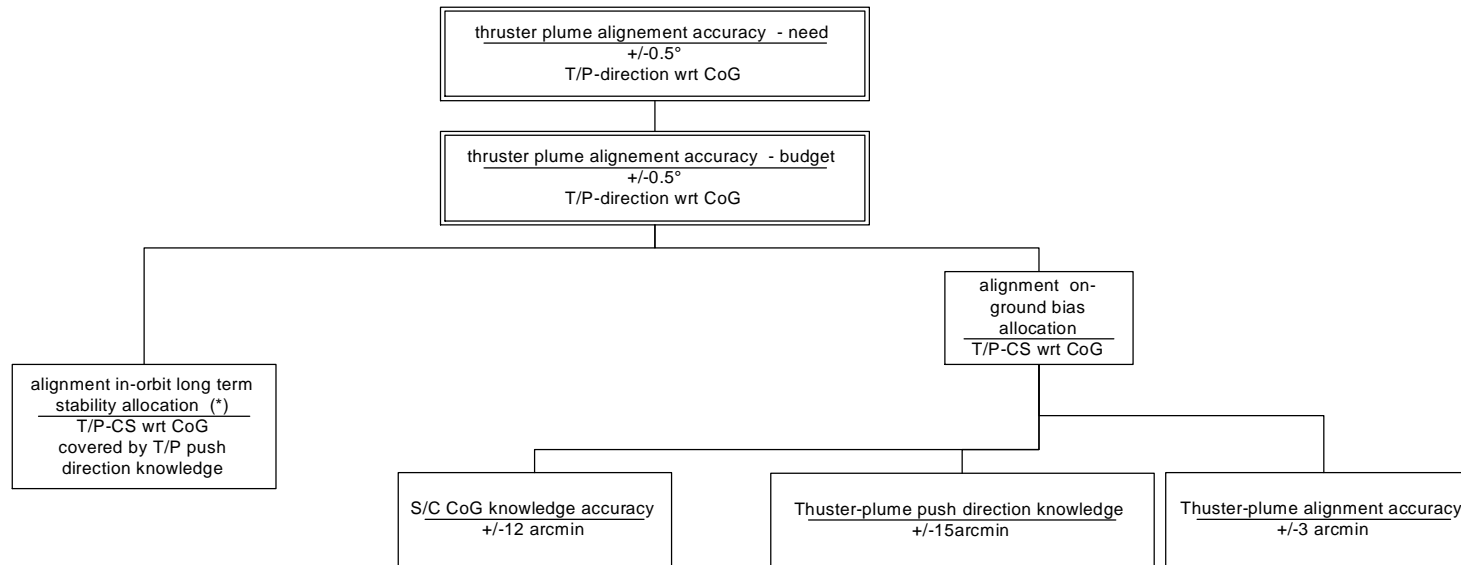

(\*) this shall not take into account the in-orbit CoG displacement.

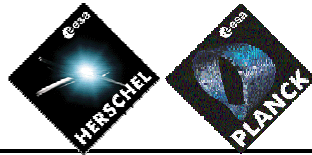

### 6.2.3 thruster plume adjustment range – contributors

the following tree represents the contributors to the maximum needed adjustment range for the thrusters at satellite level.

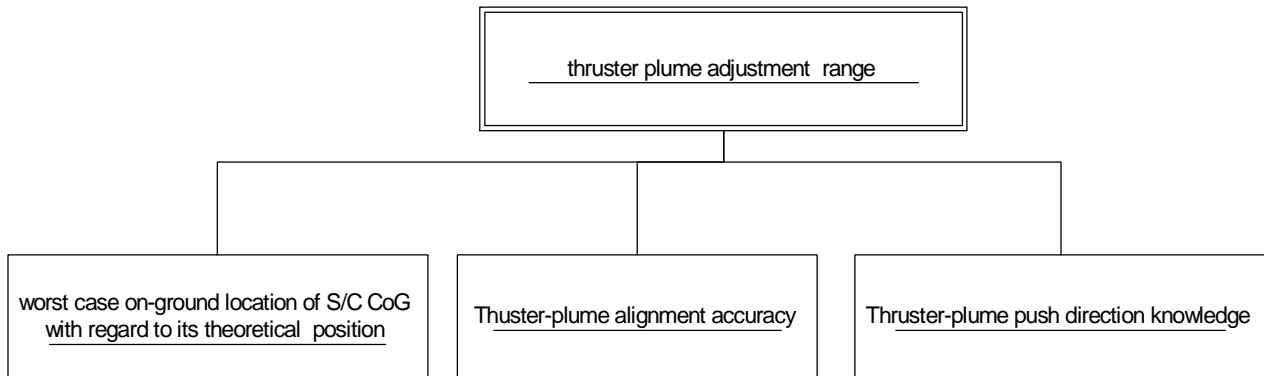

### 6.2.4 thruster plume exhaust directions adjustment range – allocations

#### 6.2.4.1 allocations

The distance between the actual on-ground location of Satellite CoG and its theoretical position shall be less than +/-30mm. This corresponds to a +/-0.86° angular adjustment range.

The on-ground push direction knowledge accuracy shall be better than +/-0.25°. This corresponds to +/-8.5mm distance between thruster-plume push direction and CoG. This is covered by the alignment accuracy allocation.

The alignment accuracy of the thruster plume exhaust directions with regards to the S/C-CS - at system level-shall be better than 3 arcmin. This corresponds to 1.7mm distance between thruster-plume push direction and CoG. This is covered by the alignment accuracy allocation.

#### 6.2.4.2 synthesis

	Contribution	Status
Thruster-plume knowledge	< +/-0.25°	Specified by ASP (see [RD1] RCP-050-C)
System level thruster-plume exhaust directions alignment accuracy	+/-0.05°	State of the art with margin
S/C CoG on-ground worst case bias	+/-0.86°	

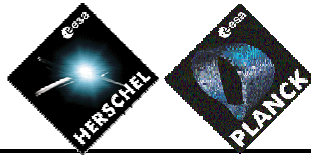

6.2.4.3 angular adjustment range for system alignment needs - budget

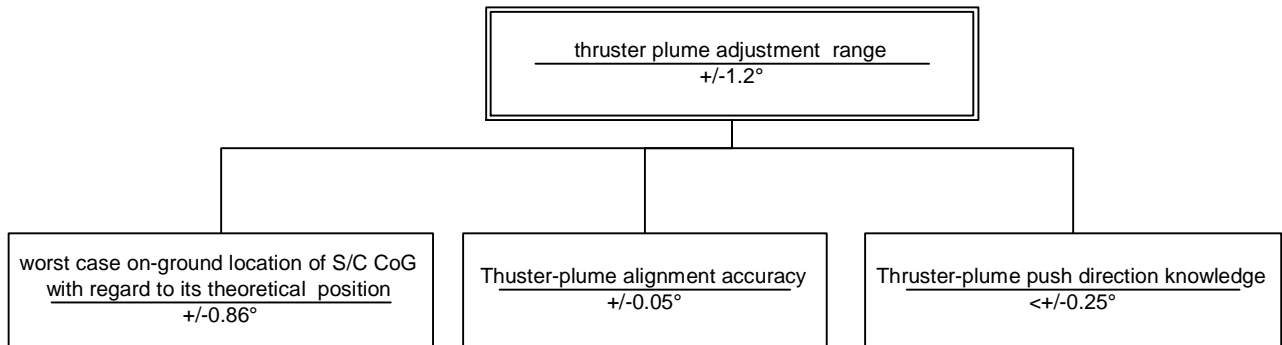

The agreed value for thruster adjustment with the RCS contractor is 2° half cone which is in line with the requirement.

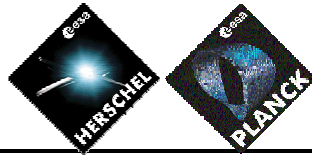

## 7. REQUIREMENTS

### 7.1 At H-PLM level

# Reformulated Requirement covered by HERS-0700

The in-orbit thermo-elastic stability of the PACS Line of Sight with regards to the star-tracker assembly Interface shall not exceed  $\pm 0.4$  arcsec peak-peak

#

# Reformulated Requirement HERS-0640

The PACS Line of Sight alignment bias with regards to the CVV/SVM Interface shall be lower than  $\pm 5$  arcmin (including ground and in-orbit effects).

#

# Requirement HERS-0650

SPIRE and HIFI in-orbit LOS shall be known with regards to PACS Line of Sight with an accuracy better than  $\pm 3.6$  arcsec one sigma each axis (Y, Z) (including on-ground alignment knowledge, in-orbit stability knowledge..)

#

# Reformulated Requirement HERS-0660

The around-LOS alignment of each instrument with regards to the star-tracker assembly shall be known with an accuracy better than  $\pm 0.5$  arcmin at 68% confidence level(including on-ground alignment knowledge, in-orbit stability knowledge...).

#

# Requirement HERS-0680

H-PLM will be equipped with at least 2 optical cubes (1 nominal, 1 for redundancy). They shall represent the H-PLM optical reference frame.

#

# Requirement

H-PLM cubes shall allow an orientation knowledge than 10arcsec in the three directions, and shall be accessible at system level, especially before and after the mating between H-PLM and SVM.

#

# Requirement HERS-0645

The maximum around LOS alignment bias of each instrument with regards to PLM/SVM interface shall not exceed 12armin (including on-ground positioning accuracy, thermoelastic behaviour...)

#



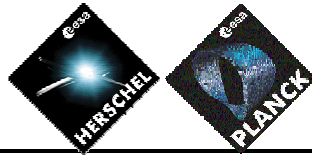

## 7.2 At-SVM level

# Reformulated Requirement covered by ACP-050-H

Between two calibrations, the in-orbit stability of the star-tracker sensor LoS with regards to the star-tracker assembly interface coordinate system shall be less than 3 arcsec (half-cone) at 68% confidence level.

#

# ALP-010-H

The in-orbit star-tracker LOS alignment bias with regards to the PLM/SVM Interface -X direction shall be lower than +/- 0.25deg half cone.

#

# Requirement

The in-orbit alignment stability of the thruster together with its on-ground push direction knowledge with regards to SVM I/F reference frame shall be less than +/-0.25°

# Requirement

The thruster plume adjustment range shall be at least +/-1.2°- for thruster plume system level alignment.

# Requirement ALD-005-H

SVM will be equipped with at least 2 optical cubes (1 nominal, 1 for redundancy). They shall represent the SVM interface frame.

#

# Requirement

SVM cubes shall allow an orientation knowledge than 10arcsec in the three directions, and shall be accessible at system level, especially before and after the mating between H-PLM and SVM.

#

## 7.3 At system level

# Requirement

The alignment accuracy of the thruster plume with regards to the S/C Coordinate system - at system level- shall be better than +/-3 arcmin

#

# Requirement

The S/C CoG on-ground knowledge accuracy shall be better than [+/-14; +/-1; +/-1]mm

#

# Requirement

The distance between the actual on-ground location of S/C CoG and its theoretical position shall be less than +/-30mm.

#

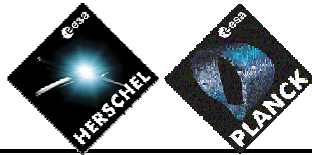

APPENDICES :

Annex 1 alignment cubes accessibility at satellite AIT level

Annex 2 MRC4 accessibility at satellite level

Annex 3 STR integration sequence

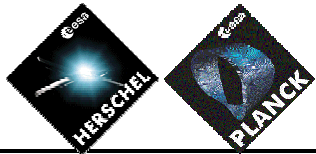

ANNEX 1 Herschel Telescope alignment cubes access

Herschel Telescope alignment cubes access [AD11]

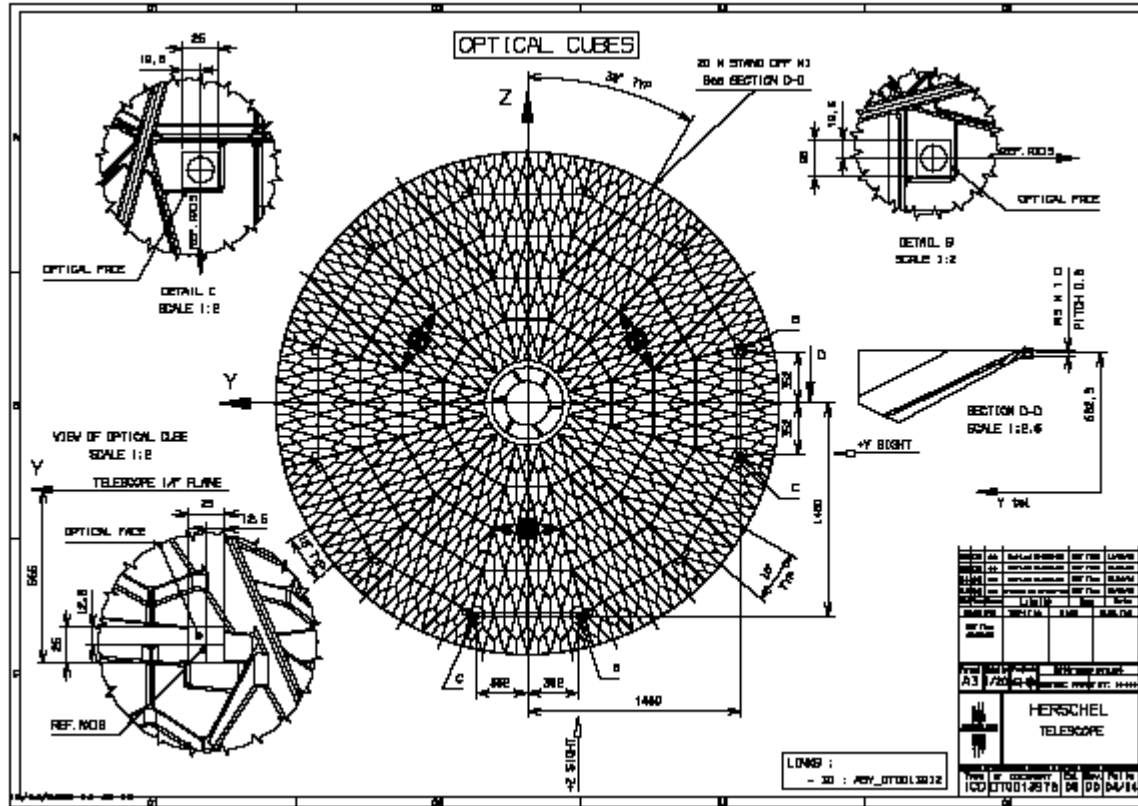

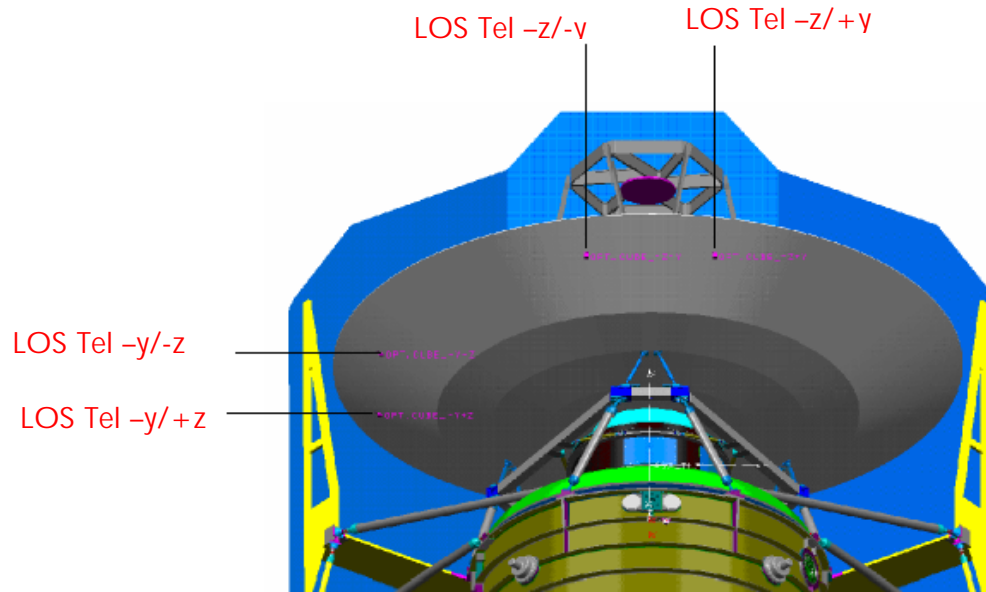
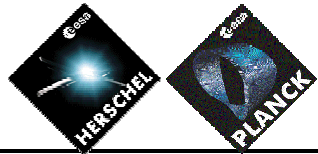

Telescope LOS description

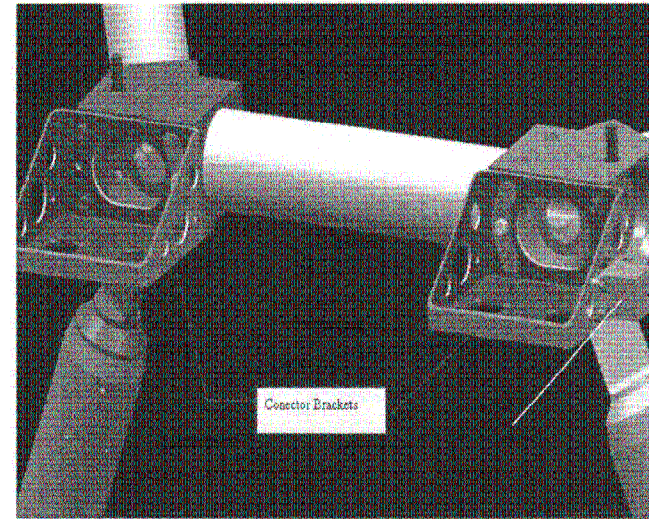

LOS TMSy

LOS TMSz

TMS LOS description

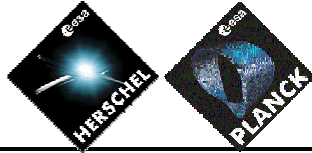

H-PLM cube access (see [AD10])

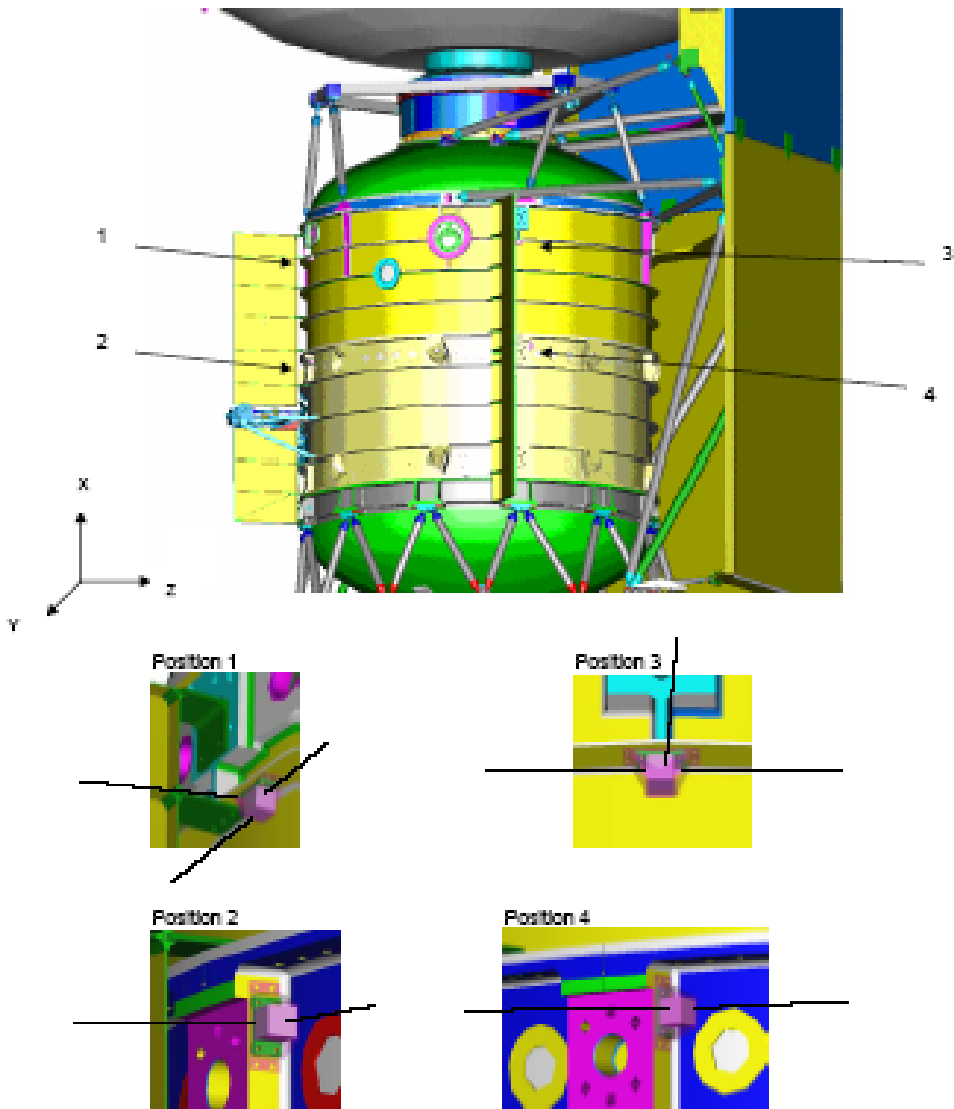

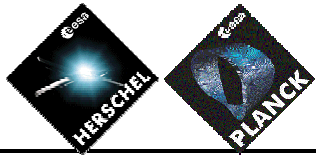

SVM cube access (see [AD12])

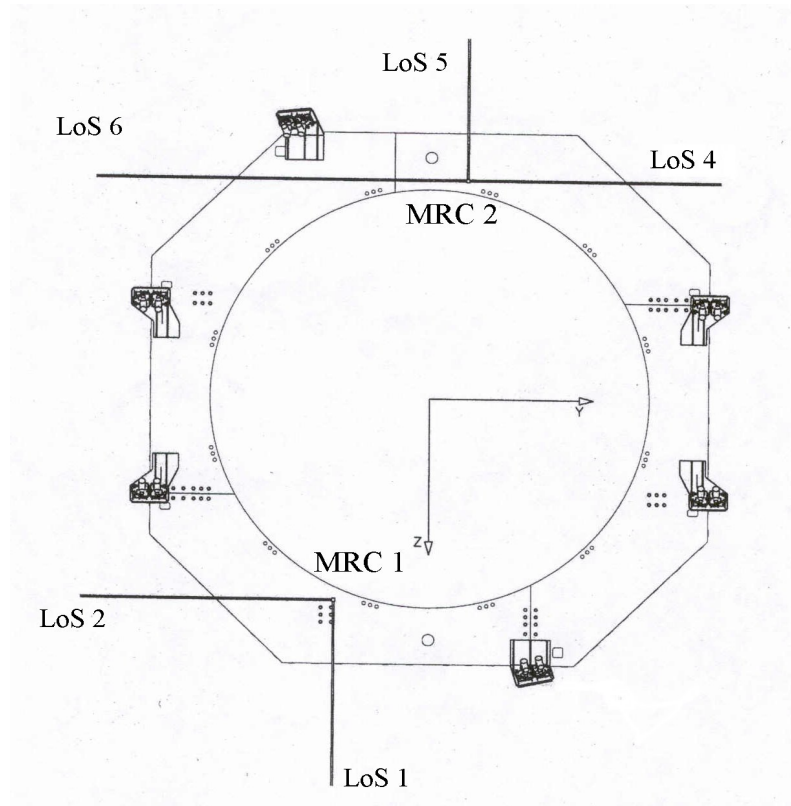

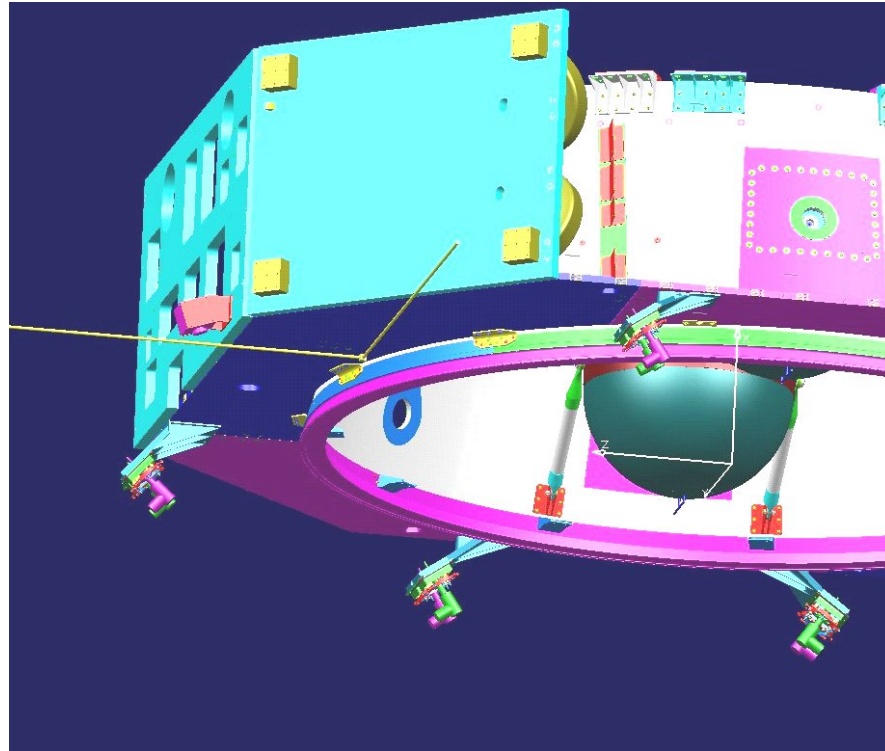
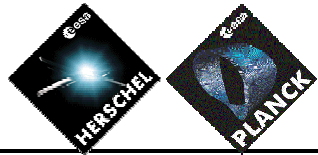

Herschel SVM MRC 1.

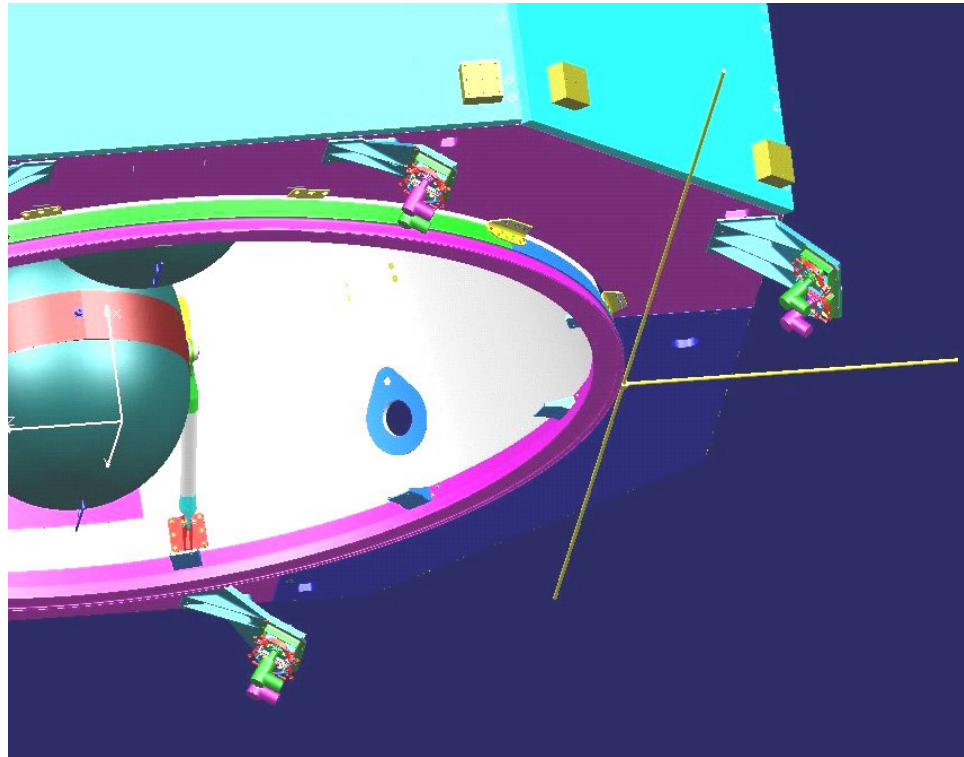
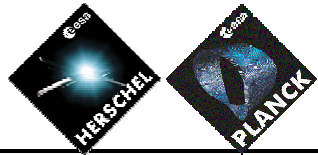

Herschel SVM MRC 2.



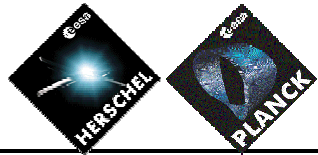

Herschel Satellite alignment cube access (see [AD5])

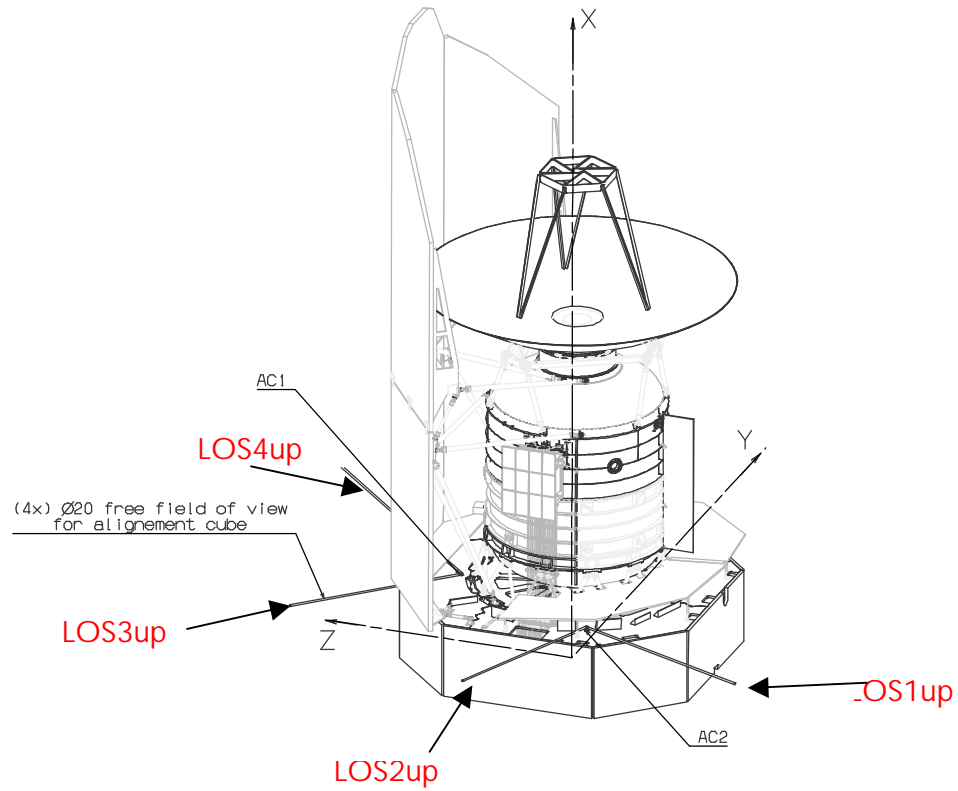

note : AC2 is also called MRC3 and AC1 is also called MRC4

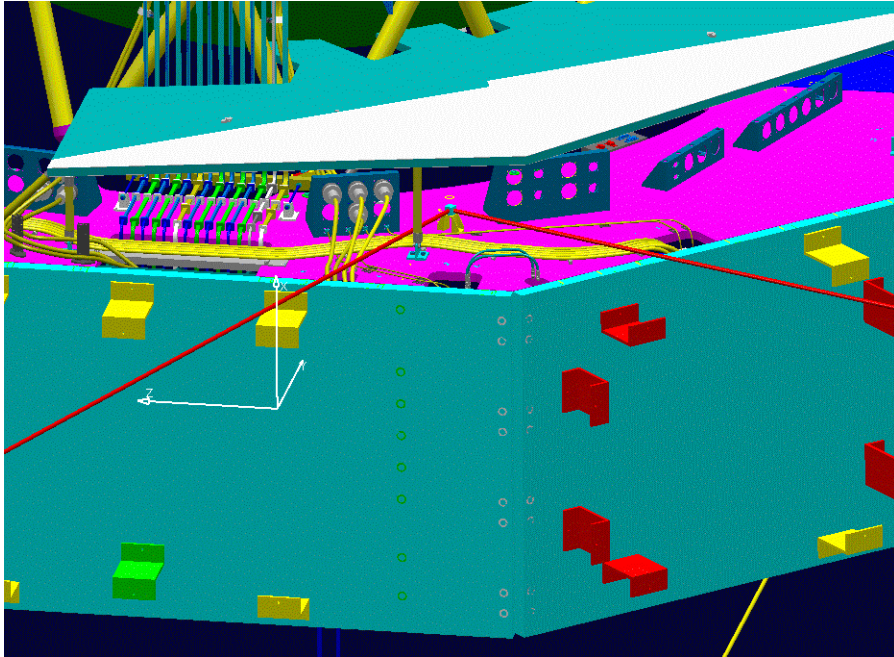
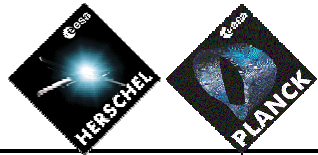

MRC3 (AC2) LOS

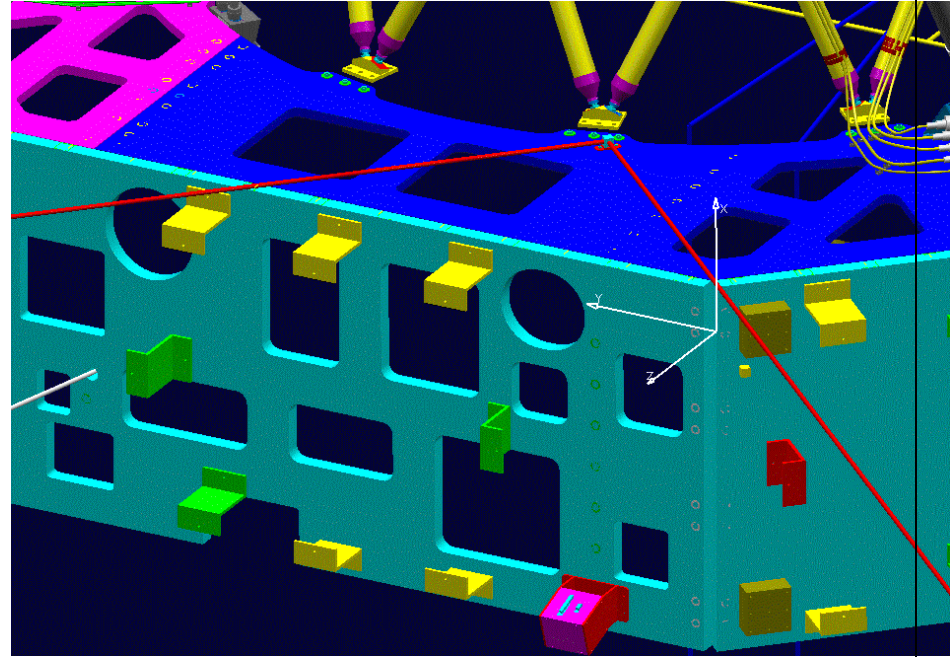

MRC4 (AC1) LOS

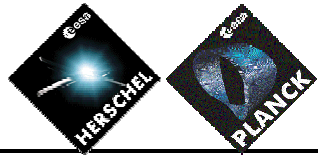

Between HSS and SVM, MRC4(AC1) cube accessibility is possible, but needs some MLI removal. More precisely, the MLI on +Z side is covers the cube (this is needed to create an venting path) So, two steps are needed to access to this cube

1. MLI skirt opening between HSS and SVM between
2. MLI blanket opening on SVM +Z side. At this stage, the visibility from +Z should be the following:

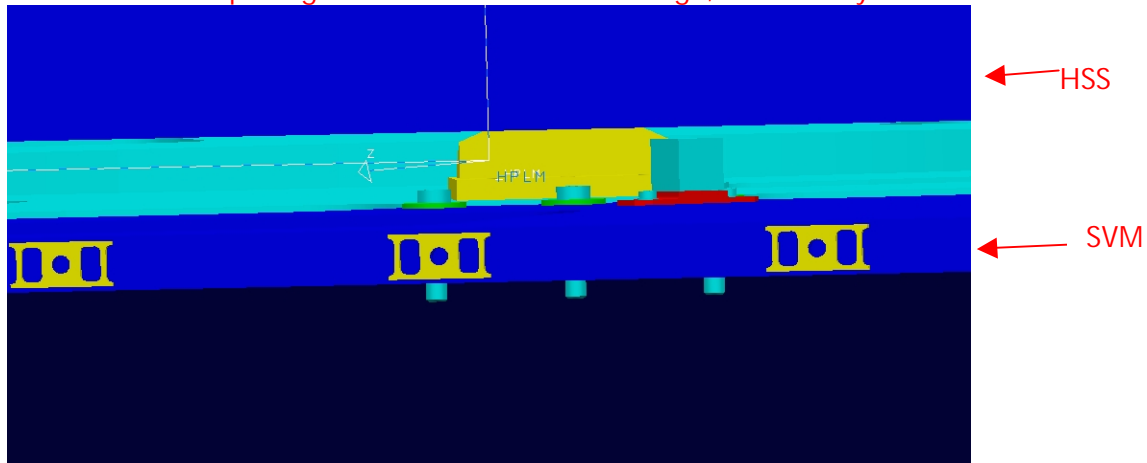

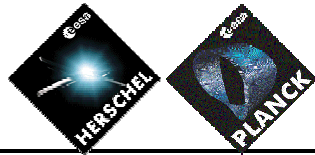

MRC3(AC2) cube access necessitates the MLI opening. The cube is elevated to be visible above the harness:

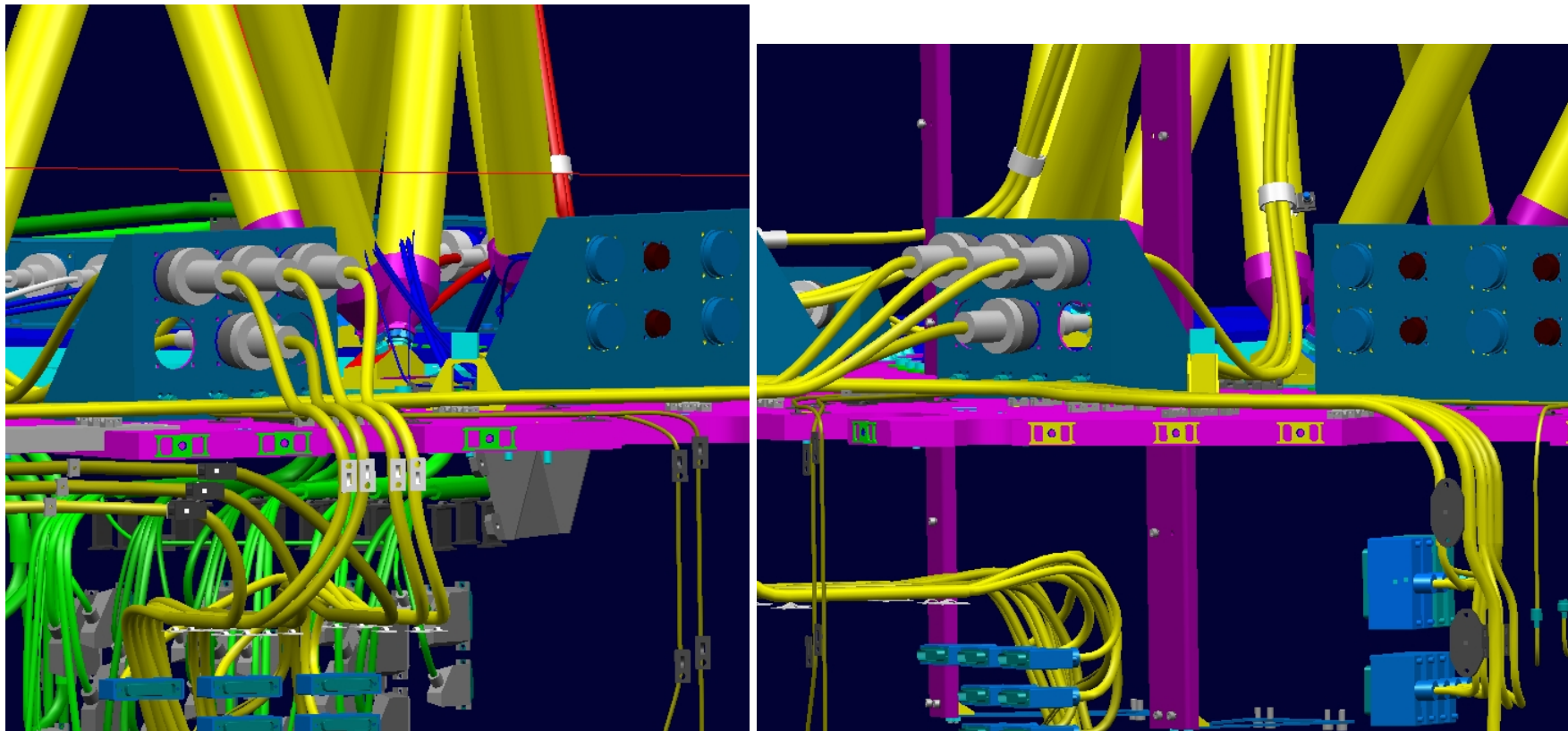

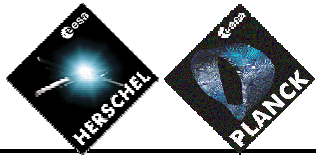

SVM equipment (see [RD6])  
Reaction wheels (on the -Y+Z SVM panel)

In order to have LoS 8 & 9 visible, two dedicated cut-outs are foreseen on -Y +Z panel and on the wheels support brackets.

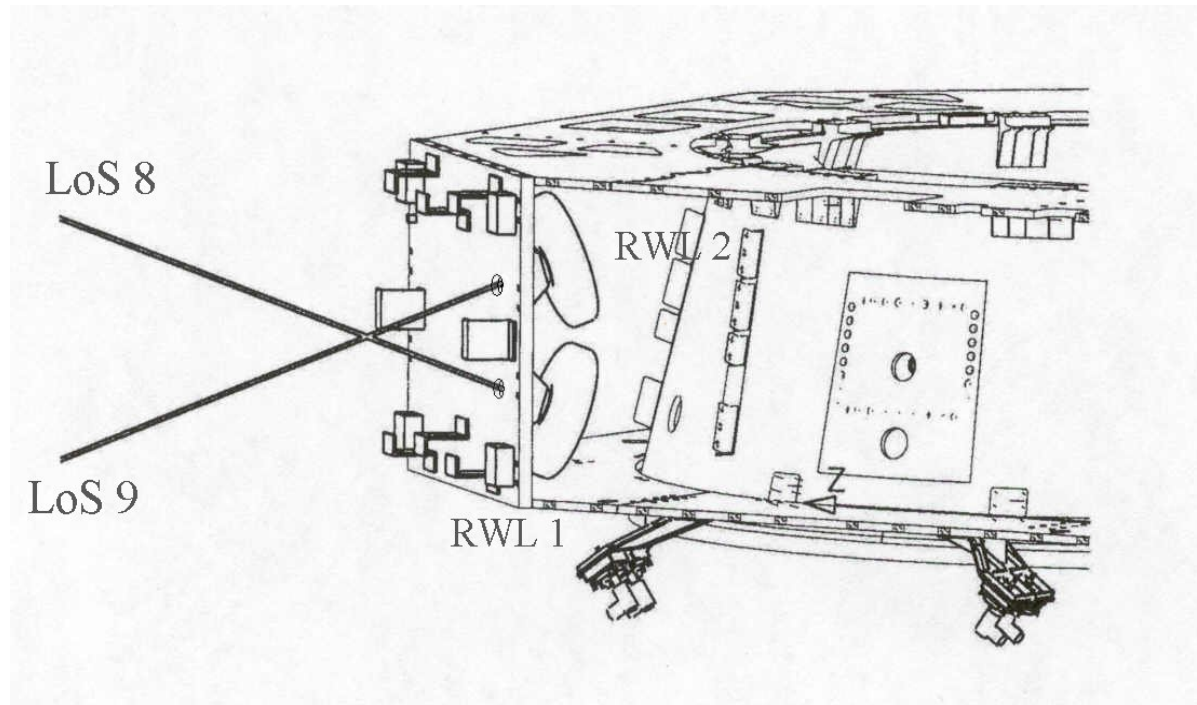



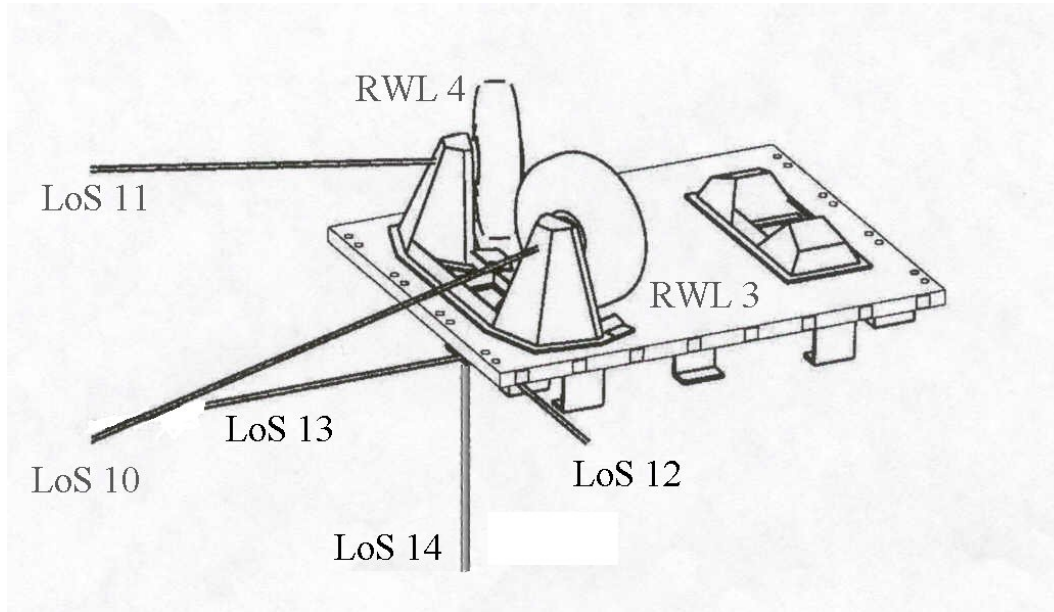
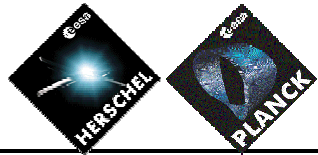

Herschel RWL 3 & 4 LoS definition. - -Y+Z panel

During satellite AIT, LOS 10 and 11 will be inside the closed SVM. Only LOS 12, 13 and 14 will be accessible.

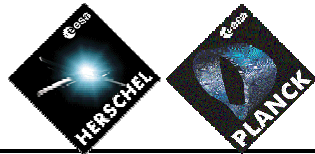

Gyro

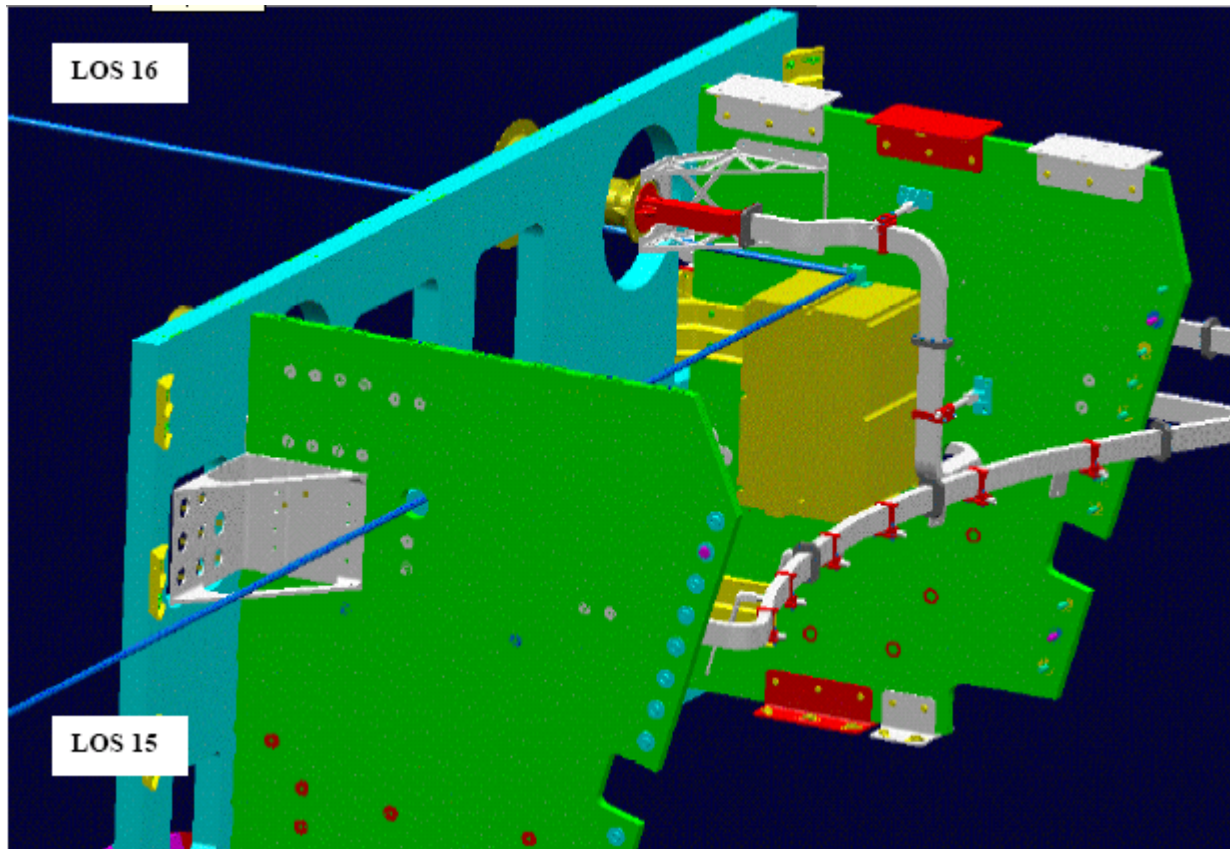

LoS 16 is accessible with all panel closed, LOS 15 is only accessible with panel-Y+Z dismounted

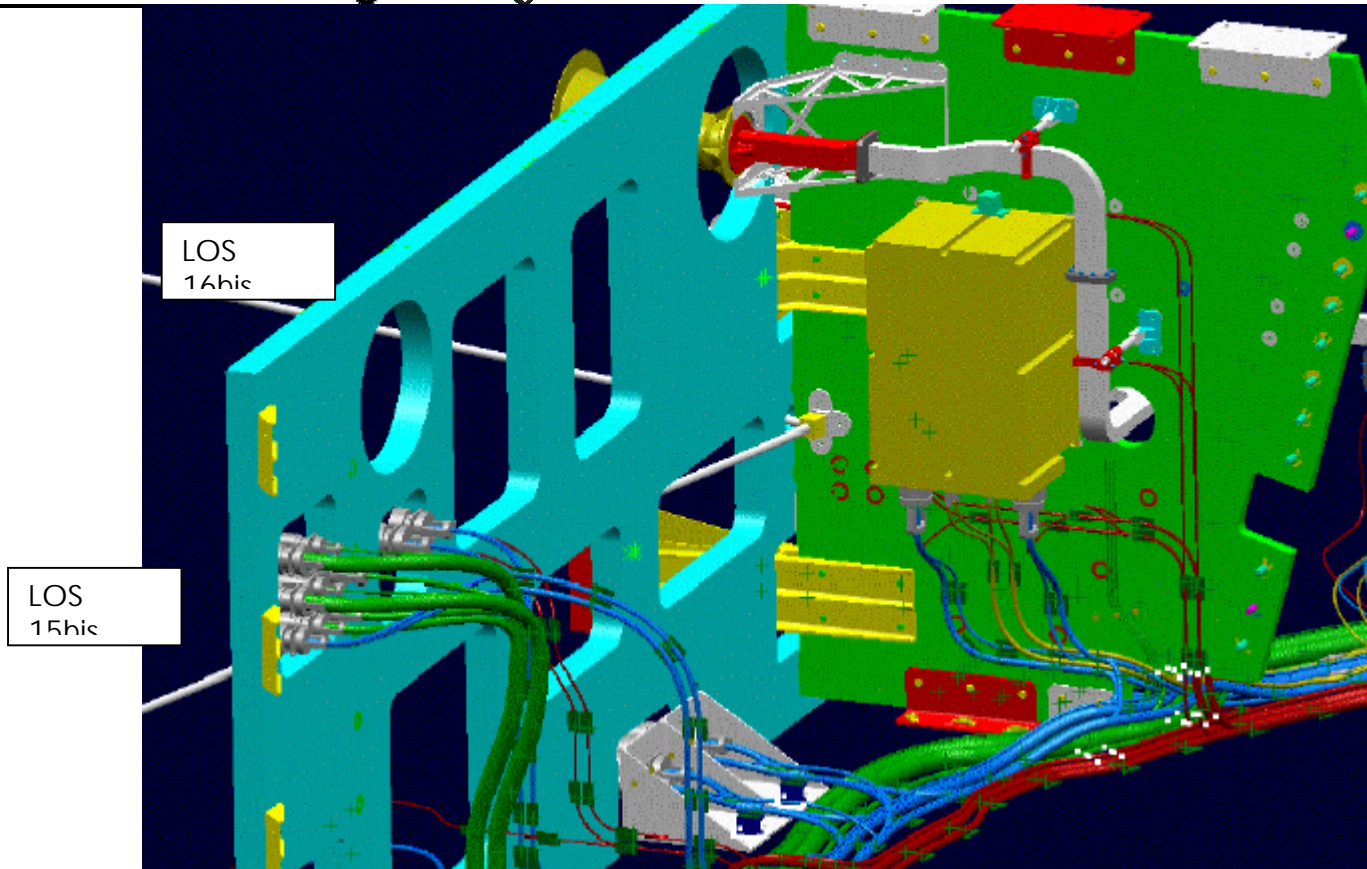
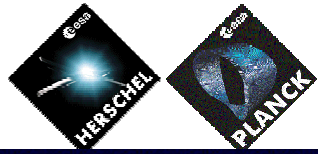

LOS 15bis and 16bis are accessible without any panel removal



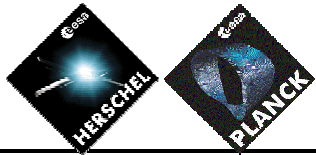

CRS ( on +Y+Z panel)

Alignment test CRS 1 & 2 Lines of Sight

Only LOS 21 and 22 of the CRS reference cube are accessible without panel removal

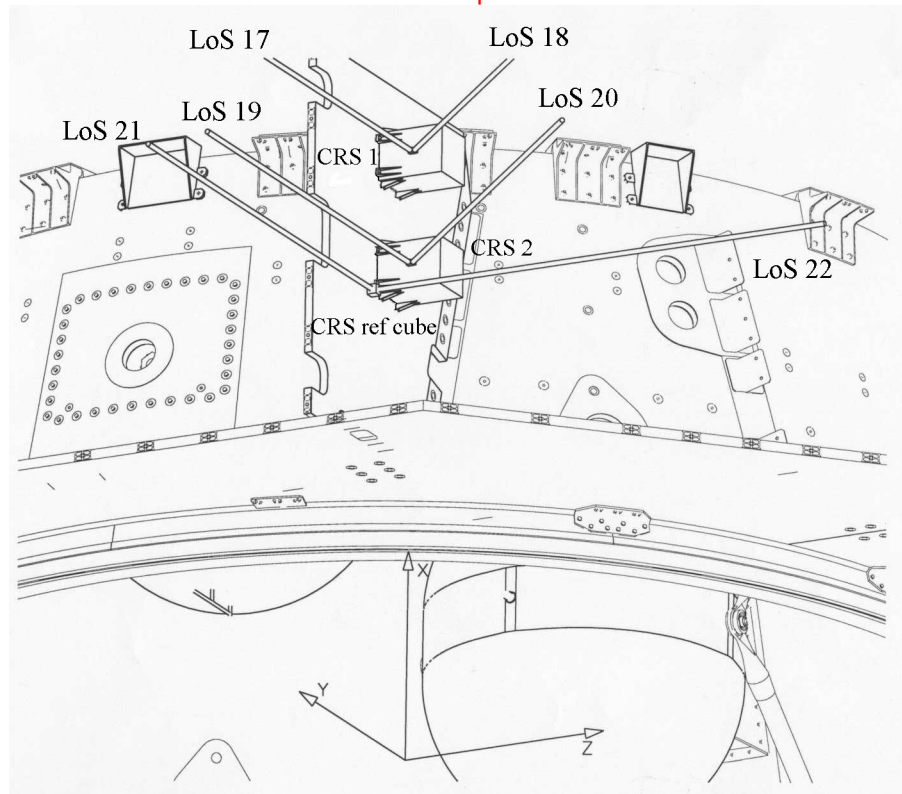

Herschel CRS 1&2 +ref cube LoS definition.

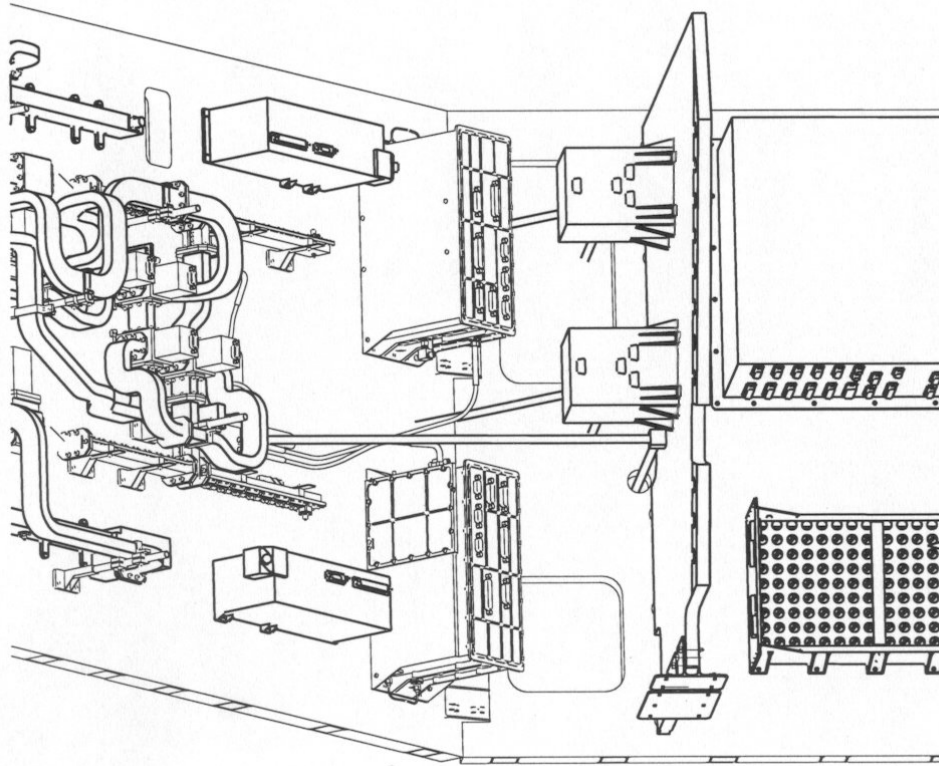
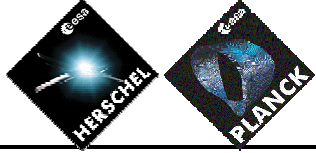

Herschel CRS 1&2 ref cube LoS.

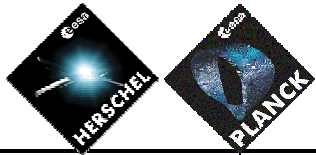

AAD  
Alignment test AAD Lines of Sight

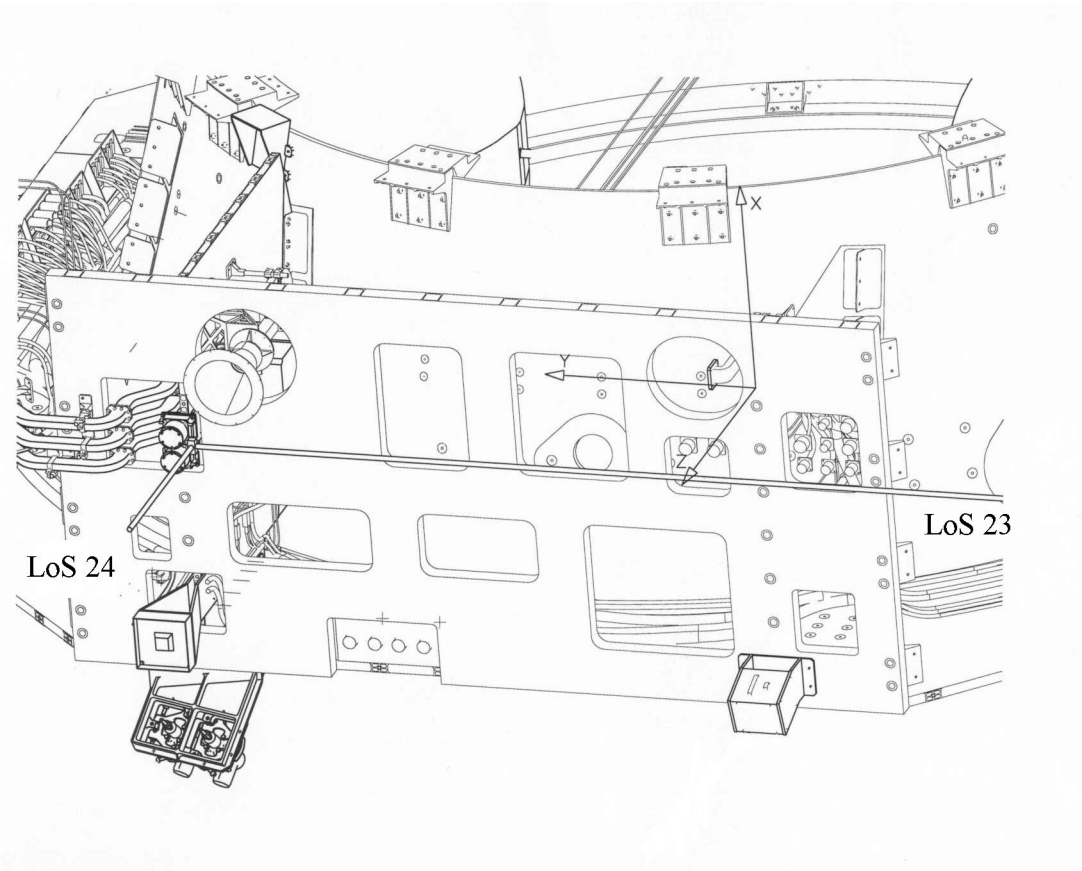

Herschel SVM AAD LoS definition.

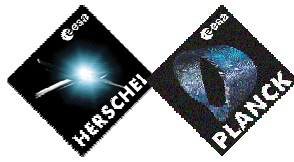

Star tracker

LOS 26 and 28 are accessible with all panel closed

LOS 25 and 27, looking toward -X, are accessible with X axis horizontal

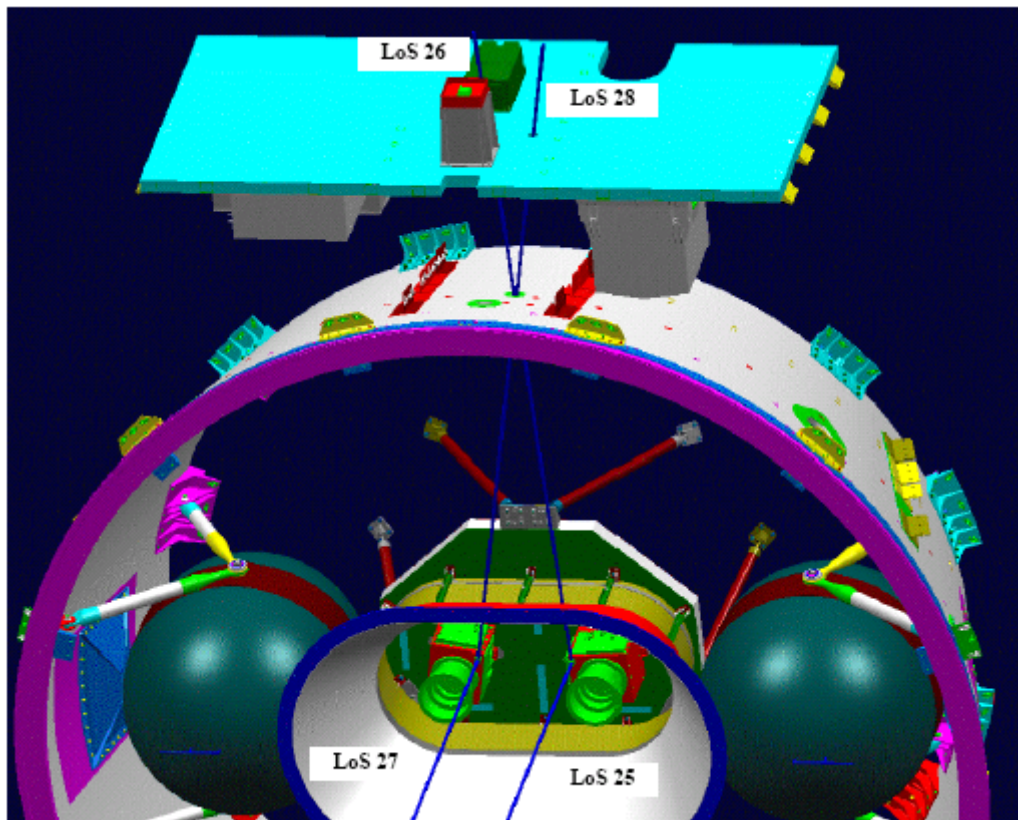
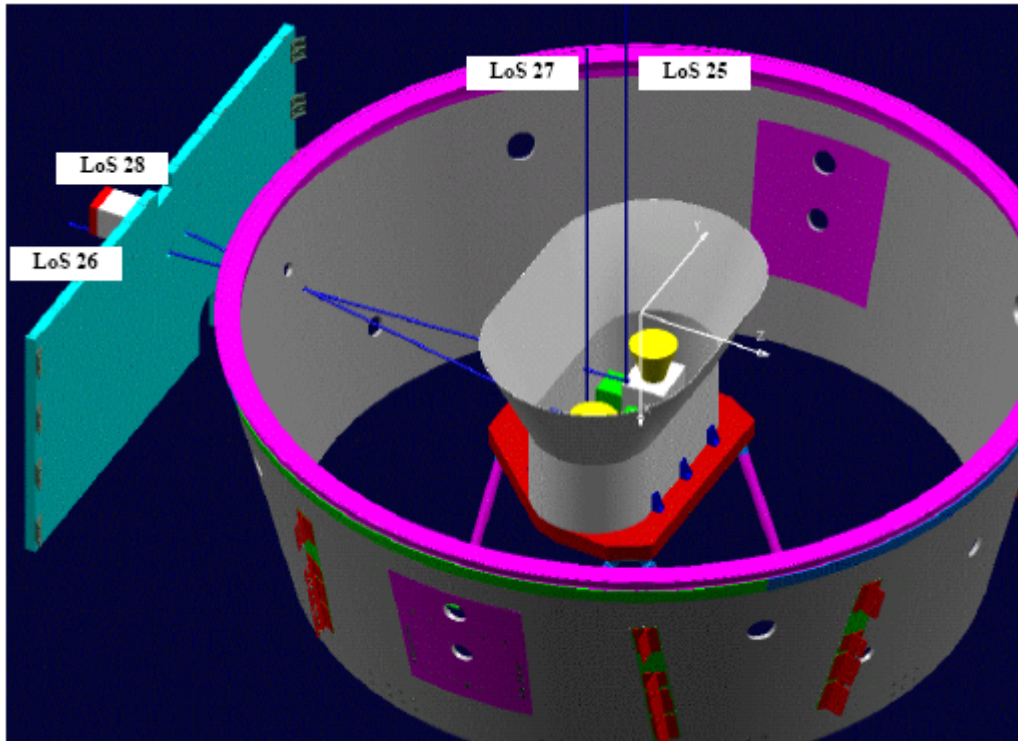





Thuster accomodation

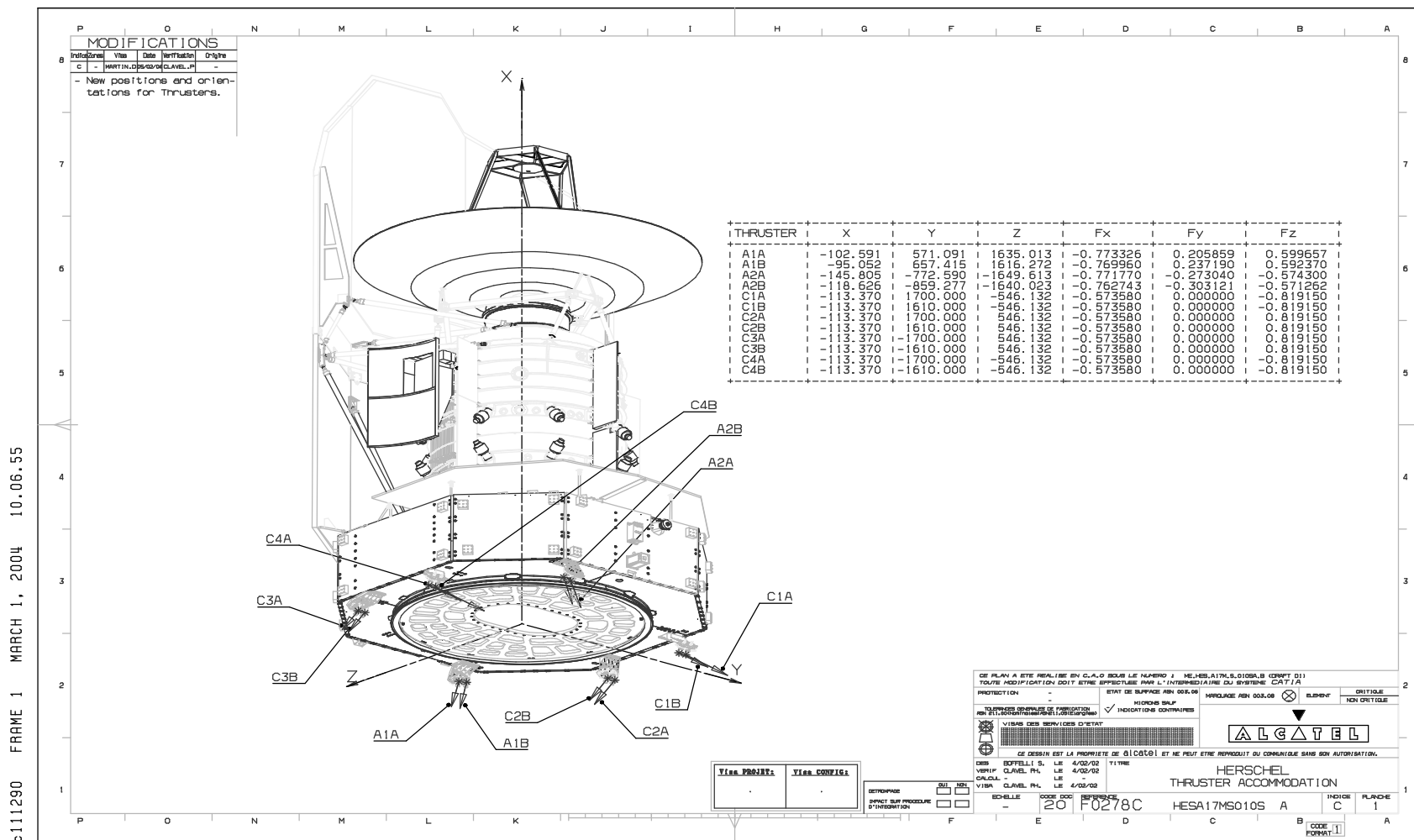





**ANNEX 2 MRC4 ACCESS PRINCIPLE AT S/C LEVEL**



Concept for the Herschel SVM Top Floor Tubes for Lines of Sight:

The Upper Closure Panel MLI features 2 u-shaped cuts at the positions, where the lines of sight protrude through the blankets.

In the final integration condition, the u-shaped cuts are closed by pieces of tape. In addition

- one u-shaped cut is covered by the PLM MLI (which is a 27 layers MLI) and
- the other u-shaped cut is covered by the PLM MLI and the SVM Barbecue MLI.

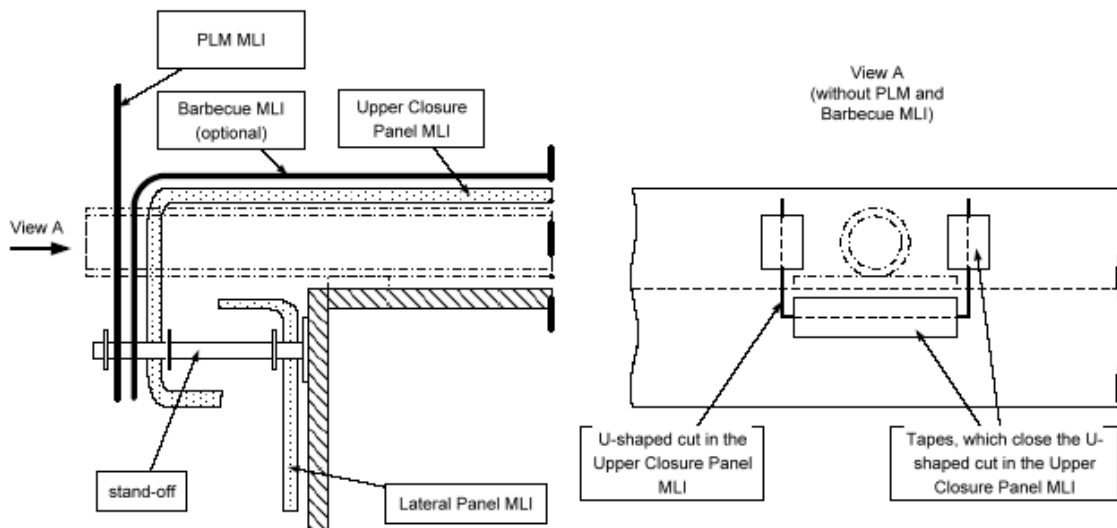
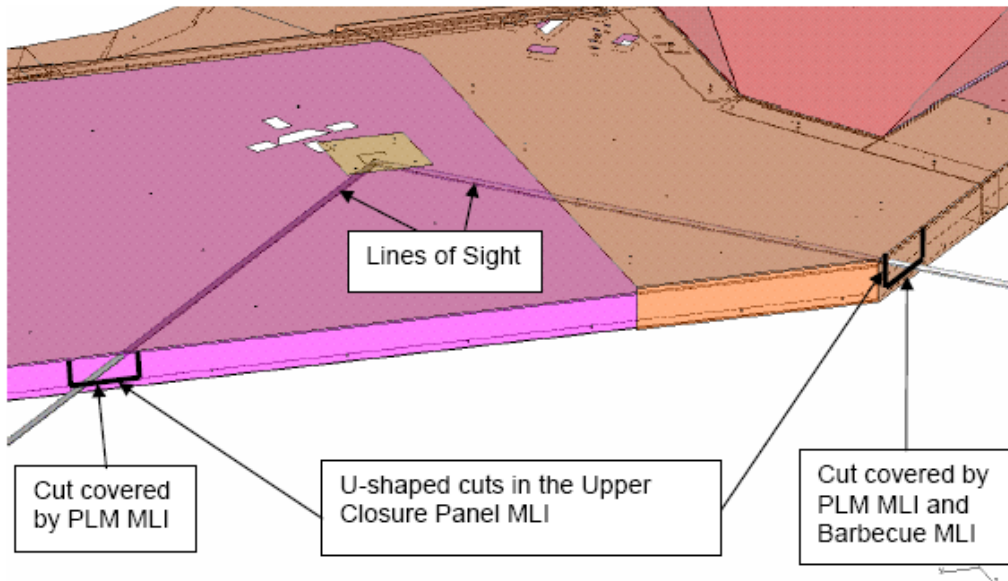





**Austrian Aerospace**

In order to be able to insert the plastic tubes for the lines of sight, the following steps have to be performed:

0. Cut the tapes open, which close the u-shaped cuts.
1. Remove the clip-washers, which are in the vicinity of the u-shaped cuts.
2. Flap the PLM MLI and the SVM Barbecue MLI (if existent) upwards.
3. Flap the u-shaped laps of the Upper Closure Panel MLI upwards.
4. Insert the tubes along the lines of sight.

Removal of the tubes is the reverse procedure.

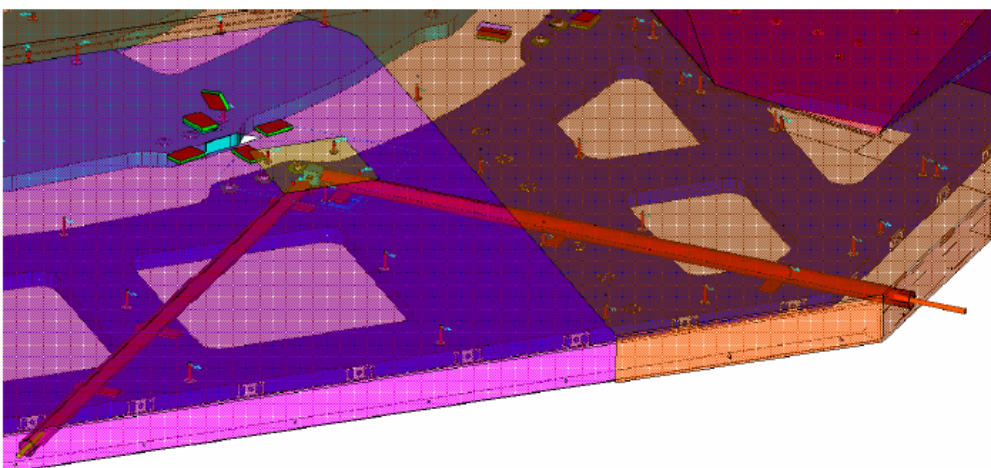
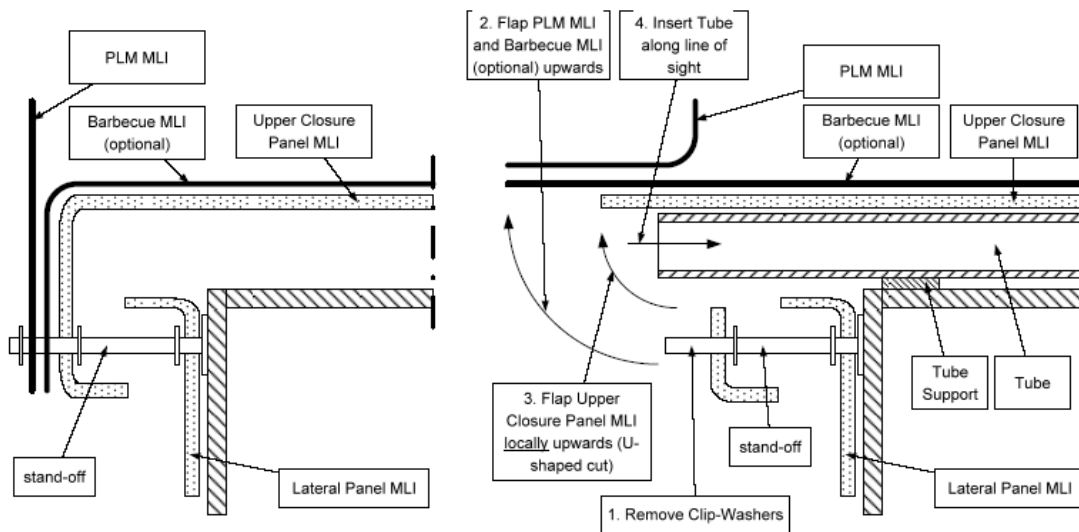

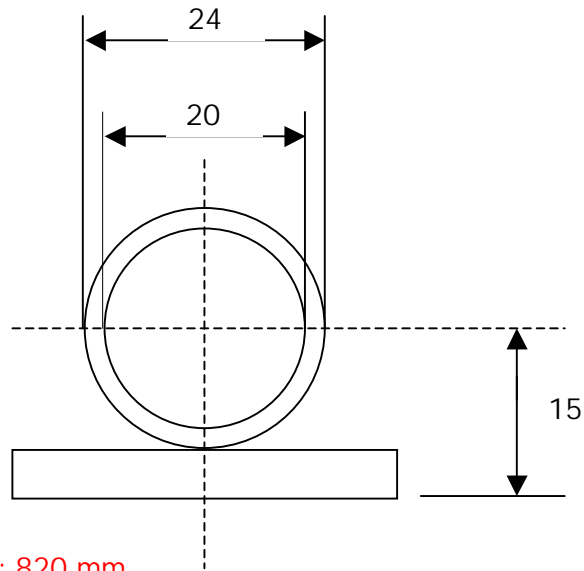

Pipe length along Line of Sight A: 820 mm

Pipe length along Line of Sight B: 850 mm

It is suggested to support each pipe by three small local baseplate (N.2 at the extremity and N.1 in the middle).

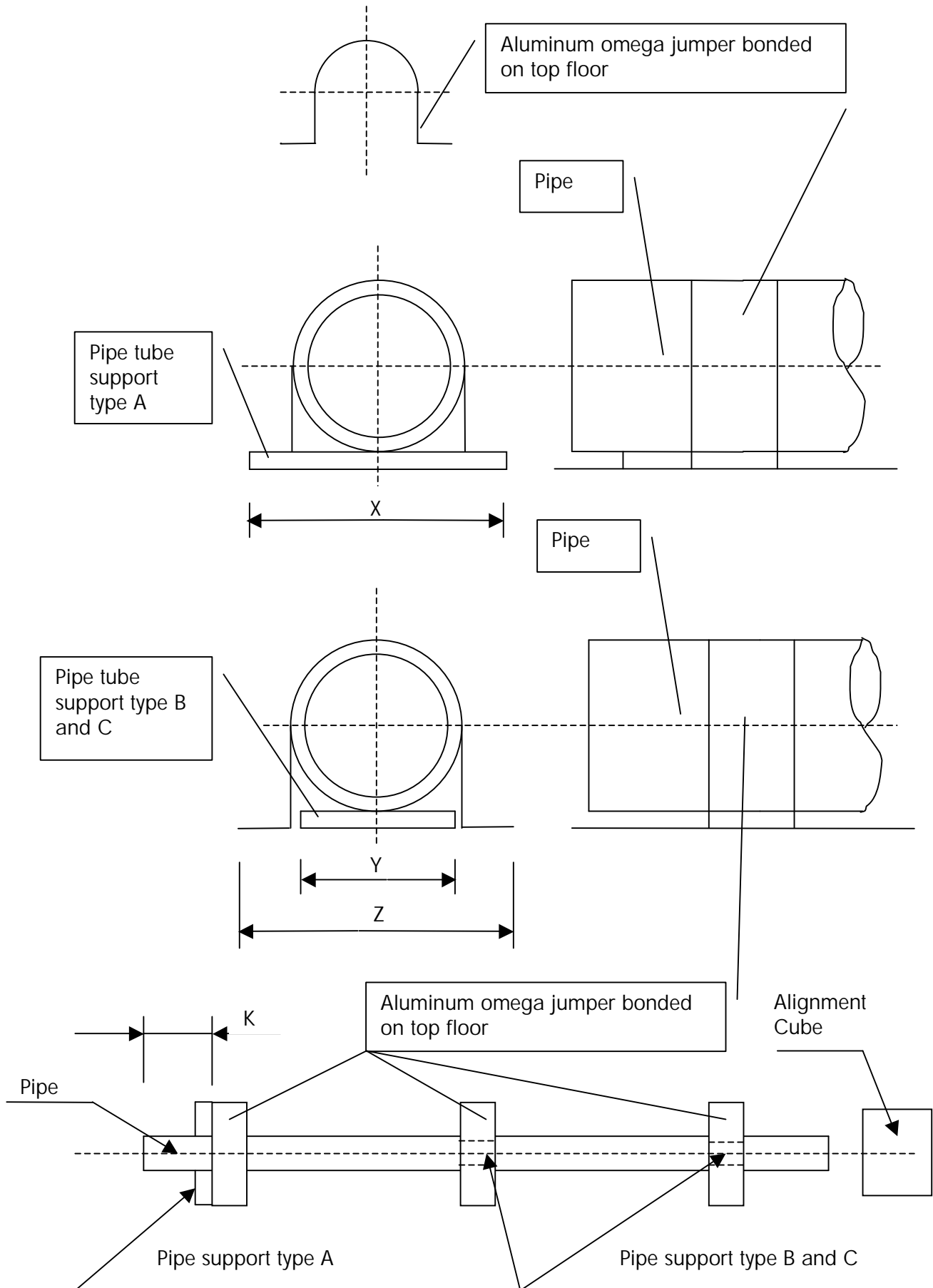
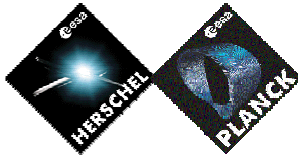

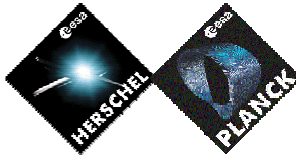

### ANNEX 3 STR integration and alignment (see also [RD6])

The star-tracker integration and alignment of Star Trackers on the H-PLM is under Alenia responsibility.

#### Alignment/integration logic

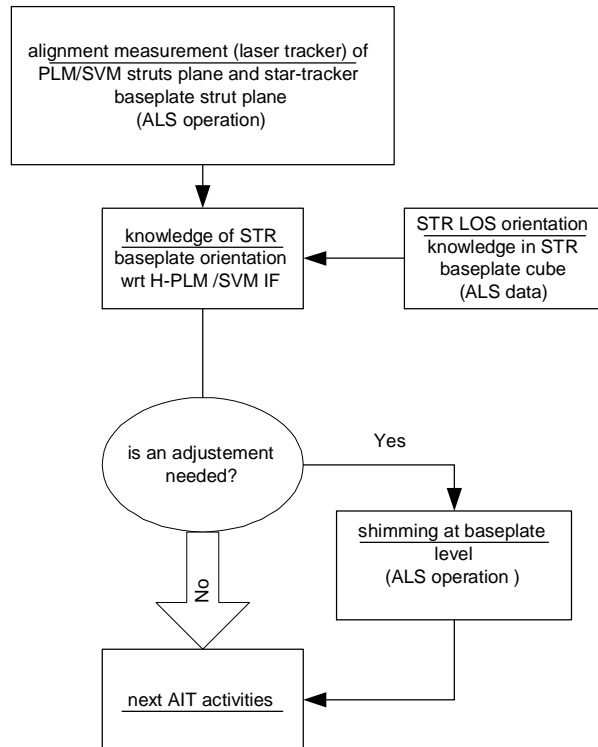

## STR Alignment/integration sequence

1. Transport by Alenia of struts, baseplate and STR as loose parts to Astrium premises
2. Installation of STR struts on the CVV
3. Measurement of 2 planes with a laser tracker (TBD by ALS)

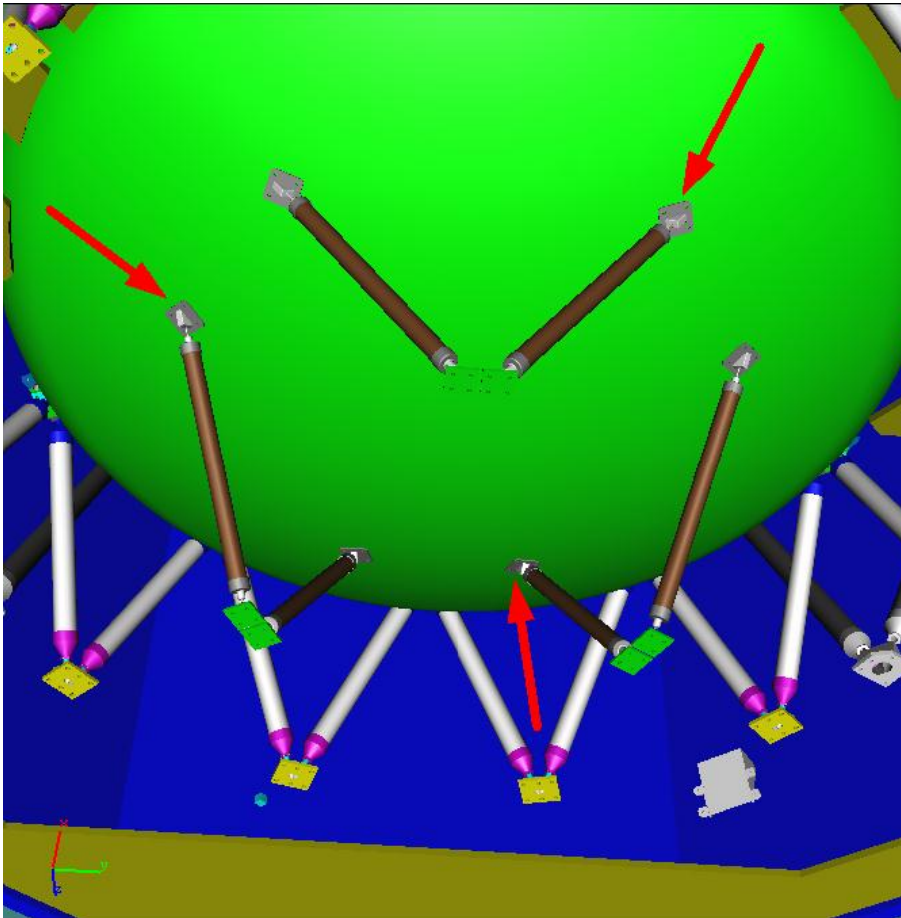

4. STR platform shims determination and manufacturing  
The STR alignment is done to fulfill the 3 constraint:
  - STR struts feet planarity to ensure a 0 stress mouting
  - STR platform X location to ensure STR cube visibility through the small holes in the SVM
  - STR platform parallelism with regards to PLM/SVM IF/plane

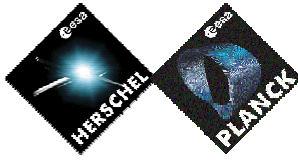

5. modules mating

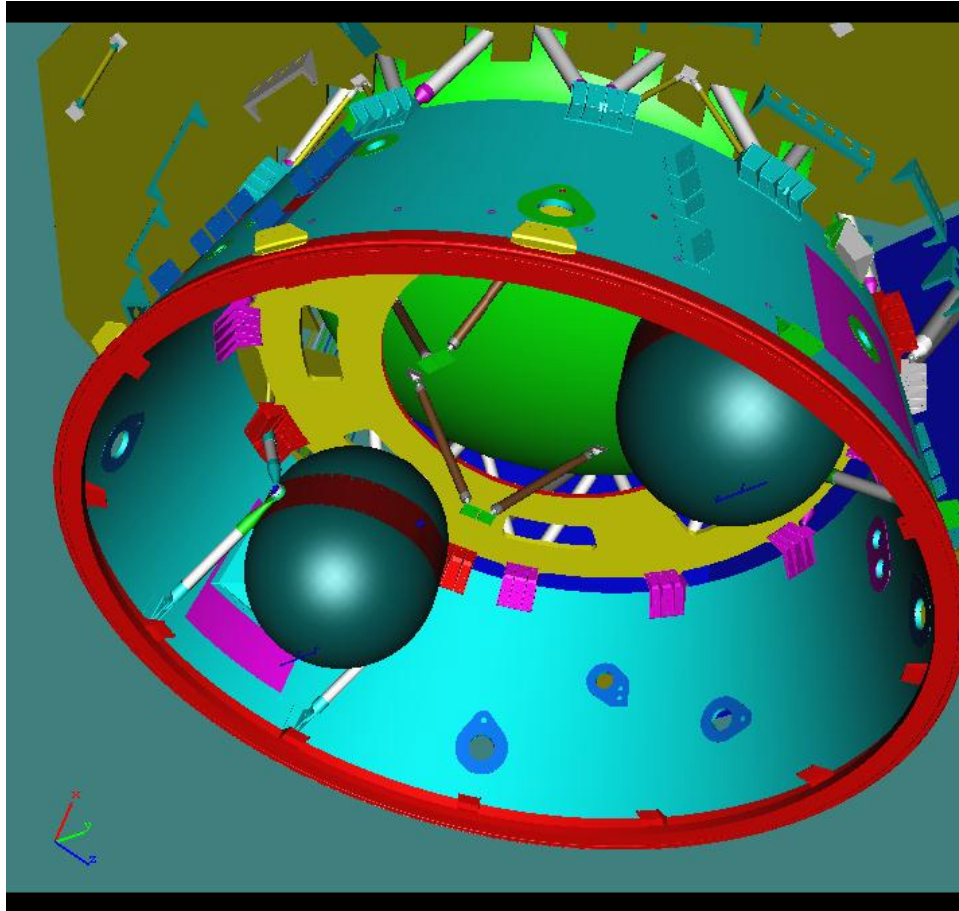

- 6. STR shims integration
- 7. Definitive STR platform integration

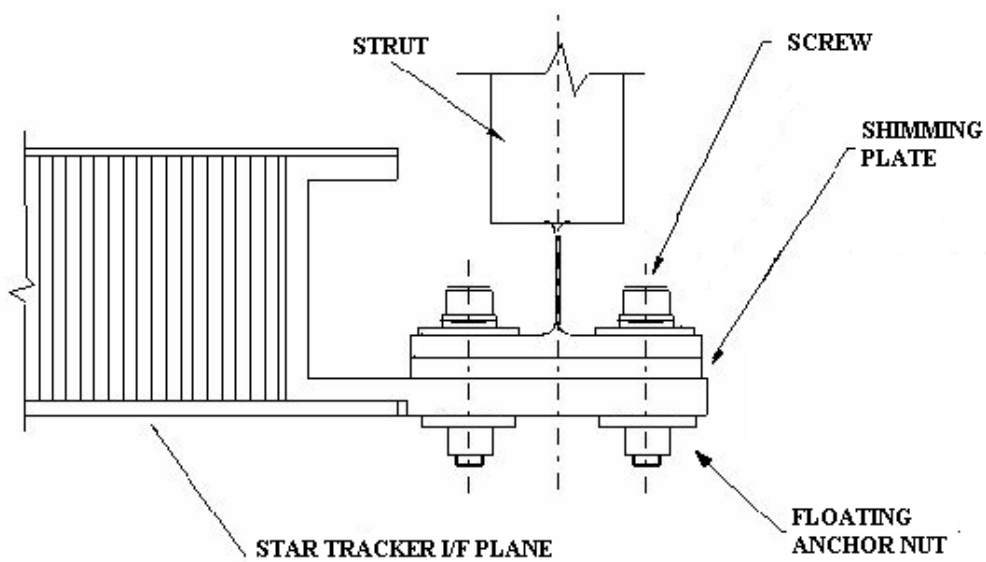



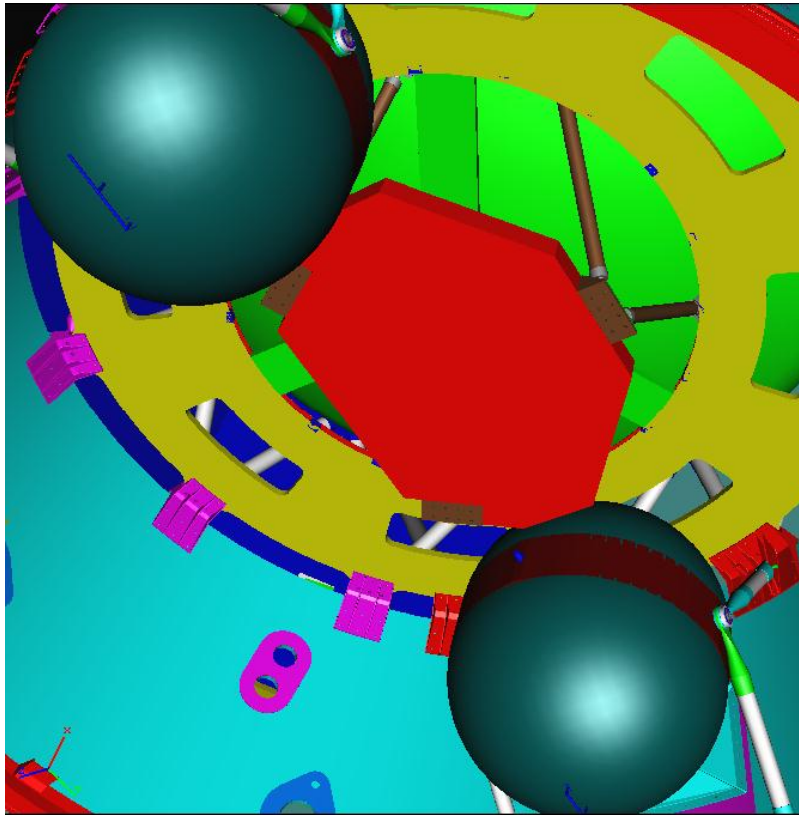

- 8. Sunshade integration
- 9. STR integration
- 10. SVM lower thermal closure integration

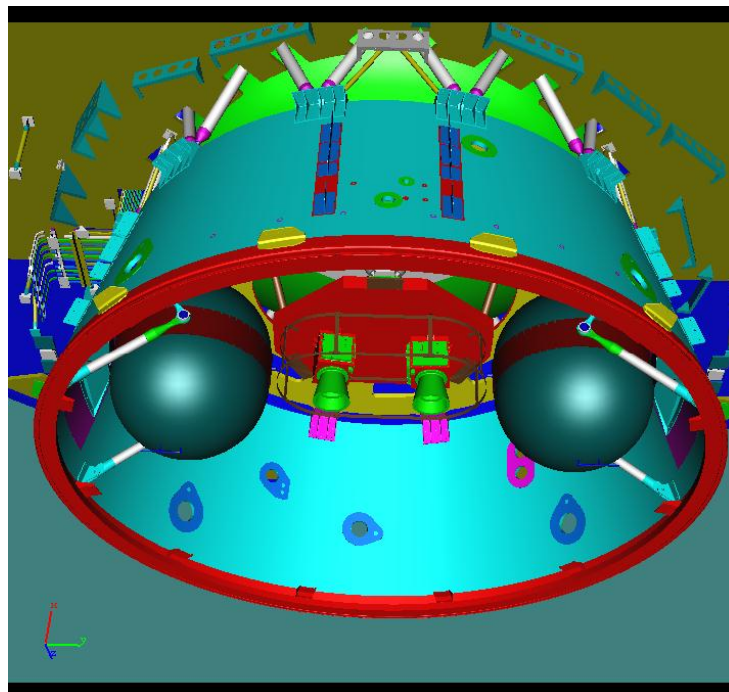

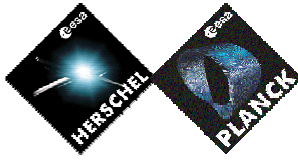

11. STR secondary baffle integration

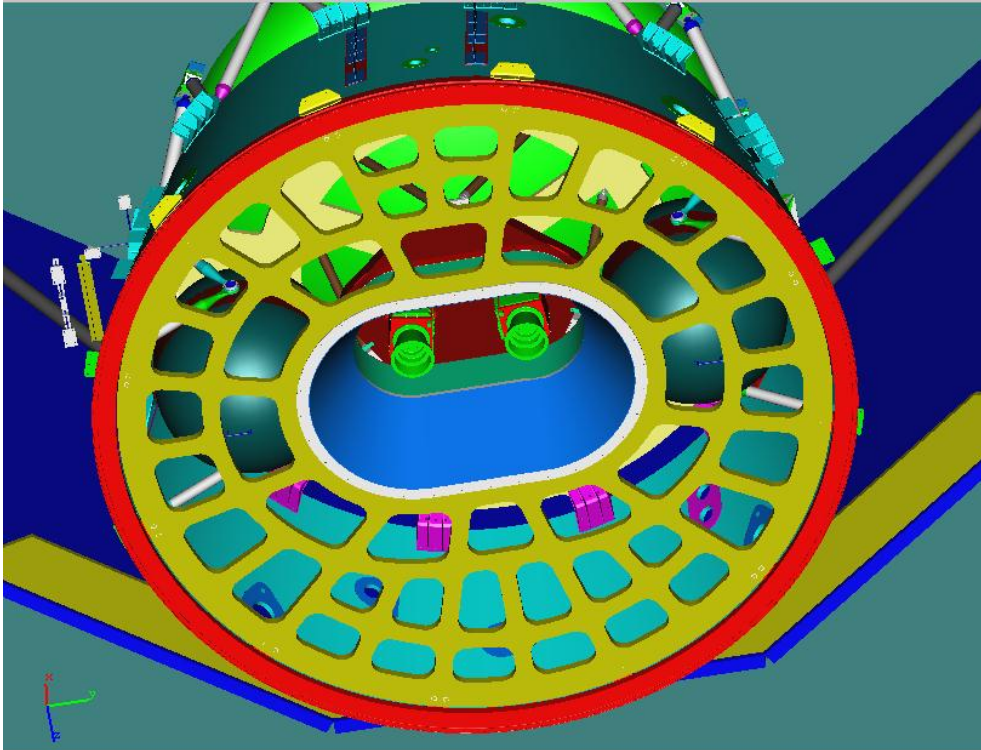



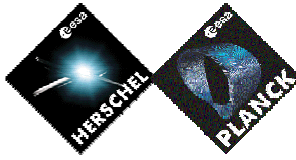

page intentionally left blank

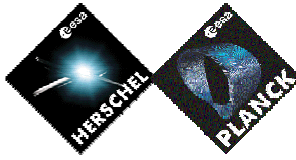

END OF DOCUMENT

page intentionally left blank