

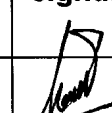



## Herschel FM Spacecraft EMC Test Requirement Specification

### H-P-2-ASP-TS-0819

### Product Code : 000 000

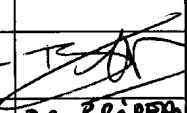
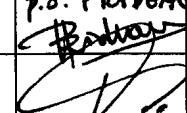
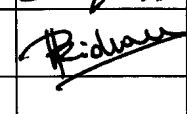
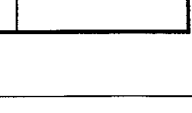
Rédigé par/ <i>Written by</i>	Responsabilité-Service-Société <i>Responsibility-Office -Company</i>	Date	Signature
M. Burlas	EMC Engineer	10/08/07	
Y. Pocchiola	RF Manager	16/08/07	
<b>Vérfié par/<i>Verified by</i></b>			
K-R. Hibberd	Electrical Interfaces Manager		
P. Couzin	Electrical Architecture Manager		
<b>Approbation/<i>Approved</i></b>			
Y. Roche	System Engineering Manager	10/8/07	
D. Montet	Herschel Satellite Manager	16/08/07	
T. Grassin	PA Manager P.O. F. GIVERINEAU	16/08/07	
J.J. Juillet	Programme Manager P.O. PRIDEAU	16/08/07	
T. Passvogel	ESA Programme Manager		

Data management : Christiane GIACOMETTI

Entité Emettrice : Thalès Alenia Space - Cannes  
(détentrice de l'original) :

# HERSCHEL FM SPACECRAFT EMC TEST REQUIREMENT SPECIFICATION

REFERENCE : H-P-2-ASP-TS-0819

DATE : 10/08/2007

ISSUE : 3

PAGE : 2/80

## DISTRIBUTION / DISTRIBUTION RECORD

HERSCHEL/PLANCK		DISTRIBUTION RECORD	
DOCUMENT NUMBER : H-P-2-ASP-TS-0819		Issue 3 / Rev. : 0 Date: 10/08/2007	
EXTERNAL DISTRIBUTION		INTERNAL DISTRIBUTION	
ESA	X	HP team	X
ASTRIUM	X		
ALENIA	X		
ARIANE SPACE	X		
		Clf Documentation	Orig.

## ENREGISTREMENT DES EVOLUTIONS / CHANGE RECORD

ISSUE	DATE	§ : DESCRIPTION DES EVOLUTIONS § : CHANGE RECORD	REDACTEUR AUTHOR
Draft 1	20/07/2004 01/02/2007	Draft issue First issue ( : excepted § relevant to RF autocompatibility written by Y. Pocchiola)	J. Gallagher M. Burlas* Y. Pocchiola
2	29/06/2007	Second issue following RID n°42 FM-07 agreements and dispositions taken during EMC splinter meeting dated 29-05-07 ( : excepted § relevant to RF autocompatibility written by Y. Pocchiola)	M. Burlas* Y. Pocchiola
3	10/08/2007	Third issue including additional CE tests on DECMEC and BOLC	M. Burlas

## TABLE OF CONTENTS

DISTRIBUTION / DISTRIBUTION RECORD .....	2
ENREGISTREMENT DES EVOLUTIONS / CHANGE RECORD .....	3
TABLE OF CONTENTS .....	4
1. SCOPE.....	7
2. DOCUMENTS .....	7
2.1 APPLICABLE DOCUMENTS .....	7
2.2 REFERENCE DOCUMENTS .....	7
3. SYSTEM LEVEL FUNCTIONAL AND PERFORMANCE SUCCESS CRITERIA .....	7
4. TEST ORGANIZATION AND RESPONSIBILITIES.....	9
4.1 ORGANIZATION .....	9
4.2 RESPONSIBILITIES.....	9
4.3 TASKS BREAKDOWN AND DISTRIBUTION .....	11
5. SPACECRAFT CONFIGURATION DURING TESTS .....	13
6. SPACECRAFT LEVEL EMC TESTS .....	16
7. TEST REQUIREMENT SHEETS.....	18
7.1 CE CURRENT ON PRIMARY POWER LINES TOWARDS PCDU .....	18
7.1.1 Test objectives .....	18
7.1.2 Type of test.....	18
7.1.3 Summary test definition.....	18
7.1.4 Test acceptance criteria.....	20
7.1.5 Responsibilities (see §7 of RD01) .....	20
7.2 CE VOLTAGE ON PRIMARY POWER LINES TOWARDS PCDU .....	21
7.2.1 Test objectives .....	21
7.2.2 Type of test.....	21
7.2.3 Summary test definition.....	21
7.2.4 Test set-up and test support.....	22
7.2.5 Test acceptance criteria.....	22
7.2.6 Responsibilities (see §7 of RD01) .....	23
7.3 CE CURRENT ON SIGNAL LINES.....	24
7.3.1 Test objectives .....	24
7.3.2 Type of test.....	24
7.3.3 Summary test definition.....	24
7.3.4 Test acceptance criteria.....	25
7.3.5 Responsibilities (see §7 of RD01) .....	25
7.4 CE VOLTAGE RIPPLE ON SIGNAL LINES.....	26

# HERSCHEL FM SPACECRAFT EMC TEST REQUIREMENT SPECIFICATION

REFERENCE : H-P-2-ASP-TS-0819

DATE : 10/08/2007

ISSUE : 3

PAGE : 5/80

7.4.1	Test objectives .....	26
7.4.2	Type of test.....	26
7.4.3	Summary test definition.....	26
7.4.4	Test acceptance criteria.....	27
7.4.5	Responsibilities (see §7 of RD01).....	27
7.5	<b>CS VOLTAGE ON SIGNAL LINES (TO BE PERFORMED IN CASE OF NC WITH CE TESTS)</b> .....	28
7.5.1	Test objectives .....	28
7.5.2	Type of test.....	28
7.5.3	Summary test definition.....	28
7.5.4	Test acceptance criteria.....	30
7.5.5	Responsibilities (see §7 of RD01).....	30
7.6	<b>RE E-FIELD NARROWBAND AT VEB PLANE IN LAUNCH MODE (TBC)</b> .....	31
7.6.1	Test objectives .....	31
7.6.2	Type of test.....	31
7.6.3	Summary test definition.....	31
7.6.4	Test set-up and test support.....	34
7.6.5	Test acceptance criteria.....	34
7.6.6	Responsibilities (see §7 of RD01).....	34
7.7	<b>RE E-FIELD NARROWBAND AT UHF AND C-BAND IN LAUNCH MODE (TBC)</b> .....	35
7.7.1	Test objectives .....	35
7.7.2	Type of test.....	35
7.7.3	Summary test definition.....	35
7.7.4	Test set-up and test support.....	37
7.7.5	Test acceptance criteria.....	37
7.7.6	Responsibilities (see §7 of RD01).....	38
7.8	<b>RE E-FIELD NARROWBAND IN OPERATIONAL MODE</b> .....	39
7.8.1	Test objectives .....	39
7.8.2	Type of test.....	39
7.8.3	Summary test definition.....	39
7.8.4	Test set-up and test support.....	43
7.8.5	Test acceptance criteria.....	44
7.8.6	Responsibilities (see §7 of RD01).....	44
7.9	<b>SPACECRAFT RADIATED SUSCEPTIBILITY TO LAUNCHER &amp; LAUNCH SITE EMISSIONS</b> .....	45
7.9.1	Test objectives .....	45
7.9.2	Type of test.....	46
7.9.3	Summary test definition.....	46
7.9.4	Test set-up and test support.....	47
7.9.5	Test acceptance criteria.....	48
7.9.6	Responsibilities (see §7 of RD01).....	48
7.10	<b>SPACECRAFT PLM RADIATED SUSCEPTIBILITY E-FIELD</b> .....	49
7.10.1	Test objectives.....	49
7.10.2	Type of test .....	49
7.10.3	Summary test definition .....	49
7.10.4	Test set-up and test support .....	52
7.10.5	Test acceptance criteria .....	53

# HERSCHEL FM SPACECRAFT EMC TEST REQUIREMENT SPECIFICATION

REFERENCE : H-P-2-ASP-TS-0819

DATE : 10/08/2007

ISSUE : 3

PAGE : 6/80

---

7.10.6	Responsibilities (see §7 of RD01) .....	53
7.11	SPACECRAFT PLM RADIATED SUSCEPTIBILITY TRANSIENT MAGNETIC FIELD .....	54
7.11.1	Test objectives.....	54
7.11.2	Type of test .....	54
7.11.3	Summary test definition .....	54
7.11.4	Test set-up and test support .....	56
7.11.5	Test acceptance criteria.....	56
7.11.6	Responsibilities (see §7 of RD01) .....	57
7.12	SPACECRAFT RF AUTO-COMPATIBILITY .....	58
7.12.1	Test objectives.....	58
7.12.2	Summary test definition .....	58
7.12.3	Test set-up and test support .....	67
7.12.4	Test acceptance criteria.....	67
7.12.5	Responsibilities (see §7 of RD01) .....	67
8.	ABBREVIATIONS.....	69
ANNEX 1 : TEST AID DEFINITION .....		72
ANNEX 2 : RWLS CS TESTS CONFIGURATIONS.....		78
ANNEX 3 : RWLS IDS FOR TOCO AND TD MEASUREMENTS.....		79

## 1. SCOPE

The purpose of this Test Requirement Specification (TRS) is to define the tests to be performed after Spacecraft integration in order to verify Electromagnetic Compatibility of the satellite with itself and with the specific launch vehicle (ARIANE 5) and associated launch facility transmitters/receivers.

It is also used to confirm the system level compatibility margins, this testing defined in this document may be revised following the results of Instrument/unit level EMC testing.

For the purpose of this TRS it has been assumed that all bonding/isolation testing has been successfully carried out at equipment, Instrument, Module and Spacecraft levels.

Attention shall be paid to the fact that radiated emissions tests at VEB plane w.r.t. the launch vehicle are TBC in the frame of discussions with ARIANE SPACE.

## 2. DOCUMENTS

### 2.1 APPLICABLE DOCUMENTS

- [AD01] Herschel/Planck EMC Specification, H-P-1-ASPI-SP-0037, issue 4
- [AD02] Herschel EMC Test Plan, HP-2-ASED-PL-0037, issue 1
- [AD03] Herschel grounding diagram, H-P-2-ASPI-TN-0199, issue 1

### 2.2 REFERENCE DOCUMENTS

- [RD01] HERSCHEL IST Specification, H-P-2-ASP-SP-0939, issue 3
- [RD02] Test Specification for HERSCHEL Instruments H-P-2-ASP-TS-1083
- [RD03] DCI HERSCHEL 10/501 31 issue 1 rev 2
- [RD04] HIFI EMC Susceptibility Criteria (TBD)
- [RD05] SPIRE EMC Susceptibility Criteria (TBD)
- [RD06] PACS EMC Susceptibility Criteria (TBD)

## 3. SYSTEM LEVEL FUNCTIONAL AND PERFORMANCE SUCCESS CRITERIA

The system level functioning and definition of performance success criteria is to be defined in consultation with the individual instrument technical specialists prior to the start of testing.

# HERSCHEL FM SPACECRAFT EMC TEST REQUIREMENT SPECIFICATION

REFERENCE : H-P-2-ASP-TS-0819

DATE : 10/08/2007

ISSUE : 3

PAGE : 8/80

---

The tests procedures for the instruments are referenced in RD02.



## 4. TEST ORGANIZATION AND RESPONSIBILITIES

### 4.1 Organization

The overall organization during the test is as follow:

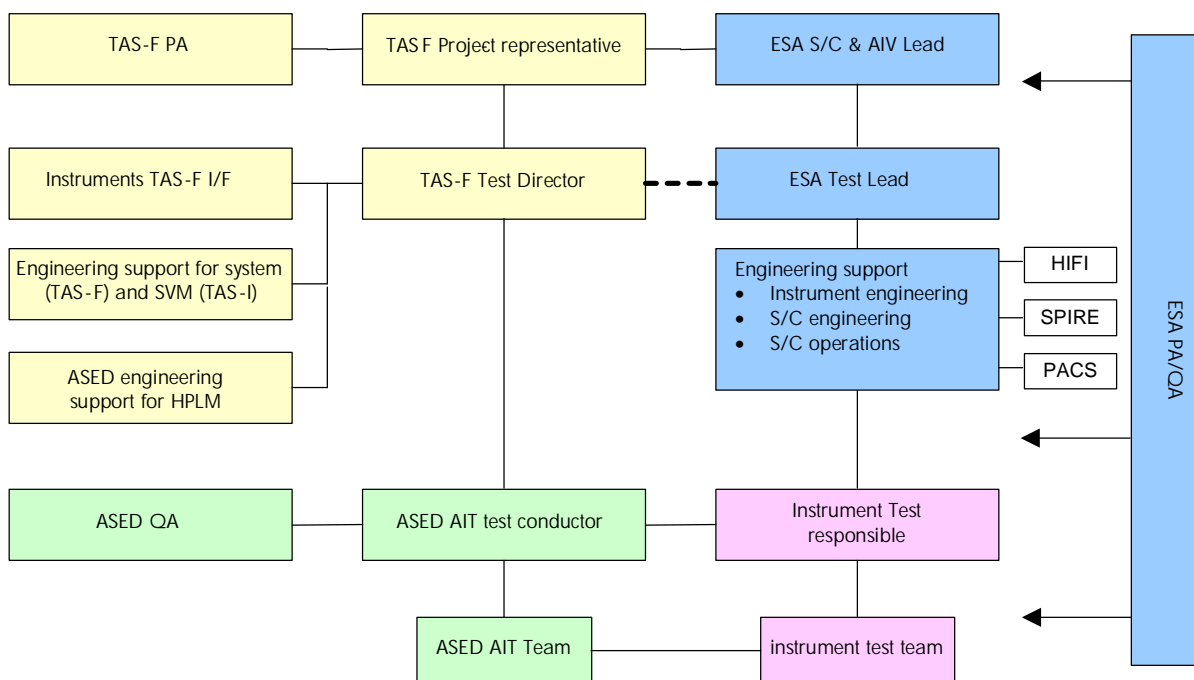

Figure 4-1: Test Organization

See next § for each actor responsibility definition.

### 4.2 Responsibilities

ASED is responsible for conducting the test.

The responsibilities linked to the test progress shall be mentioned in the ASED test leading procedure.

The overall responsibility during the test is as in following table.

# HERSCHEL FM SPACECRAFT EMC TEST REQUIREMENT SPECIFICATION

REFERENCE : H-P-2-ASP-TS-0819

DATE : 10/08/2007

ISSUE : 3

PAGE : 10/80

Organization	Responsibility
TAS-F Project Representative	Thales project interface Represents TAS-F during the test and he is also the I/F point with the ESA representative
TAS-F PA	TAS-F Project Assurance Manager
TAS-F Test Director	Issue the EMC test specification Go ahead for the test reviews (TRR, key point, PTR) Single point of contact with the TAS-F Evaluation team concerning the test result status.
ESA S/C and AIV Lead	ESA point of contact I/F with ESA project I/F with TAS-F test director & ESA Test Lead Go ahead for the test reviews (TRR, key point, PTR)
ESA Test Lead	Single point of contact with the ESA engineering support Go ahead for the test reviews (TRR, key point, PTR)
ESA Instruments I/F	I/F with TAS-F test director & instrument evaluation teams
ASED AIT test Conductor	Responsible of the ASED AIT Team Issue the leading procedure of all activities Manage all activities done during the test including "key point" meeting. I/F point with the Test Facility Team Responsible I/F point with the Instrument AIT Team Responsible Organise the Daily meeting Initialise NCR...
ASED AIT Team	Realise all S/C AIT activities within the arrival and the leaving Issue of the relevant test procedures Operate the GSE (except I-EGSE) Provide the test data Issue the test report.
Instruments TAS-F I/F	Issue section of the test specification relevant to the instrument. TAS-F instrument expert
SVM TAS-I engineering support	Provide to the TAS-F test director support w.r.t. the tests relevant to the SVM units
ASED QA	Organise the review (TRR/PTR...) Minute the running meeting (Key point)
Instrument AIT Team Responsible	I/F point with the ASED test conductor

Organization	Responsibility
	Provide relevant test data in order to help the test director concerning the "Key point" status.
Instrument AIT and Engineering Team	IEGSE full use Issue the relevant test procedures Process the instrument test data and Test data analysis Issue the test report.
Evaluation teams	Evaluate the EMC test results

## 4.3 Tasks breakdown and distribution

TAS-F is in charge of

- The satellite activities and test management:
- Responsible of the test specification
- Responsible of the final test evaluation report based on test report and inputs from the different test evaluation teams (SVM, HPLM, Instruments).

ASED is in charge of

- Preparation (tests definition, except for instruments) and execution
- S/C Cleaning, handling, mechanical mounting, electrical checkout, instruments modes set-up.
- Test management (reviews, leading procedure, daily meeting, key points, ...)
- Dedicated GSE installation/validations and use
- S/C data processing.
- Responsible of the test management and for interfaces between the HERSCHEL satellite and test facility.
- Running the PFM test
- Realize all S/C AIT activities within the arrival and the leaving
- Interfacing with TAS-I, ESTEC, AIT teams
- Preparation (tests definition, except for instruments) and execution
- Provide the test data
- Issue the test report.

HIFI/SPIRE/PACS is in charge of:

- Preparation, tests definition for the instruments

# HERSCHEL FM SPACECRAFT EMC TEST REQUIREMENT SPECIFICATION

REFERENCE : H-P-2-ASP-TS-0819

DATE : 10/08/2007

ISSUE : 3 PAGE : 12/80

---

- Dedicated GSE installation/validations and use (I.EGSE)
- Interpretation of instrument performance data
- Provide relevant test data analysis in order to help the test director concerning the "Key point" status.
- Provide assistance in case of major failure
- Participation to the test: instrument support to provide permanent presence during the duration of:
  - § The HIFI operations, plus support during test preparation (1 person on site, available on call)
  - § The SPIRE operation, plus support during test preparation (1 person on site, available on call).
  - § The PACS operation, plus support during test preparation (1 person on site, available on call).

# HERSCHEL FM SPACECRAFT EMC TEST REQUIREMENT SPECIFICATION

REFERENCE : H-P-2-ASP-TS-0819

DATE : 10/08/2007

ISSUE : 3

PAGE : 13/80

## 5. SPACECRAFT CONFIGURATION DURING TESTS

For these tests, 4 configurations are foreseen :

	Configuration 1	Configuration 2	Configuration 3	Configuration 4
	Nominal mode	Nominal mode	Nominal mode	Launch mode
EMC Tests	CE on PWR lines (in the max config) CS on RWLs (H-P-4-DS-RFD-023) RE of S/C RF Autocomp	RS of IST part1 (as RD01)  PACS / SPIRE	RS of IST part2 (as RD01)  HIFI	RE w.r.t. LV  RS w.r.t. LV
Power Panel				
CDMU	ON, NOM	ON, NOM	ON, NOM	ON, Standby
ACC	ON, Standby	ON, SCM	ON, SCM	ON, Standby
PCDU	ON	ON	ON	ON
Battery	Not connected	Not connected	Not connected	Not connected
TTC Panel				
EPC1	ON	ON	ON	OFF
TWT1	ON	ON	ON	OFF
EPC2	OFF	OFF	OFF	OFF
TWT2	OFF	OFF	OFF	OFF
XPND1	ON, RX + TX	ON, RX + TX	ON, RX + TX	ON, but only RX
XPND2	ON, but only RX	ON, but only RX	ON, but only RX	ON, but only RX
RFDN	/	/	/	/
AOCS sensors				
STR1	ON	ON	ON	OFF
STR2	OFF	OFF	OFF	OFF
CRS1	ON	ON	ON	ON
CRS2	ON	ON	ON	ON
RWL-1	ON	ON	ON	ON
RWL-2	ON	ON	ON	ON
RWL-3	ON	ON	ON	ON
RWL-4	ON	ON	ON	ON
GYRO A	ON	ON	ON	ON
GYRO B	OFF	OFF	OFF	OFF
SAS	/	/	/	/
AAD	/	/	/	/
Propulsion				

# HERSCHEL FM SPACECRAFT EMC TEST REQUIREMENT SPECIFICATION

REFERENCE : H-P-2-ASP-TS-0819

DATE : 10/08/2007

ISSUE : 3

PAGE : 14/80

PT	ON	ON	ON	ON
20N thrusters cat bed	OFF	OFF	OFF	OFF
Latch valve	OFF	OFF	OFF	OFF
Miscellaneous				
SREM	ON	ON	ON	OFF
VMC	ON	OFF	OFF	OFF
SPIRE Panel				
HSDPU N	ON	ON	ON	OFF
HSDPU R	OFF	OFF	OFF	OFF
HSFCU N	ON	ON	ON	OFF
HSFCU R	OFF	OFF	OFF	OFF
HSDCU N	ON	ON	ON	OFF
HSDCU R	OFF	OFF	OFF	OFF
CCU A	ON	ON	ON	OFF
CCU B	OFF	OFF	OFF	OFF
PACS Panel				
FPSPU N	ON	ON	ON	OFF
FPSPU R	OFF	OFF	OFF	OFF
FPDPU N	ON	ON	ON	OFF
FPDPU R	OFF	OFF	OFF	OFF
FPDEC/MEC1	ON	ON	ON	OFF
FPDEC/MEC2	OFF	OFF	OFF	OFF
FPBOLC N	ON	ON	ON	OFF
FPBOLC R	OFF	OFF	OFF	OFF
HIFI Panels				
FHWEH	ON	ON	ON	OFF
FHWEV	ON	ON	ON	OFF
FHLCU N	ON	ON	ON	OFF
FHLCU R	OFF	OFF	OFF	OFF
FHHRH	ON	ON	ON	OFF
FHHRV	ON	ON	ON	OFF
FHICU N	ON	ON	ON	OFF
FHICU R	OFF	OFF	OFF	OFF

For these configurations, the constraints for equipments shall be taken into account.

For example, thermal constraints can lead to use specific cooling system to have these S/C configurations.

# HERSCHEL FM SPACECRAFT EMC TEST REQUIREMENT SPECIFICATION

REFERENCE : H-P-2-ASP-TS-0819

DATE : 10/08/2007

ISSUE : 3 PAGE : 15/80

---

The STR1 shall be in tracking mode.

The EGSE harness between satellite and EGSE shall be shielded.

The SC configuration shall be defined precisely in the test procedure.

The compliance w.r.t. the grounding diagram (AD03) shall also be established. A scheme describing the EGSE grounding shall be included in the test procedure.

## 6. SPACECRAFT LEVEL EMC TESTS

The Spacecraft level EMC tests are defined in the HERSCHEL EMC specification [AD01], the specific requirements are extracted and presented in the following table.

§ EMC Specification	EMC Requirement	Subject	S/C configuration	Section
AD01, 3.2.2.3	EMCSYS-092	CE on power lines : * Common and Differential Mode : Time and frequency domain	1	7.1 7.2
AD01, 3.2.2.3	EMCSYS-096	CE on signal lines : * Common Mode : frequency domain	1	7.3 7.4
AD01, 3.2.2.3	EMCSYS-094	CS continuous on signal lines* : * Common Mode : frequency domain	1	7.5
AD01, 3.2.2.1.1	EMCSYS-050	RE E-field Narrowband in VEB plane in Launch Mode <b>(TBC)</b>	4	7.6
AD01, 3.2.2.1.1	EMCSYS-052	RE E-field Narrowband at UHF and C-band in Launch Mode <b>(TBC)</b>	4	7.7
AD01, 3.2.2.1.2.1	EMCSYS-060	RE E-field Narrowband in Operational Mode at 3 points around the HPLM from 14 kHz - 18 GHz	1	7.8
AD01, 3.1.3.1	EMCSYS-030	RS E-field in Launch Mode	4	7.9
AD01, 3.2.2.2.1	EMCSYS-070	RS E-field	2 & 3	7.10
		RS H-field transient	2	7.11
		RF auto-compatibility	1 & 4	7.12

\*This test is to be performed in case of unacceptable NC of CE tests on signal lines.

**Table 3.1-1: EMC Tests Overview**

Note(\*): For CE EMC tests it is possible to use a standard integration facility, however it will be necessary to conduct these tests with the SVM equipped with the PCDU. The tests shall therefore be conducted in frame of the SVM integration with the PLM PFM (without FPU TBC) and will therefore be formally done on satellite level. Testing during this integration phase does raise questions regarding the representativity affecting the test result, the feasibility of CE testing using the fully integrated FM spacecraft is TBC and will only be considered if test results during SVM/PLM integration indicate it is necessary.

All tests will be performed in the standard integration facility except for the following RE/RS which must be performed in an anechoic chamber;

- Spacecraft Radiated Emission in Launcher TC band
- Spacecraft Radiated Susceptibility to Launcher & Launch site Emissions
- PLM Radiated Environment
- PLM Radiated Susceptibility E-field



# HERSCHEL FM SPACECRAFT EMC TEST REQUIREMENT SPECIFICATION

REFERENCE : H-P-2-ASP-TS-0819

DATE : 10/08/2007

ISSUE : 3 PAGE : 17/80

---

- PLM Radiated Susceptibility H-field

## 7. TEST REQUIREMENT SHEETS

### 7.1 CE current on primary power lines towards PCDU

#### 7.1.1 Test objectives

The object of this test is to provide confirmation that PCDU module Conducted Emissions, measured on the primary power lines towards PCDU are compliant with specification.

This test is performed to fulfil EMC requirement EMCPLM-000 and EMCSYS-092 of HERSCHEL EMC Specification [AD01]

#### 7.1.2 Type of test

Conducted Emission : current

- Common Mode : Frequency domain
- Differential Mode : Time domain, Frequency domain

#### 7.1.3 Summary test definition

##### 7.1.3.1 Spacecraft Configuration

The Spacecraft configuration is configuration 1 as defined in chapter 5.

The Spacecraft must be fully integrated prior to the start of this test.

Test-Aids should be added on the measured lines (see Annex 1).

##### 7.1.3.2 Environment

This test is to be conducted at nominal room ambient temperature and pressure.

## 7.1.3.3 Test sequence

### 7.1.3.3.1 Background measurement - Spacecraft OFF / EGSE ON :

This measurement is performed to identify any emissions generated by the support or external power equipment.

### 7.1.3.4 Measurements Definition

The following lines shall be tested :

- CDMU (average current lower than 2A) (TBC)
- ACC (average current lower than 1A) (TBC)
- TWTA (average current lower than 3A)
- STR1 (average current lower than 1A)
- PACS/SPU (average current lower than 1.5A)
- PACS/DPU (average current lower than 2A)
- PACS/BOLC (average current lower than 2A)
- PACS/DECMEC (average current lower than 3A)
- CCU (average current lower than 1.5A)
- SPIRE/HSFCU (average current lower than 4A)
- HIFI/DPU-ICU (average current lower than 2A)
- HIFI/LCU (average current lower than 4A)

#### 7.1.3.4.1 Frequency domain

In the frequency range 30 Hz – 50 MHz, the conducted emission on power lines shall be deemed by comparison with unit test level results and assessed by the EMC team, i.e. representatives from ESA and TAS-F. In this frame a collection of the results got at unit level of the lines listed above shall be included in a dedicated technical note.

#### 7.1.3.4.2 Time Domain

The minimum bandwidth used for time domain measurement shall be 50MHz.

The expected current ripple shall be lower than 60mApp for nominal DC current less than 1Amp, to be relaxed by  $X\sqrt{I(Amp)}$  for nominal DC current upper to 1Amp.

## 7.1.3.5 Test conditions

### Test set-up and test support

The details of the test set-up will be contained within the corresponding test procedure

#### Facility :

Clean room

#### EGSE's :

CCS

Power SCOE

TM/TC SCOE

CDMU SCOE

TM/TC DFE

#### EMC test material :

Spectrum Analyser

Test aid

N.B.: Passive probes shall be preferred to active ones as far as possible.

## 7.1.4 Test acceptance criteria

See chapter 7.1.3.4

## 7.1.5 Responsibilities (see §7 of RD01)

Test specimen	ASED
Test Facility	ASED
Test Specification	TAS-F
Test Procedure	ASED
Test execution	ASED
Test Report	ASED
Test Evaluation	TAS-F

## 7.2 CE voltage on primary power lines towards PCDU

### 7.2.1 Test objectives

The object of this test is to provide confirmation that PCDU module Conducted Emissions, measured on the primary power lines towards PCDU are compliant with specification.

### 7.2.2 Type of test

Conducted Emission : voltage

- Differential mode : Time domain and in case of investigation Frequency domain

### 7.2.3 Summary test definition

#### 7.2.3.1 Spacecraft Configuration

The Spacecraft configuration is configuration 1 as defined in chapter 5.

The Spacecraft must be fully integrated prior to the start of this test.

Test-Aids should be added on the measured lines (see Annex 1).

#### 7.2.3.2 Environment

This test is to be conducted at nominal room ambient temperature and pressure.

#### 7.2.3.3 Test sequence

##### 7.2.3.3.1 Background measurement - Spacecraft OFF / EGSE ON :

This measurement is performed to identify any emissions generated by the support or external power equipment.

#### 7.2.3.4 Measurements Definition

The following line shall be tested :

- CDMU (average current lower than 2A) (TBC)
- ACC (average current lower than 1A) (TBC)
- TWTA (average current lower than 3A)

- STR1 (average current lower than 1A)
- PACS/SPU (average current lower than 1.5A)
- PACS/DPU (average current lower than 2A)
- PACS/BOLC (average current lower than 2A)
- PACS/DECMEC (average current lower than 3A)
- CCU (average current lower than 1.5A)
- SPIRE/HSFCU (average current lower than 4A)
- HIFI/DPU-ICU (average current lower than 2A)
- HIFI/LCU (average current lower than 4A)

The minimum bandwidth used for measurement shall be 50MHz.

## 7.2.4 Test set-up and test support

The details of the test set-up will be contained within the corresponding test procedure

### Facility :

Clean room

### EGSE's :

CCS

Power SCOE

TM/TC SCOE

CDMU SCOE

TM/TC DFE

### EMC test material :

Oscilloscope

Test aid

N.B.: Passive probes shall be preferred to active ones as far as possible.

## 7.2.5 Test acceptance criteria

the conducted emission voltage on power lines shall be deemed by comparison with unit/SVM test level results and assessed by the EMC team, i.e. representatives from ESA and TAS-F. In this frame a collection of the results got at unit/SVM level of the lines listed above shall be included in a dedicated technical note.

# HERSCHEL FM SPACECRAFT EMC TEST REQUIREMENT SPECIFICATION

REFERENCE : H-P-2-ASP-TS-0819

DATE : 10/08/2007

ISSUE : 3 PAGE : 23/80

---

A successful test result is achieved when the measured voltage emission at all locations is 6 dB below the unit susceptibility limit.

## 7.2.6 Responsibilities (see §7 of RD01)

Test specimen	ASED
Test Facility	ASED
Test Specification	TAS-F
Test Procedure	ASED
Test execution	ASED
Test Report	ASED
Test Evaluation	TAS-F

## 7.3 CE current on signal lines

### 7.3.1 Test objectives

The object of this test is to check that the conducted current emissions on ACC-RWL signal lines TD and TOCO are compliant with specification.

This test is performed to fulfil EMC requirement EMCSYS-096 of HERSCHEL EMC Specification [AD01]

### 7.3.2 Type of test

Conducted Emission : current

- Common Mode : Frequency domain

### 7.3.3 Summary test definition

#### 7.3.3.1 Spacecraft Configuration

The Spacecraft configuration is configuration 1 as defined in chapter 5.

The Spacecraft must be fully integrated prior to the start of this test.

Test-Aids should be added on the measured lines (see Annexes 2 & 3).

#### 7.3.3.2 Environment

This test is to be conducted at nominal room ambient temperature and pressure.

#### 7.3.3.3 Test sequence

##### 7.3.3.3.1 Background measurement - Spacecraft OFF / EGSE ON :

This measurement is performed to identify any emissions generated by the support or external power equipment.

#### 7.3.3.4 Measurements Definition

The following signal lines shall be tested :

- Torque Command



- Torque Direction

#### 7.3.3.4.1 Frequency domain

In the frequency range 30 Hz – 50 MHz, the conducted emission on signal lines shall not exceed 77 dBuA rms.

#### 7.3.3.5 Test conditions

Test set-up and test support

The details of the test set-up will be contained within the corresponding test procedure

Facility :

Clean room

EGSE's :

CCS

Power SCOE

TM/TC SCOE

CDMU SCOE

TM/TC DFE

EMC test material :

Spectrum Analyser

Test aid

#### 7.3.4 Test acceptance criteria

See chapter 7.3.3.4

#### 7.3.5 Responsibilities (see §7 of RD01)

Test specimen	ASED
Test Facility	ASED
Test Specification	TAS-F
Test Procedure	ASED
Test execution	ASED
Test Report	ASED
Test Evaluation	TAS-F

## 7.4 CE voltage ripple on signal lines

### 7.4.1 Test objectives

The object of this test is to check that the conducted voltage emissions on ACC-RWL signal lines TD and TOCO are within the values measured at sub system level.

This test is performed to fulfil EMC requirement EMCSYS-096 of HERSCHEL EMC Specification [AD01]

### 7.4.2 Type of test

Conducted Emission : voltage

- Common Mode : Time and Frequency (only in case of investigation) domain

### 7.4.3 Summary test definition

#### 7.4.3.1 Spacecraft Configuration

The Spacecraft configuration is configuration 1 as defined in chapter 5.

The Spacecraft must be fully integrated prior to the start of this test.

Test-Aids should be added on the measured lines (see Annexes 2 & 3).

#### 7.4.3.2 Environment

This test is to be conducted at nominal room ambient temperature and pressure.

#### 7.4.3.3 Test sequence

##### 7.4.3.3.1 Background measurement - Spacecraft OFF / EGSE ON :

This measurement is performed to identify any emissions generated by the support or external power equipment.

#### 7.4.3.4 Measurements Definition

The following signal lines shall be tested :

- Torque Command
- Torque Direction

The minimum bandwidth used for measurement shall be 50MHz.

#### 7.4.3.5 Test conditions

##### Test set-up and test support

The details of the test set-up will be contained within the corresponding test procedure

##### Facility :

Clean room

##### EGSE's :

CCS

Power SCOE

TM/TC SCOE

CDMU SCOE

TM/TC DFE

##### EMC test material :

Digital Oscilloscope

Test aid

#### 7.4.4 Test acceptance criteria

The expected voltage ripple shall be lower than 300mVpp.

#### 7.4.5 Responsibilities (see §7 of RD01)

Test specimen	ASED
Test Facility	ASED
Test Specification	TAS-F
Test Procedure	ASED
Test execution	ASED
Test Report	ASED
Test Evaluation	TAS-F

## 7.5 CS voltage on signal lines (to be performed in case of NC with CE tests)

### 7.5.1 Test objectives

The object of this test is to check if relevant CE tests are not successful, that the ACC-RWL signal lines TD and TOCO present no risk of susceptibility when submitted to the levels specified in [AD01] EMCEQ-650.

This test is performed to fulfil EMC requirement EMCSYS-094 of HERSCHEL EMC Specification [AD01]

### 7.5.2 Type of test

Conducted Susceptibility: voltage

- Common mode : Time domain

### 7.5.3 Summary test definition

#### 7.5.3.1 Spacecraft Configuration

The Spacecraft configuration is configuration 1 as defined in chapter 5.

The Spacecraft must be fully integrated prior to the start of this test.

Test-Aids should be added on the measured lines (see Annexes 2 & 3).

#### 7.5.3.2 Environment

This test is to be conducted at nominal room ambient temperature and pressure.

#### 7.5.3.3 Test sequence

##### 7.5.3.3.1 TLM read out without noise injection :

The TLM values shall be monitored at RWL side without injecting any noise.

The ToCo command shall be set to 500 leading to a read out close to 0.5105V.

#### 7.5.3.4 Measurements Definition

The following line shall be tested :

- Torque Command
- Torque Direction

All along the tests sequence the TLM read out monitoring shall be recorded.

#### 7.5.3.4.1 Injected signal levels

The injected signal level shall be at least 6 dB higher than the measured conducted emission values as per paragraph 7.4.

In the frequency range 50kHz – 50 MHz, the injected voltage should not exceed 2 Vpp either on the signal or the AGND line.

**WARNING:** In any case, even if the wanted injected level is not reached the imposed current has to be monitored and it should not exceed 100 mApp at injection point.

#### 7.5.3.5 Test conditions

##### Test set-up and test support

The details of the test set-up will be contained within the corresponding test procedure

##### Facility :

Clean room

##### EGSE's :

CCS

Power SCOE

TM/TC SCOE

CDMU SCOE

TM/TC DFE

##### EMC test material :

Synthesisers

Amplifiers

Spectrum Analyser

Digital Oscilloscope

Multimeter

Test aid

B.O.B.

## 7.5.4 Test acceptance criteria

The RWL shall not exhibit any failures malfunctions or unintended responses when submitted to the injected signals.

The motor current TLM shall keep inside the range  $\pm 12.5$  mV around the value without noise injection when submitted to the injected signals.

## 7.5.5 Responsibilities (see §7 of RD01)

Test specimen	ASED
Test Facility	ASED
Test Specification	TAS-F + TBD for ACC
Test Procedure	ASED
Test execution	ASED
Test Report	ASED
Test Evaluation	TAS-F

## 7.6 ***RE E-field Narrowband at VEB plane in Launch Mode (TBC)***

### 7.6.1 Test objectives

The object of this test is to provide confirmation that the integrated spacecraft Radiated Emissions in launch mode, measured at the VEB plane are compliant with the launcher (Ariane requirements).

This test is performed to fulfil EMC requirement EMCSYS-050 of HERSCHEL EMC Specification [AD01]

### 7.6.2 Type of test

Radiated Emission, E-field.

### 7.6.3 Summary test definition

#### 7.6.3.1 Spacecraft Configuration

The Spacecraft configuration is configuration 4 as defined in chapter 5.

The Spacecraft must be fully integrated prior to the start of this test.

The precise orientation of the spacecraft will be included in the corresponding test procedure. The satellite shall be installed on the integration Dolly.

The on-board antennas shall be replaced by dummy loads in order to limit the spurious radiation at TX frequency. The dummy loads shall be capable to handle the TX power without constraints. The wiring between the satellite and the EGSE shall be specifically shielded with Al foil (to be integrated before start of test).

#### 7.6.3.2 Environment

This test is to be conducted at nominal room ambient temperature and pressure.

Due to the low noise levels being measured and to avoid external noise pollution of the results, this test must be conducted in a suitably equipped anechoic chamber.

#### 7.6.3.3 Test sequence

##### 7.6.3.3.1 Ambient measurement - Spacecraft OFF / EGSE ON :

This measurement is performed to identify any emissions generated by the support or external power equipment.

Position the receiving antenna at a distance of 1m from the spacecraft surface in front of the power panel and perform the Radiated Emission measurement Electric field in the frequency range 14kHz to 18 GHz.

#### 7.6.3.3.2 Spacecraft powered ON to launch mode :

During this Radiated emission test all on-board equipment that is normally operating during the Launch phase must be operated in its normal mode that is considered to be the most emissive (most power consuming).

##### 7.6.3.3.2.1 Pre-launch configuration – Spacecraft powered by LPS

The spacecraft configuration shall be as defined in RD01, §TBD.

Position the receiving antenna at a distance of 1m from the spacecraft surface at a position that best simulates the VEB plane separation interface and measure the Radiated Emission Electric field over the frequency range 14kHz to 18 GHz

The exact measurement position will be proposed in the corresponding test procedure

##### 7.6.3.3.2.2 Launch configuration – Spacecraft powered by its internal battery power or battery simulator

For this configuration the battery simulator shall be preferred to the internal battery excepted for any non acceptable spurious recorded which need additional measurements.

The spacecraft configuration shall be as defined in RD01, §TBD. Prior to execution of this test, in case of use of the internal battery, the battery shall be fully charged. The spacecraft setup and dummy run can be performed using SAS power.

When powered by internal battery the overall test duration must not exceed 2 hours

Position the receiving antenna at a distance of 1m from the spacecraft surface at a position that best simulates the VEB plane separation interface and measure the Radiated Emission Electric field over the frequency range 14kHz to 18 GHz

The exact measurement position will be proposed in the corresponding test procedure



7.6.3.4 Measurements Definition

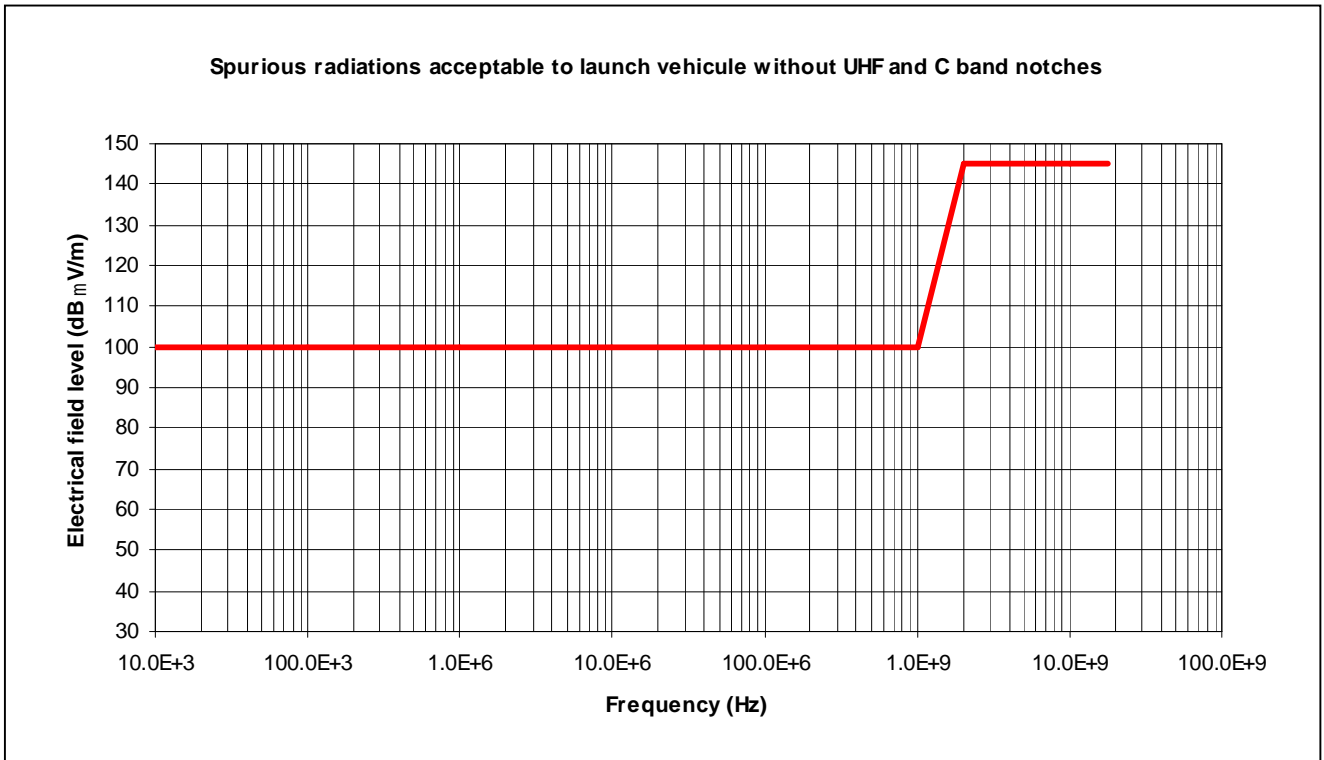

The specified RE-E field levels are shown in the above figure.

Note: The measurement bandwidth used for the measurement shall comply with §3.2.4.4 of [AD01] as follows :

The measurement receiver bandwidths listed below shall be used for emission testing. These bandwidths are specified at the 6 dB down points for the overall selectivity curve of the receivers.

Frequency range	Maximum 6 dB Bandwidth
30 Hz – 1 kHz	10 Hz
1 kHz – 10 kHz	100 Hz
10 kHz – 150 kHz	1 kHz
150 kHz – 30 MHz	10 kHz
30 MHz – 1 GHz	100 kHz
Above 1 GHz	1 MHz

## 7.6.3.5 Number of measurements

Number of measurements = number of antenna positions (1V + 1H above 30 MHz) X 3 configurations (Spacecraft OFF Ambient, Spacecraft ON pre-launch, Spacecraft On Launch) X number of discrete frequency bands(1 - swept) = 6

## 7.6.4 Test set-up and test support

The details of the test set-up will be contained within the corresponding test procedure

### Facility :

Anechoic Chamber

### EGSE's :

CCS

Power SCOE

TM/TC SCOE

CDMU SCOE

TM/TC DFE

### EMC test material :

Suitable Antenna for measurement over 14kHz to 18GHz

Low Noise Amplifier

Spectrum Analyser with pre-selector

## 7.6.5 Test acceptance criteria

The measured Radiated Emissions shall be less than the limit curve shown in §7.6.3.4

## 7.6.6 Responsibilities (see §7 of RD01)

Test specimen	ASED
Test Facility	ASED
Test Specification	TAS-F
Test Procedure	ASED
Test execution	ASED
Test Report	ASED
Test Evaluation	TAS-F

## 7.7 **RE E-field Narrowband at UHF and C-band in Launch Mode (TBC)**

### 7.7.1 Test objectives

The object of this test is to provide confirmation that the integrated spacecraft Radiated Emissions in launch mode in the UHF and C-band notches, measured at the VEB plane are compliant with the launcher (Ariane requirements).

This test is performed to fulfil EMC requirement EMCSYS-052 of HERSCHEL EMC Specification [AD01]

### 7.7.2 Type of test

Radiated Emission, E-field.

### 7.7.3 Summary test definition

#### 7.7.3.1 Spacecraft Configuration

The Spacecraft configuration is configuration 4 as defined in chapter 5.

The Spacecraft must be integrated prior to the start of this test.

The precise orientation of the spacecraft will be included in the corresponding test procedure. The satellite shall be installed on the integration Dolly.

The on-board antennas shall be replaced by dummy loads in order to limit the spurious radiation at TX frequency. The dummy loads shall be capable to handle the TX power without constraints. The wiring between the satellite and the EGSE shall be specifically shielded with Al foil (to be integrated before start of test).

#### 7.7.3.2 Environment

This test is to be conducted at nominal room ambient temperature and pressure.

Due to the low noise levels being measured and to avoid external noise pollution of the results, this test must be conducted in a suitably equipped anechoic chamber.

#### 7.7.3.3 Test sequence

##### 7.7.3.3.1 Ambient measurement - Spacecraft OFF / EGSE ON :

This measurement is performed to eliminate any emissions generated by the support or external power equipment.

Position the receiving antenna at a distance of 1m from the spacecraft surface in front of the power panel and perform the Radiated Emission measurement Electric field in the UHF frequency band 420MHz to 480 MHz and C-band 5450MHz to 5825MHz

#### 7.7.3.3.2 Spacecraft powered ON to launch mode :

During this Radiated emission test all on-board equipment that is normally operating during the Launch phase must be operated in its normal mode that is considered to be the most emissive (most power consuming).

##### 7.7.3.3.2.1 Pre-launch configuration – Spacecraft powered by LPS

The spacecraft configuration shall be as defined in RD01, §TBD.

Position the receiving antenna at a distance of 1m from the spacecraft surface at a position that best simulates the VEB plane separation interface and measure the Radiated Emission Electric field over the UHF frequency band 420MHz to 480 MHz and C-band 5450MHz to 5825MHz

The exact measurement position will be proposed in the corresponding test procedure

##### 7.7.3.3.2.2 Launch configuration – Spacecraft powered by its internal battery power or battery simulator

For this configuration the battery simulator shall be preferred to the internal battery excepted for any non acceptable spurious recorded which need additional measurements.

The spacecraft configuration shall be as defined in RD01, §TBD. Prior to execution of this test, the battery shall be fully charged. The spacecraft setup and dummy run can be performed using SAS power.

When powered by internal battery the overall test duration must not exceed 2 hours

Position the receiving antenna at a distance of 1m from the spacecraft surface at a position that best simulates the VEB plane separation interface and measure the Radiated Emission Electric field over the UHF frequency band 420MHz to 480 MHz and C-band 5450MHz to 5825MHz

The exact measurement position will be proposed in the corresponding test procedure

## 7.7.3.4 Measurements Definition

The specified RE-E field levels are as follows;

- UHF band 420MHz to 480 MHz = < 35dB $\mu$ V/m
- C- band 5450MHz to 5825MHz = < 70dB $\mu$ V/m

Note: The measurement device shall be able to detect emissions which can be at least 6 dB lower than the specified limit level.

## 7.7.3.5 Number of measurements

Number of measurements = number of antenna positions (1V + 1H) X 3 configurations (Spacecraft OFF Ambient, Spacecraft ON pre-launch, Spacecraft On Launch) X number of discrete frequency bands(2) = 12

## 7.7.4 Test set-up and test support

The details of the test set-up will be contained within the corresponding test procedure

### Facility :

Anechoic Chamber

### EGSE's :

CCS

Power SCOE

TM/TC SCOE

CDMU SCOE

TM/TC DFE

### EMC test material :

Suitable Antenna for UHF measurement

Suitable Antenna for C-band measurement

Low Noise Amplifier

Spectrum Analyser with pre-selector

## 7.7.5 Test acceptance criteria

The specified measured RE-E field levels at the VEB plane must be within the following limit;

- UHF band 420MHz to 480 MHz = < 35dB $\mu$ V/m

# HERSCHEL FM SPACECRAFT EMC TEST REQUIREMENT SPECIFICATION

REFERENCE : H-P-2-ASP-TS-0819

DATE : 10/08/2007

ISSUE : 3 PAGE : 38/80

---

- C- band 5450MHz to 5825MHz = < 70dB $\mu$ V/m

## 7.7.6 Responsibilities (see §7 of RD01)

Test specimen	ASED
Test Facility	ASED
Test Specification	TAS-F
Test Procedure	ASED
Test execution	ASED
Test Report	ASED
Test Evaluation	TAS-F

## 7.8 RE E-field Narrowband in Operational Mode

### 7.8.1 Test objectives

The object of this test is to provide confirmation that the integrated spacecraft Radiated Emissions in operational mode, measured at several positions around the spacecraft cryostat are within acceptable limits.

This information will be used in determining the system level RE/RS compatibility margins

This test is performed to fulfil EMC requirement EMCSYS-060 of HERSCHEL EMC Specification [AD01]

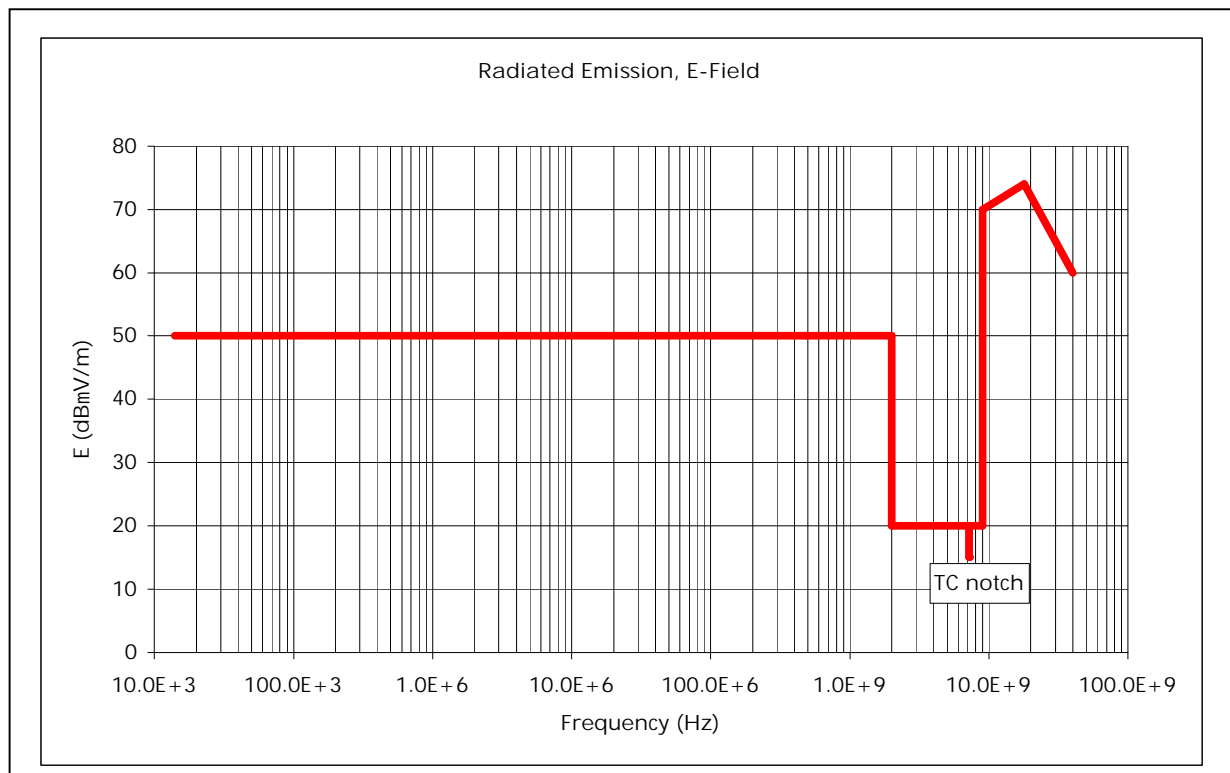

### 7.8.2 Type of test

Radiated Emission, E-field.

### 7.8.3 Summary test definition

#### 7.8.3.1 Spacecraft Configuration

The Spacecraft configuration is configuration 1, as defined in chapter 5, laying on dolly GSE.

The Spacecraft must be fully integrated prior to the start of this test.

The precise orientation of the spacecraft will be included in the corresponding test procedure.

The on-board antennas shall be replaced by dummy loads in order to limit the spurious radiation at TX frequency. The dummy loads shall be able to handle the TX power without constraints. The wiring between the satellite and the EGSE shall be specifically shielded with Al foil (to be integrated before start of test).

### 7.8.3.2 Environment

This test is to be conducted at nominal room ambient temperature and pressure.

Due to the low noise levels being measured and to avoid external noise pollution of the results, this test must be conducted in a suitably equipped anechoic chamber.

### 7.8.3.3 Test sequence

A test measurement is to be made at each of three separate locations around the HPLM, these locations are to be chosen to coincide with the position of the cryo harness and waveguides (alternatively any positions where maximum levels of emissions are considered likely). The exact positions will be proposed in the corresponding test procedure.

#### 7.8.3.3.1 Ambient measurement - Spacecraft OFF / EGSE ON :

This measurement is performed to identify any emissions generated by the support or external power equipment.

Position the receiving antenna at a distance of 1m from the spacecraft surface at each of the measurement positions. At each position measure the ambient background Radiated Emission Electric field over the frequency range 14kHz to 18 GHz.

The exact measurement positions will be proposed in the corresponding test procedure

#### 7.8.3.3.2 Spacecraft powered ON to Operational mode :

During this Radiated emission test all on-board equipment that is normally operating during the Operational phase must be operated in its normal mode that is considered to be the most emissive (most power consuming). The three HERSCHEL instruments are normally ON together with one or two instruments operating, the other(s) one in standby so this will be the operational mode for this test.

##### 7.8.3.3.2.1 All instruments ON

The spacecraft configuration shall be as defined in RD01, §TBD.

With the spacecraft operating in its normal operational mode select the instruments into the following condition PACS & SPIRE & HIFI ON



For all the spectrum from 14kHz to 18 GHz excepted in the TC notch:

Position the receiving antenna at a distance of 1m from the spacecraft surface towards the SPIRE side (HERSCHEL payload upper sub platform in -Z towards -X by 20°) and measure the Radiated Emission Electric field over this frequency range.

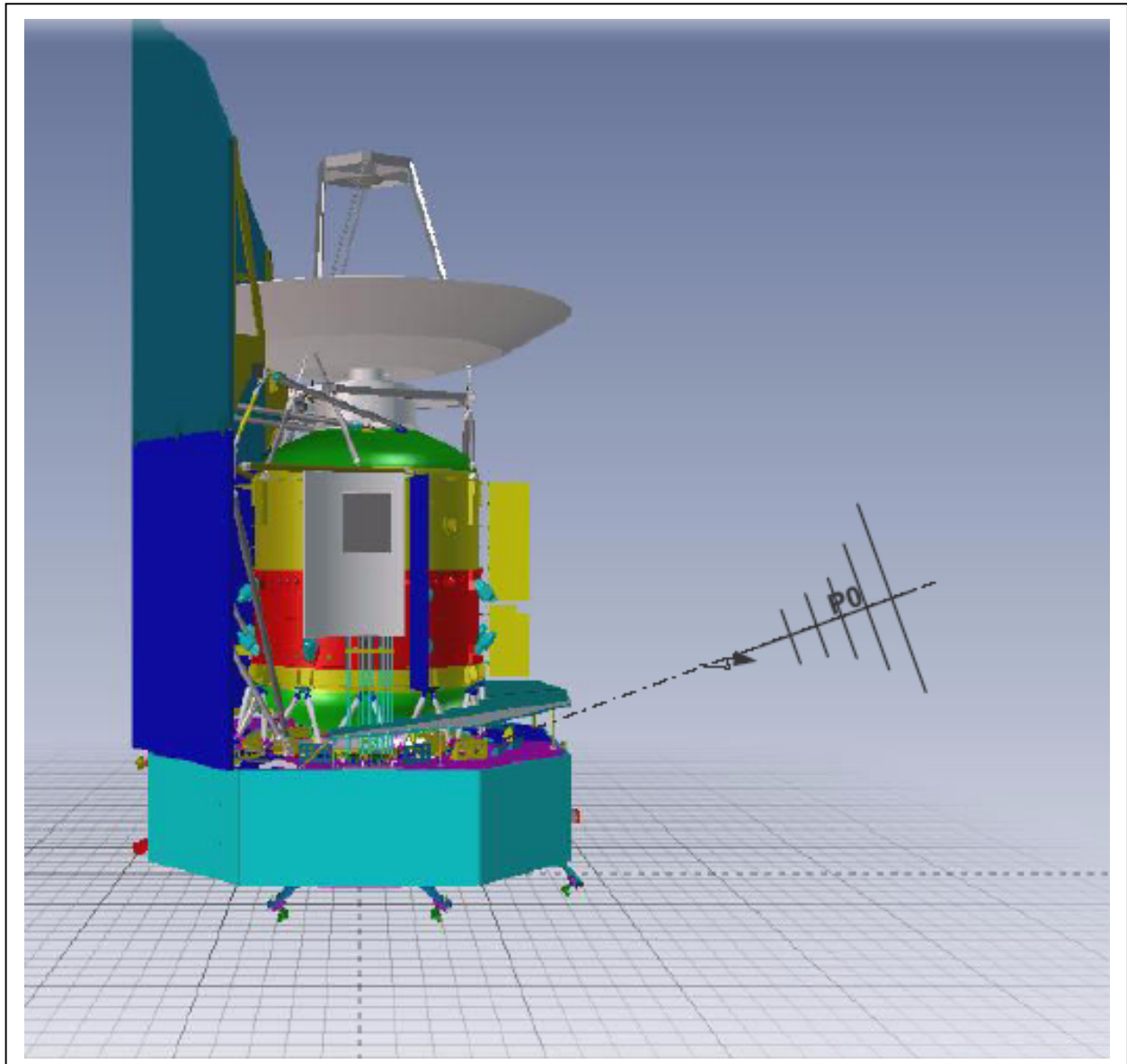

For the specific TC notch:

Position the receiving antenna at a distance of 1m from the spacecraft surface at one of the predefined positions (P1 in +Z towards -X by 20°) around the HPLM and measure the Radiated Emission Electric field over the frequency range of the telecommand receiver. Repeat the measurement for the other predefined position (P2 in -Z towards -X by 20°).

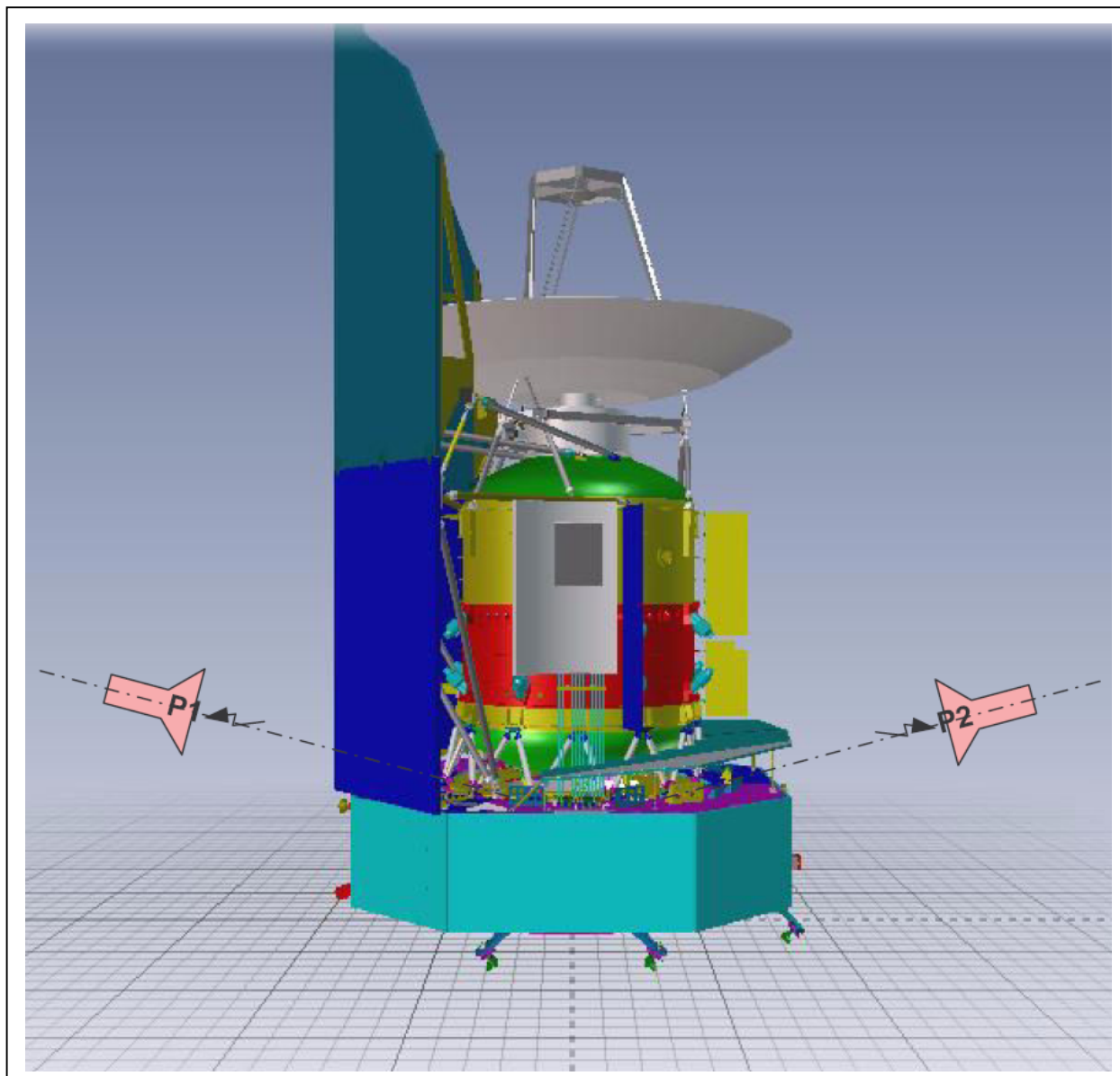

### 7.8.3.4 Measurements Definition

The measurements taken during this test are to be used to determine the overall compatibility of the instruments with each other and with the SVM, as such there is no limit directly applicable to this measurement.

Note: For the TC notch, the measurement device shall be able to detect emissions which can be at least 10 dB lower than the specified limit level:

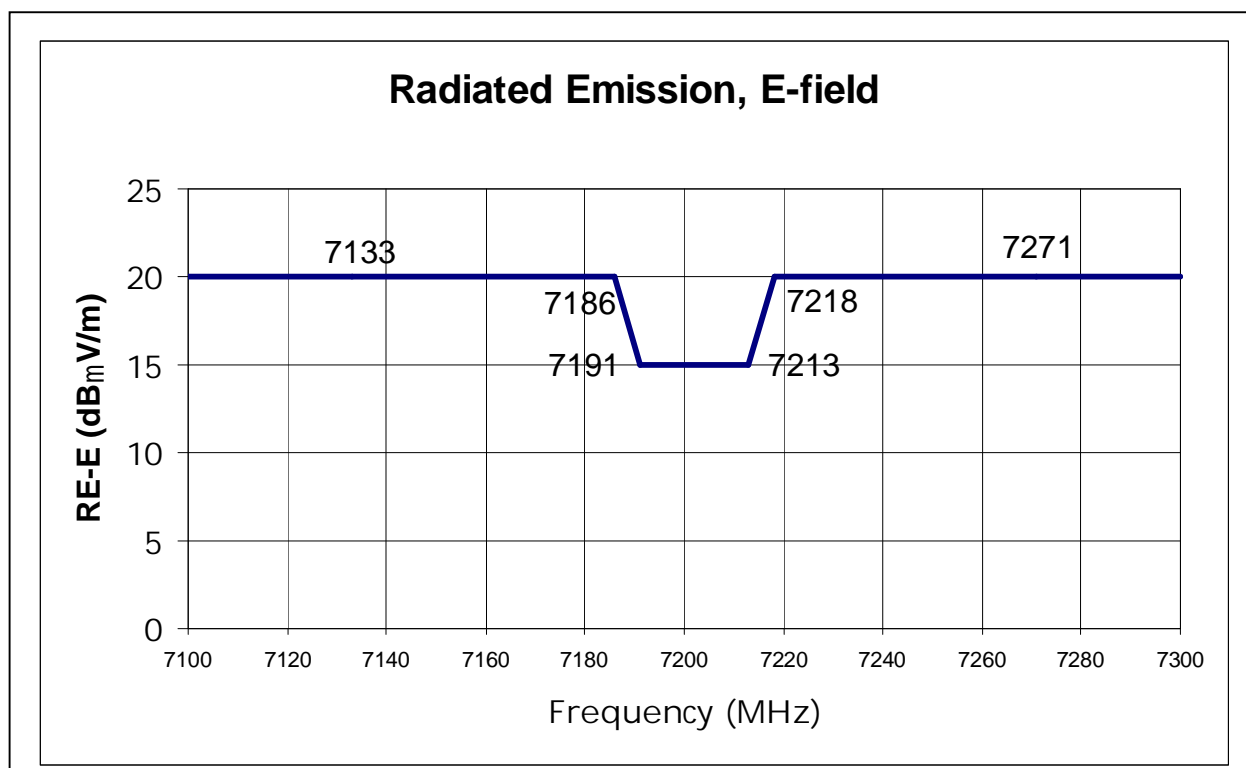

### 7.8.3.5 Number of measurements

Number of measurements = number of antenna positions (2V+2H) X 2 configurations (Spacecraft OFF(ambient), PACS & SPIRE & HIFI ON) X number of discrete frequency bands(1 - swept) = 8

### 7.8.4 Test set-up and test support

The details of the test set-up will be contained within the corresponding test procedure

Facility :

Anechoic Chamber

EGSE's :

CCS

Power SCOE

TM/TC SCOE

CDMU SCOE

TM/TC DFE

EMC test material :

Suitable Antenna for measurement over 14kHz to 18GHz

Low Noise Amplifier

Spectrum Analyser with pre-selector

## 7.8.5 Test acceptance criteria

Excepted for the TC notch, there is no test acceptance criteria, this is a measurement that will be used to derive the overall system RE/RS compatibility margin.

## 7.8.6 Responsibilities (see §7 of RD01)

Test specimen	ASED
Test Facility	ASED
Test Specification	TAS-F
Test Procedure	ASED
Test execution	ASED
Test Report	ASED
Test Evaluation	TAS-F

## 7.9 Spacecraft Radiated Susceptibility to Launcher & Launch site Emissions

### 7.9.1 Test objectives

The object of this test is to provide confirmation that the integrated spacecraft when operated in its Launch/pre-Launch mode is not susceptible to the Radiated Emissions coming from either the Launch vehicle or the Launch Site.

This test is performed to fulfil EMC requirement EMCSYS-30 of HERSCHEL EMC Specification [ADO1].

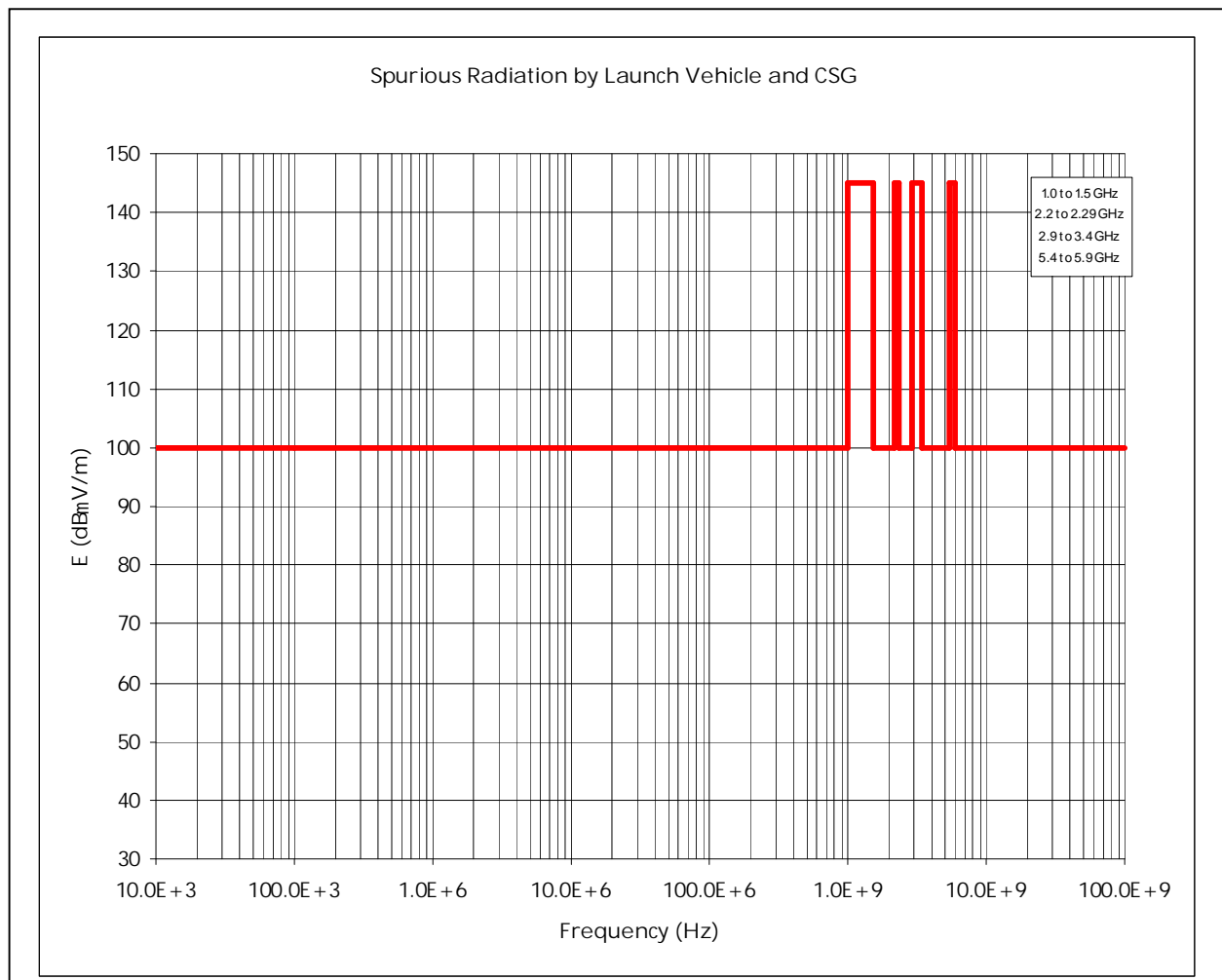

## 7.9.2 Type of test

Radiated Susceptibility, E-field.

## 7.9.3 Summary test definition

### 7.9.3.1 Spacecraft Configuration

The Spacecraft configuration is configuration 4 as defined in Chapter 5.

The Spacecraft must be fully integrated prior to the start of this test.

The precise orientation of the spacecraft will be included in the corresponding test procedure. The satellite shall be installed on the integration Dolly.

The on-board antennas shall be replaced by dummy loads in order to limit the spurious radiation at TX frequency. The dummy loads shall be capable to handle the TX power without constraints. The wiring between the satellite and the EGSE shall be specifically shielded with Al foil (to be integrated before start of test).

The spacecraft shall be powered by the battery simulator

### 7.9.3.2 Environment

This test is to be conducted at nominal room ambient temperature and pressure.

Due to the Electric field levels generated during this test it must be conducted in a suitably equipped anechoic chamber.

### 7.9.3.3 Test sequence

#### 7.9.3.3.1 Susceptibility in Launch/Ascent Mode

The susceptibility threshold of the spacecraft is to be verified in its Launch/Ascent operating mode, that is with all onboard systems ON that are normally operated during launch in their most susceptible mode (lowest power / most sensitive) and with all instruments OFF.

Position the transmitting antenna at the maximum distance permitted by the illumination means from the spacecraft surface (3 to 5 meters) directed towards the separation interface and generate the specified Electric field over the frequency range 14kHz to 18 GHz , apply the specified modulation to the field. Repeating the test at the higher field strengths specified for the Telemetry notches. The distance between antenna position and spacecraft shall be defined in the test procedure and the calibration done accordingly.

## 7.9.3.4 Measurements Definition

The following sinus E-Field test levels shall be used during this test;

Launch/Ascent mode:

0.1V/m over the frequency range 14kHz (TBC) to 18GHz

18V/m over the frequency range 1.0GHz to 1.5GHz

18V/m over the frequency range 2.2GHz to 2.29GHz

18V/m over the frequency range 2.9GHz to 3.4GHz

18V/m over the frequency range 5.4GHz to 5.9GHz

The following Modulation shall be applied during this test;

1kHz squarewave, 30% amplitude modulation

Note: The test requirement must be met for both Horizontally and Vertically polarised fields.

(deleted)

## 7.9.3.5 Number of measurements

Number of measurements = number of antenna positions (1V + 1H) X 1 configuration (Spacecraft Launch/ascent mode) X number of discrete frequency bands(10) = 20 (TBC)

## 7.9.4 Test set-up and test support

The details of the test set-up will be contained within the corresponding test procedure

Facility :

Anechoic Chamber

EGSE's :

CCS

Power SCOE (batsim)

TM/TC SCOE

CDMU SCOE

TM/TC DFE

## EMC test material :

Spacecraft illumination:

Synthesisers

Amplifiers

Double ridged horn/suitable field generating antenna

Specified field level monitoring:

Field probe or second double ridged horn

Appropriate receiving system (spectrum analyser if second antenna is used)

## 7.9.5 Test acceptance criteria

The Acceptance criterion for this test is that the Specified E-field test levels are achieved at the surface of the spacecraft AND there are no detected malfunctions or degradation in performance of the on-board spacecraft systems. Telemetry parameters to be cross-checked shall be defined in the test procedure.

During the EMC tests the system shall be fully operative to have the conditions with respect to the characteristics to be measured.

## 7.9.6 Responsibilities (see §7 of RD01)

Test specimen	ASED
Test Facility	ASED
Test Specification	TAS-F
Test Procedure	ASED
Test execution	ASED
Test Report	ASED
Test Evaluation	TAS-F + instruments



## 7.10 Spacecraft PLM Radiated Susceptibility E-field

### 7.10.1 Test objectives

The object of this test is to provide confirmation that the integrated spacecraft when operated in its Operational modes is not susceptible to the specified levels of E-Field Radiated Emissions.

This test is performed to fulfil EMC requirement EMCSYS-070 of HERSCHEL EMC Specification [AD01]

### 7.10.2 Type of test

Radiated Susceptibility, E-field.

### 7.10.3 Summary test definition

#### 7.10.3.1 Spacecraft Configurations

The Spacecraft configurations are configuration 2 and 3 as defined in Section 5.

The Spacecraft must be fully integrated prior to the start of this test.

The precise orientation of the spacecraft will be included in the corresponding test procedure.

The on-board antennas shall be replaced by dummy loads in order to limit the spurious radiation at TX frequency. The dummy loads shall be capable to handle the TX power without constraints. The wiring between the satellite and the EGSE shall be specifically shielded with Al foil (to be integrated before start of test).

#### 7.10.3.2 Environment

This test is to be conducted at nominal room ambient temperature and pressure.

Due to the Electric field levels generated during this test it must be conducted in a suitably equipped anechoic chamber.

### 7.10.3.3 Test sequence

A test measurement is to be made at each of two separate locations around the HPLM, these locations are to be chosen to coincide with the position of the cryo harness and waveguides (alternatively positions where maximum susceptibility effects are considered likely). The exact positions will be proposed in the corresponding test procedure.

#### 7.10.3.3.1 Susceptibility in Operational Mode

The susceptibility threshold of the spacecraft is to be verified in each of its normal operating modes, that is with all onboard systems operated in their most susceptible mode (lowest power / most sensitive) and with 2 configurations of instruments SPIRE in prime mode or HIFI in prime mode (TBC).

## 7.10.3.3.1.1 SPIRE prime mode or HIFI prime(TBC)

With the spacecraft operating in its normal operational mode select the instruments into the following condition SPIRE in prime mode or HIFI prime mode (TBC).

For all the spectrum from 14kHz to 18 GHz:

Position the transmitting antenna at the maximum distance permitted by the illumination means (3 to 5m) from the spacecraft surface towards the cryo harness side (HERSCHEL payload upper sub platform in -Z towards +X by 20°) and generate the specified Electric field over the frequency range 14kHz to 18 GHz , apply the specified modulation to the field.

Throughout the test all instruments and all on-board systems are to be continuously monitored for signs of malfunction or degraded performance.

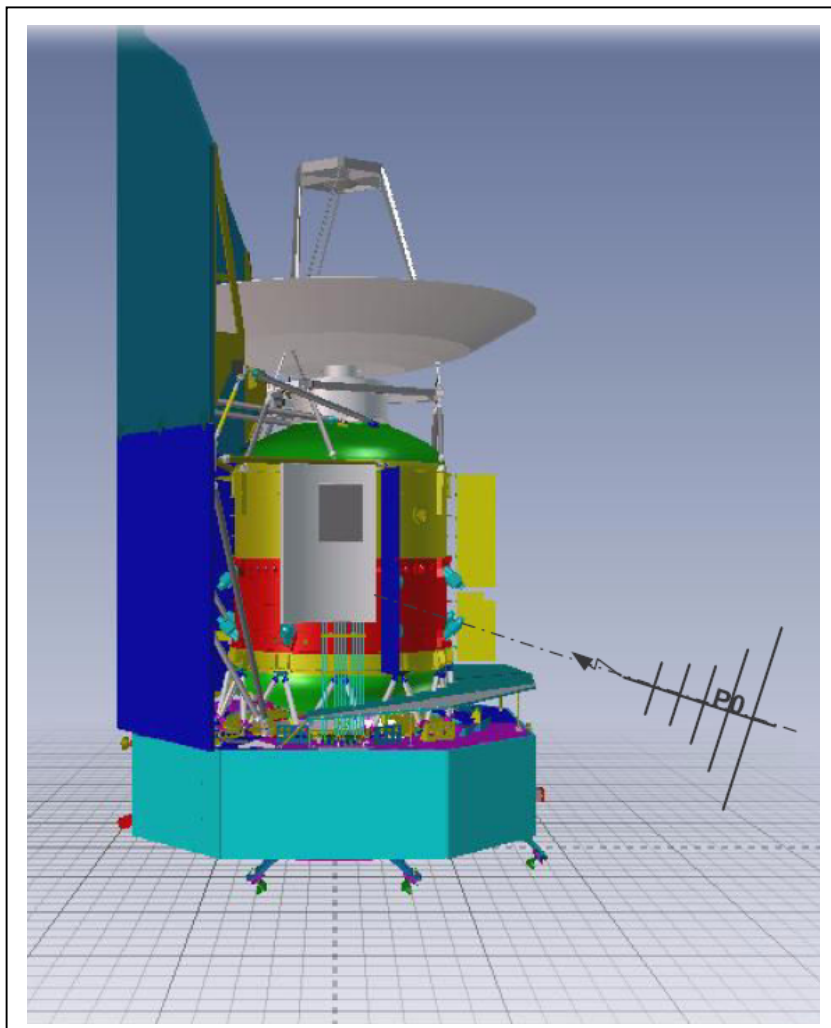

## 7.10.3.4 Measurements Definition

The following sinus E-Field test levels shall be used during this test;

- MAX between [Radiated Emission measured + 6 dB] and [60 dB $\mu$ V/m], Level will be defined after RE test over the frequency range 14kHz to 18 GHz

## 7.10.3.5 Number of measurements

Number of measurements in PO = number of antenna positions (1V + 1H) X 1 configurations (1 Spacecraft operational mode) X number of discrete frequency bands(10) = 20 TBC

## 7.10.4 Test set-up and test support

The details of the test set-up will be contained within the corresponding test procedure

### Facility :

Anechoic Chamber

### EGSE's :

CCS

Power SCOE

TM/TC SCOE

CDMU SCOE

TM/TC DFE

### EMC test material :

Spacecraft illumination:

Synthesisers

Amplifiers

Double ridged horn/suitable field generating antenna

Specified field level monitoring:

Field probe or second double ridged horn

Appropriate receiving system (spectrum analyser if second antenna is used)

## 7.10.5 Test acceptance criteria

The Acceptance criterion for this test is that the Specified E-field test levels are achieved at the surface of the spacecraft AND there are no detected malfunctions or degradation in performance of the on-board spacecraft systems or instruments.

Instruments susceptibility criteria : see RD04, RD05 and RD06.

During the EMC tests the system shall be fully operative to have the conditions with respect to the characteristics to be measured.

The success criteria during susceptibility test is the correct functioning of the instruments and the stability of the housekeeping and scientific data.

The evaluation of the stability of scientific data is performed as defined here after : see RD04, RD05 and RD06.

## 7.10.6 Responsibilities (see §7 of RD01)

Test specimen	ASED
Test Facility	ASED
Test Specification	TAS-F
Test Procedure	ASED
Test execution	ASED
Test Report	ASED
Test Evaluation	TAS-F + instruments

## 7.11 Spacecraft PLM Radiated Susceptibility transient magnetic field

### 7.11.1 Test objectives

The object of this test is to provide confirmation that the integrated spacecraft when operated in its Normal Operational mode is not susceptible to transient magnetic field generated by the solar array.

### 7.11.2 Type of test

Radiated Susceptibility, H-field transient.

### 7.11.3 Summary test definition

#### 7.11.3.1 Spacecraft Configuration

The Spacecraft configuration is configuration 2 as defined in Chapter 5.

The Spacecraft must be fully integrated prior to the start of this test.

The precise orientation of the spacecraft will be included in the corresponding test procedure.

The on-board antennas shall be replaced by dummy loads in order to limit the spurious radiation at TX frequency. The dummy loads shall be capable to handle the TX power without constraints. The wiring between the satellite and the EGSE shall be specifically shielded with Al foil (to be integrated before start of test).

#### 7.11.3.2 Environment

This test is to be conducted at nominal room ambient temperature and pressure.

#### 7.11.3.3 Test sequence

The antenna position will be defined in test procedure.

This position shall be chosen to coincide with the position of solar array panel 3 in +Y +Z.

## 7.11.3.3.1 Susceptibility in Operational Mode

The susceptibility threshold of the spacecraft is to be verified in each of its normal operating modes, that is with all onboard systems operated in their most susceptible mode (lowest power / most sensitive) and with instrument PACS/photometer in prime mode.

## 7.11.3.4 Measurements Definition

A specific antenna shall be defined in the test procedure able to generate transient magnetic field up to 500 kHz (TBC) following the spectrum defined hereafter. The current pulse shall have a rising/falling time of 3 us, a time duration of 100 us and a period of 0.3ms (TBC). The amplitude of the current pulse shall be tuned in order to reach the spectrum defined.

The following H-field tests transient spectrum levels is expected to be during this test (TBC):

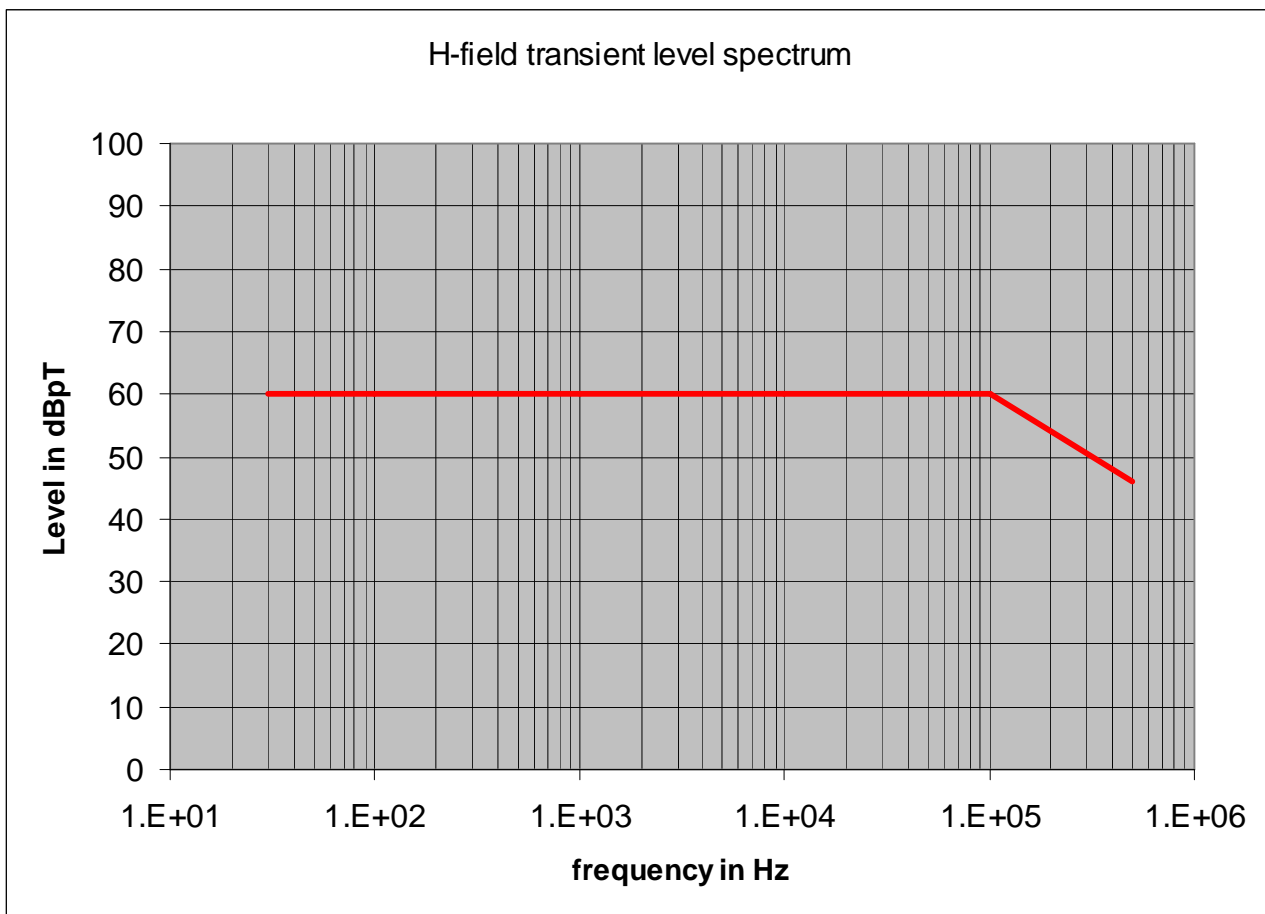

## 7.11.3.5 Number of measurements

Number of measurements = number of antenna positions (1) X 1 configurations (1 Spacecraft operational modes) X number of discrete frequency bands(1 - swept) = 1 TBC

## 7.11.4 Test set-up and test support

The details of the test set-up will be contained within the corresponding test procedure

### Facility :

Anechoic Chamber

### EGSE's :

CCS

Power SCOE

TM/TC SCOE

CDMU SCOE

TM/TC DFE

### EMC test material :

Spacecraft illumination:

Pulse current generator

Amplifiers

Suitable field generating antenna

Specified field level monitoring:

Suitable frequency magnetic Field probe

Appropriate receiving system (spectrum analyser)

## 7.11.5 Test acceptance criteria

The Acceptance criterion for this test is that the Specified H-field test levels are achieved at the surface of the spacecraft AND there are no detected malfunctions or degradation in performance of the on-board spacecraft systems or instruments.

PACS susceptibility criteria : see RD06

During the EMC tests the system shall be fully operative to have the conditions with respect to the characteristics to be measured.

The success criteria during susceptibility test is the correct functioning of PACS and the stability of the housekeeping and scientific data.



# HERSCHEL FM SPACECRAFT EMC TEST REQUIREMENT SPECIFICATION

REFERENCE : H-P-2-ASP-TS-0819

DATE : 10/08/2007

ISSUE : 3 PAGE : 57/80

---

The evaluation of the stability of scientific data is performed as defined here after : see RD06.

## 7.11.6 Responsibilities (see §7 of RD01)

Test specimen	ASED
Test Facility	ASED
Test Specification	TAS-F
Test Procedure	ASED
Test execution	ASED
Test Report	ASED
Test Evaluation	TAS-F + instruments

## 7.12 Spacecraft RF auto-compatibility

### 7.12.1 Test objectives

The object of this test is to demonstrate that with a fully equipped and integrated spacecraft and with communications made through antennas, the following performances are satisfied :

- While all the equipments of the spacecraft are operated or simulated in their most relevant perturbing modes, the X-band transponder subsystem is able to :
  - Receive telecommands at the lowest level which shall be experienced at L2 position.
  - Support low bit rate telecommand acquisition under 125 Hz Doppler effect at required level
  - Receive and transmit a ranging signal which can be properly measured. It will be verified that with delay results are compatible with the ranging calibrations gathered at transponder subsystem level.
  
- While the satellite is emitting its telemetry signals through all required antennas, all the other equipment of the satellite are functioning properly.

### 7.12.2 Summary test definition

#### 7.12.2.1 Spacecraft Configuration

The Spacecraft must be fully integrated prior to the start of this test. All the antennas shall be connected and the tested antennas shall have an open radiation field of view.

#### 7.12.2.2 Environment

Anechoic chamber.

## 7.12.2.3 Test sequence

The following configuration and test sequence shall be applied :

1. The Herschel satellite shall be fully integrated in an EMC representative configuration with all its antennas mechanically installed and electrically connected.
2. The RF-EGSE shall be connected to the satellite as shown in Figure 1. The following links shall be established and calibrated in order to derive from measurements by RF-EGSE the TC and TM carriers levels at antennas interfaces :
  - TC Uplinks connected to the two Rx flight test couplers
  - TM Downlinks connected to the two Tx flight test couplers

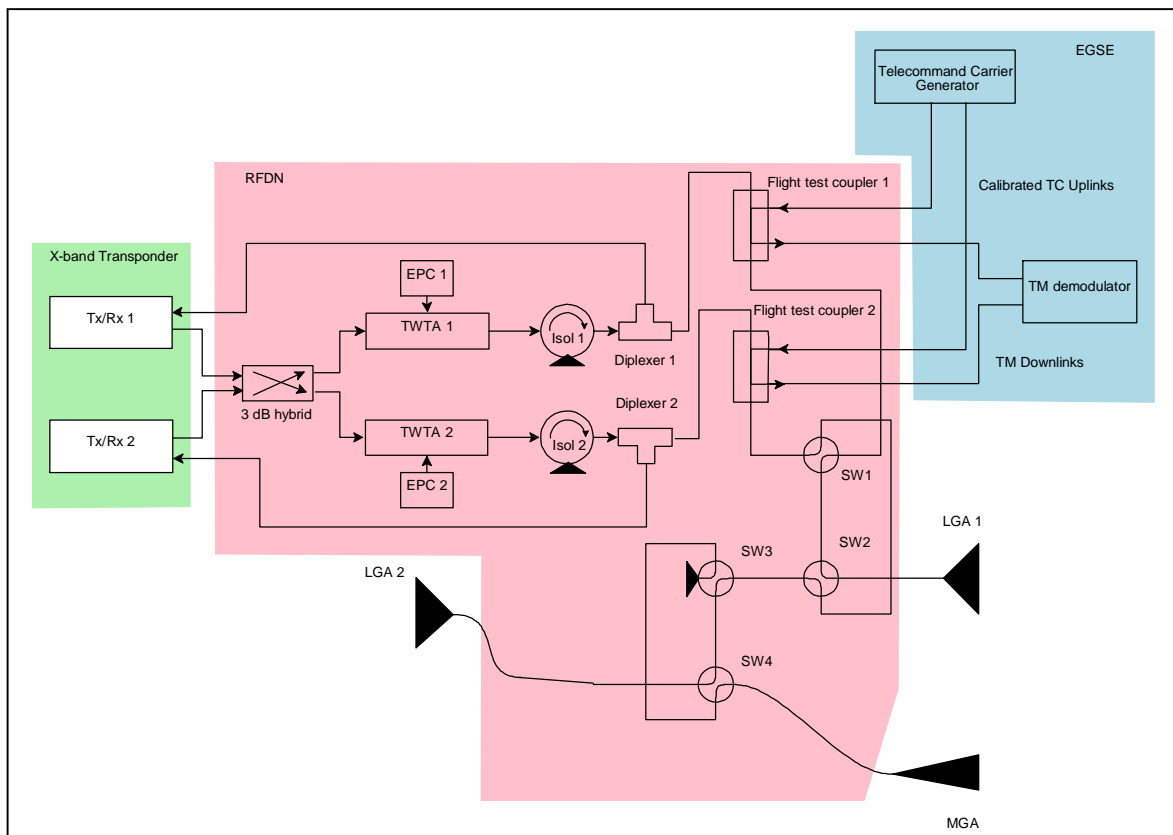

Figure 7-1 RF-EGSE and TTC Subsystem interconnection

3. Set the Herschel Satellite in the launch configuration given in Tableau 1.

# HERSCHEL FM SPACECRAFT EMC TEST REQUIREMENT SPECIFICATION

REFERENCE : H-P-2-ASP-TS-0819

DATE : 10/08/2007

ISSUE : 3

PAGE : 60/80

## Satellite state

CDMS mode	launch	note:		ACMS mode	stand by
TM/OBT	A	Rx rate	125bps (1)	OBT, PM & SW	A- A1N [B1S]
PM & SW	A1 [B1]	TM rate	150kbps (1)	CRS / FDIR	1A, 2S / AFS
SCBP / MTL	0 / OFF	Tx chain	T.1(RF OFF) A.OFF(LCL ON)	GYROs	A,B,C IF 1 ON
FDIR / SrvCBH	AFS / N only	Rx 1 Ant.	LGA1	STRs	OFF
launch straps	all present	Rx 2 Ant.	LGA2	RWs	OFF
PCDU	IF A ON	CCU	A, B ON 8s-Hk	LV enable	OFF
Battery	VEOC max	SPIRE	OFF	RCS enable	OFF
Power Source	UMB	HIFI	OFF	SREM	OFF
Mass Memory	3 banks	PACS	OFF	VMC	OFF

## GSE support

Power source	BS	TC source	UMB 4kbps	ENV simulator	stand by
--------------	----	-----------	-----------	---------------	----------

Tableau 1 Satellite launch configuration

# HERSCHEL FM SPACECRAFT EMC TEST REQUIREMENT SPECIFICATION

REFERENCE : H-P-2-ASP-TS-0819

DATE : 10/08/2007

ISSUE : 3

PAGE : 61/80

Configure the RFDN switches in mode 1 to ensure that RX1 is nominally connected to the LGA1 antenna, RX2 is connected to LGA2 and MGA is on load. This configuration will be made according the guidelines of the RFDN user's handbook and X-band transponder user manual which are synthesized in Tableau 2 (LGA3 doesn't exist in Herschel config).

Mode	Switches position				D/L path		U/L path		
	SW1	SW2	SW3	SW4	TWTA1	TWTA2	LGA1	LGA2/3	MGA
1	A	A	A	A	LGA1	LGA2/3	RX1	RX2	LOAD
2	A	A	A	B	LGA1	MGA	RX1	LOAD	RX2
3	A	A	B	A	LGA1	MGA	RX1	LOAD	RX2
4	A	A	B	B	LGA1	LGA2/3	RX1	RX2	LOAD
5	A	B	A	A	LGA2/3	LGA1	RX2	RX1	LOAD
6	A	B	A	B	MGA	LGA1	RX2	LOAD	RX1
7	A	B	B	A	MGA	LGA1	RX2	LOAD	RX1
8	A	B	B	B	LGA2/3	LGA1	RX2	RX1	LOAD
9	B	A	A	A	LGA2/3	LGA1	RX2	RX1	LOAD
10	B	A	A	B	MGA	LGA1	RX2	LOAD	RX1
11	B	A	B	A	MGA	LGA1	RX2	LOAD	RX1
12	B	A	B	B	LGA2/3	LGA1	RX2	RX1	LOAD
13	B	B	A	A	LGA1	LGA2/3	RX1	RX2	LOAD
14	B	B	A	B	LGA1	MGA	RX1	LOAD	RX2
15	B	B	B	A	LGA1	MGA	RX1	LOAD	RX2
16	B	B	B	B	LGA1	LGA2/3	RX1	RX2	LOAD

Tableau 2 RFDN Modes

- a) For each of the following configurations of Rx-Antennas : (Rx1,LGA1), (Rx2, LGA2) perform the following TC carrier acquisition tests through the relevant flight test coupler.
- Determination of the minimum level of an unmodulated TC carrier at the antenna interface which entails the carrier acquisition by the flight receiver. This level will be derived from signal generator level corrected by uplink calibration.  
Success criteria for (RX1,LGA1) is a level lower than  
 $-140 + 1.19 = -138.81$  dBm  
Success criteria for (RX2,LGA2) is a level lower than  
 $-140 + 1.57 = -138.43$  dBm (TBC)
  - Measure of the minimum level of an unmodulated TC carrier affected by 100 Hz/s over +/- 65 kHz Doppler frequency variation around Herschel U/L nominal frequency at the antenna interface which entails the carrier acquisition by the flight receiver. This level will be derived from signal generator level corrected by uplink calibration.  
Success criteria for (RX1,LGA1) is a level lower than  
 $-140 + 1.19 = -138.81$  dBm  
Success criteria for (RX2,LGA2) is a level lower than  
 $-140 + 1.57 = -138.43$  dBm (TBC)
- b) For the following configurations of Rx-Antennas : (Rx1,LGA1), (Rx2, LGA1 & LGA2) perform the following 4000 bps TC carrier decoding tests through the relevant flight test coupler.
- Determination of the minimum level of a 4000 bps 1 rad pk modulated TC carrier at the antenna interface which entails the correct telecommand decoding by the flight receiver of a stream of 100 TC. This level will be derived from signal generator level corrected by uplink calibration.  
Success criteria for (RX1,LGA1) is a level lower than  
 $-137 + 1.19 = -135.81$  dBm  
Success criteria for (RX2,LGA2) is a level lower than  
 $-137 + 1.57 = -135.43$  dBm (TBC)
  - Measure of the minimum level of a 4000 bps 1 rad pk modulated TC carrier affected by 100 Hz/s over +/- 65 kHz Doppler frequency

variation around Herschel U/L nominal frequency at the antenna interface which entails the correct telecommand decoding acquisition by the flight receiver of a stream of 100 TC. This level will be derived from signal generator level corrected by uplink calibration.

Success criteria for (RX1,LGA1) is a level lower than

$$-120 + 1.19 = -118.81 \text{ dBm}$$

Success criteria for (RX2,LGA2) is a level lower than

$$-120 + 1.57 = -118.43 \text{ dBm (TBC)}$$

#### 4. Set the Satellite in nominal configuration given in Tableau 3

Note that this has to be achieved in various steps, and the appropriate transitions shall be performed (see RDO1).

Satellite state

CDMS mode	NOM	note:		ACMS mode	SCM (OBS)
TM/OBT	A	Rx rate	4kbps	OBT, PM & SW	A- A1N [B1S]
PM & SW	A1 [B1]	TM rate	150kbps	CRS / FDIR	1A, 2S / AFO
SCBP / MTL	4 / ON	Tx chain	T.1 A.A MGA	GYROs	A,B,C IF 1 ON
FDIR / SrvCBH	AFO / N only	Rx 1 Ant.	MGA	STRs	A (LCL B ON)
launch straps	none	Rx 2 Ant.	LGA1	RWs	1,2,3,4 ON
PCDU	IF A ON	CCU	A,B ON Hk	LV enable	ON, A open
Battery	charged (BS)	SPIRE	STBY	RCS enable	ON A CBH ON
Power Source	SAS	HIFI	STBY	SREM	OFF
Mass Memory	≥ 1 banks	PACS	SPECTRO	VMC	OFF

GSE support

Power source	SAS 1475W	TC source	MGA	ENV simulator	closed loop
--------------	-----------	-----------	-----	---------------	-------------

Tableau 3 Satellite in nominal configuration

Configure the RFDN switches in mode 6 to ensure that RX1 and TWTA 1 are nominally connected to the MGA antenna and RX2 is connected to LGA1. This configuration will be made according the guidelines of the RFDN user's handbook and X-band transponder user manual which are synthesized in Tableau 2.

a) For each of the following configurations of Rx-Antennas : (Rx2,LGA1), (Rx1,MGA) perform the following TC carrier acquisition tests through the relevant flight test coupler

- Determination of the minimum level of an unmodulated TC carrier at the antenna interface which entails the carrier acquisition by the flight receiver. This level will be derived from signal generator level corrected by uplink calibration.

Success criteria for (RX2,LGA1) is a level lower than

$$-140 + 1.19 = -138.81 \text{ dBm}$$

Success criteria for (RX1,MGA1) is a level lower than

$$-140 + 1.19 = -138.81 \text{ dBm}$$

- Measure of the minimum level of an unmodulated TC carrier affected by 100 Hz/s over +/- 65 kHz Doppler frequency variation around Herschel U/L nominal frequency at the antenna interface which entails the carrier acquisition by the flight receiver. This level will be derived from signal generator level corrected by uplink calibration.

Success criteria for (RX2,LGA1) is a level lower than

$$-137 + 1.19 = -135.81 \text{ dBm}$$

Success criteria for (RX1,MGA1) is a level lower than

$$-137 + 1.19 = -135.81 \text{ dBm}$$

b) For the following configurations of Rx-Antennas : (Rx2,LGA1), (Rx1,MGA), perform the following 4000 bps TC carrier decoding tests and ranging measurement through the relevant flight test coupler.

- Determination of the minimum level of a 4000 bps 1 rad pk modulated TC carrier at the antenna interface which entails the correct telecommand decoding by the flight receiver of a stream of 100 TC. This level will be derived from signal generator level corrected by uplink calibration.

Success criteria for (RX2,LGA1) is a level lower than

$$-120 + 1.19 = -118.81 \text{ dBm}$$

Success criteria for (RX1,MGA1) is a level lower than



$$-120 + 1.19 = -118.81 \text{ dBm}$$

- Measure of the minimum level of a 4000 bps 1 rad pk modulated TC carrier affected by a 100 Hz/s over +/- 65 kHz Doppler frequency variation around Herschel U/L nominal frequency at the antenna interface which entails the correct telecommand decoding acquisition by the flight receiver of a stream of 100 TC. This level will be derived from signal generator level corrected by uplink calibration.

Success criteria for (RX2,LGA1) is a level lower than

$$-140 + 1.19 = -138.81 \text{ dBm}$$

Success criteria for (RX1,MGA1) is a level lower than

$$-140 + 1.19 = -138.81 \text{ dBm}$$

- Ranging measurement with modulated tones. During this test, the effective ranging group delay shall be measured for -105 dBm U/L power. The TT&C SCOE and XPND configuration shall be :

RNG U/L M.I. = 0.7 rad pk

RNG tone frequency = 698.26 kHz

RNG code = 0

RNG D/L M.I: = 0.6 rad pk

Coherent Mode ON

The measured group delay shall be as shown in the two following tables with an accuracy of 30 ns.

Antenna	Group delay at -105 dBm (ns)
LGA1	5203.41
LGA2	5201.77
MGA	5183.18

Table 1 Ranging Group delay specification at  $f_t=698.26$  kHz on chain 1

Antenna	Group delay at -105 dBm (ns)
LGA1	5153.98
LGA2	5163.42
MGA	5140.41

Table 2 Ranging Group delay specification at  $f_i=698.26$  kHz on chain 2

## 5. RF susceptibility test :

The TM emission in an open field of view is only possible through the LGA2 antenna as the fields of view of LGA1 and MGA are blocked by the dolly mechanical structure.

### Satellite state

CDMS mode	NOM	note:		ACMS mode	SCM (OBS)
TM/OBT	A	Rx rate	4kbps	OBT, PM & SW	A- A1N [B1S]
PM & SW	A1 [B1]	TM rate	150kbps	CRS / FDIR	1A, 2S / AFO
SCBP / MTL	4 / ON	Tx chain	TWTA2 ON/TWTA1 OFF	GYROs	A,B,C IF 1 ON
FDIR / SrvCBH	AFO / N only	Rx 1 Ant.	MGA	STRs	A (LCL B ON)
launch straps	none	Rx 2 Ant.	LGA1	RWs	1,2,3,4 ON
PCDU	IF A ON	CCU	A,B ON Hk	LV enable	ON, A open
Battery	charged (BS)	SPIRE	STBY	RCS enable	ON A CBH ON
Power Source	SAS	HIFI	STBY	SREM	OFF
Mass Memory	≥ 1 banks	PACS	SPECTRO	VMC	OFF

### GSE support

Power source	SAS 1475W	TC source	MGA	ENV simulator	closed loop
--------------	-----------	-----------	-----	---------------	-------------

Tableau 4 Satellite configuration for RF susceptibility test

Set the satellite in nominal configuration shown in Tableau 4

Configure the RFDN switches in mode 1 to ensure that RX1 is nominally connected to the LGA1 antenna, RX2 is connected to LGA2 and MGA is on load.

Switch ON the TWTA 2 which will feed LGA2.

Keep TWTA 1 switched off.

Verify the health status of the spacecraft in each of its normal operating modes. In this objective all instruments and all on-board systems are to be continuously monitored for signs of malfunction or degraded performance.

### 7.12.3 Test set-up and test support

The details of the test set-up will be contained within the corresponding test procedure

Facility :

Anechoic Chamber

EGSE's :

CCS

Power SCOE (batsim)

TM/TC SCOE

CDMU SCOE

TM/TC DFE

### 7.12.4 Test acceptance criteria

The Acceptance criterion for this test is that there are no detected malfunctions or degradation in performance of the on-board spacecraft systems or instruments.

### 7.12.5 Responsibilities (see §7 of RD01)

Test specimen	ASED
Test Facility	ASED
Test Specification	TAS-F

# HERSCHEL FM SPACECRAFT EMC TEST REQUIREMENT SPECIFICATION

REFERENCE : H-P-2-ASP-TS-0819

DATE : 10/08/2007

ISSUE : 3 PAGE : 68/80

---

Test Procedure	ASED + TAS-I
Test execution	ASED + TAS-I
Test Report	ASED
Test Evaluation	TAS-F

## 8. ABBREVIATIONS

AAD :	Attitude Anomaly Detector
ACC :	Attitude Control Computer
AD :	Applicable Document
AIT :	Assembly Integration Test
AOCS :	Attitude Orbital Control System
AVM :	Avionics Model
BB :	Broadband
BEU :	Back End Unit
BOL :	Beginning of life
BOLC :	Bolometer Controller
BW :	Bandwidth
4K CAU :	4K Cooler Auxiliary Unit
4K C C Reg :	4K Cooler Current Regulator
4K CDE :	4K Cooler Drive Electronics
4K CCU :	4K Cooler Compressor Unit
CCS :	Control Checkout System
CDMU :	Central Data Management Unit
CE :	Conducted Emission
CM :	Common Mode
CQM :	Cryogenic Qualification Model
CRS :	Coarse Rate Sensor
CS :	Conducted Susceptibility
CSG :	Centre Spatial Guyanais
CSL :	Centre Spatial de Liège
DAE :	Data Acquisition Electronic
DB :	Dismounting Bracket
DC :	Direct Current
DCCU :	Dilution Cooler Control Unit
DECMEC :	Detector & Mechanism Controllers
DM :	Differential Mode
DPU :	Data Processing Unit
EGSE :	Electrical Ground Support Equipment
EMC :	Electromagnetic Compatibility
EMI :	Electromagnetic Interference

# HERSCHEL FM SPACECRAFT EMC TEST REQUIREMENT SPECIFICATION

REFERENCE : H-P-2-ASP-TS-0819

DATE : 10/08/2007

ISSUE : 3 PAGE : 70/80

---

EPC :	Electrical Power Conditionner
EQM :	Engineering and Qualification Model
ESA :	European Space Agency
FIRST :	Far InfraRed and Submillimeter Telescope
FM :	Flight Model
FOG :	Fiber Optic Gyro
FPU :	Focal Plane Unit
HFI :	High Frequency Instrument
HIFI :	Heterodyne Instrument for FIRST
IAS :	Institut d'Astrophysique Spatial
ICU :	Instrument Control Unit
IID :	Instrument Interface Document
ISO :	Infrared Space Observatory
JFET :	Junction Field Effect Transistors
LCL :	Latch Current Limiter
LFI :	Low Frequency Instrument
LGA :	Low Gain Antenna
LPS :	Launch Power System
LV :	Launch vehicle
MGA :	Medium Gain Antenna
NB :	Narrowband
PA :	Product Assurance
PACS :	Photoconductor Array Camera and Spectrometer (FIRST)
PCDU :	Power Conditioning and Distribution Unit
PFM :	ProtoFlight Model
PLM :	Payload Module
PT :	Pressure Transducer
RD :	Reference Document
REBA :	Radiometric Electronic Box Assembly
RE-E :	Radiated Emission E-field
RE-H :	Radiated Emission H-field
REU :	Read out Electronic Unit
RF :	Radio Frequency
RFDN :	Radio Frequency Distribution Network
r.m.s. :	Root Mean Square
RS-E :	Radiated Susceptibility E-field
RS-H :	Radiated Susceptibility H-field

# HERSCHEL FM SPACECRAFT EMC TEST REQUIREMENT SPECIFICATION

REFERENCE : H-P-2-ASP-TS-0819

DATE : 10/08/2007

ISSUE : 3 PAGE : 71/80

---

RX :	Receiver
SAS :	Solar Array Simulator
S/C :	Spacecraft
SCC :	Sorption Cooler Compressor
SCE :	Sorption Cooler Electronics
SCOE :	Special Checkout Equipment
SCS :	Sorption Cooler Subsystem
SPIRE :	Spectral Photometer Imaging Receiver
SREM :	Standard Radiation Environment Monitor
STD :	Standard
STR :	Star Tracker
SVM :	Service Module
TBC :	To Be Confirmed
TBD :	To Be Defined
TC :	Telecommand
TM :	Telemetry
TRS :	Test Requirement Specification
TWTA :	Travelling Wave Tube Amplifier
TX :	Transmitter
UHF :	Ultra High Frequency
UUT :	Unit Under Test
VEB :	Vehicle Equipment Bay
WU :	Warm Unit
XPND :	RF Transponder

## ANNEX 1 : TEST AID DEFINITION

All the pin of the connectors test-aid shall be wired between the two connectors of the test-aid.

### Schematic for common mode and differential measurements :

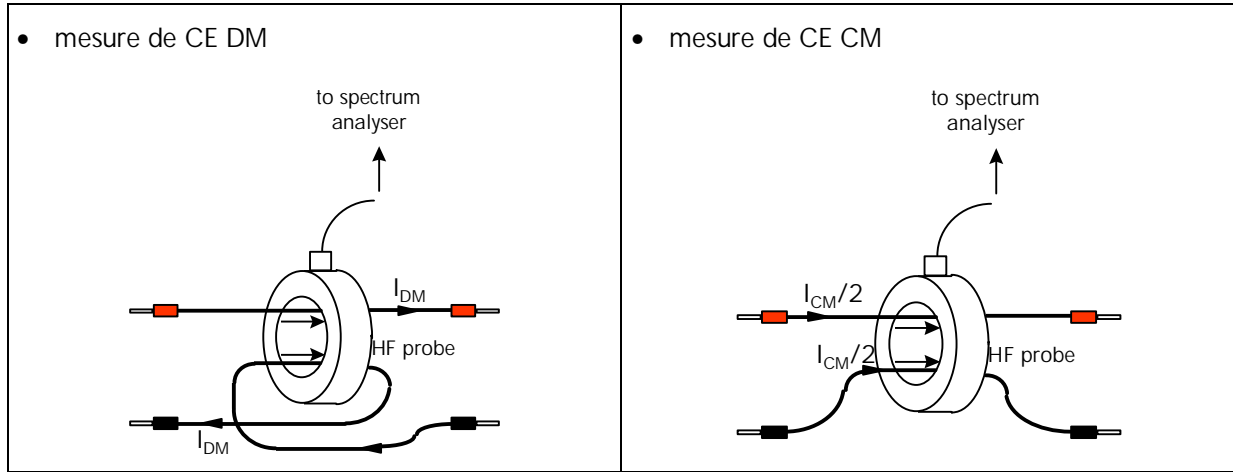

### Test-aid for TWTA :

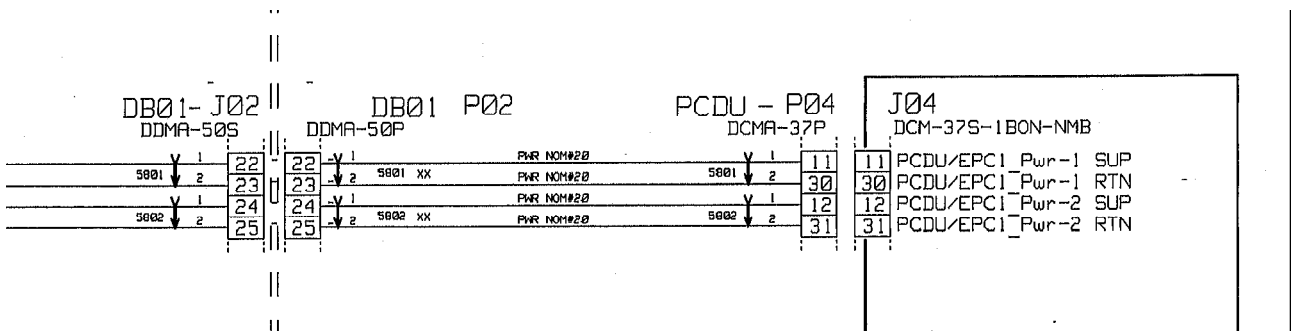

The test aid shall be placed at DB01 level, considering that the volume at PCDU level and connector density cannot allow us to put the test aid.

The measurement shall be done on the PCDU/EPC1\_Pwrs SUP/RTN

The test-aid shall be on harness side.



Test-aid for STR1:

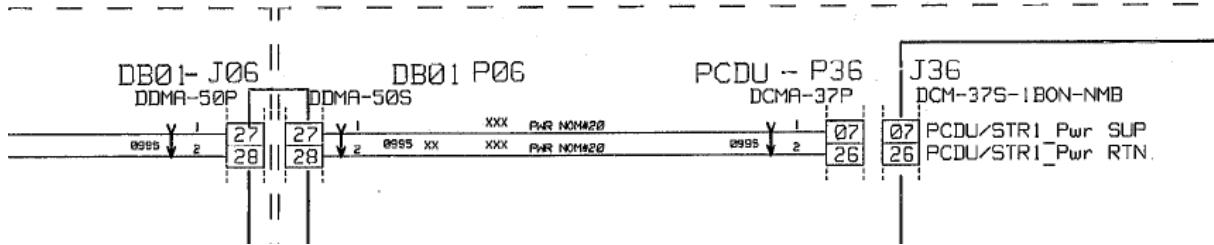

The test aid shall be placed at DB01 level, considering that the space at PCDU level and connector density cannot allow us to put the test aid.

The test-aid shall be on harness side.

Test-aid for ACC:

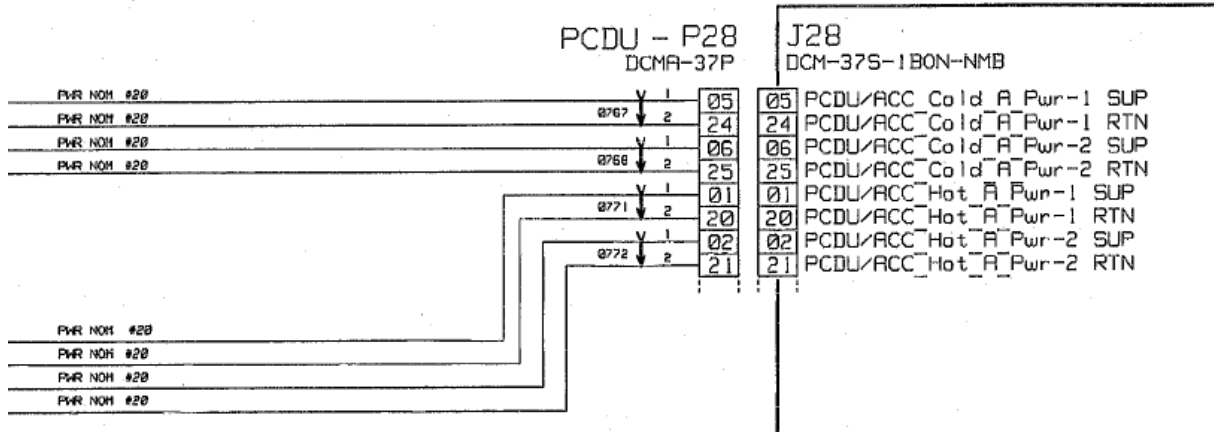

The test aid shall be placed at PCDU level.

The measurement shall be done on the PCDU/ACC\_Cold\_Nom\_Pwrs SUP/RTN.

# HERSCHEL FM SPACECRAFT EMC TEST REQUIREMENT SPECIFICATION

REFERENCE : H-P-2-ASP-TS-0819

DATE : 10/08/2007

ISSUE : 3

PAGE : 74/80

## Test-aid for CDMU:

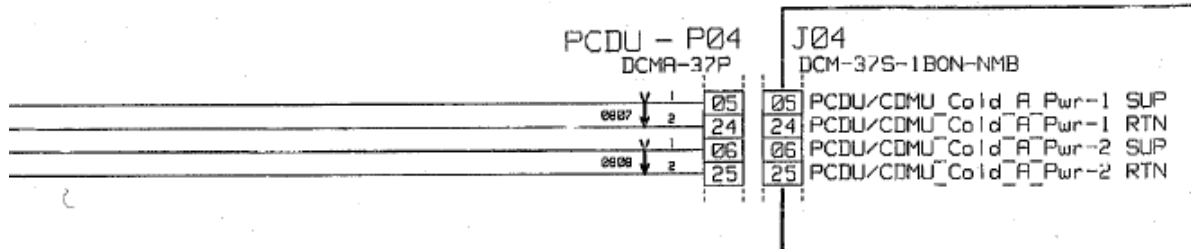

The test aid shall be placed at PCDU level.

The measurement shall be done on the PCDU/CDMU\_Cold\_Nom\_Pwrs SUP/RTN.

## Test-aid for DPU :

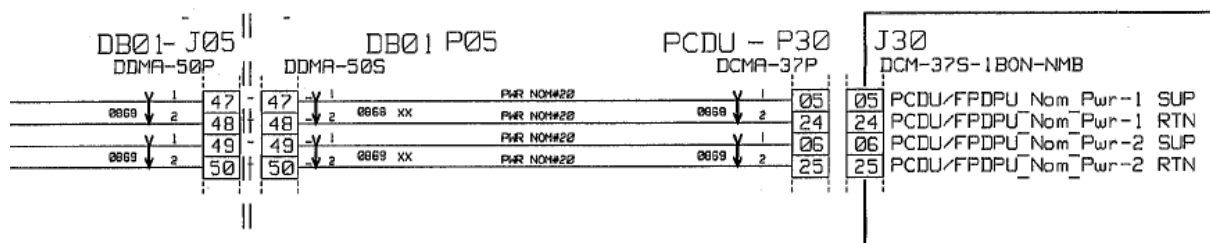

The test aid shall be placed at DB01 level, considering that the volume at PCDU level and connector density cannot allow us to put the test aid (TBC).

The measurement shall be done on the PCDU/FPDPU\_Nom\_Pwrs SUP/RTN

The test-aid shall be on harness side.

## Test-aid for SPU :

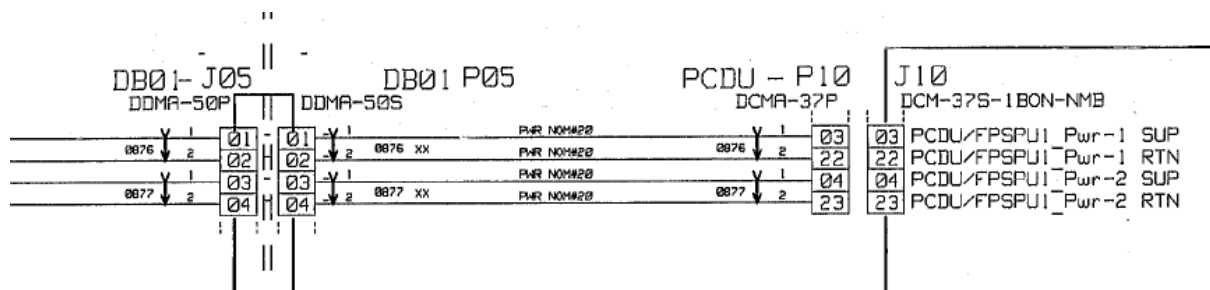

The test aid shall be placed at DB01 level, considering that the volume at PCDU level and connector density cannot allow us to put the test aid (TBC).

The measurement shall be done on the PCDU/FPSPU1\_Pwrs SUP/RTN

The test-aid shall be on harness side.

# HERSCHEL FM SPACECRAFT EMC TEST REQUIREMENT SPECIFICATION

REFERENCE : H-P-2-ASP-TS-0819

DATE : 10/08/2007

ISSUE : 3

PAGE : 75/80

## Test-aid for CCU :

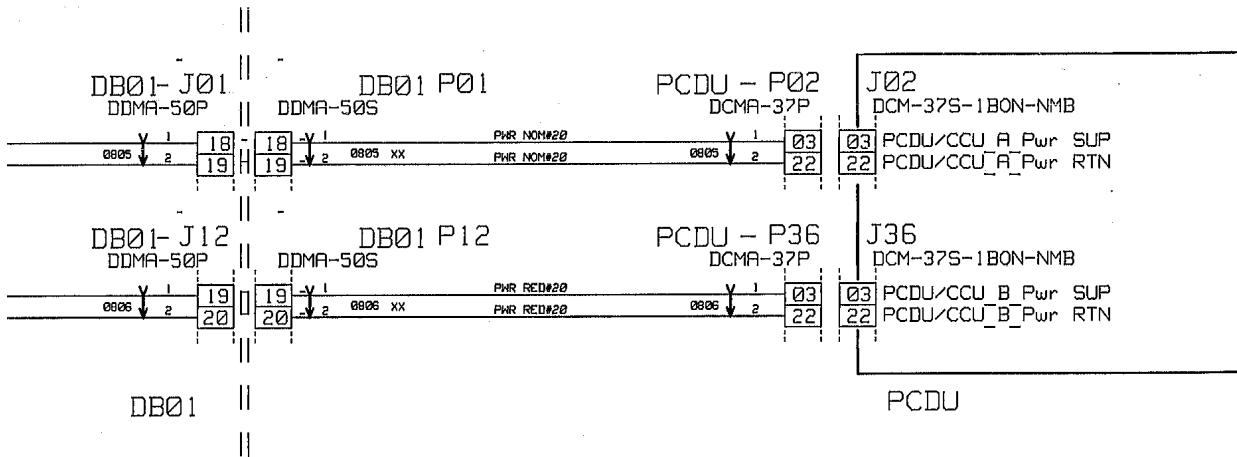

The test aid shall be placed at DB01 level, considering that the volume at PCDU level and connector density cannot allow us to put the test aid (TBC).

The measurement shall be done on the PCDU/CCU\_A\_Pwr SUP/RTN

The test-aid shall be on harness side.

## Test-aid for SPIRE/HSFCU :

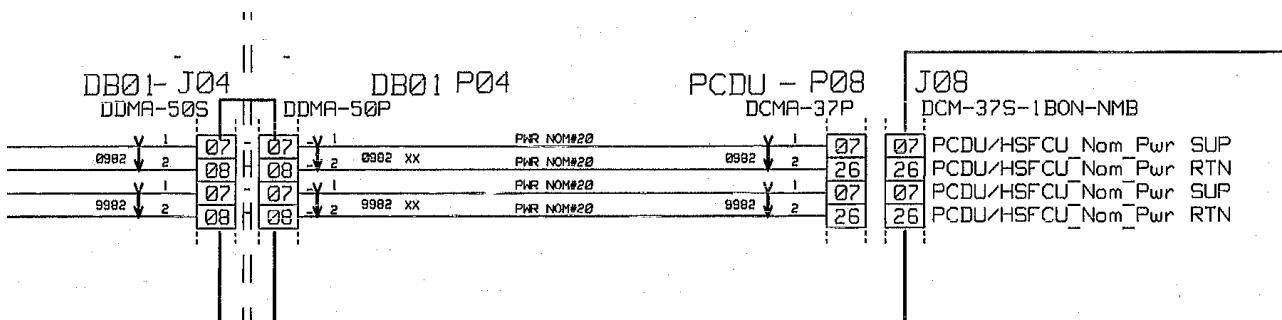

The test aid shall be placed at DB01 level, considering that the volume at PCDU level and connector density cannot allow us to put the test aid (TBC).

The measurement shall be done on the PCDU/HSFCU\_Nom\_Pwr SUP/RTN

The test-aid shall be on harness side.

# HERSCHEL FM SPACECRAFT EMC TEST REQUIREMENT SPECIFICATION

REFERENCE : H-P-2-ASP-TS-0819

DATE : 10/08/2007

ISSUE : 3

PAGE : 76/80

## Test-aid for HIFI/DPU-ICU:

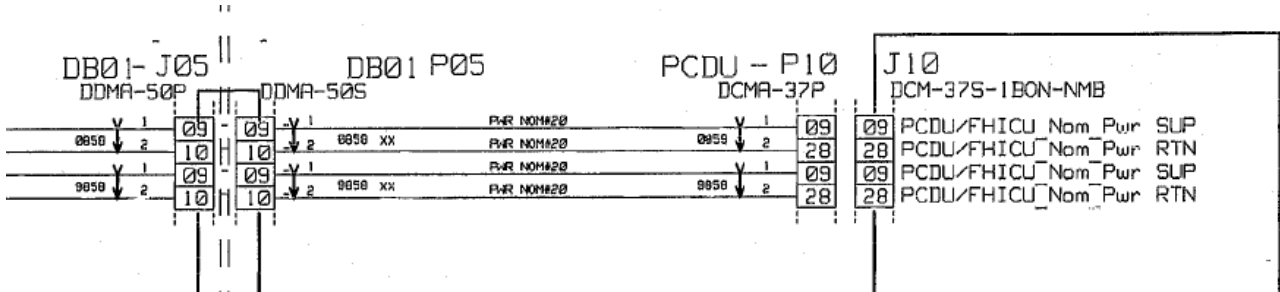

The test aid shall be placed at DB01 level, considering that the volume at PCDU level and connector density cannot allow us to put the test aid (TBC).

The measurement shall be done on the PCDU/FHICU\_Nom\_Pwrs SUP/RTN

The test-aid shall be on harness side.

## Test-aid for HIFI/LCU:

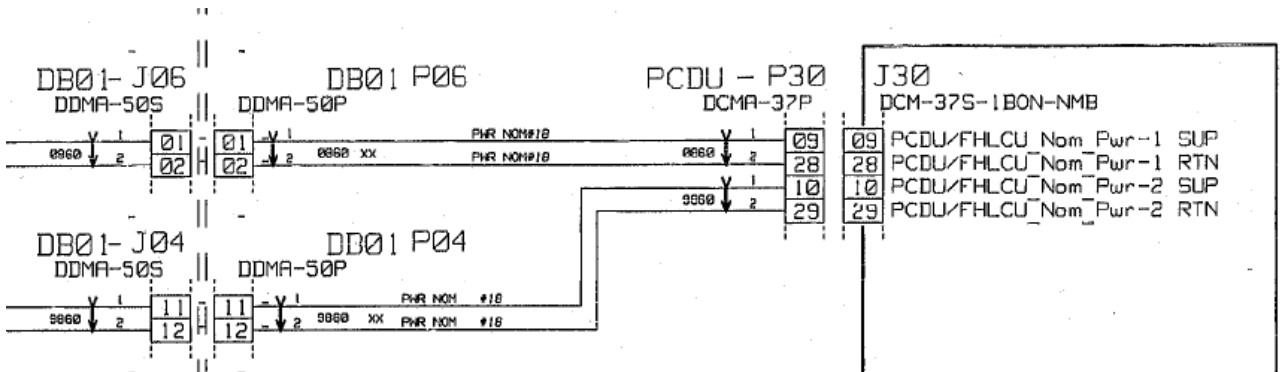

The test aid shall be placed at DB01 level, considering that the volume at PCDU level and connector density cannot allow us to put the test aid (TBC).

The measurement shall be done on the PCDU/FHLCU\_Nom\_Pwrs SUP/RTN

The test-aid shall be on harness side.

# HERSCHEL FM SPACECRAFT EMC TEST REQUIREMENT SPECIFICATION

REFERENCE : H-P-2-ASP-TS-0819

DATE : 10/08/2007

ISSUE : 3

PAGE : 77/80

## Test-aid for BOLC :

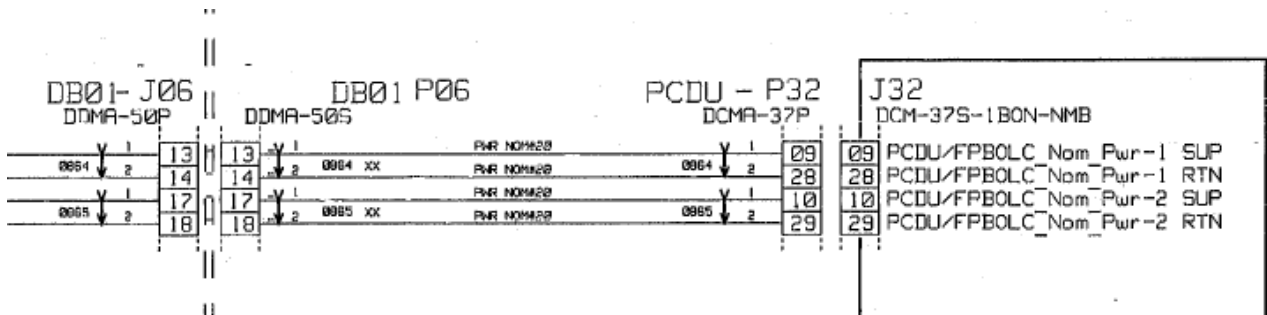

The test aid shall be placed at DB01 level, considering that the volume at PCDU level and connector density canno't allow us to put the test aid (TBC).

The measurement shall be done on the PCDU/FPBOLC\_Nom\_Pwrs SUP/RTN

The test-aid shall be on harness side.

## Test-aid for DECMEC :

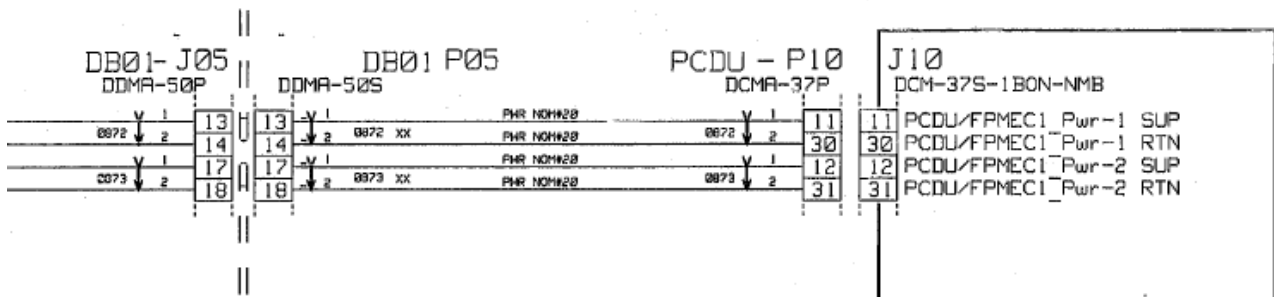

The test aid shall be placed at DB01 level, considering that the volume at PCDU level and connector density canno't allow us to put the test aid (TBC).

The measurement shall be done on the PCDU/FPMEC1\_Pwrs SUP/RTN

The test-aid shall be on harness side.

## ANNEX 2 : RWLS CS TESTS CONFIGURATIONS

### Test configuration for ToCo injection:

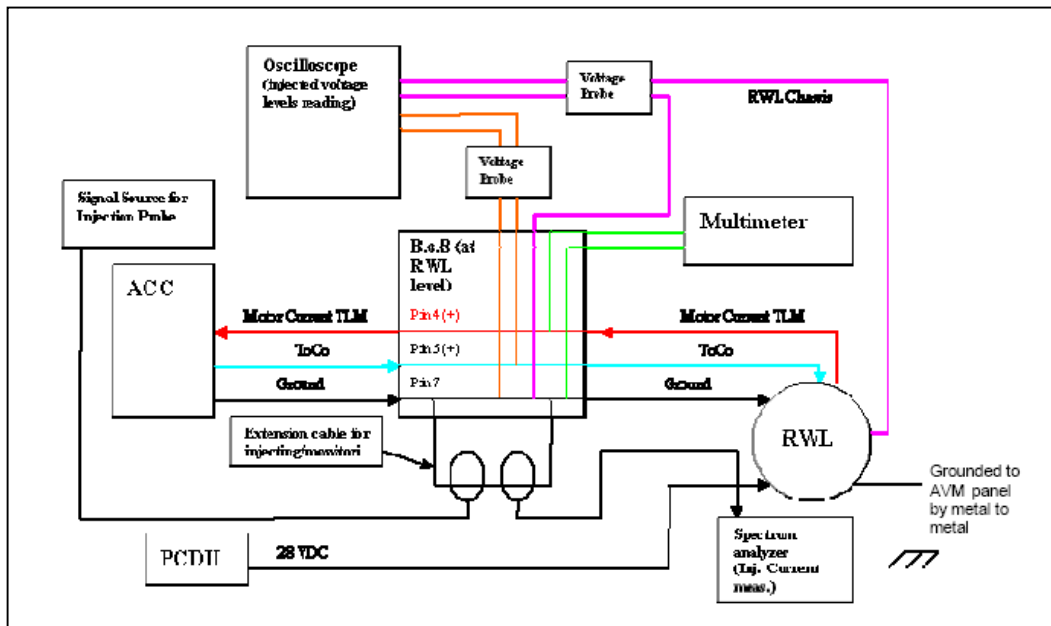

### Test configuration for TD injection:

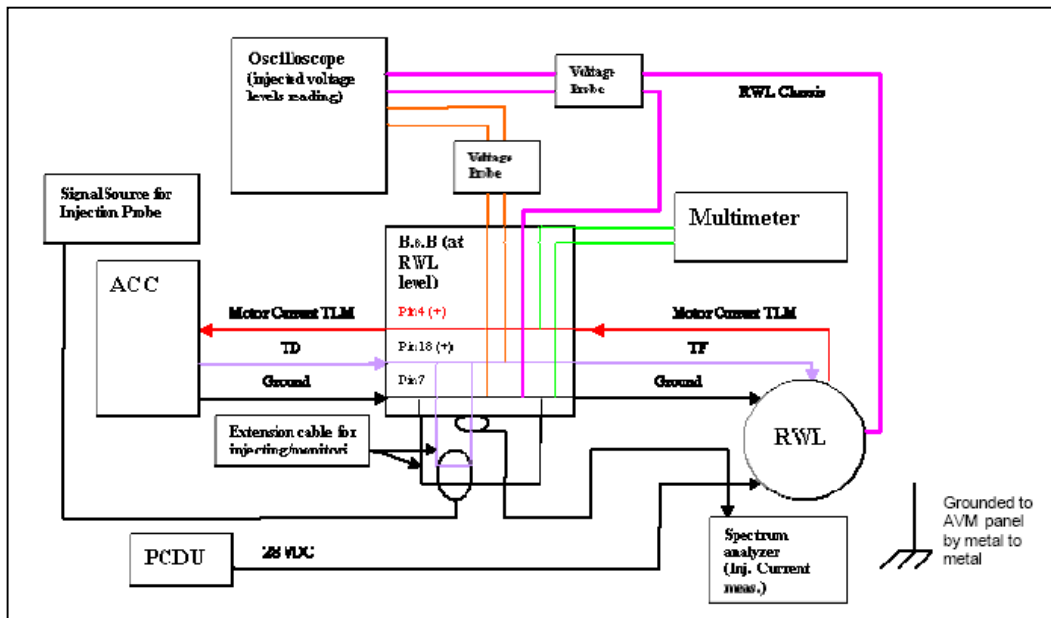

# HERSCHEL FM SPACECRAFT EMC TEST REQUIREMENT SPECIFICATION

REFERENCE : H-P-2-ASP-TS-0819

DATE : 10/08/2007

ISSUE : 3

PAGE : 79/80

## ANNEX 3 : RWLs IDS FOR ToCo AND TD MEASUREMENTS

CONNECTOR No.:		X2	CONNECTOR TYPE 15:		DEMA 25P NMB
PIN No.	Function	Type of line	Interface cabling requirement 16		Remarks
1	Housing	AWG 24			
2	Speed signal (tacho)	AWG 24	SH		
3	Shield 1 (tacho)				
4	Motorcurrent	AWG 24	TW with 5,6,7		
5	Torque command 1	AWG 24	TW with 4,6,7		
6	Torque command 2	AWG 24	TW with 4,5,7		
7	Analog ground	AWG 24	TW with 4,5,6		
8	NC				
9	NC				
10	NC				
11	ON command 1	AWG 24	TW with 12,13		
12	OFF command 1	AWG 24	TW with 11,13		
13	ON/OFF command return 1	AWG 24	TW with 11,12		
14	Temperature	AWG 24	TW with 15		Thermistor in the Ball Bearing Unit
15	Temperature return	AWG 24	TW with 14		
16	Status ON/OFF	AWG 24	TW with 17,18,19		
17	Speed direction	AWG 24	TW with 16,18,19		
18	Torque command direction	AWG 24	TW with 16,17,19		
19	Digital ground	AWG 24	TW with 16,17,18		
20	NC				
21	Test motorline	AWG 24			Not for S/C application
22	NC				
23	ON Command 2	AWG 24	TW with 24,25		
24	OFF command 2	AWG 24	TW with 23,25		
25	ON/OFF command return 2	AWG 24	TW with 23,24		

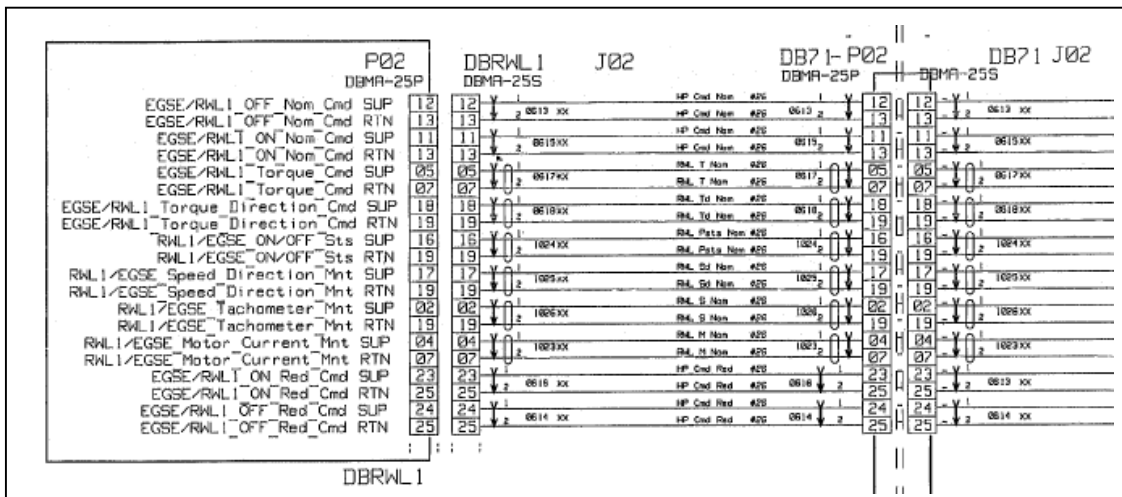

# HERSCHEL FM SPACECRAFT EMC TEST REQUIREMENT SPECIFICATION

REFERENCE : H-P-2-ASP-TS-0819

DATE : 10/08/2007

ISSUE : 3 PAGE : 80/80

---

End of Document