



# Technical Note

## SPIRE Alignment data summary

Ref: SPIRE-RAL-NOT-002876

Issue: 1.1

Date: 28/03/2007

Page: 1 of 5

### SPIRE Alignment data summary

Below are reproduced some data summary from the SPIRE AM, CQM, PFM and FS alignment verification test campaigns. The values are given in the Herschel ESA coordinates system ( $X_{ESA}$ ,  $Y_{ESA}$ ,  $Z_{ESA}$ ) as defined in the optical part of the ICD, reproduced below.

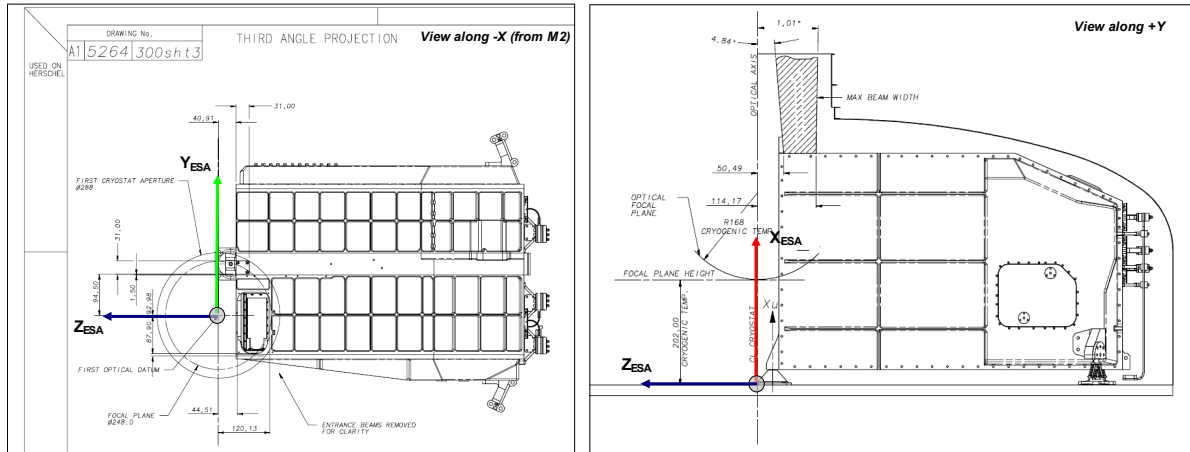

Figure 1: SPIRE optical interface drawings (from IID-B)

### 1. Pupil alignment data

A/ Ambient Pupil alignment (LOS of SPIRE Phot along gut ray from image focal plane to M2):

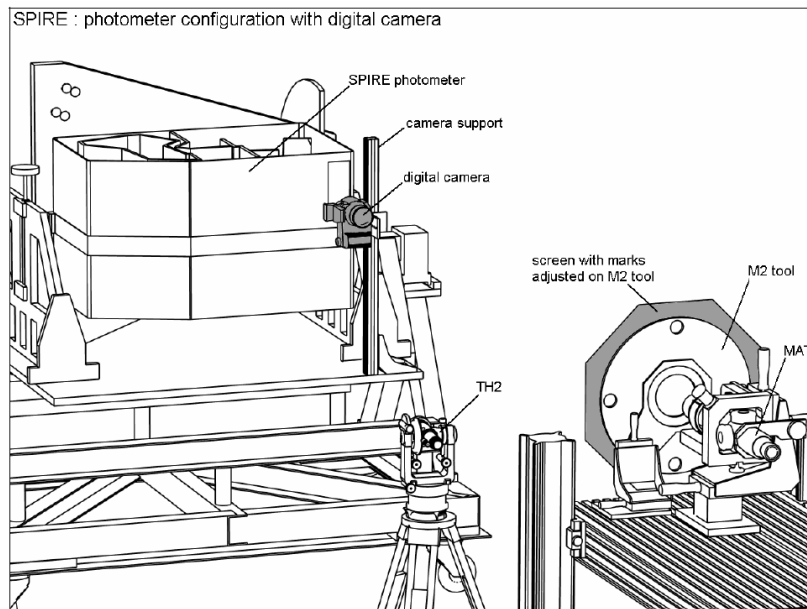

Figure 2: Set-up configuration for ambient pupil alignment verification on AM, CQM, PFM and FS (from RD1)

#### CQM:

- Shift in Y at M2 plane wrt M2 centre,  $\Delta Y = 6 \pm 0.5 \text{ mm}$
- Shift in Z at M2 plane wrt M2 centre,  $\Delta Z = 0 \pm 0.5 \text{ mm}$
- => radial pupil shift  $\Delta R/R = 3.9 \pm 0.3\%$  (with baseline reference M2 radius  $R_{M2} = 153.9 \text{ mm}$ )



## Technical Note

SPIRE Alignment data summary

Ref: SPIRE-RAL-NOT-002876

Issue: 1.1

Date: 28/03/2007

Page: 2 of 5

### PFM:

- Shift in Y at M2 plane wrt M2 centre:  $\Delta Y = -1.7 \pm 0.5 \text{ mm}$
- Shift in Z at M2 plane wrt M2 centre:  $\Delta Z = -0.7 \pm 0.5 \text{ mm}$
- => radial pupil shift  $\Delta R/R = 1.2 \pm 0.9\%$  (with baseline reference M2 radius  $R_{M2} = 153.9 \text{ mm}$ )

### FS:

- => radial pupil shift  $\Delta R/R = 6.5 \pm 1.6\%$  (with baseline reference M2 radius  $R_{M2} = 153.9 \text{ mm}$ )

**Source:** RD1, RD2, RD3, RD5 and RD6

### Remarks:

- This takes into account SPIRE internal (optics + structure) + FPU structure/HOB simulator i/f + HOB simulator/simulated M2 i/f;
- In the CQM case, this is also taking into account AM ambient measurement + CQM measurement on Phot side after replacement of CM3 and modifications of the Phot box.
- Data in all cases were obtained with SPIRE SOB perpendicular to gravity vector (g pointing towards +Y).

### B/ Cryo Pupil alignment (AM only)

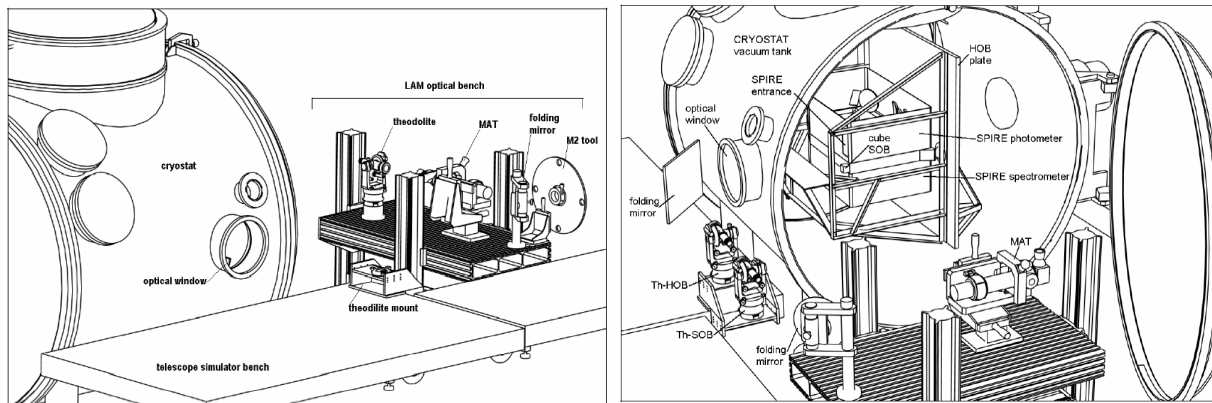

**Figure 3:** Set-up for the cryo alignment monitoring measurement (from RD1)

Rms variations on the above ambient values when SPIRE FPU cooled to 4K:

- Along Y: **0.8mm linear at M2 or 0.52% in equivalent pupil shift**
- Along Z: **0.2mm linear at M2 or 0.13% in equivalent pupil shift**

Uncertainty on these values:  $\pm 0.2 \text{ mm}$

=> **total ambient-to-cryo rms variations on pupil shift  $(\Delta R/R)_{\text{rms\_cryo}} = 0.54 \pm 0.18\%$**

**Source:** RD1, RD3 and RD4

### Remarks:

- The uncertainty is rms value derived from the angular monitoring (during thermal cycle) of the top surface of SPIRE cube wrt top surface of cube on HOB simulator i.e. structural only effect while the rms are the composite of environmental effects (pressure release + thermal cycle) on optical chain;
- The measurements were performed on the AM model with gravity vector point down along +Y in the measurement configuration.



## Technical Note

SPIRE Alignment data summary

Ref: SPIRE-RAL-NOT-002876

Issue: 1.1

Date: 28/03/2007

Page: 3 of 5

### 2. Axial and azimuthal alignment data

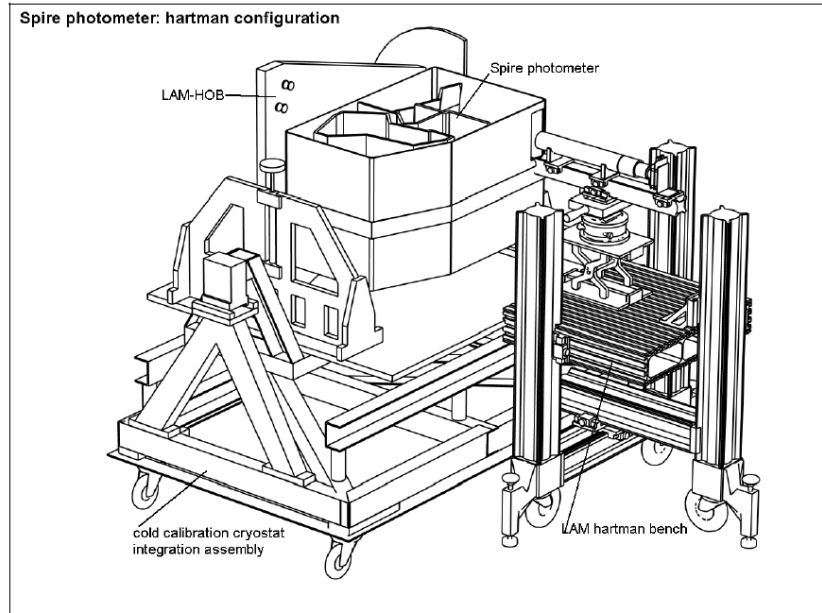

Figure 4: Set-up configuration for ambient image quality verification on AM and PFM (from RD1)

#### CQM:

- Ambient defocus measurement along X:  **$2.7 \pm 0.25 \text{mm}$**
- Rotation about X: **not measured/extracted**

#### PFM:

- Ambient defocus measurement along X:  **$< 2.0 \pm 0.25 \text{mm}$**
- Rotation about X:  **$< 0.25 \text{deg}$  (from pupil imagery)**

#### FS:

- Ambient defocus measurement along X:  **$< 3.0 \text{mm}$**
- Rotation about X:  **$< 1.2 \pm 0.4 \text{deg}$  (from pupil imagery)**

**Source:** RD1, RD2, RD3, RD5 and RD6

#### **Remarks:**

- This is given for centre of Phot field (gut ray) at Entrance Focal Plane i.e. worst-case from the measurement data;
- The value is derived from optical WFE measurement (Hartmann test) in the visible through the entire SPIRE Phot optical chain for the AM. The CQM is built with different (improved) CM3 mirror compared to AM so the actual value for the CQM is expected lower;
- This measurement does not take into account the interface Entrance Focal Plane/Cube but by design & fabrication of FPU Bench (=SOB) this can be estimated to  $\pm 0.2 \text{mm}$  max;
- No image quality test performed in the visible at cold temperature and due to long depth-of-focus in-band (especially because of PLW), the above value can not be detected/retrieved or confirmed by the CQM or PFM ILT performance test data (obtained at operating T).



## Technical Note

### SPIRE Alignment data summary

Ref: SPIRE-RAL-NOT-002876

Issue: 1.1

Date: 28/03/2007

Page: 4 of 5

### 3. Alignment reference (SPIRE cube) data

SPIRE optical reference (SOR) mounted on the external +X surface of the SOB.

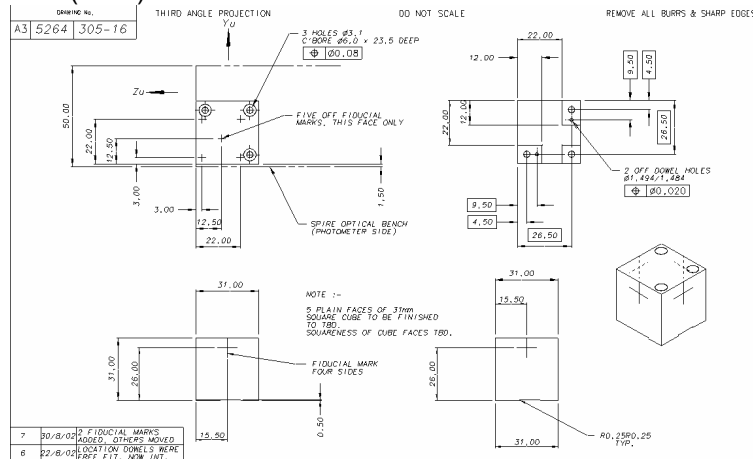

Figure 5: SPIRE cube (info from MSSL)

SPIRE Cube to be mounted on +X top surface of SOB.

- **Ambient static:**
  - Rotation about Y: **+7.3 ±0.5 arcmin**
  - Rotation about Z: **+3.7 ±0.5 arcmin**

- **Cryo (monitored thermal cycle performed on AM only, see Figure 3):**

Difference between ambient vacuum (293K) and cryo (10K) between SOR and fixed external reference

- Rotation about Y: **0.0 arcmin** (with 0.4 arcmin rms fluctuations during cool-down + warm-up)
- Rotation about Z: **0.4 arcmin** (with 0.3 arcmin rms fluctuations during cool-down + warm-up)

Difference between ambient vacuum (293K) and cryo (10K) between SOR and HOR (on HOB simulator)

- Rotation about Y: **0.8 arcmin**
- Rotation about Z: **0.5 arcmin**

Uncertainty on these values: **±0.125 arcmin about Z and ±0.3 arcmin about Y**

**Source:** RD1, RD3 and RD4

#### Remarks:

- Positive rotation angle is for trigonometric (anti-clockwise) orientation when looking along -Y (resp. -Z);
- Values were taken measurement on the +X surface of SOB wrt the i/f surface SPIRE/HOB simulator;
- The uncertainty value is derived from local flatness and cube squareness values, certified to be within the manufacturing specification;
- The reference i/f plate (HOB simulator) used here is not the same as the one used in section 1 above so care must be taken when using both set of data.

### 4. General remarks

Data above were extracted from measurements performed in the VNIR for higher accuracy but therefore obtained before the integration of the instrument optical filters & dichroics and bolometric detector arrays. Based on ambient and cryo metrology data at BDA level, interface plates between



## Technical Note

### SPIRE Alignment data summary

**Ref:** SPIRE-RAL-NOT-002876

**Issue:** 1.1

**Date:** 28/03/2007

**Page:** 5 of 5

main optics + structure (detector boxes) and BDAs were discussed and defined in SPIRE-RAL-NOT-002194 v0.3 (2004) and SPIRE-RAL-NOT-002344 v1.0 (2005), for PFM Spectrometer and Photometer sides respectively, in order to maintain, among other criteria, the above alignment results.

The last ILT performance test campaign including optical tests and performed after PFM last vibrations (i.e. PFM4) indicate during in-band co-alignment (i.e. end-to-end including optics) of central Spectrometer detector arrays to equivalent of  $1.5 \pm 1$  arcsec on-sky (i.e.  $\sim 0.2$  mm at Entrance focal plane) and  $\sim 2 \pm 1$  arcsec between PMW and PLW &  $\sim 4 \pm 2.5$  arcsec between PSW and PMW for the Photometer side.

Also a dummy GSE BSM (mirror+mount) was used during the main alignment verification tests. Differential comparative measurements were made with the flight BSM subsystem on the SOB and reported in SPIRE-RAL-NOT-002246 v1.0 (2004).

### References

**RD1** LAM.OPT.SPI.PRC-031203\_01 (2004)

**RD2** SPIRE-RAL-NOT-001807v2 (2004)

**RD3** SPIRE\_ColdAlignTest\_OpticalRefMonitoring.xls (2003)

**RD4** Optical alignment verification of the Herschel-SPIRE instrument, SPIE 5487(2004)

**RD5** SPIRE PFM AIT Logbook (2004)

**RD6** SPIRE-RAL-NOT-02944v1 (2007)