



# Herschel S/C IST specification

REFERENCE: H-P-2-ASP-SP-0939

DATE: December 20<sup>th</sup> 2007

ISSUE: 6.0

Page : 2

HERSCHEL/PLANCK		DISTRIBUTION RECORD	
DOCUMENT NUMBER : H-P-2-ASP-SP-0939		Issue 6 Rev. : 0 Date: December 20 <sup>th</sup> 2007	
EXTERNAL DISTRIBUTION		INTERNAL DISTRIBUTION	
ESA	X	HP team	X
ASTRIUM	X		
ALENIA	X		
		Documentation	Orig.

## ENREGISTREMENT DES EVOLUTIONS / CHANGE RECORDS

ISSUE	DATE	§ : DESCRIPTION DES EVOLUTIONS § : CHANGE RECORD	REDACTEUR AUTHOR
01	November 30 <sup>th</sup> 2005	First Issue.	P. COUZIN G. BEAUFILS
02	June 21 <sup>st</sup> 2006	<p>Chapters numbering is modified in order to match the AAS-F standard table of content for test specification. Besides chapter number and some addition described hereafter, the text and sequence of chapter is basically not affected. Note: no revision mark is provided for new chapter numbers.</p> <p>Chapter "6 Success criteria" is added to match the standard table of content for test specification. The information was previously given in first paragraphs of (now) §5. Some of the information has been kept in §5 as a duplicate to ease the comparison with issue 1.0. In chapter 6, revision marks are provided with respect to the Planck IST specification issue 1.0 which already includes this chapter. This allows to highlight only the deltas, as most readers know both documents.</p> <p>Chapter "7 Organisation and responsibilities" and "8 Documentation" are added and provide new information. Revision marks are provided with respect to the Planck IST specification issue 1.0 which already includes those chapters to highlight only the deltas.</p> <p>Throughout document , the obsolete IMT wording is replaced by SPT to designate the instrument performance validation test to be run before launch.</p> <p>§1.1.3 the present issue status is updated.</p> <p>§1.2.1 the wording is corrected to clarify that EMC and TVTB tests shall not be fully made out of IST sequences, and 1) that EMC test sequences will be typically adaptations of IST sequences, and 2) that for TVTB, the replay of some IST sequences will be an integral part of the test, but not all of it.</p> <p>§2.1 H-P-2-ASP-TS-1083 has been created to provide the details of the instrument test sequences, and is added to the applicable document list. §3.1.1 and §3.2.1 are updated to reflect those document inputs (specifically where it replaces RD07).</p> <p>§2.1 the issues of the applicable documents are added, to provide unambiguous references, even if latest issues shall be applicable.</p> <p>§2.2 the issues of the reference document are updated, made complete and/or detailed (SVM-UM) including amendments where applicable.</p> <p>§2.2 RD24, RD25, RD27, RD30, RD31, RD32 and RD33 are added.</p> <p>§3.1.1 is corrected and complemented, that the solar array is not used (SAS connected in its position), then it is not necessary mounted when IST is run.</p> <p>§3.1.1 the baseline for satellite tilt management is defined.</p> <p>§3.1.2 it is made more clear that instrument IEGSE are part of the global GSE configuration.</p> <p>§3.1.2 it is added that all TC send by ground (CCS) shall be up-linked with</p>	P. COUZIN G. BEAUFILS

	<p>a low priority setting unless explicitly specified for.</p> <p>§3.1.3 it is pointed out the fact that RD12 is obsolete with respect to instrument AVM configuration, and that a better reference for this point is to be found in IID-B. It is added also that a dedicated instrument AVM upgrade is at work for PACS and SPIRE, then that the AVM references are living. It is clarified also that the main limitation of the AVM is that "all B units" configuration (as defined by §5.2) cannot be tested, and so that, on AVM all tests will be run in "all A units" configuration.</p> <p>§5.6 regroups in a single paragraph, the older §7.6 and 7.7 content.</p> <p>§5.7 is created to regroup technical requirements that are applicable to all the sequences.</p> <p>§7.5.1 is created to gather general SSMM management requirements.</p> <p>§5.7.2 is created to gather general DTCP management requirements.</p> <p>§5.7.3 is created to gather the general cryostat management requirements. §5.8.2.3 is updated in coherence.</p> <p>§5.8 the S/C state summary tables presentation is upgraded. The CRS status field is moved in the ACMS box. The OBT PM and SW fields in CDMS box are grouped in the same cell to allow a SCBP field to be added. Appendix 2 is updated accordingly.</p> <p>§5.8 the general correction is made, that the S/C configuration for cruise to L2, when S/C is not in communication session, is NOM mode, with TWTA OFF and ACMS in SCM Earth pointed.</p> <p>§5.8 the general correction is made, that antenna configuration in SAM mode shall be LGA1 on main XPND and MGA (not LGA2) on redundant XPND (except for the specific case of a transition from launch mode).</p> <p>§5.8 all the mode transition success criteria and procedures (TC sets) are corrected after SRD amendment 2 and 3.</p> <p>§5.8.2.3 the specific test configuration necessary for allowing the cryostat valves V501 and V503 operation is presented. The related operation warning and details are added §5.8.4.2.1 §5.8.4.2.5 and §5.8.4.2.8.</p> <p>§5.8.2.3 the detail requirements upon the cryo-cover NCA monitoring are transferred to the §5.8.3.12 (this text was an artefact of draft 4 when cryo-cover test was appended to the launch sequence and not as presently, to the commissioning one). Simplified requirements are kept nevertheless in §5.8.2.3 to keep an observability over any spurious activation during the launch sequence.</p> <p>§5.8.2.4.1 a warning is added to recall the specific precautions and GSE connections that are necessary to allow without risk, the actual command of the cryostat valves.</p> <p>§5.8.2.4.2 and §5.8.2.4.8 it is added that the CCU shall be activated with a 8s sampling interval for launch, and sets to default 512s sampling interval afterward. This specific CCU state is recalled in the S/C state summary tables in chapter §5.8.2.4.2 to §5.8.2.4.7 with a corresponding legend in appendix 2.</p> <p>§5.8.2.4.2 is added the need of synchronising the ACC time on CDMU one as part of the satellite power on procedure. In §5.8.4.2, is added the explicit test of the automatic instrument clock synchronisation on 1553 time broadcast, as well as a fine synchronisation verification procedure (TC(9,5)) exercise in both instrument boot SW and ASW running cases.</p>	
--	---	--

	<p>§5.8.2.4.2 the observation criteria upon HPS and ES are upgraded, to reflect specifically that the automatic switch OFF of unused HPS at TCS SW service initialisation is suppressed in the latest CDMU ASW versions.</p> <p>§5.8.2.4.4 to .7 several points are corrected that were incoherent with new TTC baseline for launch : with TWTA being OFF until separation, and a later satellite acquisition by the ground. This includes a new variant for Tx chain in the S/C state tables, which is detailed in appendix 2.</p> <p>§5.8.2.4.5 and §5.8.2.4.6 the success criteria associated with the cryostat valve actuation by CCU after ARIANE 5 dry loop signal is added.</p> <p>§5.8.3.8 it is added that the CCU / cryostat commissioning test shall include a DLCM test.</p> <p>§5.8.3.10 are added the references to SREM test specification (RD27) chapters which are applicable for its commissioning test.</p> <p>§5.8.2.4.9 the EMC sequence is suppressed. A specific specification has been created.</p> <p>§5.8.4.3 it is added that an ENV simulator open loop operation may be studied to save configuration time when the instrument needs no ACMS simulated actions during test.</p> <p>§5.8.4.5 is added, the SPIRE commissioning test programme.</p> <p>§5.8.4.6 is added, the HIFI commissioning test programme.</p> <p>§5.8.4.7 is added, the PACS commissioning test programme.</p> <p>§5.8.4.7 is added, the PARALLEL mode commissioning test programme</p> <p>§5.8.5.2 is added a diagram that recalls the detailed mode and state transition chaining throughout the test sequence.</p> <p>§5.8.6 the approach to stimulate a level 3 transition is modified in favour of the use of the ASW dedicated "software alarm" forcing commands (formerly were considered spurious reset or spurious SIR/CIR/AIR setting).</p> <p>§5.8.6.1 and 5.9.3.2 a reminder is added to recall that after each sequence involving an autonomous transition, the RM registers and log shall be reset in a proper configuration before chaining an another sequence.</p> <p>§5.8.6.2 is added a diagram that recalls the detailed mode and state transition chaining throughout the test sequence.</p> <p>§5.8.7.2 is added a sample test of MOT and EAT operation, based on the correct detection of a spurious RF switch toggle (MOT) and SPIRE TM(5,2,0xC100) and TM(5,2,0xC110) interception (ETA).</p> <p>§5.8.7.2 is added at the end of the test, an on board time update test (both forward and backward). Note : it is expected to create temporary SW anomalies at CDMS, ACMS and instrument level.</p> <p>§5.8.8.2 is added as part of the DTCP worst case scenario, a SSMM download abort then resuming exercise.</p> <p>§5.8.8.2 is added as part of the DTCP worst case scenario, the a test of the ability to upload a full new SW image to one instrument (1Mo)</p> <p>§5.8.9.3 the new RMS sequence design is presented. §5.8.9.4 to §5.8.9.6 instrument activity are presented (completed for PACS, partial for SPIRE, TBC for HIFI).</p>	
--	--	--

		<p>§5.9.2.2 and §5.9.3.2 diagrams are added to display the expected mode transition sequences.</p> <p>§6.2 is added a clarification upon the generic wording "out of limit" and what it addresses in term of CCS automated checking mechanism.</p> <p>Appendix 1, is updated, requirements are sorted by document, requirement tables and figures are inserted.</p> <p>Appendix 2, SCOE setting field description added.</p> <p>Appendix 3, applicable (available) flight operation procedure extracted from RD18 vol. 8 are listed for easier cross references.</p> <p>Appendix 6, obsolete LCL line power and current information is removed.</p> <p>Appendix 8 is added to recall some useful basic information upon CMDS and ACMS operating modes.</p> <p>Appendix 9 is added to provide a table that recall the alarm case tested at both S/C IST (present) and SVM IST.</p> <p>Note: to ease readability, the replaced text has been usually suppressed. Deleted text (no replacement) has been left to mark the modification position, but may have been compacted.</p>	
03	September 29 <sup>th</sup> 2006	<p>§1.1.2 Definitions are updated to take into account the program evolution (this includes AI#21 of H-P-ASP-MN-8177).</p> <p>§1.1.2 and 1.2.1 The reference to IST on launch site is suppressed as a specific requirement specification will be issued (update).</p> <p>§1.1.3 Present issue status is updated.</p> <p>§1.2.2 Typing in Herschel name is corrected (AI#5 of H-P-ASP-MN-8177).</p> <p>§2.1 and §11.1 ADO4 reference number correction (AI#11 of H-P-ASP-MN-8177) ADO6 title and reference update</p> <p>§2.2 RD35 "H/P IST Thermal prediction" added.</p> <p>§3.1.1 Wording "any" corrected in "all" (AI#25 of H-P-ASP-MN-8177).</p> <p>§3.1.3 Text updated, wording clarified, and reference to appendix 10 (§18) added (internal AAS-F comment).</p> <p>§3.1.2 EGSE architecture diagram added (AI#35 of H-P-ASP-MN-8176) RD35 reference added for cooling fan need (was TBC-29)</p> <p>§3.2.1 technical constraints coming with SPT are made more explicit with rewording agreed in H-P-ASP-MN-8177 (AI#26).</p> <p>§3.2.2 §3.2.3 Reference made to §7.1.1, §8.3.2.2 and ADO6 for details.</p> <p>§5 and §10 Useless "WD enable" field in state tables (always ON) is replaced by an FDIR field recalling the AFS/AFO configuration of the CDMS (old project). The information upon the ACMS AFO/AFS state is added in the previous ARAD field. The information upon the state of the MTL is added in the previous SCBP field. The information upon the survival CBH is added also in the new CDMS FDIR field.</p>	P. COUZIN G. BEAUFILS



	<p>§5.1.2 and 5.2 Software image 1 usage made explicit for relevant test days in timeline table, and legend complemented in §5.2 (to answer a recurrent question). Schedule modified for SPIRE spectrometer commissioning, to cope with the 24h autonomy limitation of the cryostat in horizontal position (RMS not possible in horizontal position).</p> <p>§5.8.2.3 "Rx Ant" and "Battery" pre-existing state clarified in state table. Practical limitation with POWER SCOE LPS usage and turn around explained. LPS is used only for "launch clean run" sequence (Planck test preparation feed back).</p> <p>§5.8.2.3 Cryo SCOE name corrected in CVSE wrt N511, N512, N513 pumping task (AI#8 of H-P-ASP-MN-8177).</p> <p>§5.8.2.3 V103 and V106 closing to be done by TC through CCU-A, not CRYOSCOE (after AI#9 of H-P-MN-8177).</p> <p>§5.8.2.4.2 to §5.8.2.4.4 Satellite configuration is done with telemetry set to LOW2 (5kbps) only (AI#25 of H-P-ASP-MN-8176).</p> <p>§5.8.2.4.2 Wording about CCU commanding is corrected (AI#8 of H-P-ASP-MN-8177).</p> <p>§5.8.2.4.2 ACC set-up operation re-ordered. "test data word bit 8" setting specifically made explicit (this is a delta for launch clean run case) (Planck test preparation feed back).</p> <p>§5.8.2.4.2 and §5.8.2.4.4 The CRS turn ON is moved before ACC turn ON, to secure the CRS against any fault in the ACMS SCOE set-up sequence (CRS may be degraded if stimulation is activated while the unit is still OFF) (Planck test preparation feed back).</p> <p>§5.8.2.4.3 DELETED (no unit health check or other test done under fairing before launch (was TBC-8)).</p> <p>§5.8.2.4.5 Wording "do confirm" and dry loop names corrected (AI#8 of H-P-ASP-MN-8177). A TBC is added about dry loop signal timing to establish a link with future feed back from STM2 test results.</p> <p>§5.8.2.4.5 to §5.8.2.4.8 A statement is added to points out the need for the availability of an emergency procedure to close V501 and V503 at cryostat responsible request (AI#10 of H-P-ASP-MN-8177).</p> <p>§5.8.2.4.6 to §5.8.2.4.10 missing autonomous SCBP switching at separation corrected (from check of ASW SRD amendment 2 issue 7).</p> <p>§5.8.2.4.7 A statement allowing for an emergency closing of V501 and V503 at cryostat specialist request is added (AI#10 of H-P-ASP-MN-8177).</p> <p>§5.8.3.3 Decontamination point is updated to latest hypothesis (AI#9 &amp; 10 of H-P-ASP-MN-8177 as overwritten by later elements).</p> <p>§5.8.3.11 conflicting / interfering between decontamination and CDMS / PCS commissioning made explicit (resource sharing) (AI#32 of H-P-ASP-MN-8176).</p> <p>Decontamination settings (TBC-16 / TBW-14) are now defined (AI#9 &amp; 10 of H-P-ASP-MN-8177 as overwritten by later elements).</p> <p>§5.8.4.9 The science TM shall be also downloaded from SSMM for verification with real time TM (not only Hk) (AI#1 of H-P-ASP-MN-8177).</p> <p>§5.8.5.2 to §5.8.5.19 Mode transition diagrams corrected and upgraded with extra info. as MTL and Reaction Wheel usage activation marker. Some ACMS mode and GSE states are also corrected in some satellite state tables</p>	
--	---	--

	(correction indications from different sources)	
	§5.8.5.5 Typing corrected : "force separation" TC shall be exercised in this sequence, not the nominal strap opening (feed back from Planck test preparation).	
	§5.8.5.6 Separation strap opening added to restore correct configuration after §5.8.5.5 update.	
	§5.8.6.7 SAS setting methodology clarified (feed back from Planck test preparation).	
	§5.8.7.1 Objective list is updated to reflect all the activities finally agreed to be part of this sequence (AI#1 of H-P-ASP-MN-8176).	
	§5.8.7.2 Subparagraph are created to ease test objective discrimination. The TC to command CDMS OBT update is corrected (shall be TC(9,10)).	
	§5.8.8.2 An EEPROM patch test limited to one or two word is added for each instrument (point 5 of activities, AI#29 of H-P-ASP-MN-8176). The 1Mo instrument software image upload test (point 4) is detailed according terms agreed in H-P-ASP-MN-8176.	
	§5.8.9.3 Added a diagram and a reference to H-P-ASP-MN-8338 which agree on the RMS scenario. Previous proposal for a dummy pointing cycle (appendix 5) is kept as a back-up solution.	
	§5.9.2.2 Mode transition diagrams upgraded with extra info. and corrected with respect to ACMS RM behaviour (no launch specific PAP) (feed back from test preparation).	
	§5.9.3.2 1553 bus failure simulation procedures improved by considering CDMU SCOE use (feed back from AAS-I CDMS SIT).	
	§5.8.10.2 SAS and AAD optical stimulation criteria made explicit. LPS "test data word bit 8" specific settings added, in relation with §5.8.2.3 and 5.8.2.4.2 modifications (feed back from Planck test preparation).	
	§6.3.1 The different kinds of TC check and monitoring done as routine verification following the HPSDB settings are detailed (AI#5 of H-P-ASP-MN-8176).	
	§6.3.2 Title and introducing paragraph modified to fit with additions made in §6.3.1	
	§7.1 "Organisation" completed (was TBW).	
	§7.1.2 added to detail organisation with respect to the instrument team (include AI#2 of H-P-ASP-MN-8177).	
	§7.1.3 added to detail accommodation conditions for ESA observers (AI#31 of H-P-ASP-MN-8176).	
	§7.2 "Responsibilities" completed (was TBW).	
	§7.3 "Task distribution" completed (was TBW).	
	"heritage" wording replaced by "derived" for procedure preparation (ASED insisting demand)	
	§8.2 Systematic plot of cryostat data added (AI#13 of H-P-ASP-MN-8177).	
	§ 9 Reference to accepted RFD and RFW added when applicable (ESA accepted RFD and RFW only).	
	§10.15 a typing in "T.2 A.A" ref. is corrected (AI#8 of H-P-ASP-MN-8176).	



# Herschel S/C IST specification

REFERENCE: H-P-2-ASP-SP-0939

DATE: December 20<sup>th</sup> 2007

ISSUE: 6.0

Page : 9

		<p>§14 TBC, TBD, TBW list updated in coherence with modifications.</p> <p>§15 TBC14, TBW13 and TBW14 responsibility corrected from ASED to AAS-F (AI#12 of H-P-ASP-MN-8177).</p> <p>§18 AVM S/C IST applicability matrix added, with test restrictions as applicable to each sequence (AI#19 of H-P-ASP-MN-8176).</p> <p>§19 Clarification and recall tables added with respect to EGSE and S/C boot configuration (feed back from Planck test preparation).</p>	
4.0	July 30 <sup>th</sup> 2007	<p>§5.9.2.2 Error in diagram corrected (after ACMS 3a alarm, mode is still SBM).</p> <p>§1.1.1 §1.1.2 Some statements are removed / made more general to prevent unnecessary contradiction with possible future project evolution.</p> <p>§1.1.3 "Present issue status" is customised to issue 4.0 case.</p> <p>§1.2.1 Some statements are removed / made more general to prevent unnecessary contradiction with possible future project evolution.</p> <p>§1.2.1 In the "important notes" point: the position of present document as a "high level specification" is clarified.</p> <p>§2.1 §2.2 S/C, SVM, INST, and units User Manual are made explicitly applicable, either by adding them or by moving them from the "reference document" section.</p> <p>§2.1 §2.2 Document reference issues are updated when available.</p> <p>§3.1.3 The "AVM case" is enlarged into a more generic "S/C debug case" to cope with the more numerous test configurations</p> <p>§5.1 Title reworded to better fit with new contain</p> <p>§5.1.1 Updated to take into account the clean up in the "degraded case" section (see 5.8.11 and 5.8.12)</p> <p>§5.1.2 Update to keep coherence with the other parts of the document (test sequence numbering), to include the cryostat state requirement and the experience return upon test sequence duration.</p> <p>§5.2 §5.3 §5.4 Moved under §5.1.3 §5.1.4 §5.15 to highlight the introduction character of those paragraphs.</p> <p>§5.8.7.2.5 A test of a PCDU I/F failure is added to the FDIR level 1 and 2 test cases considered, after ESA request as per action 6 of H-P-ASP-MN-8591. SPIRE case is moved to new §5.8.13.</p> <p>§5.8.11 §5.8.12 The paragraph §5.9.2 Launch mode robustness and §5.9.3 NOM mode robustness, are moved in the "Nominal cases" sections. They were in the "degraded case section" in early specification issues to highlight that they were to be run only once (i.e. not repeated in IST2). This has been amended since then (IST1 and IST2 shall be identical), but chapter numbering was kept, creating some confusion that chapter displacement shall solve.</p> <p>§5.8.11 Separation strap 3 &amp; 5 failure is inverted, as double failure between strap 3 early opening and ACMS PM-A failure was leading to an impossible ACMS SW branching. With inverted order, double failure is properly managed (combining several robustness tests in a single sequence).</p>	P. COUZIN G. BEAUFILS

# Herschel S/C IST specification

REFERENCE: H-P-2-ASP-SP-0939

DATE: December 20<sup>th</sup> 2007

ISSUE: 6.0

Page : 10

		<p>§5.8.13 A new sequence is added in answer to ESA request as per action 1 of H-P-ASP-MN-8591, to implement a systematic testing of all OBCP in an end to end context (considering nevertheless only one of the trigger source). Note: in issue 3, only a sample test was done in frame of §5.8.7.2.5 (removed)</p> <p>§5.9.2 §5.9.3 Moved to §5.8.11 and 5.8.12 see those § change notice for rational.</p> <p>All the other modifications are linked to S/C IST test sequences development feed back, better S/C operation understanding and ACMS/CDMS software evolutions.</p> <p>Thanks to the Herschel and Planck AIT engineering teams for their support.</p>	
5.0	November 30 <sup>th</sup> 2007	<p>Update after ESA comments as agreed per H-P-TASF-MN-9704</p> <p>§2.1 DZ-01 : typings in ACMS FCP/CRP document. ref. corrected          §2.1 DZ-29 : H-P-1-ASP-TN-1383 added as AD39          §2.1 JW-45 : AD17 reference updated</p> <p>§2.2 CS-01 : RD08 reference updated          §2.2 JP-01 : RD38 added to trace input for §5.8.2.4.10 modification</p> <p>§3.1.1 FP-02 : reference to horizontal position, after decision of removing SPIRE spectrometer testing from S/C IST scope (i.e. cryostat cannot operate in the horizontal position as suitable for SPIRE spectrometer test).</p> <p>§3.2.1 CS-02 : horizontal position reference deleted and need to keep SMEC locked, after removing SPIRE spectrometer testing from S/C IST scope.</p> <p>§5.1.1 DZ-03 JP-01 : typing in paragraph 5.9.2 corrected</p> <p>§5.1.2 AG-07 : Test reference timeline updated to reflect the removal of SPIRE spectrometer testing from S/C IST scope.</p> <p>§5.5 JW-03 : "power on reset" note reworded for clarity (S/C ON)</p> <p>§5.6.1 JW-04 : figure reformatted</p> <p>§5.7.4.1 CS-03 AG-08 : Table updated</p> <p>§5.7.5 DZ-31 : requirement added upon systematic checking of ACMS mode telemetry toggling (autonomous for non essential TM and ground commanded ones for essential TM)</p> <p>§5.8.2.4.4.6 BJ-01 + NCR-3472 experience return : a check and confirmation of the BDR, BCR and DNEL state is added.</p> <p>§5.8.2.4.6 DZ-15 JW-07 : ACMS rate anomaly tempo corrected</p> <p>§5.8.2.4.10 : ST-01 Delta V manoeuvre is made representative of the actual flight planned manoeuvre          §5.8.2.4.10 DZ-23 : AD32 replaces RD03 reference          §5.8.2.4.10 DZ-24 : OCM sub-state corrected</p> <p>§5.8.4.3 JW-10 : added a recall upon OBCP activation for this test</p> <p>§5.8.4.9 ST-03: reference added to ADO6 for success criteria on the instrument side.</p> <p>§5.8.5.5.1 ...5.1 ...5.2 DZ-37 : 2<sup>nd</sup> STR commanding and LCL state</p>	P. COUZIN G. BEAUFILS

	<p>§5.8.5.17.1 JW-20 JW-21 FDB-05 : preparatory transition reworded for clarity after deletion of 5.8.5.15 and ...16 § in issue 4.</p> <p>§5.8.6.5.1 JW-27 table headline reworded</p> <p>§5.8.8.2.1 JW-37 : "" added to table entries that shall be indeed changing during the sequence</p> <p>§5.8.8.2.2 JW-35 JW-36: typing in "chunk" and "1Mbyte" corrected</p> <p>§5.8.9.6 ST-03: reference added to ADO6 for success criteria on the instrument side.</p> <p>§5.8.10.2 FDB-01 : §5.8.2 reference corrected</p> <p>§5.8.10.2 JW-39 : paragraph about 150/500bps transition reworded</p> <p>§5.8.10.3 DZ-15 JW-07 : ACMS rate anomaly tempo corrected</p> <p>§5.8.13.3 JW-41 JW-42 : text with missing words reworded</p> <p>§5.8.13.4 to .6 JW-44 JW-45 JW-46 JW47 JW-48 CS-06 : cut and paste corrected in OBCP names, texts and § titles. OBCP tables updated with respect to AD19 issue 2</p> <p>§5.8.13.7 JW-49 : recall that TM (1,2) (1,8) (5,2) and (5,4) may nominal occurs as part of the test, and are not NOGO.</p> <p>§9.5 §9.6 CS-07 CS-08 : update of HIFI and PACS power requirement after RFW</p> <p>§5.9.2 LS-05 Instrument N&amp;R configuration tested so that all the 1553 BC (CDMS side) bus, and RT (instrument side) cross straps are verified</p> <p>§10.5 JW-14 : MTL state table indication descriptions updated (update forgotten in issue 4)</p> <p>§18 19 20 FDB-03 : appendix numbering corrected</p> <hr/> <p>Corrections after test experience return and new inputs</p> <p>§2.2 link budget report added as a RD for §5.7.2.1</p> <p>§5.1.2 / §5.9.2 Requirement to repeat commissioning with B units removed.</p> <p>§5.7.2.1 TDB upon applicable RF uplink level solved</p> <p>§5.7.2.3 TM(1,9) added to minimum TM configuration for autonomous actions observability</p> <p>§5.7.3.4 Power SCOE setting for LPS configuration added (was missing), as well as a recall of required SAS settings</p> <p>§5.8.2.4.4.2 ACC time synchronisation check added after ACC turn ON.</p> <p>§5.8.2.4.4.7 NCR-3472 experience return : a check and confirmation of the RM alarm input state is added</p> <p>§5.8.3.5 CDMS commissioning § COCOC and CROME register dump limited to readable and meaningful register</p> <p>§5.8.3.5 SSMM "formatting" clarified. Dump area modified to retrieve more meaning data, while not yet the whole SSMM area to save test time.</p> <p>§5.8.3.6 CCU commissioning § updated as after common understanding with ASER.</p> <p>§5.8.3.7 PCS commissioning § clarified (no specific test needed).</p> <hr/> <p>§5.8.3.6 ACMS commissioning § COCOC and CROME register dump limited to readable and meaningful register.</p>	
--	--	--

6.0	December 20 <sup>th</sup> 2007	<p>§5.8.4.5.2 SPIRE spectrometer commissioning test § deleted after removal of SPIRE spectrometer testing from S/C IST scope (i.e. cryostat cannot operate in the horizontal position as suitable for SPIRE spectrometer test).</p> <p>§5.8.5.5 Update of the procedure to take into account better understanding of SW operation, thanks to Herschel and Planck debug experience return.</p> <p>§5.8.5.12 §5.8.5.13 Forced transition to aligned on TAS-I procedure</p> <p>§5.8 Several small configuration and commanding corrections, specifically in S/C state table, after experience return from debug session.</p> <p>§5.9.2 Typings corrected in table</p> <p>§5.9.2 / §5.1.2 Requirement to repeat commissioning with B units removed.</p> <p>§5.8.12 Experience return from debug (jamming) entered</p> <p>§9 System requirement recall moved to RD107.</p> <p>§12.4 Update of packet store definition to fit CDMS ASW V3 SSMM map</p> <p>§12.5 PACS APID correction, and service 18 usage by PACS</p> <p>§19.1 SK03 corrected</p>	P. COUZIN G. BEAUFILS
		<p>§1.1.3 Present issue status update</p> <p>§5.7.6 Obsolete ref. to launch sequence deleted, and Modification log added above for §5.8.12 as those changes were lost in issue 5 official version, after a last minute error in the distributed file issue</p>	
		<p>Instrument related requirements imported from RD106, as per EDSA (F.P.) mail " Inputs to the Herschel IST Spec from TS-1083", December 17<sup>th</sup>.</p> <p>Some wording have been adapted with respect to mail, to adapt them to their new paragraph context. Modified text is highlighted.</p> <p>§3.2 introducing paragraph added to introduce</p> <p>§3.2.1.2 added (§3.2.1.1 title created) to house requirements about launch locks.</p> <p>§3.2.4 added for test sequence logic between S/C IST and SPT</p> <p>§3.3 Some cryostat requirement added</p> <p>§8.3.1.3 Requirements added for instrument assessment reports.</p> <p>§8.3.2.2 Requirements added for instrument evaluation report.</p>	
		<p>Thanks to the Herschel and Planck AIT engineering teams for their support.</p>	

## TABLE OF CONTENTS

<b>1. TEST OBJECTIVES.....</b>	<b>24</b>
1.1. INTRODUCTION .....	24
1.1.1. <i>Scope of the document</i> .....	24
1.1.2. <i>Notice on the "IST" abbreviation usage</i> .....	24
1.1.3. <i>Present issue status</i> .....	26
1.2. TEST OBJECTIVES .....	27
1.2.1. <i>S/C IST objective</i> .....	27
1.2.2. <i>Add on objectives: contribution to instrument validation</i> .....	29
1.2.3. <i>Practical limitation of ambient testing</i> .....	30
<b>2. DOCUMENTS.....</b>	<b>31</b>
2.1. APPLICABLE DOCUMENTS .....	31
2.2. REFERENCE DOCUMENTS.....	32
2.2.1. <i>Generic documents</i> .....	32
2.2.2. <i>Documents for S/C general operation procedure design</i> .....	32
2.2.3. <i>Documents for CDMS operation procedure design</i> .....	33
2.2.4. <i>Documents for ACMS operation procedure design</i> .....	34
2.2.5. <i>Other Reference documents</i> .....	35
2.3. ACRONYMS.....	37
<b>3. TEST SPECIMEN DEFINITION .....</b>	<b>41</b>
3.1. SATELLITE AND GSE CONFIGURATION .....	41
3.1.1. <i>Satellite configuration</i> .....	41
3.1.2. <i>GSE configuration</i> .....	42
3.1.3. <i>AVM and "S/C IST debug" caseS</i> .....	44
3.2. INSTRUMENTS .....	45
3.2.1. <i>Instrument configuration</i> .....	45
3.2.1.1. General configuration requirements .....	45
3.2.1.2. Instrument FPU launch lock during IST/SPT tests .....	45
3.2.1.2.1. SPIRE SMEC Launch lock .....	46
3.2.1.2.2. PACS Grating launch lock .....	46
3.2.2. <i>Instrument IEGSE &amp; GSE</i> .....	46
3.2.3. <i>Instrument team involment in S/C ist test</i> .....	46

3.2.4.	<i>Instrument test during IST aNd SPT</i> .....	47
3.2.4.1.	Instrument tests during IST/SPT: .....	47
3.2.4.2.	Time Allocation for instruments tests .....	48
3.3.	CRYOSTAT .....	48
<b>4.</b>	<b>TEST FACILITY REQUIREMENTS</b> .....	<b>50</b>
<b>5.</b>	<b>TEST DEFINITION</b> .....	<b>51</b>
5.1.	GENERAL INTRODUCTION AND DRIVING REQUIREMENTS .....	51
5.1.1.	<i>Nominal and degraded cases (foreword)</i> .....	51
5.1.2.	<i>Global test timeline</i> .....	52
5.1.3.	<i>Nominal and redundant hardware testing</i> .....	54
5.1.4.	<i>TEST case frame</i> .....	55
5.2.	MOVED TO 5.1.3.....	56
5.3.	MOVED TO 5.1.4.....	56
5.4.	MERGED IN 5.1.4 .....	56
5.5.	TEST CHAINING.....	56
5.6.	TEST SAFETY, SUCCESS CRITERIA, NOGO AND SEQUENCE RESUMING.....	57
5.6.1.	<i>Test safety and sequence resuming</i> .....	57
5.6.2.	<i>Success criteria</i> .....	58
5.6.3.	<i>GO / NO GO conditions</i> .....	58
5.7.	GENERAL TECHNICAL REQUIREMENTS .....	59
5.7.1.	<i>On board data storage</i> .....	59
5.7.1.1.	SSMM initialisation and shut down requirements .....	59
5.7.1.2.	Packet store routine operation requirements.....	59
5.7.1.3.	Packets stores, RM logs, CEL and event buffers recovery requirements.....	60
5.7.2.	<i>Umbilical TM-TC link and RF link usage</i> .....	61
5.7.2.1.	General requirements .....	61
5.7.2.2.	Simulated DTCP operation, general requirements .....	63
5.7.2.3.	Operation with 500bps 5kbps downlink requirements.....	65
5.7.3.	<i>GSE programming requirements</i> .....	66
5.7.3.1.	ACMS environment simulation requirements .....	66
5.7.3.1.1.	Simulation date, ephemerides and orbit propagation .....	66
5.7.3.1.2.	Applicable MCI and Thrust data .....	66
5.7.3.1.3.	Alignment and other ACMS perturbation data.....	66
5.7.3.2.	ACMS safe state in case of test incident requirements .....	67
5.7.3.3.	CCS programming .....	67



5.7.3.4.	POWER SCOE programming .....	67
<i>5.7.4.</i>	<i>CRYOSTAT related operation .....</i>	<i>68</i>
5.7.4.1.	CRYOSTAT state according sequence .....	68
5.7.4.2.	CRYOSTAT V501, V503, V103, V106 activation by the S/C .....	68
5.7.4.3.	CCU usage and CRYOSTAT monitoring constrains.....	69
<i>5.7.5.</i>	<i>S/C overall configuration requirements.....</i>	<i>69</i>
<i>5.7.6.</i>	<i>Flight BAttery usage requirements.....</i>	<i>70</i>
5.8.	NOMINAL CASES .....	70
<i>5.8.1.</i>	<i>Test sequences .....</i>	<i>70</i>
<i>5.8.2.</i>	<i>Launch phase, separation and post separation activities .....</i>	<i>72</i>
5.8.2.1.	Objective .....	72
5.8.2.2.	Test brief description.....	72
5.8.2.3.	Initial S/C configuration (before turn ON).....	74
5.8.2.4.	Test steps .....	76
5.8.2.4.1.	General requirements.....	76
5.8.2.4.2.	Satellite power ON in "minimum" configuration.....	77
5.8.2.4.3.	Short unit health check.....	80
5.8.2.4.4.	Configuration for launch.....	81
5.8.2.4.4.1.	End of SSMM formatting.....	81
5.8.2.4.4.2.	ACMS turn ON and configuration.....	81
5.8.2.4.4.3.	TCS configuration .....	83
5.8.2.4.4.4.	TTC-RF configuration .....	84
5.8.2.4.4.5.	CDMS tables check .....	84
5.8.2.4.4.6.	BATTERY / PCDU verification.....	85
5.8.2.4.4.7.	CDMS and ACMS RM state verification.....	85
5.8.2.4.5.	Launch.....	87
5.8.2.4.6.	Separation .....	89
5.8.2.4.7.	Post separation.....	91
5.8.2.4.8.	Initial check out in SAM mode .....	93
5.8.2.4.9.	CDMS transition to NOM mode .....	96
5.8.2.4.10.	Orbit Control Manoeuvre.....	98
5.8.2.4.11.	End of the sequence.....	100
5.8.2.5.	End of the test .....	100
<i>5.8.3.</i>	<i>Satellite Commissioning.....</i>	<i>101</i>
5.8.3.1.	Objective .....	101
5.8.3.2.	Test brief description.....	102
5.8.3.3.	Test start configuration.....	102
5.8.3.4.	TTC commissioning .....	103

5.8.3.5.	CDMS commissioning.....	105
5.8.3.6.	Moved .....	106
5.8.3.7.	PCS commissioning .....	106
5.8.3.8.	CCU (cryostat) commissioning.....	106
5.8.3.9.	ACMS commissioning .....	106
5.8.3.10.	SREM commissioning .....	107
5.8.3.11.	TCS commissioning .....	108
5.8.3.12.	Telescope decontamination.....	108
5.8.3.13.	Cryo Cover opening .....	109
5.8.3.14.	Test end .....	110
<b>5.8.4.</b>	<b><i>Instruments commissioning and performance verification .....</i></b>	<b>112</b>
5.8.4.1.	Objective .....	112
5.8.4.2.	Test brief description.....	112
5.8.4.3.	Test start (restart) configuration .....	113
5.8.4.4.	Success criteria .....	114
5.8.4.5.	SPIRE commissioning test .....	115
5.8.4.5.1.	SPIRE photometer commissioning test .....	115
5.8.4.5.2.	SPIRE spectrometer complementary commissioning test .....	115
5.8.4.6.	PACS commissioning test .....	116
5.8.4.7.	HIFI commissioning test .....	117
5.8.4.8.	SPIRE and PACS parallel mode.....	118
5.8.4.9.	Test end .....	119
<b>5.8.5.</b>	<b><i>Mode transitions.....</i></b>	<b>120</b>
5.8.5.1.	Objective .....	120
5.8.5.2.	Test brief description.....	120
5.8.5.3.	Test start configuration.....	123
5.8.5.4.	Launch to Launch .....	124
5.8.5.5.	Launch to SAM .....	125
5.8.5.5.1.	Preparatory task .....	125
5.8.5.5.2.	Transition sequence .....	125
5.8.5.6.	SAM to SAM .....	127
5.8.5.6.1.	Preparatory tasks .....	127
5.8.5.6.2.	Transition sequence .....	127
5.8.5.7.	SAM to NOM .....	129
5.8.5.7.1.	Preparatory tasks .....	129
5.8.5.7.2.	Transition sequence .....	129
5.8.5.8.	NOM to NOM.....	131
5.8.5.8.1.	Preparatory tasks .....	131

5.8.5.8.2. Transition sequence .....	132
5.8.5.9. NOM to EAM .....	134
5.8.5.9.1. Preparatory tasks .....	134
5.8.5.9.2. Transition sequence part 1 .....	134
5.8.5.9.3. Transition sequence part 2 .....	135
5.8.5.10. EAM to EAM .....	137
5.8.5.10.1. Preparatory tasks .....	137
5.8.5.10.2. Transition sequence .....	137
5.8.5.11. EAM to NOM .....	138
5.8.5.11.1. Preparatory tasks .....	138
5.8.5.11.2. Transition sequence .....	139
5.8.5.12. NOM to SM.....	140
5.8.5.12.1. Preparatory tasks .....	140
5.8.5.12.2. Transition sequence .....	140
5.8.5.13. SM to SM .....	142
5.8.5.13.1. Preparatory tasks .....	142
5.8.5.13.2. Transition sequence .....	142
5.8.5.14. SM to SAM .....	144
5.8.5.14.1. Preparatory tasks .....	144
5.8.5.14.2. Transition sequence .....	144
5.8.5.15. SAM to SM (deleted) .....	145
5.8.5.16. EAM to SM (deleted) .....	145
5.8.5.17. EAM to SAM (needs new SAM to NOM and NOM to EAM) .....	146
5.8.5.17.1. Preparatory tasks .....	146
5.8.5.17.2. Transition sequence .....	146
5.8.5.18. NOM to SAM (needs new SAM to NOM).....	148
5.8.5.18.1. Preparatory tasks .....	148
5.8.5.18.2. Transition sequence .....	148
5.8.5.19. Test end .....	149
<b>5.8.6. S/C reconfiguration .....</b>	<b>150</b>
5.8.6.1. Test brief description .....	150
5.8.6.2. Test start configuration.....	151
5.8.6.3. CDMS level 3a .....	152
5.8.6.3.1. Preparatory tasks .....	152
5.8.6.3.2. Transition sequence .....	152
5.8.6.4. CDMS level 3b .....	154
5.8.6.4.1. Preparatory tasks for part 1 .....	154
5.8.6.4.2. Transition sequence part 1 .....	154
5.8.6.4.3. Preparatory tasks for part 2 .....	155

---

5.8.6.4.4. Transition sequence part 2 .....	155
5.8.6.5. ACMS level 4 .....	157
5.8.6.5.1. Preparatory tasks .....	157
5.8.6.5.2. Transition sequence .....	158
5.8.6.6. ACMS recovery from Survival Mode (ACMS SASM to SAM).....	160
5.8.6.6.1. Preparatory tasks .....	160
5.8.6.6.2. Transition sequence .....	160
5.8.6.7. CDMS level 4 .....	162
5.8.6.7.1. Preparatory tasks .....	162
5.8.6.7.2. Transition sequence .....	163
5.8.6.8. Test end .....	165
<b>5.8.7. CDMS management.....</b>	<b>166</b>
5.8.7.1. Objective .....	166
5.8.7.2. Test requirements .....	166
5.8.7.2.1. General sequence .....	166
5.8.7.2.2. MTL management.....	168
5.8.7.2.3. OBCP management.....	168
5.8.7.2.4. SSMM management .....	168
5.8.7.2.5. FDIR level 1 and level 2 .....	168
5.8.7.2.6. (transferred in §5.8.13)OBT management .....	169
<b>5.8.8. DTCP worst case scenario .....</b>	<b>169</b>
5.8.8.1. Objective .....	169
5.8.8.2. Test requirements .....	170
5.8.8.2.1. Background operation .....	170
5.8.8.2.2. Specific requirements .....	172
<b>5.8.9. REFERENCE Mission Scenario.....</b>	<b>174</b>
5.8.9.1. Objective .....	174
5.8.9.2. Test start configuration.....	174
5.8.9.3. Test steps .....	176
5.8.9.4. HIFI OD .....	180
5.8.9.5. PACS OD .....	180
5.8.9.6. SPIRE OD .....	180
5.8.9.7. Test end .....	180
5.8.9.8. Success criteria .....	181
<b>5.8.10. Launch clean run.....</b>	<b>182</b>
5.8.10.1. Objective .....	182
5.8.10.2. Test brief description.....	182
5.8.10.3. Success criteria .....	183

---

<i>5.8.11. Launch sequence robustness</i> .....	184
5.8.11.1. Objective .....	184
5.8.11.2. Test description.....	184
5.8.11.3. Test steps .....	185
5.8.11.3.1. General requirements .....	185
5.8.11.3.2. Satellite power ON .....	185
5.8.11.3.3. Short unit health check.....	185
5.8.11.3.4. Configuration for launch.....	185
5.8.11.3.5. Configuration for launch.....	185
5.8.11.3.6. Separation .....	188
5.8.11.3.7. S/C acquisition .....	189
5.8.11.3.8. Initial check out in SAM mode .....	190
5.8.11.3.9. Transition to NOM mode .....	194
5.8.11.3.10. Orbit Control Manoeuvre .....	194
<i>5.8.12. NOM mode robustness</i> .....	195
5.8.12.1. Objective .....	195
5.8.12.2. Test description.....	195
5.8.12.3. Test steps .....	197
5.8.12.3.1. Initial state for first sub-sequence (Normal Science at L2, autonomy period).....	197
5.8.12.3.2. CDMS PM 1553 BC failure simulation .....	199
5.8.12.3.3. CDMS PM 1553 BC failure recovery .....	201
5.8.12.3.4. Initial state second test (Normal Science at L2, autonomy period).....	202
5.8.12.3.5. ACMS 1553 RT failure simulation .....	203
5.8.12.3.6. ACMS 1553 RT failure recovery.....	204
<i>5.8.13. Test of INstrument FDIR OBCP</i> .....	207
5.8.13.1. Objective .....	207
5.8.13.2. RD117 cross-reference.....	207
5.8.13.3. Test requirements .....	207
5.8.13.4. SPIRE FDIR OBCP.....	208
5.8.13.5. PACS FDIR OBCP .....	209
5.8.13.6. HIFI FDIR OBCP.....	209
5.8.13.7. Success criteria .....	210
5.9. DEGRADED CASES .....	211
<i>5.9.1. S/C ability to be operated in degraded modes</i> .....	211
5.9.1.1. Objective .....	211
5.9.1.2. Test description.....	211
<i>5.9.2. Detailed test sequence Start configuration</i> .....	212

<b>6. SUCCESS CRITERIA .....</b>	<b>219</b>
6.1. DETAILED APPLICABLE CRITERIA.....	219
6.2. NO GO CONDITIONS.....	219
6.3. "OUT OF LIMIT" AND TC CHECKING.....	219
6.3.1. <i>BASIC Principle</i> .....	219
6.3.2. <i>Out of limit condition hierarchy</i> .....	221
<b>7. ORGANISATION AND RESPONSIBILITIES .....</b>	<b>222</b>
7.1. ORGANISATION .....	222
7.1.1. <i>General organisation</i> .....	222
7.1.2. <i>Instrument team support</i> .....	223
7.1.2.1. Instrument team support to S/C monitoring.....	223
7.1.2.2. Instrument team involvement in GO-NOGO.....	223
7.1.2.3. Instrument team involvement in (first level) test success confirmation .....	223
7.1.2.4. Post analysis.....	224
7.1.3. <i>Test observation by ESA team</i> .....	224
7.2. RESPONSIBILITIES .....	224
7.3. TASK DISTRIBUTION .....	225
<b>8. DOCUMENTATION.....</b>	<b>227</b>
8.1. DOCUMENTS REQUIRED BEFORE THE TEST .....	227
8.2. DATA ACQUIRED DURING THE TEST .....	227
8.3. DOCUMENTS ISSUED AFTER THE TEST .....	228
8.3.1. <i>Test Reports</i> .....	228
8.3.1.1. Specimen AIT reports.....	228
8.3.1.2. Test environment .....	228
8.3.1.3. Instrument assessment report .....	228
8.3.2. <i>Evaluation reports</i> .....	229
8.3.2.1. Evaluation report for S/C .....	229
8.3.2.2. Evaluation report for the instrument.....	229
<b>9. APPENDIX 1 : IST 1 VERIFIED REQUIREMENTS .....</b>	<b>231</b>
<b>10. THE DETAILS ARE PROVIDED BY RD107.APPENDIX 2: SATELLITE STATE SUMMARY TABLES .....</b>	<b>232</b>
10.1. GENERAL TABLE ORGANISATION .....	232
10.2. CDMS MODE .....	233
10.3. TM / OBT.....	233



# Herschel S/C IST specification

REFERENCE: H-P-2-ASP-SP-0939

DATE: December 20<sup>th</sup> 2007

ISSUE: 6.0

Page : 21

---

10.4.	PM & SW .....	234
10.5.	SCBP / MTL.....	235
10.6.	FDIR / SRVCBH .....	236
10.7.	LAUNCH STRAPS .....	237
10.8.	PCDU IF / CBH .....	237
10.9.	BAT .....	238
10.10.	POWER DOMAIN .....	239
10.11.	SSMM .....	240
10.12.	NOTE .....	240
10.13.	RX1 / RX2 RATE.....	240
10.14.	TME / TX RATE .....	241
10.15.	Tx CHAIN.....	242
10.16.	RX 1 ANT AND RX 2 ANT .....	243
10.17.	CCU.....	245
10.18.	SPIRE .....	246
10.19.	PACS MODE.....	247
10.20.	HIFI MODE .....	248
10.21.	ACMS MODE.....	249
10.22.	PM & SW & B .....	250
10.23.	CRS / FDIR.....	251
10.24.	GYROS.....	252
10.25.	STR.....	252
10.26.	RW .....	253
10.27.	LV.....	254
10.28.	THR .....	255
10.29.	VMC, SREM.....	256
10.30.	POWER SOURCE .....	257
10.31.	TM TC SOURCE.....	257
10.32.	ENV SIMULATOR .....	258
<b>11.</b>	<b>APPENDIX 3: OPERATION GENERAL PROCEDURE SPECIFICATION .....</b>	<b>259</b>
<b>12.</b>	<b>APPENDIX 4 : SSMM INITIALIZATION .....</b>	<b>260</b>
12.1.	SSMM TURN ON AND SSMM BSW SERVICE INITIALISATION .....	260
12.2.	SSMM MANAGEMENT INITIALISATION .....	260

12.3.	STORE STATUS CHECK .....	261
12.4.	PACKET STORE CREATION .....	261
12.4.1.	<i>MTL, OBCP and auxiliary buffers allocAtion</i> .....	261
12.4.2.	<i>1 BANK case</i> .....	262
12.4.3.	<i>3 BANK CASE</i> .....	262
12.4.4.	<i>IMplementation note</i> .....	262
12.5.	DEFINE PACKET STORE SELECTION CRITERIA .....	263
<b>13.</b>	<b>APPENDIX 5 : ACMS SETTINGS FOR TEST</b> .....	<b>265</b>
13.1.	REFERENCES .....	265
13.2.	INTRODUCTION .....	265
13.3.	SOFTWARE VERSION .....	265
13.4.	STARTING CONDITIONS .....	265
13.5.	SEQUENCE OF COMMANDING .....	266
13.5.1.	<i>Command a fine pointing</i> .....	266
13.5.2.	<i>Command AFO mode</i> .....	266
13.5.3.	<i>Command a fine pointing in SSO after a slew of 2° around Y</i> .....	267
13.5.4.	<i>Command a Line scanning with off position,</i> .....	268
13.5.5.	<i>Command four nodding arranged as 2x2 raster</i> .....	268
13.5.6.	<i>Command a slew near the border of the ADD zone</i> .....	270
13.5.7.	<i>Command interlacing while staying at the same direction</i> .....	270
13.5.8.	<i>Command a slew back to sun pointing with interlacing activated</i> .....	270
<b>14.</b>	<b>APPENDIX 6 : LCL LIST</b> .....	<b>272</b>
<b>15.</b>	<b>APPENDIX 7: TBC TBD AND TBW LIST</b> .....	<b>276</b>
<b>16.</b>	<b>APPENDIX 8: S/C CDMS AND ACMS OPERATING MODES</b> .....	<b>277</b>
<b>17.</b>	<b>APPENDIX 9: ALARM CASE VERIFICATION TEST MATRIX</b> .....	<b>283</b>
<b>18.</b>	<b>APPENDIX 10: AVM S/C IST APPLICABILITY MATRIX</b> .....	<b>287</b>
18.1.	SEQUENCE PRIORITY .....	287
18.2.	CONSIDERED SEQUENCE ADAPTATION FOR AVM TEST .....	288
18.2.1.	<i>Launch sequence</i> .....	288
18.2.2.	<i>S/C reconfiguration, degraded cases, DTCP worst case scenario</i> .....	288
18.2.3.	<i>Reference Mission Scenario</i> .....	288
18.2.4.	<i>Instrument commissioning</i> .....	289

---

18.2.5. Mode transitions.....	289
18.2.6. Launch clean run.....	289
18.2.7. CDMS management.....	289
18.2.8. S/C commissioning .....	289
<b>19. APPENDIX 11: EGSE CONFIGURATION ELEMENTS.....</b>	<b>290</b>
19.1. S/C SKIN PLUG CONFIGURATION .....	290
19.2. S/C LATCHING RELAYS .....	291
<b>20. APPENDIX 12: TEST MTL FOR MODE TRANSITION AND S/C RECONFIGURATION .....</b>	<b>292</b>
20.1. BACKGROUND "MTL TEST PATTERN" SUBSCHEDULE.....	292

## 1. TEST OBJECTIVES

### 1.1. INTRODUCTION

#### 1.1.1. SCOPE OF THE DOCUMENT

The Spacecraft Integrated Satellite Test (S/C IST) is a set of functional tests, performed on the fully integrated satellite as part of its final test sequence.

The objective of the present S/C IST specification is to provide requirements to Satellite AIT engineering, with sufficient details in order to design and write the relevant S/C IST procedures, and to define the necessary configuration of the Ground Support Equipment and the other test facilities.

The Instruments functional tests and the verification of their proper interaction with the full satellite in flight representative situations are part of S/C IST (flight representativeness as far as allowed by ambient ground test condition).

It shall be pointed out that no test requiring manual intervention or intrusive measurement on S/C itself (ex: breakout box) will nominally be run during S/C IST. Any exception will be clearly stated.

The present specification is applicable to the Herschel Satellite.

#### 1.1.2. NOTICE ON THE "IST" ABBREVIATION USAGE

The IST abbreviation stands for "Integrated Satellite Test". It is unfortunately used in the Herschel-Planck project documentation with several confusing deviations.

The IST abbreviation is sometime translated as "Integrated System Test". This shall be considered as a synonym.

To prevent confusion with the "SVM IST" (see below), the IST as defined by this specification is increasingly referred as "S/C IST" or "SAT IST" (S/C and SAT standing for "satellite").

The project history has led also to define tests, whose names include the IST acronym, without being related to the scope and objective of the S/C IST as defined by this document. For clarity, please find hereafter some recall and definition.

- The "**mini IST**" is a special test that has been introduced as a prerequisite to the Planck PFM1 test. Its objective was the validation of the test sequences, resources and procedures which were needed for running the PFM1 test. This test has been run on a partially integrated Planck configuration in clean room environment (SVM+PPLM).

The PFM1 test was a thermal vacuum balance test, whose objective was the S/C thermal model validation (no STM model for Planck). The "mini IST" is related with the herein specified IST in the way that some of its sub-sequences and procedures have been inherited by the Planck S/C IST, and through commonality, by Herschel S/C IST.

- The **"SVM IST"** is the final integrated test performed by TAS-I on the service modules (SVM) to conclude its validation. There is one Herschel "SVM IST" and one Planck "SVM IST".

The Herschel "SVM IST" is tightly related with the herein S/C IST. It shall validate most satellite functions: in principle, all except the detailed interaction with the instruments. The S/C IST and the "SVM IST" are complementary in the frame of the satellite validation.

- The **"IST1"** and **"IST2"** acronyms are used to designate the first and second run of the S/C IST. The S/C IST shall be run twice on the satellite (baseline). This is detailed in chapter 1.2.1.
- The **"combined IST"** is the name which has been given at a time, to one merger for Planck, of "SVM IST" and the "IST1". The "combined IST" was applicable to Planck only, and is no more considered.
- The **"AVM IST"** was originally a preparatory run of the S/C IST –as defined in this document– on the AVM model. The major objective of this test was to validate the S/C IST test sequences and procedures. This task of debugging the S/C IST test sequences and procedures has been since reprogrammed for using any available test slot on Herschel PFM, AVM-PFM composite assembly.

The "S/C IST debug" terminology has been introduced to refer those tests led on more numerous and changing configurations.

The applicability of this document to the "AVM S/C IST" / "S/C IST debug" is presented in chapter 3.1.3.

The above list of the IST acronym usage is not necessarily exhaustive. For example, IST for "Instrument Specific Test" has had some usage. But this paragraph shall clarify all the confusing cases with respect to this document context.

### 1.1.3. *PRESENT ISSUE STATUS*

This document issue 6.0 takes into account latest ESA comments on issue 5.0, and specifically the inclusion of some instrument related requirements which were previously managed by call to RD106.



## 1.2. TEST OBJECTIVES

### 1.2.1. S/C IST OBJECTIVE

The objective of Herschel S/C IST is twofold:

- to verify the correct functional performances of the satellite and the compatibility between all the integrated electrical subsystems and instruments,
- to validate the baseline of the operation procedures which will be exercised during the different phases of the satellite mission.

Except where otherwise stated, the S/C IST shall be:

- a fully automated test run from the Central Checkout System (CCS),
- utilising the Herschel Planck System Data Base (HPSDB) and,
- dedicated test procedures and control files developed to verify the performances of the satellite subsystems and instruments with each other.

The S/C IST shall be essentially composed of a succession of mission representative tests, including especially the test of the special and routine operation profiles defined by the Reference Mission Scenario [RD02] (RMS) for the satellite, as well as some degraded operation cases.

The basic requirement is the following (SRS requirement):

AIAI-70: The purpose of the Integrated Satellite Test (IST) shall be to verify correct operation of the fully integrated satellite in a series of representative mission modes including autonomous (Mission Timeline – MTL and On-Board Control Procedures – OBCP) and backup modes.

For that, the S/C IST is structured into a limited number of independent test sequences. The whole S/C IST or only part of it, may be possibly replayed at different times in the satellite test campaign. The satellite EMC test campaign will be so typically based on re-assembled and rescheduled S/C IST sub-sequences. The satellite Thermal Vacuum test campaign will include as part of its program, the replay of some of the S/C IST sequences.

The S/C IST shall be the reference test for the satellite functional check-out and its formal run shall be performed after that:

- the electrical subsystems and the instruments are successfully integrated onto the satellite,
- the tests of the subsystems in the system environment are all completed (PCS SIT, CDMS SIT, TTC SIT, ACMS SIT, etc.),
- the instrument integration and tests (ILT, UFT) are completed (warm units and cold units),
- the HPSDB, including FDDB, is properly populated and under strict configuration control,

- the CDMS and ACMS BSW and ASW are in stable versions (definitive "flight branch") and under strict configuration control,
- the generation and the validation of the necessary OBCP have been done (with the subtlety that this validation is a nominal part of S/C IST debug).

This document baseline is that the S/C IST shall be nominally run twice on the satellite in complete flight configuration, during the phase D of the program:

- the IST1 shall be run at the beginning of the FM satellite environment test campaign, after the I&T, UFT and SIT activities have been run, with all instruments integrated,
- the IST2 shall be run at the end of the environmental test campaign of the FM satellite.

After project constrain evolutions, this maybe amended, specifically with respect to used software issues (CDMS, ACMS, and/or instruments). An another questioned point, is the merging of S/C IST objective with some instrument SPT ones (which implies to run the S/C IST with cryostat in He-II condition).

The management of those evolutions led by project overall planning optimisation, is out of the scope of this document. The document ignores so those (possible) evolution, and impacts will have to be managed on a case by case basis if relevant. To permit a straightforward comparison of the 2 S/C IST run results, the tests shall also be, in principle, identical. In practice, if not the above mentioned evolutions, the subsystems, instruments and/or on board software development will likely affect the strict identity of the 2 tests with some last minute bug fix. Those constraints will have to be handled individually through NCR.

The present test specification is fully applicable, in principle, to the IST1 and IST2 runs.

## Important notes:

In order to ease test design and to maintain a consistent approach for the S/C IST runs, while taking into account the above mentioned restrictions, the S/C IST specification is structured into smaller and modular self standing elementary test specifications. There is so a very large flexibility down to daily test programming.

At S/C IST stage, it is made use –to the maximum extent– of implicit testing, meaning that a number of functions are implicitly tested by using these functions, while explicitly testing other satellite system functions. All the functions therefore do not need to be validated in a explicitly dedicated session.

Some system requirements shall be explicitly verified during IST1 and IST2. A matrix recalling them is given in appendix 1 as a guideline for the test post-analysis.

Despite the specification goes deep in some details on some test points to make clear some else possibly ambiguous test conditions, this specification aims at remaining a high level specification: that is specify actions in "functional" terms, to be independent as much of possible of the SW commanding implementation details.

This means specifically that this specification is not written to save the reader for reading the S/C, SVM, instruments, sub-system or unit user manuals to determine how the S/C shall be exactly operated to obtained the specified functional behaviour, and the related observable that shall be correlatively checked.

Correlatively, the satellite S/C state tables has been introduced in the specification, as an element to ease test sequence understanding. Its fulfilment shall not be considered as a sufficient criteria to determine test success, when User Manual instructed checks would at the same time fail.

## 1.2.2. ADD ON OBJECTIVES: CONTRIBUTION TO INSTRUMENT VALIDATION

For project history related reasons, the instrument integration tests will not be fully completed before the Herschel IST1 test.

The IST1 objective shall be combined with the instrument functional and performance validation test (SPT).

A fact is, that the instrument functional and performance validation will be done in flight during the instrument commissioning period. The flight procedures for those tests shall be validated in the frame of the IST. So some of the SPT and S/C IST tests may combine nicely.

But the actual instrument performance validation objective during the S/C IST has many impacts.

The actual instrument performance validation requires that they are set-up in a fully acceptable state for the performance measure. Beside the ambient testing condition for warm units and LOU, this shall specifically account for the focal plane thermal condition.

A specific impact is that the cryostat shall be operated in He-II condition, and that the focal plane thermal time constant shall be respected (in fact measured), with constraints on the instrument activation order and sorption coolers operating cycles (which shall be measured).

This means also that the CRYO-SCOE support will be necessary to run the tests.

With respect to IST objective, this comes mainly with:

- the impossibility to accelerate some of the test sequences,
- the need to keep some S/C operation round the clock (to get continuous CCU data), or to switch CRYOSCOE configuration daily (some of the critical cryostat sensors are not available in parallel for CCU and SCOE reading. When CCU is OFF, CCU shall be unplugged, and SCOE connected instead to ensure the proper cryostat monitoring).

The impact is mainly upon planning and scheduling, and is not managed in the frame of this document. This is left to for optimisation to practical test design and management with cryostat specialists.

The test combination between pure S/C IST (functional) objective and more advanced instrument verification means also that this test specification does not enter in the instrument state and commanding details, shall be completed for that by the "Test specification for Herschel Instruments AVM and PFM tests performed at satellite level" (RD106) chapters dedicated to S/C IST (this document manages all the instrument tests run at S/C level in a single reference to ensure they are coherent and complementary).

### 1.2.3. PRACTICAL LIMITATION OF AMBIENT TESTING

The IST1 and IST2 shall be run in ambient clean room environment.

For Herschel, the ambient environment brings some limitation because:

- the HIFI instrument has strict limitations when LOU is operated at ambient temperature (flight representative one is about 120°K). This mainly accounts for a power limitation on LOU outputs and the unavailability of the upper frequency channels.
- the cryoharness strands are not at a representative temperature, then wire impedance is higher than flight with possible bias on fine instrument performance measurements or on other cryostat functionality as the NCA (the firing current should be too low on a representative NCA load).
- the straylight level at the focal plane level remains high due to the 2<sup>nd</sup> shield temperature level in ambient condition.
- the mass flow rate needs to be boosted to compensate thermal inputs and the instrument operation (L1 and L2 temperature).

This means that some instrument performance and even some functional validation will be get anyway only under thermal vacuum condition.

Then the thermal vacuum test (TVTB) sequences will not be simply extracted from the S/C IST, but will be complemented by many specific SPT sequences defined by RD106 which covers all the instrument tests (and not only IST associated ones).

To prevent unnecessary overheating, the thermal control subsystem (TCS) lines needs to be also ensured OFF. To not alter the CDMS ASW operation, this shall be ensured by a proper patching of the TCS tables, so that the ambient temperature reading correspond clearly to a heater OFF command for all the control loop. This biasing of the TCS tables shall be part of the routine S/C turn ON at ambient, then is not specifically recalled for each sequence in the document.

The AIT alternative procedure that consists in disabling all the thermal lines shall not be used during the S/C IST sequence, except to manage the S/C cold turn ON transient. The TCS control loops shall be always enabled during the S/C IST tests, so that the CDMS ASW background TCS tasks process the data in a flight similar way, even if thresholds are biased so that the control law always may only command OFF the heaters in the end.

Note 1 for TVTB: for the sequences replay in the TVTB context, care will have to be taken that this TCS tables biasing is not performed.

Note 2 for TVTB: for the sequences replay in the TVTB context, care will have to be taken that there is no cold panel in front of the STR (baseline configuration), then 1) the active STR will be working at higher temperature than nominal (OOL shall be managed) and 2) the configuration will not support a parallel operation (overheating) so that sequences will have to be modified if they use this S/C configuration.

## 2. DOCUMENTS

### 2.1. APPLICABLE DOCUMENTS

AD03 SOFDIR	System Operation and FDIR Requirements H-P-1-ASPI-SP-0209	for reference: issue 4.4, July 20 <sup>th</sup> 2004
AD04	Herschel equipment with limited cycles H-P-3-ASP-TS-1102	for reference: issue 1.0, March 24 <sup>th</sup> 2006
AD07 S/C UM	HERSCHEL PLANCK S/C USER MANUAL H-P-1-ASP-MA-0693	for reference: issue 2.1 May 31 <sup>st</sup> 2006
AD08 SVM UM	HERSCHEL PLANCK SVM USER MANUAL H-P-MA-AI-0001	for reference: Vol. 1, Herschel Planck user manual, issue 4.0, October 31 <sup>st</sup> 2005 Vol. 2, CMDS, issue 5.0, March 31 <sup>st</sup> 2006 Vol. 3, TTC-RF, issue 5.0, March 31 <sup>st</sup> 2006 Vol. 4, ACMS, issue 5.0, March 31 <sup>st</sup> 2006 Vol. 5, RCS, issue 4.0, October 31 <sup>st</sup> 2005 Vol. 6, PCS, issue 5.0, March 31 <sup>st</sup> 2006 Vol. 7, TCS, issue 4.0, October 31 <sup>st</sup> 2005 Vol. 8, Flight procedures, issue 5.0, March 31 <sup>st</sup> 2006
AD09 HIFI UM	HIFI User Manual SRON-U/HIFI/UM/2004-001	for reference: issue 1.4F, January 18 <sup>th</sup> 2006
AD10 PACS UM	PACS User Manual to be issued	for reference: PACS unit level user manuals
AD11 SPIRE UM	SPIRE Instrument User Manual SPIRE-RAL-PRJ-002395	for reference: issue 1.0, April 8 <sup>th</sup> 2005
AD12 HPLM UM	TBD	
AD13 PSICD	Packet structure ICD SCI-PT-ICD-07527	for reference: issue 5.0, July 20 <sup>th</sup> 2004 with proper amendments (issue 6.0 draft) for appendix 3 (APID allocation), and service 15 TM and TC definition (SSMM pointers)
AD40	Attention items H-P-1-ASP-TN-1481	
AD41	S/C IST test data retrieve instructions H-P-1-ASP-TN-1482	

The latest issues of the above documents are applicable. For reference, are nevertheless given the active issues with which the present specification is coherent. Any discrepancy arising from a later issue will have to be brought to the attention of the contractor for clarification and resolution.

## 2.2. REFERENCE DOCUMENTS

### 2.2.1. GENERIC DOCUMENTS

RD101 VPP	Verification Programme Plan H-P-1-ASPI-PL-0225	for reference: issue 3.0, July 19 <sup>th</sup> 2004
RD102 GDIR	General Design and Interface Requirement H-P-1-ASPI-SP-0027	for reference: issue 5.0, October 7 <sup>th</sup> 2004
RD105 ENV	Environment and tests requirements H-P-1-ASPI-SP-0030	for reference: issue 5.0, October 7 <sup>th</sup> 2004
RD106	Test specification for Herschel Instruments AVM and PF tests performed at satellite level H-P-3-ASP-TS-1083	for reference: issue 1.0, September 29 <sup>th</sup> 2006
RD107	S/C IST system requirement verification matrix H-P	

The latest issues of the above documents are applicable. For reference, are nevertheless given the active issues with which the present specification is coherent. Any discrepancy arising from a later issue will have to be brought to the attention of the contractor for clarification and resolution.

### 2.2.2. DOCUMENTS FOR S/C GENERAL OPERATION PROCEDURE DESIGN

RD114a	SREM FM integration and test procedures H-P-PR-AI-0068	for reference: issue 2, May 2 <sup>nd</sup> 2006
RD114b	SREM User Manual SREM-UM-CSAG-003	for reference: issue 1, April 10 <sup>th</sup> 2001
RD114c	SREM User Manual SREM-DI-CSAG-003	for reference: issue 1.4, February 15 <sup>th</sup> 2002
RD114d	SREM SURD H/P-SREM-SURD-v003	for reference: issue 3, February 11 <sup>th</sup> 2004
RD115	H/P IST Thermal prediction H-P-1-ASP-TN-1170	for reference: issue 1, September 18 <sup>th</sup> 2006

# Herschel S/C IST specification

REFERENCE: H-P-2-ASP-SP-0939

DATE: December 20<sup>th</sup> 2007

ISSUE: 6.0

Page : 33

RD116	Unit Switching Status H-P-1-ASPI-TN-0386	for reference: issue 2.0, dated September 19 <sup>th</sup> 2006
RD117 OBCP SPEC	Payload Management & OBCP H-P-1-ASP-TN-1072	for reference: issue 2.0, dated July 7 <sup>th</sup> 2007
RD118	Radio Frequency and modulation (annex A) ECSS-E-50-05A	
RD119	HPSDB / OBSW ICD H-P-1-ASP-ID-0856	for reference: issue 3.0drft, dated February 23 <sup>rd</sup> 2006

The latest issues of the above documents are applicable. For reference, are nevertheless given the active issues with which the present specification is coherent. Any discrepancy arising from a later issue will have to be brought to the attention of the contractor for clarification and resolution.

## 2.2.3. DOCUMENTS FOR CDMS OPERATION PROCEDURE DESIGN

RD120 CDMS HW UM	CDMU [HW] User Manual H-P-4-SES-NT-0009	for reference: issue 8, April 20 <sup>th</sup> 2006
RD121 CDMS BSW UM	ACC & CDMU Software User Manual H-P-4-SES-NT-0029	for reference: issue 8, February 24 <sup>th</sup> 2006
RD122 CDMS ASW ICD	CDMU ASW ICD H-P-SSF-IC-0001  Note: for CDMS ASW, ICD and UM, content are typically inverted	for reference: issue 3.3, November 10 <sup>th</sup> 2006
RD123 CDMS BSW ICD	CDMU BSW ICD H-P-4-SES-NT-0076	for reference: issue 11, April 5 <sup>th</sup> 2006
RD124 CDMS ASW UM	CDMU ASW User Manual H-P-SSF-IC-0001	for reference: issue 3.1, November 17 <sup>th</sup> 2006
RD125 CDMS TLB	CMDU Application software default on board tables H-P-TN-AI-0145	for reference: issue 2, October 2 <sup>nd</sup> 2006
RD126 CDMS TLM	CDMU Housekeeping packets definition H-P-TN-AI-0100	for reference: issue 1, July 1 <sup>st</sup> 2005
RD127 OBCP ICD	CIDL Herschel OBCP H-P-1-ASP-LI-8941	for reference: issue 1, March 26 <sup>th</sup> 2005
RD128 MTL SPEC	MTL subschedule usage TBD	for reference: ESOC M.S. mail "Herschel RMS MTL" March 23 <sup>rd</sup> 2007.

The latest issues of the above documents are applicable. For reference, are nevertheless given the active issues with which the present specification is coherent. Any discrepancy arising from a later issue will have to be brought to the attention of the contractor for clarification and resolution.

## 2.2.4. DOCUMENTS FOR ACMS OPERATION PROCEDURE DESIGN

RD130 ACMS HW UM	ACMS [HW] User Manual H-P-4-SES-NT-0031	for reference: issue 8, March 30 <sup>th</sup> 2006
RD131 ACMS BSW UM	see RD121	
RD132 ACMS ASW UM1	ACMS User Manual H-P-4-DS-MA-001	for reference: issue 4.1, April 7 <sup>th</sup> 2006
RD133a ACMS ASW UM common FCP	ACMS User Manual, Flight Control Procedures for Herschel / Planck common functionality H-P-4-DS-MA-006	for reference: issue 2.2, November 7 <sup>th</sup> 2006
RD133b ACMS ASW UM common CRP	ACMS User Manual, Contingency Recovery Procedures for Herschel / Planck common functionality H-P-4-DS-MA-008	for reference: issue 1.1, November 23 <sup>rd</sup> 2006
RD134a ACMS ASW FCP	ACMS User Manual, Flight Control Procedures for Herschel S/C H-P-4-DS-MA-007	for reference: issue 2.2, November. 7 <sup>th</sup> 2006
RD134b ACMS ASW CRP	ACMS User Manual, Contingency Recovery Procedures for Herschel S/C H-P-4-DS-MA-009	for reference: issue 2.1, November 23 <sup>rd</sup> 2006
RD134c ACMS ASW GAI	Ground testing attention items H-P-4-DS-MA-010	for reference: issue 1.2, December 12 <sup>th</sup> 2006
RD134d ACMS ASW RWL	Herschel RWL user manual and health check H-P-4-DS-MA-011	for reference: issue 1.0, October 10 <sup>th</sup> 2006
RD135 ACMS ASW CAL	Ground calibration and performance prediction algorithm description H-P-4-DS-TN-041	for reference: issue 2, June 3 <sup>rd</sup> 2006
RD136 ACMS BSW ICD	ACMS BSW ICD H-P-4-SES-NT-0077	for reference: issue 6, November 13 <sup>th</sup> 2006
RD137a ACMS ASW ICD1	ACMS TeleCommand definition H-P-4-DS-TN-024	for reference: issue 4.0, March 15 <sup>th</sup> 2006
RD137b ACMS ASW ICD2	ACMS TeleMetry definition H-P-4-DS-TN-025	for reference: issue 4.0, May 4 <sup>th</sup> 2006



RD138 ACMS ASW ICD3	ACC ASW ICD H-P-4-TASW-IF-0002	for reference: issue 2, September 27 <sup>th</sup> 2006
RD139	Commissioning and Performance Verification plan H-P-1-ASP-TN-1383	for reference issue 1, June 1 <sup>st</sup> 2007

The latest issues of the above documents are applicable. For reference, are nevertheless given the active issues with which the present specification is coherent. Any discrepancy arising from a later issue will have to be brought to the attention of the contractor for clarification and resolution.

## 2.2.5. OTHER REFERENCE DOCUMENTS

RD02 RMS	Reference Mission Scenario, Herschel / Planck project SCI-PT / 12759, issue 3.1, dated August 6 <sup>th</sup> 2004.
RD03	ACMS SIT Test Specification H-P-SP-AI-0059, issue 4, dated October 11 <sup>th</sup> 2006.
RD04	Inhibit Function & Launch and Reconfiguration Sequences H-P-1-ASPI-TN-0903, issue 2.0, dated end of October 2006.
RD05	AIT Software management plan H-P-1-ASP-PL-0420, issue 2.2, dated November 15 <sup>th</sup> 2004.
RD06	Packet store usage on Herschel / Planck PT-CMOC-OPS-TN-6603-OPS, issue 2.1, dated April 2005.
RD07	Instrument testing at PLM PFM and Satellite level HP-2-ASED-PL-0031, issue 2, dated September 3 <sup>rd</sup> 2004.
RD08 SPIRE IID-B	Instrument Interface Document, Part B, instrument "SPIRE" SCI-PT-IIDB/SPIRE-02124, issue 4, dated April 1 <sup>st</sup> 2006.
RD09 HIFI IID-B	Instrument Interface Document, Part B, instrument "HIFI" SCI-PT-IIDB/HIFI-02125, issue 3.3, dated October 21 <sup>st</sup> 2005.
RD10 PACS IID-B	Instrument Interface Document, Part B, instrument "PACS" SCI-PT-IIDB/PACS-02126, issue 4, dated June 2 <sup>nd</sup> 2006.
RD11 AVM SPEC	AVM requirements and design H-P-1-ASPI-TN-0164, issue 2.2, dated December 8 <sup>th</sup> 2003.
RD12	Herschel / Planck AVM technical note H-P-TN-AI-0052, issue 2, dated June 28 <sup>th</sup> 2004.
RD17	Instrument PLM EQM level test procedure HP-2-ASED-PR-0051, issue 1.1, dated June 24 <sup>th</sup> 2005.
RD24 CDMS ASW	CDMU Application software requirement specification H-P-SP-AI-0031, issue 10, dated May 2 <sup>nd</sup> 2007

# Herschel S/C IST specification

REFERENCE: H-P-2-ASP-SP-0939

DATE: December 20<sup>th</sup> 2007

ISSUE: 6.0

Page : 36

SRD	Note 1: new issue that include the "amendments". Note 2: erratum for TTC : in NOM or EAM, redundant Rx is set at 125bps not 4k. This will be corrected in next issue (or amendment...).
RD27	Standard Radiation Environment Monitor test specification SCI-PT-35132, issue 2.0, dated May 11 <sup>th</sup> 2005.
RD30 SRS	System Requirement Specification SCI-PT-RS-05991, issue 3.3, dated July 27 <sup>th</sup> 2004
RD31 OIRD	Operations Interface Requirement Documents SCI-PT-RS-07360, issue 2.2, dated September 31 <sup>st</sup> 2003.
RD34	List of acronyms H-P-1-ASPI-LI-0077, issue 2, July 17 <sup>th</sup> 2004.
RD36	Packet TeleCommand Standard ESA PSS-04-107, issue 2, April 1992
RD37	Link budget report H-P-BD-AI-0005, issue 4, September 2006
RD38	PM41, ESA "Fast L2 Transfer Strategy" presentation April 11 <sup>th</sup> / 12 <sup>th</sup> 2007

The latest issues of the above documents are applicable. For reference, are nevertheless given the active issues with which the present specification is coherent. Any discrepancy arising from a later issue will have to be brought to the attention of the contractor for clarification and resolution.

## 2.3. ACRONYMS

The acronym definitions shall be find in RD34. For convenience, the following list recalls the most useful ones (sometime with comments) and adds a few ones.

Note: the tables summarising the satellite state along sequence steps use additional acronyms. Their specific definition is given in the dedicated appendix 2 (§10).

AAD	Attitude anomaly Detector (part of ACC RM, 1 fail operational unit)
ACC	ACMS Control Computer
ACMS	Attitude Control and Measurement Subsystem
AFO	Autonomous Fail Operational (FDIR mode)
AFS	Autonomous Fail Safe (FDIR mode)
AIT	Assembly Integration and Test
AIR	ACMS In Reconfiguration (see appendix 8)
AP	Autonomous Period (part of OD)
APID	Application Process IDentifier (specifies the identity of a TC packet user)
ASW	Application Software (upper level of OBSW)
AVM	AVionics Model
BATSIM	BATtery SIMulator (see BSSCOE)
BCR	Battery Charge Regulator (part of PCDU, 3 units)
BDR	Battery Discharge Regulator (part of PCDU, 2 units)
BSSCOE	Battery Simulator SCOE (regular AIT designation for BATSIM)
BSW	Basic Software (lower level of OBSW, common to ACC and CDMU)
CCS	Central Check-out System
CDMS	Control and Data Management Subsystem
CDMU	Control and Data Management Unit
CEL	Critical Event Log
CIR	CDMS In Reconfiguration (see appendix 8)
CLCW	Command Link Control Word
COP	Commissioning Operation Phase
CPDU	Command Packet Decoder Unit (part of CDMU RM, 2 units)
CRYO-SCOE	SCOE that ensures the CRYOstat monitoring and management for ground operations.

# Herschel S/C IST specification

REFERENCE: H-P-2-ASP-SP-0939

DATE: December 20<sup>th</sup> 2007

ISSUE: 6.0

Page : 38

CSEL	CPDU Selector (part of CDMU RM, 2 units)
CVV	Cryostat Vacuum Vessel
DFE	Data Front End (SCOE)
DOD	[ battery ] Depth Of Discharge
DPU	Digital Processing Unit (instrument unit which ensures the I/F with the CDMS)
DTCP	Daily TeleCommunication Phase (part of OD)
EGSE	Electrical Ground Support Equipment
ESA	European Space Agency
ESOC	European Space Operation Centre
EVTR	EnVironment and Test Requirement (see RD105)
FDDDB	Flight Dynamics Data Base
FDIR	Failure Detection, Isolation and Recovery
FM	Flight Model
FPU	Focal Plane Units (generally relate to the units inside the cryostat)
GSE	Ground Support Equipment
HPSDB	Herschel-Planck System Data Base
HIFI	Heterodyne Instrument for the Far Infrared
Hk	House Keeping [telemetry]
HPLM	Herschel PayLoad Module
IEGSE	Instrument Electrical Ground Support Equipment
I/F	Interface
ILT	Instrument Level Test
IOP	Initial Orbit Phase (regular name for LEOP)
IST	Integrated Satellite Test
I&T	Integration and Test
LEOP	Launch and Early Operation Phase (see IOP)
LOU	Local Oscillator Unit (part of HIFI)
MAP	Multiplexed Access Point (specifies to the TC decoder the hardware TC packet destination). The possible value for IST are : MAP1 = OBSW (any packet user), MAP0 = CPDU, MAP5 = RM/TRR reset, MAP6 = locks CPDU use for ground TC only (MAP0, MAP5 and MAP6 nominal use is limited S/C ON OFF only or the creation of specific test condition)
MLI	Multi Layer Insulation
MM	Mass Memory (full acronym shall be SSMM)

# Herschel S/C IST specification

REFERENCE: H-P-2-ASP-SP-0939

DATE: December 20<sup>th</sup> 2007

ISSUE: 6.0

Page : 39

MPT	Multi Purpose Trolley
MTL	Mission Time Line
N/A	non applicable
NCA	Non Contaminating Actuator (cryostat cover actuator)
NED	Non Explosive Device (see NCA)
OBCP	On Board Control Procedure
OBDB	On Board Data Base (ACMS)
OBSW	On Board SoftWare (i.e. BSW and/or ASW)
OD	Operation Day
OOL	Out Of Limit
PACS	Photo-detector Array Camera and Spectrometer
PCS	Power Control Subsystem
PCDU	Power Control and Distribution Unit
PM	Processor Module (part of CDMU or ACC)
PFM	Proto Flight Model
PLM	PayLoad Module
PPLM	Planck PayLoad Module
PVP	Performance Validation Phase
RM	Reconfiguration Module (part of CDMU or ACC)
RM-CCS	Compacted Command Sequence (TC sequence run by the RM when triggered)
RMS	Reference Mission Scenario (see reference documents)
ROP	Routine Operation Phase
S/A	Solar Array
SAS	Solar Array Simulator (see SASLPSSCOE)
SASLPSSCOE	Solar Array Simulator and Launch Power Supply SCOE (regular AIT name for SAS)
S/C	SpaceCraft
SCBP	SpaceCraft Bus Profile
SCOE	Special Check-Out Equipment
SDB	[1553] Satellite Data Bus (data handling)
SGM	SafeGuard Memory (part of CDMU and ACC RM, 2 units)
SIT	Subsystem Integrated Test
SIR	Spacecraft In Reconfiguration (see appendix 8)
SOC	[battery] State Of Charge

# Herschel S/C IST specification

REFERENCE: H-P-2-ASP-SP-0939

DATE: December 20<sup>th</sup> 2007

ISSUE: 6.0

Page : 40

SPT	Special Performance Test
SPIRE	Spectral Photometer Imaging REceiver
SRD	Software Requirement Specification (see RD24)
SSMM	Solid State Mass Memory (part of CDMU)
STBY	STand-BY [state] (generic name for the state in which the instrument are inactive but ON to provide housekeeping functions and observability).
SVM	SerVice Module
TC	TeleCommand
TC(t,s [,f[,a]])	TeleCommand reference conform to the PSICD standard: t = type, s = subtype, and where applicable, f = function identification, and a = action identification (see RD25). The used prefix CPDU-, CDMS-, ACMS-, HIFI-, PACS-, SPIRE-, clarifies the destination APID (or the MAP for CPDU case).
TM	TeleMetry
TM(t,s [,f[,a]])	TeleMetry reference conform to the PSICD standard: t = type, s = subtype, and where applicable, f = function identification, and a = action identification (see RD25).
TTC	Telemetry, Tracking and Command [subsystem]
TVTb	Thermal Vacuum and Thermal Balance [test]
UFT	Unit Functional Test
4K	4K cooler

The reader is expected to be familiar with the general satellite design and mission then, the above table does not recall necessarily all acronyms. This is specifically true when addressing the on board unit names (VMC, XPND, TWTA, etc.). The system Design Report, H-P-1-ASP-RP-0666, may be used for clarification when necessary.

## 3. TEST SPECIMEN DEFINITION

### 3.1. SATELLITE AND GSE CONFIGURATION

#### 3.1.1. SATELLITE CONFIGURATION

The satellite shall be mechanically assembled:

- the Service Module shall be assembled and all panels closed (complete MLI installation is not mandatory),
- the Payload Module shall be assembled and integrated onto the SVM,
- the instrument configuration for IST1 and IST2 shall be as defined in RD106,
- the installation of the solar array is not mandatory for IST. In all cases, the Solar Array Simulator shall supply the satellite for test then shall be electrically connected instead of the solar array at the SVM upper brackets level. The simulation provided by the SAS includes the SA thermal sensors. The necessary end to end test after final connection of the real solar array is not part of the IST.

All the electrical subsystems shall be integrated: the relevant I&T, UFT, and SIT test steps shall have been successfully completed.

All the instrument units shall be integrated and health check at instrument level shall have been successfully run.

Constraints related to instruments limited life items and any critical element are specified in AD04.

The skin connectors shall be installed and connected to relevant SCOE as specified in appendix §19.1.

The traffic on the 1553 SDB shall be permanently spied and recorded using the bus monitor of the CDMS SCOE connected to the skin connectors SK02 J01 and J02.

The traffic on the 1553 ACMS Bus shall be permanently spied and recorded using the bus monitor of the ACMS SCOE connected to the skin connectors SK02 J03 and J04.

The umbilical links shall be connected to allow satellite telecommands and permanent telemetry monitoring.

The RF-SCOE shall be connected to satellite through dedicated antenna test caps.

The real FM battery shall be used only when requested (Launch Mode test, "clean run" and Reference Mission Scenario). In the other cases, the battery shall be replaced by the Battery Simulator (BATSIM).

The tests shall be run with the latest HPSDB release valid for the specimen under test.

The necessary On Board Control Procedures shall be developed and validated before the test starts.

As a default configuration except for two sequences, Herschel shall be positioned with the +X axis tilted by 20° from vertical, +Y pointing down, to allow a proper instrument sorption cooler operation.

This baseline means nevertheless that the instrument commissioning sequence (see §5.8.4.5) will be prevented to fully test the SPIRE spectrometer mode while the cryostat is still at 20° position.

## 3.1.2. GSE CONFIGURATION

Herschel satellite shall be installed on the Multi Purpose Trolley (MPT).

The Electrical Ground Support Equipment to be used in the frame of the IST shall include :

- The Control Check-out System, properly loaded with the S/C data base and its terminals,
- The Power SCOE especially comprising the Battery Simulator, the Launch Power Supply and the Solar Array Simulator,
- The TTC SCOE,
- The TM/TC DFE,
- The ACMS SCOE including the Star Tracker UCE,
- The CDMS SCOE, including the 1553 Bus Monitor,
- The Herschel instruments IEGSE and any necessary other instrument EGSE as for activating SPIRE launch lock for example (operation under instrument responsibility, see dedicated §3.2.2).

According need, some cooling accessories (fans) may be requested to keep the SVM panel at correct operating temperature, specifically during long duration or concatenated tests. Applicable requirements are given in RD115.

The following diagram depicts the global considered CCS linked EGSE configuration.



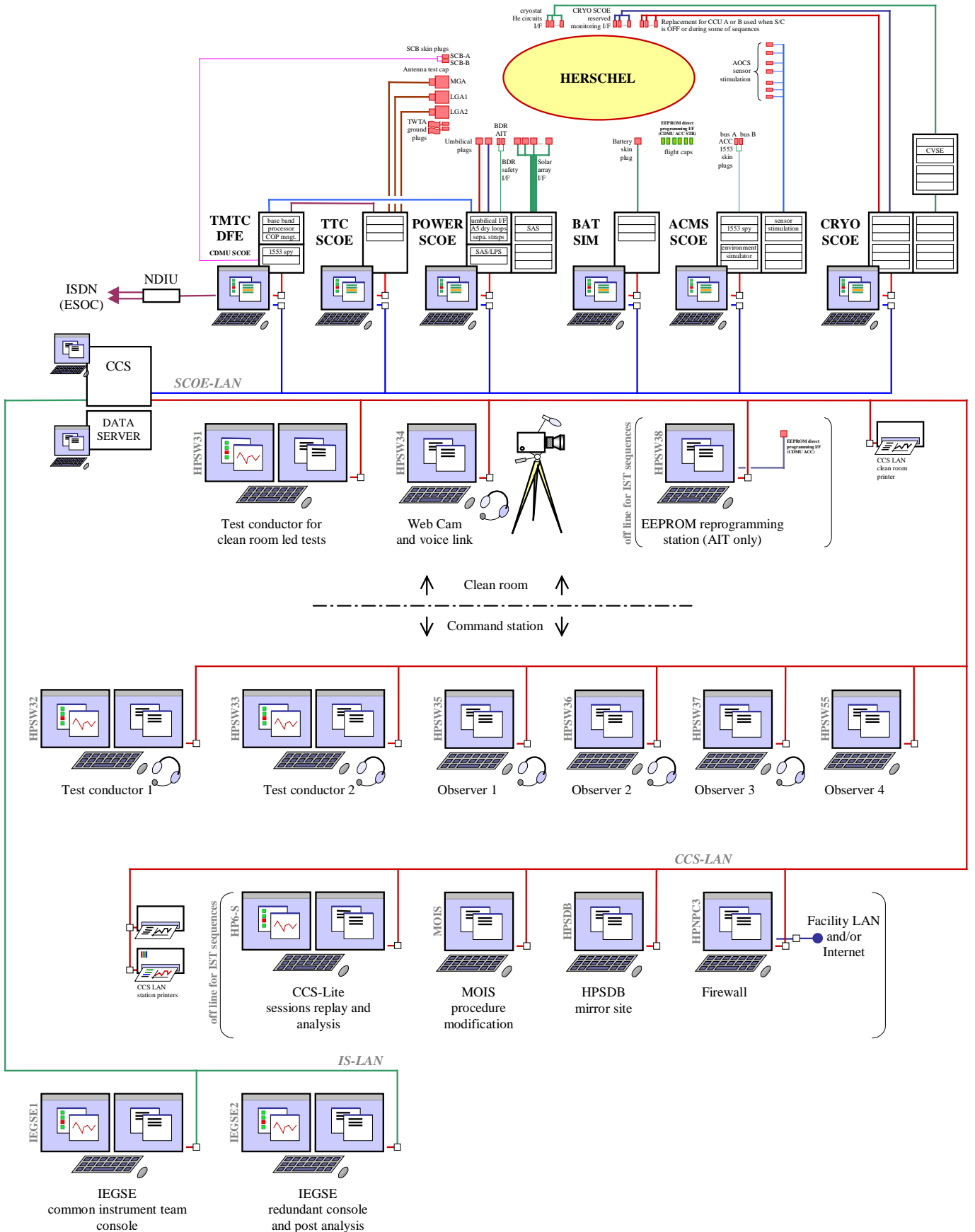

The CCS and TMTC DFE shall be configured by default to up-link TC with normal (that is low) priority (3 most significant bits of sequence counter set to 100b). All TC generated by the CCS will be generated with a low priority setting except for a few cases which will explicitly specified in the test sequences. The high priority TC (3 most significant bits of sequence counter set to 000b) will be used in flight only to go out of a possible lock-out situation. For the IST purpose, they are used only by the test emergency procedures and a few other specific actions.

The Herschel CRYO-SCOE shall be available to monitor and manage the cryostat (specifically to manage the extra cooling effort needed in ambient condition and get the instruments at the right temperature).

### 3.1.3. AVM AND "S/C IST DEBUG" CASES

Before being run on the FM satellite, the IST test sequences shall be run on the AVM or partially integrated FM during the so called "S/C IST debug" campaigns.

Despite not detailed in this document, it shall be understood that the S/C IST debug sequences shall be adapted to cope with AVM built in limitation. As a brief recall:

- open panel layout,
- no redundant units / board (both for platform and instrument) except for the CDMU PM and ACC PM,
- simulated thruster electrical load (RCS),
- simulated heaters and thermal control temperature sensors (TCS),
- single ACMS sample of hardware (1 of 4 RW, 1 STR, 1 CRS, 1 AAD, etc. others being SCOE),
- instrument limited to warm units with simulators for secondary unit and/or FPU units.

The full detailed AVM definition, configuration and limitations shall be found in RD12 (AAS-I AVM technical note) for the SVM related units.

For the 3 instruments, the current reference may be found in each instrument IID-B (RD08, RD09, RD10). But following IST instrument test sequences definition, some dedicated upgrade of the AVM unit is under study to prevent the sequences of being limited by undue false alarms. Specific upgrade are proposed by PACS and possibly by SPIRE, and AVM S/C IST run will include this configuration.

With respect to the IST sequence, the main limitation of AVM is that the cold redundant units are not all present or simulated, then the tests in "all B units" configuration (see definition §5.2) will not be possible, and will be run instead in "all A units" configuration (see definition §5.2). Note: as the CDMS and ACMS PM-B are part of redundant units which are present, then test in "PM B" configuration can be run on AVM.

The appendix 10 (§16) provides an applicability matrix and AVM requirement adjustments which shall be considered for each test sequence.

Warning: the other chapters of this document are written for the context of the ITS1 and IST2 onto PFM S/C (except for a few point explicitly stated). Then, to apply this document to the AVM case, statements need sometime to be transposed.

## 3.2. INSTRUMENTS

The RD106 test specification includes the instrument activities at satellite level during the Herschel S/C PFM IST test programme and defines the required support for two separate situations.

- For the requested test support by Instruments in Spacecraft Verification activities.
- For the requested Spacecraft support during Instrument Specific Performance Tests (SPT's).

The RD106 is called whenever necessary

### 3.2.1. INSTRUMENT CONFIGURATION

#### 3.2.1.1. General configuration requirements

The instruments shall be fully integrated on the satellite and already tested.

For S/C IST test, as for all ground tests, temperature and gravity may endanger the correct instrument operation. This shall be handled by properly orienting the spacecraft axis with respect to local vertical using MPT GSE, and restrict or bias the operation. Specifically:

- The SPIRE FTS (spectrometer mode) operation shall not be activated as part of S/C IST. The spectrometer mechanism (SMEC) shall remain locked.
- The SPIRE sorption cooler (all modes except "OFF", "INIT" and "ON" shall be activated also with "FPU unit on its side", that is satellite X tilted by 20° from vertical with +Y axis pointing down.
- The PACS sorption cooler has the same operation restrictions as SPIRE ones.
- The HIFI LOU has restricted frequency and power ranges when operated at 25°C (default for S/C IST test), which implies specifically that the higher frequency band may not be test (i.e. RD106 test sequence take those limitations into account). Some concerns also apply with respect to unit life time and LOU activation time shall be recorded in the instrument log book (exact procedure are specified by RD106).

Specifically, the instrument performance verification (SPT) shall come with specific constraints. The major technical constraint with SPT (baseline of coupled SPT / S/C IST objectives) is that the cryostat shall be set in He II phase, cover shall be cooled, and the cryostat shall be properly tilted. Other constraints have been taken into account through test programming as reported by RD106, as they concern thermal time constants and the coolers recycling / autonomy duration.

The detailed instrument operation and tests to be run in the frame of the IST are managed through RD106.

#### 3.2.1.2. Instrument FPU launch lock during IST/SPT tests

PACS and SPIRE have launch locks for respectively the PACS grating and the SMEC.

## 3.2.1.2.1. SPIRE SMEC Launch lock

SPIRE SMEC launch lock will be Open only during dedicated tests with the SMEC.

- SPIRE Horizontal SMEC test before and after environment tests

The related test (SPIRE in spectrometer mode) has been removed from the IST scope. Then all S/C IST test shall ensure that the SPIRE launch lock is asserted and no spurious unlock TC can be sent.

## 3.2.1.2.2. PACS Grating launch lock

PACS Grating launch lock has a limited number of OPEN / CLOSE cycles during PACS testing life (about 15 remain for satellite tests).

It shall be closed for any satellite displacement (not including tilt to 20°)

The baseline is that S/C IST and SPT test sequencing (see §3.2.4 below) is optimised to unlock PACS only once. PACS lock shall be:

- OPEN before S/C IST Commissioning,
- Remains unlock through S/C IST Commissioning, SPT, RMS, (i.e. imply no S/C displacement)
- CLOSE at the end of RMS.

The number of OPEN/CLOSE cycles shall be recorded (as for Limited life items).

## 3.2.2. INSTRUMENT IEGSE & GSE

Details are given in RD106.

The instrument "quick look" IEGSE shall be available and connected to the CCS, in a way more or less similar to the one foreseen for the instrument commissioning and performance verification phase.

Complementary GSE, for example, to actuate SPIRE launch lock, shall be available.

## 3.2.3. INSTRUMENT TEAM INVOLVEMENT IN S/C IST TEST

The instrument team will be requested to support the S/C IST with respect to operation procedure design, test success criteria definition and instrument TM post analysis, as well as test real time quick look TM critics.

Details are given in §7.1.1, §8.3.2.2 and RD106.

Instrument team shall provide the procedures (test scripts) needed to operate the instruments.

Delivered test scripts shall conform to RD106 annexe 1 requirements.

### 3.2.4. INSTRUMENT TEST DURING IST AND SPT

#### 3.2.4.1. Instrument tests during IST/SPT:

The following table defines the instrument participation in each of the relevant sections of the IST/SPT, including where relevant the required cryogenic environment.

The table is sorted according to the expected execution sequence, based primarily on the cryo environment needs. It is a requirement from Instruments that the RMS is executed after the SPT's.

ID	Test	Title	Cryo environment	He	S/C orientation
IS-01	IST, S/C	Satellite Commissioning	I	n.a.	n.a.
IS-02	IST, S/C	Instrument FDIR	I	n.a.	n.a.
SS-01	SPT, SPIRE	SPIRE SMEC Functional Test (incl $\mu$ -vibr)	II	He-I	90 deg, +Y up
SP-01	SPT, PACS	PACS Chopper tuning	II	He-I	20 deg
SP-02	SPT, PACS	PACS Grating tuning	II	He-I	20 deg
SH-01	SPT, HIFI	HIFI Diplexer Tuning	II	He-I	0 deg
IS-03	IST, S/C	Mode transitions	II	He-I	n.a.
IS-04	IST, S/C	S/C reconfiguration	II	He-I	n.a.
II-01	IST, HIFI	HIFI Commissioning (perf test + peak up)	III	He-II	n.a.
II-02	IST, SPIRE	SPIRE Commissioning ( CFT + peak up)	III	He-II	20 deg
IS-05	IST, S/C	CDMS Management	IV	He-II	n.a.
IS-06	IST, S/C	DTCP worst case scenario	IV	He-II	n.a.
II-03	IST, PACS	PACS Commissioning (FFT)	IV	He-II	20 deg
SH-02	SPT, HIFI	HIFI SPT	IV	He-II	0 or 20 deg
SP-03	SPT, PACS	PACS SPT	V	He-II	20 deg
SS-02	SPT, SPIRE	SPIRE SPT (incl $\mu$ -vibr)	V	He-II	20 deg
IS-07	IST, S/C + Inst	Reference Mission Scenario	III	He-II	20 deg

Further details of each test shall be found in RD106.

"Cryo environment" code is defined at next §.

### 3.2.4.2. Time Allocation for instruments tests

The overall time allocated to instruments during the satellite IST/SPT is the following.

	Allocation	type of AIT operation
<b>Commissioning</b>	10h/Instrument	3 shifts, 7d/7
<b>RMS</b>	14h/instrument	3 shifts, 7d/7
<b>SPT</b>	3 days of 2 shifts /Instrument	3 shifts, 7d/7

### 3.3. CRYOSTAT

The CRYO-SCOE shall be used to monitor and control the cryostat, specifically between test sequences.

This additional GSE that ensures proper pumping at N513, N511 and N512 throttle level when testing V501 and V503 valves, shall be used when those valve actuation function is tested (launch sequence and launch clean run).

During ground testing the cryostat cryogenics conditions (IF temperatures, stability and mass flow rates) will not be fully representative of the in-orbit conditions. The following table identify the offered cryogenic environments and the expected interface temperatures during the IST/SPT.

No. :	Used when:	HTT configurations:	He	HTT	PACS	OBA	OBA	TS1	TS2	TS3	CW
				(L-0)	L-0 Evap	(L-1)	(L-2)				
II	Whenever He-II is not mandatory	He-I, HTT venting, >20mg/sec	He-I	4.2	~ 6.5	~ 8	~ 17	50 - 70	120 - 160	190 - 230	~ 293
III	Nominal He-II conditions	He-II, HTT venting, > 20mg/sec	He-II	< 1.9	< 2.3	~ 7	~ 15	~ 75	~ 145	~ 210	~ 293
IV	HIFI performance tests	He-II, HTT closed, shield cooling via HOT or Dewar	He-II	< 1.9	< 2.1	< 2.6	< 6	20 - 25	30-35	50-80	~ 293
V	PACS and SPIRE Photometer performance tests	He-II, HTT closed, shield cooling via HOT or Dewar, cover cooling	He-II	< 1.9	< 2.1	< 2.6	< 6	20 - 25	30-35	50-80	~ 293
VI	SPIRE SMEC functional test (S/C +Y up)	He-I, HTT venting, >20mg/sec	He-I	4.2	~ 6.5	~ 8	~ 17	50 - 70	120 - 160	190 - 230	~ 293

Spacecraft orientation will be restricted such that the Rupture Disc of the HTT will not be immersed in the helium bath.

Spacecraft orientation will be restricted such that SV123 can operate in the gas phase.

# Herschel S/C IST specification

REFERENCE: H-P-2-ASP-SP-0939

DATE: December 20<sup>th</sup> 2007

ISSUE: 6.0

Page : 49

---

The He-II filling level will be below 60% when operating with the S/C horizontally, +YS up.

Additional cooling of the OBA/shields will nominally be performed using an external dewar.

Note : according baseline of coupled SPT / S/C IST objectives, the cryostat shall have been filled with He, and shall be in He-II state when the S/C IST sequence start (see §3.1.1). The related cryostat GSE are so not list, but it is expected that they can be made available to manage any possible contingency.

Detailed procedures are under ASSED control and responsibility.

## 4. TEST FACILITY REQUIREMENTS

IST shall be conducted in standard clean room environment. As a brief recall:

- Cleanliness must be class 100000, Fed Std 209-E,
- Temperature shall be controlled in the range 22°C +/-3°C,
- Relative Humidity shall be controlled in the [EVTR] range : 50% +/-10%.

All requirements shall be found in the program "Environment and tests requirements" [RD105].



## 5. TEST DEFINITION

### 5.1. GENERAL INTRODUCTION AND DRIVING REQUIREMENTS

#### 5.1.1. *NOMINAL AND DEGRADED CASES (FOREWORD)*

The S/C IST test sequence specification is organised, for historical reason in 2 main chapters:

- the test of the Nominal Cases,
- the test of the Degraded Cases.

The degraded cases chapter addresses the testing the ability of the S/C to be operated either using all "nominal" units or any "nominal and redundant" unit configuration.

By S/C design, the unit allocation as nominal or redundant, is only (in nearly all cases) a matter of initial S/C configuration (SW tables and relays). To not add dedicated tests, the S/C IST approach is to rotate the unit allocation as nominal or redundant (or their position in the n/n+1 redundancy cases) from one sequence to the other.

The conclusion, is that the §5.9.1 chapter is not a test sequence in itself, but a test that superposes itself on the existing test sequences of §5.8.

The allocated rotation could have been strictly speaking random as long as a proper coverage of all cases is provided. However, to cut discussion about cases and sub-cases, a direct S/C initialisation specification for each test sequence, given in §5.9.2.

Note : for test debug sessions which would use the AVM S/C (if any), the AVM configurations is only partial, and do not provide all the necessary "unit" redundancy. The 5.9.2 chapter unit usage requirement shall be in those cases, transposed as necessary to use indeed, the AVM available hardware.

## 5.1.2. GLOBAL TEST TIMELINE

The following table gives for reference a projection of the S/C IST timeline (consolidated by early debug for test duration in shifts). It gives for each instrument, its estimated activation time allocation with respect to the strict IST objective. It gives also an overview of the S/C initial configuration to be used in conjunction with §5.9 requirements. The "units" / "PM" allocation code is explained in next paragraph.

Set	Day	PM	Units		§	shifts	HIFI	PACS	SPIRE
1	1	A1	A	Launch sequence	5.8.2	1+	OFF	OFF	OFF (lock)
	2	A1	A [B]	S/C Commissioning	5.8.3	2	OFF	OFF	OFF
	3			Spare					
2	1	A1	A	SPIRE Commissioning	5.8.4.5	2	10h	OFF	OFF
	2	A1	B	PACS Commissioning	5.8.4.6	2	OFF	10h	OFF
	3	B1	A	HIFI Commissioning	5.8.4.7	2	OFF	OFF	10h
	4	B1	B	PARALLEL mode commissioning	5.8.4.8	1+	STBY	5h	5h
	5			Spare					
3	1	A1 [B1]	A	Mode transition	5.8.5	2+	1h	1h	1h
	2	A1 [B1]	B	S/C reconfiguration	5.8.6	2	1h	1h	1h
	3	A1	A	Launch mode robustness	5.8.11	1	OFF	OFF	OFF
				MON mode robustness	5.8.12	1+			
	4			Spare					
	5	A2	A	CDMS management + instrument OBCP	5.8.7 5.8.13	2+	STBY	1h30	3h
	6	B2	B	DTCP worst case + instrument OBCP	5.8.8 5.8.13	2+	3h	1h30	STBY
7			Spare						

# Herschel S/C IST specification

REFERENCE: H-P-2-ASP-SP-0939

DATE: December 20<sup>th</sup> 2007

ISSUE: 6.0

Page : 53

Set	Day	PM	Units		§	shifts	HIFI	PACS	SPIRE
4	1	A1	A	Reference Mission Scenario	5.8.9	8+	16h	16h	16h
	2								
	3								
	4	A1	A	Launch clean run	5.8.10	2	OFF	OFF	OFF (lock)

The above timeline is a projection only, provided as first step input for the test planning management. There is no requirement about the actual test order. The test sequences may also be interleaved with other tests (typically SPT ones), as long as those interleaved tests do not alter the S/C state.

It is left to AIT engineering level, the task to optimise the final planning, taking into account the constrain son all the ressources, margns and specifically the management of the cryostat He 1, He 2 state. The requirement for each sequence is defined in this respect in §5.4.7.2.

Some flexibility shall remain. Condition for flexibility is only the respect of each test sequence individual contrans as detailed in this specification chapters.

The above projected 20 day schedule corresponds to IST1. The test timeslots listed above are given without margin (i.e. corresponds to flaw less runs). Three spare days and two shifts are allocated nevertheless to cope with some contingency for IST1. For IST2, the larger experience with procedures are expected to allow this schedule shrinking to fit into 16 days only.

The "units" / "PM" is explained in next paragraph.

## 5.1.3. *NOMINAL AND REDUNDANT HARDWARE TESTING*

For validating redundancy health, the baseline is to alternate the configurations so that all the units have been used once during the S/C IST, without repeating any test (except during commissioning). In a first summary, 4 main configurations are considered:

- "all A" configuration (nominal cases)
- "all B" units on "A" computers (CDMU and ACC PM),
- "all A" units on "B" computers (CDMU and ACC PM),
- "all B" configuration.

The exact picture is more complex as the above simplified view, only outline the complexity of validating all the configurations for the  $n/n+1$  redundancy cases, and all the 1553 BC / bus / RT cases.

The detailed applicable requirements are given in §5.9.

The alternative configuration testing shall validate that all the A/B units are ready and usable indifferently for satellite operation. The goal shall be to activate and to use each hardware once. The goal is not in turn to test exhaustively all possible degraded configuration cases, nor all configurations for all operations.

The "units" and "PM" affectation in previous §5.1.2 table gives the starting baseline for the test configuration.

In square brackets, the table indicates when applicable, the other S/C configurations that are experience during the test sequence by design of this one.

Most IST tests shall be run from CDMU and ACC software image 1 (A1 o B1 in timeline table). One sequence (one for PM-A and one for PM-B) shall be nevertheless run with the software image 2 in order to check that it loads correctly (A2 or B2 in timeline table). In addition, the PM A and B EEPROM content shall be dumped as part of S/C IST configuration archiving, and PM A / PM B, image 1 / image 2 softwares shall be checked for being identical as part of post processing. [...] (requirements moved to 5.9.1)

## 5.1.4. TEST CASE FRAME

The test of the Nominal Cases shall be structured around the test of the System Modes described in AD03 (SOFDIR) §2.3.1 and recalled in figure §5.6.2 or appendix 8. The test sequence shall then comprise :

- the test of the Launch Mode,
- the test of the Launcher separation, the transition to Sun Acquisition Mode after separation,
- the early in orbit activities (VMC operations, etc.) up to and including first Orbit Correction Manoeuvre,
- the test of the Nominal Mode: this test shall essentially consist in the execution of the Reference Mission Scenario as discussed and agreed with ESA (see RD02 and RD106),
- the test of the ability to perform as planned for flight, the satellite and instrument commissioning, calibration and performance validation operations,
- the test of all the transitions to and from: Nominal Mode, Earth Acquisition Mode, Sun Acquisition Mode and Survival Mode,
- the test of a sample of the higher system FDIR level 3 and 4 alarms, and some elementary level 1/2 to sample MOT / EAT FDIR related processes. The level 3 and 4 test cases shall include:
  - CMD5 and ACMS isolated level 3 and 4 alarm cases in L2 like configuration,
  - the test of failure cases during launch : 1 CDMU failure + 1 ACC failure,
  - the test of the CDMS 1553 SDB controller failure cases (end to end FDIR test),
  - the test of the ACMS PM 1553 RT failure cases (end to end FDIR test),
  - the end to end test of all the instrument OBCP (CDMU OBCP), for at least one trigger source,
  - a test of launcher separation called "clean run", realised in the full real launch configuration (on battery, all skin plugs –except safe plugs– disconnected).

### Note 1:

The "ability to perform" wording for the commissioning / performance validation phase means that the tests shall be condensed to fit into a very limited time windows with respect to flight time scale. Ground condition will also limit many result significance. The test shall then be accelerated in time and simplified with respect to real commissioning. It shall nevertheless yet validate the future procedures and go through the different sequences to be run, that corresponds to the test of the in flight performance of each individual unit and subsystem.

### Note 2:

The "clean run" test considers a launcher separation simulation in full real launch configuration (on battery, all skin plugs disconnected). This test shall check any spurious (positive) effect of skin plugs. But ACMS SCOE cannot close the loop without the skin plug data. Then, even with a Sun sensor basic (optical) stimulation, the "clean run" will bring rapidly after separation, the ACMS software to face an incoherent situation which would be in flight equivalent to a multiple failure case. The test shall then only check that all the CDMS and ACMS processes engage themselves exactly as in the nominal launch test (no delta) until the lack of coherent attitude feed back stalls the test. The ACMS ASW stall should occur a couple of minutes after separation typically.

## 5.2. MOVED TO 5.1.3

## 5.3. MOVED TO 5.1.4

## 5.4. MERGED IN 5.1.4

## 5.5. TEST CHAINING

It is reminded that no test context saving is implemented at S/C and/or CCSE level. As a consequence, each test sequence shall theoretically start with the satellite in OFF state and shall be completed after the satellite has been returned in OFF state.

Many tests can nevertheless be chained. This may save many test time, specifically by not repeating the time consuming SSMM initialisation. On this topic specifically, if the SSMM is fully initialised (3 banks) from a previous test and a concatenated one is specified for "≥1 bank" only, the 2 other banks shall not be turned OFF. SSMM 1 bank configuration are specified only the purpose of saving about 30 minutes of satellite initialisation.

Note: the test chaining shall include A/B unit / PM switch-over step when necessary to keep sequence configuration allocation in line with table §5.9.

The ACC and CDMU PM recognise nevertheless a special boot condition for power on reset ("cold start") on ground (when separation straps are present). The test chaining shall remember that. For example, if the test is begun from a non OFF state, the SGM content is operational and used (against EPROM default in "cold start" case).

The test start from a satellite OFF condition is mandatory for testing the launch sequence and launch clean run.

5.6. TEST SAFETY, SUCCESS CRITERIA, NOGO AND SEQUENCE RESUMING

5.6.1. TEST SAFETY AND SEQUENCE RESUMING

It shall be possible to abort any test sequence at any moment in a safe way.

After it has been aborted, a test sequence may be resumed by going back to its initial state, through proper transition and configuration commanding. This is through for the §5.8.5 "Mode transitions", §5.8.6 "S/C reconfiguration", §5.8.7 "CDMS management", and §5.8.13 "Instrument FDIR OBCP" for which each sub-sequence is indeed independent, and can be, in case of failure, resumed individually, without replaying the previous ones.

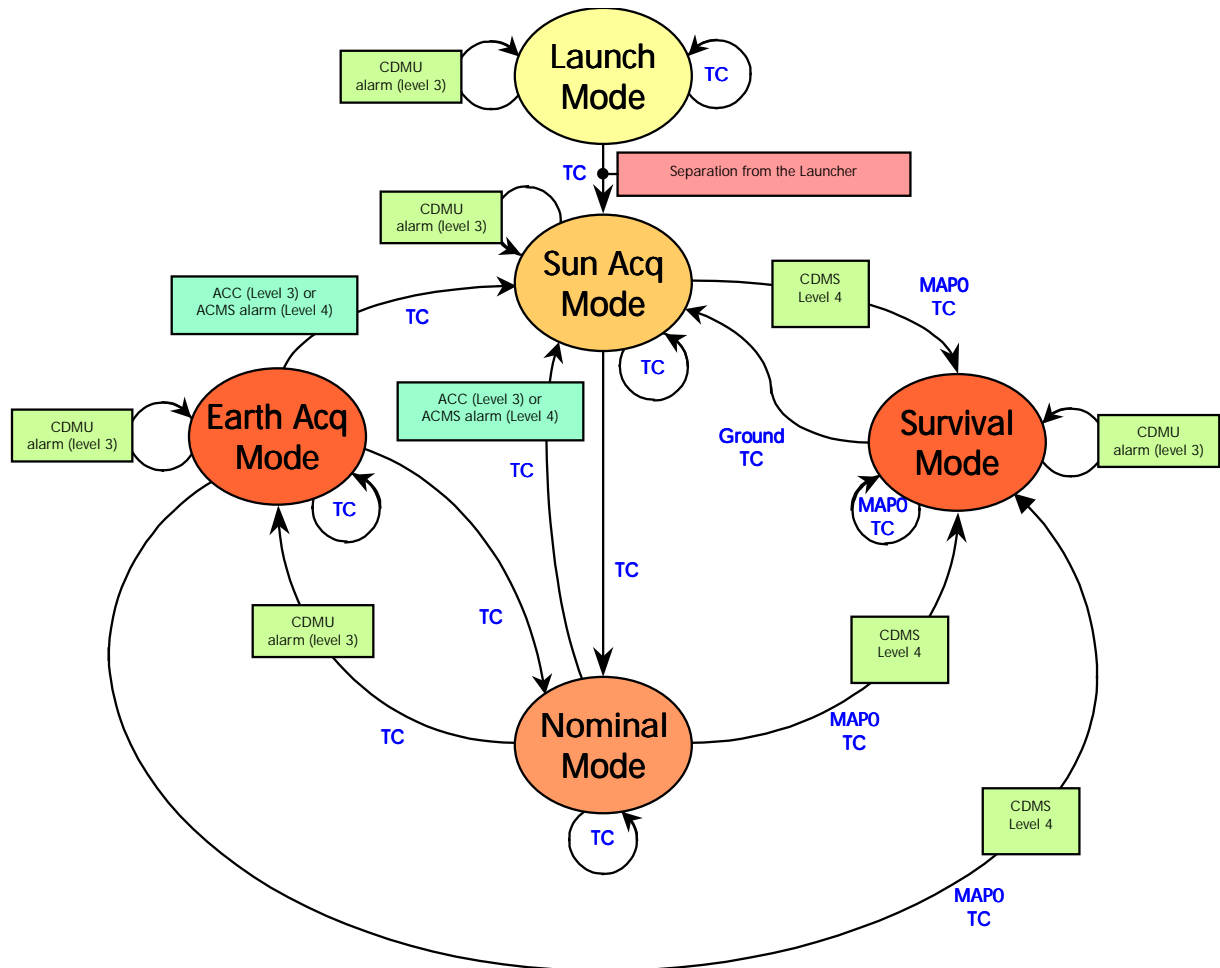

Satellite (CDMS) mode diagram  
(see appendix 8 §16 for more information on CMDMS and ACMS operating modes).

## 5.6.2. *SUCCEES CRITERIA*

This point is detailed in §6, but as an executive summary:

Each test sequence shall be followed by an immediate quick-look post test evaluation from the telemetry.

The checks against the expected values shall be performed first in real time, using the SCOS limit checking facility. This requires that all parameter limits are filled in HPSDB. In most cases, automatic TM retrieve and analysis tools shall be used (analysis of trends, parameter history along the test).

The telemetry acquired through the TM/TC DFE shall be used for real time test control against anomalies (specifically for long test).

Each test success shall be however determined from TM acquired in a flight representative way, as part of post processing. This means that most tests shall end by a TM stores downlink session to recover the available stored telemetry in SSMM. If this telemetry has been already analysed in real time from the umbilical line for test success (that is in a non flight representative way), the test post processing shall at least compare the SSMM stored telemetry with the real time umbilical acquired one for being identical, before concluding to the test success.

During all tests, the instrument correct operation shall be confirmed after analysis of the available TM by instrument representatives.

## 5.6.3. *GO / NO GO CONDITIONS*

This point is detailed in §6, but as an executive summary:

A NO GO condition shall be associated with any parameter being "out of limit". The applicable limits are the values defined by the HPSDB unless otherwise stated in the present specification or associated document (and specifically the relevant user manual).

The "out of limit" general wording includes indeed all the SCOS/CCS automated checking, that is : TM value monitoring against alarm thresholds, dynamic status value checking (consistency check in SCOS 2000 wording), TC pre-validation and post check tests (CEV in SCOS 2000 wording). The "out of limit" covers also the verification of some parameters by the operator as it is requested by some test scripts to allow test to continue.

A NO GO condition shall be associated with any anomaly event report TM(5,2) or TM (5,4) or TC rejection report TM(1,2) or TM(1,8), unless deliberately wanted by the test procedure (test of failure cases, some unit / software initialisation / shut down procedures).

Note: the switching of S/C monitoring source between umbilical and RF will cause unavoidable TM packet loss with respect to real time S/C control by CCS (in SSMM all TM will be present). Some packets may be also lost after their down-linking is disabled as part of the sequence (mode transition or service 14 commands). This may cause false alarms by CCS, specifically with respect to TM packet counter discontinuities. This shall of course not be considered as a NO-GO.



## 5.7. GENERAL TECHNICAL REQUIREMENTS

### 5.7.1. ON BOARD DATA STORAGE

#### 5.7.1.1. SSMM initialisation and shut down requirements

The SSMM formatting shall be as defined in appendix 4 §12.

The applicable bank setting for each sequence is detailed in §5.9.1. (it takes into account the 4 for 3 redundancy case of SSMM bank, and the simplified 1 bank configuration allowed for most sequences to save for configuration time).

The SSMM and packet store initialisation shall be performed as soon as possible after S/C CDMS turn ON, so to provide as early as possible, a TM data safeguard service in case of test incident, this even outside of formal sequences.

In a symmetric way, the last packet store download and the SSMM shut down shall be performed as late as possible in the S/C turn OFF sequence, so to provide as late as possible, a TM data safeguard service in case of test incident.

#### 5.7.1.2. Packet store routine operation requirements

For routine simulated operation at L2, the background MTL shall request a packet store report (for all the stores, and both SSMM) every 10 minutes (flight applicable routine). This feature shall be included in any used "test" MTL.

A packet store report shall be also commanded before and after each SSMM packet store download to cross check information and SSMM pointers values.

Unless specific requirement for the sequence, the routine packet store download shall use the CDMS\_TC(15,7), so a download starts from the ending point of the previous one.

Unless specific requirement for the sequence, the routine packet store download shall consider, in a flight representative way, the downloading only of the data from the SSMM considered "main" (when running a test in "units B" configuration, the "main" could indeed be SSMM-B).

The SSMM considered "redundant" shall be downloaded at the end of the test, as a way -except for RMS sequence- to recover a second back-up of all the test TM data (i.e. except first and last packet of turn ON and turn OFF procedures). The undertaking is that the SSMM packet stores, even in 1 bank configuration, are large enough to cover about 16h of intensive test, so two shift, so all the daily test TM data in a daily organisation as the one projected in §5.1.2. If the test are finally organised differently, the requirement shall be adapted to keep its objective of using the SSMM-B as "overall test sequence TM data back-up". For the RMS the redundant SSMM is affected to an other objective: the testing the circular store cycling, so the requirement is not applicable (i.e. some data stored in "redundant" SSMM will be deliberately overwritten without having been read).

One "SSMM" download operation shall be understood as the requirement to download all the "main" or "redundant" packet stores, so the operation:

- shall include by default, the CEL packet store download, even if, strictly speaking, the CEL is not in SSMM (but SGM).
- shall include by default, the "default" packet store download, even if, by specific S/C IST store definition (see appendix 4 §12), this store shall always be empty.

In any case, care shall be taken at CCS level, that SSMM-A and SSMM-B recovered data are stored in properly separated archive session files (i.e. do not end mixed in a single archive).

### 5.7.1.3. Packets stores, RM logs, CEL and event buffers recovery requirements

At the end of each test sequence, or after any reconfiguration incident (whatever it is part of the sequence, or unsolicited) the different ACMS and CDMS internal TM and event safeguard devices shall also be downloaded for supporting post analysis. This shall include:

- all the packet stores (including default store) of the "main" SSMM,
- all the packet stores (including default store) of the redundant SSMM in the case of an end of sequence,
- the two RM log (RM-A and RM-B) of both the CMDS and the ACMS,
- the two CDMS CEL (SGM-A and SGM-B),
- the two ACMS "Event buffers" (SGM-A and SGM-B). As a matter of precaution, the "passive buffer" shall be read before reading the "actives" ones, so swapping the buffers (see ACMS SW UM RD1 for details).

For the CDMS RM logs, ACMS RM log and ACMS "Event buffers", the download shall be associated with a tool that ensures the decommutation of the raw downloaded data for quick look analysis (i.e. the associated TM packets are not compatible with a "standard" TM packet decommutation, so the requirement is that a work around at script level is implemented, to provide in real time, the test operators and observers with a human readable copy of those safeguarded data).

## 5.7.2. UMBILICAL TM-TC LINK AND RF LINK USAGE

### 5.7.2.1. General requirements

The satellite shall be operated and monitored via the nominal X-band RF link using the antennas caps connections and the RF SCOE, with the following exceptions:

- when the RF downlink is not available because of the simulated satellite context (TWTAs are OFF), the satellite telemetry shall be acquired in real time via the umbilical connections, the uplink being disabled. This kind of operation is also referred as TM "spying".
- during all IST sequences, when the configuration is such that there is a risk of excessive thermal dissipation at the level of the TWTAs, the satellite telemetry shall be acquired via the umbilical connector.
- when simulating activities on the launch pad, the umbilical TM-TC connection shall be used as it will be in actual operation.
- when configuring the S/C out of the actual test sequence, the TM and TC may be acquired in the most convenient way in the context.
- for the §5.8.5 "Mode Transitions" test sequence for which, it is exceptionally allowed to bypass the RF connection, and conduct all the test from the umbilical connection, in a way to save the time of many switch over between RF to Umbilical (note that §5.8.5 indication are written as for full test, i.e. RF / umbilical switch-over when necessary).

By default, as a minimum, during all tests, the power distribution, data handling, TT&C and ACMS functions shall be verified via the available telemetry :

- essential telemetry only for the tests in Launch, Sun Acquisition and Survival Modes,
- essential and all periodic HK for the tests in Nominal Mode, Earth Acquisition Modes.

The TM "spying" shall be done on the basis of the TM available "as is" in the S/C context: it is not permitted specifically to reprogram S/C TM rate, subsampling state, or downlink filter setting to get a better real time observability on the S/C. In case of reduced S/C observability (gap, filter, subsampling), the test result analysis shall be based on differed post analysis of the SSMM stored data.

When simulating the begin / end of contact period between the S/C and the ground, the RF link establishing / closure shall respect the RD118-annex A requirements and more generally ESA PLOP-2 protocol as described in RD36 §4.3. With respect to RD118 defined parameters (sweep and lock characteristics), the SVM UM RD108-§3.9.1 point 10 recommended values shall be preferred. When establishing the up-link, the frequency sweep range may be reduced around the known RX frequency in order to keep the carrier acquisition procedure to an about 2 minute operation.

When simulating a S/C live case, with stabilised 2 way communication between S/C and ground, the link protocol shall be turned to "AD" mode. The BD mode usage shall be reserved to link transient management (as for flight).

The above requirements apply nevertheless only to the actual test sequences. For the test sequence preparatory tasks, and post test check out tasks, the most efficient link in the context shall be used.

# Herschel S/C IST specification

REFERENCE: H-P-2-ASP-SP-0939

DATE: December 20<sup>th</sup> 2007

ISSUE: 6.0

Page : 62

The hereunder table, summarises the applicable stable cases (i.e. out of transients).

Context	TM link	TC link	Comment, example
Simulating launch preparation on ground	<b>umbilical</b>	<b>umbilical</b> (AD mode)	
Simulating launch from TM/TC link switch OFF at Lo-7min, to first TM acquisition by ground	<b>spying</b> (1)	<b>no contact</b> (2,3)	
Simulating a communication phase between the S/C and a Ground station	<b>RF link</b>	<b>RF link</b> (AD mode)	"DTCP" configuration (4)
Simulating a flight phase without communication between the S/C and the ground	<b>spying</b>	<b>no contact</b> (2,3)	"AP" configuration (4)
Preparing the S/C initial configuration for a test sequence	as efficient	as efficient	Switch ON, Accelerated mode setting
Debriefing the S/C after a test sequence	as efficient	as efficient	Final data recovery, Switch OFF,
Sending "spurious" TC for test purpose	as efficient	as efficient	FDIR or alarm case stimulation

(1) for the launch clean run case, the spying stop with actual separation of the umbilical plugs.

(2) care shall taken that DFE sends no signal (including clock) on the umbilical.

(3) care shall taken that TTC SCOE sends no signal (including carrier) on any antenna.

(4) as a generic naming, the corresponding TTC setting will vary according the simulated S/C live case.

As a generic requirements, the TTC-RF operation procedure shall conform to SVM-UM RD108 vol. 3 instructions and recommendation, with a special care for the ones of §3.9.1 "TTC-S operational constraints and warnings".

The attention is also brought on the fact that, when changing the TM rate, the TM encoder setting shall be changed before the XPND one, so that the clock frequency sent by the encoder is already coherent with the new setting, when this one is commanded to the XPND (not in issue 5 of RD108, should be added in issue 6 (XPND NC work around)).

The applied RF signal level for the up-link shall correspond to the following levels (antenna feet level):

Sequence	§	LGA	MGA	Simulated orbital area
Launch sequence Launch clean run Launch mode robustness	5.8.2 5.8.10	-70dbm	-70dbm	LEOP (LGA = Newniorcia, 20000km case) (MGA = LGA)
S/C Commissioning Instrument commissioning	5.8.3 5.8.4	-108dbm	-93dbm	Cruise to L2 (LGA = Vilspa, 350k km case) (MGA = L2)
Mode transitions S/C reconfigurations NOM mode robustness CDMS management DTCP worst case scenario RMS Instrument FDIR OCBP	5.8.5 5.8.6 5.8.12 5.8.7 5.8.8 5.8.9 5.8.13	-122dbm	-93dbm	L2 (LGA1 = Kourou, 1.8M km case) (MGA = Newniorcia, 1.8M km case)

Note : those levels correspond to the "mean" case link budget for the orbital range considered and the "mean" loss between antenna feet and RX level (1.5db for LGA1, 1,35db for MGA) provided by RD39.

## 5.7.2.2. *Simulated DTCP operation, general requirements*

Foreword : the S/C operation is structured as a suite of ground station contact or "Daily TeleCommunication Period" (DTCP) and "Autonomy Period" (AP, satellite operating by its own). The overall set 1 DTCP + 1 AP is called an "Operational Day" (OD). For routine operation at L2, DCTP lasts 3h (quite exactly), and an OD lasts about 24h as a mean (value depends on S/C / ground station visibility and station schedule).

The DTCP simulation for routine L2 operation (RMS, DTCP worst case, CDMS management MTL sequences) shall follow the recommendations of RD107, comforted if necessary by details presented by RD02 and RD06. The generic applicable profile (not considering specific test tasks that may be required for the test), is the following (extract of RD02):

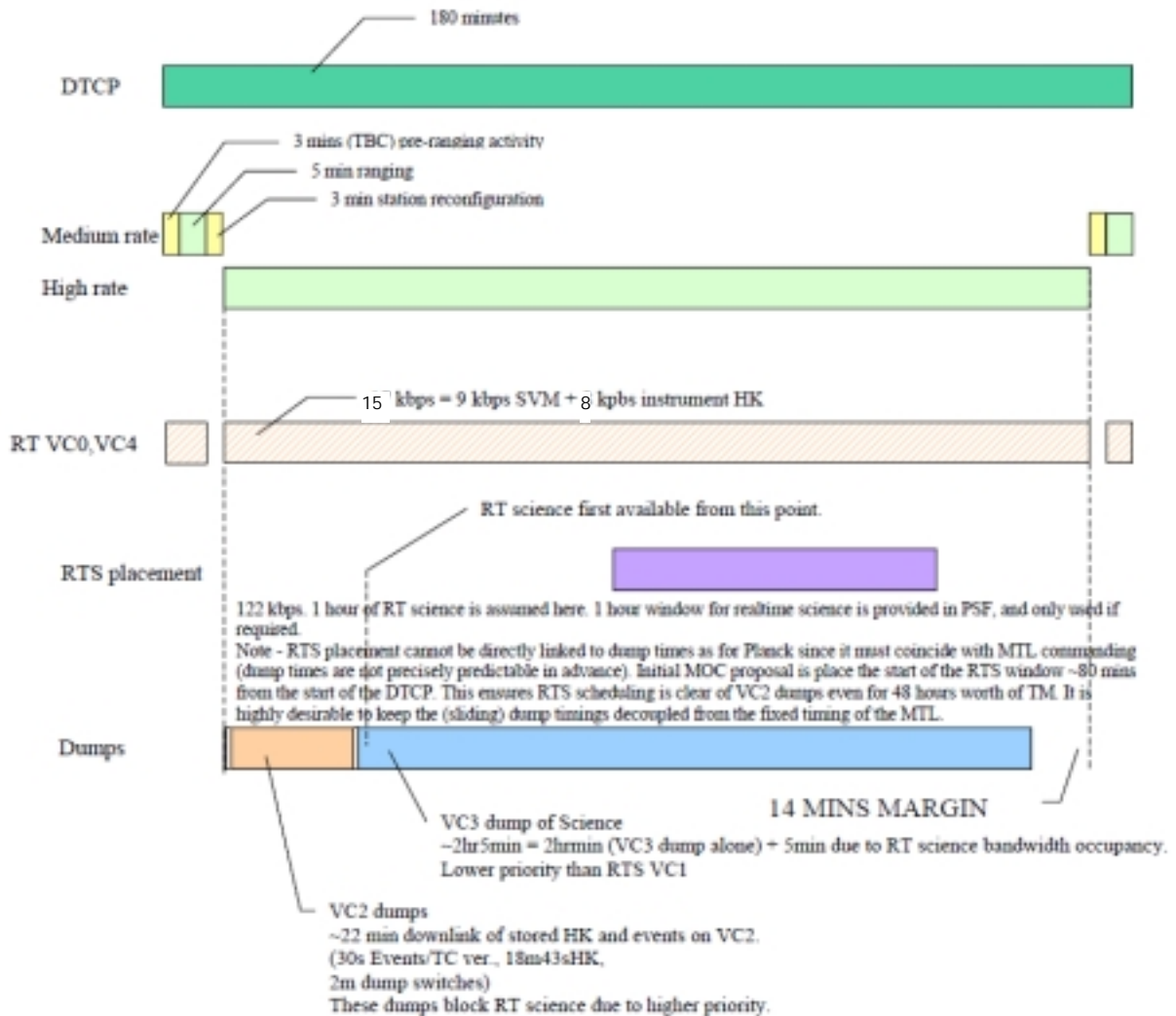

The following diagram presents the different task architecture, taken into consideration the test context, that is that during simulated AP, the S/C is indeed under monitoring by spying its TM from Umbilical IF in conformance to 5.7.2.1 requirements.

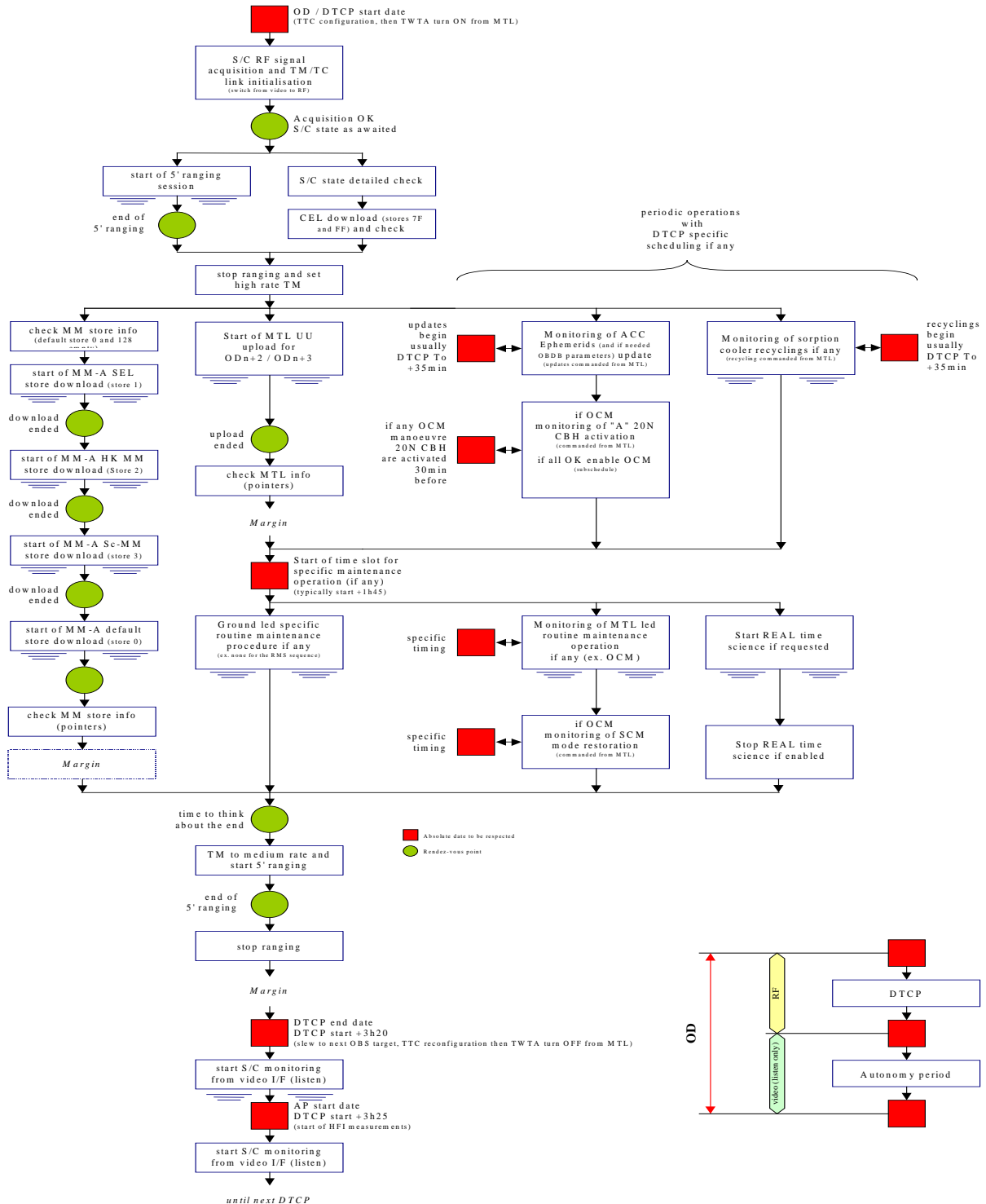

L2 routine Operation Day

### 5.7.2.3. Operation with 500bps 5kbps downlink requirements

When initialising a communication with the S/C at 500bps or 5kbps, among the first operation, the CDMS TM downlink filter CDMS\_TC(14,5) shall be reprogrammed for allowing the downlink of :

- type, subtype (1,1) (1,3) (1,5) (1,7) (1,9)  
(TC acknowledge, (1,2) and (1,8) shall already allowed by default),
- type, subtype (5,1) (event report, (5,2) and (5,4) shall already allowed by default),
- type, subtype (6,6) (memory dump, specifically necessary to get CDMS RM log),
- type, subtype (8,6) (function status report),
- type, subtype (9,8) (9,9) (CRT verification),
- type, subtype (14,4) (14,7) (TM downlink filter ! and TM packet generation state report),
- type, subtype (17,2) (APID pong),
- type, subtype (19,7) (EAT (i.e. FDIR action table) state report).

Note (1) : this shall allow to operate the S/C with an increased commanding and feed back capability.

Note (2) : all those TM are only generated as an answer to a corresponding command, so needed TM bandwidth is a direct function of the send TC.

Note (3) : all those TM are not all necessary, but selected to be of some used in a recovery / anomaly analysis context, and shall be anyway, not generated unless requested. So this filter setting shall not cause any downlink bandwidth problem.

As this setting typically needs several CDMS\_TC(14,5) to be sent, the service 1 shall be set the 1<sup>st</sup> TC in order that a verification capability is provided on the commands that follows. Considering a nominal "launch mode", "SAM", or "SM" CDMS mode default downlink TM filter setting, the first CDMS\_TC(14,5) will fail to return an "acceptance" (or "start") acknowledge, as the corresponding TM(1,1) and TM(1,3) downlink are not yet allowed. The corresponding CCS alarm on acceptance CVS (HPSBD setting for CDMS\_TC(14,5)) shall fail, and this is nominal in this context (i.e. not a no-go). "completion" acknowledge of the first CDMS\_TC(14,5) shall be in turn obtained. All following TC CVS acknowledge verification shall also be successful.

The operation procedure when operating the S/C at the reduced 500bps / 5kbps shall manage the timing between TC to allow a proper recovery of the TM downlink buffer from each asynchronous TM burst to be awaited after each TC. This shall take into account default downlink filter setting (cf. RD26) complemented by the above requirement.



## 5.7.3. GSE PROGRAMMING REQUIREMENTS

### 5.7.3.1. ACMS environment simulation requirements

#### 5.7.3.1.1. Simulation date, ephemerides and orbit propagation

There is no strict requirement about a specific realistic "simulation" date for running the test, except for RMS test and related sequence (§5.8.9, 5.8.7, 5.8.8). Anyone may be used as convenient for the test definition. Specifically, the ACMS SCOE default "simulation" date (January 1<sup>st</sup> 1970) may be used.

However, the March 20<sup>th</sup> 2001 initial date is recommended. Note : it corresponds to a Sun vector just around (1,0,0) in the inertial frame, which will ease post analysis.

For the RMS test, the collaboration with ESOC for synthesising a realistic operation MTL, implies that the ACMS SCOE shall be run with a date and time accurately synchronised with the CCS and S/C ones (within some minutes), and at predetermined simulation starting date and time, typically set in the future.

The (initial) ephemerides and orbit propagation data shall be made coherent with the used simulation date. For the RMS and related sequence (§5.8.9, §5.8.7, §5.8.8), the ephemerides and orbit propagation shall be extracted from the MTL data corresponding to the DTCP which begins the test (§5.8.9 RMS case) or is used as back ground (§5.8.8 DTCP worst case, §5.8.7 CDMS management) (i.e. RMS MTL includes an ephemerides as part of DTCP commands).

#### 5.7.3.1.2. Applicable MCI and Thrust data

MCI TBD

#### 5.7.3.1.3. Alignment and other ACMS perturbation data

There is no requirement about a realistic environment simulation setting with respect to perturbation. The ACMS SCOE may be used with an idealised setting with "no perturbation" (there is in any case, still some simulation noise that keeps the S/C ACMS activity observable).

The "alignment errors" inputs in ACMS SCOE simulation environment (THR, STR, etc.) shall be set to 0.

The "perturbations" inputs in ACMS SCOE simulation environment (perturbing torques) shall be set to 0.

The ACMS OBSW shall be set coherent of those hypothesis if needed (should not be the case).

Note : there is no test objective of simulating a ACMS worst cases through S/C IST test, but rather quite realistic prospective data. The specified settings intends in turn to ease the post analysis.



## 5.7.3.2. ACMS safe state in case of test incident requirements

In case of test incident, if the S/C remains ON (to keep SGM and SSMM data retrievable), the ACMS shall be bring back into "SBM / pre sep" state (mode "stand-by", sub-state "pre-separation"). Note: this implies specifically, that the emergency procedure, closes back the separation straps if they are not in launch configuration, and generates a reset of the ACMS PM.

## 5.7.3.3. CCS programming

In complement to data base and EGSE SW configuration control, CCS "misconfig" files shall be identified as part of the S/C IST test set-up configuration.

- the CDMS and ACMS 1553 bus monitoring GSE shall be connected to the satellite skin plugs and ready to record all bus traffic, (all test, except clean run)

the ACMS SCOE shall be connected to ACMS sensor stimulation inputs and ready for close loop simulation.

## 5.7.3.4. POWER SCOE programming

The POWER SCOE SAS when activated shall be set to simulate the available SA power, according to the test, to one of 3 possible S/C attitude: 1700W (full exposition), 1475W (worst case exposition), 580W (marginal exposition on the launcher after fairing jettison) (i.e. 2A, 1,7A and 0,7A per section typically).

For launch LPS configuration, or SAS configurations with 6 sections (which simulates an LPS operation), the section courant shall be set to  $isc=2A$ .

## 5.7.4. CRYOSTAT RELATED OPERATION

### 5.7.4.1. CRYOSTAT state according sequence

The following table defines the applicable requirements for each test sequence with respect to the CRYOSTAT He II state and S/C tilt need.

Sequence	§	Cryostat state (preferred if available)	S/C position (preferred if available)
Launch sequence	5.8.2	don't care	don't care
S/C Commissioning	5.8.3	don't care	don't care
Spare			
SPIRE Commissioning	5.8.4.5	He II	20° tilt
PACS Commissioning	5.8.4.6	He II	20° tilt
HIFI Commissioning	5.8.4.7	He II	20° tilt
PARALLEL mode commissioning	5.8.4.8	He II	20° tilt
Spare			
Mode transition	5.8.5	don't care (He II)	don't care (20° tilt)
S/C reconfiguration	5.8.6	don't care (He II)	don't care (20° tilt)
Launch mode robustness	5.8.11	don't care	don't care
MON mode robustness	5.8.12	don't care (He II)	don't care (20° tilt)
Spare			
CDMS management + instrument OBCP	5.8.7 + 5.8.13	don't care (He II)	don't care (20° tilt)
DTCP worst case + instrument OBCP	5.8.8 + 5.8.13	don't care (He II)	don't care (20° tilt)
Spare			
Reference Mission Scenario	5.8.9	He II	20° tilt
Launch clean run	5.8.10	don't care	don't care

The tilt angle is given for reference only. The top level requirement is that the tilt shall be optimised to provide both proper sorption coolers operating conditions, and proper cryostat autonomy in the test sequence context. The test sequences may be re-ordered to optimise the cryostat management.

### 5.7.4.2. CRYOSTAT V501, V503, V103, V106 activation by the S/C

For the launch sequence and its derivatives, launch clean run, and launch robustness, the activation of the CRYOSTAT valves V501, V503, V103, V106 are part of the test sequences. The proper setting to prevent a pollution of the CRYOSTAT by this operation shall be set-up, at the time those sequences are run.

For the other sequences, or the debug of the critical launch sequences, the HPLM shall be protected any spurious command on those valves. For that, a physical disconnection of those valves from the CCU circuits may be used.

## 5.7.4.3. CCU usage and CRYOSTAT monitoring constrains

The two CCU (A and B) shall be both connected to the cryostat sensors only for running the launch and RMS test sequences. For those two tests so, all the cryostat monitoring data will be gathered from the S/C TM (and sent back to the CRYOSCOE by CCS).

For all the other sequences, only one of the CCU may be connected to the cryostat sensors, and the other one being connected to dummy line loads, so that one of the sensor set can be permanently controlled by the CRYOSCOE. The disconnected CCU CCS monitoring alarms shall be disabled. Note: this configuration is also applicable to any debug session of the launch and RMS sequence.

The choice of the CCU (A or B) to be disconnected is left to ASED cryostat choice (i.e. always the same to limit the number of connection /disconnection, or alternate configuration to get equilibrated correlation test data from both CCU).

When the S/C is deactivated (OFF) for a long time (several hours, night), the CRYOSCOE shall be reconnected to the two set of sensors.

## *5.7.5. S/C OVERALL CONFIGURATION REQUIREMENTS*

For each test sequence or sub-sequence, the overall S/C configuration shall be complete within the simulated context, even if the configured functionality is not supposed to be activated during the sequence.

Specifically, the following functionality -not set by default-, shall always be properly configured :

- CDMS MTL software service (the MTL buffer shall have be initialised as part of switch ON procedure),
- CDMS OBCP software service (the buffer shall be initialised, OBCP and associated EAT entries loaded as part of switch ON procedure),
- CDMS and ACMS RM survival registers and PAP (they shall be initialised as part of switch ON procedure),
- Whenever the 2<sup>nd</sup> STR is activated, the corresponding Quaternion TM shall be enabled for generation,
- ACMS essential mode telemetry (APID 512) shall be disabled / enabled for generation by ground TC in accordance with activated ACMS mode (it is usually recall in test sequence) but this shall be a routine for ground operated ACMS mode changes, as well as the verification of the proper ACMS non essential (APID 518) mode telemetry autonomous toggling.

Those functions shall be initialised as part of switch ON procedure (in correlation with needed PM / units A/B context defined by §5.9.1), and maintains throughout the test sequences as necessary.

## 5.7.6. FLIGHT BATTERY USAGE REQUIREMENTS

The flight battery shall be used only for running the formal run of 3 sequences:

- §5.8.10 Launch clean run  
(by principle of this sequence (note that DOD data are not representative due to biased timing and SAS unavailability)),
- §5.8.9 Routine Mission Scenario  
(observation of RW power peak smoothing with the real battery behind the BDR).

All the other test sequences, as well as the debugging sessions on PFM for the above ones, shall be run using the battery simulator (BATSIM), in order to limit the number of FM battery cycling to less than 10 for S/C IST need (IST1 IST2 and margin).

Note : more test sequence may be run for debug with a real battery using the AVM model (EQM battery).

## 5.8. NOMINAL CASES

### 5.8.1. TEST SEQUENCES

The S/C IST comprises the test of :

- the launch, separation and early orbit activities,
- the platform commissioning and performance verification activities,
- the instrument commissioning and performance verification activities,
- the basic mode transition with instrument synchronisation,
- the spacecraft reconfiguration (level 3 and level 4 alarms),
- the test of the advanced CDMS management service (not necessarily used by the other tests),
- the test of a worst case DTCP operational scenario,
- the Nominal Mode on a long time scale, based on the Reference Mission Scenario (RMS RD02) for instrument operation,
- the launch "clean run",
- the test of a launch sequence robustness with respect to several vital element failure cases,
- the test of a launch sequence robustness with respect to several severe SCDB failures, implying coupled CMDS / ACMS / Instruments reactions,
- the test of the instrument FDIR related OBCP in an end to end way, implying co-ordinated CDMS / Instrument reactions.

# Herschel S/C IST specification

REFERENCE: H-P-2-ASP-SP-0939

DATE: December 20<sup>th</sup> 2007

ISSUE: 6.0

Page : 71

---

Those 12 sequences are independent, and contain for some even further modularity. Their above listed order is mainly inherited from the document history originally based a certain increasing risk/complexity logic. But they may be run in any order to suit pragmatic constrains (specifically with the RMS sequence that requires more than 48h of continuous operation).

Note : for simplicity, all the test sequences are written considering a nominal flight configuration base, that is an unit / PM non "alternated" configuration. The alternated configuration shall be constructed when applicable, by transposing the sequence elements.

## 5.8.2. LAUNCH PHASE, SEPARATION AND POST SEPARATION ACTIVITIES

### 5.8.2.1. Objective

---

**The objective of this sequence is to test the satellite operation with respect to nominal launch conditions, including the immediate post launch activities until the end of the first OCM.**

---

The sequence covers so different S/C operation sets which are planned to take place over several days. This shall be managed by cutting down the waiting times between the operations as well as the first OCM duration. Those cuts shall ensure nevertheless that the satellite has reached a stable state after one operation set before jumping to the next.

A specific sequence objective is to run the sequence with the real flight battery (formal run) in a worst case timing context, so to correlate the actual reached DOD with budgets (a correction will remain necessary, as after ambient condition of test, the TCS consumption will be minimised).

Note: the telescope decontamination is activated as part of this sequence for configuration exhaustiveness, but this functionality in itself will be tested as part of the spacecraft commissioning sequence.

### 5.8.2.2. Test brief description

The test shall be a time representative repetition of the satellite launch, from satellite initialisation under the fairing, to stable state after separation. The satellite waiting time between S/C initialisation and launch shall be nevertheless compacted (satellite in waiting state). The satellite operation after separation, before and after the first OCM shall be also compacted.

The whole sequence represents up to about 72h of real operation but should be compacted in 12h of test.

Note : this sequence is in direct reference with RMS [RDO2] "§6.1 Launch and Early Orbit Phase (LEOP)".

Note: there is no need for testing this sequence in an "alternated" configuration (the satellite will not be launch with already failed units). In turn, launch mode robustness sequence §5.8.11 simulate dynamic failures along a launch sequence.

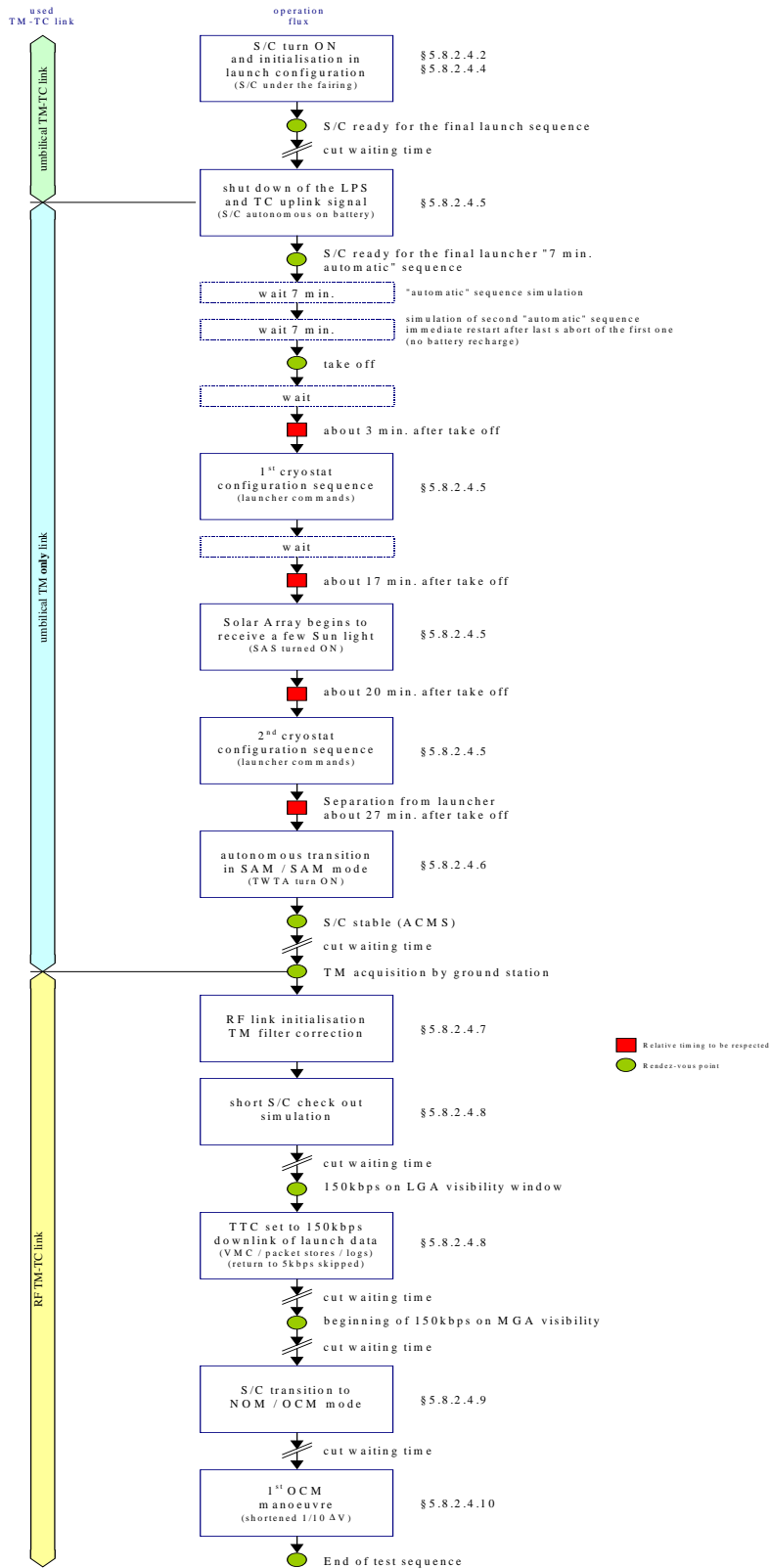

### 5.8.2.3. Initial S/C configuration (before turn ON)

The satellite shall initially be in OFF state, in a “on launcher” representative way (which can imply a short satellite activation to pre-configure it properly). The battery specifically shall be connected, fully charged and both BDR shall be OFF.

Then the configuration shall be set as described in [RD04] “Inhibit Function & Launch and Reconfiguration Sequences” §4.2.2.

The global pre-existing state shall be as in the following figure.

However the more complete applicable view of the S/C on board static relay required state, and skin plug configuration is given in appendix 11 §19.2 and 19.1 respectively.

#### *Satellite state*

CDMS mode	N/A	note:	BDR OFF	ACMS mode	N/A
TM / OBT	A	Rx1 / Rx2 rate	N/A	PM & SW & B	A1N [B1S] N/A
PM & SW	A1N [B1N]	TME / Tx rate	N/A	CRS / FDIR	N/A
SCBP / MTL	N/A	Tx chain	N/A	GYROs	N/A
FDIR / SrvCBH	N/A	Rx 1 Ant.	LGA1	STRs	N/A
launch straps	not separated	Rx 2 Ant.	LGA2	RWs	N/A
PCDU IF / HPS	A / N/A	CCU	N/A	LV	A & B OFF (2)
Battery state	N/A	SPIRE	N/A	THR	N/A
Power domain	N/A	HIFI	N/A	SREM	N/A
Mass Memory	N/A	PACS	N/A	VMC	N/A

#### *GSE support*

Power source	[ SAS-6(1) ]	TM-TC source	[ UMB 4k VCO ]	ENV simulator	stand by
--------------	--------------	--------------	----------------	---------------	----------

Note (1): the POWER SCOE does not allow a safe transition from its LPS configuration to the SAS configuration (off line hardware reconfiguration is necessary). As a work around for running the present launch sequence, the POWER SCOE shall be configured as SAS on the hardware point of view, and the UMB/LPS configuration shall be simulated by activating only the 6 sections of the solar array which are cross-strapped with the umbilical power lines. The result is equivalent with respect to the S/C supply, except that the supplied current does not enter the satellite from the right harness branch. Note: the real LPS configuration is tested during the clean run sequence.

Note (2): as simulated by ENV simulator (real S/C latch valves are never connected during S/C IST).

WARNING : this sequence (formal run) shall be run using the flight battery.

In addition, the exact configuration includes that:



- the battery shall be fully charged (taper at max configurable voltage:  $V_{EOC}$  max), (NB. the BATSIM is not to be used for this test, but may be used for preparatory activations),
- t(see table)(see table)
- the Herschel cryo-cover Safe plug shall be replaced by a test plug that shall provide a dummy load to the command circuit, and detection circuit that will be able to detect any spurious command occurring along the test sequence (as well as safe short circuits on the actuator side).
- (by ACMS SCOE definition)(see table)(see table)antenna test caps shall be connected to RF SCOE and this one shall be ready to receive any S/C emission on LGA1 (no RF up-link),
- (all test, except clean run, moved to §5.7.3)
- (all test, except clean run, moved to §5.7.3)
- the Solar Array Simulator shall be ready to deliver a power limited to 580 Watts (on 30V at S/C IF) by trimming the  $I_{max}$  /  $I_{sc}$  setting to simulate a poor Sun light incidence on the solar panel. All the sections shall be supplied with a similar current. Some modulation is allowed, specifically if it simulate the different section illumination due to Herschel Solar Array shape. But it is forbidden to realised the power limitation by supplying a set of sections at nominal power and shutting down the others. (note: 6 POWER SCOE section supplies are shared with the umbilical power supply (LPS). Then in practice, they will have to be configured later in the test).
- (obsolete)the two CCU (A and B) shall be connected to the cryostat, including the vents valves commands (V501, V503, V103, V106). All cryostat monitoring will be so get through S/C TM for the duration of the test.
- the CVSE shall be connected, in addition to normal pumping interface, to the cryostat exhaust throttles (N511, N512, N513) and shall establish a proper vacuum condition at this level that will prevent any back flow toward the cryostat whenever the related vents valves may open (V501, V503) (i.e. whenever this occurs nominally as part of the test or by fortuitous incident). Proper outlet pressure condition shall be ensured before the other SCOE and S/C power ON and maintained until the S/C is back OFF and LPS SCOE and the TM/TC DFE at least are powered OFF).
- the phase separator valves V103 and V106 shall be closed through CCU-A (a TC(8,4,8,1) shall be used) to simulate the launch conditions (N.B. the hypothesis is that the cryostat is maybe indeed in He II condition for following tests, and that those valves are held open by default).

this may be done as part of preliminary S/C activation. But it is also acceptable to delay this command and insert it as part of the following S/C turn ON sub-sequence (despite less representative), in order to save a dedicated ON OFF S/C sequence for this only purpose.

Note : the sequence does not include the first activation of the instruments. Then there is no need the SPIRE launch lock to be secured (there is no impact on simulated activity). The function will be tested (securing with EGSE, then unlocking by TC) in the frame of the SPIRE commissioning sequence.

## 5.8.2.4. Test steps

### 5.8.2.4.1. General requirements

In the way this specification is written, each step is defined to be run immediately following the previous one. More precisely, the configuration at entry of one step is defined by the configuration at output of the previous step. The conditions at entry of the first step are defined in the "Initial Configuration" above (that is OFF with all latching configuration relays properly set).

Activities are listed in a chronological order. They are numbered in some case to highlight the criticality of the elementary action or check order.

WARNING: The test include the activation of the cryostat venting valves V501 and V503. This activation can generate a catastrophic contamination, if a proper vacuum level is not maintained at the exhaust throttles level to prevent any back flow. This test shall be fully conducted with the service vacuum pump system maintaining the He exhaust throttles (N511, N512 and N513) under vacuum (before test session start until full test session end with satellite and LPS SCOE being off). In addition, the launcher dry loop commands shall not be released without a control that one proper vacuum state is present at the exhaust level and a "go" given by an ASED representative. An emergency procedure shall be available to close back the cryostat valves in case of trouble with maintaining a proper vacuum level at the exhaust throttles level. Despite not flight representative, but to reduce risks, the cryostat valves will be close back in the frame of the "initial check out sequence" step.

## 5.8.2.4.2. *Satellite power ON in "minimum" configuration*

This sequence shall simulate the satellite power ON in "minimum" configuration under the launcher fairing.

For this:

- The TM-TC DFE shall be checked ready for TC uplink at 4kbps in BD mode.
- The satellite shall be turned on by rising up the umbilical power supply simulated by the equivalent 6 SAS sections,
  - > TM emission start shall confirm TRR-A start-up with idle packets at low 1 (500bps) rate (to be checked from TM-TC DFE TM),
- An "unlock" BC frame shall be sent to the two TC decoders (VC0 and VC1), and the two RM shall be disabled, returning on TC decoder A afterward (VC0).
- The two CDMS "cold" PM LCL 31 & 32 shall be commanded ON with a MAP 0 CPDU TC
- The PM-A shall then turn ON with MAP 0 CPDU TC.
  - > TM emission start shall jump to 5kbps (to be checked from TM-TC DFE TM),
  - > essential CDMS Hk TM Packet reception (only, i.e. APID 16 packets only) shall start.
- The CDMS TM downlink filter shall be commanded to allow the TM feed back on TM(1,1) (1,3) and (1,7) packets, or the larger setting as per §5.7.2.3. The CDMS-TC(14,5) acceptance shall be reported missing, but completion successful in this specific context (see §5.7.2.3 for detail).
- The CDMS TM encoder shall be commanded to 150kbps.
  - > The TC acceptance and completion CVS shall be positively verified by the CCS,
  - > TM emission start shall jump to 150kbps (to be checked from TM-TC DFE TM).
- The CDMS TM downlink filter shall be commanded to allow all the TM packet downlink.
  - > non essential CDMS Hk / DIAG TM reception shall start (APID 18).
- The PCDU LCL "CDMU PM A and B cold" shall be confirmed ON by a CDMS-TC(8,4,112,5) PCDU Management service command on LCL 31 & 32, to properly configure the PCDU  $\mu$ ST devices.
  - > Note: this TC acts only in LCL internal logic without any visible status. Only TC(8,4,112,5) shall acquiesce the command.
- Before TCS start delay is over (2.5 min), all the TCS control loops shall be disabled to prevent spurious heater activation at TCS service activation.
  - > at TCS start delay completion, TCS SW service shall transit from "stopped" to "running", but all PCDU HS shall be verified as remaining OFF.
- The two CCU shall be turned ON and initialised in 8s sampling period configuration.
  - > CRYOSTAT TM shall become available, and ASSED specialist shall confirm suitable parameters to go on with the test.

Note : at this step, the most "urgent" are done and the S/C state shall be stable.

- If the CRYOSTAT V101 V106 V501 V503 valves were not positioned in launch like configuration (see 5.8.2.3 on pre-configuration), they shall be properly positioned at this step, under ASSED specialist direction (NB. those valves may be commanded only by CCU command in the used test configuration).
- The CDMU Central Time Reference shall be synchronised with the CCS time (which shall reflect UCT).
  - > TM generation time shall jump from apparent January 1953 (reflecting CDMU CTR time count start from "0") to a dating in line with current time. The alarms upon packet time tag from CCS shall subsequently stop to flow.
- The CEL data from SGM-A and B shall be downlinked to recover the events that have been masked by the downlink filter. Note : the recovered shall appears as 1953 generated packets. Among them:
  - > CMDS-TM(5,1,134) shall be recovered in a double copy (one per CEL) and confirm PM A start-up (BSW boot),  
CMDS-TM(5,1,101,1) shall be recovered in a double copy (one per CEL) and confirm ASW initialisation in launch mode from recognised turn ON situation,
  - > the above CMDS-TM(5,1,xxx) boot messages shall confirm healthy CDMS hardware and due software versions,
  - > CDMS Hk TM shall confirm the following configuration:
    - >> TM OBT A active,
    - >> PM A active,
    - >> Launch straps reported all in a "not separated" state,
    - >> PCDU 1553 I/F A active,
    - >> PCDU BDR 1 and 2 ON (they are reset to ON at PCDU power up),
    - >> PCDU FCL all ON, and supplied current in the nominal range for the units (taken into account configuration, specifically the SSMM off for the two CDMS FCL),
    - >> PCDU LCL "CDMU PM A and B cold" ON, and supplied current in the nominal range,
    - >> PCDU LCL other : all OFF,
    - >> PCDU HPS shall be all ON after boot and before TCS start up,
    - >> after a 6 minute delay from boot, the TCS shall become automatically active, then redundant HCS shall go OFF.
- CDMS RM log data of SGM-A and B shall be dumped, together with the associated CROME register pointers (memory pointer and .
  - > The RM-A log shall contain a single record for the cold start. The RM-B log shall be empty.
- The CDMS TTR A & B (RM) survival registers shall be initialised,  
The overall TRR / RM A & B functional configuration, including the defaults loaded from TRR EEPROM shall be read back and verified.

- 
- > All the RM parameters shall be conform to the PM-A nominal, reconfiguration on PM-B setting.  
i.e. PAP, pointed RM-CCS ("attempt table"), alarm polarity, attempt counters (shall be all at 0 value), survival register, etc (see RD120 for exhaustive list).  
To save test session time, the formal verification of the registers and tables which shall be "constant" loaded from the TRR EEPROM, may be left to post analysis.  
Functional variable shall be in turn well checked, specifically the attempt counters (shall be all 0).
  - The ACMS WD-A and WD-B shall be enabled.  
The ACMS RM-A and RM-B shall be enabled.  
Note: at this step the CDMU PM may be considered as operational in S/C "minimum" configuration.
  - The SSMM A&B shall be turned ON.
    - > In complement to nominal TC CVS acknowledge and TM status feed back,  
the power consumption on CDMS FCL shall be verified as reaching the nominal operational range.
  - The SSMM packet stores shall be initialised in 3 bank configuration (formal run) according the appendix 4 §12 requirements.  
Note: at this step the SSMM ensure a redundant and exhaustive test data recording service.

**Success criteria :**

The TM acquired during the sequence (OOL, TC CVE, operation procedure or present specification verified TM) shall not indicate any No-Go.

No event packet types (5,2) (5,4) or (1,2) (1,8) shall be generated.

The final state shall be:

*Satellite state*

CDMS mode	LAUNCH	note:	BDR enabled	ACMS mode	N/A
TM / OBT	A	Rx1 /Rx2 rate	4kbps	PM & SW & B	A1N [B1S] A
PM & SW	A1N [B1N]	TME / Tx rate	150k / N/A	CRS / FDIR	OFF
SCBP / MTL	A-0 / stopped	Tx chain	OFF	GYROs	OFF
FDIR / SrvCBH	AFS / OFF	Rx 1 Ant.	LGA1	STRs	OFF
launch straps	not separated	Rx 2 Ant.	LGA2	RWs	OFF
PCDU IF / HPS	A / A	CCU	A B ON 8s-Hk	LV	A & B OFF
Battery	VEOC max	SPIRE	OFF	THR	OFF
Power domain	SA < 6 sections	HIFI	OFF	SREM	OFF
Mass Memory	3 banks (1)	PACS	OFF	VMC	OFF

*GSE support*

Power source	SAS-6	TM / TC source	UMB 4k VCO	ENV simulator	stand by
--------------	-------	----------------	------------	---------------	----------

(1) : formal run, for debug 1 bank only may be used. Note: MTL and OBCP buffers are not initialised.

Note: the SSMM initialisation needs about 15min. per bank, which is driving the sub-sequence duration. It may be paralleled as possible with the other operations, specifically the ACMS or TTC initialisation part of next sequence step (and the cost of no SSMM data in case of anomaly). In this case the above table shall considered as a principle with "Mass Memory" in the process of being formatted in "3 banks" configuration...

**5.8.2.4.3. Short unit health check**

DELETED.

## 5.8.2.4.4. Configuration for launch

---

This sequence shall simulate the S/C configuration for launch.

---

### 5.8.2.4.4.1. End of SSMM formatting

- The MTL software service shall be initialised, then stopped.
- The OBCP software service shall be initialised.  
The OBCP and corresponding EAT entries when necessary, shall be loaded and checked.  
Note : after initialisation, the OBCP software service shall then be left "running".
  - > The MTL and OBCP software service initialisation (i.e. first activation) shall be marked with the BSW signalling with TM(5,4) SSMM buffer errors. This is not a NO-GO in the context (cold start condition is not managed, then the SW try first to restart using SSMM buffers (causing the 5,4 event)

### 5.8.2.4.4.2. ACMS turn ON and configuration

- The CRS 1 and 2 shall be turned ON.
  - > essential Hk telemetry shall confirm LCL status change and nominal current consumption.
- The GYRO 1 and 2 LCL shall be turn ON.
  - > essential Hk telemetry shall confirm LCL status change and nominal current consumption.
- The CDMS SIR and CIR shall be verified as being OFF (and set if not).  
The ACC configuration relays state shall be verified (and set if not) to:
  - ACC RM A and B disabled, PM A and B OFF
  - PM-A active, set PM-A for image 1 / Nominal boot, set PM-B for image 1 / Survival boot.
  - > the ACC and SIR CIR relays should be already in this configuration from previous S/C switch OFF.
- The ACC "cold A" and "cold B" LCL shall be turn ON.
  - > essential Hk telemetry shall confirm LCL status change and nominal current consumption.
- The SCBP shall be set to get the ACMS TM as soon as available (i.e. FDIR disabled, pooling start).  
The ACC PM-A shall be turned ON.
  - > the ACMS telemetry shall be become available, first with January 1953 generation dates.
  - > the ACMS Hk TM shall report the ACMS stable on PM-A in SBM / pre-separation.
  - > after some seconds delay, the ACMS TM packet generation dates shall (autonomously) jump to proper current time.
- The SCBP configuration shall be completed, and nominal bus operation restored (i.e. ACC A marked On and Valid, and SCBP FDIR re-enabled).  
ACMS TM verification may then continue.

- > the ACMS-TM(5,1,xxx) boot messages shall confirm healthy ACMS hardware and due software versions.
- > ACMS Hk TM shall confirm the following more detailed configuration:
  - >> all ACMS unit being marked "healthy",
  - >> CRS 1 and 2 (raw) data shall be properly acquired and shall be conform to ACMS SCOE stimulation setting,
  - >> AAD and SAS (raw) data shall be also properly acquired, and shall be conform to ACMS SCOE stimulation setting (in the context this shall correspond to an absence of Sun, so to no signal).
- A time synchronisation verification command CDMS\_TC(9,6) shall be sent to get an accurate measure of ACMS time synchronisation.
  - > an CDMS\_TM(9,8) and ACMS\_TM(9,9) shall be received.
- ACMS RM log data of SGM-A and B shall be downlinked.
  - > The RM-A log and RM-B log shall be empty.
- The ACMS TRR A & B (RM) survival registers shall be initialised, The overall TRR / RM A & B functional configuration, including the defaults loaded from TRR EEPROM shall be read back and verified.
  - > All the RM parameters shall be conform to the PM-A nominal, reconfiguration on PM-B setting. i.e. PAP, pointed RM-CCS ("attempt table"), alarm polarity, attempt counters (shall be all at 0 value), survival register, etc (see RD120 for exhaustive list).  
To save test session time, the formal verification of the registers and tables which shall be "constant" loaded from the TRR EEPROM, may be left to post analysis.  
Functional variable shall be in turn well checked, specifically the attempt counters (shall be all 0).
- The ACMS ARAD-A and B setting shall be installed.
- The ACMS sensor allocation shall be defined using the ACMS "survival configuration" TC, and ACMS "nominal" TC.
- The ACMS RM-A and RM-B shall be then finally enabled.  
Note: at this step the ACMS PM may be considered as operational in S/C "minimum" configuration.
- The ACMS OBDB parameters shall updated as necessary.
- The ACMS "ephemerides data" (in line with ACMS SCOE setting) shall be loaded.
- The overall ACMS OBDB table shall read back and all values checked.
  - > To save the test session time, the actual OBDB detailed check may be left to post analysis.
- The GYRO shall turned ON in nominal configuration (i.e. A B C units through IF 1).
  - > ACMS TM shall confirm proper GYRO configuration and health.



Note: the usage of real GYRO unit forces an initial Earth rate data collection, therefore the data collection first and the Earth rate compensation after (performed by properly setting dedicated Simulation SW parameters) need to be performed at least once (if no anomalous drift changes has occurred). Note that, in principle, the same values collected during the Gyro health check within ACMS SIT sequence could be used for all closed loop tests. The earth rate compensation removes any Earth rate contribution.

To this aim, any possible difference in GYRO or CRS behaviour between 0-g and non 0-g environment, and at different temperature that are considered relevant for the test purpose, shall be taken into account when setting the fictitious drift/noise/random walk/scale factor etc. of those sensors.

- 
- The SAM low rate telemetry generation shall be enabled.
  - > Corresponding TM packet reception shall start.
- The nominal "survival CBH" LCL shall be turn ON (PCDU management service CDMS-TC(8,4,112,3) on LCL 17).
  - > LCL status and current shall confirm proper "survival CBH" supply.

#### 5.8.2.4.4.3. *TCS configuration*

- The TCT table shall be modified and verified if necessary to bias TCS loops and prevent overheating as necessary. RD115 specified settings shall be used as a baseline, but TRR shall confirm the setting, taking into account the exact S/C configuration (specifically its tilt on MGSE that influence SVM internal convection (1)).
- The proper S/C panel venting, as specified by RD115, shall be verified.
- The TCS control loop shall all be re-enabled in conformance with restriction if any specified by RD115. TRR shall confirm the setting, taking into account the exact S/C configuration (specifically its tilt on MGSE that influence SVM internal convection (1)).
  - > The CRS-1 and 2 loop enabling shall be marked by some corresponding heater activations.
  - > All the other heaters shall remains OFF as a result of TCT setting.  
Note: this considers the baseline that except CRS, all the other units are regulated at a temperature lower than ambient. TRR shall confirm the criteria after exact S/C configuration analysis.

Note (1): the baseline is that all the control loops are operational and validated. If for any reason, a loop has not its 3 input thermistors operational (connected and validated), it shall not be enabled. Care shall specifically be taken during debug sessions for which configuration may be quickly changing.

## 5.8.2.4.4.4. *TTC-RF configuration*

- The XPND1 shall be set for 125bps operation.  
The XPND2 shall be confirmed for 4kbps operation.

WARNING : 4kbps should be confirmed for both XPND, so an XPND1 command is a deliberate error with respect to the nominal procedure : but this choice allows to observe the automatic configuration "confirmation" performed by the ASW at separation.

- > 1553 and direct TM shall reflect the command.
- One TTC-RF SW service report shall be requested (CDMS\_TC(8,5,115)).
  - > Report shall be verified coherent of Hk TM data.
- the TWTA A LCL shall be turned ON from the PCS service 112 (but the LCL only),
  - > the downlink TM rate shall be set to MBR 150kbps: 5kbps should be set, but this choice allows to observe the automatic configuration "confirmation" performed by the ASW at separation,
- the RFDN configuration shall be set in all "A" position (XPND RX1 on LGA1, XPND RX2 on LGA2, position). The all "B" should be set, but this choice allows to observe the automatic configuration "confirmation" performed by the ASW at separation. The all A position gives the same result but is not the baseline reference (ref. RD108 SVM user manual volume 3, TTC subsystem).

## 5.8.2.4.4.5. *CDMS tables check*

- The main CDMS tables TCT, EAT, MOT, CCCT, BSW health tables and ASW UIU shall be read back and checked.  
Reports shall be commanded when necessary (i.e. all table except BSW health tables and ASW UIU).

## 5.8.2.4.4.6. *BATTERY / PCDU verification*

The BDR and BCR shall be set-up and checked for flight.

- The BDR1 and 2 input switches shall be turned ON using their HLC command, using a CDMS\_TC(2,1) "BDR 1 ON Nominal - High Level" and "BDR 2 ON Nominal - High Level"
- The BDR1 and 2 LCLs shall be checked ON
- The BDR1 and 2 LCLs shall be ON by default, but a resetting CDMS\_TC(8,4,112,5) "ON" shall be send successively to the 2 of them (line 73, 74) to confirm their proper state.
- The "BDR 1553 Command status" and "BDR ON/OFF status" shall be verified "ON", over-voltage ("OCP") protection "not active".
- The BCR1, 2 and 3 LCLs shall be ON by default, but a resetting CDMS\_TC(8,4,112,3) "OFF" then CDMS\_TC(8,4,112,5) "ON" shall be sent successively on the 3 of them (line 77, 78, 79) to confirm proper state.
- The DNEL and DNEL arming state shall be verified. DNEL shall be "active" (default turn ON) and its arming shall be "not active".
- A pair of TC(8,4,8,1) "activate" then "de-activate" shall be sent through "PCDU RTA" (which shall be the active one) to reset the DNEL (absolutely necessary) and its arming (despite default shall be correct) to ensure their proper state.
- The DNEL and DNEL arming state shall be verified both "not active" after this reset operation.

## 5.8.2.4.4.7. *CDMS and ACMS RM state verification*

The state of the CDMS and ACMS RM alarm inputs shall be checked.

- 2 CDMS\_TC(8,4,109,8) "read alarm status" shall be sent to get a report on RM-A and RM-B input states. (note, TTR service shall be set "running" to allow this TC).
- No alarm shall be reported, except for the "UDV" and "CPU" alarms of the CDMS PM-B which is OFF.
- A CDMS\_TC(8,4,109,2) "Stop TRR management" shall be sent after this sequence, and the TTR SW service shall be checked "stopped".
- 2 ACMS\_TC(8,4,162) "Get RM status" shall be sent to get a report on RM-A and RM-B states.
- No alarm shall be reported, except for the "UDV" and "CPU" alarms of the CDMS PM-B which is OFF.

# Herschel S/C IST specification

REFERENCE: H-P-2-ASP-SP-0939

DATE: December 20<sup>th</sup> 2007

ISSUE: 6.0

Page : 86

## Success criteria :

The essential TM acquired during Launch shall not indicate any No-Go.

No event packet types (5,2) (5,4) (1,2) (1,8) shall be generated.

The spacecraft units status shall be as in RD116, §3 as recalled below, except for the deliberately modified TTC cases (note: the TWTA case needs an update in RD116 to reflect the latest baseline).

The final state shall be:

### Satellite state

CDMS mode	LAUNCH	note:	RFDN all A (1)	ACMS mode	STB presep
TM/OBT	A	Rx1 / Rx2 rate	125 / 4k (1)	PM & SW & B	A1N [B1S] A
PM & SW	A1N [B1N]	TME / Tx rate	150k (2)	CRS / FDIR	1A, 2S / AFS
SCBP / MTL	A-0 / OFF	Tx chain	T.1(RF OFF) A.OFF(LCL ON)	GYROs	A,B,C IF 1
FDIR / SrvCBH	AFS / N only	Rx 1 Ant.	LGA1	STRs	OFF
launch straps	not separated	Rx 2 Ant.	LGA2	RWs	OFF
PCDU IF / HPS	A / all N	CCU	A, B ON 8s-Hk	LV	A & B OFF
Battery	VEOC max	SPIRE	OFF	RCS	OFF
Power domain	SA < 6 sections	HIFI	OFF	SREM	OFF
Mass Memory	3 banks	PACS	OFF	VMC	OFF

### GSE support

Power source	SAS-6	TM / TC source	UMB 4k VCO	ENV simulator	stand by
--------------	-------	----------------	------------	---------------	----------

Note (1): deliberate errors which intend to check separation CDMS ASW re-enforcement commands.

Note (2): yet nominal at this step (configuration), this will become a deliberate errors when not corrected to 5kbps by the last operations before launch.

## 5.8.2.4.5. Launch

The sequence shall simulate the launch phase from power supply switching to battery power (Lo-7min.) to separation (Lo+17min.), just after a first final count down abort (7min. of battery discharge not restored).

For this:

- The launch phase simulation shall be started by switching the power source from umbilical to battery:
  - 1 > umbilical power supply shall be turn down,
  - 2 > essential Hk TM shall confirm power supply switching to BDR1 and 2 (current and MEA).
- The TM encoder and XPND TM rate set back to 5kbps which shall take place at this step shall be deliberately "forgotten", as well as the TM downlink filter parameter restoration.
  - > This choice allows to observe the automatic configuration "confirmation" performed by the ASW at separation on encoder and XPND, and gives an enhance observability on the S/C during the sub-sequence (all TM packet).
- The DFE uplink TC signal shall be shut down (no data, no clock).
  - > The CLCW of both TC decoder shall report the absence of bit lock and RF lock.
- The worst case duration of the launch phase for battery autonomy shall be simulated.
  - > battery state of charge and BDR current shall be specifically monitored for excessive value.
- the ARIANE 5 dry loop commands shall be ARMED only if the ASED cryostat specialists do confirm proper vacuum condition at the He venting outlets (as LPS SCOE related commands are flagged "critical", the CCS will not issue them without an operator confirmation. Note that the "critical" tag is on the SCOE arming command only so that actual command may pass with a correct timing). The flight baseline is:

command #1 to #4 shall be confirmed by Hk TM spying : #1 "ARM V501 (N) & ARM V503 (R)" armed at Lo+3'46", #2 "OPEN V 501 (N) & OPEN V503 (R)" actuated at 3'56", #3 ARM V101 (N) and V 106 (R)" armed at Lo+20'30" and #4 "OPEN V101 (N) & V106 (R)" actuated at 20'40" (timing TBC after STM2 test results).

- > attentive monitoring of the outlet pressure condition shall be maintained all the time the vent valves are open, and an emergency procedure to close the valves in case of trouble shall be ready.
- The Solar Array Simulator shall be turned ON 17mn after Launch phase initialisation (recall: it shall be programmed to deliver 580 Watts only by properly setting the section current).
  - > the BDR shall stop to power (permanently) the satellite (580W shall be enough until separation to supply the satellite, but not enough to allow for battery recharge or cope with the extra power consumption peaks at separation),
  - > the battery State of Charge (SOC) shall not be lower than 70%.
  - > BCR1 2 and 3 may recharge (slowly) the battery despite the reduced current from SAS setting.

Note : the SAS turn ON after 17mn leads to a total 31mn battery autonomy test. But the limited power may lead to further discharge. This shall remain well within the sizing of 50 minutes of autonomy (sized for Planck).

During launch phase, the essential telemetry shall be acquired in real time via the umbilical connector which shall remain installed.

Note: an emergency V501 and V503 closure command sequence shall remain available for a safeguard action at any time, at cryostat responsible request (NB. this sequence shall typically include an emergency UMB up-link reactivation).

### Success criteria

The essential TM acquired during Launch shall not indicate any No-Go.

No event packet types (5,2) (5,4) (1,2) (1,8) shall be generated.

The spacecraft units status shall be as in RD116, §3 as recalled below (except for TTC(TWTA) settings, deliberately biased).

Cryostat vent valves shall have open in due time and shall be still open.

The final state shall be:

### Satellite state

CDMS mode	LAUNCH	note:	RFDN all A (1)	ACMS mode	SBM presep
TM / OBT	A	Rx1 / Rx2 rate	125 / 4k (1)	PM & SW & B	A1N [B1S] A
PM & SW	A1 [B1]	TME / Tx rate	150k (1)	CRS / FDIR	1A, 2S / AFS
SCBP / MTL	A-0 / Stopped	Tx chain	T.1(RF OFF) A.OFF(LCL ON)	GYROs	A,B,C IF 1
FDIR / SrvCBH	AFS / N only	Rx 1 Ant.	LGA1	STRs	OFF
launch straps	not separated	RX 2 Ant.	LGA2	RWs	OFF
PCDU IF / HPS	A / all N	CCU	A, B ON 8s-Hk	LV enable	A & B OFF
Battery	> 70 %SOC	SPIRE	OFF	RCS enable	A & B OFF
Power domain	SA / battery	HIFI	OFF	SREM	OFF
Mass Memory	3 banks	PACS	OFF	VMC	OFF

### GSE support

Power source	SAS 580W	TM / TC source	UMB / none	ENV simulator	stand-by
--------------	----------	----------------	------------	---------------	----------

Note (1): deliberate errors which intend to check separation CDMS ASW re-enforcement commands.

## 5.8.2.4.6. Separation

---

This sequence shall simulate the launcher separation.

---

For this:

- The separation event  $T_{sep}$  shall be simulated by opening the 8 separation switches of the Launch Power Supply
- The ACMS SCOE shall start automatically closed loop attitude simulation (simulated S/C dynamics). The following separation condition shall be simulated:
  - > initial depointing of +Zs axis = 5° with respect to the Sun, and this depointing shall be oriented toward the +Ys as a worst case situation.
  - > longitudinal angular rate = 0.4°/s, and its sign shall be oriented so that it contribute to increase further the depointing from the Sun toward the +Ys axis.
  - > transverse angular rate = 0.6°/s.
    - > details of ACMS activities related to separation and initial Sun acquisition are stated in RD03 §6.1.3.1.6.
- (moved earlier)The Solar Array Simulator shall be programmed to (be able to) deliver 1700Watts 5 minutes after separation switches opening by trimming the section currents (the AOCS shall stabilise the satellite quicker, but this allows to test that all the separation sequence is robust to low power availability).
  - > the battery State of Charge (SOC) shall not be lower than 70%.
  - > in the time span between separation and SAS power increase, it is nominal that battery power is used to complement the spacecraft power supply.

Note: an emergency V501 and V503 closure command sequence shall remain available for a safeguard action at any time, at ASSED cryostat responsible request (NB. this sequence shall possibly include an emergency UMB up-link reactivation in the first part of the sequence).

### Success criteria

- TTC :
  - > the real time TM shall be available at  $T_{sep} + 180s$  on LGA1. This shall be verified passively as a valid 5kbps signal reception at RF SCOE level (RF and demodulation ok).
  - > the TM rate shall be 5kbps (per ASW action).
  - > the TM downlink filter shall be reconfigured to default LAUNCH setting. This shall be verified passively thanks to the disappearance of CDMS ACMS non essential TM (APID 18 and 514).
  - > both TC Rx rate shall be 4kbps (per ASW action).
  - > the RFDN shall remain in the same antenna configuration, but the configuration confirmation shall return the RFDN individual position to "all B" (nominal way to get the wanted configuration).

- CDMS :
  - > SCBP shall be switched to SAM profile 5.
  - > the Visual Monitoring Camera shall be ON (recording, then storing data, waiting for retrieval).
  - > the THR and LV shall be "enabled" (i.e. LCL 45, 46, 47 and 48 shall be ON).
  - > all essential packets shall be available in real time TM via VCO.
  - > > no event packet types (5,2) and (5,4) shall be generated.
  - > no TC rejection packet type (1,2) or (1,8) shall be generated (NB. CDMS generate TC to itself as part of separation SW sequence).
  
- PCS :
  - > the spacecraft shall run on SAS,
  - > the battery State Of Charge shall not go below 70%, the value when turning ON the SAS at 1700W shall be recorded,
  - > the thruster minimum CatBed heating nominal branch (LCL 17) shall be ON (the redundant one (LCL 18) shall be OFF).
  
- ACMS :
  - > a stable sun pointing shall be achieved within 5 minutes after separation,
  - > the AAD Anomaly Detection criterion shall be enabled at expiration of the delay time (300s),
    - >> to test ACMS may temporisation, the AAD and Sun Sensors shall be stimulated as if the Sun would be out of range until 270s after separation (typically, the ADD and Sun Sensors stimulation shall be disabled). Those stimulation delays shall not cause any ARAD or ACMS SW alarm generation or misbehaviour.
  - Note : the Rate Anomaly Detection criterion shall be all enabled 30s after separation but this is not observable.
  - > the attitude shall be monitored for 10 minutes. It shall be Verified that the ACMS limits cycles within the following boundaries:
    - >> satellite maintains the sun direction at less than 5° half cone from Z axis,
    - >> the transient outside the attitude defined above, for more than 5 minutes, is less than 40° from YZ plane, and its projection onto YZ plane is less than 23° from Z,
    - >> S/L rate is kept below 4 degrees/min .
  - > "low rate SAM" telemetry shall be available.
  
- Cryostat :
  - > the separation shall not change the cryostat state, specifically, the valves position shall not be affected by the ARIANE 5 dry loop command disappearance, and the CCU shall remain operated with a 8s sampling period.

The final S/C status shall be:



## Satellite state

CDMS mode	<b>SAM</b>	note:	<b>RFDN all B</b>	ACMS mode	<b>SAM CS</b>
TM / OBT	A	Rx1 / Rx2 rate	<b>4kbps</b>	PM & SW & B	A1N [B1S] A
PM & SW	A1N [B1N]	TME / Tx rate	<b>5kbps</b>	CRS / FDIR	1A, 2S / AFS
SCBP / MTL	A-5 / Stopped	Tx chain	<b>T.1 A.A LGA1</b>	GYROs	A,B,C IF 1
FDIR / SrvCBH	AFS / N only	Rx 1 Ant.	LGA1	STRs	<b>OFF, LCL ON</b>
launch straps	all separated	Rx 2 Ant.	LGA2	RWs	<b>OFF, LCL ON</b>
PCDU IF / HPS	A / all N	CCU	A, B ON 8s-Hk	LV	<b>A ON B OFF</b>
Battery	>70 %SOC CHG	SPIRE	OFF	RCS	<b>A CBH-T ON</b>
Power domain	SA	HIFI	OFF	SREM	OFF
Mass Memory	3 banks	PACS	OFF	VMC	<b>ON images strd</b>

## GSE support

Power source	SAS 1700W	TM / TC source	UMB / none	ENV simulator	<b>closed loop</b>
--------------	-----------	----------------	------------	---------------	--------------------

### 5.8.2.4.7. Post separation

This sequence shall simulate the spacecraft control acquisition by the ground station. This shall occur nominally at Tsep+18min. (on LGA1). The delay may be a few contracted down to Tsep+10min. for the test.

- The DFE TM and TC IF shall be switched to RF link.

All the TC shall be sent through LGA1 (-Z) through the RF SCOE (umbilical shall not be used any more unless for an emergency interruption of the test).

- Ground TC activities shall begin at T<sub>sep</sub>+ 10 to 15min. with the RF link acquisition in conformance with §5.7.2.1 requirements (ESA plop type procedure).

Note: the S/C shall be in AD mode as part of this procedure.

- The TM downlink filter shall be commanded to larger observability as per §5.7.2.3 requirements. A CDMS\_TC(17,1) shall be used before and after the filter configuration as a way to test the launch default separation sequence setting and command effect:
  - > Before new filter setting is commanded, the CDMS\_TC(17,1) shall receive no echo : no TM(17,2), no service 1 TC acknowledge. This is a nominal behaviour in the context and shall not be considered as an anomaly.

- > Before new filter setting is commanded, the CDMS\_TC(17,1) shall be answered by a TM(17,2) and proper TC acknowledging TM(1,x).
- > As part of post analysis, it will be verified as part of post analysis in SSMM data, that the first TC has been actually answered by the CMDS (TM(17,2) and TM(1,x) (i.e. those answer have remained invisible from ground because of TM downlink filter setting).
- The XPND "in use" shall be commanded in Ranging Mode.
- An ACMS command TC\_SET\_RCS\_CONTROL\_MODE = fine shall be sent.

Note: an emergency V501 and V503 closure command sequence shall remain available for a safeguard action at any time, at cryostat responsible request.

## Success criteria

- SAM System Mode (see RD114 Figure 2.3.3) shall be reached.
- TTC chain A shall be ON and TM shall be acquired via RF SCOE from TTC Tx A and TWTA A.
- S/C attitude shall be monitored for 10 minutes after the "fine" command and it shall be checked that the attitude remains in the same boundaries as specified in previous test step. But the S/L rate is reduced and kept below 2 degrees/min.
- All essential TM packets shall be available in real time TM.
- No event packet types (5,2) and (5,4) nor TC rejection (1,2) or (1,8) shall be generated.
- Ranging shall be nominal that is: a correct ranging echo (power, modulation index, etc.) shall be received. The verification shall ensure only that the transponder is properly programmed for ranging operation as a result of TTC initialisation (NB. it is not asked to check the S/C performance nor calibrations with respect to the ranging).
- The spacecraft units status shall be as in RD116, §4.1 and is recalled below.
- The acquired TM packets shall not indicate any No-Go.

The final satellite state shall be:

*Satellite state*

CDMS mode	SAM	note:		ACMS mode	SAM FINE
TM OBT	A	Rx1 / Rx2 rate	4kbps	PM & SW & B	A1N [B1S] A
PM & SW	A1N [B1N]	TME / Tx rate	5kbps + <b>RNG</b>	CRS / FDIR	1A, 2S / AFS
SCBP / MTL	A-5 / OFF	Tx chain	T.1 A.A LGA1	GYROs	A,B,C IF 1 ON
FDIR / SrvCBH	AFS / N only	Rx 1 Ant.	LGA1	STRs	OFF, LCLs ON
launch straps	none	Rx 2 Ant.	LGA2	RWs	OFF, LCLs ON
PCDU IF / HPS	A / all N	CCU	A, B ON 8s-Hk	LV enable	A On B OFF
Battery	> 70 %SOC <b>CHG</b>	SPIRE	OFF	RCS enable	A CBH-T ON
Power Source	SA	HIFI	OFF	SREM	OFF
Mass Memory	3 banks	PACS	OFF	VMC	ON images strd

*GSE support*

Power source	SAS 1700W	TM / TC source	LGA1 VC0	ENV simulator	closed loop
--------------	-----------	----------------	----------	---------------	-------------

**5.8.2.4.8. Initial check out in SAM mode**

This sequence shall simulate the spacecraft initial check out in SAM mode which follows the initial spacecraft acquisition.

Note: the actual sequence shall be completed in flight within about 1 day from separation. The following sequence is so simplified and compacted with respect to full flight representation..

- A TTC service diagnostic TM packet shall be requested with a CDMS-TC(8,5,115) (for test post analysis),
- The TM rate shall be then commanded to medium 150kbps to ease TM downlink (150kbps communication with LGA was not a design requirement, but analysis has shown that it can be supported, and is now considered for early launch operation). In any case, this is helpful to reduce the S/C IST test sequence duration.

Note 1: CDMS mode shall remain SAM. Note 2: Ranging shall be maintained.

- as part of Thermal Control check out, some heater operation threshold shall be adjusted. Within the purpose of S/C IST, this adjustment will be used to trim the TCS power consumption (biased in clean room with respect o flight condition) to a flight representative level.

1 > a TCS command CDMS-TC(8,5,114) shall be sent to get and verify all loops parameters.

- 
- 2 > a TCS commands CDMS-TC(8,4,114,18) shall be sent to shift relevant regulation thresholds to get the wanted power consumption (considering that clean room operation will be stable, the necessary values shall be known before test start).
  - 3 > a TCS command CDMS-TC(8,5,114) shall be sent to read back and verify all loops parameters.
- As part of ACMS check out, the result will be also biased by ground condition, specifically the STR one.
    - > The STR-1 shall be turned ON and checked to confirm that the STR-1 performs nominally and can support the following OCM (STR-1 shall reach the "tracking" mode).
    - > The STR shall be left ON after this test.
  - The telescope heating (first step of decontamination) shall be activated.
    - 1 > the decontamination heating service shall be started by a CDMS-TC(8,1,113).
    - 2 > decontamination heating parameters shall be adjusted if necessary with a CDMS-TC(8,4,113,1) command.
    - 3 > a status report shall be requested with a CDMS-TC(8,5,113) and reported TM(8,6,113) status checked.
  - The VMC data downlink operation shall be run (downlink is in parallel of other operation):
    - 1 > VMC HK packets down-linking shall be enabled by a by adding TM(8,8) packets to TM downlink filter with a CDMS-TC(14,5).
    - 2 > Acquisition of VMC images (TM(8,8)) shall be started by CDMS-TC(8,4,5,1)
    - 3 > The VMC shall be turned off after download of its data is completed and associated packet correctly received through downlink (data are part of VC0). For that, a PCDU unit OFF command CDMS-TC(8,4,112,5) shall be send to the VMC (unit 20).
  - The SREM shall be turn ON and its operation shall be initialised according the 1200s cycle setting of RD114a requirements (plus RD121, RD123, RD114b, RD114c, and RD114d for procedure).
  - The CCU A and B shall be set to the nominal/default 512s sampling period.
  - 
  - A command shall be send from the CRYOSCOE to close the cryostat vent valves V501, V503 (normal CRYOSCOE pumping through V502 remains). Note: V103 and V106 are not concerned and shall remain open.

Note: an emergency V501 and V503 closure command sequence shall remain available for a safeguard action at any time, at cryostat responsible request, until they are nominally closed as part of this sequence.

## Success criteria

No event packet types (5,2) and (5,4) nor specifically TC rejection (1,2) or (1,8) shall be generated.

# Herschel S/C IST specification

REFERENCE: H-P-2-ASP-SP-0939

DATE: December 20<sup>th</sup> 2007

ISSUE: 6.0

Page : 95

Ranging shall continue to be nominal all along the test sequence steps.

The spacecraft units status shall be as in RD116, §4.1 and summarised in table below (outside a specificity for STR, SREM and TM rate).

The acquired TM packets shall not indicate any No-Go. On this point however, many data will be biased with respect to the flight range (TCS specifically) and this shall not be mistaken as No-Go.

The battery shall be recharged at the end of the 1h50' of simulated correct Sun pointing. The end of charge reference is set on the total taper charging current that shall no exceed 1A (C/36) (the 2 BCR shall report a current limiting status). Note: this criteria fulfilment may extend on next sequence to save test time.

The final state shall be:

## Satellite state

CDMS mode	SAM	note:	DEC ON (N2)	ACMS mode	SAM FINE
TM / OBT	A	Rx1 / Rx2 rate	4kbps	PM & SW	A1N [B1S] A
PM & SW	A1N [B1N]	TME / Tx rate	150kbps+RNG	CRS / FDIR	1A, 2S / AFS
SCBP / MTL	A-5 / Stopped	Tx chain	T.1 A.A LGA1	GYROs	A,B,C IF 1
FDIR / SrvCBH	AFS / N only	Rx 1 Ant.	LGA1	STRs (N1)	A ON (LCL B ON)
launch straps	none	RX 2 Ant.	LGA2	RWs	OFF, LCL ON
PCDU IF / HPS	A / all N	CCU	A,B ON HK	LV	A ON B OFF
Battery	> 70 % SOC CHG	SPIRE	OFF	RCS	A CBH-T ON
Power domain	SA	HIFI	OFF	SREM	ON
Mass Memory	3 banks	PACS	OFF	VMC	OFF

N1: this units shall be left ON after their check out to the benefit of their thermal equilibrium and make OCM transition more reliable.

## GSE support

Power source	SAS 1700W	TC source	LGA1 VC0	ENV simulator	closed loop
--------------	-----------	-----------	----------	---------------	-------------

## 5.8.2.4.9. CDMS transition to NOM mode

This sequence shall simulate the satellite transition in NOM mode as part of spacecraft checking and the preparation for the first OCM (about To+2 days for flight).

Note: in flight, the OCM may be held as early as separation + 2 days. The preparation task scheduling is unknown, but the waiting delays shall be condensed anyhow. Then for following S/C IST all the activities are concatenated without any waiting time.

As for real flight operation, the time slot shall be used first to set the satellite in NOM mode and a SSMM download. The transition shall consider the following activities:

- The ACMS "SAM low rate" telemetry shall be turned to "low rate OCM". Then the ACMS shall be commanded into OCM mode with a target corresponding to the SUN with a minor offset to allow an attitude adjustment manoeuvre to be observable. The same vector as entered in VSIR data (ephemerides) may be used.
  - > Attitude shall be verified for 5 minutes with respect to the attitude stability criteria (same as before).
- The ACMS shall be then commanded to target the Earth or an ARAD compatible direction with the ground station being in the MGA field of view. The same vector as entered in VCIR data (ephemerides) may be used.
  - > The SAS power shall be reduced to 1460W to simulate a worst case SA orientation.
  - > Attitude shall be verified for 5 minutes with respect to the attitude stability criteria (same as before).
- All the THR branch A THR CBH shall be turned ON in preparation for the OCM manoeuvre.
- Spacecraft CDMS shall be commanded from Sun Acquisition Mode to Nominal Mode.

This command shall result in the temporary loss of the RF link. This one shall be re-acquired as per §7.5.2.1 requirements. As part of link re-acquisition, Coherent mode, Ranging and AD mode shall be restored.

- > The TTC shall then be set for transmission at the high rate (1.5Mbps), to speed up the next test step.
- When link is re-established, the CMDS FDIR shall be commanded back to AFS.
- CDMS-TC(15,7) shall be sent to enable the Dump of all the packet store of all SSMM A. (implicit by use of 15,7 TC)  
(not a command)
- After download of SSMM is completed, the TTC shall be commanded back to the flight nominal medium rate (150kbps) with ranging.

### Success criteria

No event packet types (5,2) and (5,4) nor specifically TC rejection (1,2) or (1,8) shall be generated.

The spacecraft units status shall be as in RD116, §4.1 and summarised in table below.

The acquired TM packets shall not indicate any No-Go.

# Herschel S/C IST specification

REFERENCE: H-P-2-ASP-SP-0939

DATE: December 20<sup>th</sup> 2007

ISSUE: 6.0

Page : 97

If not already obtained during previous sequence, the battery shall be recharged at the end of the 1h50' of simulated correct Sun pointing. The end of charge reference is set on the total taper charging current that shall no exceed 1A (C/36) (the 2 BCR shall report a current limiting status). The battery shall be fully recharged at separation + 4h (taper charging current that shall no exceed 100mA).

The final state shall be:

## Satellite state

CDMS mode	NOM	note:	DEC ON	ACMS mode	OCM (Earth CS)
TM / OBT	A	Rx1 / Rx2 rate	4kbps	PM & SW	A1N [B1S] A
PM & SW	A1N [B1N]	TM rate	150kbps+RNG	CRS / FDIR	1A, 2S / AFS
SCBP / MTL	A-5 / Stopped	Tx chain	T.1 A.A MGA	GYROs	A,B,C IF 1
FDIR / SrvCBH	AFS / N only	Rx 1 Ant.	MGA	STRs	A ON (LCL B ON)
launch straps	none	RX 2 Ant.	LGA1	RWs	OFF, LCL ON
PCDU IF / HPS	A / all N	CCU	A, B ON Hk	LV enable	A ON B OFF
Battery	100 % soc	SPIRE	OFF	RCS enable	A CBH-A ON
Power Source	SA	HIFI	OFF	SREM	ON
Mass Memory	3 banks	PACS	OFF	VMC	OFF

## GSE support

Power source	SAS 1460W	TM / TC source	MGA VCO	ENV simulator	closed loop
--------------	-----------	----------------	---------	---------------	-------------

## 5.8.2.4.10. Orbit Control Manoeuvre

This sequence shall simulate the preparation and realisation of the first OCM at separation +2 days.

In flight, the OCM preparation sequence itself shall begin at separation +1 days, and last several days. For S/C IST, the operation is chained immediately, with only 5 minutes waiting times left to check attitude stability.

Activities:

- 1• All the OBDB data needed for the OCM manoeuvre shall be up-loaded (ephemeris updates, etc).
- 2• Spacecraft shall be commanded to return on 5kbps telemetry. The TTC RF shall be commanded back the for using LGA1 (and LGA2). This shall include a TWTA switch OFF and back ON. This shall allow in flight perfect observability and commandability for next steps. The procedure shall manage the TM downlink filter of all non-essential TM, the TM rate command, then the TWTA switch OFF and the RFDN command in "blind" mode (TWTA shall be OFF just before) before commanding back the TWTA "in use" ON and performing a signal re-acquisition at the lower rate as per §5.7.2.1. The Ranging shall be re-enabled after the procedure.
- 3• The reaction wheels shall be turned on, RWL diagnostic TM generation enabled, the 4 wheels shall be biased and hold at +19.5Nms (lubrication purpose)
  - > Attitude shall be verified during the wheel speed up and for 5 minutes after with respect to the attitude stability criteria (same as before).
- 4• The ACMS shall be commanded to point for a target corresponding to the delta V orientation, that will be chosen to request a large slew for test purpose.
  - > The SAS power shall be reduced to 1460W to simulate a worst case SA orientation.
  - > Attitude shall be verified for 5 minutes with respect to the attitude stability criteria (same as before).
- 5• The reaction wheels "bias and hold" shall be reduced at +5Nms for RWL 1,2,3 and -5Nms for RWL 4
  - > Attitude shall be verified for 30 minutes (this includes speed down) with respect to the attitude stability criteria (same as before).
- 6• The ACMS shall be commanded (TC\_H-DV) for performing the 16ms Delta V manoeuvre (after RD38). This represent about 1h of thrust (0.8h computed). Book keeping option shall be set ON for this manoeuvre.
  - > Attitude shall be verified for 5 minutes with respect to the attitude stability criteria after the end of thrust (same as before).
- 7• The ACMS shall be commanded to point back for a target corresponding to the ground station.
  - > Attitude shall be verified for 5 minutes with respect to the attitude stability criteria (same as before).
- 8• The reaction wheels "bias and hold" shall be reduced at 500rpm (lubrication)
  - > Attitude shall be verified for 5 minutes with respect to the attitude stability criteria (same as before).
- 9• The TTC RF shall be switch back the for using MGA and medium rate using a NOM mode transition command. This shall include an RF link acquisition as per §7.5.2.1.

To conclude the operation, ranging shall be re-enabled and CDMS FDIR set back to AFS.



10• Details of ACMS activities related to OCM are stated in RD132.

After the manoeuvre completion, ACMS shall be left in OCM pointing\_coarse state.

### Success criteria

The system and subsystems configuration shall be in accordance with the Nominal Mode setting (AD03, figure 2.3.3).

The acquired TM packets shall not indicate any No-Go.

All essential and non essential TM packets shall be available in real time TM.

No event packet types (5,2) and (5,4) nor TC rejection (1,2) or (1,8) shall be generated.

The spacecraft units status shall be as in RD116, §4.3 and summary table below.

The pointing characteristics and performances shall be as stated in RD03 §6.1.3.10.6.

Thruster actuation timing as recorded by ACMS SCOE shall be coherent with commanded slew and  $\Delta V$ .

The final state shall be:

### Satellite state

CDMS mode	NOM	note:	DEC ON	ACMS mode	OCM (POST $\Delta V$ )
TM / OBT	A	Rx1 / Rx2 rate	4kbps	PM & SW & B	A1N [B 1S] A
PM & SW	A1N [B1N]	TME / Tx rate	5kbps + RNG	CRS / FDIR	1A, 2S / AFS
SCBP / MTL	A-5 / Stopped	Tx chain	T.1 A.A MGA	GYROs	A,B,C IF 1
FDIR / SrvCBH	AFS / N only	Rx 1 Ant.	MGA	STRs	A ON (LCL B ON)
launch straps	none	RX 2 Ant.	LGA1	RWs	OFF, LCL ON
PCDU IF / HPS	A / all N	CCU	A, B ON Hk	LV	A ON B OFF
Battery	> 70 %SOC CHG	SPIRE	OFF	RCS	A CBH-A ON
Power Source	SA	HIFI	OFF	SREM	ON
Mass Memory	3 banks	PACS	OFF	VMC	OFF

### GSE support

Power source	SAS 1460W	TM / TC source	MGA VCO	ENV simulator	closed loop
--------------	-----------	----------------	---------	---------------	-------------

## *5.8.2.4.11. End of the sequence*

---

This sequence shall retrieve all SSMM recorded data for post test analysis and experience the packet store clearing in a flight representative way.

---

All board data not yet recovered, shall be downloaded from the S/C as per generic §5.7.1.3 requirements. The TM / TC source may be turned to umbilical connection to ease the post test data retrieval.

### **Success criteria**

All on board stored TM shall be retrieved, and shall be identical to the TM data intercepted thanks to umbilical link monitoring.

The real time TM packets shall not meanwhile indicate any No-Go.

All essential and non essential TM packets shall continue to be available meanwhile download in real time TM.

No event packet types (5,2) and (5,4) nor TC rejection (1,2) or (1,8) shall be generated.

## *5.8.2.5. End of the test*

After sequence completion, the satellite shall be either return to OFF state with standard procedure, or the ON state (with SSMM fully formatted) can be used to chain an other test sequence which do not require to start explicitly from the OFF state.

## 5.8.3. SATELLITE COMMISSIONING

### 5.8.3.1. Objective

---

The objective of this sequence is to run the health check procedure and –as applicable– the performance check procedure of each of the satellite platform subsystems. The sequence shall use –as far as possible–, the actual flight procedures of the satellite commissioning.

---

As part of this test, the correct functioning, in nominal operating mode, of the subsystems and units shall be verified, one by one. Where applicable, the nominal and redundant branches shall be checked.

In more details,

- The verifications are limited to equipment performances potentially affected by the launch. That means, for instance, no test of MTL and OBCP software functions
- For the unit checks, the objective is a functional verification and a verification of SVM subsystem performances in nominal configuration,
  - CDMU, ACC, PCDU, RCS and TCS nominal units as in UIU table
- and of some redundancies as below
  - SAS, CRS, AAD, STR, TT&C nominal and redundant units, nominal and redundant heaters
- For safety reasons, no test of non nominal modes risking to endanger the spacecraft in flight will be performed
- The telescope decontamination is part of the IST commissioning test.
- The preparation of transition from AFS FDIR mode to AFO one which is to be triggered before instruments commissioning

The verification of instruments interfaces are included in instruments commissioning.

System calibrations shall be performed or mimicked (as possible on ground) as part of the commissioning test.

Finally, the commissioning test specified here is derived from [RD139] “commissioning and performance verification plan”. It is consistent with RMS [RD02] “§6.2 Commissioning and Performance Verification Phases”.

### 5.8.3.2. Test brief description

The test is structured as a succession of smaller independent tests at unit and sub-system level.

Each test is rather similar to an UFT or a SIT test except that it is run while simulating in parallel the flight routine :

- the ACMS running in close loop,
- command and data transferred through simulated DTCP sessions,
- and parallel running telescope decontamination procedure (as applicable).

One shall note that long tests could rely on MTL command. Nevertheless, the flight baseline for the commissioning phase is an up to 10h visibility daily, then this shall allow most tests to be run without the MTL.

### 5.8.3.3. Test start configuration

The initial state shall simulate a satellite in a safe configuration for the cruise to L2, that is : in NOM Mode, Earth pointed.

This initial state shall be:

#### *Satellite state*

CDMS mode	NOM	note:	DEC ON	ACMS mode	OCM (PT EARTH)
TM / OBT	A	Rx1 / Rx2 rate	4k/ 125	PM & SW & B	A1N [B1S] A
PM & SW	A1N [B1N]	TME / Tx rate	150kbps +RNG	CRS / FDIR	1A, 2S / AFS
SCBP / MTL	A-1 / stopped	Tx chain	T.1 A.A MGA	GYROs	A,B,C IF 1 ON
FDIR / SrvCBH	AFS / N only	Rx 1 Ant.	MGA	STRs	A (LCL B ON)
launch straps	separated	Rx 2 Ant.	LGA1	RWs	1,2,3,4 ON
PCDU IF / HPS	IF A / all N	CCU	A, B ON HK	LV	A ON B OFF
Battery	CHARGED (BS)	SPIRE	OFF	RCS	A CBH-T ON
Power domain	SA	HIFI	OFF	SREM	OFF
Mass Memory	3 banks (1,2,3)	PACS	OFF	VMC	OFF

#### *GSE support*

Power source	SAS 1475W	TC source	MGA VCO	ENV simulator	closed loop
--------------	-----------	-----------	---------	---------------	-------------

This state may be established either from OFF state by general procedure, or from a previous test sequence through appropriate transitions.

- The satellite pointing target shall be turned to less than 10 degrees from Earth.
- The mass memory shall be formatted so that packet storage is active. 3 banks in each SSMM shall be formatted as indicated in appendix 4. The baseline for commissioning in flight is real time TM observation, but all TM shall be recorded in SSMM to keep a clear copy available in case of incident while running the operations.
- The battery (BATSIM) shall be simulated fully charged. No power shall be requested from the battery by the S/C during this sequence.
- The SAS shall be limited to 1475W power (30° Sun aspect angle, worst case for commissioning).
- The RF link shall be established (use of RF SCOE) with ranging activated.
- The SREM shall be kept OFF until after SVM commissioning.
- The 2 CCU shall be ON.
- The telescope decontamination shall be activated. The ASW task shall be running. The thresholds shall be tricked to limit the heating power (ON time). The decontamination heating drained power profile will be so (as for TCS) not representative of flight worst case.

This sub-sequence is the starting point of the test.

#### 5.8.3.4. TTC commissioning

A number of TTC commissioning activities are actually to be implemented at ground procedures level and have no relevant impact at spacecraft level. The present TTC commissioning tests to be run during IST therefore focuses on the sequences where the spacecraft is particularly involved; this is mainly :

- test of the TTC modes :The following configurations shall be tested one by one. In each case one shall verify the nominal link acquisition.

All the four TM modulations schemes are tested and the absence of Viterbi errors, Reed-Solomon corrections, bad frames and bad packets over 10 minutes for each case, is verified.

The nominal uplink levels shall be applied in each case : -133.5dBm at Rx level at low TC bit rate (125bps) and -120dBm at Rx input at high TC bit rate (4kbps).

The test is performed with TC MI = 1.0 rad pk and RNG MI = 0.7 rad pk (where ranging is present).

For the purpose of this test the uplink TC bitstream shall be composed of service 17 TC's ("ping" TC's).

# Herschel S/C IST specification

REFERENCE: H-P-2-ASP-SP-0939

DATE: December 20<sup>th</sup> 2007

ISSUE: 6.0

Page : 104

Tx chain	TC/TM rates	ranging	Tx Antenna	Rx antenna Rx1 (Rx2)	comments
Tx1/TWTA A	4kbps/150kbps	yes	MGA	MGA (LGA 1)	Initial configuration
Tx1/TWTA A	4kbps/1.5Mbps	no	MGA	MGA (LGA 1)	
Tx1/TWTA A	125bps/5kbps	yes	LGA 1	MGA (LGA 1)	Downlink of non essential TM shall be disabled
Tx1/TWTA A	125bps/500bps	yes	LGA 1	MGA (LGA 1)	Downlink of non essential TM shall be disabled and TM packets filtering shall be active
Tx2/TWTA B	4kbps/150kbps	yes	MGA	LGA 1 (MGA)	redundant configuration
Tx2/TWTA B	4kbps/1.5Mbps	no	MGA	LGA 1 (MGA)	
Tx2/TWTA B	125bps/5kbps	yes	LGA 1	LGA 1 (MGA)	Downlink of non essential TM shall be disabled
Tx2/TWTA B	125bps/500bps	yes	LGA 1	LGA 1 (MGA)	Downlink of non essential TM shall be disabled and TM packets filtering shall be active

At the end of the sequence, the TTC configuration shall be returned to the initial setting :

- Rx1 / Rx 2 rate 4k / 125bps
- TME / Tx rate 150kbps+RNG
- Tx chain Tx1, TWTA1, MGA
- Rx 1 Ant. MGA
- Rx 2 Ant. LGA1

## 5.8.3.5. CDMS commissioning

All periodic, non periodic and diagnostic TM packets shall be enabled to support the CDMS data analysis.

The CDMS commissioning test steps shall be :

- all CDMU memory areas shall be dumped
  - > PM A RAM
  - > PM A PROM, EEPROM (including PM images 1 & 2)
  - > SGM A & B
  - > TTR RAM & EEPROM, Programmable alarm patterns (PAP's)
  - > a limited set of COCOS and CROME ASICs registers (as per flight procedure)
  - > SW tables : Unit in Use table, Monitoring table, Event Action table, Thermal Control table, FCCT
  - > RM log, CEL, SEL

Consistency of each memory area shall be verified.

- Data pool area shall be exhaustively checked by enabling the generation of a specific diagnostic packet
- All MOT entries shall be verified, including ranges and filtering.
- After all entries have been verified to be consistent with MOT settings, CDMS FDIR mode shall be set to AFO
- The 4<sup>th</sup> SSMM bank (bank #3) in each SSMM shall be turned ON and verified using a CDMS\_TC(8,4,2,3). The verification will be limited to the lowest 64ko of the bank #3 memory area to save test time. No anomaly shall be reported during the process, and the TM(8,6,2,3) shall report 0 error. After successful completion of the 4<sup>th</sup> banks formatting, banks #3 shall be turned off in both SSMM A & B.
- The 5 following area shall be dumped in SSMM A and B using the dedicated CDMS\_TC(8,4,2,2) (raw dump).
  - 1 > HwReg, CommBuf and Def area (3 TC starting from 0x00 up to 0x0002.7FFF)
  - 2 > first 124kbyte of the OBCP buffer (2 TC starting from 0x0002.8000)
  - 3 > first 124kbyte of the MTL buffer (2 TC starting from 0x0048.0000)
  - 4 > first 124kbyte of the "Default store" (2 TC starting from 0x0140.8000)
  - 5 > first 124kbyte of the "SEL store" (2 TC starting from 0x0185.FB04)Both SSMM dumps shall be compared and shall be bit to bit identical. Note: a length of 63616 shall be used for each call of the TC(8,4,2,2) to provide the dump for each TC, as a set of 32 TM(8,9,2,2) of uniform (994 bytes) length and ease so the post processing of the packets (note: execution time is about 1 minute per TC).
- OBCP's code shall be dumped and compared with loaded one. After successful cross check, all OBCP's shall be enabled.

## 5.8.3.6. *Moved*

Moved in 5.8.3.4.

## 5.8.3.7. *PCS commissioning*

The PCS commissioning is essentially based on the analysis of the received TM analysis. For S/C IST test, the PCS commissioning is covered by the post analysis of the other sequence results.

One shall NOT verify here the redundant PCDU 1553 interface.

## 5.8.3.8. *CCU (cryostat) commissioning*

All CCU monitoring modes shall be tested (monitoring 1 and monitoring 2), using CCU A then CCU B, which is indeed covered by the use of the two CCU in those 2 modes as part of the other test sequences.

As part of S/C IST, the CCU commissioning sequence shall include only one DLCM sequence led from CCU-A.

## 5.8.3.9. *ACMS commissioning*

The ACMS in flight commissioning comprises both tests which do not request specific procedures, and some dedicated tests :

1. AAD, SAS, CRS, STR, GYR, RCS shall be checked through LEOP SAM and OCM ACMS TM analysis. One shall especially verify the consistency between :
  - a. CRS measurements
  - b. Each CRS and nominal STR measurements
  - c. Each CRS and redundant STR measurements
  - d. CRS and Gyros
  - e. Gyros and STR
2. RWL's health check : the run-in procedure (FCP-H-D-RWLR) shall be applied; the wheels shall be maintained at constant speed using the bias-and-hold loop in OCM. Recommended duration in flight is 32 hours; for the purpose of this test the run in will be limited to 4 hours, and can be performed in parallel with other SFT's : TTC or CDMS.
3. STR functional verification  
STR 2 shall be turned ON.



- a. STR diagnostic packet shall be enabled for STR 1 & 2, and CCD's shall be dumped (this is to extract star location and allow ESOC to derive angular distances).
  - b. Perform the consistency check between STR 1 and STR 2
4. ACC health checks
- all ACC memory areas shall be dumped
  - > PM A RAM
  - > PM A PROM, EEPROM (including PM images 1 & 2)
  - > SGM A & B
  - > TTR RAM & EEPROM, Programmable alarm patterns (PAP's),
  - > ARAD thresholds
  - > a limited set of COCOS and CROME ASICs registers (as per flight procedure)
  - > RM log
- Consistency of each memory area shall be verified
- Data pool area shall be dumped by enabling the generation of a specific diagnostic packet .
5. ACMS dynamic verification
- a. ACMS shall be commanded to SCM
  - b. 2 large slews around (+/-30° around Y) shall be performed (it will be possible, when the S/C is at +/-30° around Y, to evaluate the STR straylight.
  - c. 2 slews of +/- 1° around X shall be performed
  - d. 1 slew around Z at SAA=0° shall be performed. Note that the minimum number of slews to execute a 360° rotation is 3.
  - e. AAD, SAS, CRS, STR, GYR and RWL's measurements shall be analysed for the reached SAA's, and a consistency check between units shall be performed.
  - f. One raster pointing shall be performed
  - g. One line scanning up to the allowed angular domain limit shall be commanded. SSO tracking during the line Scan shall be enabled.
6. Transitions SCM -> OCM -> shall be commanded
7. After successful completion of the above steps (ie. no unexpected events, no ARAD triggering) ACMS FDIR mode shall be set to AFO.

### 5.8.3.10. SREM commissioning

The SREM modes of operation shall be tested according to detailed RD114a requirements:

- §5.2 Start/stop accumulation and data acquisition
- §5.3 Read/set registers

## □ §5.4 Dump/load memory content

The 3 test shall be run in the above defined order.

### 5.8.3.11. TCS commissioning

Most of the TCS in flight commissioning will consist in the analysis of the telemetry returned in the essential, periodic and diagnostic CDMS packets. As such these verifications do not imply specific spacecraft operation and will not be part of the IST commissioning test.

One shall also note that when the test is performed at ambient (IST1 and IST2), some of the Thermal Control Table (TCT) entries (Tmin ON, Tmin OFF, Tmax ON, Tmax OFF) may have to be modified and verified if necessary to bias TCS loops and prevent overheating as necessary. RD115 specified settings shall be used as a baseline, but TRR shall confirm the setting, taking into account the exact S/C configuration.

The following test shall be carried out :

- TCS redundancy check

After the nominal thermal control has been verified to maintain expected temperatures (considering possible changes of the TCT settings), the TCT shall be modified

to enable the redundant control loop indexes (56 to 108)

disable the nominal control loop indexes (2 to 54)

After typically 30mn , it shall be verified that the S/C temperatures are kept identical to the temperatures obtained with the nominal thermal control loops, and that no anomaly is reported (event) by the thermal control function.

The TCT shall be returned in the initial status : enable nominal loops then disable redundant loops.

### 5.8.3.12. Telescope decontamination

This test sequence shall simulate the telescope decontamination procedure.

Note : the test of the decontamination function shall nominally be performed during Thermal Vacuum test. It is however considered necessary to verify, as feasible, the correct operation of the algorithm in the less constraining ambient environment (as far as test conditions and set up are concerned).

The test is twofold:

- verification of the telescope decontamination functionality,
- verification that the procedure can be run in background of the other commissioning activities without interference. It is indeed essential, in flight, to start the decontamination as early as possible Should other SFT's, when run in parallel to decontamination, feature some temporary conflicting / interfering commands toward common elements this shall be managed on a case by case basis. However, considering the telescope thermal time constant, a small decontamination service interruption can be envisaged during the possible conflicting phases. Note that the decontamination process shall be started after completion of the TTC commissioning because the test of the lower bit rates imposes to disable the non essential TM packets, which will be detrimental to the real time observability of the telescope temperatures.

For decontamination functionality test at ambient, the decontamination thresholds shall be commanded to be the following :

- o- low threshold : ambient + 2°C,
- o- high threshold : ambient + 4°C.

The CCS monitoring alarm levels shall be adapted to detect any over-temperature with respect to high threshold, and tolerate some temperature lag under lower threshold.

The above setting shall lead the algorithm to cycle ON and OFF the decontamination heaters. Activation pattern and timing is nevertheless not expected to be representative of flight, and sequence is not expected to be nominal. Test success criteria is limited to obtaining some ON/OFF cycles demonstrating a coherent behaviour via post analysis.

For background runs, the decontamination thresholds shall be commanded to be the following:

- o- low threshold : 14°C,
- o- high threshold : 16°C.

This setting shall lead to never actuate the decontamination heaters. The CCS monitoring alarm levels shall be adapted to detect over-temperature (same threshold as for functionality tests are acceptable) and any HCS activation.

#### Activities :

- 1• Send CDMS-TC(8,1,113) to start the telescope decontamination function. The temperature thresholds shall be adjusted with CDMS-TC(8,4,113,1) to allow the test to be feasible in ambient conditions .
- 2• After 1 hours, send CDMS-TC(8,2,113) to stop the telescope decontamination function.

#### Success criteria

The acquired TM packets shall not indicate any No-Go as applicable du to biased ground condition for temperatures.

All essential and non essential TM packets shall be available in real time TM.

No event packet types (5,2) and (5,4) nor TC rejection (1,2) or (1,8) shall be generated.

Temperatures of the telescope shall be stabilised in the expected range.

### 5.8.3.13. Cryo Cover opening

#### ***This sequence shall simulate the cryo-cover opening sequence***

Although not strictly part of the in-flight commissioning sequence, the test shall be performed in the commissioning test part of the IST. If the PCS commissioning test is logically the best place to run the present sequence, it can be placed at any time during the overall IST commissioning test case.

The nominal opening shall be commanded when HPLM is fully outgassed and telescope temperature is below 70°K, that is about 30 days in the flight (see satellite user manual).

The initial S/C setting for the commissioning test is fully compatible with the execution of this cryo cover opening test.

the Herschel cryo-cover Safe plug shall be replaced by a test plug that shall ensure that:

- 1) the NED command circuit is loaded with an equivalent resistance to the NED and the cryo-cover + CCH harness,
- 2) the NED terminals are shorted and grounded for security (note: there is no safety issue as the actuator is a non explosive device and differential pressure will keep cryostat door closed in case of inadvertent activation. The precaution shall be nevertheless taken),
- 3) an oscilloscope is connected on the dummy NED load terminals to record the NED activation pulse shape (voltage or current as easiest). The oscilloscope trigger shall be allowed before the satellite turn ON to be able to detect any spurious activation, including at PCDU turn ON and turn OFF.

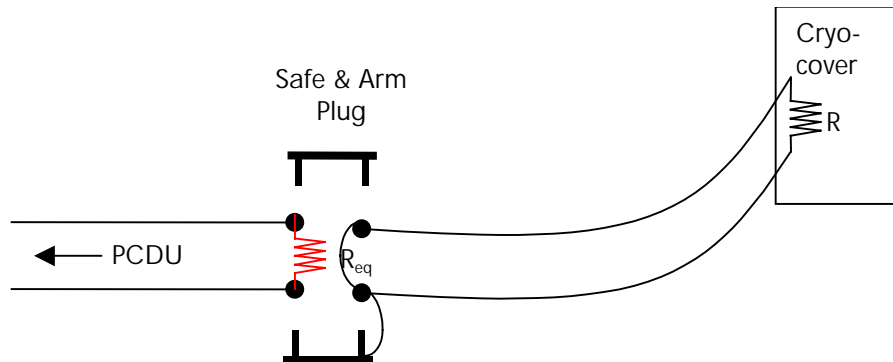

Note: the baseline is that the cryo-cover position sensors are not emulated. Then the telemetry will give a status "failed" to the actuation attempts. Correct NED command pulse detection (at right time) by the oscilloscope device shall be the actual NED activation success criteria.

**Activities :**

- 1• Arm and Fire TC to command the Non Contaminating Actuator shall be sent.
- 2• The current pulse occurrence shall be monitored using an oscilloscope, as shown in Fig. 7.2 at the level of  $R_{eq}$ .

**Success criteria**

The duration and current amplitude of the firing pulse shall be measured and be consistent with RD102 §6.7.13 requirements.

Note: as no EGSE emulate the cryo cover position switches, no feed back in telemetry will assess from a successful opening. This is nominal in the frame of IST.

5.8.3.14. Test end

The test end shall return the satellite in a safe configuration f ready (compatible) for the next step (instruments commissioning), with all FDIR modes set to AFO.

This final state shall be:

*Satellite state*

# Herschel S/C IST specification

REFERENCE: H-P-2-ASP-SP-0939

DATE: December 20<sup>th</sup> 2007

ISSUE: 6.0

Page : 111

CDMS mode	NOM	note:	DEC ON	ACMS mode	SCM (PT EARTH)
TM / OBT	A	Rx1 / Rx2 rate	4k/ 125	PM & SW & B	A1N [B1S] A
PM	A1N [B1N]	TME / Tx rate	150kbps	CRS / FDIR	1A, 2S / AFO
SCBP / MTL	1 / stopped	Tx chain	T.1 A.A MGA	GYROs	A,B,C IF 1 ON
FDIR / SrvCBH	AFO / N only	TRSP 1 Ant.	MGA	STRs	A (LCL B ON)
launch straps	separated	TRSP 2 Ant.	LGA1	RWs	1,2,3,4 ON
PCDU IF / HPS	IF A / all N	CCU	A, B ON Hk	LV	A ON, B OFF
Battery	CHARGED	SPIRE	OFF	RCS	A CBH-T ON
Power domain	SA	HIFI	OFF	SREM	ON
Mass Memory	3 banks (1,2,3)	PACS	OFF	VMC	OFF

## GSE support

Power source	SAS1475W	TC source	MGA	ENV simulator	closed loop
--------------	----------	-----------	-----	---------------	-------------

## 5.8.4. INSTRUMENTS COMMISSIONING AND PERFORMANCE VERIFICATION

### 5.8.4.1. Objective

---

**This sequence shall verify the S/C ability to support the instrument commissioning and performance verification operations.**

---

The "ability to perform" wording means that the limited test time does not allow to simulate the full flight sequence in a fully representative way. Ambient clean room environment comes also with limitations (specifically for HIFI).

The commissioning and performance verification simulation shall be condensed in time to fit a 10h test time slot per instrument.

According to the need, some time slot extension may be granted, but the full instrument commissioning test shall fit in a 1 week time slot (5 x 10h). The condition in which the instrument may possibly remain ON round the clock will have to be refined. Such a need lays typically in the SPT objective and more specifically for checking the two sorption cooler performances.

This sequence is in direct reference with RMS [RD02] "§6.2 Commissioning and Performance Verification Phases" (note nevertheless that telescope decontamination and cryo-cover opening are handled in the S/C commissioning IST sequence).

The following chapter contains only the applicable S/C background configuration that shall be applied for the test, and a summary of the instrument operations. The exact instrument operation requirements are managed by RD106.

### 5.8.4.2. Test brief description

The test shall be structured as a succession of smaller independent tests.

Each test should be rather similar to the instrument UFT except that it shall be run while simulating in parallel the flight routine :

- the ACMS running in close loop.
- command and telemetry transferred through simulated "long" DTCP sessions.

The flight simulation may include that long tests can rely on some MTL commands. The flight baseline for the commissioning phase is nevertheless to perform operation in "visibility" with up to 10h long DTCP.

The baseline for the IST simulation is that the Medium and High rate TM downlink on the MGA is available for the commissioning at any time.

(removed)

(removed, automatic synchronisation).

(TVTB baseline changed)The test shall include a mimic of the instrument line of sight calibration with respect to the ACMS frame. For this, the STR2 will be turned on and configured to run in parallel with STR1, and the ACMS will be configured to provide the diagnostic TM to be used for the calibration (baseline ACMS SIT SAM 01 part 3 procedure).

### 5.8.4.3. Test start (restart) configuration

The initial state shall simulate a satellite in a safe configuration for the cruise to L2, that is : in NOM Mode, Earth pointed, with the TM rate set at 1.5Mbps for maximum observability. All the TM packets shall be allowed for downlink.

The S/C configuration shall be switched from test day to test day in conformance to §5.1.2 table and detailed configurations given in §5.9.2. A summary S/C state table recall the major point for each instrument commissioning sequence. Care shall be taken to the little individual variants that use each configuration to experience all the S/C design cross-straps.

Note : The following satellite S/C table reflects the §5.9.2 tables. Any delta is a typing, and §5.9.2 requirement shall be applied.

In conformance to §5.9.2 requirements, SSMM formatting shall be 1 bank. The instrument test data shall be "real time science" for commissioning (visibility). If the S/C is maintained operational round the clock (sorption cooler verification for example), the formatting may be 3 banks to give more SSMM management flexibility (time lost with formatting will be in turn mitigated by the longer use).

Cryostat state constraints come from SPT. He II is not a need to conduct the test with respect to S/C IST objectives. RD106 §3.5.1 requirements drives the S/C IST ones. Baseline is that He II is used.

- > The correlative baseline is that, to ensure proper cryostat monitoring in any circumstance, one of CCU sensor set shall be connected to the CRYOSCOE (instead of the given CCU). The TM data of the concerned CCU is irrelevant in such circumstances, and shall be ignored (and related alarms disabled). The disconnected CCU shall be alternated from sequence to sequence. The baseline is that the CCU A or B which provide valid data, follow the "unit A or B" allocation for the test.

(5): To save test time, it is possible to start the instrument testing while yet in OCM (Earth) biasing the RW (this is a quite a long operation), so that latest ACMS transition to SCM mode is done in background of the instrument test. Note : RW biasing can be real background task while commissioning.

According He II hypothesis, if the test day includes SPIRE or PACS sorption cooler activation, the S/C shall be moved (if not already done) into the proper S/C axis orientation to ensure a correct operation of those devices under 1g gravity.

In case of test day chaining without S/C shut down, the configuration shall include the avionics configuration switch over at "PM" and "units" level, without instrument shut-down (when they are in stand-by). The "PM" switch over at CDMU PM level shall be managed to not occur while the instrument may be running a background task as sorption cooler recycling (they shall be in STBY).

The SPIRE launch lock shall be set (using dedicated EGSE) before the sequence starts, so that the configuration is representative of SPIRE state after launch (TBC-17 with SPIRE).

- The satellite pointing target shall be Earth, with Earth at the border of the ARAD safe zone (i.e. 30° Sun aspect angle). This pointing may be indeed "toward Earth" only if ENV simulator setting does not allow to generate exactly a 30° Sun – Earth angle. The RWL shall be biased with enough margin to prevent any spurious saturation or 0 crossing during the test day.

- The SAS shall be limited to 1475W power (30° aspect angle), as commissioning attitude may accommodate a worst case Solar Array illumination and good radio link performance.

The SCBP shall be set to the "PRIME" profile for the tested instrument.

The baseline is that the instrument sequence include its turn ON, and ends with its turn OFF.

The OBCP software service shall be checked as being "running" and properly initialised before activating any instrument (initialisation shall be part of routine S/C turn ON, but service may be "stopped" according previous test history).

#### 5.8.4.4. Success criteria

At S/C IST level :

The real time TM packets shall not meanwhile indicate any No-Go.

All essential and non essential TM packets shall be available all long the instrument operation.

No event packet types (5,2) and (5,4) nor TC rejection (1,2) or (1,8) shall be generated.

The above criteria shall be complemented by the analysis of the instrument behaviour by the instrument team. RD106 §5 "Success criteria" defines the applicable criteria, and the §6 "Organisation and responsibilities" defines the specific additive requirement as necessary. Note: the present document §6 "Organisation and responsibilities" includes the general requirements.



## 5.8.4.5. SPIRE commissioning test

### 5.8.4.5.1. SPIRE photometer commissioning test

The background satellite configuration for SPIRE photometer commissioning shall be a "PM A1" "Unit A", as specified in detail in §5.9.2. This may be summarised by the following table:

#### Satellite state

CDMS mode	NOM	note:		ACMS mode	SCM (Earth)
TM / OBT	A	Rx1 Rx2 rate	4k / 125	PM & SW & B	A1N [B1S] A
PM & SW	A1N [B1N]	TME Tx rate	1.5Mbps	CRS / FDIR	1A, 2S / AFO
SCBP / MTL	A-3 / Stopped	Tx chain	T.1 A.A MGA	GYROs	A,B,C IF 1 ON
FDIR / SrvCBH	AFO / N only	Rx 1 Ant.	MGA	STRs	A (LCL B ON)
launch straps	all separated	Rx 2 Ant.	LGA1	RWs	1,2,3,4 ON
PCDU IF / HPS	IF A / all N	CCU	A, [B]* ON Hk	LV	A ON B OFF
Battery	CHARGED	SPIRE	as needed	THR	A CBH-T ON
Power domain	SA	HIFI	OFF	SREM	ON
Mass Memory	(≥) 1 bank (no1)	PACS	OFF	VMC	OFF

#### GSE support

Power source	SAS 1475W	TM / TC source	MGA VCO	ENV simulator	closed loop
--------------	-----------	----------------	---------	---------------	-------------

\* baseline is that the CCU B sensors are connected to the CRYOSCOE to monitor the test. CCU-B shall so be active, but TM is irrelevant and associated alarms shall be disabled.

The detailed program shall conform to RD106 §4.6.3.1 for the photometer tests.

The overall test sequence shall last no more than 10 hours (S/C initial and final configuration is not part of this time allocation).

The 2 other instruments are OFF during this phase.

### 5.8.4.5.2. SPIRE spectrometer complementary commissioning test

Deleted

## 5.8.4.6. PACS commissioning test

The background satellite configuration for SPIRE photometer commissioning shall be a "PM A1" "Unit B", as specified in detail in §5.9.2. This may be summarised by the following table:

### Satellite state

CDMS mode	NOM	note:		ACMS mode	SCM (Earth)
TM / OBT	B	Rx1 Rx2 rate	125 / 4k	PM & SW & B	A1N [B1S] B
PM & SW	A1N [B1N]	TME Tx rate	1.5Mbps	CRS / FDIR	1A, 2S / AFO
SCBP / MTL	B-4 / Stopped	Tx chain	T.2 A.B MGA	GYROs	B,C,D IF 1 ON
FDIR / SrvCBH	AFO / R only	Rx 1 Ant.	MGA	STRs	B (LCL A ON)
launch straps	all separated	Rx 2 Ant.	LGA1	RWs	2,3,4 ON
PCDU IF / HPS	IF B / all R	CCU	A ON, B OFF*	LV	A OFF B ON
Battery	CHARGED	SPIRE	OFF	THR	B CBH-T ON
Power domain	SA	HIFI	OFF	SREM	ON
Mass Memory	(≥) 1 bank (no2)	PACS	as needed	VMC	OFF

### GSE support

Power source	SAS 1475W	TM / TC source	MGA VC1	ENV simulator	closed loop
--------------	-----------	----------------	---------	---------------	-------------

For this specific test the CCU B shall be marked failed and left OFF. Its sensors shall be so the one connected to the CRYOSCOE to monitor the test.

The detailed program shall conform to RD106 §4.6.2.1.

The overall test sequence shall last no more than 10 hours (S/C initial and final configuration is not part of this time allocation).

The 2 other instruments are OFF during this phase.

## 5.8.4.7. *HIFI commissioning test*

The background satellite configuration for SPIRE photometer commissioning shall be a "PM B1" "Unit A", as specified in detail in §5.9.2. This may be summarised by the following table:

### *Satellite state*

CDMS mode	NOM	note:		ACMS mode	SCM (Earth)
TM / OBT	A	Rx1 Rx2 rate	4k / 125	PM & SW & B	B1N [A1S] A
PM & SW	B1N [A1N]	TME Tx rate	1.5Mbps	CRS / FDIR	1A, 2S / AFO
SCBP / MTL	A-2 / Stopped	Tx chain	T.1 A.A MGA	GYROs	A,B,C IF 1 ON
FDIR / SrvCBH	AFO / N only	Rx 1 Ant.	MGA	STRs	A (LCL B ON)
launch straps	all separated	Rx 2 Ant.	LGA1	RWs	1,2,3,4 ON
PCDU IF / HPS	IF A / all N	CCU	A, [B]* ON Hk	LV	A ON B OFF
Battery	CHARGED	SPIRE	OFF	THR	A CBH-T ON
Power domain	SA	HIFI	as needed	SREM	ON
Mass Memory	(≥) 1 bank (no3)	PACS	OFF	VMC	OFF

### *GSE support*

Power source	SAS 1475W	TM / TC source	MGA VCO	ENV simulator	closed loop
--------------	-----------	----------------	---------	---------------	-------------

\* baseline is that the CCU B sensors are connected to the CRYOSCOE to monitor the test. CCU-B shall so be active, but TM is irrelevant and associated alarms shall be disabled.

The detailed program shall conform to RD106§4.6.4.1.

The overall test sequence shall last no more than 10 hours (S/C initial and final configuration is not part of this time allocation).

Note: LOU being at ambient temperature, IMT objectives on HIFI will be limited. Specifically, the LO power should be limited and higher frequency channel should not used (IID-B). The bias range to the mixers and electromagnets should also be restricted (IID-B).

The 2 other instruments are OFF during this phase.

## 5.8.4.8. SPIRE and PACS parallel mode

The background satellite configuration for SPIRE photometer commissioning shall be a "PM B1" "Unit B", as specified in detail in §5.9.2. This may be summarised by the following table:

### Satellite state

CDMS mode	NOM	note:		ACMS mode	SCM (Earth)
TM / OBT	B	Rx1 Rx2 rate	125 / 4k	PM & SW & B	B1N [A1S] A
PM & SW	B1N [A1N]	TME Tx rate	1.5Mbps	CRS / FDIR	2A, 1S / AFO
SCBP / MTL	A-3 / Stopped	Tx chain	T.2 A.B MGA	GYROs	A,C,D IF 1 ON
FDIR / SrvCBH	AFO / R only	Rx 1 Ant.	MGA	STRs	B (LCL A ON)
launch straps	all separated	Rx 2 Ant.	LGA1	RWs	1,3,4 ON
PCDU IF / HPS	IF B / all R	CCU	A OFF, B ON *	LV	A OFF B ON
Battery	CHARGED	SPIRE	as needed	THR	B CBH-T ON
Power domain	SA	HIFI	OFF	SREM	ON
Mass Memory	(≥) 1 bank (no0)	PACS	as needed	VMC	OFF

### GSE support

Power source	SAS 1475W	TM / TC source	MGA VC1	ENV simulator	closed loop
--------------	-----------	----------------	---------	---------------	-------------

For this specific test the CCU A shall be marked failed and left OFF. Its sensors shall be so the one connected to the CRYOSCOE to monitor the test.

The detailed program shall conform to RD106 §4.6.5.

The test start and end point shall be with the 3 instruments in STBY.

Then SPIRE and PACS shall be set for parallel operation test.

The overall test sequence shall last no more than 5 hours (S/C initial and final configuration is not part of this time allocation).

## 5.8.4.9. Test end

The test end shall return the satellite in a safe configuration that is the initial where "as needed" stands for the relevant instrument being "OFF".

All board data not yet recovered, shall be downloaded from the S/C as per generic §5.7.1.3 requirements.

The TM / TC source may be turned to umbilical connection to ease the post test data retrieval.

### **Success criteria**

All on board stored TM shall be retrieved, and shall be identical to the TM data intercepted thanks to umbilical link monitoring.

The real time TM packets shall not meanwhile indicate any No-Go.

All essential and non essential TM packets shall continue to be available meanwhile download in real time TM.

No event packet types (5,2) and (5,4) nor TC rejection (1,2) or (1,8) shall be generated.

Success criteria for instrument part of the test are defined by RD1 §6.

## 5.8.5. MODE TRANSITIONS

### 5.8.5.1. Objective

The objective of this sequence is to test the satellite (manual) mode transitions, and specifically the ones implying the instrument command in STAND-BY mode.

This sequence considers the satellite commanding in its different possible modes. This kind of operation in flight is expected to be nominally run from ground or at least in "visibility".

### 5.8.5.2. Test brief description

The test is structured as a suite of small independent tests.

In the way this specification is written, each step is defined to be run immediately following the previous one. More precisely, the configuration at entry of a step is defined by the configuration at output of the previous step. The chaining with respect to the specification paragraph is summarised on the following figure:

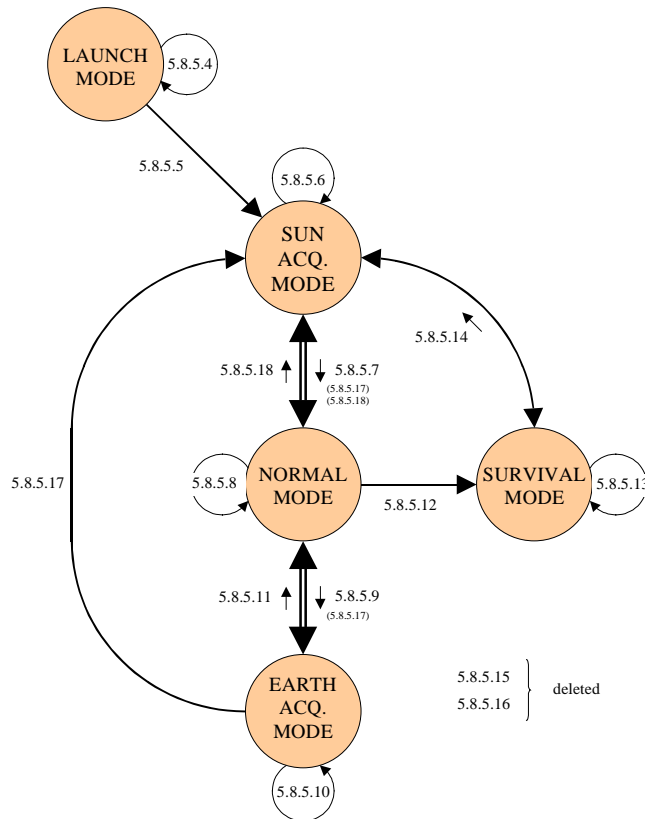

mode transition test summary

Activities are listed in a chronological order.

The following diagram depicts the CDMS and ACMS mode and state chaining along the full sequence (in bold red, are the CDMS transitions that are the subject of each sub-sequence).

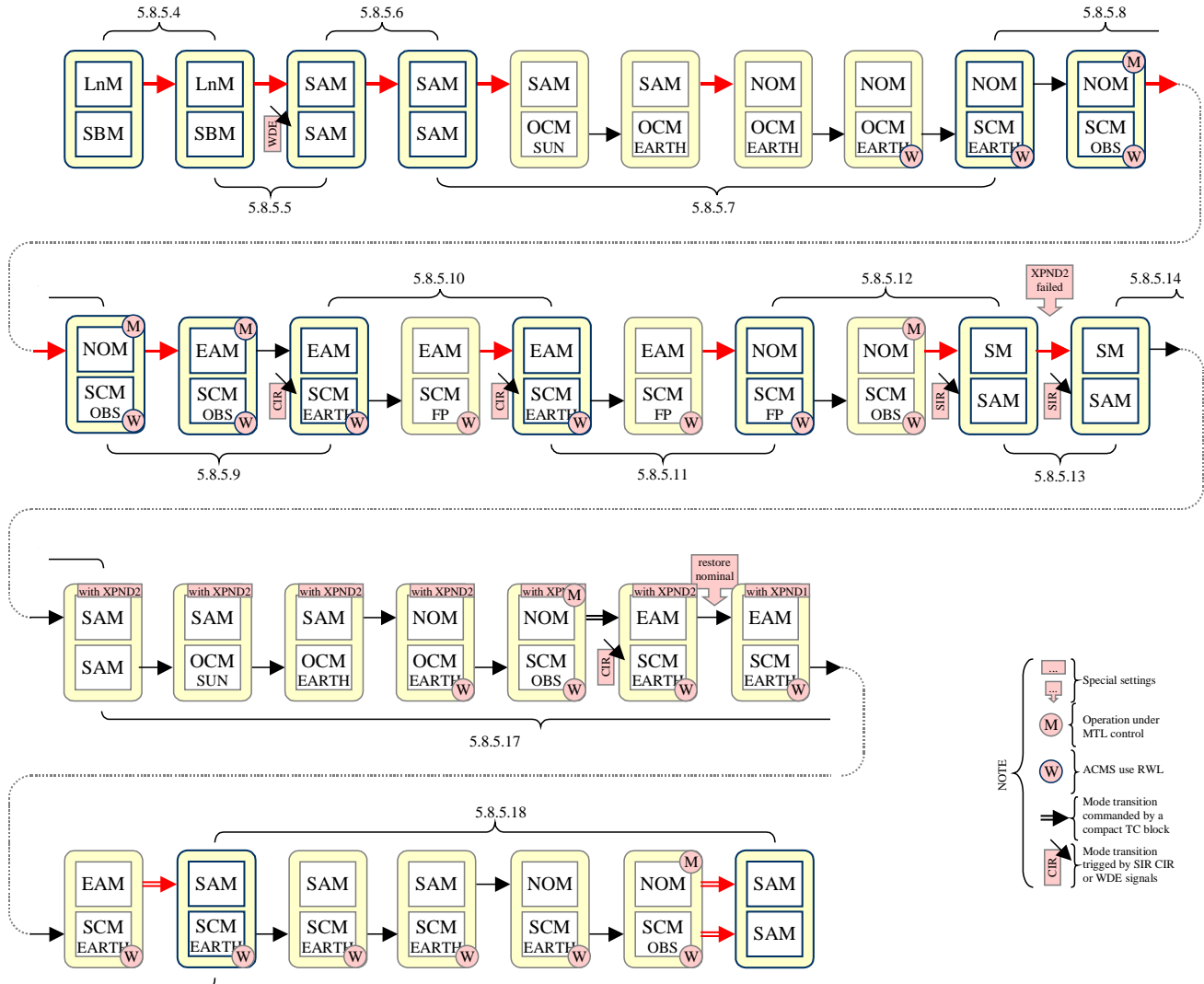

(dark bleu steps are the one for which a satellite state table is given in the following chapters).

Note : in above diagram, as for satellite state table, "Earth" and "Sun" pointing refers to the "Q<sub>CIR</sub>" and "Q<sub>SIR</sub>" quaternions respectively. Those are fixed inertial vectors, that are nominally updated every day (operation also called "ephemeris" upload in the sub-sequences). When those settings are active, the ACMS pointing success criteria shall be defined with respect to the uploaded active value (not the actual Sun / Earth position in ENV simulation).

The transition chaining implies that more than one SM to SAM, SAM to NOM and NOM to EAM transition shall be commanded (small chapter references in the previous page figure). This is used to vary the initial configuration to test the proper reconfiguration. This specifically includes:

- some "A" unit marked failed,
- some "B" unit marked failed (with survival register handling exercise),
- some ASW "service" disabled,
- different instrument being ON (which allow to test their respective OBCP when applicable).

The test does not intend to be exhaustive with all the possible cases. This shall be covered at lower level by CDMS and SVM SIT. But the objective is to sample realistic cases, and most of all, to provide observable for the automatic ON / OFF sequences that the mode transitions shall -or shall not- ensure.

### Important note 1

The following sequence step specification rely heavily on details of the CDMS ASW specification not necessarily fully finalised (so called "amendments"). Any case of apparent discrepancies between the following requirements and RD24 shall be bring to the attention of the writer for resolution (i.e. agreed change w.r.t S/C operation baseline as considered in the herein document, or open point yet into negotiation).

### Important note 2

This test sequence should be ideally run using only the RF link for S/C commanding. Due to incessant transitions, this is lowly time effective. It is so allowed to conduct the S/C operation from the umbilical interface. The S/C state tables are nevertheless written in the following paragraph, according a RF link logic.

### Important note 3

Each mode transition sequence is composed of two steps. The "transition sequence" and "preparatory tasks".

The "preparatory tasks" manage the S/C configuration for the test, starting from the S/C state at the end of the previous sequence. This step is not in itself part of the test, and only ensures the transition between previous S/C state and the needed one. In case of test restart, it is not necessary to bring the S/C in the exact state it should have at the end of the previous transition. The "preparatory tasks" may be adapted to cut non necessary intermediate configuration, as long as the one at entry in the "transition sequence" is the same.



### 5.8.5.3. Test start configuration

The initial state shall simulate a satellite in launch mode, waiting for launch, in "PM A1", "unit A" configuration. The configuration is strictly identical to the one at the end of §7.8.2.4.4. except for the use of the BATSIM.

This initial state shall be:

#### *Satellite state*

CDMS mode	LAUNCH	note:		ACMS mode	SBM presep
TM/OBT	A	Rx1 Rx2 rate	125 / 4k	PM & SW & B	A1N [B1S] A
PM & SW	A1N [B1N]	TME / Tx rate	150k	CRS / FDIR	1A, 2S / AFS
SCBP / MTL	A-0 / Stopped	Tx chain	T.1(RF OFF) A.OFF(LCL ON)	GYROs	A,B,C IF 1 ON
FDIR / SrvCBH	AFS / N only	Rx 1 Ant.	LGA1	STRs	OFF
launch straps	not separated	Rx 2 Ant.	LGA2	RWs	OFF
PCDU IF / HPS	IF A / all N	CCU	A,B ON 8s-Hk	LV	A & B OFF
Battery	charged (BS (1))	SPIRE	OFF	THR	A & B OFF
Power domain	SA < 6 sections	HIFI	OFF	SREM	OFF
Mass Memory	(≥) 1 bank (no1)	PACS	OFF	VMC	OFF

#### *GSE support*

Power source	SAS-6	TM / TC source	UMB 4k VCO	ENV simulator	stand-by
--------------	-------	----------------	------------	---------------	----------

(1): there no need to force the battery to VEC-MAX, as this is not a test objective to run a representative launch sequence.

The ENV simulation shall be set-up so that the Sun and Earth directions are separated by 30°. The ENV simulator initial condition for separation shall be similar to those specified for the launch sequence. The ENV simulation shall be set-up so that the Sun and Earth position propagation during the test time is limited, in order to limit the risk of ARAD alarm whenever ACMS commands would be a few offset from their planed timeline. Note : the setting can be typically a L2 position, but does no need to be representative of any possibly real flight condition (specifically for separation step).

## 5.8.5.4. Launch to Launch

The S/C configuration shall be altered the following way:

- (start configuration)
- (RFDN is AAAA per start configuration)
- The umbilical power supply shall be turned off so that satellite is supplied from the BS.

The TC shall be sent to request the satellite to be set in launch mode (arm / fire).

### success criteria

The satellite shall be reset with default launch configuration. Specifically the TTC configuration alteration shall be corrected (flight branch SW only).

### Satellite state

CDMS mode	LAUNCH	note:		ACMS mode	SBM presep
TM/OBT	A	Rx1 / Rx2 rate	4kbps	PM & SW & B	A1N [B1S] A
PM & SW	A1N [B1N]	TME / Tx rate	5kbps	CRS / FDIR	1A, 2S / AFS
SCBP / MTL	A-0 / Stopped	Tx chain	T.1(RF OFF) A.OFF(LCL ON)	GYROs	A,B,C IF 1 ON
FDIR / SrvCBH	AFS / N only	Rx 1 Ant.	LGA1	STRs	OFF
launch straps	not separated	Rx 2 Ant.	LGA2	RWs	OFF
PCDU IF / HPS	IF A / all N	CCU	A,B ON 8s-Hk	LV	A & B OFF
Battery	charged	SPIRE	OFF	THR	A & B OFF
Power domain	BAT	HIFI	OFF	SREM	OFF
Mass Memory	(≥) 1 bank (no1)	PACS	OFF	VMC	OFF

### GSE support

Power source	BS	TC source	UMB 4k VCO	ENV simulator	stand-by
--------------	----	-----------	------------	---------------	----------

## 5.8.5.5. Launch to SAM

### 5.8.5.5.1. Preparatory task

Starting from previous sequence end state, the S/C configuration shall be complemented and altered the following way:

- The TM rate (TM encoder and XPND) shall be set to 150kbps, and XPND 1 TC rate shall be set to 125bps.
- the RFDN configuration shall be set in all "A" position (XPND RX1 on LGA1, XPND RX2 on LGA2, position) using CMDS\_TC(2,3) to keep the ASW configuration table in normal configuration state. WARNING, it is recalled that the use of the use of the CDMS\_TC(2,3) to move the RF switches, implies to provide a 20s minimum waiting time between TC to prevent an overheating of the CPDU driver. The all "B" should be set, but this choice allows to observe the automatic configuration "confirmation" performed by the ASW at separation. The all A position gives the same result but is not the baseline reference (ref. SVM user manual volume 3, TTC subsystem).
- the RW 3, and GYRO IF 2 LCL shall be turned OFF (warning : the GYRO IF 1 LCL shall remain ON).
- The umbilical power supply shall be off so that satellite is supplied from the BS.

### 5.8.5.5.2. Transition sequence

The following TC sequence shall be sent to force the S/C mode transition to SAM while indeed, separation straps are still in a "non separated" state. Procedure details shall follow the applicable UM instruction. But sequence shall be the following :

- The CMDS shall be commanded in SAM by the applicable TC (arm / fire) in BD mode (no RF TM).
  - > No RF TM signal shall be get despite SAM mode transition (an RM command is missing for TWTA turn ON).
- After 4 minutes (to check against the TWTA non activation), a TC to service 112 shall be sent in BD mode to turn ON the TWTA in use.
  - > TM shall appear on a 5kbps downlink basis (default SAM after separation).  
The RF link shall be checked, but TM/TC link may be left in umbilical configuration and BD mode to save test time.
  - > The RF link shall be checked, but TM/TC link may be left in umbilical configuration and BD mode to save test time.
- The THR A and THR B LCL shall be turned ON (RM action)

Then the ACMS shall then be commanded in SAM using the applicable TC "force separation" (arm/fire).

Note : this command requires that both ACMS RM to be disabled first.

The two ACMS RM shall be re-enabled after the command.

# Herschel S/C IST specification

REFERENCE: H-P-2-ASP-SP-0939

DATE: December 20<sup>th</sup> 2007

ISSUE: 6.0

Page : 126

The S/C shall stabilise itself in SAM / SAM mode.

Note: the full transition would require to reprogram the CMD5 and ACMS RM (i.e. the PAP) to provide nominal operation while straps remains in "not separated" state. This shall not be considered here (this trouble is managed by the following sequence "preparatory tasks").

### success criteria

The final satellite state and the sequence of event shall be similar to the launch sequence case specifically w.r.t to ACMS performance.

Specifically: the TTC configuration alteration shall be corrected (flight branch SW only).

The STR and GYRO IF LCL shall be all ON (nominal and redundant).

The final state shall be:

### Satellite state

CDMS mode	SAM	note:	RFDN= BBBB	ACMS mode	SAM (PT CS)
TM/OBT	A	Rx rate	4kbps	OBT, PM & SW	A- A1N [B1S]
PM & SW	A1N [B1N]	TM rate	5kbps	CRS / FDIR	1A, 2S / AFS
SCBP / MTL	A-5 / Stopped	Tx chain	T.1 A.A LGA1	GYROs	A,B,C IF 1 ON
FDIR / SrvCBH	AFS / N only	Rx 1 Ant.	LGA1	STRs	OFF LCLs ON
launch straps	not separated (2)	Rx 2 Ant.	LGA2	RWs	OFF LCLs ON
PCDU IF / HPS	IF A / all N	CCU	A,B ON 8s-Hk	LV	A ON B OFF
Battery	charged (1)	SPIRE	OFF	THR	A CBH-T ON
Power Source	BAT	HIFI	OFF	SREM	OFF
Mass Memory	(≥) 1 bank (no1)	PACS	OFF	VMC	ON image strd

### GSE support

Power source	BS	TM / TC source	UMB(2) 4k VCO	ENV simulator	closed loop
--------------	----	----------------	---------------	---------------	-------------

(1): the test do not follow a representative launch timing, then SOC is not a criteria.

(2): as based on launch strap statuses

(3) : to simplify the test, LGA1 RF link would be nominal.

## 5.8.5.6. SAM to SAM

### 5.8.5.6.1. Preparatory tasks

Starting from previous sequence end state, the S/C configuration shall be complemented and altered the following way:

First:

- the S/C power supply shall be transferred to SAS (1700W setting),
- the separation straps shall be open to restore nominal operation conditions,
  - > this shall imply the triggering of the CDMS RM separation PAP (without consequence), the restoration of adapted CDMS alarm level 3 and 4 management, and the enabling of the ACMS RM ARAD alarms (disabled so far),
- the VMC shall be turned OFF (there is no need to retrieve the images),
- the SREM shall be turn ON and configured for normal operation including TM storage and real time downlink with 1 minute cycle setting (note, this setting may be delayed after the 150kbps transition and enabling of non essential TM downlink Hk TM, to access the SREM status information in the P64 packet).

Then, the S/C configuration shall be altered the following way:

- The TM rate shall be set to 150kbps (blind TC from RF link),
- Enable downlink of periodic non essential Hk TM packets.
- The THR B LCL shall be disabled (action at CDMS level),
- The STR B LCL shall be turned OFF.

### 5.8.5.6.2. Transition sequence

The TC shall be sent to request the satellite to be set in SAM mode (arm / fire).

#### **success criteria**

The satellite shall be reset with default after separation SAM configuration.

Warning: the default SAM configuration is not the default SAM configuration which shall be obtained when the transition is performed from launch mode when the separation event is detected. The obtained TTC setting shall be modified, and TM data shall be reduced to sub-sampled essential HK.

Warning: as the transition is commanded from TC, there is no specific SW re-initialisation, then the SREM operation shall be unaffected except for the disabling of its TM down link in real time. The SREM TM stored in SSMM shall be specifically unaffected.

# Herschel S/C IST specification

REFERENCE: H-P-2-ASP-SP-0939

DATE: December 20<sup>th</sup> 2007

ISSUE: 6.0

Page : 128

The final state shall be:

## Satellite state

CDMS mode	SAM	note:		ACMS mode	SAM (PT CS)
TM/OBT	A	Rx1 Rx2 rate	125 / 125	PM & SW & B	A1N [B1S] A
PM & SW	A1N [B1N]	TME / Tx rate	500bps	CRS / FDIR	1A, 2S / AFS
SCBP / MTL	A-5 / Stopped	Tx chain	T.1 A.A LGA1	GYROs	A,B,C IF 1 ON
FDIR / SrvCBH	AFS / N only	Rx 1 Ant.	LGA1	STRs	OFF LCLs ON
launch straps	all separated	Rx 2 Ant.	MGA	RWs	OFF LCLs ON
PCDU IF / HPS	IF A / all N	CCU	A,B ON Hk	LV	A ON B OFF
Battery	charged (BS)	SPIRE	OFF	THR	A CBH-T ON
Power domain	SA	HIFI	OFF	SREM	ON
Mass Memory	(≥) 1 bank (no1)	PACS	OFF	VMC	OFF

## GSE support

Power source	SAS 1700W	TM / TC source	UMB(1) 4k VCO	ENV simulator	closed loop
--------------	-----------	----------------	---------------	---------------	-------------

(1) : to simplify the test, LGA1 RF link would be nominal.

The ACMS and SREM, shall have been unaffected.

## 5.8.5.7. SAM to NOM

### 5.8.5.7.1. Preparatory tasks

The ACMS shall be loaded with the proper data to operate in OCM mode (ephemeris, etc.).

- In a first step to set the RCS in "FINE" to enter the SAM /FINE state.
- The STR-1 shall be turn ON and configured.
  - > STR-1 shall reach the "tracking" mode.

To quicken this task, the TC-TM can be commanded back to 4k/150k, but the initial state shall be restore after that in 4k/5k and enhanced visibility TM filter configuration.

### 5.8.5.7.2. Transition sequence

The command to set the ACMS in OCM mode, pointing to the SUN. This shall include:

- (moved in preparatory)(moved in preparatory)
- The ACMS "low rate OCM" telemetry shall be activated and "law rate SAM" telemetry de-activated.
- when stabilised, the ACMS shall be commanded in OCM with a target corresponding to Sun (with a small offset to keep the transition observable). The attitude shall be controlled for 5 minutes.
- The command shall be sent to set the ACMS to point the Earth (arm/fire).
- The SAS power shall be reduced to 1475W.
- When the S/C Earth pointing is established, the TC shall be sent to request the satellite to be set in NOM mode (arm / fire).

Note: This command shall specifically results in the TTC reconfiguration.

The RF link shall be re-acquired when TWTA operation is restarted by the S/C.

The sequence shall then be complemented at the ACMS level by setting up the RW.

- the RW shall be turned ON,
- the RW shall be biased at a low level to save test time, yet a level large enough to support the following sequence of slews and manoeuvres without an RW speed alarm,
- the ACMS FDIR shall be switched to AFO.

Then the ACMS shall be finally commanded in SCM mode (keeping the same Earth target).

# Herschel S/C IST specification

REFERENCE: H-P-2-ASP-SP-0939

DATE: December 20<sup>th</sup> 2007

ISSUE: 6.0

Page : 130

## success criteria

The final satellite state and the sequence of event shall be similar to the one experienced in the frame of the launch test sequence.

This final state shall be:

### Satellite state

CDMS mode	NOM	note:		ACMS mode	SCM (PT Earth)
TM/OBT	A	Rx rate	4kbps	PM & SW & B	A1N [B1S] A
PM & SW	A1N [B1N]	TM rate	150kbps	CRS / FDIR	1A, 2S / AFO
SCBP / MTL	A-5 / Stopped	Tx chain	T.1 A.A MGA	GYROs	A,B,C IF 1 ON
FDIR / SrvCBH	AFO / N only	Rx 1 Ant.	MGA	STRs	A (LCL B ON)
launch straps	all separated	Rx 2 Ant.	LGA1	RWs	1,2,3,4 ON
PCDU	IF A / all N	CCU	A,B ON Hk	LV	A ON B OFF
Battery	charged (BS)	SPIRE	OFF	THR	A CBH-T ON
Power domain	SA	HIFI	OFF	SREM	ON
Mass Memory	(≥) 1 bank (no1)	PACS	OFF	VMC	OFF

### GSE support

Power source	SAS 1475W	TM / TC source	UMB(1) 4k VCO	ENV simulator	closed loop
--------------	-----------	----------------	---------------	---------------	-------------

(1) : to simplify the test, MGA RF link would be nominal.



## 5.8.5.8. NOM to NOM

### 5.8.5.8.1. Preparatory tasks

- the SREM shall be turned OFF.
- The CDMS FDIR shall be turned to AFS.
- the 3 instruments shall be turned ON and brought to their stand-by state.
- a short MTL with shall be loaded with a timing such that any spurious sub-schedule skip generated by the NOM to NOM command may be observable. The MTL shall present a rate of command of 1 per second or more, such that (large) command delays may be observable. Those MTL command may be made of any incautious command or command pattern repetition (i.e. do not need to make a functional meaning).
- volunteer instrument for this sequence, PACS shall be configured for operation in spectrometer mode with parameters optimised for generating a maximum of science packet data flow.
- the PACS observation setting shall be associated with a minimum MTL TC activity and an MTL managed ACMS setting for a line scan or raster.
- Real time science downlink shall be enabled.

The S/C configuration shall be altered the following way:

- The TM rate shall be set to 1.5Mbps, the XPND 1 TC rate to 125bps.
- The CCU monitoring TM and periodic CDMS Hk TM downlink shall be disabled.
- The STR 2 and GYRO IF 2 LCL shall be turned OFF.

This intermediate reference state shall be:

Satellite ***INTERMEDIATE*** state:

CDMS mode	NOM	note:		ACMS mode	SCM (OBS)
TM/OBT	A	Rx1 / Rx2 rate	125 / 4k	PM & SW & B	A1N [B1S] A
PM & SW	A1N [B1N]	TM rate	1.5Mbps	CRS / FDIR	1A, 2S / AFO
SCBP / MTL	A-4 / running	Tx chain	T.1 A.A MGA	GYROs	A,B,C IF 1 ON
FDIR / SrvCBH	AFS / N only	Rx 1 Ant.	MGA	STRs	A ON B OFF
launch straps	all separated	Rx 2 Ant.	LGA1	RWs	1,2,3,4 ON (IF2 OFF)
PCDU IF / HPS	IF A / all N	CCU	A,B ON HK	LV	A ON B OFF
Battery	charged (BS)	SPIRE	STBY	THR	A CBH-T ON
Power domain	SA	HIFI	STBY	SREM	OFF
Mass Memory	(≥) 1 bank (no1)	PACS	SPECTRO	VMC	OFF

*GSE support*

Power source	SAS 1475W	TM / TC source	UMB(1) 4k VCO	ENV simulator	closed loop
--------------	-----------	----------------	---------------	---------------	-------------

(1) : to simplify the test, MGA RF link would be nominal.

### 5.8.5.8.2. Transition sequence

The TC shall be sent to request the satellite to be set in NOM mode (arm / fire).

No ACMS command shall be sent (ACMS shall be unaffected by the CDMS mode change command).

No Instrument command shall be sent (instruments shall be unaffected by the CDMS mode command).

#### success criteria

The satellite shall be reset with default NOM configuration with the following specificities.

- The ACMS operation continuity shall have not been affected (including AFO mode).
- The instrument and ACMS operation by MTL shall not be affected (the bus profile shall be unaffected).
- All the TM shall be again available in the downlink but not real time science.
- The CDMS FDIR shall be set back to AFO.
- The GYRO IF 2 LCL and STR 2 LCL shall be back ON.
- The SREM shall still be OFF.

# Herschel S/C IST specification

REFERENCE: H-P-2-ASP-SP-0939

DATE: December 20<sup>th</sup> 2007

ISSUE: 6.0

Page : 133

This final state shall be:

## Satellite state

CDMS mode	NOM	note:		ACMS mode	SCM (OBS)
TM/OBT	A	Rx1 / Rx2 rate	4k / 125	PM & SW & B	A1N [B1S] A
PM & SW	A1N [B1N]	TM rate	150kbps	CRS / FDIR	1A, 2S / AFO
SCBP / MTL	A-4 / running	Tx chain	T.1 A.A MGA	GYROs	A,B,C IF 1 ON
FDIR / SrvCBH	AFO / N only	Rx 1 Ant.	MGA	STRs	A (LCL B ON)
launch straps	all separated	Rx 2 Ant.	LGA1	RWs	1,2,3,4 ON
PCDU IF / HPS	IF A / all N	CCU	A,B ON HK	LV	A On B OFF
Battery	charged (BS)	SPIRE	STBY	THR	A CBH-T ON
Power domain	SA	HIFI	STBY	SREM	OFF
Mass Memory	(≥) 1 bank (no1)	PACS	SPECTRO	VMC	OFF

## GSE support

Power source	SAS 1475W	TM / TC source	UMB 4k VCO	ENV simulator	closed loop
--------------	-----------	----------------	------------	---------------	-------------

(1) : to simplify the test, MGA RF link would be nominal.

## 5.8.5.9. NOM to EAM

### 5.8.5.9.1. Preparatory tasks

Starting from previous sequence end state:

- the SREM shall be turned back in operation.

The instrument shall still be running, and ACMS still scanning the sky with periodic MTL command, but the MTL contain shall be designed so that it contain only ACMS commands and instrument commands that are harmless when spuriously sent when the instrument is in STBY rather than current SPECTRO meter. They shall be specifically chosen to prevent that a spurious reception of those commands by the instrument generate any event with an entry in the EAT table (FDIR).

The EAM Earth pointing data (including propagation) loaded in ACMS earlier in the test and the ENV simulator setting shall still be coherent and not possibly trig an AAD alarm, nor RW speed trouble (RW biasing) when commanding back the S/C toward Earth.

The S/C configuration shall be altered the following way:

- The TM rate shall be set to 1.5Mbps, the XPND 1 TC rate to 125bps.
- The CCU monitoring TM and periodic CDMS periodic Hk TM downlink shall be disabled.
- The STR 2 and GYRO IF 2 LCL shall be turned OFF.

This intermediate reference state shall be so the same as for the NOM to NOM transition except for SREM being ON, missing TM packets instead of additive real time science, and AFO mode being valid.

### 5.8.5.9.2. Transition sequence part 1

The TC shall be sent to request the CDMS to be set in EAM mode (arm / fire).

No ACMS command shall be sent.

No instrument command shall be sent.

Warning: this is not a nominal way to command EAM by TC.

#### **success criteria**

The satellite shall be set with default EAM configuration, as set by the CDMU ASW (i.e. without the actions initiated in case of level 3 FDIR transition, by the RM and the BSW / ASW reset). Specifically:

- The instrument operation shall have been stopped and the 3 of them shall be in STBY.
- CDMS FDIR shall be AFS.
- Only HK TM shall be enabled (including periodic and non essential, including CCU and instrument). As the instrument will be set in STBY, the fact that real time science is disabled will be checked by requesting the list of enabled packets to service 14.
- the MTL shall still be running unaffected.
- The SREM and SCBP state shall be unaffected.

- The ACMS shall be unaffected, with respect to its last MTL command before the EAM command.

The final state shall be:

*Satellite state*

CDMS mode	EAM	note:		ACMS mode	SCM (OBS)
TM/OBT	A	Rx rate	4k / 125	PM & SW & B	A1N [B1S] A
PM & SW	A1N [B1N]	TM rate	150kbps	CRS / FDIR	1A, 2S / AFO
SCBP / MTL	A-1 / running	Tx chain	T.1 A.A MGA	GYROs	A,B,C IF 1 ON
FDIR / SrvCBH	AFS / N only	Rx 1 Ant.	MGA	STRs	A (LCL B ON)
launch straps	all separated	Rx 2 Ant.	LGA1	RWs	1,2,3,4 ON
PCDU IF / HPS	IF A / all N	CCU	A,B ON Hk	LV	A On B OFF
Battery	charged (BS)	SPIRE	STBY	THR	A CBH-T ON
Power domain	SA	HIFI	STBY	SREM	ON
Mass Memory	(≥) 1 bank (no1)	PACS	STBY	VMC	OFF

*GSE support*

Power source	SAS 1475W	TM / TC source	UMB(1) 4k VCO	ENV simulator	closed loop
--------------	-----------	----------------	---------------	---------------	-------------

(1) : to simplify the test, MGA RF link would be nominal.

*5.8.5.9.3. Transition sequence part 2*

After proper observation of the above criteria, the EAM transition will be completed.

A TC shall be sent to stop the MTL.

A TC shall be sent to set back the SCBP to profile 1.

Two direct TC to the CPDU shall be sent to set the CIR flag, then reset it after 14s.

**test completion success criteria**

The satellite shall be set with full EAM configuration, specifically:

- the MTL shall be stopped,
- the S/C shall be pointed to the Earth.

The final state shall be:

# Herschel S/C IST specification

REFERENCE: H-P-2-ASP-SP-0939

DATE: December 20<sup>th</sup> 2007

ISSUE: 6.0

Page : 136

## Satellite state

CDMS mode	EAM	note:		ACMS mode	SCM (Earth)
TM/OBT	A	Rx rate	4k / 125	PM & SW & B	A1N [B1S] A
PM & SW	A1N [B1N]	TM rate	150kbps	CRS / FDIR	1A, 2S / AFO
SCBP / MTL	A-1 / Stopped	Tx chain	T.1 A.A MGA	GYROs	A,B,C IF 1 ON
FDIR / SrvCBH	AFS / N only	Rx 1 Ant.	MGA	STRs	A (LCL B ON)
launch straps	all separated	Rx 2 Ant.	LGA1	RWs	1,2,3,4 ON
PCDU IF / CBH	IF A / all N	CCU	A,B ON Hk	LV	A ON B OFF
Battery	charged (BS)	SPIRE	STBY	THR	A CBH-T ON
Power domain	SA	HIFI	STBY	SREM	ON
Mass Memory	(≥) 1 bank (no1)	PACS	STBY	VMC	OFF

## GSE support

Power source	SAS 1475W	TM / TC source	UMB(1) 4k VCO	ENV simulator	closed loop
--------------	-----------	----------------	---------------	---------------	-------------

(1) : to simplify the test, MGA RF link would be nominal.

## 5.8.5.10. EAM to EAM

### 5.8.5.10.1. Preparatory tasks

- the ACMS pointing shall be offset with respect to EAM reference for one fix pointing about mid course between Earth and Sun (with proper margin w.r.t. ARAD).

The S/C configuration shall be altered in the following way:

- the STR-2 shall be turned ON (simulating a check out : diagnostic telemetry shall be activated).
- the volunteer instrument, SPIRE shall be set again in serendipity mode (which requires SCBP 3 selection).
- MTL shall be restarted.
- the real time downlink of SPIRE science data shall be enabled.
- CDMS FDIR setting shall be set to AFO.
- The TM rate shall be set to 1.5Mbps, the TC rate to 125bps.
- The CCU monitoring TM and periodic CDMS periodic Hk TM downlink shall be disabled.
- The GYRO IF 2 LCL shall be turned OFF.

### 5.8.5.10.2. Transition sequence

The nominal quad of TC to request the satellite to be set in EAM mode shall be sent:

- Stop MTL service, set CIR flag, set EAM mode (arm / fire).

No ACMS command shall be sent.

No instrument command shall be sent.

#### **success criteria**

The satellite shall be in default EAM configuration (except STR), specifically :

The CIR flag shall be cleared as a result of the ASW action.

The TTC hardware configuration shall be reset to nominal EAM configuration.

The instrument operation shall have been again stopped and the 3 of them shall be in STBY.

The FDIR mode AFS.

Only HK TM shall be enabled (including periodic and non essential, including CCU and instrument). As the instrument will be set in STBY, the fact that real time science is disabled will be checked by requesting the list of enabled packets to service 14.

The MTL operation shall still be disabled (the MTL disabling reinforcement attempt shall generate no perturbation).

The STR B ON state shall be unaffected, the GYRO I/F2 LCL shall be back ON.

The final state shall be:

*Satellite state*

CDMS mode	EAM	note:		ACMS mode	SCM (FP 1/2)
TM/OBT	A	Rx1 / Rx2 rate	4k / 125	PM & SW	A1N [B1S]
PM & SW	A1N [B1N]	TM rate	150kbps	CRS / FDIR	1A, 2S / AFO
SCBP / MTL	A-1 / Stopped	Tx chain	T.1 A.A MGA	GYROs	A,B,C IF 1 ON
FDIR / SrvCBH	AFS / N only	Rx 1 Ant.	MGA	STRs	A & B ON
launch straps	all separated	Rx 2 Ant.	LGA1	RWs	1,2,3,4 ON
PCDU IF / HPS	IF A / all N	CCU	A,B ON Hk	LV	A ON B OFF
Battery	charged (BS)	SPIRE	STBY	THR	A CBH-T ON
Power domain	SA	HIFI	STBY	SREM	ON
Mass Memory	(≥) 1 bank (no1)	PACS	STBY	VMC	OFF

*GSE support*

Power source	SAS 1475W	TM / TC source	UMB(1) 4k VCO	ENV simulator	closed loop
--------------	-----------	----------------	---------------	---------------	-------------

(1) : to simplify the test, MGA RF link would be nominal.

5.8.5.11. EAM to NOM

*5.8.5.11.1. Preparatory tasks*

- the ACMS pointing shall be offset with respect to EAM reference pointing for one fix pointing about mid course between Earth and Sun (with proper margin w.r.t. ARAD).

The S/C configuration shall be altered the following way:

- the volunteer instrument, SPIRE shall be set in PHOTOMETER mode (which requires SCBP 3 selection).
- MTL shall nevertheless not be started.
- the real time downlink of SPIRE science data shall be enabled.
- The TM rate shall be set to 1.5Mbps, the TC rate to 125bps.
- The CCU monitoring TM and periodic CDMS periodic Hk TM downlink shall be disabled.
- The GYRO IF 2 LCL shall be turned OFF.
- The SREM operation shall be stopped and the unit turned OFF.



## 5.8.5.11.2. Transition sequence

The TC shall be sent to request the satellite to be set in NOM mode (arm / fire).

No ACMS command shall be sent (ACMS shall be unaffected by the CDMS mode change).

No instrument command shall be sent.

### success criteria

The satellite shall be set with default NOM configuration, specifically:

The TTC hardware configuration shall be reset to nominal NOM configuration.

All the TM shall be enabled, including the SPIRE real time science.

The FDIR mode shall be AFO.

But :

The ACMS operation and pointing shall be unaffected.

The instrument operation shall be unaffected (including SCBP).

The MTL operation shall still be disabled.

The STR and SREM state shall be unaffected.

The final state shall be:

### Satellite state

CDMS mode	NOM	note:		ACMS mode	SCM (FP 1/2)
TM/OBT	A	Rx1 Rx2 rate	4k/ 125	PM & SW & B	A1N [B1S] A
PM & SW	A1N [B1N]	TME / Tx rate	150kbps	CRS / FDIR	1A, 2S / AFO
SCBP / MTL	A-3 / running	Tx chain	T.1 A.A MGA	GYROs	A,B,C IF 1 ON
FDIR / SrvCBH	AFO / N only	Rx 1 Ant.	MGA	STRs	A & B ON
launch straps	all separated	Rx 2 Ant.	LGA1	RWs	1,2,3,4 ON
PCDU IF /HPS	IF A / all N	CCU	A,B ON HK	LV	A ON B OFF
Battery	charged (BS)	SPIRE	PHOTOMETER	THR	A CBH-T ON
Power domain	SA	HIFI	STBY	SREM	OFF
Mass Memory	(≥) 1 bank (no1)	PACS	STBY	VMC	OFF

### GSE support

Power source	SAS 1475W	TC source	UMB(1° 4k VCO)	ENV simulator	closed loop
--------------	-----------	-----------	----------------	---------------	-------------

(1) : to simplify the test, MGA RF link would be nominal.

## 5.8.5.12. NOM to SM

### 5.8.5.12.1. Preparatory tasks

- the MTL shall be started for an observation with SPIRE associated with a line scan or raster. The ACMS setting shall include the SRPE option activation.
- the ACMS pointing (line scan or raster) shall have a significant offset with respect to SUN in the AAD range.
- the SREM operation shall be restart (unit back ON).

The S/C configuration shall be altered the following way:

- The CCU monitoring TM and essential CDMS Hk TM downlink shall be disabled.
- The CCU monitoring shall be set for 8s sampling.
- The GYRO IF 2 LCL shall be turned OFF.
- Some TCS table entries shall be modified with respect to default value. The modification shall be harmless if this procedure shall be repeated in TVTB, but may be smaller than 1° when change remain observable.

### 5.8.5.12.2. Transition sequence

The TC shall be sent to request the satellite to be set in SM mode. For that, the contingency RM transition shall be used.

- The RF-SCE shall be commanded for uplink operation at 125bps on LGA1 (keeping downlink on umbilical to keep test simpler and keeping more S/C observability).
- TC shall be sent in "blind" on MAP 0 to disable the CDMS RM A and the RM B.
- The CDPU sequence TC corresponding to the RM-CCS 0 (level 4 alarm) shall be sent on MAP 0.
- TC to re-enable the two CDMS RM shall be sent, always in BD 1 minute later.

No ACMS command shall be sent.

No instrument command shall be sent.

#### **success criteria**

The satellite shall be set with default SM configuration (see below).

The instrument shall have been turned OFF by the DNELL.

CDMS FDIR shall be AFS.

The TCS table shall have default SM settings (verification requires a diagnostic TM request).

The TM downlink shall be limited to sub-sampled essential Hk.

The CCU setting shall be restored to default (512s sampling period).

# Herschel S/C IST specification

REFERENCE: H-P-2-ASP-SP-0939

DATE: December 20<sup>th</sup> 2007

ISSUE: 6.0

Page : 141

T

The ACMS operating shall be in SAM mode as an answer to the SIR signal part of the RM-CCS-0 TC.

The SREM shall be OFF.

The final state shall be:

### Satellite state

CDMS mode	SM	note:		ACMS mode	SAM
TM/OBT	A	Rx1 / Rx2 rate	125bps	PM & SW & B	A1N [B1S]
PM & SW	B1S [B1S]	TME / Tx rate	500bps	CRS / FDIR	1A, 2S / AFS
SCBP / MTL	A-6 / Stopped	Tx chain	T.2 A.B LGA1	GYROs	A,B,C IF 1 ON
FDIR / SrvCBH	AFS / R only	Rx 1 Ant.	LGA2	STRs	OFF (LCL ON)
launch straps	all separated	Rx 2 Ant.	LGA1	RWs	OFF (LCL ON)
PCDU IF / HPS	IF B / all R	CCU	A,B ON HK	LV	A ON B OFF
Battery	charged (BS)	SPIRE	OFF	THR	A CBH-T ON
Power domain	SA	HIFI	OFF	SREM	OFF
Mass Memory	(≥) 1 bank (no1)	PACS	OFF	VMC	OFF

### GSE support

Power source	SAS 1475W	TM / TC source	UMB / LGA1 VC1	ENV simulator	closed loop
--------------	-----------	----------------	-------------------	---------------	-------------

After an initial 15minute TM recording, the S/C shall be commanded to:

- 5kbps TM (Encoder in use, XPND in use),
- the subsampling disabled,
- and the TM downlink filter enlarged after §5.7.2.3 requirements,
- The TC uplink shall be set to 4kbps (and returned to UMB if more simple to operate the test).

This shall allow to recover the success criteria data in a quicker way (specifically the TCT table).

## 5.8.5.13. SM to SM

### 5.8.5.13.1. Preparatory tasks

The S/C configuration shall be complemented the following way:

- The two CDMS RM shall be reprogrammed for operation with PM B as nominal (PAP). Corresponding attempt registers shall be reset.
- The two CDMS RM shall be reprogrammed for operation with a survival register defining units A as baseline for the RM, except for the TX chain which shall remain 2.
- The XPND1 shall be marked failed.

### 5.8.5.13.2. Transition sequence

The TC shall be sent to request the satellite to be set in SM mode. For that, the contingency RM transition shall be used again.

- The RF-SCE shall be commanded for uplink operation at 125bps on LGA1 (keeping downlink on umbilical to keep test simpler and keeping more S/C observability).
- TC shall be sent on MAP 0 to disable the CDMS RM A and RM B.
- The CDPU sequence TC corresponding to the RM-CCS 0 (level 4 alarm) shall be sent on MAP 0.
- TC to re-enable the two CDMS RM shall be sent in BD mode 1 minute later.

No ACMS command shall be sent.

No instrument command shall be sent.

#### **success criteria**

An inverted SM configuration shall be restored for CDMS in accordance with the survival register setting.

The ACMS shall be unaffected (new SIR).

The final state shall be:

## Satellite state

CDMS mode	SM	note:		ACMS mode	SAM
TM/OBT	A	Rx1 / Rx2 rate	125bps	PM & SW & B	A1N [B1S] A
PM & SW	A1S [B1S]	TME / Tx rate	500bps	CRS / FDIR	1A, 2S/ AFO
SCBP / MTL	A-6 / Stopped	Tx chain	T.2 A.B LGA1	GYROs	A,B,C IF 1 ON
FDIR / SrvCBH	AFS / R only	Rx 1 Ant.	LGA2	STRs	OFF (LCL ON)
launch straps	all separated	Rx 2 Ant.	LGA1	RWs	OFF (LCL ON)
PCDU IF / HPS	IF A / all N	CCU	A,B ON Hk	LV	A On B OFF
Battery	charged (BS)	SPIRE	OFF	THR	A CBH-T ON
Power domain	SA	HIFI	OFF	SREM	OFF
Mass Memory	(≥) 1 bank (no1)	PACS	OFF	VMC	OFF

## GSE support

Power source	SAS 1475W	TM / TC source	UMB / LGA1 VCO	ENV simulator	closed loop
--------------	-----------	----------------	-------------------	---------------	-------------

After an initial 15minute TM recording, the S/C shall be commanded to:

- 5kbps TM (Encoder in use, XPND in use),
- the subsampling disabled,
- and the TM downlink filter enlarged after §5.7.2.3 requirements.
- The TC uplink shall be set to 4kbps and UMB possibly as more simple to continue the test.

This shall allow to recover the success criteria data in a quicker way.

## 5.8.5.14. SM to SAM

### 5.8.5.14.1. Preparatory tasks

The S/C configuration shall be complemented the following way:

- The two CDMS RM shall be reprogrammed back for operation with PM A as nominal (PAP).
- The two CDMS RM shall be reprogrammed for operation with a survival register defining units B as baseline for the RM.
- The two PM A and B "PM relays 0" shall be set back to "Nominal" position.
- The two CDMS RM shall be re-enabled.

### 5.8.5.14.2. Transition sequence

- The TC shall be sent to request the satellite to be set in SAM mode (arm/fire).

No ACMS command shall be sent.

No instrument command shall be sent.

#### success criteria

Default SAM setting shall be restore, except for operation with the TX chain 2.

The final state shall be:

#### Satellite state

CDMS mode	SAM	note:		ACMS mode	SAM
TM/OBT	A	Rx1 Rx2 rate	125 / 125	PM & SW & B	A1N [B1S] A
PM & SW	A1N [B1N]	TME / Tx rate	500bps	CRS / FDIR	1A, 2S/ AFO
SCBP / MTL	A-5 / Stopped	Tx chain	T.2 A.B LGA1	GYROs	A,B,C IF 1 ON
FDIR / SrvCBH	AFS / N only	Rx 1 Ant.	MGA	STRs	OFF (LCL ON)
launch straps	all separated	Rx 2 Ant.	LGA1	RWs	OFF (LCL ON)
PCDU IF / HPS	IF A / all N	CCU	A,B ON Hk	LV	A On B OFF
Battery	charged (BS)	SPIRE	OFF	THR	A CBH-T ON
Power domain	SA	HIFI	OFF	SREM	ON
Mass Memory	(≥) 1 bank (no1)	PACS	OFF	VMC	OFF

#### GSE support

# Herschel S/C IST specification

REFERENCE: H-P-2-ASP-SP-0939

DATE: December 20<sup>th</sup> 2007

ISSUE: 6.0

Page : 145

Power source	SAS 1700W	TM / TC source	UMB(1) 125bps VCO	ENV simulator	closed loop
--------------	-----------	----------------	----------------------	---------------	-------------

(1) : to simplify the test, LGA1 RF link would be nominal

After an initial 15minute TM recording, the S/C shall be commanded to:

- 5kbps TM (Encoder in use, XPND in use),
- the subsampling disabled,
- and the TM downlink filter enlarged after §5.7.2.3 requirements.
- The TC uplink shall be set to 4kbps.

This shall allow to recover the success criteria data in a quicker way.

## 5.8.5.15. SAM to SM (deleted)

Deleted (no more SM mode SW command).

## 5.8.5.16. EAM to SM (deleted)

Deleted (no more SM mode SW command).

## 5.8.5.17. EAM to SAM (needs new SAM to NOM and NOM to EAM)

### 5.8.5.17.1. Preparatory tasks

- The same configuration that the one after the NOM to EAM test shall be rebuilt.
- The new SAM to NOM and NOM to EAM shall be run the same way as specified for the previous sequences §5.8.5.7 and §5.8.5.9 (§5.8.5.8 shall be skipped), managing the difference that the "in use" Tx chain is the chain B as the XPND 1 (Rx and Tx) is marked failed. The success criteria of the SAM to NOM and NOM to EAM shall be add the correct management of this degraded case (for example, the SM to SAM transition shall not trig a return on XPND 1). The Tx chain selection configuration shall be returned to full nominal for testing the EAM to SAM transition.
- The volunteer instrument shall be turned to HIFI (NOM to EAM) .

### 5.8.5.17.2. Transition sequence

The TC shall be sent to request the satellite to be set in SAM mode with the triad command.

- Set CIR relay, Set SAM mode (arm / fire), Set SCBP 5.

No ACMS command shall be sent.

#### **success criteria**

The satellite shall be set with default SAM configuration.

The final state shall be:



*Satellite state*

CDMS mode	SAM	note:		ACMS mode	SCM (QcIR)
TM/OBT	A	Rx rate	125bps	OBT, PM & SW	A1N [B1S] A
PM & SW	A1N [B1N]	TM rate	500bps	CRS / FDIR	1A, 2S/ AFO
SCBP / MTL	A-5 / Stopped	Tx chain	T.1 A.A LGA1	GYROs	A,B,C IF 1 ON
FDIR / SrvCBH	AFS / N only	Rx 1 Ant.	LGA1	STRs	A and B ON
launch straps	all separated	Rx 2 Ant.	MGA	RWs	OFF, LCL ON
PCDU IF / HPS	IF A / all N	CCU	A,B ON Hk	LV enable	A On B OFF
Battery	charged (BS)	SPIRE	STBY	RCS enable	A CBH-T ON
Power domain	SA	HIFI	STBY	SREM	ON
Mass Memory	(≥) 1 bank (no1)	PACS	STBY	VMC	OFF

*GSE support*

Power source	SAS 1475W	TM / TC source	UMB(1) 125bps VCO	ENV simulator	closed loop
--------------	-----------	----------------	-------------------	---------------	-------------

(1) : to simplify the test, LGA1 RF link would be nominal

The ACMS operation shall be unaffected.

The instrument operation shall have been again stopped and turned OFF.

The MTL operation shall still be disabled. The STR-2 state shall be OFF.

After an initial 15minute TM recording, the S/C shall be commanded to:

- 5kbps TM (Encoder in use, XPND in use),
- the subsampling disabled,
- and the TM downlink filter enlarged after §5.7.2.3 requirements,
- The TC uplink shall be set to 4kbps.

This shall allow to recover the success criteria data in a quicker way.

5.8.5.18. NOM to SAM (needs new SAM to NOM)

5.8.5.18.1. Preparatory tasks

- The same configuration that the one used for NOM to SM test shall be rebuilt (MTL, AFO, etc.).
- The volunteer instrument shall be turned to PACS in burst mode.

5.8.5.18.2. Transition sequence

The TC set shall be sent to request the satellite to be set in SAM mode (arm / fire).

- Set SAM mode, Set SCBP 5.

The ACMS command shall be sent according nominal for SAM transition procedure.

**success criteria**

The satellite shall be set with default SAM configuration.

The ACMS operating shall have search and found the SUN.

The instrument operation shall have been again stopped and turned OFF.

The MTL operation shall still be disabled.

The final state shall be:

*Satellite state*

CDMS mode	SAM	note:		ACMS mode	SAM (FN)
TM/OBT	A	Rx rate	125bps	OBT, PM & SW	A-A1N [B1S]
PM & SW	A1 [B1]	TM rate	500bps	CRS / FDIR	1A, 2S / AFS
SCBP / MTL	5 /Disabled	Tx chain	T.1 A.A LGA1	GYROs	A,B,C IF 1 ON
FDIR / SrvCBH	AFS / N only	Rx 1 Ant.	LGA1	STRs	A OFF B ON
launch straps	all separated	Rx 2 Ant.	MGA	RWs	OFF, LCL ON
PCDU / HPS	IF A / all N	CCU	A,B ON Hk	LV enable	ON, A open
Battery	charged (BS)	SPIRE	STBY	RCS enable	ON A CBH ON
Power Source	SA	HIFI	STBY	SREM	ON
Mass Memory	≥ 1 bank	PACS	STBY	VMC	OFF

## *GSE support*

Power source	SAS 1475W	TC source	UMB(1) 125bps VCO	ENV simulator	closed loop
--------------	-----------	-----------	----------------------	---------------	-------------

(1) : to simplify the test, LGA1 RF link would be nominal

After an initial 15minute TM recording, the S/C shall be commanded to:

- 5kbps TM (Encoder in use, XPND in use),
- the subsampling disabled,
- and the TM downlink filter enlarged after §5.7.2.3 requirements,
- The TC uplink shall be set to 4kbps.

This shall allow to recover the success criteria data in a quicker way.

### 5.8.5.19. Test end

The test end shall recover all the data stored inside the CDMS memory for post analysis.

The SAM mode may be used for this purpose.

The communication session may use nevertheless an increased TC and TM rate to reduce the data recovery time.

This sequence shall specifically include the dump of the CEL, SSMM and the RM log.

Note : small dump sessions (configuring only the TM encoder on 1.5Mps TM and getting data from the UMB I/F) may be inserted between the test sub-sequences , whenever it would be wished to make the sub-sequences more modular or independent.

(don't care)From this state, the satellite may be turned OFF or a new sequence may be started.

## 5.8.6. S/C RECONFIGURATION

**The objective of this sequence is to test the satellite for critical mode transition cases after a system level FDIR trigger.**

The test is conducted from the likely configuration of one S/C out of visibility, instrument running when relevant.

### 5.8.6.1. Test brief description

The test shall validate the S/C autonomous reconfiguration (level 3 and 4 alarms).

The test consider the generation of false alarms by:

- forcing software alarms from the special FDIR services TC (CDMS-TC(8,4,116,42) and ACMS-TC(8,1,206)) or,
- stimulating the DOD alarm.

In the way this specification is written, each step is defined to be run immediately following the previous one. More precisely, the configuration at entry of a step is defined by the configuration at output of the previous step.

But each sequence may be considered as independent with respect to the other if the test shall be stopped and resumed. A special care in chaining shall be brought upon the proper state of the RM registers after each sequence (as shall be done in the frame of a proper recovery).

Within each sequence, the activities are listed in a chronological order.

The following diagram depicts the CDMD and ACMS mode and state chaining along the full sequence (in bold red, are the CDMS transitions that are the subject of each sub-sequence).

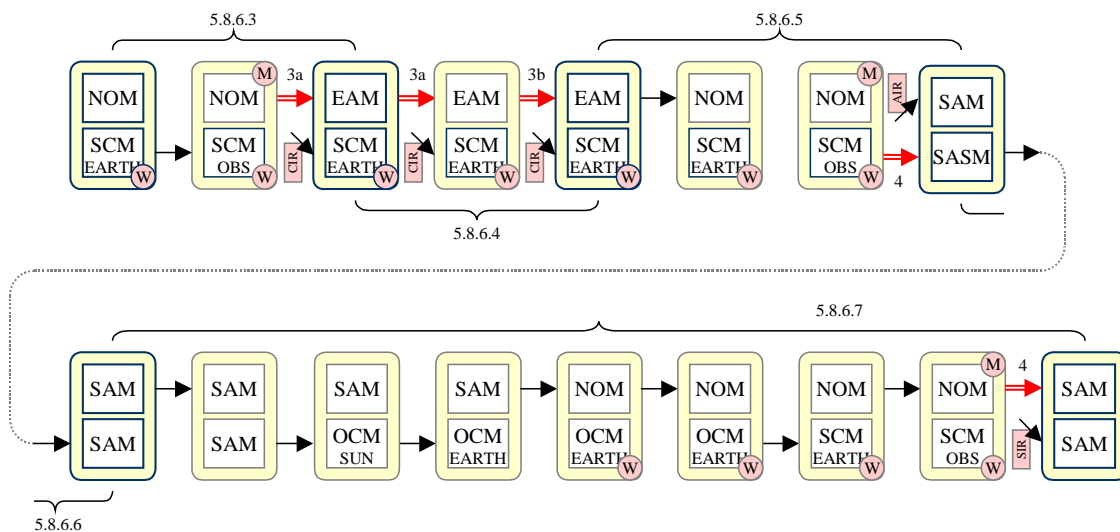

(dark bleu border steps are the one for which a satellite state table is given in the following chapters).

## 5.8.6.2. Test start configuration

The initial state shall simulate a satellite in a safe configuration in NOM Mode, Earth pointed.

Considering the "PM A1" "unit B" specified in details at §5.9.1, this initial state shall be:

### Satellite state

CDMS mode	NOM	note:		ACMS mode	SCM (Earth)
TM/OBT	B	Rx1 / Rx2 rate	125 / 4k	PM & SW & B	A1N [B1S] B
PM & SW	A1N [B1N]	TME / Tx rate	150kbps	CRS / FDIR	2A, 1S / AFO
SCBP / MTL	B-5 / Stopped	Tx chain	T.2 RF OFF	GYROs	A,B,D IF 1 ON
FDIR / SrvCBH	AFO / R only	Rx 1 Ant.	LGA1	STRs	B (A LCL ON)
launch straps	all separated	Rx 2 Ant.	MGA	RWs	1,2,4 ON
PCDU IF / HPS	IF B / all R	CCU	A,B ON Hk	LV	A OFF B ON
Battery	charged (BS)	SPIRE	STBY	THR	B CBH-T ON
Power domain	SA	HIFI	STBY	SREM	ON
Mass Memory	(≥) 1 bank (no2)	PACS	STBY	VMC	OFF

### GSE support

Power source	SAS 1475W	TM / TC source	UMB 4k VC1	ENV simulator	closed loop
--------------	-----------	----------------	------------	---------------	-------------

This state may be establish either from OFF state by general procedure, or from a previous test sequence through appropriate transitions.

- The mass memory shall be formatted with ≥1 bank.
- The SREM shall be ON as for routine satellite operation, but with a 60s (minimum) cycle setting for enhanced observability.
- The instrument shall be ON and running in STBY.
- The hypothesis for success criteria is that the CDMS and ACMS RM are in their default reset state, then that toggle delay will give the hand to RM-A to process the first alarm event, RM-B the second alarm event, etc.
- In turn, the survival registers (ACMS and CDMS) shall be adapted to the "unit B" configuration, that is inverted so that reconfigurations use "units A".

## 5.8.6.3. CDMS level 3a

### 5.8.6.3.1. Preparatory tasks

- the volunteer instrument HIFI shall be activated in PRIME mode (and generating science data).
- the MTL shall be activated, regularly issuing instrument and ACMS observation commands (typically around a point mid distance between Earth and Sun).
- NB. FDIR mode shall be AFO and SCBP shall be 2.

### 5.8.6.3.2. Transition sequence

A software alarm shall be generated from the special FDIR services TC CDMS-TC(8,4,116,42).

#### Success criteria

As a result of the alarm, the CDMS PM shall autonomously perform a reset, ending in the following state.

The spacecraft shall go in Earth Acquisition Mode as defined in AD03, Figure 2.3.3.

EAM Bus profile SCBP 1 shall be set.

TM shall be received 20s max after SW alarm command from the umbilical.

TM shall be received 200s max after SW alarm command from MGA.

The acquired TM packets shall not indicate any No-Go, not considering packet counter discontinuities.

All essential and non essential TM packets shall be available in real time TM after the TM lock is achieved, via the RF SCOE from the TTC chain B (XPND Tx 2 and TWTA B) considering inverted "unit B" configuration.

No event packet types (5,2) and (5,4) shall be generated.

The spacecraft units status shall be as in RD116, §6.3. (taking into account the PM A1 / unit B configuration).

ACMS shall be in SCM and point in the Earth direction in consistence with last TC\_update\_ephemerides command parameters loaded.

All the instrument shall be in stand-by.

The MTL software service shall be stopped.

The SREM shall still be ON, but its management software (BSW) shall be OFF (no TM observable).

The FDIR mode shall be AFS.

The CDMU RM Log shall indicate that the origin of the recovery has been a level3a SW alarm detection by RM-A (based on respect of the previous sequence, to be transpose in an another case).

This final state shall be:

# Herschel S/C IST specification

REFERENCE: H-P-2-ASP-SP-0939

DATE: December 20<sup>th</sup> 2007

ISSUE: 6.0

Page : 153

## Satellite state

CDMS mode	EAM	note:		ACMS mode	SCM (QCIR)
TM/OBT	B	Rx rate	125 / 4k	PM & SW & B	A1N [B1S] B
PM & SW	A1N [B1N]	TM rate	150kbps	CRS / FDIR	2A, 1S / AFO
SCBP / MTL	B-1 / stopped	Tx chain	T.2 A.B MGA	GYROs	A,B,D IF 1
FDIR / SrvCBH	AFS / R only	Rx 1 Ant.	LGA1	STRs	B (A LCL ON)
launch straps	all separated	Rx 2 Ant.	MGA	RWs	1,2, 4 ON
PCDU IF / HPS	IF B / all R	CCU	A,B ON Hk	LV	A OFF B ON
Battery	charged (BS)	SPIRE	STBY	THR	B CBH-T ON
Power domain	SA	HIFI	STBY	SREM	<b>ON (SW off)</b>
Mass Memory	(≥) 1 bank (no2)	PACS	STBY	VMC	OFF

## GSE support

Power source	SAS 1475W	TM / TC source	UMB / none	ENV simulator	closed loop
--------------	-----------	----------------	------------	---------------	-------------

## 5.8.6.4. *CDMS level 3b*

### 5.8.6.4.1. *Preparatory tasks for part 1*

- XPND Tx and TWTA shall be turned OFF by TC.
- The (redundant) STR-1 shall be turn ON (simulating a check out, STR shall be set tracking).
- The TM rate shall be turn to the high rate (1.5Mbps).
- The SREM software management shall be turn ON (60s cycle).
- Note : baseline is that S/C control is done through umbilical for those operations.

### 5.8.6.4.2. *Transition sequence part 1*

A software alarm shall be generated from the special FDIR services TC CDMS-TC(8,4,116,42).

#### **preliminary transition success criteria**

This shall result in a second level 3a conducted from RM-B this time (to be verified in RM log), a return in the exact starting condition except for STR-A (inverted unit).

This final state shall be:

#### *Satellite state*

CDMS mode	EAM	note:		ACMS mode	SCM (QCIR)
TM/OBT	B	Rx rate	125 / 4k	PM & SW & B	A1N [B1S] B
PM & SW	A1N [B1N]	TM rate	150kbps	CRS / FDIR	2A, 1S / AFO
SCBP / MTL	B-1 / stopped	Tx chain	T.2 A.B MGA	GYROs	A,B,D IF 1
FDIR / SrvCBH	AFS / R only	Rx 1 Ant.	LGA1	STRs	B and A ON
launch straps	all separated	Rx 2 Ant.	MGA	RWs	1,2, 4 ON
PCDU IF / HPS	IF B / all R	CCU	A,B ON Hk	LV	A OFF B ON
Battery	charged (BS)	SPIRE	STBY	THR	B CBH-T ON
Power domain	SA	HIFI	STBY	SREM	<b>ON (SW off)</b>
Mass Memory	(≥) 1 bank (no2)	PACS	STBY	VMC	OFF

#### *GSE support*

Power source	SAS 1475W	TM / TC source	UMB 4k VC1	ENV simulator	closed loop
--------------	-----------	----------------	------------	---------------	-------------



## 5.8.6.4.3. Preparatory tasks for part 2

s preparatory task, the previous altered configuration shall be rebuilt:

- Tx A and TWTA shall be turned OFF by TC.
- The TM rate shall be turn to the high rate (1.5Mbps).
- The SREM software management shall be turn ON (60s cycle).
- Note 1: baseline is that S/C control is done through umbilical for those operations.
- Note 2: this configuration is not representative of most likely 3b, but shall highlight the CDMS ASW actions.

## 5.8.6.4.4. Transition sequence part 2

A new software alarm shall be generated from the special FDIR services TC CDMS-TC(8,4,116,42).

### Success criteria

As a result of the alarm, the CDMS PM shall autonomously perform a reset, ending in exactly the same state as after part 1 except for CDMS PM switch over. The main points are detailed hereafter.

The CDMS shall have switched over to CDMS-PMB.

The spacecraft shall be in EAM as defined in AD03, Figure 2.3.3..

EAM Bus profile SCBP 1 shall be used.

TM shall be received 20s max after Reset is performed (to be seen from the umbilical).

TM shall be received 200s max after Reset (to be seen from MGA).

All the instrument shall be in stand-by.

The MTL software service shall be OFF.

The SREM shall still be ON, but its management software (BSW) shall be OFF.

The FDIR mode shall be AFS.

The acquired TM packets shall not indicate any No-Go, not considering packet counter discontinuities.

No event packet types (5,2) and (5,4) shall be generated.

ACMS shall be in SCM pointing to the Earth (QCIR).

The spacecraft units status shall be as in RD116, §6.4. (taking into account the PM A1 / unit B configuration).

The CDMU RM Log shall indicate that the origin of the recovery has been a level3b SW alarm detection by RM-A (based on respect of the previous sequence, to be transpose in an another case).

# Herschel S/C IST specification

REFERENCE: H-P-2-ASP-SP-0939

DATE: December 20<sup>th</sup> 2007

ISSUE: 6.0

Page : 156

The CDMS PM-B "nominal / survival" relay shall be still be in "nominal" position.

This final state shall be:

## Satellite state

CDMS mode	EAM	note:		ACMS mode	SCM (QCIR)
TM/OBT	B	Rx rate	125 / 4k	PM & SW & B	A1N [B1S] B
PM & SW	B1N [B1N]	TM rate	150kbps	CRS / FDIR	2A, 1S / AFO
SCBP / MTL	B-1 / stopped	Tx chain	T.2 A.B MGA	GYROs	A,B,D IF 1
FDIR / SrvCBH	AFS / R only	Rx 1 Ant.	LGA1	STRs	B and A ON
launch straps	all separated	Rx 2 Ant.	MGA	RWs	1,2, 4 ON
PCDU IF / HPS	IF B / all R	CCU	A,B ON Hk	LV	A OFF B ON
Battery	charged (BS)	SPIRE	STBY	THR	B CBH-T ON
Power domain	SA	HIFI	STBY	SREM	ON (SW off)
Mass Memory	(≥) 1 bank (no2)	PACS	STBY	VMC	OFF

## GSE support

Power source	SAS 1475W	TM / TC source	MGA VC1	ENV simulator	closed loop
--------------	-----------	----------------	---------	---------------	-------------

The RF link shall be acquired according §5.7.2.1 requirements to conduct the S/C operations, specifically the checks and RM log dumps.

## 5.8.6.5. ACMS level 4

### 5.8.6.5.1. Preparatory tasks

- Recall : the RF link shall be used to conduct the S/C operations.
- The S/C CDMS shall be configured for continuing operation on PM-B (this shall include RM PAP and survival register reprogramming, and the clearing of the attempt registers).
- Spacecraft shall be commanded back into the NOM mode configuration state.
- the volunteer instrument PACS shall be activated in PRIME mode (and generating science data), and an adapted MTL shall be started (and loaded if necessary)
- NB. FDIR mode shall be AFO and SCBP shall be 4.
- The S/C shall finally be turned in AP configuration i.e. TWTA and XPND RF output shall be commanded OFF.

The final state after all preparatory tasks shall be the following:

#### Satellite state

CDMS mode	NOM	note:		ACMS mode	SCM (OBS)
TM/OBT	B	Rx1 / Rx2 rate	125 / 4k	PM & SW & B	A1N [B1S] B
PM & SW	B1N [A1N]	TME / Tx rate	150kbps	CRS / FDIR	2A, 1S / AFO
SCBP / MTL	B-5 / Stopped	Tx chain	T.2 RF OFF	GYROs	A,B,D IF 1 ON
FDIR / SrvCBH	AFO / R only	Rx 1 Ant.	MGA	STRs	B and A ON
launch straps	all separated	Rx 2 Ant.	LGA1	RWs	1,2,4 ON
PCDU IF / HPS	IF B / all R	CCU	A,B ON Hk	LV	A OFF B ON
Battery	charged (BS)	SPIRE	STBY	RCS	B CBH-T ON
Power domain	SA	HIFI	STBY	SREM	ON
Mass Memory	(≥) 1 bank (no2)	PACS	PRIME	VMC	OFF

#### GSE support

Power source	SAS 1475W	TM / TC source	UMB / none	ENV simulator	closed loop
--------------	-----------	----------------	------------	---------------	-------------

## 5.8.6.5.2. *Transition sequence*

The following action shall be done:

Using the ACMS SCOE error injection function, the AAD stimulation shall be programmed to correspond to an angle which clearly violates the pointing domain. Note: the simulated S/C attitude shall be left unaffected, and only the AAD information shall be biased.

### **Success criteria**

SAM CDMS Mode (see AD03 Figure 2.3.3) shall be reached. SAM Bus profile shall be used.

The ACMS shall switch over to PM-B, and shall be in Survival Mode. Control and monitoring shall be based on the configuration programmed in the ACC Survival Context register indicated in RD04 §4.2.2.4. The RWL and the STR shall be OFF.

A subsampling of the essential TM packets shall be available in real time TM via the RF SCOE from the TTC chain B (taking into account "unit B" configuration).

The acquired TM packets shall not indicate any No-Go, not considering packet counter discontinuities.

No event packet types (5,2) and (5,4) shall be generated.

The spacecraft units status shall be as in RD116, §6.4 for all subsystem/instruments/units except RCS and ACMS and §6.5 for ACMS and RCS units.

SREM shall be ON and continue normal operation.

MTL shall be stopped.

The ACMS RM Log shall indicate that the origin of the recovery has been a level4 AAD alarm detection by RM-A (based on respect of the previous sequence, to be transposed in another case)

This final state shall be:

*Satellite state*

CDMS mode	SAM	note:		ACMS mode	SASM
TM/OBT	B	Rx1 / Rx2 rate	125bps	PM & SW & B	B1S [B1S] B
PM & SW	B1N [A1A]	TM rate	500bps	CRS / FDIR	1A, 2S / NA
SCBP / MTL	B-5 / stopped	Tx chain	T.2 A.B LGA1	GYROs	OFF (LCL ON)
FDIR / SrvCBH	AFS / R only	Rx 1 Ant.	MGA	STRs	OFF (LCL ON)
launch straps	all separated	Rx 2 Ant.	LGA1	RWs	OFF (LCL ON)
PCDU IF / HPS	IF B / all R	CCU	A,B ON Hk	LV	A ON B OFF
Battery	charged (BS)	SPIRE	STBY	THR	A CBH-T ON
Power domain	SA	HIFI	STBY	SREM	ON
Mass Memory	(≥) 1 bank (no2)	PACS	STBY	VMC	OFF

*GSE support*

Power source	SAS 1475W	TM / TC source	UMB / none	ENV simulator	closed loop
--------------	-----------	----------------	------------	---------------	-------------

After an initial 15minute TM recording, the S/C shall be commanded to:

- 5kbps TM (Encoder in use, XPND in use),
- the subsampling disabled,
- and the TM downlink filter enlarged after §5.7.2.3 requirements.
- The TC uplink shall be set to 4kbps.
- SAM low rate telemetry shall be enabled for generation.

This shall allow to recover the success criteria data in a quicker way.

## 5.8.6.6. ACMS recovery from Survival Mode (ACMS SASM to SAM)

### 5.8.6.6.1. Preparatory tasks

None.

### 5.8.6.6.2. Transition sequence

- Recovery activities shall be run from RF link in 4k / 5k enhanced observability condition.
- ACMS PAP table selection shall be changed to PMB nominal, PMA redundant.  
This operation shall be done one RM after the other, so that one only is disabled at a time.
- PMB bit 0 shall be set to "NOMINAL", PMA bit 0 shall be set to "SURVIVAL".
- Configuration in Use tables shall be updated so that nominal operation restart with branch A thrusters (i.e. no switch-over when returning to normal operation), and branch B shall be marked failed.

A reset ACC PM B command shall be sent.

#### **Success criteria**

Sun Acquisition Mode as defined in AD03, Figure 2.3.3 shall be obtained (taking into account "unit B" configuration).

The acquired TM packets shall not indicate any No-Go, not considering ACMS packet counter discontinuities.

CDMS and TTC RF operation shall undergo no perturbation.

No event packet types (5,2) and (5,4) shall be generated.

ACMS shall be in SAM on "B" side.

The spacecraft units status shall be as in RD116, §6.4 (taking into account "unit B" configuration).

# Herschel S/C IST specification

REFERENCE: H-P-2-ASP-SP-0939

DATE: December 20<sup>th</sup> 2007

ISSUE: 6.0

Page : 161

The final state shall be:

## Satellite state

CDMS mode	SAM	note:		ACMS mode	SAM
TM/OBT	B	Rx1 Rx2 rate	125 / 4k	PM & SW & B	B1N [A1S] B
PM & SW	B1N [A1N]	TME / Tx rate	5kbps	CRS /FDIR	1A, 2S / AFS
SCBP / MTL	B-5 / stopped	Tx chain	T.2 A.B LGA1	GYROs	A,B,D IF 1
FDIR / SrvCBH	AFS / N only	Rx 1 Ant.	MGA	STRs	OFF (LCL ON)
launch straps	all separated	Rx 2 Ant.	LGA1	RWs	OFF (LCL ON)
PCDU IF / HPS	IF B / all R	CCU	A,B ON HK	LV	A ON B OFF
Battery	charged (BS)	SPIRE	OFF	THR	A CBH-T ON
Power domain	SA	HIFI	OFF	SREM	ON
Mass Memory	(≥) 1 bank (no2)	PACS	OFF	VMC	OFF

## GSE support

Power source	SAS 1475W	TM / TC source	LGA1 VC1	ENV simulator	closed loop
--------------	-----------	----------------	----------	---------------	-------------

## 5.8.6.7. CDMS level 4

### 5.8.6.7.1. Preparatory tasks

- Spacecraft shall be commanded back into NOM configuration state.
- Redundant STR (1) shall be turned ON simulating a check out (tracking mode).
- the volunteer instrument PACS shall be activated in PRIME mode (and generating science data).
- NB. FDIR mode shall be AFO (for CDMS and ACMS) and SCBP shall be 4.
- MTL shall be activated, regularly issuing instrument and ACMS commands (around PT ½).
- the BS shall be set to simulate a low battery charge, yet above all the alarm thresholds.
- The S/C shall finally be turned in AP configuration i.e. TWTA and XPND RF output shall be commanded OFF.

The state after preparatory tasks shall be the following:

#### Satellite state

CDMS mode	NOM	note:		ACMS mode	SCM (OBS)
TM/OBT	B	Rx1 / Rx2 rate	125 / 4k	PM & SW & B	B1N [A1S] B
PM & SW	B1N [A1N]	TME / Tx rate	150kbps	CRS / FDIR	2A, 1S / AFO
SCBP / MTL	B-4 / running	Tx chain	T.2 RF OFF	GYROs	A,B,D IF 1 ON
FDIR / SrvCBH	AFO / R only	Rx 1 Ant.	MGA	STRs	B and A ON
launch straps	all separated	Rx 2 Ant.	LGA1	RWs	1,2,4 ON
PCDU IF / HPS	IF B / all R	CCU	A,B ON Hk	LV	A ON B OFF
Battery	charged (BS)	SPIRE	STBY	THR	A CBH-T ON
Power domain	SA	HIFI	STBY	SREM	ON
Mass Memory	(≥) 1 bank (no2)	PACS	PRIME	VMC	OFF

#### GSE support

Power source	SAS 1475W	TM / TC source	UMB / none	ENV simulator	closed loop
--------------	-----------	----------------	------------	---------------	-------------



## 5.8.6.7.2. Transition sequence

Then the following action shall be done:

1. Ramp down the Solar Array Simulator until this triggers the battery discharge at about 200W rate (the SAS shall not be abruptly reduced nor fully stopped in order not to create an abrupt bus collapse. For a similar reason, a large margin shall be kept on the battery mean delivered power to absorb transient peak demands (RW for example)). The applicable SAS setting shall be determined before the sequence run, from measured typical consumption of the test specimen in NOM mode).
2. Wait until triggering of DOD alarm (the waiting delay may be reduced by an action on the BS, but this action on the BS shall not create a perturbation on the S/C power bus operation).
3. Turn OFF the Solar Array Simulator, for 2 minutes, and then ramp it back ON to deliver 1700 Watts.

This last action shall trig a CDMS reset (reconfiguration).

### Success criteria

The CDMS shall have switched over back to CDMS-PM-A.

The CDMS shall be in Survival Mode (see AD03, Figure 2.3.3); spacecraft control shall be based on the configuration programmed in the CDMU Survival Context register indicated in RD04 §4.2.2.2. and modified in activities point 2. Survival Bus profile shall be used.

TM shall be received 20s max after DOD trigger is performed (to be seen from the umbilical).

TM shall be received 200s max after DOD trigger (to be seen from LGA1).

A subsampling of the essential TM packets shall be available in real time TM via the RF SCOE from the TTC chain B, Tx B and TWTA B not more than 3mn (EPC B pre heating time) after TM is lost.

The acquired TM packets shall not indicate any No-Go, not considering packet counter discontinuities.

The CDMU RM Log shall indicate that the origin of the recovery has been a DOD alarm detection by RM-B (based on respect of the previous sequence history, to be transposed in an another case).

As part of post analysis it shall be verified that the energy seek by the S/C during the reconfiguration, would have been compatible with the Battery state of charge not going below 20% at any test time (N.B. Battery Simulator does not simulate the battery charge / discharge dynamics).

No event packet types (5,2) and (5,4) shall be generated.

ACMS shall be in SAM.

The MTL software service shall be stopped.

The SREM and its management software service shall both be OFF.

All the non essential units shall have been turned OFF by the PCDU in answer to a DNELL command (see annexe 6 §14).

The spacecraft units status shall be as in RD116, §6.5 for all subsystems/instruments/units excepted ACMS units and §6.4 for ACMS units.

It shall be Verified that the ACMS limits cycles within the following boundaries :

# Herschel S/C IST specification

REFERENCE: H-P-2-ASP-SP-0939

DATE: December 20<sup>th</sup> 2007

ISSUE: 6.0

Page : 164

- satellites maintains the sun direction at less than 5° half cone from Z axis.
- the transient outside the attitude defined above, for more than 5 minutes, is less than 40° from YZ plane, and its projection onto YZ plane is less than 23° from Z.
- satellite rate is kept below 4 degrees/min .

The final state shall be:

## Satellite state

CDMS mode	SM	note:		ACMS mode	SAM
TM/OBT	A	Rx1 / Rx2 rate	125bps	PM & SW & B	B1N [A1S] A
PM & SW	A1S [A1S]	TME / Tx rate	500bps	CRS / FDIR	2A, 1S / AFS
SCBP / MTL	A-6 / stopped	Tx chain	T.1 A.A LGA1	GYROs	A,B,D IF 1 ON
FDIR / SrvCBH	AFS / N only	Rx 1 Ant.	LGA1	STRs	OFF (LCL ON)
launch straps	all separated	Rx 2 Ant.	LGA2	RWs	OFF (LCL ON)
PCDU IF / HPS	IF A / all N	CCU	A,B ON Hk	LV	A ON B OFF
Battery	>20% CHRg charging (BS)	SPIRE	OFF	THR	A CBH ON
Power domain	SA	HIFI	OFF	SREM	OFF
Mass Memory	(≥) 1 bank (no2)	PACS	OFF	VMC	OFF

## GSE support

Power source	SAS 1700W	TM / TC source	UMB / none	ENV simulator	closed loop
--------------	-----------	----------------	------------	---------------	-------------

After an initial 15minute TM recording, the S/C shall be commanded to:

- 5kbps TM (Encoder in use, XPND in use),
- the subsampling disabled,
- and the TM downlink filter enlarged after §5.7.2.3 requirements.
- The TC uplink shall be set to 4kbps.
- SCM low rate telemetry shall be disabled for generation.
- SAM low rate telemetry shall be enabled for generation.

This shall allow to recover the success criteria data in a quicker way.

## 5.8.6.8. Test end

The test end shall recover all the data stored inside the CDMS memory for post analysis.

The SM mode may be used for this purpose.

The communication session may use nevertheless an increased TC and TM rate to reduce the data recovery time.

This sequence shall specifically include the dump of the SSMM, CEL, ACMS event buffers and the CDMS and ACMS RM log.

Note : small dump sessions (configuring only the TM encoder on 1.5Mps TM and getting data from the UMB I/F) may be inserted between the test sub-sequences , whenever it would be wished to make the sub-sequences more modular or independent.

From this state, the satellite may be turned OFF or a new sequence may be started.

## 5.8.7. CDMS MANAGEMENT

### 5.8.7.1. Objective

---

The objective of this sequence is to test the non routine MTL, OBCP and SSMM management, that are not naturally experienced through the other sequences, as well as sample set of level 1 and level 2 FDIR cases.

---

### 5.8.7.2. Test requirements

#### 5.8.7.2.1. General sequence

The test shall simulate a standard DTCP session. The spacecraft shall be downloading recorded data.

The baseline shall be to use the DTCP no2 of the RMS (PACS OD) as a back-ground to this DTCP.

Note: this DTCP is normally "missed" in the RMS scenario, but this does not alter in any way the ESOC MTL to support an actual DTCP.

Note: see §5.8.9 RMS sequence test description for cross-references.

The baseline shall be that the SPIRE TC are removed from the previous OD ends of MTL, so that the DTCP begins with SPIRE simulated as "already" returned in STBY from earlier MTL commands. But SCBP shall be still be SPIRE one.

The SSMM packet stores shall be pre-filled before the test with enough data for requiring about 10 minutes of downlink at 1.5Mbps. The baseline may be to use PACS in burst mode during 1hour for that (i.e. there is no requirement to simulate SPIRE science data, despite the simulation considers a DTCP ending a SPIRE OD). A very high volume of data to be downlinked shall be simulated by repeating in loops the downlink the science store using a TC(15,9) with proper pointing settings. Except §5.8.7.2.4 and 5.8.7.2.5, the tests shall be performed with a packet store download in background.

The different operations specified in this sequence shall be classified as "ground led maintenance" with respect to the DTCP structure defined by §5.7.2.2.

WARNING : this is nevertheless not the case of §5.8.7.2.5 test, which shall be done in "AP" configuration, that is AFTER the end or BEFORE the beginning of DTCP itself.

The S/C shall be configured in "PM A2" unit A" configuration, as per details given in §5.9.1.

# Herschel S/C IST specification

REFERENCE: H-P-2-ASP-SP-0939

DATE: December 20<sup>th</sup> 2007

ISSUE: 6.0

Page : 167

The S/C state at the beginning of the DTCP period (just before TWTA turn ON) shall be the following.

## Satellite state

CDMS mode	NOM	note:		ACMS mode	SCM (OBS)
TM/OBT	A	Rx1 / Rx2 rate	4k / 125	PM & SW & B	A2N [B1S] A
PM & SW	A2N [B1N]	TM rate	150kbps	CRS / FDIR	1A, 2S / AFO
SCBP / MTL	A-3 / running	Tx chain	T.1 RF OFF	GYROs	A,B,C IF 1 ON
FDIR / SrvCBH	AFO / N only	Rx 1 Ant.	MGA	STRs	A (B LCL ON)
launch straps	all separated	Rx 2 Ant.	LGA1	RWs	1,2,3,4 ON
PCDU IF / HPS	IF A / all N	CCU	A,B ON HK	LV	A ON B OFF
Battery	charged	SPIRE	STBY	THR	A CBH-T ON
Power domain	SA	HIFI	STBY	SREM	ON
Mass Memory	1 bank (no1)	PACS	STBY	VMC	OFF

## GSE support

Power source	SAS	TM / TC source	UMB / none	ENV simulator	closed loop
--------------	-----	----------------	------------	---------------	-------------

The S/C state during the main part of the DTCP, that is as a result of MTL then ground actions shall be :

## Satellite state

CDMS mode	NOM	note:		ACMS mode	SCM (X)
TM/OBT	A	Rx1 / Rx2 rate	4k / 125	PM & SW & B	A2N [B1S] A
PM & SW	A2N [B1N]	TM rate	1.5Mbps	CRS / FDIR	1A, 2S / AFO
SCBP / MTL	A-X / running	Tx chain	T.1 A.A MGA(2)	GYROs	A,B,C IF 1 ON
FDIR / SrvCBH	AFO / N only	Rx 1 Ant.	MGA	STRs	A (B LCL ON)
launch straps	all separated	Rx 2 Ant.	LGA1	RWs	1,2,3,4 ON
PCDU IF / HPS	IF A / all N	CCU	A,B ON HK	LV	A ON B OFF
Battery	charged	SPIRE	STBY	THR	A CBH-T ON
Power domain	SA	HIFI	STBY	SREM	ON
Mass Memory	1 bank (noX)	PACS	X	VMC	OFF

## GSE support

Power source	SAS	TM / TC source	MGA / VCO	ENV simulator	closed loop
--------------	-----	----------------	-----------	---------------	-------------

Note (X) : change during the DTCP.

## 5.8.7.2.2. *MTL management*

The aim of the test is to experience the MTL management commands that shall be seldom used unless trouble with the operation. This concerns specifically:

- deleting individual MTL command,
- deleting MTL command in a time segment,
- inserting new MTL commands in the middle of an existing MTL,
- disabling / enabling MTL command set from their subschedule reference,
- disabling / enabling MTL commands set from their APID,
- etc.

The sequence shall be derived from §9.1.9 of CDMS SIT specification "On board scheduling".

## 5.8.7.2.3. *OBCP management*

The aim of the test is to experience also the OBCP management commands that shall be seldom used unless trouble with the operation. This concerns specifically:

- load, start, stop, suspend, resume from ground, delete and dump.

The baseline is to use an MTL extract of the Reference Mission Scenario to support the sequence.

The baseline for the OBCP exercise is :

- to use dummy OBCP, that will be used later to provide an additive "loading" on the DTCP worst case scenario sequence.
- to create an OBCP to replace a command sequence of the MTL, and the opposite (disabling of an OBCP).

The test sequence shall include the actual run of the MTL after its modification. The modification will so concern time tags in the hours that just follows the exercise.

## 5.8.7.2.4. *SSMM management*

The test shall also be used to support some seldom used packet store management commands:

- enable, disable, by Packet Store, Application ID, packet type...

As a basis that, an SSMM-A maintenance operation consisting in changing the active bank (1 bank configuration) from one bank to an other one (as if it current bank was presenting anomalies).

## 5.8.7.2.5. *FDIR level 1 and level 2*

The test shall be used also for testing the proper operation of the EAT and MOT function on sample cases:

- a failure inducing a spurious switching of one RF switch will be simulated by a CPDU direct command (MAP 0) at the beginning (or end) of the DTCP session.

- a failure inducing a spurious switching OFF of the active PCDU I/F will be simulated by a CPDU direct TC(2,1) command on the active I/F relay at the end of the DTCP session (last test).

Note : the failure shall be tested independently, that is the management of the previous failure simulation shall be ended before engaging a new one.

WARNING : the TWTA shall be yet or already OFF. Moving the RF-SW while the TWTA is ON may degrade the TWTA. This test shall be perform in AP configuration before or after the simulated DTCP period.

## Success criteria

RF switch failure : The direct command will act out of ASW knowledge then the MOT should detect an incoherence between the RF switch position and ASW statuses. MOT shall generate an event, that shall trig an FDIR corrective action.

PCDU I/F failure : The command will act out of SW knowledge then the SW (SCDB FDIR) should detect the I/F state (no RT answer), and trig an activation and switch over to I/F B.

### 5.8.7.2.6. *(transferred in §5.8.13)OBT management*

At the end of the test, an on board time update exercise will be performed, first forward in time, then backward. The time jump will represent a few seconds, but not an integer number. A 3.14s value may be used as a baseline.

The procedure will be run in nominal DTCP configuration (Earth pointed) with the 3 instrument in stand-by, but no SSMM or MTL activity. The test will be run after the sequence end (all other sequence data in SSMM recovered) just before running the OFF sequence.

The time update will be commanded from a CDMS-TC(9,10). The CDMS shall update its clock, and the instruments shall synchronise their clock automatically. The ACMS shall be synchronised then by a CDMS-TC(9,3) on its APID. The two CCU time shall be updated after that.

This time update (specifically with a non integer number of second) shall generate many troubles in the different software execution (SW cycle cut, process time trigger missed or delayed, etc.). The generation of many error events shall so be considered as nominal as part of this test. Such a procedure should never be nominal experienced in flight despite possible (time is correlated and corrected on ground). The test success will be restricted to the ability after a small time (possibly including some service of function reset) to recover a normal operation.

### 5.8.8. *DTCP WORST CASE SCENARIO*

#### 5.8.8.1. *Objective*

---

**The objective of this sequence is to test a DTCP scenario which combines the highest realistic number of parallel operations at the same time.**

---

This is not a saturation test in a way that the scenario shall remain a possible one with respect to nominal operation rules.

## 5.8.8.2. Test requirements

### *5.8.8.2.1. Background operation*

The test shall simulate a standard DTCP session.

The baseline shall be to use the DTCP no3 of the RMS (HIFI OD) as a back-ground to this DTCP.

Note: see §5.8.9 RMS sequence test description for cross-references.

The baseline shall be that the PACS TC are removed from the previous OD ends of MTL, so that the DTCP begins with PACS simulated as "already" returned in STBY from earlier MTL commands. But SCBP shall be still PACS one.

The SSMM packet stores shall be pre-filled before the test with enough data for requiring about 10 minutes of downlink at 1.5Mbps. The baseline may be to use PACS in burst mode during 1hour for that. A very high volume of data to be downlinked shall be simulated by repeating in loops the downlink the science store using a TC(15,9) with proper pointing settings. The packet store download simulation shall be so artificially extended to last until the end of the DTCP 1.5Mbps window.

The different operations specified in this sequence shall be classified as "ground led maintenance" with respect to the DTCP structure defined by §5.7.2.2.

The S/C shall be configured in "PM B2" "unit B" configuration, as per details given in §5.9.1.



# Herschel S/C IST specification

REFERENCE: H-P-2-ASP-SP-0939

DATE: December 20<sup>th</sup> 2007

ISSUE: 6.0

Page : 171

The S/C state at the beginning of the DTCP period (just before TWTA turn ON) shall be the following.

## Satellite state

CDMS mode	NOM	note:		ACMS mode	SCM (OBS)
TM/OBT	B	Rx1 / Rx2 rate	125 / 4k	PM & SW & B	B2N [A1S] B
PM & SW	B2N [A1N]	TM rate	150kbps	CRS / FDIR	2A, 1S / AFO
SCBP / MTL	B-4 / running	Tx chain	T.2 RF OFF	GYROs	A,B,C IF 1 ON
FDIR / SrvCBH	AFO / R only	Rx 1 Ant.	LGA1	STRs	B (B LCL ON)
launch straps	all separated	Rx 2 Ant.	MGA	RWs	1,2,3 ON
PCDU IF / HPS	IF B / all R	CCU	A,B ON HK	LV	A OFF B ON
Battery	charged	SPIRE	STBY	THR	B CBH-T ON
Power domain	SA	HIFI	STBY	SREM	ON
Mass Memory	1 banks (no2)	PACS	STBY	VMC	OFF

## GSE support

Power source	SAS	TM / TC source	UMB / none	ENV simulator	closed loop
--------------	-----	----------------	------------	---------------	-------------

The S/C state during the main part of the DTCP, that is as a result of MAL and ground actions shall be:

## Satellite state

CDMS mode	NOM	note:		ACMS mode	SCM (OBS)
TM/OBT	B	Rx1 / Rx2 rate	125 / 4k	PM & SW & B	B2N [B1S] B
PM & SW	B2N [A1N]	TM rate	1.5Mbps*	CRS / FDIR	2A, 1S / AFO
SCBP / MTL	B-4* / running*	Tx chain	T.2 A.B MGA	GYROs	A,B,C IF 1 ON
FDIR / SrvCBH	AFO / R only	Rx 1 Ant.	LGA1	STRs	B (B LCL ON)
launch straps	all separated	Rx 2 Ant.	MGA	RWs	1,2,3 ON
PCDU IF / HPS	IF B / all R	CCU	A,B ON HK	LV	A OFF B ON
Battery	charged	SPIRE	STBY*	THR	B CBH-T ON
Power domain	SA	HIFI	STBY*	SREM	ON
Mass Memory	1 banks (no2)	PACS	STBY*	VMC	OFF

## GSE support

Power source	SAS	TM / TC source	MGA / VC1	ENV simulator	closed loop
--------------	-----	----------------	-----------	---------------	-------------

Note (\*) : those fields are indeed affected by the individual tests run during the sequence..

## 5.8.8.2.2. *Specific requirements*

The test shall simulate a specifically loaded DTCP session. The spacecraft shall be downloading recorded data for about 3h of downlink at high rate. The scenario is a DTCP during which, some real time science is performed in parallel to the download (from MTL) (see RD06 for DTCP profile).

The test is concentrated during this DTCP part and shall superpose the following operation:

1. Science packet store data download,
2. Real time science, with the following details:
  - the real time science operation shall be run from the MTL,
  - the real time science operation shall be chosen to require many OBCP (instrument mode transition typically rely on OBCP),
  - the MTL shall request diagnostic packet from CDMS and ACMS at the same time,
  - the real time science TM shall be recorded in the SSMM,
3. Loading of the new MTL data at a high rhythm (up to 10TC "chunks" per second i.e. about 8.5 TC/s or more).
4. Upload of a full instrument dummy ASW image of about 1Mbyte shall be loaded in one of the instrument (being in STBY) as a background task. This upload shall be done in the instrument RAM area, so that this operation does not affect the instrument flight ASW image resident in EEPROM. This test shall only verify the ability to upload a large quantity of data toward an instrument (the upload result shall be verified, but there is no need to boot the instrument on this upload, which may be so, made of a simple test pattern).
5. Patch of one or two words in one "page" of the instrument ASW EEPROM, agreed and reserved for this test purpose. The test shall be repeated for the SPIRE and HIFI instruments (PACS does not support such a single/two word patch, but supports only full ASW image patches). This test shall only verify the ability to re-write the instrument EEPROM on a small sample case.

The baseline is to use an MTL extracted of the Reference Mission Scenario to support the sequence.

As part of this test, a SSMM download interrupt then resuming will be experience during VC3 dump, considering the following procedure:

- abort the SSMM download,
- request a packet store report,
- determine a proper time tag from which to resume the dump (i.e. from the store indexed entry just older than the latest downloaded packets),
- clear the SSMM from packet older than the time tag (read pointers are not updated in case of abort),
- resume the dump from that time tag.

Note that du to the way the SSMM pointers are managed, the abort / resume operation implies some overlap in the download, then it shall be considered as nominal that the CCS generate some alarm upon packet counter discontinuity and/or duplicated packet when the dump is resumed.

# Herschel S/C IST specification

REFERENCE: H-P-2-ASP-SP-0939

DATE: December 20<sup>th</sup> 2007

ISSUE: 6.0

Page : 173

---

This test may be appended with an another test to benefit from its configuration and already recorded MTL and stored SSMM data.

This test may be appended with an another test to benefit from its configuration and already recorded MTL and stored SSMM data. The test may be specifically combined with the MTL management test. The useful part of those both tests correspond to a small sequence in a full DTCP session.

## 5.8.9. REFERENCE MISSION SCENARIO

### 5.8.9.1. Objective

The objective of this sequence is to test the satellite during its nominal long term operation, especially comprising the scientific instruments operations.

It is organised around the Reference Mission Scenario (RMS RD02) which defines the activities to be carried out during a typical operational day.

### 5.8.9.2. Test start configuration

The initial state shall simulate a satellite in a AP L2 configuration performing science with PACS PRIME in STBY after a mode burst mode session.

This initial state shall be:

#### Satellite state

CDMS mode	NOM	note:		ACMS mode	SCM (OBS)
TM/OBT	A	Rx1 / Rx2 rate	4k / 125	PM & SW & B	A1N [B1S] A
PM & SW	A1N [B1N]	TM rate	150kbps	CRS / FDIR	1A, 2S / AFO
SCBP / MTL	A-4(1) / running	Tx chain	T.1 A.OFF MGA	GYROs	A,B,C IF 1 ON
FDIR / SrvCBH	AFO / N only	Rx 1 Ant.	MGA	STRs	A (B LCL ON)
launch straps	all separated	Rx 2 Ant.	LGA1	RWs	1,2,3,4 ON
PCDU IF / HPS	IF A / all N	CCU	A,B ON Hk	LV	A ON B OFF
Battery	charged	SPIRE	STBY	THR	A CBH-T ON
Power domain	SA	HIFI	STBY	SREM	ON
Mass Memory	3/1 banks	PACS	STBY (1)	VMC	OFF

#### GSE support

Power source	SAS	TM / TC source	UMB / none	ENV simulator	closed loop
--------------	-----	----------------	------------	---------------	-------------

(1) Note : typical state after a burst mode session.

PACS shall be turned in burst mode as early as possible to use the initialisation operation time to feed the SSMM with data. A 1 hour burst mode data recording shall be considered as a minimum. PACS shall be set back in stand-by and bus to regular PACS PRIME after this operation (note : RMS MTL starts after the point where the corresponding commands should be if those operation would have been part of a real AP "0" commanded by MTL). Note (1) in above S/C table illustrates those requirements.

A specific RMS test setting shall be to configure the SSMM-A in 3 bank configuration (no 0-1-2), but SSMM-B in 1 bank configuration (no 0) (note : applicable profiles are the standard 3 / 1 banks ones of appendix 4 §12 as for the other tests). As per nominal flight procedure, only the SSMM-A data shall be downlinked during DTCP. This means that, considering its reduced size, the SSMM-B packet store should saturate about mid course in the RMS duration, and operate in overwriting mode afterward (i.e. new data shall overwrite the oldest). This is an RMS objective that to observe the SSMM-B operating in this (flight representative) saturated condition. The warning events generated by the CDMS while reaching the saturation on SSMM-B (TM(5,2)) shall not be considered as a NO-GO, but a nominal behaviour in the context.

WARNING : it is recalled that this sequence shall be run using the flight battery (formal run only).

This state may be established either from OFF state by general procedure, or from a previous test sequence through appropriate transitions.

- The battery shall be fully charged.
- The SREM shall be ON as for routine satellite operation.
- The instrument shall be ON and running.
- the two CCU (A and B) shall be connected to the cryostat, (TBC-33 with ASED for the vents valves command plugs to be left disconnected from CCU to prevent a spurious activation). All cryostat monitoring will be so get through S/C TM for the duration of the test.
- The MTL that covers the 1<sup>st</sup> DTCP and 1 OD shall be pre-loaded, and running (see below).

### 5.8.9.3. Test steps

The sequence shall be organised to provide one 15h/16h OD test slot to each instrument: 12h/13h in autonomous condition with custom pointing, and 3h as part of the leading and trailing DTCP session. A short autonomous phase simulation is added at test beginning and end so that the DTCP 1 and 4 presents a complete DTCP profile.

The scenario shall include the simulation of a "missed" DTCP, i.e. a DTCP normally planned, but indeed not attended by the ground station after for example, bad weather conditions. DTCP no2 is this one. In such circumstance, the missed DTCP planned operations are reported on the next one, with so heavier than usual MTL upload and TM downlink operations (i.e. data volume about x 2). DTCP no2 is this one.

The following diagram illustrates the overall RMS organisation. Following table gives more details.

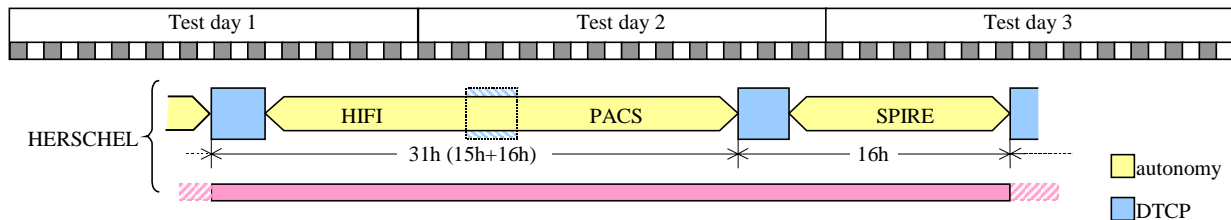

Step	simulated flight duration	Note
S/C turn on and initialisation		
SSMM pre-loading with PACS burst mode		MTL for next 5 steps is loaded
AP "0" end with PACS prime (introduction)	½h	Burst mode is used as a way to create quickly a minimum amount of TM data to be downlinked during DTCP no1.
DTCP 1 with switch over from PACS prime to SPIRE prime	3h	
AP 1 with HIFI prime	12h	
DTCP 2 with switch over from HIFI prime to PACS prime, and no ground contact established	3h	S/C is pointed to Earth and RF activated by MTL but no link is established. At end of the time slot, the DTCP is closed by the MTL which go on with next OD
AP 2 with PACS prime	13h	
DTCP 3 with switch over from PACS prime to SPIRE prime, and missed DTCP 2 compensation	3h	SSMM is dumped only partly of the over-accumulated VC3 data. A dummy MTL for 4 <sup>th</sup> OD is loaded.
AP 3 with SPIRE prime	13h	Photometer observation
DTCP 4 beginning with switch	3h	Test end with last TC from OD3 / OD4 UU (see note 1).

# Herschel S/C IST specification

REFERENCE: H-P-2-ASP-SP-0939

DATE: December 20<sup>th</sup> 2007

ISSUE: 6.0

Page : 177

over from SPIRE prime to SPIRE STBY, and continuation of missed DTCP 2 compensation if necessary.		
end of sequence		

Note: 1 OD (operational day) covers 1 DTCP and the AP (autonomous period) that follows. For instrument and MTL UU (upload unit), the operations are a few offset with respect to OD, and configuration begins nominally during previous DTCP, and ends during the following one.

The AP includes observation calling upon the slews, line scanning, raster scanning, peak-up (as applicable) and SRPE AOCS functions.

The detailed operations shall conform on the instrument side, the requirements of RD106 §4.6.3.2 (SPIRE) , §4.6.2.2 (PACS) and §4.6.4.2 (HIFI).

The sequence shall respect the generic requirements of §5.7, and specifically the ones concerning the DTCP task organisation §5.7.2.2.

Note : the RMS sequence DTCP include no specific "maintenance operation" (either ground or MTL led).

The instrument operation during the RMS shall be led from the MTL. The used UU files (Upload Unit = MTL loading command file covering a period going from one DTCP half point (approximately) to following DTCP "mid point") shall be the ones provided by ESOC for this test (they are prepared using the future flight operation tools).

The reference is an RMS sequence start at simulation date : May 18<sup>th</sup> 2008 12:43:00, with the DTCP of "OD080" (i.e. the RMS dates correspond to a working hypothesis of a 48h of routine operation at L2 after a launch around February 29<sup>th</sup> 2007).

The following diagram summarise the date conventions.

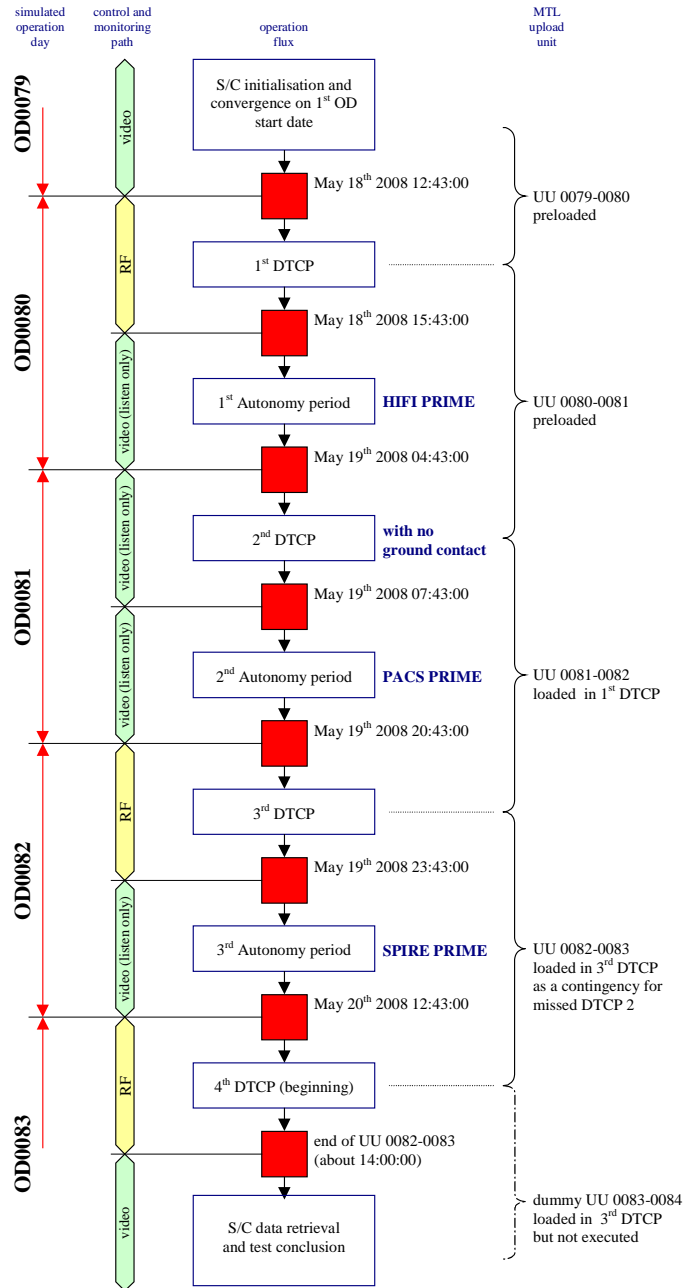

Note 1: HIFI RMS may not be run unless in final FM configuration. So ESOC provides a "SPIRE spectrometer" MTL that shall be used instead of HIFI one for debug (i.e. when HIFI may not be used).

Note 2: ESOC does not provide an actual UU 0083-0084 MTL. This one is indeed never executed. The base shall be to use as "UU 0083-0084" a copy of the "SPIRE spectrometer" UU 0082-0083 provided by ESOC for AVM tests, with a proper execution time tag translation.

Note 3: test end in the middle of DTCP no4 when last UU 0082-0083 TC has been released.

The S/C state during the AP periods shall be similar to the one specified §5.8.9.2 as starting configuration, with only the Instrument and SCPB state to be tailored as a function of the PRIME instrument.



# Herschel S/C IST specification

REFERENCE: H-P-2-ASP-SP-0939

DATE: December 20<sup>th</sup> 2007

ISSUE: 6.0

Page : 179

The S/C state at the beginning of the DTCP period, that is as a result of MTL actions shall be the following.

## Satellite state

CDMS mode	NOM	note:		ACMS mode	SCM (X)
TM/OBT	A	Rx1 / Rx2 rate	4k / 125	PM & SW & B	A1N [B1S] A
PM & SW	A1N [B1N]	TM rate	150kbps	CRS / FDIR	1A, 2S / AFO
SCBP / MTL	A-X / running	Tx chain	T.1 A.A MGA(1)	GYROs	A,B,C IF 1 ON
FDIR / SrvCBH	AFO / N only	Rx 1 Ant.	MGA	STRs	A (B LCL ON)
launch straps	all separated	Rx 2 Ant.	LGA1	RWs	1,2,3,4 ON
PCDU IF / HPS	IF A / all N	CCU	A,B ON HK	LV	A ON B OFF
Battery	charged	SPIRE	X	THR	A CBH-T ON
Power domain	SA	HIFI	X	SREM	ON
Mass Memory	3/1 banks	PACS	X	VMC	OFF

## GSE support

Power source	SAS	TM / TC source	UMB / none	ENV simulator	closed loop
--------------	-----	----------------	------------	---------------	-------------

The S/C state during the main part of the DTCP, that is as a result of ground actions shall be the following.

## Satellite state

CDMS mode	NOM	note:		ACMS mode	SCM (X)
TM/OBT	A	Rx1 / Rx2 rate	4k / 125	PM & SW & B	A1N [B1S] A
PM & SW	A1N [B1N]	TM rate	1.5Mbps	CRS / FDIR	1A, 2S / AFO
SCBP / MTL	A-X / running	Tx chain	T.1 A.A MGA(2)	GYROs	A,B,C IF 1 ON
FDIR / SrvCBH	AFO / N only	Rx 1 Ant.	MGA	STRs	A (B LCL ON)
launch straps	all separated	Rx 2 Ant.	LGA1	RWs	1,2,3,4 ON
PCDU IF / HPS	IF A / all N	CCU	A,B ON HK	LV	A ON B OFF
Battery	charged	SPIRE	X	THR	A CBH-T ON
Power domain	SA	HIFI	X	SREM	ON
Mass Memory	3/1 banks	PACS	X	VMC	OFF

## GSE support

Power source	SAS	TM / TC source	MGA / VCO	ENV simulator	closed loop
--------------	-----	----------------	-----------	---------------	-------------

Note (1) : ranging OFF coherent OFF. Note (2) : ranging OFF coherent ON.

Note (X) : those parameters vary from one DTCP to the next, and even during DTCP itself.

## 5.8.9.4. HIFI OD

The detailed program shall conform to RD106 §4.6.4.2.

## 5.8.9.5. PACS OD

The detailed program shall conform to RD106 §4.6.2.2.

## 5.8.9.6. SPIRE OD

The detailed program shall conform to RD106 §4.6.3.2.

## 5.8.9.7. Test end

The test end shall recover all the data stored inside the S/C memories for post analysis as per generic requirements.

The umbilical link may be used for this purpose.

This sequence shall specifically include the dump of the SSMM and the RM log.

*(useless)*

(integrated in previous paragraph, and no more back up needed)

## 5.8.9.8. Success criteria

The system and subsystem configuration shall be in accordance with the operations defined by the reference scenario.

The acquired TM packets shall not indicate any No-Go.

All essential, non essential and science TM packets shall be available in real time TM.

No event packet types (5,2) and (5,4) nor TC rejection packet shall be generated (except for TM(5,2) generated when the SSMM-B stores begin to saturates).

The spacecraft units status shall be as in RD116, §6.1.

The spacecraft pointing shall be consistent with MTL pointing targets and modes, with :

a- In inertial pointing Mode :

- Absolute Pointing Error LOS  $\leq 3.7$ arcsec
- APE around LOS = 3 arcmin

b- In scanning Mode :

- APE LOS  $\leq 3.7 + 0.05 \cdot \text{scan rate arcsec}$

Success criteria for instrument part of the test are defined by RD1 §6.

## 5.8.10. LAUNCH CLEAN RUN

### 5.8.10.1. Objective

**The objective of this sequence is to test that the umbilical connections do not bias or mask in a positive way, the satellite behaviour with respect to the real flight one.**

The test is limited by to the launch separation sequence. The test shall demonstrate that the satellite behaviour is strictly identical to the one recorded during the launch sequence until the lack of coherent close loop information stalls the ACMS.

### 5.8.10.2. Test brief description

The satellite is set in real flight configuration except that:

- the thrusters and the latch valve shall not be connected (resistive loads in test plugs),
- the antenna cap shall remain and be connected to the RF-SCOE,
- an optical raw SAS and AAD optical stimulation shall be installed (strong light in field of view). This stimulation shall prevent the immediate ARAD alarm trigger (AAD) and prevent the ACMS SW to branch into the Sun search contingency procedure (triggered when no valid Sun signal appears in any of the SAS field of views). The Sun aspect angle returned by the front SAS (-X) needs not to have a specific value while looking like a valid reading. The signal from the rear SAS (+Y) shall remain under Sun presence validity threshold (this should be the case in with ambient light, but a cover may be considered if not for sensor protection).
- the POWER SCOE shall be really configured as LPS.

All the signal passing through the umbilical shall be limited to the ones present on the launch pad. The other functions shall be physically disconnected (EGSE).

The launch preparation sequence shall be repeated as per launch sequence test (§5.8.2) , except that:

- the ACC "test data word bit 8" shall be configured as for flight (ACMS SCOE synchronisation message software sub-routine disabled).
- the TTC RF deliberate errors introduced in launch sequence test (§5.8.2) upon RFDN, Tx Rx rate and Rx rate, shall not be programmed, so that the configuration is actually the launch nominal one.
- the supply from the Solar Array is not activated (POWER SCOE SAS not available), and the test sequence continue thanks to the battery power.

At separation, all the two umbilical plugs shall be disconnected. Separation relays shall be set to separated just before the disconnection of the umbilical plugs to provide a representatively simultaneous disconnection of the plugs (baseline is manual disconnection of the two umbilical plugs by operators, so with a limited timing accuracy).

At separation + 200s, some observability (and emergency commandability) over the S/C shall be recovered from the RF link. But the satellite shall be left fully on itself.

Nominally, the S/C shall be acquired at nominal launch 4k/5kbps TM/TC configuration. This TM configuration may nevertheless switch after some minutes, as ACMS may try to reconfigure itself after being troubled -despite best effort- by limited sensor stimulation possibility in this specific test context. Such an ACMS reconfiguration, implies that an AIR signal is sent to the CDMS, leading to a TTC reconfiguration with 125/500bps parameters. Note: exact timing depends on SAS optical coarse stimulation, so is rather unpredictable. It is possible that the 4k/5k TM/TC configuration is not observed. It is possible that the 4k/5k TM/TC configuration is not observed (poor SAS stimulation). It is possible however that the 125/500 TM/TC configuration is not endured (perfect SAS stimulation), but test sequence shall be able to handle both cases.

RF link acquisition shall respect usual protocol as per §5.7.2.1 with 4k/5K TM/TC link first then 125/500..

After separation +10 minutes, the test shall be stopped by reconnecting the umbilical plugs. After reconnection, the umbilical TM communication and S/C power supply shall be re-established. Care shall be taken that the DFE SCOE does not support the hot plugging of the uplink TC signal. Then before connecting back the umbilical, the uplink TC signal line shall be disconnected at DFE output level. This implies specifically that the S/C turn OFF after this test sequence shall be conducted with TM from umbilical, and TC from RF. Care shall be also taken that separation straps are still open when reconnecting (if not, ACC RM will switch back to the launch PAP set, offering new reconfiguration possibility to the ACMS, which may disturb the S/C recovery operations).

This test is typically the last of the IST. The baseline is that the work of the almost complete satellite disconnection is combined with the need to move the satellite to the environment testing facilities.

WARNING : this sequence shall be run using the flight battery.

### 5.8.10.3. Success criteria

The system and subsystem configuration and behaviour shall be identical to the one recorded during the launch until ACMS fail to control the S/C.

The acquired TM packets shall not indicate any No-Go before separation +20s (ACMS attitude control actual start).

All essential, non essential and science TM packets shall be available in real time TM.

No event packet types (5,2) and (5,4) nor TC rejection packet shall be generated before separation +20s (ACMS attitude control actual start).

## 5.8.11. LAUNCH SEQUENCE ROBUSTNESS

### 5.8.11.1. Objective

The objective of this test is to demonstrate that the launch mode is robust to a trouble with a unit during ascent.

This sequence does not intend to be an overall verification, but only to sample the failure cases among the most critical. This concerns a level 4 failure at CDMS and ACMS level, as well as a trouble with the launch straps.

### 5.8.11.2. Test description

To limit the test time, the baseline is to re-run a launch sequence as per §5.8.2 with adding successive failure scenario during ascent and separation. This is more severe than any expected case (single point failure), but is acceptable by the design as long as the incident are not simultaneous.

The considered incident are the following:

- spurious CDMU PM A failure (simulated by a SW alarm TC),
- spurious ACC PM A failure (simulated by a SW alarm TC),
- launch strap 5 open too early (ACMS ASW consider itself separated, fail to operate (no thruster) leading to a reconfiguration, but WD enable relay position prevent entry to SASM until CDMS command those relay when it detect its own separation),
- launch strap 3 do not open (CDMSD RM-A-CCS 0 is blocked but RM-B shall back-up for that),

The launch sequence will shorten the preparation sequence with respect to §5.8.2 and will stop after correct stabilisation of the correct transition of the satellite in NOM mode.

The following diagram present the CDMS / ACMS mode state succession associated to the sequence:

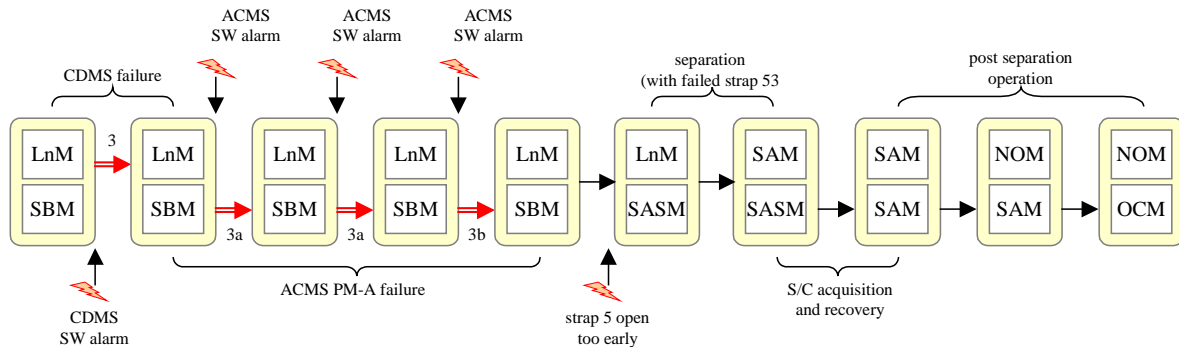

## 5.8.11.3. Test steps

### 5.8.11.3.1. General requirements

This step shall be identical to §5.8.2.4.1.

Note: specifically, as for §5.8.2, to work around the power SCOE inability to be operated both as LPS and SAS in the same test sequence, the baseline shall be that the LPS usage is simulated by supplying with the SAS, the 6 S/C sections cross-strapped to LPS umbilical inputs (i.e. PCDU section 26 to 30).

### 5.8.11.3.2. Satellite power ON

This step shall be identical to §5.8.2.4.2.

### 5.8.11.3.3. Short unit health check

This step shall be identical to §5.8.2.4.3.

### 5.8.11.3.4. Configuration for launch

This step shall be identical to §5.8.2.4.4. (including deliberate TTC configuration errors)

### 5.8.11.3.5. Configuration for launch

This step shall be basically identical to §5.8.2.4.5. but the successive incidents specified §9.5.2.1 shall be added, to form the following global timing:

- Lo-14' : power supply switching to battery (and shut down of TC uplink on UMB after latest control),
- Lo : supposed take off (no action),
- Lo+3' : CDMS software alarm (\*),
- Lo+3'46" : arming of V501 (N) & V503 (R) (dry loop command),
- Lo+3'46" : actuation (opening) of V501 (N) & V503 (R) (dry loop command),
- Lo+7' : 1<sup>st</sup> ACMS software alarm (\*), then 2<sup>nd</sup> and 3<sup>rd</sup> (as soon as ACMS is rebooted)
- Lo+15' : opening of launch strap n°5,
- Lo+17' : SAS ramp up to 580W (fairing opening),
- Lo+20'30" : actuation (opening) of V101 (N) & V106 (R) (dry loop command),
- Lo+20'40" : actuation (opening) of V101 (N) & V106 (R) (dry loop command),
- Lo+27' : separation from launcher with launch strap n°3 failing to open.

Note (\*) : the baseline is that the TC uplink on the umbilical is quickly re-activated to send the failure simulating TC, then shut down again.

The successive awaited satellite states are summarised below.

# Herschel S/C IST specification

REFERENCE: H-P-2-ASP-SP-0939

DATE: December 20<sup>th</sup> 2007

ISSUE: 6.0

Page : 186

## Satellite state : after **Lo, take off**

CDMS mode	LAUNCH	note:	RFDN all A	ACMS mode	SBM (presep)
TM/OBT	A	Rx1 / Rx2 rates	125 / 4k	PM & SW & B	A1N [B1S] A
PM & SW	A1N [B1N]	TME / Tx rates	5k / 150k	CRS / FDIR	1A, 2S / AFS
SCBP / MTL	A-0 / stopped	Tx chain	X1-ON Tx-OFF TWT1-OFF / LCL ON	GYROs	A,B,C IF 1
FDIR / SrvCBH	AFS / N only	XPND-1 Ant.	LGA1	STRs	OFF
launch straps	not separated	XPND-2 Ant.	LGA2	RWs	OFF
PCDU IF / HPS	IF A / all N	CCU	A,B ON 8s-Hk	LV	A & B OFF
Battery	> 70% SOC	SPIRE	OFF	THR	OFF
Domain	BAT	HIFI	OFF	SREM	OFF
Mass Memory	(≥) 1 bank (no0)	PACS	OFF	VMC	OFF

## GSE support

Power source	BS	TM / TC source	UMB / none	ENV simulator	stand-by
--------------	----	----------------	------------	---------------	----------

## Satellite state : after **Lo+3'+ CDMS switch-over delay**

CDMS mode	LAUNCH	note:	RFDN all A	ACMS mode	SBM (presep)
TM/OBT	A	Rx1 / Rx2 rates	<b>4k</b> / 4k bps	PM & SW & B	A1N [B1S] A
PM & SW	B1S [B1S]	TME / Tx rates	5k / <b>5k</b> bps	CRS / FDIR	1A, 2S / AFS
SCBP / MTL	A-0 / stopped	Tx chain	X1-ON Tx-OFF TWT1-OFF / LCL ON	GYROs	A,B,C IF 1
FDIR / SrvCBH	AFS / N only	XPND-1 Ant.	LGA1	STRs	OFF
launch straps	not separated	XPND-2 Ant.	LGA2	RWs	OFF
PCDU IF / HPS	IF A / all N	CCU	A,B ON 8s-Hk	LV	both closed both LCL OFF
Battery	> 70% SOC	SPIRE	OFF	THR	both LCL OFF
Domain	BAT	HIFI	OFF	SREM	OFF
Mass Memory	(≥) 1 bank (no0)	PACS	OFF	VMC	OFF

## GSE support

Power source	BS	TM / TC source	UMB / none	ENV simulator	stand-by
--------------	----	----------------	------------	---------------	----------



# Herschel S/C IST specification

REFERENCE: H-P-2-ASP-SP-0939

DATE: December 20<sup>th</sup> 2007

ISSUE: 6.0

Page : 187

*Satellite state : after Lo+ 7'+ 3 x ACMS reboot delays*

CDMS mode	LAUNCH	note:	RFDN all A	ACMS mode	SBSM (presep)
TM/OBT	A	Rx1 / Rx2 rates	4k bps	PM & SW & B	B1S [B1S] A
PM & SW	B1S [B1S]	TME / Tx rates	5k bps	CRS / FDIR	1A, 2S / AFS
SCBP / MTL	A-0 / stopped	Tx chain	X1-ON Tx-OFF TWT1-OFF / LCL ON	GYROs	A,B,C IF 1
FDIR / SrvCBH	AFS / N only	XPND-1 Ant.	LGA1	STRs	OFF
launch straps	not separated	XPND-2 Ant.	LGA2	RWs	OFF
PCDU	IF A	CCU	A,B ON 8s-Hk	LV	both closed both LCL OFF
Battery	> 70% SOC	SPIRE	OFF	THR	both LCL OFF
Domain	BAT	HIFI	OFF	SREM	OFF
Mass Memory	(≥) 1 bank (no0)	PACS	OFF	VMC	OFF

*GSE support*

Power source	BS	TM / TC source	UMB / none	ENV simulator	stand-by
--------------	----	----------------	------------	---------------	----------

*Satellite state : after Lo+ 15', spurious launch strap no5 opening + stabilisation delay*

CDMS mode	LAUNCH	note:	RFDN all A	ACMS mode	SBSM (presep)
TM/OBT	A	Rx1 / Rx2 rates	4k bps	PM & SW & B	B1S [B1S] A
PM & SW	B1S [B1S]	TME / Tx rates	5k bps	CRS / FDIR	1A, 2S / AFS
SCBP / MTL	A-0 / stopped	Tx chain	X1-ON Tx-OFF TWT1-OFF / LCL ON	GYROs	A,B,C IF 1
FDIR / SrvCBH	AFS / N only	XPND-1 Ant.	LGA1	STRs	OFF
launch straps	<b>no5 separated,</b> others not separated	XPND-2 Ant.	LGA2	RWs	OFF
PCDU IF / HPS	IF A / all N	CCU	A,B ON 8s-Hk	LV	both closed both LCL OFF
Battery	> 70% SOC	SPIRE	OFF	THR	both LCL OFF
Domain	BAT	HIFI	OFF	SREM	OFF
Mass Memory	(≥) 1 bank (no0)	PACS	OFF	VMC	OFF

*GSE support*

Power source	BS	TM / TC source	UMB / none	ENV simulator	stand-by
--------------	----	----------------	------------	---------------	----------

*Satellite state : after **Lo+27'**, just before seperation*

CDMS mode	LAUNCH	note:	RFDN all A	ACMS mode	SBSM (presep)
TM/OBT	A	Rx1 / Rx2 rates	4k bps	PM & SW & B	B1S [B1S] A
PM & SW	B1S [B1S]	TME / Tx rates	5k bps	CRS / FDIR	1A, 2S / AFS
SCBP / MTL	A-0 / stopped	Tx chain	X1-ON Tx-OFF TWT1-OFF / LCL ON	GYROs	OFF
FDIR / SrvCBH	AFS / N only	XPND-1 Ant.	LGA1	STRs	OFF
launch straps	no5 separated, others not separated	XPND-2 Ant.	LGA2	RWs	OFF
PCDU IF / HPS	IF A / all N	CCU	A,B ON 8s-Hk	LV	both closed both LCL OFF
Battery	> 70% SOC	SPIRE	OFF	THR	both LCL OFF
Domain	<b>SA+BAT</b>	HIFI	OFF	SREM	OFF
Mass Memory	(≥) 1 bank (no0)	PACS	OFF	VMC	OFF

*GSE support*

Power source	<b>SAS+BS</b>	TM / TC source	UMB / none	ENV simulator	stand-by
--------------	---------------	----------------	------------	---------------	----------

Complementary success criteria

The essential TM acquired during the sequence shall not indicate any No-Go.

No event packet types (5,2) (5,4) (1,2) (1,8) shall be generated.

Cryostat vent valves shall have opened in due time and shall still be opened.

### 5.8.11.3.6. Separation

This step shall be basically identical to §5.8.2.4.6. except that the separation switch no3 shall be left in "not separated" position, and ACMS is in SASM instead of SAM. Note : timing of ACMS transition to SASM is different from the SAM case.

Success criteria

For TTC, CDMS, PCS and Cryostat, the same criteria as for §5.8.2.4.6 apply (i.e. CDMU-PM switch-over remains quite transparent). CDMS RM log shall nevertheless attest that separation PAP has been run from RM-B (i.e. in back-up of RM-A nominal action, blocked by strap 5 failure).

For ACMS, the same criteria as for §5.8.2.4.6 apply. Configuration to do it shall be in turn fully different.

The final S/C status shall be the following.

*Satellite state : about 10 minutes after separation (full stabilisation)*

CDMS mode	<b>SAM</b>	note:	<b>RFDN all B</b>	ACMS mode	<b>SASM (sun)</b>
TM/OBT	A	Rx1 / Rx2 rates	4k bps	PM & SW & B	B1S [B1S] A
PM & SW	B1S [B1S]	TME / Tx rates	5k bps	CRS / FDIR	1A, 2S / AFS
SCBP / MTL	A-5 / stopped	Tx chain	T.1 A.1 LGA1	GYROs	OFF (LCL ON)
FDIR / SrvCBH	AFS / N only	XPND-1 Ant.	LGA1	STRs	OFF (LCL ON)
launch straps	all separated, except 3	XPND-2 Ant.	LGA2	RWs	OFF
PCDU IF / HPS	IF A / all N	CCU	A,B ON 8s-Hk	LV	<b>A OFF B ON</b>
Battery	<b>CHARGING</b> ( > 70% SOC)	SPIRE	OFF	THR	<b>B CBH-T ON</b>
Domain	<b>SA</b>	HIFI	OFF	SREM	OFF
Mass Memory	(≥) 1 bank (no0)	PACS	OFF	VMC	<b>ON image stored</b>

*GSE support*

Power source	SAS+BS	TM / TC source	UMB / none	ENV simulator	<b>close loop</b>
--------------	--------	----------------	------------	---------------	-------------------

### 5.8.11.3.7. S/C acquisition

This step shall be basically identical to §5.8.2.4.7. except that:

- ACMS command TC\_SET\_RCS\_CONTROL\_MODE = "fine" shall not be sent

Note (detail to be added in §5.8.2.4.7 in issue 4):

#### Success criteria

The same criteria as for §5.8.2.4.7, except for:

- SAM system mode after RD114 reference,
- ACMS fine performance control,
- detailed S/C status after RD116 reference,

which are not applicable in the context.

*Satellite state : after S/C RF acquisition*

CDMS mode	SAM	note:	RFDN all B	ACMS mode	SASM (sun)
TM/OBT	A	Rx1 / Rx2 rates	4k bps	PM & SW & B	B1S [B1S] A
PM & SW	B1S [B1S]	TME / Tx rates	5k bps <b>+RNG</b>	CRS / FDIR	1A, 2S / AFS
SCBP / MTL	A-5 / stopped	Tx chain	X1-ON Tx-ON TWT1-ON	GYROs	OFF (LCL ON)
FDIR / SrvCBH	AFS / N only	XPND-1 Ant.	LGA1	STRs	OFF (LCL ON)
launch straps	all separated, except 3	XPND-2 Ant.	LGA2	RWs	OFF
PCDU IF / HPS	IF A / all N	CCU	A,B ON 8s-Hk	LV	<b>A OFF B ON</b>
Battery	CHARGING ( > 70% SOC)	SPIRE	OFF	THR	<b>B CBH-T ON</b>
Domain	SA	HIFI	OFF	SREM	OFF
Mass Memory	(≥) 1 bank (no0)	PACS	OFF	VMC	ON

*GSE support*

Power source	SAS+BS	TM-TC source	<b>LGA1 VC0</b>	ENV simulator	close loop
--------------	--------	--------------	-----------------	---------------	------------

*5.8.11.3.8. Initial check out in SAM mode*

This step shall be basically similar to §5.8.2.4.7. except that:

TTC transition to 150kbps is not done,

ACMS check out shall be replace by running a SASM to SAM ACMS recovery (on basis of §5.8.6.6),  
the VMC data are to be recovered, but not downlinked in real time (5kbps does not allow it).

Note: the baseline of the test sequences is that the CDMS PM-A, ACMS PM-A and strap 3 are really failed.

The detailed operation is the following (title in bold highlight the standard recovery procedure point):

**ACMS and CDMS RM logs and CEL data shall be recovered**

TTC system check out,

- 1 > a TTC service 115 report shall be requested and cross check with as per §5.8.2.4.7.

TCS system check out,

- 1 > cross check as per §5.8.2.4.7 fully apply.

The telescope heating shall be activated.

- 1 > procedure as per §5.8.2.4.7 fully apply.

The CCU A and B shall be set to the nominal/default 512s sampling period.

- 1 > procedure as per §5.8.2.4.7 fully apply.

CDMS recovery (CDMS RM reconfiguration),

- 1 > RM log shall confirm that RM-A has not detected the separation, and indeed is always locked by the strap 5. RM log shall confirm that RM-B has operated properly (i.e. TWTA turn ON and THR switch ON is the prime indicator of that).

- 2 > one after the other, the 2 CDMS-RM shall be reprogrammed for "PM-B" healthy only operation.

ACMS recovery (global),

- 1 > one by one, the 2 ACMS-RM shall be reprogrammed for "PM-B" healthy only operation,

- 2 > the "Nominal" ACMS configuration shall be redefined for using THR branch B (i.e. the one used (ACMS service 141 function),

- 3 > the GYRO shall be turned ON and configured,

- 4 > the ACMS PM-B configuration relay 0 shall be switch from "survival" to "nominal".

# Herschel S/C IST specification

REFERENCE: H-P-2-ASP-SP-0939

DATE: December 20<sup>th</sup> 2007

ISSUE: 6.0

Page : 192

*Satellite state : before ACMS PM-B reset*

CDMS mode	SAM	note:	RFDN all B	ACMS mode	SASM (sun)
TM/OBT	A	Rx1 / Rx2 rates	4k bps	PM & SW & B	B1S [B1N]
PM & SW	B1S [B1S]	TME / Tx rates	5k bps <b>+RNG</b>	CRS / FDIR	1A, 2S / AFS
SCBP / MTL	A-5 / stopped	Tx chain	X1-ON Tx-ON TWT1-ON	GYROs	<b>1,2,3 IF 1</b>
FDIR / SrvCBH	AFS / N only	XPND-1 Ant.	LGA1	STRs	OFF (LCL ON)
launch straps	all separated, except 3	XPND-2 Ant.	LGA2	RWs	OFF
PCDU IF / HPS	IF A / all N	CCU	A,B ON Hk	LV	<b>A OFF B ON</b>
Battery	CHARGING ( > 70% SOC)	SPIRE	OFF	THR	<b>B CBH-T ON</b>
Domain	SA	HIFI	OFF	SREM	OFF
Mass Memory	(≥) 1 bank (no0)	PACS	OFF	VMC	ON

- 
- 5> the ACMS PM-B shall be reset : the ACMS shall reboot and re-establish in standard SAM mode

*Satellite state : after PM-B reset (and stabilisation time)*

CDMS mode	SAM	note:	RFDN all B	ACMS mode	<b>SAM (sun)</b>
TM/OBT	A	Rx1 / Rx2 rates	4k bps	PM & SW & B	B1N [B1N]
PM & SW	B1S [B1S]	TME / Tx rates	5k bps <b>+RNG</b>	CRS / FDIR	1A, 2S / AFS
SCBP / MTL	A-5 / stopped	Tx chain	X1-ON Tx-ON TWT1-ON	GYROs	1,2,3 IF 1
FDIR / SrvCBH	AFS / N only	XPND-1 Ant.	LGA1	STRs	OFF (LCL ON)
launch straps	all separated, except 3	XPND-2 Ant.	LGA2	RWs	OFF
PCDU IF / HPS	IF A / all N	CCU	A,B ON Hk	LV	<b>A ON B OFF</b>
Battery	CHARGING ( > 70% SOC)	SPIRE	OFF	THR	<b>A CBH-T ON</b>
Domain	SA	HIFI	OFF	SREM	OFF
Mass Memory	(≥) 1 bank (no0)	PACS	OFF	VMC	ON

6> as soon as ACMS boot report is received, the ACMS PM-B relay 0 shall be set back in "survival" position.

# Herschel S/C IST specification

REFERENCE: H-P-2-ASP-SP-0939

DATE: December 20<sup>th</sup> 2007

ISSUE: 6.0

Page : 193

*Satellite state :*

CDMS mode	SAM	note:	RFDN all B	ACMS mode	SAM (sun)
TM/OBT	A	Rx1 / Rx2 rates	4k bps	PM & SW & B	B1N [B1S]
PM & SW	B1S [B1S]	TME / Tx rates	5k bps <b>+RNG</b>	CRS / FDIR	1A, 2S / AFS
SCBP / MTL	A-5 / stopped	Tx chain	X1-ON Tx-ON TWT1-ON	GYROs	1,2,3 IF 1
FDIR / SrvCBH	AFS / N only	XPND-1 Ant.	LGA1	STRs	OFF (LCL ON)
launch straps	all separated, except 3	XPND-2 Ant.	LGA2	RWs	OFF
PCDU IF / HPS	IF A / all N	CCU	A,B ON Hk	LV	<b>A ON B OFF</b>
Battery	CHARGING ( > 70% SOC)	SPIRE	OFF	THR	<b>A CBH-T ON</b>
Domain	SA	HIFI	OFF	SREM	OFF
Mass Memory	(≥) 1 bank (no0)	PACS	OFF	VMC	ON

7> the ACMS SAM mode attitude shall be monitored for 10 minutes according the same criteria as for nominal post separation case §5.8.2.4.6 bullet "ACMS".

8> the ACMS shall then be commanded in fine mode (TC\_SET\_RCS\_CONTROL\_MODE = fine).

9> the same success criteria as for §5.8.2.4.7 bullet "S/C attitude" apply.

*Satellite state : after **PM-B reset (and stabilisation time)***

CDMS mode	SAM	note:	RFDN all B	ACMS mode	SAM (fine)
TM/OBT	A	Rx1 / Rx2 rates	4k bps	PM & SW & B	B1N [B1S]
PM & SW	B1S [B1S]	TME / Tx rates	5k bps <b>+RNG</b>	CRS / FDIR	1A, 2S / AFS
SCBP / MTL	A-5 / stopped	Tx chain	X1-ON Tx-ON TWT1-ON	GYROs	1,2,3 IF 1
FDIR / SrvCBH	AFS / N only	XPND-1 Ant.	LGA1	STRs	OFF (LCL ON)
launch straps	all separated, except 3	XPND-2 Ant.	LGA2	RWs	OFF
PCDU IF / HPS	IF A / all N	CCU	A,B ON Hk	LV	<b>A ON B OFF</b>
Battery	CHARGING ( > 70% SOC)	SPIRE	OFF	THR	<b>A CBH-T ON</b>
Domain	SA	HIFI	OFF	SREM	OFF
Mass Memory	(≥) 1 bank (no0)	PACS	OFF	VMC	ON

The VMC data shall be safeguarded and the unit turned OFF.

1 > procedure as per §5.8.2.4.7 fully apply, except that the TM(8,8) shall not be allowed for real time downlink (5kbps rate would not support this).

**Final success criteria**

The different success criteria defined for §5.8.2.4.8 apply, after above recovery actions.

The final considers in turn operations on ACMS and CDMS PM-B, the two PM-A being marked failed.

*Satellite state : end of initial check out in SAM mode, after degraded launch case*

CDMS mode	SAM	note:	RFDN all B	ACMS mode	SAM (fine)
TM/OBT	A	Rx1 / Rx2 rates	4k bps	PM & SW & B	B1N [B1S]
PM & SW	B1S [B1S]	TME / Tx rates	5k bps <b>+RNG</b>	CRS / FDIR	1A, 2S / AFS
SCBP / MTL	A-5 / stopped	Tx chain	X1-ON Tx-ON TWT1-ON	GYROs	1,2,3 IF 1
FDIR / SrvCBH	AFS / N only	XPND-1 Ant.	LGA1	STRs	OFF (LCL ON)
launch straps	all separated, except 3	XPND-2 Ant.	LGA2	RWs	OFF
PCDU IF / HPS	IF A / all N	CCU	A,B ON Hk	LV	<b>A ON B OFF</b>
Battery	CHARGING ( > 70% SOC)	SPIRE	OFF	THR	<b>A CBH-T ON</b>
Domain	SA	HIFI	OFF	SREM	OFF
Mass Memory	(≥) 1 bank (no0)	PACS	OFF	VMC	<b>OFF</b>

*GSE support*

Power source	SAS+BS	TM-TC source	<b>LGA1 VCO</b>	ENV simulator	close loop
--------------	--------	--------------	-----------------	---------------	------------

*5.8.11.3.9. Transition to NOM mode*

This step shall be identical to §5.8.2.4.9.

The additive success criteria, is that the fact that the spacecraft is operated on CMDS and ACMS PM-B, shall be transparent.

*5.8.11.3.10. Orbit Control Manoeuvre*

This step shall be identical to §5.8.2.4.10.

The additive success criteria, is that the fact that the spacecraft is operated on CMDS and ACMS PM-B, shall be transparent.



## 5.8.12. NOM MODE ROBUSTNESS

### 5.8.12.1. Objective

---

**The objective of this test is to demonstrate that the NOM mode is robust to a trouble with a communication problem between the sub-systems.**

---

The sequence does not intend to be an overall verification, but only to sample a couple of failure cases among the most critical : troubles with the CDMS 1553 bus. The two chosen scenarios affect simultaneously several sub-systems.

### 5.8.12.2. Test description

Two tests are consider to consider the two following scenarios:

- failure of the CDMS PM 1553 bus controller,
- failure of the ACC PM Remote Terminal.

The two cases simulate a failure occurring while the S/C is in NOM Mode, performing science at L2, in autonomy configuration (i.e. TWTA OFF, operation led by the MTL). The science operation shall be associated with a raster or line scan mode so that the incidents occurs while the ACMS is actively manoeuvring the S/C (note: such a context implies some level of synchronisation between the MTL and the incident triggering by the operators). To provide such a background, an RMS derived sequence or test MTL may be used.

The two cases shall be simulated by one of the following ways:

- CDMS BC (Bus Controller) failure simulation

The simultaneous loss of several RT shall be simulated. Such an event shall lead the CDMS FDIR to diagnostic a 1553 bus controller failure, then shall imply a CDMS reconfiguration (after several reset attempts) on the redundant PM as specified in SOFDIR annexe 1.

To provide such a simulationa jamming of the XPND and instrument 1553 addresses shall be created by programming the CDMU SCOE to provide also an answer (fixed messages) to the unit 1553 address interrogations. The superposition of the two answers shall render the different RT answer unreadable, making them appearing failed to the CDMU. To be effective however, the jamming shall start simultaneously on all RT. A 16s jamming shall be considered to produce a 3a, 3a, 3b reconfiguration sequence.

□ ACMS active PM RT (Remote Terminal) failure simulation

the 1553 ACC RT failure will be simulated by jamming the ACC 1553 address using the CDMU SCOE. The jamming shall be maintained until FDIR and reconfiguration stabilisation. This shall be checked at CDMU SCOE level, by the fact that neither N or R RT is anymore interrogated for more than 1 minute (cf. SOFDIR, FDIR consider several temporisation and retry steps)

The loss of the vital communication with the ACC shall imply a CDMS reconfiguration. This reconfiguration shall be associated with a delay before the restart of the communication with the ACMS (provided in case this one is also in reconfiguration). This delay will be used deactivate the CDMU SCOE jamming, so the communication cannot restart (consolidating the scenario). The ACC shall not reconfigure itself as it shall not consider an error at its own level, but shall react to the spacecraft in reconfiguration signal. The situation shall remain stable in SAM with no communication between the ACMS and CDMS until ground recovers manually the situation.

The tests shall include the satellite recovery from the ground (specifically in the second case).

The following diagram present the CDMS / ACMS mode state succession associated to the two concatenated sequences:

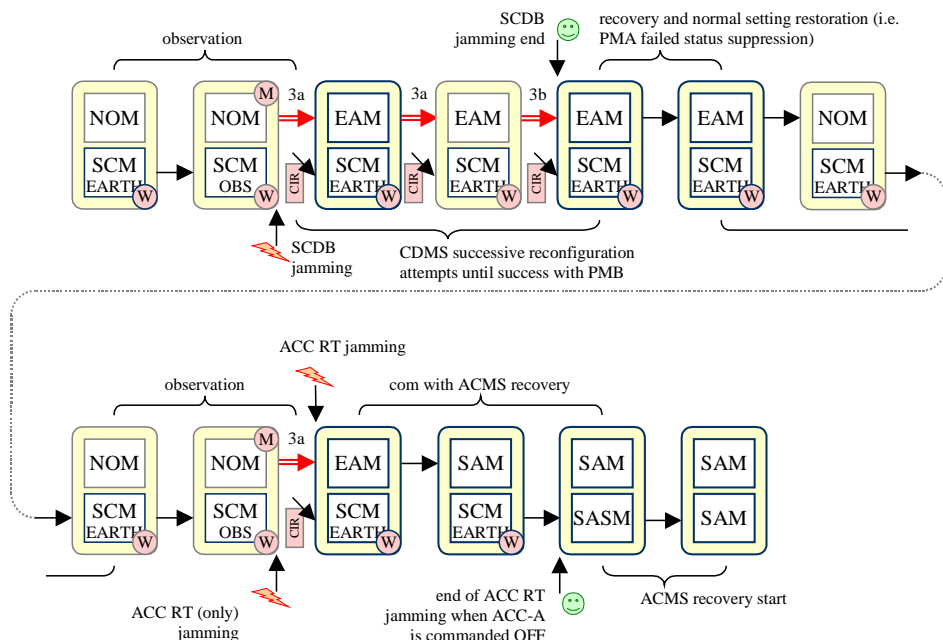

The two sequences shall be considered as independent if the test shall be stopped and resumed. A special care in chaining the two test shall be brought upon the proper state of the RM registers and RM log after each sequence (as shall be done in the frame of a proper recovery).

### 5.8.12.3. Test steps

#### 5.8.12.3.1. Initial state for first sub-sequence (Normal Science at L2, autonomy period)

The test sequence shall start with the S/C in NOM mode, performing science, in L2 autonomy configuration.

The prime instrument shall be SPIRE in photometer mode.

The configuration shall include S/C operation from MTL. The operation shall include the ACMS commanding into a raster or line scan operation. RMS SPIRE OD may be used as a back-ground.

As specified §5.9, the "NOM mode robustness sequence" shall be run in units B configuration. With respect to flight nominal/redundant unit usage, the allocation shall be "inverted" or "rotated" as per §5.9.2.

The global S/C status shall be the following.

*Satellite state : Normal science at L2 (autonomy period), SPIRE prime in photometer mode*

# Herschel S/C IST specification

REFERENCE: H-P-2-ASP-SP-0939

DATE: December 20<sup>th</sup> 2007

ISSUE: 6.0

Page : 198

CDMS mode	NOM	note:	RFDN BBAB	ACMS mode	SCM (scanning)
TM/OBT	B	Rx1 / Rx2 rates	125 / 4k	PM & SW & B	A1N [B1S] B
PM & SW	A1N [B1N]	TME / Tx rates	150kbps	CRS / FDIR	1A, 2S / AFO
SCBP / MTL	B-4 / running	Tx chain	T.2 RF OFF	GYROs	A,B,D IF1 ON
FDIR / SrvCBH	AFO / R only	XPND-1 Ant.	LGA1	STRs	2 ON
launch straps	all separated	XPND-2 Ant.	MGA	RWs	1,2,4 ON (⇒)
PCDU IF / HPS	IF B / all R	CCU	A,B ON Hk	LV	A OFF B ON
Battery	CHARGED (BS)	SPIRE	Photometer	THR	B CBH-T ON
Power domain	SA	HIFI	Stand-by	SREM	ON
Mass Memory	(≥) 1 bank (no3)	PACS	Stand-by	VMC	OFF

## GSE support

Power source	SAS 1475W	TM / TC source	UMB / none	ENV simulator	close loop
--------------	-----------	----------------	------------	---------------	------------

## 5.8.12.3.2. CDMS PM 1553 BC failure simulation

The CDMS PM 1553 BC failure shall be simulated by either (as safest and easiest):

Jamming the instruments and transponders RT.

The event shall lead the CDMS FDIR to consider a 1553 bus failure and to try first two successive 3a alarms.

### Success criteria

The event dynamics shall conform to SOFDIR requirements. But the mainlines shall be the following:

CDMS shall report through event messages, first communication problems with the jammed RT and attempt different recovery (specifically using bus A considering inverted "unit B" situation), then finally a software alarm.

CDMS shall then perform a level 3a reconfiguration (PM reset) led by RM-A. With the first software alarm, the ACMS shall so go to Earth pointing thanks to CIR signal.

As 1553 bus is still not operating, the CDMS 3a reconfiguration attempt shall fail, leading to a second attempt led by RM-B. The 3a reconfiguration failure may left the TTC chain in a quite an anomalous state.

The global S/C status at end of reboot transient shall be the following.

*Satellite state : end of the two 3a reconfiguration attempts (transient state)*

CDMS mode	EAM	note:	RFDN BBAB	ACMS mode	SCM (QCIR)
TM/OBT	B	Rx1 / Rx2 rates	125 / 4k	PM & SW & B	A1N [B1S] B
PM & SW	A1N [B1N]	TME / Tx rates	150kbps	CRS / FDIR	1A, 2S / AFO
SCBP / MTL	B-1 / <b>stopped</b>	Tx chain	<b>N/A (1)</b>	GYROs	A,B,D IF1 ON
FDIR / SrvCBH	<b>AFO</b> / R only	XPND-1 Ant.	LGA1	STRs	2 ON
launch straps	all separated	XPND-2 Ant.	MGA	RWs	1,2,4 ON
PCDU IF / HPS	IF B / all R	CCU	A,B ON Hk	LV	A OFF B ON
Battery	CHARGED (BS)	SPIRE	Photometer	THR	B CBH-T ON
Power domain	SA	HIFI	Stand-by	SREM	ON, SW OFF
Mass Memory	(≥) 1 bank (no3)	PACS	Stand-by	VMC	OFF

### GSE support

Power source	SAS 1475W	TM / TC source	UMB / none	ENV simulator	close loop
--------------	-----------	----------------	------------	---------------	------------

(1) As XPND is jammed, configuration shall failed, leaving the Tx chain in a state hardly predictable.

After the two failed 3a reconfiguration attempts, the CDMS shall try a 3b reconfiguration.

When observing the 3<sup>rd</sup> software alarm event, the 1553 bus operation shall be restored (reconnection or jamming stop).

The 3b reconfiguration shall succeed. Specifically:

the TTC chain shall be properly reconfigured (TWTA shall be ON),

SPIRE shall be turned to Stand-by mode (by OBCP),

the CDMS ASW and BSW health tables shall report the PM-A BC failure.

The global S/C status at end of 3b reconfiguration shall be the following.

*Satellite state : end of the 3b reconfiguration attempt (stable state)*

CDMS mode	EAM	note:	RFDN BBAB	ACMS mode	SCM ( <b>QCIR</b> )
TM/OBT	B	Rx1 / Rx2 rates	125 / 4k	PM & SW & B	A1N [B1S] B
PM & SW	<b>B1S</b> [B1S]	TME / Tx rates	150kbps	CRS / FDIR	1A, 2S / AFS
SCBP / MTL	B-1 / <b>stopped</b>	Tx chain	T.2 A.B MGA	GYROs	A,B,D IF1 ON
FDIR / SrvCBH	AFO / R only	XPND-1 Ant.	LGA1	STRs	2 ON
launch straps	all separated	XPND-2 Ant.	MGA	RWs	1,2,4 ON
PCDU IF / HPS	IF B / all R	CCU	A,B ON Hk	LV	A OFF B ON
Battery	CHARGED (BS)	SPIRE	Stand-by	THR	B CBH-T ON
Power domain	SA	HIFI	Stand-by	SREM	ON, SW OFF
Mass Memory	(≥) 1 bank (no3)	PACS	Stand-by	VMC	OFF

*GSE support*

Power source	SAS 1475W	TM / TC source	UMB / none	ENV simulator	close loop
--------------	-----------	----------------	------------	---------------	------------

SPIRE state shall be specifically cross checked.

Note: beside above real-time requirements, the overall reconfiguration dynamics will be cross checked in details from CEL, RM log and SSMM stored data as part of post analysis.

### 5.8.12.3.3. CDMS PM 1553 BC failure recovery

When the S/C configuration stable state is confirmed, the S/C control established via RF link, using standard acquisition procedure (to simulate a normal DTCP leading to the discovery of the anomaly).

Recovery operation shall be subsequently led through the RF link.

As for a failure analysis process, CEL, RM log and SSMM stored data (nominal and redundant data) shall be first downloaded.

Then CDMS configuration shall be re-organised as if PMA would be actually definitely failed. That is:

The two CDMS RM shall be reprogrammed with the PAP set for "PM-B only".

The PAP attempt counters shall be reset.

SREM software service shall be restarted.

CDMS shall be put back in NOM mode.

The MTL software service shall be restarted and the overall MTL contain deleted.

*Satellite state : end of the 3b reconfiguration attempt (stable state)*

CDMS mode	NOM	note:	RFDN BBAB	ACMS mode	SCM (OBS)
TM/OBT	B	Rx1 / Rx2 rates	125 / 4k	PM & SW & B	A1N [B1S] B
PM & SW	<b>B1N</b> [B1N]	TME / Tx rates	150kbps	CRS / FDIR	1A, 2S / AFS
SCBP / MTL	B-1 / <b>running</b>	Tx chain	T.2 A.B MGA	GYROs	A,B,D IF1 ON
FDIR / SrvCBH	AFO / R only	XPND-1 Ant.	LGA1	STRs	2 ON
launch straps	all separated	XPND-2 Ant.	MGA	RWs	1,2,4 ON
PCDU IF / HPS	IF B / all R	CCU	A,B ON Hk	LV	A OFF B ON
Battery	CHARGED (BS)	SPIRE	Stand-by	THR	B CBH-T ON
Power domain	SA	HIFI	Stand-by	SREM	ON
Mass Memory	(≥) 1 bank (no3)	PACS	Stand-by	VMC	OFF

*GSE support*

Power source	SAS 1475W	TM / TC source	UMB / none	ENV simulator	close loop
--------------	-----------	----------------	------------	---------------	------------

### 5.8.12.3.4. Initial state second test (Normal Science at L2, autonomy period)

The test shall restart the simulation of normal science in L2, in autonomy period configuration.

the prime instrument shall be PACS in photometer mode,

a new MTL reloaded, and operation from MTL restarted.

The S/C operation from MTL shall include the ACMS commanding into a raster or line scan operation. The RMS SPIRE OD may be used as a back-ground.

TX chain shall be turned OFF (typically from MTL) to finish the S/C configuration as for autonomous science operation.

The global S/C status shall be the following.

*Satellite state : Normal science at L2 (autonomy period), SPIRE prime in photometer mode*

CDMS mode	NOM	note:	RFDN BBAB	ACMS mode	SCM ( <b>QCIR</b> )
TM/OBT	B	Rx1 / Rx2 rates	125 / 4k	PM & SW & B	A1N [B1S] B
PM & SW	<b>B1N</b> [B1N]	TME / Tx rates	150kbps	CRS / FDIR	1A, 2S / AFS
SCBP / MTL	B-3 / <b>running</b>	Tx chain	T.2 RF OFF	GYROs	A,B,D IF1 ON
FDIR / SrvCBH	AFS / R only	XPND-1 Ant.	LGA1	STRs	2 ON
launch straps	all separated	XPND-2 Ant.	MGA	RWs	1,2,4 ON
PCDU IF / HPS	IF B / all R	CCU	A,B ON Hk	LV	A OFF B ON
Battery	CHARGED (BS)	SPIRE	Stand-by	THR	B CBH-T ON
Power domain	SA	HIFI	Stand-by	SREM	ON
Mass Memory	(≥) 1 bank (no3)	PACS	Photometer	VMC	OFF

### GSE support

Power source	SAS 1475W	TM / TC source	UMB / none	ENV simulator	close loop
--------------	-----------	----------------	------------	---------------	------------



## 5.8.12.3.5. ACMS 1553 RT failure simulation

The ACMS 1553 RT failure shall be simulated by:

Jamming the active ACMS RT.

The action shall lead the CDMS FDIR to try a 3a alarm (vital RT).

### Success criteria

CDMS shall report through event messages, communication problems with the ACMS, retry on 1553 bus B, then shall finally report a software alarm.

CDMS shall then perform a level 3a reconfiguration (PM reset). The ACMS shall so go to Earth pointing thanks to CIR signal (which shall be checked from ACMS SCOE pointing feed back data, as no TM will be available from ACMS as a consequence of the simulated failure and subsequent FDIR actions). As both ACMS RT shall be marked "invalid" after the FDIR, the CDMS shall maintain operation in EAM, despite not communicating with ACMS (ACMS RT shall not even been pooled after FDIR stabilisation).

As part of 3a alarm actions, it shall be specifically checked that :

MTL and SREM software services are OFF (i.e. have not restarted after boot),

PACS has been properly returned in stand-by by OBCP.

The global S/C status at end of reboot transient shall be the following (i.e. as no ACMS TM shall be available, ACMS entries are not all directly observable).

*Satellite state : end of the 3a reconfiguration attempt*

CDMS mode	EAM	note:	RFDN BBAB	ACMS mode	SCM (QCIR)
TM/OBT	B	Rx1 / Rx2 rates	125 / 4k	PM & SW & B	A1N [B1S] B
PM & SW	<b>B1N</b> [B1N]	TME / Tx rates	150kbps	CRS / FDIR	1A, 2S / AFS
SCBP / MTL	B-1 / <b>stopped</b>	Tx chain	T.2 A.B MGA	GYROs	A,B,D IF1 ON
FDIR / SrvCBH	<b>AFO</b> / R only	XPND-1 Ant.	LGA1	STRs	2 ON
launch straps	all separated	XPND-2 Ant.	MGA	RWs	1,2,4 ON
PCDU IF / HPS	IF B / all R	CCU	A,B ON Hk	LV	A OFF B ON
Battery	CHARGED (BS)	SPIRE	Stand-by	THR	B CBH-T ON
Power domain	SA	HIFI	Stand-by	SREM	ON, <b>SW OFF</b>
Mass Memory	(≥) 1 bank (no3)	PACS	<b>Stand-by</b>	VMC	OFF

*GSE support*

Power source	SAS 1475W	TM / TC source	UMB / none	ENV simulator	close loop
--------------	-----------	----------------	------------	---------------	------------

PACS state shall be specifically cross checked.

Note: beside above real-time requirements, the overall reconfiguration dynamics will be cross checked in details from CEL, RM log and SSMM stored data as part of post analysis.

As no telemetry from ACMS is available, the ACMS SCOE data (closed loop performance) shall be used as an indicator of ACMS proper operation.

### 5.8.12.3.6. ACMS 1553 RT failure recovery

When the S/C configuration stable state is confirmed, the S/C control established via RF link, using standard acquisition procedure (to simulate a normal DTCP leading to the discovery of the anomaly).

Recovery operation shall be subsequently led through the RF link.

As for a failure analysis process, CEL, RM log and SSMM stored data (nominal and redundant data) shall be first downloaded.

Then ACMS 1553 RT failure recovery considers a transition to PM-B in SASM, then SAM mode recovery.

As first step, the CDMS shall be returned in SAM mode. Specifically :

- The 3 instrument shall be turned OFF,
- The SREM operation shall be restarted,
- The 1553 bus profile shall be turned to profile 5.

Then CDMS shall be commanded in SAM mode (arm/fire), which shall specifically lead to TTC chain reconfiguration.

The global S/C status at end of reboot transient shall be the following.

*Satellite state : end of the 3b reconfiguration attempt (stable state)*

CDMS mode	SAM	note:	RFDN BAAB	ACMS mode	SCM (QCIR)
TM/OBT	B	Rx1 / Rx2 rates	<b>125bps</b>	PM & SW & B	A1N [B1S] B
PM & SW	<b>B1N</b> [B1N]	TME / Tx rates	<b>500bps</b>	CRS / FDIR	1A, 2S / AFS
SCBP / MTL	B-5 / <b>stopped</b>	Tx chain	T.2 A.B LGA1	GYROs	A,B,D IF1 ON
FDIR / SrvCBH	AFO / R only	XPND-1 Ant.	MGA	STRs	2 ON
launch straps	all separated	XPND-2 Ant.	LGA1	RWs	1,2,4 ON
PCDU IF / HPS	IF B / all R	CCU	A,B ON Hk	LV	A OFF B ON
Battery	CHARGED (BS)	SPIRE	<b>OFF</b>	THR	B CBH-T ON
Power domain	SA	HIFI	<b>OFF</b>	SREM	<b>ON</b>
Mass Memory	(≥) 1 bank (no3)	PACS	<b>OFF</b>	VMC	OFF

### GSE support

Power source	SAS 1475W	TM / TC source	LGA1 VC1	ENV simulator	close loop
--------------	-----------	----------------	----------	---------------	------------

TTC signal shall be re-acquired and transferred back to 4kbps / 5kbps configuration.

The ACMS transition to survival shall then be forced by acting directly on ACMS configuration relays (CDMS\_TC(2,1)):

Use PM B, PMB ON, Reset PM-B, PM-A OFF.

The 4 commands shall be sent in one block.

ACMS 1553 RT jamming shall be stopped from this point.

The above TC shall result in an ACMS reconfiguration in SASM.

The global S/C status at end of reboot transient shall be the following.

*Satellite state : end of the ACMS reconfiguration attempt (stable state)*

CDMS mode	SAM	note:	RFDN BAAB	ACMS mode	SASM
TM/OBT	B	Rx1 / Rx2 rates	125 / 4k	PM & SW & B	<b>B1S</b> [B1S] B
PM & SW	<b>B1N</b> [B1N]	TME / Tx rates	5Kbps	CRS / FDIR	1A, 2S / NA
SCBP / MTL	B-1 / <b>stopped</b>	Tx chain	T.2 A.B LGA1	GYROs	<b>OFF, LCL ON</b>
FDIR / SrvCBH	AFO / R only	XPND-1 Ant.	MGA	STRs	<b>OFF, LCL ON</b>
launch straps	all separated	XPND-2 Ant.	LGA1	RWs	<b>OFF, LCL ON</b>
PCDU IF / HPS	IF B / all R	CCU	A,B ON HK	LV	A ON B OFF
Battery	CHARGED (BS)	SPIRE	OFF	THR	A CBH-T ON
Power domain	SA	HIFI	OFF	SREM	ON
Mass Memory	(≥) 1 bank (no3)	PACS	OFF	VMC	OFF

*GSE support*

Power source	SAS 1475W	TM / TC source	LGA1 VC1	ENV simulator	close loop
--------------	-----------	----------------	----------	---------------	------------

From this point, the same procedure as specified in paragraph 5.8.6.6 apply to restore normal ACMS operation on PM-B only (ACMS PM-A shall be left marked failed).

# Herschel S/C IST specification

REFERENCE: H-P-2-ASP-SP-0939

DATE: December 20<sup>th</sup> 2007

ISSUE: 6.0

Page : 206

*Satellite state : end of the ACMS reconfiguration attempt (stable state)*

CDMS mode	SAM	note:	RFDN BAAB	ACMS mode	SAM
TM/OBT	B	Rx1 / Rx2 rates	125 / 4k	PM & SW & B	<b>B1N [B1S] B</b>
PM & SW	<b>B1N [B1N]</b>	TME / Tx rates	5Kbps	CRS / FDIR	1A, 2S / NA
SCBP / MTL	B-1 / <b>stopped</b>	Tx chain	T.2 A.B MGA	GYROs	<b>OFF, LCL ON</b>
FDIR / SrvCBH	AFO / R only	XPND-1 Ant.	MGA	STRs	<b>OFF, LCL ON</b>
launch straps	all separated	XPND-2 Ant.	LGA1	RWs	<b>OFF, LCL ON</b>
PCDU IF / HPS	IF B / all R	CCU	A,B ON Hk	LV	A ON B OFF
Battery	CHARGED (BS)	SPIRE	OFF	THR	A CBH-T ON
Power domain	SA	HIFI	OFF	SREM	ON
Mass Memory	(≥) 1 bank (no3)	PACS	OFF	VMC	OFF

*GSE support*

Power source	SAS 1475W	TM / TC source	LGA1 VC1	ENV simulator	close loop
--------------	-----------	----------------	----------	---------------	------------

## 5.8.13. TEST OF INSTRUMENT FDIR OBCP

### 5.8.13.1. Objective

The objective of the test is to test in an end to end way, each one of the instrument FDIR related CDMS OBCP. The test considers nevertheless only one of the trigger stimulation path when several exists.

Note: the "mode transition" OBCP are tested in the frame of the §5.8.5 "mode transition".

### 5.8.13.2. RD117 cross-reference

The instrument FDIR related CDMS OBCP may be classified in 3 categories as a function of the trigger chain:

- OBCP triggered from an instrument request : INST\_TM(5,x) > CDMS\_EAT > OBCP.
- OBCP triggered from a CDMS FDIR detected error : CDMS\_TM(5,x) > CDMS\_EAT > OBCP.
- OCCP triggered from a CDMS instrument monitoring : CDMS\_MOT > CDMS\_EAT > OBCP.

As per RD117, no instrument OBCP triggered by a CDMS instrument monitoring process is implemented for Herschel.

The CDMS FDIR detected instrument error cases, considers indeed SCBP transaction error management. An OBCP is defined for each instrument as a standard requirement, with respect to 3 cases:

- "DLL error", "TFL TC error" and "TFL TM" errors.

All the details shall be considered against RD117 information. Any discrepancy between this document and RD117, specifically the OBCP list in next chapter, shall be brought to the attention of the contractor for resolution.

### 5.8.13.3. Test requirements

The test of the instrument FDIR OBCP shall be performed with the S/C in "Autonomy Period" configuration (L2 routine operation) on the "PRIME" instrument. As part of this configuration, the PRIME instrument shall be performing a science measurement and the MTL shall be running. But a test MTL maybe used, and instrument configuration may not have been managed from the MTL so to have more flexibility to rebuilt the configuration to chain the test. The test MTL shall include some instrument commanding, but it may be limited to periodic "ping" (TC(17,1)).

The above reconfiguration shall be rebuilt before each OBCP individual test (i.e. test will alter this configuration).

The baseline shall be that AP that follows the §5.8.7 CDMS management, §5.8.8 DTCP worst case sequences, §5.8.9 RMS and §5.8.4.5.2 SPIRE commissioning complementary tests shall be used as starting point for the test. Those sequences shall end half of a shift with the S/C in the proper configuration (or near to for 5.8.4.5.2).

There is so no "PM" or "unit" requirement applicable for this test : as a matter of flexibility, will apply, the current S/C configuration of the test session to which each OBCP test will be appended.

Note: the OBCP operation rely on precise MTL design rules (subscedule ID usage). The background MTL use for the test shall be conform to those rules as defined by RD128 (i.e. this is applicable to any test anyhow).

The 1553 DLL FDIR (instrument RT failure) shall be simulated by programming the CDMU SCOE (1553 spy) to answer to the 1553 address of the instrument. The instrument answers to the CDMU are so jammed (and only those ones), which leads FDIR to generate the DLL event (instrument RT gives no intelligible answer) (i.e. this procedure is similar to the ones used for NOM mode robustness sequence).

The 1553 TM TFL FDIR (no TM from instrument), shall be simulated by sending to the instruments, a TC(14,2) "disable packet generation" for all Hk telemetry and stopping to send any command (including MTL pings). This shall cause the instrument to continue to properly answer at data link level (DLL) but to transmit no TM packet.

For the OBCP triggered from an instrument generated (only), the test procedure provided by the instrument team shall used. For example, SPIRE provides a test TC that allow to force the instrument to generate a specific event. The procedure is nevertheless left at instrument appreciation. Those procedures are managed by RD106 §4.6.6.

There is no requirement (unless instrument RD106 input), for performing the test on N rather than R instrument unit, and only one of the two configuration shall be tested. Baseline is that this shall be determined from the test sequence to which the OBCP test is appended.

### 5.8.13.4. SPIRE FDIR OBCP

The following table recall the different SPIRE OBCP, their different trigger source, and the ones (OBCP / trigger) that shall be tested as part of the sequence.

*SPIRE OBCP (extract from RD117 §4.1.3.1)*

part of test	OBCP	APID	TM	event ID	Comments
YES	DB_OBCP_H_SPIRE_DRCU_OFF	1280 1281	5,2	xC000	
YES	DB_OBCP_H_SPIRE_OPE_STOP			xC100	Test TC allow stimulation
YES	DB_OBCP_H_SPIRE_OPE_RESUME			xC110	Test TC allow stimulation
no	DB_OBCP_H_SPIRE_OFF	1280 1281	5,2	xC010	
YES no		16	5,x	152 171	DLL FDIR TFL TC FDIR

# Herschel S/C IST specification

REFERENCE: H-P-2-ASP-SP-0939

DATE: December 20<sup>th</sup> 2007

ISSUE: 6.0

Page : 209

YES	DB_OBCP_H_SPIRE_OFF_CTRL	16	5,x	185	TFL TM FDIR
no	DB_OBCP_H_SPIRE_STANDBY	transition to EAM or SAM			

## 5.8.13.5. PACS FDIR OBCP

The following table recall the different PACS OBCP, their different trigger source, and the ones (OBCP / trigger) that shall be tested as part of the sequence.

*PACS OBCP (extract from RD117 §4.2.3.1)*

part of test	OBCP	APID	TM	event ID	Comments
no	DB_OBCP_H_PACS_SAFE	1152 1153	5,2	4	
no		transition to EAM or SAM			
YES	DB_OBCP_H_PACS_BOLC_OFF	1152 1153	5,2	5	
YES	DB_OBCP_H_PACS_POWER_CYCLE			6	
no	DB_OBCP_H_PACS_IMMEDIATE_OFF	1152 1153	5,2	13	
YES		16			
no			172	TFL TC FDIR	
no				186	TFL TM FDIR
YES	DB_OBCP_H_PACS_IMMEDIATE_OFF	1152 1153	5,2	25	N or R don't care

## 5.8.13.6. HIFI FDIR OBCP

The following table recall the different HIFI OBCP, their different trigger source, and the ones (OBCP / trigger) that shall be tested as part of the sequence.

*HIFI OBCP (extract from RD117 §4.3.3.1)*

part of test	OBCP	APID	TM	event ID	Comments
YES	DB_OBCP_H_HIFI_RESET	16	5,x	151	DLL FDIR
no				170	TFL TC FDIR
no				184	TFL TM FDIR
no	DB_OBCP_H_HIFI_STANDBY	transition to EAM or SAM			

## 5.8.13.7. Success criteria

The FDIR OBCP considers simulation of failure conditions in order to test their proper management. In the context of those tests, error notification as TM(5,2) TM(5,4) and even possibly failed TC (TM(1,2) TM(1,8)) shall not be considered as NO-GO but direct or secondary effects of the test itself. It will be part of post analysis to check that the all reported events are expected in the detailed context of the test.

The test success criteria is that the TRIGGER + OBCP operation shall behave as defined by RD117 requirements for the related OBCP :

- SPIRE : RD117 §4.1.3.2,
- PACS : RD117 §4.2.3.2,
- HIFI : RD117 §4.3.3.2.

The nominal behaviour shall be assessed at CDMS level (specifically when CDMS actions are performed as MTL enabling / disabling), and Instrument level. That last point shall include a post analysis by the instrument team.

As a mater of principle, an instrument OBCP shall not affect the operation of the ACMS and other instrument (i.e. MTL level action shall affect only the instrument through proper usage of the APID and Subschedule enabling / disabling).



## 5.9. DEGRADED CASES

### 5.9.1. S/C ABILITY TO BE OPERATED IN DEGRADED MODES

#### 5.9.1.1. Objective

---

**The objective of this test is to demonstrate that all the redundancies which are implemented on the S/C are functional.**

---

This does not intend to be an overall verification, but only to sample the functionality of all the physical hardware units present on board.

#### 5.9.1.2. Test description

To limit the test time, the baseline is to run in fact, most test in a degraded configuration, by alternating the use of "A" units (nominal) and "B" units (degraded case).

To accelerate even further the test, the baseline is to switch between the nominal all "A" configuration with the :

- (ACC and CDMU) PM "B", all other units "A" configuration,
- (ACC and CDMU) PM "B", all other units "B" configuration,
- (ACC and CDMU) PM "A", all other units "B" configuration,

To manage separately the PM from the other units is necessary in order that the satellite operation rely successively on all the possible cross straps in the ACC and CDMU units. Additional cross straps (1553 busses specifically) and n / n+1 type redundancy exhaustive test imply nevertheless some more variations managed in some sequences. The applicable detailed sequence start configuration is specified in next chapter tables.

The global "alternative" configuration are not realistic with respect to flight. They would correspond to numerous failures at all levels. But the setting shall not disturb the proper satellite operation, and allow to go quickly with experiencing all the redundant hardware.

This sequence is so in fact merged with the other sequences.

As a baseline, the "PM" and "units" configuration may be fully random, as far as all the "A" and "B" units have been used effectively once during the IST.

It shall be noted that all the other sequence are presented with state tables which correspond to the all "A" nominal case. When use in "alternated" configuration, those table shall be transposed.

## 5.9.2. DETAILED TEST SEQUENCE START CONFIGURATION

The applicable test sequence start configuration is specified in next tables.

week	1	1	2	2
day	1	2	1	2
chapter	5.8.2	5.8.3	5.8.4.5	5.8.4.6
title	Launch	S/C commissioning	SPIRE commissioning	PACS commissioning
			deleted	
PM	A1	A1	A1	A1
Unit	A	AB	A	B
Bank	3	3	≥ 1	≥ 1
functional set	reconfiguration during the test sequence	no	yes	no
TRR	Hot supply	A+B	A+B	A+B
	RM	A+B	A+B	A+B
	PAP/CCS set (2)	PMA nominal	PMA nominal	PMA nominal
	CPDU	A+B	A+B	A+B
	SGM	A+B	A+B	A+B
	Survival Register	A+B	A+B	A+B
	Survival Register (2)	use B units	use B units	use B units
	OBT	A+B	A+B	A+B
	CRT (master OBT)	A	A	A
	TM Encoder	A	A	A
	TM/OBT for SM	B	B	B
TC decoder	A	B	A	
Nominal PM	PM			
	Cold supply	A	A	A
	SCDB ctrl			
	I/O IF (SBAH)			
	Boot mode	N	N	N
I/O	SW image	1	1	1
	SIO1			
	SIO2	all	all	all
SSMM	SIO3			
	SSMM ctrl	A+B	A+B	A+B
	SSMM banks	0-1-2	0-1-2	1
PM for SM	PM etc for SM	B	B	B
	Boot mode for SM	N	N	N
	SW Image for SM	1	1	1
CDMS 1553	SCDB	A	A	B
	SCDB used in SM	B	B	A
PCDU	1553 IF	A	A	A
	1553 for SM	B	B	B
	FCL and LCL	all	all	all
	BCR	1-2-3	1-2-3	1-2-3
	BDR	1-2	1-2	1-2
	HPS	A	A	A
	HES	(all groups)	(all groups)	(all groups)
	SA-shunts	all	all	all
	MEA	all	all	all
BAT	Cell columns	all	all	all
SA	SA Sections	all	all	all

# Herschel S/C IST specification

REFERENCE: H-P-2-ASP-SP-0939

DATE: December 20<sup>th</sup> 2007

ISSUE: 6.0

Page : 213

	chapter	5.8.2	5.8.3		5.8.4.5	5.8.4.6
	title	Launch	S/C commissioning		SPIRE commissioning	PACS commissioning
Rx	XPND-Rx	A+B	A+B		A+B	A+B
Tx chain	XPND-SDB-IF	A	A		A	B
	XPND-Tx					
	EPC					
	TWT					
Tx chain for SM	XPND-SDB-IF for SM	B	B		B	A
	XPND-Tx for SM					
	EPC for SM					
	TWT for SM					
RFND	RFND	1 and 3	1 and 3		1 and 3	2 and 4
	RFND pos in SM	BBBB	BBBB		BBBB	AABB
Antennas	MGA	LGA1	MGA		MGA	MGA
	LGA1					
	LGA2					
ARAD	ARAD	A+B	A+B		A+B	A+B
	ARAD used AAD	N	N		N	R
	ARAD used CRS	2	2		2	1
TRR	Hot supply	A+B	A+B		A+B	A+B
	RM	A+B	A+B		A+B	A+B
	PAP/CCS set (2)	PMA nominal	PMA nominal		PMA nominal	PMA nominal
	CPDU	A+B	A+B		A+B	A+B
	SGM	A+B	A+B		A+B	A+B
	Survival Register	A+B	A+B		A+B	A+B
	Survival Register (2)	use B units	use B units		use B units	use A units
	OBT	A+B	A+B		A+B	A+B
PM	PM	A	A		A	A
	Cold supply					
	SCDB ctrl					
	I/O IF (SBAH)					
	Boot mode					
SW image	1	1		1	1	
I/O	RIOH1	all	all		all	all
	RIOH2					
PM for SM	RCS I/F modules	A	A		A	B
	PM etc	B	B		B	B
	Boot mode	S	S		S	S
	SW Image	1	1		1	1
RCS branch for N operation	LV	A	A		A	B
	THR FCV/CBH					
RCS branch for SM	LV	B	B		B	A
	THR FCV/CBH for SM					
RCS support	Survival CBH for SM	N	N		N	R
	Pressure sensor	1 and 2	1 and 2		1 and 2	1 and 2
ACMS 1553	ACMS 1553	A	A		B	B
GYRO	IF E	1	1		1	1
	axe	A-B-C	A-B-C		A-B-C	B-C-D
STR	STR	A	A		A	B
RW	RW	N/A	1-2-3-4		1-2-3-4	2-3-4
CRS	CRS for SM	1	1		1	2
CCU	CCU	A and B	A and B		A and B	A
VMC	VMC	with	N/A		N/A	N/A
SREM	SREM	with	with		with	with
SPIRE	SPIRE	N/A	N/A		as per inst proc	as per inst proc
HIFI	HIFI	N/A	N/A		as per inst proc	as per inst proc
PACS	PACS	N/A	N/A		as per inst proc	as per inst proc

# Herschel S/C IST specification

REFERENCE: H-P-2-ASP-SP-0939

DATE: December 20<sup>th</sup> 2007

ISSUE: 6.0

Page : 214

**1** Those configurations need TBC that the unused units are marked failed (in the other cases, the baseline is

**B** Warning : specific setting with respect to strict PM / unit logic  
**A** Modified with resepect to previous spec issue

	week	2	2	3	3
	day	3	4	1	2
	chapter	5.8.4.7	5.8.4.8	5.8.5	5.8.6 5.9.3
	title	HIFI commisioning	PARALLEL MODE commisioning	Mode transition	Reconfiguration MON Mode robustness
	PM	B1	B1	A1	AB1
	Unit	A	B	A	B
	Bank	≥ 1	≥ 1	≥ 1	≥ 1 ≥ 1
functional set	reconfiguration during the test sequence	no	no	yes	yes yes
TRR	Hot supply	A+B	A+B	A+B	A+B A+B
	RM	A+B	A+B	A+B	A+B A+B
	PAP/CCS set (2)	PMB nominal	PMB nominal	PMA nominal	PMA nominal PMA nominal
	CPDU	A+B	A+B	A+B	A+B A+B
	SGM	A+B	A+B	A+B	A+B A+B
	Survival Register	A+B	A+B	A+B	A+B A+B
	Survival Register (2)	use B units	use A units	use B units	use A unit use A units
	OBT	A+B	A+B	A+B	A+B A+B
	CRT (master OBT)	A	B	A	B B
	TM Encoder	B	A	B	A A
TM/OBT for SM	B	A	B	A A	
TC decoder	A	B	A	B B	
Nominal PM	PM				
	Cold supply	B	B	A	A A
	SCDB ctrl				
	I/O IF (SBAH)				
	Boot mode	N	N	N	N N
SW image	1	1	1	1 1	
I/O	SIO1				
	SIO2	all	all	all	all all
	SIO3				
SSMM	SSMM ctrl	A+B	A+B	A+B	A+B A+B
	SSMM banks	3	0	1	2 3
PM for SM	PM etc for SM	A	A	B	B B
	Boot mode for SM	N	N	N	N N
	SW Image for SM	1	1	1	1 1
CDMS 1553	SCDB	A	A	A	B B
	SCDB used in SM	B	B	B	A A
PCDU	1553 IF	A	B	A	B B
	1553 for SM	B	A	B	A A
	FCL and LCL	all	all	all	all all
	BCR	1-2-3	1-2-3	1-2-3	1-2-3 1-2-3
	BDR	1-2	1-2	1-2	1-2 1-2
	HPS	A	B	A	B B
	HES	(all groups)	(all groups)	(all groups)	(all groups) (all groups)
	SA-shunts	all	all	all	all all
MEAs	all	all	all	all all	
BAT	Cell columns	all	all	all	all all
SA	SA Sections	all	all	all	all all

# Herschel S/C IST specification

REFERENCE: H-P-2-ASP-SP-0939

DATE: December 20<sup>th</sup> 2007

ISSUE: 6.0

Page : 215

	chapter	5.8.4.7	5.8.4.8	5.8.5	5.8.6	5.9.3
	title	HIFI commisioning	PARALLEL MODE commisioning	Mode transition	Reconfiguration	MON Mode robustness
Rx	XPND-Rx	A+B	A+B	A+B	A+B	A+B
Tx chain	XPND-SDB-IF	A	B	A	B	B
	XPND-Tx					
	EPC					
	TWT					
Tx chain for SM	XPND-SDB-IF for SM	B	A	B	A	A
	XPND-Tx for SM					
	EPC for SM					
	TWT for SM					
RFND	RFND	1 and 3	2 and 4	1 and 3	2 and 4	2 and 4
	RFND pos in SM	BBBB	AABB	BBBB	AABB	AABB
Antennas	MGA	MGA	MGA	MGA	MGA	MGA
	LGA1					
	LGA2					
ARAD	ARAD	A+B	A+B	A+B	A+B	A+B
	ARAD used AAD	N	R	N	R	R
	ARAD used CRS	2	1	2	1	1
TRR	Hot supply	A+B	A+B	A+B	A+B	A+B
	RM	A+B	A+B	A+B	A+B	A+B
	PAP/CCS set (2)	PMB nominal	PMB nominal	PMA nominal	PMA nominal	PMA nominal
	CPDU	A+B	A+B	A+B	A+B	A+B
	SGM	A+B	A+B	A+B	A+B	A+B
	Survival Register	A+B	A+B	A+B	A+B	A+B
	Survival Register (2)	use B units	use A units	use B units	use A unit	use A units
	OBT	A+B	A+B	A+B	A+B	A+B
PM	PM	B	B	A	A	A
	Cold supply					
	SCDB ctrl					
	I/O IF (SBAH)					
I/O	Boot mode	N	N	N	N	N
	SW image	1	1	1	1	1
	RIOH1 RIOH2	all	all	all	all	all
PM for SM	RCS I/F modules	A	B	A	B	B
	PM etc	A	A	B	B	B
	Boot mode	S	S	S	S	S
	SW Image	1	1	1	1	1
RCS branch for N operation	LV	A	B	A	B	B
	THR FCV/CBH					
RCS branch for SM	LV	B	A	B	A	A
	THR FCV/CBH for SM					
RCS support	Survival CBH for SM	N	R	N	R	R
	Pressure sensor	1 and 2	1 and 2	1 and 2	1 and 2	1 and 2
ACMS 1553	ACMS 1553	A	A	A	B	B
GYRO	IF E	1	1	1	1	1
	axe	A-B-C	A-C-D	A-B-C	A-B-D	A-B-D
STR	STR	A	B	A	B	B
RW	RW	1-2-3-4	1-3-4	1-2-3-4	1-2-4	1-2-4
CRS	CRS for SM	1	2	1	2	2
CCU	CCU	A and B	B	A and B	A and B	A and B
VMC	VMC	N/A	N/A	N/A	N/A	N/A
SREM	SREM	with	with	with	with	with
SPIRE	SPIRE	as per inst proc	as per inst proc	A	A	A
HIFI	HIFI	as per inst proc	as per inst proc	A	A	A
PACS	PACS	as per inst proc	as per inst proc	A	A	A

# Herschel S/C IST specification

REFERENCE: H-P-2-ASP-SP-0939

DATE: December 20<sup>th</sup> 2007

ISSUE: 6.0

Page : 216

	week	3	3	3	4	3
	day	3	5	6	1-2-3	5
	chapter	5.8.5	5.8.7	5.8.8	5.8.9	5.8.10
	title	Launch Mode robustness	CDMS management	DTCP Worst Case scenario	RMS	Launch Clean Run
	PM	AB1	A2	B2	AB1	A1
	Unit	A	A	B	A	A
	Bank	≥ 1	≥ 1	≥ 1	3	3
functional set	reconfiguration during the test sequence	yes	yes	no	no	no
TRR	Hot supply	A+B	A+B	A+B	A+B	A+B
	RM	A+B	A+B	A+B	A+B	A+B
	PAP/CCS set (2)	<i>PMA nominal</i>	<i>PMA nominal</i>	<i>PMB nominal</i>	<i>PMA nominal</i>	<i>PMA nominal</i>
	CPDU	A+B	A+B	A+B	A+B	A+B
	SGM	A+B	A+B	A+B	A+B	A+B
	Survival Register	A+B	A+B	A+B	A+B	A+B
	Survival Register (2)	<i>use B units</i>	<i>use B units</i>	<i>use A units</i>	<i>use B units</i>	<i>use B units</i>
	OBT	A+B	A+B	A+B	A+B	A+B
	CRT (master OBT)	A	A	B	A	A
	TM Encoder	B	B	A	B	1
	TM/OBT for SM	A	A	B	A>B>A	A
	TC decoder	A	A	B	A>B>A	A
	Nominal PM	PM	A	A	B	A
Cold supply		A	A	B	A	A
SCDB ctrl		A	A	B	A	A
I/O IF (SBAH)		A	A	B	A	A
Boot mode		N	N	N	N	N
SW image	1	2	2	1	1	
I/O	SIO1	all	all	all	all	all
	SIO2	all	all	all	all	all
	SIO3	all	all	all	all	all
SSMM	SSMM ctrl	A+B	A+B	A+B	A+B	A+B
	SSMM banks	0	1	2	0-1-2	0-1-2
PM for SM	PM etc for SM	B	B	A	B	B
	Boot mode for SM	N	N	N	N	N
	SW Image for SM	1	2	2	1	1
CDMS 1553	SCDB	A	A	B	A	A
	SCDB used in SM	B	B	A	B	B
PCDU	1553 IF	A	A	B	A	A
	1553 for SM	B	B	A	B	B
	FCL and LCL	all	all	all	all	all
	BCR	1-2-3	1-2-3	1-2-3	1-2-3	1-2-3
	BDR	1-2	1-2	1-2	1-2	1-2
	HPS	A	A	B	A	A
	HES	(all groups)	(all groups)	(all groups)	(all groups)	(all groups)
	SA-shunts	all	all	all	all	all
	MEA	all	all	all	all	all
BAT	Cell columns	all	all	all	all	all
SA	SA Sections	all	all	all	all	all

# Herschel S/C IST specification

REFERENCE: H-P-2-ASP-SP-0939

DATE: December 20<sup>th</sup> 2007

ISSUE: 6.0

Page : 217

	chapter	5.8.5	5.8.7	5.8.8	5.8.9	5.8.10
	title	Launch Mode robustness	CDMS management	DTCP Worst Case scenario	RMS	Launch Clean Run
Rx	XPND-Rx	A+B	A+B	A+B	A+B	A+B
Tx chain	XPND-SDB-IF	A	A	B	A	A
	XPND-Tx					
	EPC					
	TWT					
Tx chain for SM	XPND-SDB-IF for SM	B	B	A	B	B
	XPND-Tx for SM					
	EPC for SM					
	TWT for SM					
RFND	RFND	1 and 3	1 and 3	2 and 4	1 and 3	1 and 3
	RFND pos in SM	BBBB	BBBB	AABB	BBBB	BBBB
Antennas	MGA	LGA1	MGA	MGA	MGA	LGA1
	LGA1					
	LGA2					
ARAD	ARAD	A+B	A+B	A+B	A+B	A+B
	ARAD used AAD	N	N	N	N	N
	ARAD used CRS	2	2	2	2	2
TRR	Hot supply	A+B	A+B	A+B	A+B	A+B
	RM	A+B	A+B	A+B	A+B	A+B
	PAP/CCS set (2)	PMA nominal	PMA nominal	PMB nominal	PMA nominal	PMA nominal
	CPDU	A+B	A+B	A+B	A+B	A+B
	SGM	A+B	A+B	A+B	A+B	A+B
	Survival Register	A+B	A+B	A+B	A+B	A+B
	Survival Register (2)	use B units	use B units	use A units	use B units	use B units
	OBT	A+B	A+B	A+B	A+B	A+B
PM	PM	A	A	B	A	A
	Cold supply					
	SCDB ctrl					
	I/O IF (SBAH)					
	Boot mode					
I/O	SW image	1	2	2	1	1
	RIOH1 RIOH2	all	all	all	all	all
PM for SM	RCS I/F modules	A	A	B	A	A
	PM etc	B	B	A	B	B
	Boot mode	S	S	S	S	S
	SW Image	1	2	2	1	1
RCS branch for N operation	LV	A	A	B	A	A
	THR FCV/CBH					
RCS branch for SM	LV	B	B	A	B	B
	THR FCV/CBH for SM					
RCS support	Survival CBH for SM	N	N	R	N	N
	Pressure sensor	1 and 2	1 and 2	1 and 2	1 and 2	1 and 2
ACMS 1553	ACMS 1553	A	A	B	A	A
GYRO	IF E	1	1	1	1	1
	axe	A-B-C	A-B-C	A-B-C	A-B-C	A-B-C
STR	STR	A	A	B	A	N/A
RW	RW	N/A	1-2-3-4	1-2-3	1-2-3-4	N/A
CRS	CRS for SM	1	1	2	1	1
CCU	CCU	A and B	A and B	A and B	A and B	A and B
VMC SREM	VMC	with	N/A	N/A	N/A	with
	SREM	with	with	with	with	N/A
SPIRE	SPIRE	N/A	B	B	A	N/A
HIFI	HIFI	N/A	B	B	A	N/A
PACS	PACS	N/A	B	B	A	N/A

# Herschel S/C IST specification

REFERENCE: H-P-2-ASP-SP-0939

DATE: December 20<sup>th</sup> 2007

ISSUE: 6.0

Page : 218

---

Moved to 5.8.11 Moved to 5.8.12



## 6. SUCCESS CRITERIA

### 6.1. DETAILED APPLICABLE CRITERIA

Considering that the present specification is a top level document which call after many sequences, the detailed success criteria are listed for each step of the sequence and sub sequence as part of the test definition (chapter 5).

### 6.2. NO GO CONDITIONS

As a generic statement, as introduced at §5.7, and considering test execution:

- A NO GO condition shall be associated with any parameter being "out of limit". The applicable limits are the values defined by the HPSBD unless otherwise stated in the present specification or associated document. The "out of limit" general wording includes indeed both all the SCOS/CCS automated checking, that is : TM value monitoring against alarm thresholds, dynamic status value checking (consistency check in SCOS 2000 wording), TC pre-validation and post check tests (CEV in SCOS 2000 wording). The "out of limit" covers also the verification of some parameters by the operator as it is requested by some test scripts to allow test to continue.
- A NO GO condition shall be associated with any anomaly event report TM(5,2) or TM (5,4) or TC rejection report TM(1,2) TM(1,8), unless deliberately wanted by the test procedure (test of failure cases).

Except for additional criteria detailed at each step level, the main test success criteria is the absence of NO GO condition.

### 6.3. "OUT OF LIMIT" AND TC CHECKING

#### 6.3.1. BASIC PRINCIPLE

The test success relies except for few test step specificity, on the automated checking realised by the CCS based on HPSDB settings, and specifically the TC checks associated with each TC command.

The baseline is that the TC checking is realised by the CCS in real time whenever possible.

This includes 5 automated processes:

TC precondition checking by CCS (SCOS PTV)

(a TC may be associated at data base level to a set of TM status or value to be in given state / value interval to allow the TC up-link),

TC correct reception by TC decoder (part of SCOS/CCS DCVS)

(the TM/TC transfer protocol provides a feed back from CDMU TC decoder hardware when a TC is properly received),

## TC acknowledge by TC verification service 1 TM (SCOS CVS of "CVS\_source" type "R")

(a TC may be associated with a request for a telecommand verification service 1 TM packet from the unit or function addressed by the TC, to acknowledge the TC acceptance and/or execution steps achievement and/or execution end of the TC. This TM feed back (TM reception reporting success) may be defined at data base level as a systematic and automated verification. Note 1: the service 1 flags are not all supported by all unit and function. "Execution step" flag is specifically supported only by some TC which execution takes a very long, for which a "still alive" signal may be useful. Some TC supports no flags (ex. MAP 0 CPDU\_TC). Note 2: as a rule, only one kind of acknowledge shall be requested, as asking for several can overwhelm the S/C bus bandwidth. Note 3: a service 1 flag may be activated in a TC header to have a feed back for information only (i.e. without a automated CVS monitoring to rise an alarm). Note 4: data base defines the time delay that the unit/function may need to generate the TM (worst case value), SCOS adds automatically constants to take into account system/processing delays and RF link delays (in flight), an alarm is generated when the TM is overdue or negative (TX(1,2) or TM(1,8)).

## TC acknowledge by TM parameter monitoring (SCOS CVS of "CVS\_source" type "V" or "CVE")

(a TC may be associated with one or several TM parameters (direct or derived) status or value to be in a given state / value interval to confirm the TC acceptance and/or execution step achievement and/or execution end. The checking at the end of the time window defined for the transition, may be extended by defining at data base level, a "consistency check" on the TM parameter, that is a permanent monitoring of the parameter with an alarm if its status / value change / go out of value interval defined by the last TC CVE affecting it (see also OOL below). Note 1: data base defines the time delay that the unit/function may need to generate a stable TM (worst case value), SCOS adds automatically constants to take into account system/processing delays and RF link delays (in flight), an alarm is generated if the TM does not match the defined condition at the end of the window. Note 2: SCOS allow several complex options to define expected TM value else than a fixed predefined value, specifically the case of an echo of the TC parameter value.),

## TM parameter monitoring ("OOL")

(a TM parameter may be associated at data base level, with a permanent verification of its value with respect to several limits. The different limits allow to define different level of alarm severity. SCOS defines 5 type of severity "soft OOL", "hard OOL", "delta OOL", "consistency" and "event". The "consistency" case is very specific, because the limits dynamically changes as a function of the CVE history. §6.3.2 recalls the "soft OOL", "hard OOL", "delta OOL", "consistency" and "event" reserved usage for Herschel and Planck projects. Note 1: the monitoring takes automatically into account the validity criteria associated by the data base to the TM parameter to prevent undue alarms. The validity criteria (SCOS) may be a derived parameter (i.e. a function of several direct TM parameters). Note 2: the out of limit alarm is associated at data base level with a repetition filter, so that the alarm is generated only if the fault condition exist for 1 (no filter) to 16 consecutive parameter checks. This setting prevents alarm on transient or spurious. Note 3: a parameter may be associated to up to 16 out of limit criteria, meaning that several "SOFT" or "DELTA" limits may be defined for gradual alarms (see §6.3.2).

The process is straightforward when simulating operation in "visibility". For the others: as:

- launch sequence,
- operation from MTL,

The real time control relies on the real time spying of S/C generated TM from the umbilical connection (for MTL operation the hypothesis is that the CSS will run a copy of the MTL in parallel to S/C to keep its model of the status up to date).

Nevertheless, as introduced at §5.6, each test success shall be determined from TM acquired in a flight representative way. This means that most tests shall end by a simulation of a TM downlink session (DTCP) or specific phase to recover the available stored telemetry in SSMM.

When this telemetry has been already analysed from the umbilical line for test success (that is usually in a non flight representative way), the test success shall be verified by at least comparing the SSMM stored telemetry with the real time acquired one, for being identical. This comparison may be done bit level, packet per packet, which is expected quicker than a "replay" of the test.

For a remaining set of test sequences and test steps, a real time control will not be possible:

- the clean run (by test principle),
- a few case of saturation or filtering of the real-time TM sent onto the umbilical.

For those later cases, the test success will rely on a test session "replay" on the CCS from the retrieved SSMM data (note: test timeline at §5.1.2 does not include the time necessary fore those full or partial replays).

## 6.3.2. *OUT OF LIMIT CONDITION HIERARCHY*

CCS monitoring considers 5 classes of monitoring limits: "soft OOL", "hard OOL", "delta OOL" and "consistency" and "event".

- a "event" limit triggering shall be associated with an automated emergency stop procedure run by the CCS.
- a "HARD OOL" and "consistency" limit triggering shall be associated with a test sequence abort (operator led procedure).
- a "SOFT" or "DELTA OOL" limits triggering, shall call upon the responsibility of the supporting engineering team for deciding in real time either the test abort or its continuation. A SOFT limit is a test failure indicator in any case, but not critical with respect to immediate safety of units under test. Real time decision shall considers if there is a danger for the S/C health (abort), and if not (shall be the case with a soft limit), the decision shall consider with respect to the test objective:
- if there is no more way to consider the test successful, then test is worth to abort to save time or,
- if the alarm open (likely) only minor anomaly on test results, then test is worth to continue (NB. from available real time data, as only post analysis will determine if sequence is acceptable or shall be re-run).

## 7. ORGANISATION AND RESPONSIBILITIES

### 7.1. ORGANISATION

#### 7.1.1. GENERAL ORGANISATION

ASED will realise the test with a support of the instrument team for a real time critical quick look on the instrument data, and success criteria determination when they concern evolved TM analysis not covered by automated Hk TM checks realised by the CCS (IEGSE level data analysis).

The test organisation shall be as follow:

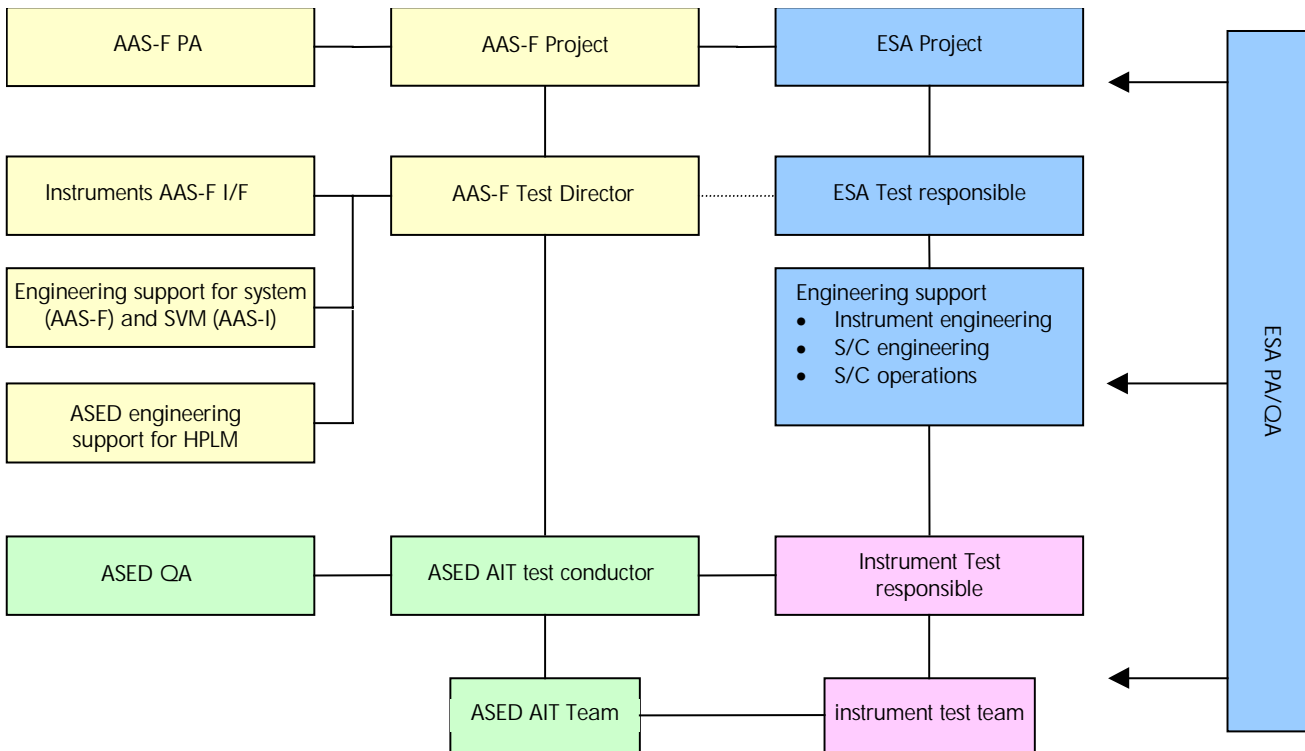

See §7.2 for each actor responsibility definition.

## *7.1.2. INSTRUMENT TEAM SUPPORT*

### *7.1.2.1. Instrument team support to S/C monitoring*

The CCS provides very few statistics upon the science TM(21,x) packets. It is so difficult to detect (in real time) any trouble with the science packet management (or more exactly to discriminate a problem occurring at their level when other packets are also involved).

The instrument team, thanks to IEGSE, shall be able to report in real time upon :

- 1- any discontinuity in the TM packet counter, including nominal ones.
- 2- any TM packet CRC error.
- 3- any TM packet header formatting error.

The above information shall be discriminated between TM(21,X) and the others (House keeping, diagnostic or events, under parallel monitoring by CCS). Note: no packet format error (type 2 or 3) should be detected as the TM/TC DFE shall filter out such packets (leading then to a counter discontinuity of type 1). Such error shall be nevertheless reported as an indicator of a problem at the EGSE system level.

### *7.1.2.2. Instrument team involvement in GO-NOGO*

The instrument team, thanks to IEGSE, shall report at each test step, if the quick look monitoring remains GO, or a NO-GO condition has been detected.

By default, if the CCS monitoring detects no out of limit condition, no anomaly event report TM(5,2) or TM(5,4) and no TC rejection report TM(1,2) TM(1,8) (unless deliberately wanted by the test procedure for failure case test), the test lead will consider the condition "GO" for the next test step.

### *7.1.2.3. Instrument team involvement in (first level) test success confirmation*

Within 2 hours from test sequence end, the instrument team shall be able in a first approach, whether the test is successful at instrument level or not. This statement shall be limited to the fact that:

- 1- the instrument first level behaviour (mode, main status) has been as expected,
- 2- the instrument first level performance (as applicable) has been roughly in expected range,
- 3- all the TM data has been properly collected for post analysis.

This statement will not preclude later finding in the frame of the data detailed post analysis. But it shall report about the confidence that results are successful and that next test can be run in confidence of no generic flaw.

## 7.1.2.4. Post analysis

The detailed post analysis of the instrument TM is an instrument team task. The criteria are under the instrument team responsibility, but, as minimum, the following points shall be confirmed:

- 1- the TM data set as obtained from SSMM dump is complete (no lost packet, no packet format error),
- 2- there is no incoherence between the TM packet data monitored in real time (when available), and the SSMM dumped telemetry,
- 3- all the collected data are correct with respect to their format (i.e. packet structure, limits, calibration),
- 4- instrument behaviour (mode and all status) are as expected (including no spurious),
- 5- instrument performance (as applicable) are in expected range (or explained).

The instrument power supply parameter plots (voltage and current on all lines) will be made available to the instrument team for inclusion in the above analysis point 5.

Note: above list is not a requirement for a report format, and any other relevant synthesis point may be considered by the instrument team.

## *7.1.3. TEST OBSERVATION BY ESA TEAM*

One CCS LAN station is reserved for ESA observer for real time test monitoring.

## **7.2. RESPONSIBILITIES**

ASED is responsible for the test. The overall responsibility during the test is as in following table.

The responsibilities linked to the test progress shall be mentioned in the ASED test leading procedure.

Organisation	Responsibility
AAS-F Project Representative	Alcatel project interface Represents AAS-F during the test and he is also the I/F point with the ESA representative
AAS-F PA	AAS-F Project Assurance Manager
AAS-F Test Director	Issue the test specification of the relevant test to be performed Go ahead for the test reviews (TRR, key point, PTR) Single point of contact with the AAS-F Evaluation team concerning the test result status.
ESA project representative	ESA project interface Represents ESA during the test and he is also the I/F point with the AAS-F representative.
ESA Instruments I/F	I/F with AAS-F test director & instrument evaluation teams

Organisation	Responsibility
ASED AIT Conductor	Responsible of the ASED AIT Team Issue the leading procedure of all activities Manage all activities done during the test including "key point" meeting. I/F point with the Test Facility Team Responsible I/F point with the Instrument AIT Team Responsible Organise the Daily meeting Initialise NCR...
ASED AIT Team	Realise all S/C AIT activities within the arrival and the leaving Issue of the relevant test procedures Operate the GSE (except I-EGSE) Provide the test data Issue the test report.
Instruments AAS-F I/F	Issue section of the test specification relevant to the instrument. AAS-F instrument expert
ASED QA	Organise the review (TRR/PTR...) Minute the running meeting (Key point)
Instrument AIT Team Responsible	I/F point with the ASED test conductor Provide relevant test data in order to help the test director concerning the "Key point" status.
Instrument AIT Team	IEGSE full use Issue the relevant test procedures Process the instrument test data and Test data analysis Issue the test report.
Evaluation teams	Evaluate the test results (depending of test: electrical integration, IST, TV, EMC, ...)

## 7.3. TASK DISTRIBUTION

The preliminary task distribution is the following:

- global specification (present document)                      AAS-F,
- test organisation and preparation                                      ASED,

---

<input type="checkbox"/> test procedure writing and debugging	ASED (to be derived from AAS-I and INST ones),
<input type="checkbox"/> test session direction	ASED,
<input type="checkbox"/> test data analysis	ASED,
<input type="checkbox"/> test report	ASED,
<input type="checkbox"/> test evaluation for HPLM	ASED,
<input type="checkbox"/> test evaluation for instruments	INST teams,
<input type="checkbox"/> test evaluation satellite	AAS-F.

## AAS-F is in charge of Herschel FM AIV

- the satellite activities and test management:
- Responsible of the test management and for interfaces between the satellite, instruments and facility.

## ASED is in charge of Herschel FM AIT

- Preparation (tests definition, except for instruments) and execution
- S/C Cleaning, handling, mechanical mounting, electrical checkout, instruments modes set-up.
- Test management (reviews, leading procedure, daily meeting, key points , ...)
- Dedicated GSE installation/validations and use
- S/C data analysis.
- Running the test (Satellite & Instruments Operator)

## AAS-I is in charge of SVM FM & Herschel AVM AIT

- Provide SVM IST and SIT procedures as a base for S/C IST test procedure definition (inputs).
- On the spot engineering evaluation during tests.

## Instrument teams are in charge of:

- Preparation, tests definition for the instruments
- Dedicated GSE installation/validations and use (I.EGSE)
- Responsible for interfaces between the instrument GSE and test facility.
- Execution and interpretation of instrument performance data
- Provide relevant test data in order to help the test director concerning the "Key point" status.
- Instrument test report



## 8. DOCUMENTATION

### 8.1. DOCUMENTS REQUIRED BEFORE THE TEST

The satellite documentation shall be available and up to date, specifically with respect to:

- S/C configuration (CIDL, etc.)
- Test set-up configuration (CIDL, Definition drawings)
- all units and sub-systems ICD,
- all units and sub-systems User Manuals,
- Test Set-up validation and calibration status,
- Test specification,
- Instrumentation plan (auxiliary thermal sensors list and location as relevant),
- Test leading procedure + elementary procedures,
- all relevant lower level test procedures

Further details shall match TRR requirement.

### 8.2. DATA ACQUIRED DURING THE TEST

All the TM and TC generated for the test shall be recorded for post processing availability.

For the support of test post analysis (first level), a reduced set of data will be selected for real time display and plotting (raw data formatted in spread sheet compatible ASCII format). Those displayed and plotted TM are sequence and sub-sequence specific, but shall allow as a basic requirement, to check the values and timings of the parameters associated with the success criteria as defined for each step, as part of chapter 5.

To this above requirement, shall be added as a generic requirement, the plotting of the satellite power consumption profile with its sharing at least between:

- Each instrument and coolers,
- TCS (heaters distributed power),
- The auxiliary payloads (SREM and VMC),
- The TTC (TWTA and TRSP),
- The RCS (Thruster and CBH supply lines).

The cryostat data (CRYOSCOE and CCU) shall also be plotted systematically.

In a similar manner, as a generic requirement, the plotting of the CDMS, ACMS and Instrument mode transition timing shall be available.

Further details are provided by AD41.

## 8.3. DOCUMENTS ISSUED AFTER THE TEST

### 8.3.1. TEST REPORTS

#### 8.3.1.1. Specimen AIT reports

As a minimum, the specimen AIT reports shall include:

- Test progress description,
- Contamination control report,
- Logbook reporting all significant events about specimen,
- Pictures taken on the specimen in test configuration,
- Record (CD-ROM) of all acquired data during test,
- Test measurements devices calibration reports.

Further details are provided by AD41.

#### 8.3.1.2. Test environment

As a minimum, the specimen AIT reports shall include:

- Test progress description,
- Pictures taken on the test set-up,
- Logbook reporting all significant events about test set-up,
- Record (CD-ROM) of all acquired data during test (as relevant),
- Test measurements devices calibration reports

Further details are provided by AD41.

#### 8.3.1.3. Instrument assessment report

Post-test reviews will be held after each test. Instruments shall provide a quick assessment of the test results, including statement on the successful recording of the relevant data on the I-EGSE, and possibly a preliminary assessment of the test results, to allow the Board to declare if the test can be considered preliminary completed.

## 8.3.2. EVALUATION REPORTS

### 8.3.2.1. Evaluation report for S/C

As a minimum, the S/C evaluation reports shall include:

- Logbook reporting all significant events about each sequence success criteria,
- a short S/C test report including:
  - measured values for success criteria associated with analogue values (ex. DoD, pointing errors, at key steps etc.),
  - test results processing for all phases (plots and specific data processing possibly required step per step).

Further details are provided by AD41.

### 8.3.2.2. Evaluation report for the instrument

As part of the Test Review Boards for each test, Instruments shall provide for each Instrument dedicated IST/SPT a comprehensive assessment of the test results to allow the Board to declare upon the outcome of the test.

As a minimum, the instrument evaluation reports (provided by the instrument support team) shall include:

- Logbook reporting all significant events about each sequence success criteria, and specifically the ones only available from monitoring at IEGSE level,
- a short S/C test report including:
  - measured values for success criteria associated with analogue values (ex. DoD, pointing errors, at key steps etc.),
  - test results processing for all phases (plots and specific data processing possibly required step per step).

specifically for the ones only available from processing at IEGSE level.

Further details are provided by AD41.

**END OF MAIN DOCUMENT**

**APPENDIXES FOLLOW**

## 9. APPENDIX 1 : IST 1 VERIFIED REQUIREMENTS

The IST test shall specifically verify the following requirements (IST applicable requirements according to system level VCD, thanks to DOORS tracking).

## 10.THE DETAILS ARE PROVIDED BY RD107.APPENDIX 2: SATELLITE STATE SUMMARY TABLES

### 10.1. GENERAL TABLE ORGANISATION

The specification uses the following state summary tables.

#### *Satellite state*

CDMS mode		note:		ACMS mode	
TM/OBT		Rx1 / Rx2 rate		PM & SW & B	
PM & SW		TM rate		CRS / FDIR	
SCBP / MTL		Tx chain		GYROs	
FDIR / SrvCBH		Rx 1 Ant.		STRs	
launch straps		Rx 2 Ant.		RWs	
PCDU IF / HPS		CCU		LV	
Battery		SPIRE		THR	
Power domain		HIFI		SREM	
Mass Memory		PACS		VMC	

#### *GSE support*

Power source		TM / TC source		ENV simulator	
--------------	--	----------------	--	---------------	--

The table specification considers the global S/C effective state and that implies typically the verification of several independent observable coherency.

The used "summarised" state values and their acronyms are explicated hereafter.

## 10.2. CDMS MODE

The "CDMS mode" field specifies the CDMS ASW operating mode that shall be active.

The possible values are the following:

<i>Acronym</i>	<i>Full signification</i>		
LAUNCH	Launch Mode		
SAM	Sun Acquisition Mode		
EAM	Earth Acquisition Mode		
NOM	Nominal Mode		
SM	Survival Mode		

(see also appendix 8 §12)

## 10.3. TM / OBT

The "TM / OBT" field specifies which of the two TRR board shall be selected provide the satellite with TM encoding and master On Board Time also called "CRT" (Central Reference Time).

This state is determined from the "TM Encoder and ObtClk ACTIVE" relay position. This single relays is available for command only from ground (direct TC to CPDU on MAP-0) or from the RM (PAP).

The possible values are:

Acronym	Full signification		Note
A	TTR A is master	both TRR enable	nominal
B	TRR B is master	both TRR enable	degraded case
		TRR A or B disabled	degraded case not tested at S/C IST level

Note; the other TRR functions –RM and CPDU– are dynamically arbitrated by the CSEL device in an alternative retry delay system, then are independent of the TM / OBT setting. In S/C IST condition, RM / CPDU A will always be the master unless :

- the RM A is disabled (each RM as a specific RM enable relays that can be commanded from ground only (direct TC to CPDU on MAP-0)),
- TRR A RM has detected an alarm and run a reconfiguration sequence (next alarm trigger will be affected with a 10ms longer reaction delay which sets RM B master).
- The "PM B" configuration shall be run. In this case, the 2 RM operation priority shall be reverted, by inverting the RM-A and RM-B "toggle delay" setting, while reprogramming the RM PAP (mandatory operation for running in PM-B "nominal").

## 10.4. PM & SW

The "PM & SW" field specifies which of the two PM board shall be active, which "PM" shall be used in case of switch over (level 3b or 4 alarm) and the setting that affects the software boot of each of those PM i.e. image and mode.

The active PM (given first) is determined from the "ACTIVE PM" relay position and coherent PM ON / OFF relay position (Note : coherence is enforced by the RM (level 3 alarm) if the setting is not coherent).

The target PM for switch over (given in square brackets) is determined by the RM PAP programming.

For each ones, the two "PM relays" "bit 1" and "bit 0" determine :

- the software image to be used for boot : image 1 or 2,
- if the software shall try to analyse the situation while booting (Nominal boot), or go to SM directly (Survival boot).

This second relay is positioned by the CDMS when it enters SM to force any further incident to ends with a reboot in SM. Note: this is indeed only useful to manage a "SOHO case" not tested as part of S/C IST.

The used

<i>Acronym</i>	<i>Full signification</i>		<i>Note</i>
A1x	PM A active Image 1 SW		nominal case
A2x	PM A active Image 2 SW	failed EPROM or transient case while patching image 1	alarm or degraded case A and B bus roles are inverted in some sequences (§5.9.1) to test all the items of the bus related hardware
B1x	PM B active Image 1 SW	nominal after 3b or 4 alarm	
B2x	PM B active Image 2 SW	nominal after "3c" alarm	
xxN	PM shall analyse context while booting		nominal case
xxS	PM shall (re)boot in SM only	nominal after 1 first entry in SM	
[xy]	switch over target PM setting (to be used in case of 3, 3b or 4 alarm)		[B1N] is nominal case case of 1 permanent PM failure is not tested at IST level



## 10.5. SCBP / MTL

The "SCBP / MTL" first field specifies the Space Craft Bus configuration : active physical bus, and "Profile" (CDMS 1553 bus profile) shall be active.

The possible values are:

<i>Acronym</i>	<i>Full signification</i>		<i>Note</i>
A-x	A (nominal) bus is used		nominal case
B-x	B (redundant) bus is used	after bus A failure	A and B bus roles are inverted in some sequences (§5.9.1) to test all the items of the bus related hardware
x-0	Profile 0		nominal for LAUNCH
x-1	Profile 1		nominal for EAM
x-2	Profile 2		nominal for NOM HIFI prime
x-3	Profile 3		nominal for NOM SPIRE prime
x-4	Profile 4		nominal for NOM PACS prime
x-5	Profile 5		nominal for SAM
x-6	Profile 6		nominal for SM
x-7	Profile 7		nominal for NOM PACS burst
x-8	Profile 8		nominal for NOM Parallel
other	Customised profile		degraded case not tested at IST level

The "MTL / MTL" second field specifies in which state the "MTL software service ()" shall be.

The possible values are:

<i>Acronym</i>	<i>Full signification</i>		<i>Note</i>
OFF	MTL software service is "stopped" but its buffers in SSMM are not yet initialised so service is not yet available		Transient at S/C turn ON.
stopped	MTL software service (105) is "stopped"		Nominal in all mode except in NOM for routine operation
disabled	MTL software service (105) is "running" but MTL TC realise is disabled for all subschedules		Used for trouble shooting
running	MTL software service is "running" and MTL TC realise is enabled at least for some enabled APID and subschedule		Nominal for operation at L2

## 10.6. FDIR / SRVCBH

The "FDIR / SrvCBH " first field specifies in which setting the CDMS FDIR software service shall be.

Note: the CDMS FDIR software service is always AFS when CDMS mode is not NOM.

The possible values are:

Acronym	Full signification		Note
AFS	Autonomous Fail Safe		nominal outside NOM mode
AFO	Autonomous Fail Operational		nominal in for observations (in NOM mode)

The " FDIR / SrvCBH" second field specifies in which state the thruster survival heaters shall be.

The possible values are:

Acronym	Full signification		Note
OFF			Transient at S/C ON
N only	LCL 17 is ON, LCL 18 is OFF		Nominal
R only	LCL 18 is ON, LCL 17 is OFF	N SrvCBH failed	Degraded case N and R SrvCBH roles are inverted in some sequences (§5.9.1) to test the hardware

Note 1: the survival heaters are the FDIR settings are independent.

Note 2: the survival heaters are under CDMS control and are independent from the ACMS (which controls a complementary set of heaters (see ACMS / RCS field)).

Note 3: each survival heater lines (N&R) ensures the heating of both A and B thruster branch at the same time, then SrvCBH setting is independent from RCS setting (used thrusters) or any other ACMS settings.

## 10.7. LAUNCH STRAPS

The "launch straps" field specifies in which position the 8 separation straps shall be (LPS SCOE). [...]The possible values are:

<i>Acronym</i>	<i>Full signification</i>		<i>Note</i>
not separated	the 8 separation straps are in not separated state		nominal case for launch until separation
all separated	the 8 separation straps are n separated state		nominal case for orbital life
7 separated	strap no7 separated while the others are not	strap 7 failure during launch	failure cases tested as part of "LAUNCH mode robustness" sequence
3 not separated	strap no3 not separated while the others are	strap 3 failure at separation	
other			degraded case not tested at S/C IST level

The state referred by the specification is both the state of the simulated strap presence (relays in LPS SCOE) and their reading by the S/C in CDMS and ACMS Hk TM. Both data shall be verified as been consistent (NB. this is nominally done automatically by the database checks associated with the LPS SCOE commands).

## 10.8. PCDU IF / CBH

The "PCDU IF / CBH" first field specifies which PCDU 1553 I/F shall be in use for its control.

The PCDU I/F are controlled by individual relays. Then both ON or both OFF configuration are possible, and the PCDU I/F inherit its I/F configuration from previous setting when the satellite is powered ON.

The possible values are:

<i>Acronym</i>	<i>Full signification</i>		<i>Note</i>
IF A	IF A is active IF B is OFF		nominal case
IF B	IF B is active IF A is OFF		degraded case A and B roles are inverted in some sequences (§5.9.1) to test the hardware cross straps
both OFF	both IF are OFF		transient state when switching over between the two IF as a stationary configuration, this is a not a possible situation (multiple failure)
both ON	both IF are ON		degraded case not tested at S/C IST level (double failure)

The "PCDU IF / CBH" second field specifies which PCDU 1553 I/F is in use for its control.

## 10.9. BAT

The "BAT" field specifies which shall be the battery state as reported by the PCDU battery management electronics.

The field informs about the battery state of charge and the battery management state.

The possible values are (first term):

<i>Acronym</i>	<i>Full signification</i>		<i>Note</i>
> x% SOC	Battery state of charge shall be higher than x %.		usual verification of battery margin
100% SOC	Battery is fully charge and left isolated (no need for its power)	accurate simulation not necessary	nominal case for most of the flight configurations
CHARGED (BS)			
< x% SOC	Battery state of charge shall be lower than x%.		associated to specific verification of the DoD (level 4) alarms.

The possible values are (second term):

<i>Acronym</i>	<i>Full signification</i>		<i>Note</i>
CHG	Battery is charged from SA		The 3 BCR are ON
DSG	Battery is providing power to the bus		The 2 DBR are ON
TPR	Battery charge from SA is ending (taper charge)		Only 1 BCR is ON
	Battery is left isolated (only monitoring is running)		nominal case for most of the flight configurations

<i>Acronym</i>	<i>Full signification</i>		<i>Note</i>
(BS)	The flight battery is not connected and the test is conducted with the battery simulator instead.		

## 10.10.POWER DOMAIN

The "Power domain" field specifies in which "domain" the bus regulation shall be operating, which is also an indication upon the origin of the S/C power supply.

The possible values are:

<i>Acronym</i>	<i>Full signification</i>		<i>Note</i>
SA	Solar array supplies the S/C		nominal configuration for most flight configuration
BAT	Battery supplies the S/C		nominal for the launch only and possible worst case survival mode transition tests
SA < 6 sections	Umbilical supplies the S/C		nominal only for the S/C preparation under the fairing
SA + BAT	Solar array supplies the S/C		possible to handle very high power transient configuration but not a nominal stable situation

The domain shall be determined from the reading of the MEA voltage telemetry. Threshold between domains are given in the PCDU UM and ICD.

## 10.11.SSMM

The "SSMM" field specifies which shall be the configuration of the Mass Memory.

The possible values are:

<i>Acronym</i>	<i>Full signification</i>		<i>Note</i>
3 banks (1,2,3)	SSMM A and SSMM B are both configured with bank x, y, x in 0,1,2 positions	one of the bank 1 2 or 3 has failed	nominal configuration
3 banks (x,y,z) x,y,z ≠ 1,2,3			the bank allocation is rotated in some sequences (§5.9.1) to test all the possible degraded cases
(≥) 1 bank (noX)	SSMM A and SSMM B are both configured with bank X in 0 position		nominal simplified configuration (shorter S/C turn ON)
3/1 banks	SSMM A is configured with 3 bank, while SSMM B is configured with 1 bank		specific to RMS sequence. The SSMM-B size is reduced to test the packet store saturation

## 10.12.NOTE

The "Note" field is used for important reminder in specific cases.

## 10.13.RX1 / RX2 RATE

The "Rx1 / Rx 2 rate" field specifies configuration in which the TC up-link shall be configured.

The possible values are:

<i>Acronym</i>	<i>Full signification</i>		<i>Note</i>
125bps	XPND 1 and 2 are configured for 125bps up-link.		nominal configuration for SM condition
4kbps	XPND 1 and 2 are configured for 4kbps up-link.		nominal configuration for LAUNCH condition
4k / 125	XPND 1 is configured for 4kbps up-link and XPND 2 for 125bps up-link.		nominal configuration for L2 and LEOP operations
125 / 4k	XPND 1 is configured for 125bps up-link and XPND 2 for 4kbps up-link.	XPND 1 Rx failure	XPND roles are inverted in some sequences (§5.9.1) to test the hardware. This configuration is also used in some of the separation tests

Beside the specification concentrate on the operational "rate" issue, the configuration check shall include all the Rx parameter checking, specifically reception level (AGC) and frequency shift.

## 10.14.TME / TX RATE

The "TME / Tx rate" field specifies configuration in which the TM down-link shall be configured, considering both the active TM encoder, and the active XPND Tx setting (if ON).

Beside the specification concentrate on the operational "rate" issue, the configuration check shall include all the CDMS and active Tx parameter checking, specifically the sub-carrier modulation type (in TM encoder) and the RF modulation index (in XPND), etc.

A specific suffix is added when one of the transponder is configured for ranging.

The possible values are:

<i>Acronym</i>	<i>Full signification</i>		<i>Note</i>
500bps	TM encoder and active XPND (if ON) are configured for 500bps down-link.		nominal configuration for SM or SAM condition (except SAM after separation)
5kbps	TM encoder and active XPND (if ON) are configured for 5000bps down-link.		nominal configuration for SAM after separation
150kbps	TM encoder and active XPND (if ON) are configured for 150kbps down-link.		nominal configuration for LEOP and L2 operation in EAM or NOM
1.5Mbps	TM encoder and active XPND (if ON) are configured for 1.5Mbps down-link.		nominal configuration for DTCP science data down-load

Recall : the active TM encoder (A or B) is linked to the TM/OBT setting.

The possible other values are (suffix):

<i>Acronym</i>	<i>Full signification</i>		<i>Note</i>
+RNG	Ranging is active		
	Ranging is deactivated		

## 10.15.TX CHAIN

The "Tx chain" field specifies which units shall be in use for the transmission function.

Beside the specification concentrate on the operational "rate" issue, the configuration check shall include all the TTC parameter checking, specifically the TWTA TM, etc.

The possible value are (first part):

<i>Acronym</i>	<i>Full signification</i>		<i>Note</i>
OFF	the two XPND Tx and TWTA are all OFF.		S/C turn ON transient
T.1(RF OFF) A.OFF(LCL ON)	XPND 1 Tx ON, but RF output disabled, EPC A OFF but supplied (LCL ON).		nominal for launch
T.1 RF OFF	XPND 1 Tx ON, but its RF output is disabled and the TWTA A is OFF (EPC and LCL)		nominal configuration out of communication sessions (this configuration allow to get XPND 1 telemetry from its 1553 I/F.
T.1 A.A xxx	XPND 1 + TWTA A are in use transmitting on antenna xxx		nominal configuration for communication sessions
T.2 RF OFF	XPND 2 Tx ON, but its RF output is disabled and the TWTA B is OFF (EPC and LCL)	XPND 1 or TWTA A failed	Tx cahins roles are inverted in some sequences (§5.9.1) to test the hardware.
T.2 A.B xxx	XPND 2 + TWTA B are in use transmitting on antenna xxx	XPND 1 or TWTA A failed	nominal configuration in SM or DTCP with inverted roles
other			transient state or degraded cases not tested at IST level.

Note 1: the transmission chain turn ON requires 5 commands. The XPND Tx shall be supplied (LCL), its RF output shall be enabled (HLC), the EPC shall be supplied (LCL), turned ON (HLC) and its supply of the TWTamp shall be enabled (HLC). The TWTamp (high voltage) supply enable command acts on the EPC sequencer which keeps this command in memory and delay its action up to if the TWTamp 180s warm-up sequence is not yet completed. Then the Tx chain may be in warm up while commanded for being fully ON du to the protective hardware delay in the EPC.

Note 2: in nominal configuration, when XPND 1 and TWTA A are used, the XPND 2 and TWTA B remain OFF (LCL and units). When after a failure (or for an "all B" test, the XPND 2 and TWTA B are used, the XPND 1 and TWTA A remain OFF (LCL and units).



The antenna used for the transmission (RFDN configuration) is added (when chain is active). Possible value are:

<i>Acronym</i>	<i>Full signification</i>		<i>Note</i>
LGA 1	LGA 1 is used for transmission		
LGA 2	LGA 1 is used for transmission		
MGA	MGA is used for transmission		

## 10.16.RX 1 ANT AND RX 2 ANT

The " RX 1 Ant" and "Rx 2 Ant" field specify which antenna the transponder 1 and 2 shall be respectively working with.

The possible value are:

<i>Acronym</i>	<i>Full signification</i>		<i>Note</i>
LGA 1	XPND 1 / 2 is associated with LGA1 for Rx at least		
LGA 2	XPND 1 / 2 is associated with LGA 2 for Rx at least		
MGA	XPND 1 / 2 is associated with MGA for Rx at least		

Note 1: the RX and Tx antenna associated with one XPND can be different. This is however a degraded case not tested in the frame of IST.

Note 2: the RFDN symmetry implies that each antenna / XPND configuration can be realised by 4 different combinations of the switches. Only the nominal RFSW configuration will be tested in the frame of the IST, and fully altered one.

To simplify the nominal / redundant unit testing, the "units B" B test will be realised with a special configuration which correspond to a double failure : (TX / RX 1 or TWTA A) AND (RFSW 1 or 3).

The corresponding 4 tested configuration are detailed in the next table.

The RF switches position for the ALL B case have been chosen because it comes directly from the base 1B,2B,3B,4B configuration, and switch between the MGA / LGA1 configuration using RFSW 2 and 4 instead of 1 and 3. The proposed configuration allows all the redundant functions of the TTC chain to be tested at once.

Beware that the RFSW configuration is not the default FDIR configurations which are designed to handle a single failure either at XPND + TWTA or et the RFSW level, not both at the same time.

# Herschel S/C IST specification

REFERENCE: H-P-2-ASP-SP-0939

DATE: December 20<sup>th</sup> 2007

ISSUE: 6.0

Page : 244

<i>Field</i>	<i>setting</i>	<i>RF SW</i>	<i>Note</i>
Tx chain	T.1 A.A LGA 1	1B,2B,3B,4B	Nominal for LGA 1 use
Rx 1 Ant	LGA 1		
Rx 2 Ant	LGA 2		
Tx chain	T.1 A.A MGA	1A,2B,3A,4B	Nominal for MGA use
Rx 1 Ant	MGA		
Rx 2 Ant	LGA 1		
Tx chain	T.2 A.B LGA 1	1B,2A,3B,4B	all "unit B" configuration used for LGA 1 use.
Rx 1 Ant	LGA 2		
Rx 2 Ant	LGA 1		
Tx chain	T.2 A.B MGA	1B,2B,3B,4A	all "unit B" configuration used for MGA use.
Rx 1 Ant	LGA 1		
Rx 2 Ant	MGA		
others			degraded case not tested in the frame of the IST (either SPF FDIR related or not)

## 10.17.CCU

The "CCU" field specify in which state are the CCU.

The possible value are:

<i>Acronym</i>	<i>Full signification</i>		<i>Note</i>
OFF	The 2 CCU are OFF.		This is nominally a transient state only. The OBSW CCU management service may be ON and provide HK TM filled with irrelevant data.
A,B ON Hk	The 2 CCU are ON, and the OBSW CCU management service provides cryostat HK TM packets. at default sampling rate (512s)		Nominal
A,B ON 8s-Hk	The 2 CCU are ON, and the OBSW CCU management service provides cryostat HK TM packets. at 8s sampling rate.		Nominal for launch
A,[B]* ON Hk [A]*,B ON Hk	The 2 CCU are ON, and the OBSW CCU management service provides cryostat HK TM packets. at default sampling rate (512s) but the CCU marked by the square brackets are not linked to its sensors		Configuration allowing to keep a set of sensor connected to the CRYOSCOE, for the test sequences that endure many reconfiguration, then for which S/C provided cryostat TM is limited
A ON Hk	Only 1 of the CCU is ON.	CCU B failed	some of "unit B" configuration tested as per §5.9.1
B ON Hk	The OBSW CCU management service provides the cryostat HK TM from this single unit.	CCU A failed	
other			transient states or degraded cases not tested.

## 10.18.SPIRE

The "SPIRE" field specify which mode the instrument mode that shall be active.

The possible values are:

<i>Acronym</i>	<i>Full signification</i>		<i>Note</i>
OFF	The instrument is fully OFF		
INIT	SPIRE is in "INIT" mode. This is a transient state between the OFF and ON state.		This state is the base for DPU soft patching (instrument commissioning).
ON	SPIRE is in "ON" mode. Only the PDU is ON. HK is provided.		
STBY	SPIRE is in "READY" mode. The full instrument is powered but is in standby providing only HK TM.		Warning this is not the SPIRE "STD BY" mode which produces reduced science data.
PHTM	SPIRE in "photometry" mode. It provides science data.		
SPECTRO	SPIRE in "spectroscopy" mode. It provides science data.		
Cooler	SPIRE is in "Cooler Recycle". Only HK is provided.		
SAFE	SPIRE is in "SAFE" mode. Only the DPU is ON, and provides HK TM.		Entered when the instrument self detect an error.
CMSNG	SPIRE is in "Commissioning".		DPU SW ignores all errors.
others			INIT and ON

(not used)

## 10.19.PACS MODE

The "PACS" field specifies the instrument operating mode that shall be active.

The possible values are:

<i>Acronym</i>	<i>Full signification</i>		<i>Note</i>
OFF	The instrument is fully OFF		
INIT	PACS is in "INIT" mode. This is an intermediate step between the OFF state and "STBY" mode.		This state is the base for DPU soft patching (instrument commissioning).
STBY	PACS is in "SAFE" mode. The full instrument is powered but is in standby providing only HK TM.		
NON-PRM	PACS is in "NON PRIME". The mode is similar to SAFE except that HK TM rate is reduced by a factor of 2.		
OBS	PACS is in "OBS" mode. This is an intermediate step between the SAFE mode and the instrument operation.		
PRM	PACS is in "PRIME" mode. It provides science data.	PRM-CAL PRM-LNSP PRM-RGSP PRM-DBPH PRM-SBPH	Calibration Line Spectroscopy Range Spectroscopy Dual Band Photometry Single Band Photometry
PRL	PACS in "PARALLEL" mode. It provides science data.	PRL-SBPH PRL-DBPH	Single Band Photometry Dual Band Photometry
Cooler	PACS is in "Cooler Recycle". Only HK is provided.		
RESCUE	PACS is in "RESCUE" mode. This is an intermediate mode between the OFF state and "INIT" mode.		This mode is entered at boot in specific (error) conditions.
DTCCR	PACS is in "DETECTOR CURING" mode.		
others			

## 10.20.HIFI MODE

The "HIFI" field specifies the instrument operating mode that shall be active.

The possible values are:

<i>Acronym</i>	<i>Full signification</i>		<i>Note</i>
OFF	The instrument is fully OFF		
INIT	HIFI is in "INTERMEDIATE" mode. This is an intermediate step between the OFF state and "STBY" mode.		This state is the base for DPU soft patching (instrument commissioning).
STBY	HIFI is in "STAND-BY" mode. The full instrument is powered but is in standby providing only HK TM.		
PRM	HIFI is in " PRIME" mode. It provides science data.		
RESCUE	HIFI is in "RESCUE" mode. This is an intermediate mode between the OFF state and "INIT" mode.		This mode is entered at boot in specific (error) conditions.
others			

## 10.21.ACMS MODE

The "ACMS mode" field specifies the ACMS ASW operating mode that shall be active.

The possible values are the following:

<i>Acronym</i>	<i>Full signification</i>		
SBM	Standby Mode		Nominal for launch
SAM	Sun Acquisition Mode		
SCM	Science Mode	(SUN) (EARTH) (PT ½) (OBS)	Sun and Earth pointing are based on ACMS ephemerides. PT ½ is inertial fix pointing chosen to be about mid course between Earth and Sun at time of test. OBS is any observation mode
OCM	Orbit Control Mode	(SUN) (EARTH) (PT ½) (ΔV)	
SASM	Sun Acquisition Survival Mode		in case of ACMS alarm and ACMS reconfiguration
SBSM	Survival Stand by Mode		Transient only to SASM

The ACMS sub-state in the mode and the target (when applicable ) are usually added.

<i>Acronym</i>	<i>Full signification</i>		
presep	SBM sub-state		
post sep	"post sep" is transient only		
(CS) or (FN)	SAM and OCM stable sub-state "Coarse" or "Fine"		the sub-states is linked to the "Coarse" or "Fine" RCS setting nominal operation requires to move out of SAM or OCM mode to other modes from the "FINE" state.
(Earth) (Sun)	The ACMS shall point a target representative of the Earth or Sun direction , but not necessarily Qcir or Qsir respectively		
(Qcir) (Qsir)	The ACMS shall point Qcir or Qsir respectively		
(OBS)	The ACMS shall point a direction representative of a simulated science observation		

(see also appendix 8 §12).

## 10.22.PM & SW & B

The " PM & SW & B" two first field specify which of the two PM board shall be active, which "PM" shall be used in case of switch over (level 3b or 4 alarm) and the setting that affects the software boot of each of those PM i.e. image and mode.

The active PM (given first) is determined from the "ACTIVE PM" relay position and coherent PM ON / OFF relay position.

The target PM for switch over (given in square brackets) is determined by the RM PAP programming.

For each ones, the two "PM relays" "bit 1" and "bit 0" determine :

- the software image to be used for boot : image 1 or 2,
- if the software shall skip the PM board checks to save time at boot (Survival boot), or shall perform them all (Nominal Boot).

This second relay is normally positioned as Nominal for the active PM, and Survival for the switch over target.

The used values are the following:

<i>Acronym</i>	<i>Full signification</i>		<i>Note</i>
A1x	PM A active Image 1 SW		nominal case
A2x	PM A active Image 2 SW	failed EPROM or transient case while patching image 1	alarm or degraded case A and B roles are inverted in some sequences (§5.9.1) to test all hardware
B1x	PM B active Image 1 SW	nominal after 3b or 4 alarm	
B2x	PM B active Image 2 SW		
xxN	PM shall run full check while booting		nominal case
xxS	PM shall run quickened boot	nominal for entry in SBSM and SASM	
[xy]	switch over target PM setting (to be used in case of 3, 3b or 4 alarm)		[B1S] is nominal case case of 1 permanent PM failure is not tested at IST level

The " PM & SW & B" two first field specify which physical 1553 bus shall be used by the ACMS for communicating with its 1553 sensors.



Possible values are:

<i>Acronym</i>	<i>Full signification</i>		<i>Note</i>
A	bus A (nominal) is in use		nominal case
B	bus B (redundant) is in use	A bus failed	nominal case in SM A and B roles are inverted in some sequences (§5.9.1) to test all hardware

## 10.23.CRS / FDIR

The "CRS / FDIR" first field specifies how the CRS 1 and 2 shall be affected. The 2 CRS may be allocated to 2 functions : SM survival ACMS operation and ARAD (Angular Rate Anomaly Detector).

The possible values are:

<i>Acronym</i>	<i>Full signification</i>		<i>Note</i>
OFF	CRS 1, 2 are OFF		ground operation
1A, 2S	CRS 1 ON, used for ARAD, CRS 2 ON, used for SM.		nominal
2A, 2S	CRS 2 ON, used for both ARAD and SM. CRS 1 OFF.	case CRS 1 failed	degraded case cyclically tested at IST level
1A, 1S	CRS 1 ON, used for both ARAD and SM. CRS 2 OFF.	case CRS 2 failed	
2A 1S			A and B roles are inverted in some sequences (§5.9.1) to test all hardware

The "FDIR" field specifies in which mode the ACMS FDIR shall operate.

The possible values for the FDIR are:

<i>Acronym</i>	<i>Full signification</i>		<i>Note</i>
AFS	Autonomous Fail Safe		nominal for all modes except for observation
AFO	Autonomous Fail Operational		nominal for observations, but also recommended as default
NA	Not Applicable		the AFO AFS concept is not applicable in SBSM or SASM
other	N/A		

WARNING : in SAMS or SBSM, ACMS TM continue to provide an "AFO" / "AFS" status. But this one is irrelevant.

## 10.24.GYROS

The "GYROS" field specifies how the 4 GYROS heads and their redundant electronics shall be affected.

The possible values are:

Acronym	Full signification		Note
OFF	GYRO are OFF		nominal in SBSM, SASM
A,B,C IF 1	IF 1 is turn ON, The data from the gyro heads A B and C are used. head D data is used only for FDIR		nominal in NOM or OCM
B,C,D IF 1	IF 1 is turn ON, The data from the gyro heads A B and C are used.	head A failed	degraded case cyclically tested at IST level as per §5.9.1 (case head D failed that implies only that FDIR check sum is no more available, is considered covered by the other cases)
A,C,D IF 1	IF 1 is turn ON, The data from the gyro heads A B and C are used.	head B failed	
A,B,D IF 1	IF 1 is turn ON, The data from the gyro heads A B and C are used.	head C failed	
A,B,C IF 2	IF 1 is turn ON, The data from the gyro heads A B and C are used.	IF 1 failed	
other			degraded case not tested at IST level (multiple failure)

## 10.25.STR

The "STR" field specifies which of the two STR board shall be active.

Note that the ACMS control the STR ON/OFF at unit level but CDMS control the STR LCLs.

The possible values are:

Acronym	Full signification	note	Note
OFF	both STR are OFF		nominal for launch
LCL A B ON	STR LCL are activated by CDMS but CDMS left them OFF		nominal for SM or SAM
A (LCL B ON)	STR A is active and B LCL is set		nominal for SCM, HCM, OCM
B (LCL A ON)	STR A is active and B LCL is set		degraded case tested at IST level ("units B" configuration)
A & B ON	STR A is active for ACMS but B is also ON		nominal for testing one STR while the other is used for ACMS

# Herschel S/C IST specification

REFERENCE: H-P-2-ASP-SP-0939

DATE: December 20<sup>th</sup> 2007

ISSUE: 6.0

Page : 253

B & A ON	STR B is active for ACMS but A is also ON		
other			degraded case not tested at IST level

## 10.26.RW

The "RW" field specifies how the 4 RW shall be affected.

The possible values are:

<i>Acronym</i>	<i>Full signification</i>		<i>Note</i>
OFF	The 4 RW are OFF		nominal in SBM, SAM & SM
1,2,3,4 ON	The 4 RW are used in hot redundancy.		nominal in NOM or OCM
2,3,4 ON	only 3 RW are used, the 4 <sup>th</sup> is OFF	RW 1 failed	degraded case cyclically tested at IST level as per §5.9.1
1,3,4 ON		RW 2 failed	
1,2,4 ON		RW 3 failed	
1,2,3 ON		RW 4 failed	
1,2,3,4 ON	When running with "PM B", the nominal ACC IO-N IF is marked failed to force the use of the redundant IO IF.	IO-N failed	
other			degraded case not tested at IST level (multiple failure)

## 10.27.LV

The "LV" field specifies if the use of the propulsion system branch is active for use by the ACMS.

For safety, the CDMS control the LCL that supply the ACC command electronics for the LV (tank latch valves) and the RCS (thruster flow control valves) (this provides 2 safety barriers).

The possible values are:

Acronym	Full signification	note	Note
OFF	both RCS branch Latch Valves are closed and no thruster can be fired		nominal for launch
A ON B OFF	RCS branch A Latch Valve is open and branch A thrusters can be fired		nominal for all operation except SASM
A OFF B ON	RCS branch B Latch Valve is open and branch B thrusters can be fired	something failed in branch A	nominal for SASM A and B roles are inverted in some sequences (§5.9.1) to test all hardware
A ON B ON	RCS branch B Latch Valve are open		periodic pressure balance with unused branch. not tested in S/C IST

## 10.28.THR

The "THR" field specifies if the state of the propulsion system.

The first field specify the used branch.

Possible values are:

<i>Acronym</i>	<i>Full signification</i>		<i>Note</i>
A	THR A (nominal) are in use		nominal case
B	THR B (redundant) are in use	something failed in RCS A	nominal case in SM A and B roles are inverted in some sequences (§5.9.1) to test all hardware

The second filed specify the thruster CBH (Catalytic Bed Heaters supply state).

The possible values are:

Acronym	Full signification	note	Note
CBH OFF	all the Thruster CBH are OFF		
CBH-T ON	only the "C" thruster CBH (pure torque) are ON		nominal in all other mode than OCM (or launch)
CBH-A ON	all the thruster CBH are ON		nominal in OCM or for preparing an OCM

## 10.29.VMC, SREM

The "VMC and SREM " field specifies the state of the auxiliary payloads.

The possible values are for VMC:

Acronym	Full signification	note	Note
OFF	the unit is OFF		nominal for most S/C life except for the post separation sequence
ON	the unit is ON taking image		nominal after launch
ON	the unit is ON with image in memory available for down load		nominal after launch
other			degraded case not tested at IST level

The possible values are for SREM:

Acronym	Full signification	note	Note
OFF	the unit is OFF		nominal for launch and LEOP
ON	the unit is ON and integrating		nominal after launch
ON SW OFF	the unit is ON but the associated CDMS-BSW service is OFF		nominal transient after CDMS level 3 alarm or CDMS PM reset cases
other			not tested at IST level

## 10.30.POWER SOURCE

The "Power source" field specifies the SCOE setting for supplying the S/C.

The possible values are:

Acronym	Full signification	note	Note
UMB	the LPS provides power to S/C		nominal before launch
SAS-6	the SAS provides power to S/C while simulating the LPS		only 6 sections are used
SAS	the SAS provides power to S/C		nominal after launch
BS	the BATSIM provide power		nominal for testing launch mode in sequence where the FM battery is not connected.
none	the S/C is OFF or supplied from FM battery		nominal for launch sequence and clean run.

Note: the fact that SAS is providing power to the S/C does not preclude that BS (or FM battery) can be also required to provide some power to handle S/C peak of power consumption (this may be necessary to handle some RW peak demand).

## 10.31.TM TC SOURCE

The "TM TC source" field specifies the SCOE setting for receiving TM and sending TC to the S/C as well as the VC to be used (i.e. addressed on board TC decoder).

The possible values are:

Acronym	Full signification	note	Note
UMB x bps	TC and TM are sent / get through the umbilical link at a x bps setting for the uplink (recall : umbilical uplink setting is independent or Rx 1 and Rx2 one)		nominal before launch
UMB / none	TM are get through the umbilical link, but the uplink signal is fully deactivated (no signal no clock)		nominal for spying TM activity when the TWTA is OFF
LGA1	TC and TM are sent / get through the LGA1 antenna test cap using the RF SCOE		nominal in Launch, SAM and SM mode.
MGA	TC and TM are sent / get through the LGA1 antenna test cap using the RF SCOE		nominal in NOM and EAM.
UMB / LGA1 UMB / MGA	TC sent / get through the LGA1 or MGA antenna test cap using the RF SCOE, while TM are received		used in some sequence step to simulate the transmission in "blind" to the satellite (TWTA

	by the umbilical		OFF), while actually spying it from the umbilical the configuration is also used to switch OFF the S/C after the launch clean run
--	------------------	--	--

The VC0 and VC1 for TC shall be used alternatively when no specific need require it else (i.e. some TRR board functions are accessible only when addressing the VC of its TC decoder). In real operation VC0 if used when day is odd. VC1 if test day is even (a way to test that both are reliable). VC usage is imposed for each S/C IST sequence (see TC decoder setting in §5.9.1 tables). To the above data, a last indication specify which VC shall be used for the uplink (DFE setting).

The possible values are:

Acronym	Full signification	note	Note
VC0	TC frame header specifies that the TC shall be processed by TC decoder A		nominal
VC1	TC frame header specifies that the TC shall be processed by TC decoder B		nominal

## 10.32.ENV SIMULATOR

The "ENV simulator" field specifies the ACMS SCOE setting.

The possible values are:

Acronym	Full signification	note	Note
stand by	the ACMS SCOE is ON and configured but not allowed to provide ACMS sensor stimulation		ACMS 1553 bus monitoring is active. Actuator activity monitoring is active
initialised	the ACMS SCOE only wait for a trigger command to begin close loop simulation starting from given initial condition.		
close loop	the ACMS SCOE stimulates the ACMS sensor according to the S/C attitude it computes, considering the actuator action history		Nominal case for test.



## 11. APPENDIX 3: OPERATION GENERAL PROCEDURE SPECIFICATION

DELETED

As the S/C IST have been defined up-stream of operation procedure, the flight operation procedures are not applicable. As they derive for most both from the same users manuals and sub-system test procedures, they shall be strongly related.

This is nevertheless not part of S/C IST to ensure any reconciliation.

## 12. APPENDIX 4 : SSMM INITIALIZATION

The following paragraph gives the general instructions to set the SSMM in operation for the IST purpose. More details and explanations can be found in CDMS documentation, specifically the BSW user manual [P-HPL-NOT-00029-SE] and the BSW ICD [P-HPL-NOT-00076-SE].

### 12.1. SSMM TURN ON AND SSMM BSW SERVICE INITIALISATION

Verify that the SSMM is not already ON from the board status acquired by the TRR boards and reported in the DID\_MM\_ON\_OFF data pool data [EEDG160 or EEDH160 for MM A and EEDJ160 or EEDZ160 for MM B, daughters of EEDF160]. A spurious reset would generate dozens of error messages. Note that those TM are not part of HK TM: a new TM packet shall be created to access them. As an alternative, a good hint at SSMM state may be considered from the individual bank state (see next paragraph for TM codes).

If OFF, turn ON the SSMM board using a CDMS-TC(2,3) of 208ms at least (16 pulse duration units) on the line:

- 53 "MM A On / MM A Reset" and /or [DCM53170],
- 69 "MM B On / MM B Reset" [DCM53170].

The pulse length is automatically managed by the HPSDB instanced commands.

The SSMM board and BSW SSMM management service shall then be initialised by a CDMS-TC(8,4,2,6) command for the related MM A and / or MM B. This initialisation has done automatically and shall not be repeated if the SSMM was already ON when the PM was reset (BSW boot checks the SSMM state and executes a CDMS-TC(8,4,2,6) automatically if it finds it ON).

Wait for the SSMM initialisation completion event by TM(1,7) (the CDMS-TC(8,4,2,6) shall be flag with a "TC execution completed" acknowledge request). This may also be monitored from the CDMS-TC(8,4,2,6) execution in progress status available in P1 HK TM [DEDT7161, daughter of DEDT0161].

### 12.2. SSMM MANAGEMENT INITIALISATION

Verify that the 4 banks are OFF from the board status acquired by the TRR boards and reported in the DID\_MM\_BANK\_POWER\_A and DID\_MM\_BANK\_POWER\_B data pool data [DEECG160, DEECH160, DEECZ160, DEECJ160, daughter of DDECF160 for MM A, and DEECK160, DEECK160, DEECK160, DEECK160, daughter of DDECF160 for MM B]. The command may be rejected else with some configuration. See BSW user manual and ICD for details if necessary (basics is that the bank at position 0 shall be first ON last OFF, including when position are remapped).

For the 2 SSMM boards using CDMS-TC(8,4,2,4):

- set MAP memory bank 0 to position 0,
- set MAP memory bank 1 to position 1,
- set MAP memory bank 2 to position 2,
- se MAP memory bank 3 to position 3.

As part of the degraded case sampling, the above nominal flight configuration will be alternated by filling the 4 positions with the following configurations:

- bank 3,1,2,0 (bank 0 failed),
- bank 0,3,2,1 (bank 1 failed),
- bank 0,1,3,2 (bank 2 failed).

Those alternated configuration makes sense only when needed configuration is 3 banks.

Turn ON the bank allocated to each position using CDMS-TC(8,4,2,5). Bank at position 0 shall be first ON (last OFF). Turn ON then the bank associated with position 1 and 2 as needed for the test. The baseline is that the bank at position 3 is left OFF (cold redundant).

## 12.3. STORE STATUS CHECK

Send CDMS-TC(8,4,3,3) to verify the allocated packet stores via TM(8,6,3,3).

Verify that the SEL and Default packet stores have been allocated in SSMM and the CEL has been allocated in SGM.

Send CDMS-TC(15,5) to verify the packet store selection definition via TM(15,6).

Verify that all is routed to the TM in the Default packet store. If any standard packet store has been allocated, verify that the Default packet store does not contain the selection definition of the standard packet store.

Verify that the configurations of SSMM A and SSMM B are the same (nominal way of using the SSMM is full hot redundancy (duplication of all stores). Note that RDO6 is obsolete in this respect (it considers 3-1 and not 3-3 configuration).

## 12.4. PACKET STORE CREATION

### 12.4.1. MTL, OBCP AND AUXILIARY BUFFERS ALLOCATION

The lowest 0.1 Gibit of SSMM are allocated for buffers and auxiliary functions (RDO6 allocation). This allocation is rounded to 12.75Mo to ease the address management (should be 12.8Mo).

Note that the lowest 163800 addresses (160ko) at position 0 (0x1.0000.0000 to 0x1.0002.7FFFF) are specifically reserved for the BSW and the SSMM HW controller.

The lowest start address for packet stores shall be 0x1.00CC.0000 (12.75Mo)

## 12.4.2. 1 BANK CASE

The following parameters shall be used:

CDMS_TC(8,4,3,1) parameters								
Packet Store Name	for	Packet Store Type	Virtual Channel	Packet Store Id	Start address <hex>		Length <dec>	Comment
		TYP	VC	ID	SAD		LEN	
Default	MMA MMB	Cyclic (0)	Dump on VC2 (0)	StorID_000(0x00) StorID_128(0x80)	0x1 0x3	.0140.8000	4 227 072	
SEL	MMA MMB	Cyclic (0)	Dump on VC2 (0)	StorID_001(0x01) StorID_129(0x81)	0x1 0x3	.0181.0000	4 501 504	20h00 at 0.2kbps
HK	MMA MMB	Cyclic (0)	Dump on VC2 (0)	StorID_001(0x02) StorID_129(0x82)	0x1 0x3	.01C5.B000	174 690 304	20h00 + 25mn* at 5kbps
Science	MMA MMB	Cyclic (0)	Dump on VC3 (1)	StorID_001(0x03) StorID_129(0x83)	0x1 0x3	.0C2F.4000	869 253 120	15h50 at 122kbps

Note : parameters for CDMS\_TC(8,4,3,1) Allocate Packet Store

## 12.4.3. 3 BANK CASE

The following parameters shall be used:

CDMS_TC(8,4,3,1) parameters								
Packet Store Name	for	Packet Store Type	Virtual Channel	Packet Store Id	Start address <hex>		Length <dec>	Comment
		TYP	VC	ID	SAD		LEN	
Default	MMA MMB	Cyclic (0)	Dump on VC2 (0)	StorID_000(0x00) StorID_128(0x80)	0x1 0x3	.0140.9000	4 549 380	
SEL	MMA MMB	Cyclic (0)	Dump on VC2 (0)	StorID_001(0x01) StorID_129(0x81)	0x1 0x3	.0185.FB04	11 324 296	50h11 at 0.2kbps
HK	MMA MMB	Cyclic (0)	Dump on VC2 (0)	StorID_001(0x02) StorID_129(0x82)	0x1 0x3	.0232.C68C	429 110 908	50h11 at 5kbps
Science	MMA MMB	Cyclic (0)	Dump on VC3 (1)	StorID_001(0x03) StorID_129(0x83)	0x1 0x3	.1BC6.7D08	2 755 166 968	50h11 at 122kbps

Note : parameters for CDMS\_TC(8,4,3,1) Allocate Packet Store

## 12.4.4. IMPLEMENTATION NOTE

This allocation is a scale down of the ESOC 3 Bank configuration, taken into account:

- that minimum size of a packet is 4 227 072 bytes (4Mo + 32ko),
- the Mass Memory area between FC.0000 and 140.73C0, despite part of reserved area for ASW buffer, is indeed unused (2.6.2, 2.8 version at least). The buffer use deliberately this space to check this fact. In case of interference, it shall be detected by the BSW when initialising the packet store, or the OBCP service which MM buffer top is located just a few under the 140.8000 address.

The above constrained scale down of the 1 bank configuration corresponds to a theoretical ~16h00 autonomy for on board full TM recording and 5h of HK only data (covering configuration phases). However, the recording configuration is a few different (see next chapter) and the debug and test are more demanding in reports and events than "normal" operation. Then, it is worth considering that the autonomy is more likely around 12h only, and procedure shall ensure that an SSMM store download (MM A and MM B) is done at less than 12h intervals when using 1 bank configuration.

AAS-F recommend in fact to insert an SSMM download between each test sequence to ease SSMM data retrieval during post analyses (i.e. one SSMM download set per test).

## 12.5. DEFINE PACKET STORE SELECTION CRITERIA

Define selection criteria for the defined packet stores using CDMS-TC(15,3) commands.

The baseline shall be:

Packet Store Name	CDMS_TC(15,3) parameters						Comment
	Store ID	N1	APID	Type	N2	Sub-Type	
	<dec>	<dec>	<dec>	<dec>	<dec>	<dec>	
Default	0 128						
SEL	1 129	24	16, 512	1	0	0	
			1024, 1025	5	0	0	
			1152, 1153 1280, 1281	8	1	6	
HK	2 130	1	16	8	3	7,8,9	
		4		11 12 15 19	0	0	
		3	16, 1152, 1153	18	0	0	
		10	16, 512	3 6	0	0	NB. N1 = 40 leads to a too long TC packet, the configuration shall be loaded with 2 TC
		30	1024, 1025 1152, 1153 1280, 1281	9 14 17			
		8	18, 518 1026, 1027 1154, 1155 1282, 1283	3	0	0	

Science	3 131	12	1028, 1029, 1030, 1031 1156, 1157, 1158, 1159 1284, 1285, 1286, 1287	21	1	0	
---------	----------	----	---	----	---	---	--

**Implementation notes:**

Note 1

This definition is a few different from the ESOC's one in the sense that ALL the TM packets which are theoretically possible are allocated to one store. So the default store shall remain empty during all the tests.

Note 2

During the transient between the default store(s) initialisation and end of the store configuration, the CDMS will route not yet allocated APID/Type/subtype combination to the default store(s). Then, nominally, those stores will not appear empty if checked once the above initialisation is finished (the assumption is here that all packets are allowed for storage per service 14, as default shall be).

Then, as a end of Packet store initialisation, the two default store shall be emptied the following way:

checked for no more recording any entry by asking two CDMS\_TC(15,12) on those stores at one minute interval (pointers shall not move)

downloaded with a CDMS\_TC(15,7) (the content shall be post analysed as coherent wrt above process)

checked for having been read correctly with a CDMS\_TC(15,12) ("read" pointer shall have join the "write" pointer value)

emptied with a CDMS\_TC(15,9) (taking the current date and time as "end time" value)

checked again as empty with a CDMS\_TC(15,12) ("start" pointer shall have join the "write" and "read" pointer values)

After allocation, the correctness of packet store TM selections shall be verified by sending a CDMS-TC(15,5) to get a TM(15,6): it shall be checked that both that the definition of all stores are the defined ones, and that the definition of the Default store has been modified accordingly.

As a result of the transient non allocation of some TM to a store, the default store will become to be filled with TM as soon as created, the filling disappearing as the TM are allocated to a dedicated store. As part of the end of the SSMM initialisation sequence, the content of the default store for both SSMM a and B shall be downloaded to allow a post analysis of the above described transient. Then the two default store content shall be deleted, so that they appear empty for all the subsequent operations with the S/C.

## 13. APPENDIX 5 : ACMS SETTINGS FOR TEST

The following paragraphs specifies the ACMS settings to be applied for the purpose of the IST test.

Those settings are optimised with respect to the RMS sequence, but the settings for the other sequences shall use the same basis. Specifically, the start condition are applicable to all the sequences.

### 13.1. REFERENCES

[R1] Memo DG issue 1, "Herschel pointing commanding sequence during spacecraft IST", January 25<sup>th</sup> 2006

[R2] *ESA mail – Ian Rasmussen – « Pointing modes for Herschel IST » dated 03/01/2006.*

[R3] *DS technical note TC definition H-P-4-DS-TN-024*

### 13.2. INTRODUCTION

This memo defines the sequence of pointing command to be sent to the spacecraft during the mission reference scenario test case (section 7.8.9).

In absence of specific information, the commanding applies independently of instruments. The sequence is defined for 12 hours ending with same target as the first one. The sequence can then be commanded again for next instrument.

### 13.3. SOFTWARE VERSION

It has to be noted that ACMS OBS V2 doesn't contain all pointing mode capability. SRPE non compliance (covered by DS RFD 10) mitigation has been implemented in OBS V3.

The V2 ACMS telecommands are defined in H-P-DS-TN-024 issue 3.7 whereas V3 ACMS Telecommands are defined in issue 3.8 of the same document.

The sequence of pointing has been built independently of the software version : it is proposed same sequence is used. The detail content of the telecommand will change depending of the SW version. The memo is flagging the differences when relevant.

### 13.4. STARTING CONDITIONS

The following setting shall be used:

- ▶ Simulation Starting date (separation) : launch date + 2 months. Selected Launch date = 28<sup>th</sup> of February 2008 14:34:55.

- ACMS SCOE has been configured so that initial Sun vector in inertial frame is (1,0,0) and spacecraft initial attitude is  $(0, 1/\sqrt{2}, 0, 1/\sqrt{2})$ .
- ACMS is in SAM/fine with ACMS units (STR, RWS) needed for SCM put in configuration.
- Wheels are biased so as to achieve the next 24 hours pointing needs.
- Start ACMS FDIR mode is AFS.

## 13.5. SEQUENCE OF COMMANDING

### 13.5.1. COMMAND A FINE POINTING

A fine pointing shall be commanded by applying FCP-H-D-FINEP. Note : the manoeuvre is 5 min long, target = [accurate] sun pointing.

**TC\_PERFORM\_SCM\_FINE\_POINTING ACMS-TC(8,4,101,200)** shall be to be sent with following parameters :

- interlacing = **01** (no interlacing)
- q\_fine = q1 =  $(0, 1/\sqrt{2}, 0, 1/\sqrt{2})$  (quaternion associated with sun direction)
- t\_slew = **180 s** (see note below)
- t\_p = **300 s**

Time tag of the TC shall be Start\_date + 01:00:00 hours (1 hrs contingency to bias the wheel with TC .

*Note* : tslew could be computed using "Herschel slew time prediction" algorithm of ACMS user manual (section 9.4.1). The configuration is 4 wheels and the slew angle is below 5 deg. It gives 161 sec. 180 s is selected.

### 13.5.2. COMMAND AFO MODE

The ACMS AFO FDIR setting shall be commanded.

The **TC\_SET\_FDIR\_MODE ACMS-TC(8,1,200)** shall be to be sent filled with following parameters :

- FDIR mode = **2**.

*Note* : this TC is a critical command.

Time tag of the TC shall be Start\_date + 01:10:00 (2 minutes after end of last TC)



### 13.5.3. COMMAND A FINE POINTING IN SSO AFTER A SLEW OF 2° AROUND Y.

A fine pointing in SSO after a slew of 2° around Y shall be commanded by applying FCP-H-D-SSO and FCP-H-D-FINEP.

**TC\_TRACK\_SOLAR\_SYSTEM\_OBJECT ACMS-TC(8,4,104,151)** shall be sent with following parameters :

SSO coefficients = (reuse the same coefficients as DS-TS-022)

X0 = **0.0**

Y0 = **0.0**

Z0 = **0.0**

X1 = **0.0**

Y1 = 0.00000245

Z1 = **0.0**

X2 = **0.0**

Y2 = **0.0**

Z2 = **0.0**

X3 = **0.0**

Y3 = **0.0**

Z3 = **0.0**

Time tag of the TC shall be **Start\_date + 01:11:00.**

**TC\_PERFORM\_SCM\_FINE\_POINTING ACMS-TC(8,4,101,200)** shall be sent with following parameters :

interlacing = **01** (no interlacing)

q\_fine = **(0, 0.719339800338651, 0, 0.694658370458997)**

t\_slew = **130 s** (see note below)

t\_p = **7200 s** (2 hours see [R2])

Time tag of the TC shall **Start\_date + 01:12:00.**

Note : Slew time prediction [ACMS user manual (section 9.4.1)] gives 123.3 s.

## 13.5.4. COMMAND A LINE SCANNING WITH OFF POSITION,

A line scanning with OFF position shall be commanded by applying FCP FCP-H-D-SCAN.

**TC\_PERFORM\_SCM\_LINE\_SCAN ACMS-TC(8,4,101,230)** shall be sent with following parameters :

- interlacing = **01** (no interlacing)
- q\_scan = q\_scan1 = **(0, 0.719339800338651, 0, 0.694658370458997)** [target of start first line identical to previous fine pointing]
- N = **10** (number of lines)
- Phi = **0** deg
- D1 = **0.0174532925199433 rad** (1 deg - angular extension of the lines)
- d2 = **0.00174532925199433 rad** (0.1 deg - angular distance between successive lines)
- r = **0.000290888208665722 rad/s** (60 arcsec/s - Scan rate)
- tslew = **170 s** (by similarity with DS-TS-10, see also note below)
- tll = **100 s** (line-to-line manoeuvre duration - by similarity with DS-TS-10).
- qoff = **(0, 1/√2, 0, 1/√2)** (Inertial target attitude quaternion of the OFF-position = sun pointing) (WARNING to 2°).
- K = **9** (Number of consecutive lines before going to the OFF-position)
- Tsop = **200 s** (by similarity with DS-TS-10)
- Top = **300 s** (off position duration)

Time tag of the TC shall be **Start\_date + 03:13:00**.

Note 1: Slew time prediction to off position [ACMS user manual (section 9.4.1)] gives 139.6 s (angle is 3.13 deg).

Note 2: Tslew and tll are filled by similarity with DS-TS-010 since the slew path prediction tool is not available.

## 13.5.5. COMMAND FOUR NODDING ARRANGED AS 2X2 RASTER

Four nodding arranged as 2x2 raster shall be commanded by applying FCP FCP-H-D- RASTP.

Note : items flagged in **yellow** are applicable **only** if version higher than V3 are used.

**TC\_PERFORM\_SCM\_RASTER\_POINTING ACMS-TC(8,4,101,210)** shall be sent with following parameters:

- interlacing = **01** (no interlacing)
- **CP = ON** (calibration point is used)

- $q_{\text{rast}} = Q_{\text{rast}} 1 = (0.00560179833648578, 0.713228450830475, 0.00550487189379061, 0.700887646607351)$  [target of 1<sup>st</sup> raster point = end of last scan]
- $N = 10$  (number of lines)
- $M = 2$  (number of steps per line)
- $\Phi = 45 \text{ deg}$  (Tilt angle defining the rotation of the scan pattern axes)
- $d1 = 0.00116355283466289 \text{ rad}$  (4 arcmin - angular distance between successive steps)
- $d2 = 0 \text{ rad}$  (The condition  $d2 = 0$ , means that it shall be possible to scan  $N$  times the points of a single line)
- $t_{\text{slew}} = 100 \text{ s}$  (duration to reach first point – margin since first raster point =end of last scan)
- $t_p = 45 \text{ s}$  (Duration of stable pointing).
- $t_{pp} = 61 \text{ s}$  (Allowed duration of the point-to-point manoeuvre- see note below)
- $t_{ll} = 61 \text{ s}$  (Allowed duration of the line-to-line manoeuvre)
- $q_{\text{off}} = Q_{\text{rast}} 1$  (Inertial target attitude quaternion of the OFF-position)
- $K = 2$  (Number of consecutive raster steps before going to the OFF-position)
- $t_{\text{sop}} = 61 \text{ s}$  (maximum slew time from a point in the raster to the OFF position.)
- $t_{\text{op}} = 15 \text{ s}$  (off position duration)
- **Top-init = 15 s** (duration of initial off position for calibration)

Time tag of the TC shall be **Start\_date + 04:13:00**.

Note : Slew time prediction of the point-to-point manoeuvre [ACMS user manual (section 9.4.1)] gives 60.9 s (angle is 4 arcmin deg).

**TC\_PERFORM\_SCM\_RASTER\_POINTING ACMS-TC(8,4,101,210)** shall be sent with the same parameter values as previous one except :

- $q_{\text{rast}} = Q_{\text{rast}} 2 = (0.005602199, 0.713177479, 0.005504465, 0.700939512)$
- $t_{\text{slew}} = 25 \text{ s}$

Time tag of the TC shall **Start\_date + 05:13:00**

Note : Slew time prediction [ACMS user manual (section 9.4.1)] gives 23.2 s (angle is 0.5 Arcmin).

**TC\_PERFORM\_SCM\_RASTER\_POINTING ACMS-TC(8,4,101,210)** shall be sent with the same parameter values as previous one except :

- $q_{\text{rast}} = Q_{\text{rast}} 3 = (0.005654062, 0.71317707, 0.005555438, 0.70093911)$

Time tag of the TC shall be **Start\_date + 06:13:00**

**TC\_PERFORM\_SCM\_RASTER\_POINTING ACMS-TC(8,4,101,210)** shall be sent with the same parameter values as previous one except :

- **q\_rast = Q\_rast 4 = (0.005629768, 0.716228695, 0.005580056, 0.697820625)**

Time tag of the TC shall be **Start\_date + 07:13:00**

### 13.5.6. *COMMAND A SLEW NEAR THE BORDER OF THE ADD ZONE*

A slew near the border of the AAD zone shall be commanded.

**TC\_PERFORM\_SCM\_FINE\_POINTING ACMS-TC(8,4,101,200)** shall be sent with following parameters :

- interlacing = **01** (no interlacing)
- **q\_fine = (0, 0.863835505204396,0, 0.503773977045526)**
- **t\_slew = 400** (see note below)
- **t\_p = 3600 s** (1 hours )

Time tag of the TC shall **Start\_date + 08:13:00**.

Note : Slew time prediction [ACMS user manual (section 9.4.1)] gives 398.4 s for a slew angle of 30°.

### 13.5.7. *COMMAND INTERLACING WHILE STAYING AT THE SAME DIRECTION*

A command interlacing shall be commanded while staying in the same direction.

**TC\_PERFORM\_SCM\_FINE\_POINTING ACMS-TC(8,4,101,200)** shall be sent with following parameters :

- interlacing = **10** (interlacing acticated)
- **q\_fine = (0, 0.863835505204396,0, 0.503773977045526)**
- **t\_slew = 0 s** (no slew needed)
- **t\_p = 3600 s** (1 hours )

Time tag of the TC shall be **Start\_date + 09:13:00**.

### 13.5.8. *COMMAND A SLEW BACK TO SUN POINTING WITH INTERLACING ACTIVATED*

A slew back to Sun pointing shall be commanded while interlacing is activated.

**TC\_PERFORM\_SCM\_FINE\_POINTING ACMS-TC(8,4,101,200)** shall be sent with following parameters:

- interlacing = **10** (interlacing activated)
- $q_{\text{fine}} = q1 = (0, 1/\sqrt{2}, 0, 1/\sqrt{2})$  (quaternion associated with sun direction)
- $t_{\text{slew}} = \mathbf{300}$  s
- $t_{\text{p}} = \mathbf{3600}$  s

Time tag of the TC shall **Start\_date + 10:13:00**.

**Sequence end**

As the S/C is back pointing to the simulated Sun direction, the overall sequence may be looped.

# Herschel S/C IST specification

REFERENCE: H-P-2-ASP-SP-0939

DATE: December 20<sup>th</sup> 2007

ISSUE: 6.0

Page : 272

## 14. APPENDIX 6 : LCL LIST

Line n°	Herschel Allocation	To	P PDU Connector	Pin (+)	Pin (-)	Type	Class	OP-LCL	HLC cmd	Essential Non-Ess	PCDU Module
1	CDMU Hot A	<b>CDMU</b>	J016	4 5	2 6	FCL	I	N/A	N/A		Dist-8
2	CDMU Hot B	<b>CDMU</b>	J136	4 5	2 6	FCL	I	N/A	N/A		Dist-3
3	XPND1 Rx	<b>XPND1</b>	J04 J05	15 15	8 8	FCL	I	N/A	N/A		Dist-7
4	XPND2 Rx	<b>XPND2</b>	J04 J05	15 15	8 8	FCL	I	N/A	N/A		Dist-4
5	ACC Hot A	<b>ACC</b>	J016	4 5	2 6	FCL	I	N/A	N/A		Dist-6
6	ACC Hot B	<b>ACC</b>	J126	4 5	2 6	FCL	I	N/A	N/A		Dist-5
7	Emergency Heater Line 1 Nom	<b>Bat</b>	J05	1	4	FCL	I	N/A	N/A		Dist-10
8	Emergency Heater Line 1 Red	<b>Bat</b>	J06	1	4	FCL	I	N/A	N/A		Dist-1
9	Emergency Heater Line 2 Nom					FCL	I	N/A	N/A		Dist-9
10	Emergency Heater Line 2 Red					FCL	I	N/A	N/A		Dist-2
11	SPIRE HSDPU Nom	<b>HSDPU</b>	J01	8	4	LCL	I	YES		NE	Dist-3
12	SPIRE HSDPU Red	<b>HSDPU</b>	J02	2	4	LCL	I	YES		NE	Dist-8
13	GYRO A	<b>GYRE</b>	J01A	33	57	LCL	II			E	Dist-2
14	GYRO B	<b>GYRE</b>	J01B	33	57	LCL	II			E	Dist-9
15	QRS1	<b>QRS1</b>	J01	1	3	LCL	I			E	Dist-2
16	XPND2 Tx	<b>XPND2</b>	J04 J05	9 9	1 1	LCL	I			E	Dist-9

# Herschel S/C IST specification

REFERENCE: H-P-2-ASP-SP-0939

DATE: December 20<sup>th</sup> 2007

ISSUE: 6.0

Page : 273

Line n°	Herschel Allocation	To	P PDU Connector	Pin (+)	Pin (-)	Type	Class	OP-LCL	HLC cmd	Essential Non-Ess	PCDU Module
17	Cat Bed Heaters Nom	THR20Ns	Splice			LCL	I			NE	Dist-10
18	Cat Bed Heaters Red	THR20Ns	Splice			LCL	I			NE	Dist-1
19	SREM	<b>SREM</b>	J01	8	7	LCL	I			NE	Dist-3
20	VMC	<b>VMC</b>	J01	4	3	LCL	I			NE	Dist-8
21	STR 1	<b>STRE1</b>	J01	3	1	LCL	I			E	Dist-10
22	STR 2	<b>STRE2</b>	J01	3	1	LCL	I			E	Dist-1
23	XPND1 Tx	<b>XPND1</b>	J04 J05	9 9	1 1	LCL	I			E	Dist-1
24	QRS2	<b>QRS2</b>	J01	1	3	LCL	I			E	Dist-10
25						LCL	I			E	Dist-1
26						LCL	I			E	Dist-10
27	<b>PACS BOLC Nom</b>	<b>FPBOLC</b>	J25	2 7	4 9	LCL	II	<b>YES</b>		NE	Dist-8
28	<b>PACS BOLC Red</b>	<b>FPBOLC</b>	J26	2 7	4 9	LCL	II	<b>YES</b>		NE	Dist-3
29						LCL	II	<b>YES</b>		NE	Dist-3
30						LCL	II	<b>YES</b>		NE	Dist-8
31	CDMU Cold A	<b>CDMU</b>	J015	4 5	2 6	LCL	II		YES	E	Dist-2
32	CDMU Cold B	<b>CDMU</b>	J135	4 5	2 6	LCL	II		YES	E	Dist-9
33	ACC Cold A	<b>ACC</b>	J015	4 5	2 6	LCL	II		YES	E	Dist-6
34	ACC Cold B	<b>ACC</b>	J125	4 5	2 6	LCL	II		YES	E	Dist-5
35	PACS SPU Nom	<b>FPSPU1</b>	J11	2 1	4 5	LCL	II			NE	Dist-5
36	PACS SPU Red	<b>FPSPU2</b>	J11	2 1	4 5	LCL	II			NE	Dist-6

# Herschel S/C IST specification

REFERENCE: H-P-2-ASP-SP-0939

DATE: December 20<sup>th</sup> 2007

ISSUE: 6.0

Page : 274

Line n°	Herschel Allocation	To	P PDU Connector	Pin (+)	Pin (-)	Type	Class	OP-LCL	HLC cmd	Essential Non-Ess	PCDU Module
37	CCU A	<b>CCU</b>	J13	2	9	LCL	II			E	Dist-1
38	CCU B	<b>CCU</b>	J26	2	9	LCL	II			E	Dist-10
39						LCL	II			NE	Dist-4
40						LCL	II			NE	Dist-7
41	PACS DPU Nom	<b>FPDPU</b>	J01	2 7	4 9	LCL	II			NE	Dist-7
42	PACS DPU Red	<b>FPDPU</b>	J02	2 7	4 9	LCL	II			NE	Dist-4
43	HIFI WEH	<b>FHWEH</b>	J03	2	4	LCL	II			NE	Dist-8
44	HIFI WEV	<b>FHWEV</b>	J03	2	4	LCL	II			NE	Dist-3
45	ACC RCS Thrusters A	<b>ACC</b>	J106	1 2	4 8	LCL	III	YES	YES	E	Dist-2
46	ACC RCS Thrusters B	<b>ACC</b>	J116	1 2	4 8	LCL	III	YES	YES	E	Dist-9
47	ACC RCS LV A	<b>ACC</b>	J105	1 2	4 8	LCL	III	YES	YES	E	Dist-1
48	ACC RCS LV B	<b>ACC</b>	J115	1 2	4 8	LCL	III	YES	YES	E	Dist-10
49	TWTA 1	<b>EPC1</b>	J01 J02	2 2	5 4	LCL	III	YES		E	Dist-2
50	TWTA 2	<b>EPC2</b>	J01 J02	2 2	5 4	LCL	III	YES		E	Dist-9
51	<b>SPIRE HSFCU Nom</b>	<b>HSFCU</b>	J05	2	4	LCL	III	YES		NE	Dist-4
52	<b>SPIRE HSFCU Red</b>	<b>HSFCU</b>	J06	2	4	LCL	III	YES		NE	Dist-7
53	<b>HIFI LCU Nom</b>	<b>FHLCU</b>	J01	2	4	LCL	III	YES		NE	Dist-7
54	<b>HIFI LCU Red</b>	<b>FHLCU</b>	J121	2	4	LCL	III	YES		NE	Dist-4
55	Reaction Wheel 1	<b>RWE</b>	J01	1 6	4 9	LCL	III	YES		E	Dist-2
56	Reaction Wheel 2	<b>RWE</b>	J01	1 6	4 9	LCL	III	YES		E	Dist.9



# Herschel S/C IST specification

REFERENCE: H-P-2-ASP-SP-0939

DATE: December 20<sup>th</sup> 2007

ISSUE: 6.0

Page : 275

Line n°	Herschel Allocation	To	P PDU Connector	Pin (+)	Pin (-)	Type	Class	OP-LCL	HLC cmd	Essential Non-Ess	PCDU Module
57	Reaction Wheel 3	<b>RWE</b>	J01	1 6	4 9	LCL	III	YES		E	Dist-1
58	Reaction Wheel 4	<b>RWE</b>	J01	1 6	4 9	LCL	III	YES		E	Dist-10
59						Par-LCL	III	YES		E	Dist-4
60						Par-LCL	III	YES		E	Dist-4
61						Par-LCL	III	YES		E	Dist-7
62						Par-LCL	III	YES		E	Dist-7
63	HIFI HRH	<b>FHHRH</b>	J01	2	4	Par-LCL	III	YES	YES	NE	Dist-5
64	HIFI ICU Nom	<b>FHICU</b>	J01	2	4	Par-LCL	III	YES		NE	Dist-5
65	PACS DEC/MEC1	<b>FPMEC1</b>	J30	2 7	4 9	Par-LCL	III	YES		NE	Dist-5
66						Par-LCL	III	YES		NE	Dist-5
67	HIFI HRV	<b>FHHRV</b>	J01	2	4	Par-LCL	III	YES	YES	NE	Dist-6
68	HIFI ICU Red	<b>FHICU</b>	J02	2	4	Par-LCL	III	YES		NE	Dist-6
69	PACS DEC/MEC2	<b>FPMEC2</b>	J130	2 7	4 9	Par-LCL	III	YES		NE	Dist-6
70						Par-LCL	III	YES		NE	Dist-6
71	PLM NCA Actuators Nom	<b>CBPLM1A</b>	J01	2	4	NCA act	NCA		YES	NE	Dist-3
72	PLM NCA Actuators Red	<b>CBPLM1A</b>	J02	2	4	NCA act	NCA			NE	Dist-8

# Herschel S/C IST specification

REFERENCE: H-P-2-ASP-SP-0939

DATE: December 20<sup>th</sup> 2007

ISSUE: 6.0

Page : 276

## 15. APPENDIX 7: TBC TBD AND TBW LIST

TBC	location	Object	Baseline	associate
2	3.2	HPLM user manual reference		ASED
TBD	location	Object	Baseline	associate
TBW	location	Object	Baseline	associate
11	7.8.3.8	Cryostat commissioning procedure	Flight operation procedures	ASED

## 16. APPENDIX 8: S/C CDMS AND ACMS OPERATING MODES

Here follows some diagrams and tables to recall the basic CDMS and ACMS operation principles.

- CDMS is in charge of S/C data handling (communication, SSMM, MTL, etc.),
- ACMS is in charge of S/C attitude and orbit control (and nothing else).

The two subsystems run in their own computer in full independence. With respect to ACMS, CDMS is just in charge to route ACMS-TC and ACMS-TM from/to ground, either in real time or through MTL (TC) and SSMM (TM).

Each subsystem computer, run on PM-A (nominal) or -after a trouble- on PM-B (cold redundant). Each subsystem is monitored for (a major) anomaly by each two independent RM operating in hot redundancy.

In case of an alarm condition detected by one of the subsystem RM (Reconfiguration Module), a reconfiguration of the faulty computer is attempted (reset of PM-A or switch-over to PM-B), and a flag is set (relay position) to notify the other subsystem of the contingency condition, and allow this one to take adapted conservative predetermined dispositions.

Then autonomous ACMS and CDMS mode transitions are linked either to an internal alarm (with internal RM action), or to the observation by the PM, of an alarm flag coming from other subsystem.

Internal autonomous mode transitions, are associated with CDMS-FDIR or ACMS-FDIR alarm of level 3 or 4.

alarm name	problem	(internal) action (2)	Note
3	anomaly detected in the PM operation (watch dog, supply disruption, CPU or CROME hardware alarm, software alarm)	switch other	for CDMS and LAUNCH only (S/C not separated)
3a		reset PM-A	occur on first alarm case (as seen by RM)
3b		switch other	occur on second alarm case (as seen by RM)
3c (1)		reset PM-B on SW image 2	CDMS only.
4	major anomaly detected through RM own sensors	switch-over	CDMS : DOD alarm (battery nearly empty) ACMS : ARAD alarm (attitude going out of range)

(1) : this is not an official naming, this is just used here for readability.

(2) : the action considers the nominal case : PM-A operating, default alarm setting (not a degraded configuration).

The above alarms, once executed by one RM, cannot be triggered again (until ground performs specific actions to valid them again). However, there is two RM operating, with a built in mechanism that insures that they acts alternatively. Then, a series of 7 PM alarms would give rise theoretically (it is impossible in reality unless two or more severe failures) to the following alarm reconfiguration pattern:

- 3a (RM-A) 3a (RM-B) 3b (RM-A) 3b (RM-B) 3c (RM-A) 3c (RM-B) ignored (RM-A and RM-B).

The notifying flags are the following:

flag name	problem	consequence	requested reaction of the other sub-system
AIR	level 3 or 4 in ACMS	ACMS restore a Sun pointing	CDMS shall adapt its TTC setting to poor antenna pointing.
CIR	level 3 in CDMS	CDMS detailed operation context is lost	ACMS shall go to Earth pointing (if it can) to wait a ground recovery action.

SIR	level 4 in CDMS (power contingency alarm)	ACMS shall go to Earth pointing (using small power) to get Sun power and then, wait for ground action.
-----	---	--

The following figure presents the CDMS operating modes that results in a normal operation context (i.e. not starting from a CDMU degraded configurations or not considering contingency recovery cases whose management requires typically the alarms behaviour reprogramming).

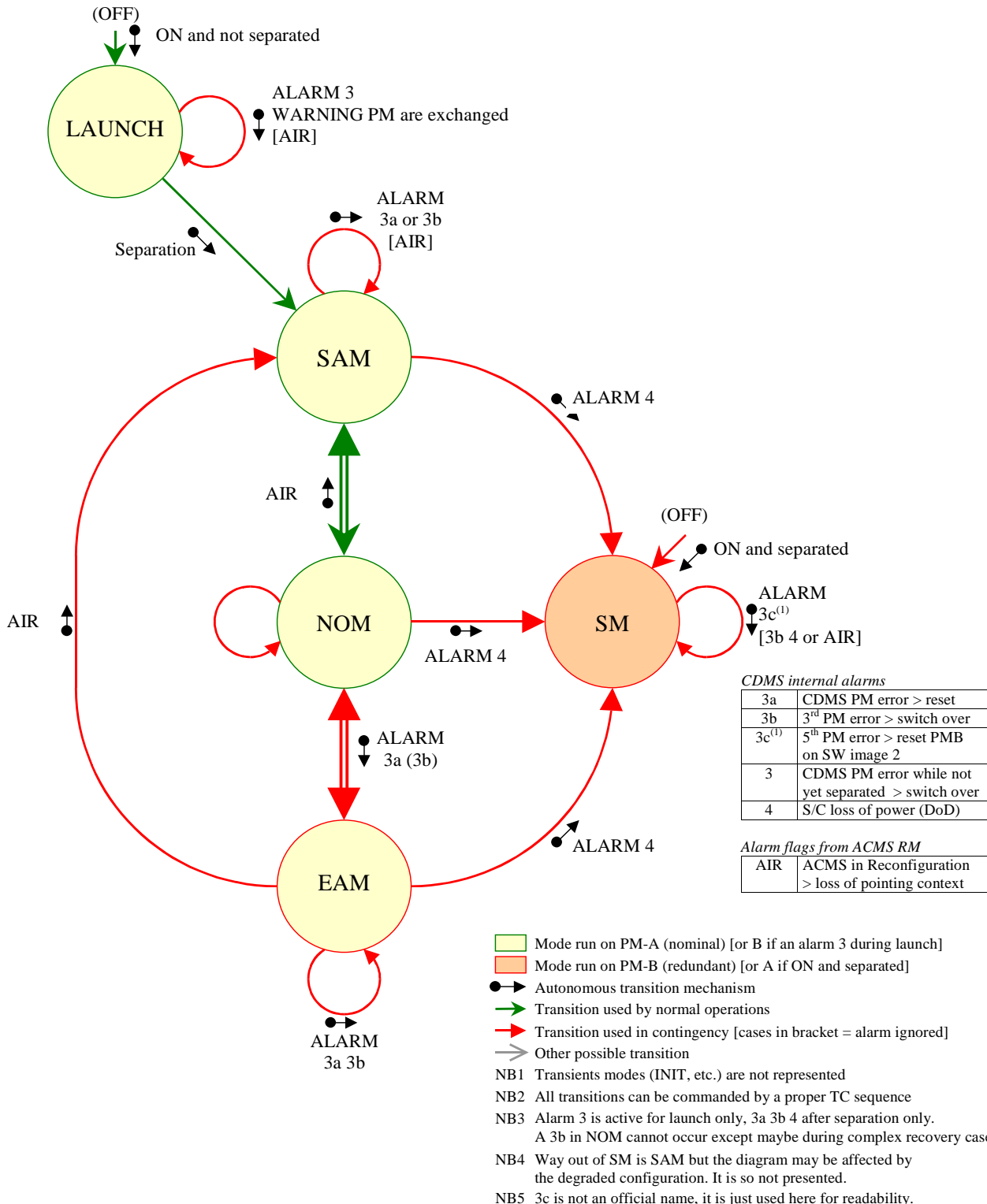

The following figure presents the ACMS operating modes that results in a normal operation context (i.e. not starting from a ACC degraded configurations or not considering contingency recovery cases whose management requires typically the alarms behaviour reprogramming).

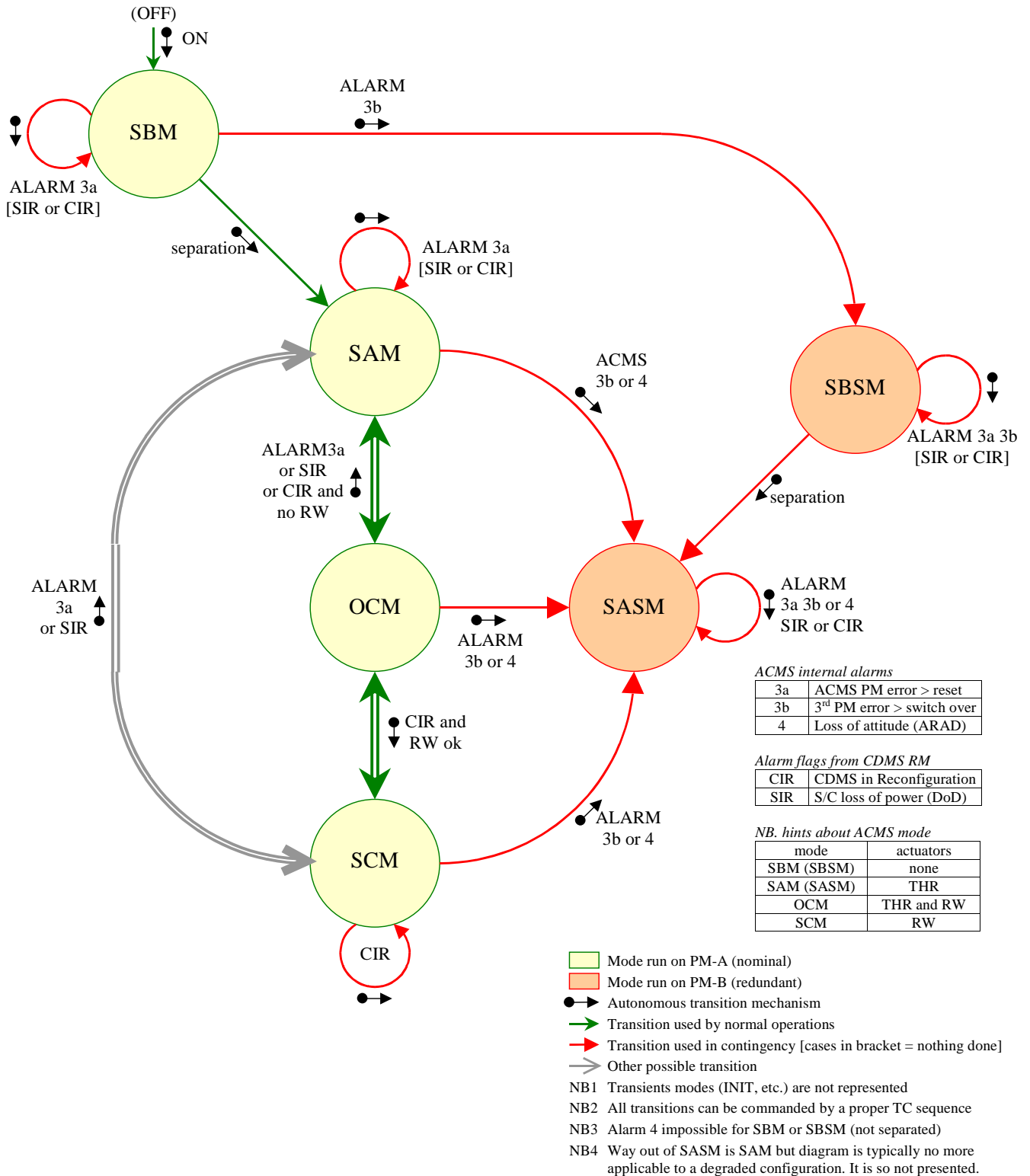

Starting from the above mode diagrams, any CDMS / ACMS mode combination is theoretically possible (i.e. commendable). Operation principle nevertheless limits the configurations to the following:

*CDMS and ACMS modes*

CDMS mode	TC / TM / ANT conf. forced by mode transition	ACMS mode (target)	Basic cases
<i>Launch</i>			
LAUNCH	4k / 5k / LGA 1	SBM / SBSM	Launch
<i>LEOP (Note : those modes will also appears in contingency recovery operations)</i>			
SAM	125 / 500 / LGA1	SAM / SASM	Immediate post launch activities
NOM	4k / 150k / MGA	OCM no RW (Earth)	LEOP activities before RW commissioning
		OCM no RW (any)	OCM1 and OCM2 after launch
		OCM with RW (Earth)	LEOP activities (after RW commissioning)
		SCM (Earth)	LEOP activities (after ACMS commissioning)
		OCM with RW (any)	OCM3 and later OCM
<i>Routine operation</i>			
NOM	4k / 150k / MGA	SCM (any)	Scientific observation
		SCM (Earth)	DTCP (TM temporarily set to 1.5Mbps)
		OCM with RW (any)	Orbit maintenance
		OCM with RW (Earth)	RW biasing (during DTCP)
<i>Contingency (stable final state)</i>			
SAM	125 / 500 / LGA1	SAM / SASM	Contingency with ACMS
EAM	4k / 150k / MGA	SCM (Earth)	Contingency with CDMS
SM	125 / 500 / LGA1	SAM / SASM	Contingency with power
EAM	4k / 150k / MGA	SAM	Contingency with CDMS while in NOM / OCM no RW i.e. during early LEOP activities or some recovery
	NB. all data rates in bps	NB. targets "any" shall be in ARAD limits	

Note1: the table (as the previous diagrams) does not include the transient modes as boot INIT.

Note2: it is not impossible that complex contingency recovery procedures needs some more configuration.

To complement the above elements, the following diagrams and tables summarise the separation strap usage, and naming at different levels.

## Separation strap architecture

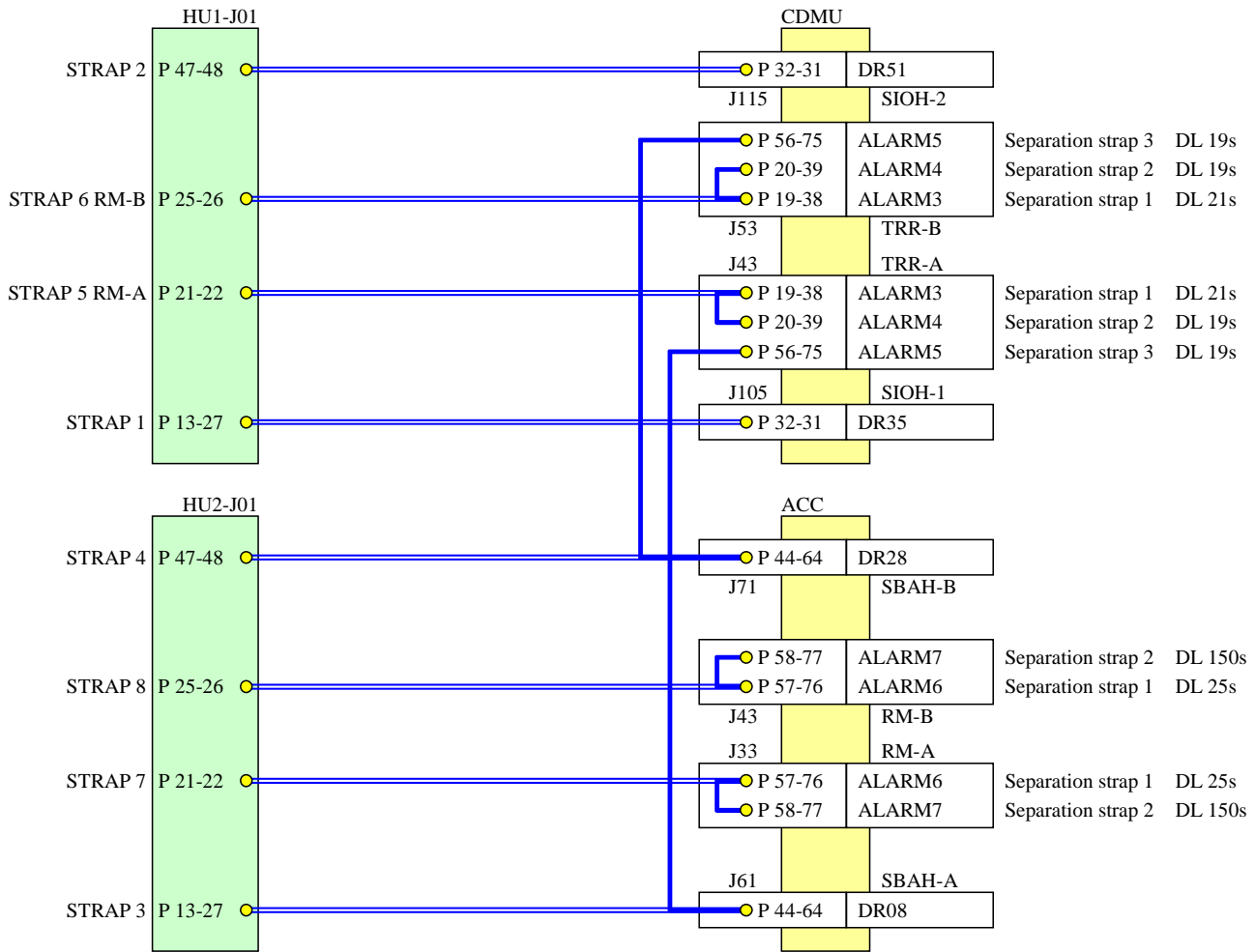

### References

- H-P-4-SES-NT-0009 issue 8 CDMU [HW] User Manual (alarm input usage by PAP)
- H-P-4-SES-IC-0001 issue 9 CDMU EICD (CDMU pin out)
- H-P-4-SES-NT-0031 issue 8 ACC [HW] User Manual (alarm input usage by PAP)
- H-P-4-SES-IC-0002 issue 8 ACC EICD (ACC pin out)
- H-P-NHX-WD-201 issue A5 ACC to ACC interconnection
- H-P-NHX-WD-203 issue A5 ACC to CDMU interconnection
- H-P-NHX-WD-210 issue A6 CDMU to CDMU interconnection
- H-P-NHX-WD-215 issue A5 HU to ACC interconnection
- H-P-NHX-WD-216 issue A5 HU to CDMU interconnection

Erratum : the reference documents are for some obsolete. Separation strap 2 Delay for ACC is so 300s rather than 150s.

# Herschel S/C IST specification

REFERENCE: H-P-2-ASP-SP-0939

DATE: December 20<sup>th</sup> 2007

ISSUE: 6.0

Page : 282

## Strap effect summary

HU	acts on	with result :
Strap 1	CDMU ASW	S/C separated
Strap 2	CDMU ASW	S/C separated
Strap 3	ACC ASW	S/C separated
Strap 4	ACC ASW	S/C separated
Strap 5	PAP0 by RMA PAP1 / PAP2 by RMA PAP3 / PAP4 by RMA	level 4 alarm (enable) level 3 alarm (enable PAP2 disable PAP1) PM relay alarm (enable PAP2 disable PAP1)
Strap 6	PAP0 by RMB PAP1 / PAP2 by RMB PAP3 / PAP4 by RMB	level 4 alarm (enable) level 3 alarm (enable PAP2 disable PAP1) PM relay alarm (enable PAP2 disable PAP1)
Strap 3 AND Strap 5	PAP6 by RMA	Separation [THR A&B LCL ON, TWT A&B HT ON] (enable)
Strap 4 AND Strap 6	PAP6 by RMB	Separation [THR A&B LCL ON, TWT A&B HT ON] (enable)
Strap 7	PAP1 by RMA PAP2 by RMA	Rate anomaly alarm (enable) Attitude anomaly alarm (enable)
Strap 8	PAP1 by RMB PAP2 by RMB	Rate anomaly alarm (enable) Attitude anomaly alarm (enable)



## 17. APPENDIX 9: ALARM CASE VERIFICATION TEST MATRIX

The following table recalls all the possible CDMS/ACMS alarm cases, and where they are tested. Herschel SVM IST column refers to H-P-SP-AI-0084 "Herschel SVM IST test specification", issue 01, dated October 4<sup>th</sup> 2006.

SATELLITE STATE				occurring alarm	synchronisation	number of consecutive alarms necessary to get the situation	TESTED IN		type of situation X = impossible unless multiple failures including from ground operation	number of failure needed (min)	Scenario for having the case with a minimum number of failures (PM failures may be hardware or software)	
before alarm		after alarm					S/C IST	SVM IST				
CDMS	ACMS	CDMS	ACMS									
black : nominal case bleu : transient case orange : degraded case red : abnormal case		red : mode transition done green : mode reinforced black : no action										
LAUNCH	SBM	LAUNCH	SBM	CDMS level 3	CIR	1		5.8.11	8.4.4	nominal	1	CDMS-PMA failure (no 3a / 3b in LAUNCH for CDMS). SVM IST §8.4.5 : test of failure during separation
	SBM	LAUNCH	SBM	ACMS level 3a	AIR	1		5.8.11	8.4.5	nominal	1	ACMS-PMA transient failure.
	SBM	LAUNCH	SBSM	ACMS level 3b	AIR	3		5.8.11	8.4.5	nominal	1	ACMS-PMA permanent failure.
SAM	SAM	SM	SAM	CDMS level 4	SIR	1			8.4.2 step 10	hazardous operation	2	needs multiple failures to get a power outage when the S/C is Sun pointed (no ACMS level 4) and S/C is in SAM mode (minimum power consumption unless to consider a non nominal configuration).
	OCM W-off		SAM			1			hazardous operation	2	needs multiple failures to get a power outage when the S/C is Sun pointed (no ACMS level 4) and S/C is in SAM mode (minimum power consumption unless to consider a non nominal configuration).	
	SASM		SASM			2			X	2	needs multiple failures for ACMS not restoring SUN pointing before battery reserve is out.	
	SAM	SAM	SAM	CDMS level 3a	CIR	1			8.4.2 step 5	nominal	1	CDMS-PMA transient failure.
	OCM W-off		SAM			1			nominal (low probability)	1	CDMS-PMA transient failure. NB. Low probability as SAM/OCM is a transient state on the way to/from NOM/OCM	
	SASM		SASM			2			degraded case	2	CDMS-PMA transient failure (set-up) while ACMS is in severe anomaly (level 4 or 3b)	
	SAM	SAM	SAM	CDMS level 3b	CIR		3		8.4.2 step 5	nominal	1	CDMS-PMA permanent failure
	OCM W-off		SAM				3		hazardous attempt	1	3rd CDMS-PMA transient failure (unit dying) while attempting (for TM/TC rate) to turn the S/C toward Earth to help investigation (i.e. attempt registers not yet cleared on purpose)	
	SASM		SASM				4		X	2	needs two severes failure in a small time delay: one first in ACMS (not yet restored) for being in SASM, then a second with having CDMS PMA permanently failing.	
	SAM	SAM	SASM	ACMS level 4	AIR	1			8.4.1 step 3	nominal	1	ACMS severe failure (loss of attitude)
	OCM W-off		SASM			1			nominal (low probability)	1	ACMS severe failure (loss of attitude). NB. Low probability as SAM/OCM is a transient state on the way to/from NOM/OCM	
	SASM		SASM			2			X	2	needs two severes failure in ACMS in a small time delay: one first (not yet restored) for being in SASM, then a second for loosing again (or being not able to restore) a proper (roughly Sun pointed) attitude.	
	SAM	SAM	SAM	ACMS level 3a	AIR	1			8.4.2 step 4	nominal	1	ACMS-PMA transient failure
	OCM W-off		SAM			1			nominal (low probability)	1	ACMS-PMA transient failure. NB. Low probability as SAM/OCM is a transient state on the way from/to SAM/SAM to/from NOM/SCM	
	SASM		SASM			2			degraded case (low probability)	2	ACMS-PMB transient failure (set-up), after ACMS has undergone one first and not yet recovered severe anomaly.	
SAM	SAM	SASM	ACMS level 3b	AIR		3			nominal	1	ACMS-PMA permanent failure	
OCM W-off		SAM				3		nominal (low probability)	1	ACMS-PMA permanent failure. NB. Low probability as SAM/OCM is a transient state on the way to/from NOM/OCM		
SASM		SASM				4		X	2	needs two severes failure in ACMS in a small time delay: one first (not restored) for being in SASM, then a second with having ACMS PMB permanently failing.		

# Herschel S/C IST specification

REFERENCE: H-P-2-ASP-SP-0939



DATE: December 20<sup>th</sup> 2007

ISSUE: 6.0

Page : 284

SATELLITE STATE				occurring alarm	synchronisation	number of consecutive alarms necessary to get the situation	TESTED IN		type of situation X = impossible unless multiple failures including from ground operation	number of failure needed (min)	Scenario for having the case with a minimum number of failures (PM failures may be hardware or software)
before alarm		after alarm					S/C IST	SVM IST			
CDMS	ACMS	CDMS	ACMS								
black : nominal case bleu : transient case orange : degraded case red : abnormal case		red : mode transition done green : mode reinforced black : no action									
NOM	SCM	SM	SAM	CDMS level 4	SIR	1	5.8.6.7		hazardous operation	2	needs multiple failures or an operation error has operating the S/C at full load while in Moon eclipse to get a power outage while the S/C is Sun pointed (no ACMS level 4).
	OCM		SAM			1		hazardous operation	2	needs multiple failures or an operation error has operating the S/C at full load while in Moon eclipse to get a power outage while the S/C is Sun pointed (no ACMS level 4).	
	SCM	EAM	SCM (Earth)	CDMS level 3a	CIR	1	5.8.12 5.8.6.3	8.4.2 step 1, 7	nominal	1	CDMS-PMA transient failure.
	OCM W-on		SCM (Earth)			1		nominal	1	CDMS-PMA transient failure.	
	OCM W-off		SAM			1		nominal (low probability)	1	ACMS-PMA transient failure. NB. Low probability as SAM/OCM is a transient state on the way from/to SAM/SAM to/from NOM/SCM	
	SCM	EAM	SCM (Earth)	CDMS level 3b	CIR		3		X		needs CDMS commanded back into operation without clearing RM attempt registers after two 3a alarms.
	OCM W-on		SCM (Earth)				3		X	needs CDMS commanded back into operation without clearing RM attempt registers after two 3a alarms.	
	OCM W-off		SAM				3		hazardous attempt	1	3rd CDMS-PMA transient failure (unit dying) while having restored NOM/OCM W-off to point the Earth (TC rate) to help investigation (i.e. attempt registers not yet cleared on purpose)
	SCM	SAM	SASM	ACMS level 4	AIR	1	5.8.6.5		nominal	1	ACMS severe failure (loss of attitude)
	OCM		SASM			1		8.4.1 step 1	nominal	1	ACMS severe failure (loss of attitude)
	SCM	SAM	SAM	ACMS level 3a	AIR	1			nominal	1	ACMS-PMA transient failure
	OCM		SASM			1		nominal	1	ACMS-PMA transient failure	
	SCM	SAM	SASM	ACMS level 3b	AIR		4		X		needs ACMS commanded back into operation without clearing RM attempt registers after two 3a alarms.
	OCM		SASM				4		hazardous attempt	1	3rd ACMS-PMA transient failure (unit dying) while having restored NOM/OCM W-off to point the Earth (TC rate) to help investigation (i.e. attempt registers not yet cleared on purpose)
EAM	SCM (Earth)	SM	SAM	CDMS level 4	SIR	2		8.4.2 step 8	X	3	needs two severes failure in a small time delay: one first (not yet restored) in CDMS-PM for being in EAM, then multiple in ACMS to have a full loss of power and energy.
	SAM		SAM			2		X	3	needs two severes failure in a small time delay: one first (not yet restored) in CDMS-PM for being in EAM, then multiple in ACMS to have a full loss of power and energy.	
	SCM (Earth)	EAM	SCM (Earth)	CDMS level 3a	CIR	2	5.8.12 5.8.6.4		nominal	1	CDMS-PMA permanent failure (a 2nd 3a is attempted from 2nd RN, next will be 3b).
	SAM		SAM			2		nominal (low probability)	1	CDMS-PMA permanent failure while the first 3a alarm occurred during a low probability SAM/OCM.	
	SCM (Earth)	EAM	SCM (Earth)	CDMS level 3b	CIR		3	5.8.12 5.8.6.4	nominal	1	CDMS-PMA permanent failure (a 2nd 3a is attempted from 2nd RN, next will be 3b).
	SAM		SAM				3		nominal (low probability)	1	CDMS-PMA permanent failure while the first 3a alarm occurred during a low probability SAM/OCM.
	SCM (Earth)	SAM	SASM	ACMS level 4	AIR	2		8.4.2 step 2	degraded case	2	ACMS severe failure (loss of attitude), short after CDMS-PMA has undergone a transient failure (i.e. not yet restore)
	SAM		SAM			2		degraded case (low probability)	2	ACMS severe failure (loss of attitude), short after CDMS-PMA has undergone a transient failure (i.e. not yet restore) which occurred during a low probability SAM/OCM.	
	SCM (Earth)	SAM	SAM	ACMS level 3a	AIR	2			degraded case	2	ACMS-PMA transient failure, short after CDMS-PMA has undergone a similar problem (i.e. not yet restore)
	SAM		SAM			2		degraded case (low probability)	2	ACMS-PMA transient failure, short after CDMS-PMA has undergone a similar problem (i.e. not yet restore) which occurred during a low probability SAM/OCM.	
	SCM (Earth)	SAM	SASM	ACMS level 3b	AIR		4		X		needs ACMS commanded back into operation without clearing RM attempt registers
	SAM		SASM				4		X	needs ACMS commanded back into operation without clearing RM attempt registers	

SATELLITE STATE				occurring alarm	synchronisation	number of consecutive alarms necessary to get the situation	TESTED IN		type of situation X = impossible unless multiple failures including from ground operation	number of failure needed (min)	Scenario for having the case with a minimum number of failures (PM failures may be hardware or software)		
before alarm		after alarm					S/C IST	SVM IST					
CDMS	ACMS	CDMS	ACMS										
black : nominal case bleu : transient case orange : degraded case red : abnormal case		red : mode transition done green : mode reinforced black : no action											
SM	SAM	SM	SAM	CDMS level 4	SIR	1	2			possibly cyclic after a level 4	2	DOD alarms not cleared after CCS 0 retry delay	
	SASM		SASM							cyclic in SOHO case	3	Typical repetitive situation in going out of a SOHO case	
	SAM	SM	SAM	CDMS level 3a	CIR	2		8.4.2 step 10bis		degraded case (low probability)	3	needs CDMS-PMB transient failure (set-up) a short time after (not yet restored) a severe multiple failure leading to S/C loss of power and energy	
	SASM		SASM			3				degraded case in SOHO case	3	A specific PAP exists nevertheless in CDMS for this case(SM boot with SW image 2)	
	SAM	SM	SAM	CDMS level 3b	CIR		4			X	3	needs CDMS-PMB permanent failure (set-up) a short time after (not yet restored) a severe multiple failures leading to S/C loss of power and energy (level 4)	
	SASM		SASM				5			X	3		
	SAM	SM	SASM	ACMS level 4	AIR	2				X		3	needs double CDMS and ACMS severe failure (or entry in SOHO case if ACMS failure triggered by lack of power)
	SASM		SASM			3				cyclic in SOHO case	3	Typical repetitive situation in going out of one SOHO case	
	SAM	SM	SAM	ACMS level 3a	AIR	2						3	needs ACMS-PM transient failure (set-up) after severe multiple failures leading to S/C loss of power and energy (level 4)
	SASM		SASM			3				degraded case in SOHO case	3		
SAM	SM	SASM	ACMS level 3b	AIR		4				X		3	needs ACMS-PM permanent failure after severe multiple other failures leading to S/C loss of power and energy (level 4)
SASM		SASM				4			X				
OFF	OFF	SM	SAM	SOHO	SIR	1				cyclic in SOHO case	3	Restart condition after a full loss of power.	

 no need to be tested  
 not a priority for test

For information, here follows a summary of the transitions tested in the frame of Herschel SVM IST (see H-P-SP-AI-0084 "Herschel SVM IST test specification", issue 01, dated October 4<sup>th</sup> 2006 for details).

### FDIR scenario 1

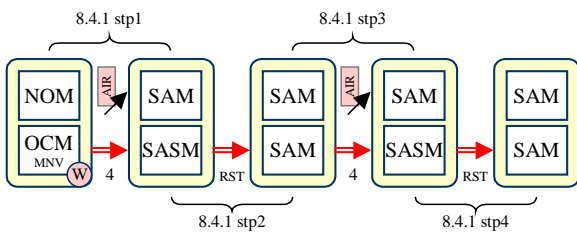

## FDIR scenario 2

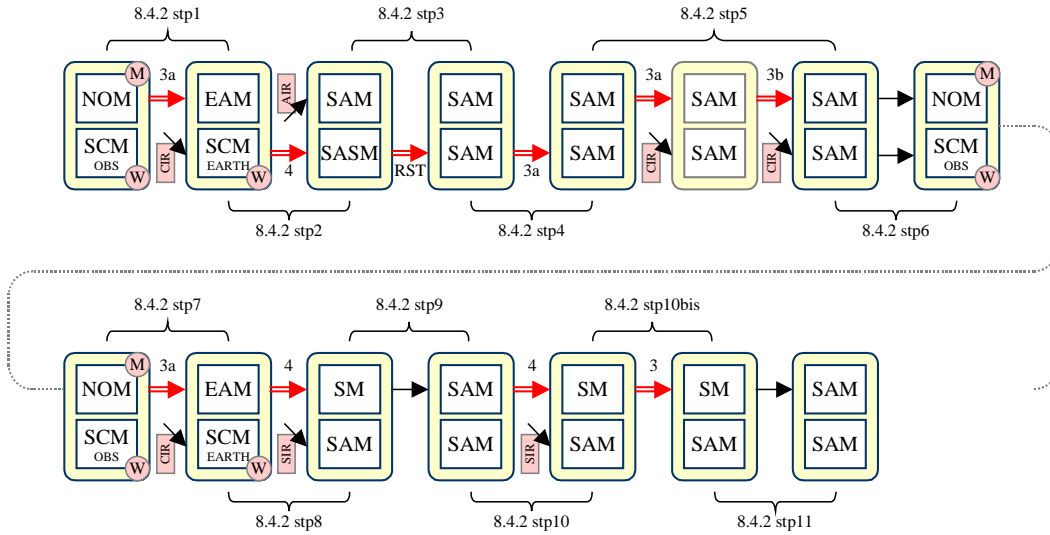

## FDIR scenario 3

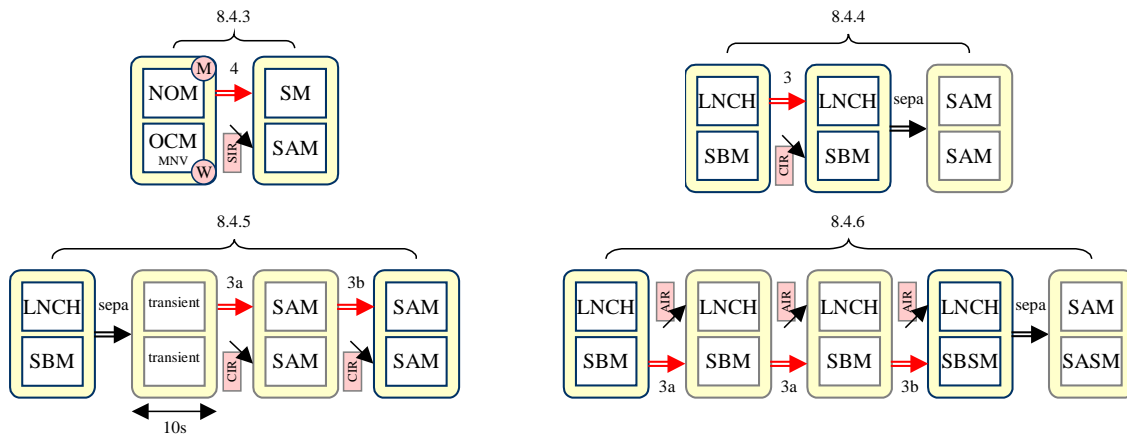

## 18. APPENDIX 10: AVM S/C IST APPLICABILITY MATRIX

### 18.1. SEQUENCE PRIORITY

The AVM S/C IST test shall be realised in a finite time window, starting from newly developed procedures (even if inherited from lower level tests). To manage the time contingency, the sequences shall be executed with the following priority:

priority	sequence	ref.	PM	Units	INST	note
1a	Launch	§5.8.2	A1	A	A	
1b	S/C Reconfiguration	§5.8.6	AB1	<b>A**</b>	<b>A***</b>	
1c	Degraded cases	§5.9.2	AB1	A	A	
		§5.9.3	AB1	<b>A**</b>	<b>A***</b>	
1d	DTCP worst case scenario	§5.8.8	<b>A1*</b>	<b>A**</b>	<b>A***</b>	
1e	REFERENCE Mission Scenario	§5.8.9	A1	A	A	
2a	Instrument commissioning	§5.8.4	A1	A	<b>A***</b>	SPIRE
			A1	B	<b>A***</b>	PACS
			B1	A	<b>A***</b>	HIFI
			B1	B	<b>A***</b>	Parallel
2b	Mode transitions	§5.8.5	A	A	A	
<b>1f / 3a *</b>	Launch clean run	§5.8.10	A1	A	A	
3b	CDMS management	§5.8.7	A2	A	A	
3c	S/C commissioning	§5.8.3	A1	A&B	<b>A***</b>	
3d			B1	B&A	<b>A***</b>	

The PM / Units / INST column detail the applicable configuration for the used CMDU and ACC PM and software image (PM), the unit in used (Units) not considering the instruments, and the unit in use considering the instruments (INST). This applicability matrix shall be read with the following definitions:

**A1\*** : this sequence shall be nominally tested in B2 configuration (PM-B image 2). This may be considered as a priority 3e in frame of S/C AVM IST test, unless this simplifies the procedure / test management.

**A\*\*** : this sequence shall be nominally tested in unit B configuration (SVM units). This may be considered as a priority 3f in frame of S/C AVM IST test, unless this simplifies the procedure / test management.

**A\*\*\*** : the AVM configuration does not allow to use an another configuration.

**1f / 3a\*** : considering risks associated to this sequence (no observability on the satellite for a quite long period), it is not considered possible to run this sequence on the flight model before this sequence has been debugged and successfully run on the AVM. It may be so considered as a priority 1. In the other hand, this sequence is fully similar on Herschel and Planck on the critical part, that is the satellite control recovery after separation. Before the separation, this sequence is strictly identical to the Launch sequence. Then it is considered a priority 1 to run successfully this sequence either on Herschel or Planck AVM. But this is a priority 3 run this sequence on both Herschel and Planck AVM.

The priority 1 tests are the one that shall be in any case successful to consider the AVM S/C IST successful.

The priority 2 tests are the one that shall be attempted and debugged at a minimum level (see sequence dedicated paragraphs) in the frame of the test. A successful clean run may be trade against schedule time.

The priority 3 tests are the one that may be fully trade against schedule time.

## 18.2. CONSIDERED SEQUENCE ADAPTATION FOR AVM TEST

### 18.2.1. LAUNCH SEQUENCE

The AVM configuration can fully support the test, except for the instrument launch lock setting / verification.

The associated operation shall be masked.

### 18.2.2. S/C RECONFIGURATION, DEGRADED CASES, DTCP WORST CASE SCENARIO

The AVM configuration can fully support those tests, except for the instrument being in the wanted observation modes, on the wanted units (i.e. B).

The sequence shall be run with masking the instrument observation operations, and leaving the instrument to be PRIME, in STBY.

This limits nevertheless the scope of the emergency OBCP verification, and the instrument teams may suggest on a case by case basis to be agreed before TRR, an alternative configuration for the instrument to be PRIME for the PFM sequence.

### 18.2.3. REFERENCE MISSION SCENARIO

The AVM configuration can fully support this test, except for the instrument being in the wanted observation modes, which may be different from the PFM test to take into account the limitation of the AVM units.

Specifically, HIFI will be not activated during the RMS on AVM (too much limitation, it will be left in stand-by). The test slot will be used for testing a specific sequence with SPIRE in spectrometer mode (not considered for RMS on the PFM).

## 18.2.4. INSTRUMENT COMMISSIONING

The AVM configuration can fully support this test, except for the instrument being in the wanted observation modes on the wanted unit.

This sequence shall be run at worst with masking the instrument observation operations, and leaving the instrument to be PRIME, in STBY.

This defines the minimum objective of the test, as the validation of the procedures needed to set the S/C in A1/B, B1/A and B1/B (PM/Units) configuration.

## 18.2.5. MODE TRANSITIONS

The AVM configuration can fully support this test, except for the instrument being in the wanted observation modes on the wanted unit.

This sequence shall be run at worst with masking the instrument observation operations, and leaving the instrument to be PRIME, in STBY.

This limits nevertheless the scope of the emergency OBCP verification, and the instrument teams may suggest on a case by case basis to be agreed before TRR, an alternative configuration for the instrument to be PRIME for the PFM sequence.

## 18.2.6. LAUNCH CLEAN RUN

The AVM configuration can fully support the test, except for the instrument launch lock setting / verification.

The associated operation shall be masked.

## 18.2.7. CDMS MANAGEMENT

The AVM configuration can fully support those tests, except for the instrument being in the wanted observation modes, on the wanted units (i.e. B).

The sequence shall be run with masking the instrument observation operations, and leaving the instrument to be PRIME, in STBY.

The instrument teams may suggest on a case by case basis to be agreed before TRR, an alternative configuration for the instrument to be PRIME for the PFM sequence.

## 18.2.8. S/C COMMISSIONING

The AVM configuration can fully support those tests, except for the instrument "B" ICU/DPU being available for the 1553 link test.

The sequence shall be run with masking the instrument "B" ICU/DPU 1553 link test.

## 19.APPENDIX 11: EGSE CONFIGURATION ELEMENTS

### 19.1. S/C SKIN PLUG CONFIGURATION

The following table details the S/C skin plug usage in relation with the different S/C IST sequences:

connector bracket identification	connector reference	unit or function	SCOE configuration as a function of S/C IST test sequence	Launch sequence RMS	INST commissioning Mode transition S/C reconfiguration Launch mode robustness CDMS management DTCP worst case scnr	NOM mode robustness	Clean run	Comments
PU1	J01	M	Umbilical connection	TMTC DFE	TMTC DFE	TMTC DFE	"OPEN"	
PU2	J02	R					(during main sequence)	
SK01A	J01	M	Solar Array connector (SAS input)	POWER SCOE (LPS then SAS config)	POWER SCOE (SAS)	POWER SCOE (SAS)	Solar Array connected (if present)	SA1, sections 1, 4, 7, 10, 13, 16, 19, 22, 25, 28 SA2, sections 2, 5, 8, 11, 14, 17, 20, 23, 26, 29 SA3, sections 3, 6, 9, 12, 15, 18, 21, 24, 27, 30
	J05	M						
	J02	M						
	J06	R						
	J03	M						
SK1B	J07	R						
	J09	M	Flight Battery power jumper (PCDU side = BATSIM input)	FLIGHT PLUG (FM battery connected)	POWER SCOE (BATSIM)	POWER SCOE (BATSIM)	FLIGHT PLUG (FM battery connected)	
	J10	R						
	J11	M	BDR AIT ON/OFF DTC (emergency S/C OFF)	LPS SCOE	LPS SCOE	LPS SCOE	FLIGHT PLUG	
SK02	J12	R						
	J01	M	CDMS 1553 bus jumper (S/C bus monitoring)	BUS MONITOR	BUS MONITOR	BUS MONITOR and CDMU SCOE (jamming)	FLIGHT PLUG	
	J02	R						
	J03	M	ACMS 1553 bus jumper (S/C bus monitoring)	ACMS SCOE (bus monitor)	ACMS SCOE (bus monitor)	ACMS SCOE (bus monitor)	FLIGHT PLUG	
	J04	R						
	J05	M	LV / THR FCV cmd safety plugs (safe plug with loads)	ACMS SCOE	ACMS SCOE	ACMS SCOE	TEST LOADS	
	J06	R						
	J07	M	PCS TANK sensor jumpers (simulation input)	ACMS SCOE	ACMS SCOE	ACMS SCOE	FLIGHT PLUG (sensors connected)	
	J08	M	THR thermocouple and LV status (simulation input)	ACMS SCOE	ACMS SCOE	ACMS SCOE	FLIGHT PLUG (sensors connected)	
	J09	M	CDMU and ACC EEPROM quick reprogramming input	FLIGHT CAP	FLIGHT CAP	FLIGHT CAP	FLIGHT CAP	
	J10	R						
	J11	R	THR thermocouple and LV status (simulation input)	ACMS SCOE	ACMS SCOE	ACMS SCOE	FLIGHT PLUG (sensors connected)	
	J12	M	THR heaters cmd safety plugs (safe plug with load)	ACMS SCOE	ACMS SCOE	ACMS SCOE	TEST LOADS	
J13	R							
J14	M	STR ON/OFF STS signal jumper (simulation input)	FLIGHT PLUG (STR connected)	FLIGHT PLUG (STR connected)	FLIGHT PLUG (STR connected)	FLIGHT PLUG (STR connected)		
J15	M							
J16	M	GYRO ON/OFF STS signal jumper (simulation input)	FLIGHT PLUG (GYRO connected)	FLIGHT PLUG (GYRO connected)	FLIGHT PLUG (GYRO connected)	FLIGHT PLUG (GYRO connected)		
J17	M							
SK03	J01	M	FTC XPND aux. outputs and TWTA safety plug	GROUND CAP	GROUND CAP	GROUND CAP	FLIGHT PLUG (with beta protection strap)	
	J02	M						
SK04	J01	M	RWL1 signal jumper	FLIGHT PLUG (RWL connected)	FLIGHT PLUG (RWL connected)	FLIGHT PLUG (RWL connected)	FLIGHT PLUG (RWL connected)	
	J02	M	RWL2 signal jumper					
	J03	M	RWL3 signal jumper					
	J04	M	RWL4 signal jumper					
SK05	J01	M	CRS signal jumper (simulation input)	FLIGHT PLUG (CRS connected)	FLIGHT PLUG (CRS connected)	FLIGHT PLUG (CRS connected)	FLIGHT PLUG (CRS connected)	
	J02	M						
	J03	M	GYRO test plug (stimulation)					
	J04	M	CRS stimulation input					
	J05	M	AAD signal jumper (simulation input)					
	J06	M	SAS 1and 2 signal jumpers (simulation input)					
	J07	R						
	J08	R	AAD signal jumper (simulation input)					
SK06	J01	M	STR stimulation input	ACMS SCOE	ACMS SCOE	ACMS SCOE	FLIGHT CAP	
	J02	M						
ANT	LGA1	M	Low gain antenna (Earth)	RF SCOE	RF SCOE	RF SCOE	RF SCOE	
	LGA2	M	+X looking LGA					
	LGA3	M	(used for Launch and SM only)					
	MGA	M	Medium gain antenna (Earth)					

Values in red are delta with respect to most common test configuration.

Note: the above configuration holds for PFM tests. For AVM, the need to simulate some of the ACMS sensors and actuators leads to a specific configuration.

WARNING: the above configuration holds for test at ambient. It shall not be copied and pasted for one TVTB test.



## 19.2. S/C LATCHING RELAYS

The following table recalls the latching relays and switches present in the S/C design (SVM), and the configuration in which they shall be set the specified test PM / Units configuration.

S/C latching relays	TEST configuration :	PM A				PM B				command available on MAPO
		UNITS A		UNITS B		UNITS A		UNITS B		
		SW1	SW2	SW1	SW2	SW1	SW2	SW1	SW2	
CDMU	RMA enable	Enabled	Enabled	Enabled	Enabled	Enabled	Enabled	Enabled	Enabled	YES
	RMB enable	Enabled	Enabled	Enabled	Enabled	Enabled	Enabled	Enabled	Enabled	YES
	OBT select	OBT A	OBT A	OBT B	OBT B	OBT A	OBT A	OBT B	OBT B	YES
	PM select	PM A	PM A	PM A	PM A	PM B	PM B	PM B	PM B	YES
	PM A Bit 0 Software image	SW image1	SW image2	SW image1	SW image2	SW image1	SW image2	SW image1	SW image2	YES
	PM A Bit 1 SOHO case (boot in SM)	0 (*)	0 (*)	0 (*)	0 (*)	0 (*)	0 (*)	0 (*)	0 (*)	YES
	PM B Bit 0 Software image	SW image1	SW image2	SW image1	SW image2	SW image1	SW image2	SW image1	SW image2	YES
	PM B Bit 1 SOHO case (boot in SM)	0 (*)	0 (*)	0 (*)	0 (*)	0 (*)	0 (*)	0 (*)	0 (*)	YES
	PM A ON/OFF	ON	ON	ON	ON	OFF	OFF	OFF	OFF	YES
	PM B ON/OFF	OFF	OFF	OFF	OFF	ON	ON	ON	ON	YES
	WD enable A	ON	ON	ON	ON	ON	ON	ON	ON	YES
	WD enable B	ON	ON	ON	ON	ON	ON	ON	ON	YES
	PCDU	I/F A ON/OFF	ON	ON	OFF	OFF	ON	ON	OFF	OFF
I/F B ON/OFF		OFF	OFF	ON	ON	OFF	OFF	ON	ON	
ACC	RMA enable	Enabled	Enabled	Enabled	Enabled	Enabled	Enabled	Enabled	Enabled	YES
	RMB enable	Enabled	Enabled	Enabled	Enabled	Enabled	Enabled	Enabled	Enabled	YES
	OBT select	OBT A	OBT A	OBT B	OBT B	OBT A	OBT A	OBT B	OBT B	
	PM select	PM A	PM A	PM A	PM A	PM A	PM A	PM A	PM A	
	PM A Bit 0 Software image	SW image1	SW image2	SW image1	SW image2	SW image1	SW image2	SW image1	SW image2	
	PM A Bit 1 Boot mode (S/N)	Nominal (*)	Nominal (*)	Nominal (*)	Nominal (*)	Survival (*)	Survival (*)	Survival (*)	Survival (*)	
	PM B Bit 0 Software image	SW image1	SW image2	SW image1	SW image2	SW image1	SW image2	SW image1	SW image2	
	PM B Bit 1 Boot mode (S/N)	Survival (*)	Survival (*)	Survival (*)	Survival (*)	Nominal (*)	Nominal (*)	Nominal (*)	Nominal (*)	
	PM A ON/OFF	ON	ON	ON	ON	OFF	OFF	OFF	OFF	
	PM B ON/OFF	OFF	OFF	OFF	OFF	ON	ON	ON	ON	
	WD enable A (CDMU separated)	(CDMS)	(CDMS)	(CDMS)	(CDMS)	(CDMS)	(CDMS)	(CDMS)	(CDMS)	
	WD enable B (CDMU separated)	(CDMS)	(CDMS)	(CDMS)	(CDMS)	(CDMS)	(CDMS)	(CDMS)	(CDMS)	
	CIR	(CDMS)	(CDMS)	(CDMS)	(CDMS)	(CDMS)	(CDMS)	(CDMS)	(CDMS)	set only
SIR	(CDMS)	(CDMS)	(CDMS)	(CDMS)	(CDMS)	(CDMS)	(CDMS)	(CDMS)	set only	
AIR	(ACMS)	(ACMS)	(ACMS)	(ACMS)	(ACMS)	(ACMS)	(ACMS)	(ACMS)		
TTC-RF	RF Switch 1	B	B	B	B	B	B	B	B	YES
	RF Switch 2	B	B	B	B	B	B	B	B	YES
	RF Switch 3	B	B	B	B	B	B	B	B	YES
	RF Switch 4	B	B	B	B	B	B	B	B	YES
	XPND 1 Tx RF	OFF	OFF	OFF	OFF	OFF	OFF	OFF	OFF	YES
	XPND 2 Tx RF	OFF	OFF	OFF	OFF	OFF	OFF	OFF	OFF	YES

Notes:

For the (\*) subscripted cases, the setting is modified as part of the S/C autonomous reconfiguration.

The red colour marks the delta-configuration from nominal PMA, UNITS A, SW1 configuration.

For relays which cannot be commanded from MAPO, the CDMU SW shall be active for modifying the relays state, then the turn ON configuration is determined from state at previous turn OFF.

The MAPO command for "WD enable A" shall be sent on VC0, and VC1 for "WD enable B" (same command reference).

The grey colour / italic marks relays which initial state is managed by the listed sub-system.

The TTC relays and switches position change with S/C operations, but initial position for one cold start shall be coherent with the "unit in use" table as loaded with default EEPROM values. An alternative is to confirm the switches and relays position with service 115 TC after boot, so that the table flags are corrected.

## 20.APPENDIX 12: TEST MTL FOR MODE TRANSITION AND S/C RECONFIGURATION

### 20.1. BACKGROUND "MTL TEST PATTERN" SUBSCHEDULE

To verify the MTL correct operation during transition tests (mode transition, S/C reconfiguration), the hereafter MTL TC "test pattern" shall be considered.

The test pattern answers the IST specification of having a background emission of MTL TC at a 1 TC/s rate (at least). To get a such intensive background MTL, and to keep the MTL size limited, the chosen compromise is to build a MTL from 2 minutes "windows" of intensive 1 TC/s once every 15 minutes.

This means that the test sequence critical transition commands or alarm triggers shall be synchronised o occur during those windows.

Between the intensive commanding windows, a second subschedule shall issue an another frame of TC at 1 TC per minute rate. This subschedule is considered for providing a "MTL still alive" marker of activity.

The test pattern shall be built from a cycle of service 17 commands.

The cycles shall be inverted between the 2 subschedule (second and minute MTL) to prevent that the same unit receive two TC(17,1) in the same second (this might cause the second TC rejection).

Note that the "minute" subschedule :

- begins with ACMS, so that some of the ACMS "ping" shall occur in the same MTL slot than the slew commands from the scanning law (which shall be set in time tag with :00s).
- is not stopped during the windows, so that the case of 2 TC to ACMS in the same MTL slot occurs periodically in the middle of the 1 TC/s window.

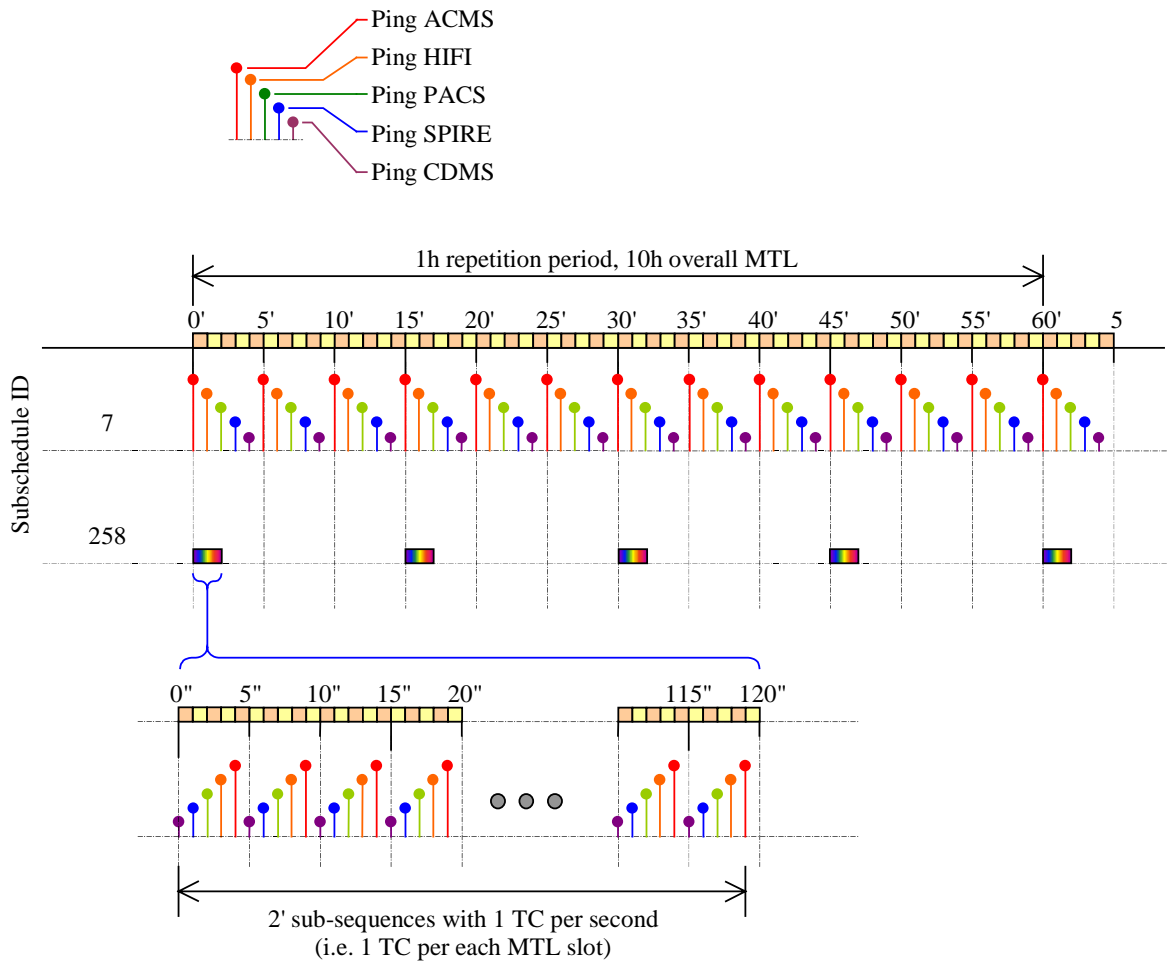

The 1s TC subschedule is affected with a transient subschedule ID (>256) to prevent spurious activation when the MTL software service is restarted. The 1min. TC subschedule is in turn affected with a permanent subschedule ID, so to experience this kind of operation and provide a background "MTL is alive" signal.

This MTL represents 528 TC per hour, that is 5280 TC to be loaded to cover a 10h test session.

# Herschel S/C IST specification

REFERENCE: H-P-2-ASP-SP-0939

DATE: December 20<sup>th</sup> 2007

ISSUE: 6.0

Page : 294

---

END OF DOCUMENT