

Coupe A-A

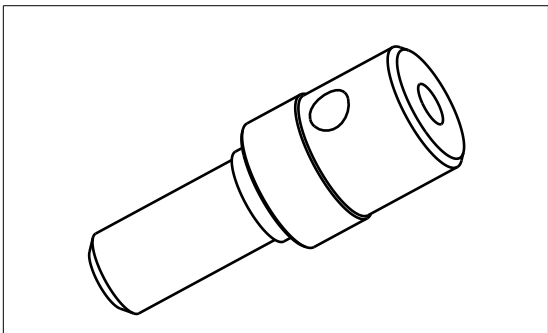
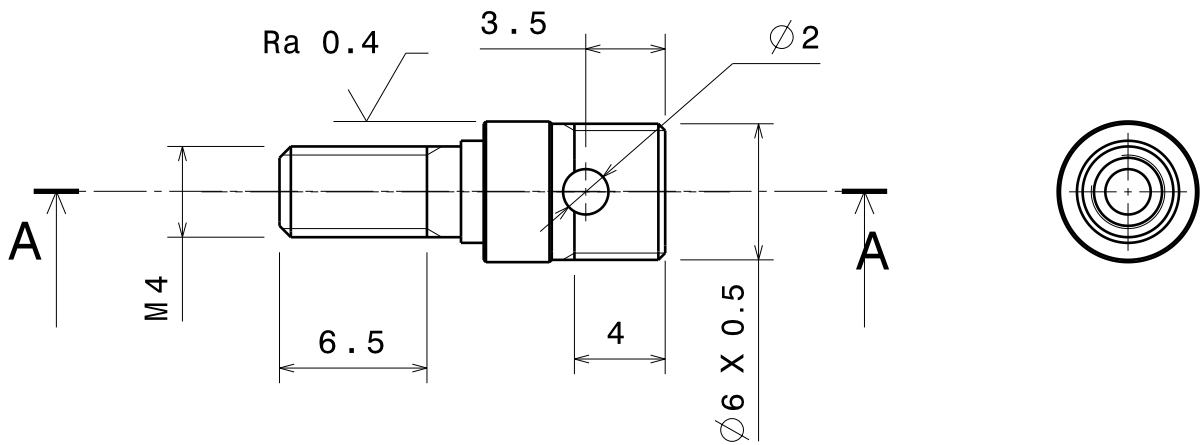
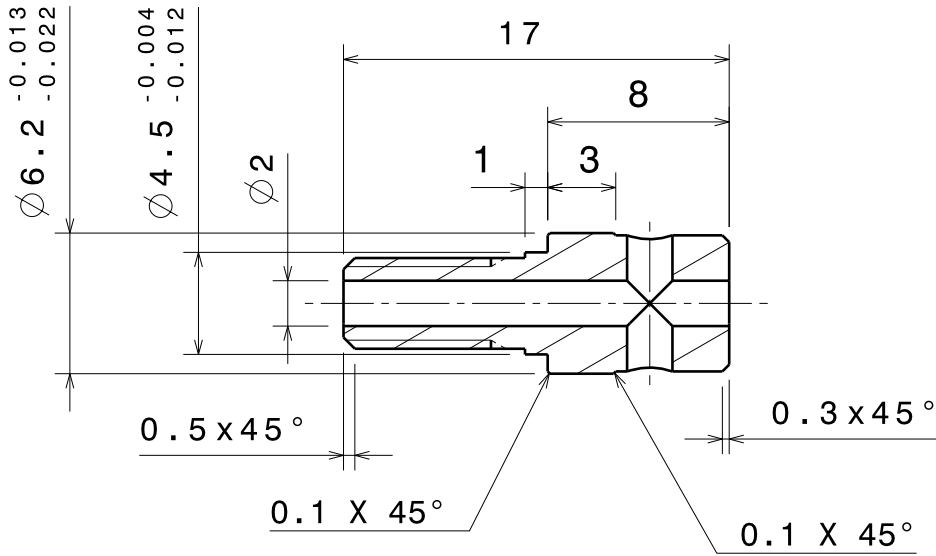

TRAITEMENT DE SURFACE :
 - ALODINE - Doc Ref : SPI-MEC.00.PM.02
 APRES TRAITEMENT NUFLON M2

TRAITEMENT DE RELAXATION :
 - Doc Ref : SPI-MEC.00.PM.01

L.A.M.			Matière	6061 T6		Echelle	3	Format	A4	Rugosité	1.6	Masse Estimée
			Tolerances :	linéaires : JS 11 angulaires : +/- 5 arc min		Numéro / Projet		Herschel - SPIRE				
			* Cote finie hors tout		Date		Nom		Désignation			
			Dessin		24-06-02		P. LAURENT		Mecanisme FTS			
			Contrôle						LATCH - Vis alu			
			Approb.									
D		11-05-05	J.C. BLANC	Laboratoire d'Astrophysique de Marseille		Numéro		SPI-MEC-81-DD-11-D			Feuille No	
C		28-11-02	P. LAURENT			1/1						
B		04-10-02	P. LAURENT									
Ind.	Modification	Date	Nom									