

TRAITEMENT DE SURFACE : NIKELAGE  
 -Doc Ref:  
 Ce traitement sera réalisé après finition de la  
 pièce en accord avec plan SPI-MEC-51-DO-01-C

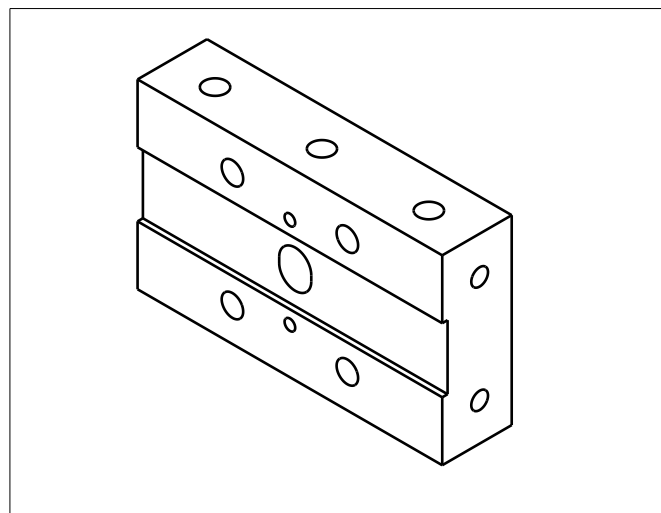

<b>L.A.M.</b>		Matière FER PUR		Echelle 2	Format A3	Rugosité 1.6	Masse Estimée 22 g
		Tolérances : linéaires : JS 11 angulaires : +/- 5 arc min					
* Cote finie hors tout		Date		Numéro / Projet			
		J M A		Herschel - SPIRE			
Dessin		06-06-05		Blanc j.c.			
Contrôle							
Approb.							
				Designation			
				Mecanisme FTS			
				Bout - Contrôle			
				Laboratoire d'Astrophysique de Marseille		Numéro	
				SPI-MEC-51-DS-07-A		Feuille No	
Ind.		Modification		Date		Nom	
						1/1	