

TRAITEMENT DE SURFACE :
- ALODINE - Doc Ref : SPI-MEC.00.PM.02
- O.A.D. ép 40μ

TRAITEMENT DE RELAXATION :
- Doc Ref : SPI-MEC.00.PM.01

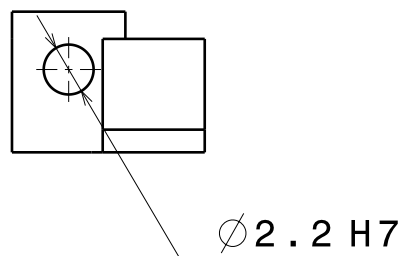

Nota : Les hélicoils M 2.5 seront montés à 0.5 mm de la face A.
La face A sera éventuellement reprise lors de l'intégration du Latch.

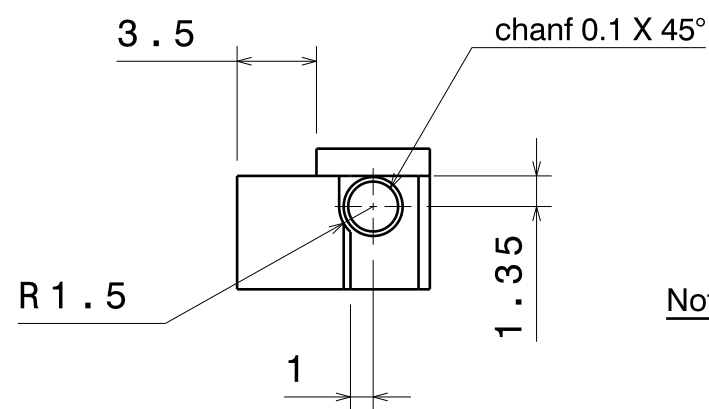
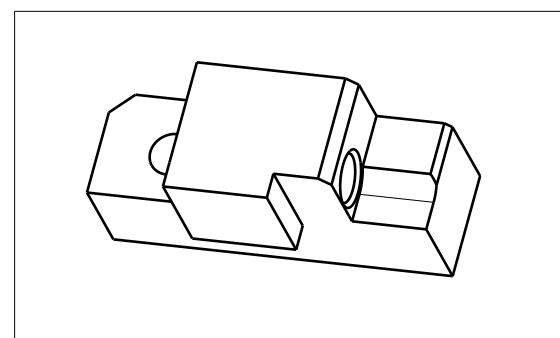

L.A.M.			Matière	6061 T 651	Echelle 3	Format A4	Rugosité 1.6	Masse Estimée XXg
			Tolerances :	linéaires : JS 11 angulaires : +/- 5 arc min				
			* Cote finie hors tout		Numéro / Projet			
			Date	Nom	Herschel - SPIRE			
			Dessin	10-01-05	J.C. BLANC			
			Contrôle		Désignation			
			Approb.		Mecanisme FTS			
			Laboratoire d'Astrophysique de Marseille		Butée de Plaque Mobile			
C	14-09-05	J.C. BLANC			Numéro		SPI-MEC-10-DD-03-C	
B	21-04-05	J.C. BLANC					1/1	
Ind.	Modification	Date	Nom					