

ASTRIUM

Test Procedure

Herschel

Title: **H-PLM STM2 Straylight Test Procedure**
Note: This procedure contains hazardous operation

CI-No: 121 000

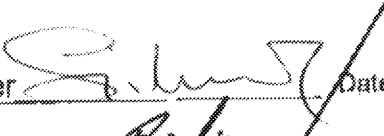
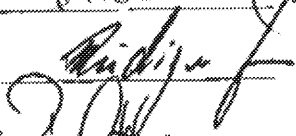
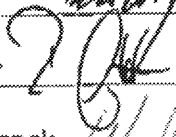
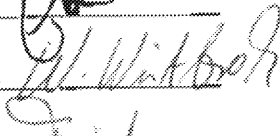
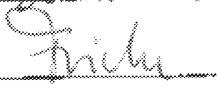
Prepared by:	S. Idler 	Date:	4.10.06
Checked by:	R. Hohn 		4.10.06
Product Assurance:	R. Stritter 		04.10.06
Configuration Control:	W. Wietbrock 		05.10.06
Project Management:	Dr. W. Fricke 		05/10/2006

Distribution: See Distribution List (last page)

Copying of this document, and giving it to others and the use or communication of the contents thereof, are forbidden without express authority. Offenders are liable to the payment of damages. All rights are reserved in the event of the grant of a patent or the registration of a utility model or design.

Issue	Date	Sheet	Description of Change	Release
1	06.10.2006	All	Initial issue	

Table of Content

1	Introduction	7
1.1	Scope of Document	7
1.2	Test Rational and Test Objective	7
2	Documents/Drawings	9
2.1	Applicable Documents	9
2.2	Reference Documents	9
3	Test Configuration	10
3.1	Principle Test Set-up	10
3.2	HPLM Configuration	12
3.3	GSE Configuration	14
3.3.1	MGSE	14
3.3.2	CVSE	14
3.3.3	EGSE	15
3.3.4	Laboratory Equipment	15
3.4	Facilities	15
4	Test Requirements	16
4.1	Environmental Conditions	16
4.2	Cryostat conditions	16
4.3	Precautions and Safety	17
4.4	Quality Assurance	17
4.5	Test Sequence	18
4.6	Test Success Criteria	19
5	Documentation	21
5.1	Documents required prior to the Test	21
5.2	Documents required during the Test	21
5.3	Documents required after the Test	21
6	Organisation and Responsibilities	22

7	Step-by-step Procedure	23
7.1	General remarks	23
7.2	Test Preparation	24
7.2.1	Perform SPIRE Bench Test	24
7.2.2	Mate SPIRE WU with SPIRE FPU	25
7.2.3	Install and Check Photoconductor Read-Out Equipment	26
7.2.4	Install and Check Hot Blackbody Source	27
7.2.5	Perform Cryostat Setup	28
7.2.6	Perform SPIRE SFT Cold	30
7.3	Straylight Measurement during Illumination through LO Windows	31
7.3.1	Perform SPIRE Cooler Recycle	31
7.3.2	Switch SPIRE to Operation Mode	32
7.3.3	Perform Straylight Measurements during Illumination through LO Windows	32
7.4	Straylight Measurement versus Cryocover Mirror Temperature	36
7.4.1	Perform Straylight Measurements versus Cryocover Mirror Temperature	36
7.4.2	Switch SPIRE to Stand-by Mode	37
7.4.3	Warm-Up Thermal Shields	38
7.5	Straylight Measurements versus Thermal Shield Temperature	39
7.5.1	Perform Cryostat Setup	39
7.5.2	Perform SPIRE Cooler Recycle	40
7.5.3	Switch SPIRE to Operation Mode	40
7.5.4	Perform Straylight Measurements versus Thermal Shield Temperature	41
7.5.5	Switch Off SPIRE	41
8	Summary Sheets	42
8.1	Procedure Variation Summary	42
8.2	Non Conformance Report (NCR) Summary	43
8.3	Sign-off Sheet	44

Table of Figures

Figure 3-1: Principle Test Set-up for Herschel STM2 Straylight Test _____ 10
Figure 3-2: He Flow Scheme during Straylight Test (HTT closed) _____ 11
Figure 3-3: PLM Configuration for Herschel STM2 Straylight Test (Dummy Panel with SPIRE Warm Units not indicated) _____ 13

List of Tables

Table 3-1: As-built Status of Instruments 13
Table 6-1: Test Responsibilities 22
Table 6-2: Test Personnel 22
Table 8-1: List of Procedure Variations..... 42
Table 8-2: List of NCR's..... 43

1 Introduction

1.1 Scope of Document

This document specifies the straylight test to be performed in the frame of the Herschel PLM STM2 programme. It defines the test configuration and provides the step-by-step procedure of the activities to be carried out. This comprises the cryostat operation as well as the SPIRE operation, both being linked.

The step-by-step procedure calls up SPIRE procedures for test steps related to the SPIRE operation.

1.2 Test Rational and Test Objective

In the frame of the HPLM EQM tests higher than predicted background radiation was measured by PACS and also by SPIRE (see HP-2-ASED-NC-1675).

Subsequent investigations revealed that several inconsistencies existed between the actual hardware as-built status and the as-built status assumed in the straylight mathematical model which was used for the EQM test predictions. The major differences which have been identified are:

- Actual SPIRE FPU CQM entrance baffle was metallic; the model assumed black coating as is the case for PFM.
- Actual cryocover mirror BRDF (Bidirectional Reflectance Distribution Function) was much higher than assumed in the model.

The accordingly corrected straylight mathematical model finally shows good compliance to the EQM test results (see RD 01 and RD 02). The observed excessive EQM straylight is considered understood.

In order to get further confidence ASED have been requested by ESA/AAS-F to perform a straylight test within the Herschel STM2 programme.

The following major straylight relevant hardware modifications have been implemented with respect to the EQM programme:

- SPIRE FPU EQM entrance baffle black coated in order to get more flight representative straylight conditions at this important area.
- Cryocover mirror polished in order to minimise the on-ground straylight within the instruments field of view.
- LOU baffle modified / extended in order to attenuate potential straylight through LO windows and the HIFI FPU.

The applicable instrument configuration is as follows:

- SPIRE CQM is the only active instrument (i. e. is the "straylight sensor"). SPIRE will be operated in photometry mode only (spectrometry mode is not available at CQM).

- HIFI FPU CQM is used as straylight dummy. It represents the band 3 straylight path from the LO windows through the FPU on the FPU M3 into the cryostat instruments compartment. The other six bands are optically blocked (taped) since not flight representative.
- PACS FPU MTD remains installed since the PACS CQM instrument is no more available.
- A photoconductor has been installed on one of the SPIRE LO thermal links. This photoconductor is not mathematically modelled. Its measurements will only be used for qualitative purposes and in case the SPIRE instrument fails.

The defined objective of the STM2 straylight test is to

- Measure the on-ground straylight seen by SPIRE CQM after the hardware modifications (which should now be similar to the expected on-ground straylight for SPIRE PFM).
- Assess straylight path through the LO windows and HIFI FPU on SPIRE after implementation/modification of LOU baffles.
- Correlate the straylight mathematical model with the test data, as far as possible.

For these objectives the following notes and limitations should be taken into account:

- Straylight requirements exist for in-flight operation only. However, it has to be ensured that on-ground straylight is low enough to allow proper functional testing of the instruments. This was the case for EQM.
- The correlation of the mathematical model with the test data is only possible in a very limited way (in particular in view of the extrapolation to operational conditions) since
 - The vast majority of the calculated straylight is coming from outside the cryostat (from the hexapod, etc.) and cannot be simulated at all during on-ground testing.
 - At EQM the high cryocover mirror BRDF was driving the PACS straylight but had only very little impact on the SPIRE straylight; since PACS is not available for this test a correlation of that aspect is very difficult.
 - The SPIRE straylight measurements can hardly distinguish between straylight reflected back from the cryocover mirror and straylight from elsewhere in the cryostat. The straylight reflected back from the cryocover mirror is practically no more present during in-flight operation.
- On EQM the impact of the straylight through the LO windows was mainly on PACS via the cryocover mirror (due to its high BRDF). Since PACS is not available for this test a correlation is difficult.

For the STM2 straylight test three test blocks have been defined:

Background radiation measurements by SPIRE

- During illumination through band 3 LO window and alignment windows with a high temperature blackbody source.
- At different cryocover mirror temperatures.
- At different thermal shield temperatures.

2 Documents/Drawings

2.1 Applicable Documents

The following documents are applicable to this procedure:

AD 01	HP-2-ASED-PL-0007	Herschel PA Plan	Issue 2.1
AD 02	HP-2-ASED-PL-0023	Herschel Contamination Control Plan	Issue 2
AD 03	HP-2-ASED-PR-0001	Documentation Identification Procedure and Documentation Management	Issue 3

2.2 Reference Documents

In this section all documents which are referenced and/or called up in this procedure are listed.

RD 01	HP-2-ASED-AN-0020	Explanation for Excessive EQM Straylight	Issue 2
RD 02	HP-2-ASED-TN-0139	Description of ASAP file H_iss4_2006_06.inr	Issue 2
RD 03	SPIRE-RAL-NOT-002028	Making SPIRE ESD Safe	Issue 2,
RD 04	HP-2-ASED-TP-0106	Herschel FM Cover Flushing Technical Operations Procedure	Issue 1
RD 05	TBD	SPIRE WU Bench Test	
RD 06	TBD	SPIRE Straylight Test Procedure	

3 Test Configuration

3.1 Principle Test Set-up

The principle HPLM STM2 test set-up is shown in Figure 3-1.

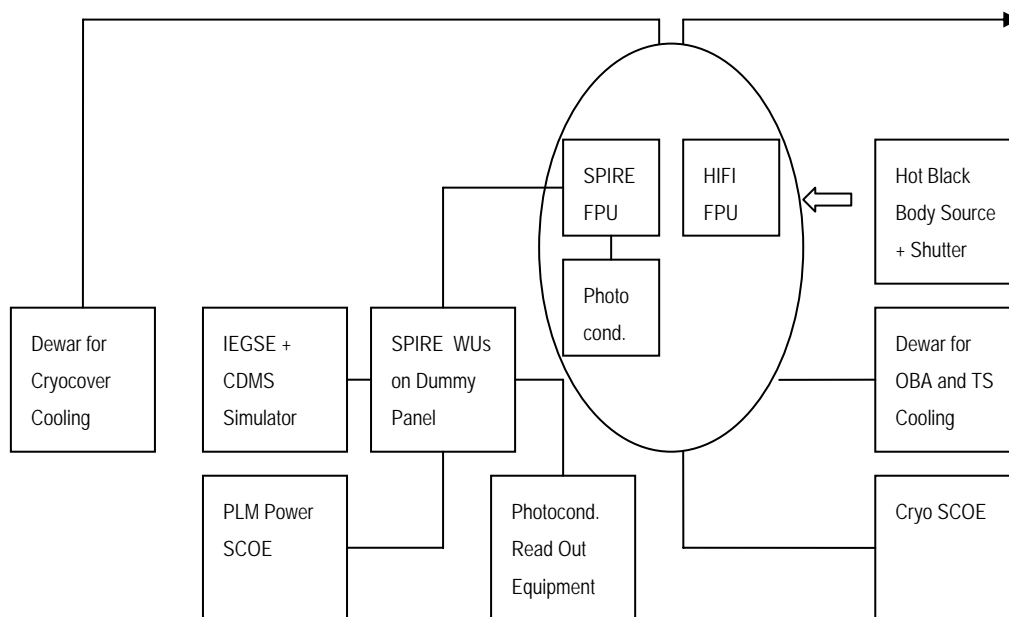

Figure 3-1: Principle Test Set-up for Herschel STM2 Straylight Test

The PLM is installed on the MTP. The SVM is not connected. Instead, appropriate adapters (TTAP/IAD) are mounted, one of them carrying the SVM connector brackets (see Figure 3-3). The cryostat is tilted to >23 deg in +y-direction in order to allow SPIRE cooler recycling.

The cryostat is controlled by the Cryo SCOE. During the straylight test the HTT is filled with He II to a level $>80\%$ and is closed (valves V102 and V104 closed). The HTT provides the L0 interfaces. In consequence of NCR HP-2-ASED NC-2590 the HOT is evacuated and also closed (valves V105, V701 and V702 closed). Instead, the He flow to cool the L1, L2 and L3 interfaces and thermal shields is provided by an external Dewar which is connected to the safety line. The He flow can be adjusted with valves at the Dewar.

Figure 3-2 shows the He flow scheme of the cryostat PFM applicable for this test.

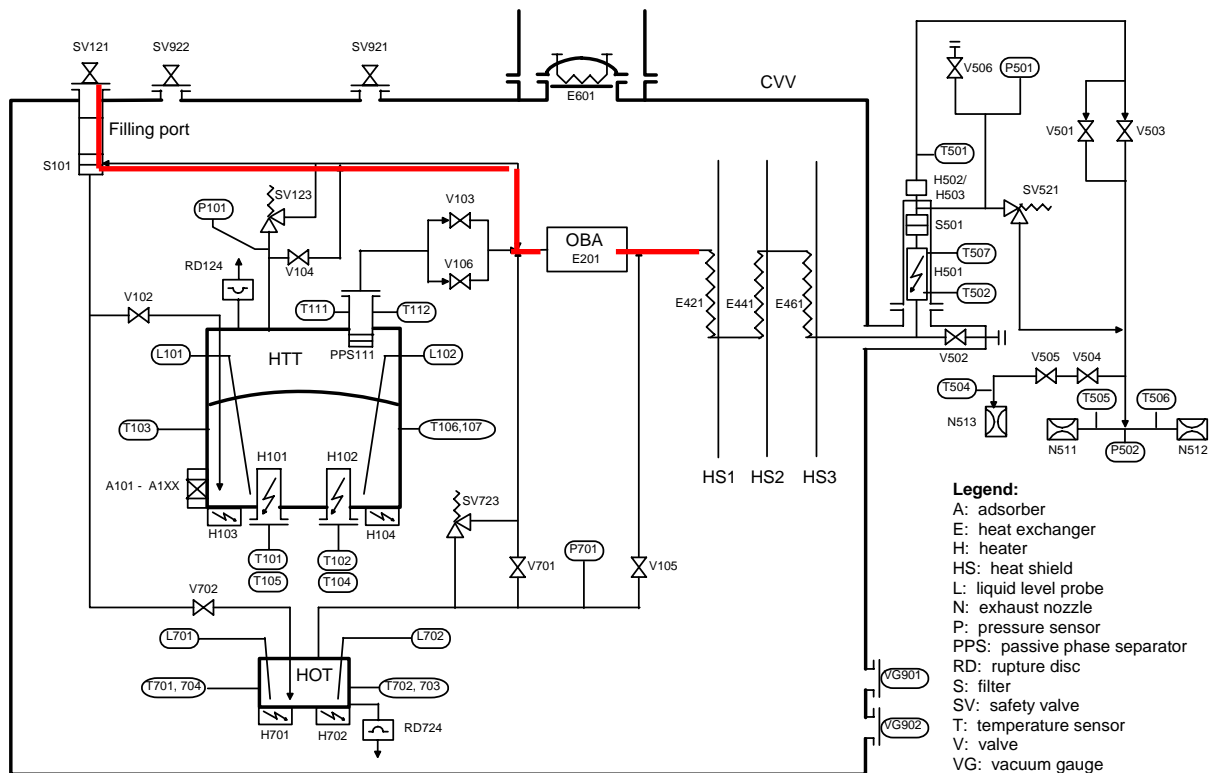

Figure 3-2: He Flow Scheme during Straylight Test (HTT closed)

The cryocover mirror is cooled by He flushing from an external Dewar. The cryocover mirror temperature is controlled by adjusting the He flow with valves at the Dewar and the transfer line.

The optical bench is equipped with the SPIRE FPU CQM being the only operated instrument, the HIFI FPU CQM used as not operated straylight dummy and the PACS FPU MTD.

The SPIRE WUs and WIH are mounted on a special dummy panel which is fixed to the adapter which carries the SVM connector brackets (TTAP). The electrical connection of the SPIRE WUs to the SPIRE FPU is accomplished using the SVM SIH EQM which is connected to the SVM connector brackets. From there up to the SPIRE FPU the CVV ext. and int. SIH PFM is used.

SPIRE is operated from the SPIRE IEGSE via the SPIRE CDMS simulator. For the straylight measurements SPIRE is switched in the photometry mode. The SPIRE operation is based on the existing and validated ILT test procedures.

SPIRE is powered by the PLM Power SCOE being operated in local mode.

No connection between the Cryo SCOE, PLM Power SCOE and the IEGSE is planned. The cryostat data are displayed on a monitor in real time and are recorded. The IEGSE is connected to an external network.

In addition a photoconductor is mounted on the SPIRE FPU LO strap and connected with existing SPIRE SIH lines. The photoconductor is supplied and monitored by specific read-out equipment which is connected to the warm end of the SPIRE SIH.

A blackbody source plus filter and chopper is positioned in front of the band 3 LO window and the alignment windows in order to allow specific straylight stimulation via the LO windows. The detailed blackbody source set-up still TBD. The chopper is operated off-line (no phasing with the instrument measurements).

3.2 HPLM Configuration

Figure 3-3 shows the HPLM configuration.

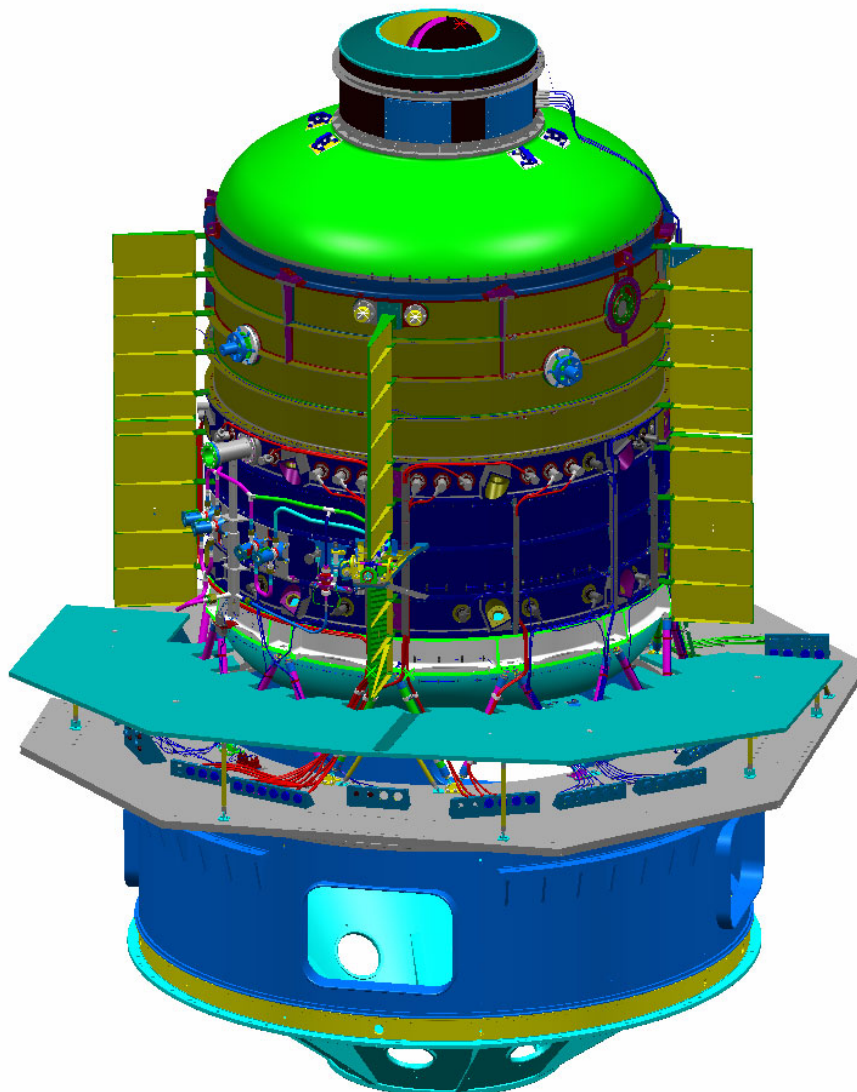

Figure 3-3: PLM Configuration for Herschel STM2 Straylight Test (Dummy Panel with SPIRE Warm Units not indicated)

The following major straylight related hardware modifications with respect to the cryostat STM have been implemented for STM2:

- OBA and instrument shield cut-outs closed/taped (as far as possible).
- Cryocover mirror polished.
- LOU TS1 baffle introduced.
- LOU TS2 baffle modified with vanes.
- HIFI FPU/instrument shield baffle labyrinth black anodised.

The as-built status of the instruments is shown in Table 3-1:

CI Number	Description	Built Status
153 100	HIFI instrument (FPU only)	Downgraded CQM
153 200	SPIRE Instrument	FPU CQM; DRCU QM2, DPU CFM2, WIH QM
142 513	PACS instrument (FPU only)	MTD

Table 3-1: As-built Status of Instruments

SPIRE consists of

- FPU (incl. JFETs) CQM with entrance baffle black coated.
- DRCU (DCU and FCU) QM2
- DPU CFM2
- WIH (as used for PLM EQM testing)

The HIFI FPU is wrapped in 1 mil Mylar foil to avoid particulate contamination of the cryostat (see NCR HP-2-ASED-NC-2330). Due to missing TMM for the HIFI FPU CQM and in order to have a clear thermal configuration the L0 and L1 thermal straps to the HIFI FPU have been disassembled, the corresponding HIFI FPU interfaces have been thermally short circuited to L2. The HIFI FPU is connected to the SIH (as far as the FPU provides connectors) for thermal reasons. The related SVM CB connectors are protected by ESD caps (no termination plugs). The HIFI FPU does not provide SMA interfaces for connecting the coaxial cables. In order to have a clear thermal configuration the coax cables have been disassembled.

PACS MTD remains as during the STM programme.

The following list summarises the major straylight related hardware modifications which have been implemented in the instrument CQMs for STM2:

- SPIRE FPU CQM entrance baffle black coated.
- HIFI FPU CQM packed in Mylar foil (see NCR HP-2-ASED-NC-2330)
- HIFI FPU CQM channel 3 optically open - other channels closed (taped with Mylar foil).
- HIFI FPU AD backside light tight taped.
- Photoconductor mounted on SPIRE FPU L0 strap and connected with existing SPIRE SIH lines

The detailed hardware and software as-built standard of the cryostat and instruments will be validated at the TRR and reported in the TRR minutes.

3.3 GSE Configuration

3.3.1 MGSE

Following MGSE is required

- MPT which carries the PLM (incl. dummy panel with SPIRE WUs) and which allows tilting of the PLM in y-direction.
- Mechanical support for the high temperature blackbody source. The mechanical support should allow moving the blackbody source in x-, y- and z-direction and tilting up to +/- 20 deg around PLM y-axis. Required accuracies: +/- 5 mm (lateral) and +/- 5 deg (rotation).
- Scaffolding which allows manual access to the temperature blackbody source.
- Thermal shield (e. g. reflective metal plate) to protect the LO windows.

3.3.2 CVSE

For the cryostat operation during the straylight test the following CVSE is required.

- Vent line connected to He S/S outlet V502 for HOT operation (HTT closed).
- He Dewar, valves and vent lines for cryocover mirror cooling.
- He Dewar, valves and vent lines for L1, L2, L3 interfaces and thermal shield cooling.
- Flow meters to measure the He flow from the Dewars.

This list does not contain the equipment needed for the cool down and He II production.

The relevant cryo operations are described in the related procedures (RD 04).

3.3.3 EGSE

The following EGSE is required:

- Cryo SCOE in PFM configuration.
- PLM Power SCOE (operated in local mode) plus cables to provide the 28 V (2 outlets) to SPIRE FCU and DPU (power interfaces on FCU and DPU as per IID-B).
- Read-out equipment (driver electronics plus oscilloscope; manual record required) plus harness for supply and monitoring of the photoconductor (all will be provided by RAL).
- IEGSE consisting of 3 computers connected via LAN for commanding, QLA and data base server plus software.
- CDMS simulator consisting of 1 computer to be connected to IEGSE via LAN plus software (will be provided by RAL).
- 1553 bus cable between CDMS simulator and DPU (standard cable, length pending on EMC test constraints) (will be provided by RAL).
- High temperature blackbody source Pegasus R Model 970 incl. heat filter and chopper (will be provided by RAL).
- Monitor which displays the real time readings of the cryostat temperatures to be positioned close to IEGSE monitors.

3.3.4 Laboratory Equipment

The following list defines the instruments and tools to be used for this test. All equipment shall be calibrated and shall be within the calibration period during the test time.

- None in addition to those listed in sections 3.3.1, 3.3.2 and 3.3.3

3.4 Facilities

The activities detailed in this procedure shall be carried out at ESTEC in Noordwijk. Clean room is Fj 008, class 100 000.

4 Test Requirements

4.1 Environmental Conditions

All activities specified in this procedure have to be performed in a clean room class 100000 federal standard 209 E.

Temperature: $22^{\circ}\text{C} \pm 3^{\circ}\text{C}$

Relative Humidity: 40% to 55%

The cleanliness requirements of FED 209E will be observed throughout the activities, and the overall contamination control requirements identified in the Herschel Contamination Control Plan (AD 2) will be observed.

4.2 Cryostat conditions

During SPIRE operation the cryostat parameters shall be adjusted such that the following conditions are achieved:

- SPIRE L0: $< 1.8 \text{ K}$
- SPIRE L1: $< 5 \text{ K}$
- OB: $< 12 \text{ K}$
- SPIRE L3: $< 15 \text{ K}$
- Instrument shield: $< 16 \text{ K}$
- Cryocover mirror: as per step-by-step procedure

During SPIRE cooler recycling the cryostat must be tilted in +y-direction with an angle of $> 23^{\circ}$.

The following cryostat parameters shall be recorded:

- All cryostat thermistor readings
- He flow through the OB and thermal shields
- He flow through cryocover mirror*)

*) Note that during SPIRE EQM IMT a high impact of cryocover mirror temperature on L1 has been observed.

4.3 Precautions and Safety

The following general safety rules have to be respected:

- The standard technical rules for mechanical and electrical integration and test activities are applicable.
- The hardware has to be handled by authorized personnel only.

The following specific safety rules have to be respected:

- In case of an unexpected large release of He it may be necessary to treat victims for suffocation and cold burns. If required, the victim shall be removed from the vicinity of the leak.
- In case of operation of the cryostat safety system the following immediate activities shall be performed:
 - operation of safety valve: everybody has to leave the test room, except test conductor and necessary CVSE operations personnel.
 - operation of burst disc: everybody has to leave the test room.
 - facility emergency services shall be immediately contacted explaining nature and location of accident.
- In case of operation of hot blackbody source in front of the LO windows the following precautions have to be taken:
 - The minimum distance between hot blackbody source and LO windows shall be TBD cm.
 - The LO windows shall be protected by a shield (metal plate) except when illumination is explicitly required in the step-by-step procedure.

In order to prevent ESD sensitive H/W from any possible damages by accidental electrostatic discharges an ESD protected area must be defined and setup during ESD sensitive activities (harness connection).

In addition the following instrument specific ESD requirements as defined in RD 03 are applicable.

4.4 Quality Assurance

Quality Assurance shall monitor all operations (handling, transportation, disassembly, installation and test) as necessary to assure compliance with this procedure and the applicable requirements of the Herschel PA Plan (AD 1).

In the course of this procedure PA shall pay particular attention to:

- the application of safety rules
- the records in the log-sheet
- the recording of the serial number of the test equipment used

- ensure that the test equipment used is within actual calibration cycle

PA has to make sure that NCR's are raised when applicable and treated by NRB procedure as defined in the Herschel PA Plan (AD 1).

After the conclusion that an activity is successfully completed, this activity has to be signed by the responsible AIT and PA engineer in the step-by-step procedure. Also relevant log sheets have to be filled out and signed.

Before start of the test activities a Test Readiness Review (TRR) shall be held. A Post Test Review (PTR) shall finally conclude on the test.

4.5 Test Sequence

The principle test flow is given below.

Test Preparation (at any time prior to the straylight test)

- Check and connect 28 V power to SPIRE WUs.
- Connect IEGSE with CDMS simulator to SPIRE WUs.
- Perform SPIRE WUs bench test in conjunction with IEGSE (1 hour).

Test Day 1 (Test Preparation)

- Connect SPIRE WUs to SPIRE FPU.
- Install and check photoconductor read-out equipment.
- Install mechanical support for blackbody source incl. filter and shutter and pre-position and check it.
- Check HTT filling level and temperature to ensure the required L0 temperature for SPIRE operation throughout the straylight test.
- Check OB and thermal shield cooling equipment (filling level of external Dewar, etc.). Adjust initial He flow such that the required L1, OB, L3 and instrument shield temperatures for SPIRE operation are achieved and stable.
- Install and check cryocover mirror cooling loop (temperature shall be adjustable between 20 K and 200 K). Adjust initial He flow such that mirror temperature is at 20 K and stable.
- Perform SPIRE SFT cold.

Test Day 2

1. Perform SPIRE cooler recycle. During cooler recycle the cryostat shall be tilted by >23 deg to +y-direction.
2. Switch SPIRE in operation mode.

3. Illuminate with blackbody source band 3 LO window from different angles and positions.
4. Observe and record SPIRE measurements and the photoconductor read-outs.
5. Illuminate with blackbody source the alignment windows from different angles and positions.
6. Observe and record SPIRE measurements.
7. Change cryocover mirror temperature (increase to 200 K and decrease back to 20 K)
8. Observe and record SPIRE measurements and the photoconductor read-outs during cryocover mirror temperature variation.
9. Throttle He flow through OB and thermal shields to get higher thermal shield temperature to prepare for the next days test.

Note: Throttling of He flow causes also higher L1 temperature which will lead to SPIRE cooler exhaust.

Test Day 3

1. Increase He flow through OB and thermal shields to achieve the required L1, OB and L3 temperatures to be able to operate SPIRE. In parallel the thermal shields will cool down as well but with a much lower time constant.
2. If L1 is < 5K then perform SPIRE cooler recycle. During cooler recycle the cryostat shall be tilted by >23 deg to +y-direction.
3. Switch SPIRE in operational mode.
4. Observe and record SPIRE measurements and the photoconductor read-outs during the cool down of the thermal shields throughout the day.
5. Switch off SPIRE.
6. End of straylight test.

The above test flow is to be considered as a guideline.

4.6 Test Success Criteria

The straylight test is considered successful when the SPIRE instrument has performed reasonable measurements

- during illumination through band 3 LO window and alignment windows with high temperature blackbody source,
- at different cryocover mirror temperatures and
- at different thermal shield temperatures

as specified in this procedure.

A final conclusion of the test can be given not before the completion of the post processing of the SPIRE measurements and comparing the results with the test predictions. During the test just rough assessments are possible.

5 Documentation

5.1 Documents required prior to the Test

- Test prediction.
- Assessment on heat load on LO windows during illumination by hot blackbody source.
- This test procedure signed and approved.
- TRR minutes.

5.2 Documents required during the Test

- This test procedure signed and approved.

5.3 Documents required after the Test

- Filled out test procedure (as-run procedure).
- Records of cryostat temperature curves (raw data measured during straylight test).
- PTR minutes.
- Evaluation report of SPIRE measurements within 3 weeks after completion of the test.
- Test evaluation report (incl. test summary and conclusion) to be released within 3 weeks after availability of SPIRE straylight measurement results.

6 Organisation and Responsibilities

The responsibilities for the straylight test are defined as follows:

Task	Company
Test management	ASED
Test specification/procedure	ASED, supported by Instruments
Test setup/instrumentation	ASED, supported by Instruments
Test execution	ASED, supported by Instruments
SPIRE operation	RAL
Test facility	ESA
Test report/evaluation	ASED, supported by Instruments

Table 6-1: Test Responsibilities

The following manpower is required to perform the activities described in this procedure:

Title	Function	Name*)
Test Manager	Manages all test activities.	
Cryo Operator	Operates the cryostat during testing and adjusts the required temperatures.	
EGSE Operator	Operates the PLM EGSE (Power SCOE)	
Mech. Engineer	Performs all mech. integration activities, handles the PLM during testing (e.g. tilting of PLM), installs hot blackbody source.	
El. Engineer	Performs all el. integration activities	
SPIRE Engineer	Operates SPIRE via IEGSE and evaluates instrument data; monitors and records photoconductor data.	
PA Representative	Ensures that PA requirements are met.	
Customer	Supervises all activities	

*) Names to be registered prior to start of test activities

Table 6-2: Test Personnel

7 Step-by-step Procedure

7.1 General remarks

This step-by-step procedure calls up the following lower level procedures:

- RD 03
- RD 04
- RD 05
- RD 06

The filled out lower level as-run-procedures being part of the test report shall refer to the corresponding test step number of this procedure.

All test steps related to SPIRE commanding are executed by RAL.

Location:	PA: Name	Date:	Operator:		
			Date:		

7.2 Test Preparation

7.2.1 Perform SPIRE Bench Test

These test steps are executed by RAL.

Step-No.	Test-Step-Description	Nominal Value	Actual Value	Comments	P	N
1	Check that ESD precautions are implemented. ESD precautions shall be taken especially when open connectors are present.					
2	Switch on 28 V power for SPIRE DPU (with harness not yet connected to SPIRE).					
3	Check voltage between <ul style="list-style-type: none"> • Pin 2 (sig) to pin 4 (ret) • Pin 7 (sig) to pin 9 (ret) 	26V < x < 29V 26V < x < 29V		Use break-out-box.		
4	Switch off 28 V power for SPIRE DPU.	0 V				
5	Switch on 28 V power for SPIRE FCU (with harness not yet connected to SPIRE).					
6	Check voltage between <ul style="list-style-type: none"> • Pin 2 (sig) to pin 4 (ret) • Pin 7 (sig) to pin 8 (ret) 	26V < x < 29V 26V < x < 29V		Use break-out-box.		
7	Switch off 28 V power for FCU.	0 V				

Location:	PA: Name	Date:	Operator:		
			Date:		

Step-No.	Test-Step-Description	Nominal Value	Actual Value	Comments	P	N
8	Connect 28 V power for SPIRE DPU to SPIRE DPU connector J01.					
9	Connect 28 V power for SPIRE FCU to SPIRE FCU connector J05.					
10	Connect IEGSE with CDMS simulator to SPIRE DPU.					
11	Switch on 28 V power for SPIRE DPU.	26V < x < 29V				
12	Switch on 28 V power for SPIRE FCU.	26V < x < 29V				
13	Execute SPIRE WUs bench test as per procedure RD 05.					
14	Switch off 28 V power.	0 V				

7.2.2 Mate SPIRE WU with SPIRE FPU

Step-No.	Test-Step-Description	Nominal Value	Actual Value	Comments	P	N
1	Check that ESD precautions are implemented. ESD precautions shall be taken especially when open connectors are present.					
2	Remove termination plug TBD from SVM connector TBD.					
3	Connect SVM SIH plug TBD to SVM connector TBD.					

Location:	PA: Name	Date:	Operator:		
			Date:		

Step-No.	Test-Step-Description	Nominal Value	Actual Value	Comments	P	N
4	Repeat step 2 and 3 for SVM SIH/SVM connector plug pairs TBD/TBD, TBD/TBD, ...					
5	Perform visual inspection of the mating (correct fitting, correct allocation)					

7.2.3 Install and Check Photoconductor Read-Out Equipment

These test steps are executed by RAL.

Step-No.	Test-Step-Description	Nominal Value	Actual Value	Comments	P	N
1	Check that ESD precautions are implemented. ESD precautions shall be taken especially when open connectors are present.					
2	Connect SVM SIH plug TBD to photoconductor read-out equipment connector TBD.					
3	Connect oscilloscope to photoconductor read-out equipment connector TBD.					
4	Switch on read-out equipment and oscilloscope.					
5	Check output signal on oscilloscope.	TBD				
6	Switch off read-out equipment and oscilloscope.					

Location:	PA: Name	Date:	Operator:		
			Date:		

7.2.4 Install and Check Hot Blackbody Source

Caution: The following specific rules have to be regarded when the hot blackbody source is operated in front of the LO windows:

- The minimum distance between hot blackbody source and LO windows shall be TBD cm.
- The LO windows shall be protected by a shield (metal plate) except when illumination is explicitly required in the step-by-step procedure.

Step-No.	Test-Step-Description	Nominal Value	Actual Value	Comments	P	N
1	Install hot blackbody source incl. filter and shutter on the mechanical support such that it is about 30 cm in front of band 3 LO window.					
2	Check that the hot blackbody source can be moved in x- and z-direction by +/- 5 cm and in y- direction by +/- 20 cm and can be tilted up to +/- 20 deg around PLM y-axis.					
3	Check that the hot blackbody source can be moved in front to the alignment windows.					
4	Position hot blackbody source such that it does not illuminate the cryostat.					
5	Switch on hot blackbody source and shutter and check whether it correctly operates.					
6	Switch off hot blackbody source and shutter.					

Location:	PA: Name	Date:	Operator:		
			Date:		

7.2.5 Perform Cryostat Setup

Step-No.	Test-Step-Description	Nominal Value	Actual Value	Comments	P	N
1	Check HTT temperature	<1.7 K		HTT temperature shall be such that SPIRE L0 temperature remains below 1.8 K throughout the straylight test.		
2	Check HTT filling level	>80 %				
3	Tilt cryostat to +y-direction.	>23deg				
4	Adjust He flow such that the following temperatures are achieved: <ul style="list-style-type: none"> • SPIRE L1 • OB • SPIRE L3 • Instrument shield • TS1 • TS2 • TS3 	<5 K <12 K <15 K <16 K < 50 K < 65 K < 130 K				

Location:	PA: Name	Date:	Operator:		
			Date:		

Step-No.	Test-Step-Description	Nominal Value	Actual Value	Comments	P	N
5	Install and check cryocover mirror cooling loop (temperature shall be adjustable between 20 K and 200 K). Adjust initial He flow such that cryocover mirror temperature is at following procedure RD 04.	20 K +/- 10 K				

Location:	PA: Name	Date:	Operator:		
			Date:		

7.2.6 Perform SPIRE SFT Cold

These test steps are executed by RAL.

Step-No.	Test-Step-Description	Nominal Value	Actual Value	Comments	P	N
1	Switch on 28 V power.	26V < x < 29V				
2	Execute SPIRE SFT cold as per procedure RD 06.					

Location:	PA: Name	Date:	Operator:		
			Date:		

7.3 Straylight Measurement during Illumination through LO Windows

7.3.1 Perform SPIRE Cooler Recycle

These test steps are executed by RAL.

Step-No.	Test-Step-Description	Nominal Value	Actual Value	Comments	P	N
1	Check cryostat temperatures to be suitable for SPIRE operation: <ul style="list-style-type: none"> • SPIRE L1 • OB • SPIRE L3 • Instrument shield • TS1 • TS2 • TS3 • Cryocover mirror 	<5 K <12 K <15 K <16 K < 50 K < 65 K < 130 K 20 K +/- 10 K				
2	Execute SPIRE cooler recycle as per procedure RD 06.					

Location:	PA: Name	Date:	Operator:		
			Date:		

7.3.2 Switch SPIRE to Operation Mode

These test steps are executed by RAL.

Step-No.	Test-Step-Description	Nominal Value	Actual Value	Comments	P	N
1	Switch SPIRE to operation mode as per procedure RD 06.					

7.3.3 Perform Straylight Measurements during Illumination through LO Windows

Caution: The following specific rules have to be regarded when the hot blackbody source is operated in front of the LO windows:

- The minimum distance between hot blackbody source and LO windows shall be TBD cm.
- The LO windows shall be protected by a shield (metal plate) except when illumination is explicitly required in the step-by-step procedure.

Step-No.	Test-Step-Description	Nominal Value	Actual Value	Comments	P	N
1	Position hot blackbody source incl. filter and shutter in front of band 3 LO window with a distance of	30 cm +/- 5cm				
2	Install heat shield between windows and hot blackbody source.					

Location:	PA: Name	Date:	Operator:		
			Date:		

Step-No.	Test-Step-Description	Nominal Value	Actual Value	Comments	P	N
3	Switch on hot blackbody source to and wait until temperature is stabilised (approx. 1 h).	~1200 °C				
4	Switch on shutter.					
5	Put SPIRE in data acquisition mode as per procedure RD 06 (section TBD).					
6	Remove heat shield.					
7	Observe SPIRE data and if found necessary move hot blackbody source towards the window and illuminate window from different angles (+/- 20 deg around PLM y-axis). Respect minimum distance to LO windows. Record blackbody source positions.					
8	Re-install heat shield between windows and hot blackbody source.					
9	Switch off shutter.					
10	Stop SPIRE data acquisition.					
11	Position hot blackbody source in front of the left alignment window with a distance of	30 cm +/- 5cm				
12	Switch on shutter.					
13	Put SPIRE in data acquisition mode as per procedure RD 06 (section TBD).					
14	Remove heat shield.					

Location:	PA: Name	Date:	Operator:		
			Date:		

Step-No.	Test-Step-Description	Nominal Value	Actual Value	Comments	P	N
15	Observe SPIRE data and if found necessary move hot blackbody source towards the window and illuminate window from different angles (+/- 20 deg around PLM y-axis). Respect minimum distance to LO windows. Record blackbody source positions.					
16	Re-install heat shield between windows and hot blackbody source.					
17	Switch off shutter.					
18	Stop SPIRE data acquisition.					
19	Position hot blackbody source in front of the right alignment window with a distance of	30 cm +/- 5cm				
20	Switch on shutter.					
21	Put SPIRE in data acquisition mode as per procedure RD 06 (section TBD).					
22	Remove heat shield.					
23	Observe SPIRE data and if found necessary move hot blackbody source towards the window and illuminate window from different angles (+/- 20 deg around PLM y-axis). Respect minimum distance to LO windows. Record blackbody source positions.					
24	Re-install heat shield between windows and hot blackbody source.					
25	Switch off shutter.					
26	Stop SPIRE data acquisition.					

Location:	PA: Name	Date:	Operator:		
			Date:		

Step-No.	Test-Step-Description	Nominal Value	Actual Value	Comments	P	N
27	Switch off hot blackbody source.					

Location:	PA: Name	Date:	Operator:		
			Date:		

7.4 Straylight Measurement versus Cryocover Mirror Temperature

7.4.1 Perform Straylight Measurements versus Cryocover Mirror Temperature

SPIRE is assumed to be still in operation mode.

The test steps related to SPIRE commanding are executed by RAL.

Step-No.	Test-Step-Description	Nominal Value	Actual Value	Comments	P	N
1	Check cryostat temperatures still to be suitable for SPIRE operation: <ul style="list-style-type: none"> • SPIRE L1 • OB • SPIRE L3 • Instrument shield • TS1 • TS2 • TS3 • Cryocover mirror 	<5 K <12 K <15 K <16 K < 50 K < 65 K < 130 K 20 K +/- 10 K				
2	Put SPIRE in data acquisition mode as per procedure RD 06 (section TBD).					

Location:	PA: Name	Date:	Operator:		
			Date:		

Step-No.	Test-Step-Description	Nominal Value	Actual Value	Comments	P	N
3	Increase cryocover mirror temperature to as per procedure RD 04. Stabilise the mirror temperature at certain stages within the warm-up to allow more precise measurements, as required (to be decided on-line).	200 K +/- 10K				
4	Observe SPIRE data during cryocover mirror temperature change					
5	Decrease cryocover mirror temperature to as per procedure RD 04.	20 K +/- 10 K				
6	Observe SPIRE data during cryocover mirror temperature change					
7	Stop SPIRE data acquisition.					

7.4.2 Switch SPIRE to Stand-by Mode

These test steps will be executed by RAL.

Step-No.	Test-Step-Description	Nominal Value	Actual Value	Comments	P	N
1	Switch SPIRE to stand-by mode as per procedure RD 06.					

Location:	PA: Name	Date:	Operator:		
			Date:		

7.4.3 Warm-Up Thermal Shields

Step-No.	Test-Step-Description	Nominal Value	Actual Value	Comments	P	N
1	Throttle He flow through OB and thermal shields to	~30 mg/sec		The He flow shall be adjusted such that at the morning of the next test day the temperature of TS2 is increased to about 100 K.		

Location:	PA: Name	Date:	Operator:		
			Date:		

7.5 Straylight Measurements versus Thermal Shield Temperature

7.5.1 Perform Cryostat Setup

Step-No.	Test-Step-Description	Nominal Value	Actual Value	Comments	P	N
1	Increase He flow through OB and thermal shields to	~200 mg/sec		The He flow shall be increased to a high value to achieve SPIRE operation temperatures as fast as possible.		
2	When SPIRE L1 is <5 K, OB temp is <12 K and L3 is <15 K, then throttle He flow through OB and thermal shields to	~100 mg/sec		The He flow shall be adjusted to the approximately the same value as at the start of the test (test step 7.3.1.1).		

Location:	PA: Name	Date:	Operator:		
			Date:		

7.5.2 Perform SPIRE Cooler Recycle

These test steps will be executed by RAL.

Step-No.	Test-Step-Description	Nominal Value	Actual Value	Comments	P	N
1	Check cryostat temperatures to be suitable for SPIRE operation: <ul style="list-style-type: none"> • SPIRE L1 • OB • SPIRE L3 • Cryocover mirror 	< 5 K < 12 K < 15 K 20 K +/- 10 K		The instrument shield and thermal shield temperatures are intentionally higher than at nominal conditions.		
2	Execute SPIRE cooler recycle as per procedure RD 06.					

7.5.3 Switch SPIRE to Operation Mode

These test steps will be executed by RAL.

Step-No.	Test-Step-Description	Nominal Value	Actual Value	Comments	P	N
1	Switch SPIRE to operation mode as per procedure RD 06.					

Location:	PA: Name	Date:	Operator:		
			Date:		

7.5.4 Perform Straylight Measurements versus Thermal Shield Temperature

These test steps will be executed by RAL.

Step-No.	Test-Step-Description	Nominal Value	Actual Value	Comments	P	N
1	Put SPIRE in data acquisition mode as per procedure RD 06 (section TBD).					
2	Observe/record SPIRE data during thermal shield temperature decrease.					
3	Stop SPIRE data acquisition.					

7.5.5 Switch Off SPIRE

These test steps will be executed by RAL.

Step-No.	Test-Step-Description	Nominal Value	Actual Value	Comments	P	N
1	Switch off SPIRE as per procedure RD 06.					

Location:	PA: Name	Date:	Operator:		
			Date:		

8 Summary Sheets

8.1 Procedure Variation Summary

The table below lists all activities which have been executed in the frame of this procedure but which deviate from the defined step-by-step procedure.

No.	Title	Date	Status	PA sign

Table 8-1: List of Procedure Variations

8.2 Non Conformance Report (NCR) Summary

This table lists all non-conformances generated during this test:

NCR - No.	NCR - Title	Date	Status	PA sign

Table 8-2: List of NCR's

8.3 Sign-off Sheet

	Date	Signature
Test Manager		
Cryo Operator		
EGSE Operator		
Mech. Engineer		
El. Engineer		
PA Responsible		

END OF DOCUMENT

	Name	Dep./Comp.		Name	Dep./Comp.
	Alberti von Mathias Dr.	ASG22		Steininger Eric	AED32
	Barlage Bernhard	AED13	x	Stritter Rene	AED11
x	Bayer Thomas	ASA42		Suess Rudi	OTN/ASA44
	Brune Holger	ASA45		Thörmer Klaus-Horst Dr.	OTN/AED65
	Edelhoff Dirk	AED2		Wagner Klaus	ASG22
	Fehringer Alexander	ASG13	x	Wietbrock Walter	AET12
	Fricke Wolfgang Dr.	AED 65		Wöhler Hans	ASG22
	Geiger Hermann	ASA42		Wössner Ulrich	ASE252
	Grasl Andreas	OTN/ASA44			
	Grasshoff Brigitte	AET12			
	Hartmann Hans	AED32	x	Alcatel Alenia Space Cannes	ASP
	Hauser Armin	ASG22	x	ESA/ESTEC	ESA
	Hendry David	Terma			
	Hengstler Reinhold	ASA42		Instruments:	
	Hinger Jürgen	ASG22	x	MPE (PACS)	MPE
x	Hohn Rüdiger	AED65	x	RAL (SPIRE)	RAL
x	Hölzle Edgar Dr.	AED32	x	SRON (HIFI)	SRON
	Huber Johann	ASA42		Subcontractors:	
	Hund Walter	ASE252		Air Liquide, Space Department	AIR
x	Idler Siegmund	AED312		Air Liquide, Space Department	AIRS
	Ivány von András	FAE12		Air Liquide, Orbital System	AIRT
	Jahn Gerd Dr.	ASG22		Alcatel Alenia Space Antwerp	ABSP
	Kalde Clemens	ASM2		Austrian Aerospace	AAE
	Kameter Rudolf	OTN/ASA42		Austrian Aerospace	AAEM
	Kettner Bernhard	AET42		APCO Technologies S. A.	APCO
	Knoblauch August	AET32		Bieri Engineering B. V.	BIER
	Koelle Markus	ASA43		BOC Edwards	BOCE
x	Koppe Axel	AED312		Dutch Space Solar Arrays	DSSA
x	Kroeker Jürgen	AED65		EADS Astrium Sub-Subsyst. & Equipment	ASSE
	La Gioia Valentina	Terma		EADS CASA Espacio	CASA
	Lamprecht Ernst	OTN/ASQ22		EADS CASA Espacio	ECAS
	Lang Jürgen	ASE252		EADS Space Transportation	ASIP
	Langenstein Rolf	AED15		Eurocopter	ECD
x	Langfermann Michael	ASA41		European Test Services	ETS
	Mattia Stefano	Terma		HTS AG Zürich	HTSZ
	Much Christoph	ASA43		Linde	LIND
	Müller Jörg	ASA42		Patria New Technologies Oy	PANT
	Müller Martin	ASA43		Phoenix, Volkmarshen	PHOE
	Peltz Heinz-Willi	ASG13		Prototech AS	PROT
	Pietroboni Karin	AED65		QMC Instruments Ltd.	QMC
	Platzer Wilhelm	AED2		Rembe, Brilon	REMB
	Reichle Konrad	ASA42		Rosemount Aerospace GmbH	ROSE
	Runge Axel	OTN/ASA44		RYMSA, Radiación y Microondas S.A.	RYM
x	Schink Dietmar	AED32		SENER Ingenieria SA	SEN
x	Schlosser Christian	OTN/ASA44		Stöhr, Königsbrunn	STOE
	Schmidt Rudolf	FAE12		Terma A/S, Herlev	TER
	Schweickert Gunn	ASG22		Terma A/S, Herlev	TERM