

SPIRE-AST-NOT-002370

Title: **Thermal Environment for Instrument Testing on Ground**

CI-No:

Prepared by: A. Hauser *A. Hauser* Date: 01.02.05  
Checked by: R. Kroeker *J. Kroeker* 3.2.2005  
Product Assurance: *for* R. Stritter *B. Balage* 9.2.05  
Configuration Control: R. W. Wietbrock *[Signature]* 09.02.05  
Project Management: W. Ruhe *W. Ruhe* 9.02.05

Distribution: See Distribution List (last page)

Copying of this document, and giving it to others and the use or communication of the contents thereof, are forbidden without express authority. Offenders are liable to the payment of damages. All rights are reserved in the event of the grant of a patent or the registration of a utility model or design.

Issue	Date	Sheet	Description of Change	Release
1	01.02.05	all	First formal issue	

## Table of Content

<b>1</b>	<b>Scope</b>	<b>5</b>
<b>2</b>	<b>Documents and Abbreviations</b>	<b>6</b>
2.1	Applicable Documents	6
2.2	Reference Documents	6
2.3	Abbreviations	6
<b>3</b>	<b>PLM EQM Testing</b>	<b>7</b>
3.1	EQM Objectives and Configuration	7
3.2	Expected Instrument Steady State I/F Temperatures	9
<b>4</b>	<b>PFM Thermal Testing with CVV at 293 K</b>	<b>10</b>
4.1	PFM Objectives and Configuration	10
4.2	Expected Steady State I/F Temperatures	10
4.2.1	Important Notes and Assumptions	10
4.2.2	PACS Interface Temperatures	10
4.2.3	SPIRE Interface Temperatures	12
4.2.4	HIFI Interface Temperatures	15
4.3	Transient Instrument Testing	16
<b>5</b>	<b>PFM TV Testing with CVV in LSS</b>	<b>21</b>
5.1	PFM Objectives and Configuration	21
5.2	Expected Interface Temperatures	21
<b>6</b>	<b>Thermal Environment during PFM Vibration Testing</b>	<b>22</b>
6.1	Vibration Test Configuration	22
6.2	Expected Instrument Temperatures during Vibration Test	22
<b>7</b>	<b>Conclusions</b>	<b>26</b>

## Table of Figures

Figure 3.1-1:	EQM Cryostat Configuration .....	8
Figure 4.2-1:	Reduced PACS Instrument TMM .....	11
Figure 4.2-2:	Reduced SPIRE Instrument TMM .....	12
Figure 4.2-3:	CVV Heat Flow Chart for IMT (Spire Spectrometer Mode).....	14
Figure 4.2-4:	OBA Heat Flow Chart for IMT (SPIRE Spectrometer Mode) .....	14
Figure 4.2-5:	Reduced HIFI Instrument TMM .....	15
Figure 4.3-1:	PACS L0 Interface Temperatures during IMT (based on orbit timeline)	17
Figure 4.3-2:	SPIRE L0 Interface Temperatures during IMT (based on orbit timeline)	17
Figure 4.3-3:	HIFI L0 Interface Temperatures during IMT (based on orbit timeline)	18
Figure 4.3-4:	PACS L1 Interface Temperatures during IMT (based on orbit timeline)	18
Figure 4.3-5:	SPIRE L1 Interface Temperatures during IMT (based on orbit timeline)	19
Figure 4.3-6:	HIFI L1 Interface Temperature during IMT (based on orbit timeline)	19
Figure 4.3-7:	HIFI L2 and OBP Temperature during IMT (based on orbit timeline)	20
Figure 4.3-8:	SPIRE L3 Temperatures during IMT (based on orbit timeline) .....	20
Figure 6.2-1:	Instrument Temperatures during PLM Vibration Test .....	22

## List of Tables

Table 3.2-1:	Expected I/F Temperatures for EQM Testing in the Modified ISO Cryostat	9
Table 4.2-1:	PACS Thermal Interface Temperatures for On-Ground Instrument Testing	11
Table 4.2-2:	SPIRE Thermal Interface Temperatures for On-Ground Testing.....	13
Table 4.2-3:	HIFI Thermal Interface Temperatures for On-Ground Testing.....	16
Table 6.2-1:	Predicted PACS Temperatures during Vibration Test.....	23
Table 6.2-2:	Predicted SPIRE Temperatures during Vibration Test.....	24
Table 6.2-3:	Predicted HIFI Temperatures during Vibration Test.....	25

## 1 Scope

The scope of this technical note is to compile all thermal analyses performed for instrument testing on ground and thus to close AI 04 of HP-2-ASP-MN-5308. In particular, the achievable thermal environment for instrument testing outside the TV chamber, i.e. with the Cryostat Vacuum Vessel (CVV) at 293 K is described. Hence, this TN also closes the CDR Board AI 1. Furthermore, predicted instrument temperatures during Herschel EPLM vibration testing are included in order to allow the instruments to assess the thermal/mechanical loads on their instruments.

## 2 Documents and Abbreviations

### 2.1 Applicable Documents

- AD 01 HERSCHEL/PLANCK Instrument Interface Document IID Part A, Doc.No.: SCI-PT-IIDA-04624, Issue 3.1, 12.02.2004
- AD 02 HERSCHEL/PLANCK Instrument Interface Document IID Part B for PACS, Doc.No.: SCI-PT-IIDB/PACS-02126, Issue 3.2, dated 02.03.2004
- AD 03 HERSCHEL/PLANCK Instrument Interface Document IID Part B for SPIRE, Doc.No.: SCI-PT-IIDB/SPIRE-02124, Issue 3.11, dated 07.01.2004
- AD 04 HERSCHEL/PLANCK Instrument Interface Document IID Part B for HIFI, Doc.No.: SCI-PT-IIDB/HIFI-02125, Issue 3.1, 31.01.2004

### 2.2 Reference Documents

- RD 01 H-EPLM Thermal Model and Analysis, Doc.No.: HP-2-ASED-RP-0011, Issue 4, dated 15.04.04
- RD 02 Instrument Testing on PLM EQM Level, Doc.No.: HP-2-ASED-PL-0021, Issue 3, dated 20.07.2004
- RD 03 Instrument Testing on PLM PFM and Satellite Level, Doc.No.: HP-2-ASED-PL-0031, Issue 2, dated 03.09.2004
- RD 04 Herschel PLM EQM AIT Plan, Doc.No.: HP-2-ASED-PL-0022, Issue 2.2, dated 30.08.2004
- RD 05 Satellite AIT Plan, Part 2: EPLM & S/C-PFM Acceptance Phase, Doc.No.: HP-2-ASED-PL-0026, Issue 2.1, dated 10.09.2004
- RD 06 List of Acronyms, HP-1-ASPI-LI-0077, Issue 2, dated 12.07.2004

### 2.3 Abbreviations

Abbreviations are listed in RD 06.

### 3 PLM EQM Testing

#### 3.1 EQM Objectives and Configuration

The main objective of the EQM test program on PLM EQM level is to check the mechanical, electrical, electromagnetic and thermal compatibility of the instruments with the PLM and the PLM environment. Another important objective is to validate the instrument integration, alignment and test procedures and the PLM test set-up as far as possible and to gain experience in operating the PLM and GSE for the PFM programme.

The EQM AIT programme uses the ISO QM cryostat which has been refurbished and modified in some areas to provide as much as possible the Herschel cryostat environmental conditions. The PLM hardware comprises the refurbished and modified ISO cryostat QM plus a newly developed SVM simulator.

The ISO cryostat is identical to the Herschel cryostat PFM as regards the

- optical bench with its mechanical and thermal interfaces to the FPUs
- instrument shield with LO beam baffles
- cryogenic harness with its electrical interfaces to the FPUs, LOU and Warm Units
- LOU support structure with its mechanical interfaces to the LOU

The cryostat provides an actively cooled cover with specific mirrors on the inside to simulate the in flight background conditions. The cover can be actively cooled.

The cryostat provides the following major limitations which are relevant for the instrument testing

- Line of sight of LO beams between HIFI LOU and HIFI FPU is obstructed by the CVV window borders since it is not possible to move the optical bench such that the FPU LOS matches the window axes. Note: the EQM upper bulkhead design is identical to the PFM, i. e. designed to match the window axes at in flight conditions.

The SVM simulator consists of a platform with a support frame and provides all mechanical interfaces to support the warm unit EQMs/AVMs. The arrangement of the Warm Units on the SVM simulator is identical to the SVM PFM as far as the Warm Units are flight representative with respect to their interfaces.

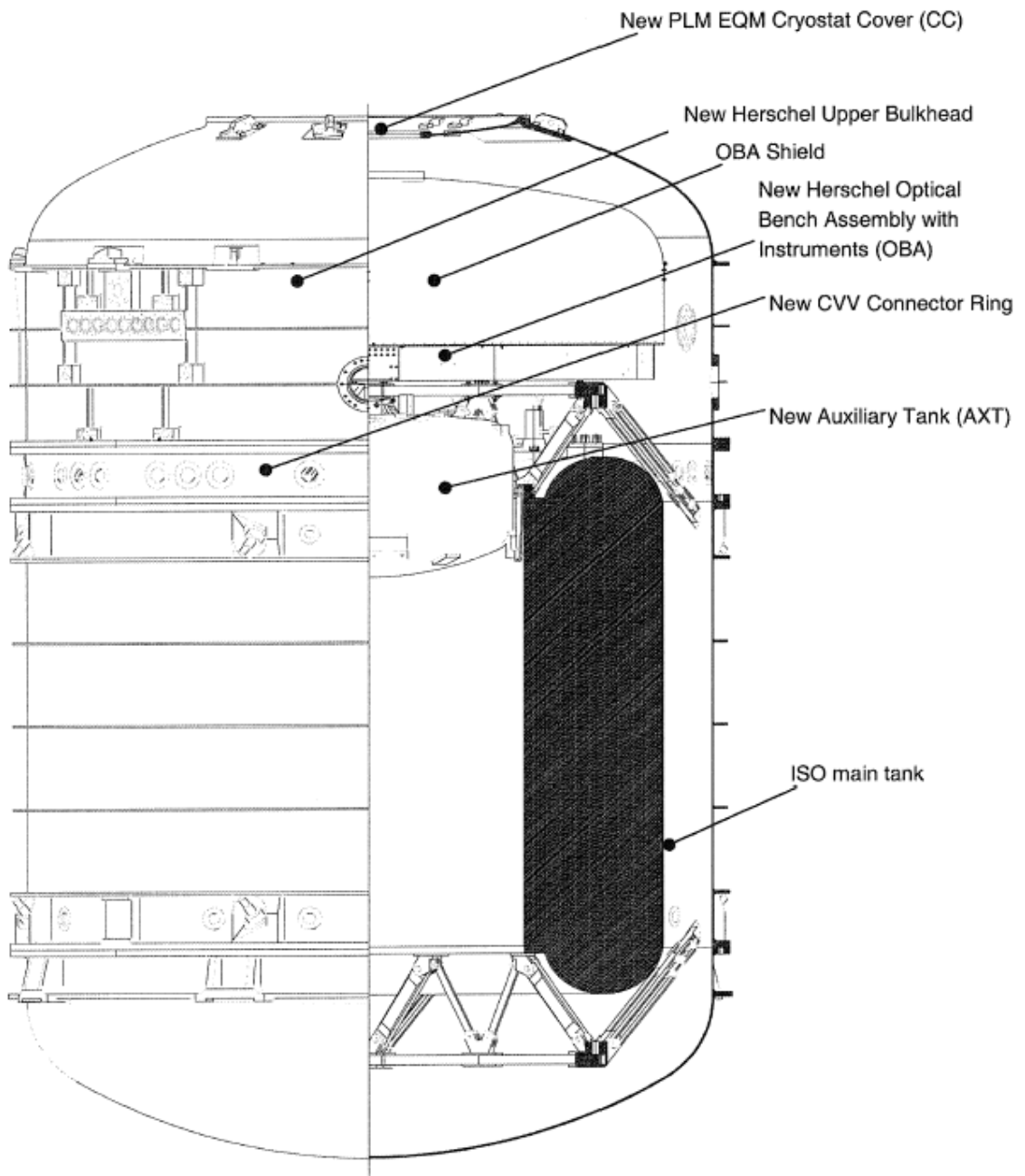

Figure 3.1-1: EQM Cryostat Configuration



### 3.2 Expected Instrument Steady State I/F Temperatures

	Interface	I/F Requirement for in-orbit		EQM
		Heat Load	Temperature	Temperature
<b>Level 0</b>	PACS Red Detector	0.8 mW	1.6 K ... 1.75 K	< 1.75 K
	PACS Blue Detector	2.0 mW	1.6 K ... 2 K	< 2 K
	PACS Cooler Pump	2.0 mW	1.6 K ... 5 K	< 2 K
		500 (peak) mW	1.6 K ... 10 K	< 10 K
	PACS Cooler Evapor.	15 mW	1.6 K ... 1.85 K	< 1.85 K
	SPIRE Detector	4 mW	< 2 K	< 2 K
		1 mW (goal)	< 1.71 K (goal)	< 1.71 K
	SPIRE Cooler Pump	2 mW	< 2 K	< 2 K
		500 mW (peak)	< 10 K (peak)	< 10 K
	SPIRE Cooler Evap.	15 mW	< 1.85 K	< 1.85 K
		15 mW (goal)	< 1.75 K (goal)	< 1.75 K
	HIFI Detector	6.8 mW	< 2 K	< 2 K
<b>Level 1</b>	PACS FPU	30 mW	2 K ... 5 K	2-5 K *
	SPIRE FPU	15 mW	< 5.5 K	< 5.5 K *
		13 mW (goal)	< 3.7 K (goal)	< 3.7 K *
	HIFI L1	15.5 mW	< 6 K	< 6 K
<b>Level 2</b>	OBP near PACS	0 mW	< 12 K	< 16 K
	OBP near SPIRE	0 mW	< 12 K	< 16 K
		0 mW (goal)	< 8K (goal)	
	Instr. Shield / SPIRE	0 mW	< 16 K	< 20 K
	HIFI FPU	22 mW	< 20 K	< 20 K
<b>Level 3</b>	SPIRE PM-JFET	50 mW	< 15 K	< 20 K
	SPIRE SM-JFET	25 mW	< 15 K	< 20 K
<b>LOU</b>	LOU (HIFI)	7000 mW	90 K ... 150 K	< 300 K

\*) The values apply to the Level 1 I/F. The FPU housings itself might be warmer because they are directly related to the absorptivity/emissivity of the FPU outer surfaces, which is outside of the responsibility of ASSED.

Table 3.2-1: Expected I/F Temperatures for EQM Testing in the Modified ISO Cryostat

Notes:

- The temperature values do not correspond to a similar helium mass flow rate as in orbit
- The AXT temperature will be adjusted to achieve Level 0 values
- The heat loads will be different compared to in orbit conditions due to higher Level 2 temperatures resulting from the CVV at room temperature (e.g. LOU windows)

## 4 PFM Thermal Testing with CVV at 293 K

### 4.1 PFM Objectives and Configuration

The main objective of the Instrument testing with CVV at ambient temperature is the verification of the functional performance of the integrated instruments in all possible modes. This includes the verification of the mechanical, thermal, electrical, electromagnetic and operational compatibility of the instruments with the satellite for on-ground conditions outside the TV chamber. Further objective is the verification of the instruments performance as far as possible in the existing ground test conditions. More detail about instrument testing are given in RD 03

### 4.2 Expected Steady State I/F Temperatures

#### 4.2.1 *Important Notes and Assumptions*

- The temperatures are based on analysis results obtained with H-EPLM TMM, Issue 4.0 (see RD 4) and are provided without uncertainties. The predicted IMT interface temperatures will be verified during STM testing and may require to be updated.
- Heat flows are dominated by radiation due to ambient temperature of the cryostat vacuum vessel at 293K.
- The He-II tank is in closed condition assuming a starting temperature of 1.7 K, increasing with a small gradient.
- The helium flow for optical bench cooling comes out of the HOT with 4.3 K. Variation of the He flow could be possible. Current assumption is 100mg/sec for about 10 h maximum. Then a refill is necessary.
- The cryo cover is cooled to approximately 80 K.

#### 4.2.2 *PACS Interface Temperatures*

The PACS instrument TMM thermal network is illustrated in Figure 4.2-1. More details about the TMM are given in RD 01. The PACS interface temperatures on-ground for the required in-orbit heat loads are compiled in Table 4.2-1.

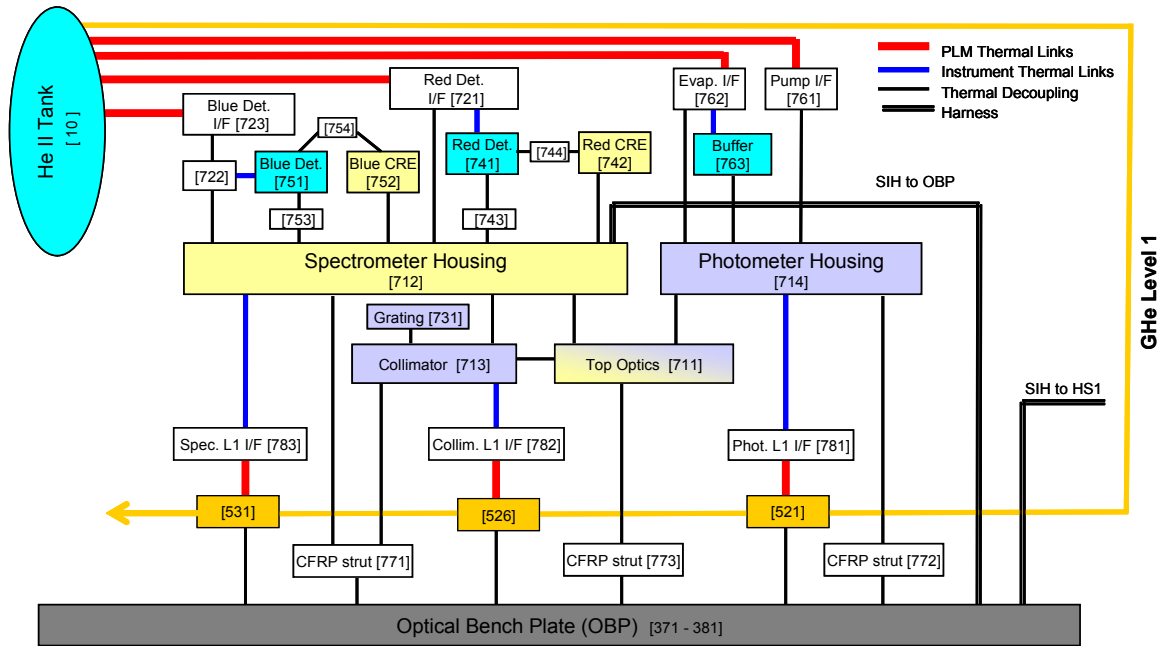

Figure 4.2-1: Reduced PACS Instrument TMM

PACS FPU Thermal I/F Interface		PACS I/F Requirement for In-Orbit		Predicted On-Ground I/F Temperature	
	TMM node	Heat Load	Temperature		
L0	Red Detector	721	0.8 mW	1.6 K ... 1.75 K	1.8 K
	Blue Detector	723	2.0 mW	1.6 K ... 2 K	2 K
	Cooler Pump	761	2.0 mW	1.6 K ... 5 K	2 K
	Cooler Evaporator	762	500 (peak) mW	1.6 K ... 10 K	15 K peak
L1	FPU I/F	783	30 mW	2 K ... 5 K	5.3 K
L2	Optical bench / FPU legs		0	<12 K	12 K

Notes:

- The L1 interface temperature (node 783) is calculated for the PACS Spectrometer Mode using the reduced PACS TMM as described in RD 01. The L1 Node 712 (spectrometer housing) has a temperature of about 6 K based on the analysis results. The L1 temperature is directly related to the absorptivity/emissivity of the FPU instrument surface, which is outside the responsibility of the ASED. The basis for PACS is an ASED made GMM of the FPU with an emissivity of 0.26.
- The evaporator interface temperature can be only achieved when the “open pod” is filled with superfluid Helium.

Table 4.2-1: PACS Thermal Interface Temperatures for On-Ground Instrument Testing

### 4.2.3 SPIRE Interface Temperatures

The SPIRE instrument TMM thermal network is illustrated in Figure 4.2-1. More details about the TMM are given in RD 01. The SPIRE interface temperatures on-ground for the required in-orbit heat flows are compiled in Table 4.2-1.

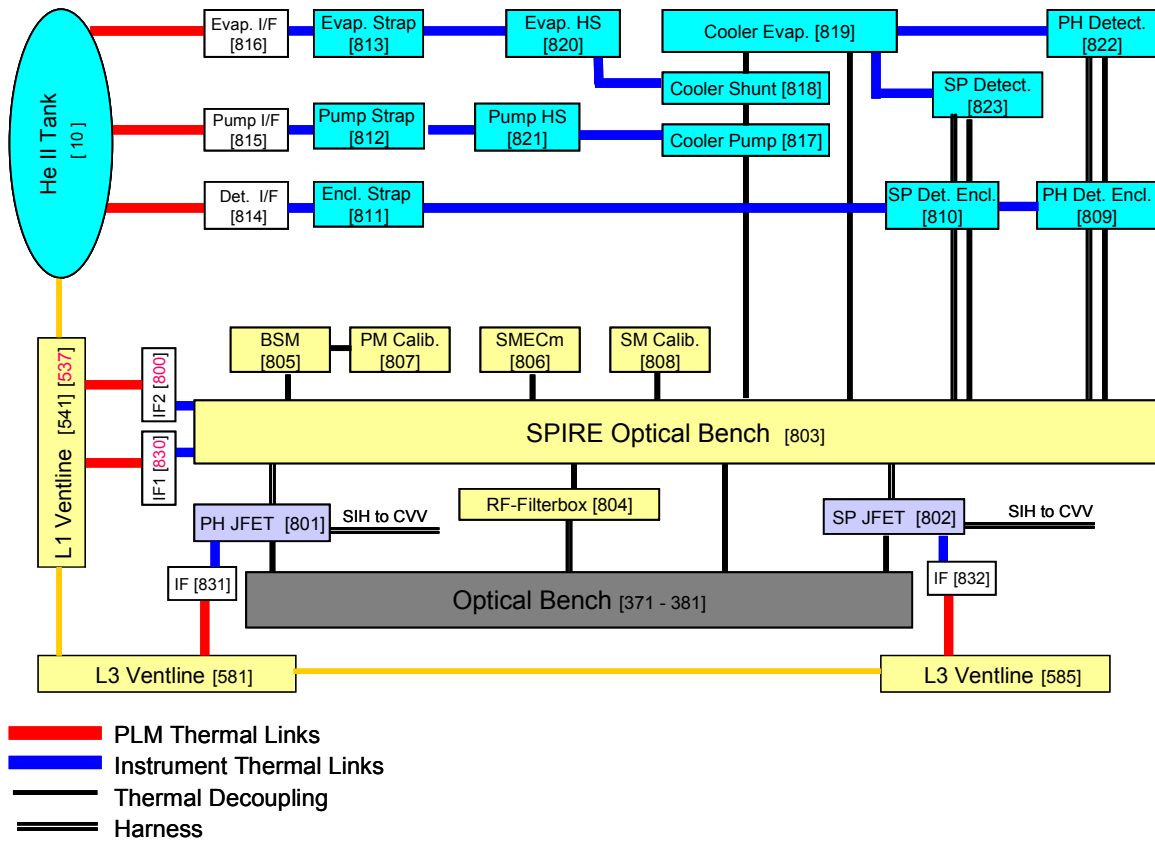

Figure 4.2-1: Reduced SPIRE Instrument TMM

SPIRE FPU thermal I/F Interface			SPIRE I/F Requirement for In-Orbit		Predicted On-Ground I/F Temperature
	TMM node	Heat Load	Temperature		
L0	Detector Box	814	4 mW	< 2 K	≤ 2 K
	Cooler Pump	815	2 mW	< 2 K	≤ 2 K
			500 mW (peak)	< 10 K (peak)	25 K peak
Cooler Evaporator	816	15 mW	< 1.85 K	≤ 2 K	
L1	L1 strap I/F	800	15 mW	< 5.5 K	6.2 K
L2	Optical bench / FPU legs		0 mW	< 12 K	≤ 12 K
L3	HSJFP (JFET Photometer)		50 mW	< 15 K	≤ 15 K
	HSJFS (JFET Spectrometer)		25 mW	< 15 K	≤ 15 K
-	Instrument shield		0 mW	< 16 K	≤ 16 K

## Notes:

- The interface temperatures are calculated for the SPIRE Spectrometer Mode using the reduced SPIRE TMM as described in RD 01. The temperature of the FPU housing itself (node 803) is calculated to 7.3 K. The L1 temperature is directly related to the absorptivity/ emissivity of the FPU instrument surface, which is outside the responsibility of ASED. The basis for SPIRE is the ITMM, Issue 2.5 and the associated geometry model assuming an FPU emissivity of 0.2.
- The sorption cooler recycling phase is composed of 2 phases in sequence, as described in the SPIRE IID-B.
- Level 0 interfaces to the He-II tank are dipped into the fluid. During recycling of the SPIRE cooler it is assumed that the cryostat is tilted such that the top of the open pod is in contact with superfluid Helium.

Table 4.2-1: SPIRE Thermal Interface Temperatures for On-Ground Testing

The corresponding I/F temperatures and heat flow charts for the CVV internal and for the OBA with SPIRE in Spectrometer Mode are shown in Figure 4.2-2 and Figure 4.2-3.

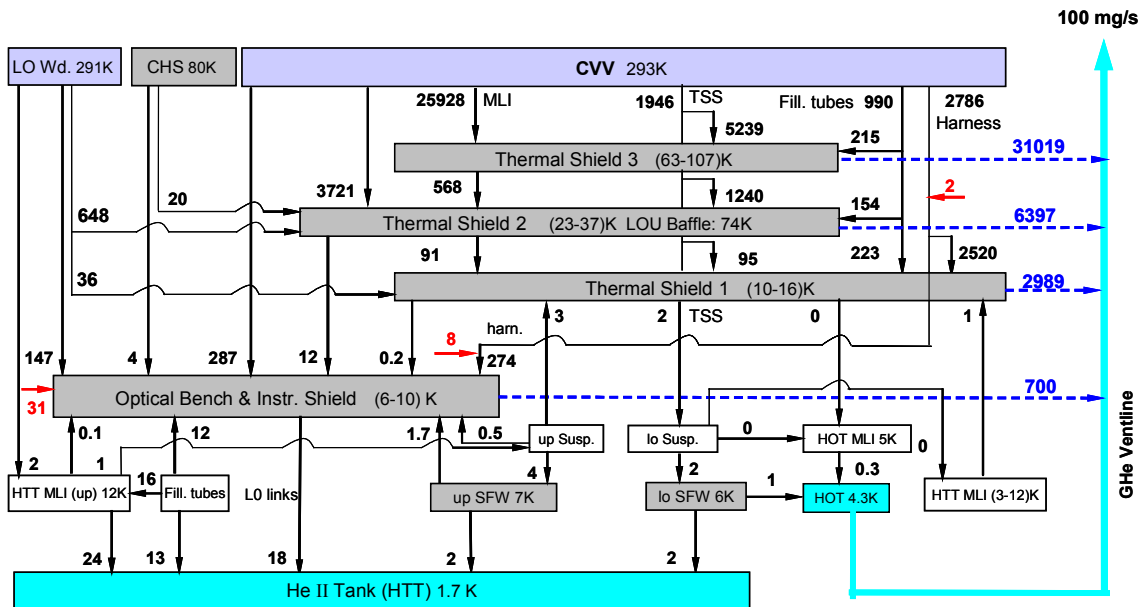

Only main paths are shown. All values are in [mW]

Figure 4.2-2: CVV Heat Flow Chart for IMT (Spire Spectrometer Mode)

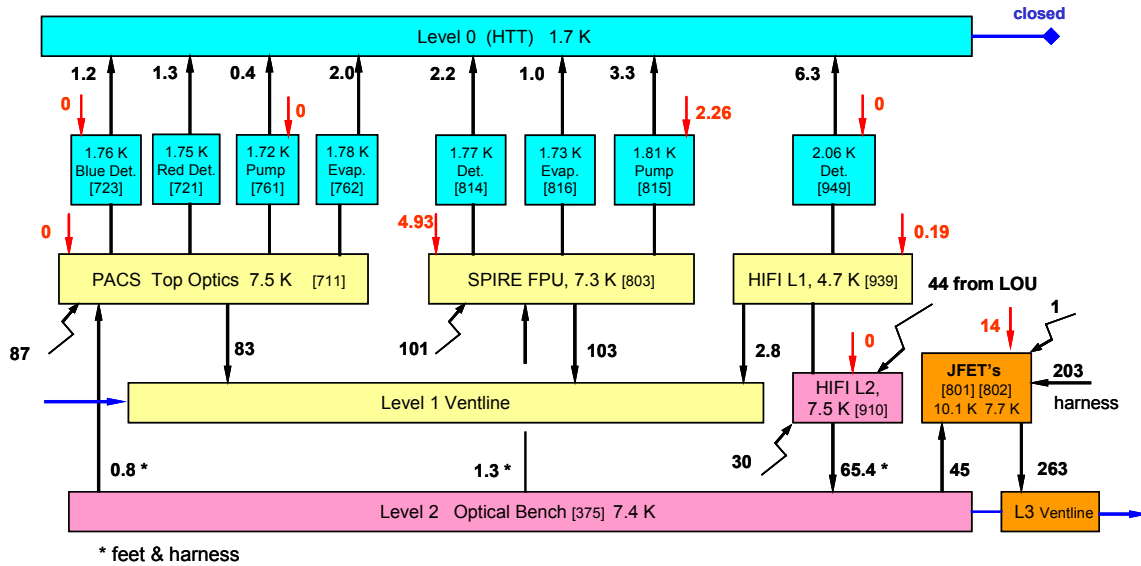

Figure 4.2-3: OBA Heat Flow Chart for IMT (SPIRE Spectrometer Mode)

4.2.4 HIFI Interface Temperatures

The HIFI instrument TMM thermal network is illustrated in Figure 4.3-3. More details about the TMM are given in RD 01. The HIFI interface temperatures on-ground for the required in-orbit heat flows are compiled in Table 4.2-1.

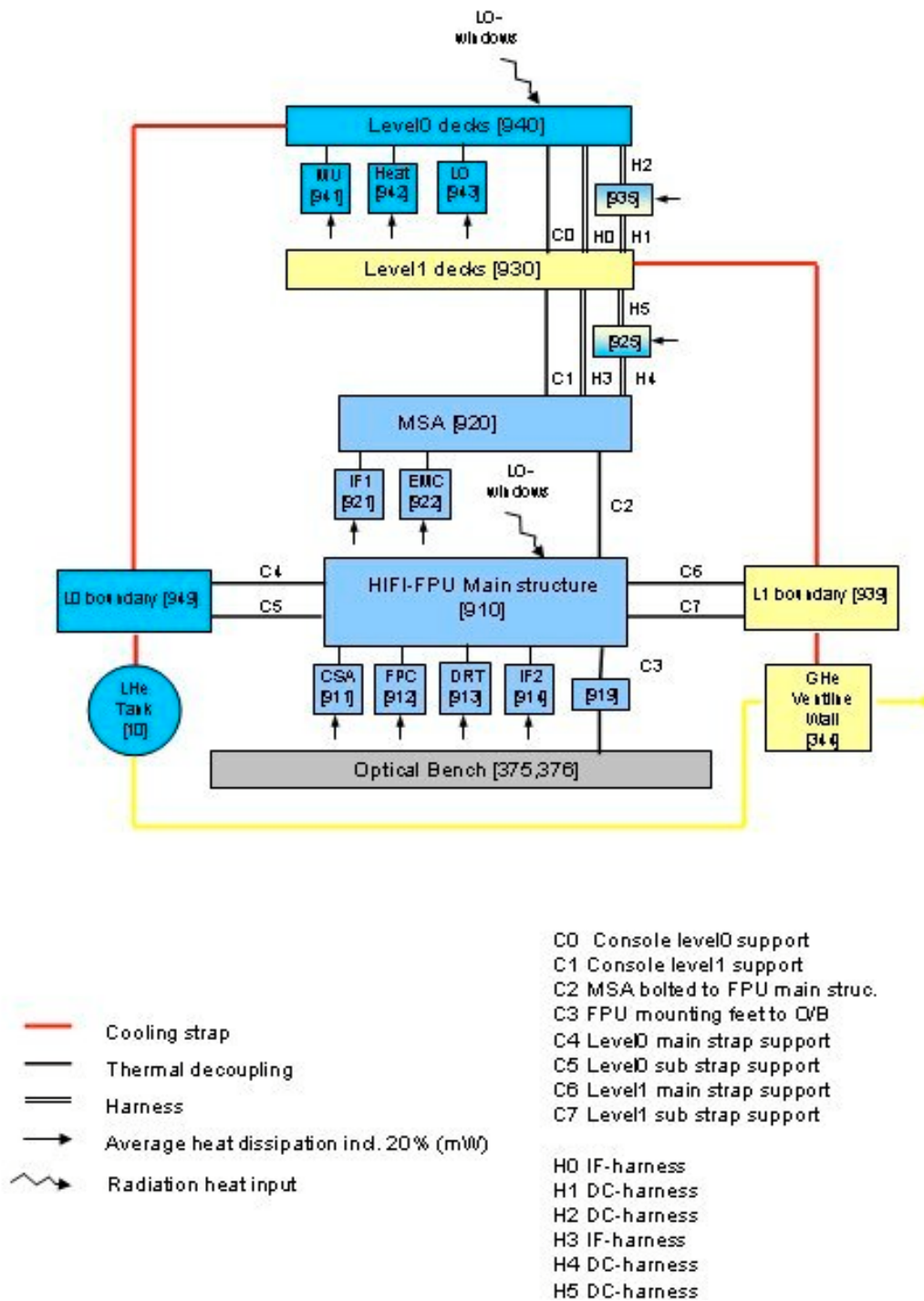

Figure 4.2-1: Reduced HIFI Instrument TMM

HIFI FPU Thermal I/F Interface			HIFI I/F Requirement for In-Orbit		Predicted On-Ground I/F Temperature
		TMM node	Heat Load	Temperature	
<b>L0</b>	L0 boundary	949	6.8 mW	< 2K	2.15 K
<b>L1</b>	L1 boundary	939	15.5 mW	< 6 K	5 K
<b>L2</b>	FPU structure	910	22 mW	< 20 K	12 K

Notes:

- The interface temperatures are calculated using the reduced HIFI TMM as described in RD 01. The L0 interface temperature (node 949) is calculated for Helium filling of 80% and upright cryostat position

Table 4.2-1: HIFI Thermal Interface Temperatures for On-Ground Testing

### 4.3 Transient Instrument Testing

For the Integrated Module Test (IMT) the same boundary conditions as for the steady state analyses in the previous section are assumed:

- HTT closed with start temperature: 1.7 K
- HOT He mass flow: 100 mg/s
- Temperature of HOT: 4.3 K (boundary)
- CVV temperature: 293 K (boundary)
- Cryo Cover cooled: 80 K (boundary)

The transient calculations have been performed assuming the instrument in-orbit timeline (see section 7.4 of RD 01) also for the IMT on-ground testing. The results are shown in Figure 4.3-1 until Figure 4.3-8.

It should be noted, that a permanent HOT mass flow of 100 mg/s is not realistic because the HOT will be operated about 10 hours per day. Then a refill is necessary. Detailed procedures for the HOT operation have to be agreed.



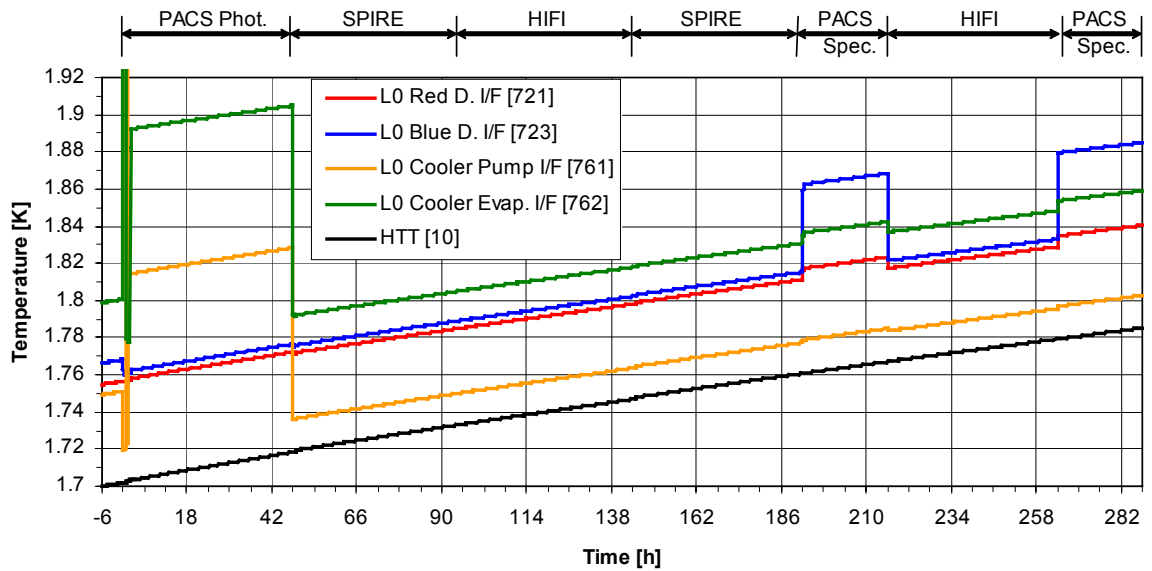

Figure 4.3-1: PACS L0 Interface Temperatures during IMT (based on orbit timeline)

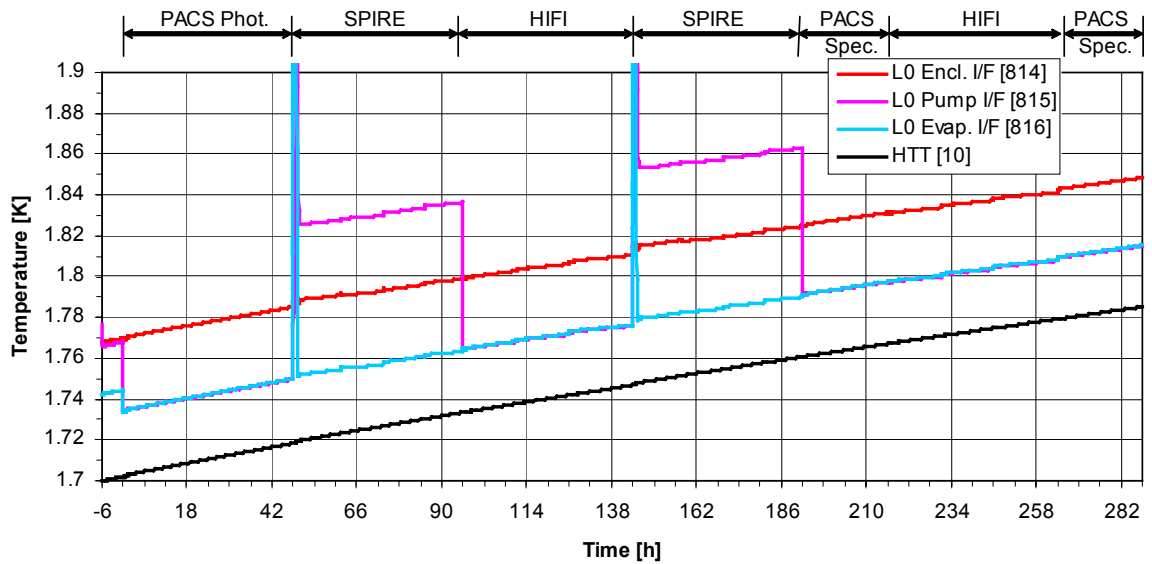

Figure 4.3-2: SPIRE L0 Interface Temperatures during IMT (based on orbit timeline)

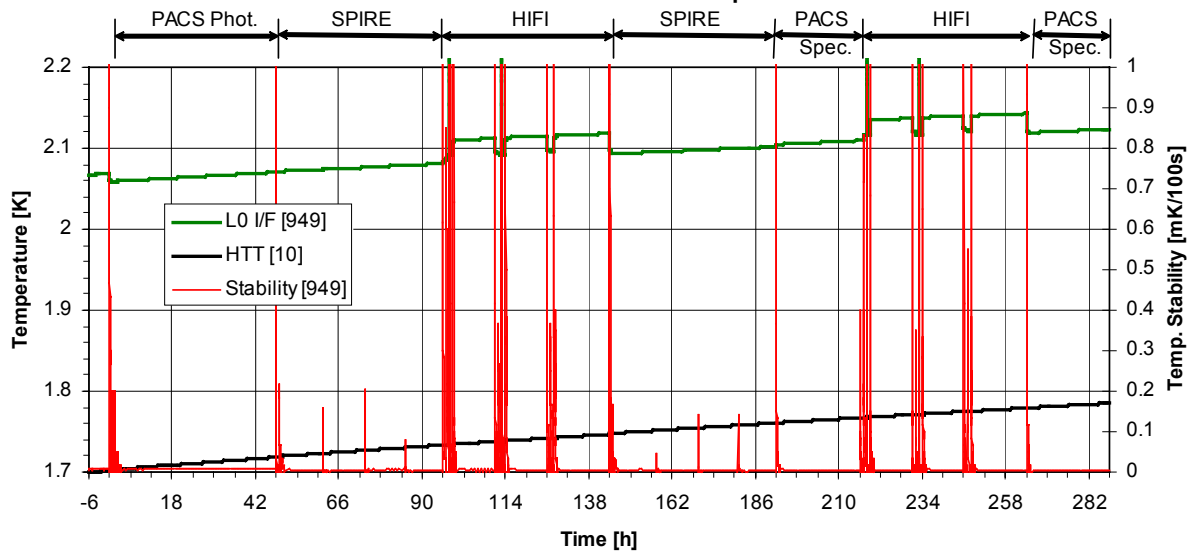

Figure 4.3-3: HIFI L0 Interface Temperatures during IMT (based on orbit timeline)

Note that the temperature change peaks of HIFI are caused by short heat peak phases due to dissipation switching.

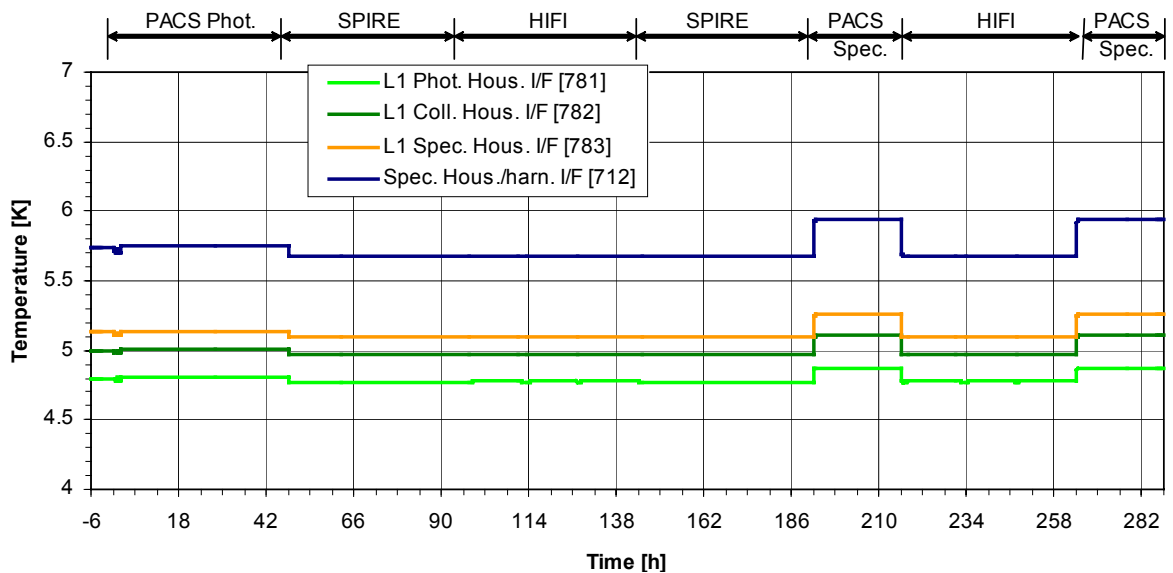

Figure 4.3-4: PACS L1 Interface Temperatures during IMT (based on orbit timeline)

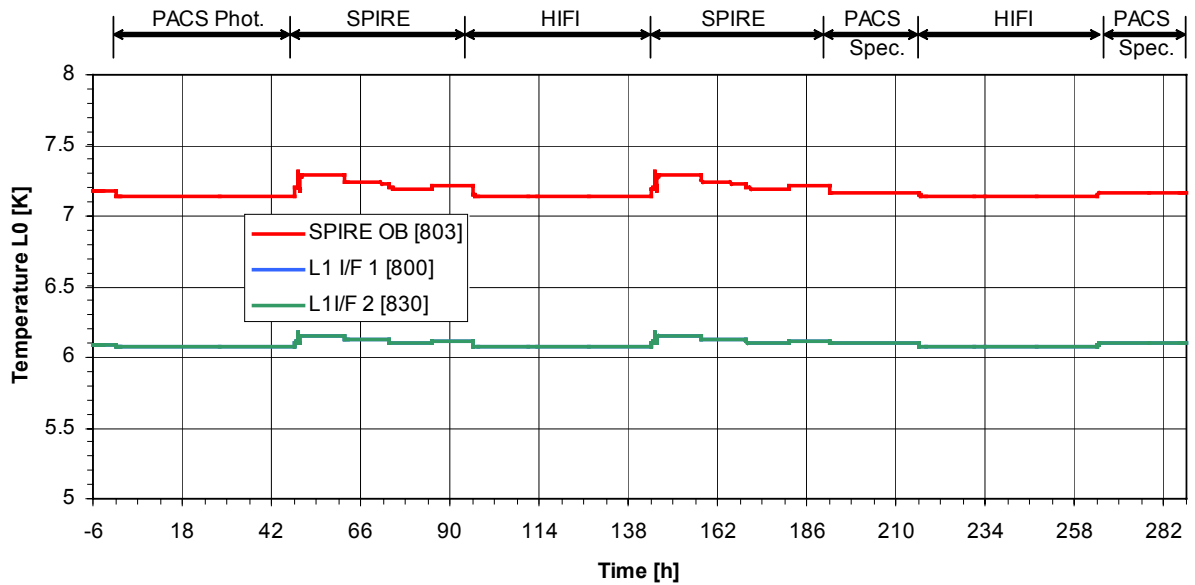

Figure 4.3-5: SPIRE L1 Interface Temperatures during IMT (based on orbit timeline)

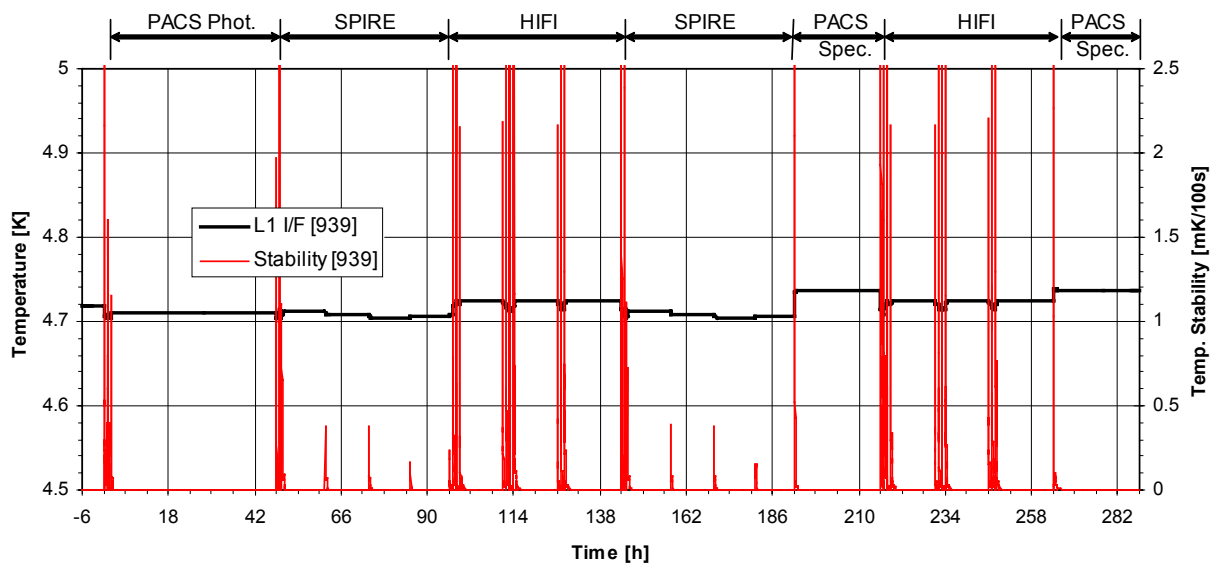

Figure 4.3-6: HIFI L1 Interface Temperature during IMT (based on orbit timeline)

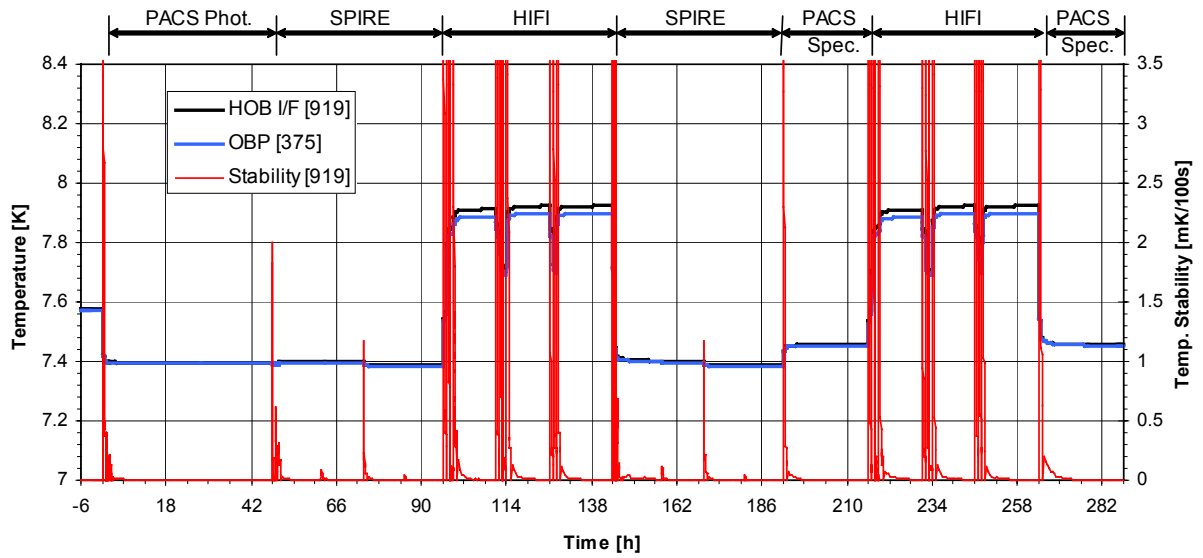

Figure 4.3-7: HIFI L2 and OBP Temperature during IMT (based on orbit timeline)

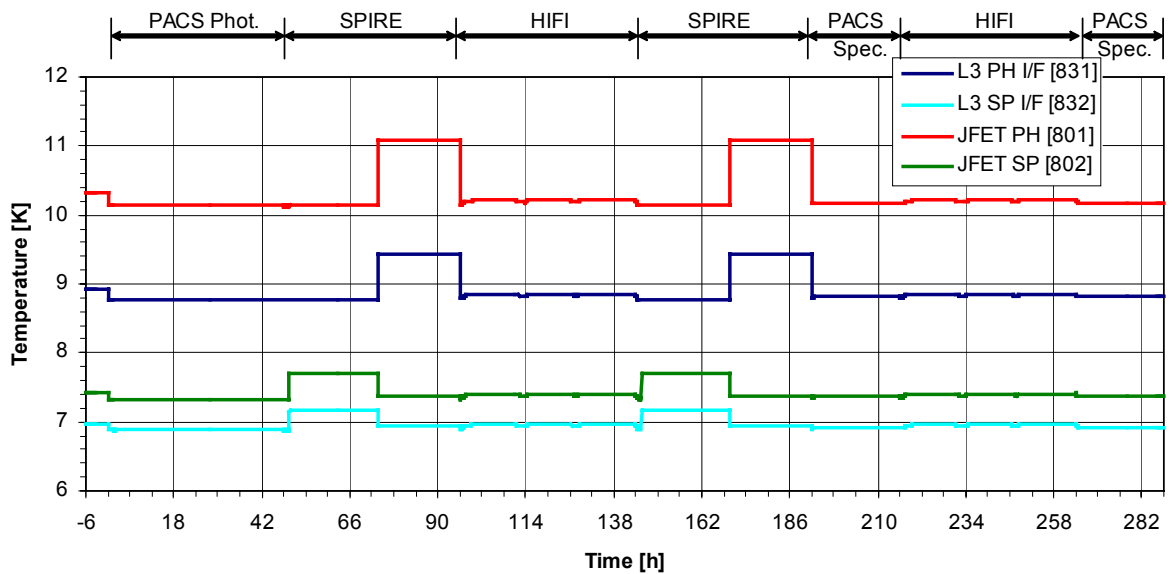

Figure 4.3-8: SPIRE L3 Temperatures during IMT (based on orbit timeline)

## **5 PFM TV Testing with CVV in LSS**

### **5.1 PFM Objectives and Configuration**

The main objective of the PLM PFM and satellite test programme is the flight acceptance of the satellite.

As regards the instruments this includes the verification of the mechanical, thermal, electrical, electromagnetic and operational compatibility of the instruments with the satellite in flight representative cryogenic conditions. Further objective is the verification of the instruments performance as far as possible in the existing ground test conditions. More detail about instrument testing are given in RD 03

### **5.2 Expected Interface Temperatures**

The instrument interface temperatures in the TV configuration inside the LSS are expected to be close to the in-orbit ones.

## 6 Thermal Environment during PFM Vibration Testing

### 6.1 Vibration Test Configuration

The PLM vibration test will be performed with the CVV at room temperature (293 K) and the HTT filled with normal fluid Helium. This means that the HTT is at about 4.3 K and evaporates against ambient pressure (i.e. no vacuum pump connected). The mass flow rate in this case is about 26 mg/s. The predicted instrument temperatures for this case are given in the following chapter for information.

### 6.2 Expected Instrument Temperatures during Vibration Test

The predicted instrument temperatures during PLM vibration test are shown in following Figure 6.2-1.

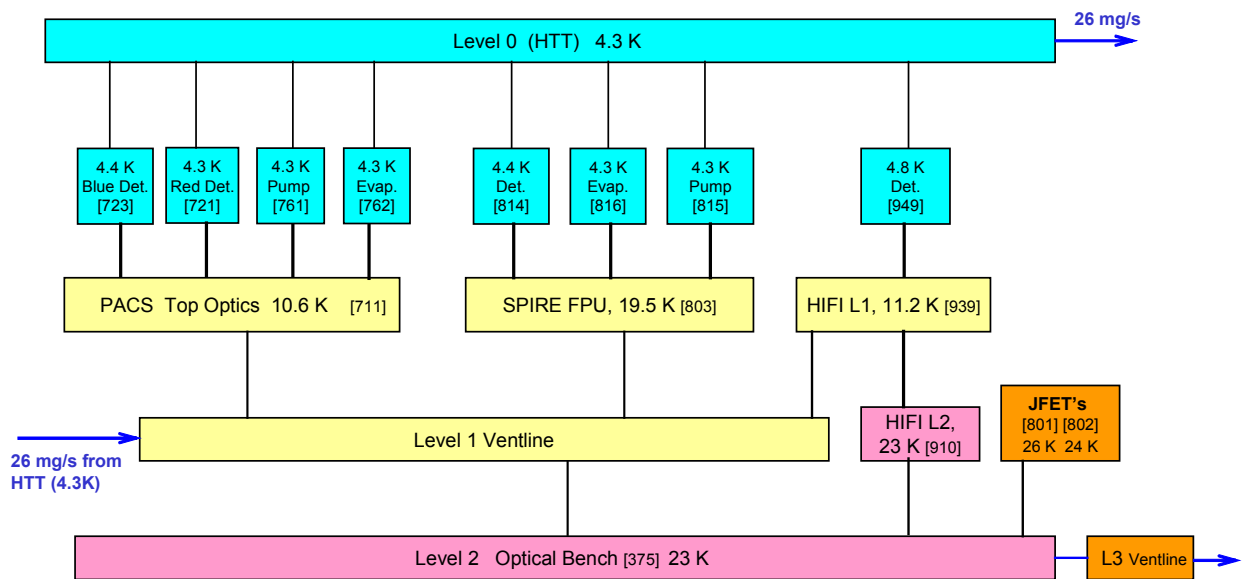

Figure 6.2-1: Instrument Temperatures during PLM Vibration Test

TMM Node	Label	Temperature [K]
711	Top Optic Housing	10.57
712	Spectrometer Housing	10.52
713	Collimator Housing	10.5
714	Photometer Housing	9.43
721	2K Feed-Through Red D	4.34
722	2K Feed-Through Blue D	5.31
723	2K StSt I/F Blue Det.	4.34
731	Grating Assy	10.5
741	Red Detector	4.94
742	Red Detector CRE	10.42
743	CFRP-Strut Red Det.	8.17
744	Harness Red Det. Int	8.23
751	Blue Detector	5.84
752	Blue Detector CRE	10.44
753	CFRP-Strut Blue Det.	8.51
754	Harness Blue Det. Int	8.51
761	Photometer Cooler Pump	4.31
762	Photometer Cooler Evap	4.32
763	Photometer Buffer	4.63
771	CFRP-Strut (OB) 1	18.01
772	CFRP-Strut (OB) 2	16.45
773	CFRP-Strut (OB) 3	18.02
781	Level 1,1 I/F	8.01
782	Level 1,2 I/F	9.05
783	Level 1,3 I/F	9.38

Table 6.2-1: Predicted PACS Temperatures during Vibration Test

TMM Node	Label	Temperature [K]
800	L1 Strap IF1 @ SOB	15.04
801	PH_JFET_ENCLOSURE	26.21
802	SP_JFET_ENCLOSURE	23.95
803	FPU_OPTICAL_BENCH	19.47
804	RF_FILTER_BOXES	19.48
805	BSM	19.47
806	SMECm	19.47
807	PH_CALIB	19.47
808	SPEC_CALIB	19.47
809	PH_DETECTOR_ENCLOSURE	5.05
810	SP_DETECTOR_ENCLOSURE	4.56
811	L0 Enclosure Flexible S	4.43
812	L0 Pump Flexible Strap	4.35
813	L0 Evap Flexible Strap	4.32
814	L0 Enclosure External S	4.4
815	L0 Pump External Strap	4.33
816	L0 Evaporator External	4.3
817	COOLER_PUMP	6.68
818	COOLER_SHUNT	4.35
819	COOLER_EVAP	5.32
820	COOLER_EVAP_HS	4.35
821	COOLER_PUMP_HS	4.37
822	PH_DETECTORS	5.32
823	SP DETECTORS	5.32
830	L1 Strap IF2 @ SOB	15.04
831	PH_L3 IF	24.92
832	SP_L3 IF	23.53

Table 6.2-2: Predicted SPIRE Temperatures during Vibration Test



TMM Node	Label	Temperature [K]
910	HIFI_FPU_Main_structure	22.88
911	Calibration_source_assem	22.88
912	Focal_Plane_Chopper	22.88
913	Diplexer_Rooftop_Transla	22.88
914	Second_stage_amplifier	22.88
919	L2-boundary	22.75
920	Mixer_Sub_Assembly	22.78
921	First_stage_amplifier	22.78
922	EMC-filtering	22.78
925	Magnet_current_dissipati	17.93
930	Console_level1_decks	11.25
935	Magnet_current_dissipati	8.76
939	L1_boundary	11.2
940	Console_level0_decks	4.77
941	Mixer_Unit	4.77
942	Heater	4.77
943	LO-power	4.77
949	L0-boundary	4.74

Table 6.2-3: Predicted HIFI Temperatures during Vibration Test

## 7 Conclusions

For the EQM campaign the predicted L0 and L1 instrument I/F temperatures are in line with the required in-orbit temperatures. The FPU housings itself might be warmer because they are directly related to the absorptivity/emissivity of the FPU outer surfaces, which is outside of the responsibility of ASED.

For the PFM IMT testing with CVV at room temperature the in-orbit required L0 I/F temperatures can be achieved for PACS and SPIRE except the peak temperature during sorption cooler recycling, which is considered as not critical. The predicted HIFI L0 temperature exceeds the in-orbit requirement by 0.15 K. For PACS and SPIRE The L1 I/F temperatures are slightly higher than the in-orbit required temperatures. It should be noted that the PACS and SPIRE FPU structures are about 1-2 K higher than the corresponding L1 I/F temperatures. The predicted L2 and L3 temperatures are in line with the corresponding in-orbit requirements.

END OF DOCUMENT

	Name	Dep./Comp.		Name	Dep./Comp.
	Alberti von Mathias Dr.	AOE22		Thörmer Klaus-Horst Dr.	OTN/AED65
	Alo Hakan	OTN/TP 45	X	Wagner Klaus	AOE23
	Barlage Bernhard	AED11	X	Wietbrock, Walter	AET12
X	Bayer Thomas	AET52		Wöhler Hans	AOE22
	Faas Horst	AEA65			
	Fehringer Alexander	AOE13			
	Frey Albrecht	AED422			
	Gerner Willi	AED11			
	Grasl Andreas	OTN/AET52			
	Grasshoff Brigitte	AET12	X	Alcatel	ASP
X	Hauser Armin	AOE23	X	ESA/ESTEC	ESA
	Hinger Jürgen	AOE23			
X	Hohn Rüdiger	AET52		<b>Instruments:</b>	
	Huber Johann	AOA4	X	MPE (PACS)	MPE
	Hund Walter	ASE4A	X	RAL (SPIRE)	RAL
X	Idler Siegmund	AED432	X	SRON (HIFI)	SRON
	Ivány von András	FAE22			
X	Jahn Gerd Dr.	AOE23		<b>Subcontractors:</b>	
	Kalde Clemens	APE3		Air Liquide, Space Department	AIR
	Kameter Rudolf	OTN/AET52		Air Liquide, Space Department	AIRS
	Kettner Bernhard	AOE22		Air Liquide, Orbital System	AIRT
	Knoblauch August	AET32		Alcatel Bell Space	ABSP
	Koelle Markus	AET22		Astrium Sub-Subsyst. & Equipment	ASSE
X	Kroeker Jürgen	AED65		Austrian Aerospace	AAE
	Kunz Oliver Dr.	AOE23		Austrian Aerospace	AAEM
	Lamprecht Ernst	OTN/ASI21		APCO Technologies S. A.	APCO
	Lang Jürgen	ASE4A		Bieri Engineering B. V.	BIER
X	Langfermann Michael	AET52		BOC Edwards	BOCE
	Mack Paul	OTN/AET52		Dutch Space Solar Arrays	DSSA
	Muhl Eckhard	OTN/AET52		EADS CASA Espacio	CASA
	Pastorino Michel	ASPI Resid.		EADS CASA Espacio	ECAS
	Peltz Heinz-Willi	AET42		EADS Space Transportation	ASIP
	Pietroboni Karin	AED65		Eurocopter	ECD
	Platzer Wilhelm	AED22		HTS AG Zürich	HTSZ
	Rebholz Reinhold	AET52		Linde	LIND
	Reuß Friedhelm	AED62		Patria New Technologies Oy	PANT
	Rühe Wolfgang	AED65		Phoenix, Volkmarsen	PHOE
	Runge Axel	OTN/AET52		Prototech AS	PROT
	Sachsse Bernt	AED21		QMC Instruments Ltd.	QMC
X	Schink Dietmar	AED422		Rembe, Brilon	REMB
X	Schlosser Christian	OTN/AET52		Rosemount Aerospace GmbH	ROSE
	Schmidt Rudolf	FAE22		RYMSA, Radiación y Microondas S.A.	RYM
	Schweickert Gunn	AOE22		SENER Ingeniería SA	SEN
	Stauss Oliver	AOE13		Stöhr, Königsbrunn	STOE
	Steininger Eric	AED422		Terma A/S, Herlev	TER
X	Stritter Rene	AED11		European Test Services	ETS
	Tenhaeff Dieter	AOE22			