

# SPIRE

**SUBJECT: SPIRE Warm Electronics Handling and Integration Procedure**

**PREPARED BY: E Sawyer**

**DOCUMENT No: SPIRE-RAL-PRC-002181**

**ISSUE: 1**

**Date: 14/10/04**

**CHECKED BY: .....**

**Date: .....**

**APPROVED BY: .....**

**Date: .....**

**SPIRE**

**Project Document**

SPIRE Warm Electronics Handling and  
Integration Procedure

**Ref:** SPIRE-RAL-PRC-  
002181

**Issue:** 1

**Date:** 14/10/04

**Page:** 2 of 10

---

---

**Distribution**

**SPIRE**

**Project Document**

SPIRE Warm Electronics Handling and  
Integration Procedure

**Ref:** SPIRE-RAL-PRC-  
002181

**Issue:** 1

**Date:** 14/10/04

**Page:** 3 of 10

---

---

**Change Record**

ISSUE

1

DATE

14/10/04

First issue

## Table of Contents

<b>SPIRE</b> .....	<b>1</b>
<b>SPIRE WARM ELECTRONICS HANDLING AND INTEGRATION PROCEDURE</b> .....	<b>1</b>
<b>CHANGE RECORD</b> .....	<b>3</b>
<b>TABLE OF CONTENTS</b> .....	<b>4</b>
<b>REFERENCES</b> .....	<b>5</b>
<b>APPLICABLE DOCUMENTS</b> .....	<b>5</b>
<b>1. INTRODUCTION</b> .....	<b>6</b>
<b>2. SCOPE</b> .....	<b>6</b>
<b>3. DELIVERY CONDITION</b> .....	<b>6</b>
3.1 SHOCK RECORDERS .....	<b>6</b>
<b>4. TRANSPORT</b> .....	<b>6</b>
4.1 IN DEDICATED EXPERIMENT CONTAINERS .....	<b>6</b>
4.2 AFTER INTEGRATION ON THE SPACECRAFT (IN SPACECRAFT CONTAINER) .....	<b>6</b>
<b>5. STORAGE</b> .....	<b>7</b>
5.1 IN DEDICATED EXPERIMENT CONTAINER .....	<b>7</b>
5.2 OUT OF CONTAINER (IN RR100 CLEANROOM, AWAITING INTEGRATION) .....	<b>7</b>
<b>6. HANDLING</b> .....	<b>7</b>
6.1 GENERAL .....	<b>7</b>
6.2 ESD PROTECTION .....	<b>7</b>
6.3 UNPACKING FROM DEDICATED EXPERIMENT CONTAINER .....	<b>7</b>
6.4 PREPARATION FOR INTEGRATION .....	<b>8</b>
6.5 PREPARATION FOR PACKING .....	<b>8</b>
6.6 PACKING IN CONTAINERS .....	<b>8</b>
<b>7. INTEGRATION</b> .....	<b>8</b>
7.1 REQUIRED TOOLS/MGSE .....	<b>8</b>
7.2 MECHANICAL INTEGRATION TO SPACECRAFT .....	<b>9</b>
7.3 ELECTRICAL INTEGRATION .....	<b>9</b>
7.4 REMOVAL FROM SPACECRAFT .....	<b>9</b>
<b>8. RED TAG ITEMS</b> .....	<b>9</b>
<b>9. GREEN TAG ITEMS</b> .....	<b>9</b>
<b>10. ANNEX A - INTERFACE DRAWINGS</b> .....	<b>10</b>

## References

### **Applicable Documents**

AD1	SPIRE-RAL-PRC-001923	FPU handling and integration procedure.
AD2		
AD3	SAP-SPIRE-CB-0120-03	DCU QM1 and FCU QM1 packaging, unpacking and handling procedure

### **Reference Documents**

## 1. INTRODUCTION

## 2. SCOPE

This document describes the procedures to be followed when handing the SPIRE Warm electronics units after delivery to ESA/Alcatel.

It covers the handling and integration procedures to be followed for the following units:

HSDPU Herschel Spire Digital Processor Unit  
HSFCU Herschel Spire Focal plane Control Unit  
HSDCU Herschel Spire Detector Control Unit

It covers both the CQM and PFM units

## 3. DELIVERY CONDITION

The SPIRE instrument warm units will be delivered in the following condition:-

The units will be supplied in dedicated, re-useable, containers.

### 3.1 Shock recorders

Attached to the outside of the transportation containers are shock indicators

Upon inspection, if any of these recorders have triggered the project team at RAL should be informed.

## 4. TRANSPORT

### 4.1 In dedicated experiment containers

Protect from rain and moisture.

Transport in closed vehicles only.

Protect from extremes of temperature, -10°C to +50°C, and prevent the formation of dew at any time.

### 4.2 After integration on the spacecraft (in spacecraft container)

Equivalent to Cleanroom 10,000 conditions for FM

No cleanliness requirements for QM units

No other specific requirement.

## 5. STORAGE

### 5.1 In dedicated experiment container

Protect from rain and moisture.

Protect from extremes of temperature, 10°C to +30°C.

### 5.2 Out of container (in RR100 cleanroom, awaiting integration)

No specific requirement.

## 6. HANDLING

### 6.1 General.

The SPIRE warm electronics units are typical of any spacecraft electronics units with only the normal handling requirements.

These units are ESD sensitive.

### 6.2 ESD protection

All the units are sensitive to ESD.

In particular, the SPIRE DCU contains very sensitive detector electronics that are susceptible to damage by Electro static discharge.

On delivery all connectors will be protected by covers.

When handling, all personnel shall wear anti static protection (wrist straps or other suitable method)

### 6.3 Unpacking from dedicated experiment container.

Before any entrance in a clean room, the container must be cleaned with isopropyl alcohol.

The containers of the QM units can be opened outside a clean room, in an area whose environment isn't controlled.

Before opening the container, the following checks must be carried:

- Checking of the external condition of the container.
- Checking of the sealed integrity.
- Checking the presence of shock detectors and their states (nominal colour: white).

Remove the seals.

Open the container.

Inspect the condition of the inside of the container.

Remove unit from the container and from the antistatic bag.

Check of the external condition of the units

Close the container and store it in a clean location.

Record the operations in the logbook.

#### 6.4 Preparation for integration.

No specific activities

#### 6.5 Preparation for packing.

No specific activities

#### 6.6 Packing in containers.

Package unit into its antistatic bag. Purge with dry nitrogen and sealed the bag.

- Place unit into the container.
- Put a new dessicator in the container.
- Put a new humidity indicator (nominal colour : blue)
- Close the container.
- Verify the presence of shock detectors outside the container and their states (nominal colour: white).  
If necessary, replace the shock detectors.
- Install the seals
- Record the operations in the logbook.

### 7. INTEGRATION

#### 7.1 Required tools/MGSE

SPIRE supplied tools/MGSE:-

Antistatic bag for repacking  
Desiccators for repacking  
Humidity indicators  
Shock detectors

Supplied by spacecraft

Dry nitrogen set up for repacking  
Isopropyl alcohol  
Earth conductor bracelets  
Fixation bolts,  
Torque wrench to cover 1.5 to 8.25 Nm  
Allan key, spanners etc  
DVM for electrical isolation testing



## 7.2 Mechanical integration to spacecraft.

All the warm electronics units are mounted to the SVM panel with a number of standard fasteners as follows:

UNIT and Model	Fastener size	Qty
DPU QM	M4	6
DCU QM1	M5	6
FCU QM1	M5	4
DPU FM	M4	6
DCU QM2 and FM	M4	12
FCU QM2 and FM	M5	12

The units shall be placed on the panel and attached with the fasteners. Fasteners to be torqued in accordance with Astrium procedures.  
No special procedure is foreseen.

## 7.3 Electrical integration

Refer to AD1 for electrical integration procedures.

## 7.4 Removal from spacecraft.

Removal is the reverse of the integration procedure.

## 8. RED TAG ITEMS

There are no red tag items

## 9. GREEN TAG ITEMS

There are no green tag items

**SPIRE**

**Project Document**

SPIRE Warm Electronics Handling and  
Integration Procedure

**Ref:** SPIRE-RAL-PRC-  
002181

**Issue:** 1

**Date:** 14/10/04

**Page:** 10 of 10

**10. ANNEX A - INTERFACE DRAWINGS**

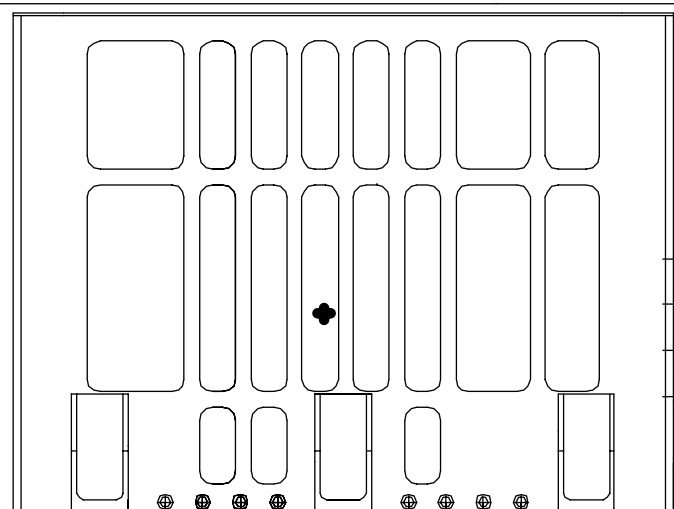
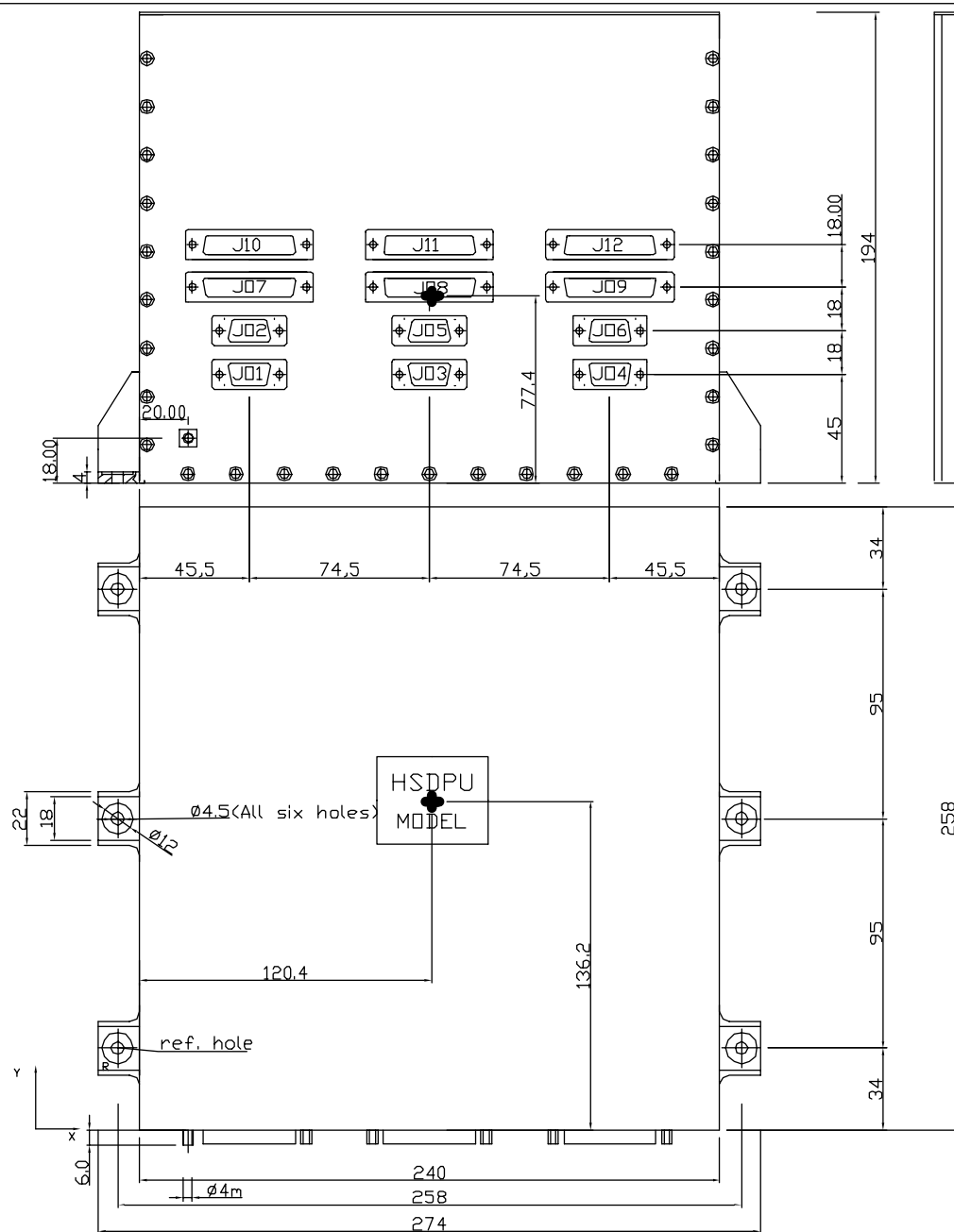

GENERAL TOLERANCE  $\pm 1\text{mm}$   
 WEIGHT 7.177 Kg  $\pm 200\text{g}$   
 DIMENSION 274 X 258 X 194mm  
 CENTRE OF GRAVITY (E): X=120,4; Y=136,2;  
 Z=77,4  
 MOMENT OF INERTIA (E): Jx=6,23X10<sup>-2</sup> Kg<sup>m2</sup>  
 Jy=5,73X10<sup>-2</sup> Kg<sup>m2</sup>  
 Jz=7,70X10<sup>-2</sup> Kg<sup>m2</sup>

CASING MATERIAL: ANTICORDDAL 6082  
 SURFACE TREATMENT: ALODINE 1200:  
 alfa solar = 0,604  
 R-solar = 0,396  
 epsilon IR = 0,172  
 R-IR = 0,828

THERMAL CAPACITANCE: 7.177J/°C (E)  
 CONTACT AREA OF BASEPLATE PLUS FEET 64428mm<sup>2</sup>  
 FLATNESS OF MOUNTING AREA: 0.1mm/100mm

CONNECTORS:  
 J01= DEMA-9P From DPU Prime to PDU Prime  
 J02= DEMA-9P From DPU Red. to PDU Red.  
 J03= DEMA-9S From DPU Prime to Bus A Prime  
 J04= DEMA-9S From DPU Prime to Bus B Prime  
 J05= DEMA-9S From DPU Red. to Bus A Red.  
 J06= DEMA-9S From DPU Red. to Bus B Red.  
 J07= DBMA-25P From DPU Prime to DCE Prime  
 J10= DBMA-25P From DPU Red. to DCE Red.  
 J08= DBMA-25P From DPU Prime to MCE Prime  
 J11= DBMA-25P From DPU Red. to MCE Red.  
 J09= DBMA-25P From DPU Prime to SCE Prime  
 J12= DBMA-25P From DPU Red. to SCE Red.

UPDATED: 23/02/2003 P. Baldetti (rev. 4)  
 UPDATED: 10/02/2002 P. Baldetti (rev. 3)  
 UPDATED: 16/01/2002 P. Baldetti UPDATED: 29/01/2002 P. Baldetti

Consiglio Nazionale delle Ricerche Istituto di fisica dello SPAZIO INTERPLANETARIO Via del Fosso del Mulino n. 100 tel. 06/1993 per 06/1993333	data 5/04/2001 	prog. Baldetti scala	dis. materiale	
		tratt.		
	rev. 4 data 23/02/03	toll.	Progetto: HERSCHEL- HSDPU	
			titolo: HSDPU	N. dis HER S005/03

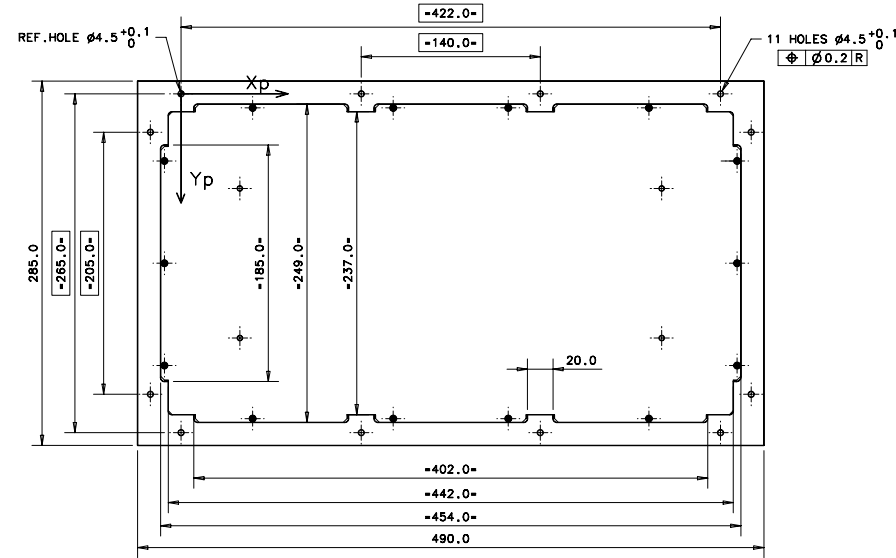
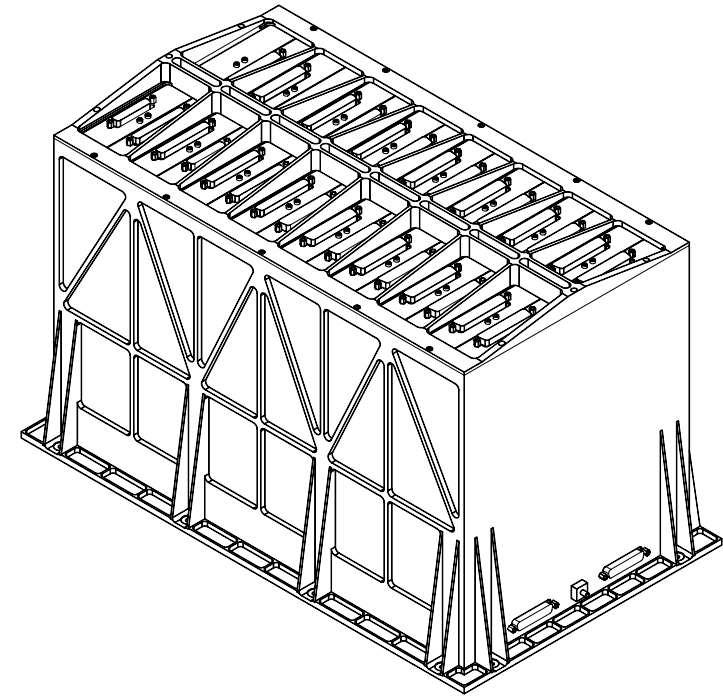

CONNECTORS					
IDENT	TYPE	FUNCTIONS	IDENT	TYPE	FUNCTIONS
J01	DBMA 25S	DAQ_IF_M/DPU_M	J17	DDMA 50P	LIA_P_7/FPU
J02	DBMA 25S	DAQ_IF_R/DPU_R	J18	DDMA 50P	LIA_P_7/FPU
J03	DBMA 25P	DCU/PSU_M	J19	DDMA 50P	LIA_P_8/FPU
J04	DBMA 25P	DCU/PSU_R	J20	DDMA 50P	LIA_P_8/FPU
J05	DDMA 50P	LIA_P_1/FPU	J21	DDMA 50P	LIA_P_9/FPU
J06	DDMA 50P	LIA_P_1/FPU	J22	DDMA 50P	LIA_P_9/FPU
J07	DDMA 50P	LIA_P_2/FPU	J23	DCMA 37P	LIA_S_1/FPU
J08	DDMA 50P	LIA_P_2/FPU	J24	DCMA 37P	LIA_S_1/FPU
J09	DDMA 50P	LIA_P_3/FPU	J25	DCMA 37P	LIA_S_2/FPU
J10	DDMA 50P	LIA_P_3/FPU	J26	DCMA 37P	LIA_S_2/FPU
J11	DDMA 50P	LIA_P_4/FPU	J27	DCMA 37P	LIA_S_3/FPU
J12	DDMA 50P	LIA_P_4/FPU	J28	DCMA 37P	LIA_S_3/FPU
J13	DDMA 50P	LIA_P_5/FPU	J29	DDMA 78S	BIAS_M/FPU
J14	DDMA 50P	LIA_P_5/FPU	J30	DDMA 78S	BIAS_R/FPU
J15	DDMA 50P	LIA_P_6/FPU	J31	DCMA 37S	BIAS_M/FPU
J16	DDMA 50P	LIA_P_6/FPU	J32	DCMA 37S	BIAS_R/FPU

NOTES

MATERIAL AL 6082  
 CENTRE OF GRAVITY REFERRED TO REFERENCE HOLE  
 X=213.2mm Y=132.4mm Z=157.9mm  
 MOMENTS OF INERTIA REFERRED TO CENTRE OF GRAVITY  
 Jxp=0.471 Kg.m2 Jyp=0.250 Kg.m2 Jzp=0.444 Kg.m2  
 CONTACT AREA MOUNTING FEET=28180mm2  
 THERMAL COATING AND BLACK ANODISING ESA.PSS.703  
 SURFACE EMISSIVITY >0.85  
 TORQUE VALUE FOR CONNECTOR FIXATION SCREWS=  
 - MALE=0.3mN  
 - FEMALE=0.45mN  
 SPECIFIC HEAT 1170 J/Kg.\*K  
 ESTIMATED MASS=14442g

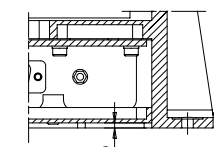
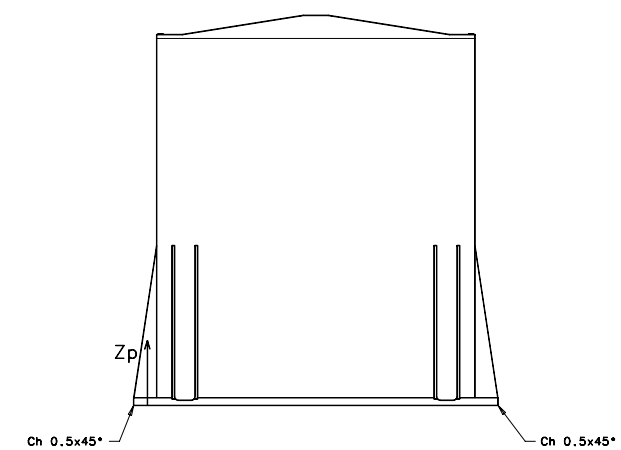
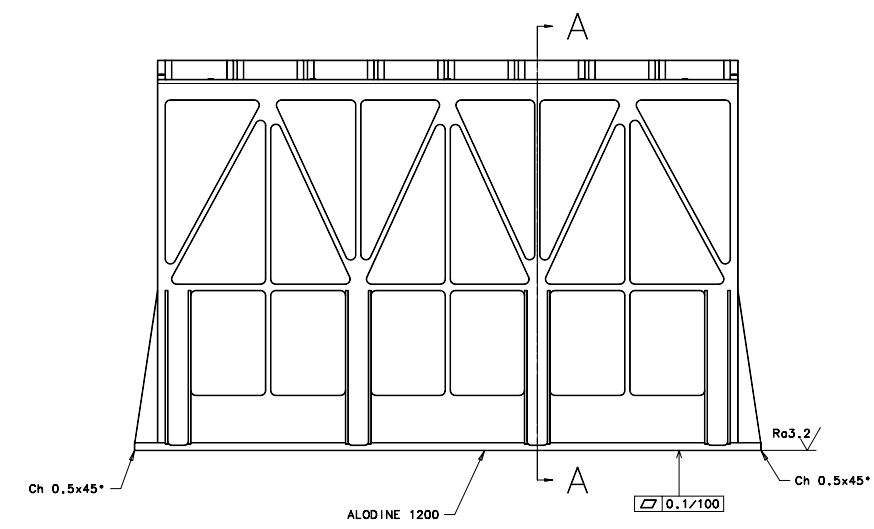
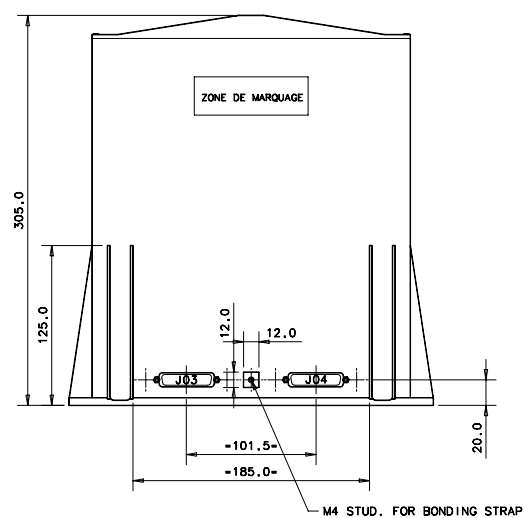

COUPE PARTIELLE A-A  
 ECHELLE:1/1

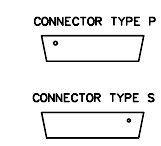
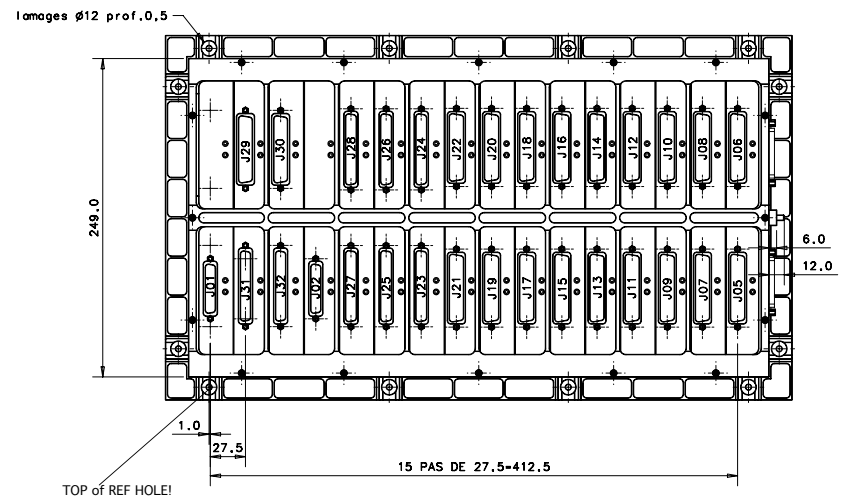

Indice	Modifications	Date	Dessiné par	Vérifié par	Approuvé par
E	Mise à jour	01/04	DHENAIN		
D	Ajout coupe A-A	10/02	DHENAIN		
C	Mise à jour	09/02	DHENAIN		
B	Mise à jour	06/02	DHENAIN		
A	Origine	11/01	DHENAIN		

tolérances générales	Indice de rugosité général XXX	SOUS-TRAITANT
	Tol. ang.: <math>\pm 0.1^\circ</math>	
	Casser les angles vifs	
Matière:	First angle Projection	
Traitement thermique:	Echelle 1/2	Poids Niveau qualité

**SPIRE HSDCU ELECTRONIC BOX MECHANICAL INTERFACE CONTROL DRAWING**

Il n'est permis d'utiliser ce dessin qu'avec l'autorisation expresse - tel du 11 mars 1987

SAP/GERES	COMMISSARIAT A L'ENERGIE ATOMIQUE	C.E.N. SACLAY
Tel: 01.69.08.78.25	01.69.08.59.76	Fax: 01.69.08.79.96
AO		SPIR-MX-5100 000 E

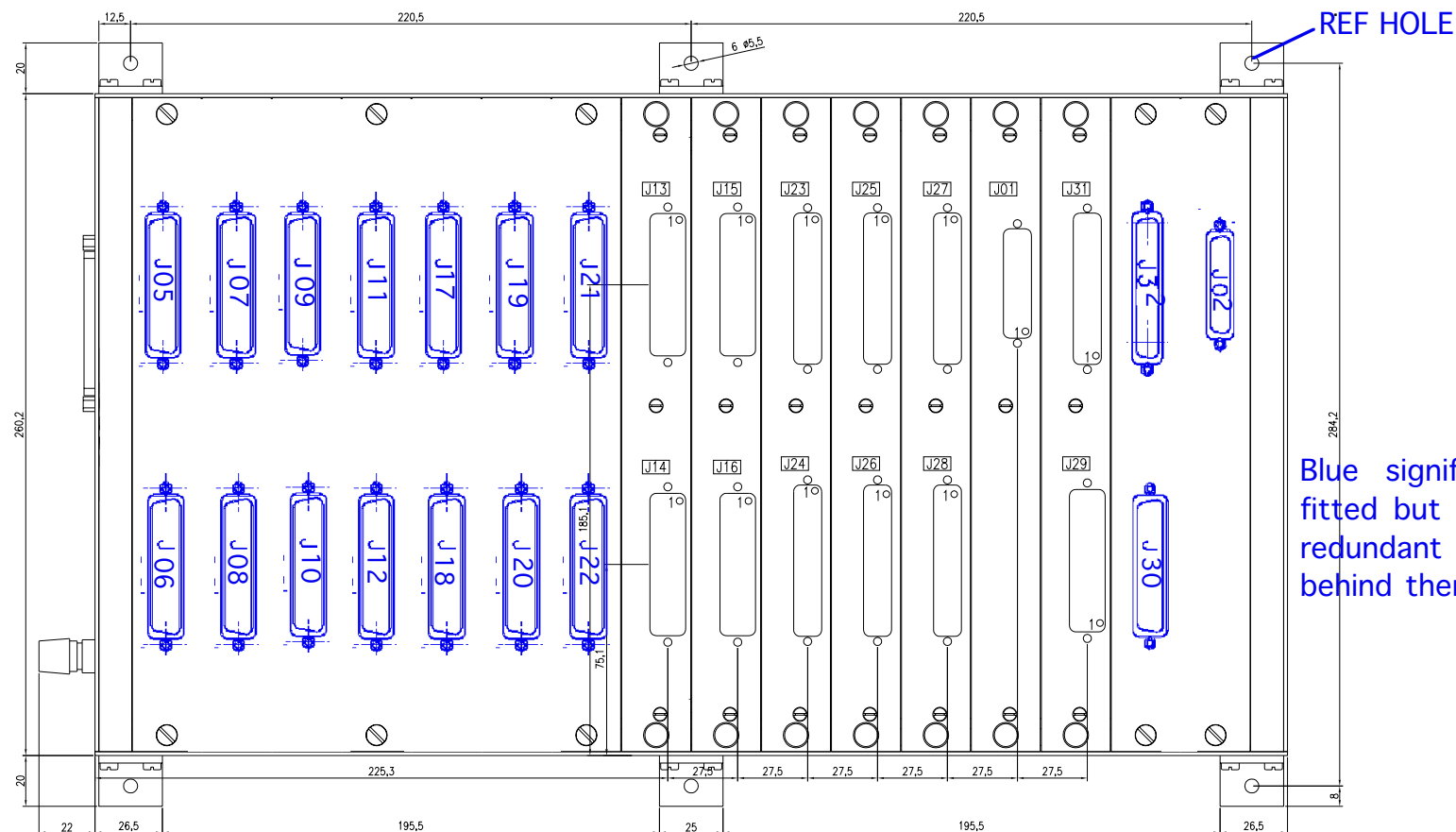
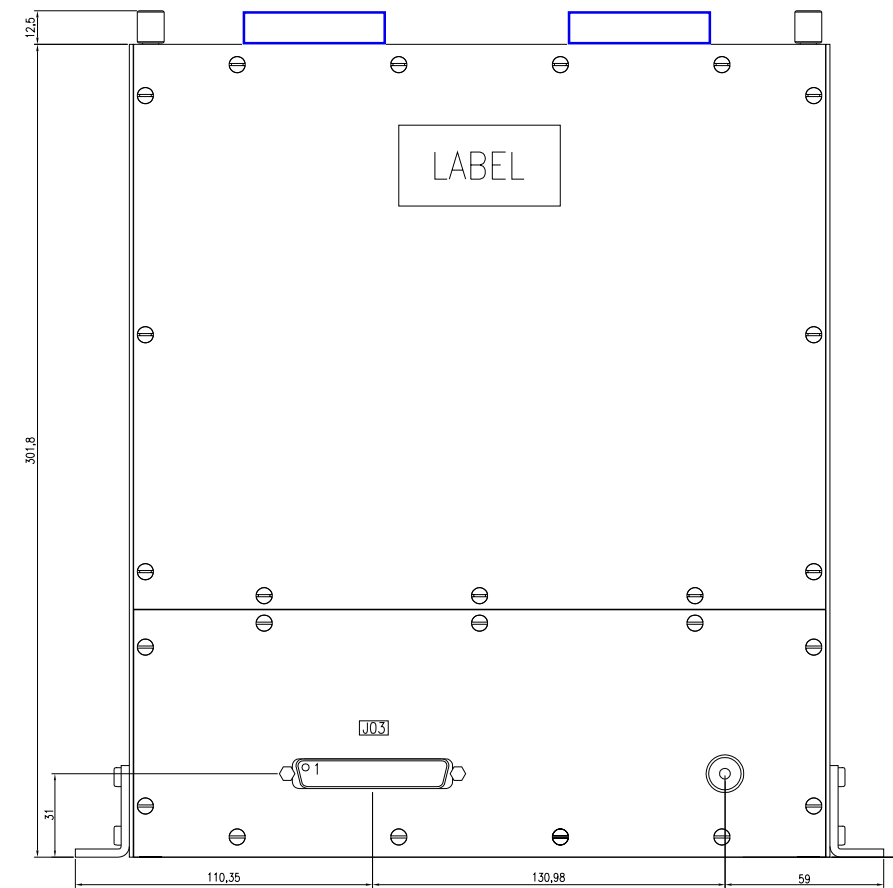
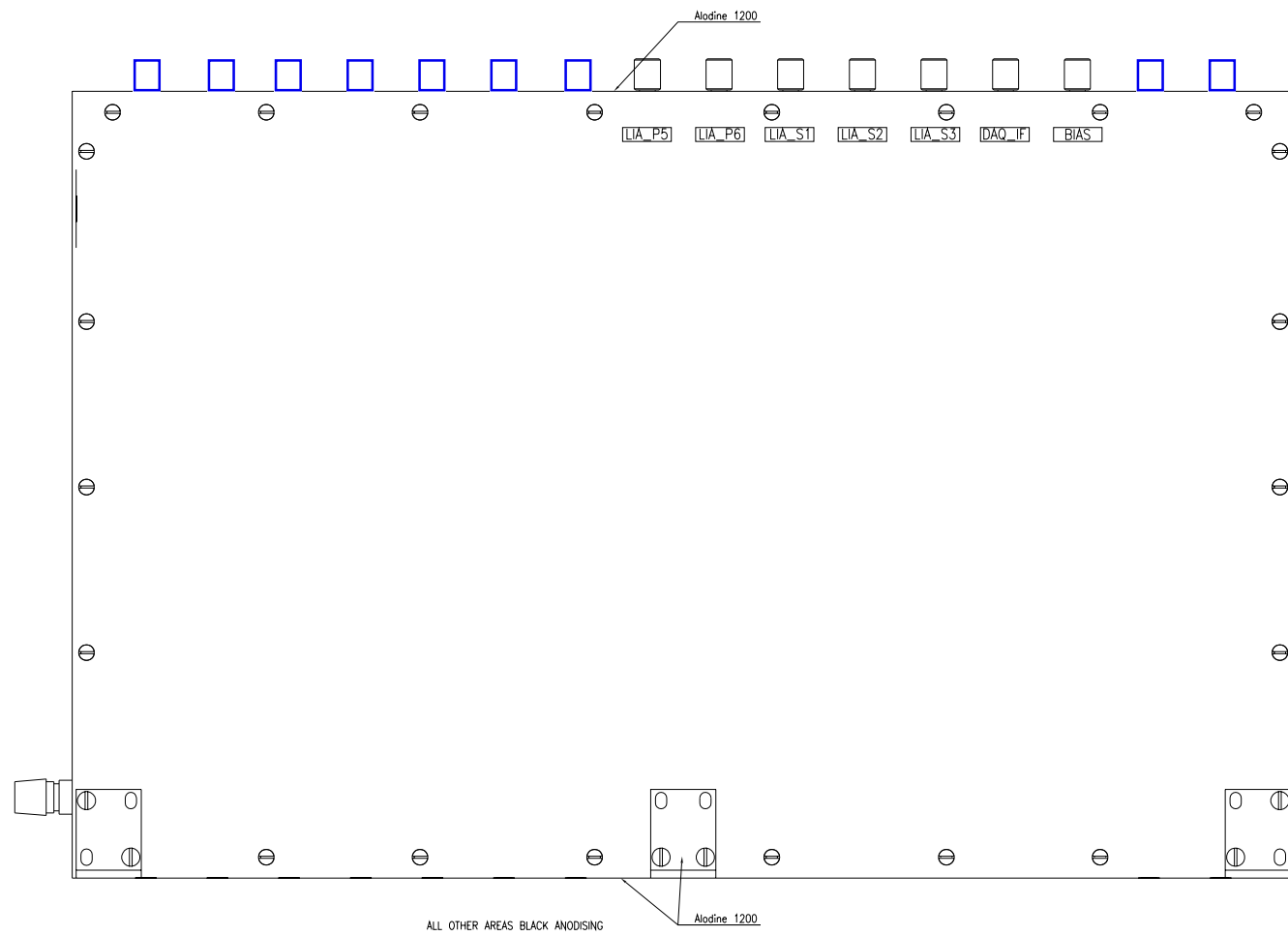

CONNECTORS					
IDENT	TYPE	FUNCTION	IDENT	TYPE	FUNCTION
J01	DBMA 25S	DAO_IF_M/DPU	J24	DCMA 37P	LIA_S_1/FPU
J03	DBMA 25P	DCU/PSU_M	J25	DCMA 37P	LIA_S_2/FPU
J13	DDMA 50P	LIA_P_5/FPU	J26	DCMA 37P	LIA_S_2/FPU
J14	DDMA 50P	LIA_P_5/FPU	J27	DCMA 37P	LIA_S_3/FPU
J15	DDMA 50P	LIA_P_6/FPU	J28	DCMA 37P	LIA_S_3/FPU
J16	DDMA 50P	LIA_P_6/FPU	J29	DDMA 78S	BIAS_M/FPU
J23	DCMA 37P	LIA_S_1/FPU	J31	DCMA 37S	BIAS_M/FPU

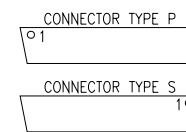

ONLY FOR QM1

CEA /SAP 91191 GIF/YVETTE Cedex	MATIERE : Alu 2017A	PROTECTION :
	TRAITEMENT : Alodine 1200	DESSINE : SREE DATE : 02/12/02 VERIFIE : VISA :
CE DOCUMENT EST LA PROPRITE DE LA SOCIETE C.E.A. ET NE PEUT ETRE REPRODUIT OU COMMUNIQUE SANS AUTORISATION ECRITE		
ECHELLE : 3/4	TOLERANCES GENERALES : ±0.2	Ro1,6
DESIGNATION ICD HS DCU/QM1	SRIR-MX-5101 000 A	0 A1



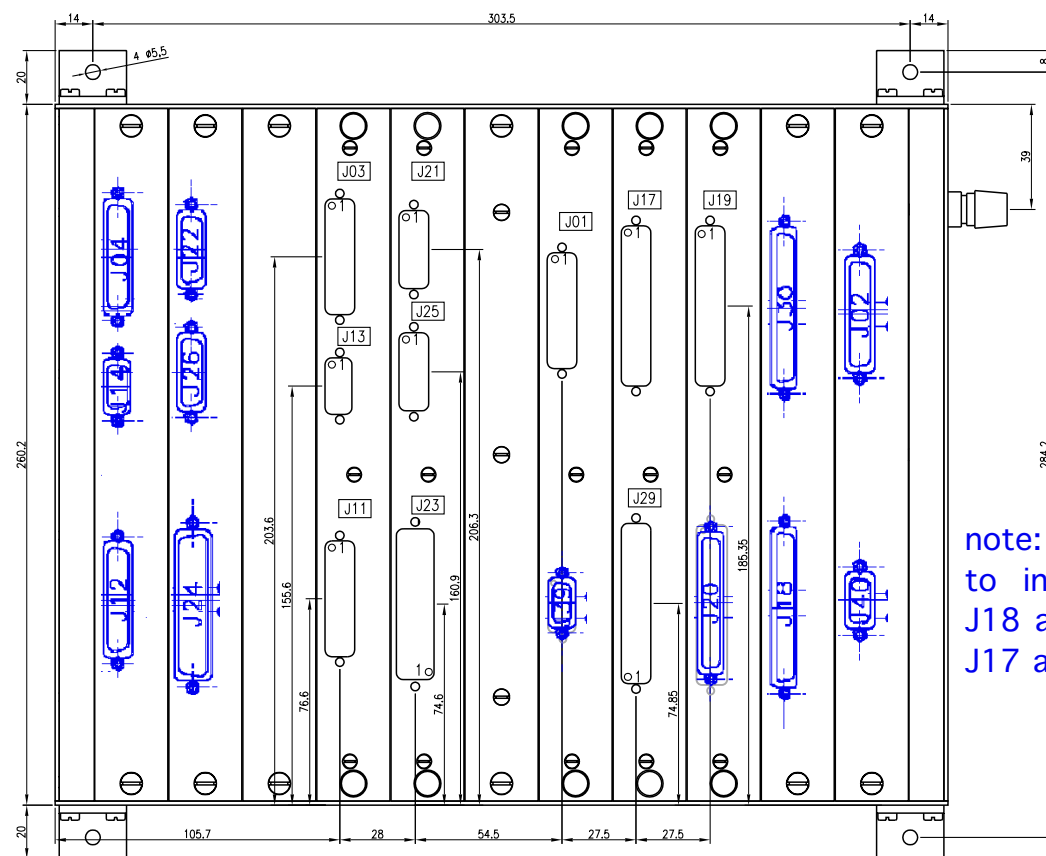
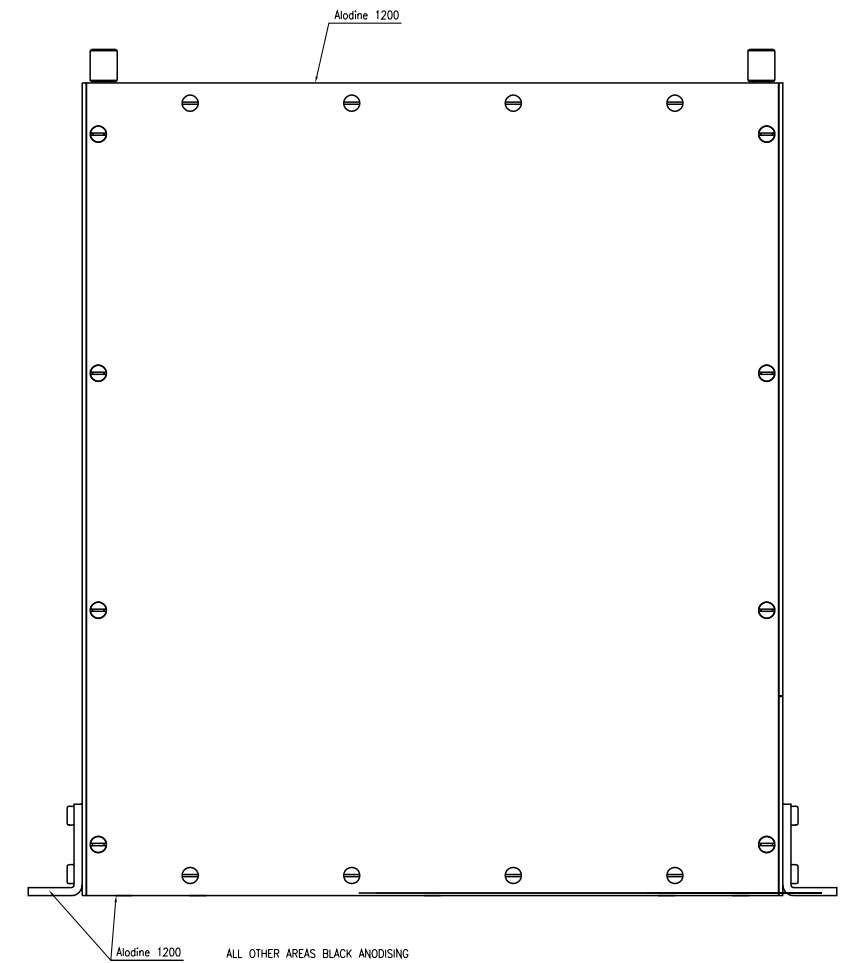
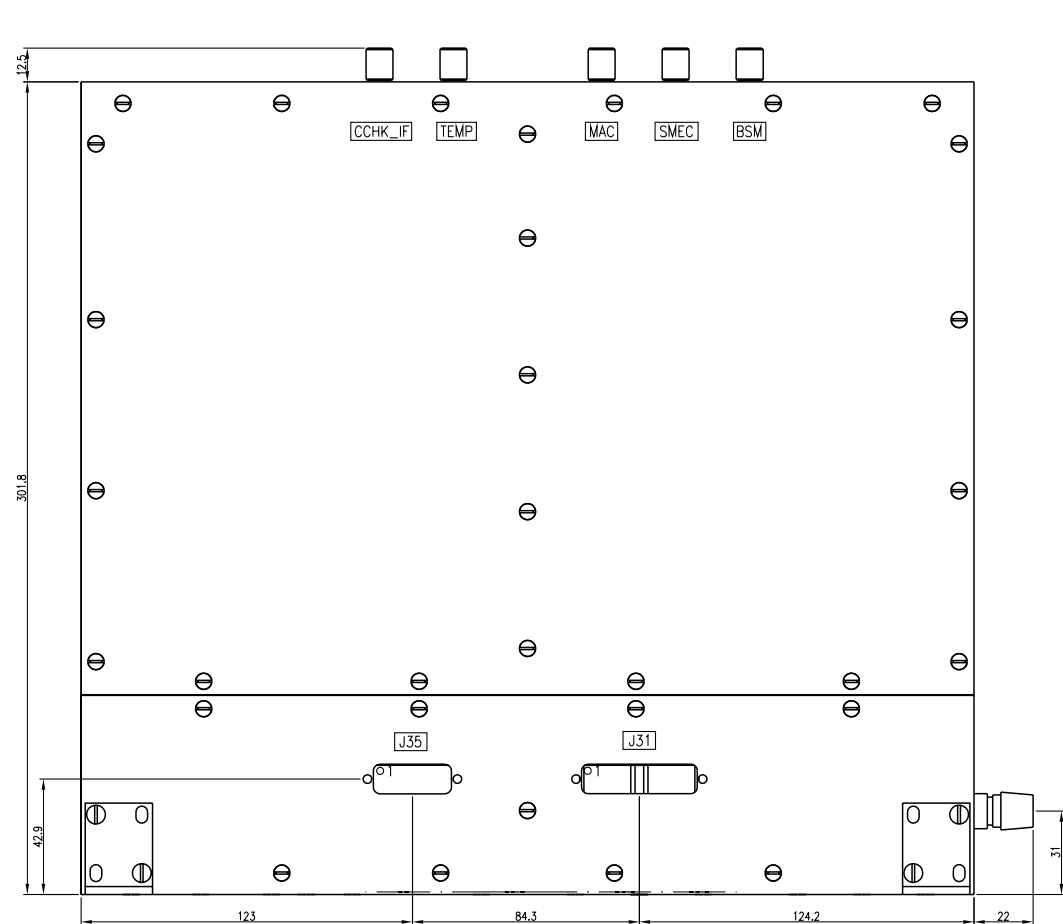
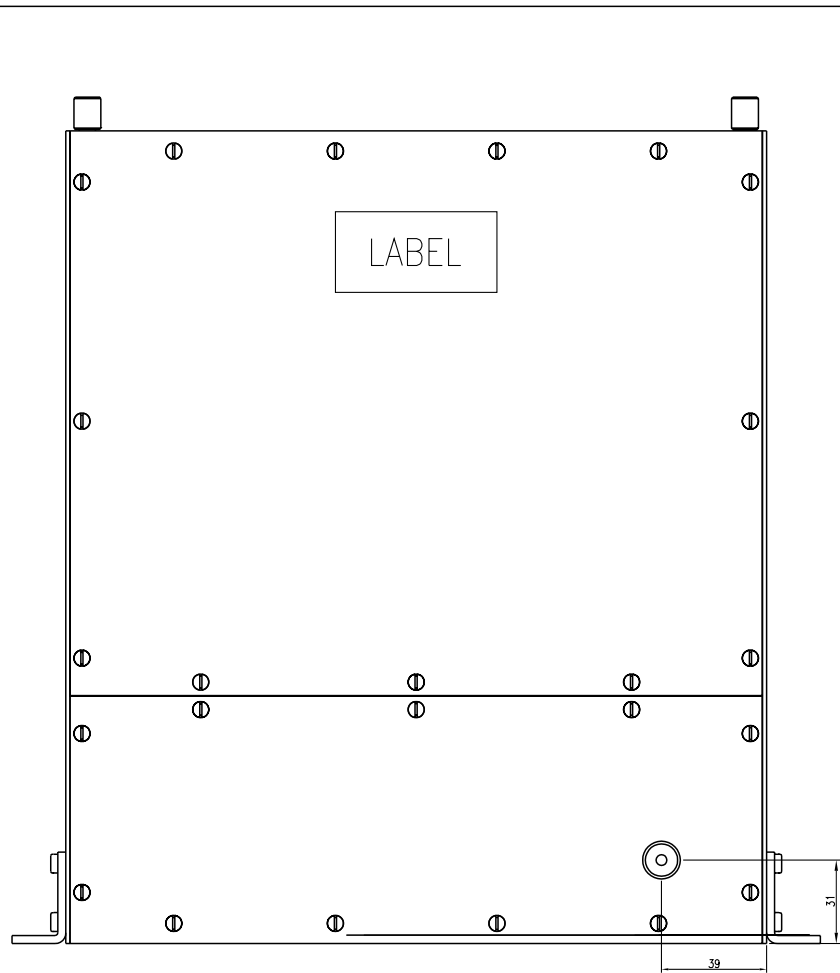

CONNECTORS					
IDENT	TYPE	FUNCTION	IDENT	TYPE	FUNCTION
J01	DBMA 25S	MAC/DPU	J21	DAMA 15S	TEMP/FPU-TS-1
J03	DBMA 25S	CCHK-IF/DPU	J23	DDMA 50S	TEMP/FPU-TS-2
J11	DBMA 25S	CCHK-IF/FPU-COOL-CAL	J25	DAMA 15S	TEMP/FPU-MEC-TS
J13	DEMA 9S	CCHK-IF/FPU-PH-STIM	J29	DCMA 37P	SMEC/FPU-SMECm-2
J17	DCMA 37S	SMEC/FPU-SMECm-1	J31	DBMA 25P	MCU/PSU
J19	DCMA 37S	BSM/FPU-BSM	J35	DAMA 15P	SCU/PSU

ONLY FOR QM1

Blue signifies connectors fitted but without redundant side electronics behind them.

note: do not intend to incorrectly transpose J18 and J30 just because J17 and J39 are swapped!

CEA /SAP 91191 GIF/YVETTE Cedex		MATIERE : Alu 2017A	PROTECTION :
TRAITEMENT : ALODINE 1200		DESSINE : SREE DATE : 08/09/03	VERIFIE : VISA :
CE DOCUMENT EST LA PROPRIETE DE LA SOCIETE C.E.A. ET NE PEUT ETRE REPRODUIT OU COMMUNIQUE SANS AUTORISATION ECRITE			
ECHELLE : 3/4	TOLERANCES GENERALES : ±0.2	Ro1.6	
DESIGNATION ICD HS FCU/QM1		SPIR-MX-5201 000 C	0 A1