



HERSCHEL / PLANCK

Cleanliness Requirements Specification

H-P-1-ASPI-SP-0035

Product Code : 000 000

Rédigé par/ Written by	Responsabilité-Service-Société Responsibility-Office -Company	Date	Signature
Muriel Giordanengo	cleanliness engineer	29/09/03	
Vérifié par/ Verified by			
M. Rossi	head of "AMT instrument" service	29/09/03	
P.Rideau	Herschel/Planck System Engineering Manager	3/10/03	
Approbation/ Approved			
Ch.Masse	Herschel/Planck PA Manager	02/10/03	
J.J.Juillet	Herschel/Planck Project Manager	3/10/03	

Data management : Christiane GIACOMETTI

Entité Emettrice : Alcatel Space - Cannes
(détentrice de l'original) :

CLEANLINESS REQUIREMENTS SPECIFICATION

REFERENCE : H-P-1-ASPI-SP-0035

DATE : 26-Sept-2003

ISSUE : 2.2

PAGE : 2/41

DISTRIBUTION / *DISTRIBUTION RECORD*

EXTERNAL DISTRIBUTION	For Information For Application For Approbation For Action For Acceptation	INTERNAL DISTRIBUTION	
ESA	For Information	HP team	
		P.Rideau	X
ASTRIUM	For Application	Y.Roche	X
		I.Bénilan	X
ALENIA	For Application	K.Hibberd	
		L.Trougnou	
CONTRAVES	For Application	P.Couzin	
		B.Collaudin	X
TICRA		Ph.Clavel	
		B.Marchand	
TECNOLOGICA		M.Cornut	X
		D.Montet	X
PROTOTECH		Y.Pocchiola	X
		P.Armand	X
CSL		J.B.Riti	X
		F.Schwartz	
OIP	For Application upon decision of Y. Pocchiola	Ch.Bainier	
		M.Pastorino	X
RF Suitcase Contractor		O.Fratacci	X
		Ph.Martin	X
APCO	For Information Upon decision of Ph. Schlosser	M. Giordanengo	X
		C. Masse	X
GMV			X
		CIIT Documentation	Orig.

CLEANLINESS REQUIREMENTS SPECIFICATION

REFERENCE : H-P-1-ASPI-SP-0035

DATE : 26-Sept-2003

ISSUE : 2.2

PAGE : 3/41

ENREGISTREMENT DES EVOLUTIONS / *CHANGE RECORD*

ISSUE	DATE	§ : DESCRIPTION DES EVOLUTIONS § : <i>CHANGE RECORD</i>	REDACTEUR <i>AUTHOR</i>
1.0	15/06/2001	First Issue for SRR	P. RIDEAU
2.0	28/06/2002	Second issue for PDR	H/P Engineering Team
2.1	29/11/2002	update according to PDR Rid n° 8210	H/P Engineering Team

ISSUE	DATE	§ : DESCRIPTION DES EVOLUTIONS § : <i>CHANGE RECORD</i>	REDACTEUR <i>AUTHOR</i>
2.2	26/09/2003	issue generated by DOORS-TREK update for closure of action n° 2 (SVM PA meeting n° 12 H-P-MI-AI-0216) annex 3 : updated	Muriel Giordanengo

List of requirements modified in, deleted in or new in issue 2.2

§ nb	Req. identifier	Change Status	Doc. issue	Reason of Change	Change Ref.
§4.3.3	[C-RS-055 a]	Modified in	2.2	answer to action n° 2 (SVM PA meeting H-P-MI-AI-0216)	

CLEANLINESS REQUIREMENTS SPECIFICATION

REFERENCE : H-P-1-ASPI-SP-0035

DATE : 26-Sept-2003

ISSUE : 2.2

PAGE : 4/41

TABLE OF CONTENTS

DISTRIBUTION / <i>DISTRIBUTION RECORD</i>	2
ENREGISTREMENT DES EVOLUTIONS / <i>CHANGE RECORD</i>	3
TABLE OF CONTENTS	4
LIST OF FIGURES AND TABLES	6
1. PURPOSE	7
1.1 SCOPE	7
1.2 APPLICABILITY	7
1.3 LIST OF SENSITIVE AND CRITICAL ELEMENTS	7
1.3.1 <i>Sensitive elements</i>	7
1.3.1.1 Herschel sensitive elements:	8
1.3.1.2 Planck sensitive elements:	9
1.3.2 <i>Critical elements</i>	9
2. REFERENCE AND APPLICABLE DOCUMENTS	10
2.1 APPLICABLE DOCUMENTS	10
2.2 REFERENCE DOCUMENTS	10
3. ACRONYMS	12
4. REQUIREMENTS	13
4.1 GENERAL REQUIREMENTS	13
4.2 GENERAL CLEANLINESS REQUIREMENTS	13
4.2.1 <i>Definition of acceptable levels</i>	13
4.2.2 <i>Particulate contamination</i>	14
4.2.3 <i>Molecular contamination</i>	15
4.2.4 <i>Hypotheses taken</i>	16
4.3 DESIGN CONSTRAINTS	17
4.3.1 <i>General design requirements</i>	17
4.3.2 <i>Design aspects for sensitive parts</i>	17
4.3.3 <i>Materials and process policy</i>	18
4.4 CLEANLINESS REQUIREMENTS FOR CRITICAL PHASES	18
4.4.1 <i>Manufacturing and process</i>	18
4.4.2 <i>Packaging, transport and storage</i>	18
4.4.3 <i>Integration, assembly</i>	19
4.4.4 <i>Tests</i>	20
4.4.5 <i>Launch preparation</i>	21
4.4.5.1 <i>Spacecraft/launcher installation</i>	21
4.4.5.2 <i>Spacecraft installation and fairing closure</i>	21
5. CLEANLINESS CONTROL	22
5.1 GENERAL	22
5.2 CONTROL METHOD	22

CLEANLINESS REQUIREMENTS SPECIFICATION

REFERENCE : H-P-1-ASPI-SP-0035

DATE : 26-Sept-2003

ISSUE : 2.2

PAGE : 5/41

5.2.1	Particulate contamination.....	22
5.2.2	Molecular contamination.....	23
5.3	NATURE AND FREQUENCY OF INSPECTIONS.....	23
5.4	NONCONFORMANCES, CORRECTIVE ACTIONS.....	23
5.5	PERIODIC CLEANLINESS REPORTING.....	24
6.	RESPONSIBILITIES.....	25
ANNEX 1A - ALLOCATIONS FOR PARTICULATE CONTAMINATION FOR HERSCHEL FPU.....		26
ANNEX 1B - ALLOCATIONS FOR PARTICULATE CONTAMINATION FOR HERSCHEL INSIDE CRYOSTAT.....		27
ANNEX 1C - ALLOCATIONS FOR PARTICULATE CONTAMINATION FOR HERSCHEL TELESCOPE...		28
ANNEX 1D - ALLOCATIONS FOR PARTICULATE CONTAMINATION FOR HERSCHEL SPACECRAFT		29
ANNEX 1E - ALLOCATIONS FOR PARTICULATE CONTAMINATION FOR PLANCK INSTRUMENTS (FPU).....		30
ANNEX 1F - ALLOCATIONS FOR PARTICULATE CONTAMINATION FOR PLANCK OPTICAL CAVITY		31
ANNEX 1G - ALLOCATIONS FOR PARTICULATE CONTAMINATION FOR PLANCK SPACECRAFT...		32
ANNEX 2A - ALLOCATIONS FOR MOLECULAR CONTAMINATION FOR HERSCHEL AND PLANCK INSTRUMENTS.....		33
ANNEX 2B - ALLOCATIONS FOR MOLECULAR CONTAMINATION ON TELESCOPES.....		34
ANNEX 2C - ALLOCATIONS FOR MOLECULAR CONTAMINATION FOR HERSCHEL AND PLANCK SPACECRAFT.....		36
ANNEX 3 - ENVIRONMENT CONTROL NATURE AND FREQUENCY OF INSPECTIONS.....		38
ANNEX 4 - DURATION AND TEMPERATURE OF THE BAKING PROCESSES.....		41

CLEANLINESS REQUIREMENTS SPECIFICATION

REFERENCE : H-P-1-ASPI-SP-0035

DATE : 26-Sept-2003

ISSUE : 2.2

PAGE : 6/41

LIST OF FIGURES AND TABLES

ERREUR! AUCUNE ENTRÉE DE TABLE D'ILLUSTRATION N'A ÉTÉ TROUVÉE.

CLEANLINESS REQUIREMENTS SPECIFICATION

REFERENCE : H-P-1-ASPI-SP-0035

DATE : 26-Sept-2003

ISSUE : 2.2

PAGE : 7/41

1. PURPOSE

1.1 SCOPE

This document defines the cleanliness requirements applicable to the Herschel and Planck satellite (except the optical elements of the experiments, the interfaces of which are covered by IID A and B), to:

- the sensitive parts of the spacecraft which if affected by contamination, can reduce the sensitivity and performance of the telescopes and sensors
- the critical parts of the spacecraft, which are sources for contamination.

NB: Sensitive and critical are used in respect to cleanliness.

Acceptable contamination levels are those which do not degrade the equipment performances over specified values for the duration of the nominal mission.

1.2 APPLICABILITY

This cleanliness requirements specification applies to Herschel/Planck program assuming ground life activities and a nominal mission.

The ground life activities include:

- design, manufacturing, assembly/integration and tests of sensitive elements and critical elements
- storage, packaging, transport, handling
- launch phase preparation.

The cleanliness requirements for the mission include:

- launch
- cryo-cover opening (on Herschel)
- contamination by internal PLM materials
- back scattering of spacecraft outgassing products
- back scattering of attitude thruster plumes
- particles redistribution
- micrometeorites.

1.3 LIST OF SENSITIVE AND CRITICAL ELEMENTS

1.3.1 *Sensitive elements*

Those elements, if affected by contamination can reduce the sensitivity and performances of the telescope and sensors.

CLEANLINESS REQUIREMENTS SPECIFICATION

REFERENCE : H-P-1-ASPI-SP-0035

DATE : 26-Sept-2003

ISSUE : 2.2

PAGE : 8/41

1.3.1.1 Herschel sensitive elements:

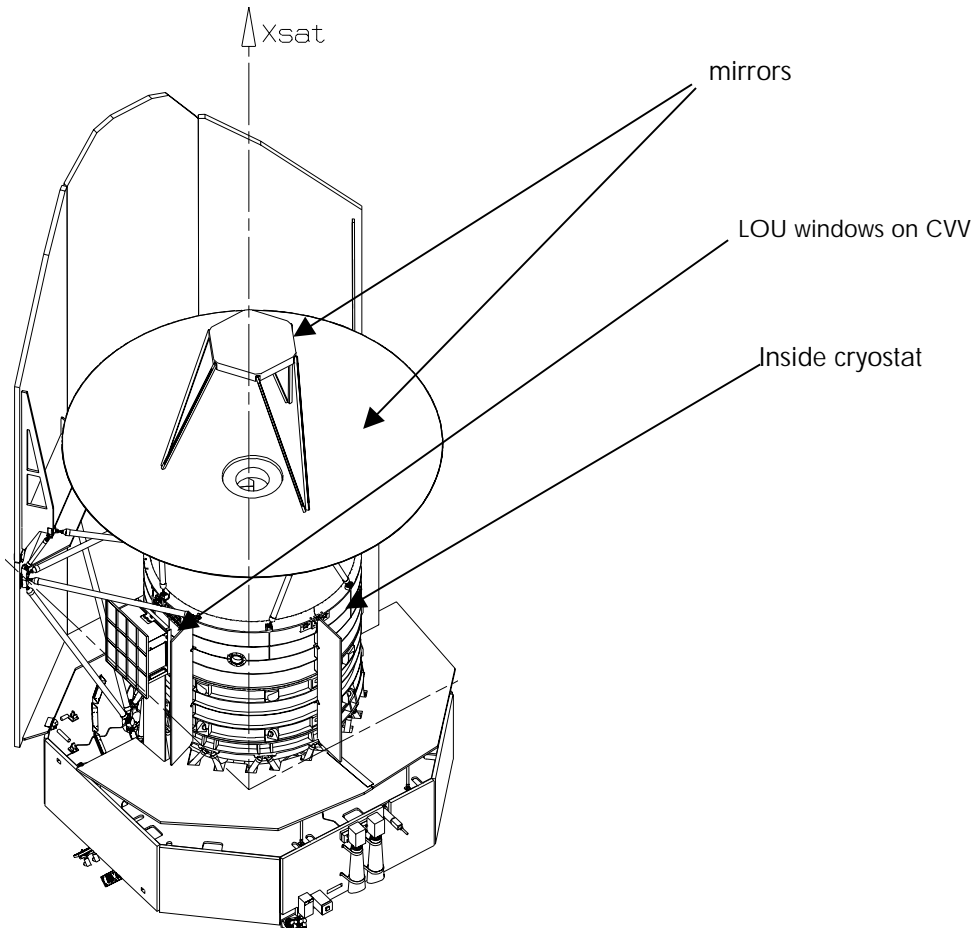

CLEANLINESS REQUIREMENTS SPECIFICATION

REFERENCE : H-P-1-ASPI-SP-0035

DATE : 26-Sept-2003

ISSUE : 2.2

PAGE : 9/41

1.3.1.2 Planck sensitive elements:

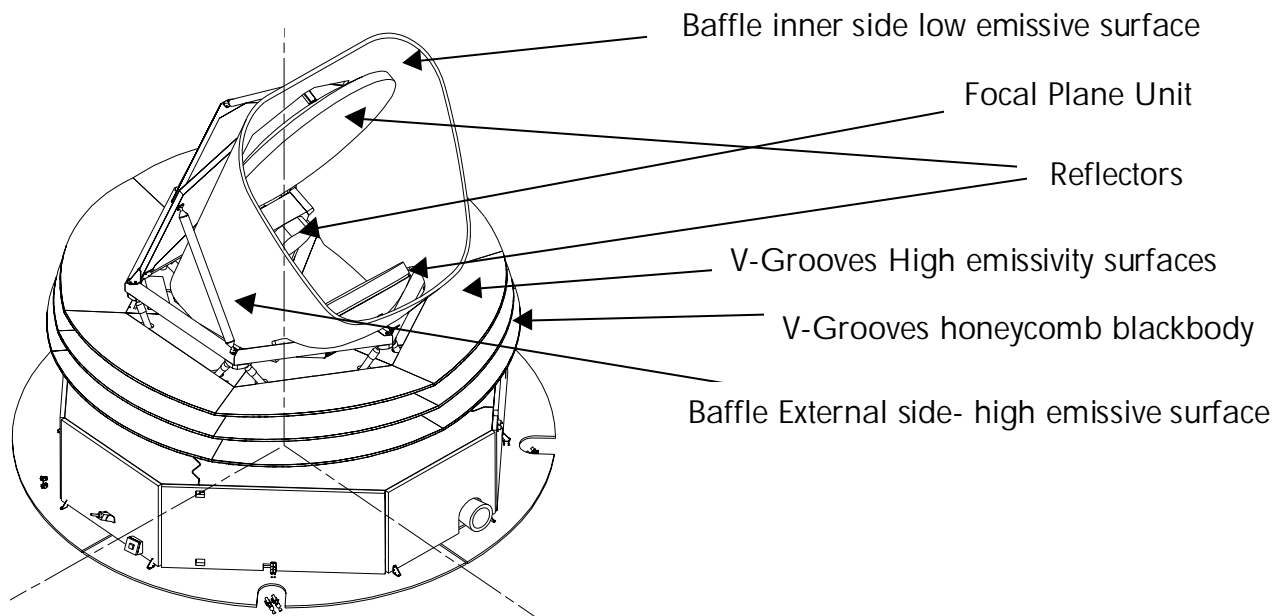

Additionally to the specific elements listed for Herschel and Planck, the following items are sensitive with regards to contamination :

- the star-trackers
- the solar panels.

These elements are sensitive but not critical as :

- the star trackers will be mostly protected during AIT
- the solar panels are cleanable surfaces.

1.3.2 Critical elements

They are the sources for contamination.

Although the whole satellite is a source of pollution, the main critical elements are:

- baffling system
- thermal control surface (MLI)
- coatings of surfaces, paint
- CFRP structures
- cryostat including cryo-cover and Helium system
- RCS exhaust gas.
- O rings on Herschel cryostat

CLEANLINESS REQUIREMENTS SPECIFICATION

REFERENCE : H-P-1-ASPI-SP-0035

DATE : 26-Sept-2003

ISSUE : 2.2

PAGE : 10/41

2. REFERENCE AND APPLICABLE DOCUMENTS

2.1 Applicable documents

AD1	FIRST/Planck Product Assurance and Safety Requirements SCI-PT-RS-04683
AD2	Product assurance requirement for Subcontractors H-P-1-ASPI-SP-0018
AD3	Herschel/Planck General Design and Interface Requirements H-P-1-ASPI-SP-0027
AD4	Herschel/Planck Environment and Tests Requirements H-P-1-ASPI-SP-0030
AD5	Quality assurance of ESA spacecraft and associated equipment ECSS Q 20a
AD6	Contamination and cleanliness control ECSS Q 70-01 draft
AD7	Preservation, storage, handling and transportation of ESA spacecraft and associated equipments ESA PSS 01-202
AD8	Quality assurance of test houses for ESA satellite and associated equipments ESA PSS 01-203
AD9	Particulate contamination control in clean room by particule fall out (PFO) measurements ESA PSS 01-204
AD10	Material and process control and procurement for ESA spacecraft and associated equipment ECSS Q-70.a
AD11	A thermal vacuum test for the screening of space materials ESA PSS 01-702
AD12	A thermal cycling test for the screening of space materials and processes ECSS Q-70-04.a
AD13	The detection of organic contamination of surfaces by infrared spectroscopy ESA PSS 01-705
AD14	Measurement of thermo-optical properties of thermal control materials ESA PSS 01-709

2.2 Reference documents

RD1	Federal standard n° 209 B - clean room and workstation requirement controlled environment.
RD2	ASTM F 50: continuous sizing and counting of airborne particles in dust controlled areas using instruments based on light scattering principle.
RD3	Doc. n° MIL-STD-1246A: product cleanliness assurance levels and contamination control program.
RD4	ASTM-F 24: measuring and counting particulate contamination on surfaces.

CLEANLINESS REQUIREMENTS SPECIFICATION

REFERENCE : H-P-1-ASPI-SP-0035

DATE : 26-Sept-2003

ISSUE : 2.2

PAGE : 11/41

RD5	End of life cleanliness Needs.H-P-1-ASPI-TN-0197 Issue 1
RD6	Planck Cleanliness Control PlanH-P-3-ASPI-PL-0253 Issue 1
RD7	Herschel Cleanliness Control PlanH-P-2-ASED-PL-0023 issue 1/0
RD8	Cleanliness team ReportH-P-1-API-RP-0314 Issue 1/0

CLEANLINESS REQUIREMENTS SPECIFICATION

REFERENCE : H-P-1-ASPI-SP-0035

DATE : 26-Sept-2003

ISSUE : 2.2

PAGE : 12/41

3. ACRONYMS

AD	Applicable Document
AIT	Assembly, Integration and Test
AIV	Assembly, Integration and Verification
AOCS	Attitude and Orbit Control System
BRDF	Bidirectional Reflectance Distribution Function
EEE	Electric, Electromecanic and Electronic
EOL	End Of Life
GSE	Ground Support Equipment
IID	Instrument Interface Document
MLI	MultiLayer Insulation
PDR	Preliminary Design Review
PLM	PayLoad Module
PSF	Point Spread Function (image quality)
RCS	Reaction Control Subsystem
RF	Radio Frequency
SVM	Service Module
TBC	To Be Confirmed

4. REQUIREMENTS

4.1 GENERAL REQUIREMENTS

The performance of the Payloads being directly degraded by contamination, the contaminant aspects are important for Herschel and Planck until the end of mission. These requirements shall be implemented as early as possible in the design phase for sensitive and critical elements.

They shall be strictly enforced to minimize degradation of both on-ground and in orbit performances of above elements caused by any pollution whatever (cf. Doc. n° AD 6).

The sensitive elements are influenced by:

- diffusion induced by debris, particles or molecular situated in the optical paths, as deposited on some surfaces or flying along with the spacecraft
- alteration of the telescope transmission by molecular contamination and, particulate contamination (obscuration)
- alteration of reflective and anti-reflective coatings properties by molecular contamination or chemical aggression
- alteration of the reflective coating properties by molecular contamination or chemical aggression
- contamination due to critical elements
- redistribution of particles during environmental tests or handling operations and during launch.

The effects of contamination, the sources of contamination and the elements sensitive to external sources are listed in Table 4.1-1.

The critical performances which might be degraded by contaminants are:

- straylight (scattering and self emission)
- transmission
- image quality/RF gain
- emittance of thermal and optical surfaces
- solar absorptance

4.2 GENERAL CLEANLINESS REQUIREMENTS

4.2.1 Definition of acceptable levels

The main drivers for the cleanliness analysis are firstly the contamination of optical surfaces (i.e. telescopes and instruments) ; and secondly the contamination of thermal surfaces (i.e. V.grooves, thermal shields, cryostat internal surfaces)

In order to quantify the cleanliness levels at different stages of the development, it has been:

- defined the maximal degradations of the performances at end of life
- estimated the contamination occurred from the launch to the end of life
- apportioned of the maximum allowable contamination during the development up till launch.

CLEANLINESS REQUIREMENTS SPECIFICATION

REFERENCE : H-P-1-ASPI-SP-0035

DATE : 26-Sept-2003

ISSUE : 2.2

PAGE : 14/41

- The assessment which maximum contamination (particulate and molecular) levels are acceptable at end of life on both spacecrafts is presented and justified in RD5. It covers system and instruments needs.

In order not to have too much influence coming from the outside part of the satellite, maximum allowable contamination levels at various stages of Herschel/Planck program have been established. This has been performed during «cleanliness working groups» driven by ESA, and where industrials and experiments were represented.

- The acceptable levels at different stages of the development are tabulated in Annex 1 for particle contamination and in Annex 2 for molecular contamination.
- The working group established that the particulate contamination is driving a part of the final performance of the experiments, in particular in the case of HFI on Planck. So, the working group advised that any low-cost precaution having a positive impact on particulate cleanliness should be taken.
- From the above mentioned budgets, requirements for environments, facilities, handling, protections, etc. will be derived at each level.

The assumptions for the definition of the cleanliness end of life needs (particles and molecules) are based on losses in the following performances:

- Transmission/emissivity of optical components
- straylight (BRDF)
- image quality (BRDF).
- Thermal performances of main shields (emissivity / reflectivity)

This is covered in the End of life Cleanliness Needs technical note

In a general way critical elements and sensitive elements have to be on the same level of cleanliness.

The Cleanliness Control Plans [RD6] and [RD7] present the way the cleanliness is monitored and mastered during spacecrafts AIT

Moreover removal of dust can be locally performed by blowing + vacuum extraction if necessary and only with common agreement with ESA and the prime.

4.2.2 Particulate contamination

Herschel / Planck common features :

- Dust particles have a statistical distribution. The particle size distribution is considered in accordance with the standard : MIL-STD-1246-C. This is justified by measurement performed in Alcatel (cf RD5)
- One of the main contributors for the particulate contamination is the launch phase . This contributor is estimated to 1000 ppm (cf RD8)
- For thermal impact evaluation the dust emissivity is considered to be 0.8 for particles being on low emissivity surfaces, and 0.2 on high emissivity surfaces. This conservative approach is followed to derive maximum end of life allowable particulate contamination on thermal parts(RD5).

Particulate contamination on Herschel

- The following tables present the end of life needs on Herschel sensitive parts:

(**) not yet accepted by industry

the requirements at the several stages of Herschel Spacecraft are defined in Annexes 1A to E

CLEANLINESS REQUIREMENTS SPECIFICATION

REFERENCE : H-P-1-ASPI-SP-0035

DATE : 26-Sept-2003

ISSUE : 2.2

PAGE : 15/41

EOL cleanliness level needs	Particulate (ppm)
Telescope M1	4300
Telescope M2	4650
PACS FPU (outside)	1500
SPIRE FPU (outside)	No requirement yet
HIFI FPU (outside)	1200
HIFI LOU CVV windows (**)	1200
LOU inside (**)	300

Particulate contamination on Planck

- The driving parameter on Planck is the straylight induced by reflector scattering.
- From a Straylight point of view, 5000ppm on telescope and instrument is the upper acceptable limit for the higher frequency channels of Planck.
- However we have to notice that the radiated background due to particulate contamination of reflectors is the most limiting parameter for HFI performances. It is why the reduction of particulate contamination should be a permanent goal during the Planck development programme.
- From a thermal point of view the main drivers are the increase of emissivity of thermal shields (V.grooves and external layers of MLI) and the decrease of emissivity of radiative surfaces (external side of the baffle, groove 3 extension).
- The following tables present the end of life needs on Planck sensitive parts:

EOL cleanliness level needs	Particulate (ppm)
Focal Plane Unit	5000
Telescope PR	5000
Telescope PR	5000
Groove 1 (low emissivity surfaces)	10 000
Groove 2	10 000
Groove 3	10 000
Groove 3 and baffle external side (high emissivity surfaces)	15 000
Baffle (internal side)	10 000

4.2.3 Molecular contamination

Herschel / Planck common features :

- The on-ground contamination comes from environment, facilities, people, GSE, etc...
- The main in-flight contamination sources will be :
 - water ice deposition on cold optical and cold thermal surfaces from materials out-gassing
 - water-ice and ammonia ice (NH₃) deposition on cold optical and cold thermal surfaces from back-scattering of propulsion exhaust gas.
- The main effect of molecular contamination will be an increase of the surfaces emissivity, inducing:
 - from an optical point of view, transmission losses and an increase of the radiated background
 - from a thermal point of view, an increase of thermal coupling (loss of thermal shield efficiency).

Herschel molecular contamination :

CLEANLINESS REQUIREMENTS SPECIFICATION

REFERENCE : H-P-1-ASPI-SP-0035

DATE : 26-Sept-2003

ISSUE : 2.2

PAGE : 16/41

- The following table present the end of life needs in terms of molecular contamination on Herschel sensitive parts. Between the system and the instruments needs, only driving ones are considered:

EOL cleanliness level needs	Molecular (g/cm ²)		
	H ₂ O	NH ₃	On ground contaminants
Telescope M1	1.5 10 ⁻⁶	10 ⁻⁶	10 ⁻⁶
Telescope M2	1.5 10 ⁻⁶	10 ⁻⁶	10 ⁻⁶
PACS FPU (outside)	6 10 ⁻⁶		
SPIRE FPU (outside)	10 ⁻⁴		
HIFI FPU (outside)	6 10 ⁻⁶		
HIFI LOU CVV windows (**)	8.5 10 ⁻⁶		
LOU inside (**)	4 10 ⁻⁶		

(**) not yet accepted by industry

Planck molecular contamination

- The following table present the end of life needs in terms of molecular contamination on Planck sensitive parts. Between the system and the instruments needs, only driving ones are considered:

EOL cleanliness level needs	Molecular (g/cm ²)		
	H ₂ O	NH ₃	On ground contaminants
Focal Plane Unit(*)	7 10 ⁻⁶		
Telescope PR	4 10 ⁻⁶		
Telescope PR	4 10 ⁻⁶		
Groove 1 (low emissivity surfaces)	10 10 ⁻⁵	1.4 10 ⁻⁵	13 10 ⁻⁵
Groove 2	15 10 ⁻⁵	1.4 10 ⁻⁵	13 10 ⁻⁵
Groove 3	10 10 ⁻⁵	10 10 ⁻⁵	13 10 ⁻⁵
Groove 3 and baffle external side (high emissivity surfaces)	3 10 ⁻⁵	1.5 10 ⁻⁵	3 10 ⁻⁵
Baffle (internal side)	20 10 ⁻⁵	5.6 10 ⁻⁵	1 10 ⁻⁵

4.2.4 Hypotheses taken

- 1 vacuum test (without any vacuum breaking) contaminates of: 25 ppm 1.10⁻⁹ g/cm²/day
- 1 day in Class 100,000 is equivalent to: 225 ppm 3.10⁻⁹ g/cm²
- 1 day in Class 10,000 is equivalent to: 60 ppm 3.10⁻⁹ g/cm²
- 1 day in Class 1000 is equivalent to: 12 ppm 2.10⁻⁹ g/cm²
- 1 day in Class 100 is equivalent to: 1.5 ppm 1.5.10⁻⁹ g/cm²
- Contamination during transport: 25 ppm 10⁻⁹ g/cm²/day
- Efficiency of protection and MLI cleanshell sealed with Kapton:
 - particulate contamination: 100 %
 - molecular contamination: 100 % except for vibration particulate contamination: 10 ppm.

CLEANLINESS REQUIREMENTS SPECIFICATION

REFERENCE : H-P-1-ASPI-SP-0035

DATE : 26-Sept-2003

ISSUE : 2.2

PAGE : 17/41

4.3 DESIGN CONSTRAINTS

4.3.1 General design requirements

As the Herschel/Planck spacecraft is seen to be sensitive to contamination, sufficient attention shall be paid to the cleanliness aspects in the design in order to permit the achievement and maintenance of the specified cleanliness requirements.

To assure the most effective cleanliness control, the designers shall take already early into account the following topics:

Reference C-RS-005

- Contaminant sources shall be as far away as possible from sensitive parts.

*

Reference C-RS-010

- materials which do not induce release of particles shall be used

*

Reference C-RS-015

- position of venting holes in the spacecraft shall be optimized.

*

Reference C-RS-020

- permanent shields, temporary covers or hoods, for protection during critical contamination phases shall be used

*

Reference C-RS-025

- Consideration shall be given to cleanability as a design feature of parts, i.e. the possibility of accidental contamination shall be taken into account.

*

Reference C-RS-030

- The choice of manufacturing sequences, techniques and processes shall be governed by considerations concerning compatibility with desired cleanliness levels, unless the part can readily be cleaned afterwards.

*

4.3.2 Design aspects for sensitive parts

Reference C-RS-035

- The volumes enclosing the optical path shall be as far as possible closed by a dust-proof separation (filter, membrane, ...).

CLEANLINESS REQUIREMENTS SPECIFICATION

REFERENCE : H-P-1-ASPI-SP-0035

DATE : 26-Sept-2003

ISSUE : 2.2

PAGE : 18/41

*

Reference C-RS-040

- The optics and, also parts or units on the same cleanliness level as the optics (whenever possible), have to be covered by protective covers.

*

Reference C-RS-045

- For the telescopes and the thermal shields a place shall be foreseen to set the contamination samples.

*

Reference C-RS-050

- Contamination samples shall also be foreseen on the Herschel cryostat at the level of the HIFI LOU windows.

*

4.3.3 Materials and process policy

(Cf. Docs. n° AD 10 to 14).

Reference C-RS-055 a

For normal applications, the outgassing criteria are TML < 1% and CVCM < 0.1%.

For optical instruments of Herschel and Planck these values become TML < 0.1% and CVCM < 0.01%.

The hardware non compliant with the preceding requirements shall be submitted to a bake-out.

The duration and temperature of this baking process are defined in Annex 4 (a baking process is an accelerated outgassing by temperature increase).

*

4.4 CLEANLINESS REQUIREMENTS FOR CRITICAL PHASES

(Cf. Doc. n° AD 06)

4.4.1 Manufacturing and process

Reference C-RS-060

As soon as the manufacturing cycle does no more permit the cleaning of the parts, the cleanliness class of the cleanroom must be defined for each step in such a way to guarantee the required cleanliness level after completion of manufacturing assembly. Sensitive elements shall be as far as possible protected by cover.

*

4.4.2 Packaging, transport and storage

(Cf. Doc n° AD 05, Chapter: "Handling, storage, preservation, ..." and AD 07).

CLEANLINESS REQUIREMENTS SPECIFICATION

REFERENCE : H-P-1-ASPI-SP-0035

DATE : 26-Sept-2003

ISSUE : 2.2

PAGE : 19/41

-
- Storage

Reference C-RS-065

- The sensitive optical elements shall be protected at all time. The cleanliness requirement for the out-of-container storage areas shall be those defined per § 3.4.3. for integration areas.

*

- Packaging

Reference C-RS-0070

- All sensitive optical elements shall be packed with special protective covers against shock and under inert atmosphere.

*

- Transport

Reference C-RS-075

- The shipping containers shall be so designed that their inner walls are made of debris-free, dust-free material, easily cleanable with usual solvent (i.e. Isopropyl alcohol, Freon, Acetone, ...).

*

Reference C-RS-0080

- A dry, inert atmosphere shall prevail inside the container and shall remain so, even in slight depressure events.

*

Reference C-RS-0085

- The containers (i.e. essentially the long distance shipping containers) inner walls shall accommodate for emplacement of reference contamination samples near the sensitive elements.

*

Reference C-RS-090

- The containers inner walls shall be checked for molecular pollution after every shipment/transport.

*

4.4.3 Integration, assembly

Reference C-RS-095

When the sensitive optical elements are protected, the cleanliness class of integration areas shall be conform to the Class 100 000 (or better if necessary) defined in the standard Federal n° 209 B with:

- temperature: 22° C ± 3° C (except in storage period)
- relative humidity: 55 % ± 10 %.

*

CLEANLINESS REQUIREMENTS SPECIFICATION

REFERENCE : H-P-1-ASPI-SP-0035

DATE : 26-Sept-2003

ISSUE : 2.2

PAGE : 20/41

Reference C-RS-100

When the sensitive optical elements are not protected, the cleanliness class of the integration area shall be compliant with the requirements of the Annexes 1 and 2.

*

Reference C-RS-105

Any humidity condensation on Herschel cryostat windows (HIFI LOU windows) shall be avoided by specific design (sufficiently high temperature) or by flushing with dry nitrogen.

*

4.4.4 Tests

(Cf. Doc. n° AD 08).

Reference C-RS-110

The test and handling facilities and devices shall be cleaned beforehand by non contaminating processes.

*

Reference C-RS-115

In particular, all test and handling facilities/devices with lubricated mechanisms (trolleys, hoisting blocks, shakers, etc...) shall be so capped/covered as to preclude transfer of heavy molecules.

*

Reference C-RS-120

Before and after tests, the hardwares shall be checked for molecular and particulate contamination (see for example Annex 3).

*

Reference C-RS-125

The cleanliness class of test areas shall be the same as for integration areas (see § 3.4.3.), or better if necessary.

*

Specific environment test (thermal vacuum, temperature)

Reference C-RS-130

The test chambers shall be cleaned beforehand by non contaminating processes.

*

Reference C-RS-135

The cleanliness of the test chambers shall be checked before test through the blank test of the facility.

*

CLEANLINESS REQUIREMENTS SPECIFICATION

REFERENCE : H-P-1-ASPI-SP-0035

DATE : 26-Sept-2003

ISSUE : 2.2

PAGE : 21/41

Reference **C-RS-140**

Reference pollution samples shall be provided on the test specimen, near the sensitive surfaces.

*

Reference **C-RS-145**

The reference samples shall be checked for molecular contamination after tests.

*

Reference **C-RS-150**

Specific cold traps will be implemented in any vacuum chamber during cryogenic tests.

*

Reference **C-RS-155**

In order to avoid any risk of contamination, the sensitive elements shall be, as far as possible, heated for the return to ambient conditions.

*

4.4.5 Launch preparation

Final launch preparation phase consist of two steps:

- spacecraft erection atop launch vehicle
- spacecraft installation and fairing closure.

4.4.5.1 Spacecraft/launcher installation

Spacecraft is mated atop launch vehicle in Class 100 000.

Reference **C-RS-160**

All optical surfaces out of cryostat shall be capped/covered.

*

4.4.5.2 Spacecraft installation and fairing closure

Reference **C-RS-165**

The optical surfaces protective covers shall be removed before the fairing is closed.

*

Upon fairing closure, fairings interior is ventilated up till launch, with air of cleanliness class and climatic conditions as required in ARIANE manual.

CLEANLINESS REQUIREMENTS SPECIFICATION

REFERENCE : H-P-1-ASPI-SP-0035

DATE : 26-Sept-2003

ISSUE : 2.2

PAGE : 22/41

5. CLEANLINESS CONTROL

5.1 GENERAL

Cleanliness inspections in manufacturing, assembly, integration and test are under responsibility of the quality department of each Cocontractor.

Reference C-RS-170

A cleanliness control plan shall define methods, responsibilities and shall identify procedures involved in the achievement and maintenance of the cleanliness levels.

*

5.2 CONTROL METHOD

Reference C-RS-175

The requirements shall be verified on reference samples placed at representative locations.

*

Reference C-RS-180

Each sensitive element shall be ascribed a pair of particulate and molecular contamination reference samples, one for periodical checks, the other one cumulating the pollution until final measure.

*

5.2.1 Particulate contamination

Reference C-RS-185

Concentration and sizes of the dust particles contained in the atmosphere of manufacturing, integration and test rooms which must meet the cleanliness requirements as per § 2.4. can be measured by the following methods:

- counting the particles in the atmosphere
 - The particles in the clean areas atmosphere shall be counted using a particle counter functioning on a light diffusion.
 - Counting the particles deposited on the surfaces
 - Two methods are acceptable:
 - the indirect method which consist of the counting with help of a microscope the dust grains of different sizes
 - the direct method which consists of the use of an integrating particles fall-out photometer which gives direct readings of the obscuration factor according to Doc. n° ESA PSS 01-204.
-

*

CLEANLINESS REQUIREMENTS SPECIFICATION

REFERENCE : H-P-1-ASPI-SP-0035

DATE : 26-Sept-2003

ISSUE : 2.2

PAGE : 23/41

5.2.2 Molecular contamination

Molecular contamination control for the sensitive parts (inspection of pollution samples) as well as for the manufacturing and AIT rooms shall meet the requirements as per § 2.4

Reference C-RS-190

Such control shall utilise the infrared spectral analysis method mentioned in Doc. n° AD 13; i.e. it shall:

- either analyse the deposit over the pollution samples located within the clean room nearby the sensitive elements to be pollution controlled
- or analyse swabs after wiping a determined surface area using a lens paper or alternatively analyse the reference samples.

*

Reference C-RS-195

Location of the molecular contamination samples relative to sensitive elements and to environment shall to be specified in the cleanliness control plan.

*

5.3 NATURE AND FREQUENCY OF INSPECTIONS

Reference C-RS-200

The nature and frequency of the inspections shall be such as the level of cleanliness of the hardware is in conformance with this specification (see for example Annex 3).

*

Reference C-RS-205

Systematically all areas classified in terms of molecular and particulate contamination shall be inspected for cleanliness before initiating or after completing any activity.

*

5.4 NONCONFORMANCES, CORRECTIVE ACTIONS

(Cf. Doc. n° AD 05 Chapter : "Nonconformance").

Reference C-RS-205

It is the purpose of the inspections and checks mentioned above to identify as applicable, the polluted surface, the polluting agent origin (i.e. on-board unit or GSE devices).

*

Reference C-RS-210

The treatment of associated nonconformances shall follow the procedure defined in the product assurance specification.

*

CLEANLINESS REQUIREMENTS SPECIFICATION

REFERENCE : H-P-1-ASPI-SP-0035

DATE : 26-Sept-2003

ISSUE : 2.2

PAGE : 24/41

Reference C-RS-215

The corrective actions shall involve:

- as applicable, decontamination of the sensitive surfaces
 - changes to the pollution sources
 - changes to the inspection procedures.
-

*

5.5 PERIODIC CLEANLINESS REPORTING

Reference C-RS-220

For each sensitive element (defined in Chapter 1.3.1), it is required to report in the monthly progress report (chapter product assurance) the cleanliness measurements and the associated step of the flow chart.

*

CLEANLINESS REQUIREMENTS SPECIFICATION

REFERENCE : H-P-1-ASPI-SP-0035

DATE : 26-Sept-2003

ISSUE : 2.2

PAGE : 25/41

6. RESPONSIBILITIES

Reference C-RS-225

The Contractor shall assure that the requirements are fulfilled via the implementation of the cleanliness control plan for the applicable phases of the program.

*

In case of conflicts because of the implementation of the cleanliness requirements and other requirements as e.g. mission requirements, design requirements, test requirements, ALCATEL and ESA will take the final decision.

CLEANLINESS REQUIREMENTS SPECIFICATION

REFERENCE : H-P-1-ASPI-SP-0035

DATE : 26-Sept-2003

ISSUE : 2.2

PAGE : 26/41

ANNEX 1A – ALLOCATIONS FOR PARTICULATE CONTAMINATION FOR HERSCHEL FPU

(Obscuration factor in ppm)

Reference C-RS-230

Phase		specification for the considered phase	Total
FPU at delivery		300ppm	300ppm
PLM integration till cryostat closure	50 Days in class 100	200 ppm	500 ppm
Spacecraft AIT till encapsulation		0 ppm	500 ppm
From encapsulation to separation		0 ppm	500 ppm
Micrometeorite and redistribution		50 ppm	550 ppm

*

CLEANLINESS REQUIREMENTS SPECIFICATION

REFERENCE : H-P-1-ASPI-SP-0035

DATE : 26-Sept-2003

ISSUE : 2.2

PAGE : 27/41

ANNEX 1B – ALLOCATIONS FOR PARTICULATE CONTAMINATION FOR HERSCHEL INSIDE CRYOSTAT

Reference C-RS-231

Phase		specification for the considered phase	Total
at delivery to Astrium		200 ppm	200 ppm
PLM integration till cryostat closure	50 Days in class 100	500 ppm	700 ppm
Spacecraft AIT till encapsulation		0 ppm	700 ppm
From encapsulation to separation		0 ppm	700 ppm
Micrometeorite and redistribution		50 ppm	750 ppm

*

CLEANLINESS REQUIREMENTS SPECIFICATION

REFERENCE : H-P-1-ASPI-SP-0035

DATE : 26-Sept-2003

ISSUE : 2.2

PAGE : 28/41

ANNEX 1C - ALLOCATIONS FOR PARTICULATE CONTAMINATION FOR HERSCHEL TELESCOPE

(Obscuration factor in ppm)

Reference C-RS-235

Phase		specification for the considered phase	Total
Telescope at delivery		300 ppm	300ppm
Spacecraft AIT till encapsulation	Days in class 100000 without covers	1890 ppm	2190 ppm
From encapsulation to separation		2300 ppm	4490 ppm
Micrometeorite and redistribution		10 ppm	4500 ppm

*

CLEANLINESS REQUIREMENTS SPECIFICATION

REFERENCE : H-P-1-ASPI-SP-0035

DATE : 26-Sept-2003

ISSUE : 2.2

PAGE : 29/41

ANNEX 1D - ALLOCATIONS FOR PARTICULATE CONTAMINATION FOR HERSCHEL SPACECRAFT

(Obscuration factor in ppm)

Reference C-RS-240 v2

outside CVV

Element		specification for the considered phase	Total
At delivery to satellite AIT		400	400 ppm
AIT till encapsulation	Cleanings during AIT	2500 ppm	2500 ppm
From encapsulation to separation		2300 ppm	4800 ppm
Micrometeorite and redistribution		10 ppm	4810 ppm

NOTE : The values given above are not applicable to external window of the LOU for which the EOL specification is 1200 ppm

SVM

Element		specification for the considered phase	Total
At delivery to satellite AIT		3000 ppm	3000 ppm
AIT till encapsulation	Cleanings during AIT	3400 ppm	3400 ppm
From encapsulation to separation		2300 ppm	5700 ppm
Micrometeorite and redistribution		10 ppm	5710 ppm

*

CLEANLINESS REQUIREMENTS SPECIFICATION

REFERENCE : H-P-1-ASPI-SP-0035

DATE : 26-Sept-2003

ISSUE : 2.2

PAGE : 30/41

ANNEX 1E – ALLOCATIONS FOR PARTICULATE CONTAMINATION FOR PLANCK INSTRUMENTS (FPU)

Reference C-RS-241

Phase		specification for the considered phase	Total
FPU at delivery		300ppm	300 ppm
Spacecraft AIT till encapsulation	days in class 100000 without covers	800 ppm	1100 ppm
From encapsulation to separation		2300 ppm	3400 ppm
Micrometeorite		10 ppm	3410 ppm

*

CLEANLINESS REQUIREMENTS SPECIFICATION

REFERENCE : H-P-1-ASPI-SP-0035

DATE : 26-Sept-2003

ISSUE : 2.2

PAGE : 31/41

ANNEX 1F - ALLOCATIONS FOR PARTICULATE CONTAMINATION FOR PLANCK OPTICAL CAVITY

(Obscuration factor in ppm)

Reference C-RS-245 v2

reflectors

Phase		specification for the considered phase	Total
reflectors at delivery to CSGA		300ppm	300ppm
Telescope AIT	10 days in class 10000	600ppm	900ppm
Spacecraft AIT till encapsulation	days in class 100000 without covers	800 ppm	1700 ppm
From encapsulation to separation		2300 ppm	4000 ppm
Micrometeorite		10 ppm	4010 ppm

Baffle inner side

Phase		specification for the considered phase	Total
delivery		900ppm	900ppm
Spacecraft AIT till encapsulation	Cleaning during AIT	2400 ppm	2400 ppm
From encapsulation to separation		2300 ppm	4700 ppm
Micrometeorite		10 ppm	4710 ppm

*

CLEANLINESS REQUIREMENTS SPECIFICATION

REFERENCE : H-P-1-ASPI-SP-0035

DATE : 26-Sept-2003

ISSUE : 2.2

PAGE : 32/41

ANNEX 1G - ALLOCATIONS FOR PARTICULATE CONTAMINATION FOR PLANCK SPACECRAFT

(Obscuration factor in ppm)

Reference C-RS-250

Outside surfaces of the PLM (except optical cavity)

Element		specification for the considered phase	Total
delivery		3500 ppm	3500 ppm
Spacecraft AIT till encapsulation	Cleanings during the AIT phase	1500 ppm	1500 ppm
From encapsulation to separation		2300 ppm	3800 ppm
Micrometeorite		10 ppm	3810 ppm

SVM

Element		specification for the considered phase	Total
delivery		3000 ppm	3000 ppm
Spacecraft AIT till encapsulation	Cleanings during the AIT phase	3400 ppm	3400 ppm
From encapsulation to separation		2300 ppm	5700 ppm
Micrometeorite		10 ppm	5710 ppm

*

CLEANLINESS REQUIREMENTS SPECIFICATION

REFERENCE : H-P-1-ASPI-SP-0035

DATE : 26-Sept-2003

ISSUE : 2.2

PAGE : 33/41

ANNEX 2A - ALLOCATIONS FOR MOLECULAR CONTAMINATION FOR HERSCHEL AND PLANCK INSTRUMENTS

Reference C-RS-255 v2

FPU

Phase		specification for the considered phase	Total
FPU at delivery		$3 \cdot 10^{-6} \text{ g/cm}^2$	$3 \cdot 10^{-6} \text{ g/cm}^2$
PLM integration till cryostat closure		$1 \cdot 10^{-7} \text{ g/cm}^2$	$3.1 \cdot 10^{-6} \text{ g/cm}^2$
Internal outgassing and air permeation		$2.7 \cdot 10^{-6} \text{ g/cm}^2$	$5.8 \cdot 10^{-6} \text{ g/cm}^2$
In-orbit (outgassing+ thruster plume)		$2 \cdot 10^{-7} \text{ g/cm}^2$	$6 \cdot 10^{-6} \text{ g/cm}^2$

Inside cryostat

Phase		specification for the considered phase	Total
at delivery to Astrium		$2 \cdot 10^{-7} \text{ g/cm}^2$	$2 \cdot 10^{-7} \text{ g/cm}^2$
PLM integration till cryostat closure		$4 \cdot 10^{-7} \text{ g/cm}^2$	$6 \cdot 10^{-7} \text{ g/cm}^2$
Internal outgassing and air permeation		$1 \cdot 10^{-7} \text{ g/cm}^2$	$7 \cdot 10^{-7} \text{ g/cm}^2$
In-orbit (outgassing+ thruster plume)		$2 \cdot 10^{-7} \text{ g/cm}^2$	$9 \cdot 10^{-7} \text{ g/cm}^2$

APPORTIONMENT OF MAXIMUM ALLOWABLE MOLECULAR CONTAMINATION LEVELS (EXPRESSED IN g/cm^2) DURING HERSCHEL INSTRUMENTS LIFE

*

Reference C-RS-260

Phase		specification for the considered phase	Total
Instruments at delivery to spacecraft		$3 \cdot 10^{-6} \text{ g/cm}^2$	$3 \cdot 10^{-6} \text{ g/cm}^2$
Spacecraft AIT till encapsulation		$3 \cdot 10^{-7} \text{ g/cm}^2$	$3.3 \cdot 10^{-6} \text{ g/cm}^2$
From encapsulation to separation		$8 \cdot 10^{-7} \text{ g/cm}^2$	$4.1 \cdot 10^{-6} \text{ g/cm}^2$
In orbit (outgassing + thruster plume)		$1.9 \cdot 10^{-6} \text{ g/cm}^2$	$6 \cdot 10^{-6} \text{ g/cm}^2$

APPORTIONMENT OF MAXIMUM ALLOWABLE MOLECULAR CONTAMINATION LEVELS (EXPRESSED IN g/cm^2) DURING PLANCK INSTRUMENTS LIFE

*

CLEANLINESS REQUIREMENTS SPECIFICATION

REFERENCE : H-P-1-ASPI-SP-0035

DATE : 26-Sept-2003

ISSUE : 2.2

PAGE : 34/41

ANNEX 2B - ALLOCATIONS FOR MOLECULAR CONTAMINATION ON TELESCOPES

Reference C-RS-265

Phase		specification for the considered phase	Total
Telescope at delivery		$2 \cdot 10^{-7} \text{ g/cm}^2$	$2 \cdot 10^{-7} \text{ g/cm}^2$
Spacecraft AIT till encapsulation		$4 \cdot 10^{-7} \text{ g/cm}^2$	$6 \cdot 10^{-7} \text{ g/cm}^2$
From encapsulation to separation		$8 \cdot 10^{-7} \text{ g/cm}^2$	$1.4 \cdot 10^{-6} \text{ g/cm}^2$
In-orbit		$2.6 \cdot 10^{-6} \text{ g/cm}^2$	$4 \cdot 10^{-6} \text{ g/cm}^2$

APPORTIONMENT OF MAXIMUM ALLOWABLE MOLECULAR CONTAMINATION LEVELS (EXPRESSED IN g/cm^2) FOR HERSCHEL TELESCOPE

*

Reference C-RS-270 v2

Reflectors

Phase		specification for the considered phase	Total
Reflectors at delivery		$2 \cdot 10^{-7} \text{ g/cm}^2$	$2 \cdot 10^{-7} \text{ g/cm}^2$
Telescope integration		$3 \cdot 10^{-7} \text{ g/cm}^2$	$5 \cdot 10^{-7} \text{ g/cm}^2$
Spacecraft AIT till encapsulation		$3 \cdot 10^{-7} \text{ g/cm}^2$	$8 \cdot 10^{-7} \text{ g/cm}^2$
From encapsulation to separation		$8 \cdot 10^{-7} \text{ g/cm}^2$	$1.6 \cdot 10^{-6} \text{ g/cm}^2$
In-orbit		$2.4 \cdot 10^{-6} \text{ g/cm}^2$	$4 \cdot 10^{-6} \text{ g/cm}^2$

Baffle inner side - on ground contaminants

Phase		specification for the considered phase	Total
delivery		$5 \cdot 10^{-7} \text{ g/cm}^2$	$5 \cdot 10^{-7} \text{ g/cm}^2$
Spacecraft AIT till encapsulation		$4 \cdot 10^{-7} \text{ g/cm}^2$	$9 \cdot 10^{-7} \text{ g/cm}^2$
From encapsulation to separation		$8 \cdot 10^{-7} \text{ g/cm}^2$	$1.7 \cdot 10^{-6} \text{ g/cm}^2$
In-orbit		0 g/cm^2	$1.7 \cdot 10^{-6} \text{ g/cm}^2$

Baffle inner side - H_2O

Phase		specification for the considered phase	Total
delivery		0 g/cm^2	0 g/cm^2
Spacecraft AIT till encapsulation		0 g/cm^2	0 g/cm^2
From encapsulation to separation		0 g/cm^2	0 g/cm^2
In-orbit		$17 \cdot 10^{-5} \text{ g/cm}^2$	$17 \cdot 10^{-5} \text{ g/cm}^2$

CLEANLINESS REQUIREMENTS SPECIFICATION

REFERENCE : H-P-1-ASPI-SP-0035

DATE : 26-Sept-2003

ISSUE : 2.2

PAGE : 35/41

Baffle inner side - NH₃

Phase		specification for the considered phase	Total
delivery		0 g/cm ²	0 g/cm ²
Spacecraft AIT till encapsulation		0 g/cm ²	0 g/cm ²
From encapsulation to separation		0 g/cm ²	0 g/cm ²
In-orbit		4.8 10 ⁻⁵ g/cm ²	4.8 10 ⁻⁵ g/cm ²

APPORTIONMENT OF MAXIMUM ALLOWABLE MOLECULAR CONTAMINATION LEVELS
(EXPRESSED IN g/cm²) FOR PLANCK TELESCOPE

*

CLEANLINESS REQUIREMENTS SPECIFICATION

REFERENCE : H-P-1-ASPI-SP-0035

DATE : 26-Sept-2003

ISSUE : 2.2

PAGE : 36/41

ANNEX 2C - ALLOCATIONS FOR MOLECULAR CONTAMINATION FOR HERSCHEL AND PLANCK SPACECRAFT

Reference C-RS-275

Outside CVV

Phase	Specification for the considered phase	Total
At delivery to spacecraft	$2 \cdot 10^{-7} \text{ g/cm}^2$	$2 \cdot 10^{-7} \text{ g/cm}^2$
Spacecraft AIT before encapsulation	$2.5 \cdot 10^{-6} \text{ g/cm}^2$	$2.7 \cdot 10^{-6} \text{ g/cm}^2$
From encapsulation to separation	$8 \cdot 10^{-7} \text{ g/cm}^2$	$3.5 \cdot 10^{-6} \text{ g/cm}^2$

NOTE : The values given above are not applicable to external window of the LOU for which the EOL specification is $8.5 \cdot 10^{-6} \text{ g/cm}^2$.

SVM

Phase	Specification for the considered phase	Total
At delivery to spacecraft	$1 \cdot 10^{-6} \text{ g/cm}^2$	$1 \cdot 10^{-6} \text{ g/cm}^2$
Spacecraft AIT before encapsulation	$2.5 \cdot 10^{-6} \text{ g/cm}^2$	$3.5 \cdot 10^{-6} \text{ g/cm}^2$
From encapsulation to separation	$8 \cdot 10^{-7} \text{ g/cm}^2$	$4.3 \cdot 10^{-6} \text{ g/cm}^2$

APPORTIONMENT OF MAXIMUM ALLOWABLE MOLECULAR CONTAMINATION LEVELS (EXPRESSED IN g/cm^2) FOR HERSCHEL SPACECRAFT

Outside surfaces of the PLM (except optical cavity) – on ground contaminants

Phase	Specification for the considered phase	Total
delivery	10^{-6} g/cm^2	10^{-6} g/cm^2
Spacecraft AIT before encapsulation	$6 \cdot 10^{-7} \text{ g/cm}^2$	$1.6 \cdot 10^{-6} \text{ g/cm}^2$
From encapsulation to separation	$8 \cdot 10^{-7} \text{ g/cm}^2$	$2.4 \cdot 10^{-6} \text{ g/cm}^2$
In-orbit	0 g/cm^2	$2.4 \cdot 10^{-6} \text{ g/cm}^2$

Outside surfaces of the PLM (except optical cavity) – H_2O

Phase	Specification for the considered phase	Total
delivery	0 g/cm^2	0 g/cm^2
Spacecraft AIT till encapsulation	0 g/cm^2	0 g/cm^2
From encapsulation to separation	0 g/cm^2	0 g/cm^2
In-orbit	$2.5 \cdot 10^{-5} \text{ g/cm}^2$	$2.5 \cdot 10^{-5} \text{ g/cm}^2$

Outside surfaces of the PLM (except optical cavity) – NH_3

CLEANLINESS REQUIREMENTS SPECIFICATION

REFERENCE : H-P-1-ASPI-SP-0035

DATE : 26-Sept-2003

ISSUE : 2.2

PAGE : 37/41

Phase		Specification for the considered phase	Total
delivery		0 g/cm ²	0 g/cm ²
Spacecraft AIT till encapsulation		0 g/cm ²	0 g/cm ²
From encapsulation to separation		0 g/cm ²	0 g/cm ²
In-orbit		1.2 10 ⁻⁵ g/cm ²	1.2 10 ⁻⁵ g/cm ²

SVM

Phase		Specification for the considered phase	Total
At delivery to spacecraft		1 10 ⁻⁶ g/cm ²	1 10 ⁻⁶ g/cm ²
Spacecraft AIT before encapsulation		2.5 10 ⁻⁶ g/cm ²	3.5 10 ⁻⁶ g/cm ²
From encapsulation to separation		8 10 ⁻⁷ g/cm ²	4.3 10 ⁻⁶ g/cm ²

**APPORTIONMENT OF MAXIMUM ALLOWABLE MOLECULAR CONTAMINATION LEVELS
(EXPRESSED IN g/cm²) FOR PLANCK SPACECRAFT**

*

CLEANLINESS REQUIREMENTS SPECIFICATION

REFERENCE : H-P-1-ASPI-SP-0035

DATE : 26-Sept-2003

ISSUE : 2.2

PAGE : 38/41

ANNEX 3 - ENVIRONMENT CONTROL NATURE AND FREQUENCY OF INSPECTIONS

CLEANLINESS REQUIREMENTS SPECIFICATION

REFERENCE : H-P-1-ASPI-SP-0035

DATE : 26-Sept-2003

ISSUE : 2.2

PAGE : 39/41

	ENVIRONMENT CONTROL						INSPECTION OF SENSITIVE ELEMENTS
	BEFORE AND AFTER ACTIVITY		DURING ACITVITY – SENSITIVE ELEMENTS				
			UNPROTECTED	OPEN	PROTECTED	CLOSED	
	MOLECULAR CONTAMINA.	PARTICULATE CONTAMINA.	MOLECULAR CONTAMINA.	PARTICULATE CONTAMINA.	MOLECULAR CONTAMINA.	PARTICULATE CONTAMINA.	
Classified production or assembly areas	1 inspection before activity	1 inspection before activity	1 inspection of samples/2 weeks after last cleaning	1 inspection per day after last cleaning	1 inspection of samples/4 weeks after last cleaning	1 inspection per week after last cleaning	Inspection of samples on completion of production or upon delivery
Integration areas	1 inspection before activity	1 inspection before activity	1 inspection of samples/2 weeks	Permanent control	1 inspection of samples /4 weeks	1 inspection per week	Inspection of samples every 2 week (if elements unprotected)
Time storage (out of container)	1 inspection before and after storage	1 inspection before and after storage	----	----	----	----	for long time storage, witnesses will be placed in the container and inspected at the end of the storage
Test chambers	Pre and post-test inspection	Pre and post-test inspection					Witnesses will be placed on the sample during tests
- Thermal vacuum	Preparation area	Preparation area	----	----	----	----	In the chambers;
- Temperature	1 inspection/week	Permanent *					They will be inspected after tests
Other test areas	Inspection before test specimen introduction	Inspection before test specimen introduction	1 inspection of samples/week	Permanent Control	1 inspection of samples/2 weeks	1 inspection per day	Inspection of samples after tests or 1 inspection/2 weeks (if elements unprotected)

NATURE AND FREQUENCY OF INSPECTIONS

CLEANLINESS REQUIREMENTS SPECIFICATION

REFERENCE : H-P-1-ASPI-SP-0035

DATE : 26-Sept-2003

ISSUE : 2.2

PAGE : 40/41

	ENVIRONMENT CONTROL						INSPECTION OF SENSITIVE ELEMENTS
	BEFORE AND AFTER ACTIVITY		DURING ACTIVITY - SENSITIVE ELEMENTS				
			UNPROTECTED	OPEN	PROTECTED	CLOSED	
	MOLECULAR CONTAMINA.	PARTICULATE CONTAMINA.	MOLECULAR CONTAMINA.	PARTICULATE CONTAMINA.	MOLECULAR CONTAMINA.	PARTICULATE CONTAMINA.	
Transport	Post-shipment internal inspection of container	----	----	----	----	----	----
Launch preparation areas * If sensitive elements unprotected.	1 inspection before activity	1 inspection before activity	1 inspection of samples/weeks	Permanent control	1 inspection of samples /2 weeks	1 inspection per day	Inspection of samples before fearing installation

NATURE AND FREQUENCY OF INSPECTIONS

CLEANLINESS REQUIREMENTS SPECIFICATION

REFERENCE : H-P-1-ASPI-SP-0035

DATE : 26-Sept-2003

ISSUE : 2.2

PAGE : 41/41

ANNEX 4 - DURATION AND TEMPERATURE OF THE BAKING PROCESSES

Reference C-RS-300

The baking shall be performed at two levels:

- at equipment level, process called pre-baking
 - at cryostat level for Herschel process called baking.
 - At Planck PLM an outgassing prior cryo -tests (TBC) shall be performed.
- The duration of these processes, which is a function of the temperature, is determined by the maximal percentage of the remaining contaminating mass (coming from the materials).
- Standard baking parameters:
- temperature: 80° C
 - duration: 72 hours.
 - For equipments which cannot withstand this temperature level, the bake out duration shall be adapted according to the maximum allowable temperature
-

*

END OF DOCUMENT