

# SPIRE

**SUBJECT: SPIRE FPU Handling and Integration Procedure**

**PREPARED BY: E Sawyer**

**DOCUMENT No: SPIRE-RAL-PRC-001923**

**ISSUE: 3**

**Date: 6/12/04**

**CHECKED BY: .....**

**Date: .....**

**APPROVED BY: .....**

**Date: .....**

**SPIRE**

**Project Document**

SPIRE FPU Handling and Integration  
Procedure

**Ref:** SPIRE-RAL-PRC-  
001923

**Issue:** 3

**Date:** 6/12/04

**Page:** 2 of 35

---

---

**Distribution**

## Change Record

ISSUE	DATE	
Draft	3/12/03	First draft
Draft 2	15/12/03	Additions from MSSL Inclusion of electrical integration procedure
1	20/5/04	Comments from ASSED incorporated as appropriate Drawings added
2	21/10/04	Revised §6.2 to comply with doc. " <i>Making SPIRE ESD Safe - SPIRE-RAL-NOT-002028</i> , Issue 1.0" Deleted Cryoharness Crosstalk test
3	6/12/04	Section 5.1 and 5.2 Deleted requirement to purge during AIT phases

## Table of Contents

<b>CHANGE RECORD</b> .....	<b>3</b>
<b>TABLE OF CONTENTS</b> .....	<b>4</b>
<b>GLOSSARY</b> .....	<b>6</b>
<b>REFERENCES</b> .....	<b>7</b>
<b>APPLICABLE DOCUMENTS</b> .....	<b>7</b>
<b>1. INTRODUCTION</b> .....	<b>7</b>
<b>2. SCOPE</b> .....	<b>9</b>
<b>3. DELIVERY CONDITION</b> .....	<b>9</b>
3.1 SHOCK RECORDERS .....	9
<b>4. TRANSPORT</b> .....	<b>9</b>
4.1 IN DEDICATED EXPERIMENT CONTAINERS .....	9
4.2 AFTER INTEGRATION ON THE SPACECRAFT (IN SPACECRAFT CONTAINER) .....	9
<b>5. STORAGE</b> .....	<b>10</b>
5.1 IN DEDICATED EXPERIMENT CONTAINER.....	10
5.2 OUT OF CONTAINER (IN RR100 CLEANROOM, AWAITING INTEGRATION) .....	10
<b>6. HANDLING</b> .....	<b>10</b>
6.1 GENERAL.....	10
6.2 ESD PROTECTION .....	11
6.3 UNPACKING FROM DEDICATED EXPERIMENT CONTAINER .....	11
6.4 PREPARATION FOR INTEGRATION .....	11
6.5 PREPARATION FOR PACKING.....	12
6.6 PACKING IN CONTAINERS .....	13
<b>7. INTEGRATION</b> .....	<b>13</b>
7.1 REQUIRED TOOLS/MGSE .....	13
7.2 MECHANICAL INTEGRATION TO SPACECRAFT .....	14
7.3 ELECTRICAL INTEGRATION .....	15
7.3.1 General.....	15
7.3.2 Cold Units pre-Integration Electrical Checkout.....	15
7.3.3 Cryo-harness Cross talk checks (now obsolete).....	16
7.3.4 Cryo-Harness grounding check .....	16
7.3.5 Warm electronics mechanical integration .....	16
7.3.6 Initial electrical integration of Warm Electronics .....	17
7.3.7 Electrical Connection (Mating of DRCU and Cold Plane Units).....	18
7.3.7.1 Connection of Internal Cryoharness (SIH-CS) to SPIRE Cold Plane Units .....	18
7.3.7.2 Connection of SVM Cryoharness (SIH-SS) to SPIRE DRCU and SIH-IS to CVV-CB .....	19
7.3.8 SIH EICD Cross-check and Instrument Sign-off.....	26
7.4 ELECTRICAL DISCONNECTION.....	26
7.5 REMOVAL FROM SPACECRAFT .....	26
<b>8. RED TAG ITEMS</b> .....	<b>26</b>

**SPIRE**

**Project Document**

SPIRE FPU Handling and Integration  
Procedure

**Ref:** SPIRE-RAL-PRC-001923

**Issue:** 3

**Date:** 6/12/04

**Page:** 5 of 35

---

---

9. GREEN TAG ITEMS.....	27
ANNEX A - DRAWINGS OF SPIRE FPU MGSE.....	28
ANNEX B - L0 THERMAL STRAP ASSEMBLY.....	34

## Glossary

Cold Units	SPIRE FPU, JFP and JFS
CQM	Cold Qualification Model
DCU	Detector Control Unit
DPU	Digital Processing Unit
DRCU	SPIRE DCU and FCU, i.e the two units with interfaces with the SIH-SS
ESD	Electro static Discharge
FCU	Focal plane Control Unit
FPU	Focal Plane Unit
HOB	Herschel Optical Bench
JFP	Herschel Spire JFET Photometer Module
JFS	Herschel Spire JFET Spectrometer Module
JFET	Junction Field Effect Transistor
L0	Level 0 (Zero)
MSSL	Mullard Space Science Laboratory
OBA	Optical Bench Assembly
PFM	Proto Flight Model
RAL	Rutherford Appleton Laboratory
SIH-CS	Cryogenic Cryoharness between CVV-CB and Instrument
SIH-IS	Intermediate Cryoharness between CVV-CB and SVM-CB
SIH-SS	SVM Cryoharness between SVM-CB and DRCU
SPIRE	Spectral and Photometric Imaging REceiver
TBC	To Be Confirmed
Warm Units	SPIRE DPU, FCU and DCU
WIH	(SPIRE) Warm Interconnection Harness

## References

### Applicable Documents

AD 1	SPIRE-RAL-DOC-001132	SPIRE warm electronics integration plan
AD 2		Obsolete
AD 3	SPIRE-RAL-DOC-000608	SPIRE Harness Definition Document
AD 4	SPIRE-RAL-PRC-002181	SPIRE Warm Electronics Handling and Integration Procedure

### Reference Documents

RD 1	“ <i>Making SPIRE ESD Safe</i> - SPIRE-RAL-NOT-002028, Issue 1.0”	
RD 2	SPIRE INSTRUMENT BLOCK DIAGRAM - SPIRE-RAL-DWG-000646, Issue: 5.8	
RD 3	HP-2-ASED-MN-0753	

## 1. INTRODUCTION

The general AIT flow for the integration of the instrument (Cold Plane Units and Warm Units) is indicated in Figure 1.

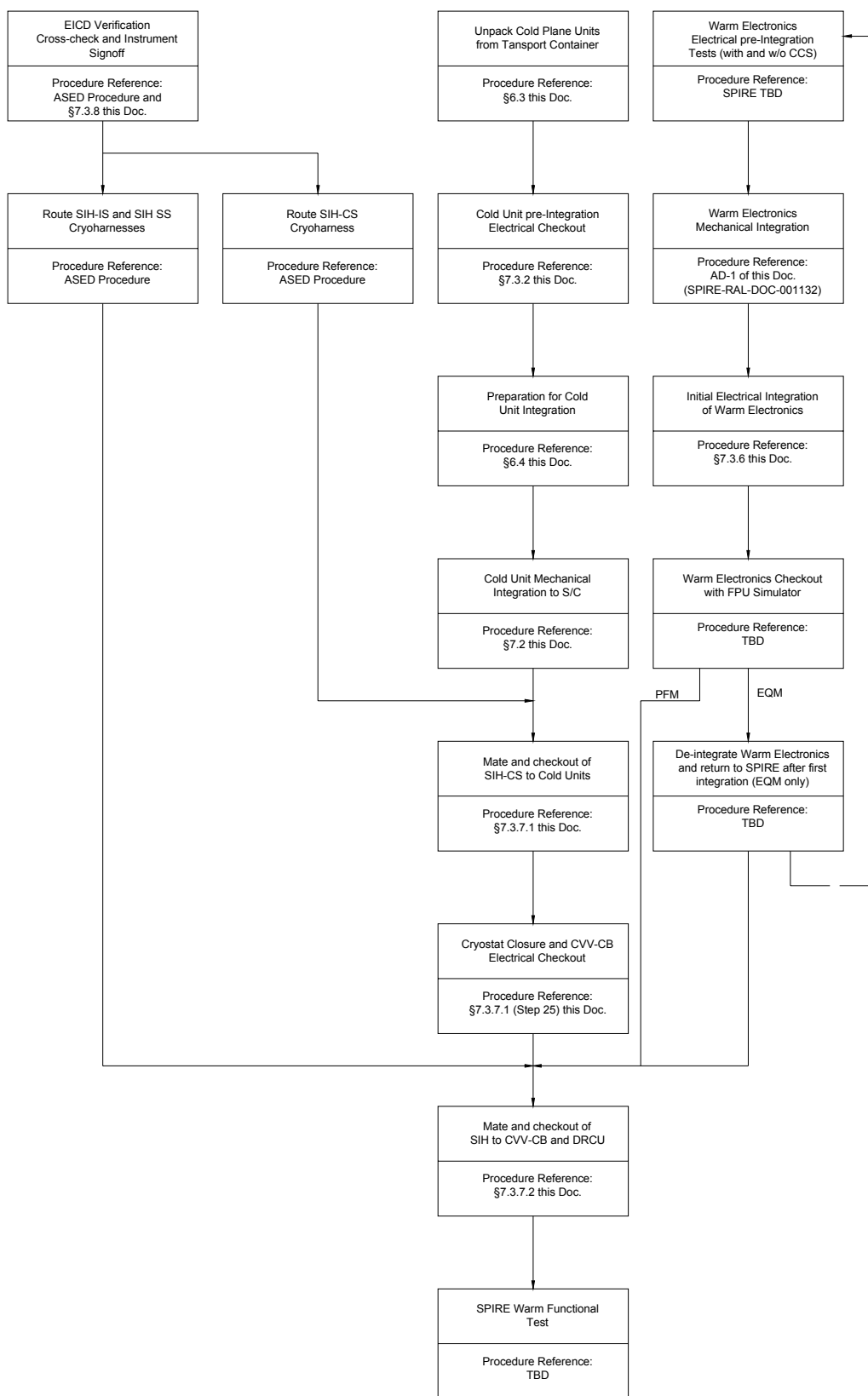

Figure 1 - General AIT Flow for the Integration of the cold plane units and the Warm Electronics to the S/C.



## 2. SCOPE

This document describes the procedures to be followed when handing the SPIRE FPU after delivery to ESA/Alcatel.

It covers the handling and integration procedures to be followed.

It covers both the CQM and PFM units

## 3. DELIVERY CONDITION

The SPIRE instrument is delivered in the following condition:-

The FPU is supplied in a dedicated, re-useable, container.

Alignment cube is fitted to the FPU. (red tag item). See section 8 for further details.

FPU aperture cover fitted (red tag item). See section 8 for further details.

Harnesses between the FPU and JFETs fitted.

FPU and JFETs attached to a baseplate.

Shorting plus or covers will be fitted to all electrical connectors See section 8 for further details.

FPU and JFETs double wrapped in polythene or lumalloy film.

Witness mirrors and/or PFO plates will be fitted to the baseplate

Silica gel moisture control devices will not be used

### 3.1 Shock recorders

Attached to the FPU baseplate, inside the transportation container are re-settable shock indicators These operate in three axis and are set to 5,10 and 25g.

Upon inspection, if any of these recorders have triggered the project team at RAL should be informed.

‘Tip and Tell’ tilt sensors are attached to the outside of the FPU container.

Upon inspection, if any of these recorders have triggered the project team at RAL should be informed

## 4. TRANSPORT

### 4.1 In dedicated experiment containers

Protect from rain and moisture.

Transport in closed vehicles only.

Protect from extremes of temperature, -10°C to +50°C, and prevent the formation of dew at any time.

### 4.2 After integration on the spacecraft (in spacecraft container)

Equivalent to Cleanroom 100 conditions

Assuming that the cryostat is closed:

FPU Aperture cover (red-tag item) shall be removed

Alignment cube (red-tag item) shall be removed

No other specific requirement.

For transport the CVV is closed, evacuated, cooled, OBA in vertical position, z-axis downwards]

## 5. STORAGE

### 5.1 In dedicated experiment container

Ensure aperture cover (red-tag item) is fitted.

Protect from rain and moisture.

Protect from extremes of temperature, 10°C to +30°C.

Alignment cube is fitted.

### 5.2 Out of container (in RR100 cleanroom, awaiting integration)

Ensure aperture cover (red-tag item) is fitted.

Alignment cube is fitted

## 6. HANDLING

### 6.1 General.

The FPU is a delicate optical instrument and should be handled with extreme care at all time.

Contamination of the optical surfaces within the instrument is prevented by the aperture cover. This cover should remain in place unless it is necessary to remove it.

**WARNING:** The bipod legs on two corners of the instrument are very thin section and easily damaged.

Care must be taken at all times not to put side loads into these items. These are at risk at all times when the FPU is not attached to a rigid plate. When it is attached to a rigid plate i.e. the HOB or its transport plate then it is tolerant of loads from vibration, lateral expansion, thermal tests, etc.

## 6.2 ESD protection

The SPIRE instrument contains very sensitive detectors that are susceptible to damage by Electro static discharge. On delivery all connectors will be protected by covers or shorting plugs as appropriate. When handling, all personnel shall wear anti static protection (wrist straps or other suitable method) When the cryoharness is not connected to the DRCU and the FPU Faraday Shield Link connected to Backshell at the warm end, then the FPU is electrically floating and prone to ESD damage.

## 6.3 Unpacking from dedicated experiment container

The FPU is supplied attached to a baseplate together with the JFETs and the JFET harness already integrated. It is bagged in polythene or lumaloy film.

To remove the FPU and JFETs from its container, the following procedure should be followed: -

In an area with a cleanliness of class 100,000 minimum, undo the eight latches that secure the container lid and remove the lid.

The protective bagging encloses the FPU, JFETs and harness and is taped to the baseplate.

Unscrew and remove the four off M8 cap head screws that secure the baseplate to the anti vibration mounts.

Attach the lifting frame Ref MSSSL/5264/404 to a crane and hydra-set. Lower the lifting frame to the baseplate and attach to the eyebolts provided on the baseplate.

The FPU, JFETs and baseplate can now be lifted out of the container with a crane.

Clean bagging material and baseplate, then transport to RR100 airlock.

Remove bagging

The instrument can now enter RR100

Shorting plugs on the JFP and JFS provide ESD protection at this stage.

## 6.4 Preparation for integration

The FPU is supplied with the JFETs and associated harness already fitted.

The following tasks need to be carried out before integration onto the spacecraft.

Only standard tools are required at this stage.

### a) Fitting of JFET supports

The JFETs will be fitted to the spacecraft together with the FPU. They will need supporting during this activity.

The SPIRE supplied MGSE provides provision to support the JFETS during integration.

### b) Fitting of Lifting attachment

Fit the lifting attachment to the FPU as shown in annex A.

Attach the lifting wires to the JFETS.

### c) Alignment cube.

The FPU is supplied with the alignment cube fitted, and should be left in place until all alignment activities are complete, it can be removed and replaced within the alignment tolerances required if necessary..

### d) Thermal strap.

Remove the detector level 0 thermal strap and the Torlon support frames; leave the other two thermal straps in place

e) **Grounding strap.**

The FPU is electrically connected to the baseplate for ESD protection, this strap to be disconnected from the baseplate.

f) **Fitting of RFI tight EMI backshells**

The Herschel/SPIRE EQM cryoharness implements only a subset of the PFM cryoharness bundles for cost a schedule reasons. As a consequence, a number of open connectors are present on the SPIRE Cold Plane Units. These open connectors are to be sealed against RFI by backshells to be supplied by ASED. This activity is to be carried out at this stage providing that the extra length of backshell does not cause a mechanical interference during the integration of the instrument onto the OBA.

g) **Removal from baseplate**

**WARNING:** The bipod legs on two corners of the instrument are very thin section and easily damaged. Care must be taken at all times not to put side loads into these items. These are at risk at all times when the FPU is not attached to a rigid plate.

Undo the five M4 fasteners which secure the Photometer JFET rack (HSJP) (8 JFETs) to the baseplate. Leave the screws in position as they cannot be removed from the JFET rack.

Undo the four M4 fasteners that secure the Spectrometer JFET rack (HSJS) (2 JFETs) to the baseplate. Note that two of these fasteners are studs with nuts on the top, the nuts should be removed and the studs left in place.

The two remaining L0 straps are also secured to the baseplate. To release these from the baseplate, undo the 4 off M4 fasteners on each strap and remove the fasteners. NOTE. The undersides of these straps form the thermal interface to the spacecraft helium tank pods. Their surfaces are flat and soft gold plated, these surfaces can easily be damaged and the thermal performance of the instrument may suffer as a result.

Unbolt the cone from the FPU by undoing the M8 nut, thus leaving the cone on the baseplate.

Undo and remove the 8 fasteners on the blade mounts that attach the FPU to the baseplate.

The FPU and JFETs can now be lifted from the baseplate.

Undo and remove the FPU cone from the baseplate and re-attach it onto the Optical Bench. Note: there are special washers (part number A3/5264/302-3) under the head of each screw and also Vespel insulating bushes (A3/5264/302-2) either side of the mounting flange.

Torque the screws to 8.1 Nm. +/- 10% above running torque

The FPU and JFETs are now ready for integration.

Note: All screws that interface to the spacecraft are metric threads.

## 6.5 Preparation for packing

All units should be wrapped in clean film and replaced in their transit containers. The FPU should be refitted to its baseplate using the following procedure:

Assuming activities described in section 6.3 have been carried out, and the FPU and JFETs are supported on a crane, with the FPU mounting cone still attached to the optics bench.

Remove the cone mount from the spacecraft optics bench

Fix the cone to the SPIRE baseplate using the four M6x21 cap head screws. Note: there are special washers (part number A3/5264/302-3) under the head of each screw and also Vespel insulating bushes (A3/5264/302-2) either side of the mounting flange.

Torque the screws to 8.1 Nm. +/- 10% above running torque.

The Spectrometer JFET studs (2 off) as indicated on interface drawing 0-KE-0104-360. Should still be fitted to the baseplate

Lift the FPU and JFETs using the lifting gear as described in section 6.

Very gently lower the assembly onto the baseplate, ensuring that the JFET studs engage on the JFETs and the cone mount engages in its location on the FPU.

NOTE: the cone is very thin walled section and large moments can be applied if the FPU is not lowered with its interface plane parallel to the baseplate

When all units are resting on the baseplate, fit the attachment screws (M6X21) to the bipod feet as for the cone mount, torque the screws to 8.1 Nm. +/- 10% above running torque.

Fit the M8 nut and Belleville washer to the mounting cone. Torque to 8.25 Nm. +/- 10% above running torque.

Remove the lifting/handling fixture.

Fit the two long bolts and two nuts to secure the spectrometer JFET. Torque the screws to 2.1 Nm. +/- 10% above running torque.

Fit the 5 long bolts to secure the photometer JFET. Torque the screws to 2.1 Nm. +/- 10% above running torque.

Secure the L0 straps to the baseplate using M4X20 socket head cap screws. Torque the screws to 1.5 Nm. +/- 10% above running torque.

Fit the electrical grounding strap between the FPU and the baseplate.

Cover the FPU and JFETs with a double layer of clean polythene or lumaloy film and secure each one with tape to the baseplate.

Fit the lifting frame Ref MSSSL/5264/404 to the four eyebolts in the plate.

## 6.6 Packing in containers.

Fit guide pins onto anti vibration mounts.

Lift the plate into the container.

Remove lifting frame.

Remove guide pins from anti vibration mounts

Secure baseplate to the anti-vibrations mounts in the floor of the transit container.

Fit container lid.

## 7. INTEGRATION

### 7.1 Required tools/MGSE

SPIRE supplied tools/MGSE:-

FPU and JFET handling frame.  
FPU/JFET/baseplate lifting gear  
JFET fixation hardware  
Isolation washers, special screws and studs  
L3 pressure plates 2-off  
L1 strap screws M8 2off, M3 4off (these screws will be prepared for wire locking)  
Wire for locking above screws.  
L1 bushes for the vent line end  
Temporary FPU Grounding Strap including M4 x 6mm fastener to connect to OBA

Supplied by spacecraft

NOTE, Could possibly be attached to the unused harness support bracket holes, or any other convenient tapped hole.

Crane, with Hydraset

Fixation bolts,

FPU M6 12 off -

L0 straps M4 16 off -

L0 pressure plate 4 off

L3 strap M4 4off

Torque wrench to cover 1.5 to 8.25 Nm

Allan key, spanners etc

DVM for electrical isolation testing

## 7.2 Mechanical integration to spacecraft

### FPU and JFETs

Assuming activities described in section 6 have been carried out, and the FPU and JFETs are supported on a crane.

Fix the cone to the SPIRE baseplate using the four M6x21 cap head screws. Note: there are special washers (part number A3/5264/302-3) under the head of each screw and also Vespel insulating bushes (A3/5264/302-2) either side of the mounting flange.

Torque the screws to 8.1 Nm. +/- 10% above running torque.

Fix the Spectrometer JFET studs (2 off) as indicated on interface drawing 0-KE-0104-360. Note these should be screwed into the HOB until 45mm of stud are protruding from the surface.

Lift the FPU and JFETs using the lifting gear as described in section 6.

Very gently lower the assembly onto the HOB, ensuring that the JFET studs engage on the JFETs and the cone mount engages in its location on the FPU.

The flexible ends of the L0 straps are unsupported at this stage and will need to be guided by hand into place as the FPU is lowered

NOTE: the cone is very thin walled section and large moments can be applied if the FPU is not lowered with its interface plane parallel to the HOB

When all units are resting on the HOB, fit the attachment screws (M6X21) to the bipod feet as for the cone mount.

Fit the two Bellville washers and the M8 Kaylock nut to the cone mount. Torque to 8.25Nm.

Remove the lifting/handling fixture.

### L0 straps

- The cooler pump and evaporator straps

These will be in place at this stage.

Ensure that the lower flexibles of these two straps align with the pod interfaces. Fit the attachment screws (ten M4 For the evaporator strap, six M4 screws for the pump)

Torque to specification defined by Astrium

- Detector strap

The light baffle, upper flexible strap should already be in place on the FPU.

Fit the Torlon support frames.

Move the level 0 main strap into place and align the dowel holes (see Assembly drawing 5264/309).

Push in Dowels and ensure that the flexibles are aligned.

Place the cold strap support clamp plates over the top.

Fit the four 4-40 UNC fixings to the cold strap support clamp plates to secure the main strap. Torque to 0.76 Nm. +/- 10% above running torque.

Ensure that the lower flexibles align with the pod interface. Fit the six M4 attachment screws . Torque in accordance with Astrium specification.

Fit the joining plates of the main supports to the joining plates of the upper flexibles, using eight 4-40 UNC bolts and Kaylock nuts. Torque to 0.76 Nm. +/- 10% above running torque

**L1 straps.**

Fit the two L1 straps to the FPU using at each location, one Bellville washer type B0750-056-S and one M8 bolt, torque to 10.5 Nm +/- 10% above running torque. And two M4 bolts and two Bellville washers (type B0375-020-S) under each screw head. Torque to 1.5 Nm +/- 10% above running torque. On final assembly the M8 fasteners to be wire locked to the M4 fasteners. Screws will be prepared for wire locking

**L3 straps.**

Fit the two L3 straps to the JFETs using the attachment hardware (L3 thermal strap clamp provided by SPIRE) as shown in interface drawings 0-KE-0104-350 and 0-KE-0104-360. Torque to 2.5 Nm.

Note. Spacecraft temperature sensors, two sensors on each clamp, fit to this interface.

**Isolation test**

Measure and record the electrical isolation between the chassis of the FPU and the cryostat. Reading should be more than 1 M $\Omega$ . Fix the temporary grounding strap from the FPU to the OBA. Repeat the measurement of the resistance between the cryostat and the FPU to ensure that grounding has been successful, reading should be less than 3 $\Omega$

**7.3 Electrical integration****7.3.1 General**

Several subsystems with the SPIRE FPU are ESD sensitive and especially vulnerable during the integration process. All normal precautions shall be taken when handling the FPU especially when open connectors are present. This includes the wearing of a correctly terminated ESD wrist strap (or equivalent) whilst carrying out any handling operation of the Cold Plane Units or Warm Electronics.

The sequence of the integration is to follow Figure 1.

**7.3.2 Cold Units pre-Integration Electrical Checkout**

The MDM connectors on the FPU, JFP and JFS are probed with a DVM to verify the correct ground isolation and critical signal isolation exists. The connectors are to be cross checked against the SPIRE Harness Definition Document (AD-3). The functions to be checked are outlined in Table 7-1.

Unit	Function
FPU	P-Cal Impedance, S-Cal Impedance, BSM Impedances, SMEC Impedances, Thermistor Impedances, Cooler Impedances
JFP	Photometer analogue ground isolation, JFET Bias, JFET Heater Bias and Bolometer Bias Impedances
JFS	Spectrometer analogue ground isolation, JFET Bias, JFET Heater Bias and Bolometer Bias Impedances

**Table 7-1 Cold unit electrical interface verification**

### 7.3.3 Cryo-harness Cross talk checks (now obsolete)

No cross-talk test will be carried out on the S/C Cryoharness as a part of the instrument integration.

### 7.3.4 Cryo-Harness grounding check

Requisites:

1. The SIH-CS has been routed from the CVV-CB to the location of the I/Fs with SPIRE
2. SPIRE Cold Plane Units have not been integrated onto the OBA

Before any electrical integration of the SPIRE FPU a check of the grounding within the cryoharness shall be carried out. This must verify that the FPU Faraday shield<sup>1</sup> is isolated from the chassis of the CVV/SVM. when the Cold SIH, the Intermediate SIH and the Warm SIH are routed on the S/C but not mated with either the focal plane units or the SVM units. To verify this, it may be necessary to temporarily isolate the unmated cryoharness connectors backshells of the cold units from the CVV. To achieve this, the connector backshells are to be temporarily placed inside plastic bags.

For each of the Cryoharnesses listed in Table 7-2, the isolation between the specified pin on the outside of the CVV-CB and the chassis of the cryostat is to be greater than 5M $\Omega$ .

Cryoharness	Applicability	Pin
C1	EQM and PFM	5
C2	PFM	1
C3	EQM and PFM	2
C4	PFM	1
C5	PFM	1
C6	EQM and PFM	1
C7	PFM	1
C8	PFM	1
C9	PFM	1
C10	EQM and PFM	1
C11	EQM and PFM	1
C12	PFM	1
C13	PFM	1

**Table 7-2 - Cryoharness grounding isolation check.**

### 7.3.5 Warm electronics mechanical integration

Before any electrical integration of the SPIRE FPU, the warm electronics shall be integrated according to the warm electronics integration procedure. AD 4.

<sup>1</sup> The FPU Faraday Shield is fully explained in the SPIRE Harness Definition Document, SPIRE-RAL-PRJ-000608, Issue 1.1, 05/03/03.



### 7.3.6 Initial electrical integration of Warm Electronics

Requisites:

1. The Warm Electronics have completed their pre-Integration tests with the Instrument and PLM EGSE
2. The Warm Electronics have been mechanically integrated to the SVM according to AD-1

Step	Applicability	Activity
1	EQM and PFM	Connect grounding strap from the DPU to the SVM
2	EQM and PFM	Measure and record the resistance between the chassis of the DPU and the SVM and verify that it is less than 10mΩ.
3	EQM and PFM	Connect grounding strap from the DCU to the SVM
4	EQM and PFM	Measure and record the resistance between the chassis of the DCU and the SVM and verify that it is less than 10mΩ.
5	EQM and PFM	Connect grounding strap from the FCU to the SVM
6	EQM and PFM	Measure and record the resistance between the chassis of the FCU and the SVM and verify that it is less than 10mΩ.
7	EQM	Route and secure W1, W3 and W5 to SVM attachment points. Remove and store connector covers
8	PFM	Route and secure W1 through W6 to SVM attachment points. Remove and store connector covers
9	EQM	Remove and store the connector covers from DPU J07, J08 and J09 then mate W1, W3 and W5 to J07, J08 and J09
10	PFM	Remove and store the connector covers from DPU J07 through J12 then mate W1 through W6 to DPU J07 through J12
11	EQM	Remove and store connector covers from FCU J01, FCU J03 and DCU J01 and mate W1, W3 and W5
12	PFM	Remove and store connector covers from FCU J01 through J04, DCU J01 and DCU J02 then mate W1 through W6
13	EQM	Remove and store connector covers from FCU J31, FCU J35 and DCU J03. Route EGSE Bench power supply harnesses and mate to FCU J31, FCU J35 and DCU J03.
14	PFM	Route and secure W7 and W8 to SVM. Remove and store connector covers for FCU J07 and J08. Remove and store connector covers for DCU J03 and J04. Remove and store connector covers from W7 and W8 then mate firstly to the appropriate FCU then DCU connectors.
15	PFM	Route and secure Prime DPU primary power harness from DPU LCL. Remove and store harness connector covers. Remove and store connector cover from DPU J01. Mate harness to LCL connector then to DPU J01.
16	PFM	Route and secure Prime and Redundant DPU primary power harness from DPU LCL. Remove and store harness connector covers. Remove and store connector covers from DPU J01 and J02. Mate harness to LCL connectors then to DPU J01 and J02.
17	EQM	Route and secure S/C 1553 bus harnesses. Remove and store DPU P03, J03, J04 and P04 connector covers

### 7.3.7 Electrical Connection (Mating of DRCU and Cold Plane Units)

When delivered, the JFET units will be fitted with safeing plugs (Type-III See RD 1) on the MDM 37 bias connectors on JFS and JFP. Covers will be present to protect the open MDM 25P detector connectors and the MDM 37S Subsystem connectors. These should be left in place during the mechanical integration.

NOTE: This order of connection must be maintained to protect the sensitive electronics in the SPIRE FPU and warm electronics.

It is not planned to use connector savers on the cold end of the cryo-harness as multiple insertions are not expected.

#### 7.3.7.1 Connection of Internal Cryoharness (SIH-CS) to SPIRE Cold Plane Units

Requisites:

1. External cryoharness is not connected to the CVV vacuum connectors (CVV-CB)
2. JFP and JFS have Type-III Safeing plugs connected.
3. Cryoharness is routed within cryostat but not mated to instrument
4. The Cold Units are mechanically integrated onto the OBA
5. FPU Grounding Strap shorts FPU Chassis to the OBA

Step Number	Applicability	Activity
1	EQM only	Install RFI tight backshells on any remaining open connectors on FPU, JFP and JFS
2	PFM only	Mate the 128-way safeing plug for harnesses C11 and C13 (SPIRE Type-VIII) to the mating connector on the outside of the CVV (CVV-CB P29 and CVV-CB P30)
3	EQM only	Connect the cryo-harness C10 and C11 to connectors J19, J21, J23, J25, J27 and J29 to the FPU.
4	PFM only	Connect the cryo-harness C10, C11, C12 and C13 to connectors J19 through J30 to the FPU.
5	EQM and PFM	Mate the 128-way safeing plug for C1 (SPIRE Type-VI) to the mating connector on the outside of the CVV (CVV-CB P32)
6	EQM and PFM	Mate the 128-way safeing plug for harnesses C3 (SPIRE Type-V) to the mating connector on the outside of the CVV (CVV-CB P26)
7	EQM only	Remove the Type-III safeing plugs from JFP J27
8	PFM only	Remove the Type-III safeing plugs from JFP J25 and J27
9	EQM and PFM	Mate JFP P25 and JFP P27 to JFP J25 and JFP J27
10	EQM only	Remove the Type-III safeing plugs from JFP J28
11	PFM only	Remove the Type-III safeing plugs from JFP J26 and J28
12	EQM and PFM	Mate JFP P26 and JFP P28 to JFP J26 and JFP J28
13	PFM only	Remove the Type-III safeing plug from JFS J09
14	EQM and PFM	Mate JFS P09 to JFS J09
15	PFM only	Remove the Type-III safeing plug from JFS J10
16	EQM and PFM	Mate JFS P10 to JFS J10
17	EQM only	Mate 128-way safeing cover for C6 (SPIRE Type-VII) to CVV-CB P24
18	PFM only	Mate 128-way safeing cover for C2, C4, C5, C6, C7, C8 and C9 (SPIRE Type-VII) to CVV-CB P31, P22, P23, P24, P25, P27 and P28
19	EQM only	Mate JFP P13, P14, P15 and P16 to JFP J13, J14, J15 and J16

Step Number	Applicability	Activity
20	PFM only	Mate JFP P01 through P24 to JFP J01 through J25
21	EQM only	Mate JFS P05 and P06 to JFS J05 and J06
22	PFM only	Mate JFS P01 through P24 to JFS J01 through J07
23	EQM and PFM	Remove red-tag FPU grounding strap
24	EQM and PFM	During the final closure of the cryostat, the remaining red-tag items are to be removed from the cold plane units
25	EQM PFM(TBD)	Using two ASSED provided Break-out boxes and SPIRE provided EGSE, the grounding configuration electrical interface will be probed at the 128-Way CVV-CB <sup>2</sup>

After this stage has been carried out, the cold plane instrument is safe from an ESD point of view. The Cryostat can be closed (provided Cold Plane Red-tag Items have been removed!) and transported from one establishment to another.

### ***7.3.7.2 Connection of SVM Cryoharness (SIH-SS) to SPIRE DRCU and SIH-IS to CVV-CB***

Requisites:

1. External cryoharness (SIH-IS and SIH-SS) is routed but not connected to the CVV vacuum connectors
2. The SIH-IS and SIH-SS Cryoharnesses are mated at the SVM-CB<sup>3</sup>
3. The SIH-CS is connected to the instrument
4. The SIH-IS is not connected to the CVV-CB

This part of the electrical integration carries out the following activities:

- Verification of the correct grounding configuration of the Cold Plane Units and the Cryoharness
- Partial verification of critical electrical interfaces between the cryoharness and the Cold Plane Units
- Safe mating of the cold plane units and the DRCU

See Table 7-3 for procedure details.

<sup>2</sup> This step is required during the EQM programme as the SIH-CS will be in

<sup>3</sup> Providing that SIH-IS is not connected to the CVV-CB and that the SIH-SS is not mated with the DRCU, the SIH-IS and SIH-SS can be mated in no particular order without any particular ESD precautions.

Step		Activity	Notes	Applicability	
				EQM	PFM
1.1	Prepare cryoharness DRCU connector backshells	Remove inspection covers from cryoharness backshells (DCU J05 to J32 and FCU J11, J12, J13, J14, J17, J18, J19, J20, J21, J22, J23, J24, J25, J26, J29 and J30)		No	Yes
1.2		Remove inspection covers from cryoharness backshells (DCU J14, J15, J16, J29, J30, J31, J32 and FCU J11, J13, J17, J19, J21, J23, J25 and J29)		Yes	No
1.3		Break and electrically isolate all the FPU Faraday Shield Link connection to the DRCU backshells		Yes	Yes
2.1.1	Connect cryogenic Phot Analogue grounds to DRCU via LIAs	Mate SIH-SS-06 P14, P15 and P16 to DCU J14, J15 and J16		Yes	Yes
2.1.2		Remove SPIRE Safeing Plug Type-VII from CVV-CB J24		Yes	Yes
2.1.3		Mate SIH-IS-06 P24 to CVV-CB J24	PLW Analogue ground connected to cold end via detector harness. JFETs connected to analogue ground via ESD resistors	Yes	Yes
2.2.1		Mate SIH-SS-09 P05, P06 and P07 to DCU J05, J06 and J07		No	Yes
2.2.2		Remove SPIRE Safeing Plug Type-VII from CVV-CB J28		No	Yes
2.2.3		Mate SIH-IS-09 P28 to CVV-CB J28	PSW Analogue ground connected to cold end via detector harness. JFETs connected to analogue ground via ESD resistors	No	Yes

Step		Activity	Notes	Applicability	
				EQM	PFM
2.3.1		Mate SIH-SS-04 P20, P21 and P22 to DCU J20, J21 and J22		No	Yes
2.3.2		Remove SPIRE Safeing Plug Type-VII from CVV-CB J22		No	Yes
2.3.3		Mate SIH-IS-04 P22 to CVV-CB J22	PMW Analogue ground connected to cold end via detector harness. JFETs connected to analogue ground via ESD resistors	No	Yes
3.1	Connect cryogenic Phot Analogue grounds to Bias harness	Mate SPIRE Safeing Plug Type-IX to SIH-SS-03 P30		Yes	Yes
3.2		Remove SPIRE Safeing Plug Type-V from CVV-CB J26		Yes	Yes
3.3		Mate SIH-IS-03 P26 to SVM-CB J26	PLW, PMW and PSW Analogue grounds connected to cold end via terminated bias harness. JFETs connected to analogue ground via ESD resistors	Yes	Yes
4.1	Remove Phot harness connections to DCU	Demate: SIH-SS-C6 P14, P15 and P16 from DRCU. Place connector dust caps over contacts		Yes	No
4.2		Demate: SIH-SS-C6 P14, P15 and P16 from DRCU. SIH-SS-C9 P05, P06 and P07 from DRCU SIH-SS-C4 P20, P21 and P22 from DRCU Place connector dust caps over contacts		No	Yes

Step		Activity	Notes	Applicability	
				EQM	PFM
5.0	Mate remaining Phot. Harnesses	Mate: SIH-IS-05 P23 to CVV-CB J23 SIH-IS-07 P25 to CVV-CB J25 SIH-IS-08 P27 to CVV-CB J27	All Phot harnesses mated to CVV-CB but not connected to DRCU. Safeing plug on SIH-C3-P30 keeping entire Phot cryo system safe!	No	Yes
6.1	Confirmation of Phot Harnesses grounding	Measure isolation of FPU Faraday shield on SIH-SS-P29 from connector backshell	Correct configuration of FPU faraday shield confirmed for Phot harnesses	Yes	Yes
6.2		Remove SPIRE Safeing plug Type-IX from SIH-SS-03-P30	SPIRE is temporarily ESD vulnerable	Yes	Yes
6.3		Measure isolation of Pins 21, 30 and 78 of SIH-SS-03 P30 from connector backshell.	Isolation test to be carried out with a DVM. The common terminal to be connected firstly to backshell of P30. The measure probe is then used on the pin contacts	Yes	Yes
6.4		Mate SPIRE Safeing Plug Type-IX to SIH-SS-03 P30	SPIRE is ESD safe	Yes	Yes
7.1	Safe mating of Spect harnesses to CVV-CB	Mate SPIRE Safeing Plug Type-X to SIH-SS-01 P32		Yes	Yes
7.2		Remove SPIRE Safeing plug Type-VII from CVV-CB-J31		No	Yes
7.3		Mate SIH-SS-02 P23, P24, P26 and P26 to DRCU J23, J24, J25 and J26		Yes	Yes
7.4		Mate SIH-IS-02 P31 to CVV-CB J31	SSW (and SLW!) analogue grounds connected to DRCU Spec Analogue ground plane	No	Yes
7.5		Remove SPIRE Safeing plug Type-VI from CVV-CB-J32		No	Yes
7.6		Mate SIH-IS-01 J32 to CVV-CB P32		Yes	Yes
7.7		Demate: SIH-SS-C02 P23, P24, P24 and P26 from DRCU		Yes	Yes

8.1	Confirmation of Spect Harnesses	Measure isolation of FPU Faraday shield on SIH-SS-01 P31 from connector backshell	Correct configuration of FPU faraday shield confirmed for Spect harnesses	Yes	Yes
8.2		Remove SPIRE Safeing plug Type-X from SIH-SS-03-P32	SPIRE is temporarily ESD vulnerable	Yes	Yes
8.3		Measure isolation of Pins 6 and 12 of SIH-SS-01 P32 from connector backshell.	Isolation test to be carried out with a DVM. The common terminal to be connected firstly to backshell of P32. The measure probe is then used on the pin contacts	Yes	Yes
8.4		Mate SPIRE Safeing Plug Type-IX to SIH-SS-03 P30	SPIRE is ESD safe	Yes	Yes
9.1	Connection of S/S Harness to CVV-CB	Mate SIH-IS-10 P32 to CVV-CB J32	Check critical impedances up cryoharness towards Cold Plane Units with DVM	Yes	Yes
9.2		Remove SPIRE Safeing Plug Type VIII from CVV-CB J30		Yes	Yes
9.3		Mate SIH-IS-11 P30 to CVV-CB J30	Check critical impedances up cryoharness towards Cold Plane Units with DVM	Yes	Yes
9.4		Mate SIH-IS-12 P33 to CVV-CB J33	Check critical impedances up cryoharness towards Cold Plane Units with DVM	No	Yes
9.5		Remove SPIRE Safeing Plug Type VIII from CVV-CB J29		No	Yes
9.6		Mate SIH-IS-13 P29 to CVV-CB J29	Check critical impedances up cryoharness towards Cold Plane Units with DVM	No	Yes
10.1	Confirmation of Phot Harnesses grounding	Measure isolation of FPU Faraday shield on SIH-SS-01 P31 from connector backshell	Correct configuration of FPU faraday shield confirmed for FPU Subsystem harnesses	Yes	Yes
11.1		Connect the FPU Faraday Shield link to all the SIH-SS harnesses and re-install the connector covers		Yes	Yes

12.1	Final iconnection of Photometer and Spectrometer Bias and Detector output channels	Mate SIH-SS-03 P29 to DCU J29		Yes	Yes
12.2		Demate SPIRE Safeing Plug Type-IX from SIH-SS-03 J30		Yes	Yes
12.3		Mate SIH-SS-03 P30 to DCU J30	Check analogue ground and critical impedances up cryoharness towards Cold Plane Units	Yes	Yes
12.4		Mate SIH-SS-01 P31 to DCU J31		Yes	Yes
12.5		Demate SPIRE Safeing Plug Type-X from SIH-SS-01 J32		Yes	Yes
12.6		Mate SIH-SS-01 P32 to DCU J32	Check analogue ground and critical impedances up cryoharness towards Cold Plane Units	Yes	Yes
12.7		Mate SIH-SS-04 P20, P21 and P22 to DCU J20, J21 and J22	Idem	No	Yes
12.8		Mate SIH-SS-05 P17, P18 and P19 to DCU J17, J18 and J19	Idem	No	Yes
12.9		Mate SIH-SS-06 P14, P15 and P16 to DCU J14, J15 and J16	Idem	Yes	Yes
12.10		Mate SIH-SS-07 P11, P12 and P13 to DCU J11, J12 and J13	Idem	No	Yes
12.11		Mate SIH-SS-08 P08, P09 and P10 to DCU J08, J09 and J10	Idem	No	Yes
12.12		Mate SIH-SS-09 P05, P06 and P07 to DCU J05, J06 and J07	Idem	No	Yes
12.13		Mate SIH-SS-01 P32, P27 and P28 to DCU J32, J27 and J28	Idem	Yes	Yes
12.14		Mate SIH-SS-02 P23, P24, P26 and P26 to DRCU J23, J24, J25 and J26	Idem. Phot and Spect detectors fully connected to DRCU	No	Yes



13.1	Final Connection of Cryoharness to FCU	Mate SIH-SS-10 P11, P23 and P25 to FCU		Yes	Yes
13.2		Mate SIH-SS-11 P13, P17, P19, P21 and P29 to FCU		No	Yes
13.3		Mate SIH-SS-11 P13 and P29 to FCU		Yes	No
13.4		Mate EGSE harnesses to SIH-SS-11 P17, P19 and P29		Yes	No
13.5		Mate SIH-SS-13 P12, P24 and P26 to FCU		No	Yes
13.6		Mate SIH-SS-12 P14, P26, P20, P22and P30 to FCU		No	Yes

**Table 7-3 Sequence for the mating of the cold units and the warm units via the cryoharness**

### 7.3.8 SIH EICD Cross-check and Instrument Sign-off

For EQM: This cross-check of the SIH EICD involves the connection of the ASED harness checkout EGSE to the SPIRE instrument test cryoharness which has been programmed according to the SIH EICD.

ASED are to provide the procedure for the test.

A review of the results of the test will be carried out to give clearance for the integration of the SIH to the DRCU and Cold Units.

For PFM: TBD

## 7.4 Electrical disconnection

Disconnection is the reverse of connection

## 7.5 Removal from spacecraft

**WARNING:** The bipod legs on two corners of the instrument are very thin section and easily damaged. Care must be taken at all times not to put side loads into these items. These are at risk at all times when the FPU is not attached to a rigid plate.

Unbolt the cone from the FPU by undoing the M8 nut, thus leaving the cone on the baseplate.

Remove all electrical connections, see section 7.4

Undo the five M4 fasteners which secure the Photometer JFET rack (HSJFP) to the HOB.

Undo the four M4 fasteners that secure the Spectrometer JFET rack (HSJFS) to the HOB. Note that two of these fasteners are studs with nuts on the top.

Undo the 6 off M4 fasteners on each L0 strap and remove, separate the cold strap from the helium tank pod. NOTE. The underside of these straps form the thermal interface to the spacecraft helium tank pods. Their surfaces are flat and soft gold plated, these surfaces can easily be damaged and the thermal performance of the instrument may suffer as a result.

Remove the Detector Level 0 strap from the supports by undoing the clamps at the top of the strap support frames, the lower flexibles from the spacecraft pod interface and the bolts at the joining plates with the upper flexibles.

Undo and remove the one M8 and two M4 screws from each of two L1 cold strap interface, separate the cold strap from the FPU

Undo and remove the two M4 screws from the L3 interfaces on each JFET, separate the cold strap from the JFET.

Undo and remove the 8 fasteners that attach the FPU to the baseplate.

The FPU and JFETs can now be lifted from the HOB

## 8. RED TAG ITEMS

The following red tag items are fitted to the FPU when delivered.

- 1 An aperture cover
- 2 Alignment cube
- 3 Temporary grounding strap
- 4 Shorting plugs

When removed all red tag items shall be bagged and stored in the dedicated “red tag box”.

The aperture cover is removed by unscrewing the four 2-56 UNC (imperial) cap head screws, which are captive in the cover, and lifting the cover clear.

The alignment cube is removed by unscrewing the three fixing screws and lifting clear.

## **9. GREEN TAG ITEMS**

There are no green tag items

**SPIRE**

**Project Document**

SPIRE FPU Handling and Integration  
Procedure

**Ref:** SPIRE-RAL-PRC-  
001923

**Issue:** 3

**Date:** 6/12/04

**Page:** 28 of 35

**ANNEX A - DRAWINGS OF SPIRE FPU MGSE**

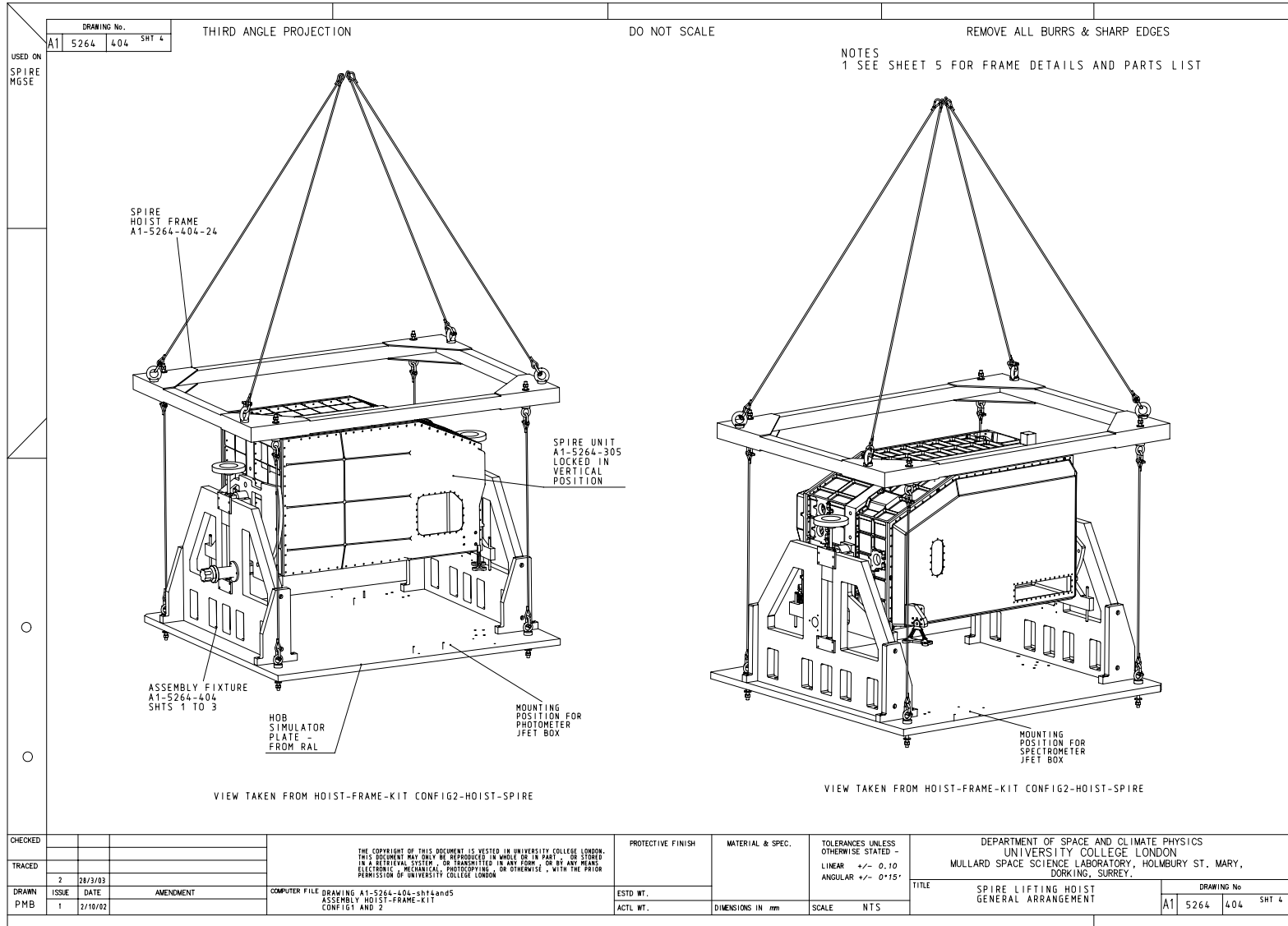

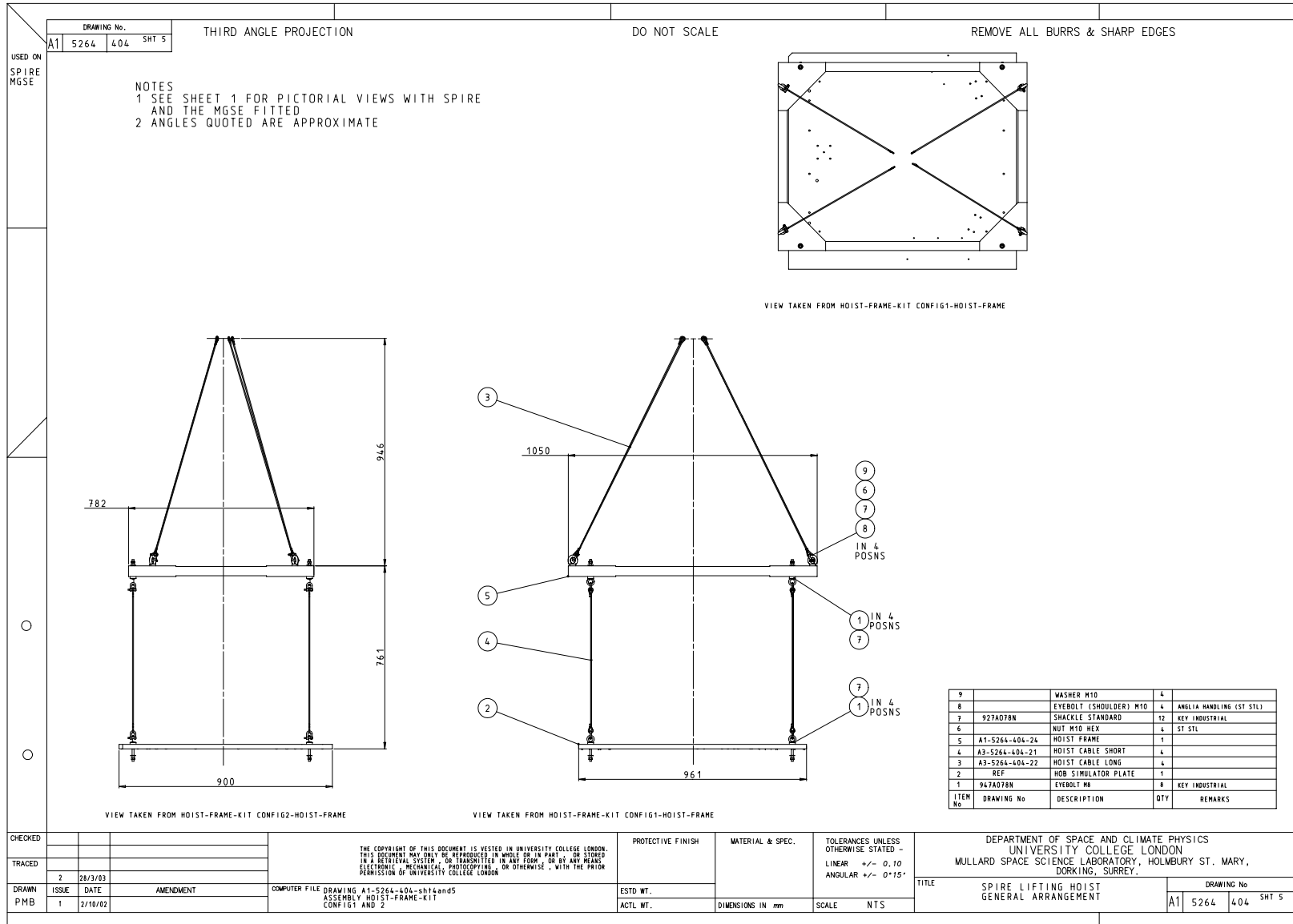

USED ON SPIRE MOSE	DRAWING No. A1 5264 404 SHT 6 OF 7	THIRD ANGLE PROJECTION	DO NOT SCALE	REMOVE ALL BURRS & SHARP EDGES																																																							
NOTES 1 DIMENSIONS ARE NOMINAL AND MAY VARY DUE TO MANUFACTURING TOLERANCES																																																											
NOTE 1 SEE SHEET 7 FOR SPIRE INSTALLATION LIFTING REFERENCE DIMENSIONS																																																											
<p>VIEW SCALE 0.25 : 1</p>		<p>VIEW SCALE 0.25 : 1</p>																																																									
<table border="1" style="width: 100%; border-collapse: collapse;"> <thead> <tr> <th>ITEM No</th> <th>DRAWING No</th> <th>DESCRIPTION</th> <th>QTY</th> <th>REMARKS</th> </tr> </thead> <tbody> <tr><td>10</td><td></td><td>SCREW M6x20 L SKT CAP HD</td><td>4</td><td>ST STEEL</td></tr> <tr><td>9</td><td></td><td>SCREW M8x25 L SKT CAP HD</td><td>4</td><td>ST STEEL</td></tr> <tr><td>8</td><td></td><td>M10 NUT HEX FULL</td><td>2</td><td>ST STEEL</td></tr> <tr><td>7</td><td>927A078N</td><td>SHACKLE</td><td>3</td><td>KEY INDUSTRIAL LTD</td></tr> <tr><td>6</td><td></td><td>SHOULDER EYEBOLT M10</td><td>2</td><td>ANGLIA HANDLING</td></tr> <tr><td>5</td><td></td><td></td><td></td><td></td></tr> <tr><td>4</td><td>A3-5264-404-22</td><td>HOIST CABLE</td><td>3</td><td></td></tr> <tr><td>3</td><td>A3-5264-404-16</td><td>REAR LIFT CHANNEL</td><td>1</td><td></td></tr> <tr><td>2</td><td>A3-5264-404-15</td><td>REAR LIFT PLATE</td><td>1</td><td></td></tr> <tr><td>1</td><td>A2-5264-404-34</td><td>FRONT LIFT BRACKET</td><td>1</td><td></td></tr> </tbody> </table>					ITEM No	DRAWING No	DESCRIPTION	QTY	REMARKS	10		SCREW M6x20 L SKT CAP HD	4	ST STEEL	9		SCREW M8x25 L SKT CAP HD	4	ST STEEL	8		M10 NUT HEX FULL	2	ST STEEL	7	927A078N	SHACKLE	3	KEY INDUSTRIAL LTD	6		SHOULDER EYEBOLT M10	2	ANGLIA HANDLING	5					4	A3-5264-404-22	HOIST CABLE	3		3	A3-5264-404-16	REAR LIFT CHANNEL	1		2	A3-5264-404-15	REAR LIFT PLATE	1		1	A2-5264-404-34	FRONT LIFT BRACKET	1	
ITEM No	DRAWING No	DESCRIPTION	QTY	REMARKS																																																							
10		SCREW M6x20 L SKT CAP HD	4	ST STEEL																																																							
9		SCREW M8x25 L SKT CAP HD	4	ST STEEL																																																							
8		M10 NUT HEX FULL	2	ST STEEL																																																							
7	927A078N	SHACKLE	3	KEY INDUSTRIAL LTD																																																							
6		SHOULDER EYEBOLT M10	2	ANGLIA HANDLING																																																							
5																																																											
4	A3-5264-404-22	HOIST CABLE	3																																																								
3	A3-5264-404-16	REAR LIFT CHANNEL	1																																																								
2	A3-5264-404-15	REAR LIFT PLATE	1																																																								
1	A2-5264-404-34	FRONT LIFT BRACKET	1																																																								
<table border="1" style="width: 100%; border-collapse: collapse;"> <tr> <td style="width: 5%;">CHECKED</td> <td style="width: 5%;">5</td> <td style="width: 10%;">2/2/04</td> <td style="width: 20%;">SUPPORT PLATE FOR JPEI BOLTS ADDED</td> <td style="width: 10%;"></td> <td style="width: 10%;"></td> <td style="width: 10%;"></td> <td style="width: 10%;"></td> <td style="width: 10%;"></td> <td style="width: 10%;"></td> </tr> <tr> <td></td> <td>4</td> <td>28/1/04</td> <td>ASSEMBLY JIG PARTS REMOVED DUE TO SPACE LIMITATIONS</td> <td></td> <td></td> <td></td> <td></td> <td></td> <td></td> </tr> <tr> <td></td> <td>3</td> <td>8/8/03</td> <td>FRONT LIFT BRACKET REPLACED WITH FRONT LIFT STRAP</td> <td></td> <td></td> <td></td> <td></td> <td></td> <td></td> </tr> <tr> <td></td> <td>2</td> <td>28/3/03</td> <td></td> <td></td> <td></td> <td></td> <td></td> <td></td> <td></td> </tr> <tr> <td></td> <td>1</td> <td>2/10/02</td> <td></td> <td></td> <td></td> <td></td> <td></td> <td></td> <td></td> </tr> </table>					CHECKED	5	2/2/04	SUPPORT PLATE FOR JPEI BOLTS ADDED								4	28/1/04	ASSEMBLY JIG PARTS REMOVED DUE TO SPACE LIMITATIONS								3	8/8/03	FRONT LIFT BRACKET REPLACED WITH FRONT LIFT STRAP								2	28/3/03									1	2/10/02												
CHECKED	5	2/2/04	SUPPORT PLATE FOR JPEI BOLTS ADDED																																																								
	4	28/1/04	ASSEMBLY JIG PARTS REMOVED DUE TO SPACE LIMITATIONS																																																								
	3	8/8/03	FRONT LIFT BRACKET REPLACED WITH FRONT LIFT STRAP																																																								
	2	28/3/03																																																									
	1	2/10/02																																																									
<table border="1" style="width: 100%; border-collapse: collapse;"> <tr> <td style="width: 10%;"></td> <td style="width: 10%;"></td> <td style="width: 10%;"></td> <td style="width: 10%;"></td> <td style="width: 10%;"></td> <td style="width: 10%;"></td> <td style="width: 10%;"></td> <td style="width: 10%;"></td> <td style="width: 10%;"></td> <td style="width: 10%;"></td> </tr> <tr> <td>ESTD WT.</td> <td></td> <td>PROTECTIVE FINISH</td> <td></td> <td>MATERIAL &amp; SPEC.</td> <td></td> <td>TOLERANCES UNLESS OTHERWISE STATED -</td> <td></td> <td colspan="3" style="text-align: center;">                 DEPARTMENT OF SPACE AND CLIMATE PHYSICS                  UNIVERSITY COLLEGE LONDON                  MULLARD SPACE SCIENCE LABORATORY, HOLMBURY ST. MARY,                  DORKING, SURREY.             </td> </tr> <tr> <td>ACTL WT.</td> <td></td> <td></td> <td></td> <td></td> <td></td> <td>LINEAR +/- 0.10</td> <td></td> <td colspan="3" style="text-align: center;">                 TITLE                  SPIRE LIFTING FOR                  INSTALLATION             </td> </tr> <tr> <td></td> <td></td> <td></td> <td></td> <td></td> <td></td> <td>ANGULAR +/- 0°15'</td> <td></td> <td colspan="3" style="text-align: center;">                 DRAWING No                  A1 5264 404 SHT 6 OF 7             </td> </tr> <tr> <td></td> <td></td> <td></td> <td></td> <td></td> <td></td> <td>SCALE SEE VIEWS</td> <td></td> <td colspan="3"></td> </tr> </table>															ESTD WT.		PROTECTIVE FINISH		MATERIAL & SPEC.		TOLERANCES UNLESS OTHERWISE STATED -		DEPARTMENT OF SPACE AND CLIMATE PHYSICS UNIVERSITY COLLEGE LONDON MULLARD SPACE SCIENCE LABORATORY, HOLMBURY ST. MARY, DORKING, SURREY.			ACTL WT.						LINEAR +/- 0.10		TITLE SPIRE LIFTING FOR INSTALLATION									ANGULAR +/- 0°15'		DRAWING No A1 5264 404 SHT 6 OF 7									SCALE SEE VIEWS					
ESTD WT.		PROTECTIVE FINISH		MATERIAL & SPEC.		TOLERANCES UNLESS OTHERWISE STATED -		DEPARTMENT OF SPACE AND CLIMATE PHYSICS UNIVERSITY COLLEGE LONDON MULLARD SPACE SCIENCE LABORATORY, HOLMBURY ST. MARY, DORKING, SURREY.																																																			
ACTL WT.						LINEAR +/- 0.10		TITLE SPIRE LIFTING FOR INSTALLATION																																																			
						ANGULAR +/- 0°15'		DRAWING No A1 5264 404 SHT 6 OF 7																																																			
						SCALE SEE VIEWS																																																					

THE COPYRIGHT OF THIS DOCUMENT IS RESERVED BY UNIVERSITY COLLEGE LONDON  
 IN A REGISTERED STATE OF THE UNITED KINGDOM AND IS LOANED TO YOU BY THE  
 PERMISSION OF UNIVERSITY COLLEGE LONDON

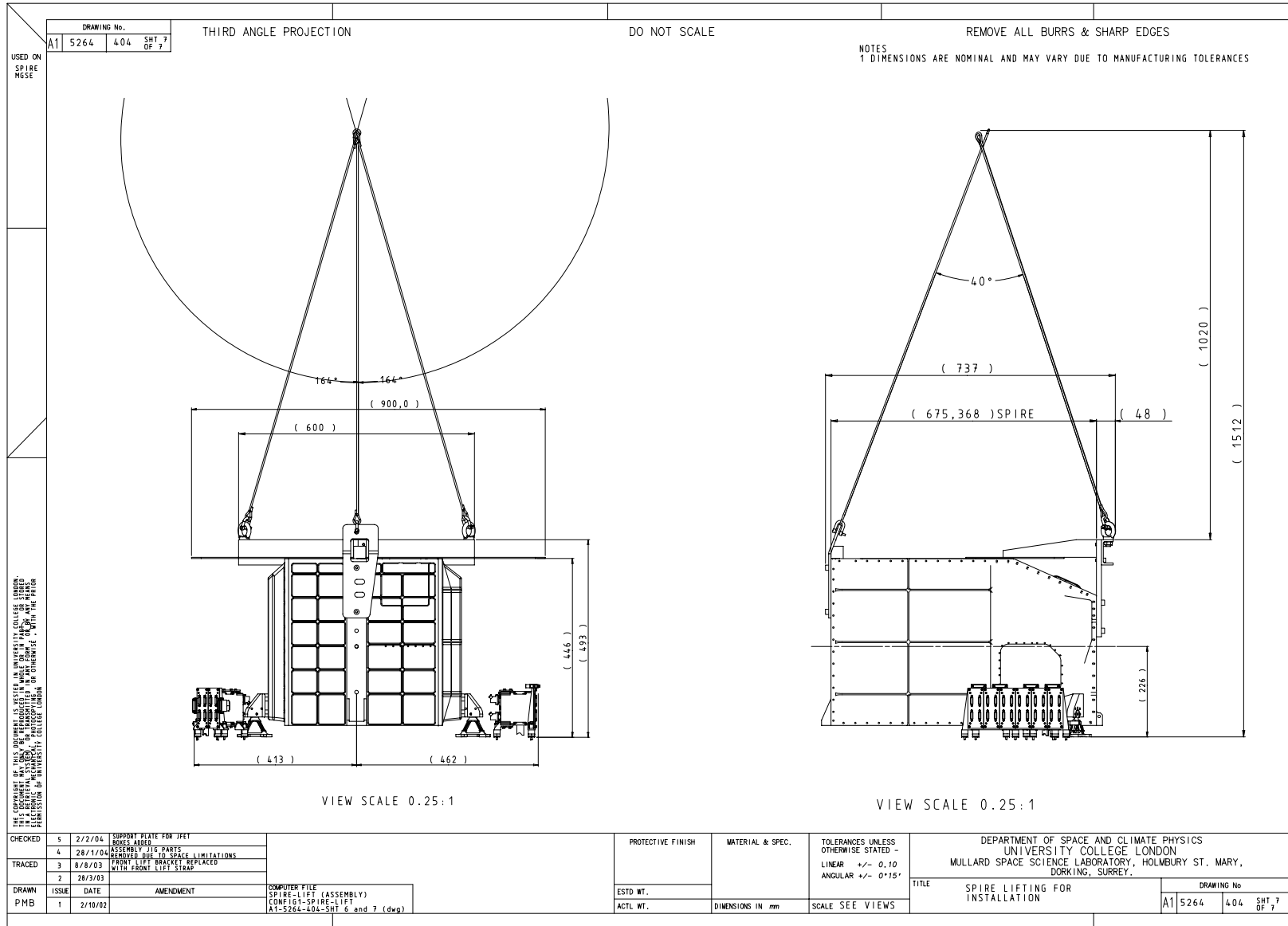

THE COPYRIGHT IN THIS DOCUMENT BELONGS TO UNIVERSITY COLLEGE LONDON. PERMISSION IS GRANTED BY UNIVERSITY COLLEGE LONDON TO REPRODUCE THIS DRAWING FOR THE PURPOSES OF THE PROJECT, PROVIDED THAT THE REPRODUCTION IS FOR THE USE OF UNIVERSITY COLLEGE LONDON.



# SPIRE

## Project Document

### SPIRE FPU Handling and Integration Procedure

**Ref:** SPIRE-RAL-PRC-001923  
**Issue:** 3  
**Date:** 6/12/04  
**Page:** 33 of 35

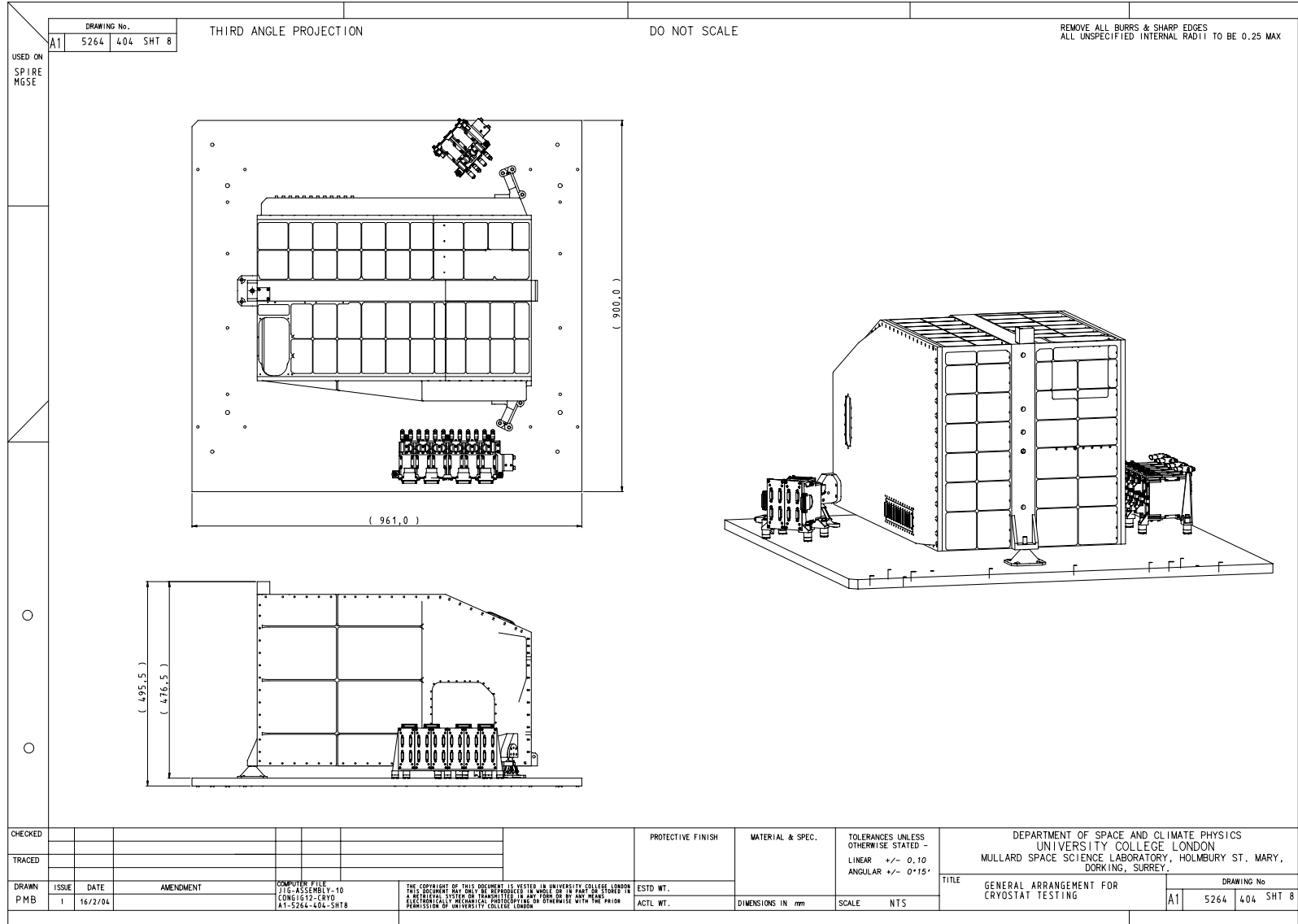

**SPIRE**

**Project Document**

SPIRE FPU Handling and Integration  
Procedure

**Ref:** SPIRE-RAL-PRC-  
001923  
**Issue:** 3  
**Date:** 6/12/04  
**Page:** 34 of 35

**ANNEX B - L0 THERMAL STRAP ASSEMBLY**

# SPIRE

## Project Document

### SPIRE FPU Handling and Integration Procedure

Ref: SPIRE-RAL-PRC-001923

Issue: 3

Date: 6/12/04

Page: 35 of 35

USED ON SPIRE

DRAWING No. 5264 309A

THIRD ANGLE PROJECTION

DO NOT SCALE

REMOVE ALL BURRS & SHARP EDGES / ALL UNSPECIFIED INTERNAL RADII TO BE 0.25 MAX

**DETAIL A**  
EVAPORATOR UPPER STRAP JUNCTION

**DETAIL B**  
TYPICAL FOR SPECTROMETER AND PUMP UPPER STRAP JUNCTION

**SECTION A-A**  
SPEC STRAP TYPICAL FOR PUMP LOWER FIXINGS EXCEPT ITEM 34 MOUNTING BLOCK AND FIXINGS ARE NOT REQUIRED

**SECTION B-B**  
EVAPORATOR STRAP ONLY

**NOTES**

- 1 MAIN PHOT AND SPEC COVERS HAVE BEEN REMOVED FROM ALL VIEWS
- 2 FINAL ASSEMBLY OF ALL PARTS WILL TAKE PLACE AFTER COMPRESSION AND EB WELDING OF FLEXIBLE STRAPS HAS BEEN COMPLETED
- 3 USE THIS DRAWING IN CONJUNCTION WITH THE EB WELDING FIXTURE A1-5264-PS1 TO FORM FLEXIBLE STRAPS INTO SHAPES SHOWN
- 4 ONLY THE OUTER FLEXIBLE STRAP HAS BEEN SHOWN AT THE LOWER POSITION OF THE SPEC/PUMP/LEAP STRAPS THIS ASSEMBLY REQUIRES BOTH AN INNER AND OUTER LOWER FLEXIBLE STRAP
- 5 ASTRIUM INTERFACE PARTS ARE SHOWN FOR REFERENCE ONLY

QTY	ITEM #	DESCRIPTION	QTY
10	48	washer-M4-oversize	10
24	47	Washer-4-40-oversize	24
12	46	Washer-0-80-small	12
24	45	Washer-4-40 plain	24
15	44	Washer bush	15
1	43	upper-flex-spec-pmb	1
1	42	upper-flex-pump-pmb	1
1	41	upper-flex-evaporator-pmb	1
6	40	Stud	6
12	39	A3-5264-309-6 special washer	12
1	38	SCR-4420L-SKT-C50-40	1
4	37	SCR-4420L-SKT-BUTT-40	4
3	36	Pressure-plate-Astrium	3
3	35	A3-5264-309-1A Outer-baffle-com	3
30	34	Nut 4-40 keylock	30
1	33	Mounting-block	1
15	32	M4-B-32 Keylock nut	15
14	31	M4 washer	14
10	30	M4 Skt Hd bolt 20Lg	10
1	29	lower-flex-spec-outer-pmb	1
1	28	lower-flex-pump-outer-pmb	1
1	27	lower-flex-evaporator-outer-pmb	1
3	26	level-0-coldtrap-spec-pmb2	3
3	25	level-0-coldtrap-pump-pmb	3
1	24	level-0-coldtrap-evaporator-outer	1
2	23	level-0-coldtrap-evaporator-inner	2
4	22	joining-plate-pump-assy	4
1	21	joining-plate-evaporator-outer	1
1	20	joining-plate-evaporator-inner	1
4	19	DOWN-18L-40	4
4	18	ColdTrapSupport-diagonal-leg	4
1	17	ColdTrapSupport-Aspect-diagonal-leg	1
3	16	Cold-Trap-Support-upper	3
3	15	Cold-Trap-Support-diagonal	3
12	14	Cold-Trap-Support-Leg	12
4	13	Crimp	4
4	12	A3-5264-309-2C	4
12	11	Cap-screw-0-80unc x 6.35 lg	12
40	10	Cap screw 4-40unc x 12.7	40
145	9	Bellville washer 0.7 x 0.83 Dia 9.53 I 0.44	145
79	8	Bellville washer B0250-009-S	79
1	7	Baffle-outer-solid-core-SPECT	1
1	6	Baffle-outer-solid-core	1
3	5	Astrium-thermal-sensor	3
1	4	Astrium-pressure-plate-opod	1
10	3	4-40 unc x 8 ssk hd	10
15	2	4-40 unc x 10 ssk hd	15
4	1	NOT REQ 4-40 UNC Nut	4
		Name	QTY

CHECKED

TRACED

DRAWN

PMB

PROTECTIVE FINISH

MATERIAL & SPEC.

TOLERANCES UNLESS OTHERWISE STATED -  
LINEAR +/- 0.10  
ANGULAR +/- 0°15'

DEPARTMENT OF SPACE AND CLIMATE PHYSICS  
UNIVERSITY COLLEGE LONDON  
MULLARD SPACE SCIENCE LABORATORY, HOLMBURY ST. MARY,  
DORKING, SURREY.

ESTD WT.

ACTL WT.

DIMENSIONS IN mm

SCALE NTS

TITLE LEVEL 0 COLD STRAP ASSEMBLY

DRAWING No

A1 5264 309A