

Definition of Optically Black Surfaces on SPIRE
Douglas Griffin

1. Distribution

Peter Hargrave	Cardiff
Chris Brockley-Blatt	MSSL
Bruce Swinyard	RAL
Marc Ferlet	RAL
Alan Pearce	RAL

2. Issue Record

Issue Number	Date	Notes
Issue 0.1	Friday, 19 September 2003	Initial issue
Issue 0.2	Friday, 19 September 2003 (a bit later)	Figure 3 added
	Monday 29 Sept. 2003	Views of tiles on structure added. (Figures 4 through 7
Issue 0.3		Detailed drawings of two tile types that will be used to qualify the process. (See Appendix Two)
	Tuesday, 18 May 2004	Figures updated
		Tiles renamed
Pre-release 1.0	Thursday, 01 July 2004	Re-issued for comment
Issue 1.0	Friday, 16 July 2004	Added blacking inside S-Cal Box
		Added blacking to SCAL Exit Baffle Ring. See Figure 7, §8.5, page 11
Issue 1.1	Wednesday, 01 December 2004	Corrected swapped labelling of SPZ-01/SPZ-03 in Figure 23, §8.7.1, Page 27.

3. List of Figures

Figure 1 - View of cold stop and mount from inside the Photometer Detector box detailing the surface to be coated with Black.....	5
Figure 2 - Extra details of keep out zone.....	6
Figure 3 - SM12 A/B details	7
Figure 4 - General view of blackened area on SM9A Baffle	8
Figure 5 - Details of blacking to SM9A Baffle	9
Figure 6 - Details of S-Cal Box tile.....	10
Figure 7 - Details of tiles and blacking inside the S-Cal box.....	11
Figure 8 - Section through Photometer Detector Box towards PDic-2	12
Figure 9 - Axial section of Photometer Detector box onto the four tiles on the spine.....	13
Figure 10 - Sectional view of tiles inside Photometer Detector Box.....	14
Figure 11 - General view of tiles mounted on Bottom Cover	15
Figure 12 - Modifications to Photometer Detector Box Bottom Cover for Black tile screws.....	16
Figure 13 - Photometer Detector Box Bottom Cover Tile detailed drawings	17
Figure 14 - General view of Tiles in Spine	18
Figure 15 - Photometer Detector Box SPINE Tile details.....	19
Figure 16 - General view of the Photometer detector box lid with the tile installed.....	20
Figure 17 – Photometer Detector Box Tile location and detail.....	21

Figure 18 – General view of tiles mounted on the plus-Y face of the input baffle	22
Figure 19 - General view of tiles mounted on the minus-Z face of the input baffle	23
Figure 20 - General view of tiles mounted on the minus-Y face of the input baffle.....	24
Figure 21 – General view of tiles mounted on the plus-Z face of the input baffle.....	25
Figure 22 - Two views into SPIRE Input baffle showing clearance between the oversized beams and the tiles.	26
Figure 23 - Identification and positioning of SPZ Tiles	27
Figure 24 – Details of SPZ Face Tiles.....	28
Figure 25 - - Identification and positioning of SMZ Tiles	29
Figure 26 - Details of SMZ Face Tiles.....	30
Figure 27 - Identification and positioning of SPY Face Tiles	31
Figure 28 - Details of SPY Face Tiles.....	32
Figure 29 - Identification and positioning of SMY Face Tiles as well as the CMY Tiles	33
Figure 30 - Details of SMY Face Tiles.....	34
Figure 31 Identification and positioning of CMX Face Tiles.....	35
Figure 32 Identification and positioning of CPZ Face Tiles as well as the details of the CPZ Tiles.	36
Figure 33 – Details of the CMY face tiles.....	37
Figure 34 - Optical Sub-bench tiles.....	38
Figure 35 – Tile with “Kapton handle”	39
Figure 36 - Tile Type 1. Glued on outside cover.....	41
Figure 37 - Tile type 2. Glued on outside cover.....	41

4. Applicable Documents

	Doc Number	Name	Author	Issue	Date
AD 1	HSO-CDF-PR-049	Black Coating (SiC loaded) – BG7B Application	Peter Hargrave	1.0	3 July 2003
AD 2	HSO-CDF-PR-050	Black Coating – BG1 Application Procedure	Peter Hargrave	1.0	29 March 2004
AD3	MSSL- 5264-309	Cooler Strap Joints	John Coker	TBD ¹	TBD

5. Table of Contents

1.	Distribution.....	1
2.	Issue Record	1
3.	List of Figures	1
4.	Applicable Documents	2
5.	Table of Contents	2
6.	Introduction and Scope.....	3
7.	General Tile Requirements.....	3
8.	Blackening Details/Summary.....	4
8.1.	Photometer Cold Stop.....	5
8.2.	SM12 A/B.....	6
8.3.	SM-9A Baffle	7
8.4.	S-Cal Box outer wall	10
8.5.	Interior of S-Cal Box	11
8.6.	Photometer Detector Box	12
8.6.1.	General views.....	12
8.6.2.	General view of Photometer Detector Box Bottom Cover.....	15
8.6.3.	Photometer Detector Box Bottom Cover Tiles (PBB)	16
8.6.4.	Photometer Detector Box SPINE Tiles (PBS)	18

¹ At the time of writing of this document, the details of the blackening needed to be added to this drawing. The issue of the drawing at the time of writing was Issue 7, 13/01/04.

8.6.5.	Photometer Detector Box Top Cover Tile (PBL).....	20
8.7.	Input Baffle (“Snout”) Tiles.....	22
8.7.1.	Input baffle (“Snout”) +Z Face Tiles (SPZ).....	27
8.7.2.	Input baffle (“Snout”) –Z Face Tiles (SMZ).....	29
8.7.3.	Input Baffle (“Snout”) +Y Face Tiles (SPY).....	31
8.7.4.	Input Baffle (“Snout”) –Y Face Tiles (SMY).....	33
8.8.	Cover Tiles.....	35
8.8.1.	Cover -X Face Tiles (CMX).....	35
8.8.2.	Cover +Z Face Tiles (CPZ).....	36
8.8.3.	Cover –Y Face Tiles (CMY).....	37
8.9.	Optical Sub-bench Tiles (OSB).....	38
8.10.	Level-0 Strap Stray-Light Baffles.....	39
9.	Appendix One – Tile Application Procedure.....	39
10.	Appendix Two – Qualification Tiles.....	41

6. Introduction and Scope

A strategy of localized blacking has been adopted to avoid spurious stray-light sources being imaged by the SPIRE detectors. This localized blacking absorbs stray light at surfaces identified as being potential reflection paths for light into the detectors. Two types of Black are to be used as described in AD1 and AD2. The first type is an epoxy resin loaded with grains of SiC applied to tiles which are subsequently secured to flat surfaces of the instrument. The second type of blacking is epoxy loaded with lampblack applied directly to surfaces of the instrument with a brush.

This document is intended to:

- a) Specify the locations on SPIRE that require Black.
- b) Specify the type of Black to be applied at each location
- c) Specify the design of each type of tile.
- d) Document the procedure for applying the tiles to the instrument

7. General Tile Requirements

1. The Black applied within the 1mm deep well in the tile is not to protrude more than 0.5mm above the height of the tile. In other words, the overall height of the tile is not to be more than 2.5mm.
2. The Black is not to extend further than 0.5mm from the edge of the well
3. After the tile has been applied to the surface of the instrument and the adhesive has cured, the electrical resistance between the tile and the chassis of SPIRE is to be measured. If it is greater than 500k Ω , then a conductive adhesive as specified in §9 - Appendix One – Tile Application Procedure is to be used to electrically connect the tile to the chassis of the instrument. This requirement is to ensure that any surface charge generated on the epoxy is discharged to S/C chassis.

8. Blacking Details/Summary

Location on Instrument	Type of Blacking	Reference	Mass w/o ¹ Black	Number off	Area (mm ²)	Estimated Mass ²
On Baffle near SM9A Mirror	Painted	BAFSM9A	NA	1	4560	
Photometer Cover -X Inner face	SiC Tile	CMX-01	4.5 g	2	1341	14.4 g
Photometer Cover -Y Inner face	SiC Tile	CMY-01	5.2 g	2	1581	16.7 g
Photometer Cover +Z Inner face	SiC Tile	CPZ-01	4.5 g	1	1341	7.2 g
Below CM3 on Optical Sub-bench	SiC Tile	OSB-01	3.6 g	1	1061	5.8 g
		OSB-02	3.4 g	1	985	5.4 g
Phot Box Bottom Cover	SiC Tile	PBB-01	14.0 g	1	1839	17.7 g
		PBB-02	14.0 g	1	1841	17.7 g
		PBB-03	3.4 g	1	978	5.4 g
		PBB-04	2.2 g	1	592	3.4 g
		PBB-05	3.4 g	1	910	5.2 g
		PBB-06	3.6 g	1	1060	5.7 g
Phot. Box Lid	SiC Tile	PBL-01	8.6 g	1	1038	10.7 g
Photometer Detector Box Spine	SiC Tile	PBS-01	5.1 g	2	1555	16.4 g
		PBS-02	5.9 g	1	1835	9.5 g
		PBS-03	3.8 g	1	1115	6.1 g
Photometer Cold Stop	Painted	PCS	NA	1	1286	
S-Cal Box outer wall	SiC Tile	SCB-01	5.5 g	1	1694	8.9 g
S-Cal Box interior wall behind SM8	SiC Tile	SCB-02	2.92g	2	792	9.0 g
S-Cal Box Interior	Painted	SCB	NA	1	4497	9.0 g
Det Box Level-0 Strat-Light Baffle	Painted	SLB	NA	3	TBD	
SM 12A	Painted	SM12A	NA	1	1094	
SM12B	Painted	SM12B	NA	1	1094	
Input Baffe Minus Y Face	SiC Tile	SMY-01	3.5 g	1	1035	5.6 g
		SMY-02	3.6 g	7	1039	39.4 g
		SMY-03	3.1 g	1	898	4.9 g
		SMY-04	4.1 g	1	1212	6.5 g
Input Baffle Minus Z face	SiC Tile	SMZ-01	4.8 g	12	1434	91.6 g
Input Baffe Plus Y Face	SiC Tile	SPY-01	4.0 g	1	1208	6.5 g
		SPY-02	4.0 g	1	1208	6.5 g
		SPY-03	4.2 g	6	1249	40.2 g
		SPY-04	3.0 g	1	839	4.7 g
		SPY-05	4.3 g	1	1271	6.8 g
Input Baffle Plus Z Face	SiC Tile	SPZ-01	6.2 g	6	1920	60.2 g
		SPZ-02	7.3 g	1	2283	11.9 g
		SPZ-03	3.9 g	6	1136	36.8 g
		SPZ-04	1.7 g	1	386	2.5 g
					Total estimate	498.2 g

Key:

Acronym	Tile Location
CMX	Instrument Cover, <u>Minus-X</u> Face
CMY	Instrument Cover, <u>Minus-Y</u> Face
CPZ	Instrument Cover, <u>Plus-Z</u> Face
OSB	<u>Optical Sub-Bench</u>
PBB	<u>Photometer Detector Box Bottom</u>
PBL	<u>Photometer Detector Box Lid</u>
PBS	<u>Photometer Detector Box Spine</u>
SCB	<u>S-Cal Box Wall</u>
SMY	Input Baffle (Snout) <u>Minus-Y</u> Face
SMZ	Input Baffle (Snout) <u>Minus-Z</u> Face
SPY	Input Baffle (Snout) <u>Plus-Y</u> Face
SPZ	Input Baffle (Snout) <u>Plus-Z</u> Face

¹ Does not include the mass of any fasteners.

² Based on an assumed density of 2000kg/m³ of the SiC loaded epoxy.

8.1. Photometer Cold Stop

Areas to be blackened indicated by Magenta hatching.

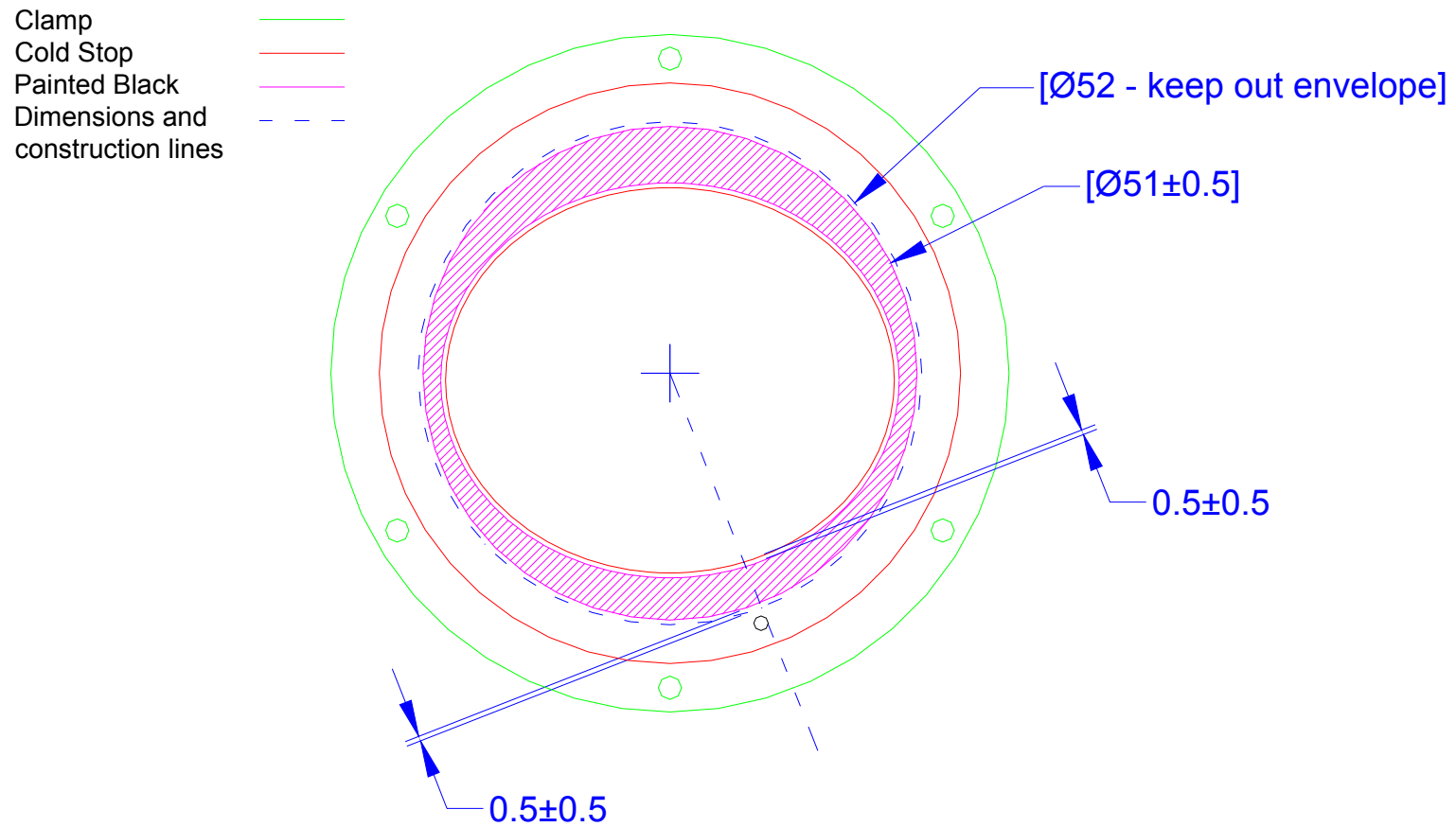
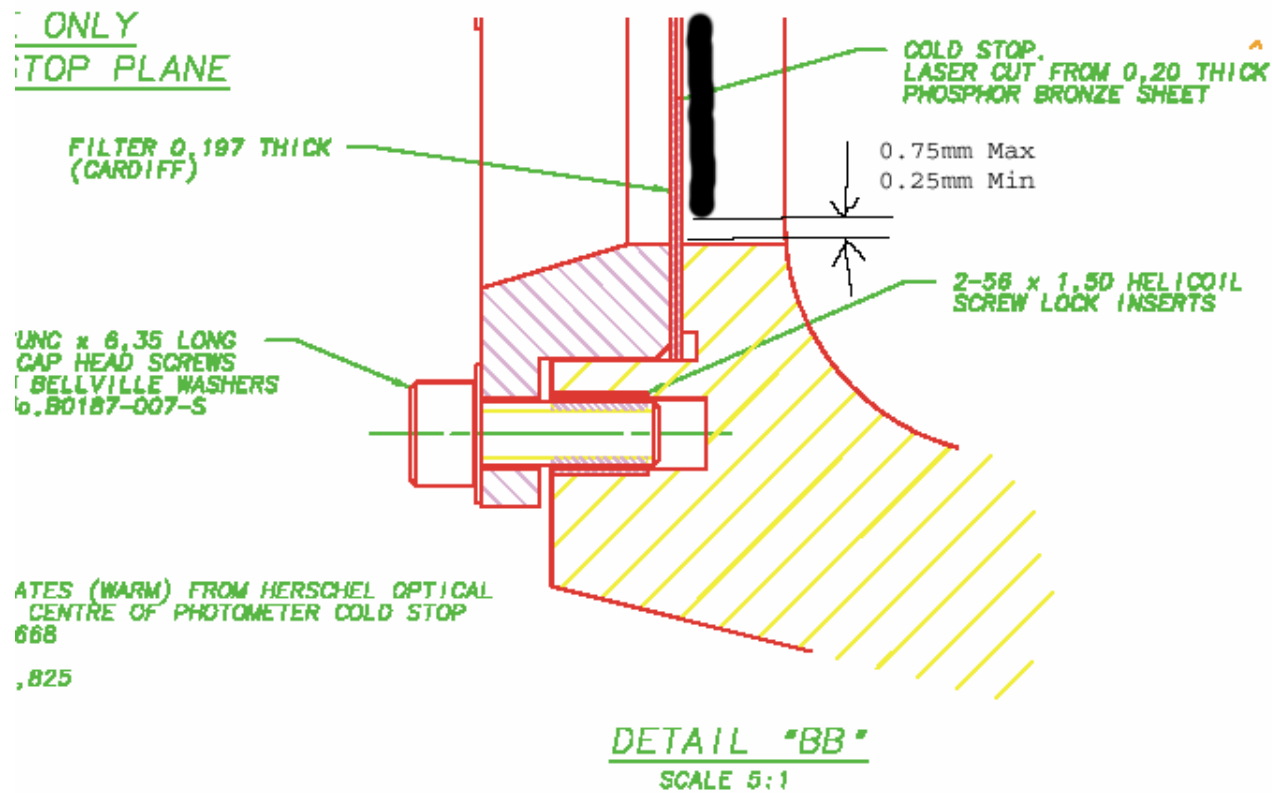

Figure 1 - View of cold stop and mount from inside the Photometer Detector box detailing the surface to be coated with Black.



DEPARTMENT OF SPACE AND CLIMATE PHYSICS
UNIVERSITY COLLEGE LONDON
MULLARD SPACE SCIENCE LABORATORY, HOLMBURY ST. MARY

Figure 2 - Extra details of keep out zone.

8.2. SM12 A/B

Areas to be blackened indicated by Magenta hatching.

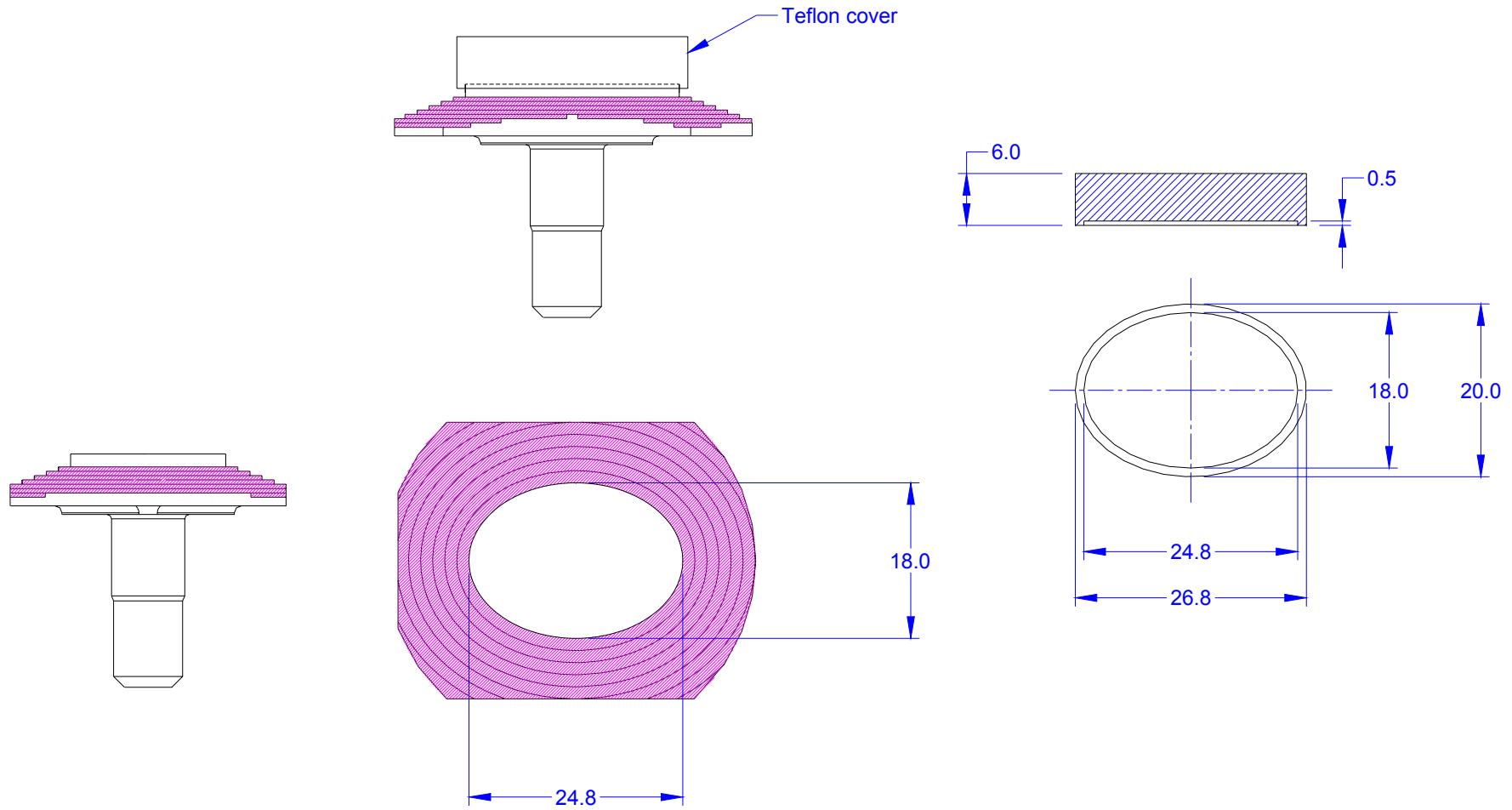

Figure 3 - SM12 A/B details

8.3. SM-9A Baffle

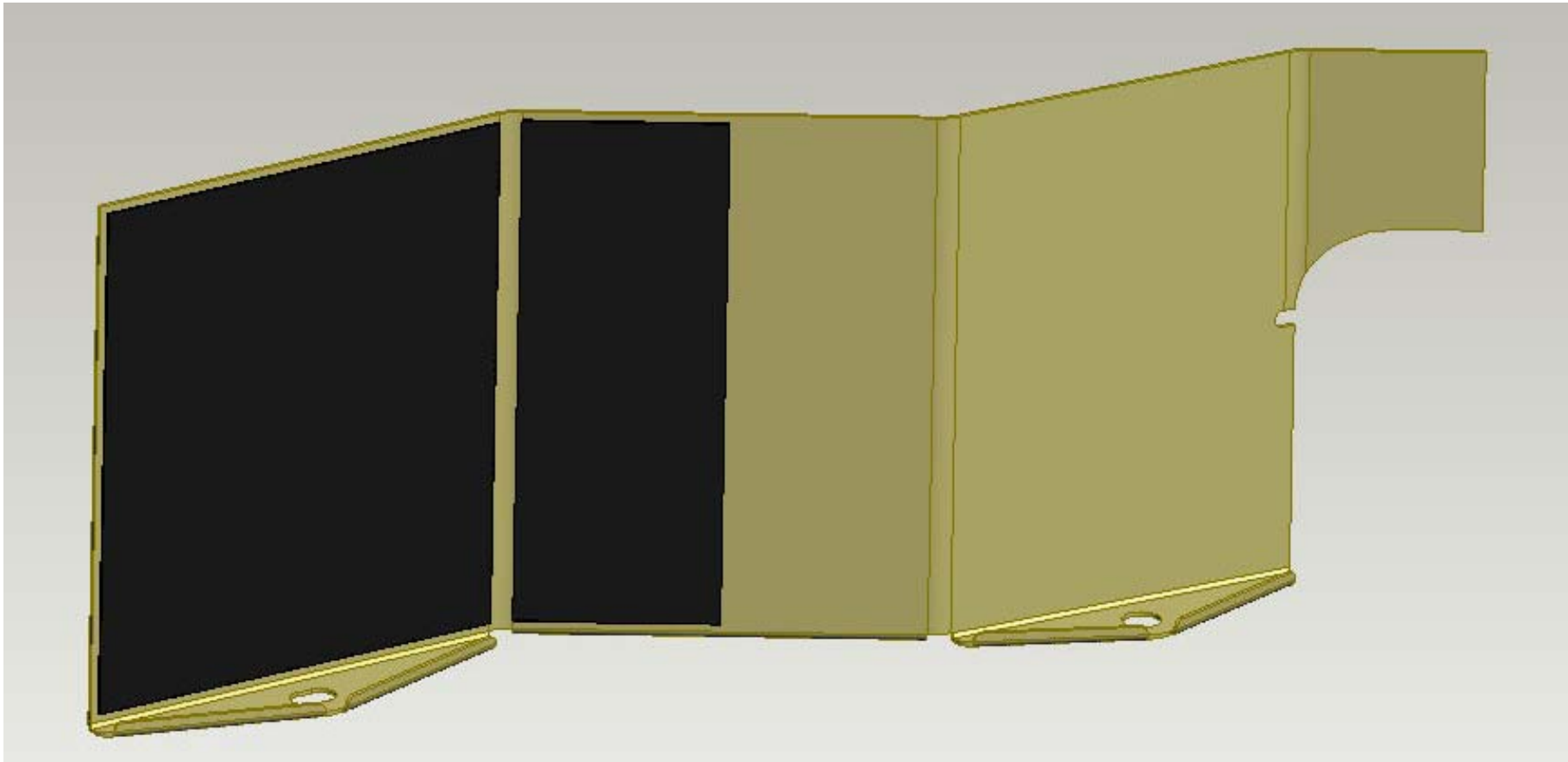

Figure 4 - General view of blackened area on SM9A Baffle

Painted Black to be applied to areas indicated in Figure 5.

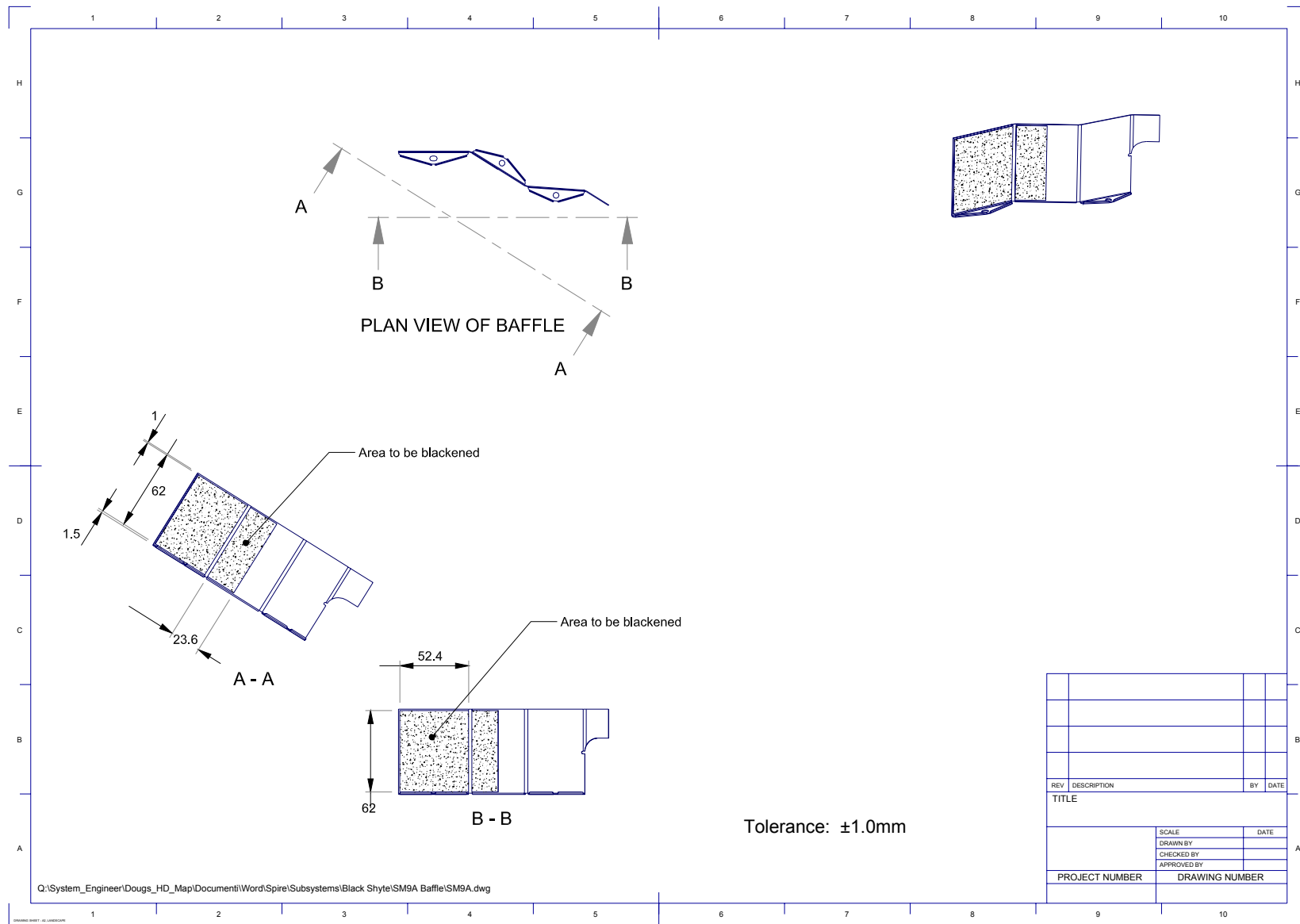

Figure 5 - Details of blacking to SM9A Baffle

8.4. S-Cal Box outer wall

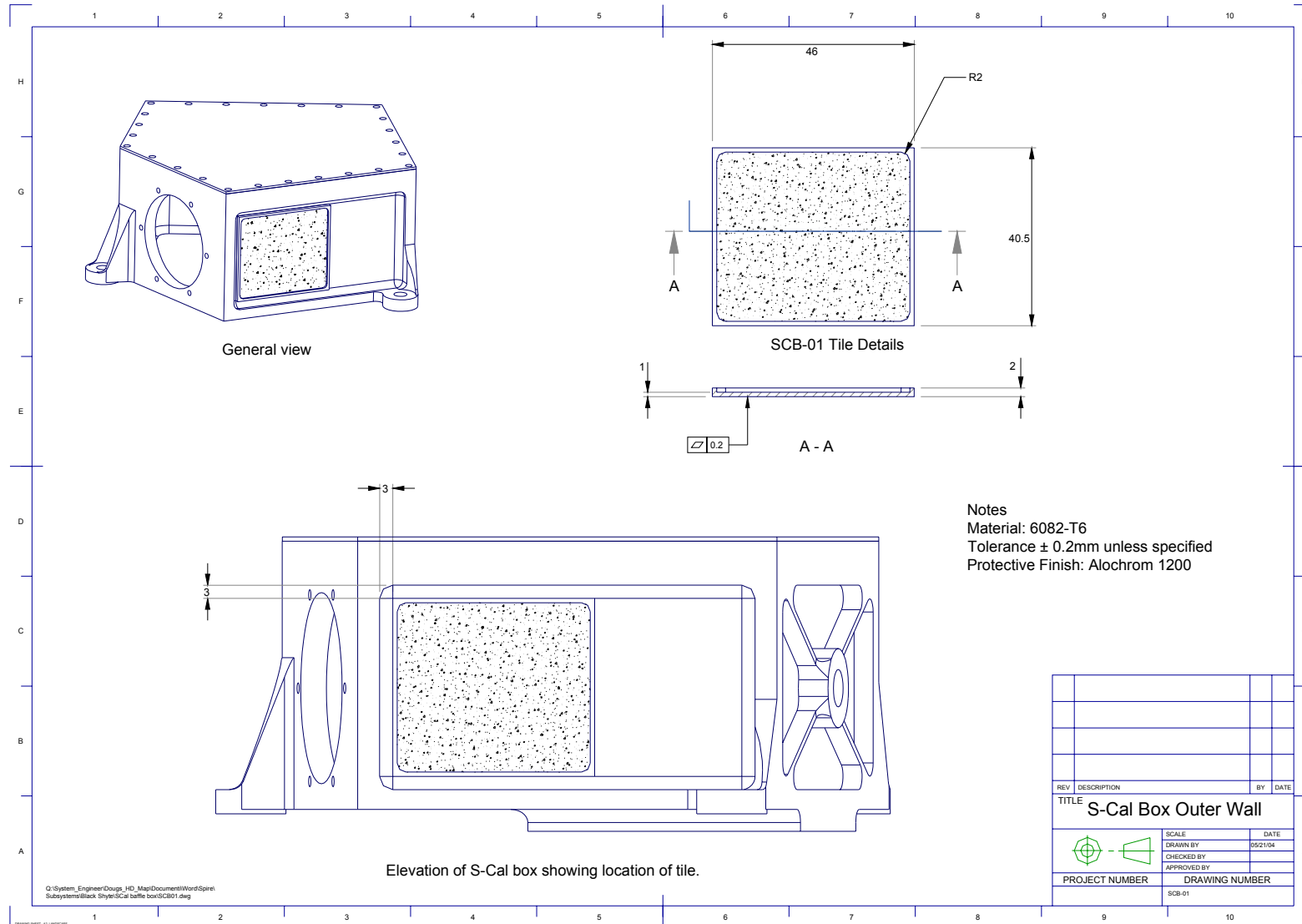

Figure 6 - Details of S-Cal Box tile.

8.5. Interior of S-Cal Box

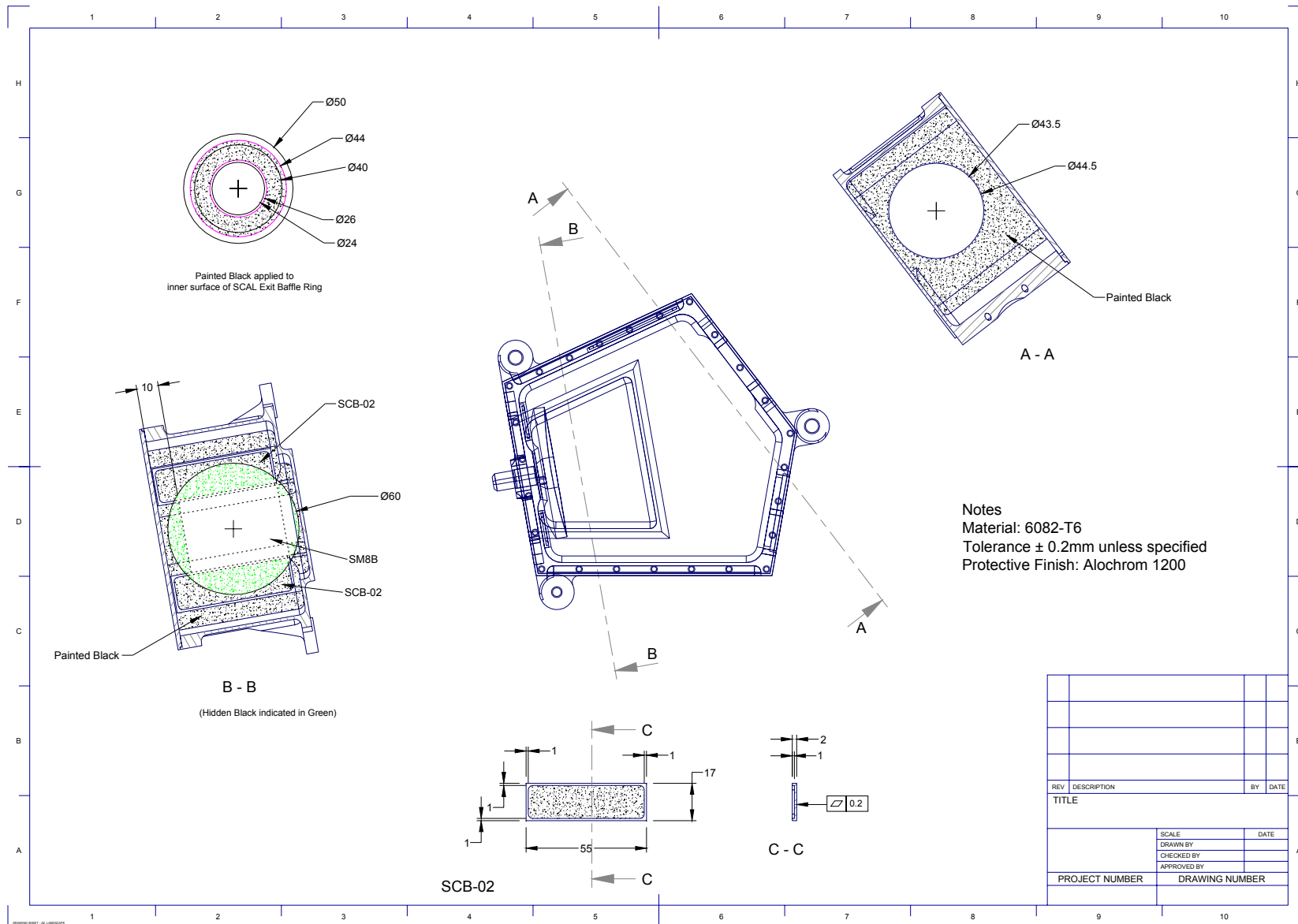

Figure 7 - Details of tiles and blacking inside the S-Cal box.

8.6. Photometer Detector Box

8.6.1. General views

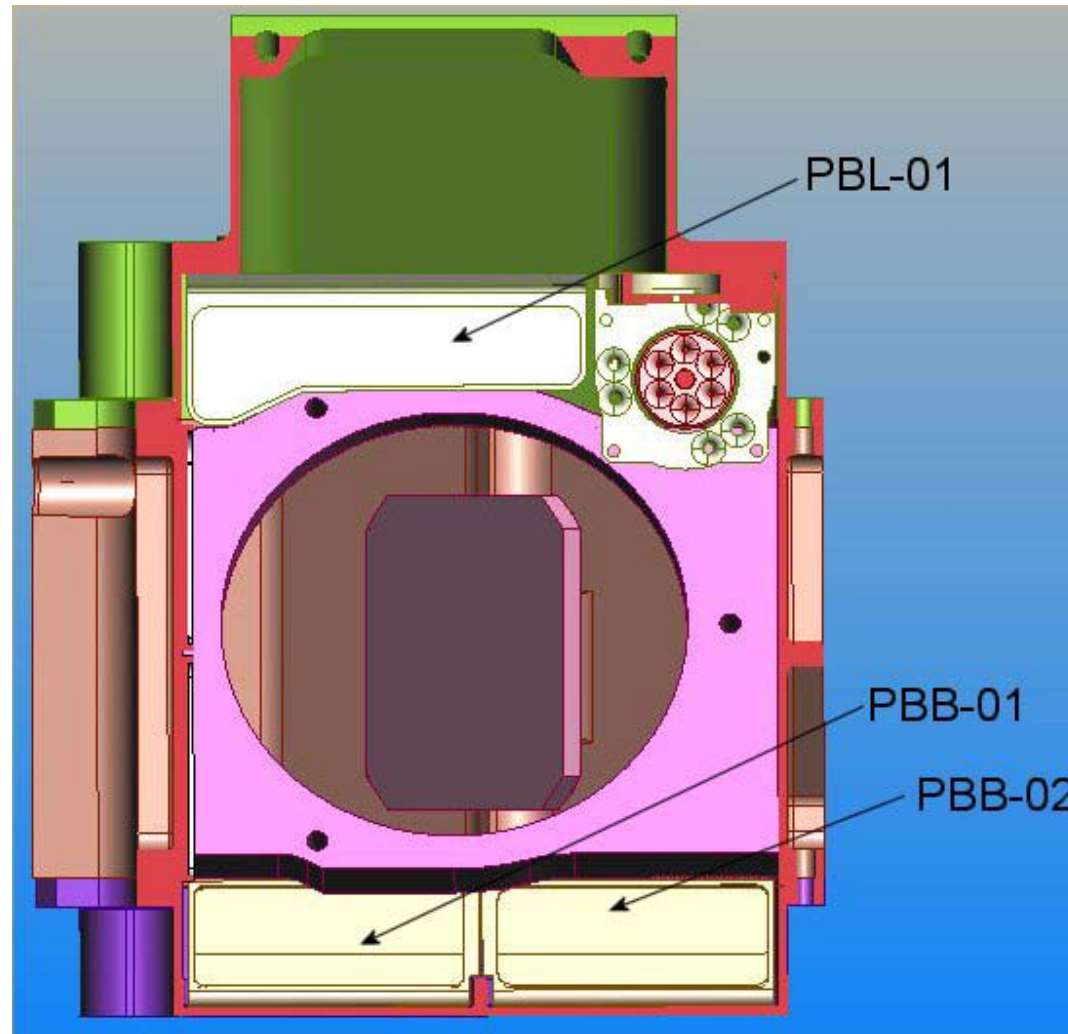

Figure 8 - Section through Photometer Detector Box towards PDic-2

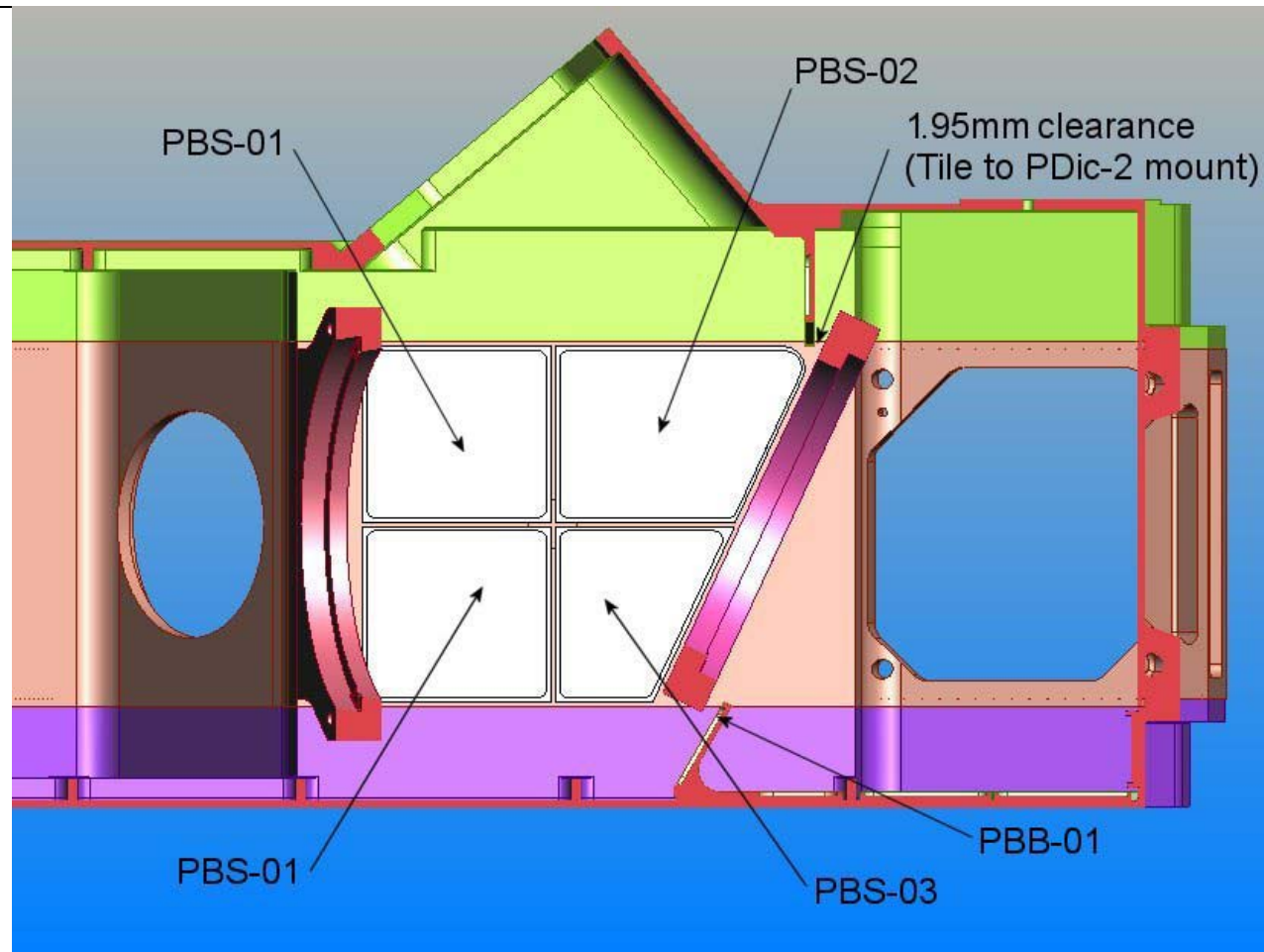

Figure 9 - Axial section of Photometer Detector box onto the four tiles on the spine.

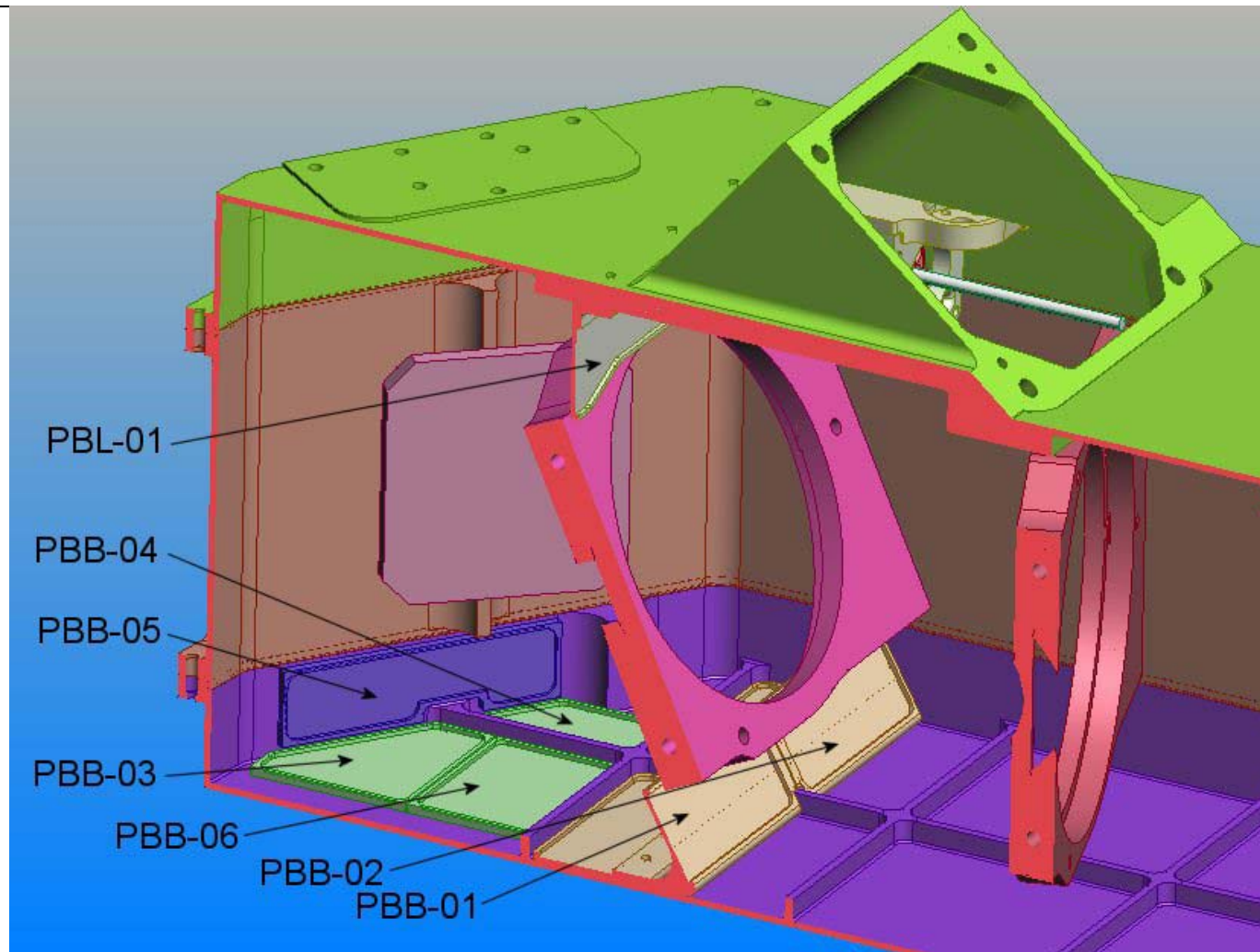

Figure 10 - Sectional view of tiles inside Photometer Detector Box

8.6.2. General view of Photometer Detector Box Bottom Cover

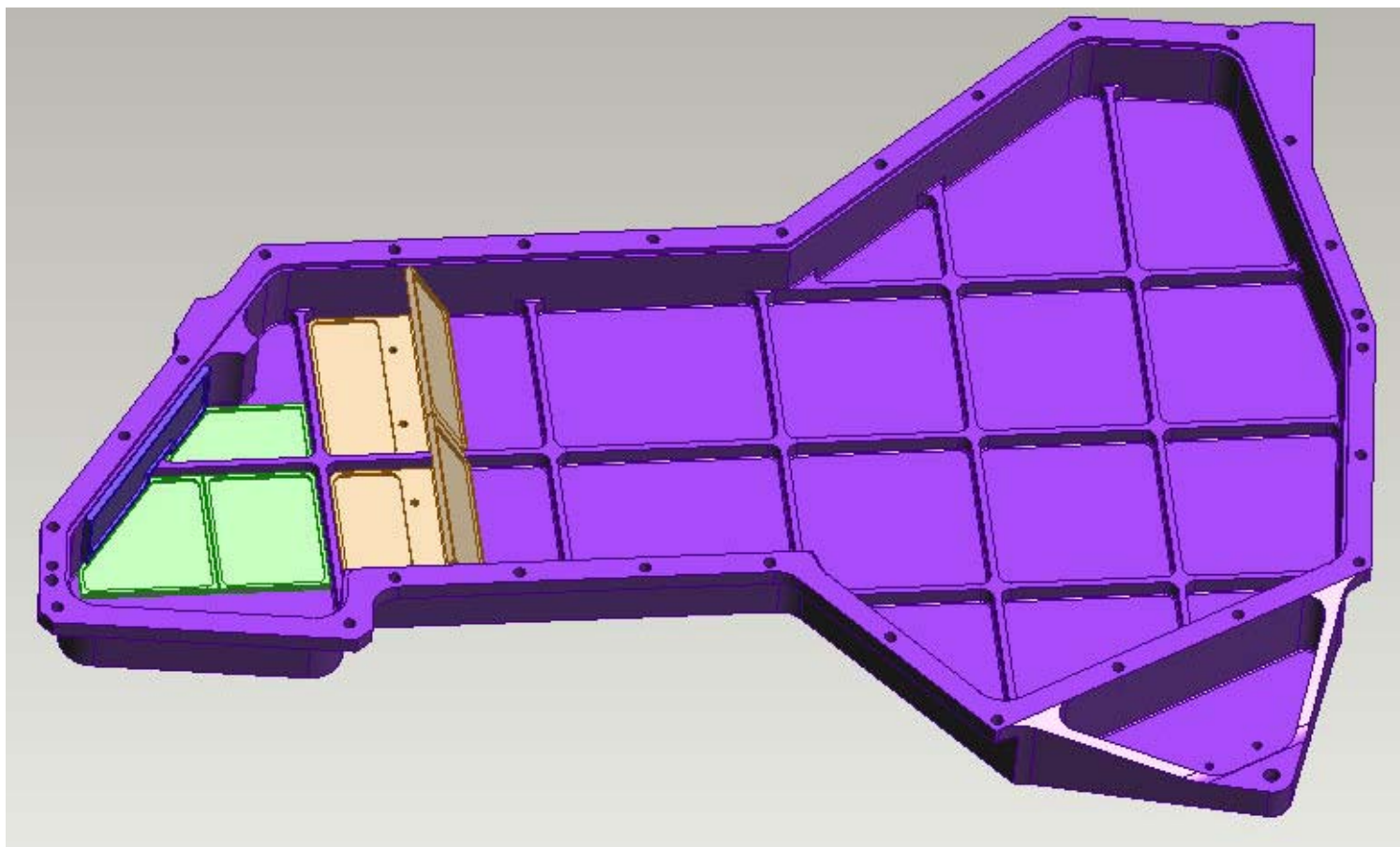

Figure 11 - General view of tiles mounted on Bottom Cover

8.6.3. Photometer Detector Box Bottom Cover Tiles (PBB)

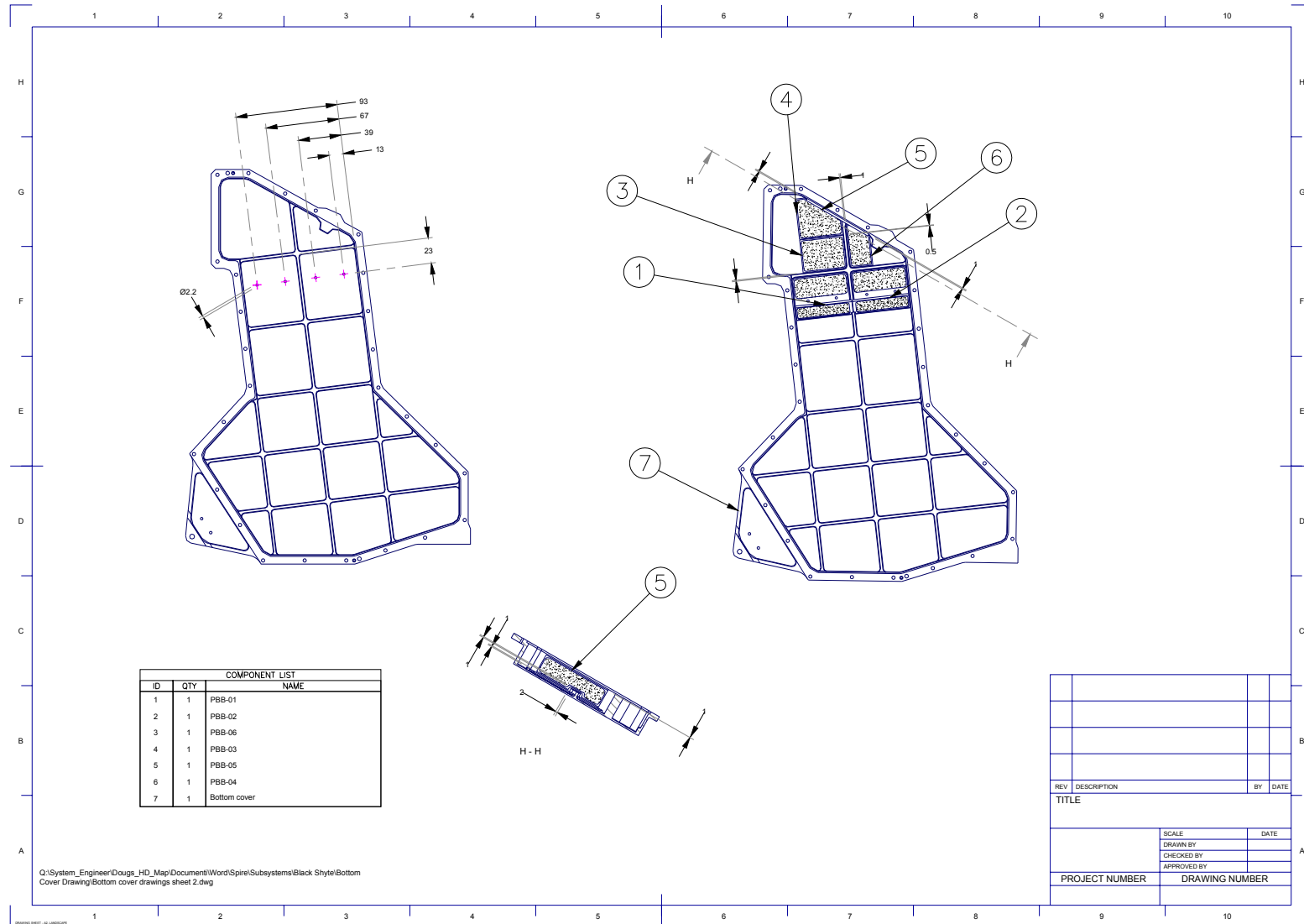

Figure 12 - Modifications to Photometer Detector Box Bottom Cover for Black tile screws.

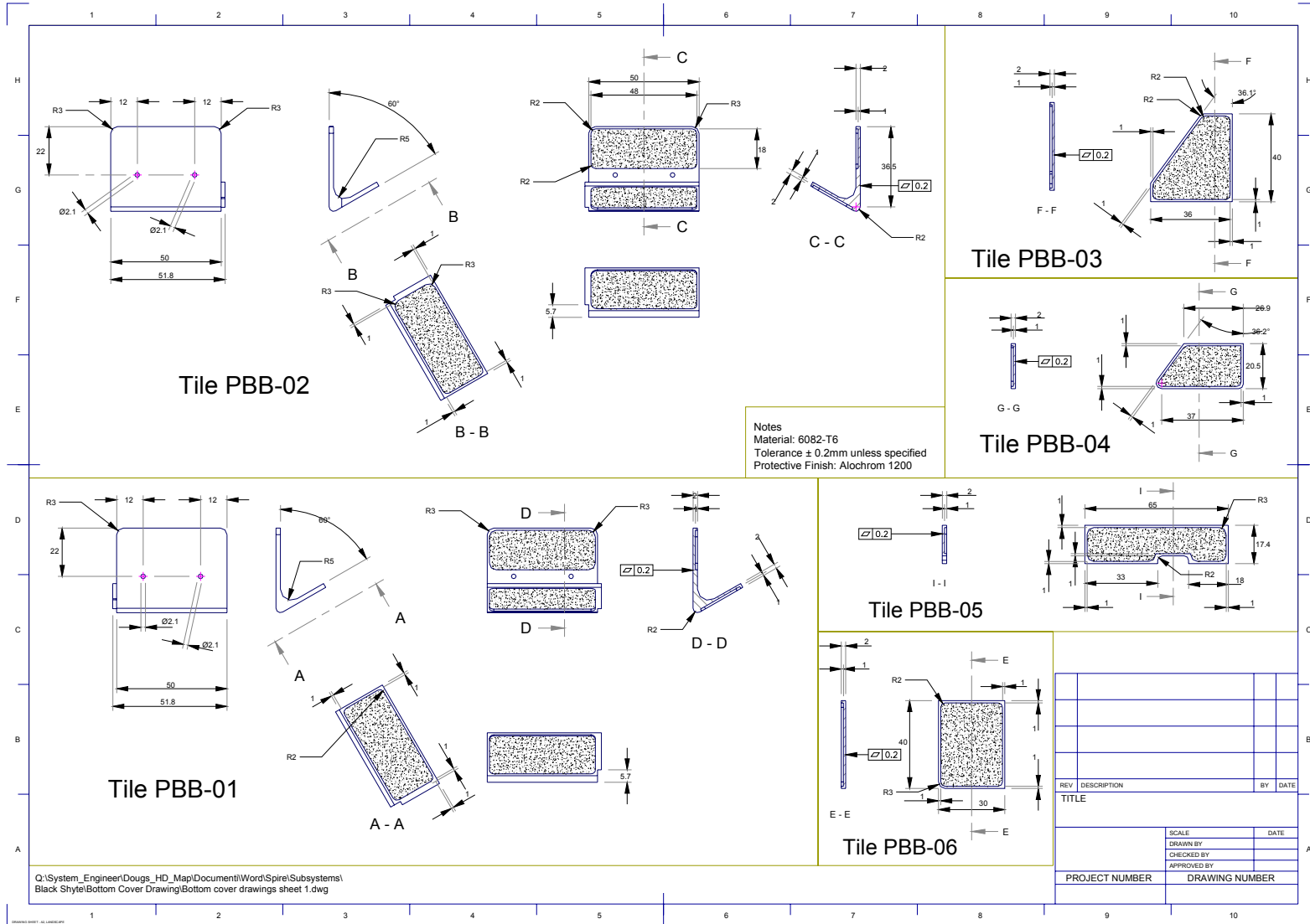

Figure 13 - Photometer Detector Box Bottom Cover Tile detailed drawings

8.6.4. Photometer Detector Box SPINE Tiles (PBS)

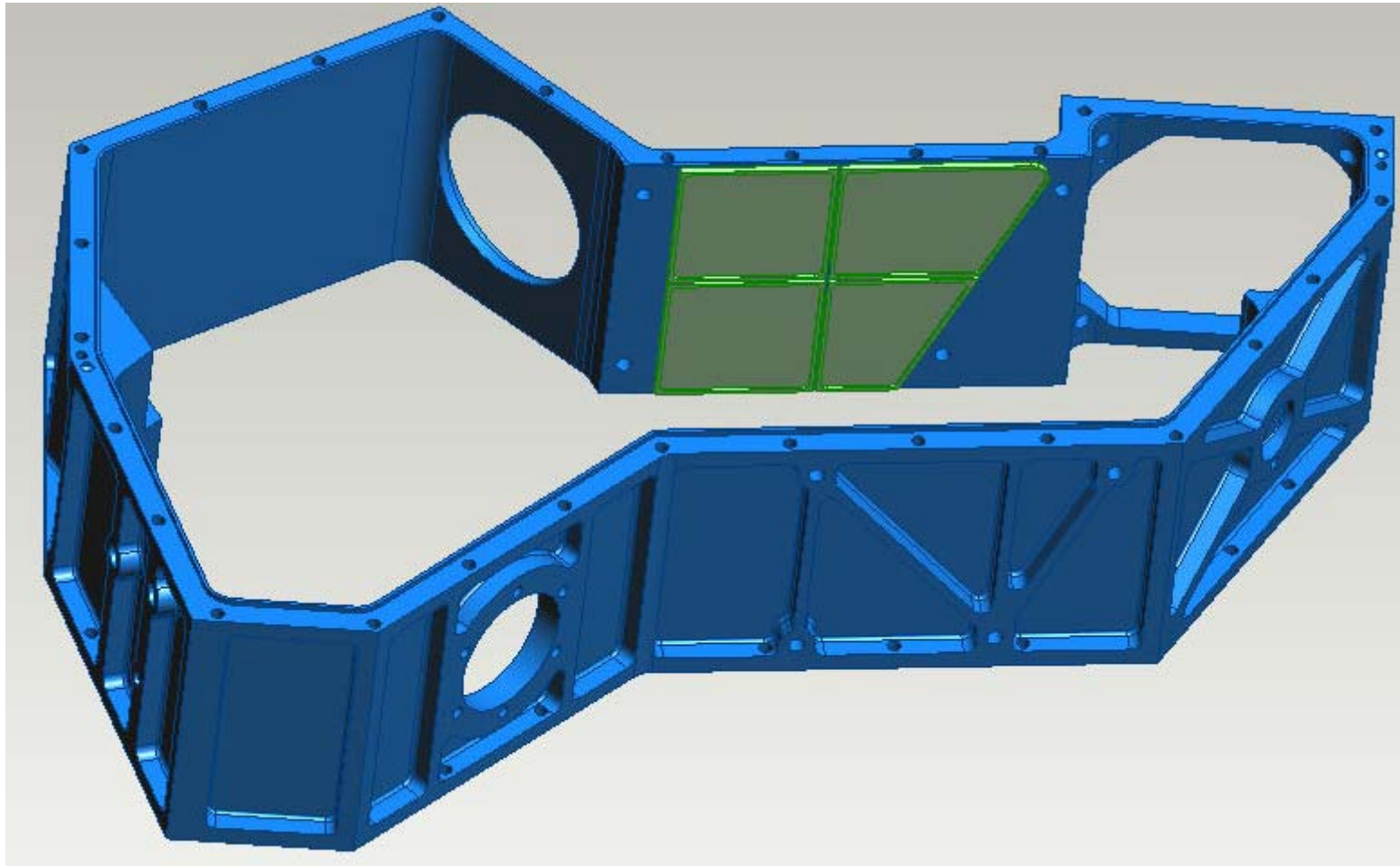

Figure 14 - General view of Tiles in Spine

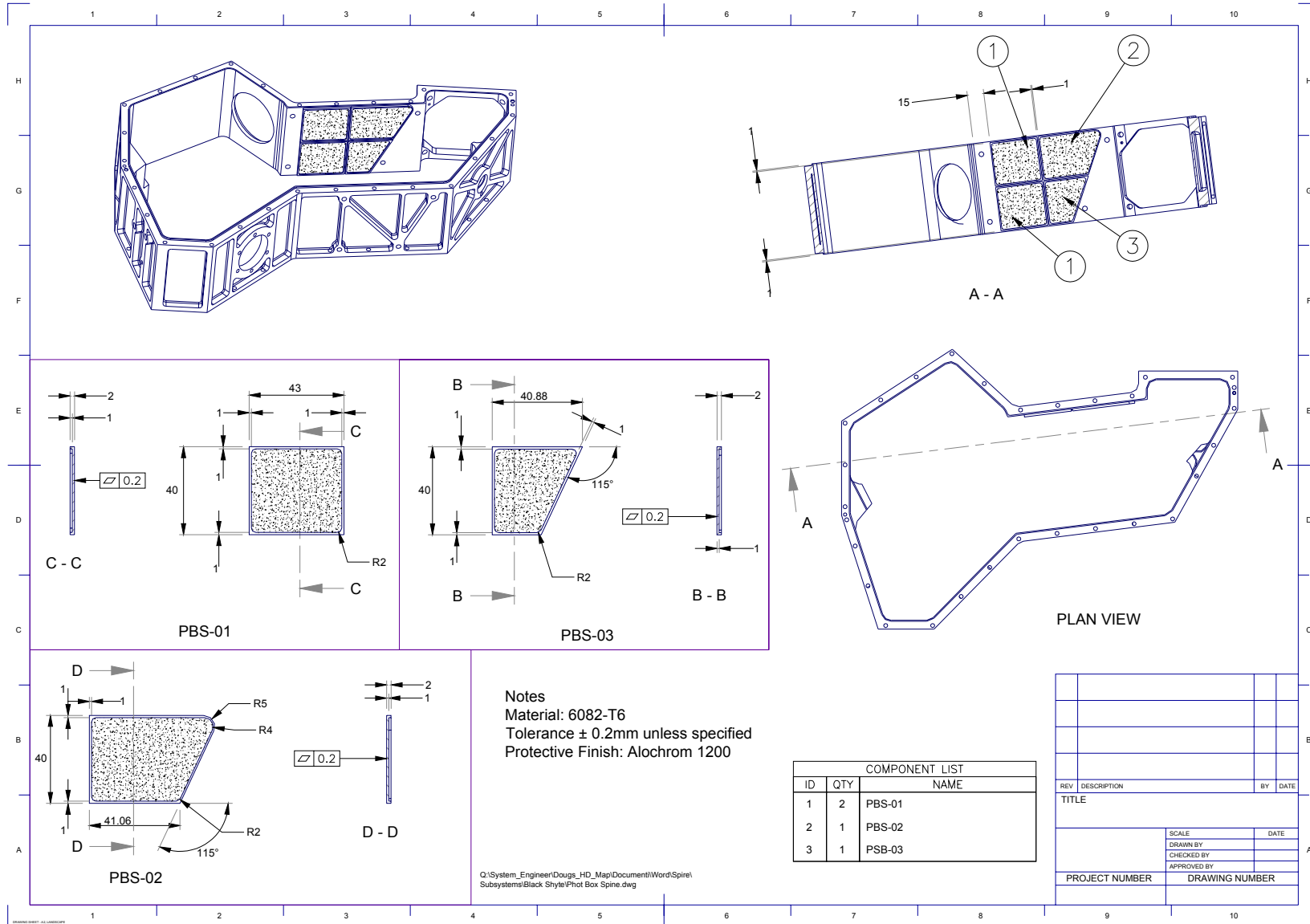

Figure 15 - Photometer Detector Box SPINE Tile details.

8.6.5. Photometer Detector Box Top Cover Tile (PBL)

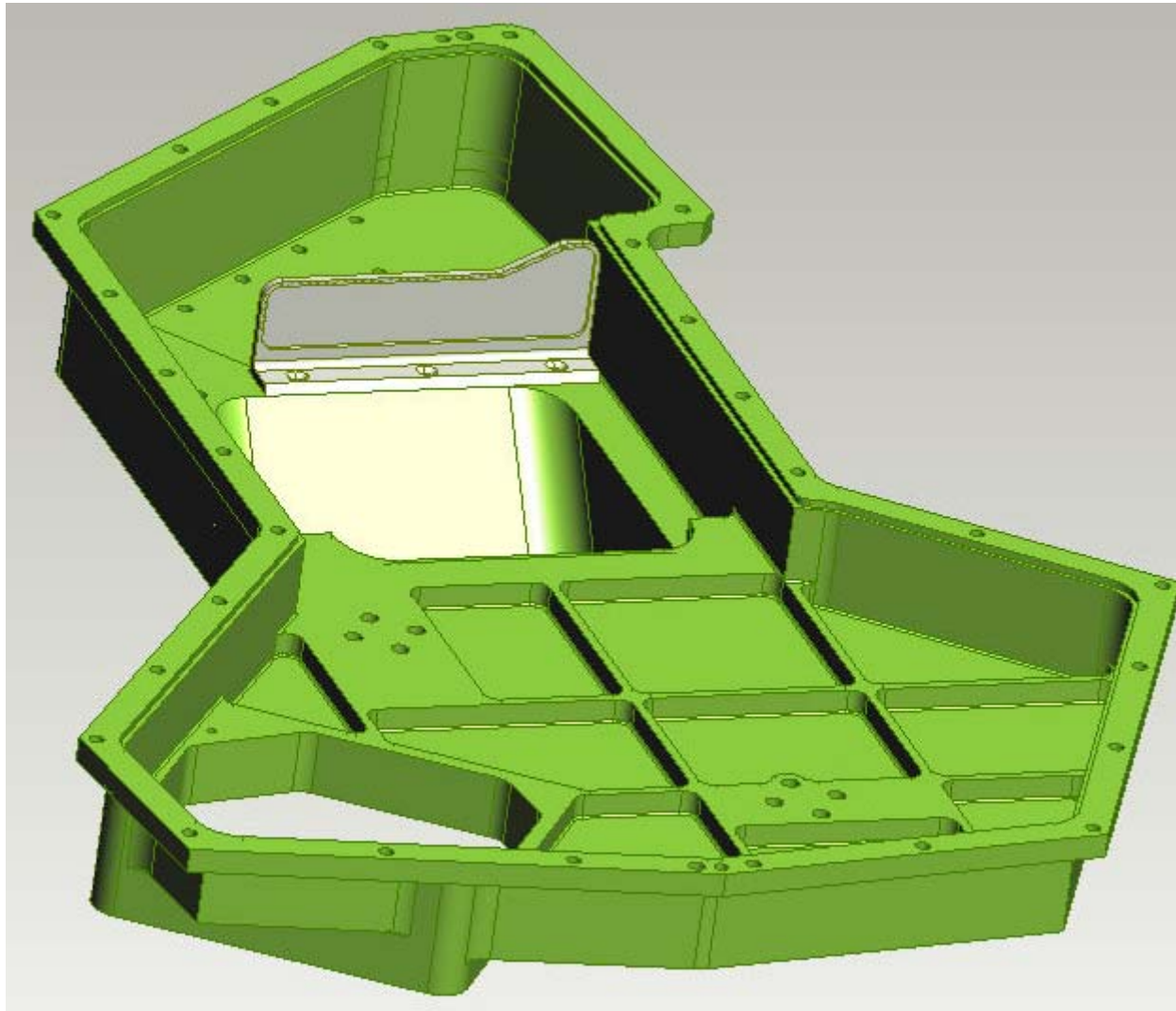

Figure 16 - General view of the Photometer detector box lid with the tile installed.

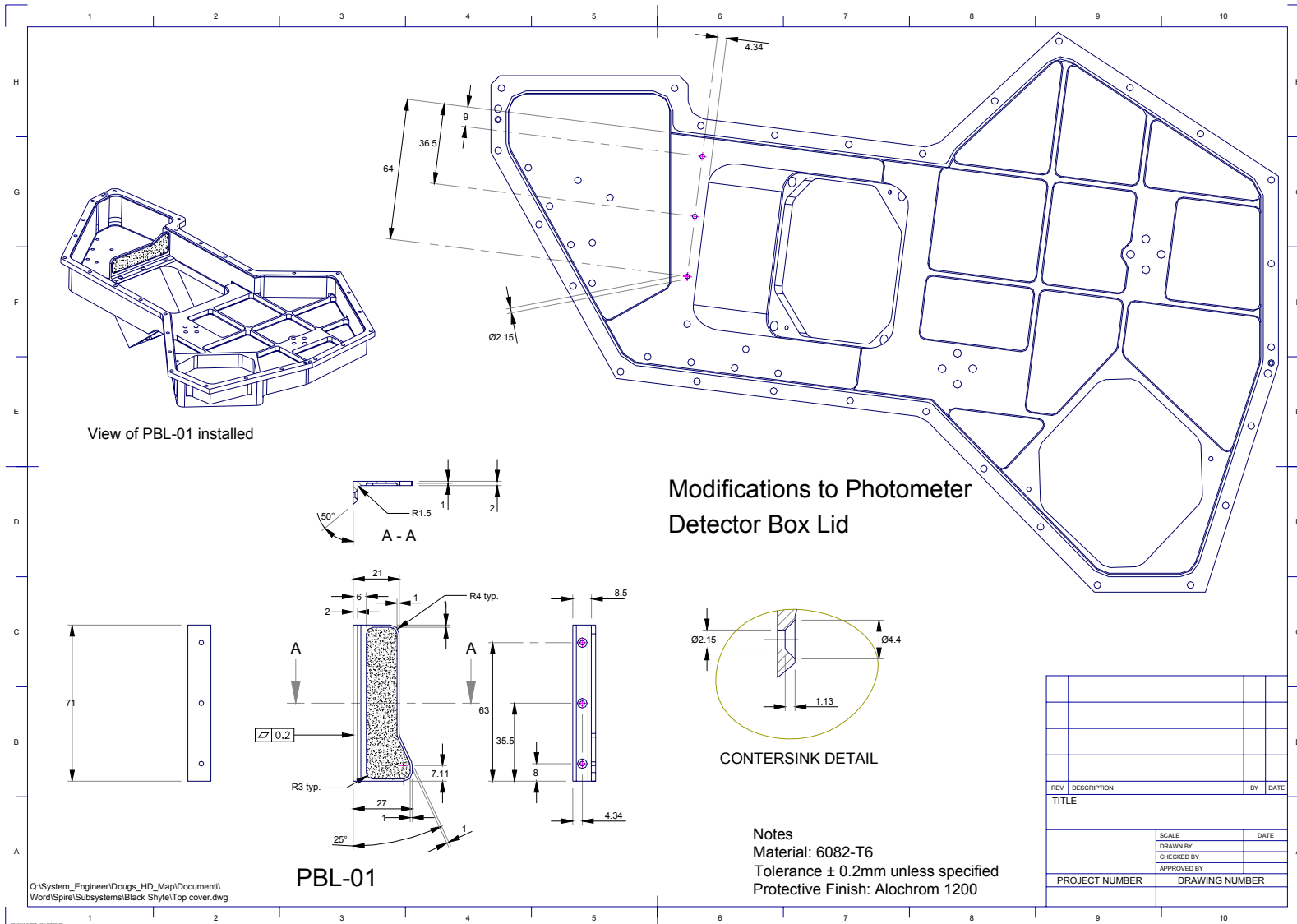

Figure 17 – Photometer Detector Box Tile location and detail.

8.7. Input Baffle (“Snout”) Tiles

There are seven groups of tiles inside the input baffle and around CM3 to absorb stray light. The location of these seven faces is indicated in Figure 18 through Figure 21. Figure 22 shows two views of the clearance between the “oversized” optical beams and the tiles.

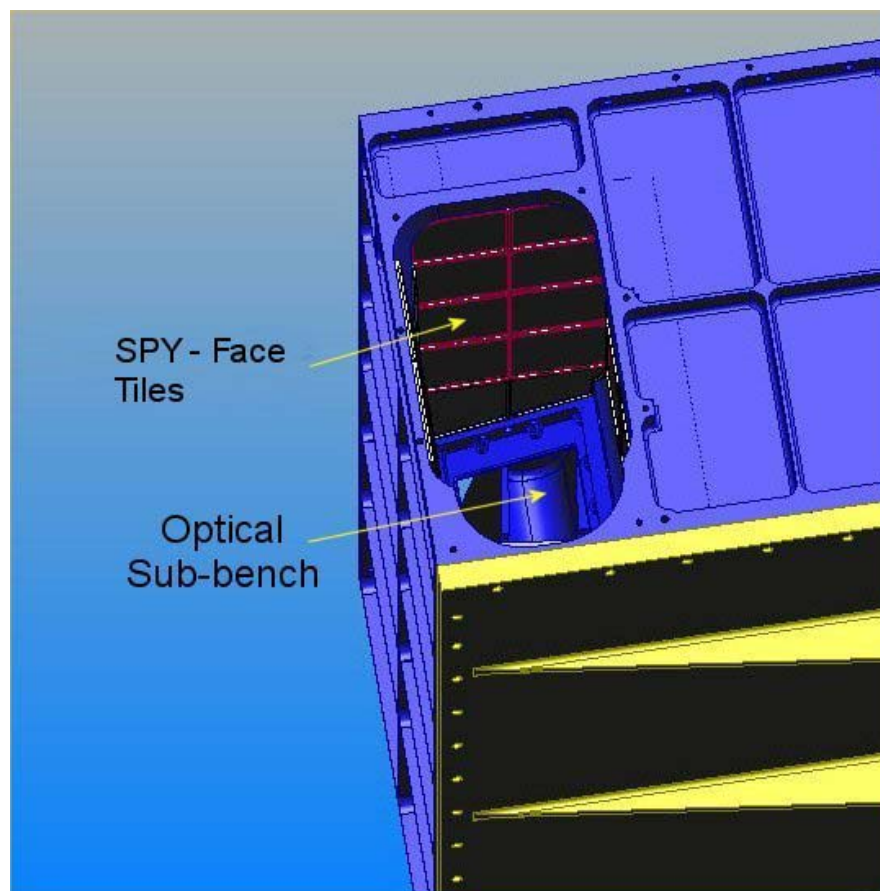

Figure 18 – General view of tiles mounted on the plus-Y face of the input baffle.

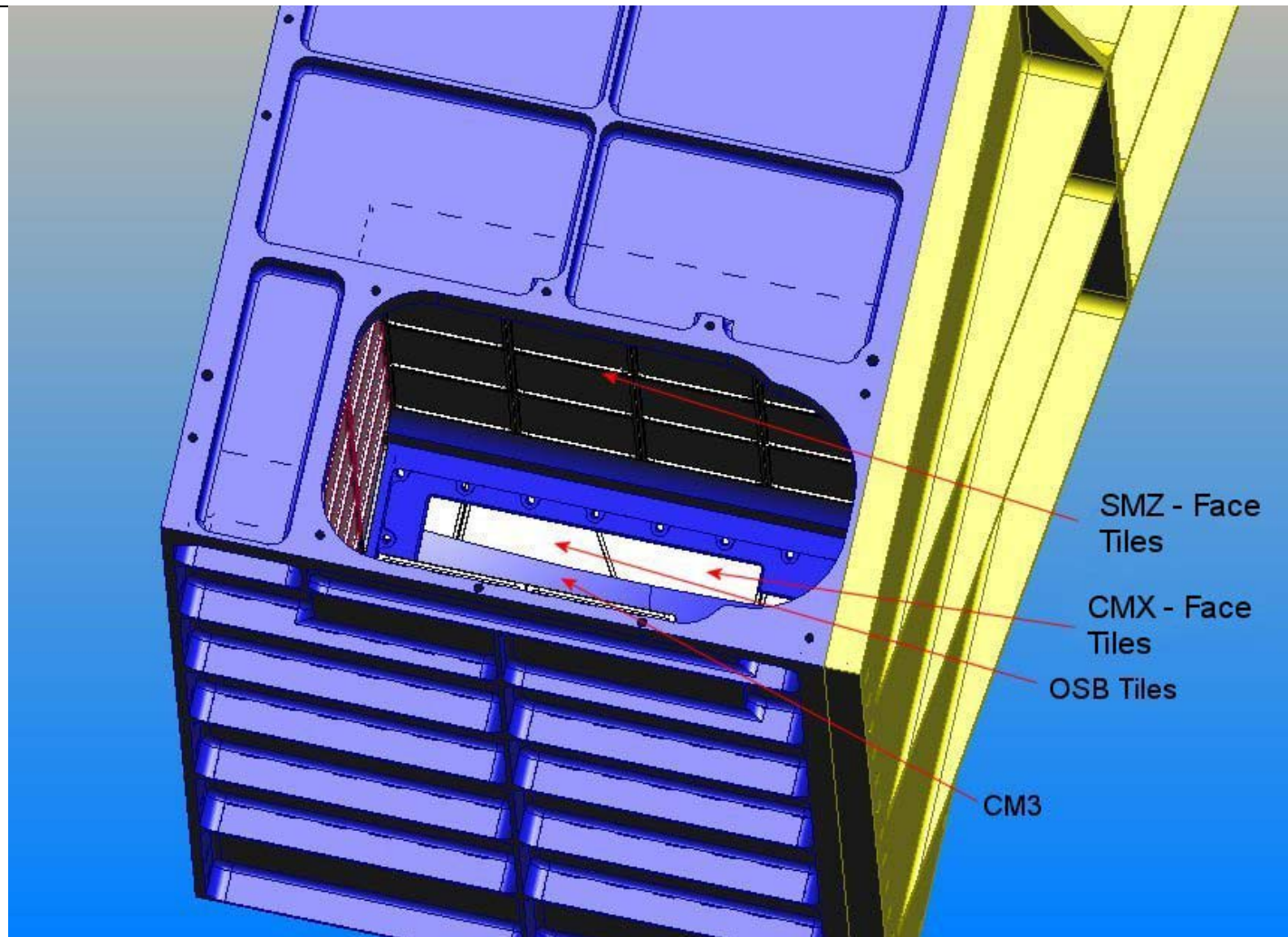

Figure 19 - General view of tiles mounted on the minus-Z face of the input baffle

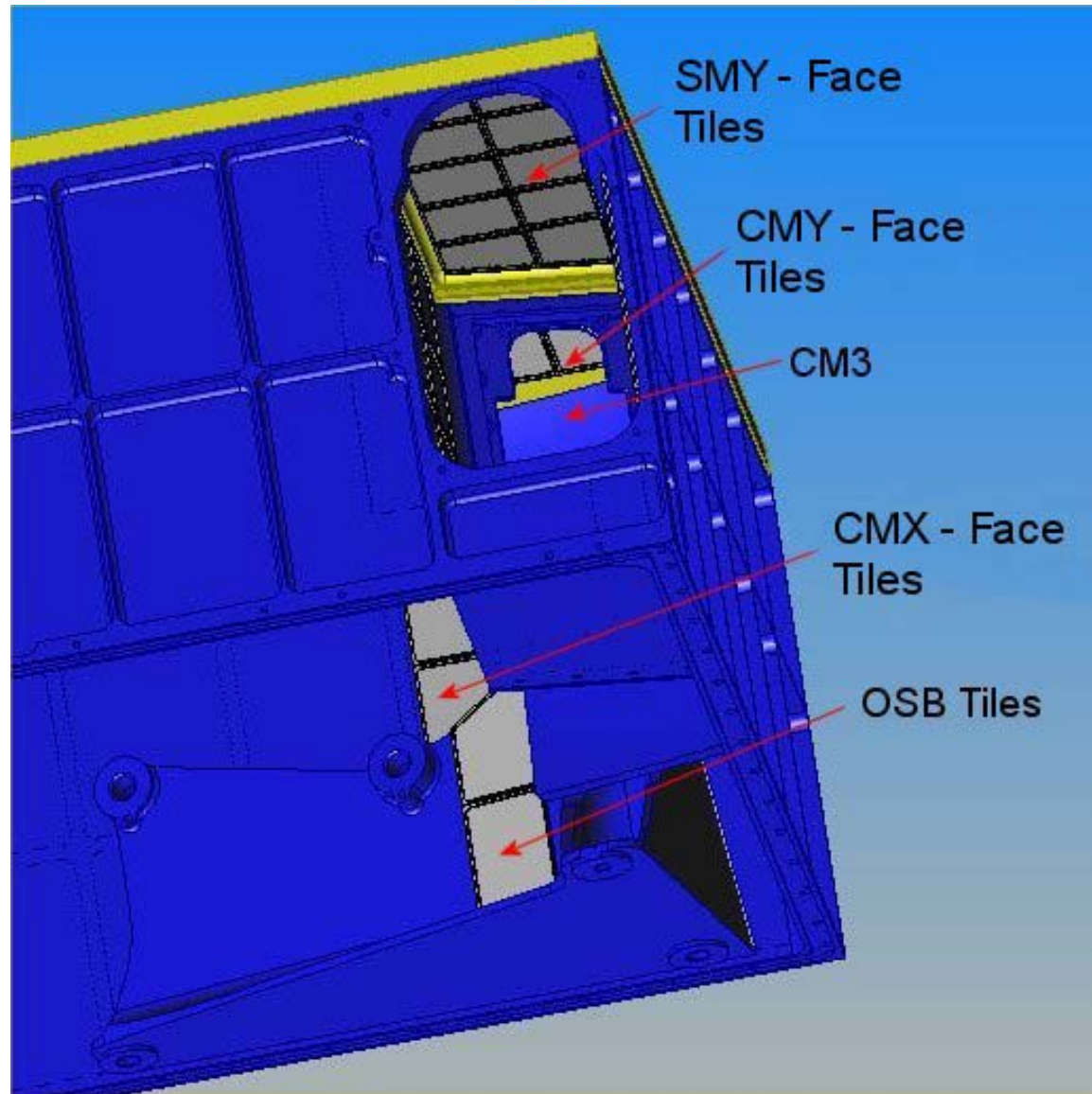

Figure 20 - General view of tiles mounted on the minus-Y face of the input baffle

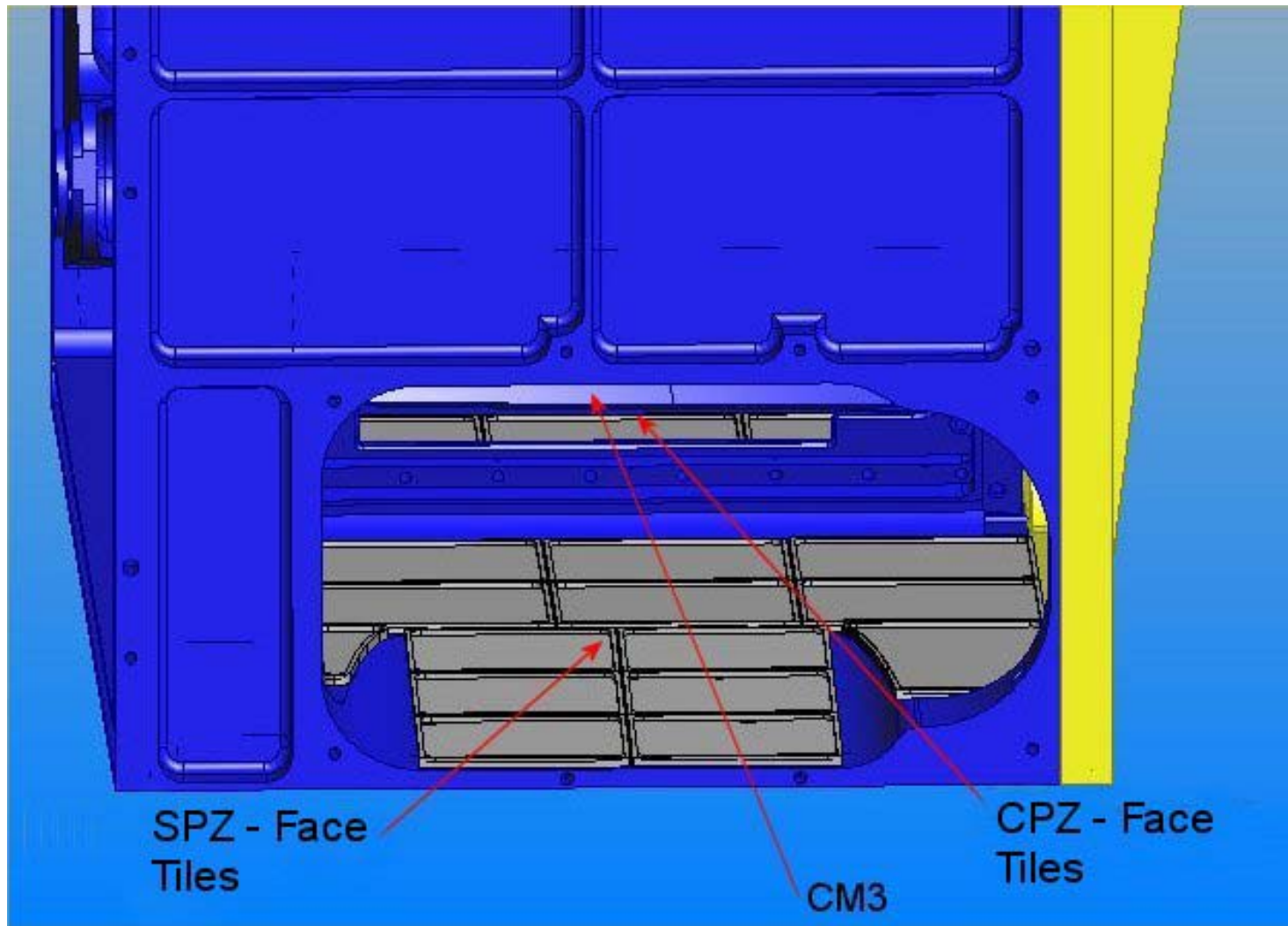

Figure 21 – General view of tiles mounted on the plus-Z face of the input baffle

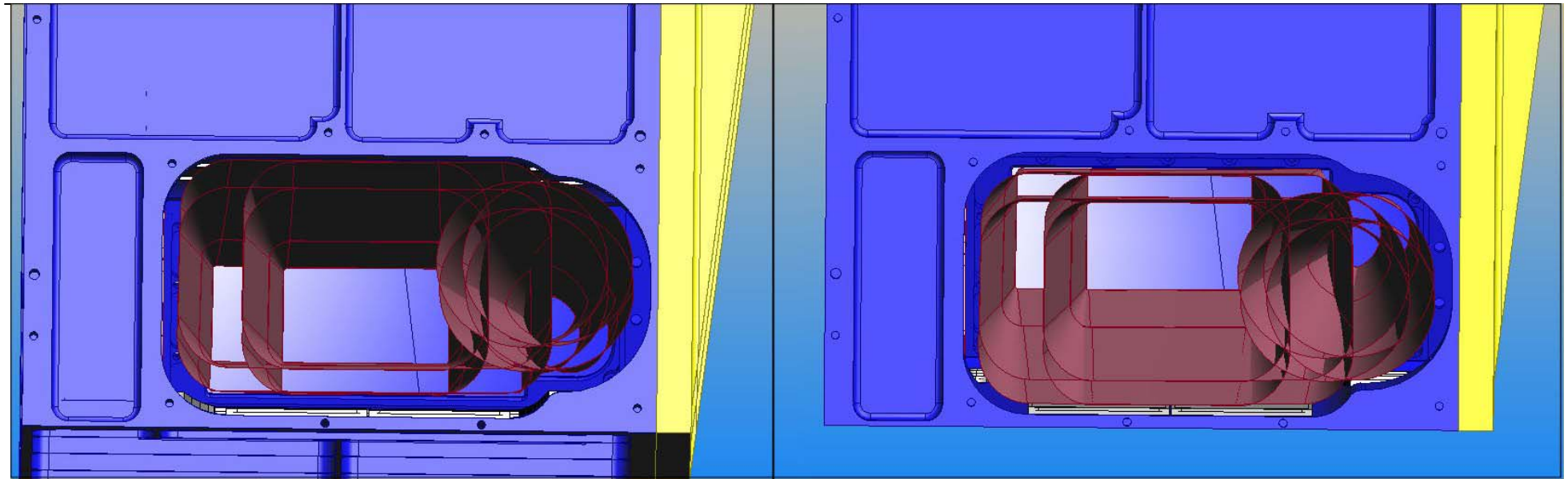

Figure 22 - Two views into SPIRE Input baffle showing clearance between the oversized beams and the tiles.

8.7.1. Input baffle ("Snout") +Z Face Tiles (SPZ)

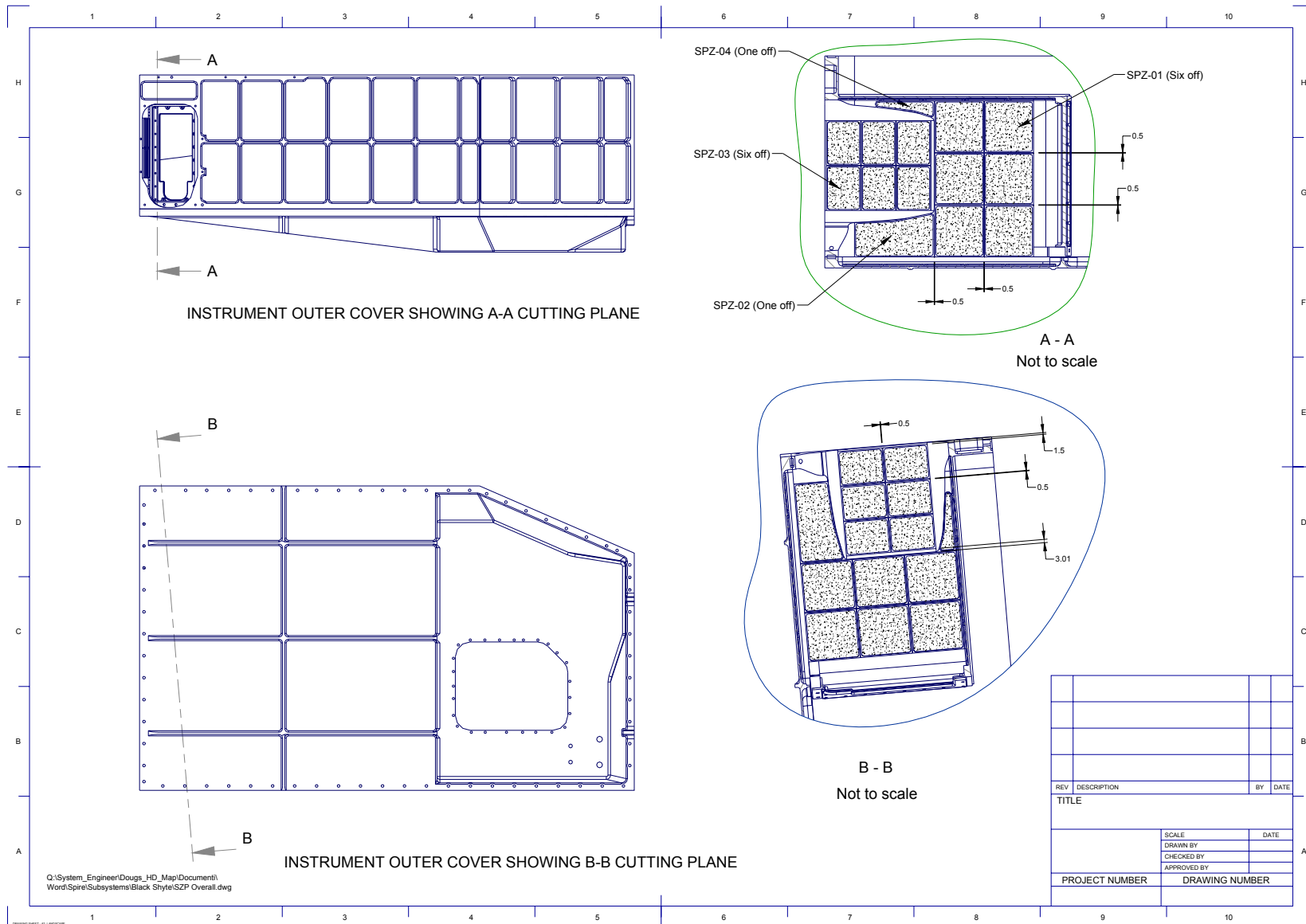

Figure 23 - Identification and positioning of SPZ Tiles

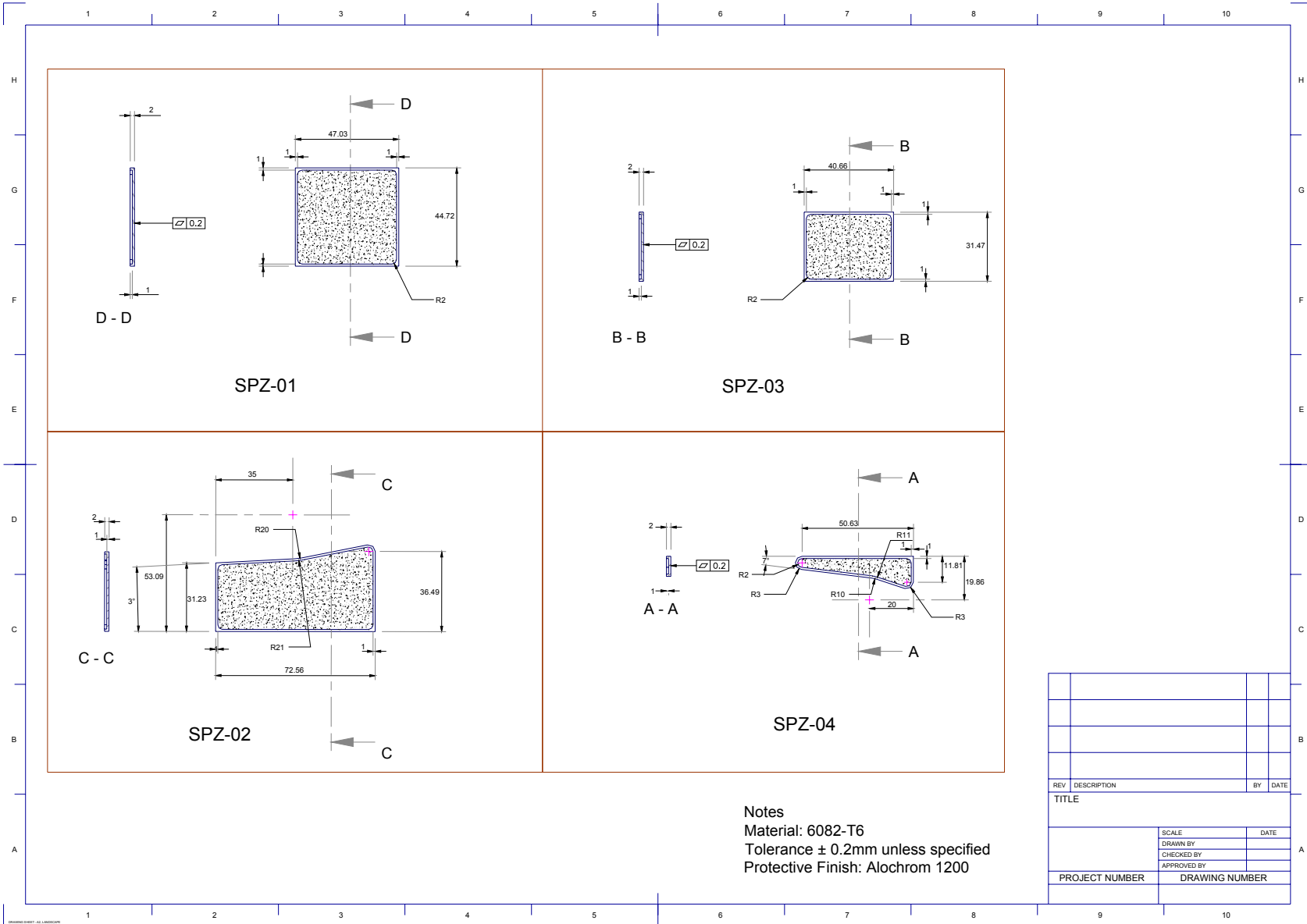

Figure 24 – Details of SPZ Face Tiles.

8.7.2. Input baffle ("Snout") –Z Face Tiles (SMZ)

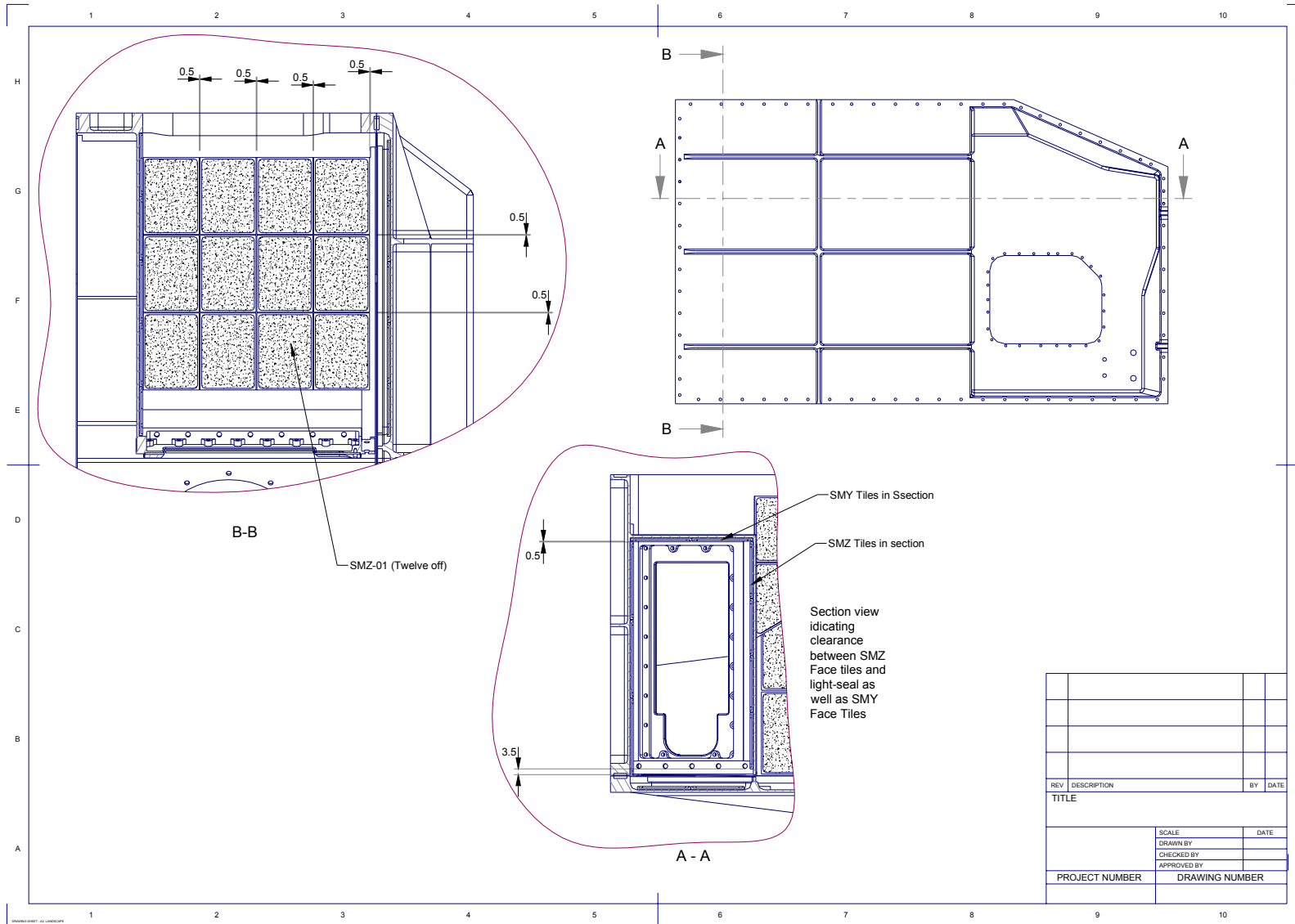

Figure 25 -- Identification and positioning of SMZ Tiles

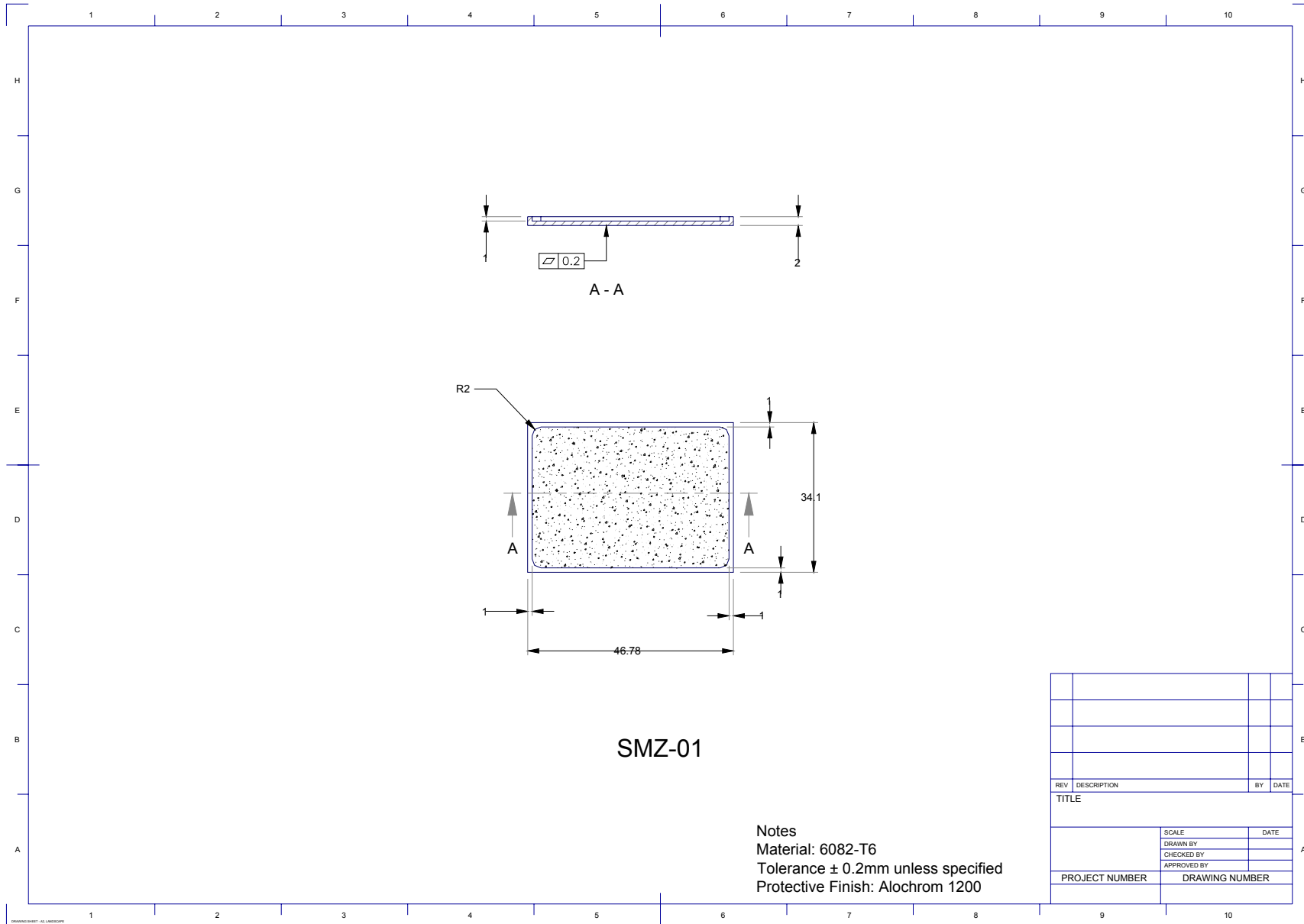

Figure 26 - Details of SMZ Face Tiles.

8.7.3. Input Baffle ("Snout") +Y Face Tiles (SPY)

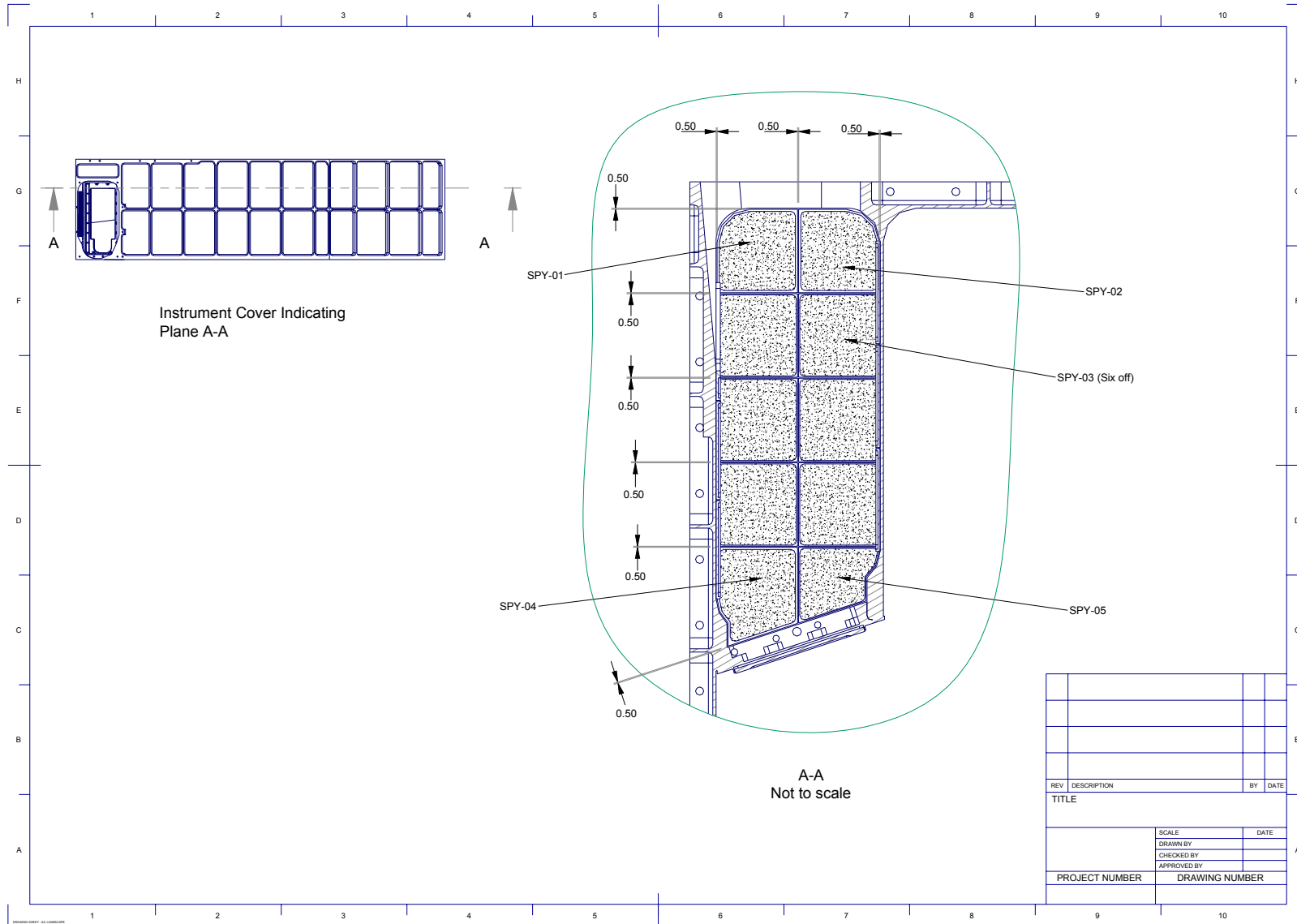

Figure 27 - Identification and positioning of SPY Face Tiles

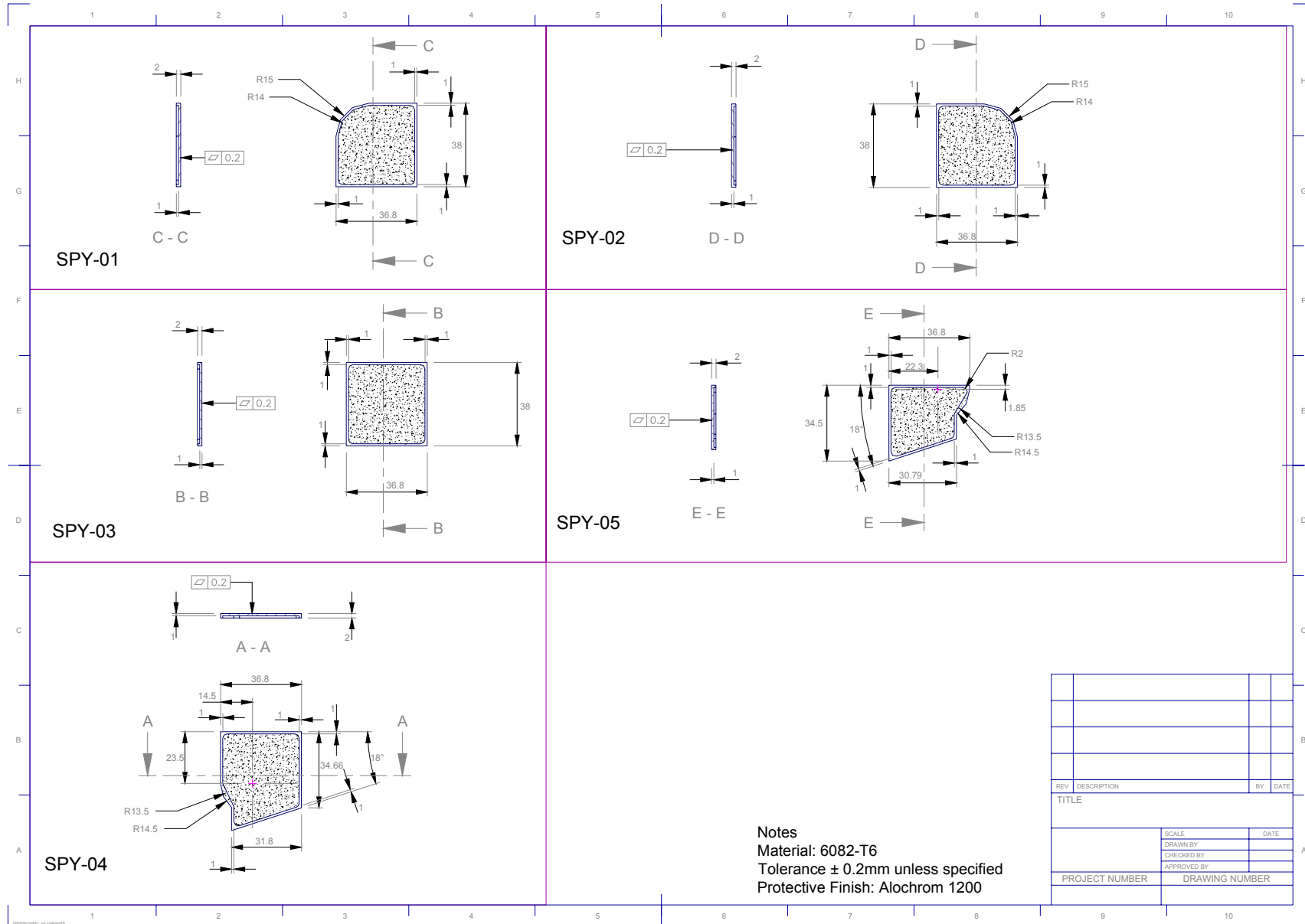

Figure 28 - Details of SPY Face Tiles.

8.7.4. Input Baffle ("Snout") –Y Face Tiles (SMY)

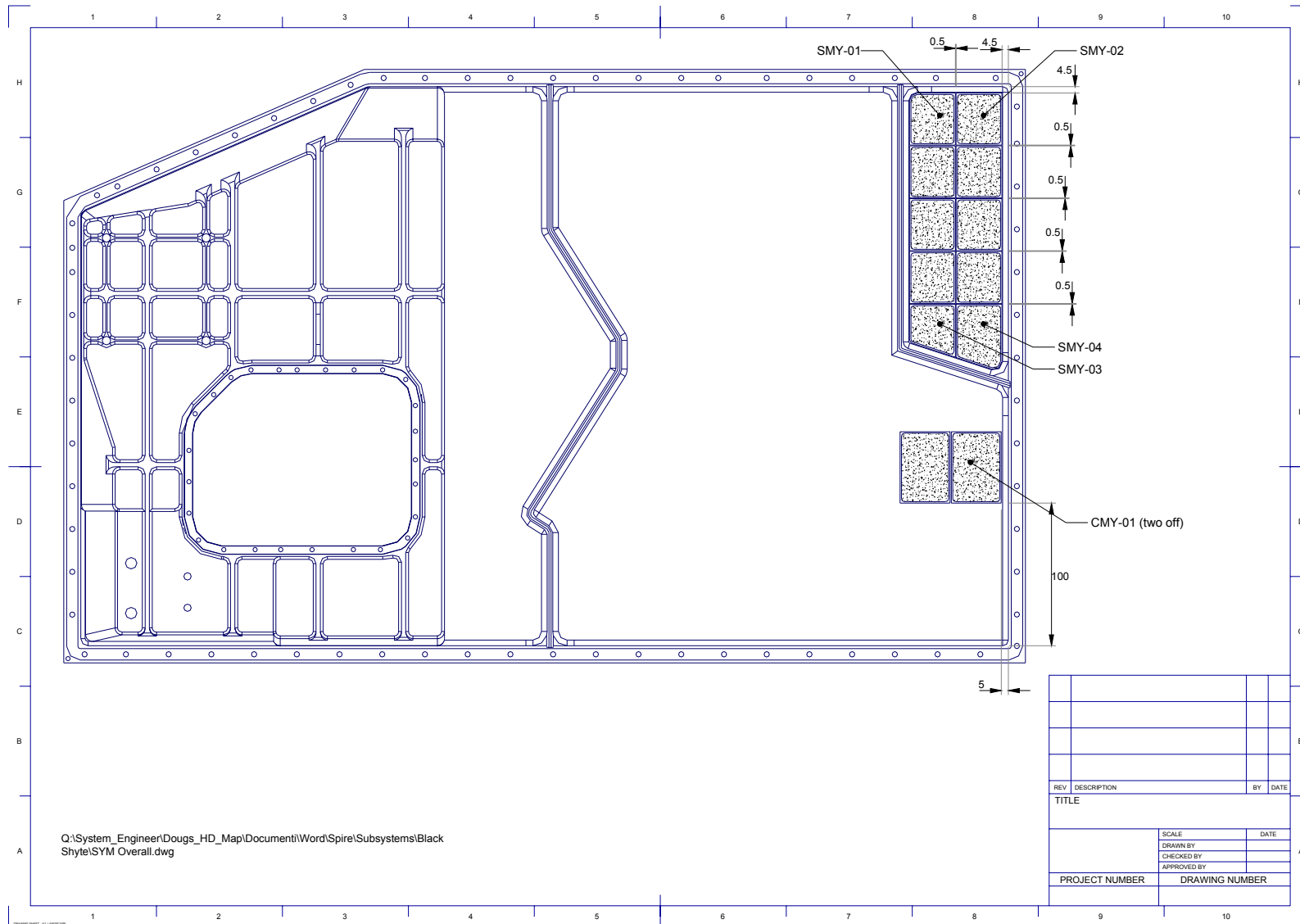

Figure 29 - Identification and positioning of SMY Face Tiles as well as the CMY Tiles

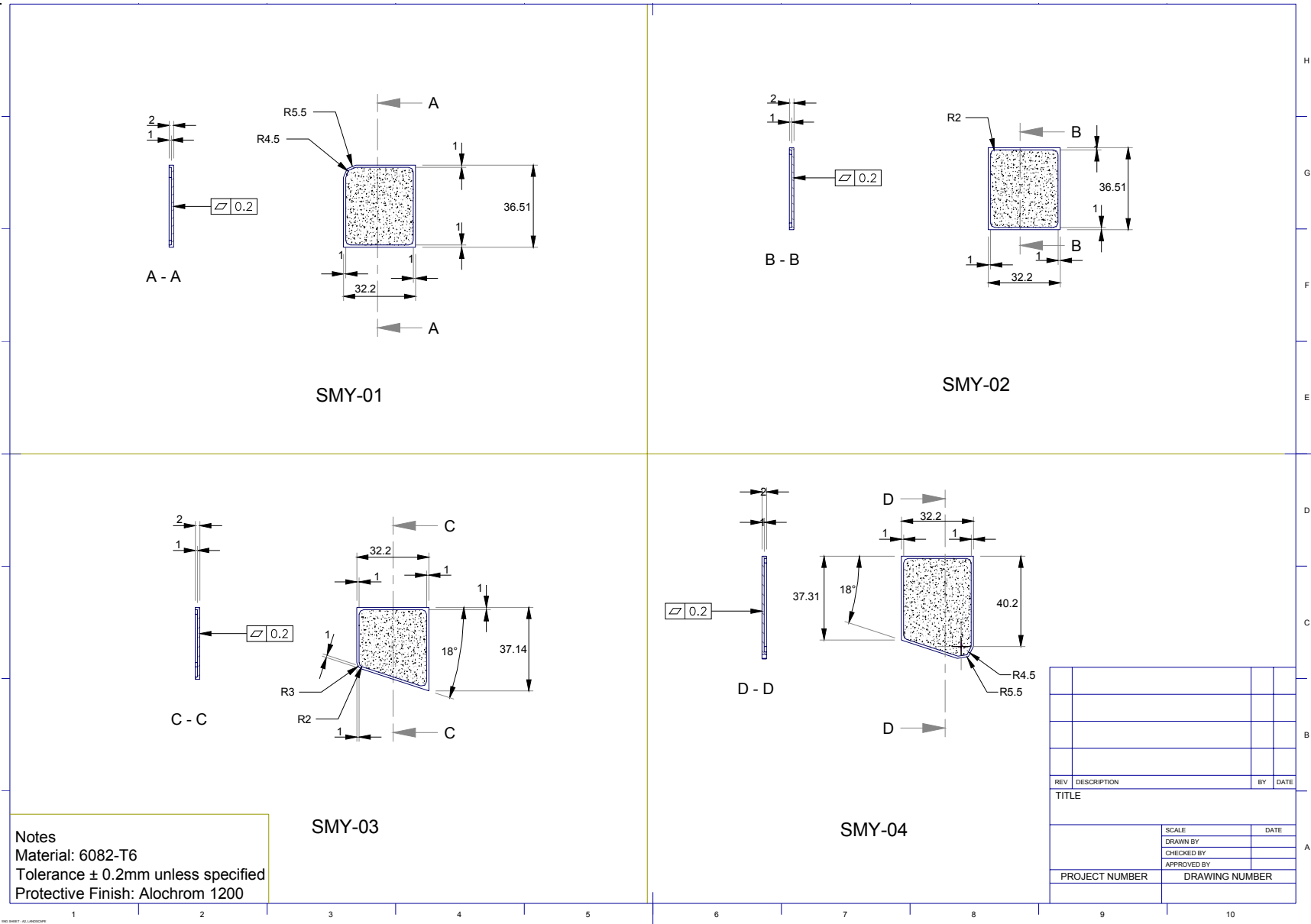

Figure 30 - Details of SMY Face Tiles.

8.8. Cover Tiles

8.8.1. Cover -X Face Tiles (CMX)

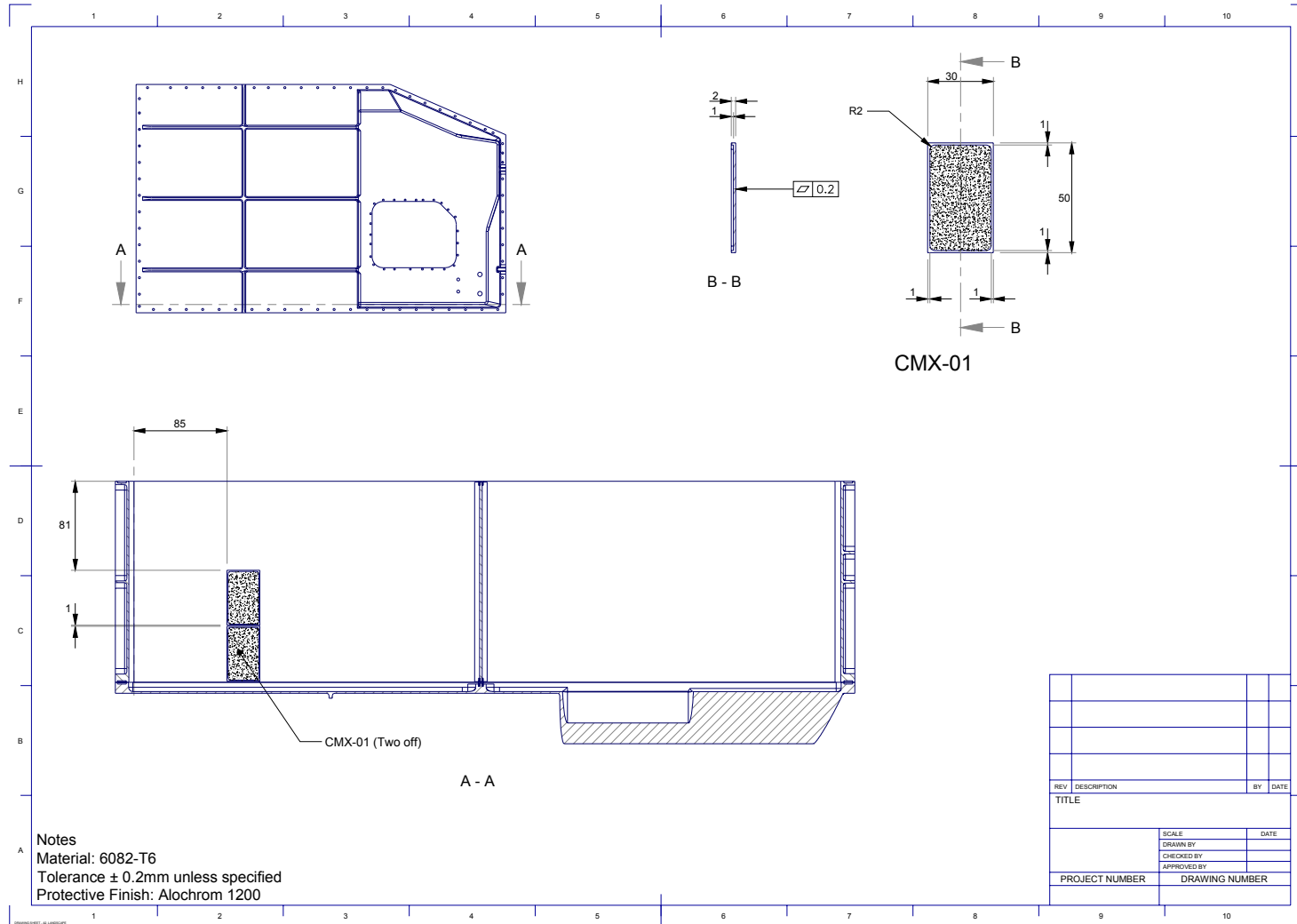

Figure 31 Identification and positioning of CMX Face Tiles

8.8.2. Cover +Z Face Tiles (CPZ)

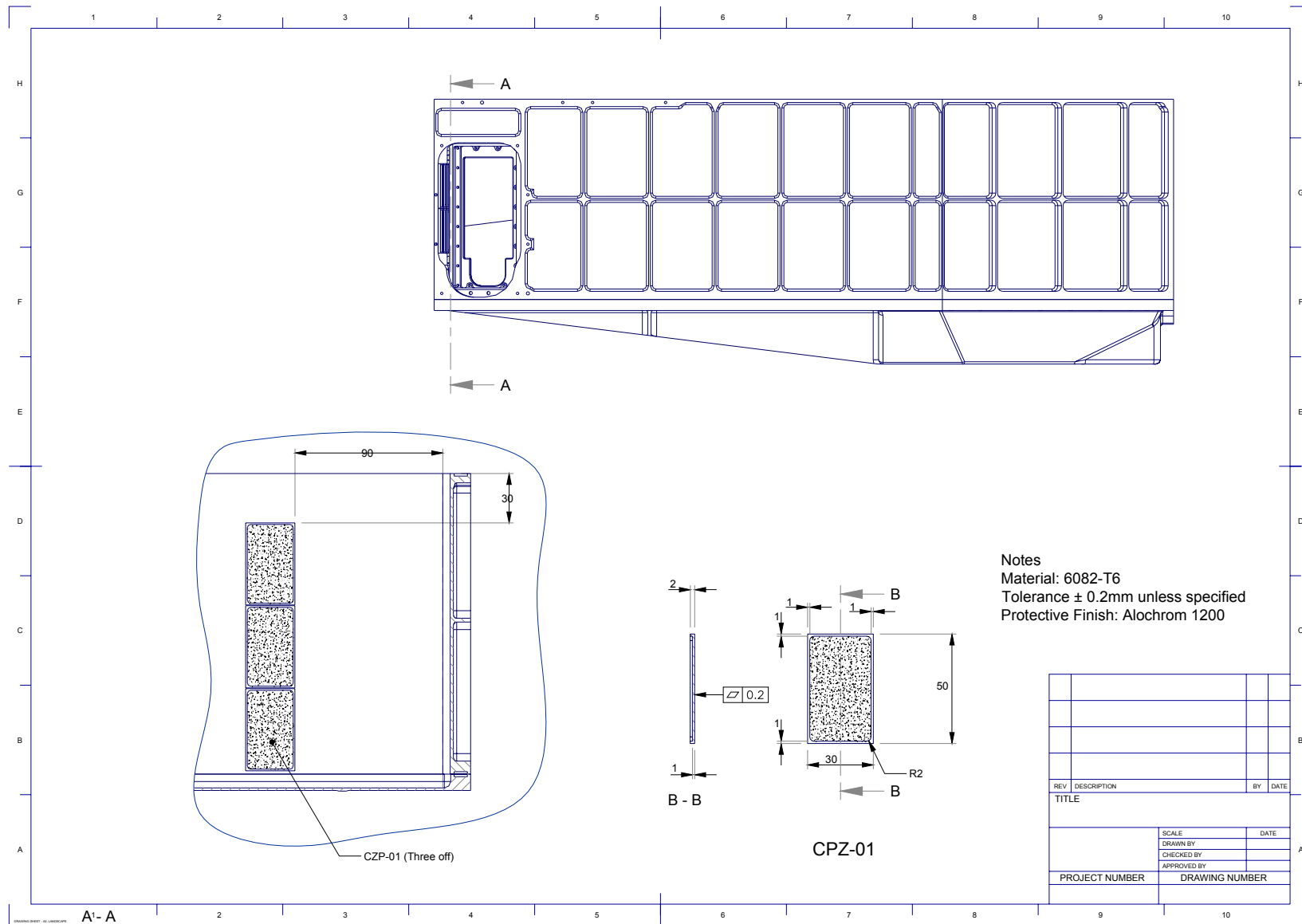

Figure 32 Identification and positioning of CPZ Face Tiles as well as the details of the CPZ Tiles.

8.8.3. Cover –Y Face Tiles (CMY)

For tile location see §8.7.4 - Input Baffle (“Snout”) –Y Face Tiles (SMY)

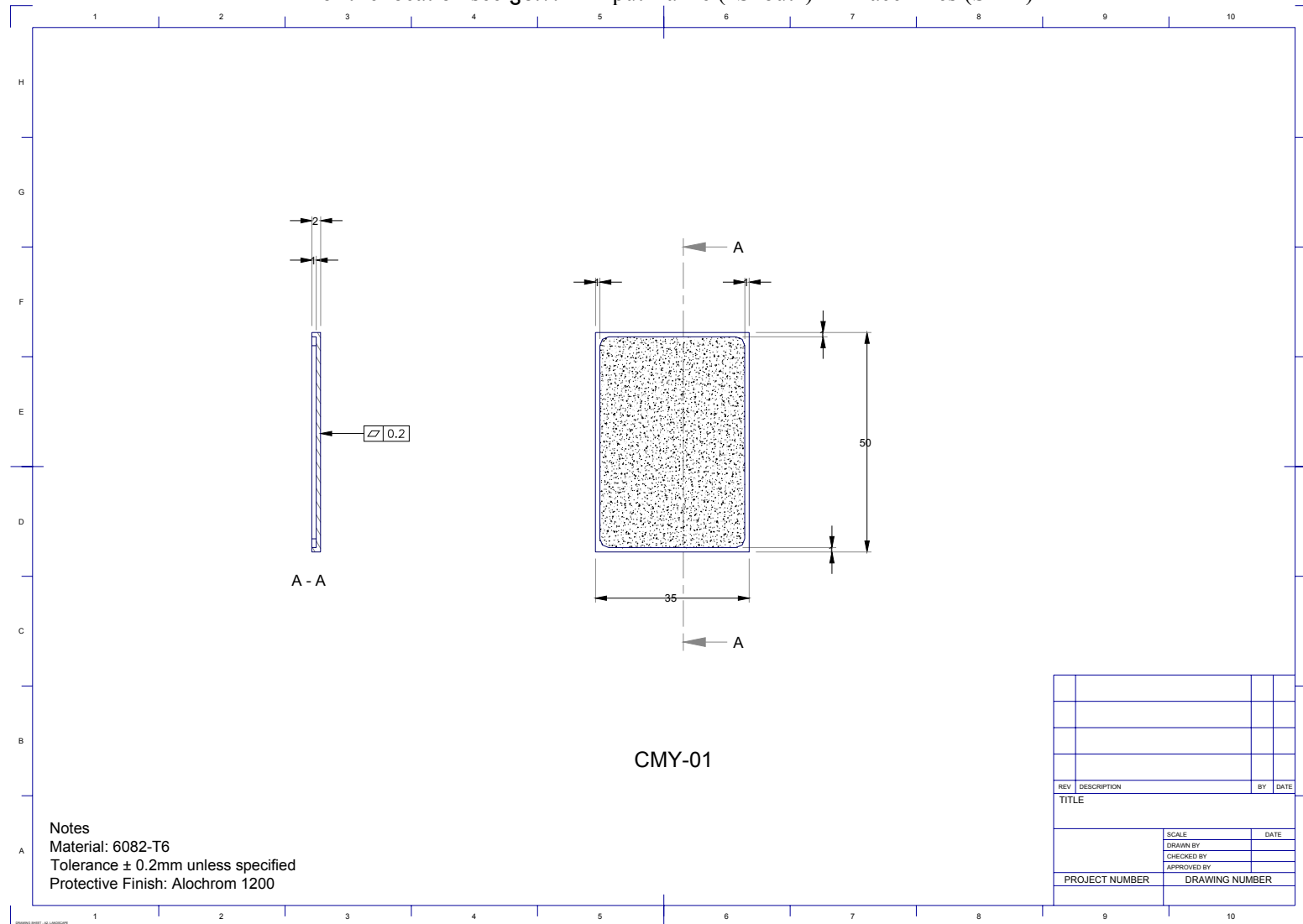

Figure 33 – Details of the CMY face tiles.

8.9. Optical Sub-bench Tiles (OSB)

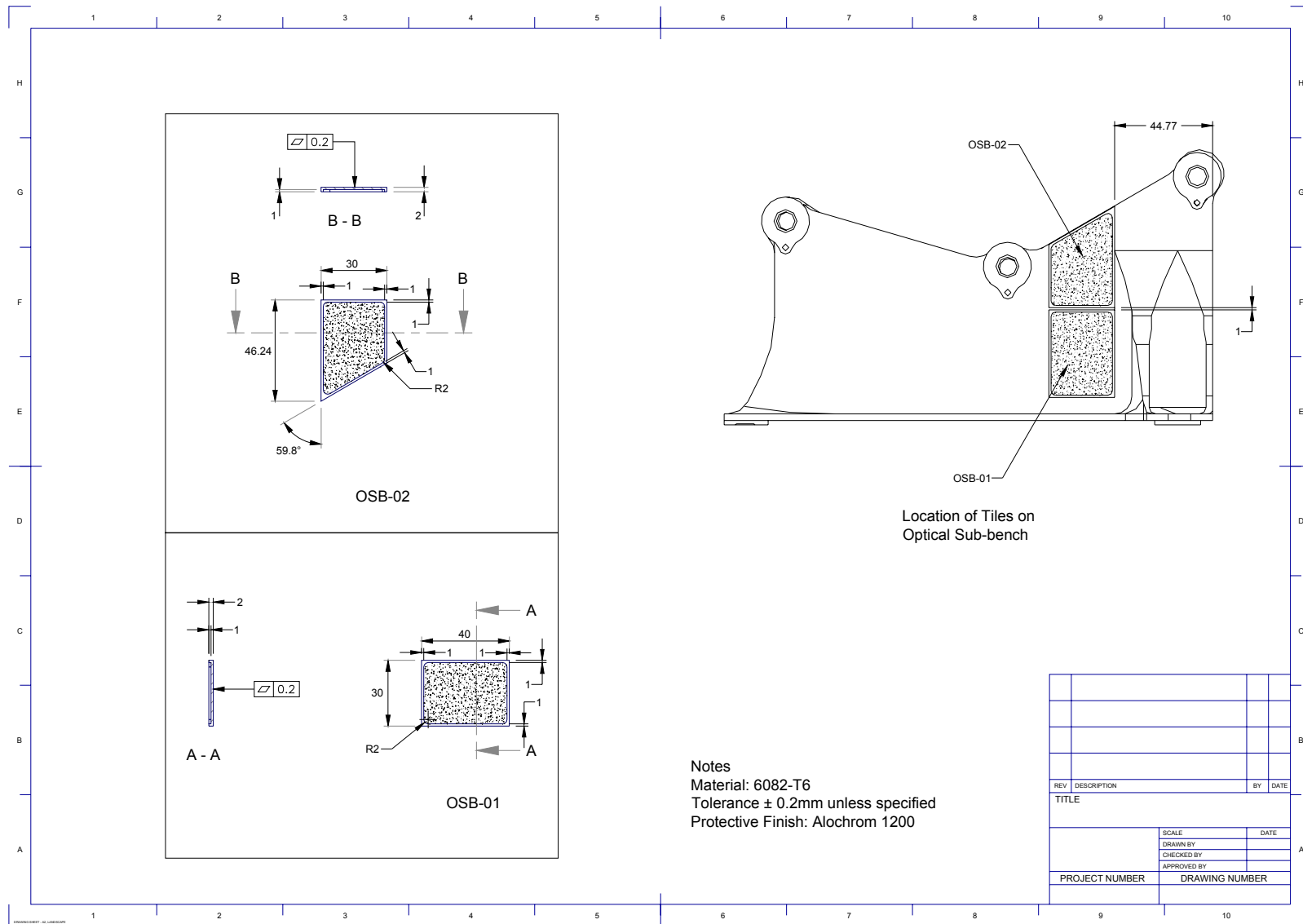

Figure 34 - Optical Sub-bench tiles.

8.10. Level-0 Strap Stray-Light Baffles

Painted black is to be applied to each of the three Instrument Level-0 strap Stray-Light Baffles. The location of the Black is specified in AD3.

9. Appendix One – Tile Application Procedure

Assumptions

- A. Both the instrument and the tile are assumed to have been cleaned and baked out
- B. The surfaces of both the instrument and tile have been passivated with Alocrom 1200.
- C. The tiles are to be applied in batches. Each batch is to consist of adjacent tiles on a single flat surface. A new batch of tiles can be applied once the adhesive has cured.
- D. The process is to be carried out in a clean room environment (Class 10 000 or better) with controlled temperature and humidity.

Procedure

1. Any subsystems installed on the instrument that are sensitive to contamination and are close to the area to be tiled are to be removed.
2. Rotate the instrument so that the surface to which the tiles are to be applied is horizontal
3. Clean the entire surface of the instrument where the tiles will be applied with an IPA wipe
4. Clean the back face of the tiles with an IPA wipe
5. Apply a short length of Kapton or Aluminium tape with adhesive backing to the black area of the tile to construct a temporary handle. This is to ensure that the tile can be easily handled and positioned on the instrument when there is adhesive on the tile. See Figure 35. Repeat for each tile in the batch.

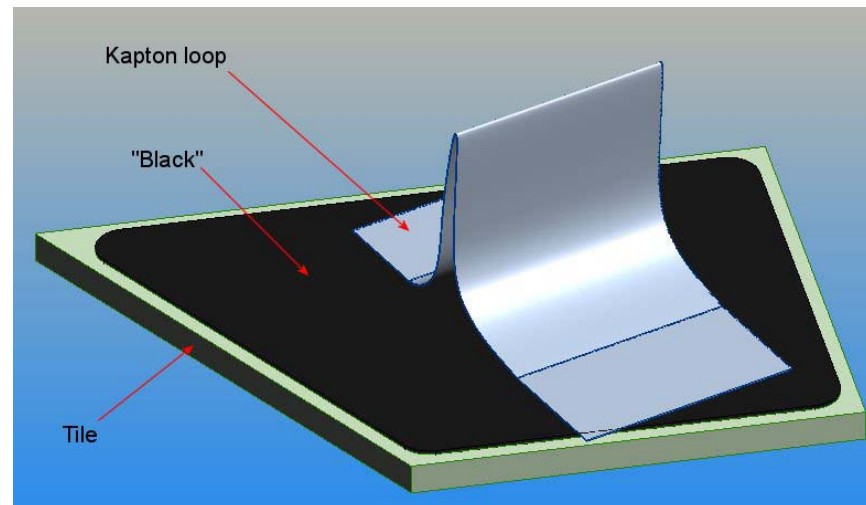

Figure 35 – Tile with “Kapton handle”

6. Where necessary, apply lengths of Kapton tape to the instrument to (a) mask surrounding areas of the instrument and (b) provide reference locations for the positioning of the tiles. This would be necessary, for example when the tiles are located in the middle of a panel and there are no features against which the tiles can be easily referenced.
7. Position all the tiles in the batch in their correct locations, taking care to ensure that they are in their correct orientations. Check that the tiles fit correctly.
8. Mix a batch of Scotchweld EC 2216 according to the manufacturers data sheet. (ESA PSS-01-701 Sheet No; S-7)
9. Apply a film of Scotchweld to the entire surface of the instrument to be covered with tiles. (estimate 100-200um thickness) This is to be done with a chemically inert spatula. If there are screws used to secure the tile in place, then the area within 5mm of the screw hole is to be left uncoated.
10. Cut two lengths of Stainless Steel wire Ø0.1, 316L Goodfellow Part# 459-006-15. The lengths of the wire are to be approximately $\frac{3}{4}$ of the length of the sides of the tile.
11. Apply a film of Scotchweld to the back face of the tile. (estimate 100-200um thickness) This is to be done with a chemically inert spatula. If there are screws used to secure the tile in place, then the area within 5mm of the screw hole is to be left uncoated.
12. Lay the two lengths of wire on the film of adhesive so that when the tile is applied to the instrument, it will rest on the wire. This wire is to provide an electrical contact between the tile and the instrument.
13. Apply the tile to the instrument. Any screws used to secure the tile to the instrument are to be inserted along with any associated nuts and washers. The screw is to be fully tightened. Firm pressure is to be applied to the surface of the tile to ensure that the adhesive is squeezed out of the joint and that 100% contact is made between the tile and the instrument.
14. Repeat steps 9 through 12 for all the tiles.
15. Before the adhesive cures, check and correct the positioning of the tiles. Where necessary, the tiles can be temporarily held in position with Kapton tape. Short lengths of clean Ø1mm and Ø0.5mm wire can be used to assist in achieving a uniform spacing of the tiles, however they are to be removed before the adhesive starts to harden.
16. Retain the remaining adhesive in the same environment to monitor the cure of the adhesive.
17. Once the adhesive has cured, each tile is to be inspected for adhesion and electrical contact with the chassis of the instrument. An NCR is to be raised if incomplete adhesion is suspected. Any tile that is found to be electrically isolated from the chassis of the instrument (See §7, General Tile Requirements Number 3), is to be noted in the logbook. Two small beads of Epo-tek H20E - Electrically conductive Silver Epoxy are to be used to bond the isolated tile to either another tile or the chassis of the instrument.

End of Procedure.

10. Appendix Two – Qualification Tiles

The (1) tile application procedure and the (2) Black application procedure were qualified (with respect to adhesion under cold vibration) within the CQM instrument at CSL in April 2004. Two types of tiles were used to carry this out: Tile Type-1 and Tile Type-2 identified below. These two tiles correspond to

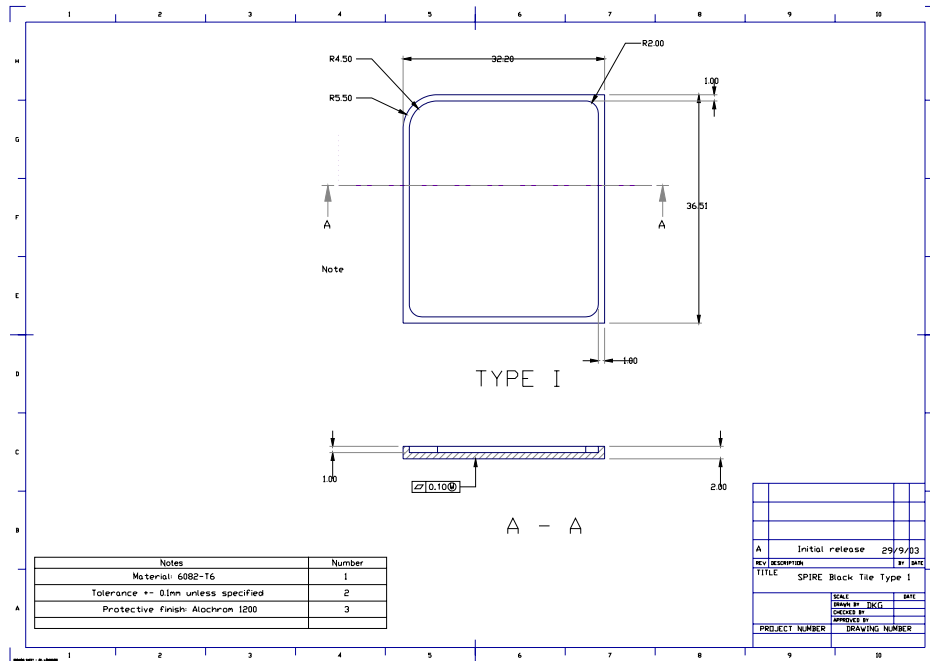

Figure 36 - Tile Type 1. Glued on outside cover

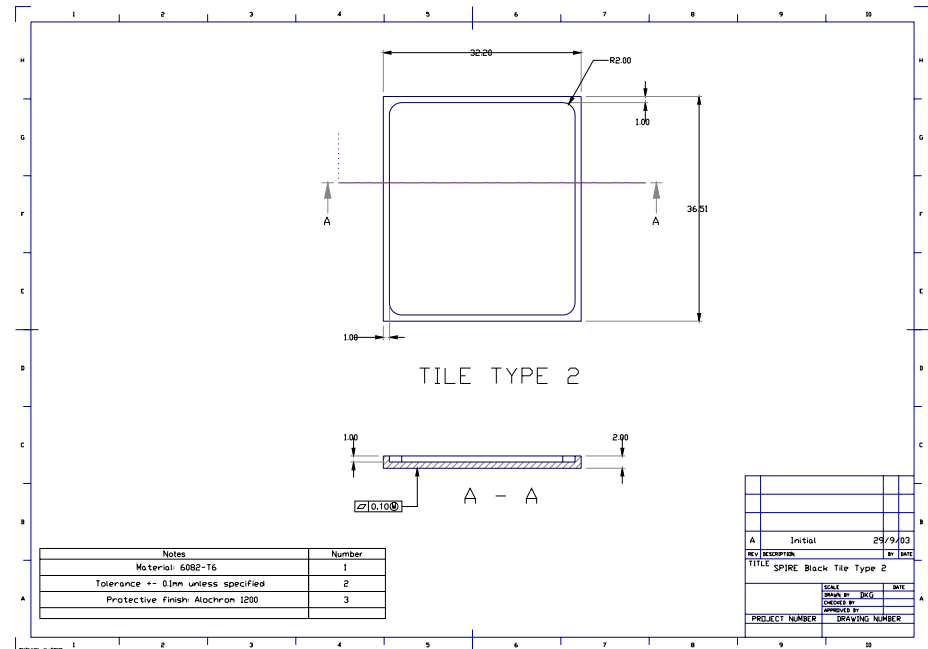

Figure 37 - Tile type 2. Glued on outside cover