

MULLARD SPACE SCIENCE LABORATORY

UNIVERSITY COLLEGE LONDON Author: C BROCKLEY-BLATT

---

**SPIRE – STRUCTURE ASSEMBLY, INTREGRATION AND HANDLING**

Document Number: MSSSL/SPIRE/SP006.02 March 2003 DRAFT

Distribution:

<b>Spire Project Office</b>	<b>B Winter</b>	<input type="checkbox"/>
<b>ESA PX</b>	<b>A Heske</b>	<input type="checkbox"/>
	<b>J Bruston</b>	<input type="checkbox"/>
	<b>J Rautakoski</b>	<input type="checkbox"/>
<b>RAL</b>	<b>B Swinyard</b>	<input type="checkbox"/>
	<b>E Sawyer</b>	<input type="checkbox"/>
	<b>J Delderfield</b>	<input type="checkbox"/>
	<b>J Long (Project Office)</b>	<input type="checkbox"/>
<b>Mullard Space Science Laboratory</b>	<b>A Smith</b>	<input type="checkbox"/>
	<b>J Coker</b>	<input type="checkbox"/>
	<b>C Brockley-Blatt</b>	<input type="checkbox"/>
	<b>A Dibbens</b>	<input type="checkbox"/>
<b>ATC</b>	<b>C Cunningham</b>	<input type="checkbox"/>
	<b>I Pain</b>	<input type="checkbox"/>
	<b>T Paul</b>	<input type="checkbox"/>
<b>Cardiff</b>	<b>P Hargrave</b>	<input type="checkbox"/>
	<b>CSA</b>	<input type="checkbox"/>
	<b>COMDEV</b>	<input type="checkbox"/>
	<b>JPL</b>	<input type="checkbox"/>
	<b>J Bock</b>	<input type="checkbox"/>
<b>UofS</b>	<b>J Lilienthal</b>	<input type="checkbox"/>
	<b>J Taylor</b>	<input type="checkbox"/>
<b>CEA</b>	<b>L Duband</b>	<input type="checkbox"/>
<b>Herschel Project</b>	<b>Herschel.Planck@esa.int</b>	<input type="checkbox"/>

**Author:** C Brockley-Blatt **Date:**

**Checked:** B Winter **Date:**

**Approved:** Tony Dibbens **Date:**

	<b>SPIRE</b>	<b>Project Document</b>	<b>Ref:</b> MSSL/SPIRE/SP006.01
		<b>Integration and Handling</b>	<b>Issue:</b> 2.0 DRAFT
			<b>Date:</b> March 2003
			<b>Page:</b> Page 2 of 23

## Change Record

ISSUE	Date	Brief description of change
1.0	December 2002	New document
2.0	March 03	Updated with the results from the MSSL fit check

	<b>SPIRE</b>	<b>Project Document</b>	<b>Ref:</b> MSSL/SPIRE/SP006.01
		<b>Integration and Handling</b>	<b>Issue:</b> 2.0 DRAFT
			<b>Date:</b> March 2003
			<b>Page:</b> Page 3 of 23

## Table of Contents

1.	Scope of Document .....	4
1.1	Description of Parts .....	4
2.	Documents .....	6
3.	Drawing List.....	6
4.	Packing and Unpacking .....	6
5.	Handling .....	6
6.	Cleaning.....	7
7.	Storage.....	7
8.	Installation onto MGSE.....	7
8.1	Part and Fixings Preparation .....	7
8.2	Base Plate Assembly .....	7
8.3	Optical Bench Attachments.....	9
8.4	Locking .....	10
8.5	Spire Optical Bench Fitting.....	10
8.6	Optical Bench Alignment .....	13
9.	Lubrication Application.....	14
10.	Assembly of subsystems .....	14
10.1	Optical Bench .....	15
10.2	Photometer 2K Detector Box.....	16
10.3	Spectrometer 2k Detector Box.....	17
10.4	Spectrometer 300mK Thermal Strap System.....	17
10.5	Photometer 300mK Thermal Strap System.....	18
10.6	Photometer Cover.....	18
10.7	Spectrometer Cover .....	21
10.8	Mounts onto the Optical bench.....	21
10.9	Mirror on Mount.....	22
10.10	General Assembly .....	22
11.	Integration.....	22
11.1	Integration Procedure .....	22
	APPENDIX 1 .....	23

## Table of Figures

Figure 1	Structure Hardware Tree
Figure 2	Structure Drawing List

	<h1>SPIRE</h1>	Project Document	Ref:	MSSL/SPIRE/SP006.01
		Integration and Handling	Issue:	2.0 DRAFT
			Date:	March 2003
			Page:	Page 4 of 23

## Glossary

All terms are listed in the CIDL.

## 1. SCOPE OF DOCUMENT

This document presents integration and handling procedures for the Spire Structure (breakdown of the product into sub-assemblies), and a list of associated drawings. These procedures relate only to the STM. A separate document will be issued for the EQM and FM. This document will have accompanying diagrams in later issues.

### 1.1 Description of Parts

The SPIRE structure consists of a monocoque shell with a central optical bench. The structure is mounted on a fixed point (cone-shaped), suppressing translation in all directions. This fixed point is located on the corner of the optical bench. On the other side of the instrument (+Z direction) two blade mounts (A-frames) are mounted suppressing each translation in the plane of the frame itself. All in all this results in a semi-kinematic suspension with as a fixed reference with regard to the HERSCHEL optical bench, the cone.

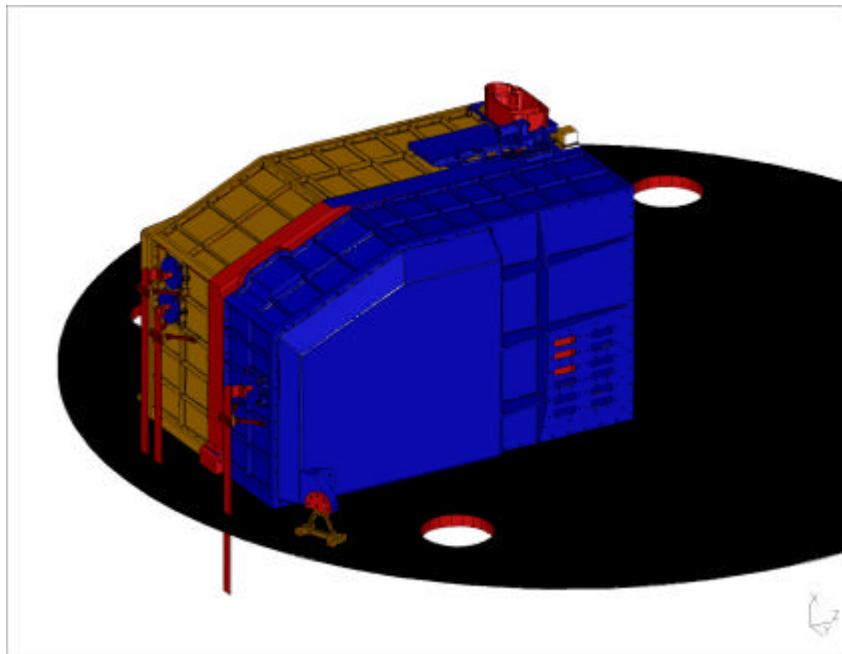



Figure 1.1-1: View of the outside of the instrument – Common Structure + Mounting

As said before the SPIRE instrument consists of a monocoque shell that provides a bending stiff, internal, SPIRE optical bench. This optical bench supports a photometer and a spectrometer. All parts of these two sub-instruments are mounted on the SPIRE optical bench. See figure 1.1-2 for the photometer side of the optical bench, including IR-beams.

	<b>SPIRE</b>	<b>Project Document</b>	<b>Ref:</b> MSSL/SPIRE/SP006.01
		<b>Integration and Handling</b>	<b>Issue:</b> 2.0 DRAFT
			<b>Date:</b> March 2003
			<b>Page:</b> Page 5 of 23

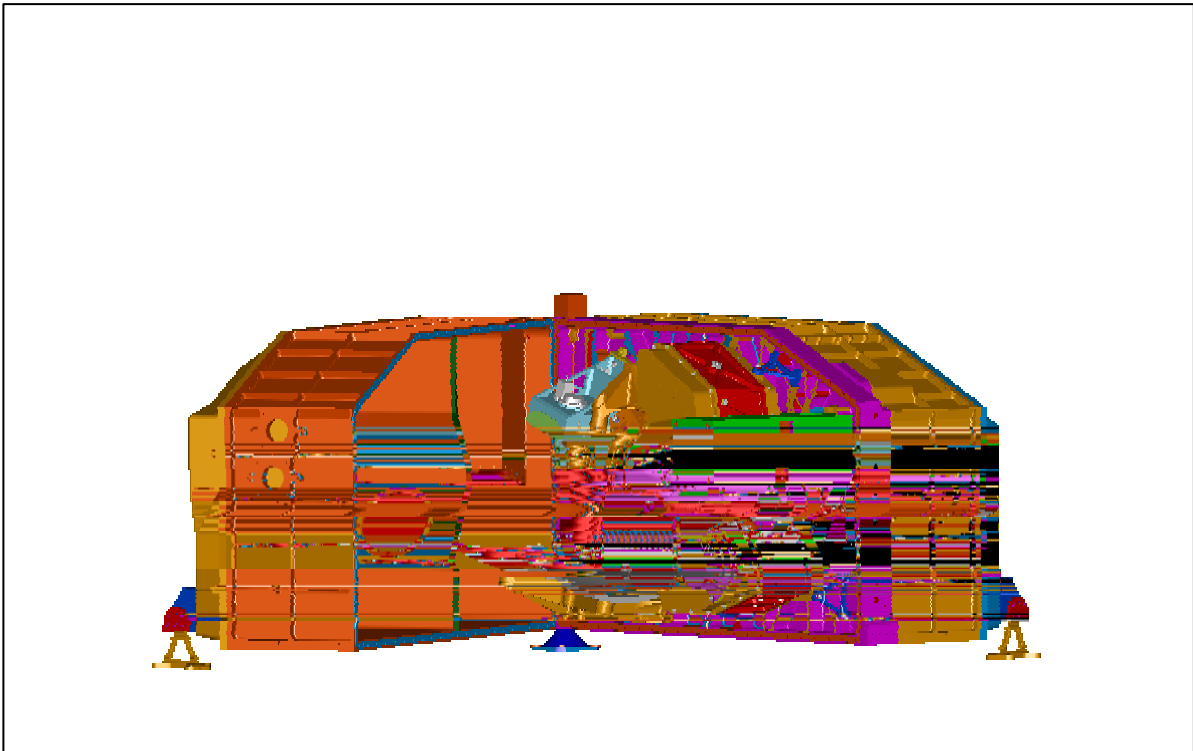

Figure 1.1-2: View of the inside of the instrument – photometer side, cover taken off

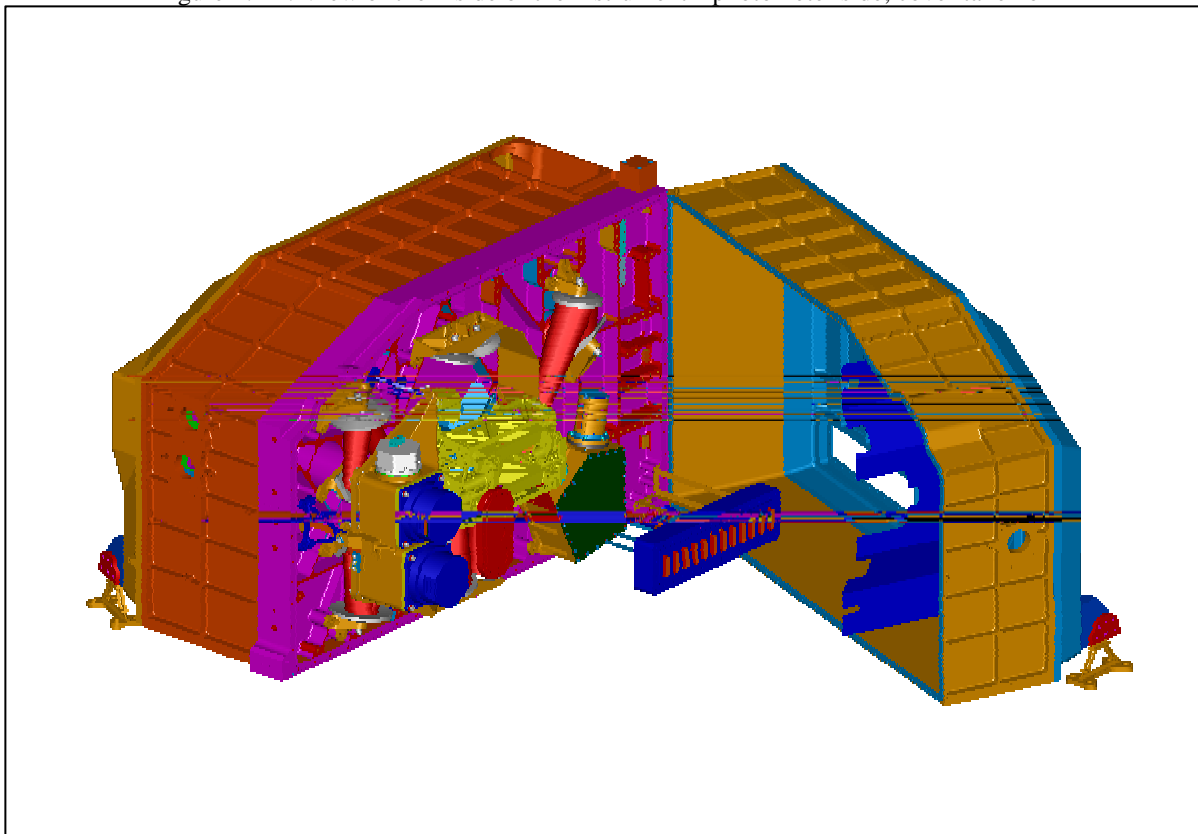



Figure 1.1-3: View of the inside of the instrument – spectrometer side, cover taken off

	<b>SPIRE</b>	<b>Project Document</b>	<b>Ref:</b> MSSL/SPIRE/SP006.01
		<b>Integration and Handling</b>	<b>Issue:</b> 2.0 DRAFT
			<b>Date:</b> March 2003
			<b>Page:</b> Page 6 of 23

The instrument is divided into different temperature zones. The reason for this is the relative high interface temperature of the HERSCHEL optical bench and the low operating temperature of the detectors inside the instrument. The interface temperature is 6-10 Kelvin where as the operating temperature of the detectors is ~0.3 Kelvin. The temperature zones in between are the temperature of the monocoque structure with the optical bench at ~4 Kelvin and the boxes holding the detectors, filters and dichroics at ~2 Kelvin.

## 2. DOCUMENTS

All documents are listed in Figure 3.2 of the CIDL.

## 3. DRAWING LIST

The Structure Hardware Tree and associated Drawings for integration are presented in the figures in Appendix 1.

## 4. PACKING AND UNPACKING

All parts of the Spire Structure STM are double bagged in clean-room standard bagging material (i.e. bagging material should not outgas contaminants to contents) and positioned in their individual custom transport containers.

## 5. HANDLING

The SPIRE STRUCTURE STM is clean and must be handled using approved clean room gloves. It should be kept in a clean room of class 100,000 or better . If this is not available, the units should be bagged with clean room bagging material. Failure to keep the unit either in a clean room or bagged particulate tight will allow the re-introduction of contaminants and require re-cleaning.

The SPIRE STRUCTURE STM contains no active electronics and therefore does not require any special ESD precautions.

From the mechanical point of view, the STMs should be handled exactly as demanded by flight hardware, including the following precautions:

- Aperture Cover should remain on the SPIRE STRUCTURE STM at all times when it is not in use.
- Before installation or fit check of any part, all surfaces on the SPIRE STRUCTURE STM assembly and the part itself should be visually checked for damage. It is recommended that any small crevices should be blown out with dry nitrogen before mating. Before engagement, check the condition of screw threads and helicoils and after engagement, tighten the screw to the specified torque given on the assembly interface drawing or in this document.

	<b>SPIRE</b>	<b>Project Document</b>	<b>Ref:</b> MSSL/SPIRE/SP006.01
		<b>Integration and Handling</b>	<b>Issue:</b> 2.0 DRAFT
			<b>Date:</b> March 2003
			<b>Page:</b> Page 7 of 23

## 6. CLEANING

After testing and prior to delivery, the SPIRE STRUCTURE STM will be ultrasonically cleaned. The protective covers will be removed for this operation and cleaned separately using either Isopropyl or ethyl alcohol (reagent grade or better).

After cleaning, the SPIRE STRUCTURE STM will be vacuum baked at 80 °C at  $<10^{-5}$  mbar for a minimum of 48 hours. The cleaned covers will then be refitted. The SPIRE STRUCTURE STM will then be double bagged in clean-room bags, with the inner bag purged with dry nitrogen.

In the event that further cleaning becomes necessary, use only a vacuum cleaner.

Particulate matter may be removed using ionised filtered air or dry nitrogen.

For further detail, refer to the Spire Structure Cleanliness Document, AD54.

## 7. STORAGE

When not in use, it is recommended that the SPIRE STRUCTURE STM be double bagged in clean-room bags, and fitted into its transport container. All parts and the assembly should be covered when not in use even when in a clean room.

## 8. INSTALLATION ONTO MGSE

Use these instructions in conjunction with drawing A1-5264-404 shts 1 and 2 SPIRE OPTICAL BENCH ASSEMBLY FIXTURE (GENERAL ARRANGEMENT) See this drawing for orientation of Right and LEFT hand

### 8.1 Part and Fixings Preparation

All parts are to be cleaned with IPA and bagged for entry into a cleanroom environment

### 8.2 Base Plate Assembly

1. Lay base plate on a suitable flat surface (block up if preferred)

	<b>SPIRE</b>	<b>Project Document</b>	<b>Ref:</b> MSSL/SPIRE/SP006.01
		<b>Integration and Handling</b>	<b>Issue:</b> 2.0 DRAFT
			<b>Date:</b> March 2003
			<b>Page:</b> Page 8 of 23

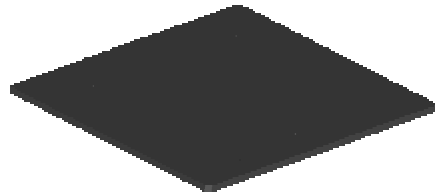

- Fit end plates and loosely secure fixings. The end plates are marked A and B (Right is A and the Left is B)

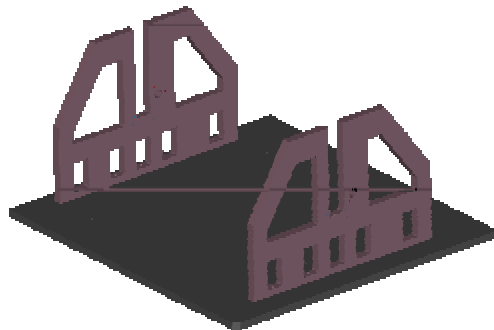

- Fit a Gusset Plate at each end of the End Plate (Left and right Gusset Plate, marked 1 to 4)



	<h1>SPIRE</h1>	Project Document	Ref: MSSL/SPIRE/SP006.01
		Integration and Handling	Issue: 2.0 DRAFT
			Date: March 2003
			Page: Page 9 of 23

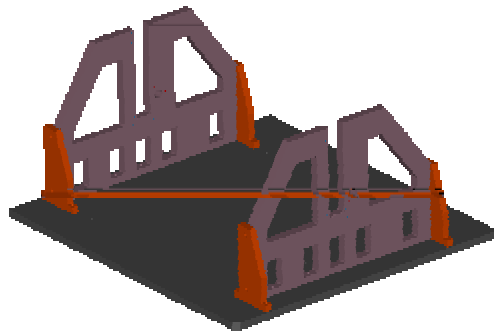

4. Tighten all screws to securely fix these items into position. The Dowels should be lubricated.

### 8.3 Optical Bench Attachments

1. Fit a bearing into a Lower Bearing Housing.
2. Attach the Lower Bearing Housing to the left hand End Plate

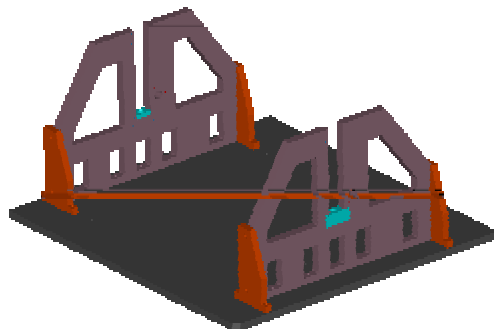

3. Fit a bearing into an Upper Bearing Housing
4. Wind a Jacking Nut onto one of the Lead Screws until centered on the shaft with the "V" upper most (towards the long plain shaft end). Lubricate.
5. Engage the shorter plain end of the Lead Screw into the Lower Bearing at the left hand End Plate with the Jacking Nut "V" facing toward the other End Plate and engaged into the End Plate slot. Lubricate.
6. Fit one Upper Bearing and Housing onto the top end of the Lead Screw.
7. Locate the Upper Bearing Housing into the End Plate slot and secure into position at top of the End Plate.
8. Fit a Bearing Cap over the Lead Screw onto the Upper Bearing

	<b>SPIRE</b>	<b>Project Document</b>	<b>Ref:</b> MSSL/SPIRE/SP006.01
		<b>Integration and Handling</b>	<b>Issue:</b> 2.0 DRAFT
			<b>Date:</b> March 2003
			<b>Page:</b> Page 10 of 23

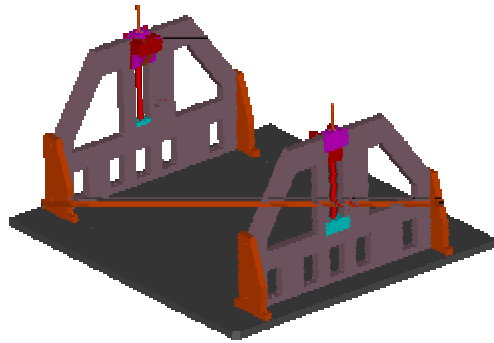

9. Fit a Winding handle to the top of this Lead Screw and secure then wind the Nut up just short of the Bearing Housing lower surface.
10. Repeat this section for the right hand end.

## 8.4 Locking

1. Fit the Locking Shaft Assembly to the left hand End Plate and allow Shaft and Locking Ring to run freely.

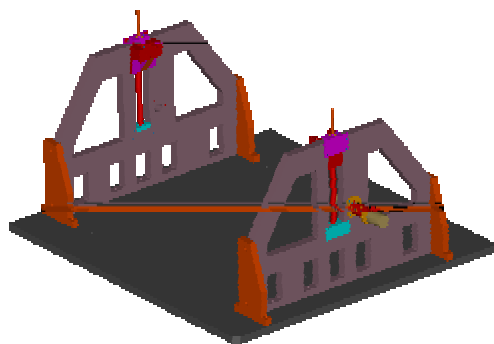

2. Pull the Shaft out against the pin stop and leave loose

## 8.5 Spire Optical Bench Fitting

1. Fit the Combined Pivot to the front surface of the Spire Optical Bench (Cone mounting end)

	<h1>SPIRE</h1>	Project Document	
		Integration and Handling	
		Ref:	MSSL/SPIRE/SP006.01
		Issue:	2.0 DRAFT
		Date:	March 2003
		Page:	Page 11 of 23

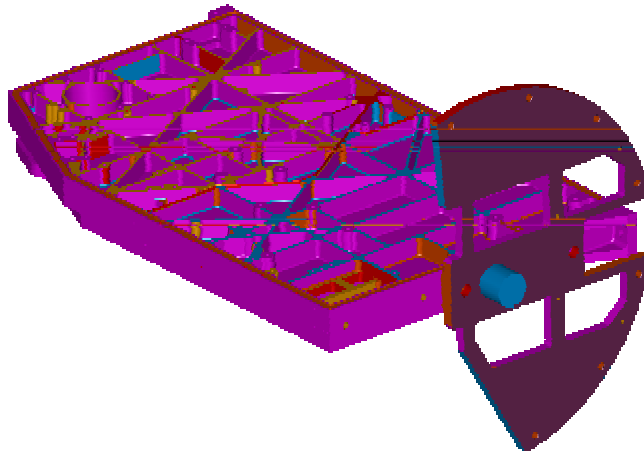

The Photometer Cover has been removed for clarity in this figure

2. Fit the Rear Pivot to the other end face.

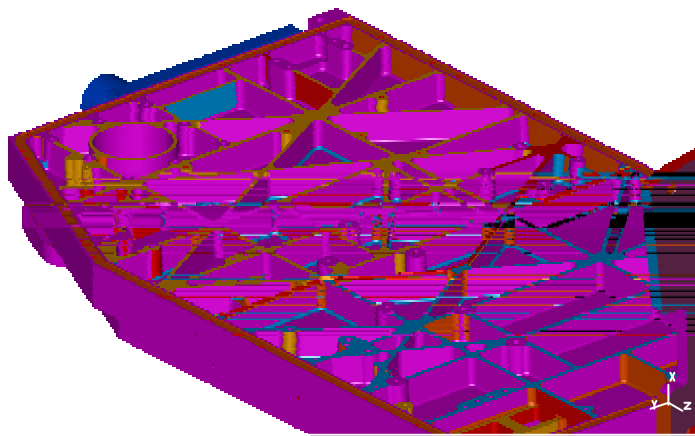

The Photometer Cover has been removed for clarity in this figure

3. Fit the Front and Rear Blade Mounts to the Pivots.

	<h1>SPIRE</h1>	Project Document	Ref:	MSSL/SPIRE/SP006.01
		Integration and Handling	Issue:	2.0 DRAFT
			Date:	March 2003
			Page:	Page 12 of 23

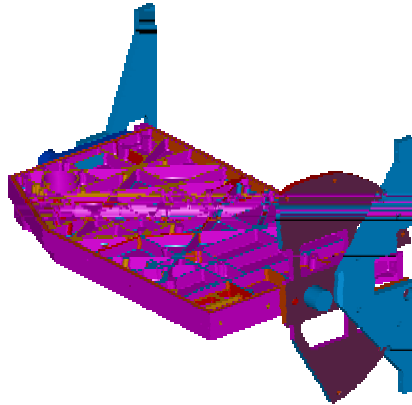

The Photometer Cover has been removed for clarity in this figure

- Screw 2 Fine Jacking Screws into each Blade Mount.

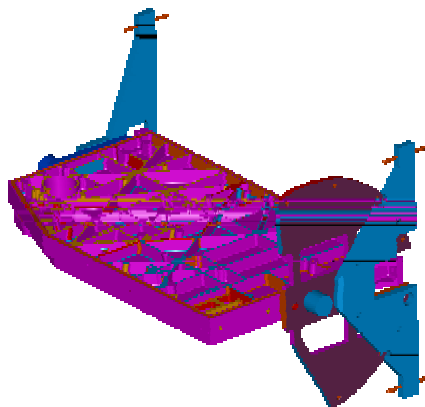

The Photometer Cover has been removed for clarity in this figure

- The Optical Bench is now ready to mount into the fixture.
- Insert preformed stainless steel shims into each Jacking Nut "V" (smear inside surface with a minimum amount of Apiazon AP100)
- Lift the Optical Bench complete with end Pivots and lower until each Pivot boss is located the preformed shims.
- Verify that the Optical Bench rotates forward and backward to an angle of +/-90 degrees from the vertical position.

	<b>SPIRE</b>	<b>Project Document</b>	<b>Ref:</b> MSSL/SPIRE/SP006.01
		<b>Integration and Handling</b>	<b>Issue:</b> 2.0 DRAFT
			<b>Date:</b> March 2003
			<b>Page:</b> Page 13 of 23

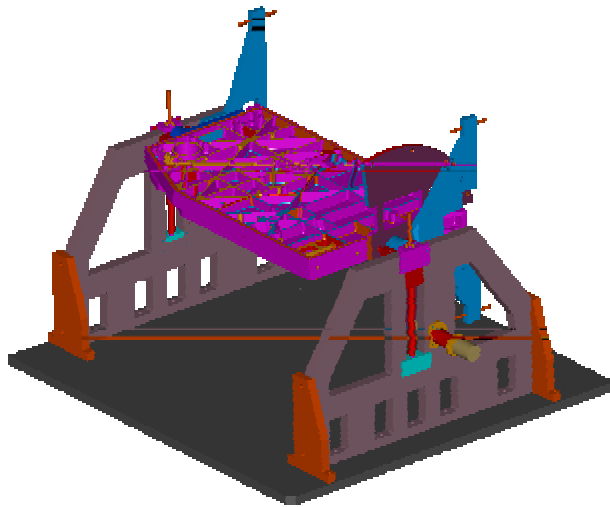

The Photometer Cover has been removed for clarity in this figure

9. Fit a Pivot Clamp over each Pivot Boss tighten down to allow bench to rotate back and forth loosely.

## 8.6 Optical Bench Alignment

1. Rotate the Optical Bench to a vertical position with the Photometer side facing the operator.
2. Ensure that the base plate is level
3. Wind both Jacking Nuts up to mate with the underside of each Upper Bearing Housing, check that the Optical Bench top surface is level  $\pm 3$  arc' (an inspection quality spirit level should be used for this operation) minor adjustments should be made to the heights of the Jacking Nuts.
4. Secure the Pivot Clamps to allow  $\pm 90$  degrees rotation from the vertical without any slop at the Pivot Boss/Jacking Nut interface.
5. Screw the Lock Shaft into the mating hole in the Combined Pivot (screw up so that the mating faces lock together without tending to deflect the Combined Pivot - the complete Optical Bench / Pivots assembly should be eased towards the Lock Shaft End Plate while carrying out this operation, if necessary. When complete there should be approximately 3mm clearance between the Combined Pivot Shaft end face and the end face of the Jacking Nut "V").
6. With the Lock Shaft firmly engaged with the Combined Pivot, lock the assembly in position using the Lock Ring but do not over tighten either the Lock Shaft or Lock Ring.
7. Verify that the Optical Bench Photometer surface is vertical and top surface is horizontal
8. Disengage the Lock Ring and Shaft then rotate the Optical bench 90 degrees forward or backward then re-engage the Lock Shaft with the Combined Pivot and secure. Always disengage the lockshaft before rotating the optical bench.
9. Using the spirit level verify that the Optical Bench upper most surface is level to 3arc' in 2 opposite directions from face to face and diagonal.
10. Do this operation for the opposite rotation.
11. Put the jack nut clamp plates in place.
12. Once all alignments have been verified and any amendments carried out, assembly of the Spire Optical Bench can continue to completion.

	<b>SPIRE</b>	<b>Project Document</b>	<b>Ref:</b> MSSL/SPIRE/SP006.01
		<b>Integration and Handling</b>	<b>Issue:</b> 2.0 DRAFT
			<b>Date:</b> March 2003
			<b>Page:</b> Page 14 of 23

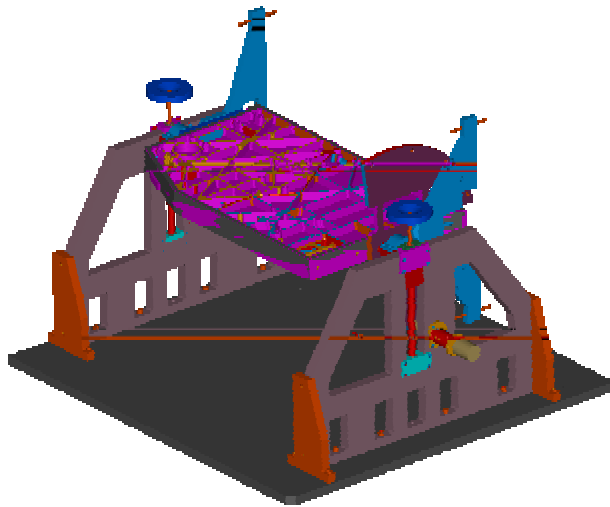

The Photometer Cover has been removed for clarity in this figure

## 9. LUBRICATION APPLICATION

The following is the application procedure:

- Clean the screw
- Apply with scriber tip a small dab of Apiezon Ap100 to the first thread of screw
- Wind screw into hole.

Ensure that the lubricant is not picked up on gloves and distributed to parts during assembly/disassembly procedures. If in doubt, change gloves after handling areas.

## 10. ASSEMBLY OF SUBSYSTEMS

The SPIRE instrument consists of a monocoque shell that provides bending stiffness to the stiff optical bench. This optical bench supports a photometer and a spectrometer. All parts of these two measurement devices are mounted on the optical bench. The instrument is mounted on the FIRST optical bench via three interfaces. Two A-frames and a conical fixed point. These interfaces ensure a controlled contraction of the instrument when it is cooled down. The optical bench panel is on one side mounted on the fixed point, the side closest to the optical axis of the telescope. The two A-frames are mounted on the two corners furthest away from the fixed point. The bending flexible direction of the A-frames is pointing towards the fixed point. Thus making the whole suspension semi-kinematic.

The integration of the Spire structure is a very delicate operation. During the whole process great care has to be taken not to compromise the (future) alignment of the optical components. The inaccuracy of machining of the various parts will lead to a build up of alignment errors of the structural interfaces upon which the various optical components will be mounted. The build up of this misalignment runs through the whole structure. It starts with the mounting of the instrument, continues through the covers and the optical bench. It is therefore of paramount importance that during integration the build-up of misalignment is minimised and moreover, to ensure that the

	<b>SPIRE</b>	<b>Project Document</b>	<b>Ref:</b> MSSL/SPIRE/SP006.01
		<b>Integration and Handling</b>	<b>Issue:</b> 2.0 DRAFT
	<b>Date:</b> March 2003		
	<b>Page:</b> Page 15 of 23		

construction and integration is done such that what ever the misalignment is, it will not change significantly after dismounting and re-mounting the covers.

The total allowable misalignment (error budget) of the optical components is given in AD24. The development plan, giving a listing of the various models required, is AD28. A more detailed description of the structure can be found in AD27.

## 10.1 Optical Bench

With reference to drawing A1/5264/305- Optical Bench Assembly and the following points.

1. Mount Optical Bench onto the surface table

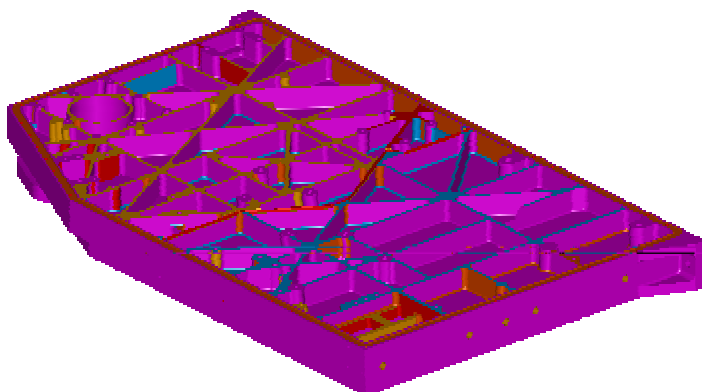

2. Fit Photometer covers to procedure 10.6
3. Install into MGSE, following procedure 8
4. Fit Spectrometer cover to procedure 10.7
5. Remove photometer cover
6. Fit secondary optical bench
7. Fit SM06 and PM06 mirror mounts
8. Fit PM8 mirror mount
9. Fit SM06 mirror (if available)
10. Fit Common Mirrors, CM03 and CM05 onto the secondary optical bench (if available)
11. Fit PM07 mirror onto the secondary optical bench (if available)
12. Fit the Beam Steering Mechanism
13. Replace the Photometer cover
14. Take off the spectrometer cover – Please note that there are 3 screws adjacent to the SCAL box where there is no access to unscrew them. Leave these out during alignment and integration but should be included during the final assembly.
15. Assemble SFIL2 mount on a separate bench

	<b>SPIRE</b>	<b>Project Document</b>	<b>Ref:</b> MSSL/SPIRE/SP006.01
		<b>Integration and Handling</b>	<b>Issue:</b> 2.0 DRAFT
			<b>Date:</b> March 2003
			<b>Page:</b> Page 16 of 23

16. Epoxy SOB dowels into the SFIL2 mount
17. Fit SFIL2 assembly
18. Fit SM7 mirror mount
19. Fit SM8A mirror mount
20. Assemble SBS 1 and SBS 2 on a separate bench
21. Fit SBS 1 assembly
22. Assemble SCAL Box on a separate bench
23. Fit the SMEC (if available)
24. Fit SCAL box
25. Fit SM9A/10A mirror mounts
26. Fit SM9B/10B mirror mounts
27. Fit SBS 2 assembly
28. Fit SM11A mirror mount
29. Fit SM11B mirror mount
30. Fit SM12A Mirror mount
31. Fit SM12B Mirror mount
32. Fit all of the spectrometer mirrors to the standard procedure
33. Fit all of the spectrometer baffles
34. Fit the Spectrometer Detector box assembly
35. Fit the RF filter box
36. Replace the spectrometer cover
37. Remove the photometer cover
38. Fit PM08 mirror (if available)
39. Fit PM06 mirror (if available)
40. Fit detector box straps to cooler
41. Fit cooler to optical bench
42. Fit the photometer box
43. Connect 2K interconnecting strap to photometer box
44. Fit the jointing strap that runs between the two detector boxes
45. Replace photometer cover - Please note that there are 3 screws adjacent to the Secondary Optical Bench where there is no access to unscrew them. Leave these out during alignment and integration but should be included during the final assembly.
46. Remove spectrometer cover
47. Connect up the Spectrometer detector box to its straps.

## 10.2 Photometer 2K Detector Box

With reference to Drawing A1/5274/306 – Photometer Box Assembly and the following points,



	<b>SPIRE</b>	<b>Project Document</b>	<b>Ref:</b> MSSL/SPIRE/SP006.01
		<b>Integration and Handling</b>	<b>Issue:</b> 2.0 DRAFT
			<b>Date:</b> March 2003
			<b>Page:</b> Page 17 of 23

1. Slide the two bus bar supports (Cardiff) onto the bus bar upper (Reference Cardiff MAIV plan AD40)
2. Secure the supports to the detector box outer cover
3. Fit the lower bus bar to the joint with the upper bus bar. Note that the end of the bus bar is vulnerable
4. Assemble the PDIC1 and PDIC2 mounts into the photometer box spine
5. Fit the mirror mounts using the standard procedure
6. Fit the mirrors using the standard procedure
7. Fit PFIL 3
8. Fit the dichronics and their rings
9. Fit the spine to the outer cover
10. Fit the detectors and make the joints between them and the bus bar
11. Fit the light trap to the spine, feeding it along the bus bar
12. Fit the harness supports to the outer cover
13. Fit the inner cover to the spine
14. Fit the BDA connector assembly to the harness supports
15. Fit the blade mounts to the inner cover. These should be left loose until the final fitting of the box to the optical bench. (Note that the blade mounts should not be fitted during transport of the detector, except when the box is fitted to the bench).
16. Fit photometer box cone to the optical bench

To disassemble the Photometer detector box,

1. Unscrew photometer detector box spine from the inner cover
2. Remove the spine, thus leaving the inner cover and legs on the optical bench

### 10.3 Spectrometer 2k Detector Box

With reference to Drawing A1/5274/307 – Spectrometer Box Assembly and the following points,

1. Integrate BDAs into bottom box
2. Assembly the 300mK Thermal Strap System separately to Procedure 10.4
3. Feed through the busbar assembly in to the spectrometer box
4. Check Flexible wire link with BDA
5. Mount straylight trap over the end of the busbar and screw it to the box.
6. Connect up thermal Busbar, by locking all screws and tying the busbar to the pads available on the detector.
7. Fit the filters, SFIL3, on the filter holder on a separate bench
8. Fit the filter holder onto the box
9. Fit the blade mounts

### 10.4 Spectrometer 300mK Thermal Strap System

	<b>SPIRE</b>	<b>Project Document</b>	<b>Ref:</b> MSSL/SPIRE/SP006.01
		<b>Integration and Handling</b>	<b>Issue:</b> 2.0 DRAFT
			<b>Date:</b> March 2003
			<b>Page:</b> Page 18 of 23

With reference to Drawing A3/5264/307B – Bus Bar assembly Spectrometer and the following points;

1. Silver solder the feed through and the light baffle junction
2. Silver solder the cold interface plate into the light trap straps (1 mm diameter rods)
3. Silver solder the rods on to the light baffle junction
4. Slide the loose bushes onto the feed through (3 mm diameter rod)

## 10.5 Photometer 300mK Thermal Strap System

With reference to Drawing A3/5264/306B – Bus Bar assembly Photometer and the following points;

1. Silver solder the two stop sleeves on to the upper bus bar
2. Silver solder the lower bus bar and the light trap feed through to the light trap bus junction
3. Silver solder each of the BDA to bus bar links (1 mm diameter rod) to the pads at both ends
4. Screw the clamp for the PSW link onto the lower bus bar
5. The other parts will be assembled during the photometer detector box assembly

## 10.6 Photometer Cover

With reference to Drawing A1/5274/302 – Photometer Cover Assembly and the following points;

1. Check cleanliness of surfaces
2. Fit Photometer cover wall to Optical bench

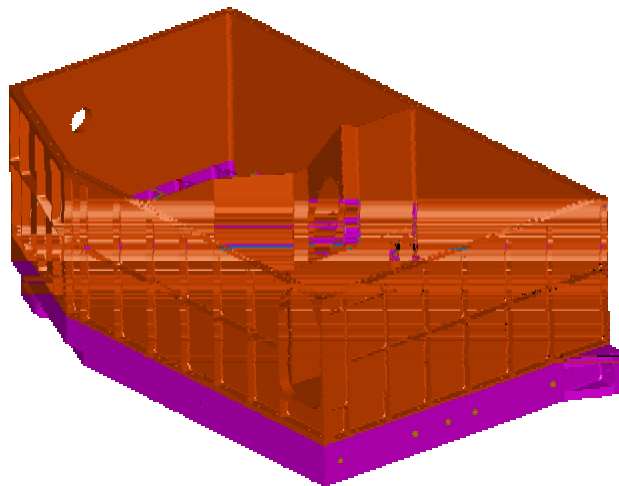

3. Check flatness before bolting down in sequence
4. Fit the bottom seal into the photometer cover wall

	<h1>SPIRE</h1>	Project Document	
		Integration and Handling	
		Ref:	MSSL/SPIRE/SP006.01
		Issue:	2.0 DRAFT
		Date:	March 2003
		Page:	Page 19 of 23

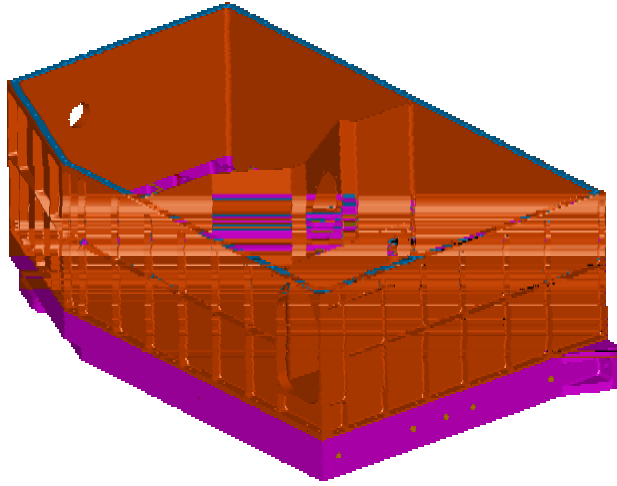

- Fit the lid to the photometer cover wall

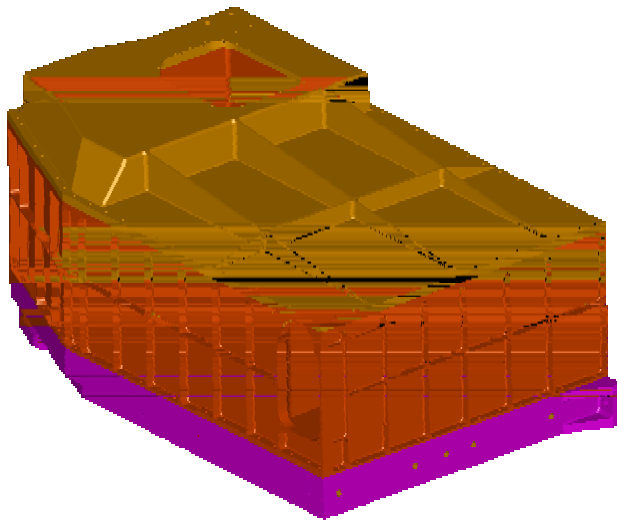

- Check trueness of the lid with the wall before bolting down in sequence
- Fit the blade mount bracket to the photometer cover lid

	<h1>SPIRE</h1>	Project Document	
		Integration and Handling	
		Ref:	MSSL/SPIRE/SP006.01
		Issue:	2.0 DRAFT
		Date:	March 2003
		Page:	Page 20 of 23

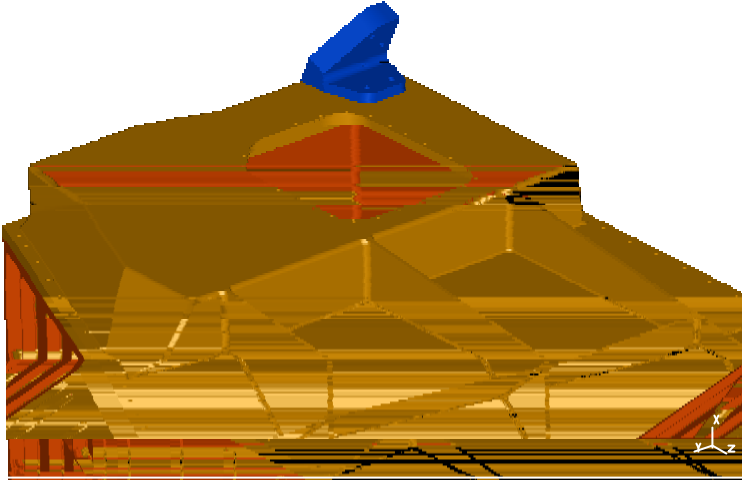

8. Fit the blade mount to the bracket. (Note that the blade mounts should not be fitted during transport of the cover, except where the FPU is fitted to the HOB and the MSSL MGSE is in place. Failure to do this will result in damage to the A-frames)

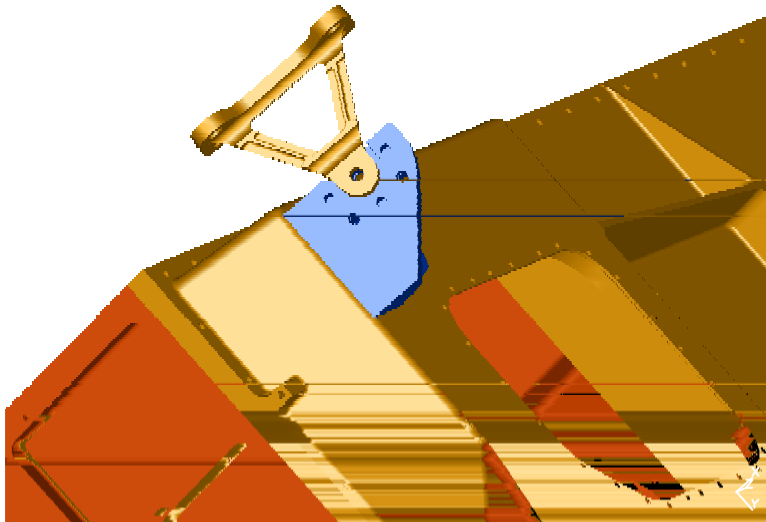

9. Fit the Dowel retention plate.

	<b>SPIRE</b>	<b>Project Document</b>	<b>Ref:</b> MSSL/SPIRE/SP006.01
		<b>Integration and Handling</b>	<b>Issue:</b> 2.0 DRAFT
			<b>Date:</b> March 2003
			<b>Page:</b> Page 21 of 23

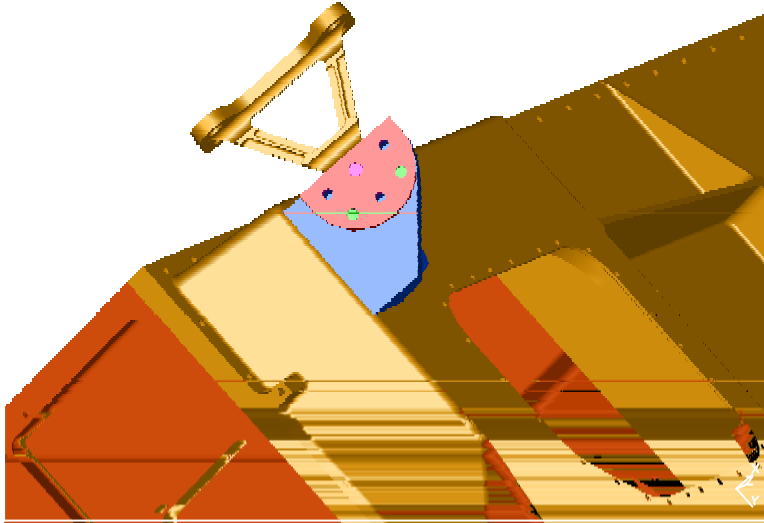

## 10.7 Spectrometer Cover

With reference to Drawing A1/5274/303 – Spectrometer Cover Assembly and the following points,

1. Check cleanliness of surfaces
2. Fit Spectrometer cover wall to Optical bench
3. Check flatness before bolting down in sequence
4. Fit the bottom seal into the spectrometer cover wall
5. Fit the main stray light baffle
6. Fit the lid to the spectrometer cover wall
7. Check trueness of the lid with the wall before bolting down in sequence
8. Fit the blade mount bracket to the spectrometer cover lid
9. Fit the blade mount to the bracket. (Note that the blade mounts should not be fitted during transport of the cover, except where the FPU is fitted to the HOB and the MSSL MGSE is in place. Failure to do this will result in damage to the A-frames)
10. Fit the Dowel retention plate.

## 10.8 Mounts onto the Optical bench

With reference to drawing A1/5264/916 – Mirror fixing envelope and the following points;

1. Put two tubular dowels into the optical bench
2. Lubricate
3. Fit the mount (note this can be applied to BSM and SMEC)

	<b>SPIRE</b>	<b>Project Document</b>	<b>Ref:</b> MSSL/SPIRE/SP006.01
		<b>Integration and Handling</b>	<b>Issue:</b> 2.0 DRAFT
			<b>Date:</b> March 2003
			<b>Page:</b> Page 22 of 23

## 10.9 Mirror on Mount

With reference to drawing A1/5264/916 – Mirror fixing envelope and the following points;

1. fit the dowel to the mount
2. Offer up the mirror, after having lubricated it with ethanol
3. Slide it with a smooth movement into the mount
4. Secure with LAM supplied nuts and washers. Torque to (TBD)

## 10.10 General Assembly

With reference to drawing A1/5264/301 – General Assembly and the following points;

1. Fit the light traps to the covers
2. Fit the thermal strap frames to the cover
3. Fit the thermal straps
4. Do not fit straps during transit

## 11. INTEGRATION

### 11.1 Integration Procedure

The integration procedure is the same for either the HOB (Herschel Optical Bench) simulator or the HOB on the spacecraft. With reference to drawing A1/5264/300 – Spire FPU Interface Drawing and the following points;

1. Fit the cone to the HOB (either on spacecraft or the plate)
2. Fit the blade mounts to the FPU
3. Lower the FPU down onto the cone
4. Secure the FPU to the Cone and the blade mounts to the HOB.



# SPIRE

## Project Document

Ref: MSSS/SPIRE/SP006.01

Issue: 2.0 DRAFT

Date: March 2003

## Integration and Handling

Page: Page 23 of 23

### APPENDIX 1

Figure 1

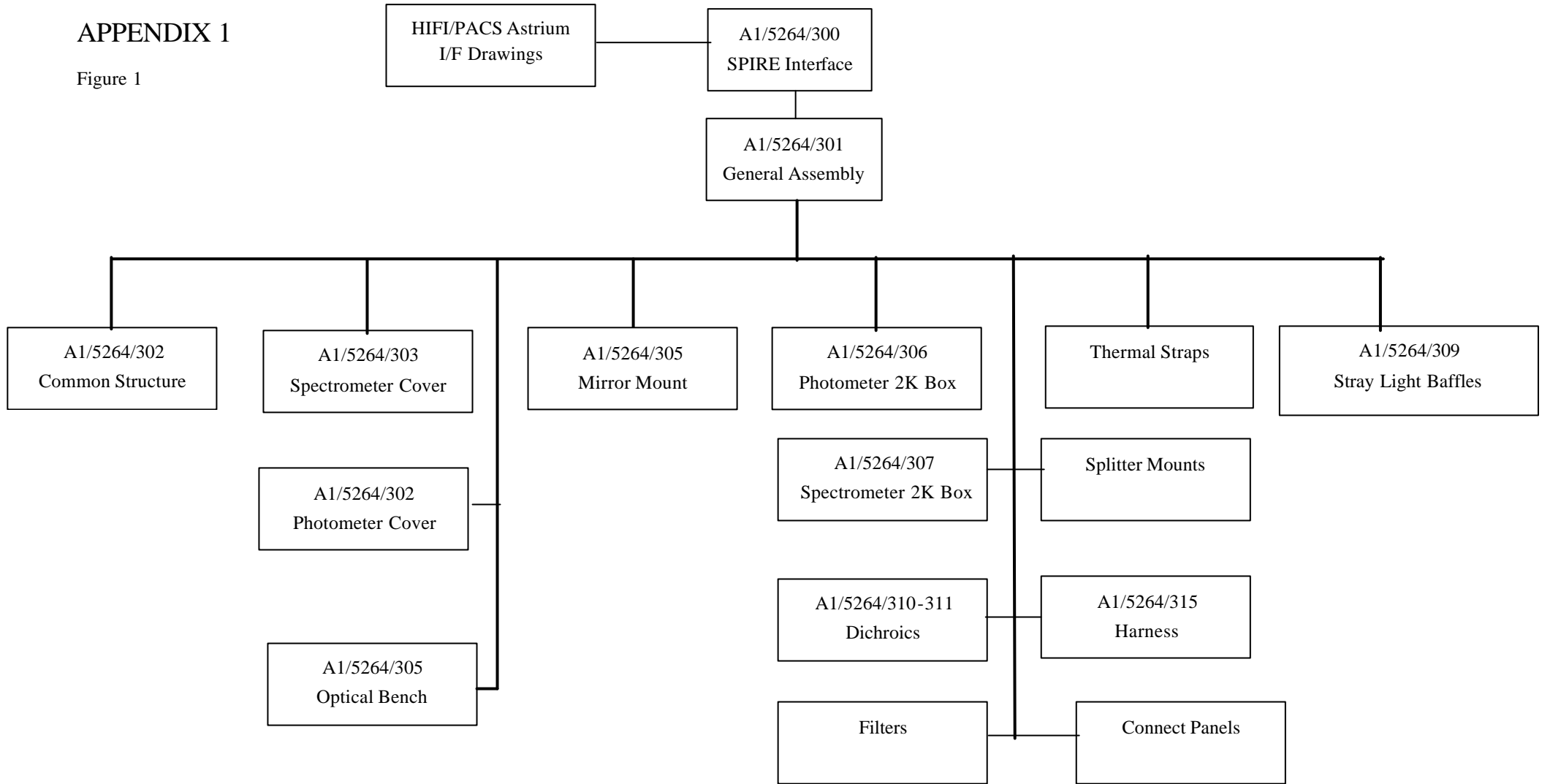

	<h1>SPIRE</h1>	Project Document	Ref:	MSSL/SPIRE/SP006.01
		Integration and Handling	Issue:	2.0 DRAFT
			Date:	March 2003
			Page:	Page 24 of 23

Dwg Level		Drawing Number	Issue	Sheets	System	Title	Material
X		A1/5264/300	17	7	SPIRE Interface	SPIRE Interface	-
	X	A2/5264/904	1	1	SPIRE Interface	Beam Splitter Mounts (Spectrometer)	-
	X	A3/5264/905	1	1	SPIRE Interface	Dichroic Mounts (Photometer)	-
	X	A3/5264/906			SPIRE Interface	Optical Bench Dimension WRT Focal Plane	-
	X	A2/5264/907	6	1	SPIRE Interface	Beam Steering Mechanism Interface	-
	X	A2/5264/908	3	1	SPIRE Interface	Cooler Interface	-
	X	A1/5264/909	3	2	SPIRE Interface	SMEC Interface	-
	X	A2/5264/910	3	1	SPIRE Interface	Spectrometer Calibrator Interface	-
	X	A3/5264/911	2	1	SPIRE Interface	Detector Interface Adapter Plate	Alum Alloy BS1470 6082 T6
	X	A1/5264/912			SPIRE Interface	Wiring Harness Spectrometer Side/Photometer Side	
	X	A3/5264/913			SPIRE Interface	Detector Focal Plane Definition	
	X	A1/5264/914	1	1	SPIRE Interface	Shutter Interface	-
	X	A3/5264/915			SPIRE Interface	4K Cooler Strap Joint & Light Baffles	
	X	A1/5264/916	1	1	SPIRE Interface	Mirror Fixing Envelope	-
	X	A1/5264/917	2	1	SPIRE Interface	RFI Filter Interface	-
	X	A2/5264/918	1	1	SPIRE Interface	PCS/PFIL 3 Interface	
	X	A2/5264/919	2	1	SPIRE Interface	SFIL - 3 Interface	
	X	A1/5264/920	4	3	SPIRE Interface	SFIL - 2 Interface	
	X	A1/5264/921	2	1	SPIRE Interface	CFIL - 1 Interface	
	X	A1/5264/922	1	1	SPIRE Interface	PFIL - 2 Interface	
	X	A1/5264/923	1	1	SPIRE Interface	Harness Hole Interface	
	X	A1/5264/924	1	1	SPIRE Interface	Interface – 4K - Baffles	
	X	A1/5264/925	2	1	SPIRE Interface	Light trap end Stops - Photometer	
	X	A1/5264/926	3	1	SPIRE Interface	Photo. Light Trap Junct. with PTC	



	<h1>SPIRE</h1>	<b>Project Document</b>	<b>Ref:</b> MSSL/SPIRE/SP006.01
		<b>Integration and Handling</b>	<b>Issue:</b> 2.0 DRAFT
			<b>Date:</b> March 2003
			<b>Page:</b> Page 25 of 23

Dwg Level	Drawing Number	Issue	Sheets	System	Title	Material
X	A1/5264/301	1	2	General Assembly	General Assembly	
	A1/5264/301-1			General Assembly		
	A1/5264/301-2			General Assembly		
	A1/5264/301-3			General Assembly		
	A1/5264/301-4	1	1	General Assembly	Cold Strap Support Leg	
	A1/5264/301-5			General Assembly		
	A1/5264/301-6			General Assembly		
	A1/5264/301-7			General Assembly		
	A1/5264/301-8			General Assembly		
	A1/5264/301-9	1	1	General Assembly	Clamp Pate	
	A1/5264/301-10	1	1	General Assembly	Cold Strap Support	
	A1/5264/301-11	1	1	General Assembly	Cold Strap Support Clamp	
	A1/5264/301-12			General Assembly		
X	A1/5264/302	1	2	Common Structure	Photometer Cover Assembly	
X	A2/5264/302-1	3	1	Common Structure	FPU Blade Mount Unit	
X	A3/5264/302-2	2	1	Common Structure	Insulating Bush	
X	A3/5264/302-3	1	1	Common Structure	Special Washer	
X	A1/5264/302-4	2	5	Common Structure	Optical Bench	
X	A1/5264/302-5	4	1	Common Structure	Fixed Mount	
X	A1/5264/302-6	6	3	Common Structure	One Piece Photometer Cover	
X	A1/5264/302-6A	1	1	Common Structure	Repair Plate	
X	A1/5264/302-7	2	1	Common Structure	Photometer Cover Bottom Seal	
X	A1/5264/302-8	2	1	Common Structure	Photometer Cover Top Seal	
X	A1/5264/302-9	2	1	Common Structure	Photometer Cover Insert	
X	A1/5264/302-10	6	2	Common Structure	Photometer Top Cover	
X	A1/5264/302-11			Common Structure	Spectrometer Cover Seal	
X	A1/5264/302-12	1	1	Common Structure	Pfil 2 Backplate	

	<h1>SPIRE</h1>	<b>Project Document</b>	<b>Ref:</b> MSSL/SPIRE/SP006.01
		<b>Integration and Handling</b>	<b>Issue:</b> 2.0 DRAFT
			<b>Date:</b> March 2003
			<b>Page:</b> Page 26 of 23

Dwg Level	Drawing Number	Issue	Sheets	System	Title	Material
X	A1/5264/302-13	1	1	Common Structure	PFIL 2 H Seal	
X	A1/5264/302-14	1	1	Common Structure	A Frame Bracket	
X	A1/5264/302-15	2	1	Common Structure	A Frame Support Plate	
X	A1/5264/302-16	1	1	Common Structure	CFIL 1 H Section	
X	A1/5264/302-17	1	1	Common Structure	PFIL2 Clamp Ring	
X	A1/5264/302-18	1	1	Common Structure	Tubular Dowel	
X	A1/5264/302-19	1	1	Common Structure	Tubular Dowel	
X	A3/5264/302-20	2	1	Common Structure	2K Interconnecting strap	
X	A3/5264/302-21	1	1	Common Structure	Cold Strap Clamp Plate	
X	A2/5264/302-22	2	1	Common Structure	BDA Connector flange – Photo.	
X	A1/5264/302-23	2	1	Common Structure	BDA connector flange – Spectro.	
X	A1/5264/302-24		1	Common Structure	Plug, BDA Connector Flange	
X	A1/5264/302-25		1	Common Structure	Harness support BDA connector	
X	A1/5264/302-26	1	1	Common Structure	A Frame Bracket (Spec)	
X	A1/5264/302-27	1	1	Common Structure	RFI Filter Frame Corner Bracket	
X	A1/5264/302-28	2	1	Common Structure	Temporary RF Bracket	
X	A1/5264/302-29	1	1	Common Structure	FRI Filter frame Edge Bracket	
X	A1/5264/302-30	2	1	Common Structure	Cooler to Photo Detector Box Strap	
X	A1/5264/302-31	2	1	Common Structure	Cooler to Spec Detector Box Strap	
X	A1/5264/302-32	3	1	Common Structure	Cooler Strap Isolation Plate	
X	A1/5264/302-33	1	1	Common Structure	Clamp Plate Photometer Strap	
X	A1/5264/302-34	1	1	Common Structure		
X	A1/5264/302-35	1	1	Common Structure	Isolating Plate Interconnecting Strap	
X	A1/5264/302-36	2	1	Common Structure	Insulating bush cooler straps	
X	A1/5264/302-37	1	1	Common Structure		
X	A1/5264/302-38	2	1	Common Structure	Insulating bush interconnecting straps	
X	A1/5264/302-39	1	1	Common Structure	Dowel retaining Plate	
X	A1/5264/302-40	1	1	Common Structure	Tubular Dowels (8mm)	

	<h1>SPIRE</h1>	<b>Project Document</b>	<b>Ref:</b> MSSL/SPIRE/SP006.01
		<b>Integration and Handling</b>	<b>Issue:</b> 2.0 DRAFT
			<b>Date:</b> March 2003
			<b>Page:</b> Page 27 of 23

Dwg Level	Drawing Number	Issue	Sheets	System	Title	Material
X	A1/5264/302-41	1	1	Common Structure	Dowel – ‘A’ Frame Support	
X	A1/5264/302-42	1	1	Common Structure	Dowel – ‘A’ Frame Top	
X	A1/5264/302-43	1	1	Common Structure	Special Washer – A Frame Bracket	
X	A1/5264/302-44	1	1	Common Structure	Blanking Plug	Alum Alloy BS1414 6082 T6
X	A1/5264/303			Spectrometer Cover	Spectrometer Cover Assembly	
X	A1/5264/303-1	2	2	Spectrometer Cover	Spectrometer Cover Wall	
X	A1/5264/303-2	1	2	Spectrometer Cover	Spectrometer Cover Lid	
X	A1/5264/303-3	1	3	Spectrometer Cover	Spectrometer Cover Baffle	
X	A1/5264/303-4	1	1	Spectrometer Cover	Spectrometer Cover Bottom Seal	
X	A1/5264/303-5	2	1	Spectrometer Cover	Spectrometer Cover Top Seal	
X	A1/5264/303-6	2	1	Spectrometer Cover	Spectrometer Baffle SM12	Alum Alloy BS1414 6082 T6
X	A1/5264/304			Photometer Cover	Photometer Cover Assembly	
	<del>A1/5264/304-1</del>			<del>Photometer Cover</del>	<del>Top Plate</del>	Not Used
	<del>A1/5264/304-2</del>			<del>Photometer Cover</del>	<del>Top Rear Plate</del>	Not Used
	<del>A1/5264/304-3</del>			<del>Photometer Cover</del>	<del>Front Plate</del>	Not Used
	<del>A1/5264/304-4</del>			<del>Photometer Cover</del>	<del>Back Plate</del>	Not Used
	<del>A1/5264/304-5</del>			<del>Photometer Cover</del>	<del>Outer Plate</del>	Not Used
X	A1/5264/304-6	6	1	Photometer Cover	CFIL 1 Baffle Mount	Alum Alloy BS1414 6082 T6
X	A2/5264/304-7	2	1	Photometer Cover	CFIL 1 Clamp Ring	Alum Alloy BS1414 6082 T6
X	A1/5264/304-8	1	1	Photometer Cover	CFIL 1 Baffle Tube	Alum Alloy BS1414 6082 T6
X	A1/5264/304-9	1	2	Photometer Cover	PFIL 2 Baffle	Alum Alloy BS1414 6082 T6
X	A1/5264/305			Optical Bench	Optical Bench Assembly	
X	A1/5264/305-1	1	1	Optical Bench	Optical Bench Harness Tie Positions	
X	A1/5264/305-2	2	1	Optical Bench	SM06 Mirror Mount	Alum Alloy BS1470 6082 T6
X	A1/5264/305-3	2	1	Optical Bench	SM07 Mirror Mount	Alum Alloy BS1470 6082 T6
X	A1/5264/305-4	1	1	Optical Bench	SM08A Mirror Mount	Alum Alloy BS1470 6082 T6
X	A1/5264/305-5	1	1	Optical Bench	SM08B Mirror Mount	Alum Alloy BS1470 6082 T6
X	A1/5264/305-6	2	1	Optical Bench	SM09A & SM10A Mirror Mount	Alum Alloy BS1470 6082 T6

	<h1>SPIRE</h1>	Project Document	Ref:	MSSL/SPIRE/SP006.01
		Integration and Handling	Issue:	2.0 DRAFT
			Date:	March 2003
			Page:	Page 28 of 23

Dwg Level	Drawing Number	Issue	Sheets	System	Title	Material
X	A1/5264/305-7	2	1	Optical Bench	SM09B & SM10B Mirror Mount	Alum Alloy BS1470 6082 T6
X	A1/5264/305-8	2	1	Optical Bench	SM11A Mirror Mount	Alum Alloy BS1470 6082 T6
X	A1/5264/305-9	1	1	Optical Bench	SM11B Mirror Mount	Alum Alloy BS1470 6082 T6
X	A1/5264/305-10	1	1	Optical Bench	SM12A Mirror Mount	Alum Alloy BS1470 6082 T6
X	A1/5264/305-11	1	1	Optical Bench	SM12B Mirror Mount	Alum Alloy BS1470 6082 T6
X	A1/5264/305-12	1	1	Optical Bench	Secondary Optical Bench (CM3/SPMOT)	Alum Alloy BS1470 6082 T6
X	A1/5264/305-13	1	1	Optical Bench	PM06 Mirror Mount	Alum Alloy BS1470 6082 T6
X	A1/5264/305-14	1	1	Optical Bench	PM08 Mirror Mount	Alum Alloy BS1470 6082 T6
X	A1/5264/305-15	1	1	Optical Bench	SM06 & SM07 Bulkhead	Alum Alloy BS1470 6082 T6
X	A3/5264/305-16	7	1	Optical Bench	Optical Reference Cube	Alum Alloy BS1470 6082 T6
X	A2/5264/305-17	1	1	Optical Bench	PM10 Mirror mount	Alum Alloy BS1470 6082 T6
X	A1/5264/305-18	1	1	Optical Bench	SM06 Mirror mount - Spare	Alum Alloy BS1470 6082 T6
X	A1/5264/305-19	1	1	Optical Bench	PM06 Mirror mount - Spare	Alum Alloy BS1470 6082 T6
X	A2/5264/305-20	4	1	Optical Bench	SFIL 2 Mount	Alum Alloy BS1470 6082 T6
X	A3/5264/305-21	2	1	Optical Bench	SFIL 2 Clamp	Alum Alloy BS1470 6082 T6
X	A3/5264/305-22	3	1	Optical Bench	SFIL 2 Cold Stop	Alum Alloy BS1470 6082 T6
X	A1/5264/305-23	3	1	Optical Bench	SBS 1 and SBS 2 Filter Mount	Alum Alloy BS1470 6082 T6
X	A2/5264/305-24	1	1	Optical Bench	SBS 1 and SBS 2 Filter Clamp	Alum Alloy BS1470 6082 T6
X	A2/5264/305-25			Optical Bench		
X	A2/5264/305-26			Optical Bench		
X	A2/5264/305-27			Optical Bench		
X	A2/5264/305-28			Optical Bench		
X	A2/5264/305-29	1	1	Optical Bench	SM9B/SBS1 Baffle	Alum Alloy BS1470 6082 T6
X	A2/5264/305-30	1	2	Optical Bench	SM9A/SBS1 Baffle	Alum Alloy BS1470 6082 T6
X	A1/5264/306	1	2	Photometer 2K Box	Photometer 2K Box Assembly	
X	A1/5264/306A	2	1	Photometer 2K Box	Photometer BDA Cable Routes	-

	<h1>SPIRE</h1>	<b>Project Document</b>		<b>Ref:</b> MSSL/SPIRE/SP006.01
		<b>Integration and Handling</b>		<b>Issue:</b> 2.0 DRAFT
				<b>Date:</b> March 2003
				<b>Page:</b> Page 29 of 23

Dwg Level		Drawing Number	Issue	Sheets	System	Title	Material
	X	A1/5264/306B	2	1	Photometer 2K Box	Photometer Bus Bar Assembly	-
	X	A1/5264/306-1	4	3	Photometer 2K Box	Back Cover	Alum Alloy BS1470 6082 T6
	X	A1/5264/306-2	6	4	Photometer 2K Box	Spine	Alum Alloy BS1470 6082 T6
	X	A1/5264/306-3	4	3	Photometer 2K Box	Front Cover	Alum Alloy BS1470 6082 T6
	X	A1/5264/306-4	1	1	Photometer 2K Box	Photometer Cold Stop Clamp	Alum Alloy BS1470 6082 T6
	X	A1/5264/306-5	2	1	Photometer 2K Box	Photometer Cold Stop	Phosper bronze
		A1/5264/306-6	1	1	Photometer 2K Box	Cable Anchor (Tie Down Points)	Alum Alloy BS1470 6082 T6
		A3/5264/306-7	2	1	Photometer 2K Box	Bus Bar Upper	OFHC Copper
		A3/5264/306-8	2	1	Photometer 2K Box	Busbar Lower	OFHC Copper
		A3/5264/306-9	1	1	Photometer 2K Box	BDA-Busbar Flange	OFHC Copper
		A3/5264/306-10	2	1	Photometer 2K Box	Bus Connector PLW	OFHC Copper
		A3/5264/306-11	2	1	Photometer 2K Box	Bus Junction ans PMW Connector	OFHC Copper
		A3/5264/306-12	2	1	Photometer 2K Box	Bus Junction Clamp Plate	OFHC Copper
		A3/5264/306-13	3	1	Photometer 2K Box	Light Trap to Bus Junction	OFHC Copper
		A3/5264/306-14	3	1	Photometer 2K Box	Bus Connector PSW	OFHC Copper
		A3/5264/306-15	1	1	Photometer 2K Box	BDA-Busbar Flange	OFHC Copper
		A3/5264/306-16	1	1	Photometer 2K Box	PLW Bus Strap	OFHC Copper
		A3/5264/306-17	1	1	Photometer 2K Box	PMW Bus Strap	OFHC Copper
		A3/5264/306-18	1	1	Photometer 2K Box	PSW Bus Strap	OFHC Copper
		A3/5264/306-19	2	1	Photometer 2K Box	End Stop Photometer Light Trap	OFHC Copper
		A3/5264/306-20	1	1	Photometer 2K Box	Light Trap Feedthrough Photometer	OFHC Copper
		A3/5264/306-21			Photometer 2K Box	Stop Bush – Bus Bar Mountings	OFHC Copper
X		A1/5264/307	1	1	Spectrometer 2K Box	Spectrometer 2K Box Assembly	Various
	X	A1/5264/307A	2	1	Spectrometer 2K Box	Spectrometer BDA Cable Routes	-
	X	A1/5264/307B	1	1	Spectrometer 2K Box	Bus Bar Assy. Spectrometer	
	X	A1/5264/307-1	4	3	Spectrometer 2K Box	Spectrometer 2K Box Assembly	Alum Alloy BS1470 6082 T6
	X	A1/5264/307-2	4	2	Spectrometer 2K Box	Filter Mounting plate Spec. 2K Box	Alum Alloy BS1470 6082 T6
	X	A1/5264/307-3	1	1	Spectrometer 2K Box	Clamp plate SFIL-3	Stainless Steel BS970 303/S31

	<h1 style="margin: 0;">SPIRE</h1>	<b>Project Document</b>		<b>Ref:</b>	MSSL/SPIRE/SP006.01
		<b>Integration and Handling</b>		<b>Issue:</b>	2.0 DRAFT
				<b>Date:</b>	March 2003
				<b>Page:</b>	Page 30 of 23

Dwg Level		Drawing Number	Issue	Sheets	System	Title	Material
	X	A1/5264/307-4	2	1	Spectrometer 2K Box	Blade Mount 2K Spectrometer Box	Stainless Steel BS970 303/S31
	X	A1/5264/307-5	1	1	Spectrometer 2K Box	Blade Top Bush	Stainless Steel BS970 303/S31
	X	A1/5264/307-6	1	1	Spectrometer 2K Box	Light Trap Feedthrough spect.	
	X	A1/5264/307-7	1	1	Spectrometer 2K Box	Light Baffle Junction	
	X	A1/5264/307-8	1	1	Spectrometer 2K Box	SSW Spect. BDA to light trap strap	
	X	A1/5264/307-9	1	1	Spectrometer 2K Box	SLW Spect. BDA to Light Trap Strap	
	X	A1/5264/307-10	1	1	Spectrometer 2K Box	BDA Cold Interface Spectrometer	
	X	A1/5264/307-11	1	1	Spectrometer 2K Box	Bush, Inner spect. Light Trap	
	X	A1/5264/307-12	1	1	Spectrometer 2K Box	Bush, Outer spect. Light Trap	
	X	A1/5264/307-13	1	1	Spectrometer 2K Box	Cold Strap Support	
X		A3/5264/309	3	1	Level 0 Feed Thorough	Strap/Light Baffle Assembly	
	X	A3/5264/309-1	2	1	Level 0 Feed Thorough	Baffle Inner	
	X	A3/5264/309-2	2	1	Level 0 Feed Thorough	Baffle Outer	
	X	A3/5264/309-3	2	1	Level 0 Feed Thorough	Junction Plate Inner	
	X	A3/5264/309-4	2	1	Level 0 Feed Thorough	Junction Plate Outer	
	X	A3/5264/309-5	1	1	Level 0 Feed Thorough	Anti Torque Plate	
	X	A3/5264/309-6	1	1	Level 0 Feed Thorough	Special Washer	
	X	A3/5264/309-7	1	1	Level 0 Feed Thorough	Stop Screw	
X		A2/5264/310	1	1	Dichroics	PDIC-1 Assv	-
	X	A2/5264/310-1	2	1	Dichroics	PDIC-1 Mount	Alum Alloy BS1470 6082 T6
	X	A2/5264/310-2	1	1	Dichroics	PDIC-1 Clamp Ring	Alum Alloy BS1470 6082 T6
	X	A2/5264/310-3	2	1	Dichroics	Dowel Bolt 6-32 UNC	Stainless Steel BS970 303/S31
	X	A2/5264/311	1	1	Dichroics	PDIC-2 Assv	-
	X	A2/5264/311-1	2	1	Dichroics	PDIC-2 Mount	Alum Alloy BS1470 6082 T6
	X	A2/5264/311-2	1	1	Dichroics	PDIC-2 Clamp Ring	Alum Alloy BS1470 6082 T6
X		A2/5264/312	1	1	Photometer 2K Box	Cone Mount – 2K Photometer Box	Stainless Steel BS970 321/S31
X		A2/5264/313	2	1	Photometer 2K Box	A Frame Mount 2K Photometer Box	Stainless Steel BS970 321/S31

	<b>SPIRE</b>	<b>Project Document</b>	<b>Ref:</b> MSSL/SPIRE/SP006.01
			<b>Issue:</b> 2.0 DRAFT
		<b>Integration and Handling</b>	<b>Date:</b> March 2003
			<b>Page:</b> Page 31 of 23

Dwg Level		Drawing Number	Issue	Sheets	System	Title	Material
	X	A3/5264/313-1	1	1	Photometer 2K Box	Blade Washer 2K	Stainless Steel BS970 321/S31
	X	A3/5264/313-2	1	1	Photometer 2K Box	Blade top bush	Stainless Steel BS970 321/S31
X		A3/5264/314	1	2	SCAL Box	SCAL Box Assembly	Alum Alloy BS1470 6082 T6
	X	A3/5264/314-1	4	2	SCAL Box	SCAL Baffle Box Main Body	Alum Alloy BS1470 6082 T6
	X	A3/5264/314-2	1	1	SCAL Box	SCAL Cover	Alum Alloy BS1470 6082 T6
	X	A3/5264/314-3	1	1	SCAL Box	SCAL Baffle Riing	Alum Alloy BS1470 6082 T6
	X	A3/5264/314-4	1	1	SCAL Box	SCAL Baffle Mask	Phosphor Bronze
	X	A3/5264/314-5	1	1	SCAL Box	SCAL Baffle Box internal wall	Alum Alloy BS1470 6082 T6
X		A1/5264/315			Harness	Harness Assembly	
	X	A1/5264/315-1	1	1	Harness	BSM Harness 1 Assembly	
	X	A1/5264/315-2	1	1	Harness	BSM Harness 2 Assembly	
	X	A1/5264/315-3	1	1	Hamess	BSM Assembly General Views	