



**HERSCHEL**  
**SPIRE**

Ref: **SPIRE-RAL-DOC-001578**

Author: **D.L. Smith**

Page: **1**

Issue: **1.0**

Date: **17-Jun-2003**

## SPIRE Cold Optical Alignment Procedure

**Prepared by:**

**D.L. Smith (RAL)**

Date

Approved  
by Default

19th August 2003

**Checked:**

**B.J. Swinyard (RAL)**

Date

**Checked:**

**M. Ferlet (RAL)**

Date

Approved  
by Default

19th August 2003

**Approval:**

**E. Sawyer (RAL)**

Date



## Distribution

**RAL** Eric Sawyer  
Mike Trower  
Eric Clark  
Alan Pearce  
Anne Sophie Goizel  
Marc Ferlet

**LAM** Alain Origne  
Kjetil Dohlen

Host system	Windows 2000 SP2
Word Processor	Microsoft Word 2000 SR1
File	Cold Alignment Test Procedure.Doc



### Document Change Record

Date	Index	Affected Pages	Changes
11-April-2003	0.1	All	First Draft
9-May-2003	0.2	All	Alignment sequence included
17-Jun-2003	1.0	6 9, 10,11	First issue for cold alignment trials More details about window and alignment cubes Reordering of warm alignment check to be performed in vacuum.



## 1 Scope of Document

This procedure covers the cold alignment verification test campaign, which is a key inspection point (AD 1). The details of the instrument integration and cryostat operations are given in AD 3 and AD 4 respectively. The optical alignment procedures follow the SPIRE optical alignment plan and procedures (AD 2 and AD 5).

## 2 Documents

### 2.1 Applicable Documents

	Title	Author	Reference	Date
AD 1	SPIRE STM Instrument Level Test Plan	D.L.Smith	SPIRE-RAL-DOC-001048 Issue 1.0	15-May-2003
AD 2	SPIRE Optical Alignment Plan	Alain Origne, Kjetil Dohlen	LOOM.KD.SPIRE.2000.001-1	
AD 3	SPIRE Cryostat Integration Procedures	D.L. Smith		
AD 4	SPIRE Cryostat Operating Procedures	D.L.Smith	SPIRE-RAL-DOC-001556 Issue 0.2	24-Mar-2003
AD 5	SPIRE Alignment Sequence	Alain Origne, Kjetil Dohlen	Draft 04.xls	27-Sep-2002
AD 6	SPIRE Cleanliness Plan	B.J. Swinyard	SPIRE-RAL-DOC-001070 Issue 1.0	9-Jan-2002
AD 7	RAL Safety Codes	CCLRC	<a href="http://www-internal.clrc.ac.uk/staff/notices/ral_safety_codes">http://www-internal.clrc.ac.uk/staff/notices/ral_safety_codes</a> .	

### 2.2 Reference Documents

	Title	Author	Reference	Date
RD 1	SPIRE Cryostat Operating Manual	AS Scientific	SPIRE-RAL-DOC-001472 Issue 1.0	08-Jan-2002

### 3 Test Configuration

#### 3.1 Cryostat

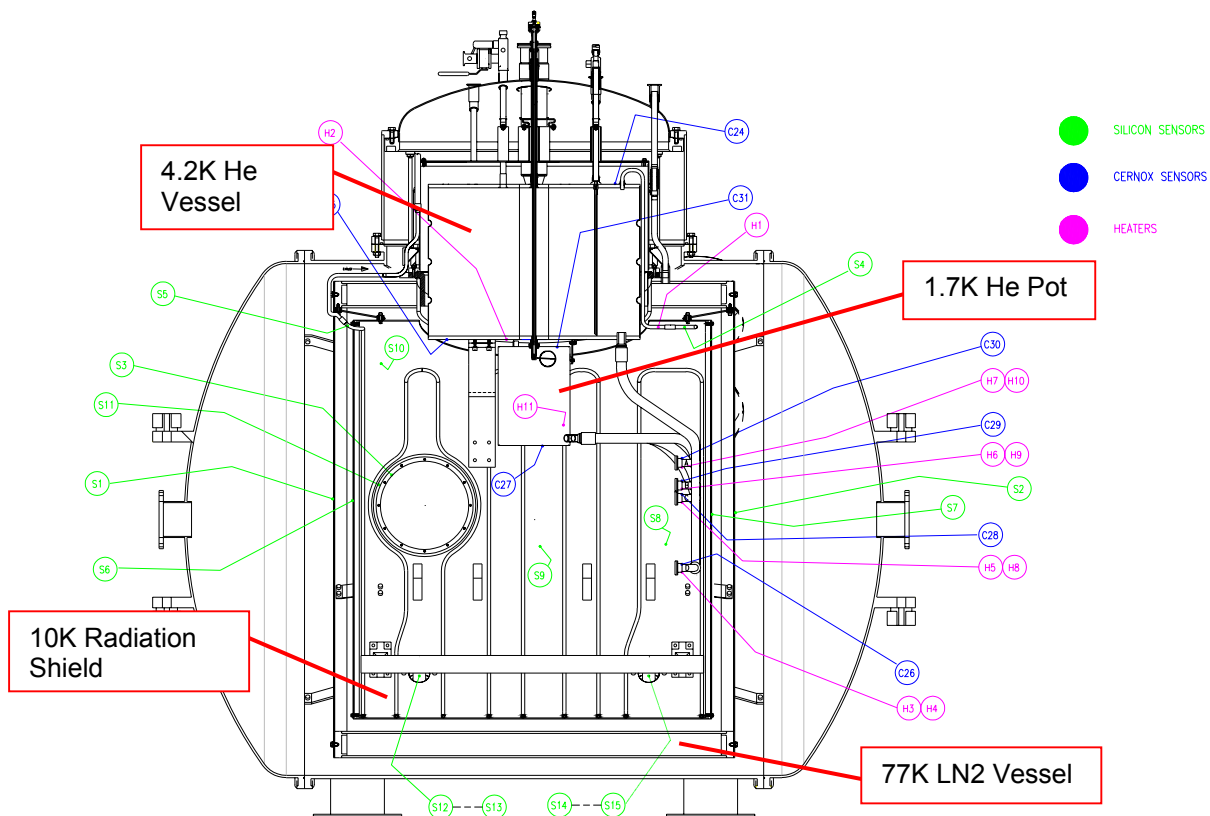

**Figure 1:** Cross section of SPIRE test cryostat showing the different temperature stages and thermometer locations (Drawing ref RD 1).

The SPIRE Calibration Cryostat has four stages of cooling, an outer liquid nitrogen cooled vessel at 77K, a 9K radiation shield, a 4.2K liquid He vessel and a 1.7K pumped liquid He pot, Figure 1. A more detailed description of the cryostat and its operation is given in AD 4 and RD 1.

### 3.2 Optical Layout

The following diagrams show the configuration of the OGSE for the cold optical alignment. It should be noted that the RAL-HOB and HOR are not made to be absolute references, so only serve as relative references. Although the cryostat window may not be optically flat, it is assumed that it will not change shape between hot and cold vacuum. It can therefore serve locally as reference surface. The instrument will move and change orientation on cool-down. This test verifies the relative orientation of HOR and SOR.

#### LAM theodilte mount

(all dimensions in mm)

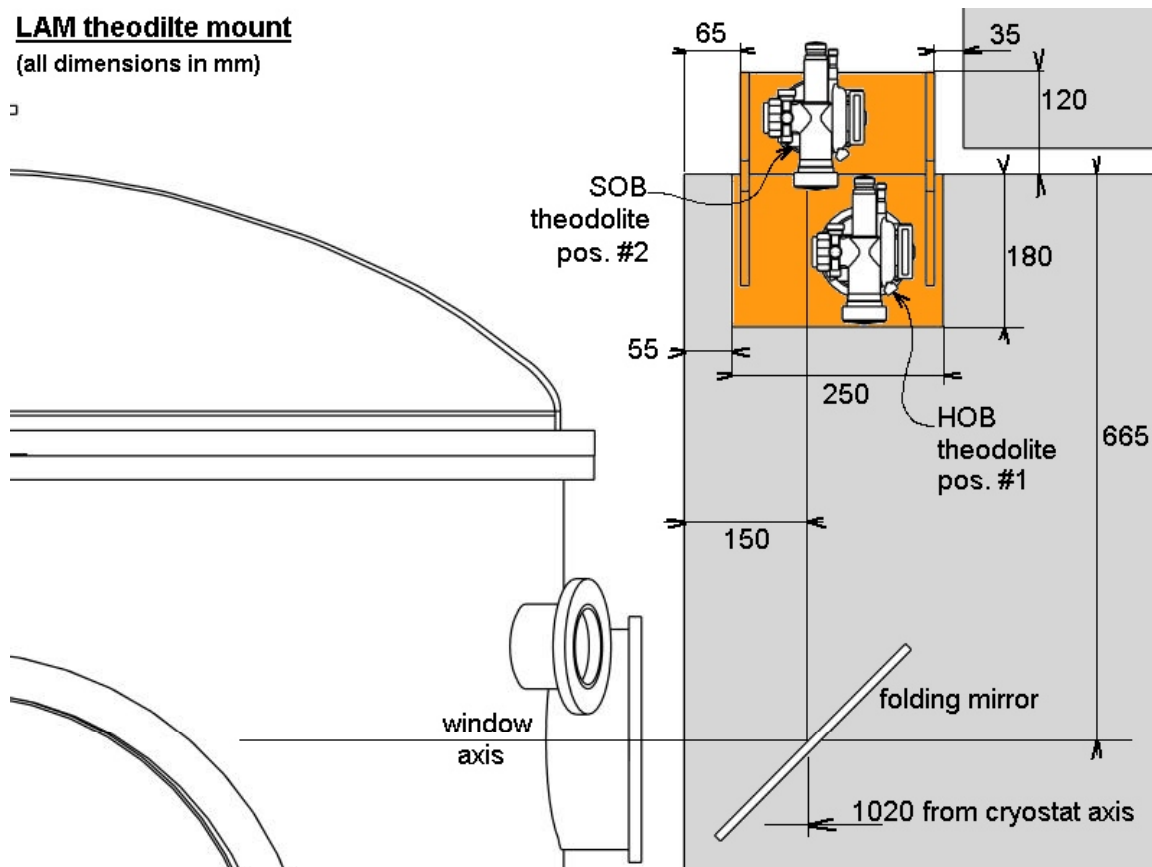

Figure 2: Illustration of the OGSE configuration of steps 3.1 and 3.2 of the procedure (theodolites pointing towards the cubes SC1 on SOB and HC1 & HC2 on HOB simulator plate)

The cryostat window has a wedge on front surface which can be taken out by the front fold mirror (i.e. not set at 45deg AOI). Theoretically, the reference cubes top surfaces should be approximately parallel to the cryostat window back surface which is therefore the more likely one to be used for auto-collimation reference. None of the window surfaces are AR coated.

The alignment cube HC2 on HOB simulator plate is just used for the Tel.Sim. set-up. Only the HOR cube (HC1) and the SOR cube (SC1) are expected to be used for cold alignment verification.

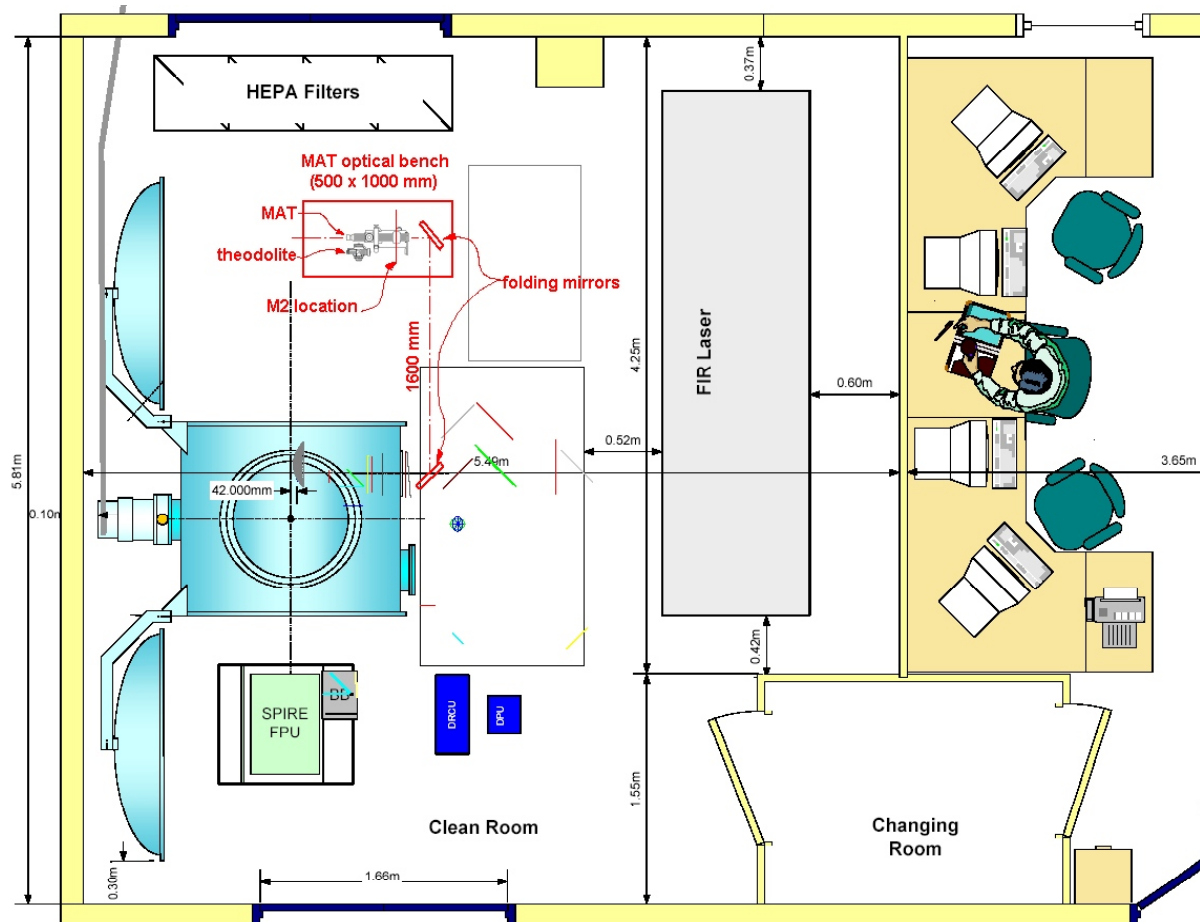

Figure 3: Illustration of the OGSE configuration for the pupil imaging test (with MAT and M2 tool)



## 4 Constraints

### 4.1 Safety

Great care should be taken when handling liquid nitrogen and helium. The main hazards associated with liquid Nitrogen and Helium are:

- Cold "burns" to the person.
- Explosions due to the vaporization of the liquified gas into an enclosed space.
- Asphyxiation due to exclusion of oxygen.
- Spillage onto structural materials, which can cause thermal contraction of the metal, say steelwork, with resultant cracking.

All people working with the cryostat should have instruction on the safe handling of cryogenic liquids and familiarise themselves with the laboratory safety code RALSC10 which can be found on [http://www-internal.clrc.ac.uk/staff/notices/ral\\_safety\\_codes](http://www-internal.clrc.ac.uk/staff/notices/ral_safety_codes). The safety code must be followed at all times when handling cryogenic liquids. A risk assessment shall be performed before operating the cryostat.

The personal oxygen monitors provided must be used when entering the lab when the cryostat is cold. These are calibrated **every 6 months by the manufacturers (crowcon in Abingdon)**.

When the oxygen monitor alarm sounds leave the room immediately and call ext 5996. DO NOT attempt to enter the room afterwards until the all clear has been given.

The gloves provided shall be worn when transferring liquid helium and nitrogen into the tank.

Any dewars with worn or damaged castors or which are difficult to wheel safely should be taken out of service and returned to stores immediately for repair or maintenance.

The cryostat vacuum window presents a particular hazard and must be used with extreme caution. Because of its size (300mm diameter), a small fracture could cause catastrophic failure and may result in serious injury or loss of life. A stress analysis has been performed prior to use (ref: ) and if used carefully will withstand the stresses induced by the pressure difference between atmosphere and vacuum. However, tapping the glass with hard objects (e.g. a screwdriver) could induce micro-fractures that will propagate resulting in failure of the window. To reduce the risks, a Perspex screen will be placed in front of the window so that accidental contact can be avoided and prevent glass flying if the window should fail.





### 5 Procedure Flowchart

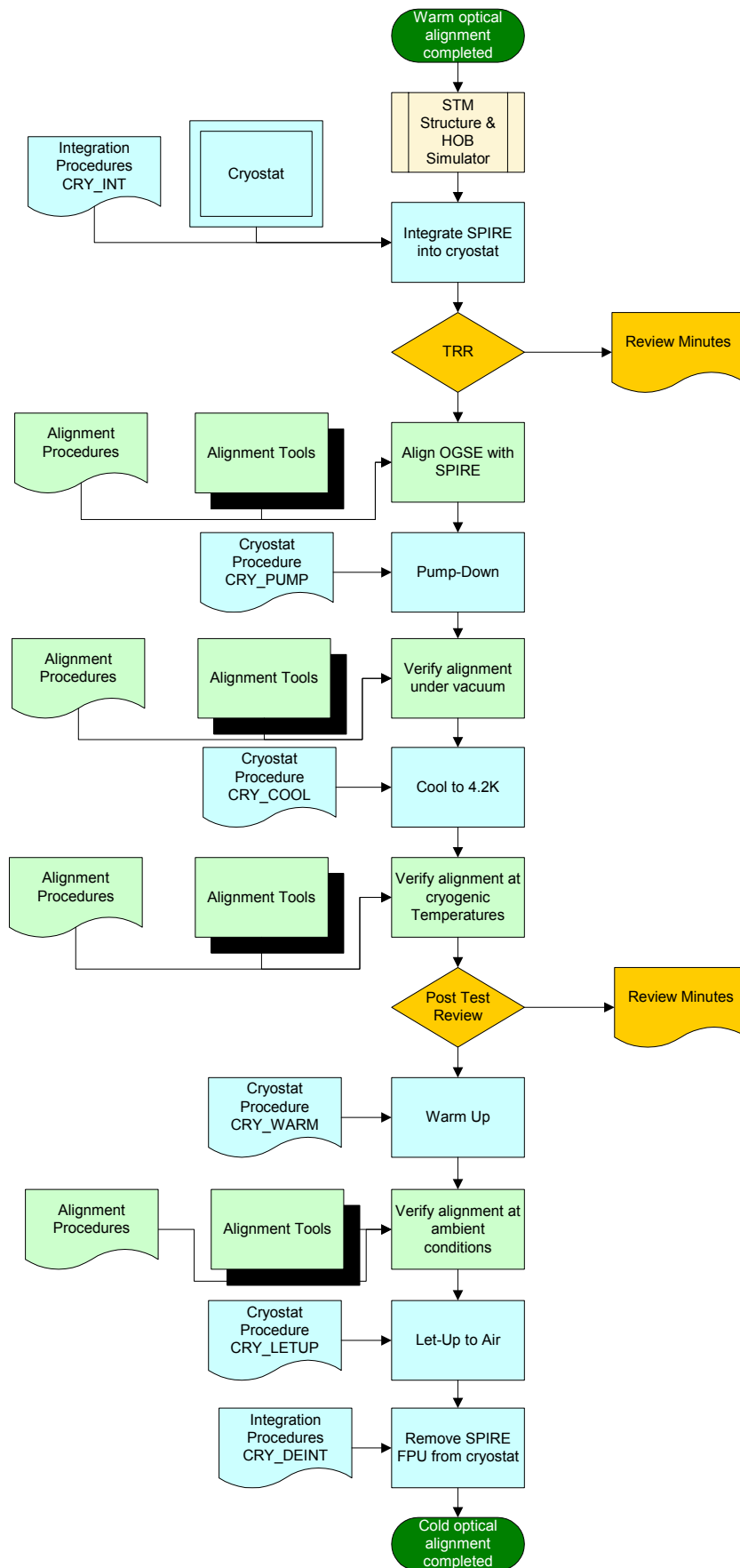



## 6 Test Procedure

---

<b>Objective:</b>	To verify SPIRE optical alignment at cryogenic temperatures.  This is a key inspection point.
<b>Initial Conditions:</b>	SPIRE mounted on RAL-HOB simulator with Herschel Optical Reference cubes (HOR)  Chamber at Atmospheric Pressure (~1000mbar) Tank doors open Vacuum system control electronics OFF Turbo Pump fan unit power OFF N2 supply closed 3 Phase supply OFF TFCS Logging OFF
<b>Final Conditions:</b>	As before
<b>Constraints:</b>	Pumping must not start until a test readiness review has been held and authorisation to proceed has been given.
<b>Total Duration:</b>	17 days (estimated)

---

Step.	Action	Task Complete
<b>1</b>	<b>Integrate SPIRE into Cryostat</b>	
1.1	Install SPIRE into chamber using procedure CRY_INT (ref AD 3)	
<b>2</b>	<b>Hold Test Readiness Review</b>	
2.1	Required Personnel  AIV Manager – Dave Smith PA Manager – Eric Clark Alignment Specialists – Marc Ferlet, Alain Origne	
<b>3</b>	<b>Run Through Alignment Procedure</b>	
3.1	Mount theodolite onto telescope simulator bench facing HOR. Adjust for autocollimation on HOR. Adjust for autocollimation on cryostat window. Record difference in theodolite orientation.	
3.2	Mount theodolite onto telescope simulator bench facing SOR. Adjust for autocollimation on SOR. Adjust for autocollimation on cryostat window. Record difference in theodolite orientation	
3.3	Align measurement alignment telescope (MAT) to HOR.	
3.4	Align MAT to photometer gut ray central D tool source is lit. Focus on CS tool. Record deviation.	
3.5	Align MAT to spectrometer gut ray, one D tool source is lit, focus on CS tool. Record deviation. Repeat for other D tool	
3.6	Focus on D tool, record deviation. Repeat for other D tool.	



<b>4</b>	<b>Pump-Down Cryostat</b>	
	Start cryostat pump-down using procedure CRY_PUMP (ref AD 4)	
<b>5</b>	<b>Perform Warm Optical Alignment</b>	
5.1	Mount theodolite onto telescope simulator bench facing HOR. Adjust for autocollimation on HOR. Adjust for autocollimation on cryostat window. Record difference in theodolite orientation.	
5.2	Mount theodolite onto telescope simulator bench facing SOR. Adjust for autocollimation on SOR. Adjust for autocollimation on cryostat window. Record difference in theodolite orientation	
5.3	Align measurement alignment telescope (MAT) to HOR.	
5.4	Align MAT to photometer gut ray central D tool source is lit. Focus on CS tool. Record deviation.	
5.5	Align MAT to spectrometer gut ray, one D tool source is lit, focus on CS tool. Record deviation. Repeat for other D tool	
5.6	Focus on D tool, record deviation. Repeat for other D tool.	
<b>6</b>	<b>Cool instrument to 4.2K</b>	
	Cool SPIRE to 4.2K using procedure CRY_COOL (ref AD 4)	
<b>7</b>	<b>Perform Cold Optical Alignment</b>	
7.1	Align MAT to HOR.	
7.2	Align MAT to photometer gut ray central D tool source is lit. Focus on CS tool. Record deviation.	
7.3	Align MAT to spectrometer gut ray, one D tool source is lit, focus on CS tool. Record deviation. Repeat for other D tool	
7.4	Focus on D tool, record deviation. Repeat for other D tool.	
7.5	Compare results with those obtained in step 3.	
<b>8</b>	<b>Post Test Review</b>	
	Review the results of the cold tests before warming up the cryostat. Required Personnel AIV Manager – Dave Smith PA Manager – Eric Clark Alignment Specialists – Alain Origne, Marc Ferlet	
<b>9</b>	<b>Warm Up</b>	
	Warm SPIRE to ambient using procedure CRY_WARM (ref AD 4)	
<b>10</b>	<b>Warm Optical Alignment Check</b>	
10.1	Align MAT to HOR.	
10.2	Align MAT to photometer gut ray central D tool source is lit. Focus on CS tool. Record deviation.	
10.3	Align MAT to spectrometer gut ray, one D tool source is lit, focus on CS tool. Record deviation. Repeat for other D tool	
10.4	Focus on D tool, record deviation. Repeat for other D tool.	
10.5	Compare results with those obtained in step 3. and 6.	



11	<b>Let Up to Atmosphere</b>	
	Let up chamber to atmospheric pressure using procedure CRY_LETUP (ref AD 4)	
12	<b>Remove SPIRE from Cryostat</b>	
12.1	Remove SPIRE from chamber using procedure ref. CRY_DEINT (ref: AD 3)	