

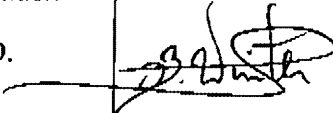

**Minutes of Meeting**

**Herschel**

Date:	27/09/02	Chairman:	Horst Faas
Doc.-No.:	HP-2-ASED-MN-0182	Secretary:	Horst Faas
Meeting place:	ASED, Friedrichshafen	Close of Meeting:	Close of Meeting
Date/Time:	27/09/02 / 09h00		
Agenda dated:	See attached		

Subject: Mech. Interface Meeting with Spire

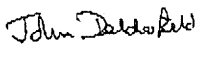
Participants:	RAL/MSSL: J. Delderfield, B. Winter, J. Coker	Additional Distribution: Dr. Moritz, W. Ruhe, E. Holzle, J. Lang, J. Kroeker
	ASED: H. Faas, D. Tenhaeff, J. Hinger, HW Peltz, A. Mauch	
	O. Stauss, A. Hauser, D. Schink (p/t)	
		
		
		2002.09.30 08:24:31 +01'00'

Page: 1 of 8 Page(s) plus Annex 1, 2 and 3

<input type="checkbox"/> Brief-Minutes (except following sheets)	<input type="checkbox"/> Summary of Results of Sheets 2 till
--	--



## Minutes of Meeting

## Herschel

Date:	27/09/02		
Doc.-No.:	HP-2-ASED-MN-0182		
Meeting place:	ASED, Friedrichshafen	Chairman:	Horst Faas
Date/Time:	27/09/02 / 09h00	Secretary	Horst Faas
Agenda dated:	See attached	Close of Meeting:	Close of Meeting

Subject: Mech. Interface Meeting with Spire

Participants:	RAL/MSSL: J. Delderfield, B. Winter, J. Coker  ASED: H. Faas, D. Tenhaeff, J. Hinger, HW Peltz, A. Mauch  O. Stauss, A. Hauser, D. Schink (p/t)	Additional Distribution: Dr. Moritz, W. Rühle, E. Hölzle, J. Lang, J. Kroeker
---------------	---	---

Page: 1 of 8 Page(s) plus Annex 1, 2 and 3

<input type="checkbox"/> Brief-Minutes (except following sheets)	<input type="checkbox"/> Summary of Results of Sheets 2 till
--	--

Reference	Results	Remarks
	<p>The updated draft agenda in shown in <b>Annex 1</b></p> <p><b>Comments to Spire IF Drawings</b>            The list of comments provided by Astrium in provided in <b>Annex 2</b>.</p> <p>Cryostat opening is 288mm instead of 270mm</p> <p>Level-1 IF M3 FPU IF: Astrium assumed a standard M5 ISO I/F. Astrium believes that the M3 IF is worst than the ISO M5 IF.            Another possibility would be to use the M8 MGSE I/F.</p> <p>It is planned to split the Level-1 strap in two straps to improve thermal performance. This has to be considered in the design.</p> <p>Astrium will compare the pretension load (cold conditions ) for the standard ISO to the M3 IF proposed by Spire.</p> <p>Two design options are possible:</p> <ul style="list-style-type: none"> <li>• Via the 4 M3 IF screws</li> <li>• Via the M8 screw IF</li> </ul> <p>As a second step the thermal implication need to be evaluated.</p> <p><b>Alignment Cube:</b>            Two issues were discussed:</p> <ul style="list-style-type: none"> <li>• Move cube up by 12.5mm in x-direction to allow alignment to the HOB</li> <li>• Dismounting capability of the alignment cube</li> </ul> <p>A solution would be to move the cross hair to the upper part of the cube.</p> <p>The requirement for max. allowable offset of the cube should be less then 2 arc. min., <b>fixed to &lt;5 arc sec.</b></p> <p>Astrium reached an accuracy of 3 arc sec, using the presented adjustment plate.</p> <p>The Astrium baffle was designed to optimise the thermal performance. The alignment cube would decrease the thermal optimisation.</p>	<p>Action #1 MSSL:            Provide allowable IF force and torque at the level-1 IF. (due: 4/10/02)</p> <p>Action #2 ASED/DT:            Astrium will compare the pretension load (cold conditions ) for the standard ISO to the M3 IF proposed by Spire. (due: 10/10/02)</p> <p>Action #3: RAL/JD to evaluate the IF to optimise the thermal IF.(4/10/02)</p> <p>Action #4: ASED/JH to evaluate the IF to optimise the thermal IF.(7/10/02)</p> <p>Action #5: MSSL/BW:            Move the centre of the cross hair <b>to</b> 5mm from the top of the cube in the centre of the cube (+z side of the cube).</p> <p>Action #6: MSSL/BW to look into the possibility to make the alignment cube dismountable, considering the allowed</p>

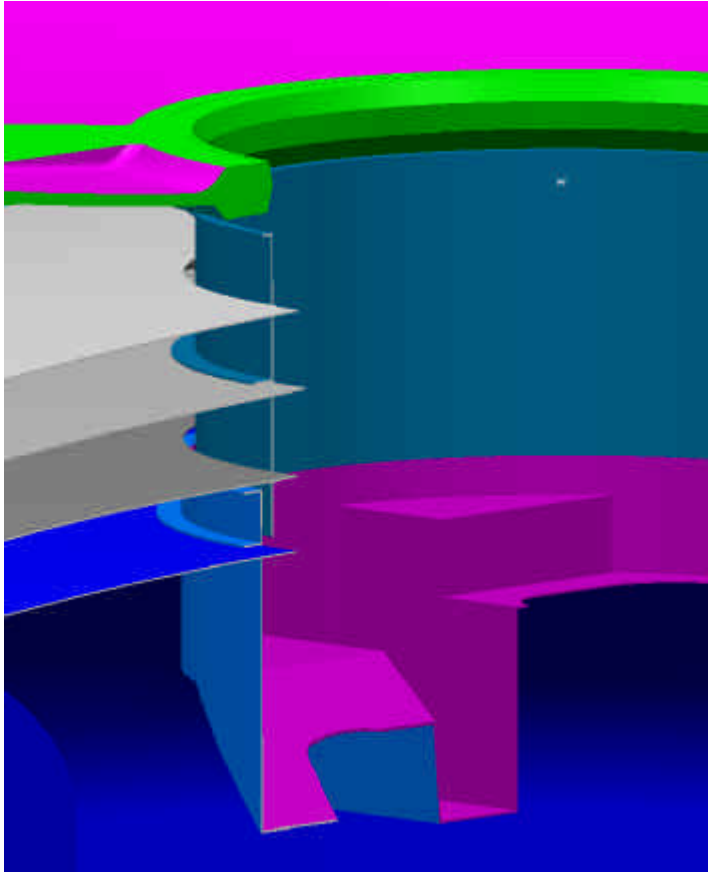
Reference	Results	Remarks
	 <p data-bbox="424 1312 1062 1379">Sketch of instrument shield and instrument baffle below cryostat entrance</p> <p data-bbox="424 1447 1110 1514">The beam definition in the IF drawings is considered as not sufficient.</p> <p data-bbox="424 1547 1126 1749">Changing the surface on the inside of the cryo cover heat shield, Astrium suggested to possibility that the area viewed by the instrument would be black, but the remainder would be made of low emissivity (gold). Spire to comment. This couples with the instrument shield baffle.</p> <p data-bbox="424 1816 1102 1883">RAL should clarify how the SPIRE red tagged cover should be represented in the IF drawings.</p> <p data-bbox="424 1917 1094 1984">Astrium would be like to have the updated IF drawings for the Kick-off of the OBA subcontractor,</p>	<p data-bbox="1145 349 1278 371">accuracy.</p> <p data-bbox="1145 1447 1469 1559">Action #7 MSSL/BW: Send the entrance beam in Step format</p> <p data-bbox="1145 1626 1469 1727">Action #8: ASED to send the Step file of the instrument shield baffle.</p> <div data-bbox="1145 1805 1469 1973" style="border: 1px solid black; padding: 5px;"> <p data-bbox="1145 1816 1334 1850">Action MSSL</p> </div>

Reference	Results	Remarks
	<p>which takes place in the second half of October. The OB plate IF should therefore be fixed by mid October.</p> <p>An open issue may the required stand-offs for the Spire harness, needed as a consequence if the Level-3 straps are implemented. This interface to the OB plate can be fixed at this stage. This change could be implemented as part of the Level-3 <b>implementation which is still being worked through.</b></p> <p><b>LEVEL-0 Straps</b>            ASED presented the Level-0 displacement analysis (see <b>Annex 3</b>). A total displacement of 10mm in the failure case would be possible.</p> <p>The following option for the Level-0 I/F is proposed for further investigation:</p> <p>The I/F would moved down directly to the Alu Studs. The ASED flexible link would be removed and the displacement would be handled by Spire's upper braids higher up.</p> <p>ASED would provide the fixation elements for the level-0 interface to the Alu cones.</p> <p><b>LEVEL-1 Straps</b>            Spire and ASED need to define and agree the electrical insulation following the agreement on the mech IF (i.e.M3 / M5 /M8 issue).</p> <p><b>Level-3 Straps</b>            If these straps are introduced by ASED as a result of the updated IF temperatures (new ECR#9), the electrical insulation need to be clarified . The mech. IF will be based on ISO, <b>see JFET I/F drwgs.</b>            The fixation elements would be supplied by Spire. <b>For JFET rack position see Sheet 2 of 7 of IF drawings and the JFET IF Drawings to derive the Level 3 strap positions.</b></p> <p><b>Fixation of FPU and JFET to HOB plate</b>            ASED need to know the loads for all the bolts and the analysis results how they have been derived.</p>	<p>Action #9 ASED (HWP and DT): provide the positions of the Level-0 Interfaces and the displacement and rotations of these interfaces. Due: 9/10/02</p> <p>Action #10 RAL/MSSL (BW) will evaluate the feasibility of the proposed design</p> <p>Action #11 RAL/MSSL (BW) to provide the loads for all bolts. Due: 30/10/02</p> <p>Action #12 ASED:</p>

Reference	Results	Remarks
	<p>MSSL need to provide the height of the pivots of the A-frame (in the IF drawings).</p> <p>RAL/MSSL will provide the fixation bolts and washers for the FPU and the JFETS. ASED will provide the tapping depth in the HOB plate. 2d heli coil preferable.            Stainless steel bolts are used.            Venting provision is covered by the Herschel Optical bench.</p> <p><b>JFET fixation:</b>            In order to achieve the Level-3 connection a thermal impedance of 0.002W/K (total) for each of the two JFET assemblies <b>is in the thermal modelling</b>.</p> <p><b>Use of shimming plates and dowel pins</b>            Spire has not foreseen shimming plates. Spire is not required to be as sensitive to height as PACS.</p> <p>SPIRE considers that their instrument will not be delivered with any internal misalignment. The A-frame have been qualified about 2 years ago and no provision for shimming was foreseen.</p> <p>Spire notes that instrument mounting points are on raised pads on the HOB plate. SPIRE cannot introduce the height required for 3mm shim into its feet. A possible approach would be to lower the pads by 3mm. SPIRE nominal IF plane remains unchanged.</p> <p>Dowel pins: The IID-A requirement was introduced to allow re-produceable mounting.</p> <p>Spire proposes to use shoulder bolts instead of dowel pins, which guarantees re-produceable <b>cold</b> mounting of the FPU.</p> <p>The Spire IF drawings Sheet 4 of 7 should include tolerances. Spire should put a positional tolerance on the position of the cone. Spire to review the tilt spec across its mountings.</p> <p><b>Bonding straps</b>            No bonding straps are required by Spire in flight. However, Spire includes static sensitive items!</p>	<p>Provide tapping depth in the HOB plate. Due: 11/10/02</p>

Reference	Results	Remarks
	<p><b>Instrument handling</b>            MSSL presented the hoisting device (with the Optical Bench simulator) and the MSGE for installation on the HOB plate (see Annex 4).            ASED will investigate the available space on the FPU A-frame side to allow an additional MGSE to secure the A-frames.</p> <p>Spire may wish to bring the complete integrated FPU and JFETS (including linking harness) assembly down to the HOB (tbc). The harness detailed design is ongoing and the ability to demount the JFET from the FPU will be an aim. If this is possible Spire can relax this option. RAL to confirm the schedule by 4/10/02.</p> <p><b>Harness Routing</b>            It is anticipated that the harness to the FPU will need to be stood off from the HOB. The thermal model assumes a length of 200 to 300mm of thermal decoupling from the HOB.            ASED are progressing the design in this area and likewise for the harness leaving the JFETs towards the CVV connectors.</p> <p>The present baseline is that the harness between the JFETs and the FPU will be self supporting between the units. If the Level-3 calculations show that the JFET unit temperature raise greater than 15K (TBC) it may be necessary to weakly heat sink these harness to the HOB. Any strap required would be Spire supplied, but the required bolt holes in the HOB need to be foreseen by ASED.</p> <p>AI 002, HP-2-ASED-MN-0107 was closed with the analysis performed by Spire (Shutter TN provided)</p> <p>AI006, HP-2-ASPI-MN-1725 was closed, ASED has got the required information.</p> <p>AI concerning the review of the ASED integration TN.            New due date: 30/10/02</p>	

Meeting: HP-2-ASED-MN-0182

Title: Mech IF Meeting with SPIRE

Date: 27/09/02

## Action Item List

Herschel

No.:	Description:	Due Date	Originator Comp./Pers.	Actionee Comp./Pers.	Source	Completion
#1	Action #1 MSSL: Provide allowable IF force and torque at the level-1 IF.	4/10/02	ASED / H Faas	RAL/MSSL B. Winter		
#2	Action #2 ASED/DT: Astrium will compare the pretension load (cold conditions ) for the standard ISO to the M3 IF proposed by Spire.	10/10/02	RAL / J Delderfield	ASED / D. Tenhaeff		
#3	Action #3: RAL/JD to evaluate the IF to optimise the thermal IF	4/10/02	ASED / H Faas	RAL / J Delderfield		
#4	Action #4: ASED/JH to evaluate the IF to optimise the thermal IF.	7/10/02	RAL / JD	ASED / J Hinger		
#5	Action #5: MSSL/BW: Move the centre of the cross hair 5mm from the top of the cube in the centre of the cube (+z side of the cube).	30/10/02	ASED / H Faas	RAL/MSSL, B. Winter		
#6	Action #6: MSSL/BW to look into the possibility to make the alignment cube dismountable, considering the allowed accuracy.	7/10/02	ASED / H Faas	RAL/MSSL, B. Winter		
#7	Action #7 MSSL/BW: Send the entrance beam in Step format	30/10/02	ASED / H Faas	RAL/MSSL, B. Winter		
#8	Action #8: ASED to send the Step file of the instrument shield baffle.	2/10/02	MSSL / B Winter	ASED / O. Stauss		
#9	Action #9 ASED (HWP and DT): provide the positions of the Level-0 Interfaces and the displacement and rotations of these interfaces. Due: 9/10/02	9/10/02	MSSL /B. Winter	ASED / HW Peltz and D. Tenhaeff		
#10	Action #10 RAL/MSSL (BW) will evaluate the feasibility of the	7/10/02	ASED / H Faas	RAL/MSSL, B.		



**Meeting:** HP-2-ASED-MN-0182  
**Title:** Mech IF Meeting with SPIRE  
**Date:** 27/09/02

## Action Item List

**Herschel**

	proposed level-0 strap design			Winter		
#11	Action #11 RAL/MSSL (BW) to provide the loads for all bolts. Due: 30/10/02	30/10/02	ASED / H Faas	RAL/MSSL, B. Winter		
#12	Action #12 ASED: Provide tapping depth in the HOB plate. Due: 11/10/02	16/10/02	RAL/MSSL, B. Winter	ASED / A. Mauch		

**SPIRE Mechanical I/F Working Meeting**  
**Astrium, Friedrichshafen**  
**Bldg. 8, Mtg. Room 8105-8107**  
**27 September 2002, starting 08h30**

**Draft Agenda:**

- 1 Introduction
- 2 **Review of SPIRE Interface Drawings, Issue 16 Draft**
  - ⇒ List of comments on Issue 13 (ECR 6b, 6c and 6d covered by HP-ASED-0019/02)
  - ⇒ List of new comments on Issue 16 Draft
- 3 Specific Mechanical I/F Issues:
  - 3.1 Thermal Strap Interface
    - **Level-0 straps I/F:**
      - ⇒ Stiffness, thermal contraction/relative displacement wrt to Optical Bench Plate
      - ⇒ Provision of support for Level-0 thermal straps
      - ⇒ Action on Spire to provide new proposal based on ASED PDR baseline (i.e. cone and Al strap I/F with I/F 57mm above Optical Bench)
      - ⇒ Responsibility for fixation bolts to Spire strap?
      - ⇒ Electrical insulation
    - **Level-1 strap I/F:**
      - ⇒ Stiffness, thermal contraction/relative displacement
      - ⇒ Fixation Options to the SPIRE FPU (only one I/F point on same level as ventline)
    - **Level-3 straps to the Spectrometer and Photometer JFET boxes**
      - ⇒ Electrical insulation
  - 3.2 **SPIRE FPU Alignment**
    - Move new cube (31x31x31mm) in +x direction by 12.5mm (allow alignment of all instruments from one direction, i.e. +z)
    - De-integration of alignment cube to optimise baffle
    - Use of shimming plates to allow last minute corrections during integration of FPU
  - ~~3.3 **Removal of Spire shutter**~~
    - ~~⇒ impact on new instrument aperture, i.e. black and at T=12K~~
  - 3.4 **Fixation of FPU and JFET to HOB**
    - Details of fixation bolts and washers (design to take into account the use of 1mm vespel washers)
    - S-JFET fixation: use of studs and screws. P-JFET: screws only. Why?

- Cone footprint changed from 81 to 75mm. Impact on HOB Plate to be evaluated by ASED
- Responsibility for screws and studs procurements, specs needed, schedule?
- Fixation material should be used at Instrument Test and analysis results are required

### 3.5 Use of dowel pins and shimming plates:

- IID-A requests use of dowel pins, how is the required accuracy guaranteed
- Is use of dowel pins considered to ensure fulfilment of lateral acceleration reqts.?

### 3.6 Bonding strap

- ⇒ Requirement for ASED
- ⇒ responsibility
- ⇒ position and length

## 4 AIV/AIT

### 4.1 General Instrument handling and integration issues

- Lifting device for FPU
- Integration procedure FPU and JFET, including F-harness
- Delivery of fixation bolts (FPU and JFET) for instrument tests required?
- A-frame fixation: access to screw below FPU case to be clarified

### 4.2 JFET handling

### 4.3 Harness

- ⇒ Harness routing: thermal coupling/de-coupling to HOB

### 4.4 TB/TV Tests

- Spire requirements concerning test sequence and duration
- Boundary conditions

### AOB

- ⇒ Instrument shield has been updated: delivery of updated shield in STEP format possible

### Participants:

J. Delderfield	RAL
B. Winter, J. Coker	MSSL
D. Tenhaeff, A. Mauch, O. Stauss, J. Hinger, H. Faas	
A. Hauser, H.W. Peltz, D. Schink (p/t)	ASED

**Comments on SPIRE Configuration Drawings (Issue 16, dated 28/08/2002)****27/09/02**

1. Sheet 1 of 7 and other sheets: Cryostat hole is 288mm. Please update.
2. Sheet 1 of 7: Comment Alternative attachment points: Level-1 strap is connected to ventline, not to Optical Bench. Update.
3. Sheet 1 of 7: Optical Reference Cube changed from 25x25x25mm to 31x31x31mm. Change to be discussed in framework of thermal and straylight impact of alignment cube, if not dismantled.
4. Sheet 1 of 7: Photometer and Spectrometer BDA feedthroughs to be added
5. Sheet 1 of 7: Instrument shield not up-to-date, could be replaced by update
6. Sheet 2 of 7: Lower left IF drawing: FPU top around alignment cube not consistent with other drawings. Please clarify.
7. Sheet 3 of 7: old dimensions of alignment cube left over (25.00mmx25.00mm) but size of cube changed to 31.00x31.00mm. Clarify and update.
8. Sheet 3 of 7: Position and angular accuracy of alignment cube. Note to be clarified. Astrium will specify the allowed offset angle of the reference cube, which has to be agreed by Spire.
9. Sheet 3 of 7: Definition of beam width to be checked with beam in Astrium H-EPLM 3D model (based on Excel data received by email from A. Richards, 17/05/02 and with SPIRE-RAL-NOT-00001242, dated 18/04/02)
10. Sheet 4 of 7: Cone Footprint changed from 81.00 to 75.00mm PSD.
11. Sheet 7 of 7: HIFI Optical Beam clearance: gap between HIFI beam and SPIRE FPU envelope derived by ASSED: 2.59 instead 0.92mm (see fax HP-ASED-0321/02, date 27/05/02). Clarify and update.

Status

Analysis on System PDR Design Baseline,  
Tank PDR next week

Therefore margin needed for Tank Design Evaluation

Component	Direction	Thermal Displacement	Vibration	Pressure of Tank <sup>1)</sup>
Links except PACS	axial	-0.15	+/- 1.1 mm	+0.6mm – 1.8 mm
	lateral	2 mm	+/- 1.7 mm	3 mm
PACS	axial	0.15	+/- 1.1 mm	-1.7 + 5.1 mm
	lateral	1.8 mm	+/- 1.7 mm	-2.8 to + 8 mm

Source: HP-2-ASED-TN-049, Issue 1, Analysis Results

Pressure:

MSC.Patran 2000 r2 25 - Apr - 02 11:20:37

Fringe: Pressure, Static Subcase: Displacements, Translational - (NON-LAYERED) (MAG)

Deform: Pressure, Static Subcase: Displacements, Translational

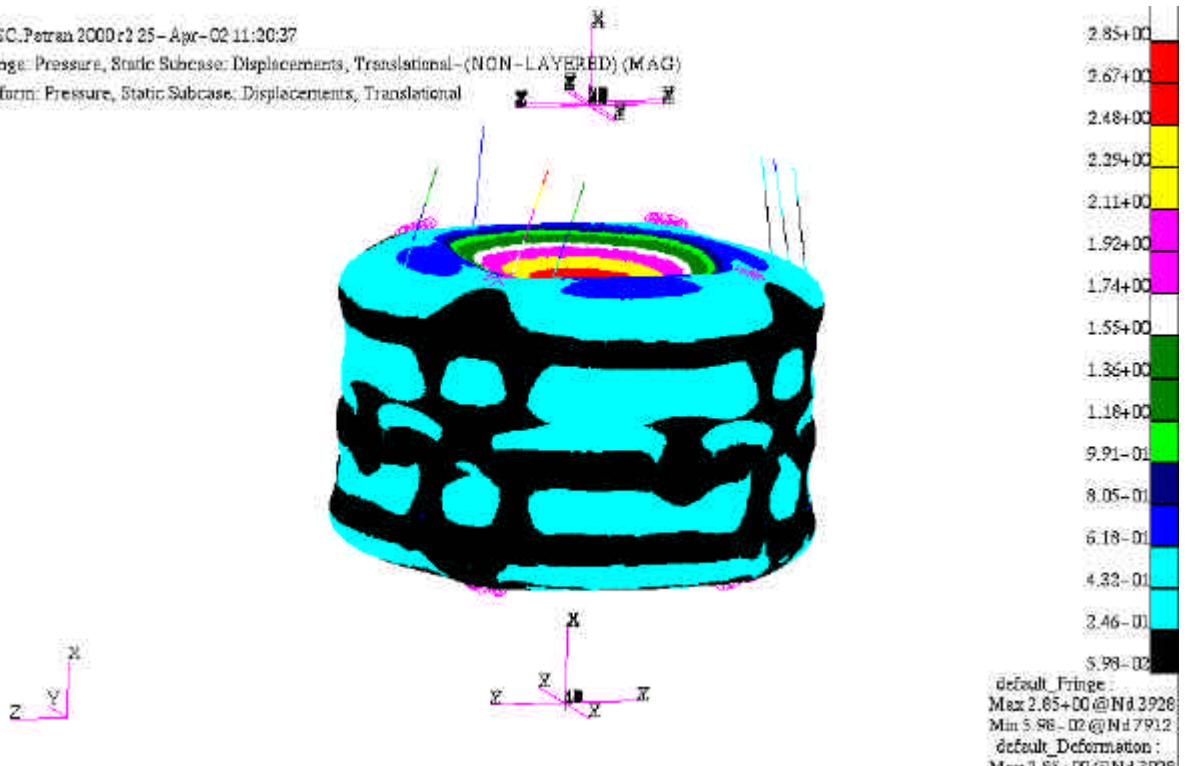

Values under 1 bar (without margin for design development)

ASC.Petra 2000 r3 25- Apr-02 11:23:55

Vector: Pressure, Static Subcase, Displacements, Translational, (NORM-1, AVERAGE)

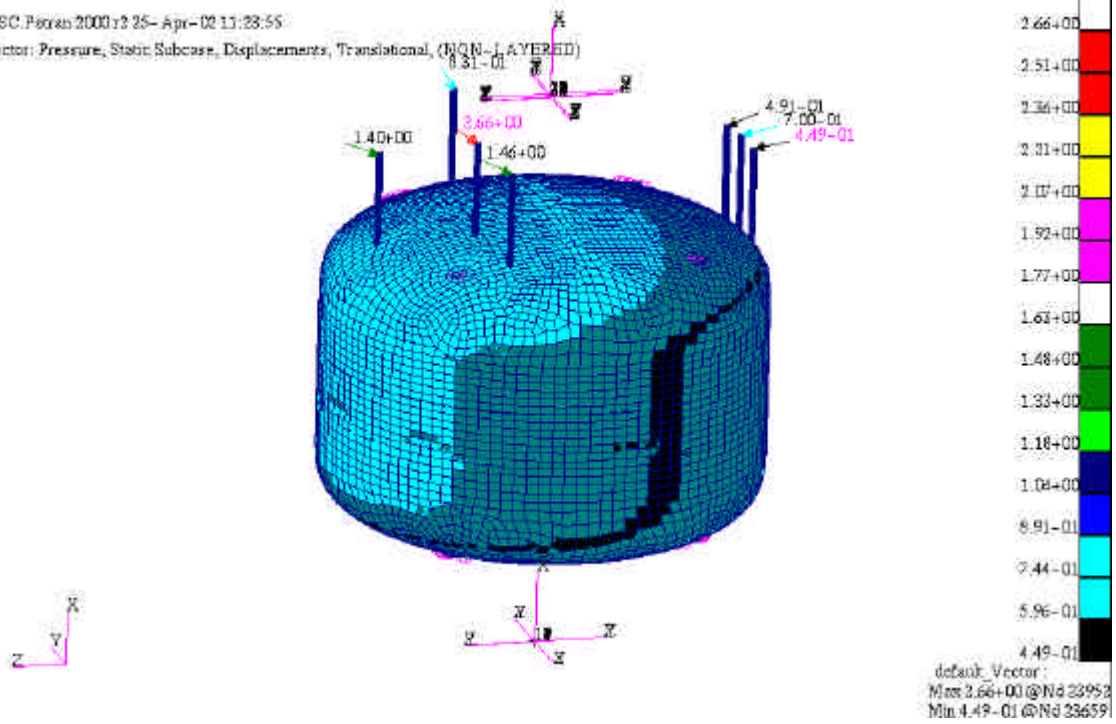

**Pressure:**

Safety valve opening: 1.76 bar

Latest Rupture Disc opening: 3.04 bar

→ 10 mm are an envelope for the level 0 I/F of the instruments

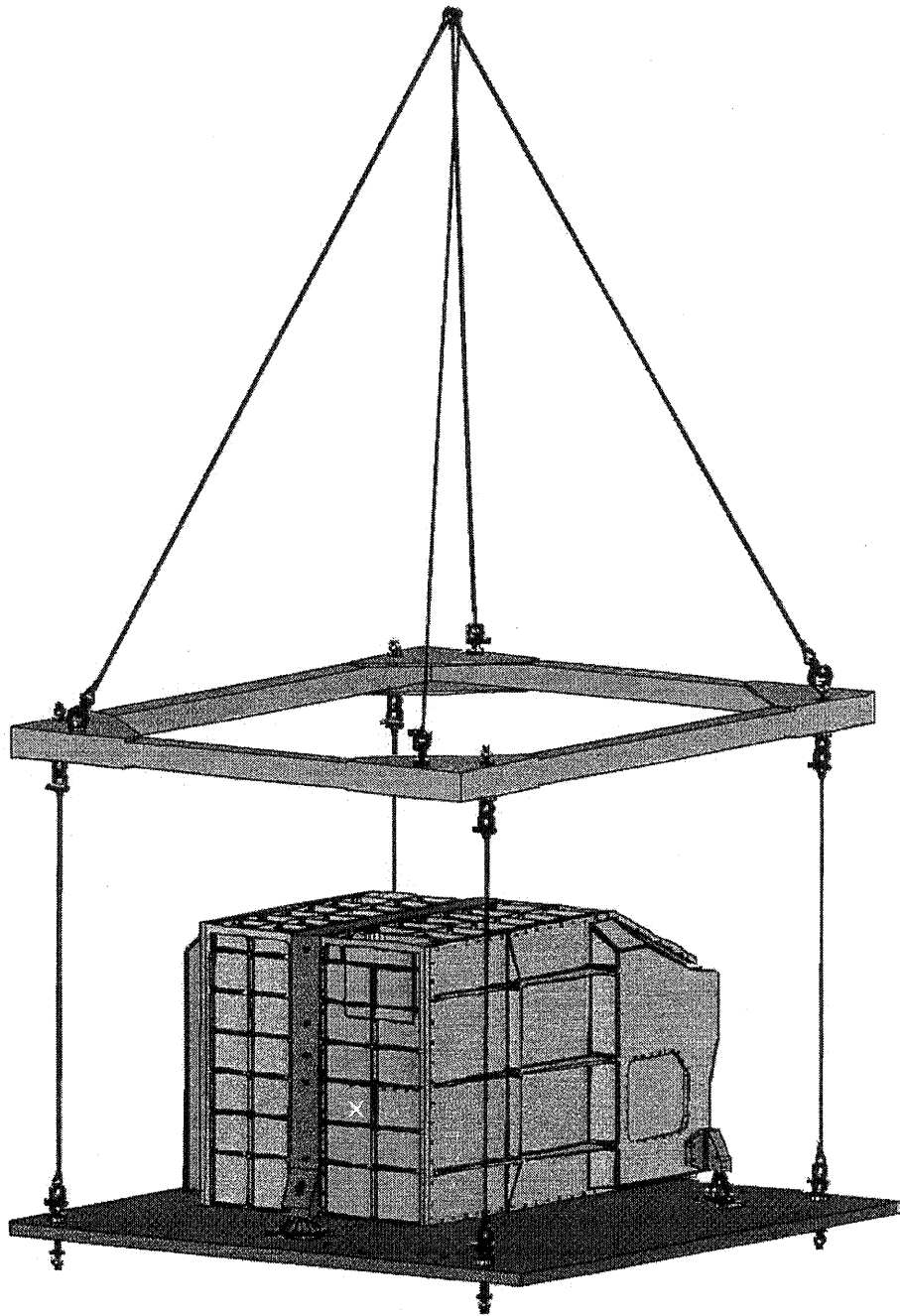

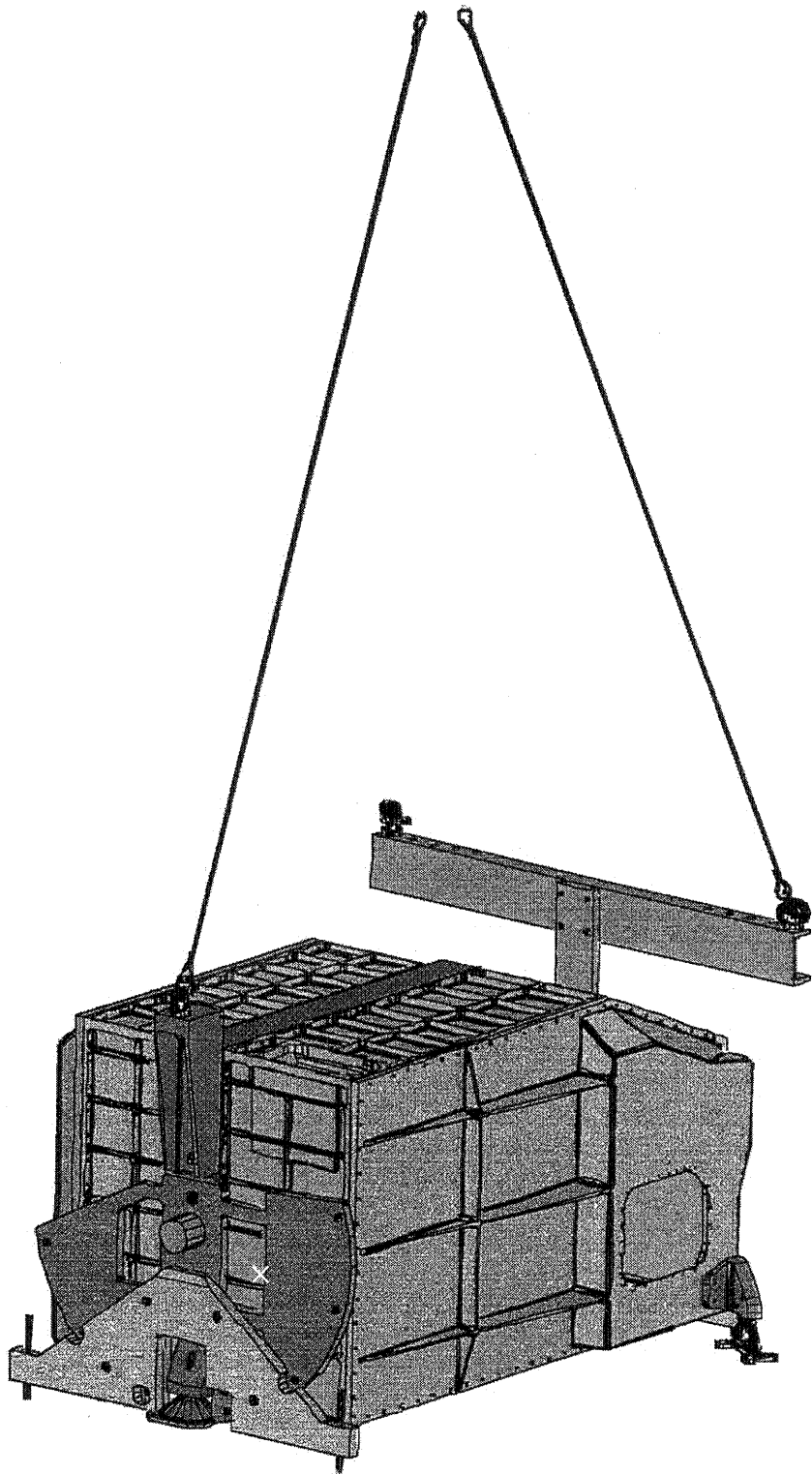



USED ON

DRAWING No.

THIRD ANGLE PROJECTION

DO NOT SCALE

MOVE ALL BURRS & SHARP EDGES

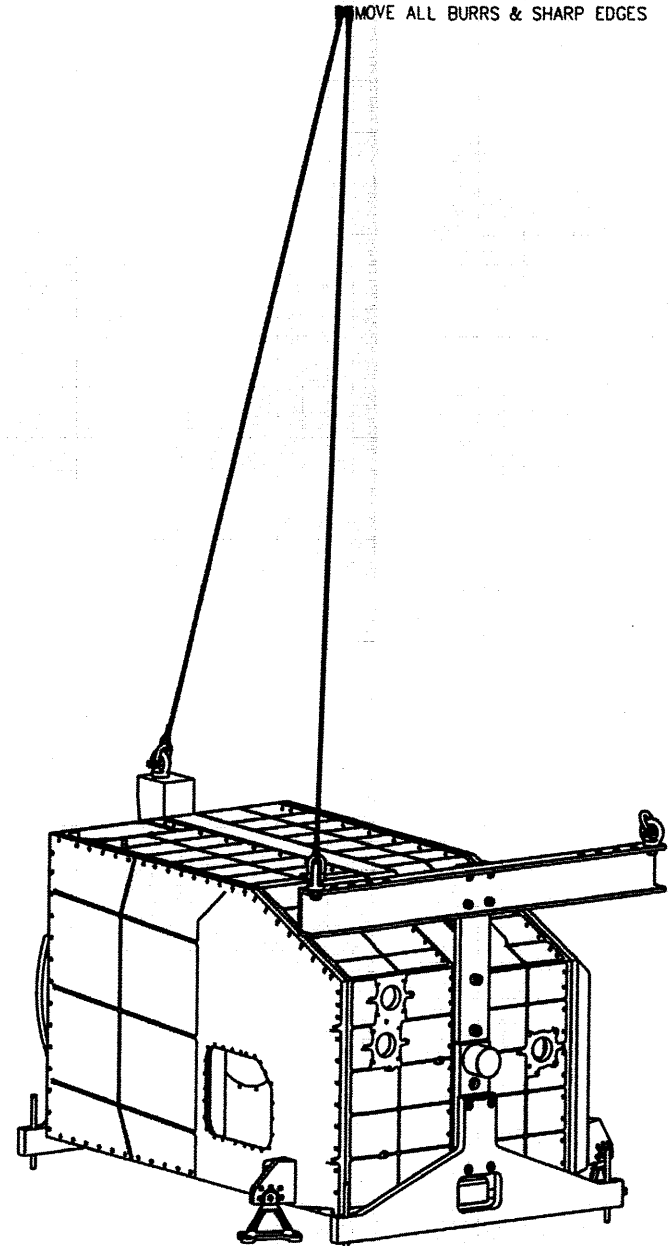
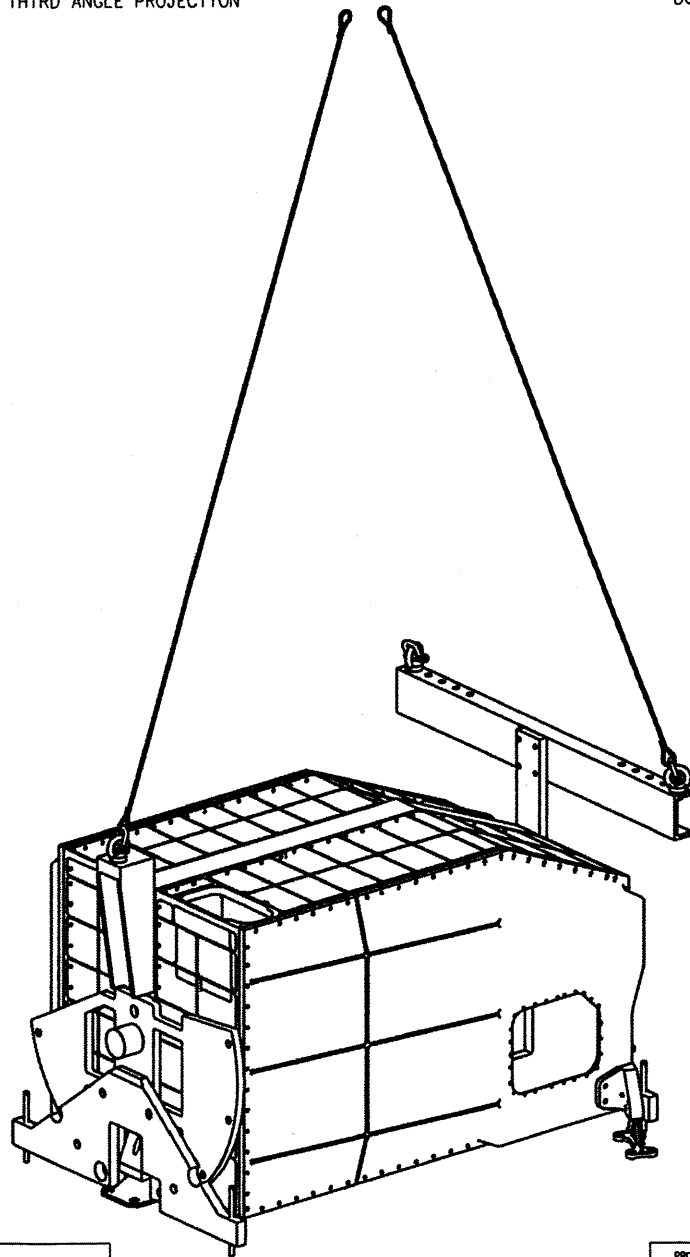

CHECKED				
TRACED				
DRAWN	ISSUE	DATE	AMENDMENT	COMPUTER FILE
PMB	1			

PROTECTIVE FINISH	MATERIAL & SPEC.	TOLERANCES UNLESS OTHERWISE STATED - LINEAR +/- 0.10 ANGULAR +/- 0°15'	DEPARTMENT OF SPACE AND CLIMATE PHYSICS UNIVERSITY COLLEGE LONDON MULLARD SPACE SCIENCE LABORATORY, HOLMBURY ST. MARY, DORKING, SURREY.
ESTD WT.			TITLE
ACTL WT.	DIMENSIONS IN mm	SCALE	DRAWING No A1

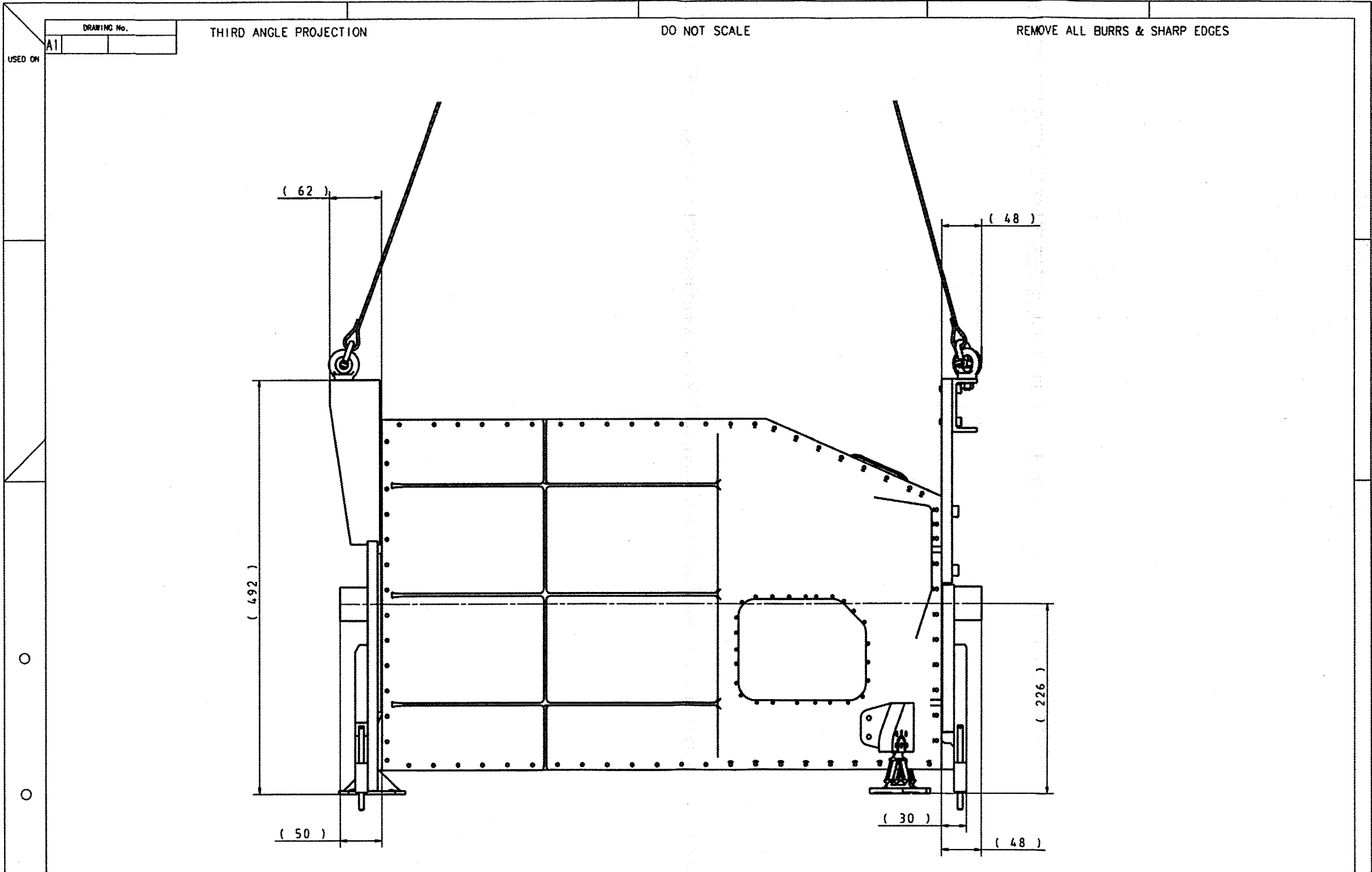

CHECKED			
TRACED			
DRAWN	ISSUE	DATE	AMENDMENT
PMB	1		

COMPUTER FILE

PROTECTIVE FINISH	MATERIAL & SPEC.	TOLERANCES UNLESS OTHERWISE STATED - LINEAR +/- 0.10 ANGULAR +/- 0°15'
ESTD WT.	DIMENSIONS IN mm	SCALE
ACTL WT.		

DEPARTMENT OF SPACE AND CLIMATE PHYSICS UNIVERSITY COLLEGE LONDON MULLARD SPACE SCIENCE LABORATORY, HOLMBURY ST. MARY, DORKING, SURREY.		TITLE	DRAWING No
		A1	

Quantity	Name	Dep./Comp.	Quantity	Name	Dep./Comp.
	Alberti von Mathias Dr.	SM 34	X	Rühe Wolfgang	ED 6
	Barlage Bernhard	ED 11		Runge Axel	OTN/EN 64
X	Bayer Thomas	ED 541		Sachsse Bernt	ED 21
X	Faas Horst	EA 65		Schäffler Johannes	OTN/EN 64
	Fehringer Alexander	SM 33	X	Schink Dietmar	ED 422
	Grasl Andreas	OTN/EN 64	X	Schlosser Christian	OTN/EN 64
	Grasshoff Brigitte	ED 521		Schwabbauer Paul Dr.	OTN/ED 421
	Hartmann Hans Dr.	ED 422		Schweickert Gunn	SM 34
X	Hauser Armin	SM 31	X	Stauss Oliver	SM 33
X	Hinger Jürgen	SM 31		Steininger Eric	ED 422
X	Hohn Rüdiger	ED 541	X	Stritter Rene	ED 11
X	Hölzle Edgar	ED 421		Suttner Klaus	SM 32
	Huber Johann	ED 543	X	Tenhaeff Dieter	SM 34
	Hund Walter	SE 76		Thörmer Klaus-Horst Dr.	OTN/ED 65
	Idler Siegmund	ED 432		Wagner Adalbert	OTN/IP 35
	Ivány von András	ACE 32		Wagner Klaus	SM 31
	Jahn Gerd Dr.	SM 31	X	Wietbrock, Walter	ED 521
	Kalde Clemens	ED 532		Wöhler Hans	SM 34
	Kameter Rudolf	OTN/EN 64		Zipf Ludwig	ACE 32
	Kersting Stefan	OTN/EN 63			
	Knoblauch August	ED 531			
	Koelle Markus	ED 533			
X	Kroeker Jürgen	ED 542	X	Alcatel	ASPI
	Kunz Oliver	SM 31	X	ESA/ESTEC	ESA
	Lamprecht Ernst	OTN/SM 222			
X	Lang Jürgen	SE 76		<b>Instruments:</b>	
	Langfermann Michael	ED 541		MPE (PACS)	MPE
	Mack Paul	OTN/EN 64	X	RAL (SPIRE) + HSSL	RAL
	Maier Hans-Ulrich	ED 11		SRON (HIFI)	SRON
X	Mauch Alfred	SM 34			
X	Moritz Konrad Dr.	ED 65			
	Müller Lutz	OTN/EN 64		<b>Subcontractors:</b>	
	Muhl Eckhard	OTN/EN 64		Air Liquide	AIR
X	Pastorino Michel	ASPI Resid.		Astrium Sub-Subsyst. & Equipment	ASSE
	Peitzker Helmut	ED 65		Austrian Aerospace	AAE
X	Peltz Heinz-Willi	SM 33		APCO Technologies S. A.	APCO
	Peters, Gerhard	ED 531		Astrium GmbH Space Infrastr.	ASIP
	Pietroboni Karin	ED 65		BOC Edwards	BOCE
	Puttlitz Joachim	OTN/EN 64		EADS CASA ESPACIO	CASA
	Raupp Helmut	SM 33		Eurocopter	ECDE
X	Rebholz Reinhold	ED 541		HTS AG Zürich	HTSZ
	Reuß Friedhelm	ED 62		Linde	LIND