





SPIRE INSTRUMENT

**DRCU / DPU
INTERFACE CONTROL DOCUMENT
SPIRE-SAP-PRJ-001364**

Contributors:
F. PINSARD-DCU Engineer
D. FERRAND-MCU Engineer
M. MUR-SCU Engineer

	Name and Function	Date	Signature
Prepared by:	C.CARA - DRCU Responsible	19/07/2006	
Checked	J. FONTIGNIE	21/07/06	
Approved by:	F.PINSARD D. FERRAND M. MUR		
Approved by:	PA Responsible <i>J. FONTIGNIE</i>	<i>21/07/06</i>	
Approved by:	JL. AUGUERES - Project Manager	<i>21/07/06</i>	

SPIRE INSTRUMENT

DRCU / DPU

INTERFACE CONTROL DOCUMENT

SPIRE-SAP-PRJ-001364

Contributors: **F. PINSARD-DCU Engineer**
 D. FERRAND-MCU Engineer
 M. MUR-SCU Engineer

	Name and Function	Date	Signature
Prepared by:	C.CARA - DRCU Responsible	19/07/2006	
Checked	J. FONTIGNIE		
Approved by:	F.PINSARD D. FERRAND M. MUR		
Approved by:	PA Responsible		
Approved by:	JL. AUGUERES - Project Manager		

Document change record

Issue/Revision	Date	Modified pages
0.1	18/05/2000	All: document creation - Draft
0.2	21/06/2000	§1.1 : reference documents table inserted §1.3 : Figure corrected §1.4.1 : Table 1.4.1-a updated §1.5.1 : parity suppressed §1.5.2 : parity suppressed §2.5.1 : Figures updated §2.5.2 : Figures/Table added §2.5.3 : Figure added
0.3	17/11/2000	Many: introduction of WE Summit decisions
0.4	21/06/2000	
0.5		§2.1.4.1 Command/parameter fields updated - CID11 = R/W §2.2 generic command list added S/S command list updated/added §2.3.5.2 FrameID tables added
0.6	1/03/2002	Power Profile added Power budget updated (according to RD3) S/S data format description updated: MCU trace and test added Block format updated (new position for FrameTime) Updated list of connectors Secondary power interface for DCU/MCU/SCU added/updated Thermal & mechanical interfaces with S/C added
0.7	26/06/2002	INITIAL DOCUMENT SPLITTED §1.3 & 1.4 Updated lists §2.1.2 Updated figure acronyms §2.1.4.1 Note removed & able 2.1-c corrected according to KJK/JD comments §2.1.4.2 NACK : DRCU S/S is off removed §2.1.5 Updated delay table / added reference to "SetDPUPollingTime" §2.2.1 DRCU generic command list corrected / parameter description added §2.2.8 DCU specific command / parameter list corrected / command codes corrected §2.2.9 MCU specific command chapter corrected. Full command/parameter description moved to AD2 §2.2.13 SCU specific command list corrected / command codes added §2.3.2 Updated figure acronyms §2.3.5.2 FrameID added for DCU Test Pattern formats §2.3.5.3.1 Format sizes corrected §2.3.5.3.4 Format sizes corrected §2.3.5.3.5 Format sizes corrected §2.3.6 Test Pattern : initialisation vector description added §2.2.6.4/§2.2.6.6 LIA channel to bolometer id table added
0.8		§2.2.5.2/§2.2.5.3: table corrected according to DDR comment n°6 & 7 §2.2.6.x.x many corrections according to DDR comments n°8/9/10 §2.1.5.2 Timing update / diagram added §2.1.5.3 Rate corrected §2.2.5 DCU command - Many corrections / updates - Command descriptions improved §2.2.6.2/§2.2.6.4 Tables partially filled

		<p>§2.2.7 parameter description - Corrected/completed §2.2.9 Updated according to AD2 §2.2.13 Updated command codes - Command added §2.3.5.2 List of frame ID completed (DCU test pattern formats added) §2.3.5.3.2/3 Pixel order re-arranged §2.3.5.3.4 Table updated - definition clarified §2.3.5.3.5 frame definition updated according to AD2 2.3.6 Diagram added §2.3.7 timing finalized / diagram added</p>
1.0		<p>§2.2.8.3.1 steps 2 and 5: SetFrameMode replaced with SetDataMode (document correction) §2.2.8.3.2 Steps numbering corrected (cosmetic) §2.2.8.6.2 Steps numbering corrected (cosmetic) §2.3.5.3.1 ADC data word definition added (new information) §2.2.1 added comment for not implemented commands in DCU §2.2.2 Unit column corrected §2.2.7.4 Table corrected LIA_Px & LIA_Sx instead of LIA_Bx §2.2.7.5 new chapter PWR_STATUS word definition</p>
1.1		<p>§1.3/§1.4 MCU command list moved from AD to RD §2.1.4.2 : added comments after Table 2.1-d §2.1.4.2 : Table 2.1-e corrected §2.2.1 : note added §2.2.3 : Parameters description table filled §2.2.5.2 : CID column added – Command name list corrected §2.2.5.3 – 2.2.5.4 – 2.2.5.5 : CID column added §2.2.6.5.1 : Parameters description corrected §2.2.7 : Default parameters indication §2.2.7.4 : Parameter order corrected §2.2.7.5 : Power Status word definition added §2.2.9 : CID column added to tables §2.2.9.6 : jiggle commands tables added §2.2.10 : MCU command description pasted from RD6 §2.2.11 : Typical scenarios pasted from RD6 §2.2.12 : CID column added to tables §2.2.14 : Parameters description filled – Default values shown §2.2.15 : Typical scenarios – Chapter header §2.3.5.3.5 : Frame sizes corrected §2.3.5.3.7 : Param#6 added §2.3.5.3.9 : Frame content description §2.3.5.3.11 : Parameter ordering corrected §2.3.6 : Test pattern description updated §2.3.7 : Interface timing added</p>
1.2	18/10/04	<p>Update from issue 4.0 of MCU/DPU Command List: §2.2.9.3 : SetBootRam code is 0x24 instead of 0x27 §2.2.9.4.1 : Set/GetSMotorMode cancelled, Set/GetSFeedFwdDiffGain cancelled, Set/GetLVDTLUT cancelled, commands 057 to 05C moved from Write only to Write/Read commands §2.2.9.4.2 : GetMeanSpeed to GetSBEMF codes corrected</p>
1.3	07/02/06	<p>Update from issue 5.0 of MCU/DPU Command List §2.2.14.1.6 & §2.2.14.1.7: added note to take into account HR-SP-RAL-NCR-063v2 §2.2.6.1.13 & 2.2.6.3.10: note added to take into account NCR HR-SP-PAL-NCR-152 §2.2.5.2 & 2.2.5.3: table are corrected – GetLIAxxOffset is not implemented as described in §2.2.6.1.13 & §2.2.6.3.10</p>

Distribution list

Jean-Louis AUGUÈRES	CEA	
Frederic PINSARD	CEA	
Jean FONTIGNIE	CEA	
Michel MUR	CEA	
Riccardo CERULLI	IFSI	
Renato ORFEI	IFSI	
Jerry LILIENTHAL	JPL	
Didier FERRAND	LAM	
Dominique POULIQUEN	LAM	
Ken KING	RAL	
Eric SAWYER	RAL	
Bruce SWINYARD	RAL	
Goran OLOFSSON	SO	
Hans-Gustav FLOREN	SO	

List of Acronyms

ADC	Analog to Digital Converter
AMUX	Analog Multiplexer
BSM	Beam Steering Mirror
DAC	Digital to Analog Converter
DCE	Detector Control Electronics
DCU	Detector Control Unit
DMUX	Digital Multiplexer
DPU	Data Processing Unit
DRCU	Detector Readout & Control Unit
FPU	Focal Plane Unit
FTS	Fourier Transform Spectrometer
JFET	Junction Field Effect Transistor
LIA	Lock-in amplifier
LPF	Low Pass Filter
MCE	Mechanisms Control Electronics
MCU	Mechanisms Control Unit
NA	Not Applicable
NC	Not connected
OEP	Optical Encoder Preamplifier
PDU	Power Distribution Unit
PSU	Power Supply Unit
S/S	Sub-System
S/W	Software
SCE	Sub-system Control Electronics
SCU	Sub-system Control Unit
SMEC	Spectrometer Mechanism Control
SMPS	Switching Mode Power Supply
SNR	Signal over Noise Ratio
TBC	To Be Confirmed
TBD	To Be Defined
TBW	To Be Written
WIH	Warm Interconnect Harnesses

Table of Contents

1. INTRODUCTION.....	9
1.1. PURPOSE.....	9
1.2. SCOPE.....	9
1.3. REFERENCE DOCUMENTS.....	9
1.4. APPLICABLE DOCUMENTS.....	9
2. ELECTRICAL INTERFACES WITH THE DPU	10
2.1. COMMAND INTERFACE	10
2.1.1. <i>General Information</i>	10
2.1.2. <i>Interface Overall Diagrams</i>	11
2.1.3. <i>Interface Circuit</i>	11
2.1.4. <i>Protocol definition</i>	13
2.1.4.1. Command Word.....	13
2.1.4.2. Response Word	14
2.1.5. <i>Interface Timing</i>	15
2.1.5.1. Low-level Timing	15
2.1.5.2. Command timing	16
2.1.5.3. Command Rate.....	16
2.2. COMMAND LISTS.....	18
2.2.1. <i>DRCU generic command list summary</i>	18
2.2.1.1. Command and parameter mapping.....	18
2.2.1.2. Write only commands.....	18
2.2.1.3. Read only commands *	18
2.2.1.4. Read/Write Commands *	18
2.2.2. <i>DRCU command description</i>	19
2.2.2.1. CmdIFStat *	19
2.2.2.2. CmdIFCtrl *	19
2.2.2.3. SubSDelay *	19
2.2.2.4. TstampRst.....	20
2.2.3. <i>DRCU generic commands parameter description</i>	20
2.2.4. <i>DRCU typical commanding scenarios</i>	21
2.2.5. <i>DCU specific command list summary</i>	22
2.2.5.1. Command and parameter mapping.....	22
2.2.5.2. Photometer write/read commands	22
2.2.5.3. Spectrometer write/read commands	23
2.2.5.4. Photometer / spectrometer common write/read commands	23
2.2.5.5. Read only commands	24
2.2.6. <i>DCU command description</i>	24
2.2.6.1. Photometer	24
2.2.6.2. LIA_P channel/Bolometer number cross table	30
2.2.6.3. Spectrometer	31
2.2.6.4. LIA_S channel/Bolometer number cross table	34
2.2.6.5. Photometer & Spectrometer common commands	35
2.2.7. <i>DCU parameters description</i>	37
2.2.7.1. Photometer	37
2.2.7.2. Spectrometer	39
2.2.7.3. Photometer & Spectrometer.....	40
2.2.7.4. DCU housekeeping identifier list	41
2.2.7.5. PWR_STATUS word definition.....	41
2.2.7.6. DCU boards temperature conversion	42
2.2.7.7. DCU supply voltages conversion	42
2.2.7.8. T/C channel conversion.....	42
2.2.8. <i>DCU typical commanding scenarios</i>	43
2.2.8.1. DCU Configuration	43

2.2.8.2.	Photometer Configuration	45
2.2.8.3.	Photometer offset setting	45
2.2.8.4.	Photometer acquisition	46
2.2.8.5.	Spectrometer Configuration	46
2.2.8.6.	Spectrometer offset setting	46
2.2.8.7.	Spectrometer acquisition	47
2.2.9.	<i>MCU specific command list summary</i>	48
2.2.9.1.	Forewords	48
2.2.9.2.	Command and parameter mapping	48
2.2.9.3.	General commands	48
2.2.9.4.	SMEC commands	49
2.2.9.5.	Chop commands	52
2.2.9.6.	Jiggle commands	54
2.2.9.7.	Telemetry and trace configuration commands	56
2.2.9.8.	HK and miscellaneous commands	56
2.2.10.	<i>MCU command/parameter description</i>	57
2.2.10.1.	General commands	57
2.2.10.2.	<u>SMEC commands</u>	58
2.2.10.3.	<u>CHOP commands</u>	62
2.2.10.4.	<u>JIGGLE commands</u>	64
2.2.10.5.	Telemetry commands	66
2.2.10.6.	HK and miscellaneous commands	68
2.2.11.	<i>Main transfer functions</i>	68
2.2.11.1.	SMEC motor current	68
2.2.11.2.	Encoder signal	69
2.2.11.3.	SMEC LVDT position	69
2.2.11.4.	BSM motor currents	69
2.2.12.	<i>Commanding scenarios</i>	71
2.2.12.1.	Scenario sequence	71
2.2.12.2.	Power on and MCU first boot scenario	72
2.2.12.3.	BSM set up scenario for closed loop	73
2.2.12.4.	BSM science operation: independent control (CHOPPER)	73
2.2.12.5.	BSM Science operation : synchronous control of both axis	73
2.2.12.6.	SMEC latch off scenario	74
2.2.12.7.	SMEC set up scenario	74
2.2.12.8.	Encoder init and closed loop operation	75
2.2.12.9.	SMEC science operation: performing a scan	75
2.2.12.10.	Performing a step and integrate pattern	76
2.2.12.11.	Power off of the SMEC axis control	76
2.2.12.12.	Telemetry typical scenario	76
2.2.13.	<i>SCU specific command list summary</i>	77
2.2.13.1.	Command and parameter mapping	77
2.2.13.2.	Write/read commands	77
2.2.13.3.	Read only commands	78
2.2.14.	<i>SCU command description</i>	79
2.2.14.1.	Read/Write commands	79
2.2.14.2.	Read only commands	83
2.2.15.	<i>SCU parameters description</i>	89
2.2.16.	<i>SCU typical commanding scenarios</i>	93
2.3.	DATA INTERFACE	94
2.3.1.	<i>General Information</i>	94
2.3.2.	<i>Overall Interface Diagram</i>	94
2.3.3.	<i>Interface Circuit</i>	94
2.3.4.	<i>Word definition</i>	95
2.3.5.	<i>General Frame Definition</i>	96
2.3.5.1.	Length	96
2.3.5.2.	Frame ID	96
2.3.5.3.	Data structure	97
2.3.5.4.	Frame time	106
2.3.5.5.	Check word	106

2.3.6.	<i>Test pattern</i>	106
2.3.7.	<i>Interface Timing</i>	107

1. Introduction

1.1. Purpose

The purpose of this document is to provide a description of all the DRCU units' electrical interfaces to the DPU. Along with the "DRCU ICD" and the "MCU/DPU Command List ICD" this document shall allow a complete overview of the DRCU units in terms of interfaces.

1.2. Scope

The scope of this document includes all the DRCU units external interfaces low-level description including electrical and low level protocol and connector pin-out.

1.3. Reference Documents

RD1	Note IFSI : <i>DPU/DRCU Interfaces</i>	SP-RCI-18.5.00
RD2	Efficient Shift Registers, and Long Pseudo-Random Sequence Generators	XILINX XAPP 052
RD4	A Generic DPU Interface for SPIRE DRCU Subsystems	CEA internal note
RD5	DPU Interface Control Document	SPIRE-IFS-PRJ-00650 - Issue: 1.3 13/02/2003
RD6	MCU/DPU Command List ICD and User Manual	LAM/ELE/SPI/011011 issue 4.0

1.4. Applicable Documents

AD1	Herschel/Planck IID part A	SCI-PT-IIDA-04624

2. Electrical interfaces with the DPU

The DRCU has two kinds of interface with the DPU: one is devoted to low level command transmission (to the DRCU) for H/W configuration and housekeeping/status parameters reporting while the second is in turn devoted to data transfer from the DRCU to the DPU for further packing activities.

While the low-level command interface is slow (312.5 kps) bi-directional with word-based protocol the data transfer interface is fast (between 1.25 Mbps and 2.5 Mbps depending on the S/S – see §2.3.7) unidirectional with frame-based protocol.

2.1. Command interface

2.1.1. General Information

The command interface goal is manifold:

- Passing of commands from the DPU to the DRCU subsystems.
- Setting of DRCU Subsystems parameters.
- DRCU Subsystems synchronisation.

Physically it consists in 3 sets of bi-directional point-to-point links between the DPU and the DRCU (one link per DRCU subsystem except PSU: DCU MCU & SCU). The protocol is master-slave based, the DPU being the master.

It allows operating independently the 3 DRCU sub-units.

All commands being sent simultaneously to the 3 DRCU subsystems each subsystem recognising its own commands by means of an address inserted into the command word. In addition a broadcast address allows sending the same (broadcast) command simultaneously to the 3 DRCU sub-units.

The command format is fixed and consists in a 32-bit word with 3 fields:

- a DRCU sub-unit address field,
- a command identifier field,
- a parameter field.

DRCU subsystems, if addressed individually (with SYN0=0 see table 2.1-a) reply with a response word with the following format:

- a field for reporting interface error (in place of the sub-unit address),
- a field echoing the command identifier,
- a data field which contains, either the echo of the command parameter, or a data requested by the command (housekeeping parameter).

In the case of broadcast command, no acknowledgement is sent back by the DRCU subsystems. If the DPU requires acknowledgement it has to be carried out by sending successive acknowledgement request (specific command) to the DRCU sub-units.

2.1.2. Interface Overall Diagrams

The Command Interface diagram is given in figure 2.1-a.: main and redundant interfaces are shown.

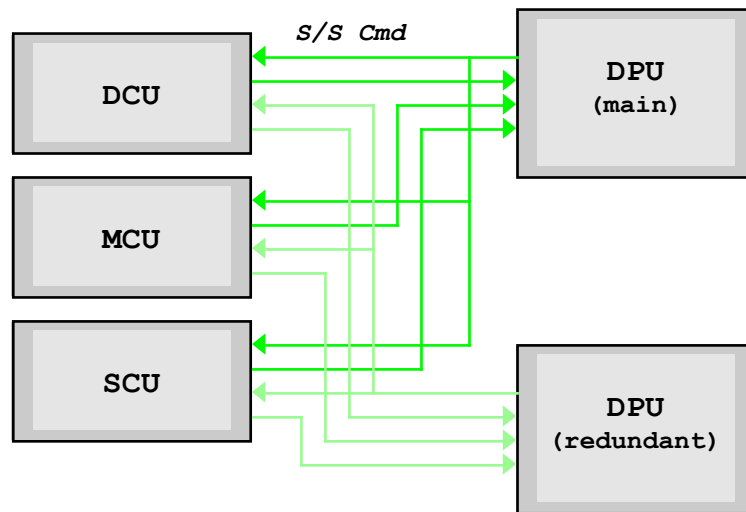

Figure 2.1-a

2.1.3. Interface Circuit

Each interface is defined by the following signals:

- a command (CMD) line - from DPU to DCU, MCU, SCU sub-units
- a response (RES) line - from each sub-unit to DPU
- a clock (CLK) line for bit synchronisation and S/S format time clock- from the DPU to DCU, MCU, SCU sub-units.

Each sub-unit implements a complete set of the above interface signals: that is the DPU implements 3 electrically independent “Command Interfaces” each having 2 transmitters + 1 receiver. However all those signals are interconnected type by type inside the DPU. In particular the 3 RES signals are mixed according to the sub-unit address previously sent.

The interface uses the balanced lines RS422 electrical standard based on 26C31 and 26C32 transmitter and receiver types.

Complete interface functional and electrical diagrams are given figures 2.1-b and 2.1-c.

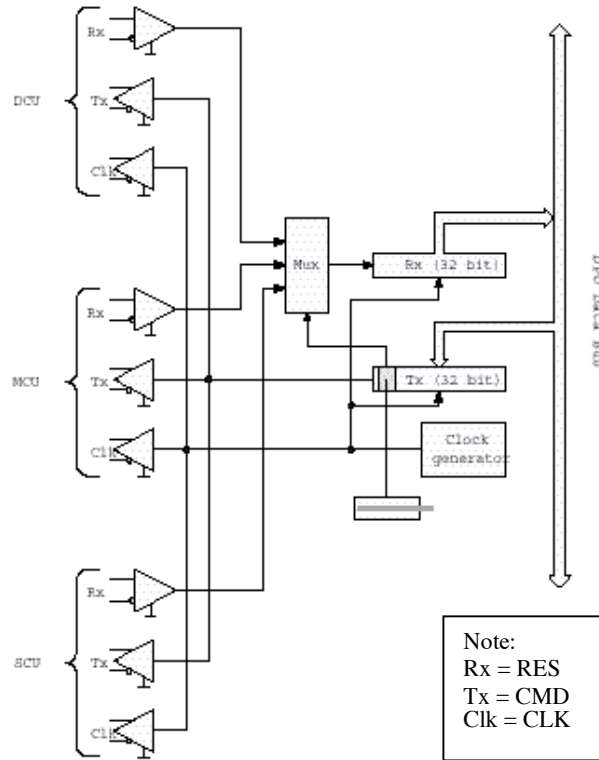

Figure 2.1-b - DPU Low Speed Interface Functional Diagram

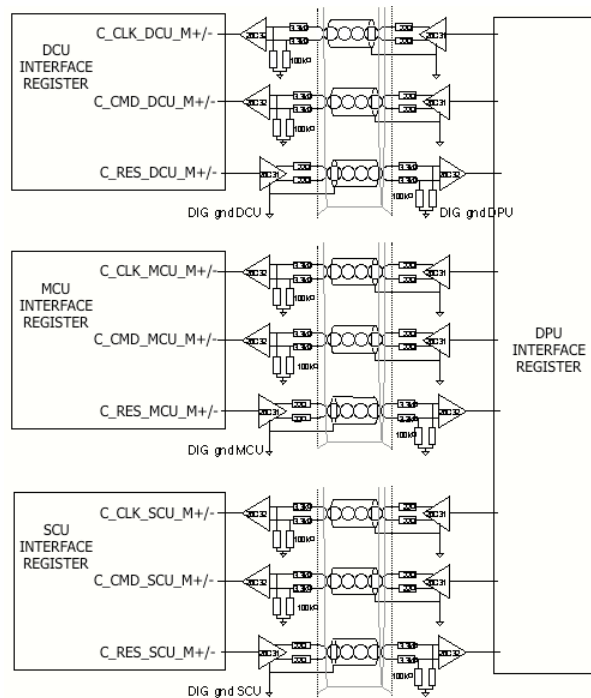

Figure 2.1-c – DPU/DRCU Low Speed Interface Electrical configuration

2.1.4. Protocol definition

2.1.4.1. Command Word

At any time after completion of a previous command/response exchange the DPU can send command words to the DRCU subsystems on the CMD line.

The 32-bit command word is divided into 5 fields as defined bellow:

- a 2-bit sync pattern: see table 2.1-a for details,
- a 2-bit sub-unit address: see table 2.1-b for details,
- a 12-bit command identifier: see table 2.1-c for details,
- a 16-bit parameter when applicable*.

*: Filled with zero if the command does not require any parameter.

These 4 fields are concatenated as follow to form the 32-bits word:

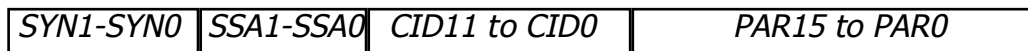

Figure 2.1-d - Command Word Field Structure

SYN1 - SYN0 : sync. pattern
 SSA1 - SSA0 : subsystem address
 CID11 to CID0 : command identifier
 PAR15 to PAR0 : command parameter*
 *: filled with zero if no used

Note : • MSB is transmitted first
 • SYN1 = MSB
 • PAR0 = LSB

SYN1	SYN0	Response
1	0	Yes
1	1	No

Table 2.1-a - Sync Pattern definition

SSA1	SSA0	Subsystem Name
0	0	DCU
0	1	MCU
1	0	SCU
1	1	Broadcast Command

Table 2.1-b - Subsystem address allocation

Bit 11 of the Command Identifier determines the type of the command between Read (or Get) and Write (or Set). The following table explicits the R/W bit definition:

CID11	CID10--CID0	Command Type
1	X	Read
0	X	Write

Table 2.1-c - Command Identifier Structure

Note: the subsystems do not include any command buffering. If a subsystem is unable for any reason to execute a command it will reply with a negative acknowledge and the last command is definitively lost.

2.1.4.2. Response Word

The response line (RES) enables command verification and DRCU sub-system housekeeping parameters reading by the DPU.

When a “*SetParameter*” command (with SYN0=0) is received the subsystem responds to the DPU by transferring a command acknowledge word (positive or negative) on the response line. The positive acknowledgement is normally required for further command transfer after specific critical commands.

When a “*GetParameter*” command is received (with SYN0=0) the subsystem responds to the DPU by transferring the requested housekeeping parameter. (SPIRE housekeeping parameter polling is running typically at 1Hz).

The sub-system shall respond (leading bit of the response word) within a maximum delay of N clock periods as shown table 2.1-e. The DPU S/W shall include a time-out in order to recover from a lack of response and then report such anomaly.

The 32-bit command response is divided into 4 fields, which are:

- a 2-bit sync pattern (SYN0 & SYN1),
- a 2-bit acknowledge code word (ACK0 & ACK1),
- a 12-bit command or parameter address echo (CID11 to CID0),
- a 16-bit parameter (PAR15 to PAR0) echo or requested housekeeping.

- Note :
- MSB is transmitted first
 - SYN1 = MSB
 - PAR0 = LSB

These 4 fields are concatenated as follow to form the 32-bits word:

<i>SYN1-SYN0</i>	<i>ACK1-ACK0</i>	<i>CID11 to CID0</i>	<i>PAR15 to PAR0</i>
------------------	------------------	----------------------	----------------------

Along with the “synchro. Pattern”, Command Id field and the Parameter field an acknowledge word is in place of the sub-system address field of the received command. While the ACK field contents nominally a null character (00 binary) provision for “negative” acknowledge has been introduced to enable sub-system reporting in case of anomaly.

A “negative” acknowledge may result from the following reasons:

- a transmission error occurred: receiver does not recognise command identifier,
- a command is not allowed in a specific subsystem status : interface returns ACK code = CID forbidden,
- the S/S H/W does not respond to the I/F H/W within a given delay: return ACK code = S/S time-out.

ACK	Command Status
00	OK
01	CID unknown
10	CID forbidden
11	S/S Time-out

Table 2.1-d

CID unknown means this command code is not known to the subunit (this code is returned each time a subsystem receives a command with a CID which don't corresponds to a command described later in this document).

CID forbidden means that this command cannot be carried out in a particular mode (MCU has no forbidden commands implemented while DCU rejects all commands for sine bias parameter modification when data frame emission is activated)

2.1.5. Interface Timing

2.1.5.1. Low-level Timing

The CMD signal transmitted by the DPU is modified on the falling edge of the CLK signal. Since CLK to CMD delay can be negative (see table 2.1-e) this signal shall be sampled by the DRCU subsystem on a rising edge of the CLK signal. To validate the command the subsystem shall identify the word sync pattern (“10” or “11”) and then check the subsystem address. If one of these conditions is not fulfilled the subsystem input logic shall stay in the “wait for command” status.

When responding to a command a subsystem shall transmit the RES synchronously with the DPU CLK signal. The RES signal shall be modified on the falling edge of the CLK signal and being sampled by the DPU on the rising edge of the CLK signal. Similarly to a DRCU subsystem the DPU shall identify the sync pattern (“10” or “11”) to properly synchronize the input register to the RES signal.

2.1.5.2. Command timing

The figure 2.1-d specifies the command interface timing. Delays are given for both mode of the protocol:

- command without response
- command with response

The maximum “command to response” delay depends on the considered subsystem. A time-out is implemented in the DPU interface in order to avoid logic lock in the case a subsystem is not able to respond within a given maximum time. The DPU interface time-out value being identical for the 3 subsystems it is fixed by the slowest one.

The following value are given from sub-system designs:

S/S	t ₅ (nominal)	t ₅ (S/S time-out *)
DCU	≤ 150 μs	NA
MCU	≤ 50 μs	≤ 812.8 μs
SCU	≤ 100 μs	≤ 812.8 μs

Table 2.1-e

* an internal time-out is implementation in both MCU and SCU between the DRCU/DPU interface logic and the S/S specific logic.

Then the maximum delay the DPU S/W has to take into account is given by:

$$TO \text{ (DPU S/W time-out)} \geq t_{5\max} + t_7 + t_{\text{CMD}} + t_{\text{RES}} = 1034 \mu\text{s}$$

2.1.5.3. Command Rate

The NRZ data rate being fixed at 312,500 bit per second the absolute maximum command rate can be computed. The command rate including both command word transmission and command response word transmission is (when no S/S time-out occurs):

$$\text{Max. Command rate} = \frac{1}{(3.2\mu\text{s} \cdot 33) \cdot 2 + t_{5\max} + t_7} \leq 2630 \text{ commands per second.}$$

This value gives the maximum rate supported by the protocol. Real rates will have to take into account the DPU software performance.

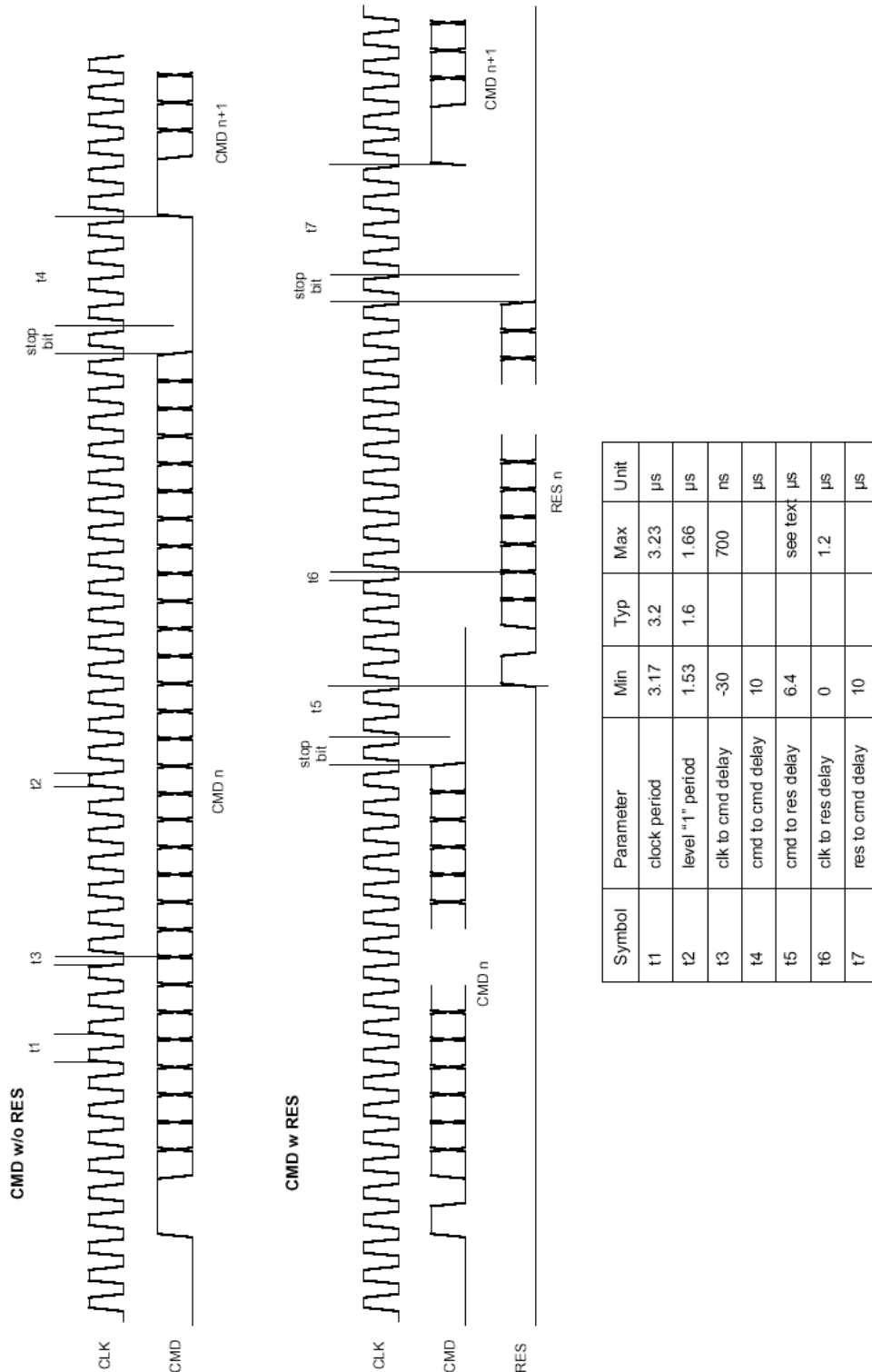

Figure 2.1-d Command interface - Detailed timing

2.2. Command lists

2.2.1. DRCU generic command list summary

2.2.1.1. Command and parameter mapping

The following table shows respectively the bit mapping for CID and PAR field of a low-level command for the DRCU.

CID11	CID10 to CID0	PAR15 to PAR0
R/ \bar{W}	Command Code	Parameter(s)

Note: These list refer to commands possibly common to the 3 DRCU S/S. The execution of these commands is supported by the DRCU to DPU (CmdIF) interface H/W only.

2.2.1.2. Write only commands

Command Name	Argument(s)	Ranges List	Command verification	Execution Delay
SetTStampRst	NA	NA	Ack. code	

2.2.1.3. Read only commands *

Command Name	Argument(s)	Ranges List	Command verification	Execution Delay
GetCmdIfStat	CmdIFStat	NA	NA	
GetSubSDelay	SubSDelay	0 to 511	NA	

2.2.1.4. Read/Write Commands *

Command Name	Argument(s)	Ranges List	Command verification	Execution Delay
Set/GetCmdIfCtrl	CmdIFCtrl	NA	Get... cmd	

* supported by MCU and SCU only. Sending these command to the DCU will generate a CID unknown acknowledge code.

2.2.2. DRCU command description

2.2.2.1. CmdIFStat *

Command	Unit	Code	Description
GetCmdIFStat	MCU SCU	800	Get the S/S interface status. This command is implemented for diagnostic purpose when i.e. previous command returned a non OK acknowledge.
Returned Parameter(s)	Location	Length	
CmdIFStat	0	6	Bit 5-4: LastCmdStatus Bit 3: SubSystemTimeout Bit 2: ForbiddenRead Bit 1: ForbiddenBroadcast Bit 0: CommandOverlapped

2.2.2.2. CmdIFCtrl *

Command	Unit	Code	Description
SetCmdIfCtrl	MCU SCU	001	Set the S/S command IF control word. This command has to be sent after a power-up (to MCU and SCU). Use to recover from a MCU S/W failure is an other function of this command
Parameters	Location	Length	
CmdIfCtrl	0	3	Bit 2: StatusRst Bit 1 : SubSystemRst Bit 0: DataIFReset

Command	Unit	Code	Description
GetCmdIfCtrl	MCU SCU	801	Get the S/S command IF control word.
Returned Parameter(s)	Location	Length	
CmdIfCtrl	0	3	Bit 2: StatusRst Bit 1 : SubSystemRst Bit 0: DataIfReset

2.2.2.3. SubSDelay *

Command	Unit	Code	Description
GetSubSDelay	MCU SCU	802	Get the S/S command reception to response time expressed in low-level command interface clock periods
Returned Parameter(s)	Location	Length	
SubSDelay	0	9	Delay

* see note of the previous page

2.2.2.4. TstampRst

Command	Unit	Code	Description
SetTstampRst	All	003	Reset the 32-bit counter inserted in the S/S output data format. Nominally this command is send regularly to all the subsystems with the broadcast address to keep synchronisation between data packets.
Parameters	Location	Length	
NA	NA	NA	PAR15 to PAR00 = 00 hexa

2.2.3. DRCU generic commands parameter description

Name	Type	Size	Conversion	Limits	Description
LastCmdStatus	Discrete	2	See ACK definition table 2.1-d		Gives the status of the previous command (redundant with the ACK field)
SubSystemTimeout	Discrete	1	1=Error		Set when a time-out between the interface H/W and the subsystem itself has occurred for the previous (redundant with ACK field)
ForbiddenRead	Discrete	1	1=Forbidden		Set when S/S receives a GET command without asking for acknowledge (no nominal)
ForbiddenBroadcast	Discrete	1	1=Forbidden		Broadcast command is only allowed with SET. The flag is raised if S/S receive a GET command
CommandOverlapped	Discrete	1	1=Overlap		Set if the S/S receives a command before sending the acknowledge of the previous command
StatusRst	Discrete	1	0=Reset		Resets the CmdIFStatus register*
SubSystemRst*	Discrete	1	0=Reset		Reset the MCU DSP and the SCU digital H/W*
DataIfReset	Discrete	1	0=Reset		Reset the high speed interface*
SubSDelay	Digital	9	$Delay(s) = SubSDelay \cdot 3.2 \cdot 10^{-6}$		Delay between command reception & response transmission for the last received command

* caution : RESET bit is active low. To perform a reset a command with RESET=0 has to be sent followed by a second command with RESET=1 to stop reset.

2.2.4. DRCU typical commanding scenarios

NA

2.2.5. DCU specific command list summary

2.2.5.1. Command and parameter mapping

The following table shows respectively the bit mapping for CID and PAR field of a low-level command for the DCU.

CID11	CID10 to CID0	PAR15 to PAR9	PAR8 to PAR0
R/ \bar{W}	Command Code	-	Parameter(s)

Note: for the SetLIAPxOffset and SetLIASxOffset commands the *parameter* field is in turn divided into two sub-fields has described bellow:

PAR8 to PAR4	PAR3 to PAR0
Channel Number	Offset Value

CID10 is the command page bit: CID10 = 0 is for DRCU generic command codes while CID = 1 is for DCU specific command codes

2.2.5.2. Photometer write/read commands

Command Name	Argument(s)	Ranges List	Command verification	Execution Delay	CID
Set/GetPhotoSampFreq	Channel id Bias freq divider	NA 002 to 255	Get... cmd		418/C18
Set/GetPhotoBiasFreq	Channel id. Frequency divider	NA 064 to 511	Get... cmd		419/C19
Set/GetPhotoDemod	Ref. Channel id PSD Phase	0 to 3 000 to 255	Get... cmd		41A/C1A to 41D/C1D
Set/GetPhotoBiasMode	Channel id Bias gene mode	NA 000 to 255	Get... cmd		400
Set/GetPhotoBiasAmpl	Bias Channel id. Sine amplitude	00 to 03 000 to 255	Get... cmd		401/C01 to 404/C04
Set/GetPhSWJfetVss	Channel id. Vss voltage	0 to 5 000 to 255	Get... cmd		405/C05 to 40A/C0A
Set/GetPhMWJfetVss	Channel id. Vss voltage	0 to 3 000 to 255	Get... cmd		40B/C0B to40E/C0E
Set/GetPhLWJfetVss	Channel id. Vss voltage	0 to 3 000 to 255	Get... cmd		40F/C0F to 410/C10
Set/GetPhTCJfetVss	Channel id. Vss voltage	0 to 1 000 to 255	Get... cmd		414
Set/GetPhotoHeaterBias	Channel id. Bias current	NA 000 to 255	Get... cmd		411

Set/GetPhotoSWJfetPwr	Channel id On/Off word	00 to 01 NA - discrete	Get... cmd		412/C12
Set/GetPhotoMLWJfetPwr	Channel id On/Off word	00 to 01 NA - discrete	Get... cmd		413/C13
Set/GetLIAPxOffset	Channel id. Channel number Offset value	00 to 08 00 to 31 00 to 15	Get... cmd		420/C20 to 428/C28

2.2.5.3. Spectrometer write/read commands

Command Name	Argument(s)	Ranges List	Command verification	Execution Delay	CID
Set/GetSpectroSampFreq	Channel id Bias freq divider	NA 000 to 255	Get_... cmd		438/C38
Set/GetSpectroBiasFreq	Channel id. Frequency divider	NA 064 to 511	Get_... cmd		439/C39
Set/GetSpectroDemod	Channel id PSD Phase	0 to 1 000 to 255	Get_... cmd		43A/C3A to 43B/C3B
Set/GetSpectroBiasMode	Channel id Bias gene mode	NA 000 to 255	Get_... cmd		430
Set/GetSpectroBiasAmpl	Channel id. Sine amplitude	0 to 1 000 to 255	Get_... cmd		431/C31 to 432/C32
Set/GetSpectroHeaterBias	Channel id. Bias current	NA 000 to 255	Get_... cmd		433
Set/GetSpSWJfetVss	Channel id. Vss voltage	0 to 01 000 to 255	Get_... cmd		435/C35 to 436/C36
Set/GetSpLWJfetVss	Channel id. Vss voltage	NA 000 to 255	Get_... cmd		434/C37
Set/GetSpSLWJfetPwr	Channel id On/Off word	00 to 01 NA - discrete	Get_... cmd		437/C37
Set/GetLIASxOffset	Channel id. Channel number Offset value	00 to 02 00 to 23 00 to 15	Get_... cmd		42C/C2C to 42E/C2E

2.2.5.4. Photometer / spectrometer common write/read commands

Command Name	Argument(s)	Ranges List	Command verification	Execution Delay	CID
Set/GetDataMode	Channel id. Mode id.	NA NA - discrete	Get... cmd TBC		43C/C3C
Set/GetFrameNber	Channel id Nber of frames	NA 0 to 255	Get... cmd TBC		43D/C3D

Set/GetStartFrame	Channel id Run/Stop code	NA 000 / 255	Get... cmd TBC		43E/C3E
-------------------	-----------------------------	-----------------	-------------------	--	---------

2.2.5.5. Read only commands

Command Name	Argument(s)	Range	Execution Delay	CID
GetHKChannel	HK Channel id.		See §2.2.7.4	C3F

2.2.6. DCU command description

2.2.6.1. Photometer

2.2.6.1.1. *PhotoSampFreq*

Command	Unit	Code	Description
SetPhotoSampFreq	DCU	418	Set the photometer & T/C bolometer sampling frequency division from the photometer bias clock
Parameters	Location	Length	
PhotoBiasDiv	0	8	Sampling rate divider setting parameter (Min 2)

Command	Unit	Code	Description
GetPhotoSampFreq	DCU	C18	Get the photometer & T/C bolometer sampling frequency division from the photometer bias clock
Returned Parameters	Location	Length	
PhotoBiasDiv	0	8	

2.2.6.1.2. *PhotoBiasFreq*

Command	Unit	Code	Description
SetPhotoBiasFreq	DCU	419	Set the photometer & T/C bolometer sine bias frequency division from the master clock
Parameters	Location	Length	
PhotoMClkDiv	0	9	Master clock divider setting parameter (Min 64; Max 511)

Command	Unit	Code	Description
GetPhotoBiasFreq	DCU	C19	Get the photometer & T/C bolometer sine bias frequency division from the master clock
Returned Parameters	Location	Length	
PhotoMClkDiv	0	9	

2.2.6.1.3. *PhotoBiasMode*

Command	Unit	Code	Description
SetPhotoBiasMode	DCU	400	Set the photometer & T/C bolometer sine bias mode
Parameters	Location	Length	
PhotoBiasMode	0	8	FF=run ; 00=stop ; 01 to FE = discrete values

Command	Unit	Code	Description
GetPhotoBiasMode	DCU	C00	Get the photometer & T/C bolometer sine bias mode
Parameters	Location	Length	
PhotoBiasMode	0	8	FF=run ; 00=stop ; 01 to FE= test values

2.2.6.1.4. *PhotoDemodxx*

Command full name	Unit	Code	Description
SetPhotoDemodSW SetPhotoDemodMW SetPhotoDemodLW SetPhotoDemodTC	DCU	41A + x	Set the bolometer group demodulation phase shift x = 0 for SW group x = 1 for MW group x = 2 for LW group x = 3 for TC group
Parameters	Location	Length	
PhotoPhaseShiftxx	0	8	Phase shift register setting parameter
PhotoBiasChannel	-	-	Encoded with the command code (see x definition above)

Command full name	Unit	Code	Description
GetPhotoDemodSW GetPhotoDemodMW GetPhotoDemodLW GetPhotoDemodTC	DCU	C1A + x	Set bolometer group demodulation phase shift x = 0 for SW group x = 1 for MW group x = 2 for LW group x = 3 for TC group
Parameters	Location	Length	
PhotoBiasChannel	-	-	Encoded with the command code (see x definition above)
Returned Parameters			
PhotoPhaseShiftxx	0	8	

2.2.6.1.5. *PhotoBiasAmplxx*

Command full name	Unit	Code	Description
SetPhotoBiasAmplSW SetPhotoBiasAmplMW SetPhotoBiasAmplLW SetPhotoBiasAmplTC	DCU	401 + x	Set bolometer group sine bias amplitude x = 0 for SW group x = 1 for MW group x = 2 for LW group x = 3 for TC group
Parameters	Location	Length	
PhotoBiasAmplxx	0	8	Bias amplitude DAC setting parameter
PhotoBiasChannel	-	-	Encoded with the command code (see x definition above)

Command full name	Unit	Code	Description
GetPhotoBiasAmplSW GetPhotoBiasAmplMW GetPhotoBiasAmplLW GetPhotoBiasAmplTC	DCU	C01 + x	Set bolometer group sine bias amplitude x = 0 for SW group x = 1 for MW group x = 2 for LW group x = 3 for TC group
Parameters	Location	Length	
PhotoBiasChannel	-	-	Encoded with the command code (see x definition above)
Returned Parameters	Location	Length	
PhotoBiasAmplx	0	8	

2.2.6.1.6. *PhotoHeaterBias*

Command full name	Unit	Code	Description
SetPhotoHeaterBias	DCU	411	Set the photometer heater bias voltage
Parameters	Location	Length	
PhotoHeaterBias	0	8	JFET Heater DAC setting parameter

Command full name	Unit	Code	Description
GetPhotoHeaterBias	DCU	C11	Get the photometer heater bias voltage
Parameters	Location	Length	
PhotoHeaterBias	0	8	

2.2.6.1.7. *PhSWJfetVSSx*

Command full name	Unit	Code	Description
SetPhSWJfetVSS1 SetPhSWJfetVSS2 SetPhSWJfetVSS3 SetPhSWJfetVSS4 SetPhSWJfetVSS5 SetPhSWJfetVSS6	DCU	405 + x	Set PSW channels JFET source voltage x = 0 for VSS1 x = 1 for VSS2 x = 2 for VSS3 x = 3 for VSS4 x = 4 for VSS5 x = 5 for VSS6
Parameters	Location	Length	
PSW_VSSx	0	8	VSS DAC setting parameter
VSSChannelID	-	-	Encoded with the command code (see x definition above)

Command full name	Unit	Code	Description
GetPhSWJfetVSS GetPhSWJfetVSS2 GetPhSWJfetVSS3 GetPhSWJfetVSS4 GetPhSWJfetVSS5 GetPhSWJfetVSS6	DCU	C05	Get PSW channels JFET source voltage x = 0 for VSS1 x = 1 for VSS2 x = 2 for VSS3 x = 3 for VSS4 x = 4 for VSS5 x = 5 for VSS6
Parameters	Location	Length	
VSSChannelID	-	-	Encoded with the command code (see x definition above)
Returned Parameters			
PSW_VSSx	0	8	

2.2.6.1.8. *PhMWJfetVSSx*

Command full name	Unit	Code	Description
SetPhMWJfetVSS1 SetPhMWJfetVSS2 SetPhMWJfetVSS3 SetPhMWJfetVSS4	DCU	40B + x	Set PMW channel JFET source voltage x = 0 for VSS1 x = 1 for VSS2 x = 2 for VSS3 x = 3 for VSS4
Parameters	Location	Length	
PMW_VSSx	0	8	VSS DAC setting parameter
VSSChannelID	-	-	Encoded with the command code (see x definition above)

Command full name	Unit	Code	Description
GetPhMWJfetVSS1 GetPhMWJfetVSS2 GetPhMWJfetVSS3 GetPhMWJfetVSS4	DCU	C0B + x	Get PMW channels JFET source voltage x = 0 for VSS1 x = 1 for VSS2 x = 2 for VSS3 x = 3 for VSS4
Parameters	Location	Length	
VSSChannelID	-	-	Encoded with the command code (see x definition above)
Returned Parameters			
PMW_VSSx	0	8	

2.2.6.1.9. *PhLWJfetVSSx*

Command full name	Unit	Code	Description
SetPhLWJfetVSS1 SetPhLWJfetVSS2	DCU	40F + x	Set LW channels JFET source voltages x = 0 for VSS1 x = 1 for VSS2
Parameters	Location	Length	
PLW_VSSx	0	8	VSS DAC setting parameter
VSSChannelID	-	-	Encoded with the command code (see x definition above)

Command full name	Unit	Code	Description
GetPhLWJfetVSS1 GetPhLWJfetVSS2	DCU	C0F + x	Get LW channels JFET source voltages x = 0 for VSS1 x = 1 for VSS2
Parameters	Location	Length	
VSSChannelID	-	-	Encoded with the command code (see x definition above)
Returned Parameters			
PhLW_VSSx	0	8	

2.2.6.1.10. *PhTCJfetVSS*

Command full name	Unit	Code	Description
SetTCJfetVSS1	DCU	414	Set TC channels JFET source voltage

Parameters	Location	Length	
TC_VSS	0	8	VSS DAC setting parameter

Command full name	Unit	Code	Description
GetTCJfetVSS1	DCU	C14	Get TC channels JFET source voltage
Returned Parameters			
TC_VSS	0	8	

2.2.6.1.11. PhSWJfetPwr

Command	Unit	Code	Description
SetPhSWJfetPwr	DCU	412	Switch the PSW JFETs drain voltage on/off
Parameters	Location	Length	
PSW_JFET_1	0	1	JFET drain bias On/Off switch command
PSW_JFET_2	1	1	“
PSW_JFET_3	2	1	“
PSW_JFET_4	3	1	“
PSW_JFET_5	4	1	“
PSW_JFET_6	5	1	“

Command	Unit	Code	Description
GetPhSWJfetPwr	DCU	C12	Get the PSW JFETs drain voltage status
Parameters	Location	Length	
PSW_JFET_1	0	1	
PSW_JFET_2	1	1	
PSW_JFET_3	2	1	
PSW_JFET_4	3	1	
PSW_JFET_5	4	1	
PSW_JFET_6	5	1	

2.2.6.1.12. PhMLWJfetPwr

Command	Unit	Code	Description
SetPhMLWJfetPwr	DCU	413	Switch the PMW & PLW channels JFETs drain voltage on/off
Parameters	Location	Length	
PMW_JFET_1	0	1	JFET drain bias On/Off switch command
PMW_JFET_2	1	1	“
PMW_JFET_3	2	1	“
PMW_JFET_4	3	1	“
PLW_JFET_1	4	1	“
PLW_JFET_2	5	1	“
TC_JFET	6	1	“

Command	Unit	Code	Description
GetPhMLWJfetPwr	DCU	C13	Get the PMW & PLW channels JFETs drain voltage status
Parameters	Location	Length	
PMW_JFET_1	0	1	
PMW_JFET_2	1	1	
PMW_JFET_3	2	1	
PMW_JFET_4	3	1	

PLW_JFET_1	4	1	
PLW_JFET_2	5	1	
TC_JFET	6	1	

2.2.6.1.13. SetLIAPxOffset

Command	Unit	Code	Description
SetLIAP1Offset	DCU	420	Set one LIA_P1 channel offset value
Parameters	Location	Length	
Offset_P1	0	4	Offset value
Channel_P1	4	5	

Command	Unit	Code	Description
SetLIAP2Offset	DCU	421	Set one LIA_P2 channel offset value
Parameters	Location	Length	
Offset_P2	0	4	Offset value
Channel_P2	4	5	

Command	Unit	Code	Description
SetLIAP3Offset	DCU	422	Set one LIA_P3 channel offset value
Parameters	Location	Length	
Offset_P3	0	4	Offset value
Channel_P3	4	5	

Command	Unit	Code	Description
SetLIAP4Offset	DCU	423	Set one LIA_P4 channel offset value
Parameters	Location	Length	
Offset_P4	0	4	Offset value
Channel_P4	4	5	

Command	Unit	Code	Description
SetLIAP5Offset	DCU	424	Set one LIA_P5 channel offset value
Parameters	Location	Length	
Offset_P5	0	4	Offset value
Channel_P5	4	5	

Command	Unit	Code	Description
SetLIAP6Offset	DCU	425	Set one LIA_P6 channel offset value
Parameters	Location	Length	
Offset_P6	0	4	Offset value
Channel_P6	4	5	

Command	Unit	Code	Description
SetLIAP7Offset	DCU	426	Set one LIA_P7 channel offset value
Parameters	Location	Length	
Offset_P7	0	4	Offset value
Channel_P7	4	5	

Command	Unit	Code	Description
SetLIAP8Offset	DCU	427	Set one LIA_P8 channel offset value
Parameters	Location	Length	
Offset_P8	0	4	Offset value
Channel_P8	4	5	

Command	Unit	Code	Description
SetLIAP9Offset	DCU	428	Set one LIA_P9 channel offset value
Parameters	Location	Length	
Offset_P9	0	4	Offset value
Channel_P9	4	5	

Note: GetLIAPxOffset is not implemented – In the same manner the response to a SetLIAPxOffset command will return a null parameter. Offset setting can be checked by switching to the appropriate DCU data mode.

2.2.6.2. LIA_P channel/Bolometer number cross table

Channel Number	LIAP1 Bolometer Number	LIAP2 Bolometer Number	LIAP3 Bolometer Number	LIAP4 Bolometer Number	LIAP5 Bolometer Number	LIAP6 Bolometer Number	LIAP7 Bolometer Number	LIAP8 Bolometer Number	LIAP9 Bolometer Number
1	PSW_xxx	PSW_xxx	PSW_xxx	PSW_xxx	PSW_xxx	PLW_xxx	PMW_xxx	PMW_xxx	PMW_xxx
2	PSW_xxx	PSW_xxx	PSW_xxx	PSW_xxx	PSW_xxx	PLW_xxx	PMW_xxx	PMW_xxx	PMW_xxx
3	PSW_xxx	PSW_xxx	PSW_xxx	PSW_xxx	PSW_xxx	PLW_xxx	PMW_xxx	PMW_xxx	PMW_xxx
4	PSW_xxx	PSW_xxx	PSW_xxx	PSW_xxx	PSW_xxx	PLW_xxx	PMW_xxx	PMW_xxx	PMW_xxx
5	PSW_xxx	PSW_xxx	PSW_xxx	PSW_xxx	PSW_xxx	PLW_xxx	PMW_xxx	PMW_xxx	PMW_xxx
6	PSW_xxx	PSW_xxx	PSW_xxx	PSW_xxx	PSW_xxx	PLW_xxx	PMW_xxx	PMW_xxx	PMW_xxx
7	PSW_xxx	PSW_xxx	PSW_xxx	PSW_xxx	PSW_xxx	PLW_xxx	PMW_xxx	PMW_xxx	PMW_xxx
8	PSW_xxx	PSW_xxx	PSW_xxx	PSW_xxx	PSW_xxx	PLW_xxx	PMW_xxx	PMW_xxx	PMW_xxx
9	PSW_xxx	PSW_xxx	PSW_xxx	PSW_xxx	PSW_xxx	PLW_xxx	PMW_xxx	PMW_xxx	PMW_xxx
10	PSW_xxx	PSW_xxx	PSW_xxx	PSW_xxx	PSW_xxx	PLW_xxx	PMW_xxx	PMW_xxx	PMW_xxx
11	PSW_xxx	PSW_xxx	PSW_xxx	PSW_xxx	PSW_xxx	PLW_xxx	PMW_xxx	PMW_xxx	PMW_xxx
12	PSW_xxx	PSW_xxx	PSW_xxx	PSW_xxx	PSW_xxx	PLW_xxx	PMW_xxx	PMW_xxx	PMW_xxx
13	PSW_xxx	PSW_xxx	PSW_xxx	PSW_xxx	PSW_xxx	PLW_xxx	PMW_xxx	PMW_xxx	PMW_xxx
14	PSW_xxx	PSW_xxx	PSW_xxx	PSW_xxx	PSW_xxx	PLW_xxx	PMW_xxx	PMW_xxx	PMW_xxx
15	PSW_xxx	PSW_xxx	PSW_xxx	PSW_xxx	PSW_xxx	PLW_xxx	PMW_xxx	PMW_xxx	PMW_xxx
16	PSW_xxx	PSW_xxx	PSW_xxx	PSW_xxx	PSW_xxx	PLW_xxx	PMW_xxx	PMW_xxx	PMW_xxx
17	PSW_xxx	PSW_xxx	PSW_xxx	PSW_xxx	PLW_xxx	PLW_xxx	PMW_xxx	PMW_xxx	PMW_xxx
18	PSW_xxx	PSW_xxx	PSW_xxx	PSW_xxx	PLW_xxx	PLW_xxx	PMW_xxx	PMW_xxx	PMW_xxx
19	PSW_xxx	PSW_xxx	PSW_xxx	PSW_xxx	PLW_xxx	PLW_xxx	PMW_xxx	PMW_xxx	PMW_xxx
20	PSW_xxx	PSW_xxx	PSW_xxx	PSW_xxx	PLW_xxx	PLW_xxx	PMW_xxx	PMW_xxx	PMW_xxx
21	PSW_xxx	PSW_xxx	PSW_xxx	PSW_xxx	PLW_xxx	PLW_xxx	PMW_xxx	PMW_xxx	PMW_xxx
22	PSW_xxx	PSW_xxx	PSW_xxx	PSW_xxx	PLW_xxx	PLW_xxx	PMW_xxx	PMW_xxx	PMW_xxx
23	PSW_xxx	PSW_xxx	PSW_xxx	PSW_xxx	PLW_xxx	PLW_xxx	PMW_xxx	PMW_xxx	PMW_xxx
24	PSW_xxx	PSW_xxx	PSW_xxx	PSW_xxx	PLW_xxx	PLW_xxx	PMW_xxx	PMW_xxx	PMW_xxx
25	PSW_xxx	PSW_xxx	PSW_xxx	PSW_xxx	PLW_xxx	PLW_xxx	PMW_xxx	PMW_xxx	PMW_xxx
26	PSW_xxx	PSW_xxx	PSW_xxx	PSW_xxx	PLW_xxx	PLW_xxx	PMW_xxx	PMW_xxx	PMW_xxx
27	PSW_xxx	PSW_xxx	PSW_xxx	PSW_xxx	PLW_xxx	PLW_xxx	PMW_xxx	PMW_xxx	PMW_xxx
28	PSW_xxx	PSW_xxx	PSW_xxx	PSW_xxx	PLW_xxx	PLW_xxx	PMW_xxx	PMW_xxx	PMW_xxx
29	PSW_xxx	PSW_xxx	PSW_xxx	PSW_xxx	PLW_xxx	PLW_xxx	PMW_xxx	PMW_xxx	PMW_xxx
30	PSW_xxx	PSW_xxx	PSW_xxx	PSW_xxx	PLW_xxx	PLW_xxx	PMW_xxx	PMW_xxx	PMW_xxx
31	PSW_xxx	PSW_xxx	PSW_xxx	PSW_xxx	PLW_xxx	PLW_xxx	PMW_xxx	PMW_xxx	PMW_xxx
32	PSW_xxx	PSW_xxx	PSW_xxx	PSW_xxx	PLW_xxx	PLW_xxx	PMW_xxx	PMW_xxx	PMW_xxx

2.2.6.3. Spectrometer

2.2.6.3.1. SpectroSampFreq

Command	Unit	Code	Description
SetSpectroSampFsreq	DCU	438	Set the spectrometer bolometer sampling frequency division from the spectrometer bias clock
Parameters	Location	Length	
SpectroBiasDiv	0	8	Sampling rate divider setting parameter

Command	Unit	Code	Description
GetSpectroSampFreq	DCU	C38	Get the photometer & T/C bolometer sampling frequency division from the photometer bias clock
Parameters	Location	Length	
SpectroBiasDiv	0	8	

2.2.6.3.2. SpectroBiasFreq

Command	Unit	Code	Description
SetSpectroBiasFreq	DCU	439	Set the spectrometer bolometer sine bias frequency division from the master clock
Parameters	Location	Length	
SpectroMClkDiv	0	9	Master clock divider setting parameter (Min 64; Max 511)

Command	Unit	Code	Description
GetSpectroBiasFreq	DCU	C39	Get the spectrometer bolometer sine bias frequency division from the master clock
Parameters	Location	Length	
SpectroMClkDiv	0	9	

2.2.6.3.3. SpectroBiasMode

Command	Unit	Code	Description
SetSpectroBiasMode	DCU	430	Set the spectrometer bolometer sine bias mode
Parameters	Location	Length	
SpectroBiasMode	0	8	FF=run ; 00=stop ; 01 to FE = test values

Command	Unit	Code	Description
GetSpectroBiasMode	DCU	C30	Get the spectrometer bolometer sine bias mode
Parameters	Location	Length	
SpectroBiasMode	0	8	FF=run ; 00=stop ; 01 to FE = test values

2.2.6.3.4. *SpectroDemodxx*

Command	Unit	Code	Description
SetSpectroDemodSW SetSpectroDemodLW	DCU	43A + x	Set the S-SW bolometer demodulation phase shift x = 0 for SW group x = 1 for LW group
Parameters	Location	Length	
SpectroPhaseShiftxx	0	8	Phase shift register setting parameter
SpectroBiasChannel	-	-	Encoded with the command code (see x definition above)

Command	Unit	Code	Description
GetSpectroDemodSW GetSpectroDemodLW	DCU	C3A + x	Get the S-SW bolometer demodulation phase shift x = 0 for SW group x = 1 for LW group
Parameters	Location	Length	
SpectroBiasChannel	-	-	Encoded with the command code (see x definition above)
Returned Parameters	Location	Length	
SpectroPhaseShift	0	8	

2.2.6.3.5. *SpectroBiasAmplx*

Command	Unit	Code	Description
SetSpectroBiasAmplSW SetSpectroBiasAmplLW	DCU	431 + x	Set bolometer group sine bias amplitude x = 0 for SW group x = 1 for LW group
Parameters	Location	Length	
SpectroBiasAmplx	0	8	Bias amplitude DAC setting parameter
SpectroBiasChannel	-	-	Encoded with the command code (see x definition above)

Command	Unit	Code	Description
GetSpectroBiasAmplSW GetSpectroBiasAmplLW	DCU	C31 + x	Get bolometer group sine bias amplitude x = 0 for SW group x = 1 for LW group
Parameters	Location	Length	
SpectroBiasChannel	-	-	Encoded with the command code (see x definition above)
Returned Parameters	Location	Length	
SpectroBiasAmplx	0	8	

2.2.6.3.6. *SpectroHeaterBias*

Command	Unit	Code	Description
SetSpectroHeaterBias	DCU	433	Set the spectrometer heater bias voltage
Parameters	Location	Length	
SpectroHeaterBias	0	8	JFET Heater DAC setting parameter

Command	Unit	Code	Description
GetSpectroHeaterBias	DCU	C33	Get the spectrometer heater bias voltage
Parameters	Location	Length	
SpectroHeaterBias	0	8	

2.2.6.3.7. *SpSWJfetVSSx*

Command full name	Unit	Code	Description
SetSpSWJfetVSS1 SetSpSWJfetVSS2	DCU	435 + x	Set SSW JFET source voltage x = 0 for VSS1 x = 1 for VSS2
Parameters	Location	Length	
SSW_VSSx	0	8	VSS DAC setting parameter
VSSChannelID	-	-	Encoded with the command code (see x definition above)

Command full name	Unit	Code	Description
GetSpSWJfetVSS1 GetSpSWJfetVSS2	DCU	C35 + x	Get SSW JFET source voltage x = 0 for VSS1 x = 1 for VSS2
Parameters	Location	Length	
VSSChannelID	-	-	Encoded with the command code (see x definition above)
Returned Parameters			
SSW_VSSx	0	8	

2.2.6.3.8. *SpLWJfetVSS*

Command	Unit	Code	Description
SetSpLWJfetVSS	DCU	434	Set SLW JFET source voltage
Parameters	Location	Length	
SLW_VSS	0	8	

Command	Unit	Code	Description
GetSpLWJfetVSS	DCU	C34	Get SLW JFET source voltage
Returned Parameters	Location	Length	
SLW_VSS	0	8	

2.2.6.3.9. *SpSLWJfetPwr*

Command	Unit	Code	Description
SetSpSLWJfetPwr	DCU	437	Switch the spectrometer JFET's drain voltage on/off
Parameters	Location	Length	
SLW_JFET1	0	1	JFET drain bias On/Off switch command
SSW_JFET1	1	1	“
SSW_JFET2	2	1	“

Command	Unit	Code	Description
GetSpSLWJfetPwr	DCU	C37	Get the spectrometer JFET's drain voltage status

Parameters	Location	Length	
SLW_JFET1	0	1	
SSW_JFET1	1	1	
SSW_JFET2	2	1	

2.2.6.3.10. SetLIASxOffset

Command	Unit	Code	Description
SetLIAS1Offset	DCU	42C	Set one LIA_S1 channel offset value
Parameters	Location	Length	
Offset_S1	0	4	Offset value
Channel_S1	4	5	

Command	Unit	Code	Description
SetLIAS2Offset	DCU	42D	Set one LIA_S2 channel offset value
Parameters	Location	Length	
Offset_S2	0	4	Offset value
Channel_S2	4	5	

Command	Unit	Code	Description
SetLIAS3Offset	DCU	42E	Set one LIA_S3 channel offset value
Parameters	Location	Length	
Offset_S3	0	4	Offset value
Channel_S3	4	5	

Note: GetLIASxOffset is not implemented – In the same manner the response to a SetLIASxOffset command will return a null parameter. Offset setting can be checked by switching to the appropriate DCU data mode.

2.2.6.4. LIA_S channel/Bolometer number cross table

	LIAS1	LIAS2	LIAS3		LIAS1	LIAS2	LIAS3
Channel Number	Bolometer Number	Bolometer Number	Bolometer Number	Channel Number	Bolometer Number	Bolometer Number	Bolometer Number
1	SSW_XXX	SSW_XXX	SLW_XXX	1	SSW_XXX	SSW_XXX	SLW_XXX
2	SSW_XXX	SSW_XXX	SLW_XXX	2	SSW_XXX	SSW_XXX	SLW_XXX
3	SSW_XXX	SSW_XXX	SLW_XXX	3	SSW_XXX	SSW_XXX	SLW_XXX
4	SSW_XXX	SSW_XXX	SLW_XXX	4	SSW_XXX	SSW_XXX	SLW_XXX
5	SSW_XXX	SSW_XXX	SLW_XXX	5	SSW_XXX	SSW_XXX	SLW_XXX
6	SSW_XXX	SSW_XXX	SLW_XXX	6	SSW_XXX	SSW_XXX	SLW_XXX
7	SSW_XXX	SSW_XXX	SLW_XXX	7	SSW_XXX	SSW_XXX	SLW_XXX
8	SSW_XXX	SSW_XXX	SLW_XXX	8	SSW_XXX	SSW_XXX	SLW_XXX
9	SSW_XXX	SSW_XXX	SLW_XXX	9	SSW_XXX	SSW_XXX	SLW_XXX
10	SSW_XXX	SSW_XXX	SLW_XXX	10	SSW_XXX	SSW_XXX	SLW_XXX

11	SSW_xxx	SSW_xxx	SLW_xxx	11	SSW_xxx	SSW_xxx	SLW_xxx
12	SSW_xxx	SSW_xxx	SLW_xxx	12	SSW_xxx	SSW_xxx	SLW_xxx

2.2.6.5. Photometer & Spectrometer common commands

2.2.6.5.1. *DataMode*

Command	Unit	Code	Description
SetDataMode	DCU	43C	Set the DCU output data format between bolometer or 4-bit offset transmission and test patten.
Parameters	Location	Length	
DataMode	0	5	<u>Bit 4:</u> offset <u>Bit 3:</u> test pattern <u>Bit 2 to 0:</u> data type

Command	Unit	Code	Description
GetDataMode	DCU	C3C	Get DCU data mode
Parameters	Location	Length	
DataMode	0	5	<u>Bit 4:</u> offset <u>Bit 3:</u> test pattern <u>Bit 2 to 0:</u> data type

2.2.6.5.2. *FrameCount*

Command	Unit	Code	Description
SetFrameNber	DCU	43D	Set photometer frames acquisition mode
Parameters	Location	Length	
FrameCount	0	8	0 = continuous 1 to 255 =number of frames

Command	Unit	Code	Description
GetFrameCount	DCU	C3D	Get photometer frames acquisition mode
Parameters	Location	Length	
FrameCount	0	8	0 = continuous 1 to 255 =number of frames

2.2.6.5.3. *StartFrame*

Command	Unit	Code	Description
SetStartFrame	DCU	43E	
Parameters	Location	Length	
StartFrame	0	1	1 = run 0 = stop

Command	Unit	Code	Description
GetStartFrame	DCU	C3E	
Parameters	Location	Length	
Startframe	0	1	1 = run 0 = stop

2.2.6.5.4. *GetHKChannel*

Command	Unit	Code	Description
GetHKChannel	DCU	C3F	Get DCU internal housekeepings
Parameters	Location	Length	
HKChannel	0	5	See table §2.2.7.4

2.2.7. DCU parameters description

2.2.7.1. Photometer

Name	Type	Size	Conversion	Limits	Description
PhotoDivBias	Analogue	8	$F_{\text{sampl}}(\text{Hz}) = \frac{F_{\text{bias}}}{1 + \text{PhotoDivBias}}$	2 to 255	0.15 Hz ≤ Fsampl ≤ 305 Hz
PhotoMClkDiv	Analogue	9	$F_{\text{BIAS}}(\text{Hz}) = \frac{10^7}{512.(\text{PhotoMClkDiv} + 1)}$	64 to 511	38 Hz ≤ Fbias ≤ 305 Hz
PhotoBiasMode	Discrete	8	FF = run sine 00 to FE = DC level	0 to 255	
PhotoDemodSW PhotoDemodMW PhotoDemodLW PhotoDemodTC	Analogue	8	$Ph_{\text{ct}}(\text{deg}) = 360 \frac{\text{PhotoDemodtxx}}{255}$	0 to 255	
PhotoBiasAmplSW PhotoBiasAmplMW PhotoBiasAmplLW PhotoBiasAmplTC	Analogue	8	$V_{\text{bxx}} = V_{\text{bmax}} \frac{\text{PhotoBiasAmplx}}{255}$	0 to 255	Vbmax = 200 mV pp
PhotoHeaterBias	Analogue	8	$Vh = Vh_{\text{max}} \frac{\text{PhotoHeaterBias}}{255}$	0 to 255	Vhmax = -5 V
PSW_VSS1 PSW_VSS2 PSW_VSS3 PSW_VSS4 PSW_VSS5 PSW_VSS6	Analogue	8	$VSS_{\text{ct}} = VSS_{\text{max}} \frac{\text{PSW_VSSx}}{255}$	0 to 255	Vssmax = -5 V
PMW_VSS1 PMW_VSS2 PMW_VSS3 PMW_VSS4	Analogue	8	$VSS_{\text{ct}} = VSS_{\text{max}} \frac{\text{PMW_VSSxx}}{255}$	0 to 255	Vssmax = -5 V
PLW_VSS1 PLW_VSS2	Analogue	8	$VSS_{\text{ct}} = VSS_{\text{max}} \frac{\text{PLW_VSSx}}{255}$	0 to 255	Vssmax = -5 V
PSW_JFET_1	Discrete	1	0=off ; 1=on	0/1	
PSW_JFET_2	Discrete	1	0=off ; 1=on	0/1	
PSW_JFET_3	Discrete	1	0=off ; 1=on	0/1	
PSW_JFET_4	Discrete	1	0=off ; 1=on	0/1	
PSW_JFET_5	Discrete	1	0=off ; 1=on	0/1	
PSW_JFET_6	Discrete	1	0=off ; 1=on	0/1	
PMW_JFET_1	Discrete	1	0=off ; 1=on	0/1	
PMW_JFET_2	Discrete	1	0=off ; 1=on	0/1	
PMW_JFET_3	Discrete	1	0=off ; 1=on	0/1	
PMW_JFET_4	Discrete	1	0=off ; 1=on	0/1	
PLW_JFET_1	Discrete	1	0=off ; 1=on	0/1	
PLW_JFET_2	Discrete	1	0=off ; 1=on	0/1	
Channel_P1	Discrete	5	Channel 1 to 32 of LIA_P1	0 to 31	
Channel_P2	Discrete	5	Channel 1 to 32 of LIA_P2	0 to 31	

Channel_P3	Discrete	5	Channel 1 to 32 of LIA_P3	0 to 31	
Channel_P4	Discrete	5	Channel 1 to 32 of LIA_P4	0 to 31	
Channel_P5	Discrete	5	Channel 1 to 32 of LIA_P5	0 to 31	
Channel_P6	Discrete	5	Channel 1 to 32 of LIA_P6	0 to 31	
Channel_P7	Discrete	5	Channel 1 to 32 of LIA_P7	0 to 31	
Channel_P8	Discrete	5	Channel 1 to 32 of LIA_P8	0 to 31	
Channel_P9	Discrete	5	Channel 1 to 32 of LIA_P9	0 to 31	
Offset_P1	Analogue	4	$V_{Offset_Px} = V_{Offsetmax} \frac{Offset_Px}{15}$	0 to 15	$V_{Offsetmax} = 5$ V
Offset_P2	Analogue	4	$V_{Offset_Px} = V_{Offsetmax} \frac{Offset_Px}{15}$	0 to 15	$V_{Offsetmax} = 5$ V
Offset_P3	Analogue	4	$V_{Offset_Px} = V_{Offsetmax} \frac{Offset_Px}{15}$	0 to 15	$V_{Offsetmax} = 5$ V
Offset_P4	Analogue	4	$V_{Offset_Px} = V_{Offsetmax} \frac{Offset_Px}{15}$	0 to 15	$V_{Offsetmax} = 5$ V
Offset_P5	Analogue	4	$V_{Offset_Px} = V_{Offsetmax} \frac{Offset_Px}{15}$	0 to 15	$V_{Offsetmax} = 5$ V
Offset_P6	Analogue	4	$V_{Offset_Px} = V_{Offsetmax} \frac{Offset_Px}{15}$	0 to 15	$V_{Offsetmax} = 5$ V
Offset_P7	Analogue	4	$V_{Offset_Px} = V_{Offsetmax} \frac{Offset_Px}{15}$	0 to 15	$V_{Offsetmax} = 5$ V
Offset_P8	Analogue	4	$V_{Offset_Px} = V_{Offsetmax} \frac{Offset_Px}{15}$	0 to 15	$V_{Offsetmax} = 5$ V
Offset_P9	Analogue	4	$V_{Offset_Px} = V_{Offsetmax} \frac{Offset_Px}{15}$	0 to 15	$V_{Offsetmax} = 5$ V

Values on yellow background indicates default power-on settings

2.2.7.2. Spectrometer

Name	Type	Size	Conversion	Limits	Description
SpectroBiasDiv	Analogue	8	$F_{sampler} = \frac{F_{bias}}{1 + SpectroBiasDiv}$	2 to 255	0.15 Hz ≤ Fsampler ≤ 305 Hz
SpectroMClkDiv	Analogue	9	$F_{BIAS} = \frac{10^7}{512.(SpectroMClkDiv + 1)}$	64 to 511	38 Hz ≤ Fbias ≤ 305 Hz
SpectroBiasMode	Discrete	8	FF = run sine 00 to FE = DC level	0 to 254	-Vbxx/2 to +Vbxx/2 *
SpectroDemod	Analogue	8	$Ph_{xx} = 360 \cdot \frac{SpectroPhaseShift_{xx}}{255}$	0 to 255	0 to 360° by 1.41° steps
SpectroBiasAmplSW SpectroBiasAmplLW	Analogue	8	$Vb_{xx} = Vb_{max} \cdot \frac{SpectroBiasAmpl_{xx}}{255}$	0 to 255	Vbmax = 200 mV pp
SpectroHeaterBias	Analogue	8	$Vh_{xx} = Vh_{max} \cdot \frac{SpectroHeaterBias}{255}$	0 to 255	Vhmax = -5 V
SLW_VSS1 SLW_VSS2	Analogue	8	$VSS_x = VSS_{max} \cdot \frac{SLW_VSS_x}{255}$	0 to 255	Vssmax = -5 V
SSW_VSS	Analogue	8	$VSS = VSS_{max} \cdot \frac{SLW_VSS}{255}$	0 to 255	Vssmax = -5 V
SLW_JFET1	Discrete	1	0=off ; 1=on	0/1	
SSW_JFET1	Discrete	1	0=off ; 1=on	0/1	
SSW_JFET2	Discrete	1	0=off ; 1=on	0/1	
Channel_S1	Discrete	5	Channel 1 to 24 of LIA_S1	0 to 23	
Channel_S2	Discrete	5	Channel 1 to 24 of LIA_S2	0 to 23	
Channel_S3	Discrete	5	Channel 1 to 24 of LIA_S3	0 to 23	
Offset_S1	Analogue	4	$V_{Offset_Sx} = V_{Offset\ max} \cdot \frac{Offset_Sx}{15}$	0 to 15	V _{Offsetmax} = 5 V
Offset_S2	Analogue	4	$V_{Offset_Sx} = V_{Offset\ max} \cdot \frac{Offset_Sx}{15}$	0 to 15	V _{Offsetmax} = 5 V
Offset_S3	Analogue	4	$V_{Offset_Sx} = V_{Offset\ max} \cdot \frac{Offset_Sx}{15}$	0 to 15	V _{Offsetmax} = 5 V

Values on yellow background indicates default power-on settings

* : parameter is signed

Setting	Output Level
FE	$\frac{+Vb_{xx}}{2}$
EF	0
00	$\frac{-Vb_{xx}}{2}$

2.2.7.3. Photometer & Spectrometer

Name	Type	Size	Conversion	Limits	Description
DataMode	Discrete	5	00= acquisition photometer 01= acquisition PSW 02= acquisition PMW 03= acquisition PLW 04= acquisition Spectrometer 05= acquisition SLW 06= acquisition SSW 08= Test Pattern photometer 0C= Test Pattern Spectrometer 10= Automatic offset photometer set 14= Automatic offset spectrometer set 18= Get offset photometer 1C= Get offset spectrometer Other = do nothing	0 to 1C	
FrameCount	Discrete	8	0 = continuous; 1 to 255 = number of frames	0 to 255	
StartFrame	Discrete	1	1 = run 0 = stop	0/1	
HKChannel	Discrete		See table §2.2.7.4	0 to 26	

Values on yellow background indicates default power-on settings

2.2.7.4. DCU housekeeping identifier list

The following table lists the *HKChannel* id to be transmitted as an argument of the *GetHKChannel* command.

Parameter Name	Size (bits)	Comments	Channel ID (hex)	Delay To Transmit
BIAS_TEMP	16	BIAS board temperature	00	≤ 150 μs
LIA_S1_TEMP	16	LIA board 10 temperature	01	≤ 150 μs
LIA_S2_TEMP	16	LIA board 11 temperature	02	≤ 150 μs
LIA_S3_TEMP	16	LIA board 12 temperature	03	≤ 150 μs
LIA_P9_TEMP	16	LIA board 1 temperature	04	≤ 150 μs
LIA_P8_TEMP	16	LIA board 2 temperature	05	≤ 150 μs
LIA_P7_TEMP	16	LIA board 3 temperature	06	≤ 150 μs
LIA_P6_TEMP	16	LIA board 4 temperature	07	≤ 150 μs
LIA_P5_TEMP	16	LIA board 5 temperature	08	≤ 150 μs
LIA_P4_TEMP	16	LIA board 6 temperature	09	≤ 150 μs
LIA_P3_TEMP	16	LIA board 7 temperature	0A	≤ 150 μs
LIA_P2_TEMP	16	LIA board 8 temperature	0B	≤ 150 μs
LIA_P1_TEMP	16	LIA board 9 temperature	0C	≤ 150 μs
DAQ_IF_TEMP	16	DAQ_IF board temperature	0D	≤ 150 μs
BDAQ_P5	16	BIAS/DAQ_IF +5V voltage	0E	≤ 150 μs
BQAD_P9	16	BIAS/DAQ_IF +9V voltage	0F	≤ 150 μs
BDAQ_N9	16	BIAS/DAQ_IF -9V voltage	10	≤ 150 μs
LIAP_P5	16	LIAP +5V voltage (before post regulator)	11	≤ 150 μs
LIAP_P9	16	LIAP +9V voltage (before post regulator)	12	≤ 150 μs
LIAP_N9	16	LIAP -9V voltage (before post regulator)	13	≤ 150 μs
LIAS_P5	16	LIAS +5V voltage (before post regulator)	14	≤ 150 μs
LIAS_P9	16	LIAS +9V voltage (before post regulator)	15	≤ 150 μs
LIAS_N9	16	LIAS -9V voltage (before post regulator)	16	≤ 150 μs
PWR_STATUS	12	LIA 1 to LIA 12 +5V/+9V/-9V status	17	≤ 150 μs
T/C_1	16	16-bit ADC (Offset=0)	1A	≤ 150 μs
T/C_2	16	16-bit ADC (Offset=0)	1C	≤ 150 μs
T/C_3	16	16-bit ADC (Offset=0)	1E	≤ 150 μs

2.2.7.5. PWR_STATUS word definition

MSB	Bit 14	Bit 13	Bit 12	Bit 11	Bit 10	Bit 9	Bit 8	Bit 7	Bit 6	Bit 5	Bit 4	Bit 0 to 3
LIA_P1	LIA_P2	LIA_P3	LIA_P4	LIA_P5	LIA_P6	LIA_P7	LIA_P8	LIA_P9	LIA_S1	LIA_S2	LIA_S3	0

Flag status: 0 = OK / 1 = over-current ($I \geq 400$ mA)

A raised flag “1” indicates that the corresponding LIA power supplies is off. The fault condition is latched. Reset of the latch requires a power-off/power-on sequence.

2.2.7.6. DCU boards temperature conversion

The transfer function for housekeeping channel related to DCU board temperatures (channels 0x00 to 0x0D) is:

With HK the value returned by the GetHKChannel command
With T the board temperature expressed in °C

$$T = HK \cdot 1.526 \cdot 10^{-2} - 773$$

2.2.7.7. DCU supply voltages conversion

The transfer function for housekeeping channel related to DCU supply voltage (channels 0x0E to 0x16) is:

With HK the value returned by the GetHKChannel command
With V the board temperature expressed in volts

$$T = HK \cdot 4.577 \cdot 10^{-4} - 15$$

2.2.7.8. T/C channel conversion

T/C housekeeping channels are copies of data from photometer frames. T/C 1, T/C 2 & T/C 3 correspond respectively to Channel 30, 31 & 32 of the LIA P9 board.

Transfer function is then identical to the one defined in §2.3.5.3.1.

2.2.8. DCU typical commanding scenarios

2.2.8.1. DCU Configuration

2.2.8.1.1. Photometer

Steps	Command	Parameters	Comment
1	SetPhotoBiasFreq	PhotoMClkDiv	With a 10 MHz master clock for a photometer bias frequency of 199.3Hz; PhotoMClkDiv = 98
2	SetPhotoSampFreq	PhotoBiasDiv	Set a sampling frequency of 15,3Hz; PhotoBiasDiv = 13
3	SetPhotoDemod	PSW PhotoPhaseShiftSW	The optimised phases shift for each possible bias frequency must be set in a table during the ground calibration (448 cases of each type of BDA)
4	SetPhotoDemod	PMW PhotoPhaseShiftMW	
5	SetPhotoDemod	PLW PhotoPhaseShiftLW	
6	SetPhotoDemod	T/C PhotoPhaseShiftTC	
7	SetPhotoBiasAmpl	PSW PhotoBiasAmplPSW	Optimised amplitude could be determined during the ground calibration
8	SetPhotoBiasAmpl	PMW PhotoBiasAmplPMW	
9	SetPhotoBiasAmpl	PLW PhotoBiasAmplPLW	
10	SetPhotoBiasAmpl	T/C PhotoBiasAmplTC	
11	SetPhSWJfetVSS	VSS1 PSW_VSS1	Optimised amplitude could be determined during the ground calibration
12	SetPhSWJfetVSS	VSS2 PSW_VSS2	
13	SetPhSWJfetVSS	VSS3 PSW_VSS3	
14	SetPhSWJfetVSS	VSS4 PSW_VSS4	
15	SetPhSWJfetVSS	VSS5 PSW_VSS5	
16	SetPhSWJfetVSS	VSS6 PSW_VSS6	
17	SetPhMWJfetVSS	VSS1 PMW_VSS1	
18	SetPhMWJfetVSS	VSS2 PMW_VSS2	
19	SetPhMWJfetVSS	VSS3 PMW_VSS3	

20	SetPhMWJfetVSS	VSS4 PMW_VSS4	
21	SetPhLWJfetVSS	VSS1 PLW_VSS1	
22	SetPhLWJfetVSS	VSS2 PLW_VSS2	
23	SetSWJfetPwr	PSW_JFET	All JFET on (PSW_JFET=111111)
24	SetMLWJfetPwr	PMLW_JFET	All JFET on (PMLW_JFET=111111)
25	SetPhotoBiasMode	PhotoBiasMode	Mode = EF (DAC mid-scale = 0 V)
26	SetPhotoHeaterBias	PhotoHeaterBias	Start heating the photometer JFET modules Set PhotoHeaterBias with xx
	Wait xx ms		
27	SetPhotoHeaterBias	PhotoHeaterBias	Stop heating the photometer JFET modules Set PhotoHeaterBias with 00

2.2.8.1.2. *Spectrometer*

Steps	Command	Parameters	Comment
28	SetSpectroBiasFreq	SpectroMClkDiv	With a 10 MHz master clock for a photometer bias frequency of 160,1 Hz; SpectroMClkDiv = 122
29	SetSpectroSampIFreq	SpectroBiasDiv	Set a sampling frequency of 80 Hz; SpectroBiasDiv = 2
30	SetSpectroDemod	SW SpectroPhaseShiftSW	The optimised phases shift for each possible bias frequency must be set in a table during the ground calibration (448 cases of each type of BDA)
31	SetSpectroDemod	LW SpectroPhaseShiftLW	
32	SetSpectroBiasAmpl	SW SpectroBiasAmplSW	Optimised amplitude could be determine during the ground calibration
33	SetSpectroBiasAmpl	LW SpectroBiasAmplLW	
34	SetSpLWJfetVSS	VSS SLW_VSS	Optimised amplitude could be determine during the ground calibration
35	SetSpSWJfetVSS	VSS1 SSW_VSS2	
36	SetSpSWJfetVSS	VSS2 SSW_VSS2	
37	SetSpectroJfetPwr	SSLW_JFET	All JFET on (SSLW_JFET =111111)
38	SetSpectroBiasMode	SpectroBiasMode	Mode = EF (DAC mid scale)
39	SetSpectroHeaterBias	SpectroHeaterBias	Start heating the spectrometer JFET modules Set SpectroHeaterBias with xx
	Wait xx ms		
40	SetSpectroHeaterBias	SpectroHeaterBias	Stop heating the spectrometer JFET modules Set SpectroHeaterBias with 00

After execution of all these steps the spectrometer and the photometer JFETs are running. All the sine bias parameters and acquisition parameters are loaded and the bolometers biases receive a differential 0V. Next step: start running the spectrometer or the photometer.

2.2.8.2. Photometer Configuration

Steps	Command	Parameters	Comment
1	SetPhotoBiasMode	PhotoBiasMode	Mode = FF
	Wait xx ms		After this time the system must be stable

2.2.8.3. Photometer offset setting

2.2.8.3.1. Automatic

Steps	Command	Parameters	Comment
1	SetStartFrame	Start	Start=0 - stop/confirm stop sending frames
2	SetDataMode	Mode	Mode = 10 - automatic offset for photo
2'	SetFrameCount	Frame count	Frame count = 1 – ask for 1 frame
3	SetStartFrame	Start	Start=1 - start internal processing
	Wait ~1 s		After xx ms all the offset are set
4	SetStartframe	Start	Start=0 - stop internal process
5	SetDataMode	Mode	Mode = 18 - to get offset settings
6	SetStartFrame	Start	Start=1 - start sending frame with offsets
	Wait xx ms		All the offset are sent to DPU

2.2.8.3.2. Manual

Steps	Command	Parameters	Comment
1	SetLIAP1Offset	Channel_P1 Offset_P1	Channel_P1=0 Offset_P1=X
-	-	-	-
32	SetLIAP1Offset	Channel_P1 Offset_P1	Channel_P1=31 Offset_P1=X
33	SetLIAP2Offset	Channel_P2 Offset_P2	Channel_P2=0 Offset_P2=X
-	-	-	-
64	SetLIAP2Offset	Channel_P2 Offset_P2	Channel_P2=31 Offset_P2=X
-	-	-	-
-	-	-	-
288	SetLIAP9Offset	Channel_P9 Offset_P9	Channel_P9=31 Offset_P9=X

2.2.8.4. Photometer acquisition

2.2.8.4.1. Continuous

Steps	Command	Parameters	Comment
1	SetStartFrame	start	Start=0
2	SetDataMode	Mode	Mode = 00
3	SetFrameCount	frame	Frame=0
4	SetStartMode	start	Start=1

2.2.8.4.2. Frame burst

Steps	Command	Parameters	Comment
1	SetStartFrame	start	Start=0
2	SetDataMode	Mode	Mode = 00
3	SetFrameNber	frame	Frame=x (1 to 255 = number of frames)
4	SetStartFrame	start	Start=1

2.2.8.5. Spectrometer Configuration

Steps	Command	Parameters	Comment
1	SetSpectroBiasMode	SpectroBiasMode	Mode = FF
	Wait xx ms		After this time the system must be stable

2.2.8.6. Spectrometer offset setting

2.2.8.6.1. Automatic

Steps	Command	Parameters	Comment
1	SetStartFrame	start	Start=0 - stop/confirm stop sending frames
2	SetDataMode	Mode	Mode = 14 - automatic offset for spectro
3	SetStartFrame	start	Start=1- start internal processing
	Wait xx ms		After xx ms all the offset are set
4	SetStartFrame	start	Start=0 - stop internal process
5	SetDataMode	Mode	Mode = 1C - to get offset settings
6	SetStartFrame	start	Start=1- start sending frame with offsets
	Wait xx ms		All the offset are send to DPU

2.2.8.6.2. *Manual*

Steps	Command	Parameters	Comment
1	SetLIAS1Offset	Channel_S1 Offset_S1	Channel_S1=0 Offset_S1=X
-	-	-	-
24	SetLIAS1Offset	Channel_S1 Offset_S1	Channel_S1=23 Offset_S1=X
25	SetLIAS2Offset	Channel_S2 Offset_S2	Channel_S2=0 Offset_S2=X
-	-	-	-
48	SetLIAS2Offset	Channel_S2 Offset_S2	Channel_S2=23 Offset_S2=X
-	-	-	-
-	-	-	-
72	SetLIAS3Offset	Channel_S3 Offset_S3	Channel_S3=23 Offset_S3=X

2.2.8.7. **Spectrometer acquisition**

2.2.8.7.1. *Continuous*

Steps	Command	Parameters	Comment
1	SetStartFrame	start	Start=0
2	SetDataMode	Mode	Mode = 04
4	SetStartFrame	start	Start=1

2.2.9. MCU specific command list summary

2.2.9.1. Forewords

The information given in the present document is limited to an overview of the MCU commands and parameters. Complete commands documentation will be found in AD2.

2.2.9.2. Command and parameter mapping

The following table shows respectively the bit mapping for CID and PAR field of a low-level command for the MCU.

CID11	CID10 to CID9	CID8 to CID0	PAR15 to PAR0
R/ \bar{W}	- *	Command Code	Parameter(s)

*: not used –set to zero

2.2.9.3. General commands

Important notice:

These commands are only available in MCU initialisation phase before switching by means of the “SetBootRam” command from PROM to RAM program execution. Before executing this command it is mandatory to check the RAM integrity reported by the “BootStatusRegister” parameter. During this phase (INIT) other commands are not available.

Command Name	Argument(s)	Ranges List	Command verification	Execution Delay	CID
GetBootStatusRegister	BootStatusRegister	Discrete	NA	≤ 420 μs	820
Set/GetDownloadConfig	DownloadParam	Discrete	Get... cmd	≤ 420 μs	021/821
Set/GetDownloadWord*	DownloadWord	0 to FFFF hexa	Get... cmd	≤ 420 μs	022/822
GetDownLoadCounter*	DownloadCounter	0 to FFFF hexa	NA	≤ 420 μs	823
SetBootRam	SecondReset	Discrete	NA	≤ 420 μs	024

* for development phase only - not for flight

2.2.9.4. SMEC commands

2.2.9.4.1. Write/Read Commands

Command Name	Argument(s)	Ranges List	Command verification	Execution Delay	CID
Set/GetSEncoderPwr	SEncoderPwr	0...7 / 8	Get... cmd		040/840
Set/GetSLVDTPwr	SLVDTPwr	0/1	Get... cmd		041/841
Set/GetSLaunchLatch	SLaunchLatch	1/2	Get... cmd		043/843
Set/GetSLoopMode	SLoopMode	0...6	Get... cmd		044/844
Set/GetSTrajEndPosition	STrajEndPos	0 to 65535	Get... cmd		045/845
Set/GetSTrajStartPosition	STrajStartPos	0 to 65535	Get... cmd		046/846
Set/GetSScanFwdSpeed	SScanFwdSpeed	0 to 65535	Get... cmd		047/847
Set/GetSScanNumber	SScanN	0 to 65535	Get... cmd		048/848
Set/GetSTrajMode	STrajMode	0...4	Get... cmd		049/849
Set/GetSKp	SKp	2000 / 0 to FFFF hexa	Get... cmd		04A/84A
Set/GetSKd	SKd	2710 / 0 to FFFF hexa	Get... cmd		04B/84B
Set/GetSDerivFilter	SDerivFilt	xxxx / 0 to FFFF hexa	Get... cmd		04C/84C
Set/GetSKi	SKi	xxxx / 0 to FFFF hexa	Get... cmd		04D/84D
Set/GetSIntegrationLimit	SIntegrationLimit	0 to FFFF hexa	Get... cmd		04E/84E
Set/GetSIntegrationThreshold	SIntegrationThreshold	0 to FFFF hexa	Get... cmd		04F/84F
Set/GetSRateLimit	SRateLimit	300 / 0 to FFFF hexa	Get... cmd		051/851
Set/GetSDerivFilter2	SDerivFilter2	*			052/852
Set/GetSFeedFwdDiffGain	SFeedFwdDiffGain	*			053/853
Set/GetSFeedFwdGain	SFeedFwdGain	0 to FFFF hexa	Get... cmd		054/854
Set/GetSFeedFwdOffset	SFeedFwdOffset	8000 / 0 to FFFF hexa	Get... cmd		055/855
Set/GetSScanRevSpeed	ScanRevSpeed	5000 / 0 to FFFF hexa	Get... cmd		056/856
Set/GetEncoderSignal1Amp	EncoderSignal1Amp	0 to FFFF hexa	Get...		<u>057/857</u>
Set/GetEncoderSignal1Offset	EncoderSignal1Offset	0 to FFFF hexa	Get...		<u>058/858</u>
Set/GetEncoderSignal2Amp	EncoderSignal2Amp	0 to FFFF hexa	Get...		<u>059/859</u>
Set/GetEncoderSignal2Offset	EncoderSignal2Offset	0 to FFFF hexa	Get...		<u>05A/85A</u>
Set/GetEncoderSignal3Amp	EncoderSignal3Amp	0 to FFFF hexa	Get...		<u>05B/85B</u>
Set/GetEncoderSignal3Offset	EncoderSignal3Offset	0 to FFFF hexa	Get...		<u>05C/85C</u>
Spare Set/Get Command		*			<u>05D/85D</u>
Set/GetLVDTOffset	LVDTOffset	8000 / 0 to FFFF hexa	Get... cmd		05E/85E
Set/GetLVDTScale	LVDTScale	0 to FFFF hexa	Get... cmd		05F/85F
Set/GetSMotorBEMFGain	SMotorBEMFGain	0 to FFFF hexa	Get... cmd		090/890
Set/GetSMotorResistance	SMotorResistance	0 to FFFF hexa	Get... cmd		091/891
Set/GetSRateScaleFactor	SRateScaleFactor	0 to FFFF hexa	Get... cmd		093/893

2.2.9.4.2. *Read only commands*

Command Name	Argument(s)	Ranges List	Command verification	Execution Delay	CID
GetSMECStatus	SMECStatus	Discrete	NA		860
GetSEncoderIncrPosition	SEncodIncrPos	0 to FFFF hexa	NA		861
GetSEncoderSignal1	SEncoderfS1	0 to FFFF hexa	NA		862
GetSEncoderSignal2	SEncoderS2	0 to FFFF hexa	NA		863
GetSEncoderSignal3	SEncoderS3	0 to FFFF hexa	NA		864
GetLVDTPosition	LVDTPosition	0 to FFFF hexa	NA		865
GetLVDTAC	LVDTAC	0 to FFFF hexa	NA		866
GetLVDTDC	LVDTDC	0 to FFFF hexa	NA		867
GetTrajectoryPosition	TrajectoryPosition	0 to FFFF hexa	NA		868
GetSmecDACValue	SmecDACValue	0 to FFFF hexa	NA		869
GetEnclVDTPosDelta	EnclVDTPosDelta	0 to FFFF hexa	NA		86A
GetEncoderFinePosition	EncoderFinePosition	0 to FFFF hexa	NA		86B
GetMeanSpeed	MeanSpeed	0 to FFFF hexa	NA		<u>86E</u>
GetMeanPositionError	MeanPosError	0 to FFFF hexa	NA		<u>86F</u>
GetSMotorCurrent	SMotorCurrent	0 to FFFF hexa	NA		<u>870</u>
GetSMotorVoltage	SMotorCurrent	0 to FFFF hexa	NA		<u>871</u>
GetSBEMF	SBEMF	0 to FFFF hexa	NA		<u>892</u>

2.2.9.4.3. Write only commands

Command Name	Argument(s)	Ranges List	Command verification	Execution Delay	CID
---------------------	--------------------	------------------------	---------------------------------	----------------------------	------------

2.2.9.5. Chop commands

2.2.9.5.1. Write/Read commands

Command Name	Argument(s)	Ranges List	Command verification	Execution Delay	CID
Set/GetCSensorPwr	CSensorPwr	0/1	Get... cmd		0C0/8C0
SetChopLoopMode	ChopLoopMode	0...3	Get... cmd		0C2/8C2
Set/GetChopTargetPos	ChopTargetPos	0 to FFFF hexa	Get... cmd		0C3/8C3
Set/GetBSMMove	BSMMove	0...2	Get... cmd		0C6/8C6
Set/GetCOffset	COffset	0 to FFFF hexa	Get... cmd		0C7/8C7
Set/GetCKp	CKp	0 to FFFF hexa	Get... cmd		0C8/8C8
Set/GetCKd	CKd	0 to FFFF hexa	Get... cmd		0C9/8C9
Set/GetCKi	Cki	0 to FFFF hexa	Get... cmd		0CA/8CA
Set/GetCIntegThreshold	CIntegThreshold	0 to FFFF hexa	Get... cmd		0CB/8CB
Set/GetCIntegLimit	CIntegLimit	0 to FFFF hexa	Get... cmd		0CC/8CC
Set/GetCFeedFwdGain	CFeedFwdGain	0 to FFFF hexa	Get... cmd		0CD/8CD
Set/GetCFeedFwdDiffGain	CFeedFwdDiffGain	0 to FFFF hexa	Get... cmd		0CE/8CE
Set/GetDiffFilterTC1	DiffFilterTC1	6667 / 0 to FFFF hexa	Get... cmd		0CF/8CF
Set/GetDiffFilterTC2	DiffFilterTC2	8333 / 0 to FFFF hexa	Get... cmd		0D0/8D0
SetCRateLimit	CRateLimit	20 / 0 to FFFF hexa	Get... cmd		0D1/8D1
Set/GetCMotorBEMFGain	CMotorBEMFGain	0 to FFFF hexa	Get... cmd		0D2/8D2
Set/GetCMotorResistance	CMotorResistance	0 to FFFF hexa	Get... cmd		0D3/8D3
Set/GetCMotorInductance	CMotorInductance	0 to FFFF hexa	Get... cmd		0D4/8D4
Set/GetCRateScaleFactor	CRateScaleFactor	*	*		0D5/8D5
Set/GetCPosScaleFactor	CPosScaleFactor	0BEB / 0 to FFFF hexa	Get... cmd		0D6/8D6
Set/GetCBEMFRateFilter1	CBEMFRateFilter1	0 to FFFF hexa	Get... cmd		0D7/8D7
Set/GetCBEMFRateFilter2	CBEMFRateFilter2	0 to FFFF hexa	Get... cmd		0D8/8D8
Set/GetC2JCrossCoupling	C2JCrossCoupling	8000 / 0 to FFFF hexa	Get... cmd		0D9/8D9

2.2.9.5.2. Read only commands

Command Name	Argument(s)	Ranges List	Command verification	Execution Delay	CID
Get <u>B</u> SMStatus	<u>B</u> SMStatus	0 to FFFF hexa	NA		900
GetC <u>M</u> eanPosError	C <u>M</u> eanPosError	0 to FFFF hexa	NA		902
GetC <u>M</u> agResSignal	C <u>M</u> agResSignal	0 to FFFF hexa	NA		903
GetC <u>D</u> ACValue	C <u>D</u> ACValue	0 to FFFF hexa	NA		904
GetC <u>M</u> otorCurrent	C <u>M</u> otorCurrent	0 to FFFF hexa	NA		905
GetC <u>V</u> oltage	C <u>V</u> oltage	0 to FFFF hexa	NA		906

2.2.9.6. Jiggle commands

2.2.9.6.1. Write/Read commands

Command Name	Argument(s)	Ranges List	Command verification	Execution Delay	CID
Set/GetJSensorPwr	JSensorPwr	0/1	Get... cmd		140/940
SetJigLoopMode	JigLoopMode	0...3	NA		142/942
Set/GetJigTargetPos	JigTargetPos	0 to FFFF hexa	Get... cmd		143/943
Set/GetJigTargetPosition2	JigTargetPosition2	0 to FFFF hexa	Get... cmd		144/944
Set/GetJFeedFwdOffset	JFeedFwdOffset	*	*		147/947
Set/GetJKp	JKp	0 to FFFF hexa	Get... cmd		148/948
Set/GetJKd	JKd	0 to FFFF hexa	Get... cmd		149/949
Set/GetJKi	Jki	0 to FFFF hexa	Get... cmd		14A/94A
Set/GetJIntegThres	JIntegThres	0 to FFFF hexa	Get... cmd		14B/94B
Set/GetJIntegLimit	JIntegLimit	0 to FFFF hexa	Get... cmd		14C/94C
Set/GetJFeedFwdGain	JFeedFwdGain	0BEB / 0 to FFFF hexa	Get... cmd		14D/94D
Set/GetJFeedFwdDiffGain	JFeedFwdDiffGain	0 to FFF hexa	Get... cmd		14E/94E
Set/GetJDiffFilterTC1	JDiffFilterTC1	0 to FFFF hexa	Get... cmd		14F/94F
Set/GetJDiffFilterTC2	JDiffFilterTC2	0 to FFFF hexa	Get... cmd		150/950
Set/GetJRateLimit	JRateLimit	1000 / 0 to FFF hexa	Get... cmd		151/951
Set/GetJMotorBEMFGain	JMotorBEMFGain	0 to FFF hexa	Get... cmd		152/952
Set/GetJMotorResistance	JMotorResistance	0 to FFFF hexa	Get... cmd		153/953
Set/GetJMotorInductance	JMotorInductance	0 to FFFF hexa	Get... cmd		154/954
Set/GetJRateScaleFactor	JRateScaleFactor	*	*		155/955
Set/GetJPosScaleFactor	JPosScaleFactor	0BEB / 0 to FFFF hexa	Get... cmd		156/956
Set/GetJBEMFRateFilter1	JBEMFRateFilter1	0 to FFFF hexa	Get... cmd		157/957
Set/GetJBEMFRateFilter2	JBEMFRateFilter2	0 to FFFF hexa	Get... cmd		158/958
Set/GetJ2CCrossCoupling	J2CCrossCoupling	8000 / 0 to FFFF hexa	Get... cmd		159/959
Set/GetJ2CDCrossCoupling	J2CDCrossCoupling	*	*		15A/95A

2.2.9.6.2. Read only

Command Name	Argument(s)	Ranges List	Command verification	Execution Delay	CID
GetJMeanPosError	JMeanPosError	0 to FFFF hexa	NA		982
GetJMagResSignal	JMagResSignal	0 to FFFF hexa	NA		983
GetJDACValue	JDACValue	0 to FFFF hexa	NA		984
GetJMotorCurrent	JMotorCurrent	0 to FFFF hexa	NA		985
GetJVoltage	JVoltage	0 to FFFF hexa	NA		986

2.2.9.7. Telemetry and trace configuration commands

Command Name	Argument(s)	Ranges List	Command verification	Execution Delay	CID
Set/GetTP10SampFreq	TP10SampFreq	0 to xxxx hexa	Get... cmd		1C0/9C0
Set/GetFrameStart	FrameStart	0 / 1	Get... cmd		1C1/9C1
Set/GetTP12SampFreq	TP12SampFreq	0 to xxxx hexa	Get... cmd		1C2/9C2
Set/GetFrameNumber	FrameNumber	0 to FFFF	Get... cmd		1C3/8C3
Set/GetTP14SampFreq	TP14SampFreq	0 to xxxx hexa	Get... cmd		1C4/9C4
Set/GetTP15SampFreq	TP15SampFreq	0 to xxxx hexa	Get... cmd		1C5/9C5
Set/GetPack10Param5	Pack10Param5	0 to FFFF hexa	Get... cmd		1C6/9C6
Set/GetPack10Param1 ... Set/Get Pack10Param4	Pack10Param1 to Pack10Param4	0 to FFFF hexa	Get... cmd		1C7/9C7 to 1CA/9CA
Set/GetPack12Param1 ... Set/Get Pack12Param6	Pack12Param1 to Pack12Param6	0 to FFFF hexa	Get... cmd		1CB/9CB to 1D0/9D0
Set/GetPack14Param1 ... Set/Get Pack14Param14	Pack14Param1 to Pack14Param14	0 to FFFF hexa	Get... cmd		1D1/9D1 to 1DE/9DE
Set/GetTelemetryStatus	TelemetryStatus	0...3	Get... cmd		1DF/9DF

2.2.9.8. HK and miscellaneous commands

Command Name	Argument(s)	Ranges List	Command verification	Execution Delay	CID
GetP5V	P5V	0 to FFFF hexa	NA		9E0
GetP13V	P13V	0 to FFFF hexa	NA		9E1
GetM13V	M13V	0 to FFFF hexa	NA		9E2
GetP15V	P15V	0 to FFFF hexa	NA		9E3
GetM15V	M15V	0 to FFFF hexa	NA		9E4
GetMACTemp	MACTemp	0 to FFFF hexa	NA		9E5
GetSMECTemp	SMECTemp	0 to FFFF hexa	NA		9E6
GetBSMTemp	BSMTemp	0 to FFFF hexa	NA		9E7
GetErrorCode	ErrorCode	Discrete	NA		9E9
GetSchedCntLSW	SchedCntLSW	0 to FFFF hexa	NA		9EA
GetSchedCntMSW	SchedCntMSW	0 to FFFF hexa	NA		9EB
SetWarmReset	WarmReset	*	*		1EC

2.2.10. MCU command/parameter description

2.2.10.1. General commands

CID	Command CIDnic	Action and Parameter specification
820h	GetBootStatusRegister	<p>Reply parameter: Boot Status Register</p> <p>bit 0: 1 when RAM integrity done 0 otherwise</p> <p>bit 1: 1 when test program ram failed</p> <p>bit 2: 1 when test data ram failed</p> <p>bit 3: 1 when copy from PROM to RAM program is in progress</p> <p>bit 4: <i>BOOT_MODE</i> : 0 when mode is copy from PROM</p> <p>bit 5: 1 when download from DPU to RAM program is in progress (not in flight)</p> <p>bit 6: 1 when upload from RAM program to DPU is in progress (not in flight)</p> <p><i>bit 7 : Reserved</i></p> <p><i>bits 8-15: RAM_PROG_CHECKSUM</i></p> <p><i>Checksum computed on all the RAM program</i></p> <p><i>The checksum is computed after the RAM integrity to check the null value and then each time that a download or a copy to PROM is complete (from DPU or from PROM).</i></p>
021h 821h	SetDownloadConfig GetDownloadConfig	<p>Configure the download of program</p> <p>Read: the download configuration. In flight the only possibility is the copy from PROM to RAM</p>
022h 822h	SetDownloadWord GetDownloadWord	<p>Download a 16 bit word to program memory</p> <p>Read the last 16 bit word to be downloaded program memory</p>
823h	GetDownLoadCounter*	Read the downloaded program counter
027h	SetBootRam	Launch the second reset and boot on RAM

2.2.10.2. SMEC commands

CID	Command Name	Action and Parameter specification
040h 840h	Set/GetSEncoderPwr	Powers the optical encoder led at various 8 illumination levels (3 bits): 000 = not led illumination – 111 = max 5V illumination Other value: “8” allows to init the offset value of encoder on actual signal and return to previous setting.
041h 841h	Set/GetSLVDTPwr	Power on/off the LVDT oscillator (Boolean): 0: the LVDT oscillator is inhibited. 1: the LVDT oscillator is activated Other value: no action (remains at same state).
043h 843h	Set/GetSLaunchLatch	Engage/disengage SMEC Launch Latch: 1:engage 2:disengage Other value: no action. The command parameter is automatically reset after being taking into account
044h 844h	Set/GetSLoopMode	Open or close loop mode selection: 0: open loop, DAC imposed to steady value (frozen) 1: closed loop on encoder signals 0&1 (sine 0° and 120° encoder ADC sig) 4: closed loop on LVDT raw for step control using direct LVDT ADC value (without linearity compensation) 6: open loop with feedforward control + backemf
045h 845h	Set/GetSTrajEndPosition	Specifies the position to reach in both scan or step mode Unit:1 μm (0:65536 unsigned number) 0 is set after program initialisation and motion initialisation. The mechanical limit is the absolute reference for the motion (typically at – 8mm from OPD and 0 LVDT)
046h 846h	Set/GetSTrajStartPosition	Specifies the initial position for an automatic scan: the scan shall evolve N times from Start to End Positions Same unit as TrajEnd Position
047h 847h	Set/GetSScanFwdSpeed	Specifies the scan speed in positive direct way 0:65535: 0.1 $\mu\text{m/s}$ unit. (0x90471388 command set speed at 500 $\mu\text{m/s}$). The speed is limited to 2mm/s – Should be used in closed loop mode
048h 848h	Set/GetSScanNumber	0-65535: number of scan value Default value: 0 The scan number is decremented each time the ramp sign changes
049h 849h	Set/GetSTrajMode	Specifies the type of trajectory: 0: trajectory generation is stopped and remains steady. Allows start/stop trajectory computation 1: move the SMEC to end trajectory in a filtered step mode 2: scan mode for N times at programmed direct and reverse speed 3: cancelled/not used. 4: initialisation – reset encoder counter to “start trajectory value”
04Ah 84Ah	Set/GetSKp	Proportional gain of the digital PID controller To be tuned after Kd only because of servo loop constraints
04Bh 84Bh	Set/GetSKd	Derivative Gain of the digital PID controller
04Ch 84Ch	Set/GetSDerivFilter	Sets the filtering time constant to calculate the derivative term. See note xx
04Dh 84Dh	Set/GetSKi	Integral gain of the digital PID controller Unit: TBD Default:TBD

04Eh 84Eh	Set/GetSIntegrationLimit	Loads/Reads the integration saturation for the integral compensation of the servo
04Fh 84Fh	Set/GetSIntegrationThreshold	Loads/Reads the integration threshold for the integral compensation of the servo (typical value: 0)
051h 851h	Set/GetSRateLimit	Slew rate limiter to reduce encoder count loss during step changes. Default: 300 (0.5 s transients) 20 is for high limitation / 65535 for no limitation
052h 852h	Set/GetSDerivFilter2	Command as no effect
053h 853h	Set/GetSFeedFwdDiffGain	Command as no effect
054h 854h	Set/GetSFeedFwdGain	Specifies the ratio between EndTrajectory and motor current for open loop operation Unit: (delta current ADU) / (delta position - μm) * 1000 Default: 30518
055h 855h	Set/GetSFeedFwdOffset	Specify the offset current to be applied when mechanism is at 0 position. Unit: DAC unit Default:0 Use in case of gravity
056h 856h	Set/GetSScanRevSpeed	Specifies trajectory speed for flyback (reverse speed) Unit: 0.1 $\mu\text{m/s}$ Default: 5000 Limited to 2mm/s
057h 857h	Set/GetEncoderSignal1Amp	Read/set the computed encoder sine amplitude for normalisation of the arcsine computation (fine interpolated position) After a few periods of the sine signal during a scan, the amplitude is automatically computed by the software
058h 858h	Set/GetEncoderSignal1Offset	Get: reads the computed offset Set: Adjust the optical encoder signal 1 mean value for zero crossing and position computation
059h 859h	Set/GetEncoderSignal2Amp	Idem for signal 2
05Ah 85Ah	Set/GetEncoderSignal2Offset	Idem for signal 2
05Bh 85Bh	Set/GetEncoderSignal3Amp	Idem for signal 3
05Ch 85Ch	Set/GetEncoderSignal3Offset	Idem for signal 3
05Dh 85Dh	Set/GetLVDTLUT	Command has no effect
05Eh 85Eh	Set/GetLVDTOffset	The LVDT Offset is the value (in μm) starting from mechanical limit of the LVDT 0V position. Unit: microns Default: 8000 (8 mm)
05Fh 85Fh	Set/GetLVDTScale	Set the scale factor between ADC value of LVDT DC signal and actual position Unit: 1 μm

The following commands are get commands, i.e. read-only commands for the SMEC computed parameters.

CID	Command Name	Action and Parameter specification
860h	GetSMECStatus	<p>Reads the SMEC Status Register.</p> <p>The status register aims to indicate to DPU external actions to be performed in relation with some events related to the SMEC axis. This Status Register can only be read and no bit can be cleared since the word is refreshed by the chipset.</p> <p>The status register does not provide precise information on parameter values since individual get commands are available (example: the state of digital I/O shall be read out by individual get LVDT Power, get encoder power, get latch command, etc...)</p> <p>Bit 0: FATAL ERROR This bit is a summary for DPU about the fact that SMEC mechanics is in fatal error state due to closed loop malfunction and put at safe configuration. DPU must re-launch the entire commanding scenario.</p> <p>Bit 1 - LVDT positive (1) or negative (0). Allows the detection of LVDT 0V home position on transient of this bit</p> <p>Bit 2 - SMEC Initialised (1) not initialised (0) or has become lost (0). The encoder count is lost when the servo error exceeds tolerated value or when in open loop.</p> <p>Bit 3 - Scan up/down indicator: increasing steps (0) decreasing steps (1)</p> <p>Bits 4-15 - scan number same as the 16 bit parameter reduced on 12bits</p>
861h	GetSEncoderIncrPosition	<p>Read the incremental count on 0Xing of the encoder sine signal to give encoder crude position.</p> <p>Unit: 1μm (i.e. every zero crossing of a 2μm sine period encoder signal)</p>
862h	GetSEncoderSignal1	<p>Read the optical encoder sine signal 1 (0°)</p> <p>Unit: 16-bit ADU</p>
863h	GetSEncoderSignal2	<p>Read the optical encoder sine signal 2 (120°)</p> <p>Unit: 16-bit ADU</p>
864h	GetSEncoderSignal3	<p>Read the optical encoder sine signal 3 (240°)</p> <p>Unit : 16-bit ADU</p> <p>Signal not used for position counting</p>
865h	GetLVDTPosition	<p>Reads the computed /filtered LVDT position</p> <p>Unit: 1μm</p>
866h	GetLVDTAC	<p>Reads the AC decoupled LVDT signal</p> <p>Unit: 16-bit ADU</p>
867h	GetLVDTDC	<p>Read the DC LVDT signal</p> <p>Unit: 16-bit ADU</p>
868h	GetTrajectoryPosition	<p>Returns the current position generated by the trajectory</p> <p>Unit: 1μm</p>
869h	GetSmecDACValue	<p>Returns the value of the DAC value which drives the motor</p> <p>0 mA = 0x8000</p>
86Ah	GetEncLVDTPosDelta	<p>Returns the encoder count value when the LVDT crosses 0.</p> <p>Unit: 1μm count</p>
86Bh	GetEncoderFinePosition	<p>Returns the fine arcsine interpolated position of the encoder sine signal.</p> <p>Unit: 1nm</p>
86Eh	GetMeanSpeed	<p>Actual scan mean measured speed</p> <p>Allows to verify the velocity scan error</p> <p>Unit: 0.1 μm/sec - digitally filtered (20Hz 1st order)</p>

86Fh	GetMeanPositionError	Mean position error of the servo (delta between trajectory and sensor position) Unit: 10nm
870h	GetSMotorCurrent	Returns the measured motor current value. Unit : 1 ADC unit; 0x8000=0mA; Full scale 0xFFFF=100mA
871h	GetSMotorVoltage	Returns the motor voltage value. Unit 1 ADC unit - 0xFFFF = 0.5 Volts, 0x8000= 0 Volt. The motor voltage is (Rmot*I +Backemf). (Back emf is proportional to motor speed about 17V/ms-1) Example: motor resistance: 5 Ohm, current=100mA, voltage=0.5 Volts

Additional set/get parameters for fine tuning of back emf

CID	Command Name	Action and Parameter specification
090h 890h	Set/GetMotorBEMFGain	Gain applied fro the feedback of the back EMF damping control. To be tuned from 0 with small increases until open loop position, well damped
091h 891h	Set/GetMotorResistance	Motor + harness resistance used to substract RI value from motor voltage Unit: motor voltage / motor current ratio * 10000
892h	GetMotorBEMF	Read the motor BEMF voltage
093h 893h	Set/GetRateScaleFactor	Rate limitation to be applied on motor back EMF to avoid fast transients

2.2.10.3. CHOP commands

CID	Command Name	Action and Parameter specification
0C0h 8C0h	Set/GetCSensorPwr	On/Off (0 /1) : Power on magnetoresistive sensor Of the chopper axis
0C2h 8C2h	SetChopLoopMode	Open or close loop mode selection Parameter definition: 0 = Loop opened : DAC steady 1 = Loop closed on magnetoresistive sensor (prime control scheme) 3 = no sensor (open loop operation using backemf)
0C3h 8C3h	Set/GetChopTargetPos	Set the position step to be reached (also called X position). Unit: 1 ADU
0C4h 8C4h	Set/GetChopPosition2	For Chopper tuning: allow defining a starting position when using BSM Move test (see command C6). Unit: ADC Unit
0C6h 8C6h	Set/GetBSMMove	0: Chopper and Jiggle are independent and move on free run mode (i.e. the position reference is taken into account immediately) 1: Both axis ordered to move synchronously on this order 2: Test pattern on both axis (TBC)
0C7h 8C7h	Set/CFFOFFSET CFFOFFSET	Allow to add a DAC offset on chopper motor current to move the motor until the sensor ADC value is centered for closed loop control. Same unit as DAC unit (0x8000 is 0mA offset). DAC = (TARGET-CFF_OFFSET)*FFGAIN/3051.8
0C8h 8C8h	Set/GetCKp	Proportional gain of the digital PID controller
0C9h 8C9h	Set/GetCKd	Derivative Gain of the digital PID controller (also called rate feedback gain)
0CAh 8CAh	Set/GetCKi	Integral gain of the digital PID controller
0CBh 8CBh	Set/GetCIntegThreshold	Integration threshold (dead zone on servo error before starting integration) 0xFFFF = no gap, no threshold
0CCh 8CCh	Set/GetCIntegLimit	Integration limitation for the integral compensation of the servo Allow to saturate the integral effect to limit current
0CDh 8CDh	Set/GetCFeedFwdGain	Feed forward gain of open loop control. Unit: DAC value = FFGain/3051*(TargetPosition-CFF_OFFSET) . With default = 3051 (0x0BEB) the DAC value shall be equal to TargetPosition.(with small truncature)
0CEh 8CEh	Set/GetCFeedFwdDiffG	Derivative gain on the Feed forward of open loop. Default value: 0
0CFh 8CFh	Set/GetDiffFilterTC1	Differential filter for PID derivative control. Unit: 10 ⁻⁴ *coeff Default: 6667. Common with bemf control may be changed if no sensor mode. Tune the derivative filtering cut off frequency
0D0h 8D0h	Set/GetDiffFilterTC2	Differential filter for PID control. Unit: 10 ⁻¹ *coeff. Default: 8333 Common with bemf control may be changed if no sensor mode

0D1h 8D1h	SetCRateLimit	Slew rate limiter to reduce power dissipation during step changes. Unit: 10 ⁵ degrees/0.4msec Default: 20
0D2h 8D2h	Set/GetCMotorBEMFGain	Motor back emf constant, i.e. the feedback gain applied on the computed backemf damping. Default: 0
0D3h 8D3h	Set/GetCMotorResistance	Motor + harness resistance used to subtract RI value from motor voltage. BEMF = MotorVoltage- MotorCurrent * MotorResistance * 0.0001 Default: 0
0D4h 8D4h	Set/GetCMotorInductance	Motor + harness inductance compensation Default: 0 (Normally not used)
0D5h 8D5h	Set/GetCRateScaleFactor	Command is not implemented
0D6h 8D6h	Set/GetCPosScaleFactor	Scale factor between reference position and estimated mechanical force. Had the same function as Feed forward gain so the command is still declared but replaced in the code by a unique FeedForwardGain. Default: 3051
0D7h 8D7h	<u>Set/GetCBEMFRateFilter1</u>	Digital filter coeff 1 for rate filtering of the BACK EMF effect Default: conversion of 847.458(*0.000001)
0D8h 8D8h	<u>Set/GetCBEMFRateFilter2</u>	Digital filter coeff 2 for rate filtering of the BACK EMF effect Default: conversion of 0.69491 (*0.0001)
0D9h 8D9h	Set/GetC2JCrosscoupling	Cross coupling constant between chopper and jiggle: JIGDAC=(CHOPTRAJ-0x8000)*(C2JCROSSCOUPLING-0x8000)*10e-8 (*32765) Default value: 0x8000 = 0mA static compensation
0DAh	Set/GetC2JDCrosscoupling	Derivative of cross coupling Command declared but not implemented because not used.

The following commands are **read only** for HK and telemetry data.

CID	Command Name	Action and Parameter specification
900h	GetChopStatus	Reads the Chopper axis Activity Status Register. This Status Register can only be read and no bit can be cleared since the word is refreshed by the chipset.
902h	GetCMeanPosError	Returns the mean servo error between target and MR sensor
903h	GetCMagResSignal	Returns the sensor measurement from ADC
904h	GetCDACValue	Returns the DAC value sent to chopper motor
905h	GetCMotorCurrent	Returns the motor current value from ADC
906h	GetCBEMF	Returns the motor voltage signal value from ADC

2.2.10.4. JIGGLE commands

CID	Command Name	Action and Parameter specification
140h 940h	Set/GetJSensorPwr	Power on magneto resistive sensor of the jiggle axis 0: Off 1: On
142h 942h	Set/GetJigLoopMode	Open or close loop mode selection <u>Parameter definition:</u> 0 = Loop opened : DAC steady 1 = Loop closed on magneto resistive sensor 2: not used 3 = no sensor (open loop operation using backemf)
143h 9C3h	Set/GetJigTargetPosition	Set the position step to be reached. Unit: in closed loop: MR sensor ADC Unit to reach (1 ADU) in open loop : DAC desired value (1ADU)
144h 9C4h	Set/getJigTargetPosition2	For Jiggle tuning: allow defining a starting position when using BSM Move test (see command C6). Unit: ADC Unit
147h 947h	Set/GetJFFOFFSET	Should allow to add an offset on DAC Command declared but not implemented in algorithm
148h 948h	Set/GetJKp	Proportional gain of the digital PID controller
149h 949h	Set/GetJKd	Derivative Gain of the digital PID controller (also called rate feedback gain)
14Ah 94Ah	Set/GetJKi	Integral gain of the digital PID controller
14Bh 94Bh	Set/GetJIntegrationThreshold	Integration threshold (dead zone on servo error before starting integration). 0xFFFF = no gap, no threshold
14Ch 94Ch	Set/GetJIntegratorLimit	Integration limitation for the integral compensation of the servo
14Dh 94Dh	Set/GetJFeedForwardGain	Feed forward gain of open loop control. Unit: DAC value= FFGain/3051*(TargetPosition) . With Default value =3051 (0xBEB), the DAC value shall be equal to TargetPosition. (with small truncature).
14Eh 94Eh	Set/GetJFeedForwardDiffGain	Derivative gain on the Feed forward of open loop. Default value: 0
14Fh 94Fh	Set/GetJDifffiltc1	Differential filter for PID derivative control. Unit: 10 ⁻⁴ *coeff. Common with bemf control may be changed if no sensor mode
150h 950h	Set/GetJDifffiltc2	Differential filter for PID control. Unit: 10 ⁻¹ *coeff. Common with bemf control may be changed if no sensor mode
151h 951h	Set/GetJRateLimit	Slew rate limiter to reduce power dissipation during step changes. Unit: 10 ⁵ degrees/0.4msec.Default: 1000°/sec
152h 952h	Set/GetJMotorBEMFGain	Motor back emf constant, i.e. the feedback gain applied on the computed backemf damping. Default: 0
153h 953h	Set/GetJMotor resistance	Motor + harness resistance used to subtract RI value from motor voltage. BEMF= MotorVoltage- MotorCurrent*MotorResistance*0.0001. Default: 0
154h 954h	Set/GetJMotor inductance	Motor + harness inductance (normally not used)

CID	Command Name	Action and Parameter specification
155h 955h	Set/GetJRateScalefactor	Command declared for possible future use but not implemented
156h 956h	Set/GetJigPositionScalefactor	Scale factor between reference position and estimated mechanical force. Had the same function as Feed forward gain so the command is still declared but replaced in the code by an unique FeedForwardGain. Default:3051
157h 957h	Set/GetJBemfRateFilter1	Digital filter coeff 1 for rate filtering of the BACK EMF effect Default: conversion of 847.458(*0.000001)
158h 958h	Set/GetJBemfRateFilter2	Digital filter coeff 2 for rate filtering of the BACK EMF effect Default: conversion of 0.69491 (*0.0001)
159h 959h	Set/GetJ2CCrossCoupling	Cross coupling constant between jiggle and chopper Default value: 0mA i.e. 0x8000
15Ah 95Ah	Set/GetJ2CDCrosscoupling	Derivative of cross coupling Command declared but not implemented because not used.

The following commands are **read only** for HK and telemetry data.

CID	Command Name	Action and Parameter specification
982h	GetJMeanPositionError	Returns the servo error between target and MR sensor
983h	GetJMagnetoresistiveSignal	Returns the sensor measurement from ADC
984h	GetJDACValue	Returns the DAC value sent to chopper motor
985h	GetJMotorCurrent	Returns the motor current value from ADC
986h	GetJVoltage	Returns the motor voltage signal value from ADC

2.2.10.5. Telemetry commands

CID	Command Name	Action and Parameter specification
1C0h 9C0h	Set/GetTP10SampFreq	Set the sampling rate of the telemetry packet#10. (SMEC Science data) Unit= number of scheduler cycle (420us) 0 means this packet will not be sent – other value means it will be sent when FrameStart is activated
1C1h 9C1h	Set/GetFrameStart	0 means no packets are being sent or stop the telemetry packets being sent. 1 means start sending the packets with a definite value for the sampling rate (as defined above) at the rate defined – interleave packets as required.
1C2h 9C2h	Set/GetTP12SampFreq	Set the sampling rate of the telemetry packet#12 (BSM Science data) 0 means this packet will not be sent – other value means it will be sent when FrameStart is activated
1C3h 9C3h	Set/GetFrameNumber	FFFF = continuous when StartFrame is activated Other value gives number of frames to be sent following the issuing of the FrameStart(1) command. Once this number of frames has been sent the FrameStart is set to 0
1C4h 9C4h	Set/GetTP14SampFreq	Set the sampling rate of the telemetry packet#14 (Engineering data) 0 means this packet will not be sent – other value means it will be sent when FrameStart is activated
1C5h 9C5h	Set/GetTP15SampFreq	Set the sampling rate of the telemetry packet#15 (Test data) 0 means this packet will not be sent – other value means it will be sent when FrameStart is activated
1C7h 9C7h	Set/GetPack10Param1	Programmable value. Unit: address in the PTA of the desired parameter. Default value: coarse encoder position (1 μ m counts)
1C8h 9C8h	Set/GetPack10Param2	Programmable Default value: fine encoder position (result of arcsin)
1C9h 9C9h	Set/GetPack10Param3	Programmable Default value: LVDT Position
1CAh 9CAh	Set/GetPack10Param4	Programmable Default value: Commanded current to the motor (value to DAC)
1C6h 9C6h	Set/GetPack10Param5	Programmable Default value : motor back emf (motor voltage-RI)
1CBh 9CBh	Set/GetPack12Param1	Programmable Default value: Chop. position (MR signal from ADC)
1CCh 9CCh	Set/GetPack12Param2	Programmable Default value : Chopper motor current (value to DAC)
1CDh 9CDh	Set/GetPack12Param3	Programmable Default value : Chopper motor voltage (from ADC)
1CEh 9CEh	Set/GetPack12Param4	Programmable Default value : Jiggle position (MRS signal from ADC)
1CFh 9CFh	Set/GetPack12Param5	Programmable Default value : Jiggle motor commanded current (value to DAC)
1D0h 9D0h	Set/GetPack12Param6	Programmable Default value : Jiggle motor voltage (from ADC)
1D1h 9D1h	Set/GetPack14Param1	Programmable Default value : SMEC encoder count
1D2h	Set/GetPack14Param2	Programmable

9D2h		Default value : SMEC encoder signal 1 (from ADC)
1D3h 9D3h	Set/GetPack14Param3	Programmable Default value : SMEC encoder signal 2 (from ADC)
1D4h 9D4h	Set/GetPack14Param4	Programmable Default value : SMEC encoder signal 3 (from ADC)
1D5h 9D5h	Set/GetPack14Param5	Programmable Default value : SMEC LVDT AC signal (from ADC)
1D6h 9D6h	Set/GetPack14Param6	Programmable Default value : SMEC LVDT DC signal (from ADC)
1D7h 9D7h	Set/GetPack14Param7	Programmable Default value : SMEC motor current (from ADC)
1D8h 9D8h	Set/GetPack14Param8	Programmable Default value : SMEC motor voltage (from ADC)
1D9h 9D9h	Set/GetPack14Param9	Programmable Default value: Chop. MR Signal (from ADC)
1DAh 9DAh	Set/GetPack14Param10	Programmable Default value: Chop. motor current signal (from ADC)
1DBh 9DBh	Set/GetPack14Param11	Programmable Default value: Chop. Motor voltage (from ADC)
1DCh 9DCh	Set/GetPack14Param12	Programmable Default value: Jiggle MR signal(from ADC)
1DDh 9DDh	Set/GetPack14Param13	Programmable Default value: Jiggle motor current signal (from ADC)
1DEh 9DEh	Set/GetPack14Param14	Programmable Default value: Jiggle motor voltage (from ADC)
1DFh 9DFh	Set/GetTelemetryStatus	Status of telemetry: B0=1 : Packet10 on B2=1 : Packet12 on B4=1 : Packet14 on B5=1 : Packet15 on

2.2.10.6. HK and miscellaneous commands

CID	Command Name	Action and Parameter specification
9E0h	<u>GetMACTemp</u>	Read the MAC temperature probe
9E1h	<u>GetSMECTemp</u>	Read the SMEC temperature probe
9E2h	<u>GetBSMTemp</u>	Read the BSM temperature probe
9E3h	<u>GetP15V</u>	Read the + 15V power supply voltage
9E4h	<u>GetM15V</u>	Read the -15V power supply voltage
9E5h	<u>GetP13V</u>	Read the + 13V power supply voltage
9E6h	<u>GetM13V</u>	Read the -13V power supply voltage
9E7h	<u>GetP5V</u>	Read the +5V power supply voltage
9E9h	<u>GetErrorCode</u>	Not functional – see SMEC status instead.
9EAh	<u>GetSchedCntLSW</u>	Read MCU scheduler cycle counter (Least Sig).
9EBh	<u>GetSchedCntMSW</u>	Read MCU scheduler cycle counter (Most Sig).
1ECh	<u>SetWarmReset</u>	Command not implemented.

2.2.11. Main transfer functions

2.2.11.1. SMEC motor current

The motor current is set by a DAC whose transfer function is given by the following equation:

$$\text{DAC} = \text{ffoffset} + \text{feedforward} - \text{backemf_feedback} + \text{PID} *$$

*: in closed loop mode only

DAC unit: 65535= 100mA; 32768=0mA; 0= -100mA

- **ffoffset= FFOFFSET** (Note: the ffoffset change is limited in slew rate by the parameter SMEC_BEMF_RATE)
- **feedforward = TargetPosition*FFGAIN * 32768 * 10⁻⁹**
- **backemf_feedback = (((Motor_Voltage_ADC - 0x8000) - (Motor_Current_ADC - 0x8000) * Motor_Resistance * 0.0001) * SMEC_BEMF_CONSTANT * 0.000001) * 32767 + 32767**
- **PID = positionerror(t) * Kp + ((positionerror(t)-positionerror(t-1)) + Kdeffect(t-1)* SDERIVFILTER * 0.0001) * Kd * 0.00001 + Ki * 0.000001 * sum(position(t-i))**

with

- **Positionerror = TargetPosition-SensorPosition (micron)**

- **sum(position(t-i))** is the sum of all samples of position errors limited by **SINTEGRATION_LIMIT**
- The sum is produced only if the sum exceeds **SINTEGRATION_THRESHOLD**.

2.2.11.2. Encoder signal

The normalized sine amplitude (get a -1 +1 signal range) is computed as follow:

$$\text{Normalized sine} = (\text{encoder sine signal} - \text{sine offset}) / \text{sine amplitude}$$

The count is done on each 0 crossing of the sine signal 1. To start counting, the user must program an offset in order to get a centered signal around 0 to allow zero crossing detection. Then the offset and amplitude is automatically re-calculated during the counting to adjust new values depending on signal 1 and 2 offset and amplitude evolutions.

The up count or down count is decided depending on signal2 sign. When the loop is closed, the encoder counter is automatically reset to trajectory position value (so the servo error is zero) to avoid transient currents with the risk of shocks on mechanism and loss of encoder counts.

Then a 500 points arcsin LUT produces a fine position (nm unit) on the normalized sine signal1

2.2.11.3. SMEC LVDT position

The position of the LVDT (in microns) is given by the following equation

$$\text{LVDT position} = (\text{LVDT ADC} - 0x8000) * \text{LVDTSCALE} * 0.00002 + \text{LVDT_OFFSET}$$

LVDT scale to be programmed is:

$$\text{delta} (\mu\text{m encoder counts}) / \text{delta}(\text{LVDT ADU} * 50000) \text{ in its linear range.}$$

2.2.11.4. BSM motor currents

The motor current is set by a DAC whose transfer function is given by the following equation (for each chopper/jiggle axis):

:

$$\text{DAC} = \text{feedforward} - \text{backemf_feedback} + \text{PID} * + \text{crosscoupling}$$

*: in closed loop mode only

- **crosscoupling (chopper) = (J2CCROSSCOUPLING - 0x8000) * 0.00000001 * (jigtraj - 0x8000)**
- **feedforward (chopper) = (choptraj - CFF_OFFSET) * CFFGAIN * 32768 * 10⁻⁸**
feedforward (jiggle) = (jigtraj - 0x8000) * JFFGAIN * 32768 * 10⁻⁸
- **backemf **: = (((Motor_Voltage_ADC - 0x8000) - (Motor_Current_ADC-0x8000) * Motor_Resistance *0.0001) * CHOP_BEMF_GAIN * 0.0000001) * 32767 + 32767**
 (Motor inductance not to be used and set to 0)

** filtered with digital filter (CBEMF_RATE_FILT1 and CBEMF_RATE_FILT2 coefficients)

- **PID = positionerror(t) * Kp + ((positionerror(t)-positionerror(t-1))* CDIFF_FILTER_TC2*0.1 + Kdeffect(t-1)* CDIFF_FILTER_TC1*0.0001)*Kd*0.0000000001 + Ki *0.000001*sum(position(t-i))**

with

- **positionerror=TargetPosition-SensorPosition** in sensor ADC unit
- **sum(position(t-i))** is the sum of all samples of positionerrors limited by **INTEGRATION_LIMIT** - the sum is produced only if the sum exceeds **INTEGRATION_THRESHOLD**.

2.2.12. Commanding scenarios

Important Note:

Some parameter values indicated in this section of the document are not applicable since actual values to be programmed shall depend on both models and environment conditions. The scenarios are given as example of use to illustrate typical operation of the MCU.

2.2.12.1. Scenario sequence

The scenarios must follow the specified sequence. Some preliminary set up of parameters is compulsory before any proper operation of the mechanism control. Some parameters are critical for change (PID for example). Other use of commands outside the scenario scheme is under the responsibility of the user.

Refer to each scenario description in this document (next chapters) for precise definition.

Scenario name	Operation done in the scenario	To be run compulsory after scenario:
Power on and first boot scenario	Check the RAM memory	Switch off or reset scenario
Boot on ram	Download application program to RAM and initialise default values Check in the voltages and temperatures of electronics.	Power on scenario
BSM set up scenario for closed loop	Configure BSM axis control and scales.	Boot on RAM
BSM set up for open loop	Close the loop on magneto resistive sensors of both axis	BSM set up scenario
BSM science operation: Independent control of axis	Move the 2 axis independently In either open or closed loop	BSM Closed loop on MR sensor scenario or BSM setup scenario for open loop
BSM science operation: Synchronous control of axis	Move the 2 axis synchronously In either open or closed loop	BSM Closed loop on MR sensor scenario or BSM setup scenario for open loop
SMEC LATCH OFF scenario	Apply a negative current on motor, unlatch and then restore null current	Boot on RAM
SMEC set up scenario	Configure SMEC control parameters (PID), encoder signal levels, LVDT scale.	Boot on RAM
Closed loop on encoder scenario	Close the loop on the encoder before science operation	SMEC set up scenario
Closed loop on LVDT scenario	Close the loop on the LVDT before science operation	SMEC set up scenario
Science operation in scan mode scenario	Use of the scan for science	Closed loop on encoder or Closed loop on LVDT
Science in step mode scenario	Use of the step mode for science	Closed loop on encoder or Closed loop on LVDT
Latch in scenario	Scenario to latch the SMEC	Science operation scenarios
Telemetry scenario	Set up and use of the fast link telemetry.	Whatever scenario after boot on RAM

Shutdown scenario	Scenario to reset all values before switch off.	Science operation scenarios
--------------------------	---	-----------------------------

2.2.12.2. Power on and MCU first boot scenario

ACTION	Command	Expected return	COMMAND (HEX)
BOOT SCENARIO	Subsystem Reset		90010005
	Wait 1 sec		
	Subsystem reset release		90010007
	Read BootStatusRegister	should be 88200001	98200000
	Reset CmdIfStat		90010003
	Release reset of CmdIfstat		90010007
BOOT ON RAM	SetDownLoadConf	Download to ram from prom	9021C000
	Wait 5sec		
	SetBootRam, 1	Start DSP program in RAM	90240001
CHECK HK	Get5V	Read 5V : should be around 9B26	99E00000
	Getp14V	Read 14V : should be around 96XX	99E10000
	Getm14V	Read -14V : should be around 69XX	99E20000
	Getp15V	Read 15V : should be around 9AXX	99E30000
	Getm15V	Read -15V : should be around 66XX	99E40000
	GetMACtemp	Read MAC TEMP : should be around 0x9790 at ambient	99E50000
	GetSMECTemp	Read SMEC TEMP : should be around 0x9790 at ambient	99E60000
	GetBSMtemp	Read BSM TEMP : should be around 0x9790 at ambient	99E70000

2.2.12.3. BSM set up scenario for closed loop

This scenario aims to set up parameters which depends on both model and environment. These parameters are all the scale factors and control gains. The following parameters to be set up is only given as example for operation. Actual values shall be given after all ambient and 4K tests for every MCU model (QM1, QM2, Flight, Spare) in additional documentation.

Action	Command definition	Expected return	Command (HEX)
Power on sensors	SetCSensorPwr,on	80C00001	90C00001
	SetJSensorPwr,on	81400001	91400001
SET UP PID Parameters To Be Completed ...	SetCKp,ckp		90C8XXXX
Close the loops	SetChopLoopMode,1		90C20001
	SetJigLoopMode,1		91420001

2.2.12.4. BSM science operation: independent control (CHOPPER)

Command definition	Action	Command (Hex) :
SetBSMMove,0	Prepare the BSM mode in independant control	90C60000
SetChopTargetPosition	The chopper moves to desired position (XXXX=ADC value of desired Magneto-resistive sensor position (needs calibration table))	90C3XXXX
etc as many as desired ...		

2.2.12.5. BSM Science operation : synchronous control of both axis

Command scenario	Action	Command (hex) :
SetBSMMove,1 alias "Move BSM"	First time: configure to command the BSM in synchronous mode	9 0 C 6 0 0 0 1
SetJigTargetPosition,XXXX	Set up jiggle z position XXXX=ADC desired value of sensor	9 1 4 3 X X X X
SetChopTargetPosition,YYYY	Set up chopper position y YYYY=ADC desired value of sensor	9 0 C 3 Y Y Y Y
SetBSMMove,1 alias "Move BSM"	This updates parameters and Move jiggle and chopper synchronously	9 0 C 6 0 0 0 1
SetJigTargetPosition,XXXX	Set up jiggle z position	9 1 4 3 X X X X
SetChopTargetPosition,YYYY	Set up chopper y position	9 0 C 3 Y Y Y Y

SetBSMMove (1) alias "Move BSM"	This updates parameters and Move jiggle and chopper synchronously	9 0 C 6 0 0 0 1
Etc.... same pattern as long as desired		

2.2.12.6. SMEC latch off scenario

Command to be sent	Action	Command (Hex) :
SetSFeedForwardOffset,0	Apply a -100mA current on smec	90550000
Wait 15 seconds		
Setslatch,disengage	Remove latch pin	90430002
SetSFeedForwardOffset,8000	Apply a 0 mA current on smec	90558000
Wait 15 seconds		

2.2.12.7. SMEC set up scenario

Important Note:

This scenario aims to set up parameters which depends on both model and environment. These parameters are all the scale factors, PID gains, offset values. The following parameters to be set up is only given as example for operation. Actual values shall be given after all ambient and 4K tests for every MCU model (QM1, QM2, Flight, Spare) in additional documentation.

Typical scenario:

Command to be sent	Action	Command (Hex) :
FFGAIN,ffgainvalue	Open loop setup	9054xxxx
SET ENCODER PWR, level	Encoder set up	9040xxxx
SET SIGNAL1OFFSET,offset1		9058XXXX
SET SIGNAL2OFFSET,offset2		905AXXXX
SET LVDT PWR,1	LVDT set up	90410001
SET LVDTSCALE,lvdtscale		905FXXXX
SETLVDTOFFSET,lvdtoffset		905EXXXX
SETSKP,skp	Set Control parameters	904AXXXX
SETKD,skd		904BXXXX
SETKI,ski		904DXXXX
SETSIIntegrationLimit		904EXXXX
SETSRATELIMIT,ratelimit		9051XXXX

Environment and Model dependant parameters	Related Command	QM1 (SN1) Cqm 300K	QM1 (SN1) Cqm 4K
Ffgain	9054xxxx	xxxx:12000	12062

Encoder power level	9040xxxx	xxxx=7	4
Encoder offset 1	9058xxxx	xxxx=25000	31300
Encoder offset 2	905Axxxx	xxxx=29000	37500
LVDT scale	905Fxxxx	xxxx=TBD	9157
LVDT Offset	905Exxxx	xxxx=8000	8000
Kp	904Axxxx	3000	3000
Kd	904Bxxxx	7000	7000
Ki	904Dxxxx	1000	1000
Integration limit	904Exxxx	2000	2000
RateLimit	9051xxxx	300	300

2.2.12.8. Encoder init and closed loop operation

Command to be sent	Action	Command (Hex) :
SetSTrajEndPosition,0	Reset end position to 0	90450000
SetSFeedForwardOffset,0	Apply a -100mA current on smec	90550000
Wait 15 seconds		
SetSLoopMode,1	Close the loop and init counter on trajectory position (which should be 0)	90440001
SetSFeedForwardOffset, 0x8000	Apply a 0 mA current on smec to release	90558000
Wait 15 seconds		

2.2.12.9. SMEC science operation: performing a scan

Command to be sent	Action	Command (Hex) :
SetSTrajMode(0)	To be sure that the Smec trajectory is stopped (the motion remains at steady position)	9 0 4 9 0 0 0 0
SetSScanSpeed	500 um/sScan Speed	9 0 4 7 1 3 8 8
SetSScanRevSpeed	Specifies trajectory speed for flyback at same speed	9 0 5 6 1 3 8 8
SetScanNumber	Number of scan:10	9 0 4 8 0 0 0 A
SetSTrajStartPosition	- 3,3 mm start position = 4700um from mechanical limit The scenario considers the OPD / Smec mechanical limit distance = 8mm. The exact value shall be determined after calibration	9 0 4 6 1 2 5 C
SetSTrajEndPosition	+ 3.3 mm end position = 11300 um from mechanical limit	9 0 4 5 2 C 2 4
SetSTrajMode(2)	Start scan trajectory ("ScanStart")-> The smec moves according to setup.	9 0 4 9 0 0 0 2
Wait estimated time for the N scan for scenario ending		

2.2.12.10. Performing a step and integrate pattern

Command to be sent	Action	Command (Hex) :
SetSTrajMode (0)	To be sure that the Smec trajectory is stopped (the motion remains at steady position)	9 0 4 9 0 0 0 0
SetSScanSpeed	2000 um/sScan Speed ie max speed	9 0 4 7 4 E 2 0
SetSScanRevSpeed	Specifies trajectory speed for flyback at same speed (max speed)	9 0 5 6 4 E 2 0
SetSTrajEndPosition,-3300um	- 3,3 mm start position = 4700um from mechanical limit The scenario considers the OPD / Smec mechanical limit distance = 8mm. The exact value shall be determined after calibration	9 0 4 5 1 2 5 C
SetSTrajMode,1	Start step trajectory The smec moves according to setup.	9 0 4 9 0 0 0 1
SetSTrajEndPosition,-3280um	Move of 20um	9 0 4 5 1 2 7 0
SetSTrajEndPosition,-3260um	Move of 20um	9 0 4 5 1 2 8 4
Etc ...		

2.2.12.11. Power off of the SMEC axis control

Command to be sent	Action	Command (Hex) :
SetSTrajMode,1	step trajectory The smec moves according to setup.	9 0 4 9 0 0 0 1
SetSTrajEndPosition,-8000	Perform a step with target position = 0 (Move to mechanical limit)	9 0 4 5 0 0 0 0
Wait necessary time		
SetSLoopMode,6	Open the loop	9 0 4 4 0 0 0 6

2.2.12.12. Telemetry typical scenario

Command to be sent	Action	Command (Hex) :
SetTelemetryPacket10sampling,4ms	Set up the smec science packet to 4ms	9 1 C 0 0 0 0 A
SetTelemetryPacket12sampling,20ms	Set up the bsm science packet to 20ms	9 1 C 2 0 0 3 2
SetTelemetryFrameNumber,in f	Unlimited number of frames	9 1 C 3 F F F F
SetFrameStart,1	Start the frame emission from MCU to DPU	9 1 C 1 0 0 0 1

2.2.13. SCU specific command list summary

2.2.13.1. Command and parameter mapping

The following table shows respectively the bit mapping for CID and PAR field of a low-level command for the SCU.

CID11	CID10 to CID0	PAR15 to PAR0
R/ \bar{W}	Command Code	Parameter(s)

2.2.13.2. Write/read commands

Command Name	Argument(s)	Ranges List	Command verification	Execution Delay	CID
Set/GetFrameConf	Frame type Frame Rate	0/1 0 to 255	Get... cmd	$\leq 150 \mu\text{s}$	<u>083/883</u>
Set/GetSeqLength	Frame Number	0 to 31	Get... cmd	$\leq 150 \mu\text{s}$	<u>084/884</u>
Set/GetTempOnOff	On/Off Word	NA	Get... cmd	$\leq 150 \mu\text{s}$	<u>085/885</u>
Set/GetSubKOnOff	On/Off bit	0/1	Get... cmd	$\leq 150 \mu\text{s}$	<u>086/886</u>
Set/GetDRelOnOff	On/Off Word	NA	Get... cmd	$\leq 150 \mu\text{s}$	<u>087/887</u>
Set/GetSPHSHeatB	Heater Current (Set) Heater Voltage (Get)	0 to 4095 0 to 65355	Get... cmd	Set $\leq 150 \mu\text{s}$ Get $\leq 450 \mu\text{s}$	<u>0C5/8C5</u>
Set/GetEVHSHeatB	Heater Current (Set) Heater Voltage (Get)	0 to 4095 0 to 65355	Get... cmd	Set $\leq 150 \mu\text{s}$ Get $\leq 450 \mu\text{s}$	<u>0C4/8C4</u>
Set/GetTCHeaterB	Heater Current (Set) Heater Voltage (Get)	0 to 4095 0 to 65355	Get... cmd	Set $\leq 150 \mu\text{s}$ Get $\leq 450 \mu\text{s}$	<u>0C6/8C6</u>
Set/GetSPHeaterB	Heater Current (Set) Heater Voltage (Get)	0 to 4095 0 to 65355	Get... cmd	Set $\leq 150 \mu\text{s}$ Get $\leq 450 \mu\text{s}$	<u>0C7/8C7</u>
Set/GetPhCalBias	Heater Current (Set) Heater Voltage (Get)	0 to 4095 0 to 65355	Get... cmd	Set $\leq 150 \mu\text{s}$ Get $\leq 450 \mu\text{s}$	<u>0C8/8C8</u>
Set/GetSCal4Bias	Heater Current (Set) Heater Voltage (Get)	0 to 4095 0 to 65355	Get... cmd	Set $\leq 150 \mu\text{s}$ Get $\leq 450 \mu\text{s}$	<u>0CC/8CC</u>
Set/GetSCal2Bias	Heater Current (Set) Heater Voltage (Get)	0 to 4095 0 to 65355	Get... cmd	Set $\leq 150 \mu\text{s}$ Get $\leq 450 \mu\text{s}$	<u>0CA/8CA</u>
Set/GetScuContrl	ScuStatus reset ctrl bit ConvNum	0/1 0 to 3	Get... cmd	$\leq 150 \mu\text{s}$	<u>081/881</u>
Set/GetFrameCtrl	Frame transfer start/stop	0/1	Get... cmd	$\leq 150 \mu\text{s}$	<u>082/C82</u>

2.2.13.3. Read only commands

Command Name	Argument(s)	Ranges List	Command verification	Execution Delay	CID
GetScuStatus	ScuStatus	0 to FFFF hexa	NA	≤ 150 μs	880
GetCsuTempRd	CsuTemp	0 to FFFF hexa	NA	≤ 450 μs	8C0
GetTsuTempRd	TsuTemp	0 to FFFF hexa	NA	≤ 450 μs	8C1
GetPsuTemp1Rd	PsuTemp1	0 to FFFF hexa	NA	≤ 450 μs	8C2
GetPsuTemp2Rd	PsuTemp2	0 to FFFF hexa	NA	≤ 450 μs	8C3
GetScuCHTp05	ScuCHTp05	0 to FFFF hexa	NA	≤ 450 μs	8D0
GetScuCHTp09	ScuCHTp09	0 to FFFF hexa	NA	≤ 450 μs	8CF
GetScuCHTn09	ScuCHTn09	0 to FFFF hexa	NA	≤ 450 μs	8CE
GetCPHPtemp	CPHPtemp	0 to FFFF hexa	NA	≤ 450 μs	8E0
GetCPHStemp	CPHStemp	0 to FFFF hexa	NA	≤ 450 μs	8E1
GetCEHStemp	CEHStemp	0 to FFFF hexa	NA	≤ 450 μs	8E2
GetCSHTtemp	CSHTtemp	0 to FFFF hexa	NA	≤ 450 μs	8E3
GetSOBtemp	SOBPtemp	0 to FFFF hexa	NA	≤ 450 μs	8E4
GetSL0temp	SL0Ptemp	0 to FFFF hexa	NA	≤ 450 μs	8E5
GetPL0temp	PL0temp	0 to FFFF hexa	NA	≤ 450 μs	8E6
GetSUBtemp	SUBtemp	0 to FFFF hexa	NA	≤ 450 μs	8E7
GetBAFtemp	BAFPtemp	0 to FFFF hexa	NA	≤ 450 μs	8E8
GetBSMStemp	BSMStemp	0 to FFFF hexa	NA	≤ 450 μs	8E9
GetSCL2temp	SCL2temp	0 to FFFF hexa	NA	≤ 450 μs	8EA
GetSCL4temp	SCL4temp	0 to FFFF hexa	NA	≤ 450 μs	8EB
GetSCSTtemp	SCSTtemp	0 to FFFF hexa	NA	≤ 450 μs	8EC
GetFTSStemp	FTSStemp	0 to FFFF hexa	NA	≤ 450 μs	8ED
GetFTSMtemp	FTSMtemp	0 to FFFF hexa	NA	≤ 450 μs	8EE
GetBSMMtemp	BSMMtemp	0 to FFFF hexa	NA	≤ 450 μs	8EF
GetCEVTemp	CEVTemp	0 to FFFF hexa	NA	≤ 450 μs	8FE
GetPhCalVolt	PhCalVolt	0 to FFFF hexa	NA	≤ 450 μs	8C9
GetSCal4Volt	SCal4Volt	0 to FFFF hexa	NA	≤ 450 μs	8CD
GetSCal2Volt	SCal2Volt	0 to FFFF hexa	NA	≤ 450 μs	8CB
GetScuCHT25	ScuCHT25	0 to FFFF hexa	NA	≤ 450 μs	8D1
GetScuCHTref	ScuCHTref	0 to FFFF hexa	NA	≤ 450 μs	8D2
GetScuCHTgnd	ScuCHTgnd	0 to FFFF hexa	NA	≤ 450 μs	8D3
GetScuTHTref	ScuTHTref	0 to FFFF hexa	NA	≤ 450 μs	8F1
GetScuTHTgnd	ScuTHTgnd	0 to FFFF hexa	NA	≤ 450 μs	8F2

2.2.14. SCU command description

2.2.14.1. Read/Write commands

2.2.14.1.1. *FrameConf*

Command	Unit	Code	Description
SetFrameConf	SCU	083	Set frame rate and type (normal/test pattern)
Parameters	Location	Length	
FrameConf	0	16	Bit 15: FrameType Bit 14 to 08: don't care Bit 07 to 00: FrameRate

Command	Unit	Code	Description
GetFrameConf	SCU	883	Return frame rate and type (normal/test pattern)
Returned Parameter(s)	Location	Length	
FrameConf	0	16	Bit 15: FrameType Bit 14 to 08: null Bit 07 to 00: FrameRate

2.2.14.1.2. *SeqLength*

Command	Unit	Code	Description
SetSeqLength	SCU	084	Set number of frames per sequence
Parameters	Location	Length	
SeqLength	0	5	Bit 4 to 0: frame number

Command	Unit	Code	Description
GetFramRate	SCU	884	Return number of frame per sequence
Returned Parameters	Location	Length	
SeqLength	0	5	

2.2.14.1.3. *TempOnOff*

Command	Unit	Code	Description
SetTempOnOff	SCU	085	Set standard FPU temperature probes bias on/off
Parameters	Location	Length	
TempOnOff	0	16	Bit 15 to 0: 16 bits on/off word

Command	Unit	Code	Description
GetTempOnOff	SCU	885	Return standard FPU temperature probes bias on/off

Returned Parameters	Location	Length	
TempOnOff	0	16	Bit 15 to 0: 16 bits on/off word

2.2.14.1.4. *SubKOnOff*

Command	Unit	Code	Description
SetSubKOnOff	SCU	086	Set sub K temperature probe bias on/off
Parameters	Location	Length	
SubKOnOff	0	1	Bit 0: on/off flag

Command	Unit	Code	Description
GetSubKpOnOff	SCU	886	Return sub K temperature probe bias on/off
Returned Parameters	Location	Length	
SubKpOnOff	0	1	Bit 0: on/off flag

2.2.14.1.5. *DRelOnOff*

Command	Unit	Code	Description
SetDRelOnOff	SCU	087	Set DC/DC on/off command word
Parameters	Location	Length	
DRelOnOff	0	3	Bit 2 to 0: on/off flags

Command	Unit	Code	Description
GetDRelOnOff	SCU	887	Return DC/DC on/off command word
Returned Parameters	Location	Length	
DRelOnOff	0	3	Bit 2 to 0: on/off flags

2.2.14.1.6. *EVHSHeatB*

Command	Unit	Code	Description
SetEVHSHeatB	SCU	0C4	Set value of current applied to cryo-cooler evaporator heat switch
Parameters	Location	Length	
EVHSHeatCurSP	0	12	Current value (set DAC)

Command	Unit	Code	Description
GetEVHSHeatB	SCU	8C4	Get voltage across cryo-cooler evaporator heat switch
Returned Parameters	Location	Length	
EVHSHeatVolt	0	16	Heater voltage analog value

Note: due to wiring error of cryo-harness this command will affect Heat Switch of the Sorption Pump instead of the Evaporator.

2.2.14.1.7. *SPHSHeatB*

Command	Unit	Code	Description
SetSPHSHeatB	SCU	0C5	Set value of current applied to cryo-cooler sorption pump heat switch
Parameters	Location	Length	
SPHSHeatCurSP	0	12	Current value (set DAC)

Command	Unit	Code	Description
GetSPHSHeatB	SCU	8C5	Get voltage across cryo-cooler sorption pump heat switch
Returned Parameters	Location	Length	
SPHSHeatVolt	0	16	Heater voltage analog value

Note: due to wiring error of cryo-harness this command will affect Heat Switch of the Evaporator instead of the Sorption Pump.

2.2.14.1.8. *TCHeaterB*

Command	Unit	Code	Description
SetTCHeaterB	SCU	0C6	Set value of current applied to FPU thermal control heater
Parameters	Location	Length	
TCHeaterCurSP	0	12	Current value (set DAC)

Command	Unit	Code	Description
GetTCHeaterB	SCU	8C6	Get voltage across FPU thermal control heater
Returned Parameters	Location	Length	
TCHeaterVolt	0	16	Heater voltage analog value

2.2.14.1.9. *SPHeaterB*

Command	Unit	Code	Description
SetSPHeaterB	SCU	0C7	Set value of current applied to cryo-cooler sorption pump
Parameters	Location	Length	
SPHeaterCurSP	0	12	Current value (set DAC)

Command	Unit	Code	Description
GetSPHeaterB	SCU	8C7	Get voltage across cryo-cooler sorption pump
Returned Parameters	Location	Length	
SPHeaterVolt	0	16	Heater voltage analog value

2.2.14.1.10. *PhCalBias*

Command	Unit	Code	Description
SetPhCalBias	SCU	0C8	Set value of current applied to Stimulus Source PhCal (set DAC)
Parameters	Location	Length	

PhCalCurSP	0	12	Current value
------------	---	----	---------------

Command	Unit	Code	Description
GetPhCalBias	SCU	8C8	Get current in Stimulus Source 1 PhCal
Returned Parameters	Location	Length	
PhCalCur	0	16	Stimulus source current analog value

2.2.14.1.11. *SCal2Bias*

Command	Unit	Code	Description
SetSCal2Bias	SCU	0CA	Set value of current applied to Stimulus Source SCal 2%
Parameters	Location	Length	
SCal2CurSP	0	12	Current value

Command	Unit	Code	Description
GetSCal2Bias	SCU	8CA	Get current in Stimulus Source SCal 2%
Returned Parameters	Location	Length	
SCal2Cur	0	16	Stimulus source current analog value

2.2.14.1.12. *SCal4Bias*

Command	Unit	Code	Description
SetSCal4Bias	SCU	0CC	Set value of current applied to Stimulus Source SCal 4%
Parameters	Location	Length	
SCal4CurSP	0	12	Current value

Command	Unit	Code	Description
GetSCal4Bias	SCU	8CC	Get current in Stimulus Source SCal 4%
Returned Parameters	Location	Length	
SCal4Cur	0	16	Stimulus source current analog value

2.2.14.1.13. *ScuContrl*

Command	Unit	Code	Description
SetScuContrl	SCU	081	Resets or enables ADC latch-up flag detection Configures the number of A to D conversions
Parameters	Location	Length	
ScuContrl	0	1	ScuContrl function control parameter
ConvNum	1	2	Number of conversions

Command	Unit	Code	Description
GetScuContrl	SCU	881	Get ScuContrl & ConvNum parameter status
Returned Parameter(s)	Location	Length	
SetScuContrl	0	1	ScuContrl function control parameter
ConvNum	1	2	Number of conversions

2.2.14.1.14. FrameCtrl

Command	Unit	Code	Description
SetFrameCtrl	SCU	082	Initiate frame sequence transfer
Parameters	Location	Length	
FrameCtrl	0	1	On/off frame transfer (auto cleared after sequence completion)

Command	Unit	Code	Description
GetFrameCtrl	SCU	882	Get FrameCtrl parameter status
Returned Parameter(s)	Location	Length	
FrameCtrl	0	1	

2.2.14.2. Read only commands

2.2.14.2.1. ScuStatus

Command	Unit	Code	Description
GetScuStatus	SCU	880	Get SCU electronics status
Parameters	Location	Length	
ScuStatus	0	3	TEMP & CCHK ADC latch-up status register - Reset by the ScuContrl command

2.2.14.2.2. CsuTempRd

Command	Unit	Code	Description
GetCsuTempRd	SCU	8C0	Return CCHK board temperature sensor value
Returned Parameter(s)	Location	Length	
CsuTempRd	0	16	Probe current analog value (function of the temperature)

2.2.14.2.3. TsuTempRd

Command	Unit	Code	Description
GetTsuTempRd	SCU	8C1	Return TEMP board temperature sensor value
Returned Parameter(s)	Location	Length	
TsuTempRd	0	16	Probe current analog value (function of the temperature)

2.2.14.2.4. PsuTmp1Rd

Command	Unit	Code	Description
GetPsuTmp1Rd	SCU	8C2	Return PSU board temperature sensor 1 value
Returned Parameter(s)	Location	Length	
PsuTmp1Rd	0	16	Probe current analog value (function of the temperature)

2.2.14.2.5. *PsuTmp2Rd*

Command	Unit	Code	Description
GetPsuTmp2Rd	SCU	8C3	Return PSU board temperature sensor 2 value
Returned Parameter(s)	Location	Length	
PsuTmp2Rd	0	16	Probe current analog value (function of the temperature)

2.2.14.2.6. *PhCalVolt*

Command	Unit	Code	Description
GetPhCalVolt	SCU	8C9	Get voltage across Stimulus Source PCal
Parameters	Location	Length	
PhCalVolt	0	16	Voltage analog value

2.2.14.2.7. *SCal2Volt*

Command	Unit	Code	Description
GetSCal2Volt	SCU	8CB	Get voltage across Stimulus Source SCal2
Parameters	Location	Length	
SCal2Volt	0	16	Voltage analog value

2.2.14.2.8. *SCal4Volt*

Command	Unit	Code	Description
GetSCal4Volt	SCU	8CD	Get voltage across Stimulus Source SCal4
Parameters	Location	Length	
SCal4Volt	0	16	Voltage analog value

2.2.14.2.9. *ScuCHTn09*

Command	Unit	Code	Description
GetScuCHTn09	SCU	8CE	Return value of -09V of SCU/CCHK&TEMP
Returned Parameter(s)	Location	Length	
ScuCHTn09	0	16	Voltage analog value

2.2.14.2.10. *ScuCHTp09*

Command	Unit	Code	Description
GetScuCHTp09	SCU	8CF	Return value of +09V of SCU/CCHK&TEMP

Returned Parameter(s)	Location	Length	
ScuCHTp09	0	16	Voltage analog value

2.2.14.2.11. *ScuCHTp05*

Command	Unit	Code	Description
GetScuCHTp05	SCU	8D0	Return value of +05V of SCU/CCHK&TEMP
Returned Parameter(s)	Location	Length	
ScuCHTp05	0	16	Voltage analog value

2.2.14.2.12. *ScuCHT25*

Command	Unit	Code	Description
GetScuCHTref	SCU	8D1	Return CCHK internal 2.5 Vreference voltage - For internal calibration purpose
Returned Parameter(s)	Location	Length	
ScuCHTref	0	16	CCHK internal reference voltage measure

2.2.14.2.13. *ScuCHTref*

Command	Unit	Code	Description
GetScuCHTref	SCU	8D2	Return CCHK internal reference voltage - For internal calibration purpose
Returned Parameter(s)	Location	Length	
ScuCHTref	0	16	CCHK internal reference voltage measure

2.2.14.2.14. *ScuCHTgnd*

Command	Unit	Code	Description
GetScuCHTgnd	SCU	8D3	Return CCHK internal ground reference voltage - For internal calibration purpose
Returned Parameter(s)	Location	Length	
ScuCHTgnd	0	16	CCHK internal ground reference voltage measure

2.2.14.2.15. *CPHPtemp*

Command	Unit	Code	Description
GetCPHPtemp	SCU	8E0	Return FPU temperature of cryo-cooler sorption pump heater
Returned Parameter(s)	Location	Length	
CPHPtemp	0	16	Probe current analog value (function of the temperature)

2.2.14.2.16. *CPHStemp*

Command	Unit	Code	Description
GetCPHStemp	SCU	8E1	Return FPU temperature of cryo-cooler sorption pump heat switch
Returned Parameter(s)	Location	Length	
CPHStemp	0	16	Probe current analog value (function of the temperature)

2.2.14.2.17. *CEHStemp*

Command	Unit	Code	Description
GetCEHStemp	SCU	8E2	Return FPU temperature of cryo-cooler evaporator heat switch
Returned Parameter(s)	Location	Length	
CEHStemp	0	16	Probe current analog value (function of the temperature)

2.2.14.2.18. *CSHTtemp*

Command	Unit	Code	Description
GetCSHTtemp	SCU	8E3	Return FPU temperature of cryo-cooler thermal shunt
Returned Parameter(s)	Location	Length	
CSHTtemp	0	16	Probe current analog value (function of the temperature)

2.2.14.2.19. *SOBtemp*

Command	Unit	Code	Description
GetSOBtemp	SCU	8E4	Return FPU temperature SPIRE optical bench
Returned Parameter(s)	Location	Length	
SOBtemp	0	16	Probe current analog value (function of the temperature)

2.2.14.2.20. *SL0temp*

Command	Unit	Code	Description
GetSL0temp	SCU	8E5	Return FPU temperature of spectrometer L0
Returned Parameter(s)	Location	Length	
SL0temp	0	16	Probe current analog value (function of the temperature)

2.2.14.2.21. *PL0temp*

Command	Unit	Code	Description
GetPL0temp	SCU	8E6	Return FPU temperature of photometer L0
Returned Parameter(s)	Location	Length	
PL0temp	0	16	Probe current analog value (function of the temperature)

2.2.14.2.22. SUBtemp

Command	Unit	Code	Description
Get SUBtemp	SCU	8E7	Return FPU temperature of optical sub-bench
Returned Parameter(s)	Location	Length	
SUBtemp	0	16	Probe current analog value (function of the temperature)

2.2.14.2.23. BAFtemp

Command	Unit	Code	Description
GetBAFtemp	SCU	8E8	Return FPU temperature of input baffle
Returned Parameter(s)	Location	Length	
BAFtemp	0	16	Probe current analog value (function of the temperature)

2.2.14.2.24. BSMStemp

Command	Unit	Code	Description
GetBSMStemp	SCU	8E9	Return FPU temperature of BSM/SOB i/f
Returned Parameter(s)	Location	Length	
BSMStemp	0	16	Probe current analog value (function of the temperature)

2.2.14.2.25. SCL2temp

Command	Unit	Code	Description
Get SCL2temp	SCU	8EA	Return FPU temperature of spectrometer calibrator %2
Returned Parameter(s)	Location	Length	
SCL2temp	0	16	Probe current analog value (function of the temperature)

2.2.14.2.26. SCL4temp

Command	Unit	Code	Description
GetSCL4temp	SCU	8EB	Return FPU temperature of spectrometer calibrator %4
Returned Parameter(s)	Location	Length	
SCL4temp	0	16	Probe current analog value (function of the temperature)

2.2.14.2.27. SCSTtemp

Command	Unit	Code	Description
GetSCSTtemp	SCU	8EC	Return FPU temperature spectrometer calibration flange
Returned Parameter(s)	Location	Length	
SCSTtemp	0	16	Probe current analog value (function of the temperature)

2.2.14.2.28. FTSStemp

Command	Unit	Code	Description
GetFTSStemp	SCU	8ED	Return FPU temperature of SMEC/SOB i/f
Returned Parameter(s)	Location	Length	
FTSStemp	0	16	Probe current analog value (function of the temperature)

2.2.14.2.29. FTSMtemp

Command	Unit	Code	Description
GetFTSMtemp	SCU	8EE	Return FPU temperature of SMEC mechanism
Returned Parameter(s)	Location	Length	
FTSMtemp	0	16	Probe current analog value (function of the temperature)

2.2.14.2.30. BSMMtemp

Command	Unit	Code	Description
GetBSMMtemp	SCU	8EF	Return FPU temperature of BSM mechanism
Returned Parameter(s)	Location	Length	
BSMMtemp	0	16	Probe current analog value (function of the temperature)

2.2.14.2.31. CEVTemp

Command	Unit	Code	Description
GetCEVTemp	SCU	8F0	Return subK temperature of cryo-cooler evaporator
Returned Parameter(s)	Location	Length	
CEVTemp	0	16	Probe voltage analog value (function of the temperature)

2.2.14.2.32. ScuTHTref

Command	Unit	Code	Description
GetScuTHTref	SCU	8F1	Return TEMP internal reference voltage - For internal calibration purpose
Returned Parameter(s)	Location	Length	
ScuTHTref	0	16	TEMP internal reference voltage measure

2.2.14.2.33. ScuTHTgnd

Command	Unit	Code	Description
GetScuTHTgnd	SCU	8F2	Return TEMP internal ground reference voltage - For internal calibration purpose

Returned Parameter(s)	Location	Length	
ScuTHTgnd	0	16	TEMP internal ground reference voltage measure

2.2.15. SCU parameters description

Name	Type	Size	Conversion	Limits	Description
ScuStatus	Discrete	3	Bit 2 : Mirrors FrameCtrl parameter Bit 1 : TEMP ADC latch-up is set Bit 0 : CCHK ADC latch-up is set		
ScuContrl	Discrete	1	0 : resets latch-up status bits in ScuStatus 1 : enables latch-up detection	0 / 1	Control CCHK and TEMP ADCs latch-up flags detection
ConvNum *	Discrete	2	$Number_of_conversions = 2^{ConvNum}$	0 to 2	A to D conversion number
FrameRate	Discrete	8	$Frame_per_s = \frac{80}{FrameRate + 1}$	0 to 255	SCU frame rate
FrameType	Discrete	1	0 : Normal 1 : Test Pattern	0 / 1	SCU frame type
FrameCtrl	Discrete	1	0 : stop frame sequence 1 : start frame sequence (cleared at end of sequence)	0 / 1	Control the SCU frame transfer
SeqLength	Discrete	5	0 for infinite and 1 to 31	0 to 31	Number of frame in a sequence
TempOnOff	Discrete	16	Bit 15 to 12: BSMM,FTSM,FTSS,SCST Bit 11 to 8: SCL4,SCL2,BSMS,BAF Bit 7 to 4: SUB,PL0,SL0,SOB Bit 3 to 0 : CSHT,CEHS,CPHS,CPHP	Each bit 0 (off) / 1 (on)	Temp. sensor bias on/off control word
SubKOnOff	Discrete	1	0 : Bias off 1 : Bias on	0 / 1	CEV temp. sensor on/off control
DRelOnOff **	Discrete	3	Bit 2 : MCU Bit 1 : LIA_S Bit 0 : LIA_P	Each bit 0 (off) / 1 (on)	DRCU S/S power control word
SPHSHeatCurSP	Analogue	12	$I_{SP_HS} = I_{SP_HS_max} \cdot \frac{SPHSHeatCurSP}{4095}$ $I_{SP_HS_max} = 1.61\text{ mA}$	0 to 4095	Current in sorption pump heat switch (set point)
EVHSHeatCurSP	Analogue	12	$I_{EV_HS} = I_{EV_HS_max} \cdot \frac{EVHSHeatCurSP}{4095}$ $I_{EV_HS_max} = 1.61\text{ mA}$	0 to 4095	Current in evaporator heat switch (set point)
TCHeaterCurSP	Analogue	12	$I_{TC} = I_{TC_max} \cdot \frac{TCHeaterCurSP}{4095}$ $I_{TC_max} = 4.47\text{ }\mu\text{A}$	0 to 4095	Current in TC heater (set point)
SPHeaterCurSP	Analogue	12	$I_{SP_Heater} = I_{SP_Heater_max} \cdot \frac{SPHeaterCurSP}{4095}$ $I_{SP_Heater_max} = xx\text{ mA}$	0 to 4095	Current in sorption pump heater (set point)
SPHSHeatVolt	Analogue	16	$V_{SP_HS} = 7.629 \cdot 10^{-5} \cdot SPHSHeatVolt$	-32768 to 32767	Voltage across sorption pump heat switch
EVHSHeatVolt	Analogue	16	$V_{EV_HS} = 7.629 \cdot 10^{-5} \cdot EVHSHeatVolt$	-32768 to 32767	Voltage across evaporator heat switch

TCHeaterVolt	Analogue	16	$V_{TC} = 1.240 \cdot 10^{-4} \cdot TCHeaterVolt$	-32768 to 32767	Voltage across TC heater
SPHeaterVolt	Analogue	16	$V_{SP_Heater} = 6.103 \cdot 10^{-4} \cdot SPHeaterVolt$	-32768 to 32767	Voltage across sorption pump heater
PhCalCurSP	Analogue	12	$I_{PhCal} = I_{SP_Heater_max} \cdot \frac{PhCalCurSP}{4095}$ $I_{PhCal_max} = 7.16 \text{ mA}$	-32768 to 32767	Current in PhCal (set point)
SCal4CurSP	Analogue	12	$I_{SPCal4} = I_{SP_Heater_max} \cdot \frac{SCal4CurSP}{4095}$ $I_{SPCal4_max} = 5.58 \text{ mA}$	0 to 4095	Current in SCal4 (set point)
SCal2CurSP	Analogue	12	$I_{SPCal2} = I_{SP_Heater_max} \cdot \frac{SCal2CurSP}{4095}$ $I_{SCal2} = 5.58 \text{ mA}$	0 to 4095	Current in SCal2 (set point)
PhCalCur	Analogue	16	$I_{PhCal} = 2.483 \cdot 10^{-7} \cdot PhCalCur$	-32768 to 32767	Current in PhCal (measured)
SCal4Cur	Analogue	16	$I_{SCal4} = 1.776 \cdot 10^{-7} \cdot SCal4Cur$	-32768 to 32767	Current in SCal4% (measured)
SCal2Cur	Analogue	16	$I_{SCal2} = 1.776 \cdot 10^{-7} \cdot SCal2Cur$	-32768 to 32767	Current in SCal2% (measured)
PhCalVolt	Analogue	16	$V_{PhCal} = 7.629 \cdot 10^{-5} \cdot PhCalVolt$	-32768 to 32767	Voltage across PhCal (measured)
SCal4Volt	Analogue	16	$V_{SCal4} = 1.139 \cdot 10^{-4} \cdot SCal4Volt$	-32768 to 32767	Voltage across SCal4% (measured)
SCal2Volt	Analogue	16	$V_{SCal2} = 1.139 \cdot 10^{-4} \cdot SCal2Volt$	-32768 to 32767	Voltage across SCal2% (measured)
ScuCHTp05	Analogue	16	$V_{P05} = 1.904 \cdot 10^{-4} \cdot ScuCHTp05$	-32768 to 32767	SCU digital supply voltage (measured)
ScuCHTp09	Analogue	16	$V_{P09} = 3.376 \cdot 10^{-4} \cdot ScuCHTp09$	-32768 to 32767	SCU analog supply voltage (measured)
ScuCHTn09	Analogue	16	$V_{N09} = 3.376 \cdot 10^{-4} \cdot ScuCHTn09$	-32768 to 32767	SCU analog supply voltage (measured)
ScuCHTp25	Analogue	16	$V_{P25} = 1.526 \cdot 10^{-4} \cdot ScuCHTp25$	-32768 to 32767	SCU FPGA supply voltage (measured)
ScuCHTref	Analogue	16	$V_{REF} = 7.629 \cdot 10^{-5} \cdot ScuCHTref$	-32768 to 32767	SCU voltage reference (measured)
ScuCHTgnd	Analogue	16	$V_{P25} = 1.526 \cdot 10^{-4} \cdot ScuCHTgnd$	-32768 to 32767	SCU 0V voltage (measured)
CPHPtemp	Analogue	16	$R_{CPHP} = \frac{3597926}{CPHPtemp}$	-32768 to 32767	Current in CPHP temp. probe (converted to Ω)
CPHStemp	Analogue	16	$R_{CPHS} = \frac{5406720}{CPHStemp}$	-32768 to 32767	Current in CPHS temp. probe (converted to Ω)
CEHStemp	Analogue	16	$R_{CEHS} = \frac{5406720}{CEHStemp}$	-32768 to 32767	Current in CEHS temp. probe (converted to Ω)

CSHTtemp	Analogue	16	$R_{CSHT} = \frac{8519680}{CSHTtemp}$	-32768 to 32767	Current in CSHT temp. probe (converted to Ω)
SOBtemp	Analogue	16	$R_{SOB} = \frac{1251738}{SOBtemp}$	-32768 to 32767	Current in SOB temp. probe (converted to Ω)
SL0temp	Analogue	16	$R_{SL0} = \frac{8519680}{SL0temp}$	-32768 to 32767	Current in SL0 temp. probe (converted to Ω)
PL0temp	Analogue	16	$R_{PL0} = \frac{8519680}{PL0temp}$	-32768 to 32767	Current in PL0 temp. probe (converted to Ω)
SUBtemp	Analogue	16	$R_{SUB} = \frac{2123366}{SUBtemp}$	-32768 to 32767	Current in SUB temp. probe (converted to Ω)
BAFtemp	Analogue	16	$R_{BAF} = \frac{2123366}{BAFtemp}$	-32768 to 32767	Current in BAF temp. probe (converted to Ω)e
BSMStemp	Analogue	16	$R_{BSMS} = \frac{2896691}{BSMStemp}$	-32768 to 32767	Current in BSMS temp. probe (converted to Ω)
SCL2temp	Analogue	16	$R_{SCL2} = \frac{2896691}{SCL2temp}$	-32768 to 32767	Current in SCL2 temp. probe (converted to Ω)
SCL4temp	Analogue	16	$R_{SCL4} = \frac{2896691}{SCL4temp}$	-32768 to 32767	Current in SCL4 temp. probe (converted to Ω)
SCSTtemp	Analogue	16	$R_{SCST} = \frac{3597926}{SCSTtemp}$	-32768 to 32767	Current in SCST temp. probe (converted to Ω)
FTSStemp	Analogue	16	$R_{FTSS} = \frac{2123366}{FTSStemp}$	-32768 to 32767	Current in FTSS temp. probe (converted to Ω)
FTSMtemp	Analogue	16	$R_{FTSM} = \frac{6553600}{FTSMtemp}$	-32768 to 32767	Current in FTSM temp. probe (converted to Ω)
BSMMtemp	Analogue	16	$R_{BSMM} = \frac{6553600}{BSMMtemp}$	-32768 to 32767	Current in BSMM temp. probe (converted to Ω)
SubKTempP	Analogue	16		-32768 to 32767	Voltage across CEV temp. probe (converted to Ω)
CsuTempRd	Analogue	16	$T_{CCHK} = 0.1526 \cdot CsuTempRd$	-32768 to 32767	Temperature (K) of CCHK board
TsuTempRd	Analogue	16	$T_{TEMP} = 0.1526 \cdot TsuTempRd$	-32768 to 32767	Temperature (K) of TEMP board
PsuTempRd1	Analogue	16	$T1_{PSU} = 0.1526 \cdot PsuTempRd1$	-32768 to 32767	Temperature (K) of PSU
PsuTempRd2	Analogue	16	$T2_{PSU} = 0.1526 \cdot PsuTempRd2$	-32768 to 32767	Temperature (K) of PSU

* This parameter defines the number of successive A to D samplings (between 1 and 8) of the analog housekeeping parameters. The successive samplings are averaged before being transmitted to the DPU (either by a get parameter command or within frames).

** LIA_P bit has higher priority than LIA_S bit. This has no impact when on/off command sequence is correctly executed; nominal sequence is:

- Command power-off of the initially on boards (either LIA_P or LIA_S)
- Command power-on of the other set of boards (either LIA_S or LIA_P)

If a “power on LIA_S” is sent while LIA_P board are already powered on the command will not have any effect. If both power on LIA_P and LIA_S is requested only LIA_P boards will be effectively powered on.

2.2.16. SCU typical commanding scenarios

NA

2.3. Data Interface

2.3.1. General Information

The Data Interface is dedicated to data transfer from subsystem to DPU. Three independent “Data Interface” are required allowing simultaneous DRCU data transfer.

This interface is unidirectional: data are transferred from the DRCU sub-units to the DPU acquisition electronics. Fixed data packets are defined according to sub-unit operating mode. This data packet contents both scientific data (i.e. bolometer signal) and/or housekeeping parameters.

2.3.2. Overall Interface Diagram

The Command Interface diagram is given in figure 2.3-a Prime and Redundant interfaces are shown.

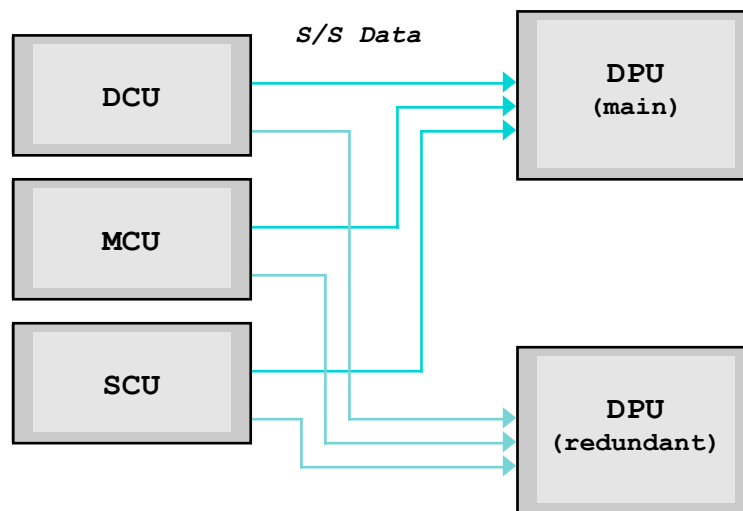

Figure 2.3-a

2.3.3. Interface Circuit

The interface is a synchronous serial link based on one data line (DTA) associated to a clock line (CLK) for bit synchronisation and a gate line (GAT) for word synchronisation. Each sub-unit implements a complete set of signals: that is the DPU implements 3 totally independent Data interfaces each having 3 receivers (as shown by figure 2.3-b).

The interface uses the balanced line RS422 electrical standard based on 26C31 and 26C32 transmitter and receiver type respectively.

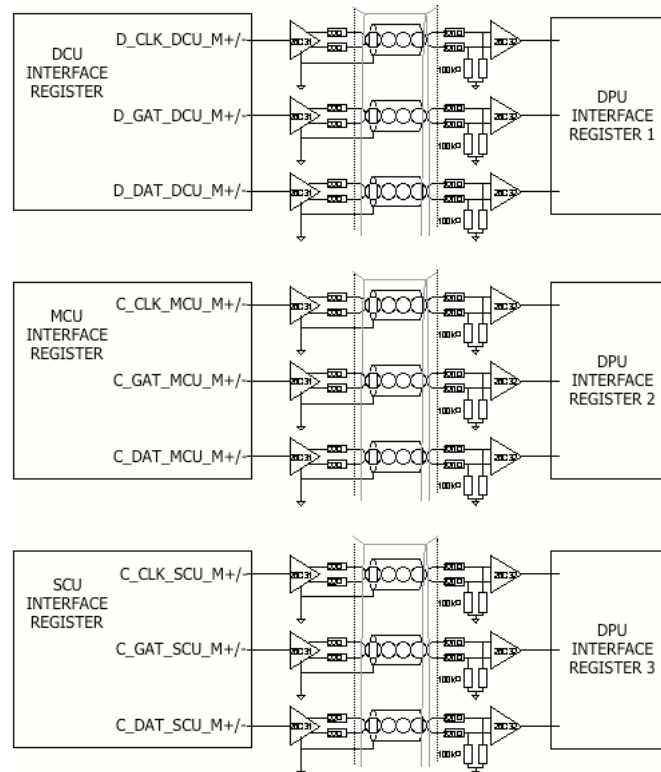

Figure 2.3-b - Electrical configuration

2.3.4. Word definition

Word definition is subsystem dependent. Data are currently 16-bit encoded and correspond to bolometer signal, mechanisms motion parameters, instrument temperature and all other housekeeping channels.

In order to deal with the latch-up effect of the analogue to digital converters (see RD01), which cause the generation of wrong data until the converter recovers full performances, a specific “invalid” data identifier is defined. This avoids the DRCU to transfer unpredictable packet length following a cosmic ray impact on the converter and later on-ground misanalysis.

These data words are defined as follow:



Figure 3.4-a - Data Word Definition

DAT15 to DAT0: data

Note: • MSB (DAT15) is transmitted first

2.3.5. General Frame Definition

Data frame length and structure are defined regarding the DRCU sub-unit and its mode of operation. The sub-systems data structures are encapsulated into a common frame structure as described bellow (except two MCU modes).

The frame is composed of transmitted successively according to the order:

- a length word (1 word)
- a frame ID (1 word)
- a data structure (n words)
- a frame time (2 words)
- a check word (1 word)

2.3.5.1. Length

The “length” field (16 bits) is placed at the head of the frame. It indicates the number of 16-bit words of the frame (including all the fields). Along with the “frame ID” and “check word” fields this field allows frame consistency checking by the receiver unit.

2.3.5.2. Frame ID

The “frame ID” field is a 16-bit word following the “length” word. Along with the “length” field and the “check” word it allows data consistency checking. In case the check fails the DPU takes action to resynchronise with the data stream.

The purpose of the frame ID is to enable identifying to frame after packing by the DPU. A specific code is allocated for each frame type of each DRCU S/S. The following table shows the identifier allocation:

UNIT	Frame Type	Frame ID (hex)
DCU	Ph Full Array	00
DCU	Sp Full array	01
DCU	P-SW	02
DCU	P-MW	03
DCU	P-LW	04
DCU	S-SW	05
DCU	S-LW	06
DCU	Ph Offset	07
DCU	Sp Offset	08
DCU	Ph Full Test Pattern	09
DCU	P-SW Test Pattern	0A
DCU	P-MW Test Pattern	0B
DCU	P-LW Test Pattern	0C

UNIT	Frame Type	Frame ID (hex)
DCU	Sp Test Pattern	0D
DCU	S-SW Test Pattern	0E
DCU	S-LW Test Pattern	0F
MCU	SMEC scan	10
MCU	SMEC Step	11
MCU	BSM Chop	12
MCU	Jiggle	13
MCU	Engineering	14
MCU	Test Pattern	15
MCU	Not Allocated	16-1F
SCU	HSK	20
SCU	Test Pattern	21
SCU	Not Allocated	22-2F

Note: ADCx data #n are unsigned 16-bit word. The resolution for the data is defined by the overall gains of the chains (photometer and spectrometer have different gains) and the resolution of the A to D converters. The following table defines roughly those resolutions according to the design:

Chain	Resolution (nV/bit)
Photometer	13.92
Spectrometer	21.59
T/C	37.75

Note : resolution is derived from the chain overall gain. As described by the “DCU Design Document” (§3.8.3.5.1) gains are bias frequency dependent. Above resolutions are given for maximum gains.

The following cross table shows the corresponding Frame ID for each DCU configuration status:

DCU Configuration	Frame ID	Frame Format	Frame Length
Photometer Full Array	00	T2	294
Spectrometer Full Array	01	T2	78
Photometer SW	02	T1-PSW	150
Photometer MW	03	T1-PMW	102
Photometer LW	04	T1-PLW	54
Spectrometer SW	05	T1-SSW	54
Spectrometer LW	06	T1-SLW	30
Photometer Offset	07	T2	294
Spectrometer Offset	08	T2	78
Photometer Test Pattern Full Array	09	T3	294
Photometer Test Pattern SW	0A	T3	150
Photometer Test Pattern MW	0B	T3	102
Photometer Test Pattern LW	0C	T3	54
Spectrometer Test Pattern Full Array	0D	T3	78
Spectrometer Test Pattern SW	0E	T3	54
Spectrometer Test Pattern LW	0F	T3	30

Reminder: the DCU data interface configuration is configured by means of the “SetDataMode” command.

2.3.5.3.2. DCU Photometer Full Array pixel arrangement

Index	0	1	2	3	4	5	6	7
0	CH1/LIA P1	CH2/LIA P1	CH3/LIA P1	CH4/LIA P1	CH5/LIA P1	CH6/LIA P1	CH7/LIA P1	CH8/LIA P1
8	CH9/LIA P1	CH10/LIA P1	CH11/LIA P1	CH12/LIA P1	CH13/LIA P1	CH14/LIA P1	CH15/LIA P1	CH16/LIA P1
16	CH17/LIA P1	CH18/LIA P1	CH19/LIA P1	CH20/LIA P1	CH21/LIA P1	CH22/LIA P1	CH23/LIA P1	CH24/LIA P1
24	CH25/LIA P1	CH26/LIA P1	CH27/LIA P1	CH28/LIA P1	CH29/LIA P1	CH30/LIA P1	CH31/LIA P1	CH32/LIA P1
32	CH1/LIA P2	CH2/LIA P2	CH3/LIA P2	CH4/LIA P2	CH5/LIA P2	CH6/LIA P2	CH7/LIA P2	CH8/LIA P2
40	CH9/LIA P2	CH10/LIA P2	CH11/LIA P2	CH12/LIA P2	CH13/LIA P2	CH14/LIA P2	CH15/LIA P2	CH16/LIA P2
48	CH17/LIA P2	CH18/LIA P2	CH19/LIA P2	CH20/LIA P2	CH21/LIA P2	CH22/LIA P2	CH23/LIA P2	CH24/LIA P2
56	CH25/LIA P2	CH26/LIA P2	CH27/LIA P2	CH28/LIA P2	CH29/LIA P2	CH30/LIA P2	CH31/LIA P2	CH32/LIA P2
64	CH1/LIA P3	CH2/LIA P3	CH3/LIA P3	CH4/LIA P3	CH5/LIA P3	CH6/LIA P3	CH7/LIA P3	CH8/LIA P3
72	CH9/LIA P3	CH10/LIA P3	CH11/LIA P3	CH12/LIA P3	CH13/LIA P3	CH14/LIA P3	CH15/LIA P3	CH16/LIA P3
80	CH17/LIA P3	CH18/LIA P3	CH19/LIA P3	CH20/LIA P3	CH21/LIA P3	CH22/LIA P3	CH23/LIA P3	CH24/LIA P3
88	CH25/LIA P3	CH26/LIA P3	CH27/LIA P3	CH28/LIA P3	CH29/LIA P3	CH30/LIA P3	CH31/LIA P3	CH32/LIA P3
96	CH1/LIA P4	CH2/LIA P4	CH3/LIA P4	CH4/LIA P4	CH5/LIA P4	CH6/LIA P4	CH7/LIA P4	CH8/LIA P4
104	CH9/LIA P4	CH10/LIA P4	CH11/LIA P4	CH12/LIA P4	CH13/LIA P4	CH14/LIA P4	CH15/LIA P4	CH16/LIA P4
112	CH17/LIA P4	CH18/LIA P4	CH19/LIA P4	CH20/LIA P4	CH21/LIA P4	CH22/LIA P4	CH23/LIA P4	CH24/LIA P4
120	CH25/LIA P4	CH26/LIA P4	CH27/LIA P4	CH28/LIA P4	CH29/LIA P4	CH30/LIA P4	CH31/LIA P4	CH32/LIA P4
128	CH1/LIA P5	CH2/LIA P5	CH3/LIA P5	CH4/LIA P5	CH5/LIA P5	CH6/LIA P5	CH7/LIA P5	CH8/LIA P5
136	CH9/LIA P5	CH10/LIA P5	CH11/LIA P5	CH12/LIA P5	CH13/LIA P5	CH14/LIA P5	CH15/LIA P5	CH16/LIA P5
144	CH17/LIA P5	CH18/LIA P5	CH19/LIA P5	CH20/LIA P5	CH21/LIA P5	CH22/LIA P5	CH23/LIA P5	CH24/LIA P5
152	CH25/LIA P5	CH26/LIA P5	CH27/LIA P5	CH28/LIA P5	CH29/LIA P5	CH30/LIA P5	CH31/LIA P5	CH32/LIA P5
160	CH1/LIA P6	CH2/LIA P6	CH3/LIA P6	CH4/LIA P6	CH5/LIA P6	CH6/LIA P6	CH7/LIA P6	CH8/LIA P6
168	CH9/LIA P6	CH10/LIA P6	CH11/LIA P6	CH12/LIA P6	CH13/LIA P6	CH14/LIA P6	CH15/LIA P6	CH16/LIA P6
176	CH17/LIA P6	CH18/LIA P6	CH19/LIA P6	CH20/LIA P6	CH21/LIA P6	CH22/LIA P6	CH23/LIA P6	CH24/LIA P6
184	CH25/LIA P6	CH26/LIA P6	CH27/LIA P6	CH28/LIA P6	CH29/LIA P6	CH30/LIA P6	CH31/LIA P6	CH32/LIA P6
192	CH1/LIA P7	CH2/LIA P7	CH3/LIA P7	CH4/LIA P7	CH5/LIA P7	CH6/LIA P7	CH7/LIA P7	CH8/LIA P7
200	CH9/LIA P7	CH10/LIA P7	CH11/LIA P7	CH12/LIA P7	CH13/LIA P7	CH14/LIA P7	CH15/LIA P7	CH16/LIA P7
208	CH17/LIA P7	CH18/LIA P7	CH19/LIA P7	CH20/LIA P7	CH21/LIA P7	CH22/LIA P7	CH23/LIA P7	CH24/LIA P7
216	CH25/LIA P7	CH26/LIA P7	CH27/LIA P7	CH28/LIA P7	CH29/LIA P7	CH30/LIA P7	CH31/LIA P7	CH32/LIA P7
224	CH1/LIA P8	CH2/LIA P8	CH3/LIA P8	CH4/LIA P8	CH5/LIA P8	CH6/LIA P8	CH7/LIA P8	CH8/LIA P8
232	CH9/LIA P8	CH10/LIA P8	CH11/LIA P8	CH12/LIA P8	CH13/LIA P8	CH14/LIA P8	CH15/LIA P8	CH16/LIA P8
240	CH17/LIA P8	CH18/LIA P8	CH19/LIA P8	CH20/LIA P8	CH21/LIA P8	CH22/LIA P8	CH23/LIA P8	CH24/LIA P8
248	CH25/LIA P8	CH26/LIA P8	CH27/LIA P8	CH28/LIA P8	CH29/LIA P8	CH30/LIA P8	CH31/LIA P8	CH32/LIA P8
256	CH1/LIA P9	CH2/LIA P9	CH3/LIA P9	CH4/LIA P9	CH5/LIA P9	CH6/LIA P9	CH7/LIA P9	CH8/LIA P9
264	CH9/LIA P9	CH10/LIA P9	CH11/LIA P9	CH12/LIA P9	CH13/LIA P9	CH14/LIA P9	CH15/LIA P9	CH16/LIA P9
272	CH17/LIA P9	CH18/LIA P9	CH19/LIA P9	CH20/LIA P9	CH21/LIA P9	CH22/LIA P9	CH23/LIA P9	CH24/LIA P9
280	CH25/LIA P9	CH26/LIA P9	CH27/LIA P9	CH28/LIA P9	CH29/LIA P9	CH30/LIA P9	CH31/LIA P9	CH32/LIA P9

RED: PLW channels BLUE: PSW channels
GREEN: PMW channels BLACK: T/C channels

2.3.5.3.3. DCU Spectrometer Full Array pixel arrangement

Index	0	1	2	3	4	5	6	7
0	CH1/LIA S1	CH2/LIA S1	CH3/LIA S1	CH4/LIA S1	CH5/LIA S1	CH6/LIA S1	CH7/LIA S1	CH8/LIA S1
8	CH9/LIA S1	CH10/LIA S1	CH11/LIA S1	CH12/LIA S1	CH13/LIA S1	CH14/LIA S1	CH15/LIA S1	CH16/LIA S1
16	CH17/LIA S1	CH18/LIA S1	CH19/LIA S1	CH20/LIA S1	CH21/LIA S1	CH22/LIA S1	CH23/LIA S1	CH24/LIA S1
24	CH1/LIA S2	CH2/LIA S2	CH3/LIA S2	CH4/LIA S2	CH5/LIA S2	CH6/LIA S2	CH7/LIA S2	CH8/LIA S2
32	CH9/LIA S2	CH10/LIA S2	CH11/LIA S2	CH12/LIA S2	CH13/LIA S2	CH14/LIA S2	CH15/LIA S2	CH16/LIA S2
40	CH17/LIA S2	CH18/LIA S2	CH19/LIA S2	CH20/LIA S2	CH21/LIA S2	CH22/LIA S2	CH23/LIA S2	CH24/LIA S2
48	CH1/LIA S3	CH2/LIA S3	CH3/LIA S3	CH4/LIA S3	CH5/LIA S3	CH6/LIA S3	CH7/LIA S3	CH8/LIA S3
56	CH9/LIA S3	CH10/LIA S3	CH11/LIA S3	CH12/LIA S3	CH13/LIA S3	CH14/LIA S3	CH15/LIA S3	CH16/LIA S3
64	CH17/LIA S3	CH18/LIA S3	CH19/LIA S3	CH20/LIA S3	CH21/LIA S3	CH22/LIA S3	CH23/LIA S3	CH24/LIA S3

RED: SLW channels BLUE: SSW channels

2.3.5.3.4. DCU Data Status Word

The last word of the data field has a specific meaning: it informs the DPU of occurrence of analog to digital converter latch-up or S/S to DPU interface fault and then of the risk to pack corrupted data. When a flag or more is set the related data of the current frame have to be discarded during on-ground data processing.

The meaning of this word depends on the data interface mode as shown below:

DCU Configuration	Frame Format	# of significant flags	Flags description
Photo. Array Subset	T1	1 to 3	bit 0 (LSB) = ADC1 latch-up flag bit 1 = ADC2 latch-up flag bit 2 = ADC2 latch-up flag bit 3 = ADC4 latch-up flag bit 4 = ADC5 latch-up flag bit 5 (MSB) = ADC6 latch-up flag
Spectro. Array Subset	T1	2 to 4	
Photo. Full Array	T2	6	
Spectro. Full Array	T2	6	
Test Pattern	T3	0	
Photo. Offset table	T2	0	
Spectro Offset table	T2	0	

Additionally in order to be able to reject data from the data format in both photometer and spectrometer mode ADC channel to LIA_P and LIA_S channel assignation has to be defined. The following table specify this assignation:

ADC channel	LIA_P channels	LIA_S channels
ADC1	LIA_P1 channels 1 to 16	LIA_S1 channels 1 to 12
	LIA_P1 channels 17 to 32	LIA_S1 channels 13 to 24
	LIA_P2 channels 1 to 16	LIA_S2 channels 1 to 12
ADC2	LIA_P2 channels 17 to 32	LIA_S2 channels 13 to 24
	LIA_P3 channels 1 to 16	LIA_S3 channels 1 to 12
	LIA_P3 channels 17 to 32	LIA_S3 channels 13 to 24
ADC3	LIA_P4 channels 1 to 16	LIA_S4 channels 1 to 12
	LIA_P4 channels 17 to 32	LIA_S4 channels 13 to 24
	LIA_P5 channels 1 to 16	LIA_S5 channels 1 to 12
ADC4	LIA_P5 channels 17 to 32	LIA_S5 channels 13 to 24
	LIA_P6 channels 1 to 16	LIA_S6 channels 1 to 12
	LIA_P6 channels 17 to 32	LIA_S6 channels 13 to 24
ADC5	LIA_P7 channels 1 to 16	LIA_S7 channels 1 to 12
	LIA_P7 channels 17 to 32	LIA_S7 channels 13 to 24
	LIA_P8 channels 1 to 16	LIA_S8 channels 1 to 12
ADC6	LIA_P8 channels 17 to 32	LIA_S8 channels 13 to 24
	LIA_P9 channels 1 to 16	LIA_S9 channels 1 to 13
	LIA_P9 channels 17 to 32	LIA_S9 channels 13 to 24

2.3.5.3.5. MCU Frame Definition

The four frame structures of the MCU are defined as follow:

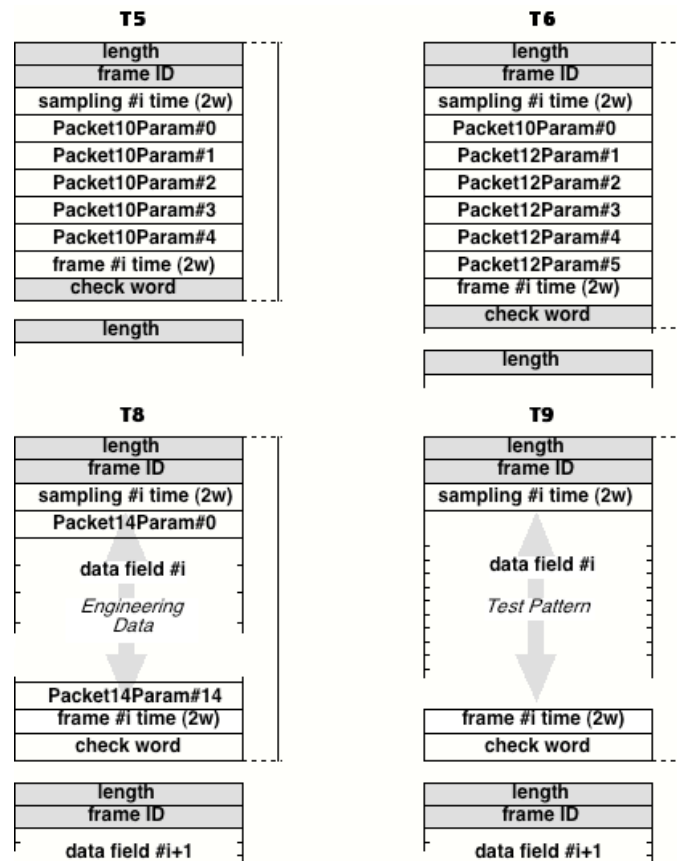

The following cross table shows the corresponding Frame ID for each MCU configuration status:

Configuration Status	Frame ID	Frame Format	Frame Length
SMEC	10	T5	12
BSM	12	T6	13
Engineering	14	T8	21
Test Pattern	15	T9	21

2.3.5.3.6. *MCU Data Field Description (frame ID 10)*

The following table defines the data field for a “SMEC” frame:

Index	Parameter Name	Default
0	Pack10Param#1	Optical Encoder Coarse Position
1	Pack10Param#2	Optical Encoder Fine Position
2	Pack10Param#3	LVDT Position
3	Pack10Param#4	Motor Setting Current (DAC)
4	Pack10Param#4	Motor BEMF value

2.3.5.3.7. *MCU Data Field Description (frame ID 12)*

The following table defines the data field for a “BSM” frame:

Index	Parameter Name	Default
0	Pack12Param#1	Chopper Magneto Resistive Sensor signal
1	Pack12Param#2	Chopper Motor Setting Current
2	Pack12Param#3	Chopper Motor Voltage (from ADC)
3	Pack12Param#4	Jiggle Motor Magneto Resistive sensor signal
4	Pack12Param#5	Jiggle Motor Setting Current
5	Pack12Param#6	Jiggle Motor Voltage (from ADC)

2.3.5.3.8. *MCU Data Field Description (frame ID 14)*

The following table defines the data field for an “Engineering” frame:

Index	Parameter Name	Default
0	Pack14Param#1	Encoder count
1	Pack14Param#2	SMEC Encoder signal 1 from ADC
2	Pack14Param#3	SMEC Encoder signal 2 from ADC
3	Pack14Param#4	SMEC Encoder signal 3 from ADC
4	Pack14Param#5	SMEC LVDT DC signal from ADC
5	Pack14Param#6	SMEC LVDT AC signal from ADC
6	Pack14Param#7	SMEC Motor Current from ADC
7	Pack14Param#8	SMEC Motor Voltage from ADC
8	Pack14Param#9	Chopper Magneto Resistor signal from ADC
9	Pack14Param#10	Chopper Motor Current from ADC
10	Pack14Param#11	Chopper Motor Voltage from ADC
11	Pack14Param#12	Jiggle Magneto Resistor signal from ADC
12	Pack14Param#13	Jiggle Motor Current from ADC
13	Pack14Param#14	jiggle Motor Voltage from ADC

2.3.5.3.9. MCU Data Field Description (frame ID 15)

The following table defines the data field for a “Test Pattern” frame:

Index	Data (hexa)
0	0x5555
1	0xAAAA
2	0x5554
3	0xAAA8
4	0x5550
5	0xAAA0
6	0x5541
7	0xAA82
8	0x5505
9	0xAA0A
10	0x5414
11	0xA828
12	5050
13	A0A0

2.3.5.3.10. SCU Frame Definition

The two frame structures of the SCU are defined as follow:

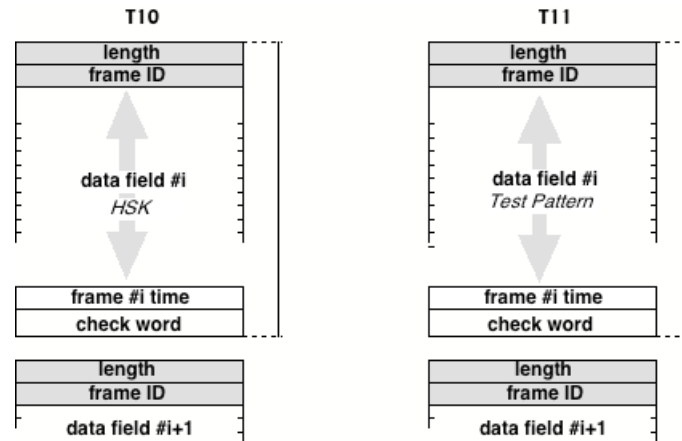

The following cross table shows the corresponding Frame Structure Type for each SCU configuration status:

Configuration Status	Frame Format	Frame ID	Frame Length
HSK	T10	20	30
Test Pattern	T11	21	30

2.3.5.3.11. SCU data field description (frame ID 20)

Index	Parameter Name	Description	ADC ID
0	T_CPHP	Cryo-cooler sorption Pump Heater temperature	TEMP
1	T_CPHS	Cryo- cooler sorption Pump Heat Switch temperature	TEMP
2	T_CEHS	Cryo-cooler Evaporator Heat Switch temperature	TEMP
3	T_CSHT	Cryo-cooler thermal SHunt temperature	TEMP
4	T_SOB	SPIRE Optical Bench temperature	TEMP
5	T_SL0	Spectrometer Level 0 (detector box) temperature	TEMP
6	T_PL0	Photometer Level 0 (detector box) temperature	TEMP
7	T_SUB	Optical SUB Bench temperature	TEMP
8	T_BAF	FPU input BAFfle temperature	TEMP
9	T_BSMS	BSM/Sob i/f temperature	TEMP
10	T_SCL2	Spectrometer CaLibrator 2% temperature	TEMP
11	T_SCL4	Spectrometer CaLibrator 4% temperature	TEMP
12	T_SCST	Spectrometer Calibrator flange (STructure) temperature	TEMP
13	T_FTSS	SMEC/Sob i/f temperature	TEMP
14	T_FTSM	SMEC Mechanism temperature	TEMP

15	T_BSMM	BSM Mechanism temperature	TEMP
16	T_CEV	Cryo-cooler EVaporator temperature	TEMP
17	PhCalCur	Bias current of Photometer Calibrator	CCHK
18	PhCalVolt	Voltage across Photometer Calibrator	CCHK
19	Scal2Cur	Bias current of Spectrometer Calibrator 4%	CCHK
20	Scal2Volt	Voltage across Spectrometer Calibrator 4%	CCHK
21	Scal4Cur	Bias current of Spectrometer Calibrator 2%	CCHK
22	Scal4Vol	Voltage across Spectrometer Calibrator 2%	CCHK
23	TCheaterVolt	Voltage across Thermal Control heater	CCHK

2.3.5.3.12. SCU data field description (frame ID 21)

Refer to § 2.3.6

2.3.5.3.13. SCU Data Status Word

The last word of the data field has a specific meaning: it informs the DPU of occurrence of analog to digital converter latch-up or S/S to DPU interface fault and then of the risk to pack corrupted data. When a flag or more is set the related data of the current frame have to be discarded during on-ground data processing.

The meaning of this word depends on the data interface mode.

See following table for details

SCU Configuration	FST	# of significant flags	Flags description
HSK	T8	2	bit 0 = CCHK ADC latch-up flag *
			bit 1 = TEMP ADC latch-up flag*
Test Pattern	T9	2	

Latch-up flag is active high.

2.3.5.4. Frame time

The “frame time” field follows the data structure area. It is a 32-bit word filled with the contents of the subsystem “time tag” counters. In order to keep data frame synchronisation for the 3 subsystems this counter is driven by a single clock signal and reset by a broadcast command. The clock is derived from the CLK line of the Command interface and the resolution is then 3.2 μ s. The full range of the counter is then above 13740 s (229 min); this means the DPU have to sent the reset command at least every 229 min in order to keep synchronisation between the 3 DRCU sub-systems.

The subsystem time counter shall be effectively reset within 10 μ s from the command reception and with a maximum skew between subsystems of 3 μ s.

2.3.5.5. Check word

The “check” word ends the data frame. Along with the “header” and “length” field it allows frame consistency checking. It is calculated by exclusive or of all frame words.

2.3.6. Test pattern

The purpose of this mode is to generate variable and predictable digital data for test and verification activities. Instead of transmitting a fixed pattern it implements a pseudo random generator based on a LFSR (see RD1).

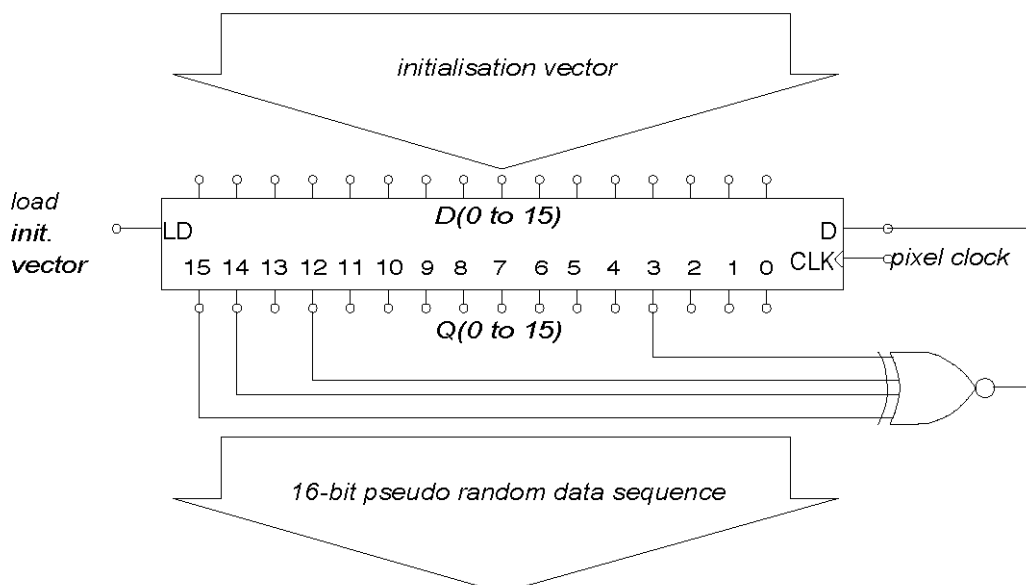

Figure 2.3-a LFSR functional description

When in test pattern mode the DRCU interface control logic substitutes the data with a pseudo-random sequence generated by a 16-bit linear feedback shift register (see RD2). The DRCU unit features 3 independent LFSR each corresponding to a data interface. Additionally each LFSR is initialised with a specific vector (V0) as show bellow:

V0	Subsystem Name	Comments
0102 hexa 0304 hexa 0405 hexa 0607 hexa 0809 hexa 0A0B hexa	DCU	For ADC1 test data For ADC2 test data For ADC3 test data For ADC4 test data For ADC5 test data For ADC6 test data
5555 hexa	MCU	
AAAA hexa*	SCU	Initilisation vector is loaded in register after a power-on or subsystem reset.

2.3.7. Interface Timing

The figure 2.3-b specifies the data interface timing.

Depending of the considered subsystem interface the data clock is:

Subsystem	Clock frequency
DCU	2.5 MHz
MCU	1.25 MHz
SCU	2.5 MHz

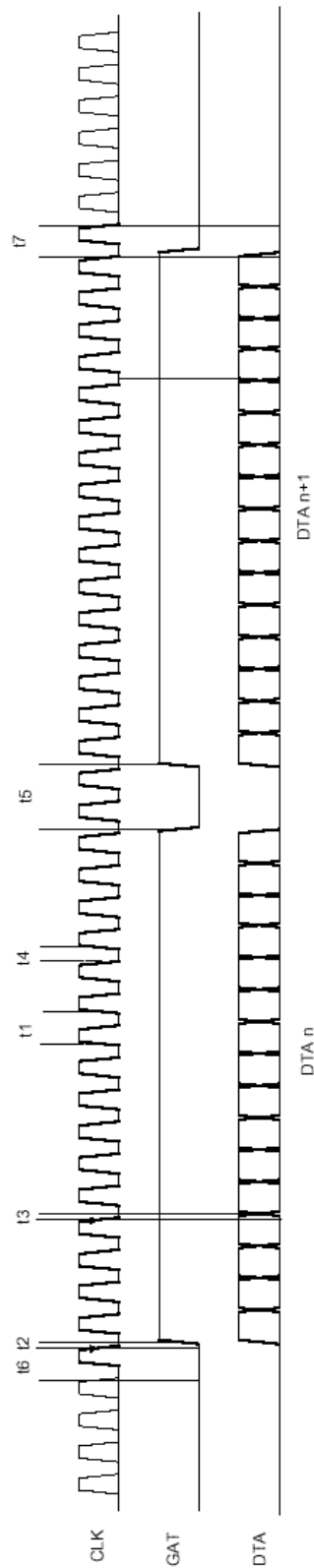

Symbol	Parameter	Min	Typ	Max	Unit
t1	clock period	396	-	1010	ns
t2	clk to gat delay	-30		50	ns
t3	clk to dat delay	-30		50	ns
t4	level "1" period	-10%	0.5 t1	+10%	ns
t5	gat to gat delay	2 t1			period
t6	clk active before gat	1 t1			period
t7	clk active after gat	1 t1			period

Fig 2.3-b Data Interface detailed Timing