

REFERENCE : H-P-1-ASPI-SP-0037

DATE : 18/02/2002

ISSUE : 2 REV : 2 Page : 1/67

TOTAL PAGES : 67



HERSCHEL / PLANCK

**EMC SPECIFICATION
H-P-1-ASPI-SP-0037**

Product Code : 000000

	Responsabilité – Service – Société Responsibility – Office - Company	Date	Signature
Rédigé par / Written by			
L. TROUGNOU	EMC engineering	18/02/2002	<i>L. Trougnou</i>
Vérifié par / Reviewed by			
K. HIBBERD	Electrical Engineering	18/2/02	<i>K. Hibberd</i>
P. COUZIN	Electrical Engineering	18/2/02	<i>P. Couzin</i>
Approuvé par / Approved by			
P. RIDEAU	System engineering	19/02/02	<i>P. Rideau</i>
C. MASSE	PA	19/02/02	<i>C. Masse</i>
Released by			
J.J. JUILLET	Project Manager	19/02/02	<i>J.J. Juillet</i>

Entité Emettrice : Alcatel Space - Cannes
(détentrice de l'original) :

ENREGISTREMENT DES EVOLUTIONS / CHANGE RECORDS

ISSUE	DATE	§ : DESCRIPTION DES EVOLUTIONS § : CHANGE RECORD	REDACTEUR AUTHOR
1	03/11/2000	Initial issue (FP-ASPI-RS-1003)	
2	23/07/2001	Update before SRR, mainly : <ul style="list-style-type: none"> • Update of RE requirements in agreement with ESA • Update of CE requirement for users on primary bus in agreement with ESA • Update of RS general requirement to be in line with IID-A (2 V/m instead of 1 V/m) • Update of CS DM requirement for users on primary bus to be consistent with IID-A (less stringent above 300 kHz) • Complete update of EMC requirements on signal lines • Change of LISN impedance • Suppression of ESD indirect (radiated) discharge 	
2/1	30/11/2001	Revision following SRR : <ul style="list-style-type: none"> • Page 11 : SRR RID SYS-21 (new wording agreed with ESA) • Page 18&21 : SRR RID SYS-20 (new H DC levels agreed with ESA) • Page 19 : SRR RID SYS-22 (typing) • Page 22 : SRR RID AIV-29 (ESD, agreed with ESA) • Page 23 : SRR RID SVM-112 (PCDU step load transients) • Page 30 : SRR RIDs SVM-110, SVM-113 (PCDU CS) • Page 42 : SRR RID SVM-113 (PCDU CS) • Page 47 : SRR RID SVM-113 (PCDU CS) <p>Introduction of plug-in specification.</p> <p>Introduction of notch in HIFI IF band in RE requirement for Herschel.</p>	
2/2	18/02/2002	<ul style="list-style-type: none"> • Numbering of requirements and corresponding minor wording updates ; • § 3.2.3.1 (SVM requirements) updated for consistency with the EMC Control Plan • § 3.2.4.6.1.1.1 : note added ; • § 3.2.4.6.1.2.1 : conditional relaxation of RE H field DC requirement (back to issue: 2/0 level 106 dBpT if distance to next unit > 12 cm) ; • § 3.2.4.8.1.2 : PCDU step load transient mask updated ; • § 3.4.2.8.3 (CS of PCDU output power lines) : updated text agreed with Alenia (H-P-ASPI-MN-909) ; • § 3.2.4.8.4.2.1 : CS transient DM rise time changed from "10 to 100 μs" to "10 μs". 	

TABLE OF CONTENTS

1. SCOPE.....	4
1.1 PURPOSE	4
1.2 APPLICABILITY.....	4
2. DOCUMENTS	5
2.1 Applicable documents	5
2.2 Reference documents.....	5
3. REQUIREMENTS	6
3.1 HERSCHEL/PLANCK SPACECRAFT REQUIREMENTS	6
3.1.1 General	6
3.1.2 EMC with ground environment	6
3.1.3 EMC with the launch system	6
3.1.4 EMC with flight environment	10
3.2 Spacecraft TESTING REQUIREMENTS	11
3.2.1 General	11
3.2.2 Spacecraft internal EMC	11
3.2.3 Module EMC	15
3.2.4 Subsystem and equipment requirements	18
4. SPACECRAFT TESTING CONDITIONS REQUIREMENTS	47
4.1 TESTING FACILITIES.....	47
4.2 SPACECRAFT OPERATIONAL CONFIGURATION	47
4.3 RADIATED EMISSION	47
4.4 SUSCEPTIBILITY TESTING	47
5. MODULE TESTING CONDITIONS REQUIREMENTS	48
5.1 PAYLOAD MODULE CONDITIONS	48
5.2 SERVICE MODULE CONDITIONS.....	48
6. EQUIPMENT/SUBSYSTEM TESTING CONDITIONS.....	49
6.1 TEST SET-UP REQUIREMENTS	49
6.1.1 General test set-up requirements	49
6.1.2 Test set-up for emission measurement	51
6.1.3 Test set-up for susceptibility tests	55
6.2 TEST GUIDELINES	63
6.2.1 Accessory equipment precaution	63
6.2.2 Excess personnel and equipment	63
6.2.3 Use of measuring equipment	63
6.2.4 Identification of spurious responses in measuring equipment	63
6.3 TEST EQUIPMENT	63
6.3.1 Ground plane	63
6.3.2 Tolerance of test parameters	64
6.3.3 Suggested test antennas	65
7. ABBREVIATIONS	67

1. SCOPE

1.1 PURPOSE

This specification defines the requirements applicable to the HERSCHEL & PLANCK spacecraft's as far as the various electromagnetic compatibility aspects are concerned.

It further defines tests levels and methods which have to be applied in the course of testing.

The cross reference between needs i.e. test and verifications necessary to fulfil the requirements is given in the EMC/ESD control plan.

1.2 APPLICABILITY

This specification will cover the following areas :

- EMC with ground environment (EGSE, MGSE,...)
- EMC with launcher environment
- EMC with the flight environment encountered in orbit
- Internal spacecraft EMC including EMC at sublevels
 - module EMC (Payload and Service module)
 - subsystem and equipment EMC.

2. DOCUMENTS

2.1 Applicable documents

The following documents form a part of this specification, to the extent specified in the text of this specification.

AD-01.1 : First/Planck System Requirements Specification (SRS)

SCI-PT-RS-05991

AD-04.1 : IID Part A

SCI-PT-IIDA-04624

AD-04.2 : IID Part B, Bolometer Instrument

SCI-PT-IIDB/SPIRE-02124

AD-04.3 : IID Part B, Heterodyne Instrument

SCI-PT-IIDB/HIFI-02125

AD-04.4 : IID Part B, Photoconductor Instrument

SCI-PT-IIDB/PACS-02126

AD-04.5 : IID Part B, HFI

SCI-PT-IIDB/HFI-04141

AD-04.6 : IID Part B, LFI

SCI-PT-IIDB/HFI-04142

AD-06.1 : Ariane 5 user manual

Issue 3/Rev. 00 - March 2000

2.2 Reference documents

- General Design and Interface Requirements
H-P-1-ASPI-SP-0027
- EMC/ESD Control Plan
H-P-1-ASPI-PL-0038
- **PCDU Specification**
H-P-SP-AI-0014
- ESA standard on « Electromagnetic Compatibility Requirements for Space Systems », SPS/Std/1/002, issue 1, Oct. 1980.
- US, DOD Military Standard on « Electromagnetic Emission and Susceptibility Requirements for the Control Electromagnetic interference », MIL-STD-461E, 20 August 1999.
- US, DOD Military Standard : « Aircraft Internal Time Division Command/Response Multiplex Data Bus », MIL-STD-1553B, 21 September 1978

3. REQUIREMENTS

3.1 HERSCHEL/PLANCK SPACECRAFT REQUIREMENTS

3.1.1 General

Requirement EMCSYS-000

Throughout the spacecraft lifetime, from equipment integration until spacecraft decommissioning, the spacecraft or parts thereof shall neither cause disturbances to other systems, nor suffer loss of performance due to other systems or to the orbit environment.

Requirement EMCSYS-010

The ability of the spacecraft to perform its mission with the required performances will be demonstrated by test, analysis or similarity.

3.1.2 EMC with ground environment

Requirement EMCSYS-020

The EGSE and MGSE used for spacecraft integration and ground testing shall be designed in order to meet the EMC required by the spacecraft.

3.1.3 EMC with the launch system

Requirement EMCSYS-030

The EMC requirements to be fulfilled by the spacecraft during the prelaunch and launch phases are described in the ARIANE 5 user manual.

These requirements are reproduced hereafter for information.

3.1.3.1 Radiation from the launch vehicle

3.1.3.1.1 Launcher

The launch vehicle is equipped with the following transmission and reception systems :

- A telemetry system comprising two transmitters, each one coupled with a system of two antennae having an omnidirectional radiation pattern and respectively right and left-handed polarisation. One transmitter is located in the VEB with its antennae fitted in the external section of the VEB. The second transmitter is located in the forward skirt of the cryogenic core stage with its antennae fitted on external part of skirt.

The transmission frequency is in the 2200 – 2290 MHz band, and the transmitter power is 8 W.

Allocated frequencies to the Launch Vehicle are: 2206.5 MHz, 2227 MHz and 2254.5 MHz, 2267.5 MHz, 2284 MHz.

- A telecommand-destruct reception system, comprising two receivers operating in the 440 – 460 MHz band. Each receiver is coupled to a system of two antennae, located on the cryogenic core stage, having an omnidirectional pattern and no special polarisation.
- A radar transponder system, comprising two identical transponders with a reception frequency of 5690 MHz, and transmission frequencies in the 5400 – 5900 MHz band.

The minimum pulsed (0.8 μ s) transmitting power of each transponder is 400 W peak. Each transponder is coupled to a system of two antennae, located on the cryogenic core stage, with an omnidirectional pattern and clockwise circular polarisation.

Radiated levels (spurious or intentional) from the launch vehicle do not exceed those given in figure 3.1.3.1-1 : spurious radiation : narrow-band electrical field.

These levels are measured at 1 m below the 2624 reference bolted interface.

3.1.3.1.2 Range

The range electromagnetic environment of the CSG is measured every 18 months.

Spurious radiation interference levels from the launch vehicle and the CSG will not exceed those given in figure 3.1.3.1-1 : spurious radiation : narrow-band electrical field.

These levels are measured at 1 m below the 2624 reference bolted interface.

Specific spurious radiations, emanating from the launch vehicle transmission systems, in particular from telemetry system, are lower than these levels (harmonics included).

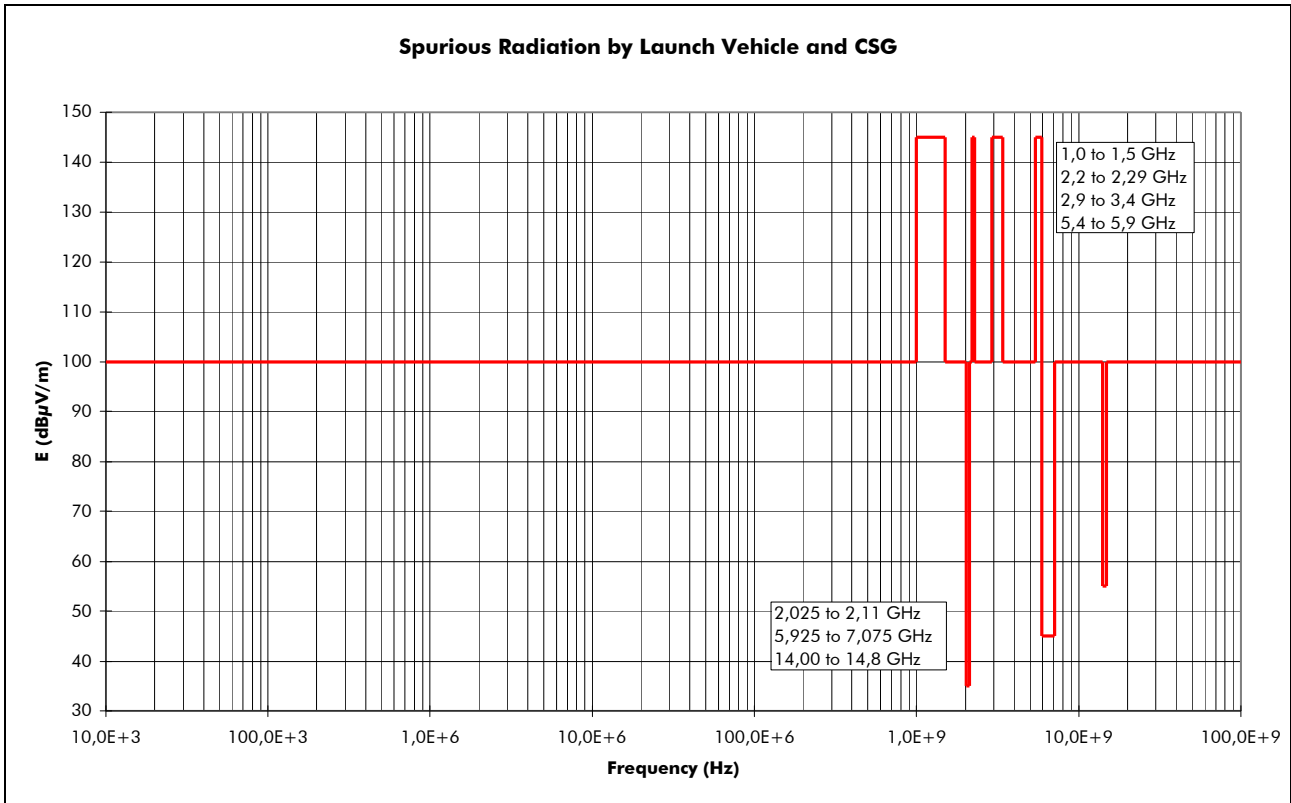

Figure 3.1.3.1-1 : Spurious radiation by launch vehicle and CSG : narrow-band electrical field

3.1.3.2 Spurious radiation from spacecraft

- The spacecraft shall not radiate a narrow-band electrical field at the level of the VEB exceeding the limit set in figure 3.1.3.2-1 (including intentional transmission).
- A 35 dB μ V/m level radiated by the spacecraft, in the launch vehicle telecommand receiver 420 – 480 MHz band, shall be considered as the worst case of the sum of spurious level over 300 kHz bandwidth.

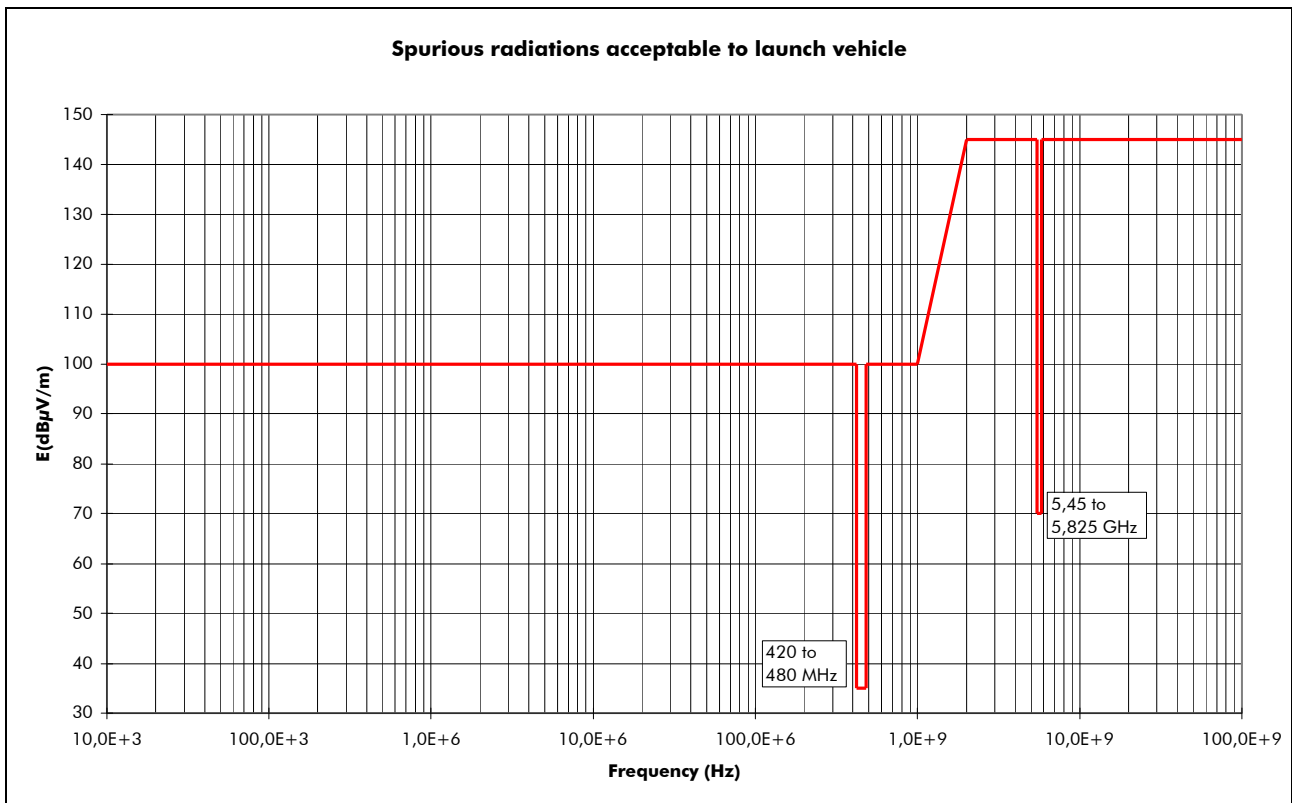

Figure 3.1.3.2-1 : Spurious radiation acceptable to launch vehicle

3.1.4 EMC with flight environment

The spacecraft shall fulfil the requirements imposed by the environment during all orbital phases.

Differential charging, occurrence of electrical discharge and degrading effects upon spacecraft nominal performances shall be minimised with the objective to prevent them via design.

The corresponding design requirements are specified in GDIR § 6.

3.2 Spacecraft TESTING REQUIREMENTS

3.2.1 General

Requirement EMCSYS-040

The ability of the spacecraft to perform its mission with the required performance shall be demonstrated. Particularly, a sufficient margin (> 6 dB) shall be demonstrated between Emission & Susceptibility.

3.2.2 Spacecraft internal EMC

3.2.2.1 Radiated emission

3.2.2.1.1 Compliance with the LV requirements

Requirement EMCSYS-050

In the VEB plane, narrowband E-field emission will be measured, using standard calibrated antennae and shall not exceed of the limits given in figure 3.1.3.2 - 1.

Requirement EMCSYS-052

Measurements shall be made in the UHF and C-band notches.

Requirement EMCSYS-055

For this test the spacecraft shall be in launch configuration and the measurement shall be made in the 2 conditions :

- Spacecraft powered by external power supply (prelaunch)
 - Spacecraft powered by internal battery (launch)
-

3.2.2.1.2 PLM environment

3.2.2.1.2.1 Herschel :

Requirement EMCSYS-060

At 3 different points (TBC) around the cryostat (mainly oriented to each Instrument FPU/harness direction), the narrow band E-field emission shall be measured in the frequency range 14 kHz – 18 GHz. Such measurements shall be used to determine the compatibility of the overall platform with the Instruments.

3.2.2.1.2.2 Planck :

Requirement EMCSYS-065

At 2 different points (TBC) around PPLM, the narrow band E-field emission shall be measured in the frequency range 14 kHz – 18 GHz. Such measurements shall be used to determine the compatibility of the overall platform with the Instruments.

3.2.2.2 Radiated susceptibility

3.2.2.2.1 E-field

Requirement EMCSYS-070

Over the frequency range 14 kHz to 18 GHz, the HERSCHEL and PLANCK spacecraft's shall not exhibit any malfunction, degradation of performance when subjected to sinewave E-field, the level and characteristics are given in § 3.2.4.6.2 (identical to unit/Payload levels).

3.2.2.2.2 H-field

Requirement EMCSYS-075

Over the frequency range 30 Hz to 50 kHz, the HERSCHEL and PLANCK spacecraft's shall not exhibit any malfunction, degradation of performance when subjected to sinewave H-field, the levels are given in § 3.2.4.6.2 (identical to unit/Payload levels).

3.2.2.2.3 Test conditions

3.2.2.2.3.1 Herschel :

Requirement EMCSYS-080

Three directions (TBC), mainly oriented to each Instrument FPU/harness direction, shall be used for susceptibility threshold determination. A number TBD of payload configurations shall be tested.

3.2.2.2.3.2 Planck :

Requirement EMCSYS-085

Two directions (TBC) shall be used for susceptibility threshold determination. A number TBD of payload configurations shall be tested.

3.2.2.3 Conducted Emission

Requirement EMCSYS-090

CE measurements shall be confined to those areas not already tested at sublevel (module/subsystem) or for which configurations were not fully representative.

Requirement EMCSYS-092

On the Primary power lines (28 V lines) between PCDU and Instruments warm units, the following two types of measurements shall be performed :

- Current spectral analysis on a 30 Hz – 50 MHz frequency range in both differential and common mode
 - RMS noise measurement on a 10 MHz frequency bandwidth (measured with RMS voltmeter or digital oscilloscope capable to compute it).
-

Requirement EMCSYS-094

Should any CE measurement exceed the corresponding one at sublevel, an analysis shall be run in order to assess whether the System margin becomes uncertain or not. The approach shall be defined in agreement with ESA and may result in the decision to perform exceptional CS testing at system level.

Requirement EMCSYS-096

CE measurements on TBD links between Service Module and Payload Module shall be performed.

Requirement EMCSYS-098

The voltage ripple between the SVM and PLM structures shall be measured :
Cryostat structure for Herschel / groove 3 structure for Planck (TBC).

3.2.3 Module EMC

3.2.3.1 Service Module requirements

Requirement EMCSVM-000

The Conducted EMC tests at SVM level shall be performed on the AVM, in HERSCHEL configuration and in PLANCK configuration. The CE tests shall be repeated at PFM level as defined in the EMC Control Plan.

The Service Module AVM is understood to be composed of the Service AVM units/subsystems and of the Instrument Warm Units.

3.2.3.1.1 Conducted emission

Requirement EMCSVM-005

CE on Service Module shall be made using calibrated probes, in areas not already tested at unit/subsystem level or for which unit/subsystem EMC test configuration were not fully flight representative.

Requirement EMCSVM-010

On the Primary power lines (28 V lines) between PCDU and Service Module users, the following two types of measurements shall be performed :

- Current spectral analysis on a 30 Hz – 50 MHz frequency range in both differential and common mode
- RMS noise measurement on a 10 MHz frequency bandwidth (measured with RMS voltmeter or digital oscilloscope capable to compute it).

Requirement EMCSVM-020

CE measurements shall be performed on inter subsystem TBD links.

Requirement EMCSVM-030

CE measurements identified as being marginal during unit/subsystem testing shall be repeated at SVM level.

3.2.3.1.2 Conducted susceptibility

Requirement EMCSVM-040

On the SVM AVM including the Instruments Warm Units, after the CE measurements on the power lines at PCDU output, CE + (> 6 dB) shall be injected (CS) on the output of PCDU in order to demonstrate the system margin, in both differential and common modes.

3.2.3.2 HERSCHEL/PLANCK Payload Module requirements

The Payload module is understood to be composed of the cold payload (Herschel cryostat or Planck telescope with FPU's) and of the Instrument Warm Units.

3.2.3.2.1 Conducted emission

A. On primary power lines (28 V lines)

Requirement EMCPLM-000

On each Payload Module units receiving primary power, the CE towards Service Module shall be measured in the frequency range 30 Hz to 50 MHz. This shall be a spectrum analyser measurement (NB).

B. On secondary power lines

Requirement EMCPLM-010

Conducted emission (spectral analysis of using NB BW) shall be measured on the instruments preamps and detector secondary power lines at the source end (details will be part of the dedicated test procedures).

Measurements shall be made in differential mode and common mode in the frequency range from 30 Hz to 50 MHz.

3.2.3.2.2 Conducted susceptibility

Requirement EMCPLM-020

For each payload configuration, the Payload module shall not exhibit degradation of performance when subject to the following parasitic signals on power lines (28 V).

- Differential mode
 - sinewave
 - transients
- Common mode
 - sinewave
 - transients

Levels and frequency range shall be those used at unit level (as per § 3.2.4.8.4).

3.2.3.2.3 Radiated susceptibility

Requirement EMCPLM-030

One of the following susceptibility tests shall be performed at Payload Module level :

- CS simulating RS on the cold harness on SVM side, with a level to be defined based on the RS specification (2 V/m from 14 kHz up to the maximum achievable limit) and on a worst case field to cable coupling analysis ;
 - Standard RS (2V/m from 14 kHz up to 18 GHz), cf. 3.2.4.6.2.1/2.
-

Requirement EMCPLM-040

Susceptibility tests at Payload Module level shall be performed with detectors in cold conditions and shall include success criteria based on detection noise.

3.2.4 Subsystem and equipment requirements

3.2.4.1 General

Each equipment or subsystem shall be considered as a part of whole system whose operation depends on the performance of each component.

Consequently, each equipment, subsystem or group of subsystems under the responsibility of subcontractor or Instrument supplier shall be designed in order to achieve the EMC with the other equipment, subsystems and Instruments in the various operating modes.

Requirement EMCEQ-000

The requirements stated in the present paragraph 3.2.4 are applicable for unit **and** subsystem levels : see EMC/ESD control plan (H-P-1-ASPI-PL-0038).

Requirement EMCEQ-010

The subsystem responsible will be allowed to use the test results at equipment (or group of equipment) level to demonstrate the EMC of its subsystem with the requirements. In this way, the duplication of identical measurements will be avoided. However, this does not mean that no EMC test have to be performed at subsystem level. As a minimum, it is required that a self-compatibility test is performed at subsystem level to prove the EMC.

Requirement EMCEQ-020

The various equipment will be linked by the same type of wires as those used at spacecraft level (length, shielding, and as far as possible, layout).

Requirement EMCEQ-030

EMC tests at equipment level shall be performed before EMC tests at subsystem level.

Requirement EMCEQ-040

Compliance with this specification shall be demonstrated by the subcontract by tests, and/or by analysis.

Requirement EMCEQ-045

The choice of the analysis method shall be subject to PRIME approval and shall be supported by justification.

3.2.4.2 Qualification philosophy

Requirement EMCEQ-050

EMC qualification shall be achieved on flight equivalent units.

It is strongly recommended that the first prototypes or breadboards are tested well in advance of the qualification test on flight representative units in order to identify the potential problems and to assess the EMC performance of the unit.

3.2.4.3 Documentation

Requirement EMCEQ-060

EMC test procedures for unit/subsystem tests shall be produced and shall :

- describe the different operating modes of the equipment or subsystem
 - define for each kind of test (CE, CS, RE, RS), the different modes tested and corresponding test configuration which have to be chosen to be as far as possible representative of the system configuration (including interconnecting cables).
 - define the susceptibility criteria and the way of monitoring (test methods)
 - define in detail the test set-up (including the measurement accuracy).
 - define the test acceptance criteria
-

3.2.4.4 Bandwidths

Requirement EMCEQ-070

The measurement receiver bandwidths listed below shall be used for emission testing. These bandwidths are specified at the 6 dB down points for the overall selectivity curve of the receivers.

Frequency range	Maximum 6 dB Bandwidth
30 Hz – 1 kHz	10 Hz
1 kHz – 10 kHz	100 Hz
10 kHz – 150 kHz	1 kHz
150 kHz – 30 MHz	10 kHz
30 MHz – 1 GHz	100 kHz
Above 1 GHz	1 MHz

Requirement EMCEQ-080

Video filtering shall not be used to bandwidth limit the receiver response. If a controlled video bandwidth is available on the measurement receiver, it shall be set to its greatest value.

It is understood that the bandwidth values are measuring equipment dependant. Any deviation the above shall be approved by the Prime before being adopted.

3.2.4.5 Amplitude

All the levels given in following requirements are r.m.s. amplitude unless otherwise mentioned.

3.2.4.6 Radiation requirements

3.2.4.6.1 Radiation emission (RE)

3.2.4.6.1.1 Radiated Emission E-field

3.2.4.6.1.1.1 General requirement

Requirement EMCEQ-100

In the 14 kHz – 18 GHz, the electrical field emitted by unit under test, including intentional and unintentional radiation from the test harness, shall be less than the hereafter defined limit:

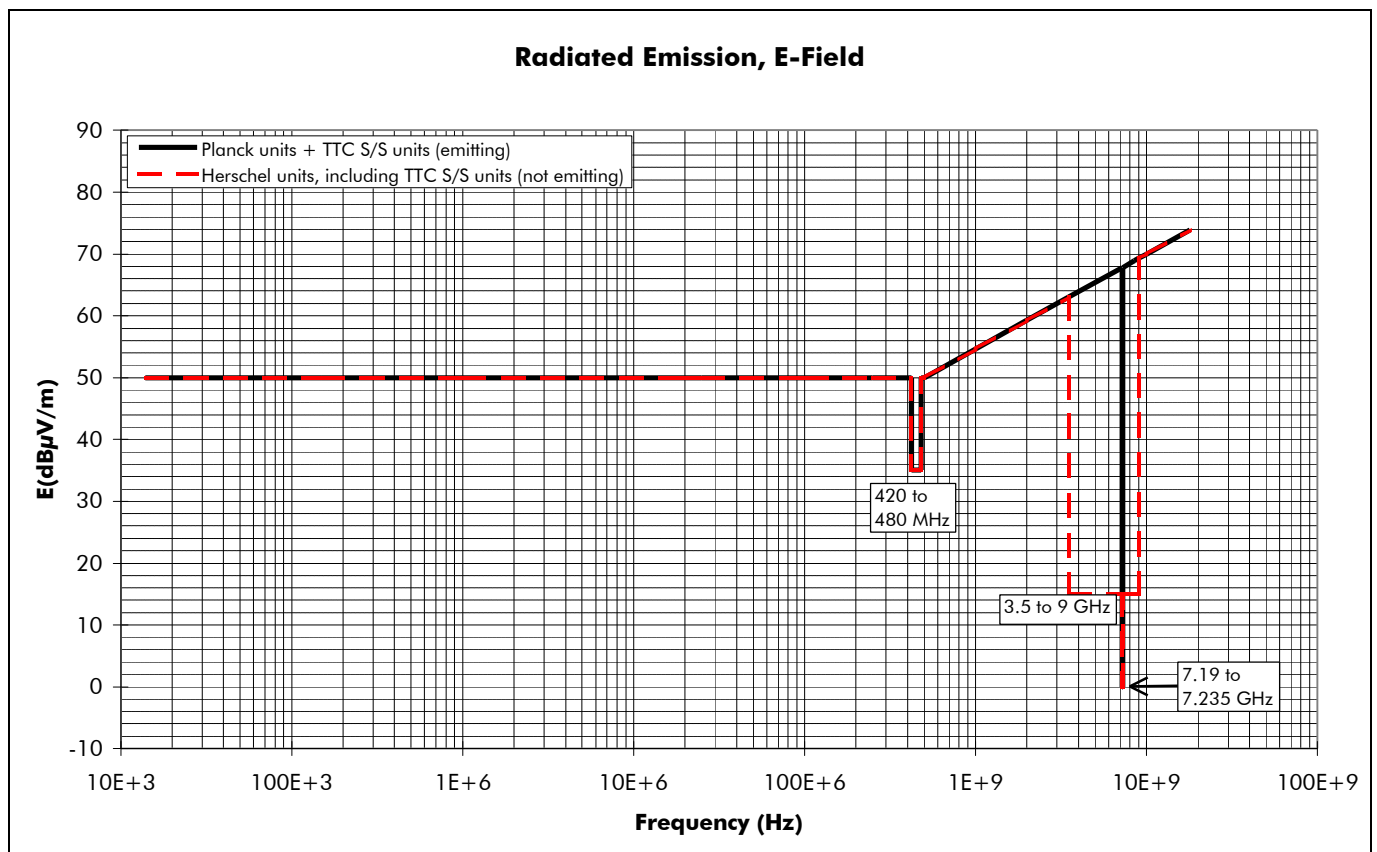

Figure 3.2.4.6-1 :Radiated emission E-field, NB

The notch in the frequency range 420 – 480 MHz is applicable only to units operating during launch.

The [3.5 - 9] GHz notch will be confirmed after precise knowledge of the TTC receivers LO frequencies.

3.2.4.6.1.1.2 Test method

Requirement EMCEQ-120

The measurement shall be performed at 1 meter distance from the unit under test.

Requirement EMCEQ-130

Both vertical and horizontal polarisation of the test antenna shall be used for frequencies higher than 30 MHz, except if this antenna is circularly polarised.

Requirement EMCEQ-140

The upper frequency range of measurement shall be in accordance with the following tables (TBC).

Herschel :

Tenth harmonic of highest operating frequency of equipment	Required upper limit
< 1 GHz	1 GHz
> 1 GHz	18 GHz

Planck :

Tenth harmonic of highest operating frequency of equipment	Required upper limit
< 1 GHz	1 GHz
1 - 18 GHz	18 GHz
> 18 GHz	40 GHz

3.2.4.6.1.2 Radiated Emission H-field

3.2.4.6.1.2.1 DC requirement

Requirement EMCEQ-150

The following DC H field limit is defined for the unit under test fitted with its test harness and powered on :

- 106 (TBC) dBpT at 1 meter i.e. 200 nT provided that the closest unit is at a minimum 12 cm distance ;
 - 94 dBpT at 1 meter i.e. 50 nT otherwise.
-

Requirement EMCEQ-160

That requirement is applicable at subsystem and unit level. Opportunity shall be taken, as far as feasible of test at equipment level to demonstrate the compliance at S/S level taking account the spacecraft layout in all the operating modes.

Requirement EMCEQ-170

The specified level shall be verified either by test (in accordance with the procedure steps listed in § 6.1.2.4.) or by analysis (taking into account magnetic materials and DC current loops for the minimum).

3.2.4.6.1.2.2 Narrowband H-field emission

Requirement EMCEQ-180

In the 30 Hz – 50 kHz frequency range, the magnetic field radiated by the unit under test (including intentional and unintentional radiation from the test harness) shall not exceed 60 dBpT, at 1 m distance.

The test is applicable at unit/subsystem level.

3.2.4.6.2 Radiated susceptibility (RS)

3.2.4.6.2.1 Radiated susceptibility, E-field

Requirement EMCEQ-200

Over the frequency range 14 kHz to 18 GHz, see figure 3.2.4.6.2.1-1, the unit/subsystem fitted with its test harness shall not exhibit any malfunction, degradation of performance or deviation from specified susceptibility criteria given by the corresponding subsystem specification and test procedure when subjected to sinewave E-field of :

- 2 V/m in the whole frequency range
- 18 V/m from 1,0 GHz to 1,5 GHz (launch pad requirement) *
- 18 V/m from 2,2 GHz to 2,29 GHz (launcher TM) *
- 18 V/m from 2,9 GHz to 3,4 GHz (launch pad requirement) *
- 18 V/m from 5,4 GHz to 5,9 GHz (launcher/ground radar) *
- 10 V/m from 8,45 GHz to 8,5 GHz (spacecraft TM)

(*) Valid only for equipment operating during launch and for RF receivers.

Requirement EMCEQ-210

The sweep speed for the test shall not be faster than 1 octave/minute

Requirement EMCEQ-220

The sinewave signal shall be 30% amplitude modulated by 1 kHz squarewave (other amplitude modulation characteristics may be accepted by the Prime, but shall be proposed for approval prior to testing).

Requirement EMCEQ-230

Above 30 MHz, the requirements shall be met for both horizontally and vertically polarised waves.

Requirement EMCEQ-240

The test shall be performed as per MIL.STD.462 (RS03).

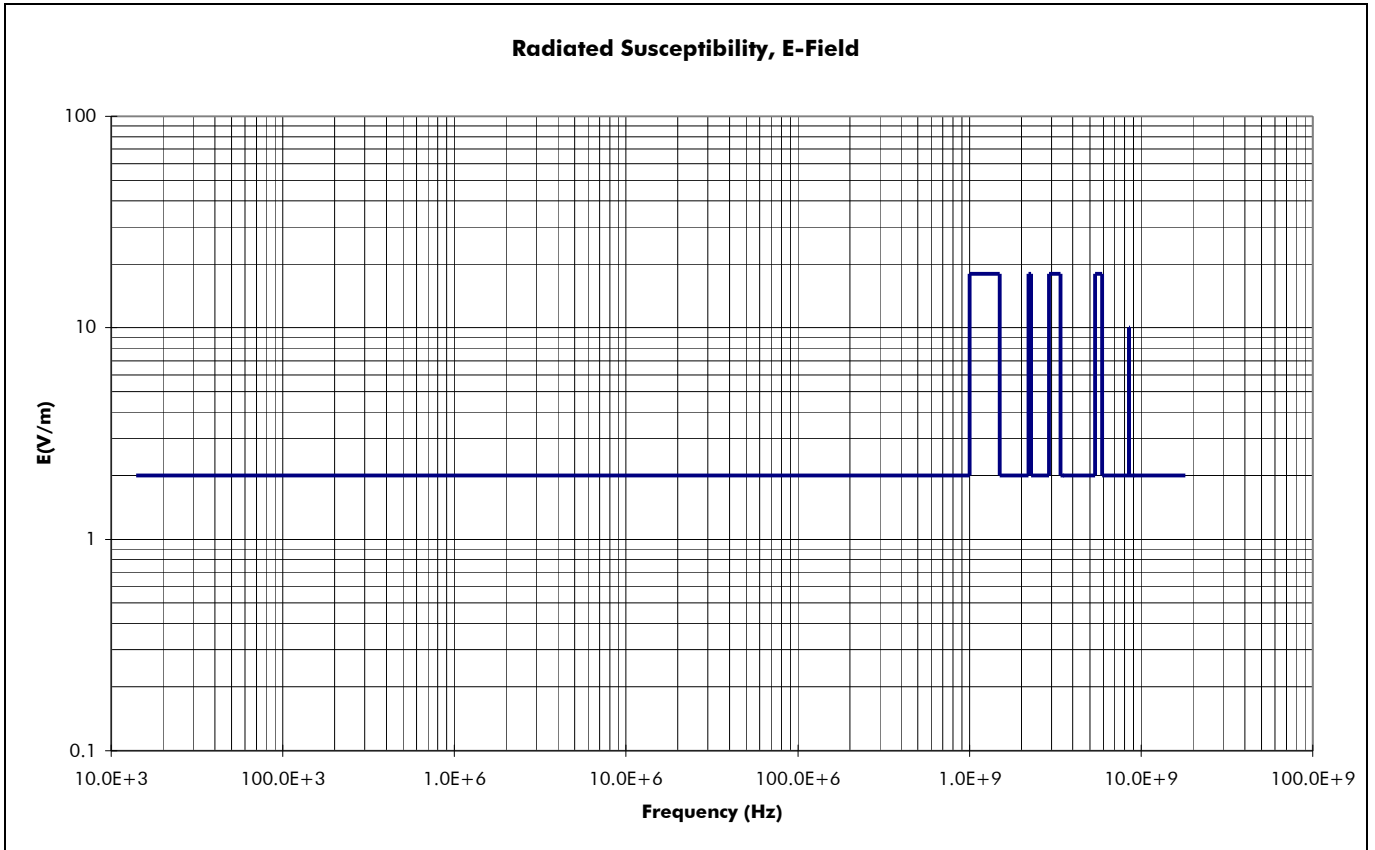

Figure 3.2.4.6.2.1-1: Radiated susceptibility E-field

3.2.4.6.2.2 Radiated susceptibility, H-field

3.2.4.6.2.2.1 Radiated susceptibility, H-field, sinus

Requirement EMCEQ-250

Over the frequency range 30 Hz to 50 kHz, the unit under test, fitted with its test harness, shall not exhibit any malfunction, degradation of performance, or deviation from specified susceptibility criteria given by the corresponding subsystem specification and test procedures, when subjected to sinewave magnetic field of 140 dBpT.

Requirement EMCEQ-260

Should it be impossible to reach a uniform H Field at the unit location ("big" unit/subsystem), the test shall be done by moving the antenna around the unit under test.

Requirement EMCEQ-270

The sweep speed of the test shall not be faster than 1 octave/minute.

3.2.4.6.2.2.2 Radiated susceptibility, H-field, DC :

Requirement EMCEQ-280

The unit under test, fitted with its test harness, shall not exhibit any malfunction, degradation of performance, or deviation from specified susceptibility criteria given by the corresponding subsystem specification and test procedures, when subjected to DC magnetic field of :

160 dBpT (TBC), (0.1 m Tesla or 1 Gauss)

3.2.4.7 Susceptibility to ESD

Requirement EMCEQ-300

The unit (or group of units or subsystems) under test fitted with its test harness (representative of the flight conditions) shall not exhibit any permanent malfunction, degradation of performance, or deviation from specified indication beyond tolerances indicated in the corresponding subsystem/unit specification when subjected to the following :

Conducted discharges into the equipment structure and in the ground plane under cables :

- Voltage : 15 kV
 - Peak current : 50 A typical
 - Energy : 15 mJ
 - Current risetime : ≤ 10 ns
 - Duration : 50 ns typical
-

Requirement EMCEQ-310

During the ESD tests, the unit shall be mounted on a metallic ground plane with the same conditions of bonding and grounding as used in the spacecraft and shall be fully powered.

Requirement EMCEQ-320

The two injection points shall be the most distant points of the unit structure where electrical connection is feasible (mounting hole, bonding point, connector, cover screw...).

Requirement EMCEQ-330

A minimum of 20 discharges shall be implemented with a minimum repetition rate of 10 seconds.

Requirement EMCEQ-340

This test is not to be performed on flight equipment.

3.2.4.8 Conduction requirements (power lines)

3.2.4.8.1 Conduction requirements on PCDU output power lines

The following requirements are applicable to the PCDU and to the Electrical Power Subsystem.

3.2.4.8.1.1 Broadband emission (differential mode)

Requirement EMCPCDU-000

The conducted emission on the PCDU output power lines shall be less than :

- 300 mV_{pp}
- 50 mV_{rms}

Those figures are valid whatever the operating mode.

The peak to peak value (including ripple and spikes) shall be measured with an oscilloscope, capable to detect peak to peak value, with an adequate bandwidth (≥ 50 MHz).

The RMS value (including ripple and spikes) shall be measured with a true RMS voltmeter up to 10 MHz, or with a digital oscilloscope capable to compute it.

3.2.4.8.1.2 Transient single event (differential mode)

Note : the step load voltage transients and interdomain voltage transients at the regulation point are specified in the PCDU specification.

Requirement EMCPCDU-010

The PCDU shall be connected to typical equipment loads with all the loads corresponding to the nominal Users configuration achieving the maximum consumption.

Requirement EMCPCDU-020

The LCL output providing the maximum current to a single equipment shall be selected.

Requirement EMCPCDU-030

The voltage transient on the LCL output of interest and on other LCL's output shall be measured when the equipment (equivalent load) switch is opened and closed.

Requirement EMCPCDU-040

The voltage transient shall be contained within the envelopes given in figure 3.2.4.8.1.2-1 (TBC).

Requirement EMCPCDU-050

Transient occurrence conditions (load variation law) for test purpose shall be :

- step of load $I = \pm 10 A_{peak}$ (28V)

- current rate of change di/dt (imposed by the load) : 10^6 A/s shall be tested.

Requirement EMCPCDU-060

Both step of load polarities shall be tested.

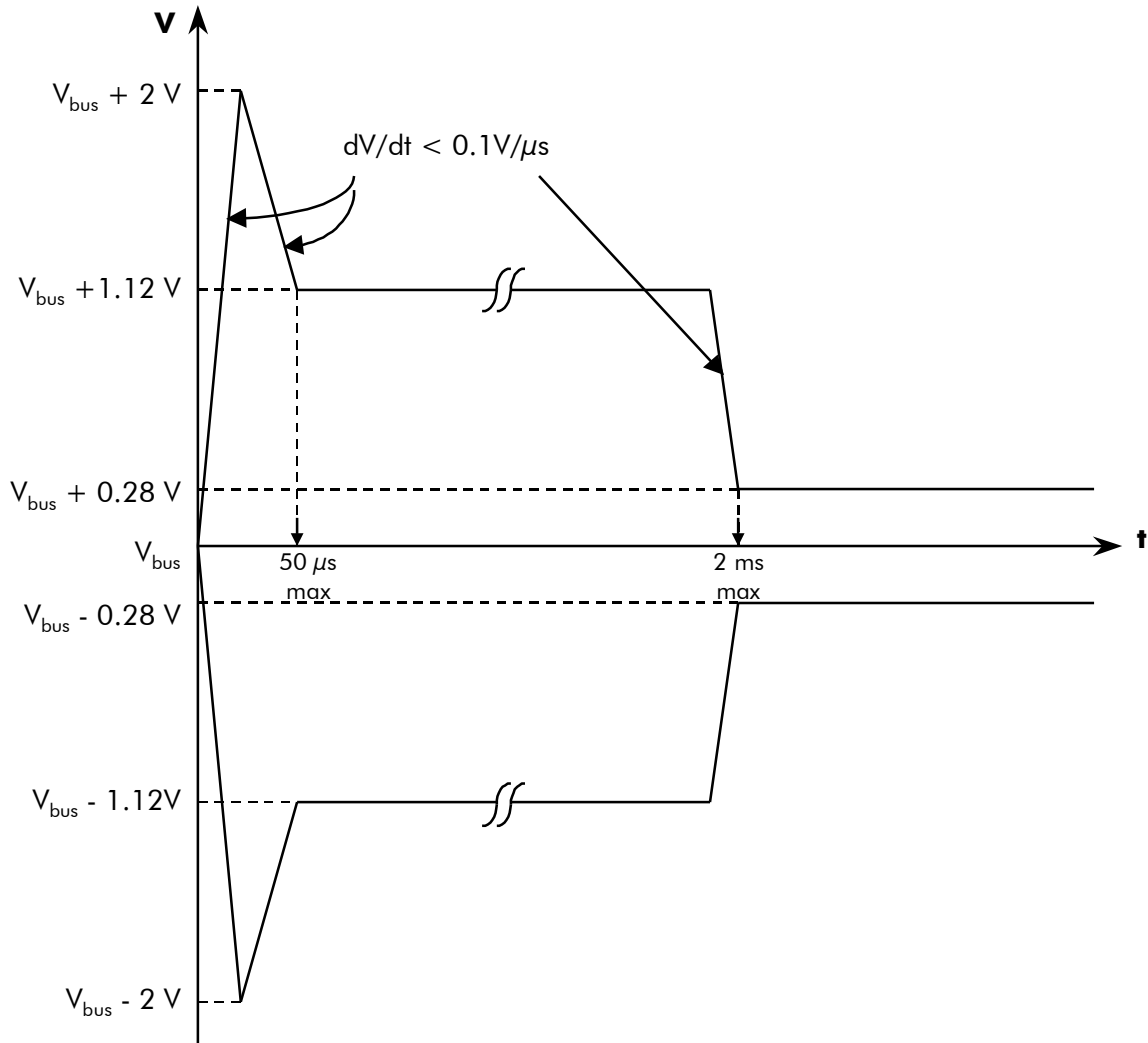

Figure 3.2.4.8.1.2-1: Voltage transient

3.2.4.8.1.3 Transient single event (common mode)

Requirement EMCPCDU-070

When short circuiting one PCDU power output through a 1 m long twisted pair, as described on the following figure, the voltage transient between return and chassis measured at another PCDU output at the end of a 6 m (TBC) cable connected to ground plane via 10 nF (TBC), shall not exceed 14 V, 2.5 μ s.

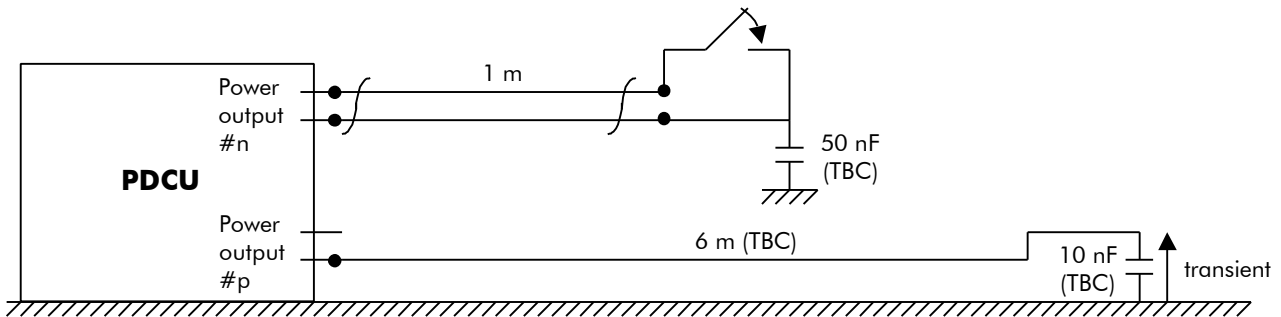

Figure 3.2.4.8.1.3-1: PCDU common mode transient test set-up

3.2.4.8.1.4 *Narrow band emissions (differential mode)*

Requirement EMCPCDU-080

In the frequency range 30 Hz – 50 MHz, the conducted emission on power lines shall not exceed the values shown in figure 3.2.4.8.1.4-1 (narrowband measurement).

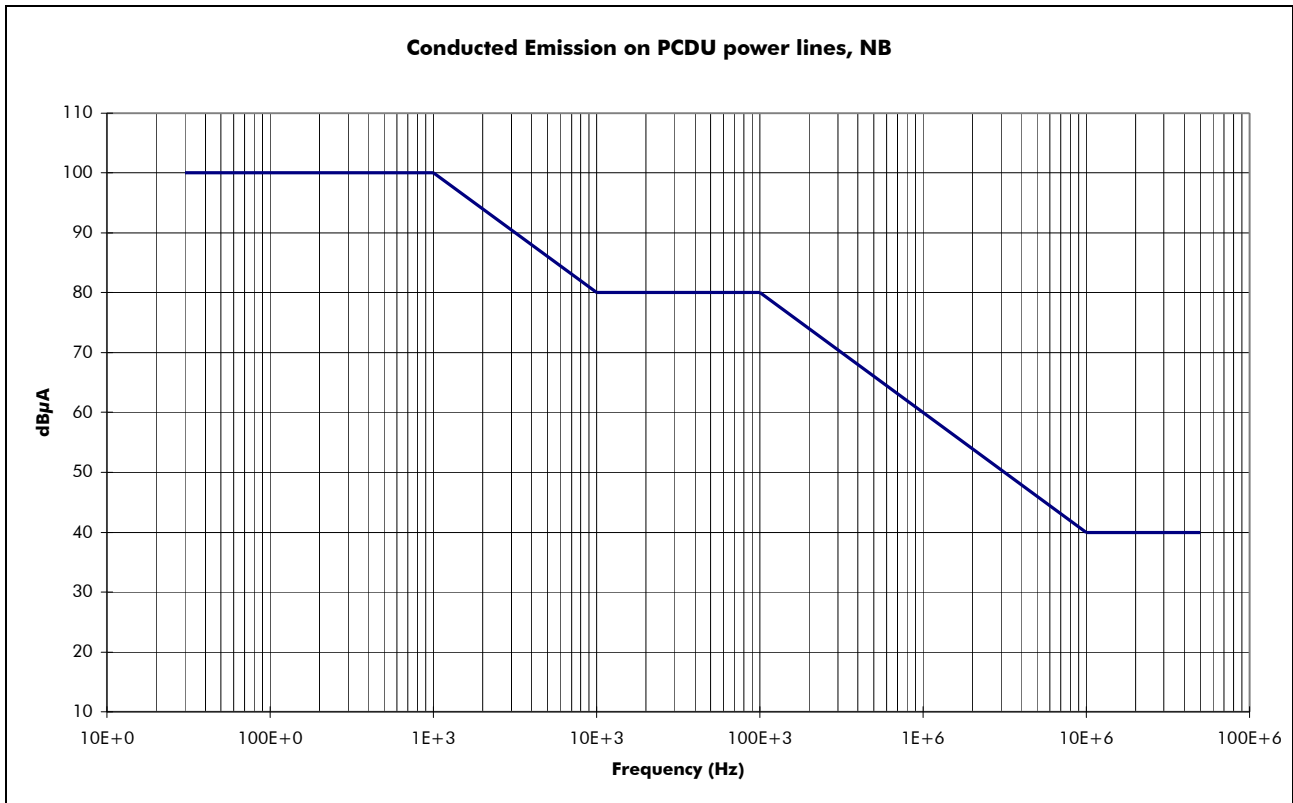

Figure 3.2.4.8.1.4-1: Conducted emission on PCDU power lines, NB

3.2.4.8.1.5 *Test conditions*

Requirement EMCPCDU-090

The above limits shall be understood as those of the PCDU connected to non inductive dummy loads leading to the following average DC currents : TBD A.

3.2.4.8.2 Conducted emission of users of PCDU power lines

3.2.4.8.2.1 Broadband emission (differential mode)

Requirement EMCEQ-400

The peak to peak value (including ripple and spikes) of the current on the hot wire of the user primary power input shall be measured with an oscilloscope, capable to detect peak to peak value, with an adequate bandwidth (≥ 50 MHz) and shall be less than 60 mA_{pp} for nominal DC input current less than 1A, to be relaxed by $\sqrt{I(A)}$ for nominal DC input current $I(A) > 1A$.

Requirement EMCEQ-410

The peak to peak value (including ripple and spikes) of the differential voltage at user input shall be measured with an oscilloscope, capable to detect peak to peak value, with an adequate bandwidth (≥ 50 MHz) and recorded for information.

3.2.4.8.2.2 Narrow band emissions

Requirement EMCEQ-420

The conducted emission shall not exceed the values shown in figure 3.2.4.8.2.2-1.

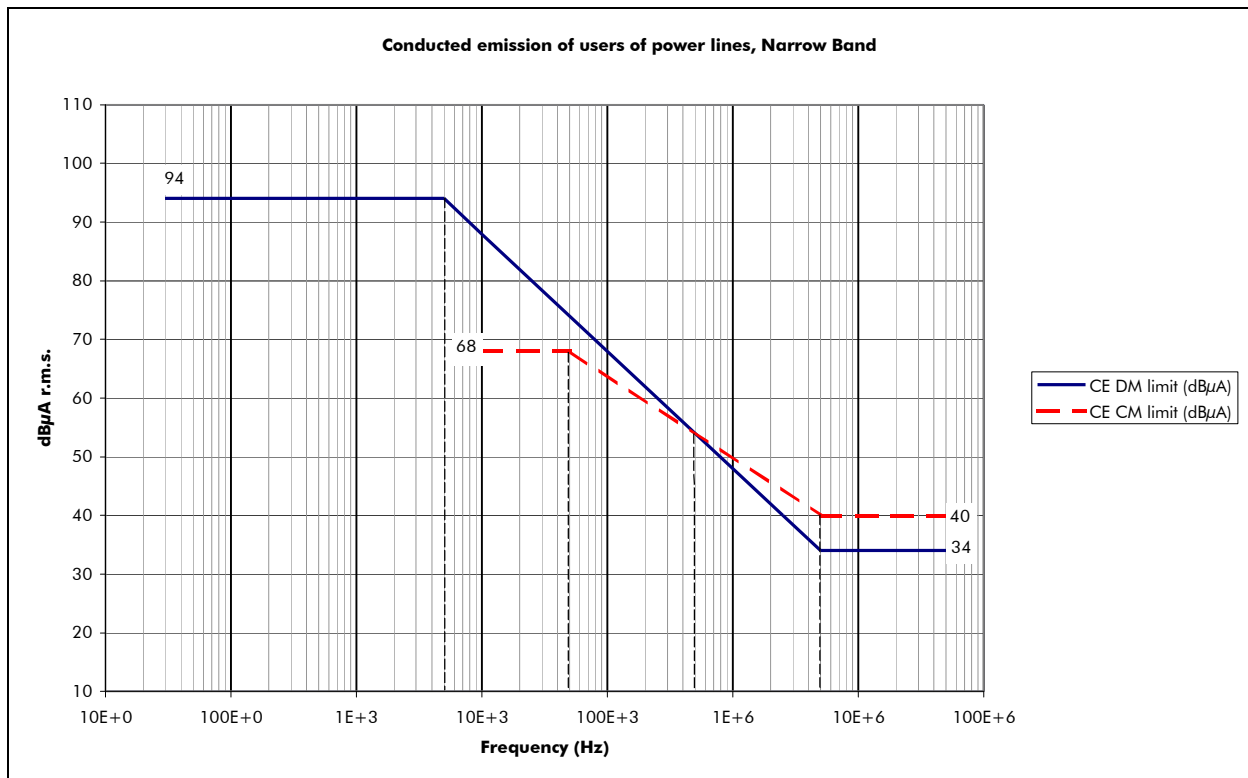

Figure 3.2.4.8.2.2-1 : CE of users of power lines

- For nominal DC input current less than 1 A, the DM curve of figure 3.2.4.8.2.2-1 is directly applicable.
- For nominal DC input current greater than 1 A, the DM curve of figure 3.2.4.8.2.2-1 shall be relaxed by $10 \cdot \log I(A)$, $I(A)$ being the nominal DC input current in Ampere.

Requirement EMCEQ-430

In order to reproduce the system power bus impedance and to standardise the measurement conditions used in different test sites, conducted emissions and susceptibility measurements on primary power lines shall be performed by inserting a Line Impedance Stabilisation Network (LISN) between the EGSE power supply and the unit under test.

Requirement EMCEQ-440

The LISN schematic and the relevant impedance versus frequency are given in figures 3.2.4.8.2.2-2 and 3.2.4.8.2.2-3.

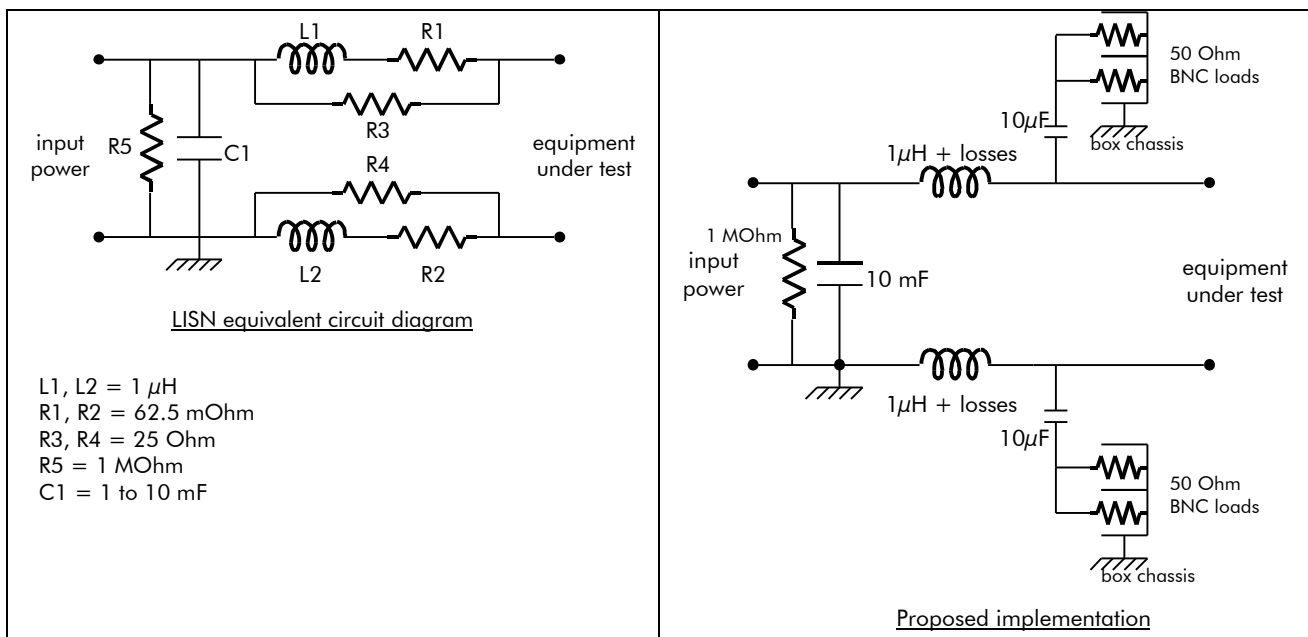

Figure 3.2.4.8.2.2-2: LISN equivalent circuit diagram and proposed implementation

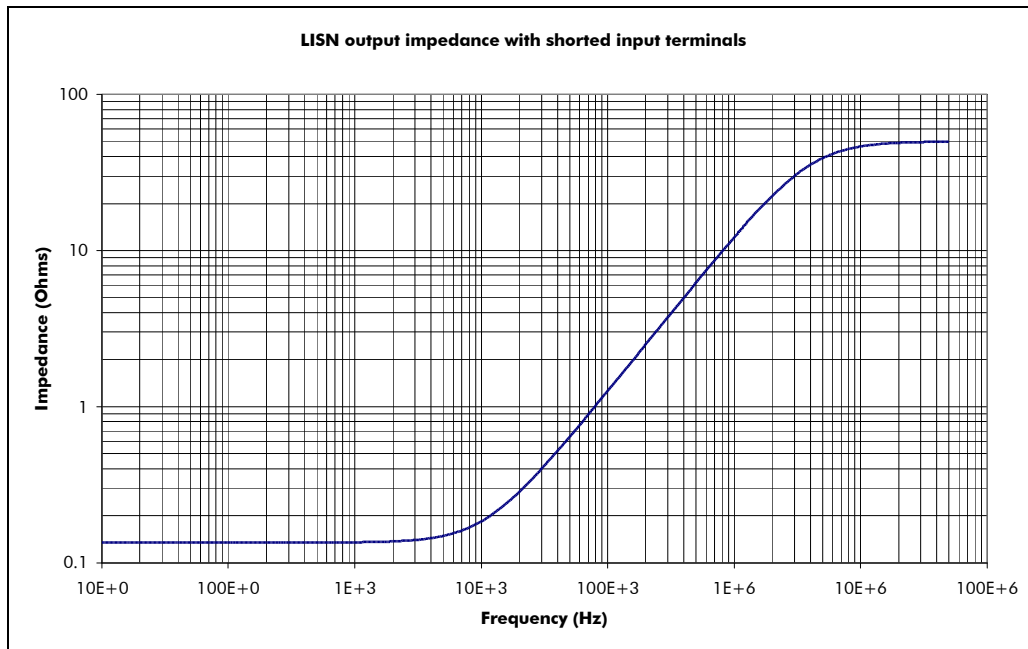

Figure 3.2.4.8.2.2-3 : LISN output impedance (input in short circuit)

Requirement EMCEQ-450

The harness length between the equipment and the LISN shall be 1 meter.

Requirement EMCEQ-460

The current measurements shall be performed separately in both differential and common modes, as defined below.

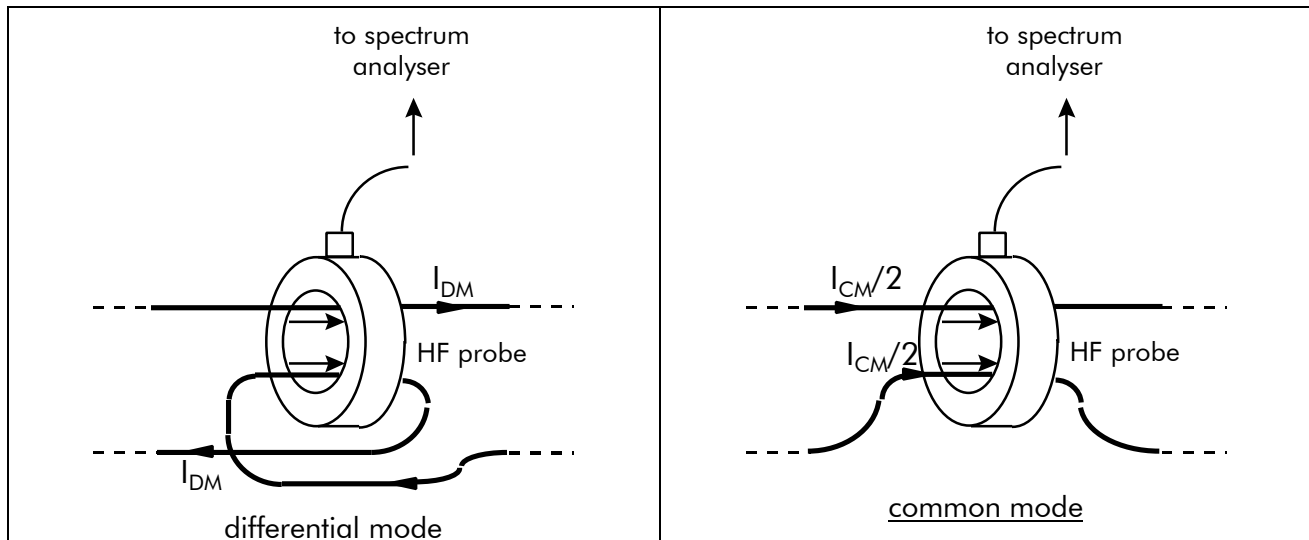

Figure 3.2.4.8.2.2-4 : differential and common mode measurements

3.2.4.8.2.3 Inrush current

Requirement EMCEQ-470

The inrush current shall be measured on the positive power line of the user connected to its 28V power supply through the LISN defined in figure 3.2.4.8.2.2-2, when switching it ON with an external bounce-free relay (e.g. laboratory mercury relay) installed between the LISN and the user on the positive power line.

Requirement EMCEQ-475

The recorded inrush current (measured with an oscilloscope in single shot mode) shall show the following 2 distinct aspects :

- A plug-in current transient corresponding to the charge of the primary filter capacitors
- A DC/DC converter start current transient

Requirement EMCEQ-480

The plug-in current transient shall be compliant with the following requirements :

- $S(I \cdot dt) < 2 \text{ mC}$
- $di/dt < 2 \text{ A}/\mu\text{s}$ (TBC)
- $I_{\text{peak}} < 30 \text{ A}$ (TBC)

Requirement EMCEQ-485

The DC/DC converter start current transient :

- shall not exceed the user line LCL current limitation value for a total time higher than (trip-off time / 2)

- shall comply with : $S(I \cdot dt) < (\text{LCL current limitation value}) \cdot (\text{trip-off time} / 2)$

Requirement EMCEQ-490

If an LCL is available at the time of inrush current testing, the test shall be repeated with the LCL inserted, and shall comply with the following mask :

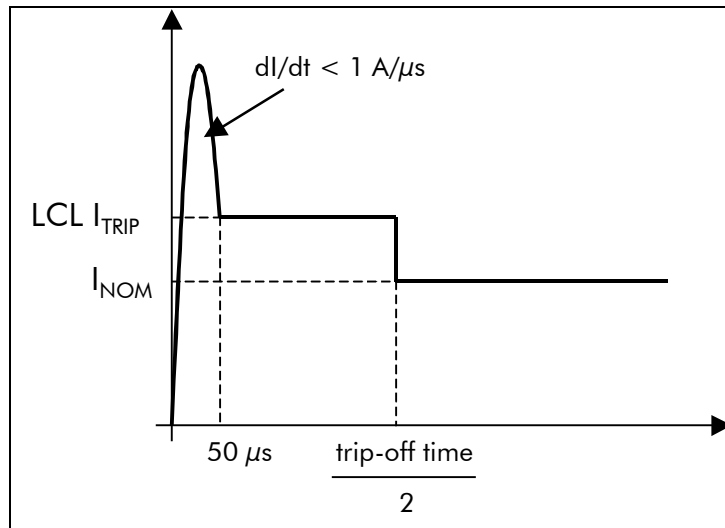

Figure 3.2.4.8.2.3-1 : inrush current template

A trip-off time / 2 = 5 ms (TBC) shall be assumed.

3.2.4.8.3 Conducted susceptibility of PCDU output power lines

Requirement EMCPCDU-100

The PCDU subsystem shall not exhibit any malfunction, degradation of performance, or deviation from specified susceptibility criteria given by the corresponding subsystem specification and test procedure when subjected to a parasitic signal on the output power lines whose characteristics are given in figure 3.2.4.8.3-1.

Requirement EMCPCDU-110

The susceptibility test shall be performed with the PCDU outputs **connected to loads defined and agreed (by Prime)**, resulting in an average DC current.

Requirement EMCPCDU-120

The sweep speed shall be less than 1 octave/minute.

Requirement EMCPCDU-130

- For PCDU CS testing above ~ 1 kHz, the level specified in figure 3.2.4.8.3-1 shall be applied considering the simultaneous injection of the perturbation on as many distribution lines as necessary to get the requested level without over-stressing the individual lines, the plateau level being "10% of total nominal current provided by PCDU" (cf. figure 6.1.3.5-1) ;
-

Requirement EMCPCDU-140

- For PCDU testing under ~ 1 kHz, different set-ups and different CS levels **shall be used** (114 dB μ Arms for a 5 A line, 120 dB μ Arms for a 10 A line, a.s.o.).
No specific CS level for 4KCDE lines is any longer foreseen because of the implementation of a preregulator at 4K cooler level (TBC).
-

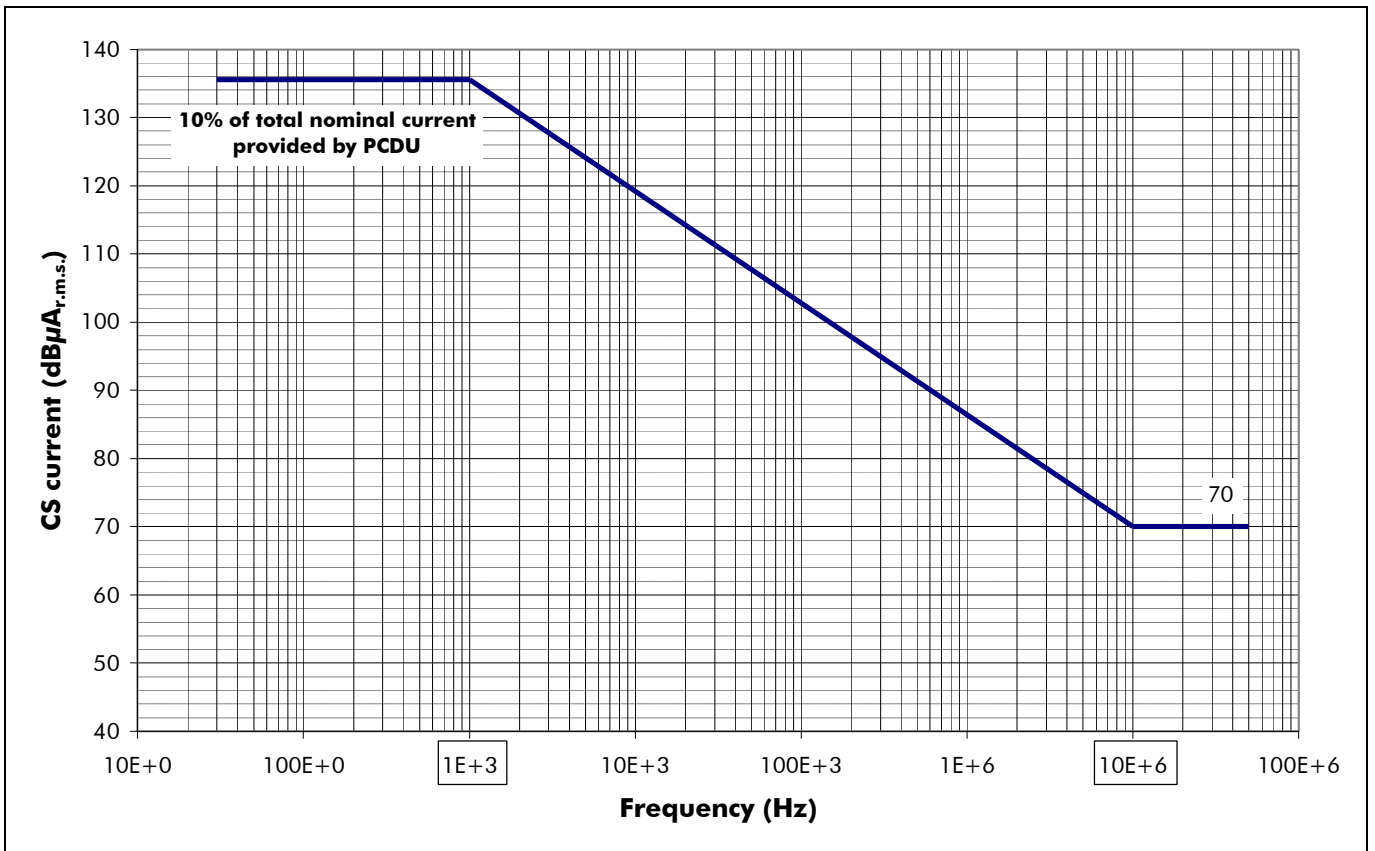

Figure 3.2.4.8.3-1: CS of PCDU power lines

3.2.4.8.4 Conducted susceptibility of users of PCDU power lines

3.2.4.8.4.1 CS continuous

3.2.4.8.4.1.1 CS continuous Differential mode

Requirement EMCEQ-500

The unit or subsystem under test shall keep nominal performance as specified in the relevant equipment/subsystem specification when subjected to the following perturbations on their input power lines :

Continuous sine wave : 1 Vrms from 30 Hz to 150 kHz, decreasing 6dB/octave up to 300 kHz and 0.5 Vrms from 300 kHz to 50 MHz (30% AM modulated by 1 kHz square wave between 50 kHz and 50 MHz)

Requirement EMCEQ-510

For continuous sine wave signals, the injected current shall be monitored and the requirement shall be considered to have been met when :

- Frequency range 30 Hz – 50 kHz : the specified test voltage level cannot be generated but the injected current has reached 1 A r.m.s. and the equipment/subsystem is still operating without malfunction and without degraded performance within its specified tolerances
 - Frequency range 50 kHz – 50 MHz : a power source of 1 W, 50 Ω impedance cannot develop the required voltage at the equipment power input terminals and the subsystem equipment is still operating without malfunction and without degraded performance within its specified tolerances
-

3.2.4.8.4.1.2 CS continuous Common mode

Requirement EMCEQ-520

The unit or subsystem under test shall keep nominal performance as specified in the relevant equipment/subsystem specification when subjected to the following perturbations on their input power lines :

Continuous sine wave : 2 Vpp from 10 kHz to 50 MHz
(30% AM modulated by 1 kHz square wave between 50 kHz and 50 MHz)

Requirement EMCEQ-530

This voltage is to be obtained between power return and chassis (cf. test set-up figure 6.1.3.1-4).

Requirement EMCEQ-535

The injected current shall be monitored and limited to one Ampere peak.

3.2.4.8.4.1.3 *Injection frequencies*

Requirement EMCEQ-540

For Differential and Common mode tests, if the CS is performed by sweeping the injection frequency, the sweep speed of the sine wave tests shall be less than 1 octave/minute.

Requirement EMCEQ-545

It will also be possible to inject discrete frequencies instead. A frequency table shall then be agreed prior to EMC TRR with the Prime.

3.2.4.8.4.2 *CS transient*

3.2.4.8.4.2.1 *CS transient Differential mode*

Requirement EMCEQ-550

The unit or subsystem under test shall undergo no change of status when subjected to the following perturbations, on its input power lines :

- Shape as per figure 3.2.4.8.4.2-2 : $E = 2.5 \text{ V}$, rise time $10 \mu\text{s}$, flat portion of the pulse $\sim 300 \mu\text{s}$, time constant = 2 ms
-

Requirement EMCEQ-560

Both polarities shall be tested :

- A positive pulse at the highest allowed supply voltage (29V TBC)
 - A negative pulse at the lowest voltage limit (26V TBC)
-

Requirement EMCEQ-565

The repetition rate shall range from 5 Hz to 10 Hz.

3.2.4.8.4.2.2 CS transient Common mode

Requirement EMCEQ-570

The unit or subsystem under test shall undergo no change of status when subjected to the following perturbations, on its input power lines :

- Shape as per figure 3.2.4.8.4.2-1 :
 - Amplitude $E = 28 \text{ V}$ (during injection)
 - Rise time : $\leq 100 \text{ ns}$ (t_r)
 - Duration : $\geq 5 \mu\text{s}$ (τ).
-

Requirement EMCEQ-580

Both polarities shall be tested.

Requirement EMCEQ-585

The repetition rate shall range from 5 Hz to 10 Hz.

Requirement EMCEQ-587

The transient spurious signal shall be injected between the power return wire and the unit case.

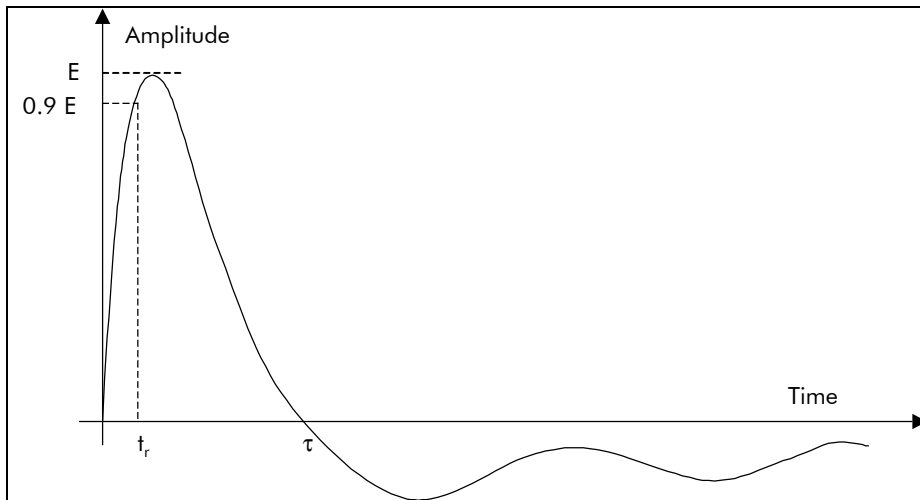

Figure 3.2.4.8.4.2-1 : CS06 transient typical shape

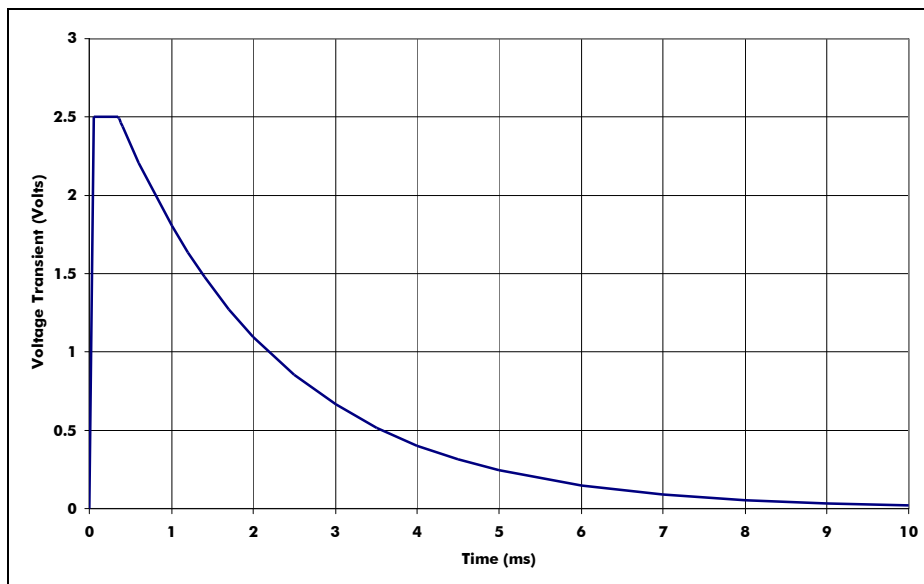

Figure 3.2.4.8.4.2-2 : step load transient shape

3.2.4.9 Conduction requirements on TM/TC lines (TBC)

3.2.4.9.1 General requirements

Requirement EMCEQ-600

The tests are applicable at each TM/TC input/output. In case of identical input/output circuits, 2 circuits or 10% (whichever is more) of each type shall be tested.

3.2.4.9.2 Conducted Emission requirements on signal lines

Requirement EMCEQ-610

For the CE tests, the lines shall be loaded at both ends : one end by the tested unit, the other end by the EGSE (if applicable) or by a dummy load as specified in GDIR (§ 6.8). The dummy load shall include differential and common mode impedance, as far as possible representative of the actual interface.

By default, the following load shall be used :

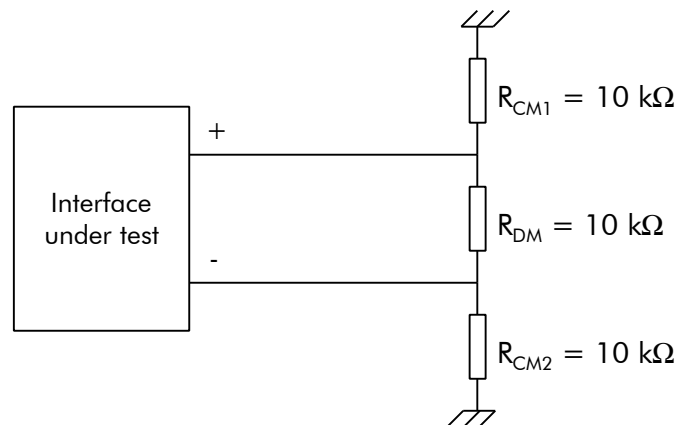

Requirement EMCEQ-620

The CE tests to perform shall be the following :

Interface under test	Output (emitter)	Input (receiver)
HP, HL & EHL commands	CM	CM
SBDL	DM + CM	DM + CM
ANA TM	DM + CM	DM + CM
TH TM	/	DM + CM
DR TM, DB TM	DM + CM	DM + CM

Requirement EMCEQ-630

The corresponding CE limits shall be the following (measured in time domain with a 50 MHz minimum bandwidth oscilloscope) :

Interface under test	DM	CM
HP, HL & EHL commands	/	1 V _{pp} (ripple + spikes)
SBDL	100 mV _{pp}	1 V _{pp} (ripple + spikes)
ANA TM	Ripple : 20 mV _{pp} Spikes : 300 mV _{pp}	1 V _{pp} (ripple + spikes)
TH TM	Ripple : 20 mV _{pp} Spikes : 300 mV _{pp}	1 V _{pp} (ripple + spikes)
DR TM, DB TM	Ripple : 100 mV _{pp} Spikes : 300 mV _{pp}	1 V _{pp} (ripple + spikes)

The spikes shall be defined as transitory high frequency oscillations with duration < 1 μs and pseudo frequency > 5 MHz

3.2.4.9.3 Conducted Susceptibility requirements on signal lines

Requirement EMCEQ-640

The CS tests to perform shall be the following :

Interface under test	Output (emitter)	Input (receiver)
SBDL	/	DM+CM
ANA TM	/	CM
TH TM	/	CM
DR TM, DB TM	/	CM

Requirement EMCEQ-650

The corresponding CS test levels shall be the following :

Interface under test	DM	CM
SBDL	200 mV _{pp} [1 kHz – 50 MHz]	2 V _{pp} [50 kHz – 50 MHz]
ANA TM	/	2 V _{pp} [50 kHz – 50 MHz]
TH TM	/	2 V _{pp} [50 kHz – 50 MHz]
DR TM, DB TM	/	2 V _{pp} [50 kHz – 50 MHz]

Requirement EMCEQ-660

The source impedance for CS shall be 50 Ω for current limitation purpose.

Requirement EMCEQ-670

The generic test set-up is described of the following figure :

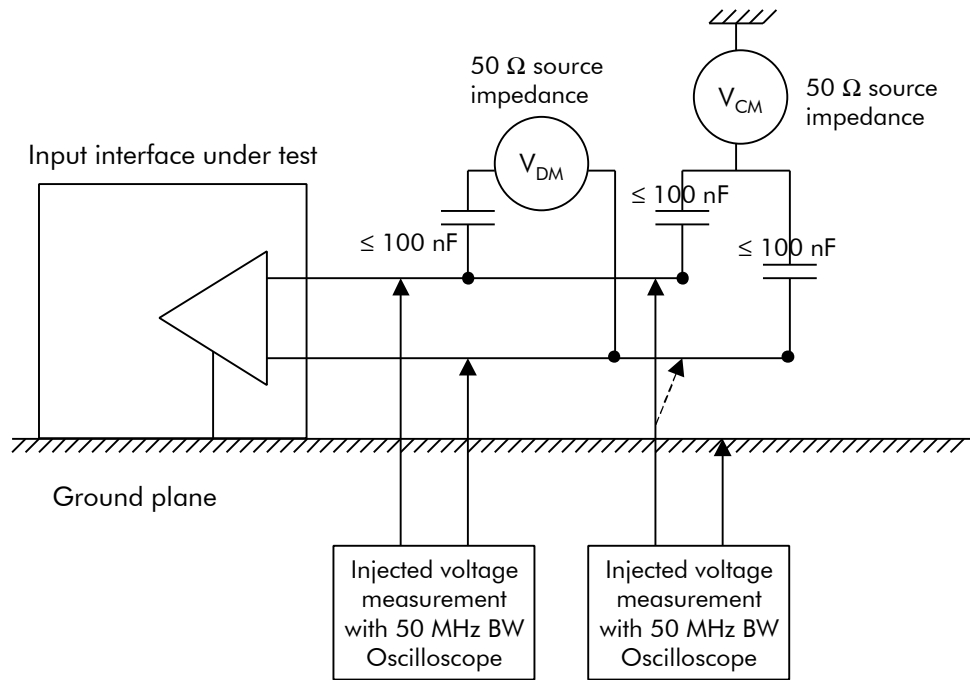

Alternative injection with a current probe is allowed.

Requirement EMCEQ-680

For common mode injection, the specified level has to be set either on hot or return whichever reaches the specified level first.

3.2.4.9.4 EMC requirements on 1553 bus

Requirement EMCEQ-690

The 1553 terminals EMC characteristics shall be compliant with the MIL-STD-1553B standard.

Extracts are reproduced hereafter for information :

Conducted emission :

- (§ 4.5.2.1.1.2) output waveform : “[...] any distortion of the waveform including overshoot and ringing shall not exceed $\pm 900 \text{ mV}_p$, line-to-line”.
- (§ 4.5.2.1.1.3) output noise : “any noise transmitted when the terminal is receiving or has power removed shall not exceed a value of $14 \text{ mV}_{\text{RMS}}$, line to line”.
- (Notice 2, § 30.10.6) power on/off noise : “a terminal shall limit any spurious output during a power-up or power-down sequence. The maximum allowable output noise amplitude shall be $\pm 250 \text{ mV}_p$, line to line for transformer coupled stubs”.

Conducted susceptibility :

- (§ 4.5.2.1.2.2) common mode rejections : “any signals from direct current (DC) to 2 MHz, with amplitude equal to or less than $\pm 10 \text{ V}_p$, line-to-ground, shall not degrade the performance of the receiver”.
- (§ 4.5.2.1.2.4) noise rejection : “the terminal shall exhibit a maximum word error rate of one part in 10^7 , on the words received by the terminal [...] when operating in the presence of additive white gaussian noise distributed over the bandwidth of 1 kHz to 4 MHz at an RMS amplitude of 140 mV ”.

4. SPACECRAFT TESTING CONDITIONS REQUIREMENTS

4.1 TESTING FACILITIES

Requirement EMCSYS-100

The spacecraft shall be placed in a clean room (anechoïc clean room mandatory for radiated testing) where the ambient noise is at least 6 dB below the test level in all the required frequency ranges.

4.2 SPACECRAFT OPERATIONAL CONFIGURATION

For tested operational configurations, refer to EMC test plan as included in the EMC control plan.

4.3 RADIATED EMISSION

Requirement EMCSYS-110

Narrowband, E-field emission shall be determined at 1 meter distance from the S/C for assessment of ambient field around cryostat, while determined in the VEB plane for L.V. compatibility testing.

4.4 SUSCEPTIBILITY TESTING

Requirement EMCSYS-120

It is assumed that all monitoring of HERSCHEL and PLANCK, particularly concerning experiments aspects is performed via telemetry and practically near real time monitoring is required. If monitoring time becomes substantial (to be compared to sweep speed of about 1 octave/minute), only agreed discrete frequencies will be tested.

5. MODULE TESTING CONDITIONS REQUIREMENTS

5.1 PAYLOAD MODULE CONDITIONS

The requirements stated in chapter 4 (spacecraft testing conditions requirements) are fully applicable to payload module, with the exception of launch vehicle requirements verification.

Requirement EMCPLM-100

For conducted tests on primary power lines, the PCDU impedance shall be simulated by the LISN defined § 3.2.4.8.2.2.

5.2 SERVICE MODULE CONDITIONS

Refer to HERSCHEL/PLANCK spacecraft testing.

6. EQUIPMENT/SUBSYSTEM TESTING CONDITIONS

6.1 TEST SET-UP REQUIREMENTS

Requirement EMCEQ-700

Test set-ups deviating from the ones described in this document shall be subject to the Prime approval.

6.1.1 General test set-up requirements

Requirement EMCEQ-705

The test shall be performed in an ambient electromagnetic environment which is at least 6 dB below the performance levels required in section 3.2.4. Included in the ambient level are also emissions from test equipment, including unit-testers (EGSE) with its harness.

Requirement EMCEQ-710

Measuring antenna ends shall not be closer than 1.0 meter from any electrically conductive elements during the test.

Requirement EMCEQ-715

No shielding between the test set-up and measurement antennas is allowed.

Requirement EMCEQ-720

The test harness length shall be as a minimum 3 meters of which 2 meters shall be exposed 5 cm from the edge of the ground plane at a 5 cm height. Breakout boxes which are used for the line measurements shall be carefully designed to fulfil the purpose of the test.

Requirement EMCEQ-730

Grounding of interfaces shall be in accordance with flight installation.

Requirement EMCEQ-740

Bonding of units – unit tester, etc... to the ground plane shall be verified by bonding test.

Requirement EMCEQ-745

The unit bond shall be similar to that specified for the actual installation.

Requirement EMCEQ-750

The tests shall be performed with the samples, unit-testers (EGSE) and harness placed on a conductive ground plane with a length greater than 2,5 meters and width of more than 1 meter.

Requirement EMCEQ-755

If shielded room is used the groundplane shall be bonded to the room with low inductive bonds separated by less than 0,5 meter. This connection shall be verified by a resistance test.

Requirement EMCEQ-760

In the case where real electrical/electronic loads cannot be used these shall be simulated by dummy loads with similar characteristics.

Requirement EMCEQ-765

It is forbidden to take the interface wires to ground if not done in the actual installation.

Requirement EMCEQ-770

The test harness must be similar to flight condition : this applies also to the type of cables. Shielded wires shall not be used in the test set-ups unless they have been agreed by the Prime Contractor. The cable configuration, except the length, shall thus be in agreement with approved interface drawings.

Requirement EMCEQ-775

No overall cable shields are allowed unless used in the actual design.

Requirement EMCEQ-780

Radiated susceptibility tests shall be performed in such a way that regulations and laws at the test location are met.

Requirement EMCEQ-785

Reflection effects shall be minimised by means of absorber materials.

Requirement EMCEQ-790

All equipment used for emission and susceptibility tests shall be calibrated and wear calibration certificate.

Requirement EMCEQ-795

Passive equipment, such an antennae, current probes, etc... must have calibration curves.

6.1.2 Test set-up for emission measurement

6.1.2.1 CEP conducted emission, power lines (for PCDU loads)

The suggested test set-up is as shown in figure 6.1.2.1-1.

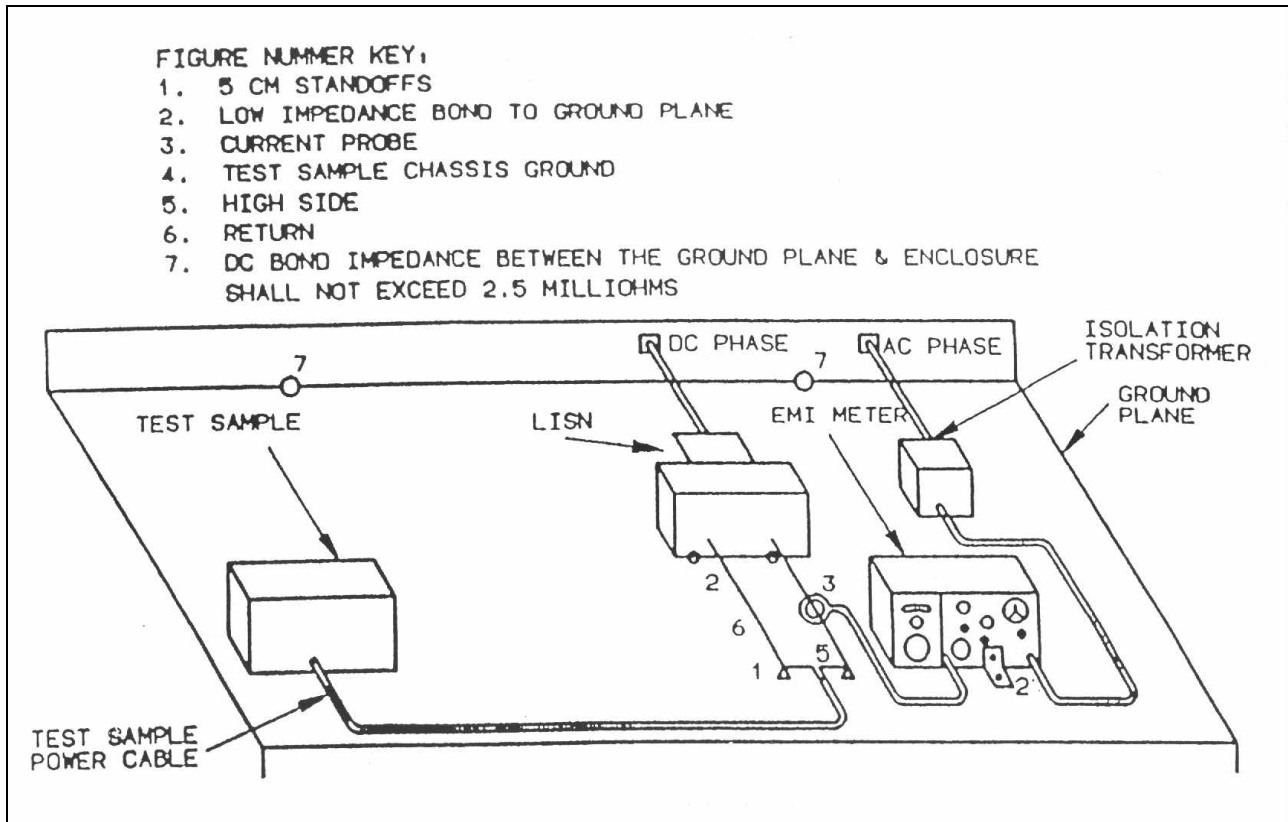

Figure 6.1.2.1-1: Conducted emission, test set-up (for power supply loads)

Requirement EMCEQ-800

Any switch for ON/OFF test will be positioned between the LISN and the unit under test. The transients are then measured on the power lines between the switch and the unit under test.

6.1.2.2 RE-E radiated emission, E-field

The suggested test set-up is as shown in figure 6.1.2.2-1.

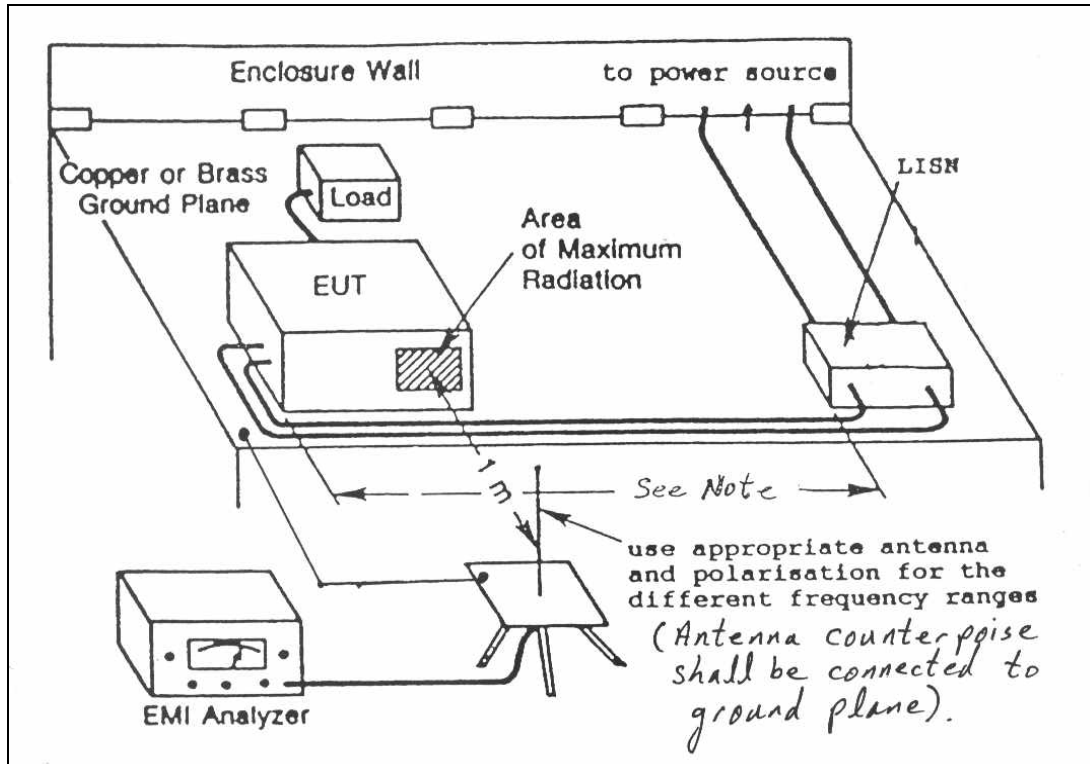

Figure 6.1.2.2-1: Radiated emission, E-field test set-up

Requirement EMCEQ-810

The emission at the antenna at one meter distance from the test object which gives the highest reading shall be the RE-E level.

Requirement EMCEQ-815

Power lines cable lengths shall be 1m maximum ; in the case of signal/control lines, the interconnecting cable length exposed to the field shall be representative of the spacecraft or 2 m (whichever is less).

6.1.2.3 RE-H radiated emission, H-field (AC)

The suggested test set-up is as shown in figure 6.1.2.3-1.

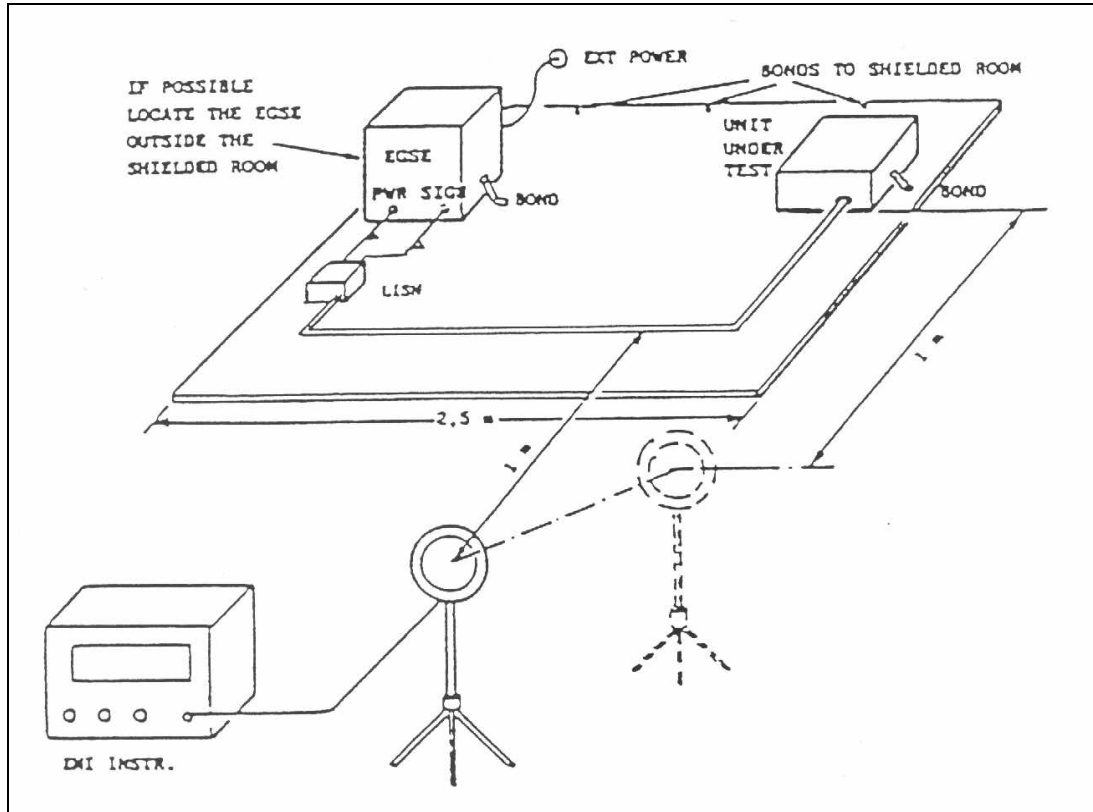

Figure 6.1.2.3-1: Radiated emission, H-field test set-up

Requirement EMCEQ-820

The emission at the antenna at one meter distance from the test object which gives the highest reading shall be the RE-H level.

6.1.2.4 Hdc emission, H-field (DC)

Requirement EMCEQ-830

For DC magnetic field measurements, the following steps shall be performed :

- Each orthogonal unit axis shall be depermed by a field, between 5Hz and 60Hz, creasing up to 4 milliteslas in 200 sec. minimum then decreasing from 4 milliteslas to zero in 400 sec. minimum.
- Measure maximum field (*) at 1 meter from the geometric centre of unit/subsystem (or less if the validity of the cubic law is proved) and record dipole direction and level.
- Each unit axis shall be permed by 0.5 millitesla during 60 sec.
- Measure maximum field (*) at 1 meter from the geometric centre of unit/subsystem (or less if the validity of the cubic law is proved) and record dipole direction and level.
- Each orthogonal unit axis shall be depermed as defined at first step.

(*) The minimum measurements to be performed are $\pm X$, $\pm Y$ and $\pm Z$ axes of the unit/subsystem.

6.1.3 Test set-up for susceptibility tests

6.1.3.1 CSP conducted susceptibility, power lines

The test set-ups are shown in the figures next pages :

- Differential mode, continuous signals : 6.1.3.1-1 and 6.1.3.1-2
- Differential mode, transients : 6.1.3.1-3
- Common mode; continuous signals : 6.1.3.1-4
- Common mode, transients : 6.1.3.1-5

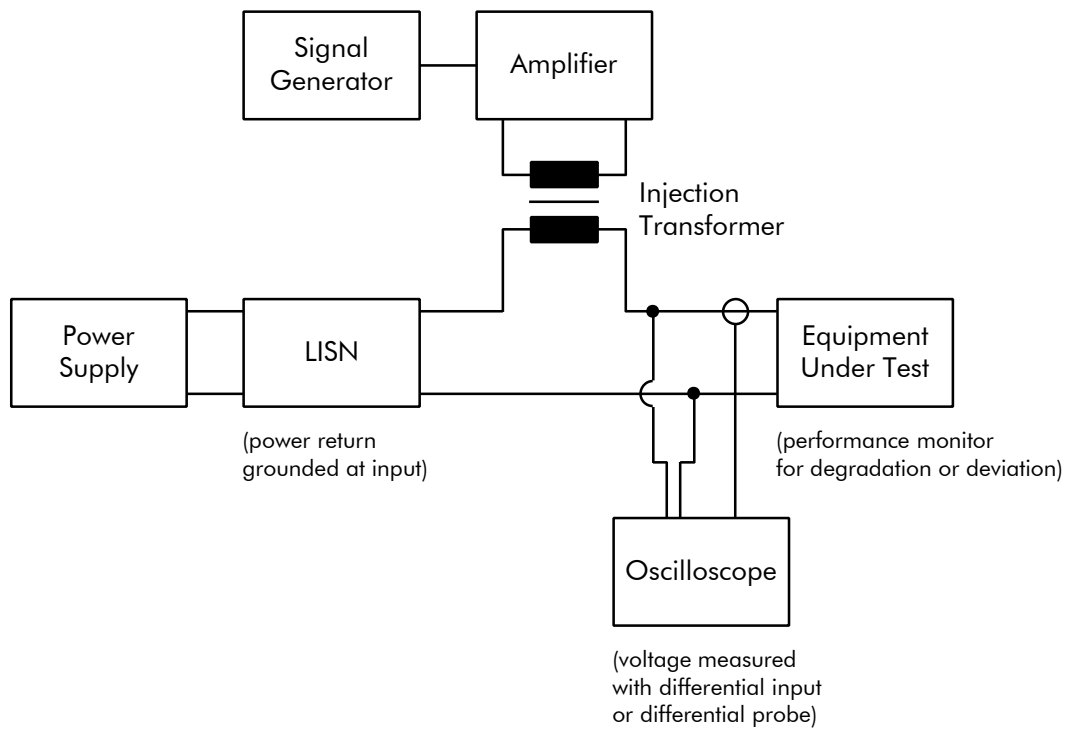

Figure 6.1.3.1-1: Conducted susceptibility (30 Hz – 50 kHz)
(for continuous signals injection)

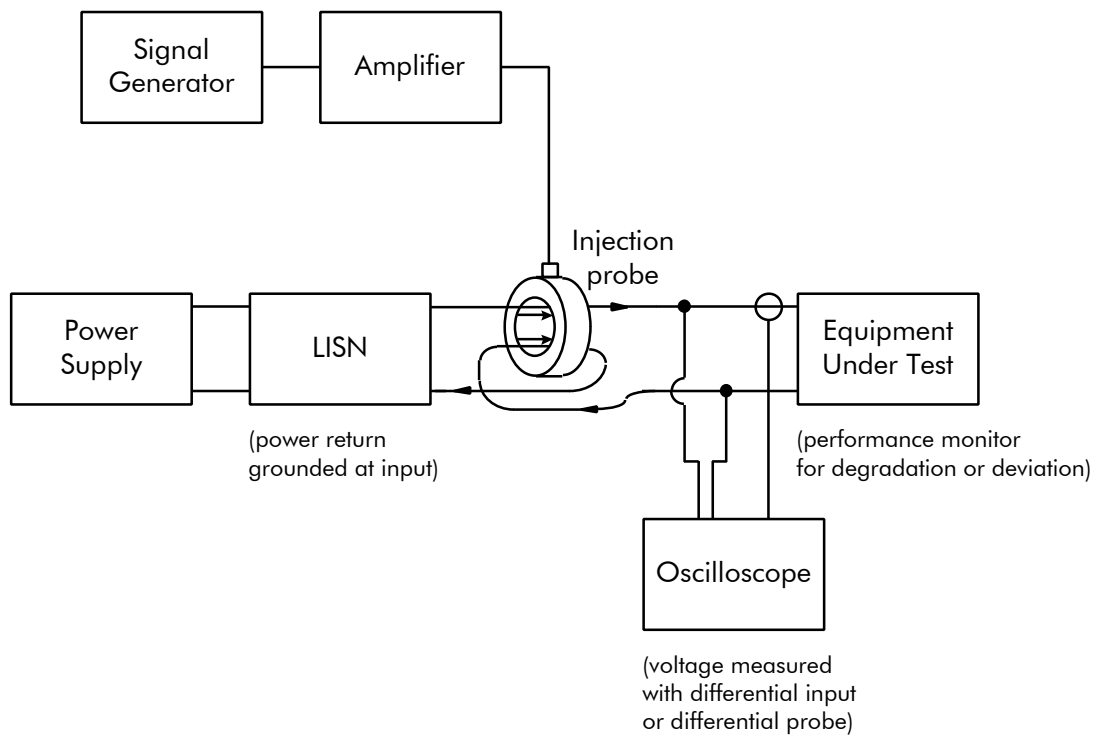

Figure 6.1.3.1-2: Conducted susceptibility (50 kHz – 50 MHz)
(for continuous signals injection)

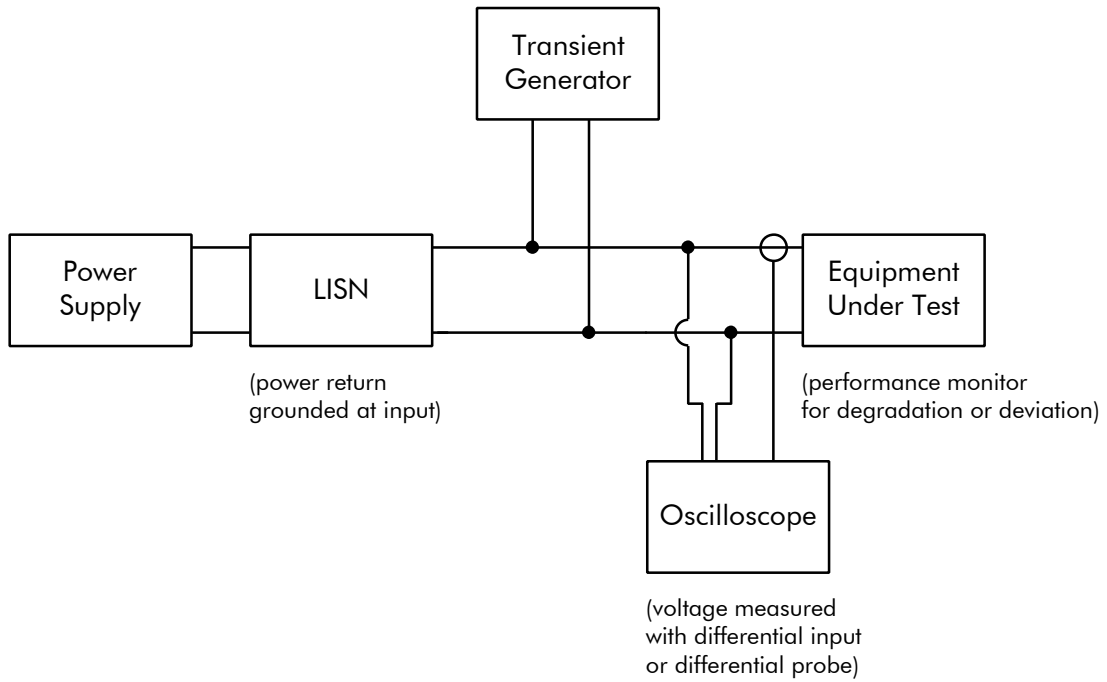

Figure 6.1.3.1-3: Conducted susceptibility, transients, differential mode (transient parallel injection)

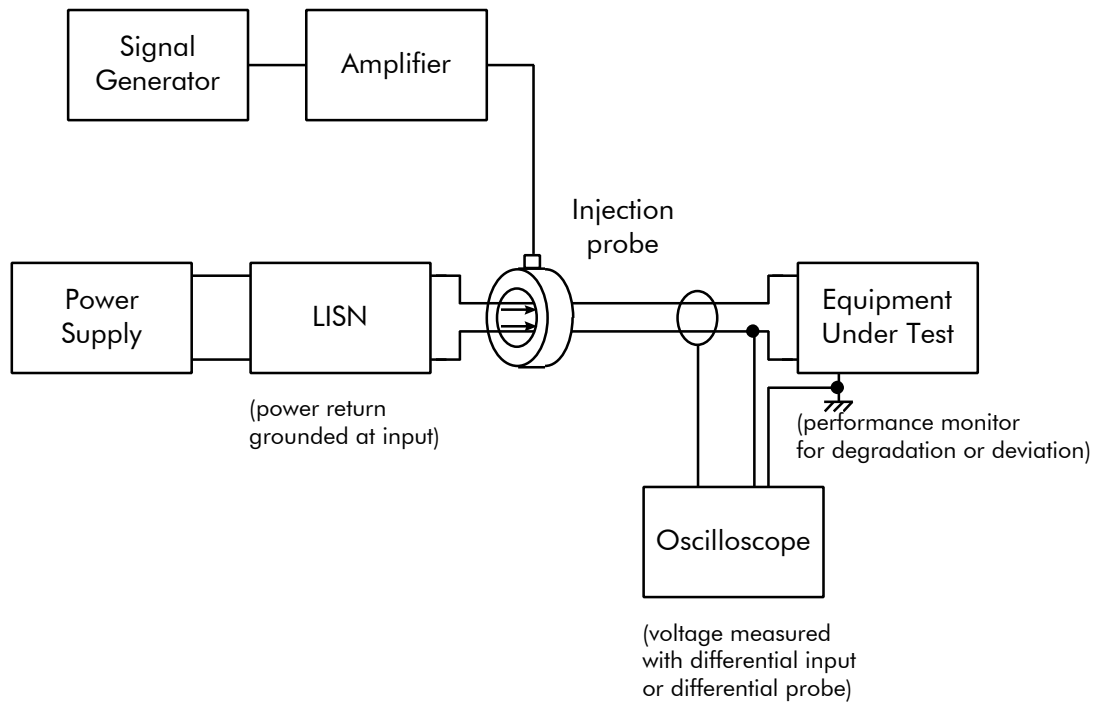

Figure 6.1.3.1-4 : Conducted susceptibility, continuous signals, common mode

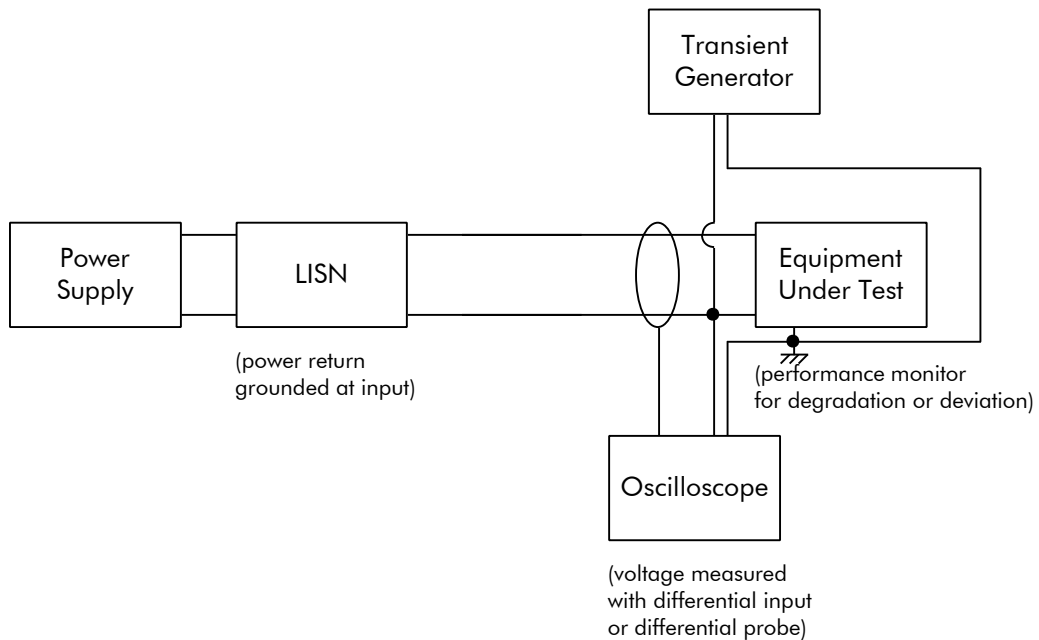

Figure 6.1.3.1-5 : Conducted susceptibility, transients, common mode (transient parallel injection)

Requirement EMCEQ-835

The injected current relevant to the susceptibility threshold or to voltage limit shall be monitored and recorded.

6.1.3.2 RS-E radiated susceptibility, E-field

Requirement EMCEQ-840

The test set-up shall be as in figure 6.1.3.2-1.

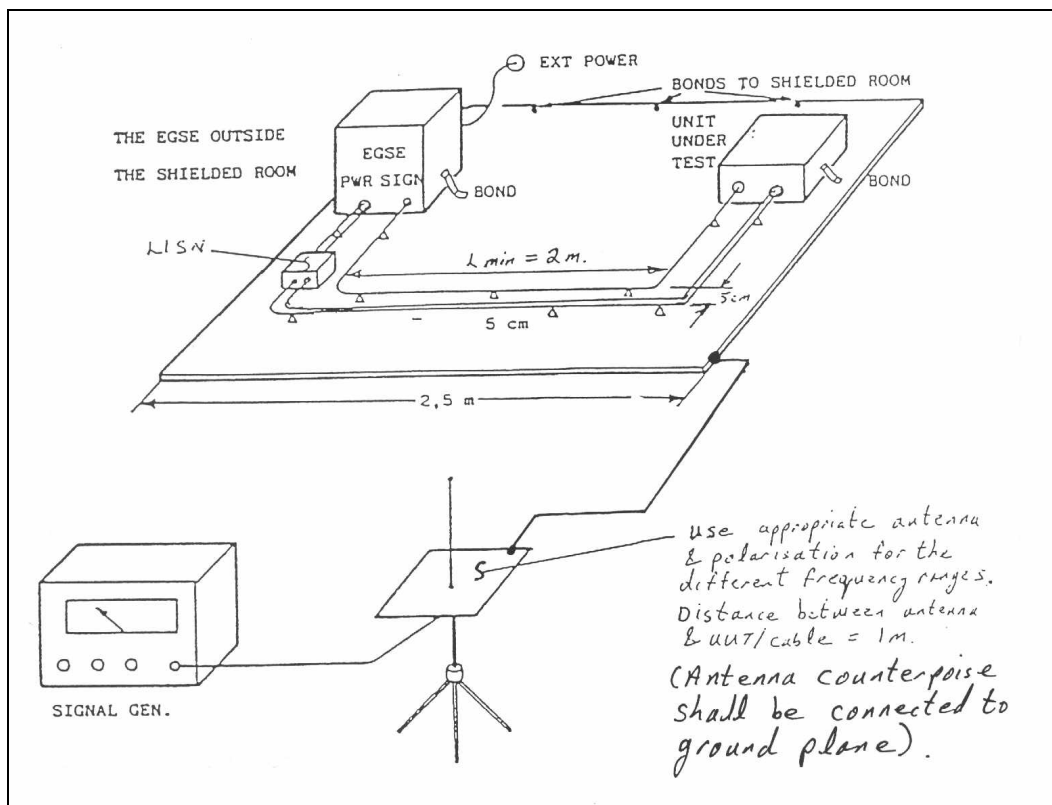

Figure 6.1.3.2-1 : Radiated susceptibility E-field test set-up

Requirement EMCEQ-845

The distance between the radiating antenna and the unit under test shall be not less than 1 meter.

Requirement EMCEQ-847

In case the specified field strength cannot be achieved, a shorter distance is permitted as long as the test region against the field strength is measured and specified.

6.1.3.3 RS-H radiated susceptibility, H-field

Requirement EMCEQ-850

The test set-up shall be as in figure 6.1.3.3-1.

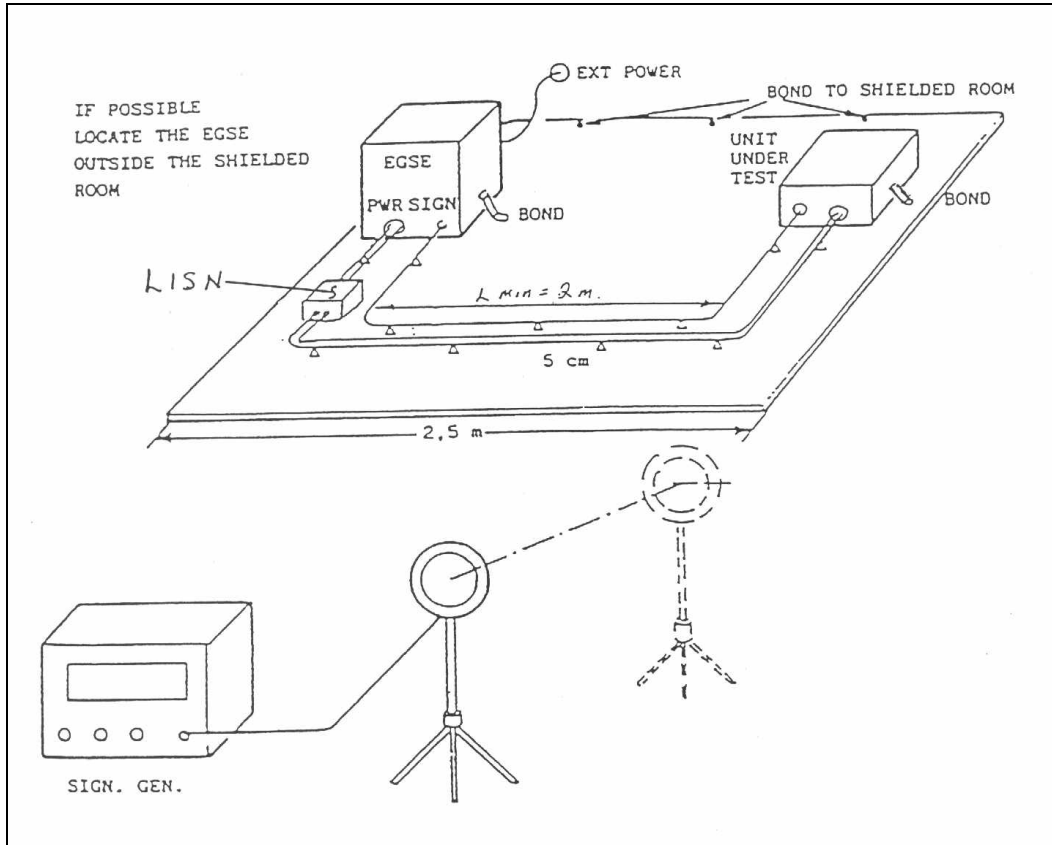

Figure 6.1.3.3-1: Radiated susceptibility H-field test set-up

Requirement EMCEQ-855

The distance between the radiating antenna and the unit under test shall be the most suitable to achieve the specified level of field strength in the test region.

Requirement EMCEQ-857

Should it be impossible to reach a uniform H Field at the unit location ("big" unit/subsystem), the test shall be done by moving the antenna around the unit under test.

6.1.3.4 ESD electrostatic discharge susceptibility

Requirement EMCEQ-860

The test set-up shall be as in figure 6.1.3.4-1.

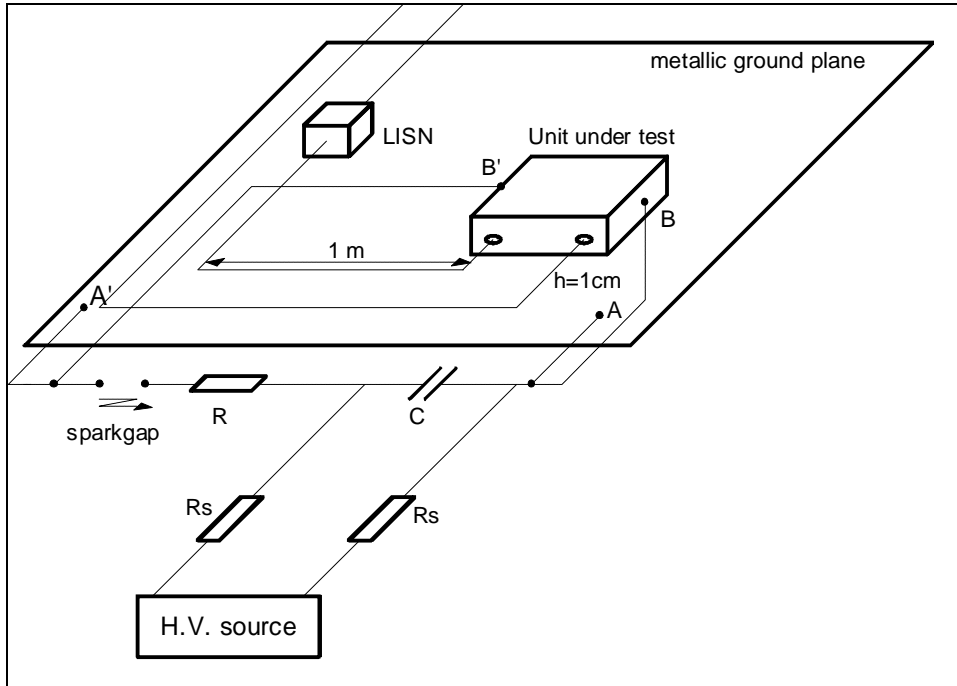

Figure 6.1.3.4-1 : Test set up of conducted discharges into unit structure and into ground plane under the harness

6.1.3.5 PCDU Conducted Susceptibility

The test set-up for PCDU CS testing above ~ 1 kHz is shown on figure 6.1.3.5-1.
 Care shall be taken not to over stress the individual power lines when using this simultaneous injection strategy.

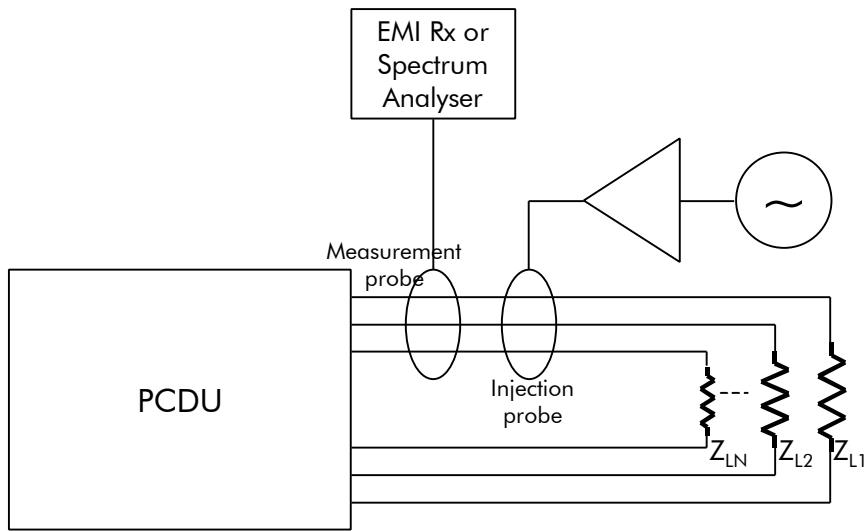

Figure 6.1.3.5-1 : Test set-up for PCDU CS

6.2 TEST GUIDELINES

6.2.1 Accessory equipment precaution

Care shall be taken to ensure that all accessory equipment used do not affect measurement integrity.

6.2.2 Excess personnel and equipment

The shielded enclosure of EMC test area shall be kept free of unnecessary equipment, cable racks and desks.

Only the equipment essential to the test being performed shall be present.

Personnel not actively involved shall not be permitted in the enclosure or test area.

6.2.3 Use of measuring equipment

All equipment used shall be within calibration and operated as prescribed in the respective instruction manuals unless otherwise specified in the appropriate test procedure and approved by the Prime Contractor.

6.2.4 Identification of spurious responses in measuring equipment

The measuring equipment shall be monitored first for spurious emissions. False data caused by such spurious emissions shall be identified on X-Y recordings.

6.3 TEST EQUIPMENT

The EMC tests have to be performed using suitable equipment. The following equipment is given for guidance only, any other commercially available equipment may be used provided that it has the necessary technical characteristics to perform the test.

6.3.1 Ground plane

Material : copper or brass

Minimum thickness : 0.25 mm for copper, 0.60 mm for brass

Minimum area : 2.25 m²

Finish : clean metal, untreated

Expanded polystyrene blocks may be used to support the bundles at the required height.

6.3.2 Tolerance of test parameters

The maximum allowable tolerance for test parameters shall be as follows unless otherwise specified within this specification or the applicable equipment specification.

The tolerance specifies the allowable range within which the specified test level may vary and is exclusive of instrument accuracy :

- Test times : 0 to 10%
- Amplitude : +/- 2 dB
- Frequency : +/- 2%

Test equipment accuracy shall be declared in the supplier generated EMC test procedure.

The accuracy of instruments and test equipment used to control or measure the test parameters shall be at least one third the tolerance for the variable to be measured. The actual measurement accuracy shall be declared in the test procedure.

All instrumentation to be used for qualification and acceptance tests shall be subjected to approved calibration procedures and shall be within the normal calibration periods at the time of test. Instrumentation which will run out of calibration period during the planned test time shall not be used.

All test equipment shall be calibrated in accordance with the requirements of MIL-C-45662A.

Calibration labels shall be used on applicable test equipment and instruments and shall include the item serial number, last date of calibration, date of expiration and the identification of the calibration technician.

6.3.3 Suggested test antennas

The following antenna are recommended for E and H-field tests. For susceptibility measurements any antenna can be used : the field strength shall be monitored in the test region in the vicinity of the unit under test. However, different antennas may be used provided calibration curves are available.

6.3.3.1 E-field antennas

6.3.3.1.1 Frequency 10 kHz – 30 MHz

For emission measurements a 104 cm rod antenna with an electric length of 50 cm and an appropriate matching network, as required, with a square counterpoise of 60 x 60 cm shall be used. The counterpoise shall be connected (by a low impedance bond) to the ground plane.

For radiated susceptibility tests with a field strength up to 1V/m the 104 cm antenna may be used with matching network.

6.3.3.1.2 Frequency 30 MHz – 200 MHz

In the frequency range 30 MHz to 200 MHz the radiated emission and susceptibility tests can be performed using a bi-conical antenna having the following specification :

- Frequency range : 30 to 200 MHz
- Impedance : matched to 50 Ohms
- Length : 144 cm
- Diameter : 54 cm
- Depth : 61 cm

Equivalent calibrated antenna can also be considered.

6.3.3.1.3 Frequency 200 MHz – 1 GHz

In the frequency range 200 MHz to 1 GHz, the radiated emission and susceptibility tests shall be performed using the following antennas :

- Log-periodic
- Conical logarithmic spiral antenna
- Double ridged Guide Antenna

6.3.3.1.4 Frequency 1 GHz – 10 GHz

In the frequency range 1 GHz to 10 GHz, the radiated emission and susceptibility tests shall be performed using either one of the following two antennas :

- Conical logarithmic spiral antenna 1 GHz – 10 GHz
- Double ridged Guide Antenna 1 GHz – 10 GHz

6.3.3.1.5 Frequency 10 GHz – 26 GHz

In the frequency range 10 to 26 GHz, the radiated emission and susceptibility tests shall be performed using standard gain horn antennas including antenna dishes if necessary.

6.3.3.2 H-field antennas

For radiated emission tests as well as radiated susceptibility tests loop antennas shall be used having following characteristics :

6.3.3.2.1 Radiated emission

The loop antenna together with the EMI receiving equipment shall be capable of measuring magnetic flux densities at least 20 dB below the applicable limits for this tests

6.3.3.2.2 Radiated susceptibility

The loop antenna together with the signal source shall be capable of supplying sufficient current to produce magnetic flux densities 10 – 20 dB greater than the applicable limit at the test frequencies.

7. ABBREVIATIONS

AD :	Applicable Document
AOCS :	Attitude Orbital Control System
AVM :	Avionics Model
BB :	Broadband
BOL :	Beginning of life
BW :	Bandwidth
CE :	Conducted Emission
CM :	Common Mode
CQM :	Cryogenic Qualification Model
CS :	Conducted Susceptibility
CSG :	Centre Spatial Guyanais
DC :	Direct Current
DM :	Differential Mode
EGSE :	Electrical Ground Support Equipment
EMC :	Electromagnetic Compatibility
EMI :	Electromagnetic Interference
EQM :	Engineering and Qualification Model
ESA :	European Space Agency
FIRST :	Far InfraRed and Submillimeter Telescope
FM :	Flight Model
HIFI :	Heterodyne Instrument for FIRST
IID :	Instrument Interface Document
ISO :	Infrared Space Observatory
LCL :	Latch Current Limiter
LV :	Launch vehicle
NB :	Narrowband
PACS :	Photoconductor Array Camera and Spectrometer (FIRST)
PFM :	ProtoFlight Model
PLM :	Payload Module
RD :	Reference Document
RE-E :	Radiated Emission E-field
RE-H :	Radiated Emission H-field
RF :	Radio Frequency
r.m.s. :	Root Mean Square
RS-E :	Radiated Susceptibility E-field
RS-H :	Radiated Susceptibility H-field
S/C :	Spacecraft
SPIRE :	Spectral Photometer Imaging Receiver
STD :	Standard
SVM :	Service Module
TBC :	To Be Confirmed
TBD :	To Be Defined
TM :	Telemetry
UUT :	Unit Under Test
VEB :	Vehicle Equipment Bay
WU :	Warm Unit

END OF DOCUMENT