



**Herschel-SPIRE**  
**Interface Control Document**  
**BDA**  
**SPIRE-JPL-PRJ-001181**

<p><b>James J. Bock</b> SPIRE Co-Investigator Jet Propulsion Laboratory, Pasadena, USA</p>	<p><b>Matthew J. Griffin</b> SPIRE Principle Investigator Cardiff University, Wales, UK</p>
<p><b>Bruce Swinyard</b> Spire Instrument Scientist Rutherford Appleton Laboratory, Oxfordshire, UK</p>	<p><b>John Delderfield</b> SPIRE Systems Engineer Rutherford Appleton Laboratory, Oxfordshire, UK</p>
<p><b>Gerald Lilienthal</b> U.S. SPIRE Detector Project Element Manager Jet Propulsion Laboratory, Pasadena, USA</p>	<p><b>Kenneth J. King</b> SPIRE Project Manager Rutherford Appleton Laboratory, Oxfordshire, UK</p>



## Table of Contents

1	SCOPE.....	4
2	APPLICABLE DOCUMENTS .....	4
3	APPLICABLE ICDs .....	4
4	REFERENCE DOCUMENTS .....	4
5	LIST OF ACRONYMS .....	5
6	FUNCTIONAL INTERFACE .....	6
6.1	FUNCTIONAL DESCRIPTION.....	6
7	MECHANICAL INTERFACE.....	7
7.1	FASTENER DATA .....	7
7.2	ELECTRICAL CONNECTOR MECHANICAL IDENTIFICATION.....	9
7.2.1	<i>BDA</i> s.....	9
7.2.2	<i>JFET</i> modules.....	10
7.2.3	<i>FPU RF Filter</i> (s).....	11
8	BDA MECHANICAL STRUCTURAL INTEGRITY.....	12
8.1	PART DESCRIPTION:.....	12
8.2	FEA SUMMARY.....	12
8.2.1	<i>FEA APPROACH</i> .....	13
9	THERMAL INTERFACE.....	<b>ERROR! BOOKMARK NOT DEFINED.</b>
9.1	BDA ASSEMBLY CONDUCTION.....	<b>ERROR! BOOKMARK NOT DEFINED.</b>
9.2	CROSS-SECTION (MM <sup>2</sup> ) OF MATERIALS FOR BDA-TO-FPU CABLES:.....	15
9.3	CROSS-SECTION (MM <sup>2</sup> ) OF MATERIALS FOR FPU-TO-JFET CABLES:.....	15
10	ELECTRICAL INTERFACE.....	16
11	MATERIAL AND PROCESS DESCRIPTION.....	17
11.1	MATERIALS IDENTIFICATION AND USAGE LIST__NON METALLIC .....	17
11.2	MATERIALS IDENTIFICATION AND USAGE LIST__METALLIC MATERIALS.....	20
	MATERIALS IDENTIFICATION AND USAGE LIST - PROCESSES .....	21
11.4	MATERIALS IDENTIFICATION AND USAGE LIST - PROCEDURES .....	22
11.5	ELECTRONIC PARTS.....	23

## 1 Scope

The purpose of this document is to complete the information about SPIRE instrument interfaces which are not included in the Interface Control Drawings listed as Applicable ICDs. These Interface Control Drawings shall take precedence if they conflict with this document. All this interface information is transferred under ITAR agreement between JPL and PPARC and between ESA and NASA according to the following restrictions:

### Restrictions for ESA:

This technical data is export controlled under U.S. law and is being transferred by JPL to ESA for use exclusively on the Herschel SPIRE project. The information may not be used for any other purposes, and shall not be re-transferred or disclosed to any other party without the prior written approval of NASA.

### Restrictions for PPARC:

This technical data is export controlled under U.S. law and is being transferred by JPL to PPARC pursuant to the NASA / PPARC Letter of Agreement which entered into force on December 2, 1999. This technical data is transferred to PPARC for use exclusively on the NASA/PPARC SPIRE on FIRST cooperative project, may not be used for any other purpose, and shall not be re-transferred or disclosed to any other party without the prior written approval of NASA.

## 2 Applicable Documents

Item	Doc. Number	Document Name
AD1	SCI-PT-IIDB/SPIRE-02124	Herschel/Planck Instrument Interface Doc. Part B
AD2	SPIRE-RAL-PRJ-000608	Harness Definition Document
AD3	SPIRE-RAL-PRJ-000617	ICD Structure - Mechanical I/F
AD3	SPIRE-RAL-DWG-000646	SPIRE Instrument Block Diagram
AD4	SPIRE-JPL-PRJ-000456	Detector Subsystem Specification Document

## 3 Applicable ICDs

Item	Doc. Number	Document Name
ICD1	10209721	BDA, Interface Control Drawing
ICD2	10209722	JFET Module, Interface Control Drawing
ICD3	10209723	FPU RF Filter, Interface Control Drawing
ICD4	10209725	Wiring Diagram, Interface Control Drawing
ICD5	10209726	Thermal Control, Interface Control Drawing

## 4 Reference Documents

Item	Doc. Number	Document Name
REF1		Wire length and routing ICD (MSSL)
REF2		Sub-millimeter filter materials (Cardiff)
REF3		The SPIRE Instrument for Herschel

## 5 List of Acronyms

AD	Applicable Document
BDA	Bolometer Detector Assembly
Co-I	Co-Investigator
CQM	Cryogenic Qualification Model
ESA	European Space Agency
FEA	Finite Element Analysis
Herschel	Name for Far Infrared and Submillimeter Telescope
HSJFP	Herschel SPIRE J-FET Unit (Photometer)
HSJFS	Herschel SPIRE J-FET Unit (Spectrometer)
HSDCU	Herschel SPIRE Detector Control Unit
HSFCU	Herschel SPIRE FPU Control Unit
FPU	Focal Plane Unit
FS	Flight Spare
FTS	Fourier Transform Spectrometer
GSE	Ground Support Equipment
ICD	Interface Control Document
IID-A	Instrument Interface Document (Part A)
IID-B	Instrument Interface Document (Part B)
JFET	Junction Field Effect Transistor
JPL	JET Propulsion Laboratory
MoU	Memorandum of Understanding
NASA	National Aeronautics and Space Agency
PA	Product Assurance
PDR	Preliminary Design Review
PFM	Proto-Flight Model
PI	Principal Investigator
PPARC	Particle Physics and Astronomy Research Council
QMW	Queen Mary and Westfield College
RAL	Rutherford Appleton Laboratory
RD	Reference Document
SPIRE	Spectral and Photometric Imaging Receiver
SVM	Service Module
TBC	To Be Confirmed
TBD	To Be Decided

## 6 Functional Interface

### 6.1 Functional Description

SPIRE, the Spectral and Photometric Imaging Receiver, is a bolometer camera and spectrometer for ESA's Herschel satellite. Herschel will give the scientific community access to a large space-borne far-infrared and submillimeter telescope equipped with a suite of instruments for imaging photometry and spectroscopy. As Herschel is an observatory mission, the design and scientific performance of its payload is a matter for oversight by ESA on behalf of the scientific community. ESA has established the Herschel Science Team to oversee and monitor the development and scientific optimisation of Herschel. Matters affecting significantly the scientific performance of SPIRE must be referred to the Herschel Science Team.

The design and scientific capabilities of SPIRE are described in more detail in *The SPIRE Instrument for Herschel* [REF5]. The main elements of the SPIRE instrument are shown schematically in Figure 1.

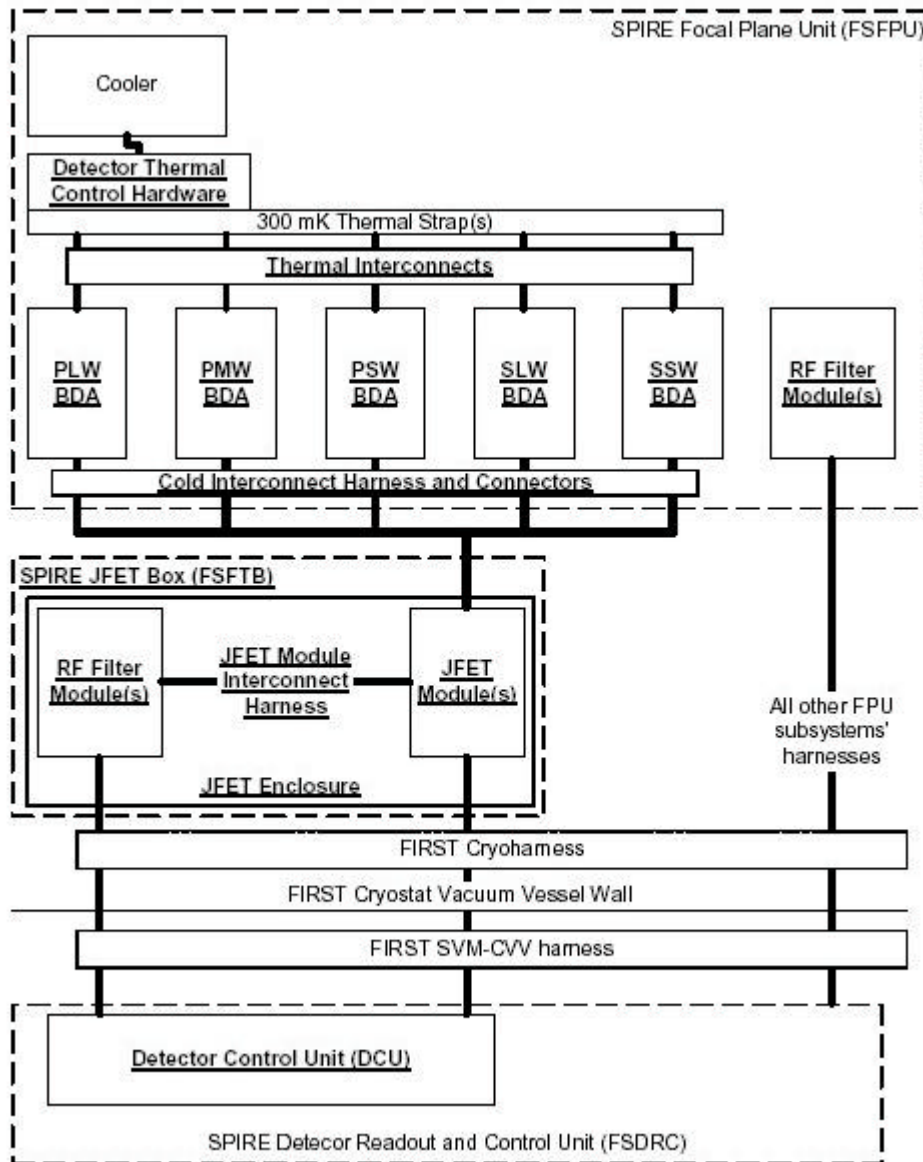

**Figure 1: Functional block diagram of SPIRE**

For a more detailed picture see [AD3].

## 6.2 Mechanical Interfaces

The mechanical mounting and interface features for each assembly are shown in their individual Interface Drawings, ICD1-3.

## 6.3 Fastener Data

Unified threadform screws are MMSL(UK) provided, but all the remainder of these items are JPL furnished.

Each Bolometer Detector Array (BDA) is secured in place using 4 No. 6-32 UNF screws, 4 No. 6 washers, and torqued as specified in [REF6]. Note that torques depend on design of MSSL side of interface.

Each BDA bolts to the 300 mK thermal strap by 2 M2.0 screws, a Belleville spring stack, and torque to 0.21 NM as per [REF6]

Each JFET Module Assembly is secured in place using 10 M2.5 screws, 6 M2.5 washers, and torque to 0.46 NM on threaded inserts. Through holes are torqued as specified in [REF7].

The RF Filter Module Assembly may be secured in place with 4 ST12391-1 studlocks and torqued to 2 in-lbs as per [REF8].

#### **6.4 Dynamic stability**

The suspended parts of the BDA have 1mm of permitted movement from their nominal position before hitting bump stops. This is not to imply that they should ever make such a contact.

However the suspended parts can statically in 0g be up to 0.5mm in x, y, and/or z away from nominal w.r.t. the 1.7K housings.

The bump stops are not set up to be 1mm from the actual static position . Therefore, 1.5mm movement in X, Y and Z is needed as a dynamic envelope around the 300mK parts shown in the drawings.

Clearly the BDA suspensions act symmetrically about their suspended centres of mass. Since the Kevlar tension remains at ~30 lbs weight, ~130 Newtons, analysis estimates that the suspended part moves \*\*TBC mm in the direction of a one G static force applied to its C. of G. without rotation to first order. The mass of the suspended part of each BDA can to a very good approximation be obtained by taking the overall mass tabulated in sheets 5-7 of [ICD1] and subtracting \*\*TBC grams, where \*\*TBC=the mass of the 1.7K assembly.



## 6.5 Electrical Connector Mechanical Identification

### 6.5.1 BDAs

Each BDA has six possible connector positions J1-J6 as shown in [ICD1]. Not all the positions are used on every BDA, and the unused ones shall either be R.F. tight blanked or not machined through in the first place.

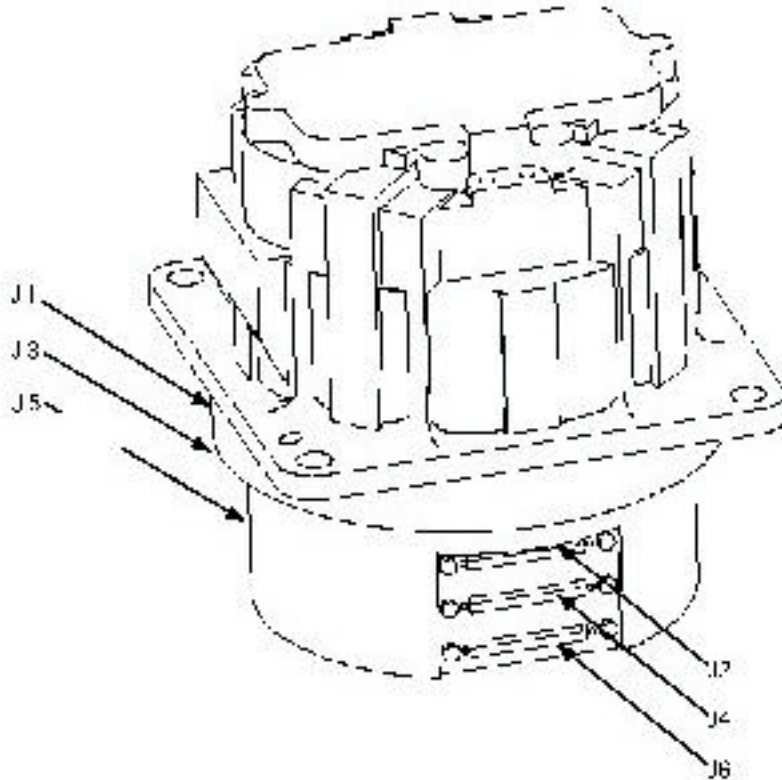

For each of the 5 BDA types, sheets 5-7 of [ICD1] show a data table which, amongst other information, identifies the BDA type number for each wavelength and photometer/spectrometer, and defines which out of J1 to J6 are used. Locations J1-J6 are labelled with epoxy ink, see materials list. Pin one locations will be noted on the ICD drawing.

All BDA connectors are Nanonics type STM 051 M6SN

### 6.5.2 JFET modules.

JPL's JFET Filter modules are assembled into two RAL provided racks, two modules making the HSJFS for the spectrometer and six making the HSFFP for the photometer. Electrically all JFET modules are nominally identical, each containing two JFET membrane PCBs, excepting the matter of which JFET pair(s) are selected to be unused. Connectors are as follows and will be enumerated on the rack by RAL. Serial numbers for the JFETs will be labelled with epoxy ink, see the materials list. This configuration follows [AD3]. Wiring diagram for JFETS is shown on ICD #10209725.

<b>BDA</b>	<b>Fharness</b>	<b>JFET Rack I/P</b>	<b>JFET Unit/J</b>	<b>JFET Rack O/P</b>	<b>C harness</b>
PSW J1	1	HSJFP J29	P1 J06/J01/J02	HSJFP J1/2	9
PSW J2	2	HSJFP J30	P2 J08/J03/J04	HSJFP J3/4	9
PSW J3	3	HSJFP J31	P3 J06/J01/J02	HSJFP J5/6	8
PSW J4	4	HSJFP J32	P4 J08/J03/J04	HSJFP J7/8	8
PSW J5	5	HSJFP J33	P5 J06/J01/J02	HSJFP J9/10	7
PSW J6	6	HSJFP J34	P6 J08/J03/J04	HSJFP J11/12	7
PLW J5	7	HSJFP J35	P7 J06/J01/J02	HSJFP J13/14	6
PLW J6	8	HSJFP J36	P8 J08/J03/J04	HSJFP J15/16	6
PMW J1	9	HSJFP J37	P9 J06/J01/J02	HSJFP J17/18	5
PMW J2	10	HSJFP J38	P10 J08/J03/J04	HSJFP J19/20	5
PMW J3	11	HSJFP J39	P11 J06/J01/J02	HSJFP J21/22	4
PMW J4	12	HSJFP J40	P12 J08/J03/J04	HSJFP J23/24	4
SSW J5	13	HSJFS J11	S1 J06/J01/J02	HSJFS J1/2	2
SSW J6	14	HSJFS J12	S2 J08/J03/J04	HSJFS J3/4	2
SLW J5	15	HSJFS J13	S3 J06/J01/J02	HSJFS J5/6	1
Tcontrol	28	HSJFS J14	S4 J08/J03/J04	HSJFS J7	2 to I4+

Reading in the same sequence as the table, the JFET 15way filtered connectors HSJFP 41-46, HSJFP 47-52, HSJFS 15-16 couple to HSJFP 25&27, HSJFP26&28 and HSJFS9&10 respectively using three JPL supplied copper harnesses that may be left connected to the racks. These route the JFET power, bias and heater wiring.

### 6.5.3 FPU RF Filter(s)

JPL's RF Filter Modules are assembled into one RAL provided rack. This rack will hold all 12 modules. Electrically all RF modules are nominally identical servicing a single 37 way MDM connector pair. Connectors will be shown on the assembled rack. RAL will provide for the labelling of the modules in the housing. JPL will enumerate serial numbers on the modules upon delivery using epoxy ink, see materials list. Wiring diagram for RF Filters is shown on ICD #10209723.

## 7 BDA Mechanical Structural Integrity

To state the matter simply, JPL has satisfied its engineers that the elements suspended within BDA units will remain in place before and after launch and thus the unit will comply with [ICD1]. The situation is as follows.

### 7.1 PART DESCRIPTION:

The BDA comprises two sections. The first a 1.7 Kelvin outer structure, which mounts to the SPIRE detector boxes via adaptor plates. The components of the 1.7 Kelvin structure are the Flexure Ring, Invar Suspension Rings, and four Vespel Posts.

The second section is a 300milli-Kelvin inner structure consisting of the Top Ring, Spacers, Bottom Ring, Cover Plate, and the Feedhorn. It is thermally isolated from first by two Kevlar suspension cables. Kevlar was chosen for its low thermal conductance and high strength. This inner structure includes the silicon bolometric thermal detectors.

The Kevlar suspension cable is preloaded to ~30 pounds weight  $\pm 20$  pounds at room temperature according to JPL internal procedures. This includes verification of the tension achieved at room temperature. The design gives a nominally constant tension in the Kevlar cables during thermal transition.

### 7.2 FEA SUMMARY

The BDA is analyzed to the Design and Manufacture requirements specified in the Detector Subsystem Specification document (Ref. 1). The specification states that the BDA is to survive a 100G qualification quasi-static load in conjunction with load derived from a room temperature to 90 Kelvin thermal transition. Although the requirement states the minimum temperature during qualification testing is to be 90 Kelvin, this analysis uses the thermal transition to the flight operating temperature of .3 Kelvin. This was done to assess the structural integrity of the BDA when subjected to flight thermal loading.

The major structural components all exhibited positive margins of safety with +.35 for the Flexure Ring being the lowest. Likewise, all fasteners, alignment pins, and shear pins exhibited positive margins of safety with +1.02 being the lowest for the shear pins that connect the Flexure Ring to the top Invar Suspension Ring. All joints exhibited factors of safety in excess of one, with 1.15 being the lowest for the pulley-to-Bottom Ring connection.

### 7.2.1 FEA APPROACH

A finite element model was created to solve for stress in each structural component, quantify loads in each joint and fastener, and determine the mass participation/frequency for each resonant mode. MSC/NASTRAN was used in solving for the aforementioned items.

#### 7.2.1.1 FEA Load Case Results

The following table summarizes the output of the FEA analysis.

Part	Worst Load Case	Stress (VM)	F.S. (Yield)	F.S. (Ult.)	F <sub>Yld</sub>	F <sub>ult</sub>	Failure Mode	MS (Yield)	MS (Ult.)
Flexure Ring	100G (.707,0,..707),P,T	33,823 psi	1.25	1.4	57,000 psi	68,000 psi	Von Mises	<b>0.35</b>	0.44
Top Ring	100G (.707,0,..707),P,T	16,828 psi	1.25	1.4	70,000 psi	90,000 psi	Von Mises	2.33	2.82
Invar Rings	100G (0,-1..0.),P,T	14,611 psi	1.25	1.4	70,000 psi	90,000 psi	Von Mises	2.83	3.40
Light Can	100G (.707,0,..707),P,T	4,135 psi	1.25	1.4	36,000 psi	42,000 psi	Von Mises	5.96	6.26
Spacers	100G (.707,0,..707),P,T	11,485 psi	1.25	1.4	70,000 psi	90,000 psi	Von Mises	3.88	4.60
Cover Plate (P/LW & S/LW)	100G (.707,0,..707),P,T	15,291 psi	1.25	1.4	70,000 psi	90,000 psi	Von Mises	2.66	3.20
Bottom Ring	100G (.707,0,..707),P,T	17,984 psi	1.25	1.4	70,000 psi	90,000 psi	Von Mises	2.11	2.57
Kevlar Cable	100G (.707,0,..707),P,T	139,699 psi	N/A	2.0	N/A	400,000 psi	Tension	N/A	<b>0.43</b>

VM = Von Mises Stress  
 P = 29lb. Kevlar Cable Preload  
 T = Thermal Transition form 70 °F to -460 °F  
 N/A = Not Applicable

T

Table 1: Margin of Safety Summary for BDA parts

Fastener/Pin Location	Load Case	FSult	Failure Mode	M.S. (ult)
Light Can to Flexure Ring	100G RSS, P, T	1.4	Bolt Tension-Shear Interaction	1.81
Bottom Ring to Cover Plate	100G RSS, P, T	1.4	Bolt Tension-Shear Interaction	1.85
Spacer to Top Ring & Bottom Ring	100G RSS, P, T	1.4	Bolt Tension-Shear Interaction	1.56
Spacer to Top Ring - Horiz Align Pins	100G RSS, P, T	1.4	Bolt Tension-Shear Interaction	2.20
Flexure Ring to BDA Mounting Structure	100G RSS, P, T	1.4	Bolt Tension-Shear Interaction	1.50
Spacer to Bottom Ring Align Pins	100G RSS, P, T	1.4	Bolt Tension-Shear Interaction	2.57
Flexure to Invar Ring Shear Pins	100G RSS, P, T	1.4	Bolt Tension-Shear Interaction	<b>1.02</b>
Pulley Fasteners	100G RSS, P, T	1.4	Bolt Tension-Shear Interaction	1.24

RSS = Root-Sum-Square  
 P = 29lb. Kevlar Cable Preload  
 T = Thermal Transition form 70 °F to -460 °F

Table 2: Fastener Margin of Safety Summary

Joint Location	Load Case	Failure Mode	Fbry # (psi)	Fbru # (psi)	FS(yld)	FS(ult)
Light Can to Flexure Ring	100G RSS, P, T	Bearing	97000	132000	5.68	6.90
Bottom Ring to Cover Plate	100G RSS, P, T	Bearing	* 70000	* 90000	5.49	6.30
Spacer to Top Ring & Bottom Ring	100G RSS, P, T	Bearing	* 70000	* 90000	N/A	HIGH
Spacer to Top Ring - @ Horiz Align Pins	100G RSS, P, T	Bearing	* 70000	* 90000	HIGH	HIGH
Flexure Ring to BDA Mounting Structure	100G RSS, P, T	Bearing	81000	103000	HIGH	HIGH
Spacer to Bottom Ring - @ Align Pins	100G RSS, P, T	Bearing	* 70000	* 90000	HIGH	HIGH
Flexure to Invar Ring - @ Shear Pins	100G RSS, P, T	Bearing	81000	103000	2.74	3.11
Bottom Ring Pulleys	100G RSS, P, T	Bearing	* 70000	* 90000	N/A	1.15
Top Ring Pulleys	100G RSS, P, T	Bearing	* 70000	* 90000	N/A	9.31
Invar Ring Pulleys	100G RSS, P, T	Bearing	* 70000	* 90000	N/A	6.58

RSS = Root-Sum-Square

P = 29lb. Kevlar Cable Preload

T = Thermal Transition from 70 °F to -460 °F

# Proper e/D value used

\* Assumption: Fbru and Fbry are taken as Ft<sub>u</sub> and Ft<sub>y</sub> respectively. This is conservative since actual bearing values are typically 1.5 times higher.

N/A = Not Applicable. e/D was < 1.5 and required a lug analysis. Lug analyses are ultimate failure checks only.

Table 3: Joint Factor of Safety Summary

## 8 Thermal Interface

This information is in addition to that in {ICD6}.

The following are physical interface data so the BDAs that meet their thermal load values given in [AD4].

### 8.1 BDA assembly conduction.

The area to length aspect ratios (A/L in mm) of materials linking the BDA 300mK sections to the 1.7K sections, the first three being electrical harnesses, are as follows:-

Array	Constantin	Kapton	Adhesive	Kevlar
P/LW	< $1.9 \times 10^{-3}$ [ $1.5 \times 10^{-3}$ ]	< 0.06 [0.05]	< 0.04 [0.02]	< 0.25 [0.15]
P/MW	< $3.9 \times 10^{-3}$ [ $3.1 \times 10^{-3}$ ]	< 0.13 [0.11]	< 0.09 [0.04]	< 0.25 [0.15]
P/SW	< $5.8 \times 10^{-3}$ [ $4.6 \times 10^{-3}$ ]	< 0.19 [0.16]	< 0.13 [0.06]	< 0.25 [0.15]
S/LW	< $1.0 \times 10^{-3}$ [ $0.8 \times 10^{-3}$ ]	< 0.03 [0.03]	< 0.02 [0.01]	< 0.25 [0.15]
S/SW	< $1.9 \times 10^{-3}$ [ $1.5 \times 10^{-3}$ ]	< 0.06 [0.05]	< 0.04 [0.02]	< 0.25 [0.15]

[] refer to nominal values

The average thermal length is 33 mm for the electrical harnesses and, 23 mm for Kevlar suspensions.

### 8.2 Cross-section (mm<sup>2</sup>) of materials for BDA-to-FPU cables:

Manganin	Stainless	PFA
.329	1.168	2.65

### 8.3 Cross-section (mm<sup>2</sup>) of materials for FPU-to-JFET cables:

Manganin	Stainless	PFA	Constantin RF shield
.329	1.168	2.65	

## 9 Electrical Interface

This information is in addition to that given in JPL's [ICD3] and [ICD5].

The overall configuration of BDAs, JFETs and harnesses is given in [AD2].

Each BDA electrical bolometer signal is a differential signal taken directly from the ends of the bolometer element. A quiet symmetric AC voltage bias, accurately symmetrical about ground, is supplied to each detector array. The bolometer elements are each current biased from this AC bias by two 300mK 10M $\Omega$  resistors from a resistor array integral within the BDA. The A-side of each signal is connected to the positive AC bias polarity, and the B-side is connected to the negative polarity.

16 cables carry bolometer signals, detector bias and ground between the BDAs and the JFET modules. Each of these cables are divided into two sections, one running from the JFET module to the 4 K wall of the FPU, and one running from the FPU to the BDA. The two sections connect electrically at the FPU wall. The cables must be RF shielded from the JFET module to the FPU wall to maintain the electrical continuity of the Faraday cage.

The JFET module provides differential power amplification at a little less than unity voltage gain for the bolometer signals. The electrical interface consists of input signals from the bolometers, and output signals to the ESA-supplied cryo-harness. The JFET modules require power (Vdd, Vss) and heater supply for operation. The module also passes detector bias and ground along to the bolometers. The JFET module is electrically integral to the cryogenic Faraday cage, and thus provides RF filtering of all electrical connection passing through the Faraday cage. The RF filters are integral to the JFET module.

JPL is also providing cables connecting the 15-way MDM inputs from the JFET modules to the ESA cryoharness. The wiring of these cables is defined in [AD2].

The electrical interface shown in drawing 10209725 describes the wiring of detector channels through the BDA nano connector interface, BDA-to-JFET cables, through JFET amplifiers, out to the 25-way MDM output connectors on the JFET module. All shielding and ground connections are specified in this drawing. This ICD must be consistent with the Harness Definition Document.

JPL is also providing RF filter modules for filtering cables at the cryogenic Faraday cage required by other subsystems. The electrical interface for the RF filter modules is shown in drawing 10209723.



## 10 Material and Process Description

### 10.1 Materials Identification and Usage List\_\_Non Metallic

Item No.	Material Description/ Brand Name Supplier	Application	Material Specifications	Thermal Vacuum Stability(%)	JPL Rating <sup>1</sup>	Comments
1	Vespel, Dupont SP1 Unloaded	Structural Support		TML = 1.09 VCM= 0.00 WVR=0.40	1	
2	Vespel, Dupont SP3 Molybdenum Loaded	Snubber		TML = VCM = WVR =		Need to get material's data
3	Kevlar 29 Yarn, Dupont Braided. Denier????	Tension Member		TML =3.13 VCM=0.19 WVR=1.76	3	Thermal vacuum bakeout required. Is a bakeout currently planned? How much material will be used?
4	Stycast 2850 FT	Adhesive		TML = VCM= WVR=	?	Need to get materials data
5	EC2216	Adhesive		TML =0.97 VCM=0.02 WVR=0.32	2	Do not use material if hardware will be exposed to temperatures greater than 80°C
6	JFET boards (polyimide)			TML = VCM= WVR=		
7	RF filter connector potting			TML = VCM= WVR=		

Item No.	Material Description/ Brand Name Supplier	Application	Material Specifications	Thermal Vacuum Stability(%)	JPL Rating <sup>1</sup>	Comments
8	Diallyl Phthalate	Connector Insulator	MIL-M-14G Type SDG-F			
9	Chomerics EMI/EMP Gasket	RF gasket material	MIL-G-83528 Type A			
10	Teflon	Wire Insulation	ST 11478			
11	Epoxy	Cable potting.	TBD	TML = VCM= WVR=		
12	Epoxy ink			TML = VCM= WVR=		
13	Urlane 5750A/B	Conformal Coating	BS515376	TML = VCM= WVR=		
14	Silicon			TML = VCM= WVR=		
15	Silicon Nitride			TML = VCM= WVR=		
16	Germanium			TML = VCM= WVR=		
17	Kapton	Rigid Flex Cable Insulation	IPC-FC-232C/1	TML = VCM= WVR=		
18	Acrylic adhesive	Fabricate Rigid Flex Cable	IPC-FC-232C/1	TML = VCM= WVR=		
19	Polyimide Resin Glass Base	Fabricate Rigid Flex Cable	IPC-4101/40	TML = VCM=		

Item No.	Material Description/ Brand Name Supplier	Application	Material Specifications	Thermal Vacuum Stability(%)	JPL Rating <sup>1</sup>	Comments
				WVR=		
20	Solder mask	Fabricate Rigid Flex Cable	BS502673	TML = VCM= WVR=		
21	Armstrong C7/W	Via Fill	D8208	TML = VCM= WVR=		
22	Sub-millimeter filter materials		Cardiff	TML = VCM= WVR=		Explicit materials the responsibility of Cardiff.
23	Epoxy	Array to backshort		TML = VCM= WVR=		
24	Epoxy	Feedhorn	Custom Microwave	TML = VCM= WVR=		
25	Assorted electronics bits (thin resistors, ferrite in inductors, etc...)			TML = VCM= WVR=		

1) 1 - acceptable, 2 - qualified acceptable, 3 - provisionally acceptable, 4 - unacceptable

## 10.2 Materials Identification and Usage List\_\_Metallic Materials

Item No.	Material Description/ Condition	Application	Material Specifications	Stress Corrosion Cracking Rating	JPL Rating <sup>1</sup>	Comments
1	Invar 36	Structural Elements	ASTM B753-T36	A	1	
2	Al 7075 T73	Structural Elements	SAE-AMS-QQ-A-225/9	1	1	
3	Al 6061 T651	Structural Elements	SAE-AMS-QQ-A-250/11	1	1	
4	A286 Stainless????	Fasteners		1	1	
5	303 CRES	Fasteners	AMS 5738	1	1	
6	Copper, 99.999% pure	Thermal Strap		A	1	Sort out annealing and keeping pure.
7	CDA 172	Clamps	B194	1	1	
8	Gold	Protective Plating	MIL-G-45204			
9	Nickel	Under Plating	QQ-N-290			
10	Indium	NTD Ge bonds				
11	Phosphor Bronze					
12	Copper	Wire Harness	ST 11478			
13	Manganin					
14	Constantin					
15	CRES Wire Braid	Cable Shield	AMS 5738			
16	BeCu	Connector Contacts	C17200			
17	Al	Connector shell	QQ-A-200/8			
18	SN63 Solder	Cable Assembly	QQ-S-571			
19	Nichrome	JFET source and load Resistors				Vacuum deposited oxide.
20	Aluminium	wirebonds	Purchase Order			
21	Gold	wirebonds	Purchase Order			
	Copper , Electroplate	Feed Horn	MIL-C-14550			

1) 1 - acceptable, 2 - qualified acceptable, 3 - provisionally acceptable, 4 - unacceptable

### 10.3 Materials Identification and Usage List - Processes

Item No.	Process	Specification	Materials Processed	Application	Rating <sup>1</sup>	Comments
1	Gold Plating	MIL-G-45204, Class 3, Type 3	Invar 36	Corrosion Protection, Thermal Conduction	1	
2	Gold Plating	MIL-G-45204, Class 3, Type 3	Copper	Thermal Conduction	1	
3	Passivation	FS 505146	303 CRES	Passivation	1	
4	Bonding	D-8208, Section 3.17, FP513414	Solithane 113/C113-300 Filled Polyurethane	Spot Bonding of Component Parts	1	
5	Bonding	BS515871, D-8208, Section 3.17	Scotch Weld 2216 B/A with Filler	Spot Bonding of Component Parts	1	
6	Workmanship	FS504040	ALL	Workmanship Standards for Mechanical Parts and Material	1	
7	Torque	ES504255	Fasteners	Torque Requirements, Threaded Fasteners	1	American Nation Standard
8	Solder Joint	D-8208, Section 3.14, FP513414	Cables/Connectors	Solder Joint	1	
9	Installation	D-8208, Section 3.12, FP513414	Connectors	Connector Installation – Rectangular Miniature		
10	Nickel plating	QQ-N-290	Invar 36	Corrosion Protection, Thermal Conduction		
11	Annealing	BS506336	Invar 36	Stress relief		
12	Parts vacuum bake out	AIDS	All Parts and Assemblies	Out gassing		
13	Wire bonding	Mil-STD-883	Gold	JFET and Detector Assembly		
14	Wire bonding	Mil-STD-883	Al	JFET Assembly		

15	Torque	ES517040		Torque Requirements, Threaded Fasteners		Metric fasteners
----	--------	----------	--	---	--	------------------

1 - acceptable, 2 - qualified acceptable, 3 - provisionally acceptable, 4 – unacceptable

#### 10.4 Materials Identification and Usage List - Procedures

Item No.	Process	Specification	Materials Processed	Application		Comments
1	Bolometer Array Lithography	AIDS/Traveller	Silicon	Bolometer Fabrication		
2	Bolometer Array chip attachment and etch	AIDS/Traveller		Bolometer Assembly		
3	JFET lithography	AIDS/Traveller		JFET Substrate Fabrication		
4	JFET die attach and etch	AIDS/D8208		JFET Module Assembly		
5	Load resistor lithography	AIDS/Traveller		Load Resistor Fabrication		
6	Back short fabrication	AIDS/Traveller		Detector Assembly		
7	BDA suspension assembly	AIDS/D8208		BDA Assembly		
8	Detector sub-assembly	AIDS/D8208		BDA Assembly		
9	BDA integration	AIDS/D8208		BDA Assembly		
10	JFET module assembly	AIDS/D8208		JFET Module Assembly		
11	Kapton cable assembly	AIDS/D8208		Detector Assembly		
12	BDA-JFET cable assembly	Purchase Order/Drawing		SPIRE Optical Bench		
13	Back harness cable assembly	AIDS/D8208		SPIRE Optical Bench		

14	RF filter assembly	Purchase Order/Drawing		SPIRE Optical Bench		
----	--------------------	---------------------------	--	---------------------	--	--

### 10.5 Electronic Parts

Part Name	Part Number	Specification	Remarks
Surface mount resistors			
JFET	U401		Balanced N-channel JFET die
Micro D Connector	M83513/01*	Mil-C-83513	
Filter Connector	FMD-2D-1N5PM	Mil-C-83513	Supplier Cristek
Jumper Connector			
Nanonics connectors		Mil-C-83513	Supplier Nanonics