	<b>SRef.: SPIRE-UCF-PRJ-001150</b> <b>CRef.: HSO-CDF-ICD-013</b> <b>Issue: 3.0</b> <b>Issue Date: 17<sup>th</sup> May 2004</b> <b>Page: 1 of 10</b>
		<b>Photometer Calibrator - Interface Control Document</b>

## Photometer Calibrator (PCAL)

### Interface Control Document

SPIRE Ref.: SPIRE-UCF-PRJ-001150

Cardiff Ref.: HSO-CDF-ICD-013

Issue: 3.0

Prepared by:	P. Hargrave		SPIRE Technical manager	UWC	Date: 17/05/04
Approved by:	I. Walker		Programme Manager	UWC	Date: 17/05/04
Agreed by:	D. Griffin		SPIRE Systems Engineer	RAL	Date:
Agreed by:	B. Swinyard		SPIRE Instrument Scientist	RAL	Date:
Agreed by:	E. Sawyer		SPIRE Project Manager	RAL	Date:
Agreed by:	P. Parr-Burman		SPIRE Project Manager	UKATC	Date:
Agreed by:	C. Cara		DRCU Engineer	CEA	Date:

Astronomy Instrumentation Group, Department of Physics & Astronomy, University of Wales, Cardiff, 5 The Parade, Cardiff CF24 3YB +44 (0)2920 876682	W:\Cardiff_workpackages\Configured_Documents\PCAL\PCAL_ICD_HSO_CDF_ICD_013_3_0.doc
---	--

## Update history

<b>Date</b>	<b>Version</b>	<b>Remarks</b>
7/9/01	1.0	First issue for DDR
6/02/02	2.0	Issue for IBDR
13/05/04	3.0	Issue for Flight Model Build 3.3 Updated interface drawing. 6.2 Clarification of BSM connector pin assignments

# List of Acronyms

Term	Meaning	Term	Meaning
AD	Applicable Document	IR	Infrared
ADC	Analogue to Digital Converter	IRD	Instrument Requirements Document
AIV	Assembly, Integration and Verification	IRTS	Infrared Telescope in Space
AME	Absolute Measurement Error	ISM	Interstellar Medium
AOCS	Attitude and Orbit Control System	JFET	Junction Field Effect Transistor
APART	Arizona's Program for the Analysis of Radiation Transfer	ISO	Infrared Space Observatory
APE	Absolute Pointing Error	LCL	Latching Current Limiter
ASAP	Advanced Systems Analysis Program	LIA	Lock-In Amplifier
ATC	Astronomy Technology Centre, Edinburgh	LVDT	Linear Variable Differential Transformer
AVM	Avionics Model	LWS	Long Wave Spectrometer (an instrument used on ISO)
BDA	Bolometer Detector Array	MAC	Multi Axis Controller
BFL	Back Focal Length	MAIV	Manufacturing, Assembly, Integration and Verification
BRO	Breault Research Organization	MCU	Mechanism Control Unit = HSMCU
BSM	Beam Steering Mirror	MGSE	Mechanical Ground Support Equipment
CBB	Cryogenic Black Body	M-P	Martin-Puplett
CDF	Cardiff, Department of Physics & Astronomy	NEP	Noise Equivalent Power
CDMS	Command and Data Management System	NTD	Neutron Transmutation Doped
CDMU	Command and Data Management Unit	OBS	On-Board Software
CDR	Critical Design Review	OGSE	Optical Ground Support Equipment
CEA	Commissariat a l'Energie Atomique	OMD	Observing Modes Document
CMOS	Complimentary Metal Oxide Silicon	OPD	Optical Path Difference
CoG	Centre of Gravity	PACS	Photodetector Array Camera and Spectrometer
CPU	Central Processing Unit	PCAL	Photometer Calibration source
CQM	Cryogenic Qualification Model	PFM	Proto-Flight Model
CVV	Cryostat Vacuum Vessel	PID	Proportional, Integral and Differential (used in the context of feedback control loop architecture)
DAC	Digital to Analogue Converter	PLW	Photometer, Long Wavelength
DAQ	Data Acquisition	PMW	Photometer, Medium Wavelength
DCU	Detector Control Unit = HSDCU	POF	Photometer Observatory Function
DDR	Detailed Design Review	PROM	Programmable Read Only Memory
DM	Development Model	PSW	Photometer, Short Wavelength
DPU	Digital Processing Unit = HSDPU	PUS	Packet Utilisation Standard
DSP	Digital Signal Processor	RAL	Rutherford Appleton Laboratory,
DQE	Detective Quantum Efficiency	RD	Reference Document
EDAC	Error Detection and Correction	RMS	Root Mean Squared
EGSE	Electrical Ground Support Equipment	SCAL	Spectrometer Calibration Source
EM	Engineering Model	SCUBA	Submillimetre Common User Bolometer Array
EMC	Electro-magnetic Compatibility	SED	Spectral Energy Distribution
EMI	Electro-magnetic Interference	SMEC	Spectrometer Mechanics
ESA	European Space Agency	SMPS	Switch Mode Power Supply
FCU	FCU Control Unit = HSFCU	SOB	SPIRE Optical Bench
FIR	Far Infrared	SOF	Spectrometer Observatory Function
FIRST	Far Infra-Red and Submillimetre Telescope	SPIRE	Spectral and Photometric Imaging Receiver
FOV	Field of View	SRAM	Static Random Access Memory
F-P	Fabry-Perot	SSSD	SubSystem Specification Document
EPGA	Field Programmable Gate Array	STP	Standard Temperature and Pressure
FPU	Focal Plane Unit	SVM	Service Module
FS	Flight Spare	TBC	To Be Confirmed
FTS	Fourier Transform Spectrometer	TBD	To Be Determined
FWHM	Full Width Half maximum	TC	Telecommand
GSFC	Goddard Space Flight Center	URD	User Requirements Document
HK	House Keeping	UV	Ultra Violet
HOB	Herschel Optical Bench	WE	Warm Electronics
HPDU	Herschel Power Distribution Unit	ZPD	Zero Path Difference
HSDCU	Herschel-SPIRE Detector Control Unit		
HSDPU	Herschel-SPIRE Digital Processing Unit		
HSFCU	Herschel-SPIRE FPU Control Unit		
HSO	Herschel Space Observatory		
IF	Interface		
IID-A	Instrument Interface Document - Part A		
IID-B	Instrument Interface Document - Part B		
IMF	Initial Mass Function		

# Table of Contents

1.	Scope .....	5
2.	Documents .....	5
2.1.	Applicable documents .....	5
3.	Mechanical Interface .....	5
3.1.	Inputs .....	5
3.1.1.	Resonance .....	5
3.1.2.	Scale factor .....	6
3.1.3.	Assumptions .....	6
3.2.	Outputs .....	6
3.3.	Interface drawings .....	6
4.	Thermal Interface .....	8
4.1.	Finish .....	8
4.2.	Surface Area .....	8
4.3.	Contact Force .....	8
5.	Optical Interface.....	8
6.	Electrical Interface .....	8
6.1.	Harness details.....	8
6.2.	BSM connector pin assignments .....	9
6.3.	Electrical drive requirements.....	10
6.3.2.	Drive current adjustability .....	10
6.3.3.	Maximum drive voltage.....	10
6.3.4.	Time constant .....	10
6.3.5.	Drive current stability.....	10
6.3.6.	Safety limits on the drive current .....	10
6.3.7.	Power supply redundancy .....	10
7.	Data Interface.....	10

# 1. Scope

The purpose of this document is to define the interfaces between the photometer calibrator (PCal) and SPIRE.

Note that this document is applicable to the CQM, flight model and flight spare versions of PCal.

## 2. Documents

### 2.1. *Applicable documents*

All applicable documents are recorded in the AD chapter of the CIDL (HSO-CDF-LI-029).

## 3. Mechanical Interface

### 3.1. *Inputs*

PCAL receives input vibrations from the BSM structure, at a high level during launch and at a low level during operation (spacecraft micro vibration environment).

The analysis in this section has been carried out by the ATC for the BSM structure (Ref. BSM ICD).

#### 3.1.1. Resonance

The principal resonant modes of the structure and the two suspended masses are presented below in Table 1. The BSM structural interface forms a stiff body. The first twelve structural modes were determined by finite element analysis.

FEA prediction for Response of structural interface		Approximate assembly response (see scale factor)
Mode	Frequency (Hz)	Frequency (Hz)
1	688	433
2	864	544
3	1781	1121
4	2715	1710
5	3058	1926
6	3284	2068
7	3345	2106
8	3614	2276
9	3957	2492
10	4097	2579
11	4677	2945
12	5185	3265
	mass of structure	291
	mass of assembly	734
	scaling for resonance	0.630

**Table 1: Structural Interface Principal Modes**

### 3.1.2. Scale factor

Pending a full resonant modes analysis, we may note that since the stiffness of the structural interface design remains unchanged, the assembly natural frequency scales as:

$$f_n = \frac{\sqrt{k/m}}{2}$$

$$\text{hence, } f_{n(\text{assy})} / f_{n(\text{struct})} = \sqrt{m_{\text{struct}} / m_{\text{assy}}}$$

The mass of the structure used for the FEA modes search was calculated at 291 gm, and the full assembly mass (excluding contingency, the baseplate and fasteners below the structure base) is predicted at 734 gm . This yields a scaling factor of ~ 0.63, used in Table 1.

### 3.1.3. Assumptions

As the structural response remains above 250 Hz it may be assumed to be stiff for subsequent analysis of the SPIRE structure and for transmission of SPIRE optical bench motion to PCAL.

## 3.2. *Outputs*

There are no mechanical outputs to the structure from this subsystem.

## 3.3. *Interface drawings*

The PCAL interface drawing is shown in Figure 1.

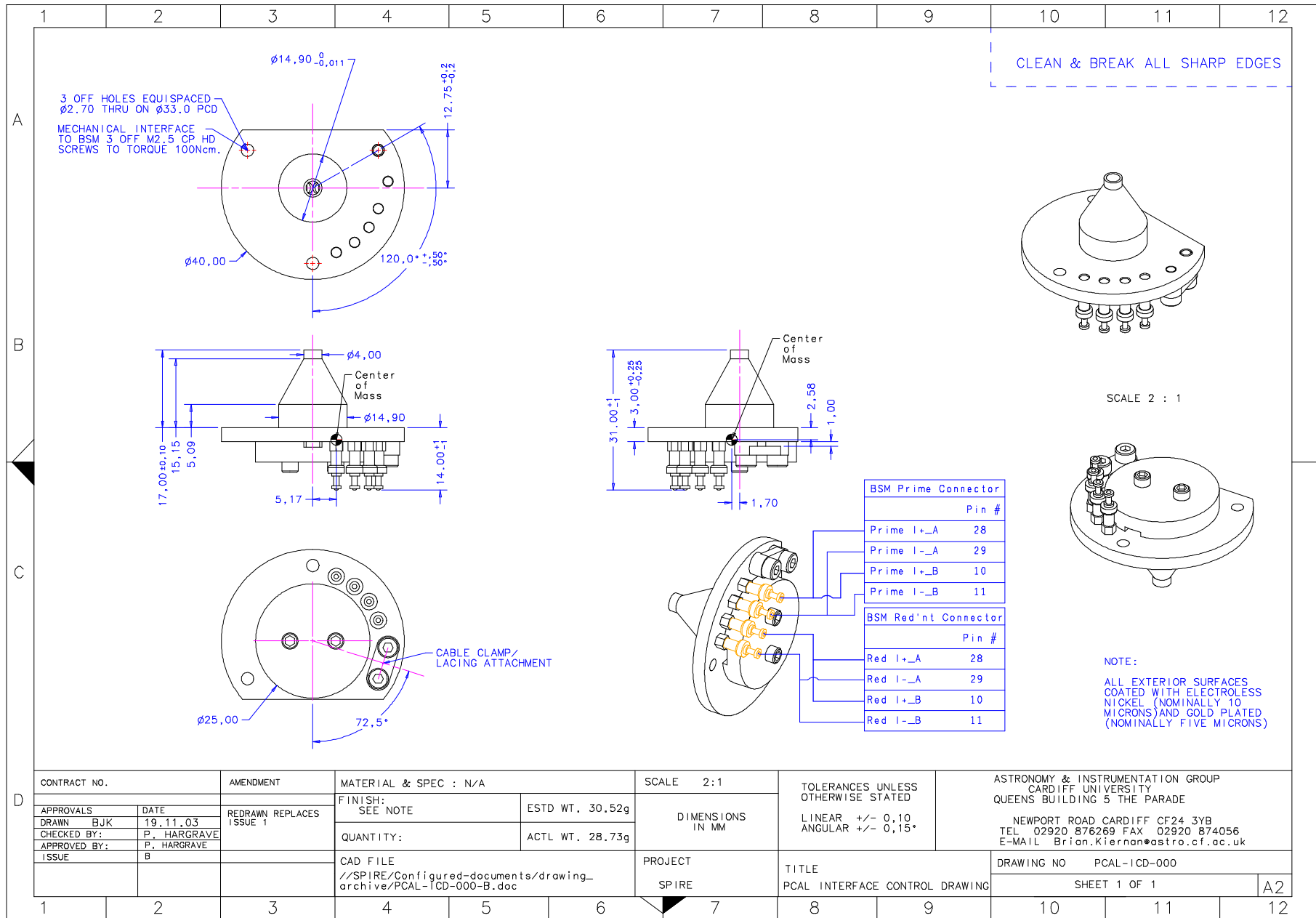

Figure 1 PCal interface drawing.

## 4. Thermal Interface

Cooling of PCAL is provided by contact to the BSM structure bulkhead.

### 4.1. Finish

The PCAL interface surface is aluminium alloy, grade 6061, coated with 10 microns (nominal) of nickel and 5 microns (nominal) of gold.

The BSM-PCAL interface surface on the BSM will be aluminium alloy, grade 6082, coated with Aluchrom-1200. The interface surface provides a precision central hole and three mounting holes, tapped M2.5, with locking inserts.

### 4.2. Surface Area

The contact surface area of the PCal-BSM interface is 2411 mm<sup>2</sup>.

### 4.3. Contact Force

At the contact face an approximate contact force of 1380 N will be developed by three M2.5 socket head screws torqued to 0.23 N-m

## 5. Optical Interface

The BSM mirror (M4) is positioned at an image of the Herschel primary mirror, and has a 2.8mm diameter hole at its centre. The PCal aperture is 3.0mm diameter, and is positioned approximately 6.5 mm behind the hole in M4.

## 6. Electrical Interface

### 6.1. *Harness details*

The four prime PCAL wires (part of the BSM/PCal prime harness) will be terminated on the two prime solder terminals. This harness will be duplicated for the redundant systems. The PCAL wiring will consist of an insulated, screened, twisted quad sub-harness. The maximum harness impedance requested for PCAL is 10 Ohms per wire. A schematic of the BSM prime connector wiring is shown in Figure 2. The redundant wiring will be an exact copy of this harness.



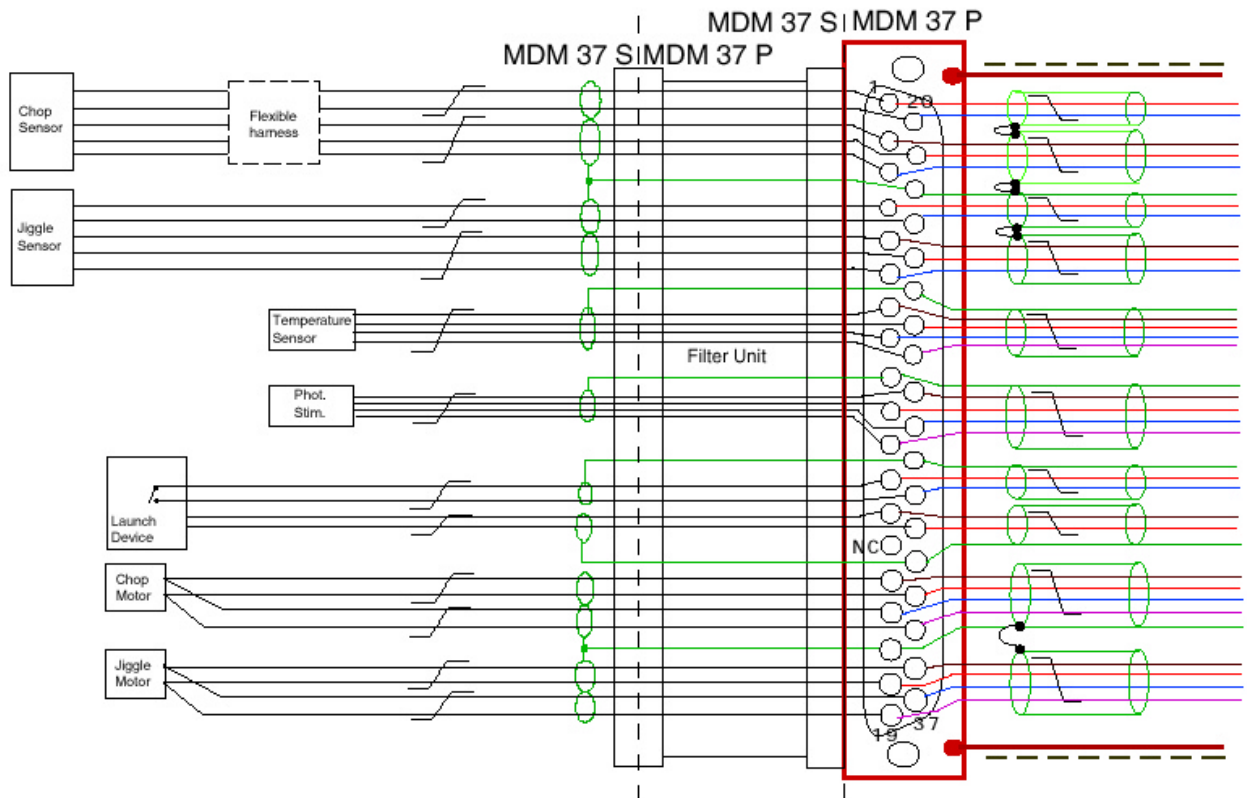

Figure 2 Details of BSM/PCAL harness (C11).

## 6.2. BSM connector pin assignments

See also **Figure 1** for PCal connections.

<b>BSM Prime connector Pin#</b>	<b>Label (in accordance with Harness Definition Document)</b>	<b>Function</b>
28	Prime I+ _A	Current drive
29	Prime I- _A	Current return
10	Prime I+ _B	Voltage sense +
11	Prime I- _B	Voltage sense -
<b>BSM Redundant connector Pin#</b>	<b>Label (in accordance with Harness Definition Document)</b>	<b>Function</b>
28	Red I+ _A	Current drive
29	Red I- _A	Current return
10	Red I+ _B	Voltage sense +
11	Red I- _B	Voltage sense -

### **6.3. Electrical drive requirements**

Current drive for PCAL in a four-wire configuration (to allow current drive and voltage monitoring) was agreed at the interface review in November 2001. The following specifications are derived to allow for final device impedances in the range 200-500  $\Omega$ :-

#### **6.3.1. Maximum drive current**

Maximum power is specified as 2mW (goal), but we may want to run at higher power. Therefore we have allowed for a maximum power dissipation of 10mW. Allowing for the case of a 200 $\Omega$  device, this gives a required drive current of 7mA.

#### **6.3.2. Drive current adjustability**

12-bit resolution (minimum) is required in the range 0 – 7mA. This will give a minimum of 1170 adjustment steps in the target operating range.

#### **6.3.3. Maximum drive voltage**

Assuming worst case ( $R=500\Omega$ ), the maximum drive voltage is 3.9V when delivering 7mA. The maximum expected voltage drop across the devices is 3.5V.

#### **6.3.4. Time constant**

The time constant associated with a PCAL current drive step should be less than 6ms.

#### **6.3.5. Drive current stability**

Required repeatability for calibrator radiant power is 1%. The stability and repeatability of the drive current should be within 5 $\mu$ A or 0.5% of the drive current, whichever is the greater.

#### **6.3.6. Safety limits on the drive current**

The specifications on what the warm electronics can provide will be such that the power dissipation in the calibrator can get very high, depending on the final value of the device impedance. Therefore, we require provision for the placement of a set-on-test resistor in the warm electronics, the value of which will be determined by the final value of the calibrator impedance.

#### **6.3.7. Power supply redundancy**

Two completely independent power supplies and voltage monitoring circuits are required for PCAL – 1 prime, 1 redundant.

## **7. Data Interface**

Normal operation of PCAL will involve the application of a pre-determined sequence of commands based on an OBS script under DPU control. Envisaged frequency of operation is no more than once per hour for a period of ~10 seconds.

**Table 2 Summary of software commands needed to control PCAL**

Command ID	Name	Description
PC2	SetPhCalBias	PCAL will be driven by a 12-bit DAC over the range 0 to 7mA. Therefore the software should allow for the commanding of 4096 current levels in the range 0 to 7mA.