

A-A

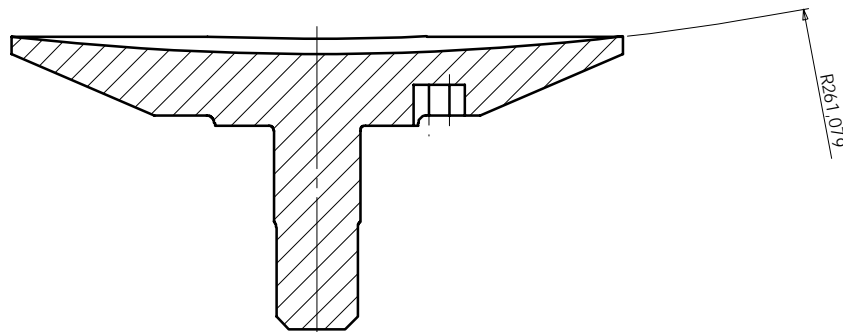
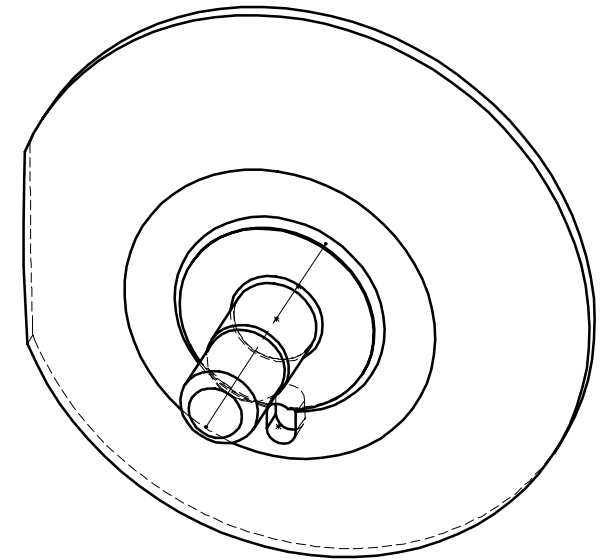

B-B

Matière	Surface	Tolerances :	Rugosité	Echelle	Poids
6061		+0,1 -0,1		2 : 1	<input checked="" type="checkbox"/>
				Numéro / Projet	
				SPIRE - HERSCHEL	
				Designation	
				Miroir SM10a	
				à 293 K	
				Numéro	Feuille No
				SPI.MIR.36.DD.01.1	1
01	Mod.	Date	Nom	Laboratoire d'Astronomie Spatiale	