



HERSCHEL / PLANCK

**General Design and Interface Requirements
(GDIR)**

H-P-1-ASPI-SP-0027

Product Code : 000 000

Rédigé par/ <i>Written by</i>	Responsabilité-Service-Société <i>Responsibility-Office -Company</i>	Date	Signature
Ivan BENILAN	System Engineer	28-Nov-2003	<i>Kil</i>
Vérifié par/<i>Verified by</i>			
Pascal RIDEAU	System Engineering Manager	29/11/03	<i>Rideau</i>
Hervé SAINCT	Science & Observation Advanced Projects Manager	8.12.03	<i>HS</i>
Approbation/<i>Approved</i>			
Christian MASSE	PA Manager	01/12/03	<i>Masse</i>
Jean-Jacques JUILLET	Project Manager	1/12/03	<i>JJ</i>

Data management : Christiane GIACOMETTI

Entité Emettrice : Alcatel Space - Cannes
(détentrice de l'original) :

GENERAL DESIGN AND INTERFACE REQUIREMENTS (GDIR)

REFERENCE : H-P-1-ASPI-SP-0027

DATE : 25-Nov-2003

ISSUE : 4.2

PAGE : 2/118

DISTRIBUTION / *DISTRIBUTION RECORD*

EXTERNAL DISTRIBUTION	For Information For Application For Approbation For Action For Acceptation	INTERNAL DISTRIBUTION	
ESA	For Information	HP team	X
ASTRIUM	For Application	P.Rideau	
ALENIA	For Application	Y.Roche	
CONTRAVES	For Application	I.Bénilan	
TICRA	For Application	K.Hibberd	
TECNOLOGICA	For Application	A.Luc	
PROTOTECH	For Application upon decision of B.Marchand	P.Couzin	
CSL	For Application upon decision of P.Armand	B.Collaudin	
OIP	For Application upon decision of Y.Pocchiola	Ph.Clavel	
RF Suitcase Contractor	For Application upon decision of O.Fratacci	B.Marchand	
APCO	For Application upon decision of O.Fratacci	B.Demolder	
		D.Montet	
		Y.Pocchiola	
		P.Armand	
		J.B.Riti	
		Ch.Bainier	
		M.Pastorino	
		O.Fratacci	
		J.M.Reix	
		Clf Documentation	
		Ch.Giacometti	Orig.

GENERAL DESIGN AND INTERFACE REQUIREMENTS (GDIR)

REFERENCE : H-P-1-ASPI-SP-0027

DATE : 25-Nov-2003

ISSUE : 4.2

PAGE : 3/118

ENREGISTREMENT DES EVOLUTIONS / *CHANGE RECORD*

Herschel / Planck			CHANGE RECORD	
ISSUE	REV.	DATE	MODIFICATIONS	APPROVAL
01		03/05/00	Initial issue	
	01	13/09/00	Page 15: update of Planck axes according to SRS	
02		31/10/00	All pages updated	
	01	15/06/01	Updated taking into account ESA and ALENIA comments	
	02	04/07/01	Updated table 4.5-2, GDME-070, section 4.7, and the two first pages of the IDS. Deleted figure 6.2-8.	
			Updated taking into account the changes in issue 2 of the SRS.	
03		27/07/01	Added new paragraph: 6.8.2.3Cryo-temperature acquisition. (see change bars)	
	Rev 1	12/11/01	<p>AD-8: old document title and reference replaced by updated one</p> <p>AD-37: PSS replaced by ECSS</p> <p>AD-38: updated Issue</p> <p>New paragraph 3.1.16 on debris</p> <p>GDME-190 modified in accordance with RID SVM-148 (spreading of mass growth potential over modules)</p> <p>GDME-280: updated preliminary design loads for electronic boxes in Herschel and Planck SVM in accordance with Minutes of Meeting H-P-ASPI-MN-544, dated 07/11/01</p> <p>GDME-360 modified in accordance with RID PLM-014 (wrong reference)</p> <p>GDEL-280: note added to answer RID SVM-040</p> <p>GDEL-350 modified in accordance with RID SVM-135 (spare pins)</p> <p>GDEL-580 modified in accordance with RID SVM-104 (maximum voltage reduced from 35V to 32 V)</p> <p>GDEL-585 modified in accordance with RID SVM-042 (ripple and spikes)</p> <p>GDEL-627 modified in accordance with RID SVM-104 (undervoltage protection)</p> <p>GDEL-685 deleted: covered by GDEL-660 (answer to RID SVM-041)</p> <p>§ 6.8.2.3: updated paragraph to define cryo temperature acquisition sensors</p>	

GENERAL DESIGN AND INTERFACE REQUIREMENTS (GDIR)

REFERENCE : H-P-1-ASPI-SP-0027

DATE : 25-Nov-2003

ISSUE : 4.2

PAGE : 4/118

Herschel / Planck			CHANGE RECORD	
ISSUE	REV.	DATE	MODIFICATIONS	APPROVAL
3	2	15-Feb-2002	<p><u>2. DOCUMENTS</u></p> <ul style="list-style-type: none"> · AD-1 : title corrected and date reference deleted. · AD-2 : issue and date references deleted. · AD-8 : issue reference deleted. <p><u>3. GENERAL DESIGN AND INTERFACE REQUIREMENTS</u></p> <ul style="list-style-type: none"> · GDGE-090 : updated according to SRS 2.1. · GDGE-230 : updated according to SRS 2.1. · ENVR-005 : updated according to SRS 2.1. · ENVR-030 : updated according to SRS 2.1. · ENVR-040 : updated according to SRS 2.1. · ENVR-180 : updated according to SRS 2.1. · GDGE-600 : typing error corrected according to MoM H-P-ASPI-MN-642, 27-Nov-2001. <p><u>4. MECHANICAL DESIGN AND INTERFACE REQUIREMENTS</u></p> <ul style="list-style-type: none"> · GDME-080 : "location of the " inserted after "nominal". · GDME-260 : traceability to SCMD-070 moved to the requirement GDME-260 itself. · GDME-280 : updated with Table 4-3 according to MoM H-P-ASPI-MN-909 dated 31-Jan, 1st, 4th, 5th & 8th-Feb-2002. · GDME-290 : updated according to MoM H-P-ASPI-MN-642, 27-Nov-2001. · GDME-310 : typing error corrected. · GDME-360 : "limit loads" replaced by "design loads" as agreed in the MoM H-P-ASPI-MN-642, 27-Nov-2001. · GDME-480 : note added after Table 4-13 according to MoM H-P-ASPI-MN-909 dated 31-Jan, 1st, 4th, 5th & 8th-Feb-2002. · GDME-570 : updated according to MoM H-P-ASPI-MN-909 dated 31-Jan, 1st, 4th, 5th & 8th-Feb-2002. · GDME-700 : updated according to SRS 2.1. <p><u>5. THERMAL DESIGN AND INTERFACE REQUIREMENTS</u></p> <ul style="list-style-type: none"> · GDTH-050 : updated according to SRS 2.1. · Note on GDTH-090 : added according to MoM H-P-ASPI-MN-642, 27-Nov-2001. · GDTH-110 : empty bullet deleted. · GDHT-150 : requirement identifier corrected into GDTH-150. · GDTH-230 : deleted according to the MoM H-P-ASPI-MN-642, 27-Nov-2001. 	I.Bénilan

GENERAL DESIGN AND INTERFACE REQUIREMENTS (GDIR)

REFERENCE : H-P-1-ASPI-SP-0027

DATE : 25-Nov-2003

ISSUE : 4.2

PAGE : 5/118

Herschel / Planck			CHANGE RECORD	
ISSUE	REV.	DATE	MODIFICATIONS	APPROVAL
3	2	15-Feb-2002	<ul style="list-style-type: none"> · GDTH-240 : deleted and transformed into a recommandation according to the fax H-P-ASPI-LT-953 dated 12-Feb-2002. · GDTH-420 : The last sentence of the requirement is just a recommandation and is therefore put as a simple note after the requirement, according to MoM H-P-ASPI-MN-909 dated 31-Jan, 1st, 4th, 5th & 8th-Feb-2002. <p><u>6. ELECTRICAL DESIGN AND INTERFACE REQUIREMENTS</u></p> <ul style="list-style-type: none"> · GDEL-047 : created according to fax H-P-ASPI-LT-958 dated 13-Feb-2002. · GDEL-048 : created according to fax H-P-ASPI-LT-958 dated 13-Feb-2002. · §6.2.3 : table named and numbered. · GDEL-295 : updated according to the MoM H-P-ASPI-MN-642, 27-Nov-2001. · GDEL-345 : deleted according to MoM H-P-ASPI-MN-909 dated 31-Jan, 1st, 4th, 5th & 8th-Feb-2002. · GDEL-350 : updated in answer to the MoM HP-2-ASED-MN-0036 dated 22-Nov-2001. · Note after GDEL-375 : added according to MoM H-P-ASPI-MN-909 dated 31-Jan, 1st, 4th, 5th & 8th-Feb-2002. · GDEL-410 : deleted according to MoM H-P-ASPI-MN-909 dated 31-Jan, 1st, 4th, 5th & 8th-Feb-2002. · GDEL-415 : modified according to MoM H-P-ASPI-MN-909 dated 31-Jan, 1st, 4th, 5th & 8th-Feb-2002. · GDEL-425 : deleted according to MoM H-P-ASPI-MN-909 dated 31-Jan, 1st, 4th, 5th & 8th-Feb-2002. · GDEL-485 : "if any" deleted in paragraph ii. · GDEL-515 : traceability to SMHA-100 transferred from GDEL-345 to GDEL-515. Minuted in MoM H-P-ASPI-MN-909 dated 31-Jan, 1st, 4th, 5th & 8th-Feb-2002. · GDEL-547 : new requirement as agreed in MoM H-P-ASPI-MN-909 dated 31-Jan, 1st, 4th, 5th & 8th-Feb-2002. · GDEL-560 : deleted in answer to the MoM HP-2-ASED-MN-0036 dated 22-Nov-2001 (the need expressed by this requirement is transferred to GDEL-350). · §6.7.1 : typing errors corrected. · GDEL-575 : updated according to MoM H-P-ASPI-MN-909 dated 31-Jan, 1st, 4th, 5th & 8th-Feb-2002. · GDEL-595 : deleted according to MoM H-P-ASPI-MN-909 dated 31-Jan, 1st, 4th, 5th & 8th-Feb-2002. · GDEL-602 : modified and moved before GDEL-600. · GDEL-600 : modified. 	I.Bénilan

GENERAL DESIGN AND INTERFACE REQUIREMENTS (GDIR)

REFERENCE : H-P-1-ASPI-SP-0027

DATE : 25-Nov-2003

ISSUE : 4.2

PAGE : 6/118

Herschel / Planck			CHANGE RECORD	
ISSUE	REV.	DATE	MODIFICATIONS	APPROVAL
3	2	15-Feb-2002	<ul style="list-style-type: none"> · Table 6-4 : created. · Figure 6-15 : created. · Notes after GDEL-600 : modified. · GDEL-601 : created. · Table 6-5 : created. · Figure 6-16 : created. · GDEL-604 : created, taking into account MoM H-P-ASPI-MN-909 dated 31-Jan, 1st, 4th, 5th & 8th-Feb-2002. · §6.7.4.1 : "electronic fuse" replaced by "HPS" according to MoM H-P-ASPI-MN-909 dated 31-Jan, 1st, 4th, 5th & 8th-Feb-2002. · GDEL-603 : updated according to MoM H-P-ASPI-MN-909 dated 31-Jan, 1st, 4th, 5th & 8th-Feb-2002. · Note before GDEL-610 : deleted. · GDEL-630 : deleted. · GDEL-640 : updated according to the MoM H-P-ASPI-MN-642, 27-Nov-2001. · Figure 6-18 : updated. · GDEL-645 : updated. · GDEL-650 : updated. · GDEL-700 : updated. · §6.7.12 : updated according to fax HP-2-ASED-0017/2 dated 17.01.2002. · Before §6.8.1.2 : figure named and numbered. · §6.8.1 : "Differential Capacitance" and "Voltage Drop" replaced in the tables of the section by "Total Differential Capacitance" and "Total Voltage Drop" according to MoM H-P-ASPI-MN-909 dated 31-Jan, 1st, 4th, 5th & 8th-Feb-2002. · §6.8.2 : "Core to core Capacitance", "Core to shield Capacitance" and "Voltage Drop" replaced in the tables of the section by "Total core to core Capacitance", "Total core to shield Capacitance" and "Total Voltage Drop" according to MoM H-P-ASPI-MN-909 dated 31-Jan, 1st, 4th, 5th & 8th-Feb-2002. · GDEL-750: characteristics of the table updated according to fax H-P-ASPI-LT-445, 10-Oct-2001. <p>APPENDIX 1 : created (but still TBD). APPENDIX 2 : formerly known as APPENDIX 1 ; updated. IDS comments of ANNEX #5 of the MoM H-P-ASPI-MN-909 dated 31-Jan, 1st, 4th, 5th & 8th-Feb-2002 have been taken into account.</p>	I.Bénilan

GENERAL DESIGN AND INTERFACE REQUIREMENTS (GDIR)

REFERENCE : H-P-1-ASPI-SP-0027

DATE : 25-Nov-2003

ISSUE : 4.2

PAGE : 7/118

Issue	Date	Modification	Author
4.0	14-Mar-2003	<p>Post PDR update (DOORS 5.2/TREK 3-to-Word generated) including :</p> <ul style="list-style-type: none"> - latest SRS updates 3.0 and 3.1 - removal of TBC and TBD - closure of PDR RIDs - introduction of agreements for refinement/clarification of requirements <p><u>General :</u> ASPI modified in ASP (except in the document reference H-P-1-ASPI-SP-0027) A reference is given to each Table and Figure, in particular in §6.8. Requirements deleted in the previous issues are no more displayed.</p> <p><u>Rectification of paragraph numbering :</u> AD-1 to AD-10 grouped under new paragraph §2.1.1. § "Applicable Standard Documents" and its children are therefore renumbered from 2.1.1 to 2.1.2. §3.1.1 renumbered in §3.1 and so on §6.2.3.1.1 renumbered in §6.2.3.1 and so on §6.7.4.1 renumbered in §6.7.5 §6.7.5 renumbered in §6.7.6 and so on</p> <p><u>Modifications out of the requirements</u></p> <p>AD-6 (Radiation requirements) : reference corrected. AD-7 (SRS) : deleted. RD-8 (SRS) : added.</p> <p>§6.6.1 : Note after GDEL-375 : deleted. §6.7.13 : NED (Non Explosive Device) replaced by NCA (Non Contamination Actuator) §6.8.2.2 : thermistor characteristics updated.</p> <p>Appendix 1 : renamed. Appendix 2 : deleted (its content has been incorporated in Appendix 1). Mechanical IDS / Dimensions : addition of "including mounting feet". Mechanical IDS / Inertia matrix : "-lxy", "-lxz" and "-lyz" corrected in "lxy", "lxz" and "lyz".</p> <p><u>Modifications in the requirements</u> through the change requests H-P-ASP-CR-0358 (CSAG), -0359 (ALS), -0360 (ASED), -0361 (CSL), -0362 (PROTOTEC) : See the Changes History below.</p>	I.Bénilan

GENERAL DESIGN AND INTERFACE REQUIREMENTS (GDIR)

REFERENCE : H-P-1-ASPI-SP-0027

DATE : 25-Nov-2003

ISSUE : 4.2

PAGE : 8/118

§ nb	Req. identifier	Change Status	Doc. issue	Reason of Change	CCB Ref.
§3.2	[GDGE-030 a]	Modified in	4.0	Addition of the note.	
§3.2	[GDME-035]	New in	4.0	Replacement of GDEL-460. Microsoft Access database is not used. TBC are removed.	
§3.3	[GDGE-040 a]	Deleted in	4.0	Superseded by §6.2.9 of H-P-1-ASPI-SP-0018 (PA requirements for Subcontractors)	
§3.3	[GDGE-180 a]	Modified in	4.0	RFW deleted.	
§3.6	[GDGE-240 a]	Modified in	4.0	SRS 3.1	
§3.8	[GDGE-430 a]	Modified in	4.0	Split from GDGE-430 v1 (SRS 3.0)	
§3.8	[GDGE-432]	New in	4.0	Split from GDGE-430 v1 (SRS 3.0)	
§3.9	[GDGE-520 a]	Modified in	4.0	Addition of "according to requirements of AD-3".	
§3.9	[GDGE-530 a]	Modified in	4.0	Addition of "according to requirements of AD-3".	
§3.14.3.3	[ENVR-160 a]	Modified in	4.0	SRS 3.1	
§4.4.1	[GDME-050 a]	Modified in	4.0	SRS 3.1	
§4.6.3	[GDME-190 a]	Modified in	4.0	A reference is given to the table.	
§4.6.4	[GDME-240 a]	Modified in	4.0	Minor rephrasing for unambiguous understanding. Creation of acronyms YSF, USF and BSF. Addition of SF for sliding. Addition of possible relaxation for standard inserts (SRS 3.1).	
§4.6.5	[GDME-260 a]	Modified in	4.0	A reference to the equation is given.	
§4.6.6	[GDME-280 a]	Modified in	4.0	TBC removed. Applicability redefined. Phrasing updated.	
§4.8.2	[GDME-330 a]	Modified in	4.0	Figure 4-7 moved from after GDME-430 to inside GDME-330.	
§4.8.2	[GDME-350 a]	Modified in	4.0	Reference to §4.3-2 corrected by a reference to Figure 4-5.	
§4.8.2	[GDME-360 a]	Modified in	4.0	Equations are updated and referenced. Incorrect reference to §4.7.4 is deleted.	
§4.8.4	[GDME-440 a]	Modified in	4.0	Reworded with the mass per attachment point limit.	
§4.8.4	[GDME-445]	New in	4.0	New requirement. Table 4-6 created.	
§4.8.4	[GDME-450 a]	Modified in	4.0	TBD removed.	
§4.8.4	[GDME-460 a]	Modified in	4.0	Figures 4-9 and 4-11 moved from after GDME-485 to within GDME-460.	
§5.1.2	[GDTH-040 a]	Modified in	4.0	Split from GDTH-040 v1	
§5.1.2	[GDTH-042]	New in	4.0	Split from GDTH-040 v1	

GENERAL DESIGN AND INTERFACE REQUIREMENTS (GDIR)

REFERENCE : H-P-1-ASPI-SP-0027

DATE : 25-Nov-2003

ISSUE : 4.2

PAGE : 9/118

§ nb	Req. identifier	Change Status	Doc. issue	Reason of Change	CCB Ref.
§5.2.1	[GDTH-100 a]	Modified in	4.0	Split from GDTH-100 v1	
§5.2.1	[GDTH-101]	New in	4.0	Split from GDTH-100 v1	
§5.2.1	[GDTH-102]	New in	4.0	Split from GDTH-100 v1	
§5.2.1	[GDTH-103]	New in	4.0	Split from GDTH-100 v1	
§5.2.1	[GDTH-104]	New in	4.0	Split from GDTH-100 v1	
§5.2.1	[GDTH-106]	New in	4.0	Split from GDTH-100 v1	
§5.2.1	[GDTH-107]	New in	4.0	Split from GDTH-100 v1	
§5.2.1	[GDTH-108]	New in	4.0	Split from GDTH-100 v1	
§6.2.2.1.1	[GDEL-048 a]	Modified in	4.0	TBC removed. Second "Non-metallic structural elements" replaced by "grounding rails" (typing error corrected).	
§6.2.3.3	[GDEL-280 a]	Modified in	4.0	Introduction phrase preceding the requirement incorporated in the requirement. Figure 6.2.3-1 renumbered in Figure 6-10.	
§6.6.2.3	[GDEL-440 a]	Modified in	4.0	Figure 6-11 moved from after GDEL-450 directly into GDEL-440. Note on this figure added and incorporated in the requirement.	
§6.6.2.4	[GDEL-460 a]	Deleted in	4.0	Replaced by GDGE-035.	
§6.7.3	[GDEL-590 a]	Modified in	4.0	Figure 6-13 updated (Closure of System PDR RID 8457 by H-P-ASPI-LT-2335)	
§6.7.4	[GDEL-600 a]	Modified in	4.0	Reference to Table 4-1 corrected by reference to Table 6-4	
§6.7.8	[GDEL-615 a]	Modified in	4.0	I_l replaced by I_{limit} , as defined in GDEL-600.	
§6.7.12	[GDEL-710 a]	Modified in	4.0	TBC removed.	
§6.8.1.4	[GDEL-711]	Modified in	4.0	Req. identifier "GDEL-730" already used in §6.8.3 and therefore replaced by "GDEL-711". Requirement content unchanged.	
§6.8.3	[GDEL-740 a]	Modified in	4.0	Typing error "1153" corrected in "1553".	
§6.8.4	[GDEL-745]	Modified in	4.0	Req. identifier "GDEL-740" already used in §6.8.3 and therefore modified in "GDEL-745". Requirement content unchanged.	
§6.8.4	[GDEL-750 a]	Modified in	4.0	TBC and TBD removed. A reference is given to the table.	

GENERAL DESIGN AND INTERFACE REQUIREMENTS (GDIR)

REFERENCE : H-P-1-ASPI-SP-0027

DATE : 25-Nov-2003

ISSUE : 4.2

PAGE : 10/118

Issue	Date	Change Record	Author
4.1	05-Jun-2003	<p>Release of the complete document generated by DOORS 5.2 / TREK 3.</p> <p>In this issue, the change bars show the paragraphs new or modified since issue 4.0. Requirements deleted in issue 4.0 or before are not displayed.</p> <p>§1 : renamed and enriched with the new sub-paragraph §1.2.</p> <p>§6.8.2.3 : modified according to the Change Requests H-P-ASP-CR-0400 (to ALS) and H-P-ASP-CR-0401 (to ASED). Reason of change = Harmonisation of procurement of Platinum sensors acquired by the SVM (fax H-P-ASP-LT-3017 dated 17-Apr-2003).</p>	I.Bénilan
<u>4.2</u>	<u>25-Nov-2003</u>	<p><u>Release of the complete document generated by DOORS 5.2 / TREK 3 following mid phase C "SVM AD Convergence Meeting - GDIR", ref. H-P-ASP-MN-3609 dated 10-Sep-2003.</u></p> <p><u>In this issue, the change bars show the paragraphs new or modified since issue 4.1. Requirements deleted in issue 4.1 or before are not displayed.</u></p> <p><u>RD-10: new.</u></p> <p><u>§6.7.13 NCA: updated after teleconference with ASED hold 27-Jun-2003 (Austrian Aerospace material), after HP-2-AAE-RD-0001 and according to ASP internal discussion.</u></p> <p><u>§6.8.1.5 ML16, Table 6-19: typo error corrected (insertion of symbol ≈).</u></p> <p><u>§6.8.2.2 Thermistor acquisition: updated according to H-P-ASP-MN-3609.</u></p> <p><u>§6.8.2.3 Cryo-temperature and SA temperature acquisition: updated in order to close AI#3 of H-P-ASP-MN-3609. Reason of change is H-P-EC-AI-0075 dated 29-Oct-2003 (modification of CDMU-ACC IF).</u></p> <p><u>§6.8.2.4, Table 6-27 Digital relay status acquisition interface characteristics: updated according to H-P-ASP-MN-3609.</u></p> <p><u>Requirements modified, new or deleted in issue 4.2: see list below.</u></p>	<u>I.Bénilan</u>

GENERAL DESIGN AND INTERFACE REQUIREMENTS (GDIR)

REFERENCE : H-P-1-ASPI-SP-0027

DATE : 25-Nov-2003

ISSUE : 4.2

PAGE : 11/118

Requirements modified, new or deleted in issue 4.2

§ nb	Req. identifier	Change Status	Doc. issue	Reason of Change	Change Ref.
§3.2	[GDGE-035 a]	<u>Modified in</u>	<u>4.2</u>	<u>H-P-ASP-MN-3609: Requirement identifier GDME-035 renamed in GDGE-035.</u>	<u>H-P-ASP-CR-0526 (ALS)</u>
§3.12	[GDGE-590 a]	<u>Modified in</u>	<u>4.2</u>	<u>H-P-ASP-MN-3609.</u>	<u>H-P-ASP-CR-0526 (ALS)</u>
§4.6.6	[GDME-280 b]	Modified in	<u>4.2</u>	<u>H-P-ASP-MN-3609.</u>	<u>H-P-ASP-CR-0526 (ALS)</u>
§4.8.2	[GDME-360 b]	Modified in	<u>4.2</u>	<u>H-P-ASP-MN-3609.</u>	<u>H-P-ASP-CR-0526 (ALS)</u>
§4.8.4	[GDME-450 b]	<u>Deleted in</u>	<u>4.2</u>	<u>H-P-ASP-MN-3609.</u>	<u>H-P-ASP-CR-0526 (ALS)</u>
§4.8.4	[GDME-460 b]	<u>Deleted in</u>	<u>4.2</u>	<u>H-P-ASP-MN-3609.</u>	<u>H-P-ASP-CR-0526 (ALS)</u>
§4.8.4	[GDME-480 a]	<u>Modified in</u>	<u>4.2</u>	<u>Closure of AI#1 of H-P-ASP-MN-3609: Titles of Tables 4-11 and 4-13 updated and Tables 4-11 and 4-13 updated according to email "GDME-480 update" from Ph.Clavel dated 28-Nov-2003.</u>	<u>H-P-ASP-CR-0526 (ALS)</u>
§5.1.2	[GDTH-040 b]	Modified in	<u>4.2</u>	<u>H-P-ASP-MN-3609.</u>	<u>H-P-ASP-CR-0526 (ALS)</u>
§5.1.2	[GDTH-042 a]	<u>Modified in</u>	<u>4.2</u>	<u>H-P-ASP-MN-3609.</u>	<u>H-P-ASP-CR-0526 (ALS)</u>
§5.2.2	[GDTH-260 a]	<u>Modified in</u>	<u>4.2</u>	<u>H-P-ASP-MN-3609.</u>	<u>H-P-ASP-CR-0526 (ALS)</u>
§5.3.2	[GDTH-390 a]	<u>Deleted in</u>	<u>4.2</u>	<u>H-P-ASP-MN-3609.</u>	<u>H-P-ASP-CR-0526 (ALS)</u>
§6.2.2.2	[GDEL-115 a]	<u>Modified in</u>	<u>4.2</u>	<u>Clarification according to H-P-ASP-MN-3609.</u>	<u>H-P-ASP-CR-0526 (ALS)</u>
§6.2.2.2	[GDEL-165 a]	<u>Modified in</u>	<u>4.2</u>	<u>Update according to a mix of H-P-ASP-MN-3609 and email of P.Rideau dated 26-Nov-2003.</u>	<u>H-P-ASP-CR-0526 (ALS)</u>
§6.2.3.3	[GDEL-280 b]	Modified in	<u>4.2</u>	<u>Closure of AI#2 of H-P-ASP-MN-3609.</u>	<u>H-P-ASP-CR-0526 (ALS)</u>
§6.7.4	[GDEL-604 a]	<u>Modified in</u>	<u>4.2</u>	<u>H-P-ASP-MN-3609: 3rd bullet removed (HCS drop < 1 V), as confusing and covered by GDEL-603.</u>	<u>H-P-ASP-CR-0526 (ALS)</u>

GENERAL DESIGN AND INTERFACE REQUIREMENTS (GDIR)

REFERENCE : H-P-1-ASPI-SP-0027

DATE : 25-Nov-2003

ISSUE : 4.2

PAGE : 12/118

TABLE OF CONTENTS

DISTRIBUTION / DISTRIBUTION RECORD	2
ENREGISTREMENT DES EVOLUTIONS / CHANGE RECORD	3
TABLE OF CONTENTS	12
LIST OF FIGURES AND TABLES	16
1. INTRODUCTION	18
1.1 SCOPE	18
1.2 REQUIREMENT NUMBERING SYSTEM	18
2. DOCUMENTS	19
2.1 APPLICABLE DOCUMENTS	19
2.1.1 <i>Applicable Herschel/Planck specific documents</i>	19
2.1.2 <i>Applicable Standard Documents</i>	19
2.1.2.1 Ariane Standards	19
2.1.2.2 ESA standards.....	20
2.1.2.3 ECSS Standards	20
2.1.2.4 Other Standards	21
2.2 REFERENCE DOCUMENTS.....	21
3. GENERAL DESIGN AND INTERFACE REQUIREMENTS	22
3.1 ENGINEERING STANDARD UNITS	22
3.2 INTERFACE CONTROL	22
3.3 PARTS, MATERIAL AND PROCESSES	22
3.4 HARDWARE PRODUCTION REQUIREMENTS.....	25
3.5 INTERCHANGEABILITY	25
3.6 LIFETIME	25
3.7 MAINTAINABILITY, ACCESSIBILITY, REPARABILITY AND TESTABILITY.....	26
3.8 RELIABILITY, FAULT TOLERANCE AND SINGLE POINT FAILURES	27
3.9 SAFETY	29
3.10 WORKMANSHIP	30
3.11 IDENTIFICATION AND PRODUCT MARKING	30
3.12 CLEANLINESS	31
3.13 HANDLING, PACKING AND TRANSPORTATION	31
3.14 RADIATIONS.....	32
3.14.1 <i>Radiation Dose</i>	32
3.14.2 <i>Radiation induced background</i>	33
3.14.3 <i>Single Event Effects</i>	33
3.14.3.1 Single event latch-up	33
3.14.3.2 Single event burn-out and single event gate rupture	34
3.14.3.3 Single event upset (SEU)	34
3.15 ELECTROSTATIC CHARGING	35
3.16 DEBRIS.....	35
4. MECHANICAL DESIGN AND INTERFACE REQUIREMENTS	36
4.1 MECHANICAL REFERENCE FRAMES.....	36

GENERAL DESIGN AND INTERFACE REQUIREMENTS (GDIR)

REFERENCE : H-P-1-ASPI-SP-0027

DATE : 25-Nov-2003

ISSUE : 4.2

PAGE : 13/118

4.1.1	Satellite Axes Definition	36
4.1.1.1	Herschel	36
4.1.1.2	PLANCK.....	37
4.1.2	Unit reference frame	37
4.2	GENERAL REQUIREMENTS	38
4.3	HANDLING PROVISIONS	39
4.4	UNITS PHYSICAL CHARACTERISTICS	39
4.4.1	Mass	39
4.4.2	Centre of mass	40
4.4.3	Moments of inertia.....	41
4.4.4	Size	41
4.5	UNIT LAYOUT AND INTERFACES	41
4.6	STRUCTURAL DESIGN	42
4.6.1	Definitions	42
4.6.2	Stiffness requirements	42
4.6.3	Strength requirements	42
4.6.4	Safety factors.....	44
4.6.5	Loads and margins of safety.....	44
4.6.6	Preliminary design loads	45
4.7	ALIGNMENT	46
4.7.1	Alignement provisions	46
4.7.2	Alignment with mirror.....	46
4.8	UNIT FIXATION.....	47
4.8.1	Functional requirements	47
4.8.2	Lug general design characteristics (boxes)	47
4.8.3	Lug interface.....	50
4.8.4	Fixation hardware.....	50
4.8.5	Baseplate/Surface finish.....	53
4.8.5.1	General.....	53
4.8.5.2	Surface finish treatment	54
4.8.6	Electrical bonding	54
4.8.7	Grounding.....	54
4.8.8	Damping supports.....	54
4.9	VERIFICATION OF THE MECHANICAL DESIGN.....	55
4.9.1	Modelling.....	55
4.9.2	Analyses.....	56
4.9.3	Testing	57
5.	THERMAL DESIGN AND INTERFACE REQUIREMENTS	58
5.1	GENERAL	58
5.1.1	General requirements	58
5.1.2	Equipment Temperature limits.....	58
5.1.3	Temperature reference points	61
5.2	SATELLITE THERMAL DESIGN	61
5.2.1	General.....	61
5.2.2	Material and components	64
5.3	EQUIPMENT THERMAL DESIGN	65
5.3.1	General requirements	65

GENERAL DESIGN AND INTERFACE REQUIREMENTS (GDIR)

REFERENCE : H-P-1-ASPI-SP-0027

DATE : 25-Nov-2003

ISSUE : 4.2

PAGE : 14/118

5.3.2	Design requirements	65
5.4	VERIFICATION OF THERMAL DESIGN	67
5.4.1	Modelling	67
5.4.2	Analysis	68
5.4.3	Testing	68
6.	ELECTRICAL DESIGN AND INTERFACE REQUIREMENTS	69
6.1	GENERAL	69
6.2	GROUNDING BONDING AND ISOLATION	69
6.2.1	General	69
6.2.2	Structural grounding and bonding	72
6.2.2.1	Bonding	72
6.2.2.2	Thermal control parts	77
6.2.2.3	Exposed conductors	79
6.2.2.4	Conductive element grounding	79
6.2.2.5	External electronic component	80
6.2.3	Circuit grounding	80
6.2.3.1	Power bus grounding	80
6.2.3.2	Secondary power grounding	81
6.2.3.3	Signal return grounding	82
6.3	CHARGING/ELECTROSTATIC DISCHARGE PROTECTION	82
6.4	ELECTROMAGNETIC INTERFACE REQUIREMENTS	82
6.5	MAGNETIC CLEANLINESS	82
6.6	WIRING AND CONNECTIONS	83
6.6.1	General	83
6.6.2	Connectors	86
6.6.2.1	Connector types	86
6.6.2.2	Characteristics	87
6.6.2.3	Connector mounting and identification	87
6.6.2.4	Connector pin assignment and interface circuit data	89
6.6.2.5	Connector savers	90
6.6.3	Shielding, redundancy and identification	90
6.6.3.1	Twisted and shielded lines / Overshielding	90
6.6.3.2	Wiring Redundancy	92
6.6.4	Wiring rules	92
6.6.4.1	Crimping of wires	92
6.6.4.2	Soldering of wires	92
6.6.4.3	Current derating of wires	93
6.7	ELECTRICAL POWER SYSTEM INTERFACE	93
6.7.1	Power supply voltages	93
6.7.2	Voltage transients and ripple	94
6.7.3	Bus output impedance	94
6.7.4	Current limiter characteristics	95
6.7.5	Heaters line	98
6.7.6	Average power demand definition	98
6.7.7	Peak power demand definition	98
6.7.8	Distribution and Protection Requirements	99
6.7.9	Load current transitions	99
6.7.9.1	In-rush current	99
6.7.9.2	Load current transitions	100
6.7.10	Insulation of the power lines	100
6.7.11	Isolation	101

GENERAL DESIGN AND INTERFACE REQUIREMENTS (GDIR)

REFERENCE : H-P-1-ASPI-SP-0027

DATE : 25-Nov-2003

ISSUE : 4.2 PAGE : 15/118

6.7.12	DC/DC converter synchronisation	101
6.7.13	NCA	101
6.8	DATA HANDLING INTERFACES	102
6.8.1	Commands Interfaces	102
6.8.1.1	High Priority (HP) or High Level Commands (HL).....	102
6.8.1.2	Extended High Level Commands (EHL)	105
6.8.1.3	Low level command	105
6.8.1.4	The Standard Balanced Digital Link (SBDL)	105
6.8.1.5	Memory Load Command (ML16)	108
6.8.2	Telemetry Interfaces	110
6.8.2.1	Analogue telemetry	110
6.8.2.2	Thermistor acquisition	111
6.8.2.3	Cryo-temperature and Solar Array temperature acquisition	112
6.8.2.4	Digital relay status acquisition	113
6.8.2.5	Digital bi-level acquisition	114
6.8.2.6	Status Lines	115
6.8.2.7	Digital Serial Acquisition (DS16).....	115
6.8.3	MIL-STD-1553B bus	116
6.8.4	Timing and synchronisation	117
APPENDIX 1 : ICD TEMPLATE		118

LIST OF FIGURES AND TABLES

Figure 4-1: Herschel Spacecraft Axes	36
Figure 4-3: PLANCK Spacecraft Axis.....	37
Figure 4-5: Unit Reference Frame.....	38
Table 4-0 : Mass for structural strength dimensioning	43
Table 4-1 : Basic Safety Factors.....	44
Equation 4-1 : MOS.....	45
Table 4-3: Preliminary design loads	46
Figure 4-7: Unit Lug Interface Design	48
Equation 4-2 : No sliding criteria (using USF for sliding)	49
Equation 4-3 : Design loads at attachment points criteria (using USF for joints)	49
Table 4-5: Friction coefficient values.....	49
Table 4-6 : Screw capability	51
Table 4-11: Thread characteristics for single inserts at external interfaces (intended for unit inserts)	51
Table 4-13: Thread characteristics for special inserts (e.g. face-to-face inserts) at external interfaces (intended for internal structural inserts)	52
Table 4-15: inserts positional tolerances.....	52
Figure 5-1: Temperature limits definition	60
Figure 6-1: Symbols for Grounding Diagrams	71
Figure 6-3: Dissimilar metals EMF compatibility table.	74
Figure 6-5: Typical Bonding Methods	75
Figure 6-7: Bonding of Thermal Blankets (Guideline).....	78
Table 6-1: Bonding resistance insulation values.....	80
Figure 6-9: Secondary power output grounding rules.....	81
Figure 6-11: Location of Connectors	88
Table 6-2: Wires Current Derating Criteria	93
Figure 6-13: Bus Impedance at S/C Harness-User Subsystem Interface	95
Table 6-4 : Definition of the LCL classes and corresponding I_{class} , $I_{limit\ min}$ and $I_{limit\ max}$	96
Figure 6-15 : LCL characteristics	96
Table 6-5 : FCL characteristics	97
Figure 6-16 : FCL current-voltage characteristics	97
Figure 6-18 : Nominal current envelope.....	100
Figure 6-24 : Electrical scheme of a command line driving a relay.....	102
Figure 6-26 : Electrical scheme of a command line driving an opto-coupler	102

GENERAL DESIGN AND INTERFACE REQUIREMENTS (GDIR)

REFERENCE : H-P-1-ASPI-SP-0027

DATE : 25-Nov-2003

ISSUE : 4.2 PAGE : 17/118

Table 6-7 : HP or HL commands interface characteristics for relay	103
Table 6-9 : HP or HL commands interface characteristics for opto-coupler	104
Figure 6-19 : Signal waveform for the HLC pulses	105
Table 6-11 : EHL commands interface characteristics	105
Figure 6-20 : Schematic Electrical interface for the SBDL.....	106
Figure 6-22 : SBDL Interface Details	106
Table 6-13 : SBDL driver characteristics.....	107
Table 6-15 : SBDL line characteristics	107
Table 6-17 : SBDL receiver characteristics.....	108
Figure 6-28 : ML16 command timing (B0 is MSB).....	109
Table 6-19 : ML16 command timing requirement.....	109
Table 6-21 : Analogue telemetry interface characteristics	110
Table 6-23 : Thermistor acquisition interface characteristics	111
Table 6-25 : Cryo-temperature acquisition interface characteristics	112
Figure 6-30 : Electrical scheme of a digital relay status acquisition line	113
Table 6-27 : Digital relay status acquisition interface characteristics	113
Figure 6-32 : Electrical scheme of a digital bi-level acquisition line	114
Table 6-29 : Digital bi-level acquisition interface characteristics	115
Figure 6-34 : DS16 acquisition timing (B0 is MSB)	116
Table 6-31 : DS16 acquisition timing requirements	116
Table 6-33 : Synchronisation signal characteristics	117

1. INTRODUCTION

1.1 Scope

This specification establishes the general design and interface requirements that are to be met by the satellite units to ensure the correct hardware performances during assembly, integration, testing, launch and orbital operations.

Additional design and interface requirements specific to a subsystem are given in the relevant subsystem specification.

1.2 Requirement numbering system

In this document, each requirement is unambiguously identified by a requirement identifier that has the following structure :

XXXX-nnn

where

- XXXX is one of the following quadrigrammes :
 - GDGE for general design and interface requirements (§3.1 till §3.13)
 - ENVR for general design and interface requirements related to environment (§3.14 till §3.16)
 - GDME for mechanical design and interface requirements (§4)
 - GDTH for thermal design and interface requirements (§5)
 - GDEL for electrical design and interface requirements (§6)
- nnn is the sequential number.

In addition, for traceability purpose, parent requirements are indicated as following :

[P:<Parent_Specification_Reference>#<Parent_Paragraph_Number>-<Parent_Requirement_Identifier>

Example : [P:SCI-PT-RS-05991 - Ch.4#4.2.7-MISS-130 H

This example indicates that the requirement "MISS-130 H" in §4.2.7 of the specification SCI-PT-RS-05991 - Chapter 4 (SRS) is a parent of the current requirement.

2. DOCUMENTS

2.1 Applicable documents

2.1.1 Applicable Herschel/Planck specific documents

- AD- 1 Environment and Tests Requirements
H-P-1-ASPI-SP-0030
- AD- 2 PA Requirements for subcontractors
H-P-1-ASPI-SP-0028
- AD- 3 Safety Requirements for subcontractors
H-P-1-ASPI-SP-0029
- AD- 4 Herschel/Planck EMC Specification
H-P-1-ASPI-SP-0037
- AD- 5 Cleanliness Requirements Specification
H-P-1-ASPI-SP-0035
- AD- 6 Radiation Requirements
H-P-1-ASPI-SP-0017
- AD- 7 Deleted
- AD- 8 Mechanical Mathematical Model Specification
H-P-1-ASPI-SP-0014
- AD- 9 Requirements for the delivery of thermal mathematical models
TBD
- AD- 10 Deleted

2.1.2 Applicable Standard Documents

2.1.2.1 Ariane Standards

- AD- 11 ARIANE 5 User's Manual
Issue 3 / Rev 0 Mar 2000
- AD- 12 CSG Safety Regulations
Volume 1 - General rules CSG-RS-10A-CN
Issue/Rev/Date 5/1/ 03.03.99 (Volume 1 taken precedence)
- AD- 13 CSG safety regulations
CSG-RS-22A-CN issue 5/0 (Vol. 1) and
CSG-RS-22A (Vol. 2) Edition 4, August 1991
- AD- 14 CSG Volume 2 Part 1. Ground Installations
GSG-RS-21A-CN Issue 5 / Rev 0 Dec 1997
- AD- 15 Ariane General Specification for Payload Dynamic Model
A5-SG-0-01, Issue 4

GENERAL DESIGN AND INTERFACE REQUIREMENTS (GDIR)

REFERENCE : H-P-1-ASPI-SP-0027

DATE : 25-Nov-2003

ISSUE : 4.2

PAGE : 20/118

2.1.2.2 ESA standards

- AD- 16 Telemetry Channel Coding Standard
ESA PSS-04-103, Issue 1, Sept 1989
- AD- 17 Ranging Standard
ESA PSS-04-104 Issue 2, March 1991
- AD- 18 Radio Frequency and Modulation Standard
ESA-PSS-04-105 Issue 2.4, Nov 1996
- AD- 19 Packet Telemetry Standard
ESA-PSS-04-106, Issue 1, Jan 1988
- AD- 20 Packet Telecommand Standard
ESA-PSS-04-107, Issue 2, Apr 1992
- AD- 21 Generic Specification for Silicon Solar Cells
ESA PSS-01-604, Jan. 1998
- AD- 22 Generic Specification for Gallium Arsenide Solar Cells
SPA-TS-0006, July 1997
- AD- 23 ESA Power Subsystem Standard Specification
ESA-PSS-02-10, Nov 1992
- AD- 24 Data for Selection of Space Materials
ESA-PSS-01-701, current issue

2.1.2.3 ECSS Standards

- AD- 25 Space Mechanisms Standard Requirements Specification
ECSS-E-30-00 Part 2-3
- AD- 26 ESA Fracture Control requirements
ECSS-E30-01A
- AD- 27 A Thermal Vacuum Test for the Screening of Space Materials
ECSS-Q-70-02, Draft
- AD- 28 A Thermal Cycling Test for the Screening of Space Materials and Processes
ECSS-Q-70-04
- AD- 29 Material Selection for Controlling Stress Corrosion Cracking
ECSS-Q-70-36A
- AD- 30 Determination of Susceptibility of Metals to Stress Corrosion Cracking
ECSS-Q-70-37
- AD- 31 ESA Software Engineering Standards
ESA-ECSS-E-40
- AD- 32 Time Code Format
CCSDS 301.0-B-2, issue 2
- AD- 33 Software Product Assurance
ESA-ECSS-Q-80
- AD- 34 Lossless data compression
CCSDS 121.0-B-1, May 1997
- AD- 35 Space Engineering Standards – Mechanical - Thermal Control
ECSS-E-30-PART1A

GENERAL DESIGN AND INTERFACE REQUIREMENTS (GDIR)

REFERENCE : H-P-1-ASPI-SP-0027

DATE : 25-Nov-2003

ISSUE : 4.2

PAGE : 21/118

2.1.2.4 Other Standards

AD- 36 MIL-HDBK-5

AD- 37 ESA Preferred Parts List
ECSS-Q-60-01

AD- 38 Crimping or High Reliability Electrical Connections
ESA PSS-01-726 Issue 2

AD- 39 The manual soldering of High Reliability Electrical Connections
ESA PSS-01-708 Issue 1

AD- 40 Derating requirements applicable to electronic, electrical and electro-mechanical components for ESA space systems
ESA PSS-01-301 Issue 2

AD- 41 Packet Structure – Interface Control Document
SCI-PT-ICD-7527

2.2 Reference documents

RD- 1 ESA Pointing Error Handbook
ESA-NCR-502, Issue 1, Feb 1993

RD- 2 Radiation Design Handbook
ESA-PSS-01-609, Issue 1, May 1993

RD- 3 Packet Utilisation Standard (PUS)
ECSS-E-70/41 Draft

RD- 4 Guide to Applying the ESA Software Engineering Standards to Small Project
BSSC (96)2, Issue 1, May 1996

RD- 5 Telecommand Decoder Specification
ESA-PSS-04-151

RD- 6 Straylight Evaluation for Planck
PT-05985, 23 June 1989

RD- 7 CCSDS Telemetry Channel Coding
CCSDS 101.0-B-4

RD- 8 ESA System Requirements Specification
SCI-PT-RS-05991

RD- 9 Herschel/Planck Product Tree
H-P-1-ASPI-TE-0012

RD- 10 Herschel/Planck SVM EvTR
H-P-SP-AI-0033

GENERAL DESIGN AND INTERFACE REQUIREMENTS (GDIR)

REFERENCE : H-P-1-ASPI-SP-0027

DATE : 25-Nov-2003

ISSUE : 4.2

PAGE : 22/118

3. GENERAL DESIGN AND INTERFACE REQUIREMENTS

3.1 Engineering standard units

Reference **GDGE-010**

[P:SCI-PT-RS-05991 - Ch.5#5.1.1-SGEN-010 H/P

All drawings, specifications and engineering data shall only use the International System of Units (SI units). (SGEN-010)

*

3.2 Interface control

Reference **GDGE-020**

Each unit and subsystem shall be designed so as to ensure compatibility and proper interaction with other equipment and subsystems under all specified environmental conditions.

*

Reference **GDGE-030 a**

Each unit interface shall be controlled by Interface Control Documents (ICD) providing mechanical properties as well as electrical, telemetry, telecommand and thermal data. The ICD table of contents and the standard Interface Data Sheets (IDS) to be used within the ICD for interfaces description, are provided in Appendix 1.

Note : In order to ease the ICD/IDS generation, Alcatel Space electronically distributes the ICD template as a separated .dot file. Instructions on the use of this .dot file are provided on the first page of Appendix 1. The use of this ICD template is fostered, but not mandatory.

*

Reference **GDGE-035 a**

The ICD/IDS shall be transmitted to the Prime on both of the following electronic formats :

- native Microsoft Word 97 electronic format (.doc).
- Adobe Portable Document File 4 electronic format (.pdf) with 1st signed page scanned.

*

3.3 Parts, Material and Processes

Reference **GDGE-050**

[P:SCI-PT-RS-05991 - Ch.5#5.1.5-SGEN-080 H/P

The parts, materials and processes shall comply with the requirements, the environments and the quality assurance provisions as specified herein and with AD- 24. (SGEN-080)

*

GENERAL DESIGN AND INTERFACE REQUIREMENTS (GDIR)

REFERENCE : H-P-1-ASPI-SP-0027

DATE : 25-Nov-2003

ISSUE : 4.2

PAGE : 23/118

Reference **GDGE-060**

[P:SCI-PT-RS-05991 - Ch.5#5.1.5-SGEN-085 H/P

The selection of mechanical parts shall be justified by analyses, similarity, and if necessary, appropriate tests and their qualification for the required application shall be demonstrated. (SGEN-085)

*

Reference **GDGE-070**

[P:SCI-PT-RS-05991 - Ch.5#5.1.5-SGEN-090 H/P

Materials which are not used inside pressurised volumes on the spacecraft shall have low outgassing properties with in general Total Mass Loss (TML) < 1% and Collected Volatile Condensable Material (CVCM) < 0.1% as determined by test method according to AD- 27. In case of materials used in the vicinity of critical (optical) elements, the more stringent requirement of Recovered Mass Loss (RML) < 0.1% and CVCM < 0.01% shall apply. It should be noted that outgassing characteristics are determined after a vacuum baking at 125°C for 24 hours. (SGEN-090)

*

Reference **GDGE-080**

[P:SCI-PT-RS-05991 - Ch.5#5.1.5-SGEN-095 H/P

Materials shall not be flaking or dusting so that a high degree of cleanliness of the flight hardware can be achieved and maintained. This is also applicable to materials used on GSE. (SGEN-095)

*

Reference **GDGE-090**

[P:SCI-PT-RS-05991 - Ch.5#5.1.5-SGEN-100 H/P

Materials and combinations of materials bonded to each other shall be resistant to the thermal cycling to which they will be exposed until the end of the mission. A standard thermal cycling method is defined in AD-28 but the contractor shall as necessary perform specific thermal cycling tests which are representative of the actual qualification temperatures for the application, for qualification with at least a factor of 1.5 on the number of cycles expected until end of the nominal lifetime (minimum 10 cycles). (SGEN-100)

*

Reference **GDGE-100**

[P:SCI-PT-RS-05991 - Ch.5#5.1.5-SGEN-105 H/P

Materials shall be resistant to the radiation to which they will be exposed during their operational lifetime. The contractor shall determine what the anticipated radiation environment will be for materials used in various locations and as necessary demonstrate by appropriate testing that the properties shall not degrade below acceptable limits for significant properties. (SGEN-105)

*

Reference **GDGE-110**

[P:SCI-PT-RS-05991 - Ch.5#5.1.5-SGEN-110 H/P

Materials which are in contact with each other shall be compatible with each other. Compatibility shall be demonstrated by test if insufficient data are available from standard references or previous applications. (SGEN-110)

GENERAL DESIGN AND INTERFACE REQUIREMENTS (GDIR)

REFERENCE : H-P-1-ASPI-SP-0027

DATE : 25-Nov-2003

ISSUE : 4.2

PAGE : 24/118

*

Reference **GDGE-120**

[P:SCI-PT-RS-05991 - Ch.5#5.1.5-SGEN-115 H/P

Materials shall be resistant to corrosion or they shall be suitably protected against corrosion. (SGEN-115)

*

Reference **GDGE-130**

[P:SCI-PT-RS-05991 - Ch.5#5.1.5-SGEN-120 H/P

Materials shall have high resistance to stress corrosion cracking (SCC) for all structural applications but also for applications (like pretensioned springs or welded constructions which frequently include residual internal and assembly stresses) in which the materials are exposed for extended periods of time to tensile stresses in the terrestrial atmosphere or other potentially corrosive environments. The requirement also applies for GSE handling and lifting devices for loads higher than 30 kg.(SGEN-120)

*

Reference **GDGE-150**

[P:SCI-PT-RS-05991 - Ch.5#5.1.5-SGEN-125 H/P

Metals which are in direct contact with each other shall not form a galvanic couple with a difference of more than 0.5 volts Electro-Motive Force; in corrosive environments it shall not be more than 0.25 volts EMF. (SGEN-125)

*

Reference **GDGE-160**

[P:SCI-PT-RS-05991 - Ch.5#5.1.5-SGEN-130 H/P

As far as practicable, materials and mechanical parts shall be non-magnetic. In case magnetic materials must be used for a particular function the magnetic characteristics of the part will have to be determined and depending on the effects on system level, magnetic compensation methods might have to be applied. (SGEN-130)

*

Reference **GDGE-170**

[P:SCI-PT-RS-05991 - Ch.5#5.1.5-SGEN-135 H/P

Materials that are nutrient for fungus shall not be used when their use can be avoided. Where used and not hermetically sealed, these materials shall be treated with a suitable fungicide agent. (SGEN-135)

*

Reference **GDGE-180 a**

[P:SCI-PT-RS-05991 - Ch.5#5.1.5-SGEN-140 H/P

Materials which may constitute a safety hazard or can cause contamination shall not be used without specific approval by ESA. Examples of such materials are:

- B Beryllium-Oxide
- Cadmium

GENERAL DESIGN AND INTERFACE REQUIREMENTS (GDIR)

REFERENCE : H-P-1-ASPI-SP-0027

DATE : 25-Nov-2003

ISSUE : 4.2 PAGE : 25/118

- Zinc
- Mercury
- Radioactive Materials
- PVC

(SGEN-140)

*

3.4 Hardware production requirements

Reference **GDGE-190**

Each unit delivered for installation, assembly and integration into the satellite for qualification, flight and flight spare(s) shall meet the requirements of this specification and, in particular, will have passed the inspections and tests described in the applicable unit specification and in AD- 2.

*

3.5 Interchangeability

Reference **GDGE-200**

[P:SCI-PT-RS-05991 - Ch.5#5.1.6-SGEN-170 H/P

Each item of the spacecraft shall be directly interchangeable in form, fit and function with another item of the same part number (configuration item number). The performance characteristics and dimensions of like units shall be sufficiently uniform to permit interchange with a minimum of adjustment and re-calibration (SGEN-170)

*

3.6 Lifetime

Reference **GDGE-210**

[P:SCI-PT-RS-05991 - Ch.5#5.3.1.1-SPER-005 H

For the Herschel mission, the spacecraft shall have a nominal lifetime of 3. 5 years. This duration is counted from the launch to end of mission. This duration includes an allocation of 6 months for the transfer to the L-2 Lissajous orbit. (SPER-005)

*

Reference **GDGE-220**

[P:SCI-PT-RS-05991 - Ch.5#5.3.1.1-SPER-010 P

For the Planck mission, the spacecraft shall have a nominal lifetime of at least 21 months. This duration is counted from the launch to end of mission.

This duration shall allow two full sky surveys (with a coverage of at least 95% of the full sky) at the operational Lissajous orbit around L-2, and includes an allocation of 6 months for the transfer to the L-2 Lissajous orbit. (SPER-010)

*

GENERAL DESIGN AND INTERFACE REQUIREMENTS (GDIR)

REFERENCE : H-P-1-ASPI-SP-0027

DATE : 25-Nov-2003

ISSUE : 4.2

PAGE : 26/118

Reference **GDGE-230**

[P:SCI-PT-RS-05991 - Ch.5#5.3.1.1-SPER-020 H/P

The completely integrated Herschel and Planck spacecraft shall permit storage in a controlled facility before launch, prior to start of transport to the launch site, of 24 months. If required, helium refilling(s)/top-up(s) may be envisaged during this period. (SPER-020)

*

Reference **GDGE-240 a**

[P:SCI-PT-RS-05991 - Ch.5#5.3.1.2-SPER-025 H

The lifetime in orbit (from launch till the end of the mission) of Herschel items which degrade with time or usage shall be designed for 4.5 years, under nominal conditions (no additional margin is required).

*

Reference **GDGE-245**

[P:SCI-PT-RS-05991 - Ch.5#5.3.1.2-SPER-026 P

The lifetime in orbit (from launch till the end of the mission) of Planck items which degrade with time or usage shall be designed for 2.5 years, under nominal conditions (no additional margin is required). (SPER-026)

*

3.7 Maintainability, accessibility, reparability and testability

Reference **GDGE-250**

[P:SCI-PT-RS-05991 - Ch.5#5.1.6-SGEN-145 H/P

The design of the spacecraft shall consider the need for accessibility and the method to be employed for removal of units, placement of test aids, for equipment requiring adjustment or main-tenance with the aim of eliminating or minimising:

- the possibility of injury to personnel
- the possibility of damage to equipment or facility
- the possibility of incorrect assembly
- task complexity
- use of special tools or equipment
- use of non-standard hardware
- design complexity
- the need for special skills
- the activity duration

(SGEN-145)

*

Reference **GDGE-260**

[P:SCI-PT-RS-05991 - Ch.5#5.1.6-SGEN-150 H/P

GENERAL DESIGN AND INTERFACE REQUIREMENTS (GDIR)

REFERENCE : H-P-1-ASPI-SP-0027

DATE : 25-Nov-2003

ISSUE : 4.2 PAGE : 27/118

It shall be possible to access or remove equipment if it requires maintenance control with minimum disturbance to and interference with spacecraft or payload. (SGEN-150).

*

Reference **GDGE-270**

[P:SCI-PT-RS-05991 - Ch.5#5.1.6-SGEN-155 H/P

Items to be removed before flight (red. tag items) shall be visible after integration with the spacecraft. (SGEN-155).

*

Reference **GDGE-280**

[P:SCI-PT-RS-05991 - Ch.5#5.1.6-SGEN-160 H/P

Items requiring integration for safety, logistical or life reasons, close to the launch, shall be accessible without removing any equipment from the spacecraft (SGEN-160).

*

Reference **GDGE-290**

[P:SCI-PT-RS-05991 - Ch.5#5.1.6-SGEN-165 H/P

Items which require adjustment, servicing or maintenance before launch shall be accessible without removing any equipment from the spacecraft (SGEN-165).

*

Reference **GDGE-300**

[P:SCI-PT-RS-05991 - Ch.5#5.1.6-SGEN-175 H/P

Periodic maintenance requirements during storage and ground life shall be minimised and declared. (SGEN-175)

*

Reference **GDGE-310**

[P:SCI-PT-RS-05991 - Ch.5#5.1.6-SGEN-180 H/P

The spacecraft and its constituting modules/assemblies and sub-assemblies shall survive all environmental testing without the need for refurbishment. (SGEN-180)

*

3.8 Reliability, Fault Tolerance and Single Point Failures

Reference **GDGE-340**

[P:SCI-PT-RS-05991 - Ch.4#4.5-MOFM-010 H/P

No single failure in the software or the hardware of a subsystem/unit shall cause the loss of that subsystem/unit. (MOFM-010)

*

GENERAL DESIGN AND INTERFACE REQUIREMENTS (GDIR)

REFERENCE : H-P-1-ASPI-SP-0027

DATE : 25-Nov-2003

ISSUE : 4.2

PAGE : 28/118

Reference **GDGE-360**

[P:SCI-PT-RS-05991 - Ch.4#4.5-MOFM-020 H/P

Redundant units shall have a physical separation between them. If redundancy is implemented in the same box, a metallic separation is required. (MOFM-020)

*

Reference **GDGE-370**

[P:SCI-PT-RS-05991 - Ch.4#4.5-MOFM-025 H/P

Where redundancy is employed, the design shall allow to operate and verify the redundant item/function independently of the nominal use. (MOFM-025)

*

Reference **GDGE-380**

[P:SCI-PT-RS-05991 - Ch.4#4.5-MOFM-030 H/P

Each redundant path or function shall meet the full performance requirements. (MOFM-030)

*

Reference **GDGE-390**

[P:SCI-PT-RS-05991 - Ch.4#4.5-MOFM-035 H/P

Autonomous failure recovery shall not be based on a single sensor readout. (MOFM-035)

*

Reference **GDGE-400**

[P:SCI-PT-RS-05991 - Ch.4#4.5-MOFM-040 H/P

Switch over to redundant units shall be possible without reconfiguration of unrelated units (MOFM-040)

*

Reference **GDGE-410**

[P:SCI-PT-RS-05991 - Ch.4#4.5-MOFM-055 H/P

The spacecraft shall suppress uncontrolled recycling of error reaction functions (MOFM-055)

*

Reference **GDGE-420**

[P:SCI-PT-RS-05991 - Ch.5#5.3.4-SPER-080 H/P

Protection systems shall be intrinsically fail safe and shall be capable of being enabled and disabled by ground command. (SPER-080)

*

Reference **GDGE-430 a**

[P:SCI-PT-RS-05991 - Ch.4#4.5-MOFM-070 H/P

All relevant anomalies shall be properly detected and unambiguously reported.

GENERAL DESIGN AND INTERFACE REQUIREMENTS (GDIR)

REFERENCE : H-P-1-ASPI-SP-0027

DATE : 25-Nov-2003

ISSUE : 4.2 PAGE : 29/118

*

Reference **GDGE-432**

[P:SCI-PT-RS-05991 - Ch.4#4.5-MOFM-072 H/P

Spurious anomaly detection (false alarm) shall be avoided.

*

Reference **GDGE-440**

[P:SCI-PT-RS-05991 - Ch.4#4.5-MOFM-075 H/P

A clear and adequate fault reporting, shall be provided in the telemetry. (MOFM-075)

*

Reference **GDGE-450**

[P:SCI-PT-RS-05991 - Ch.4#4.5-MOFM-080 H/P

A clear and adequate fault diagnosis and identification, shall be provided. (MOFM-080)

*

Reference **GDGE-470**

[P:SCI-PT-RS-05991 - Ch.5#5.3.4-SPER-110 H/P

Compliance to the fault tolerance requirements shall be verified by FMECA or by other suitable methods, which are subject to agreement with ESA. (SPER-110)

*

The following requirements apply to internally redundant units :

Reference **GDGE-480**

[P:SCI-PT-RS-05991 - Ch.5#5.3.4-SPER-085 H/P

Cross strapping shall be incorporated in between chains of redundant units so that maximum overall reliability is achieved. (SPER-085)

*

Reference **GDGE-490**

Alternate or redundant paths shall be separated or protected such that an event that causes the loss of one functional path will not cause the loss or degradation of alternate, redundant serial paths.

*

3.9 Safety

Reference **GDGE-520 a**

By design, the units shall be capable of sustaining a failure and retaining the property not to cause injury to personnel or damage to the launch vehicle and satellite according to the requirements of AD-3.

*

GENERAL DESIGN AND INTERFACE REQUIREMENTS (GDIR)

REFERENCE : H-P-1-ASPI-SP-0027

DATE : 25-Nov-2003

ISSUE : 4.2 PAGE : 30/118

Reference **GDGE-530 a**

The units shall be designed and manufactured with compatible materials in such a manner that all hazards associated with the unit are eliminated or minimized and controlled according to the requirements of AD-3.

*

Reference **GDGE-540**

Applicable national standards on safety regulations or equivalent have to be observed.

*

3.10 Workmanship

Reference **GDGE-550**

Workmanship shall be such that the design standard is not degraded or changed. At all points during manufacturing integration, test, handling, storage and transportation, the design standard shall be maintained.

*

Reference **GDGE-560**

Manufacturing and process standard shall be in accordance with AD- 2.

*

Wherever possible and appropriate, requirements in respect of layout, finish and cleanliness shall be defined in the relevant specifications, drawings and/or process specifications. For satellite subsystem of qualification of flight application, the requirements shall be to the standards normally associated with space hardware.

Particular attention shall be paid in the consideration, definition, implementation and inspection of workmanship standards to:

- contamination
- surface finish
- elimination of sharp edges and burns
- routing and layout of wiring
- part mounting
- joint including soldered connections
- connector assembly
- conformal coating.

3.11 Identification and product marking

Reference **GDGE-570**

Each separately identifiable part or sub-assembly shall carry an identification consisting of at least the following information:

- Part/Unit Name
- End item number (this includes the Box Code)

GENERAL DESIGN AND INTERFACE REQUIREMENTS (GDIR)

REFERENCE : H-P-1-ASPI-SP-0027

DATE : 25-Nov-2003

ISSUE : 4.2

PAGE : 31/118

- Serial number and modification index
- Name of the Manufacturer
- Date of manufacture
- All marking shall be in English.

*

Reference **GDGE-580**

The identification shall be mounted on the connector face, visible when installed on the unit and its location shall be noted on the Interface Control Drawing for the unit. The identification shall be legible with unaided eye from 0.5 m distance. The identification label shall meet all the requirements relevant to any equipment.

*

3.12 Cleanliness

Reference **GDGE-590 a**

Edge of Honeycomb panels shall be covered by Kapton foil or foam FM410-1 in accordance with the cleanliness requirements, except for Planck solar array panels.

*

Reference **GDGE-600**

External cleanliness is required for all satellite and GSE units to be entered in clean room. Refer to AD- 5.

*

3.13 Handling, Packing and Transportation

Reference **GDGE-610**

The design of the equipment shall make easy integration, transportation and access to connectors and fixation points for the operators during AIT.

*

Reference **GDGE-620**

During transportation of hardware, packing and special precautions shall be such that the environments specified in AD- 1 can be withstood. Packing provisions shall prevent damage and contamination during transportation. Special covers shall protect optics, connectors, mounting surfaces subject to alignment procedures and all sensitive parts.

*

Reference **GDGE-630**

The container for the units shall be labelled, tagged or marked to allow detailed identification of the contents of the container.

*

GENERAL DESIGN AND INTERFACE REQUIREMENTS (GDIR)

REFERENCE : H-P-1-ASPI-SP-0027

DATE : 25-Nov-2003

ISSUE : 4.2

PAGE : 32/118

3.14 Radiations

The radiation environment is defined in the Environment Requirements Specification (AD- 1). Due to the specificity of the mission around L2, the spacecraft will only cross the Earth's radiation belts once during LEOP. However, it will still be exposed to energetic protons and heavy ions from solar flares and cosmic rays.

The principal anticipated radiation effects are:

- Degradation of electronic components, detectors and materials (dose effect),
- Interference with detector operation (background)
- Cosmic rays induced upsets
- Latchup
- Electrostatic charging

Reference **ENVR-005**

[P:SCI-PT-RS-05991 - Ch.5#5.5.5-SENV-080 H/P

The contractor shall be responsible for performing radiation analyses as required using the nominal mission scenario and taking into account the data from the Herschel L2 Radiation Environment document (AD- 1). The in-orbit case with a beginning of mission in February 2007 shall be taken into account.

*

In particular, the figures related to the Silicon Solar cells, Gallium Arsenide cells, single dose/depth, non-ionising dose/depth and raw particle spectra shall be taken into account. (SENV-080)

3.14.1 Radiation Dose

Reference **ENVR-010**

[P:SCI-PT-RS-05991 - Ch.5#5.5.5.1-SENV-085 H/P

The satellite shall be designed to withstand the doses predicted for a 2 times the nominal lifetime of the spacecraft except for the solar array sizing.(SENV-085).

*

Reference **ENVR-020**

[P:SCI-PT-RS-05991 - Ch.5#5.5.5.1-SENV-090 H/P

The components and their shielding shall be compatible with the above requirement such that the radiation dose will not cause failures or produce unacceptable changes in performance. (SENV-090)

*

Reference **ENVR-030**

[P:SCI-PT-RS-05991 - Ch.5#5.5.5.1-SENV-095 H/P

For the design of the solar array and the determination of its degradation during the mission, the total equivalent fluence of 1 MeV electrons shall be taken into account for the extended lifetime. (SENV-095)

*

GENERAL DESIGN AND INTERFACE REQUIREMENTS (GDIR)

REFERENCE : H-P-1-ASPI-SP-0027

DATE : 25-Nov-2003

ISSUE : 4.2 PAGE : 33/118

Reference **ENVR-040**

[P:SCI-PT-RS-05991 - Ch.5#5.5.5.1-SENV-100 H/P

Components shall be qualified (either based on existing or new test data) to withstand the doses predicted according to ENVR-010 (SENV-085). Radiation testing shall be included in the lot acceptance testing, if the margin is small and if the variation of radiation resistance between lots is large or insufficiently known. An exception to this requirement is the solar cells which shall be qualified according to AD- 21 for Silicon Solar Cells and AD- 22 for Gallium Arsenide Solar Cells.(SENV-100)

*

3.14.2 Radiation induced background

Radiation impinging onto a detector or its associated electronics can produce an increase in noise, which in turn can produce a significant decrease of performance. Such changes can last until well after the radiation dose has stopped (remittances).

Reference **ENVR-050**

[P:SCI-PT-RS-05991 - Ch.5#5.5.5.2-SENV-105 H/P

The spacecraft design and component selection shall be such as to minimise these effects, including any necessary means to ensure the most rapid restoration of nominal performance. (SENV-105)

*

3.14.3 Single Event Effects

Single event effects are due to heavy ions and protons from galactic and extra galactic sources and solar flares protons. Its effects on electronic components may be destructive (latch-up) or non-destructive (bit flips).

The applicable environment curves are given in AD- 1.

The methodology to be applied for single events (SEL, SEU) rate prediction is provided in AD- 6.

3.14.3.1 Single event latch-up

Cosmic rays may cause latch-up in certain technologies, primarily CMOS. Latch-up is permanent and potentially destructive.

Reference **ENVR-060**

[P:SCI-PT-RS-05991 - Ch.5#5.5.5.4-SENV-135 H/P

Devices which are known or proven to be susceptible to latch-up shall not be used. (SENV-135)

*

Reference **ENVR-070**

Components of technology sensitive to heavy ions or protons shall be submitted to evaluation in order to qualify their latch-up occurrence rate.

*

Reference **ENVR-080**

[P:SCI-PT-RS-05991 - Ch.5#5.5.5.4-SENV-135 H/P

GENERAL DESIGN AND INTERFACE REQUIREMENTS (GDIR)

REFERENCE : H-P-1-ASPI-SP-0027

DATE : 25-Nov-2003

ISSUE : 4.2

PAGE : 34/118

In the case where technical demands can only be met using latch-up sensitive technologies, a de-latching device shall be implemented so as to avoid loss of the unit upon latch-up. (SENV-135)

*

3.14.3.2 Single event burn-out and single event gate rupture

N channel power MOSFETs are sensitive to single event burn-out and single event gate rupture, while P channel ones are only sensitive to single event gate rupture.

Reference **ENVR-090**

Appropriate derating rules shall be applied as per AD- 40.

*

3.14.3.3 Single event upset (SEU)

Reference **ENVR-100**

[P:SCI-PT-RS-05991 - Ch.5#5.5.5.3-SENV-120 H/P

[P:SCI-PT-RS-05991 - Ch.5#5.5.5.3-SENV-110 H/P

When components sensitive to SEU are selected, the design shall take care that solutions to prevent the effects of SEU on the mission are implemented into the equipment as hardware solutions (particularly through component selection) or as software solutions. (SENV-110, SENV-120)

*

Reference **ENVR-110**

The availability computation shall account for possible SEU effects and shall demonstrate that the availability requirement is fulfilled.

*

Reference **ENVR-120**

SEU shall not cause permanent failure or degradation either directly or as a consequence.

*

Reference **ENVR-130**

[P:SCI-PT-RS-05991 - Ch.5#5.5.5.3-SENV-110 H/P

All computers shall be protected against the effects of SEU.

*

Reference **ENVR-140**

[P:SCI-PT-RS-05991 - Ch.5#5.5.5.3-SENV-120 H/P

The computers memory architecture shall be such that a MEU inducing a flip of more than two (2) bits in the same word shall not lead to the loss of the mission. MEU : Multiple Even Upset, i.e. the consequence of a heavy ion causing more than one simultaneous bit flip in the same chip.

*

GENERAL DESIGN AND INTERFACE REQUIREMENTS (GDIR)

REFERENCE : H-P-1-ASPI-SP-0027

DATE : 25-Nov-2003

ISSUE : 4.2 PAGE : 35/118

Reference **ENVR-150**

[P:SCI-PT-RS-05991 - Ch.5#5.5.5.3-SENV-115 H/P

The rate of uncorrectable errors in spacecraft memories shall be better than 1E-11 (error/bit/day). (SENV-115)

*

Reference **ENVR-160 a**

[P:SCI-PT-RS-05991 - Ch.5#5.5.5.3-SENV-125 H/P

All spacecraft processor semiconductor memories and registers shall implement Single Error Correction and Double Error Detection (SECCDED) for each smallest addressable unit in memory.

*

Reference **ENVR-170**

[P:SCI-PT-RS-05991 - Ch.5#5.5.5.3-SENV-130 H/P

The processor design shall ensure that the processor internal registers are refreshed at a rate sufficient to avoid cumulation of deposited charges leading to errors. (SENV-130)

*

3.15 Electrostatic charging

Reference **ENVR-180**

[P:SCI-PT-RS-05991 - Ch.5#5.5.5.5-SENV-140 H/P

Spacecraft design and materials selected shall be such as to ensure that no parts of the spacecraft are charged to high potentials. (SENV-140)

*

Reference **ENVR-190**

[P:SCI-PT-RS-05991 - Ch.5#5.5.5.5-SENV-145 H/P

All spacecraft surfaces exposed to the plasma environment shall be conductive and grounded to the spacecraft structure.

Agreed exceptions are: Solar Arrays. (SENV-145)

*

3.16 Debris

Reference **ENVR-200**

The generation of space debris by structural breakup shall be minimised. Suitable means of debris containment shall be included.

*

4. MECHANICAL DESIGN AND INTERFACE REQUIREMENTS

4.1 Mechanical reference frames

4.1.1 Satellite Axes Definition

4.1.1.1 Herschel

The Herschel satellite reference frame (O, X_s, Y_s, Z_s) is defined such that :

- O is located at the center of the launch vehicle interface ring, on the separation plane
- X_s coincides with the nominal optical axis of the Herschel telescope. Positive X_s axis is oriented towards the target source. The X_s axis coincides with the launcher longitudinal axis.
- Z_s is in the plane orthogonal to the X_s axis, such that nominally the Sun will lie in the (X_s, Z_s) plane (zero roll angle with respect to Sun). Positive Z_s axis is oriented towards the Sun.
- Y_s completes the right handed orthogonal reference frame.

See Figure 4-1.

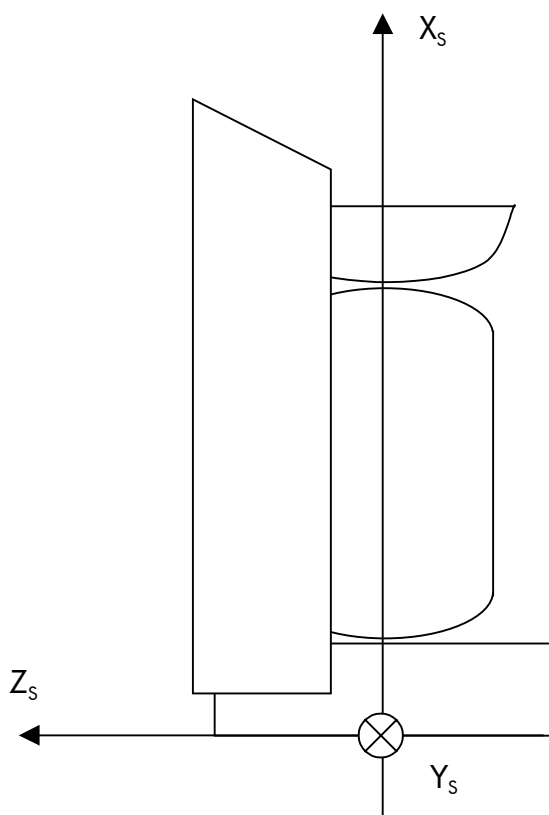

Figure 4-1: Herschel Spacecraft Axes

4.1.1.2 PLANCK

The PLANCK satellite reference frame (O, X_s, Y_s, Z_s) is defined such that :

- O is located at the center of the launch vehicle interface ring, on the separation plane
- X_s coincides with the nominal spin axis of PLANCK. Positive X_s axis is oriented opposite to the Sun in nominal operation. The X_s axis coincides with the launcher longitudinal axis.
- Z_s is perpendicular to X_s and contained in the symmetry plane of the telescope, with the positive direction on the concave side of the primary mirror of the telescope
- Y_s completes the right handed orthogonal reference frame.

See Figure 4-3.

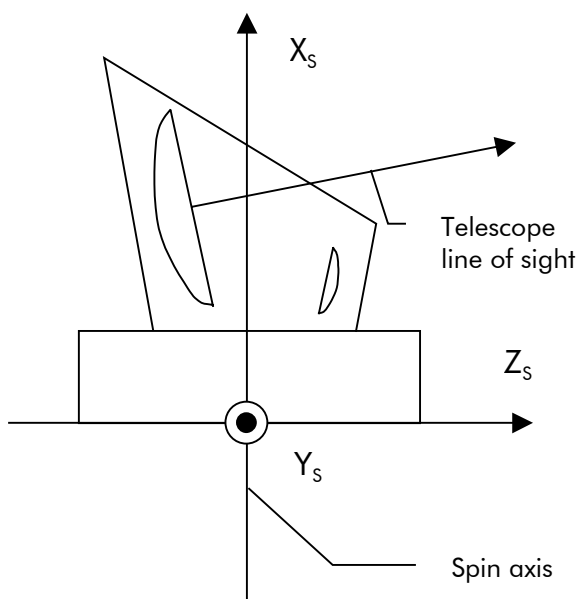
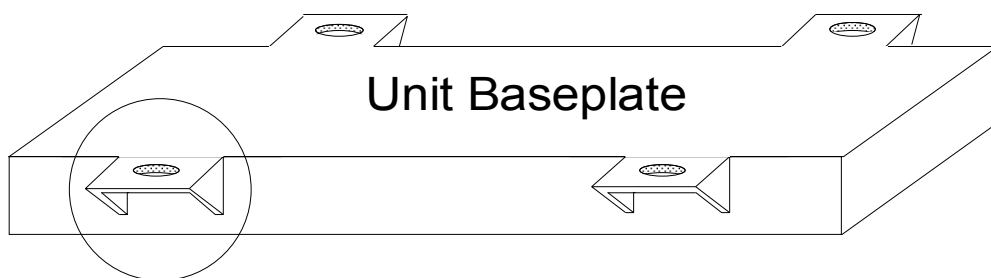

Figure 4-3: PLANCK Spacecraft Axis

4.1.2 Unit reference frame

A unit reference frame is defined with the (X_u, Y_u) plane defined as the plane of the unit mounting and the Z_u axis perpendicular to this plane in the direction from it to the unit. The origin of the unit reference frame is at the centre of the reference hole (see Figure 4-5).



Reference Hole

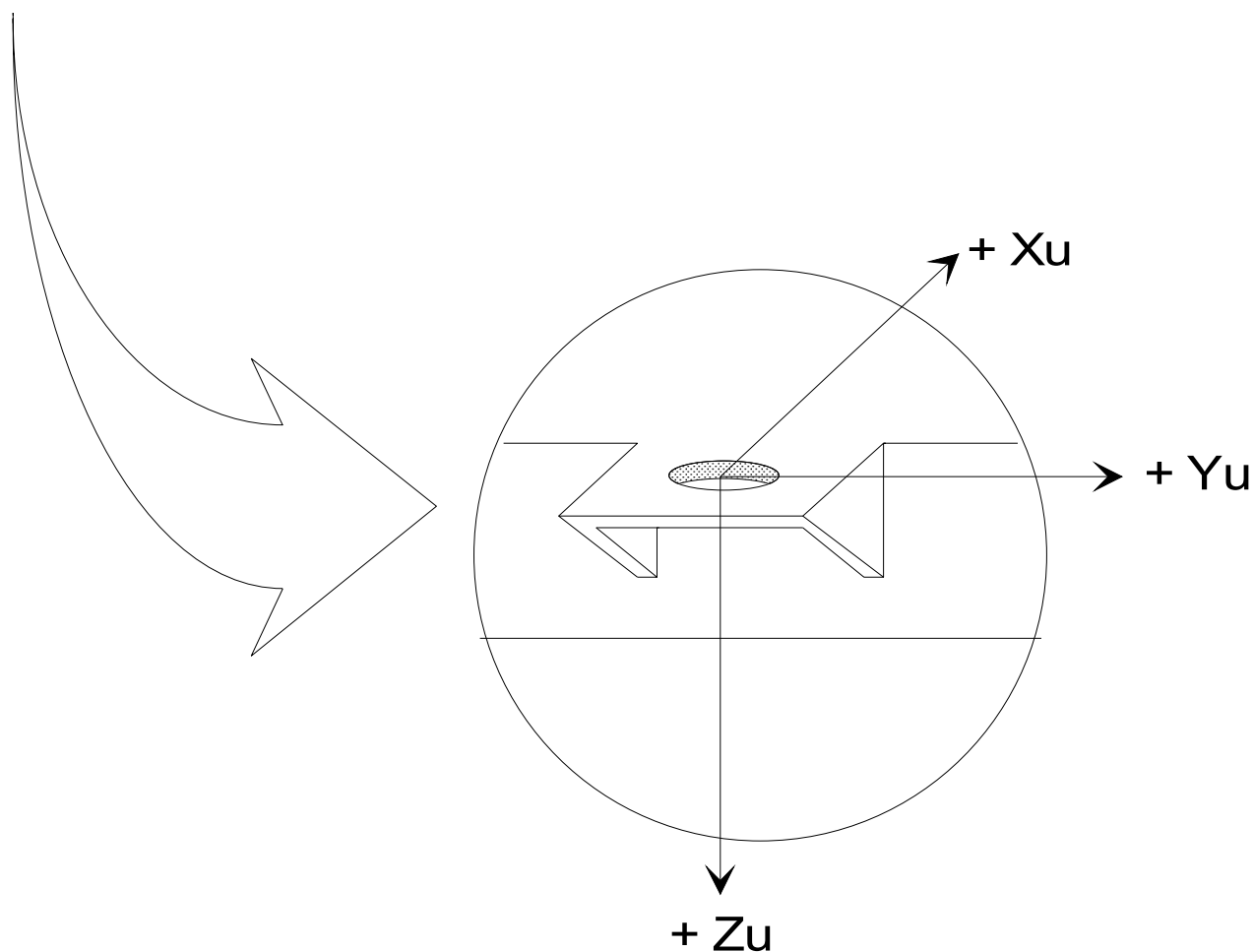

Figure 4-5: Unit Reference Frame

4.2 General requirements

Reference **GDME-005**

[P:SCI-PT-RS-05991 - Ch.5#5.5.1-SENV-015 H/P

The Herschel/Planck composite shall be designed to withstand all mechanical static and dynamic loads encountered during its entire life, including: manufacturing, assembly, handling, transportation, testing, launch and in-orbit operations. (SENV-015)

GENERAL DESIGN AND INTERFACE REQUIREMENTS (GDIR)

REFERENCE : H-P-1-ASPI-SP-0027

DATE : 25-Nov-2003

ISSUE : 4.2

PAGE : 39/118

*

4.3 Handling provisions

Reference **GDME-010**

Lifting and transportation interfaces shall be arranged such that, except for the points themselves, ground handling loads shall not be a design governing requirement for the Probe.

*

Reference **GDME-020**

The satellites lifting points shall permit handling of the satellites as in all orientations necessary for assembly, integration, test and transport. Positioning of points shall be such that satellite integration shall not limit the handling capability of the integrated spacecraft.

*

Reference **GDME-030**

Each unit weighing more than 10 kg shall be equipped with handling points (e.g. threaded bushes) that enable the connection to special handling MGSE for integration or dismounting.

*

Reference **GDME-040**

Positioning of these points shall be such that unit integration shall not limit the handling capability of the integrated satellite.

*

4.4 Units physical characteristics

For mass properties (mass, center of mass, inertia) the term "nominal" refers to the current best estimate, either calculated or measured depending on the development progress.

4.4.1 Mass

Reference **GDME-050 a**

[P:SCI-PT-RS-05991 - Ch.5#5.6.1.5-SCMD-080 H/P

The total spacecraft mass shall be minimised wherever reasonable and shall include, at the beginning of phase B, a margin on each spacecraft elements depending on the development status of those elements as follows :

- Completely new developments : 20%
- New developments derived from existing hardware : 15%
- Existing units requiring minor/medium modification or units passed PDR : 10%
- Existing units or units passed CDR : 5%

The propellant masses shall be determined on the basis of dry mass including the above contingencies and shall itself include the lifetime margins :

GENERAL DESIGN AND INTERFACE REQUIREMENTS (GDIR)

REFERENCE : H-P-1-ASPI-SP-0027

DATE : 25-Nov-2003

ISSUE : 4.2

PAGE : 40/118

- Launcher dispersion compensation propellant : 5%
- Orbit insertion propellant : 0%
- Orbit maintenance propellant : 50%
- Angular momentum management/attitude control : 50%

*

Reference **GDME-060**

The nominal mass of each unit, with tolerances, shall be given in the unit Interface Data Sheet (see Appendix 1).

*

Reference **GDME-070**

[P:SCI-PT-RS-05991 - Ch.5#5.1.4-SGEN-070 H/P

The actual mass of all units intended for Qualification, Flight and Flight Spare(s) shall not deviate from the nominal value by more than:

- 0.5 % for masses > 20 kg
- 0.1 kg for masses > 10 kg and < 20 kg
- 1 % for masses > 1 kg and < 10 kg
- 10 g for masses < 1 kg.

For the SVM structure, the actual mass of all units intended for Qualification, Flight and Flight Spare(s) shall not deviate from the nominal value by more than:

- 1 % for the total SVM structure
- 2 % for composite parts of the SVM structure (e.g. central tubes, lateral panels...)

The masses shall be measured with an accuracy of:

- ± 0.1 % for masses > 50 kg
- ± 0.05 % for masses > 10 kg and < 50 kg
- ± 1 g for masses > 0 kg and < 10 kg.

*

4.4.2 Centre of mass

Reference **GDME-080**

The nominal location of the center of mass of each unit, with tolerances, shall be given in the unit Interface Data Sheet (see Appendix 1).

*

Reference **GDME-090**

The location of the center of mass for equipment intended for EM, Flight and Flight Spare(s) must not deviate from the nominal location by more than 1.0 mm radius sphere.

*

GENERAL DESIGN AND INTERFACE REQUIREMENTS (GDIR)

REFERENCE : H-P-1-ASPI-SP-0027

DATE : 25-Nov-2003

ISSUE : 4.2 PAGE : 41/118

Reference **GDME-100**

The centre of mass location shall be measured with an accuracy of 0.5 mm.

*

4.4.3 Moments of inertia

Reference **GDME-110**

Nominal moments of inertia of each unit, with tolerances, shall be recorded in the unit Interface Data Sheet (see Appendix 1).

*

Reference **GDME-120**

The value of the moments of inertia of equipment intended for Qualification, Flight and Flight Spare(s) must not deviate from the nominal value by more than 10% except for equipment having a moment of inertia lower than 0.1 kg.m² for which calculated values may be supplied.

*

Reference **GDME-130**

[P:SCI-PT-RS-05991 - Ch.5#5.1.4-SGEN-070 H/P

The moments of inertia shall be measured with an accuracy of $\pm 5\%$.

*

4.4.4 Size

Reference **GDME-140**

All interface dimensional properties must be indicated on Interface Control Drawings.

*

Reference **GDME-150**

The overall dimensions and associated tolerances of unit including interface assembly, shall not differ from the values stated in the Interface Data Sheets (see Appendix 1).

*

4.5 Unit Layout and interfaces

The layout of each unit shall take into account:

- electrical requirements
- thermal control requirements
- alignment and centre of mass requirements
- vibration requirements
- easy access to electrical connectors

GENERAL DESIGN AND INTERFACE REQUIREMENTS (GDIR)

REFERENCE : H-P-1-ASPI-SP-0027

DATE : 25-Nov-2003

ISSUE : 4.2

PAGE : 42/118

- easy access to fasteners
- easy mounting and removal
- provision to avoid mismatching
- flatness etc...

Reference **GDME-160**

The unit layout and method of fixation shall be indicated on the Interface Data Sheets (see Appendix 1).

*

4.6 Structural design

4.6.1 Definitions

Primary structures

The primary structures are the main flight Loads paths and define the major structural frequencies

Secondary structures

The secondary structures are not responsible for the main load transfer. They are fastened to the primary structure, and transfer unit Loads to the primary structure

Unit/Equipment structures

Unit/Equipment structures are those belonging to self standing items such as experiment units and sensors, mechanisms, subsystem components and electronic boxes.

4.6.2 **Stiffness requirements**

Reference **GDME-180**

[P:SCI-PT-RS-05991 - Ch.5#5.6.1.1-SCMD-010 H/P

The eigenfrequencies of compact equipment and boxes in hard-mounted condition shall be above 140 Hz. (SCMD-010)

*

4.6.3 **Strength requirements**

Reference **GDME-190 a**

[P:SCI-PT-RS-05991 - Ch.5#5.1.4-SGEN-055 H/P

The structural strength dimensioning shall take into account the masses given in Table 4-0.

GENERAL DESIGN AND INTERFACE REQUIREMENTS (GDIR)

REFERENCE : H-P-1-ASPI-SP-0027

DATE : 25-Nov-2003

ISSUE : 4.2 PAGE : 43/118

	Mass for strength calculation (kg)
Dry Herschel SVM (including instrument warm boxes)	703
Herschel fuel	200
Dry Planck SVM (including instrument warm boxes)	953
Planck fuel	402
H-EPLM (including telescope, instruments and Helium)	2487
P-PLM (including reflectors and FPU)	388

Table 4-0 : Mass for structural strength dimensioning

*

Reference **GDME-200**

[P:SCI-PT-RS-05991 - Ch.5#5.6.1.2-SCMD-015 H/P

The spacecraft shall be able to withstand the mechanical environment as deduced from the coupled analysis with the launcher. (SCMD-015)

*

Reference **GDME-220**

[P:SCI-PT-RS-05991 - Ch.5#5.6.1.2-SCMD-025 H/P

The structure shall withstand at element, subassembly, or complete spacecraft level the following:

- the ultimate loads without rupture, collapse or permanent deformations that impact the integrity of other parts or the system performance
- the yield loads, where applicable, without permanent deformation or any plastic deformation resulting in performance degradation
- the buckling loads without elastic buckling or collapse taking into account a non perfection of the failing element, e.g. by knock-down factor

(SCMD-025)

*

Reference **GDME-230**

[P:SCI-PT-RS-05991 - Ch.5#5.6.1.2-SCMD-035 H/P

The spacecraft structure shall withstand the complete set of tests at qualification level with sufficient margins without the need of any refurbishment for flight. (SCMD-035)

*

GENERAL DESIGN AND INTERFACE REQUIREMENTS (GDIR)

REFERENCE : H-P-1-ASPI-SP-0027

DATE : 25-Nov-2003

ISSUE : 4.2

PAGE : 44/118

4.6.4 Safety factors

Reference **GDME-240 a**

[P:SCI-PT-RS-05991 - Ch.5#5.6.1.3-SCMD-045 H/P

[P:SCI-PT-RS-05991 - Ch.5#5.6.1.3-SCMD-040 H/P

Safety Factors (SF) shall account for inaccuracies in predicted allowable and applied stresses due to:

- analysis uncertainties,
- manufacturing tolerances,
- scatter in material properties,
- setting at interface.

The safety factors as presented in Table 4-1 shall be applied to the design limit loads :

- yield SF (YSF) against permanent deformation,
- ultimate SF (USF) against rupture and loss of functionality,
- buckling SF (BSF) against elastic buckling or collapse.

Item	YSF	USF	BSF
Conventional metallic materials	1.1	1.5	2.0
Unconventional materials	1.4	2.0	2.0
Inserts and joints	1.5	2.0 (*)	NA
Sliding	NA	1.5	NA

Table 4-1 : Basic Safety Factors

(*) Standard inserts as defined in the Insert Design Handbook PSS-03-1202 may use a safety factor USF = 1.5 against minimum "A" ultimate capabilities.

*

The conventional and non-conventional materials are defined as follows :

Conventional materials:

All materials, also composites, provided sufficient statistical data are available to derive A values as defined in the MIL-HDBK-5 section 1.4.11.

Unconventional materials:

All those materials for which sufficient statistical data are not available.

4.6.5 Loads and margins of safety

The following loads are defined :

- Limit Loads: limit loads are the load combinations which have a 99% probability of not being exceeded during the entire life of the structure, including manufacturing, handling, transportation, ground testing, launch and in-orbit operations

GENERAL DESIGN AND INTERFACE REQUIREMENTS (GDIR)

REFERENCE : H-P-1-ASPI-SP-0027

DATE : 25-Nov-2003

ISSUE : 4.2 PAGE : 45/118

- Design Loads: design loads are simplified load cases which shall envelope the limit loads and the qualification loads of the environmental testing
- Preliminary Design Loads: preliminary design loads are the design loads to initiate the design phase.
- Yield loads: yield loads are design loads multiplied by the yield safety factor.
- Ultimate loads: ultimate loads are design loads multiplied by the ultimate safety factor
- Buckling loads: buckling loads are design loads multiplied by the buckling safety factor.

Reference **GDME-260 a**

[P:SCI-PT-RS-05991 - Ch.5#5.6.1.4-SCMD-070 H/P

The Margin of Safety (MOS) shall be calculated according to Equation 4-1.

$$MOS = \frac{(RelevantStrengthCapability)}{(RelevantLoad)} - 1$$

Equation 4-1 : MOS

*

The Yield Margin of Safety (YMOS) compares the yield strength capability of the structural elements to the yield loads.

The Ultimate Margin of Safety (UMOS) compares the ultimate strength capability of the structural elements to the ultimate loads.

The Buckling Margin of Safety (BMOS) compares the buckling strength capability of the structural elements to the buckling loads.

The Strength Capability is the load which exactly induces the design allowable stresses for the material.

Reference **GDME-270**

[P:SCI-PT-RS-05991 - Ch.5#5.6.1.4-SCMD-075 H/P

The material Design Allowable shall correspond to the A-values as defined in document MIL-HDBK-5. The Contractor shall perform material testing as necessary to establish the Design Allowable. The test programme and interpretation of the results are subject to ESA approval. (SCMD-075)

*

4.6.6 Preliminary design loads

Reference **GDME-280 b**

[P:SCI-PT-RS-05991 - Ch.5#5.6.1.4-SCMD-065 H/P

The Herschel and Planck secondary structure items shall be preliminary designed to support the loads defined at qualification level in Table 4-3.

Secondary structure items	Preliminary design loads (qualification level)
Unit brackets and attachments	30 g spherical envelope
Antenna booms, flexible units	50 g spherical envelope

Table 4-3: Preliminary design loads

Secondary structure items with the SVM will be designed as per RD-10.

*

4.7 Alignment

4.7.1 Alignement provisions

Reference **GDME-290**

The following points shall be observed for any equipment requiring positioning accuracy on the structure:

- at least 2 positioning points and when necessary shims shall be provided with location and tolerance consistent with positioning requirements
- the Contractor for the equipment shall specify the alignment tolerances between the mating and the sensitive axis as well as between the dowel line and the sensitive axis (e.g. thrust axis)
- the Contractor for the equipment shall provide the Contractor for the structure with a drilled template in accordance with the dowel positioning
- should some accurate items require alignment adjustment in situ the relevant Contractor shall formulate a request to the Prime Contractor with proper justification. The adjustment process shall be defined in each case by common agreement between the Contractor and the Prime Contractor.

*

4.7.2 Alignment with mirror

Reference **GDME-300**

Any unit that requires an accuracy of alignment of $\pm 0.15^\circ$ or better shall have optical reference reflectors. The location of the mirror shall be identified in assembly drawings and Interface Control Drawings.

*

Reference **GDME-310**

The following points shall be observed in designing unit optical references:

- each unit requiring alignment about 2 axis shall carry a reflecting mirror parallel to the plane containing those 2 axes or two reflecting mirrors (see note (1)), each one perpendicular (see note (3)) to the relevant axis; details will be as specified in Interface Control Drawings
- each unit requiring alignment about 3 axis shall carry two (see note (2)) perpendicular (see note (3)) reflecting mirrors
- the direction of the axes of the optical reference shall be known relative to the direction of the unit axis to an accuracy as described in the unit Specification
- the reflecting surfaces shall be optically polished and flat to within $\lambda/4$ (λ : wavelength of the sodium yellow line)
- when two or more reflecting surfaces are provided, it is preferable to use an optical cube. Notes (1) to (3) apply

GENERAL DESIGN AND INTERFACE REQUIREMENTS (GDIR)

REFERENCE : H-P-1-ASPI-SP-0027

DATE : 25-Nov-2003

ISSUE : 4.2 PAGE : 47/118

- the optical references shall have a minimum diameter of 15 mm and a minimum thickness of 4 mm.

The fixation of the alignment mirrors shall allow the alignment of the concerned unit on the integrated spacecraft (see note (1)). The fixation of the alignment mirrors shall be compatible with mechanical and thermal vacuum testing environment, and with outgassing requirements.

NOTES:

- (1) The two reflecting mirrors shall be positioned after agreement of the Prime Contractor in order to ensure they can be used when integrated on the satellite.
 - (2) If only two or three reflecting mirrors are provided the note (1) shall apply. If four or five reflecting mirrors are provided, the note (1) does not apply.
 - (3) Perpendicularity of reflecting surfaces shall be ± 10 arc sec.
-

*

4.8 Unit fixation

4.8.1 Functional requirements

Reference **GDME-320**

The attachment points shall provide a controlled surface contact between the units and the structure to allow control of thermal conditions on the unit as well as electrical bonding.

*

4.8.2 Lug general design characteristics (boxes)

Reference **GDME-330 a**

The lugs shall be designed according to Figure 4-7.

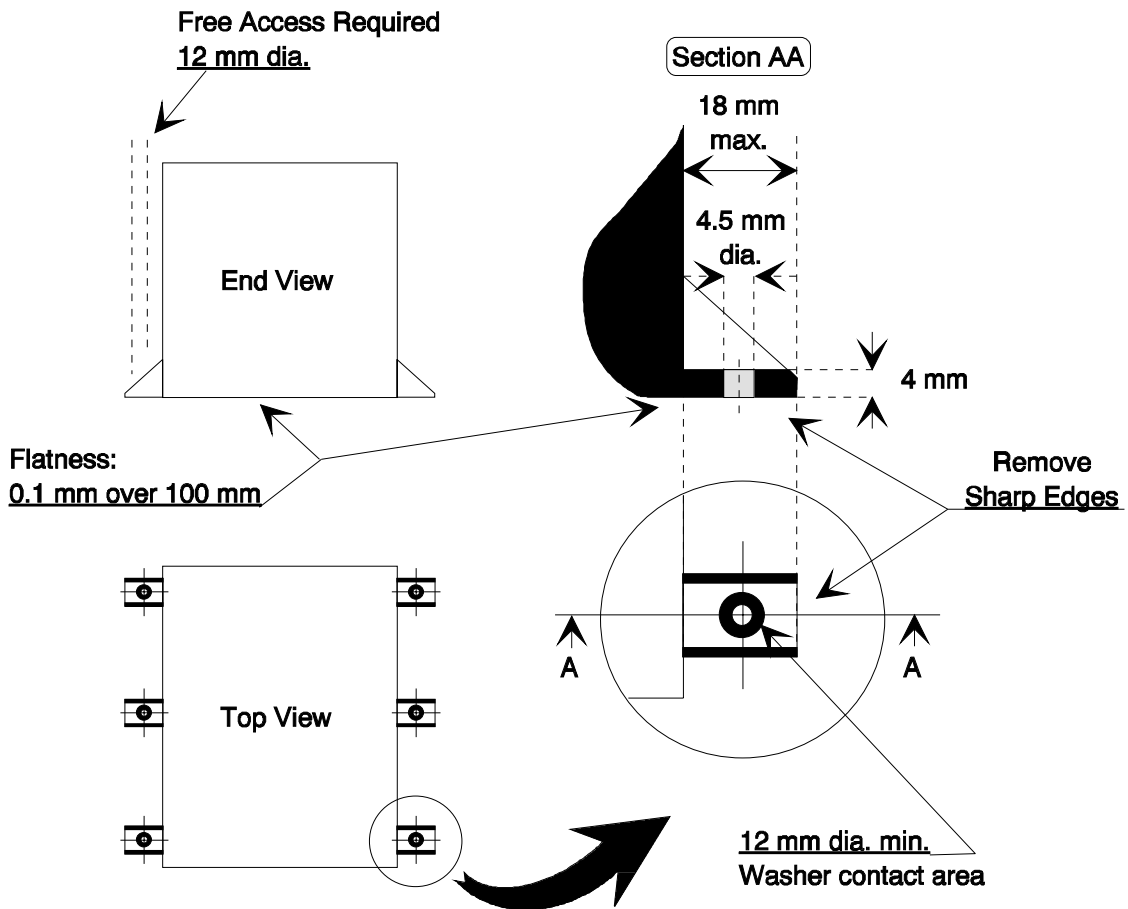

Figure 4-7: Unit Lug Interface Design

*

Reference **GDME-340**

One of the holes shall be identified as reference hole and shall be marked with the capital letter R on the Interface Control Drawing.

*

Reference **GDME-350 a**

The box co-ordinates and the centre of mass co-ordinates shall be related to the reference hole. The positive Z-axis shall be normal to the mounting surface, as defined in Figure 4-5.

*

Reference **GDME-360 b**

Boxes with a mass < 1.5 kg shall not have more than 4 attachment points.

The definition of the boxes attachment points shall comply with the following mechanical requirements, under application of the worst case of mechanical and thermal environments:

- no sliding at support structure interface, compatible with screws capabilities as defined in §4.8.4 according to the criteria of Equation 4-2.

GENERAL DESIGN AND INTERFACE REQUIREMENTS (GDIR)

REFERENCE : H-P-1-ASPI-SP-0027

DATE : 25-Nov-2003

ISSUE : 4.2

PAGE : 49/118

$$USF \frac{P + Q}{P_t} \leq 1$$

Equation 4-2 : No sliding criteria (using USF for sliding)

- design loads at attachment points compatible with inserts loads capabilities as defined in §4.8.4, according to the criteria of Equation 4-3.

$$USF \sqrt{\left(\frac{P}{P_m}\right)^2 + \left(\frac{Q}{Q_m}\right)^2 + \left(\frac{M}{M_m}\right)^2} \leq 1$$

Equation 4-3 : Design loads at attachment points criteria (using USF for joints)

where,

- **USF** are the Ultimate Safety Factors defined in GDME-240.
- **P** and **Q** are the actual values of axial and lateral loads applied to the attachment bolt.
- **P_t** is the minimum guaranteed screw tension specified in GDME-445.
- **ρ** is the friction coefficient between the box and its support structure, as defined in Table 4-5.

support structure	Aluminium box	
	with alodine 1200S coating	plated A5
aluminium with alodine 1200S coating	ρ max = 0.23	ρ max = 0.23
aluminium plated A5	ρ max = 0.23	ρ max = 0.23
CFRP	ρ max = 0.2	ρ max = 0.2

Table 4-5: Friction coefficient values

- **P_m**, **Q_m** and **M_m** are the insert strength capability specified by the SVM Contractor.
- P_m in tension to be used to check no sliding criteria.
- P_m in tension or compression to be used, depending of the equipment feet design, to check compatibility with inserts loads capabilities.

The equipment design shall prevent single inserts loading in bending and torsion.

The number and pattern of boxes attachment points is to be approved by the Prime Contractor.

*

Reference **GDME-370**

For highly dissipative equipment the number and location of attachment point shall be chosen according to thermal considerations.

*

GENERAL DESIGN AND INTERFACE REQUIREMENTS (GDIR)

REFERENCE : H-P-1-ASPI-SP-0027

DATE : 25-Nov-2003

ISSUE : 4.2

PAGE : 50/118

4.8.3 Lug interface

Reference **GDME-380**

The distance between two adjacent lugs shall be smaller than 300 mm but not closer than 30 mm and in accordance with the Interface Control Drawings (ICD).

*

Reference **GDME-390**

The location of each attachment hole centre w.r.t. the Reference Hole, shall be within a 0.2 mm diameter circle centred on the theoretical position.

*

Reference **GDME-400**

The lugs and clearance for mounting shall be dimensioned as shown in Figure 4-7. No part of the box shall be in the volume above the lugs indicated as "free access required".

*

Reference **GDME-410**

The contact area shall be specified on the ICD for each attachment point.

*

Reference **GDME-420**

For highly dissipative equipment, this area shall have to be agreed by Prime Contractor according to thermal subsystem needs. The Lug edge shall be rounded to minimum radius of 0.2 mm to avoid structural damage.

*

Reference **GDME-430**

The coplanarity of the lugs shall be within 0.1 mm/100 mm.

*

4.8.4 Fixation hardware

Reference **GDME-440 a**

Each unit shall be mounted with as many M4 female bi-hexagonal screws as needed to ensure a ratio "unit maximal mass / number of attachment points" below 1.5 kg.

Any deviation to this mass per attachment point shall be reported to the Prime. Screws with a higher diameter of type M5, M6 or M8 will then have to be considered.

*

Reference **GDME-445**

The screws used for unit mounting shall be tightened up with a tension **P** higher than **P_r**, given in Table 4-6.

GENERAL DESIGN AND INTERFACE REQUIREMENTS (GDIR)

REFERENCE : H-P-1-ASPI-SP-0027

DATE : 25-Nov-2003

ISSUE : 4.2

PAGE : 51/118

Screw type	M4	M5	M6	M8
Minimum guaranteed screw tension P_t (N)	4 000	6 200	8 500	17 500

Table 4-6 : Screw capability

*

Reference **GDME-450 b**

Deleted.

*

Reference **GDME-460 b**

Deleted.

*

Reference **GDME-470**

Compliance with these load requirements shall be shown in the ICD. Any exception must be approved by the Prime Contractor.

*

Reference **GDME-480 a**

Spacecraft equipment fixation points shall provide threads characteristics as defined in Table 4-11 and Table 4-13.

Standard	<u>Thread length (min.) - mm</u>	<u>Bolt clearance (min.) - mm</u>	Helicoil	Locking device
M4	7.5	<u>2 D</u>	<u>with</u>	<u>with</u>
M5	9.5	<u>2 D</u>	<u>with</u>	<u>with</u>
M8 x 1	15.9	<u>2 D</u>	<u>with</u>	<u>with</u>

Table 4-11: Thread characteristics for single inserts at external interfaces (intended for unit inserts)

GENERAL DESIGN AND INTERFACE REQUIREMENTS (GDIR)

REFERENCE : H-P-1-ASPI-SP-0027

DATE : 25-Nov-2003

ISSUE : 4.2

PAGE : 52/118

Standard	<u>Thread length (min.) - mm</u>	<u>Bolt clearance (min.) - mm</u>	Helicoil	Locking device
M4	1.5 D	2 D (1)	with	<u>with</u>
M5	1.5 D	2 D	with	<u>with</u>
M6	1.5 D	2 D	with	<u>with</u>
M8 x 1	1.5 D	2 D	with	<u>with</u>

Table 4-13: Thread characteristics for special inserts (e.g. face-to-face inserts) at external interfaces (intended for internal structural inserts)

*

Note : If the Sub-Contractor of the sub-system or of the unit is responsible for the provision of the bolts, inserts and locking device and if it provides the proper justification, then the use of helicoil with locking device can be accepted.

Reference **GDME-485**

Spacecraft equipment fixation points shall be provided with the following positional tolerances, as defined in Table 4-15.

		Shur-lok insert	Face-to-face insert
Reference hole of the equipment in the platform drilling frame	* committing value		
Remaining holes with regard to the equipment reference hole	* committing value		
	* target		

Table 4-15: inserts positional tolerances

*

Reference **GDME-490**

The use of blind rivets, minimum 3 mm diameter shall be allowed for the followed items:

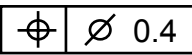
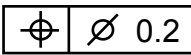
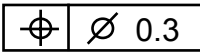
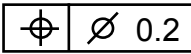
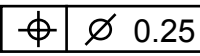
- harness and RF cabling brackets
- pipe brackets.

*

Reference **GDME-500**

The rivets shall be of the set head type. Tools used for riveting shall prevent any damage to structural parts.

*

GENERAL DESIGN AND INTERFACE REQUIREMENTS (GDIR)

REFERENCE : H-P-1-ASPI-SP-0027

DATE : 25-Nov-2003

ISSUE : 4.2

PAGE : 53/118

Reference **GDME-510**

The responsible of structural connection of removable parts (e.g. brackets) shall define:

- screws number
- screws size to be between M4 and M6 (female bi-hexagonal screws)
- type of washers
- torque's to be applied to the screws in accordance with type of inserts, washers and screws
- inserts to be M4, M5 or M6.

*

Reference **GDME-520**

All these fixation hardware definitions have to be approved by the Prime.

*

Reference **GDME-530**

Resistance to vibration will be ensured by effective locking provisions.

*

Reference **GDME-540**

These locking provisions must be capable of being subjected to a minimum of 5 tightening and slackening operations without any significant effect on its bracking power.

*

4.8.5 Baseplate/Surface finish

4.8.5.1 General

Reference **GDME-550**

The contact area between boxes and structure shall be at the area of the lugs. It shall be flat with no protrusion below the mounting plane.

*

Reference **GDME-560**

The contact area or spot faces area shall be unpainted.

*

Reference **GDME-570**

If for thermal reasons larger areas are requested, the contact area (complete bottom face) must meet the following requirements unless there are other mechanical or electrical constraints:

- flatness of 0.1 mm/100 mm (for mounted box and structure in area of mounting plane),
- overall mounting surface flatness < 0.2 mm,

GENERAL DESIGN AND INTERFACE REQUIREMENTS (GDIR)

REFERENCE : H-P-1-ASPI-SP-0027

DATE : 25-Nov-2003

ISSUE : 4.2 PAGE : 54/118

-
- contact surface roughness < 3.2 micrometers (2.5 µm for contact surface w/o thermal interfiller).
-

*

Exceptions are subject to approval by the Prime Contractor.

Reference **GDME-580**

Unit baseplate thickness and dimensions shall be specified on ICD. All mating surfaces between equipment and spacecraft structure shall be left bare.

*

4.8.5.2 Surface finish treatment

No surface treatment is necessary for stainless steel (only passivation), beryllium, silver, fiberglass or carbon fiber, except for the needs of thermal control (if applied to external surfaces) or unless otherwise specified in AD- 4 (EMC/ESD purpose).

Surfaces treatment is necessary for:

- aluminium alloys (except alloys of serie 5000 with magnesium)
- magnesium and its alloys (mandatory).

Surfaces treatment may be necessary for:

- titanium and its alloys
- copper.

Requirements for these treatments are defined in AD- 2. Surface treatment of other materials must be approved by the Prime Contractor.

Cadmium an Tin plating is not acceptable.

4.8.6 Electrical bonding

Reference **GDME-590**

Bonding of units and supports shall be performed according to section 6.2.

*

4.8.7 Grounding

Reference **GDME-600**

It is required to ground all units to the structure according to section 6.2.

*

4.8.8 Damping supports

Reference **GDME-610**

No damping supports external to the unit shall be used.

GENERAL DESIGN AND INTERFACE REQUIREMENTS (GDIR)

REFERENCE : H-P-1-ASPI-SP-0027

DATE : 25-Nov-2003

ISSUE : 4.2 PAGE : 55/118

*

4.9 Verification of the mechanical design

4.9.1 Modelling

Reference **GDME-620**

[P:SCI-PT-RS-05991 - Ch.5#5.7.1.1-SCVE-010 H/P

Any structural Finite Element Model (FEM) shall be delivered in NASTRAN format (SCVE-010).

*

Reference **GDME-630**

A structural Finite Element Model shall be delivered for subsystem and units with a principal mode below 140 Hz. Principal modes are those modes with an effective modal mass > 5%.

*

Reference **GDME-640**

[P:SCI-PT-RS-05991 - Ch.5#5.7.1.1-SCVE-015 H/P

The FEM shall be detailed enough to ensure an appropriate derivation/verification of the design loads and the modal response for all important modes with an effective mass > 5 % of the total mass up to 140 Hz (SCVE-015).

*

Reference **GDME-650**

[P:SCI-PT-RS-05991 - Ch.5#5.7.1.1-SCVE-020 H/P

It shall be supported by additional and more detailed models for the analysis and design of specific aspects (strength verification, thermal stress analysis, thermo-elastic analysis, interface stiffness analysis, optical analysis, as required) (SCVE-020).

*

Reference **GDME-660**

[P:SCI-PT-RS-05991 - Ch.5#5.7.1.1-SCVE-025 H/P

At system level, the FEM shall be reduced to an Interface FEM (IFEM) for the Launcher Coupled Dynamic Analysis (LCDA). The IFEM shall fulfill the requirements established by the Launch Vehicle Authorities as defined in AD- 15 (SCVE-025).

*

Reference **GDME-670**

[P:SCI-PT-RS-05991 - Ch.5#5.7.1.1-SCVE-030 H/P

The FEM's shall be correlated against the results of the modal survey tests carried out at component, subassembly and complete spacecraft level. As a result of that, the following criteria shall be satisfied:

- for the modes with an effective mass greater than 10% of the total mass:

GENERAL DESIGN AND INTERFACE REQUIREMENTS (GDIR)

REFERENCE : H-P-1-ASPI-SP-0027

DATE : 25-Nov-2003

ISSUE : 4.2

PAGE : 56/118

- frequency deviation less than 3%,
 - error for damping factor less than 20%,
 - Modal Assurance Criterium (MAC) greater than 0.9.
- for the modes with an effective mass greater than 5% of the total mass and an eigenfrequency below 100 Hz:
- eigenfrequency deviation less than 5%,
 - MAC greater than 0.9.

(SCVE-030)

*

4.9.2 Analyses

Reference **GDME-680**

[P:SCI-PT-RS-05991 - Ch.5#5.7.1.2-SCVE-035 H/P

All the design loads applicable to the various parts, subassemblies or complete spacecraft shall be substantiated by analyses of significant events during the complete lifetime. They shall be reassessed after each test at subassembly or system level. (SCVE-035)

*

Reference **GDME-690**

[P:SCI-PT-RS-05991 - Ch.5#5.7.1.2-SCVE-040 H/P

The stiffness analysis shall demonstrate compliance with the requirements as indicated in section 4.6.2. The analytically predicted frequencies shall be higher than the minimum requirement specifications with positive margins. (SCVE-040)

*

Reference **GDME-700**

[P:SCI-PT-RS-05991 - Ch.5#5.7.1.2.1-SCVE-050 H/P

[P:SCI-PT-RS-05991 - Ch.5#5.7.1.2.1-SCVE-045 H/P

[P:SCI-PT-RS-05991 - Ch.5#5.6.1.2-SCMD-020 H/P

The stress analysis shall demonstrate positive MOS and cover loads originating from mechanical, thermal and moisture desorption effects combined adequately together. In case of a proto-flight approach, the yield and ultimate MOS shall be greater than 0.2. (SCVE-045, SCVE-050, SCMD-020)

*

Reference **GDME-710**

[P:SCI-PT-RS-05991 - Ch.5#5.7.1.2.1-SCVE-055 H/P

Strength values for mechanical parts shall not be assumed higher than the values specified for the relevant qualification and acceptance tests. (SCVE-055)

*

GENERAL DESIGN AND INTERFACE REQUIREMENTS (GDIR)

REFERENCE : H-P-1-ASPI-SP-0027

DATE : 25-Nov-2003

ISSUE : 4.2 PAGE : 57/118

Reference **GDME-720**

[P:SCI-PT-RS-05991 - Ch.5#5.7.1.2.1-SCVE-060 H/P

Fatigue analysis shall be carried out where relevant, and demonstrate a positive reserve after application of 4 times the most constraining life cycles. (SCVE-060)

*

Reference **GDME-730**

[P:SCI-PT-RS-05991 - Ch.5#5.7.1.2.1-SCVE-065 H/P

Fracture mechanics analysis shall be carried out for the items which are potentially hazardous for the ground operations and meet the requirements specified in AD- 26. (SCVE-065)

*

4.9.3 Testing

Reference **GDME-740**

[P:SCI-PT-RS-05991 - Ch.5#5.7.1.3-SCVE-070 H/P

Verification of the mechanical performance shall be possible by test at element, subassembly or system level (SCVE-070)

*

Reference **GDME-750**

[P:SCI-PT-RS-05991 - Ch.5#5.7.1.3-SCVE-075 H/P

At system level static tests (including the primary structure and high loaded interface structures), the following test factors shall be used with respect to the maximum expected Limit Loads, unless otherwise specified:

- 1.25 for qualification
- 1 for acceptance

(SCVE-075)

*

Reference **GDME-760**

[P:SCI-PT-RS-05991 - Ch.5#5.7.1.3-SCVE-090 H/P

A significant number of standard potted inserts with low margin of safety (MOS) shall be tested for workmanship. (SCVE-090)

*

5. THERMAL DESIGN AND INTERFACE REQUIREMENTS

5.1 General

5.1.1 General requirements

Reference **GDTH-010**

[P:SCI-PT-RS-05991 - Ch.5#5.5.2-SENV-035 H/P

The spacecraft shall be designed to withstand all thermal environments encountered during its entire life, including:

- Integration, transportation and testing, including bake-out
- Spacecraft preparation at the launch site
- Pre-launch phase with the spacecraft under the fairing
- Ascent phase including the coast phase
- In-orbit operations from launcher separation until the end of the mission

(SENV-035)

*

Reference **GDTH-020**

In order to ensure compatibility of equipment designs with the Herschel/Planck thermal control, each equipment shall be designed according to the following requirements:

- To comply with operating, non-operating, minimum switch-on/off and qualification level temperatures, as specified in § 5.1.2.
 - To comply with requirements specified in section 5.3.
 - To withstand the thermal environment as specified in AD- 1.
 - To withstand the unit qualification tests.
 - To comply with any special requirements identified in the applicable subsystem or equipment specifications.
-

*

5.1.2 Equipment Temperature limits

Reference **GDTH-030**

The thermal design of satellite and equipment shall comply with temperature limits and temperature margins as defined hereafter.

*

The required values for operating, non-operating, switch-on and storage temperature limits are indicated in AD- 1.

GENERAL DESIGN AND INTERFACE REQUIREMENTS (GDIR)

REFERENCE : H-P-1-ASPI-SP-0027

DATE : 25-Nov-2003

ISSUE : 4.2

PAGE : 59/118

Reference **GDIR-040 b**

[P:SCI-PT-RS-05991 - Ch.5#5.6.3.3-STHE-098 H/P

[P:SCI-PT-RS-05991 - Ch.5#5.6.3.3-STHE-100 H/P

Temperature ranges definition (see Figure 5-1).

Calculated temperature limits

The calculated temperature limits of a unit are the extreme temperatures, temperature gradients and transients that can be expected during the various mission phases

These temperatures are calculated for all mission phases by a Thermal Mathematical Model (TMM). These calculations include the effects of extreme case combination w.r.t. environmental and operating mode conditions (BOL/EOL conditions, unit dissipations, voltage of power available for heaters...). These worst case conditions will be determined and justified by the thermal control responsible.

Predicted temperature limits

The predicted temperature limits of a unit are equal to the calculated temperature extended at both ends of the range by an appropriate uncertainty margin (U.M.). These predicted temperatures shall remain within the specified design temperature limits.

This margin represents the temperature uncertainty resulting from uncertainties in thermal mathematical modelling, thermal parameters or tolerances and shall be estimated by performing a sensitivity analysis.

Design temperature limits

The design temperature limits of a unit are the extreme temperatures, temperature gradients and transients that the unit shall tolerate during its specified lifetime for the various modes (operational, non-operational, switch-on). This temperature range represents the requirements for the unit internal thermal activities.

Acceptance temperature limits

The operating and non-operating acceptance temperature limits of a unit are equal to the design temperatures limits over the lifetime extended at both ends of the range by the Acceptance Margin (A.M.) of 5°C.

Qualification temperature limits

The operating and non-operating qualification temperature limits of a unit are equal to the design temperatures limits over the lifetime extended at both ends of the range by the Qualification Margin (Q.M.) of 10°C.

Switch-on temperature limit

The switch-on temperature limit is the lowest temperature at which an equipment may have power applied to it, or be activated. The thermal design of the equipment shall be such that upon such power application or activation, the equipment temperature soon moves into the operating temperature limit range

Switch-on qualification temperature

The switch on qualification temperature is the lowest temperature at which an equipment may have power applied to it, or be activated during thermal qualification test.

GENERAL DESIGN AND INTERFACE REQUIREMENTS (GDIR)

REFERENCE : H-P-1-ASPI-SP-0027

DATE : 25-Nov-2003

ISSUE : 4.2

PAGE : 60/118

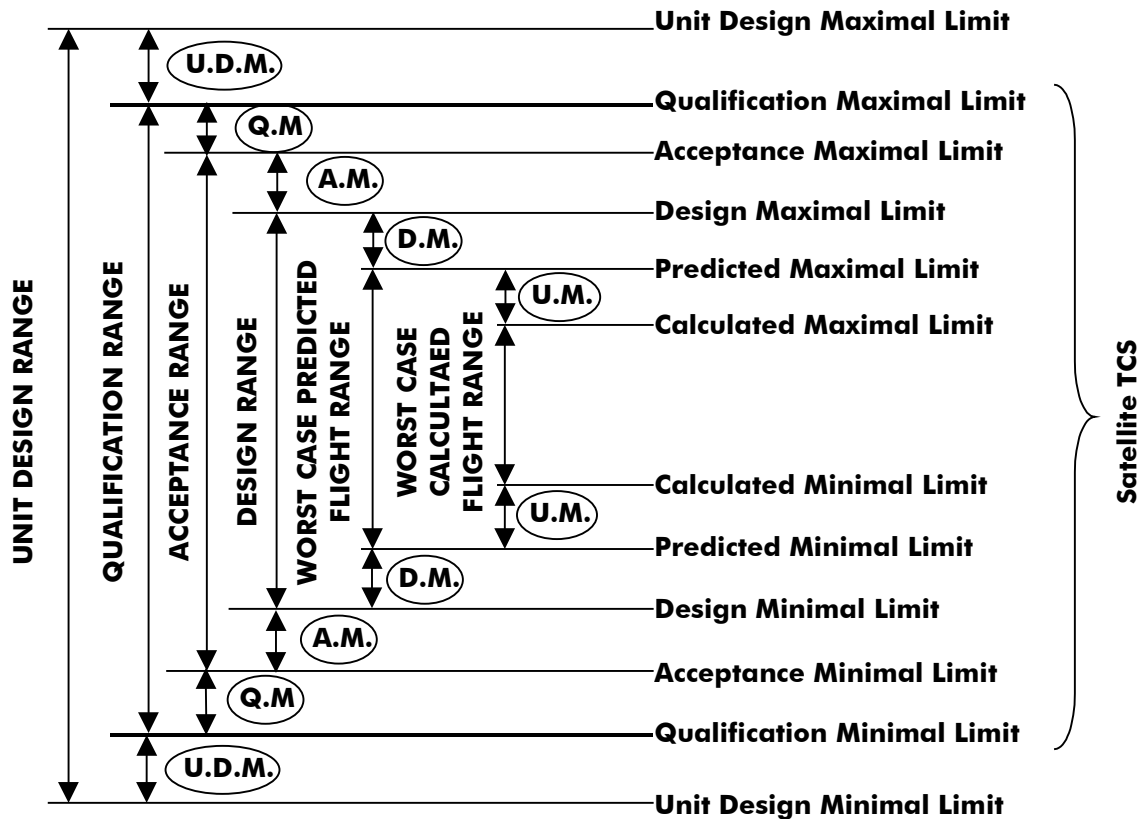

Notes:

- U.M.= Modelling Uncertainty Margin
- D.M.= Thermal Control Design Margin / ABS (D.M.) > 0 °C
- A.M.= Acceptance Margin / A.M. = 5 °C
- Q.M.= Qualification Margin / Q.M. = 5 °C
- U.D.M.= Unit Design Margin / U.D.M > 0°C

with

- U.M. + D.M. = 9°C, except for Herschel HIFI HRV (11°C) and Planck Sorption Cooler units (7°C).

Figure 5-1: Temperature limits definition

*

Reference **GDTH-042 a**

A margin on Power shall be included in the calculated limits, according to AD-35 (instrument warm units excepted).

*

The various definitions defined above and the related margin philosophy are valid for conventional temperature range.

Reference **GDTH-050**

[P:SCI-PT-RS-05991 - Ch.5#5.6.3.1-STHE-050 H/P

GENERAL DESIGN AND INTERFACE REQUIREMENTS (GDIR)

REFERENCE : H-P-1-ASPI-SP-0027

DATE : 25-Nov-2003

ISSUE : 4.2 PAGE : 61/118

For Cryogenic temperatures, the unit temperature ranges shall be tailored to the relevant cryogenic range. The proposed ranges shall be subject to ESA approval. (STHE-050)

*

5.1.3 Temperature reference points

Reference **GDTH-060**

All temperature requirements of units shall refer to specific points of these units. The location of these reference points shall be defined by the unit Contractor such that their temperatures can be related to the general thermal status of the unit and the critical unit components.

*

Reference **GDTH-070**

Preferably one of the unit reference points shall be located on the baseplate close to unit fixation points.

*

The number of these reference points has to be minimised.

5.2 Satellite thermal design

5.2.1 General

Reference **GDTH-080**

[P:SCI-PT-RS-05991 - Ch.5#5.6.3.3-STHE-080 H/P

The TCS shall ensure that all equipment temperatures remain within the thermal design limits defined for each unit, during all phase of the mission, including ground testing. If applicable, it shall also ensure the required temperature stability for equipment. It shall maintain the structural parts within the required temperatures and temperature stabilities such that the necessary alignments are met between units involved in the pointing or alignment required performances. (STHE-080)

*

Reference **GDTH-090**

[P:SCI-PT-RS-05991 - Ch.5#5.6.3.3-STHE-075 P

[P:SCI-PT-RS-05991 - Ch.5#5.6.3.3-STHE-070 H

The thermal design shall comply with the requirements of the Herschel and Planck IID's part B (STHE-075). In particular, for the Herschel cryogenic subsystem, all thermal requirements as specified in IID's Part B for the Focal Plane units and any other payload or spacecraft unit requiring cryogenic cooling for at least the nominal lifetime until all helium has been consumed shall be met (STHE-070).

*

Note: The values (temperature and power) given in the IIDA for the Focal Plane Unit of Herschel form an overall envelope.

Reference **GDTH-100 a**

[P:SCI-PT-RS-05991 - Ch.5#5.6.3.4-STHE-105 H/P

GENERAL DESIGN AND INTERFACE REQUIREMENTS (GDIR)

REFERENCE : H-P-1-ASPI-SP-0027

DATE : 25-Nov-2003

ISSUE : 4.2 PAGE : 62/118

The Herschel and Planck thermal design shall be as simple as possible. MLI and radiators with thermal coatings control the Sun, Earth and albedo effects and the internal heat distribution and rejection. Internally, thermal coatings and conductive paths will be used to control the temperature of critical units.

*

Reference **GDTH-101**

[P:SCI-PT-RS-05991 - Ch.5#5.6.3.3-STHE-085 H/P

The Herschel and Planck thermal design shall be compatible with all solar aspect angles and albedo and any radiated inputs which are foreseen during all mission phases.

*

Reference **GDTH-102**

[P:SCI-PT-RS-05991 - Ch.5#5.6.3.4-STHE-110 H/P

The Herschel and Planck thermal design shall use heaters when necessary. All heaters shall be capable of being commanded from ground.

*

Reference **GDTH-103**

[P:SCI-PT-RS-05991 - Ch.5#5.6.3.4-STHE-140 H/P

Grouping of heaters circuit shall be implemented whenever feasible in order to minimise the total number of needed ON-OFF commands.

*

Reference **GDTH-104**

[P:SCI-PT-RS-05991 - Ch.5#5.6.3.4-STHE-135 H/P

The Herschel and Planck thermal design shall achieve modularity between SVM and PLM thermal control. It shall be possible to develop, integrate and test the spacecraft at module level with minimum interaction from the other modules. The modules shall therefore be thermally de-coupled as much as possible.

*

Reference **GDTH-106**

[P:SCI-PT-RS-05991 - Ch.5#5.6.3.2-STHE-060 H/P

The Herschel and Planck thermal design shall be simple by using the inherent or designed-in thermal properties of structure and units, a minimum of additional thermal control components and the satellite geometry to maintain temperature levels and distributions within the specified limits for allowable satellite orientations.

*

Reference **GDTH-107**

The Herschel and Planck thermal design shall :

- use proven components and techniques.
- be designed in order to minimise the uncertainties (i.e. the sensitivity to the design parameters). It shall permit reliable mathematical modelling of external and internal features.

GENERAL DESIGN AND INTERFACE REQUIREMENTS (GDIR)

REFERENCE : H-P-1-ASPI-SP-0027

DATE : 25-Nov-2003

ISSUE : 4.2

PAGE : 63/118

- optimise the heating and mass budgets.
- be independent from subsystems and equipment.

*

Reference **GDTH-108**

[P:SCI-PT-RS-05991 - Ch.5#5.6.3.2-STHE-065 H/P

The Herschel and Planck thermal design shall include sufficient thermal sensors for in-flight monitoring of equipment temperatures. These sensors shall provide information about spacecraft health and shall serve as reference for heater control.

*

Reference **GDTH-110**

[P:SCI-PT-RS-05991 - Ch.5#5.6.3.3-STHE-095 H/P

The thermal control shall be such designed to:

- accommodate variations of units dissipation, as defined in the ICD
- accommodate variations of coatings thermal properties (α , ϵ), due to thermal surface degradation resulting from exposure to environments (STHE-095). Protective covers, cleaning procedures and surface property measurements will be employed to insure that external coatings properties will be optimum at launch.

*

Reference **GDTH-130**

[P:SCI-PT-RS-05991 - Ch.5#5.6.3.4-STHE-120 H/P

The thermal control subsystem design shall incorporate sufficient flexibility to accommodate foreseeable changes in lay-out, power dissipation (amount and location), mission requirements and required temperature ranges. (STHE-120)

*

Reference **GDTH-140**

[P:SCI-PT-RS-05991 - Ch.5#5.6.3.4-STHE-125 H/P

The thermal design shall be such that easy repair and minor changes in design are possible through simple removal and replacement of insulation blankets, foils, heaters and/or by in-place refurbishment of thermal control coatings and surface treatments. (STHE-125)

*

Reference **GDTH-150**

[P:SCI-PT-RS-05991 - Ch.5#5.6.3.4-STHE-130 H/P

The thermal design shall minimise the need for ground operational testing and subsystem level thermal vacuum tests. It shall not impose unacceptable constraints on other spacecraft elements nor on mission operation (STHE-130)

*

GENERAL DESIGN AND INTERFACE REQUIREMENTS (GDIR)

REFERENCE : H-P-1-ASPI-SP-0027

DATE : 25-Nov-2003

ISSUE : 4.2

PAGE : 64/118

Reference **GDTH-160**

All Herschel and Planck thermal and geometrical mathematical models shall be established and delivered to Prime Contractor and/or ESA according to requirements defined in AD- 9.

*

Reference **GDTH-170**

At the start of the design and analysis process, design margins shall be established to cover modelling and hardware uncertainties and to indicate the sensitivity of the design to variations of various parameters.

*

5.2.2 Material and components

Reference **GDTH-180**

As far as possible, materials will be chosen in order to limit stresses induced by thermal cycling i.e. with a low thermal expansion coefficient.

*

Reference **GDTH-190**

Couple of materials will be chosen to decrease differential thermal deformation i.e. with thermal expansion coefficients of the same order of magnitude.

*

Reference **GDTH-210**

Use of OAC (Chromic Anodised Oxidation) or OAS (Sulphuric Anodised Oxidation) protective coatings on external surfaces shall be approved by the Prime Contractor.

*

Reference **GDTH-220**

Paints and coatings must satisfy outgasing criteria, optical requirements and resistance to thermal cycling requirement and environment (UV...).

*

Note : ASP recommends that all external Kapton foils of ITO MLI, if any, have a thickness of 50 μm .

Reference **GDTH-250**

MLI's efficiency shall be guaranteed at $\pm 50\%$ at conventional temperature range (AD- 35). This figure is to be determined by analysis on a case by case basis for cryogenic temperature range.

*

Reference **GDTH-260 a**

Edge of Honeycomb panels shall be covered by Kapton foils, except for Planck solar array panels.

*

GENERAL DESIGN AND INTERFACE REQUIREMENTS (GDIR)

REFERENCE : H-P-1-ASPI-SP-0027

DATE : 25-Nov-2003

ISSUE : 4.2 PAGE : 65/118

Reference **GDTH-270**

Thermophysical properties of any interface filler material or of any adhesive tape or similar materials shall be or shall have been determined and/or verified experimentally.

*

Reference **GDTH-280**

Thermal elements for which dismountability is required during integration and verification shall be removable without degradation of their thermal characteristics.

*

Reference **GDTH-290**

The method of application of any thermal coating shall be such that, in event of damage occurring to any thermal surface, the rework/repair shall be capable of being performed outside equipment manufacturer premises (rework/repair carried out in Prime Contractor premises or on launch pad).

*

5.3 Equipment thermal design

5.3.1 General requirements

Reference **GDTH-300**

Each unit shall be designed so that all internal heat sources have the required insulation or heat flow to the external surfaces of the unit, when the average temperature of these surfaces is within the applicable acceptance or qualification temperature range defined in the relevant unit specification.

*

Reference **GDTH-310**

In designing the unit and ascertaining the optimum heat flow paths, the equipment Contractor shall take into account the mounting method and the exchanges with the environment by both conduction convection and radiation.

*

Reference **GDTH-320**

The Unit Contractor shall carry out a thermal analysis of the unit internal temperature distribution and hot points in sufficient detail to demonstrate that temperature requirements for all thermally critical components are met even under single failure conditions.

*

5.3.2 Design requirements

Reference **GDTH-330**

To give maximum flexibility in location and application of each unit the equipment shall be designed for the worst most general, environments i.e. that given is AD- 1.

GENERAL DESIGN AND INTERFACE REQUIREMENTS (GDIR)

REFERENCE : H-P-1-ASPI-SP-0027

DATE : 25-Nov-2003

ISSUE : 4.2

PAGE : 66/118

*

Reference **GDTH-340**

Geometrical, thermo-optical and thermal properties, contact area, dissipated power for various modes and qualification temperature range shall be defined in IDS and/or ICD.

*

Reference **GDTH-350**

The location of the Reference Temperature points where thermocouples and thermistances are mounted shall be indicated on the ICD. One of this point shall be located on the baseplate close to a fixation point; when not indicated, the Reference Hole shall be the Reference Temperature point.

*

Reference **GDTH-360**

The thermo-optical characteristic of the units shall be defined by the thermal control subsystem. Unit supplier is responsible for the application of a coating compliant with thermal requirements. Effect of age and radiation shall be taken into account to estimate thermo-optical characteristics.

*

Reference **GDTH-380**

As a general requirement any thermo-optical and thermal properties defined in IDS and/or ICD shall be demonstrated by thermo-optical coating manufacturer data and process qualification report or measurement on sample or measurement on the equipment itself. Justification of the specified values shall be supplied to the Prime Contractor on request.

*

Reference **GDTH-390 a**

Deleted.

*

Reference **GDTH-400**

Special care must be taken for low thermal conductivity elements with high temperature gradient ($> 100^{\circ}\text{C}$) for which estimate of radiative and conductive heat transfer shall be justified by measurement. MLI efficiency and conductance values shall be justified and agreed by the Prime Contractor.

*

Reference **GDTH-410**

Concerning unit fixation, all units working in the 0°C - 80°C temperature range with a skin radiated power larger than 65 W/m^2 (or 50 W/m^2 when the maximal operational temperature is inferior or equal to 45°C) shall have a flat baseplate contact with support structure. All other units shall comply with the requirements included in § 4.8.

*

5.4 Verification of thermal design

Unit thermal control is under their manufacturer's responsibility. Analysis of units thermal control shall be conducted using mathematical models.

5.4.1 Modelling

Reference **GDTH-420**

[P:SCI-PT-RS-05991 - Ch.5#5.7.3.1-SCVE-100 H/P

Detailed Thermal Mathematical Models (DTMM) and Detailed Geometrical Mathematical Models (DGMM) of the spacecraft shall be created for analytical predictions representative of all the phases of the mission, including ground tests. (SCVE-100)

*

Note : Parametrical modelling approach is recommended to ease follow up of design definition.

Reference **GDTH-430**

[P:SCI-PT-RS-05991 - Ch.5#5.7.3.1-SCVE-105 H/P

The models shall unambiguously identify the flight and the test monitoring points (SCVE-105)

*

Reference **GDTH-440**

[P:SCI-PT-RS-05991 - Ch.5#5.7.3.1-SCVE-110 H/P

The Detailed Thermal Mathematical Models (DTMM) shall be delivered as a coherent set of ESATAN files (compatible with version 8.5 or higher), and together with any script necessary to run the models and analysis cases. Sub-modelling techniques shall be used down to a level agreed with the Agency (SCVE-110)

*

Reference **GDTH-450**

[P:SCI-PT-RS-05991 - Ch.5#5.7.3.1-SCVE-115 H/P

The Detailed Geometrical Mathematical Model (DGMM) shall be delivered as a coherent set of ESARAD files (compatible with version 4.3.2 or higher), and together with any script necessary to run the models and analysis cases. The set of ESARAD files shall include as a minimum the geometry definition, the kernel files and the ESATAN formatting files. (SCVE-115)

*

Reference **GDTH-460**

[P:SCI-PT-RS-05991 - Ch.5#5.7.3.1-SCVE-120 H/P

The detailed DTMM and DGMM shall be correlated against the environmental test results. After correlation, the temperature differences between predictions and measurements shall be analysed for all the measurement points. (SCVE-120)

*

GENERAL DESIGN AND INTERFACE REQUIREMENTS (GDIR)

REFERENCE : H-P-1-ASPI-SP-0027

DATE : 25-Nov-2003

ISSUE : 4.2

PAGE : 68/118

5.4.2 Analysis

Reference **GDTH-470**

[P:SCI-PT-RS-05991 - Ch.5#5.7.3.2-SCVE-140 H/P

The compliance with the thermal performance requirements shall be demonstrated by analysis for the nominal operational and non-operational cases. (SCVE-140)

*

Reference **GDTH-500**

[P:SCI-PT-RS-05991 - Ch.5#5.7.3.2-SCVE-155 H/P

The differences between the test measurements and the test simulated by the correlated DTMM shall be taken into account for the final flight predictions. (SCVE-155)

*

5.4.3 Testing

Reference **GDTH-520**

[P:SCI-PT-RS-05991 - Ch.5#5.7.3.3-SCVE-175 H/P

The thermal design of the spacecraft shall be validated by a thermal balance test (SCVE-175)

*

Reference **GDTH-530**

[P:SCI-PT-RS-05991 - Ch.5#5.7.3.3-SCVE-180 H/P

The test cases shall cover, as far as practical, the extreme environmental conditions envisaged for the complete mission and the most critical predicted thermal situations (SCVE-180)

*

Reference **GDTH-540**

[P:SCI-PT-RS-05991 - Ch.5#5.7.3.3-SCVE-185 H/P

The spacecraft thermal sensors (e.g. thermistors, thermo-couples) shall be continuously monitored during the test and be used for the assessment of the stabilisation. In addition, they shall be used for the correlation. Additional measurement points shall be provided by test thermal sensors, mainly for complementing the flight measurement plan and monitoring local or general environmental data. (SCVE-185)

*

Reference **GDTH-550**

[P:SCI-PT-RS-05991 - Ch.5#5.7.3.3-SCVE-190 H/P

The environment induced by the test facility shall be continuously monitored during the test with the level of detail, as it will be required by the thermal mathematical model for the prediction of the test. (SCVE-190)

*

GENERAL DESIGN AND INTERFACE REQUIREMENTS (GDIR)

REFERENCE : H-P-1-ASPI-SP-0027

DATE : 25-Nov-2003

ISSUE : 4.2 PAGE : 69/118

6. ELECTRICAL DESIGN AND INTERFACE REQUIREMENTS

6.1 General

Reference **GDEL-010**

The electrical compatibility of equipment/subsystem shall be ensured: the equipment/subsystem shall be able to operate without degradation of performance in all specific ground and flight environments, both independently and together.

*

6.2 Grounding bonding and isolation

6.2.1 General

The general objective of electrical grounding is to produce an equipotential surface, through the reduction of potentials acquired from the ambient plasma and currents flowing in the structure. Proper Satellites System electrical grounding requires attention to structure grounding (electrical bonding) and circuit grounding.

Reference **GDEL-015**

Practices for grounding and bonding of devices, cables, equipment and systems shall incorporate the following:

- Prevention of hazards in the events of an equipment frame developing a high potential from internal equipment faults or from induced fields
- Prevention of build-up of static electricity
- Reduction of electromagnetic interference due to electric field or other forms of mutual coupling
- Protection of the Spacecraft System from hazards associated with lightning discharges and induced effects from lightning
- Provision of an equipotential surface to serve as a zero signal reference plane for electrical/electronic system.

*

Reference **GDEL-025**

An overall zero volt and grounding diagram shall be provided in the IDS/ICD for establishing functional and electromagnetic compatibility. This diagram shall indicate any AC or DC loop, the type of isolation/insulation used, any impedance coupling between zero volt and structure, and the type of connection between secondary 0 V and mechanical ground (if any).

*

Reference **GDEL-027**

[P:SCI-PT-RS-05991 - Ch.5#5.5.6-SENV-175 H/P

The grounding scheme shall be selected to meet the payload and spacecraft subsystem requirements. As baselined, the spacecraft will adopt a distributed single point grounding scheme. (SENV-175)

GENERAL DESIGN AND INTERFACE REQUIREMENTS (GDIR)

REFERENCE : H-P-1-ASPI-SP-0027

DATE : 25-Nov-2003

ISSUE : 4.2 PAGE : 70/118

*

Reference **GDEL-030**

The Equipment Supplier and/or Subsystem Supplier shall provide a grounding diagram (symbols described in Figure 6-1 shall be used to draw it).

GENERAL DESIGN AND INTERFACE REQUIREMENTS (GDIR)

REFERENCE : H-P-1-ASPI-SP-0027

DATE : 25-Nov-2003

ISSUE : 4.2

PAGE : 71/118

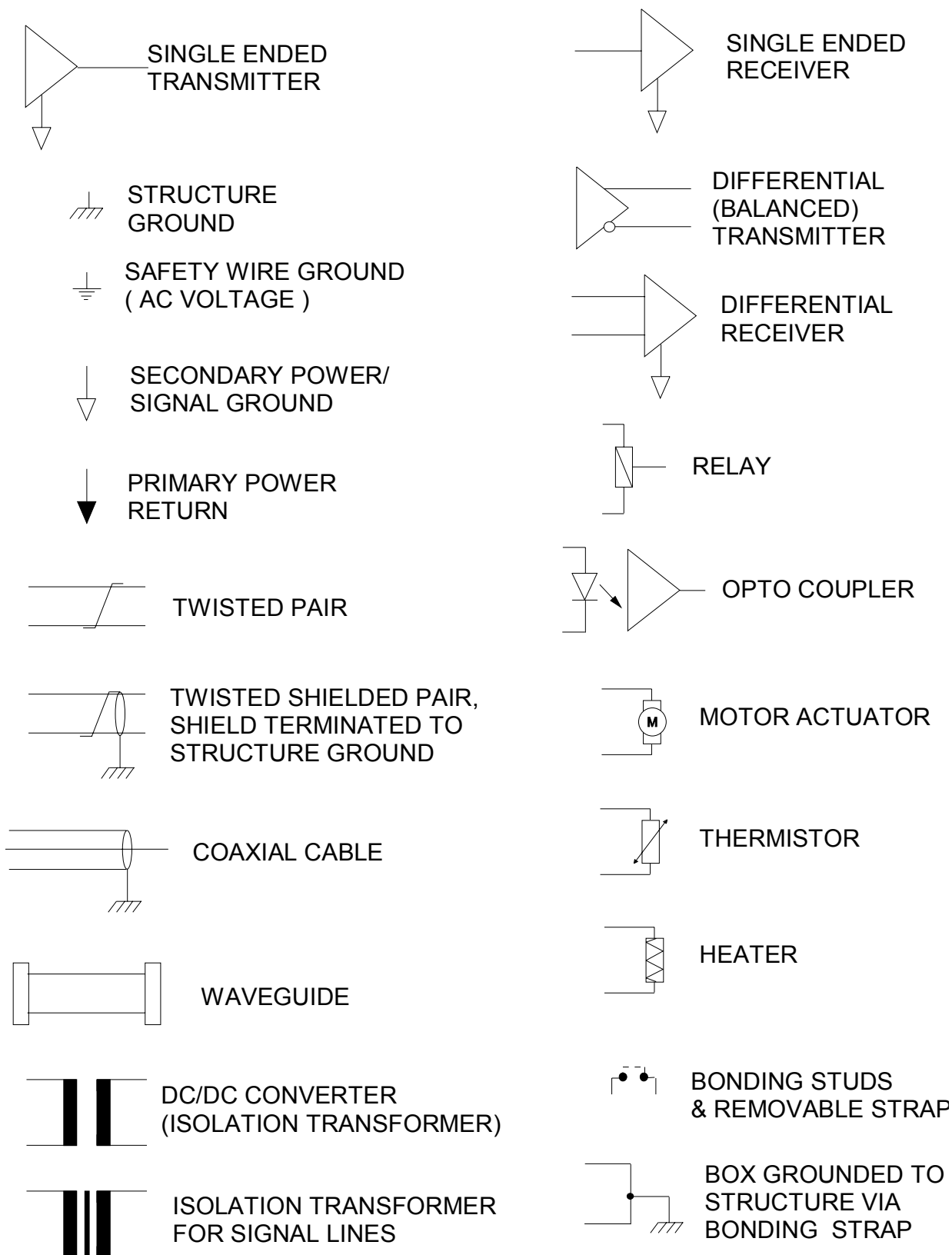

Figure 6-1: Symbols for Grounding Diagrams

*

GENERAL DESIGN AND INTERFACE REQUIREMENTS (GDIR)

REFERENCE : H-P-1-ASPI-SP-0027

DATE : 25-Nov-2003

ISSUE : 4.2

PAGE : 72/118

6.2.2 Structural grounding and bonding

6.2.2.1 Bonding

6.2.2.1.1 Bonding requirements

Reference **GDEL-035**

[P:SCI-PT-RS-05991 - Ch.5#5.5.6-SENV-180 H/P

To provide electrical continuity throughout the Satellites structure, electronic frames and other conductive parts, adequate bonding (electrical conductivity) shall be realized. (SENV-180)

*

Reference **GDEL-040**

All electrically conductive components of the structure including all metallic or carbon fiber items shall be electrically connected.

*

Reference **GDEL-045**

The bonding resistance between any adjacent metallic structure parts shall be lower than 5 mΩ.

*

Reference **GDEL-047**

Carbon fibre structural parts shall not be used as bonding paths.

*

Reference **GDEL-048 a**

If used, grounding rails shall be implemented in the form of semi-rigid foil strips attached to the non-metallic structural elements. These grounding rails shall :

- be routed as close as possible to each unit mounted on the non-metallic structure ;
- follow the harness routing ;
- have a minimum 3 cm width.

*

Reference **GDEL-050**

The bonding resistance between conductive non metallic parts and the metallic structure (electrical reference) of the Spacecraft shall the lower than 100 kΩ.

*

Refer to Figure 6-5 for preferred bonding methods.

GENERAL DESIGN AND INTERFACE REQUIREMENTS (GDIR)

REFERENCE : H-P-1-ASPI-SP-0027

DATE : 25-Nov-2003

ISSUE : 4.2

PAGE : 73/118

Reference **GDEL-055**

The bonding of an equipment shall provide a low and stable impedance path between two metallic parts by the use of a bond strap as detailed hereafter, in addition to the direct contact.

*

Reference **GDEL-060**

Requirements for bond strap:

- Bonds shall be as direct and short as possible (different length can be used to cope with all situation, maintaining length to width ratio lower or equal to 5:1. The minimal width to be used is 8 mm with)
- Each bond shall have a resistance ≤ 2.5 mOhms
- Bonds shall be adequate in cross-sectional areas to carry fault currents where applicable, without fusing, burning or arcing (150 % of circuit protection device rating) with a temperature limit of 50°C max for an indefinite time
- Each bond shall be sufficiently robust to withstand vibration, expansion, contraction or relative movement of parts incident to normal service without breaking or loosening the bond or causing a change in contact resistance
- Weakening of vital structures shall not occur as a result of bond application
- Self-tapping screws shall not be used for bonding purposes.
- Bonding connections shall be installed in such a manner as not to interfere in any way with the operation of movable components
- Bonding of tubular members or conduits, if not inherently bonded shall be achieved by means of a plain metallic clamp and jumper without crimping or damaging the member
- Outer and inner metallized layers of thermal insulation shall both be bonded to the structure (ref. section 6.2.2.2)
- Where dissimilar metals are to be bonded, the elements of the bonding connections shall be selected to minimize the possibility of corrosion, and to assure that if corrosion occurred, it would be in replaceable elements, such as washers, jumpers or separators, rather than in the system basic structure.

GENERAL DESIGN AND INTERFACE REQUIREMENTS (GDIR)

REFERENCE : H-P-1-ASPI-SP-0027

DATE : 25-Nov-2003

ISSUE : 4.2

PAGE : 74/118

Group No.	Metallurgical Category	EMF (Volt)	Anodic Index (0.01V)	Compatible Couples (see note below)
1	Gold, solid and plated; gold platinum alloys; wrought platinum	.+0.15	0	○
2	Rhodium plated on silver-plated copper, graphite	.+0.05	10	○ ↓
3	Silver, solid or plated; high silver alloys	0	15	○ ↓ ●
4	Nickel, solid or plated; monel metal high nickel-copper alloys, titanium	-.0.15	30	○ ↓ ●
5	Copper, solid or plated; low brasses or bronzes; silver solder; German silver; high copper-nickel alloys; nickel-chromium alloys; austenitic corrosion resistant steels	-.0.20	35	○ ↓ ●
6	Commercial yellow brasses and bronzes	-.0.25	40	○ ↓ ●
7	High brasses and bronzes: naval brass; Muntz metal	-.0.30	45	○ ↓ ●
8	18 percent chromium type corrosion-resistant steels	-.0.35	50	○ ↓ ●
9	Chromium, plated; tin, plated; 12 percent chromium type corrosion - resistant steels	-.0.45	60	○ ↓ ●
10	Tin-plate; terneplate, tin-lead solder	-.0.50	65	○ ↓ ●
11	Lead, solid or plated; high lead alloys	-.0.55	70	○ ↓ ●
12	Aluminium, wrought alloys of the duralumin type	-.0.60	75	○ ↓ ●
13	Iron, wrought, gray or malleable; plain carbon and low alloy steels, armco iron	-.0.70	85	○ ↓ ●
14	Aluminium, wrought alloys other than duralumin type; aluminium, cast alloys of the silicon type	-.0.75	90	○ ↓ ●
15	Aluminium, cast alloys other than silicon type; cadmium, plated and chromated	-.0.80	95	○ ↓ ●
16	Hot-dip-zinc plate; galvanized steel	-.1.05	120	○ ↓ ●
17	Zinc, wrought; zinc-base die-casting alloys; zinc, plated	-.1.10	125	○ ↓ ●
18	Magnesium and magnesium-base alloys, cast or wrought	-.1.60	175	●

Note:

- = Indicates the most cathodic members of the series
- = Indicates an anodic member
- Arrows indicate the anodic direction

Figure 6-3: Dissimilar metals EMF compatibility table.

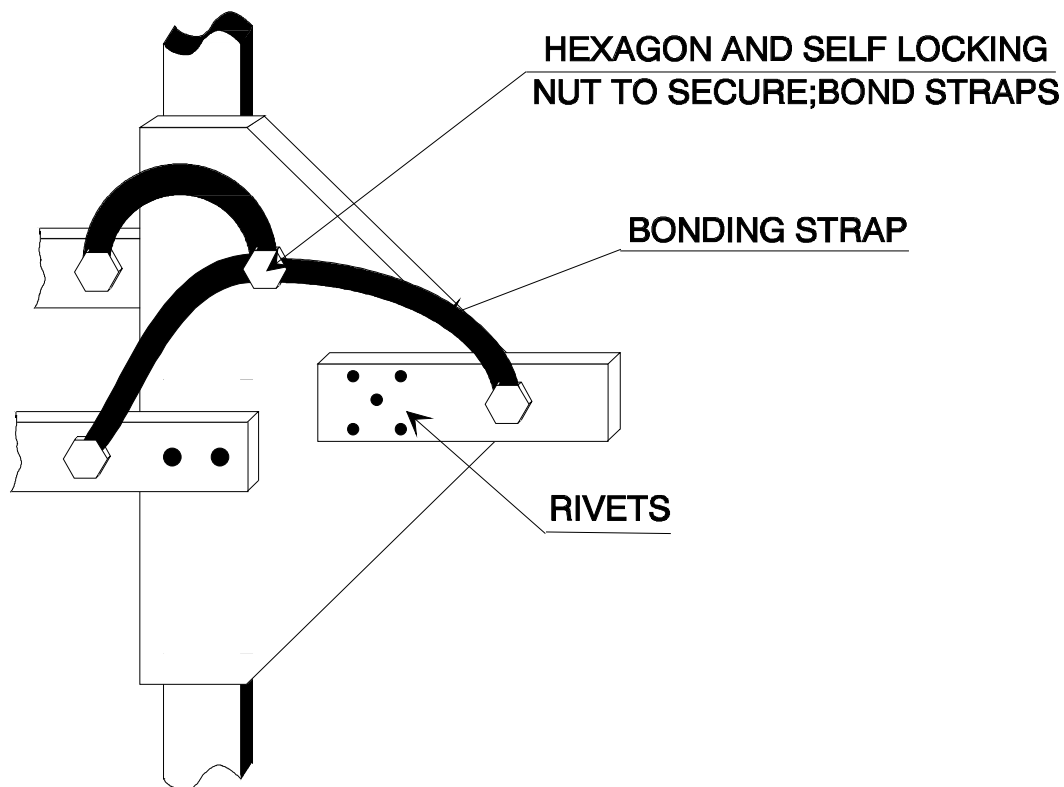

BONDING STRAP ARRANGEMENT

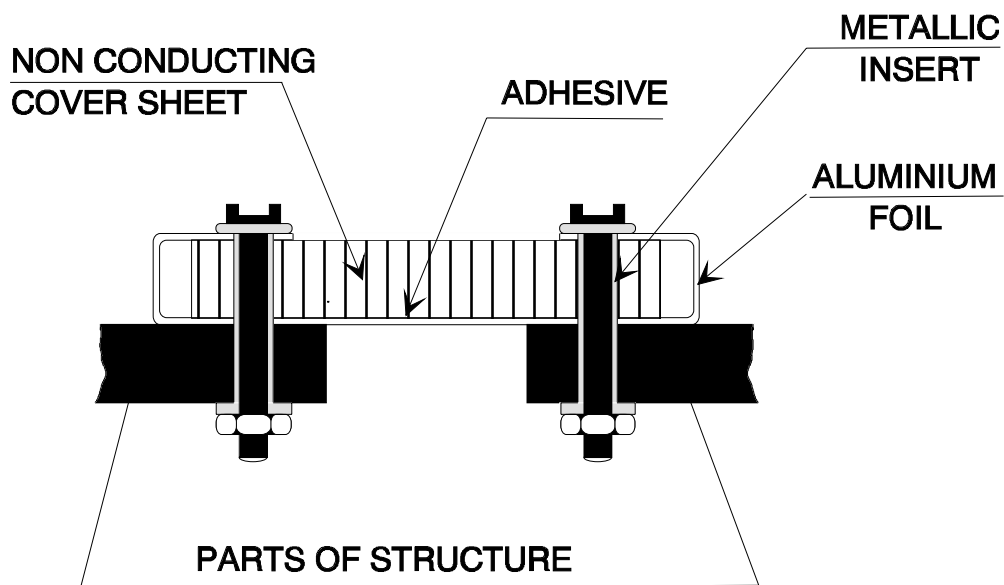

Shielding and bonding of cut-outs is mandatory, if non conductive material is used as a cover.

Figure 6-5: Typical Bonding Methods

GENERAL DESIGN AND INTERFACE REQUIREMENTS (GDIR)

REFERENCE : H-P-1-ASPI-SP-0027

DATE : 25-Nov-2003

ISSUE : 4.2

PAGE : 76/118

6.2.2.1.2 Internal equipment assembly requirements

Reference **GDEL-065**

The equipment chassis material shall be electrically conductive.

*

Reference **GDEL-070**

The electronic equipment boxes shall be fitted with an attachment point for bonding purpose; when defined, that attachment point is called reference bonding point.

*

A bonding strap will connect it to the Satellites structure (as described in previous section)

Reference **GDEL-075**

All part of the unit structure shall be electrically connected.

*

Reference **GDEL-080**

The DC resistance between two points of a metal case shall be less than 5 m Ohm (test at 1 A).

*

This includes the resistance between any point of the case and any point of a cover or connector or bonding point.

6.2.2.1.3 Internal equipment assembly bonding implementation

Reference **GDEL-085**

All metallic subchassis, chassis and enclosures of each unit, including all connector shells and other fittings, shall be bonded.

*

Reference **GDEL-090**

The bonding requirements are such that all equipment primary and secondary structures supporting or containing electrical-electronic assemblies shall be bonded by one of the following methods, in order of preference:

- Direct inherent bond by welding, brazing, soldering, etc.
- Direct semi-permanent bond, where clean metal areas are mated with a fastening method that exerts sufficient pressure to withstand deforming stresses, shocks and vibrations
- Riveting joints where at least three rivets are driven tight per joint
- Clamped metallic fittings, normally permanent and immovable after installation
- Lock-threaded devices (bolts, nuts, studs, lock-washers)
- Indirect bond, bonded to each of the members using a strap of solid flat metal

The use of two or more bonding straps or jumpers in series is not permitted.

GENERAL DESIGN AND INTERFACE REQUIREMENTS (GDIR)

REFERENCE : H-P-1-ASPI-SP-0027

DATE : 25-Nov-2003

ISSUE : 4.2

PAGE : 77/118

*

6.2.2.2 Thermal control parts

Blankets and coatings

Reference **GDEL-095**

Material used as blanketing $\geq 0.5 \text{ cm}^2$ shall be metalized or conductively coated on at least one side of each blanket layer.

*

Reference **GDEL-100**

Use of nonconductive material $\geq 0.5 \text{ cm}^2$ shall be justified.

*

Design requirements to prevent charging and Electrostatic discharging are presented in section 6.3.

Reference **GDEL-105**

There shall be at least one ground point for all layers for every square meter of blanket surface area, and at least two points for each blanket, except that only one point is required for a blanket that is completely covered by other blanketing.

*

Reference **GDEL-110**

Provision of only one grounding point for small pieces (up to some tens of cm^2) shall be subject to the Prime Contractor approval.

*

Reference **GDEL-115 a**

For MLI having one dimension smaller than 50 cm, grounding points shall be provided every 50 cm along the other direction.

*

Reference **GDEL-120**

The DC resistance between one of these points and the structural reference shall be less than 100 m Ohm (test at 1 A).

*

Reference **GDEL-125**

Moreover, each metallized foil shall be electrically connected to the grounding point of the MLI piece.

*

Reference **GDEL-130**

The DC resistance between this point and any point belonging to a metallized face of any foil shall be less than 10 Ohm (test at 100 mA).

GENERAL DESIGN AND INTERFACE REQUIREMENTS (GDIR)

REFERENCE : H-P-1-ASPI-SP-0027

DATE : 25-Nov-2003

ISSUE : 4.2

PAGE : 78/118

*

Reference **GDEL-135**

The edges of the blanket shall be bound with material having a conductive outer side, which is bonded to the blanket ground points.

*

A typical method is presented in Figure 6-7.

Reference **GDEL-140**

Each blanket ground point shall be connected to the nearest practical point on the structure, with a minimum length grounding wire.

*

Reference **GDEL-145**

As a goal, the blanket grounding wire length shall be less than 15 cm.

*

Reference **GDEL-150**

Single layer blanketing external to the bus, e.g., thermal tape applied to cabling, shall be electrically conductive on the outer side.

*

Reference **GDEL-155**

Each metallized face of a thermal shield internal as well as external (e.g. Kapton aluminized in both faces) shall be connected to the structure even if the thermal shield is made by only one foil. Bonding requirements are as for MLI.

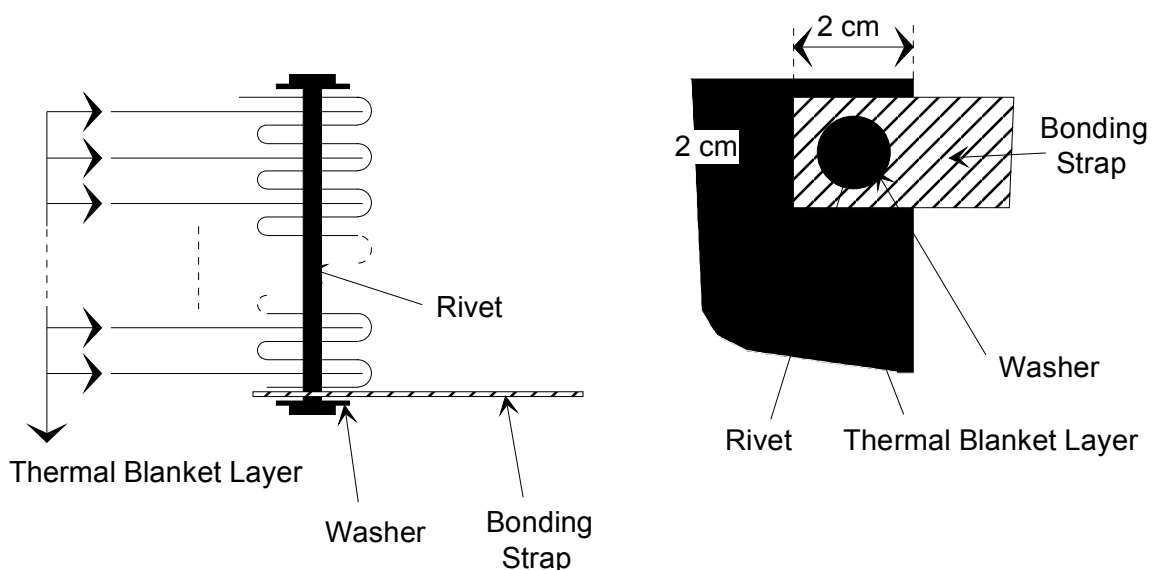

Figure 6-7: Bonding of Thermal Blankets (Guideline)

*

GENERAL DESIGN AND INTERFACE REQUIREMENTS (GDIR)

REFERENCE : H-P-1-ASPI-SP-0027

DATE : 25-Nov-2003

ISSUE : 4.2

PAGE : 79/118

OSR

Reference **GDEL-160**

The conductive part of the OSR shall be electrically connected to the electrical ground reference network by means of conductive glue.

*

Reference **GDEL-165 a**

The DC resistance between the conductive OSR surface and the electrical ground reference network shall be less than 3 k Ω tested at 10 mA;

OR

The DC resistance between the conductive OSR external surface and the electrical ground reference network shall be less than 20 kW tested at 10 mA.

*

Heaters and Thermistors

Reference **GDEL-170**

Heaters and thermistors shall be galvanically isolated from the satellite structure with

- Resistance \geq 10 M Ω
- Capacitance \leq 50 nF

*

6.2.2.3 Exposed conductors

Reference **GDEL-175**

All unmated connectors shall be completely capped with conductive covers prior to launch.

*

Reference **GDEL-185**

No dielectric parts of disconnected electrical conductors shall be exposed to space.

*

6.2.2.4 Conductive element grounding

Reference **GDEL-190**

All radiation shields, circuit traces and conductors with a surface greater than 3 cm² shall be electrically grounded unless it can be demonstrated that their resistance w.r.t. structure is \leq 10 MOhms.

*

Reference **GDEL-195**

Braided overshields with greater than 85 % coverage shall be required on all cabling outside of the spacecraft.

GENERAL DESIGN AND INTERFACE REQUIREMENTS (GDIR)

REFERENCE : H-P-1-ASPI-SP-0027

DATE : 25-Nov-2003

ISSUE : 4.2

PAGE : 80/118

*

Reference **GDEL-200**

Diameter of braid strands shall be 0.1 mm or larger.

*

Reference **GDEL-205**

Each overshield shall be grounded to structure prior to entering the spacecraft or any external, closed Faraday chamber.

*

6.2.2.5 External electronic component

Reference **GDEL-210**

All electronic components external to a closed Faraday chamber shall be EMI shielded.

*

6.2.3 Circuit grounding

The insulation values are summarized in Table 6-1.

BONDING RESISTANCE	INSULATION VALUES
Between any primary power supply pin and the bonding stud	$R \geq 1 \text{ MOhm}$ $C \leq 50 \text{ nF}$
Between primary power and secondary power	$R \geq 1 \text{ MOhm}$ $C \leq 50 \text{ nF}$
Between secondary power lines and the box structure (applies only when the secondary power return is disconnected from the ground)	$R \geq 1 \text{ MOhm}$ $C \leq 50 \text{ nF}$

Table 6-1: Bonding resistance insulation values

6.2.3.1 Power bus grounding

Reference **GDEL-215**

Structure shall not be used as a return current path.

*

Reference **GDEL-225**

The star grounding point shall be located in the power subsystem on the spacecraft (primary return to chassis star point).

*

Reference **GDEL-235**

The resistance between the star grounding point and the structure shall be less than 2.5 mOhm.

*

6.2.3.2 Secondary power grounding

Reference **GDEL-240**

Each user secondary power return shall be connected to a single ground (ground point / ground plane). This ground point / ground plane shall be connected to chassis.

*

In the case, of low power consuming unit the connection between secondary power reference and structure could be made via a loop on a connector (one pin is connected to the structure as near as possible, another is connected to the secondary power reference, they will be strapped on the connector). This design needs the Prime Contractor approval.

Reference **GDEL-270**

When a single converter via multiple windings supplies one or more equipment, the secondary power return shall be grounded to a single location within the supplied unit(s); one secondary power output shall not be distributed to more than one unit.

OK :**NOT OK :**

Figure 6-9: Secondary power output grounding rules.

*

GENERAL DESIGN AND INTERFACE REQUIREMENTS (GDIR)

REFERENCE : H-P-1-ASPI-SP-0027

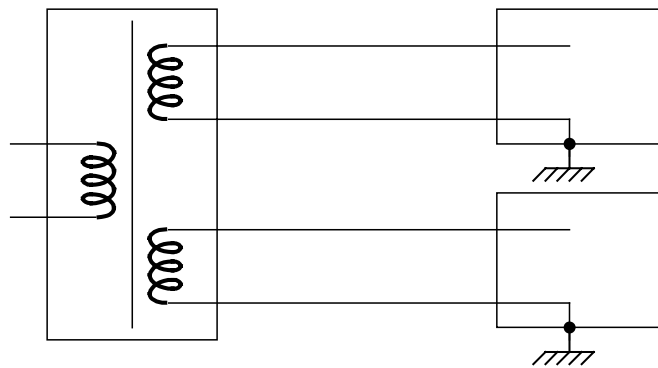
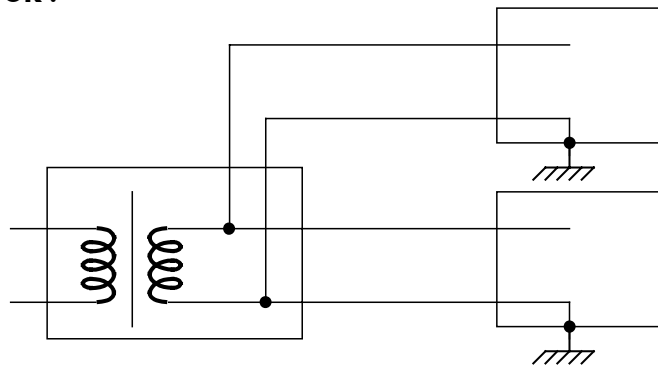
DATE : 25-Nov-2003

ISSUE : 4.2 PAGE : 82/118

Reference **GDEL-275**

Signal interfaces between these units or common interfaces with other boxes must provide appropriate isolation to avoid grounding loops.

*

Alternative concepts shall take into account return line voltage drops and shall be subjected to the Prime Contractor approval.

This applies to the converters located in the various subsystems/equipment's and in the power subsystem.

6.2.3.3 Signal return grounding

Reference **GDEL-280 b**

Any deviation w.r.t. the signal return configuration depicted in the figures of §6.8 shall be reported to the Prime Contractor through IDS's and approved prior implementation.

Note: primary power return is connected to chassis only within the PCDU

*

6.3 Charging/electrostatic discharge protection

Reference **GDEL-282**

[P:SCI-PT-RS-05991 - Ch.5#5.5.5.5-SENV-150 H/P

The exposed harness di-electric charging shall be taken into account and appropriate design provisions shall be taken. (SENV-150)

*

For other aspects, refer to EMC/ESD Specification (AD- 4).

6.4 Electromagnetic interface requirements

Refer to EMC/ESD Specification (AD- 4).

6.5 Magnetic cleanliness

Reference **GDEL-285**

The magnetic cleanliness shall be carefully controlled. The following magnetic fields shall be minimised:

- Permanent fields originating from magnetically hard ferromagnetic materials
- Stray-fields generated by current loops in the harness and inside electronic boxes
- Fields generated by electromagnetic actuating devices such as relays, valves, etc...

*

Reference **GDEL-290**

Also the use of soft magnetic materials with high permeability shall be avoided as far as possible

GENERAL DESIGN AND INTERFACE REQUIREMENTS (GDIR)

REFERENCE : H-P-1-ASPI-SP-0027

DATE : 25-Nov-2003

ISSUE : 4.2 PAGE : 83/118

*

Reference **GDEL-295**

The maximum emitted H-field allowed for each equipment shall be as defined in the EMC/ESD Specification (AD- 4).

*

6.6 Wiring and connections

6.6.1 General

Reference **GDEL-300**

[P:SCI-PT-RS-05991 - Ch.6#6.11.3-SMHA-045 H/P

[P:SCI-PT-RS-05991 - Ch.5#5.5.6-SENV-205 H/P

Physical separation along common runs of the categories listed below (power, signals and lines for the mechanisms, if applicable, RF coaxial cable and waveguide excluded) shall be retained between these categories up to and inclusive of the module interface connectors. Exceptions can be only the routing of harnesses down to connectors in the satellite separation plane.

- Category 1: power
 - primary power lines and heaters
 - solar array/power supply link
 - batteries/power supply link
- Category 2: digital signals and non sensitive analogue signals
 - TC signals
 - TM signals
 - DATA HANDLING links
 - Video signal links
- Category 3: lines for the mechanisms/pyrotechnics
- Category 4: sensitive analogue signals

(SMHA-045, SENV-205)

*

Reference **GDEL-305**

[P:SCI-PT-RS-05991 - Ch.6#6.11.3-SMHA-050 H/P

All equipment shall use a separate connector dedicated to its functional interface, according to the categories listed above. (SMHA-050)

*

Reference **GDEL-310**

[P:SCI-PT-RS-05991 - Ch.6#6.11.3-SMHA-055 H/P

GENERAL DESIGN AND INTERFACE REQUIREMENTS (GDIR)

REFERENCE : H-P-1-ASPI-SP-0027

DATE : 25-Nov-2003

ISSUE : 4.2

PAGE : 84/118

Wiring of redundant systems, subsystems or units of subsystems shall be routed through separate connectors and wire bundles. (SMHA-055)

*

Reference **GDEL-315**

[P:SCI-PT-RS-05991 - Ch.6#6.11.3-SMHA-060 H/P

Redundant wire bundles shall be routed differently wherever possible. (SMHA-060)

*

Reference **GDEL-320**

[P:SCI-PT-RS-05991 - Ch.6#6.11.3-SMHA-065 H/P

Cross strapping of redundant paths and circuits shall not be carried out in the harness. (SMHA-065)

*

Reference **GDEL-325**

[P:SCI-PT-RS-05991 - Ch.6#6.11.3-SMHA-070 H/P

The pyrotechnic harness shall satisfy the applicable safety requirements. (SMHA-070)

*

Reference **GDEL-330**

[P:SCI-PT-RS-05991 - Ch.6#6.11.3-SMHA-080 H/P

Connections to the initiators shall be capable of being mechanically broken during ground handling by safe/arm connectors accessible from the outside of the spacecraft. (SMHA-080)

*

Reference **GDEL-335**

[P:SCI-PT-RS-05991 - Ch.6#6.11.3-SMHA-085 H/P

The shields of cables shall not be used as return lines (SMHA-085)

*

Reference **GDEL-337**

[P:SCI-PT-RS-05991 - Ch.6#6.11.3-SMHA-090 H/P

All hot/return lines shall be twisted together. (SMHA-090)

*

Reference **GDEL-340**

[P:SCI-PT-RS-05991 - Ch.6#6.11.3-SMHA-095 H/P

All harness and all box and bracket mounted connectors supplying power shall have socket contacts (SMHA-095)

*

GENERAL DESIGN AND INTERFACE REQUIREMENTS (GDIR)

REFERENCE : H-P-1-ASPI-SP-0027

DATE : 25-Nov-2003

ISSUE : 4.2

PAGE : 85/118

Reference **GDEL-350**

[P:SCI-PT-RS-05991 - Ch.6#6.11.3-SMHA-105 H/P

The design shall ensure that 20% of the pins remain available at PDR for all foreseeable subsystem and experiment functions, and 10% at CDR (SMHA-105).

*

Reference **GDEL-355**

[P:SCI-PT-RS-05991 - Ch.6#6.11.3-SMHA-110 H/P

All individual wire-to-pin interfaces shall be covered with transparent heat shrink sleeves (SMHA-110)

*

Reference **GDEL-360**

[P:SCI-PT-RS-05991 - Ch.6#6.11.3-SMHA-115 H/P

The possibility of incorrect mating of connectors shall be excluded by design. (SMHA-115)

*

Reference **GDEL-365**

[P:SCI-PT-RS-05991 - Ch.6#6.11.3-SMHA-120 H/P

The harness connectors shall be easily accessible, attachable, and removable from the corresponding unit connectors; removal of units or disconnection of adjacent connectors shall not be necessary. (SMHA-120)

*

Reference **GDEL-370**

[P:SCI-PT-RS-05991 - Ch.6#6.11.3-SMHA-125 H/P

The harness shall be fixed onto the structure in order to avoid any damage during launch phase. As a general rule it will be fixed:

- at equipment level: the harness connector shall be fitted onto the equipment connectors by appropriate locking systems
- at the structure level
- at interface level: the connectors shall be fixed on metallic brackets themselves fixed onto the structure.

(SHMA-125)

*

Reference **GDEL-375**

[P:SCI-PT-RS-05991 - Ch.6#6.11.3-SMHA-130 H/P

Fixation of sensitive signal lines shall be such as to avoid micro-phonic noise. (SHMA-130)

*

Note : deleted.

Reference **GDEL-380**

[P:SCI-PT-RS-05991 - Ch.6#6.11.3-SMHA-135 H/P

GENERAL DESIGN AND INTERFACE REQUIREMENTS (GDIR)

REFERENCE : H-P-1-ASPI-SP-0027

DATE : 25-Nov-2003

ISSUE : 4.2 PAGE : 86/118

The harness restraining systems on the structure shall not bring about any stress at connector level. (SHMA-135)

*

Reference **GDEL-385**

[P:SCI-PT-RS-05991 - Ch.6#6.11.3-SMHA-140 H/P

The harness linking equipment mounted in or on the payload module, with the service module shall be such that the heat transferred by conduction is optimised for electrical and thermal performances (SHMA-140).

*

Reference **GDEL-390**

[P:SCI-PT-RS-05991 - Ch.6#6.11.3-SMHA-145 H/P

Permanent connections installed for the purposes of test at integrated satellite level shall be routed to skin connectors of the modules concerned (module interface connectors are no longer accessible at that level). (SHMA-145)

*

Reference **GDEL-395**

[P:SCI-PT-RS-05991 - Ch.6#6.11.3-SMHA-150 H/P

Skin connectors shall also be provided to make-or-break power circuits. (SMHA-150)

*

Reference **GDEL-400**

[P:SCI-PT-RS-05991 - Ch.6#6.11.3-SMHA-155 H/P

All these skin connectors shall be closed by caps, bridging connectors, and thermal insulation for flight. (SMHA-155)

*

6.6.2 Connectors

Reference **GDEL-415**

[P:SCI-PT-RS-05991 - Ch.6#6.11.3-SMHA-055 H/P

The demating of any connector shall not cause the loss of the mission (exceptions, if any, have to be agreed with the Prime Contractor).

*

6.6.2.1 Connector types

Reference **GDEL-420**

Connectors shall be selected from the EEE part list (AD- 37) and contain only gold plated contacts.

*

GENERAL DESIGN AND INTERFACE REQUIREMENTS (GDIR)

REFERENCE : H-P-1-ASPI-SP-0027

DATE : 25-Nov-2003

ISSUE : 4.2

PAGE : 87/118

6.6.2.2 Characteristics

Reference **GDEL-430**

Connectors at interfaces shall be clearly identified.

*

Reference **GDEL-435**

That applies to equipment connectors as well to interface brackets connectors:

- Pyrotechnic circuit connectors shall be separated from all other circuit connectors
- The housing of connectors shall be electrically connected to the equipment structure
- Type of connectors at interfaces must comply with the type of associated cable conductors
- Connector pins and sockets shall be removable on the harness connectors
- Male and female connectors shall be mechanically locked together, to prevent inadvertent disconnection
- Final selection of all connectors and connector accessories shall be submitted for approval by the Prime Contractor.

*

6.6.2.3 Connector mounting and identification

Reference **GDEL-440 a**

Equipment and bracket mounted connectors shall be located in easily accessible positions. The physical position is to be indicated on Interface Control Drawings and must be compliant with the minimum distances between connectors and mounting plane as described in Figure 6-11 (DxMA type only).

GENERAL DESIGN AND INTERFACE REQUIREMENTS (GDIR)

REFERENCE : H-P-1-ASPI-SP-0027

DATE : 25-Nov-2003

ISSUE : 4.2

PAGE : 88/118

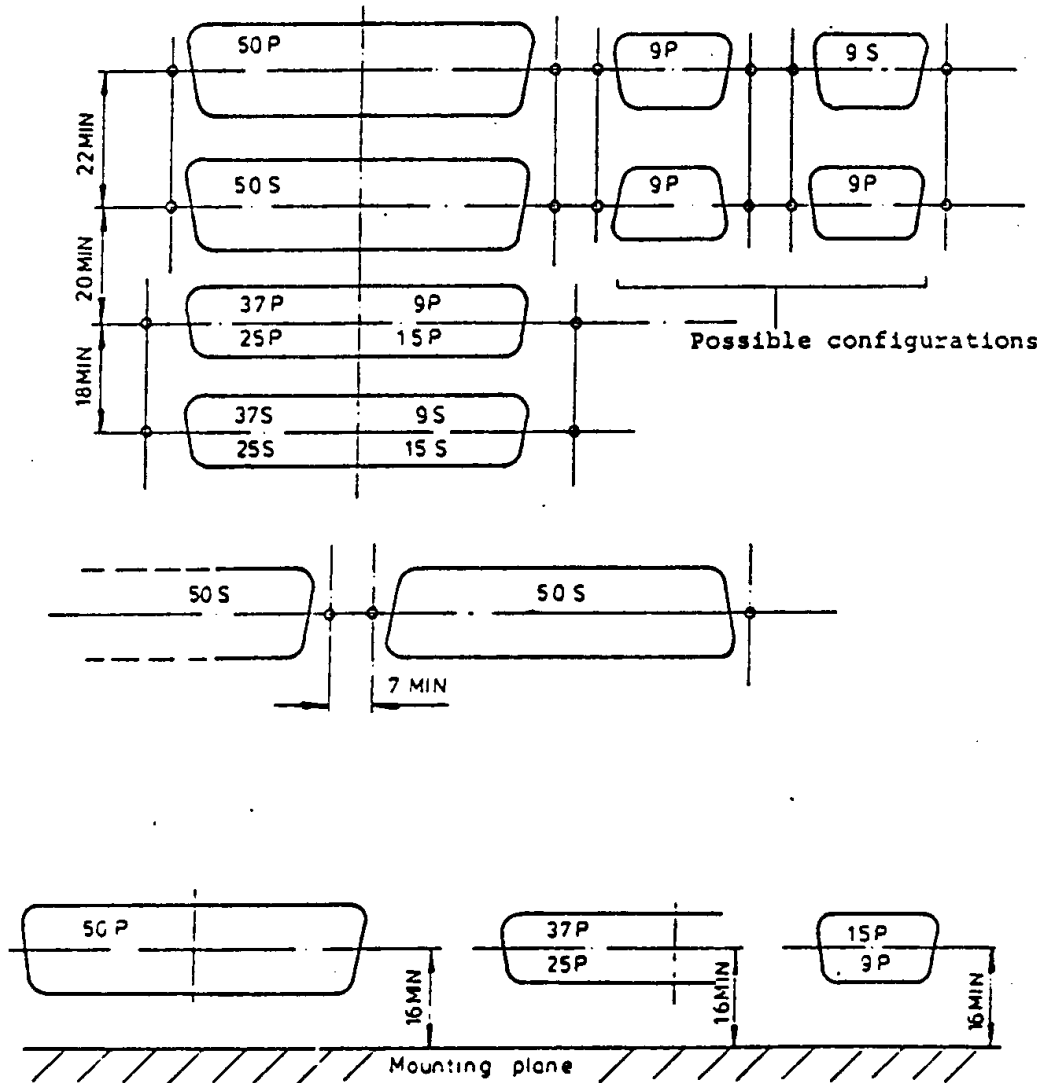

Figure 6-11: Location of Connectors

Note :

16 mm is a minimum distance that applies when the mounting plane offers a free access without obstruction to the connector. Note that a minimum distance of **20 mm** between the mounting plane and the connector lower end is recommended.

*

Reference **GDEL-445**

The harness connector identification shall comply with requirements below :

- each connector shall have its identification number marked on the shell or on a sleeve around the wires whichever is most appropriate
- the identification number shall be an unique seven characters number:
 - the first four for unit or bracket identification

GENERAL DESIGN AND INTERFACE REQUIREMENTS (GDIR)

REFERENCE : H-P-1-ASPI-SP-0027

DATE : 25-Nov-2003

ISSUE : 4.2

PAGE : 89/118

- the fifth for plug (P) or jacket (J) identification
- the two last for unit or bracket connector identification.

*

Reference **GDEL-450**

Mechanical methods in conjunction with identification markings shall be employed to prevent incorrect mating of connectors. Color coding may be used as an aid to identification.

*

6.6.2.4 Connector pin assignment and interface circuit data

Reference **GDEL-455**

To establish the electrical configuration at interfaces, the Interface Data Sheets shall include the following (this applies also to equipment test connectors) :

- type, the connector manufacturer's designation
- total number of pins, the number of pins capable of use in the connector, whether or not they are utilized in the particular interface configuration
- interface, the designation of the equipment (unit, assembly) interfacing
- subsystem, the subsystem associated with the connector
- mating connector, the designation (complete manufacturer reference) of the mating interface connector
- function, an explicit statement of the pin functions.

For return lines, however, the exact zero volt reference which the contact is connected to, shall be clearly indicated with reference to the grounding diagram:

- pin, the pin number or letter to which a connection is made
- cable screens, a simple drawing of the cable and screening arrangements at the connector.

*

Reference **GDEL-465**

In addition, a description diagram of optional detail shall indicate the layout of connectors and their position relative to the structure.

*

Reference **GDEL-470**

The connector designation of design authority and manufacturer, including keyway and insert arrangements, shall be indicated.

*

Reference **GDEL-475**

Critical cable lengths, for voltage drop reasons for instance, must be shown where applicable.

*

GENERAL DESIGN AND INTERFACE REQUIREMENTS (GDIR)

REFERENCE : H-P-1-ASPI-SP-0027

DATE : 25-Nov-2003

ISSUE : 4.2

PAGE : 90/118

6.6.2.5 Connector savers

Reference **GDEL-480**

For test purpose, flight connectors shall be protected against multiple mating/demating operations by connector savers.

*

Reference **GDEL-485**

Such connector savers shall be a flight type connector (same part number and same quality level):

- For test at unit or subsystem level, this applies to every equipment mounted connectors. In that case, each subsystem supplier is responsible for the procurement of those savers. These savers shall be delivered with the subsystem/unit. Those savers will be reused at system level if necessary.
- For system level tests, the following applies:
 - i.** 1 saver for each test connector at system level
 - ii.** 1 saver per interface connector
 - iii.** 1 saver per separation plug (umbilical)

These last types of savers (**i. to iii.**) shall be procured by the harness subsystem and delivered as part of the Spacecraft System.

*

6.6.3 Shielding, redundancy and identification

6.6.3.1 Twisted and shielded lines / Overshielding

6.6.3.1.1 Twisted and shielded lines

Reference **GDEL-490**

The twisted wires shall be routed through a connector on adjacent pins to minimize the wire loop.

*

Reference **GDEL-495**

Signal interface harnesses, in general shall be constructed using twisted shielded wires. However, some pulse commands, thermistors lines and relay driver lines will not be shielded in order to save weight on the satellite. In this case, EMI analysis shall be performed to ensure EMC/ESD requirement compliance.

*

Reference **GDEL-500**

Power lines shall be twisted pairs. If however any supplier intends to use shielded wires for power or high power ON/OFF command lines, it shall be submitted to prime Contractor.

*

GENERAL DESIGN AND INTERFACE REQUIREMENTS (GDIR)

REFERENCE : H-P-1-ASPI-SP-0027

DATE : 25-Nov-2003

ISSUE : 4.2 PAGE : 91/118

Reference **GDEL-505**

[P:SCI-PT-RS-05991 - Ch.6#6.11.3-SMHA-075 H/P

The pyrotechnic harness shall consist of twisted pairs of wires with an overall shield being continuous and connected to the conductive connector shells at all interfaces and grounded to the structure at all intermediate attachment points (SMHA-075)

*

Reference **GDEL-510**

Neither the structure nor any cable shield shall be used to carry bus power return. This will minimize common mode noise input to the units.

*

Reference **GDEL-515**

[P:SCI-PT-RS-05991 - Ch.6#6.11.3-SMHA-100 H/P

Shields shall always be connected to connector shells which will be grounded at any intermediate connectors. (SMHA-100)

*

Daisy chaining of shield connections to ground is prohibited.

Reference **GDEL-525**

The resistive between cable shield and the adjacent grounding point shall be less than 2.5 mΩ.

*

6.6.3.1.2 Overshielding

Reference **GDEL-530**

For sensitive and critical functions, overshield shall be added that is continuous from the backshells of each of the associated unit connectors. All shields shall be terminated to chassis external to the unit enclosure.

*

Reference **GDEL-535**

Every cable submitted to the external environment (i.e. external to the Spacecraft) shall be overshielded. Where external cables penetrate the enclosure of the spacecraft main body, they shall be terminated to the structure externally.

All these Overshield shall be grounded :

- All overshielded grounding shall be accomplished with 360 deg conductive backshells. These backshells shall make use of connectors that have circumferential "grounding" fingers that coaxially enclose all pins and provide the ground path for the shield to structure
- Those overshields not under MLI blanketing (and therefore visible from outside the Spacecraft shall have their jacketing material wrapped with a material having a metallized outer layer. This layer shall be grounded to structure (usually by the backshell).

*

GENERAL DESIGN AND INTERFACE REQUIREMENTS (GDIR)

REFERENCE : H-P-1-ASPI-SP-0027

DATE : 25-Nov-2003

ISSUE : 4.2

PAGE : 92/118

6.6.3.2 Wiring Redundancy

Reference **GDEL-540**

The wiring including pins and sockets of connectors shall be made redundant at all critical interfaces, a failure of which would cause catastrophic failure of the spacecraft system.

*

Reference **GDEL-545**

When equipment is made redundant, the associated wiring shall be redundant in the same manner.

*

This includes primary power interfaces.

6.6.4 Wiring rules

Reference **GDEL-547**

Wire type shall be selected from the ESA EEE preferred Parts List (AD-37) unless explicitly specified by the detailed interface requirements.

*

Note : Such detailed interface requirements are for example foreseen for the 1553 cable and the SPDL cables.

6.6.4.1 Crimping of wires

Reference **GDEL-550**

Crimping method shall meet the requirements of AD- 38.

*

Reference **GDEL-555**

Everywhere crimping and soldering methods are usable, for the same type of connectors, crimping ones shall be preferred.

*

Smaller gauges of wire than those specified for particular connector pins are not to be used.

Folding over of wires for crimping is not allowed.

Procedures must be prepared to define adequately the inspection techniques which must be used to verify the reliability of braided shield and coaxial screen connections.

6.6.4.2 Soldering of wires

Reference **GDEL-565**

Soldering method shall meet the requirements of AD- 39.

*

GENERAL DESIGN AND INTERFACE REQUIREMENTS (GDIR)

REFERENCE : H-P-1-ASPI-SP-0027

DATE : 25-Nov-2003

ISSUE : 4.2

PAGE : 93/118

6.6.4.3 Current derating of wires

Reference **GDEL-570**

The maximum current allowed per type of gauge shall not exceed the value given in Table 6-2

Wire size AWG	Maximum supplied voltage = 50% of the specified maximum insulation voltage													
	30	28	26	24	22	20	18	16	14	12	10	8	6	4
Isw (A)	1.1	1.8	2.5	3.3	4.5	6.5	9.2	13	17	23	33	44	60	81

Isw = Maximum applied current versus the wire size in a maximum ambient temperature of **85 °C for a single wire**

Ibw = Maximum applied current versus the wire size in a maximum ambient temperature of **85 °C when wires are bundled.**

The relationship between **Ibw** and **Isw** is given by the following formula :

$$\mathbf{Ibw} = \mathbf{Isw} \times (29 - N) / 28 \text{ for } 1 \leq N \leq 15$$

N = Number of wires in the bundle

or $\mathbf{Ibw} = 1/2 \times \mathbf{Isw}$ for $N > 15$

Table 6-2: Wires Current Derating Criteria

*

6.7 Electrical POWER SYSTEM INTERFACE

6.7.1 Power supply voltages

The DC main bus is regulated to 28 V with a maximum tolerance at the source (regulation point) of +1 % / -2 %. This tolerance includes effects of load regulation, temperature and ageing.

Each Distribution Unit output is protected by a Latch Current Limiter (LCL) or Fold-back Current Limiter (FCL).

In case of a redundant user, a non-redundant protection is provided for each redundancy.

In case of a non-redundant user, a redundant protection is provided for the user.

Reference **GDEL-575**

Each satellite user Subsystem/Equipment shall be able to operate nominally within the following steady state voltage limits (applicable to S/C harness-Subsystems interface i.e. the voltage drop inside the Subsystem harness is not covered by these limits) :

- 26 V as minimum voltage (mean voltage excluding any noise, ripple and spikes). If the bus voltage falls below 26 V, then all units connected to the bus shall operate in a predictable way that shall not interfere with functioning redundant units ;
- 29 V as maximum voltage (mean voltage excluding any noise, ripple and spikes).

This range shall be used to establish Subsystem or Unit power budgets as reported in the IDS.

*

GENERAL DESIGN AND INTERFACE REQUIREMENTS (GDIR)

REFERENCE : H-P-1-ASPI-SP-0027

DATE : 25-Nov-2003

ISSUE : 4.2

PAGE : 94/118

Reference **GDEL-580**

All the users shall safely survive when being supplied with any continuous or fluctuating voltage in the full range 0V ↔ 32 V. In this case, survive means that equipment have to recover their nominal performance capabilities when the main bus recovers its nominal voltage.

*

6.7.2 Voltage transients and ripple

Transients and overvoltages are specified in the EMC Specification (document AD- 4).

Reference **GDEL-585**

The ripple and spikes shall be less than (at Distribution Unit output connectors):

- 140 mV peak to peak for ripple
- 300 mV peak to peak for ripple + spikes

on 28 V lines.

This peak to peak value is defined in a 50 MHz bandwidth.

*

6.7.3 Bus output impedance

Reference **GDEL-590 a**

The primary bus impedance at S/C harness-Subsystem interface level (interface connector level) is specified in Figure 6-13.

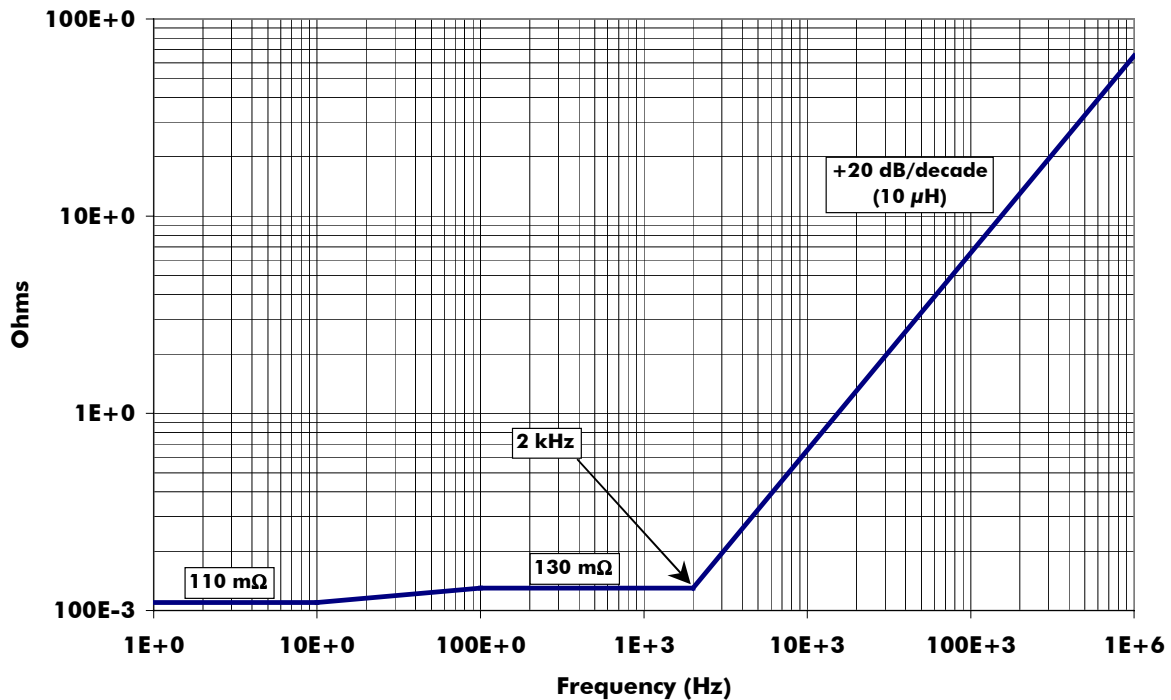

Figure 6-13: Bus Impedance at S/C Harness-User Subsystem Interface

*

6.7.4 Current limiter characteristics

Reference **GDEL-602**

Three types of current limiters shall be available:

- ON/OFF switchable Latching Current Limiters (LCL) for "non-essential" loads, i.e. for those items which do not jeopardise the spacecraft if they are switched OFF. Two levels of OFF command shall be provided within the LCL for those LCLs whose users cannot tolerate a failed permanent ON condition.
- Permanent ON Fold-back Current Limiters (FCL) for essential loads (receiver, decoder, ...).
- Heater Control Switches (HCS) + Heater-group Protection Switches (HPS) for resistive loads (heaters).

*

Reference **GDEL-600 a**

The LCLs used in the power subsystem (equipments and instruments power supply lines) shall have the following characteristics:

- Except during the first 50 μs of operation (ie switch on or entry into protection mode), the current limitation shall be set at a value I_{limit} in the range $I_{limit\ min} \leq I_{limit} \leq I_{limit\ max}$. Class of the LCL, corresponding I_{class} , $I_{limit\ min}$ and $I_{limit\ max}$ are defined in Table 6-4.
- If the current exceeds I_{limit} for a time greater than T_{trip} , then the LCL will automatically switch-off.

- During the first 50 μ s of operation (ie switch on or entry into protection mode), the overshoot current $I_{overshoot}$ shall not exceed I_{limit} by more than 50% (see Figure 6-15).
- The LCL shall have a power bus under-voltage detector.
- The LCL under-voltage threshold shall be settable during manufacture between 21 and 26 V with an accuracy better than ± 0.25 V.
- If the power bus voltage falls below the under-voltage threshold for more than 50 μ s (microseconds), then the LCL shall be latched off.
- It shall be possible to determine the status of each LCL via the 1553 data bus, including ON/OFF condition, latch status and output current (accuracy $\pm 5\%$).

LCL Type	I_{class}	$I_{limit\ min} = 1.2 I_{class}$	$I_{limit\ max} = 1.5 I_{class}$	$I_{overshoot}$	$T_{trip\ min}$	$T_{trip\ max}$
Class I	1 A	1.2 A	1.5 A	2.25 A	10 ms	12 ms
Class II	2.5 A	3.0 A	3.75 A	5.63 A	10 ms	12 ms
Class III	5 A	6.0 A	7.5 A	11.25 A	10 ms	12 ms

Table 6-4 : Definition of the LCL classes and corresponding I_{class} , $I_{limit\ min}$ and $I_{limit\ max}$

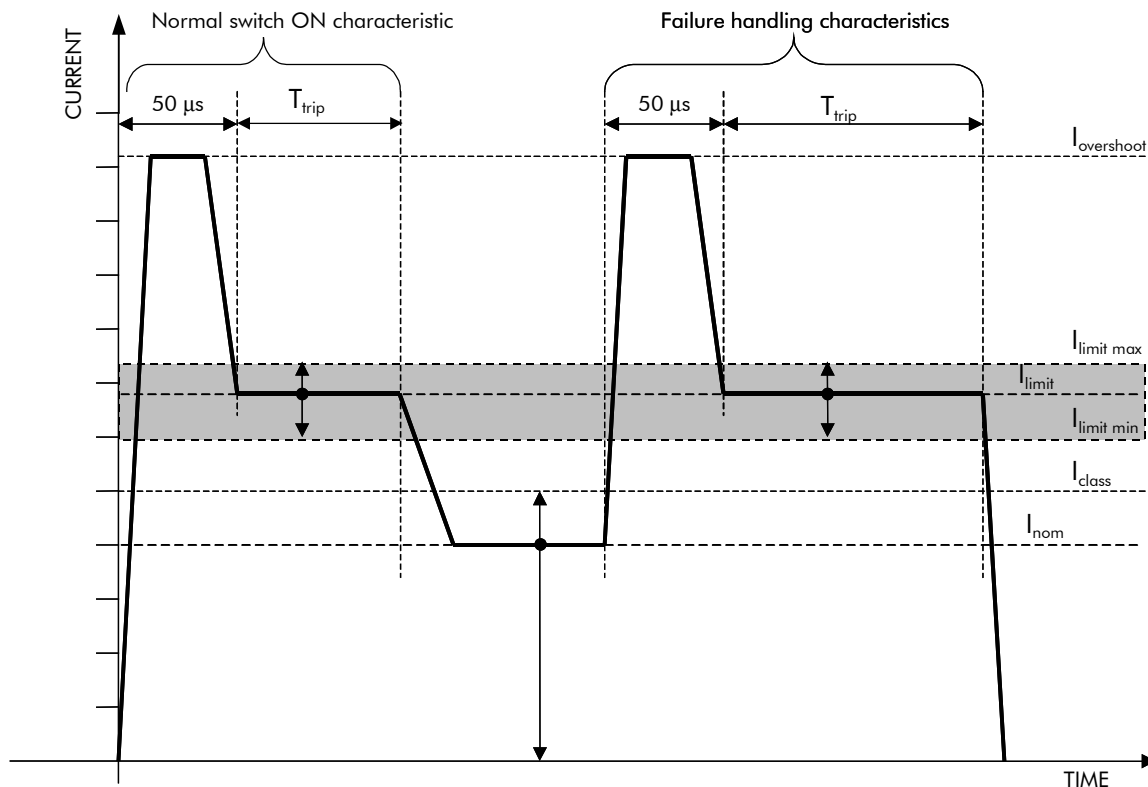

Figure 6-15 : LCL characteristics

*

Note :

GENERAL DESIGN AND INTERFACE REQUIREMENTS (GDIR)

REFERENCE : H-P-1-ASPI-SP-0027

DATE : 25-Nov-2003

ISSUE : 4.2

PAGE : 97/118

- It is possible to parallel LCLs to achieve a higher current capacity (e.g. 20 A for the Sorption Cooler can be achieved with 4 Class III LCLs).
- I_{class} shall be chosen higher than the maximum current I_{max} , I_{max} being the current related to peak power calculated assuming the minimal supply voltage as defined in 6.7.6 "short peak definition".

Reference **GDEL-601**

The FCLs shall have the same constraints and requirement as the standard LCL except for the following.

- It shall not be possible to switch/latch off an FCL.
- FCLs shall have the characteristics given in Table 6-5 and Figure 6-16.
- No single fault shall result in the loss of more than one FCL.
- It shall be possible to determine the status of each FCL via the 1553 data bus, including output voltage and output current.

Type	I_{class}	$I_{limit\ min}$	$I_{limit\ max}$	$I_{overshoot}$
FCL	1 A	0.25 A	1.5 A	2.25 A

Table 6-5 : FCL characteristics

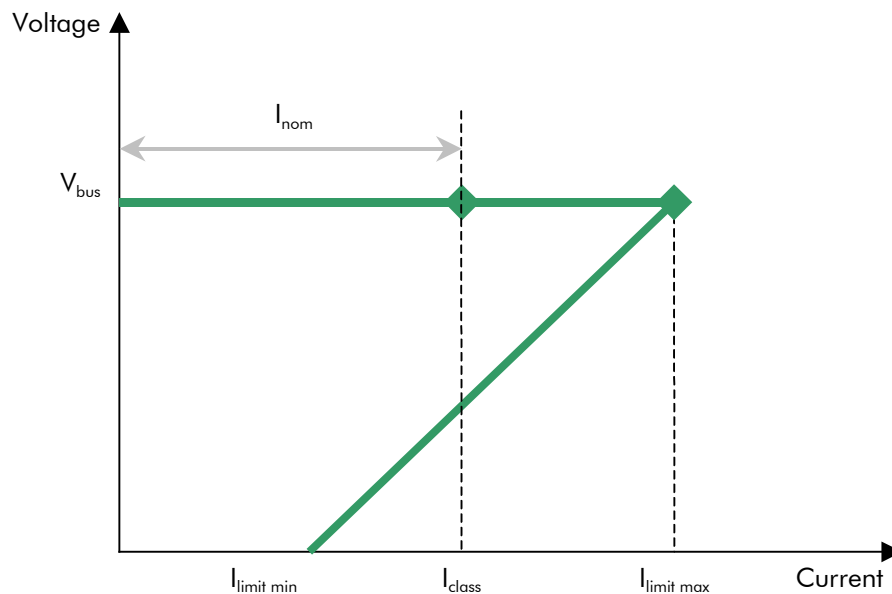

Figure 6-16 : FCL current-voltage characteristics

*

Reference **GDEL-604 a**

The Heater Control Switches (HCS) and Heater-group Protection Switches (HPS) shall have the following characteristics :

- Each HCS shall be rated to 3.75 A.
- The HCS ON/OFF shall not exceed 1 A/ μ s (Ampere per microsecond).
- The maximum leakage current per HCS when OFF shall not exceed 500 μ A (microAmpere).

GENERAL DESIGN AND INTERFACE REQUIREMENTS (GDIR)

REFERENCE : H-P-1-ASPI-SP-0027

DATE : 25-Nov-2003

ISSUE : 4.2

PAGE : 98/118

- A group of HCS shall be supplied and protected by a HPS.
- The HPS shall trip off if a current higher than 12 A (± 0.5 A) is exceeded during more than 50 μ s (microseconds).
- The HPS shall be commanded ON/OFF (RESET) via the 1553 data bus.

*

6.7.5 Heaters line

The PCPU will provide switchable power lines protected by an HPS suitable to drive a resistive heater load.

Reference **GDEL-603**

The maximum voltage drop due to the HPS + HCS shall be $V_{\text{drop}} \leq 1$ V.

*

6.7.6 Average power demand definition

The **average power** demand is defined for an equipment as the maximum average power drawn from its dedicated power lines in the worst case voltage conditions of paragraph 6.7.1.

Specifically, the **maximum average** is defined as the average during a period of 5 minutes shifted to any point in time where this average will yield a maximum and does not include peak power defined hereafter.

Reference **GDEL-605**

Each subsystem shall define its average power requirement per power line.

*

6.7.7 Peak power demand definition

Long peak

Long peak power demand is defined for an equipment as the maximum peak drawn from its dedicated power lines, in the worst case voltage conditions of paragraph 6.7.1.

Specifically, the maximum long peak is defined using the integral during a period of 5 minutes shifted to any point in time over 100 minutes where the integral will yield a maximum.

Short peak

Short peak power demand is defined for an equipment as the maximum peak drawn for its dedicated power lines in the worst case voltage conditions of paragraph 6.7.1.

Specifically, the maximum short peak is defined using the integral during a period of 1 ms shifted to any point in time where the integral will yield the maximum.

To be defined as a short peak, the power demand shall last less than 100 ms.

Reference **GDEL-610**

Each subsystem shall define its long and short peak power requirement per power line.

*

6.7.8 Distribution and Protection Requirements

Reference **GDEL-615 a**

Any standing or variable current drawn by any unit from the supply lines shall be limited by the Power Supply to a value I_{limit} defined in 6.7.4 under nominal conditions.

*

Such a limitation is achieved by active current limiter on the power lines.

Reference **GDEL-620**

In particular, this limit shall be sustained for a single part failure at user's input and for the full voltage range specified (see paragraph 6.7.1).

*

Reference **GDEL-625**

The use of current protection circuits on the primary side of user DC/DC converters shall be avoided since the PCDU LCLs will provide all the necessary protection. If the use of protection circuits cannot be avoided, then the protection threshold shall be set lower than the PCDU LCL and tests must be performed with a representative PCDU LCL as early as possible.

*

Reference **GDEL-627**

Overvoltage protection circuits on the primary side of user DC/DC converters shall be avoided since the PCDU LCLs will provide all the necessary protection. The user may incorporate overvoltage protection on the secondary side of the DC/DC converter. When undervoltage protection circuits are implemented, their interaction with the PCDU LCL shall be studied/tested to avoid conditions where overloads interacting with the PCDU LCL may cause oscillating currents in the power bus.

*

6.7.9 Load current transitions

6.7.9.1 In-rush current

Reference **GDEL-635**

When connected to a non limiting current source (in test configuration) the inrush current at switch-on of the equipment shall be within the envelop defined in AD- 4, § 3.2.4.8.2.

*

Reference **GDEL-640**

When connected to a LCL the inrush current at switch-on will be constrained to the envelope shown in Figure 6-18 by the Power Distribution Unit.

In this condition the user shall operate nominally (nominal current I_{nom} under nominal voltage) before T_{trip} .

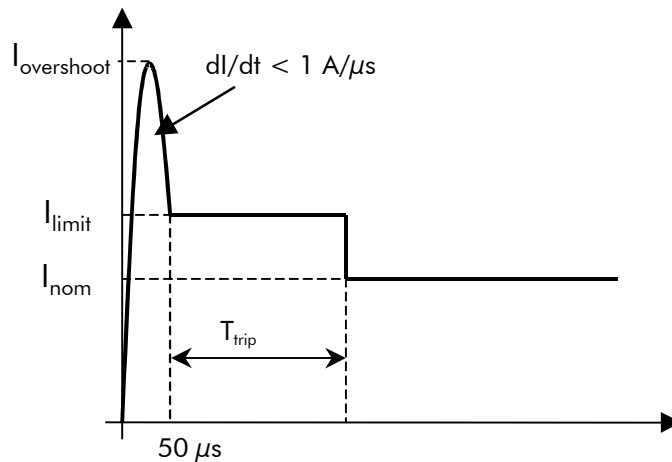

Figure 6-18 : Nominal current envelope

*

6.7.9.2 Load current transitions

In case of step or pulse transitions of supply current demand the transient voltage remains into limits given in EMC/ESD specification (AD- 4).

Reference **GDEL-645**

Users shall not exceed their I_{limit} during any planned operations.

*

Reference **GDEL-650**

The LCL user shall not require an instantaneous rate of change of current (di/dt) higher than 10^6 A/s either positive or negative.

*

Reference **GDEL-655**

Pulse repetition frequency shall not exceed 1 Hz unless confined to the limits of admissible ripple current as specified in EMC/ESD specification (AD- 4).

*

6.7.10 Insulation of the power lines

Reference **GDEL-660**

Prior to the mating of power line and equipment connectors, the galvanic insulation between any power supply pin and the bonding stud of the equipment housings in functional configuration shall be equivalent to:

- a resistor of 1 Mega Ohm minimum
- a capacitor of 50 nano Farad maximum.

*

GENERAL DESIGN AND INTERFACE REQUIREMENTS (GDIR)

REFERENCE : H-P-1-ASPI-SP-0027

DATE : 25-Nov-2003

ISSUE : 4.2 PAGE : 101/118

Reference **GDEL-665**

Insulation quality shall be as specified for 100 VDC at both polarities.

*

Reference **GDEL-670**

For purposes of verification, this 100 VDC (+ 5 V, - 0 V tolerance) shall be applied at a rate of not less than 50 V/s for a test period of 60 (+ 10, - 0) seconds.

*

Reference **GDEL-675**

For test purpose, all hot and return lines shall be externally short circuited.

*

Reference **GDEL-680**

[P:SCI-PT-RS-05991 - Ch.5#5.5.6-SENV-200 H/P

In addition, the primary power lines shall be transformer insulated from all secondary power. (SENV-200)

*

6.7.11 Isolation

Reference **GDEL-700**

For any LCL or HCS+HPS in the PCDU which is commanded OFF, the isolation quality shall be such as to limit any "leakage" current on the power line output to a maximum of 500 μ A (microAmpere).

*

6.7.12 DC/DC converter synchronisation

Reference **GDEL-705**

DC/DC converters on the Herschel and Planck shall be free running.

*

Reference **GDEL-710 a**

[P:SCI-PT-RS-05991 - Ch.5#5.5.6-SENV-185 H/P

DC/DC converters switching frequency shall be between 30 kHz and 600 kHz in order to be outside of the critical operating bandwidth of the instruments.

*

6.7.13 NCA

NCA (Non Contamination Actuator) command is required to command the opening of the Herschel cryostat cover. Their characteristics are:

- Source impedance : 0.8 Ω to 1.0 Ω at ambient temperature
- Command pulse duration: minimum 120 ms, maximum 500 ms
- Note: In order to meet this NCA characteristic, the PCDU shall produce a firing pulse for the NCA device during a duration comprised between 200 ms and 400 ms.
- Firing current: minimum 3.5 A, maximum 6 A
- Non firing current: 0.4 A DC permanent. For test purposes, a current of 0.8 A DC shall be applied during 5 minutes at ambient temperature without firing the NCA.

6.8 Data Handling interfaces

In the tables of this section :

- "Voltage drop" includes wires and contacts (signal and return).
- The capacitance of the line characteristics is not intended to be verified at harness level, except for specific interfaces such as with SBDL and 1553.

6.8.1 Commands Interfaces

6.8.1.1 High Priority (HP) or High Level Commands (HL)

The command signal is a single ended positive voltage pulse, distributed to the user on a dedicated line for Relay or Opto-coupler driving.

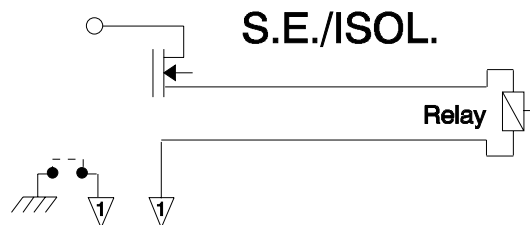

Figure 6-24 : Electrical scheme of a command line driving a relay

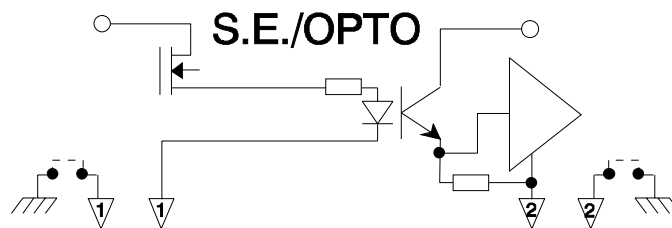

Figure 6-26 : Electrical scheme of a command line driving an opto-coupler

GENERAL DESIGN AND INTERFACE REQUIREMENTS (GDIR)

REFERENCE : H-P-1-ASPI-SP-0027

DATE : 25-Nov-2003

ISSUE : 4.2 PAGE : 103/118

The interface characteristics are :

	SOURCE	LOAD
CIRCUIT TYPE	Single ended driver	Relay
VOLTAGE - Active voltage - Passive voltage	22 V < U < 29 V (when load > 162 Ω) 0 V < U < 2 V	Max switching threshold: [a] < 22 V ; [b] < 16.6 V Min switch. threshold > 4V
CURRENT - Sinking current - Driving capability - Leakage - Short circuit	< 50 μA ≥ 180 mA (with U > 16.6V) ≥ 135 mA (with U > 22 V) ≤ 2.5 μA ≤ 400 mA (during pulse)	[b] Rmin > 92 Ω [a] Rmin > 162 Ω
SIGNAL SHAPE - Pulse length (Tp) - Rise time(10%-90%) - Fall time(10%-90%)	26 ms ± 2 ms 50 μs < Tr < 500 μs (*) 50 μs < Tf < 500 μs (*)	
CAPACITY	< 50 pF	< 300 pF
REPETITION RATE	Pulse rate < 4 Hz	
FAILURE CASE - Max. Emission - Tolerance	0 V < U < 33 V (current limited to 400 mA) The interface shall withstand a permanent short circuit condition between + & return outputs with no resulting damage -5 V < U < 48 V	+ & return short circuit -5 V < U < 48 V 0 V < U < 33 V (Fault source limited to 400 mA)
LINE CHARACTERISTICS Type Total Differential Capacitance Total Voltage Drop		Twisted-AWG26 < 600 pF < 240mV

* = when loaded by 270 Ω in parallel with 0.6 nF

Table 6-7 : HP or HL commands interface characteristics for relay

GENERAL DESIGN AND INTERFACE REQUIREMENTS (GDIR)

REFERENCE : H-P-1-ASPI-SP-0027

DATE : 25-Nov-2003

ISSUE : 4.2

PAGE : 104/118

	SOURCE	LOAD
CIRCUIT TYPE	Single ended driver	Opto-coupler
VOLTAGE - Active voltage - Passive voltage	22 V < U < 29 V (when load > 162 Ω) 0 V < U < 2 V	Max switching threshold: < 14 V Min switch. threshold: > 5 V
CURRENT - Sinking current - Driving capability - Leakage - Short circuit	< 50 μA ≥ 10 mA ≤ 2.5 μA ≤ 400 mA (during pulse)	Min. current > 2.5 mA
SIGNAL SHAPE - Pulse length - Rise time(10%-90%) - Fall time(10%-90%)	Tp = 26 ms ± 2 ms 50 μs < Tr < 500 μs (*) 50 μs < Tf < 500 μs (*)	<u>command validation:</u> time threshold ≥ 5 ms
CAPACITY	< 50 pF	< 300 pF
° REPETITION RATE	Pulse rate < 4Hz	
FAILURE CASE - Max. Emission - Tolerance	0 V < U < 33 V (Fault source imp. ≥ 1.5 kΩ) The interface shall withstand a permanent short circuit condition between + & return outputs with no resulting damage -5 V < U < 48 V	+ & return short circuit -5 V < U < 48 V » 0 V < U < 33 V (Fault source imp. ≥ 1.5 kΩ)
² LINE CHARACTERISTICS Type Total Differential Capacitance Total Voltage Drop		Twisted-AWG26 < 600 pF < 240mV

* = when loaded by 10kΩ in parallel with 0.6 nF

Table 6-9 : HP or HL commands interface characteristics for opto-coupler

The HP & HL commands delivered by Data Handling to user Subsystems are only of one type and are able to drive 180 mA (relay command type).

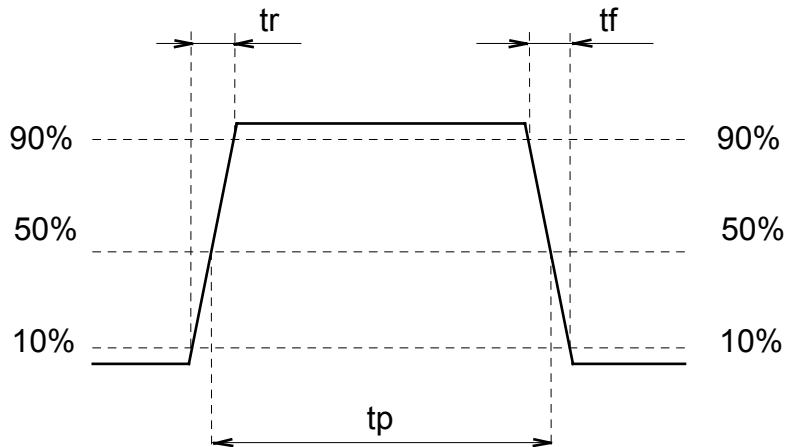

Figure 6-19 : Signal waveform for the HLC pulses

6.8.1.2 Extended High Level Commands (EHL)

The command signal is a single ended positive voltage pulse, distributed by the Data Handling to the user. The interface characteristics are the same than HL and HP ones except:

	SOURCE	LOAD
CIRCUIT TYPE	Single ended driver	Relay-Switch I/F
SIGNAL SHAPE Pulse length	500 ms \pm 5 ms	

Table 6-11 : EHL commands interface characteristics

6.8.1.3 Low level command

The LLC are of SBDL type as described in section 6.8.1.4. The pulse duration shall be > 10 ms.

6.8.1.4 The Standard Balanced Digital Link (SBDL)

The Standard Balanced Digital Link (SBDL) is a fully differential interface, with a "true line" and a "complementary line" (see Figure 6-20). The status of the signal is defined as high when the true line has a positive voltage "1" level with reference to the ground and the complementary line has a "0" level with reference to the ground. The signal is defined as low when the true line is at "0" and the complementary line is at "1".

GENERAL DESIGN AND INTERFACE REQUIREMENTS (GDIR)

REFERENCE : H-P-1-ASPI-SP-0027

DATE : 25-Nov-2003

ISSUE : 4.2

PAGE : 106/118

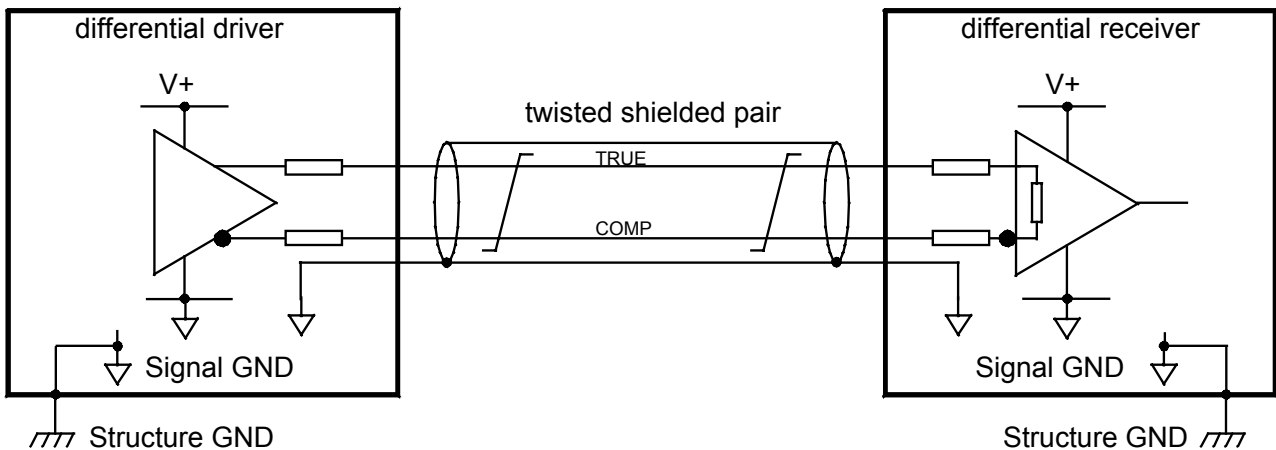

Figure 6-20 : Schematic Electrical interface for the SBDL

Reference GDEL-711

To ensure the maximum of compatibility and the minimum of risk, the SBDL interface shall be implemented using the components as shown in Figure 6-22. Additional protection components (to provide protection during on-ground operations) may be added as deemed necessary by the circuit designer.

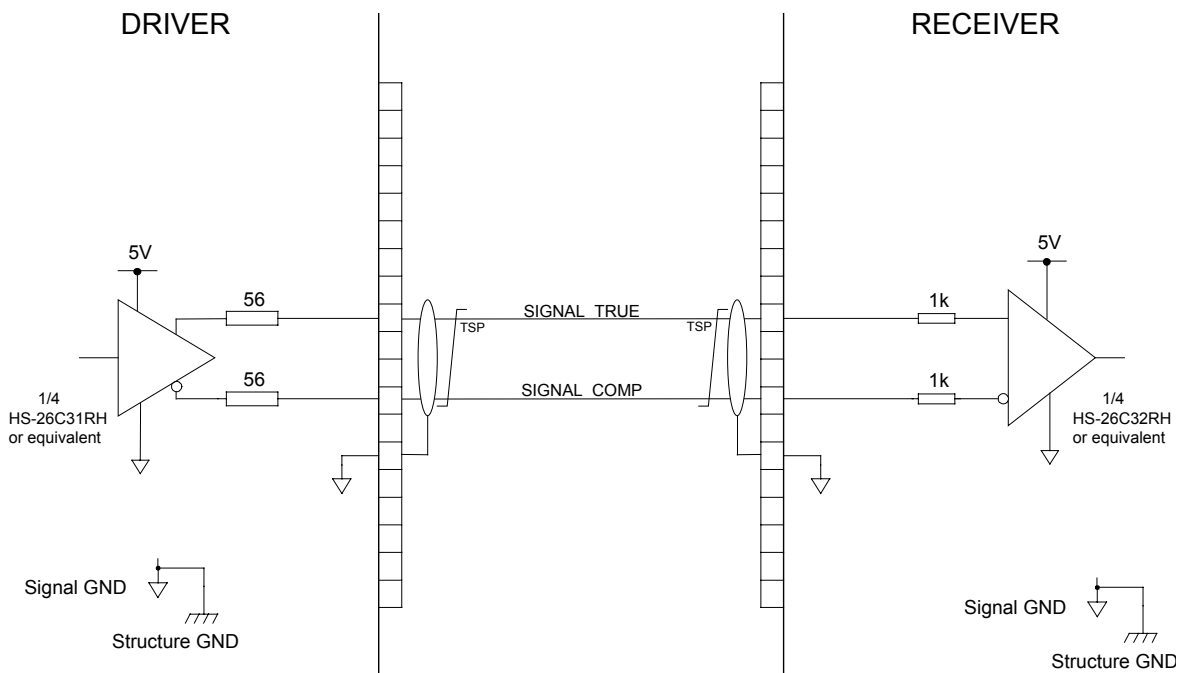

Figure 6-22 : SBDL Interface Details

*

GENERAL DESIGN AND INTERFACE REQUIREMENTS (GDIR)

REFERENCE : H-P-1-ASPI-SP-0027

DATE : 25-Nov-2003

ISSUE : 4.2

PAGE : 107/118

Driver Characteristics

DRIVER	
CIRCUIT TYPE	Complementary CMOS Driver
Zero Reference	signal ground
Low Level Output Voltage	$0\text{ V} \leq V_{OL} \leq 0.5\text{ V}$ (1)
High Level Output Voltage	$2.5\text{ V} \leq V_{OH} \leq 5.5\text{ V}$ (1)
Differential Output Voltage	$2.0\text{ V} \leq V_{OD} \leq 5.5\text{ V}$
Rise and Fall Times	$0.1\ \mu\text{s} \leq t_r \leq 0.80\ \mu\text{s}$ (2) $0.1\ \mu\text{s} \leq t_f \leq 0.30\ \mu\text{s}$
Differential Output Impedance	$115\ \Omega < Z_d < 125\ \Omega$
Current Drive and Sink Capability	sufficient to comply with specified t_r & t_f (2)
Short Circuit	short circuit proof; current limited to $< 150\text{ mA}$
Max. Fault Voltage	Tolerance: -12 V to $+12\text{ V}$ (3) Emission: 0V to $+5\text{V}$
NOTES: 1. non-inverting (true) & inverting (comp) output with ref. to signal ground; 2. when loaded with differential 1.2 nF (harness & user input capacitance) 3. with an overvoltage source impedance of $1.5\text{ k}\Omega$	

Table 6-13 : SBDL driver characteristics

Line Characteristics

LINE CHARACTERISTICS	
Type of cable	125 Ohm TwinAx Cable to be used: Gore GSC 6509, Rev. 6

Table 6-15 : SBDL line characteristics

GENERAL DESIGN AND INTERFACE REQUIREMENTS (GDIR)

REFERENCE : H-P-1-ASPI-SP-0027

DATE : 25-Nov-2003

ISSUE : 4.2

PAGE : 108/118

Receiver Characteristics

		RECEIVER
CIRCUIT TYPE	Complementary CMOS Driver	
Differential Input Voltage	Low : $V_{ID} \leq -1V$ High $V_{ID} \geq +1V$	
Common Mode Voltage	$-2.5 V \leq V_{CM} \leq +2.5 V$	
Diff. Input Impedance	DC: $\geq 5 \text{ kOhm}$	
Max. Fault Voltage	Tolerance: $-0.5 V \text{ to } +7 V$ Emission: $0 V \text{ to } +5V$	(1)
NOTES:	1. with an overvoltage source impedance of 1.5 kOhm	

Table 6-17 : SBDL receiver characteristics

6.8.1.5 Memory Load Command (ML16)

The purpose of the Memory Load Command (or 16 bits serial load command) link is to transfer a 16 bits data word in serial form.

Any undefined ML16 bit pattern (bit pattern having no predefined interpretation or decoding sense at user level) shall be ignored by the addressed user.

The interface consists of the following 3 signals :

- Sample (or address)

The user will be provided with a dedicated address line for each ML16.

- Clock

One Clock line is provided to each user. Clocks pulses are provided simultaneously to all users. 16 of these Clocks pulses are gated during the Address (Sample) signal interval, together with 16 bits Data, thus enabling the user to read the Data after detection of one of its addresses. The Clock pulses have a known and reliable phase relationship with the NRZ-L Data transitions, thus ensuring reliable Data read-in by the user.

- Data

One Data line (16 bits serial NRZ-L) is provided to each user.

ML16 command protocol and signal wave form

The Serial command timing is according to the figure below.

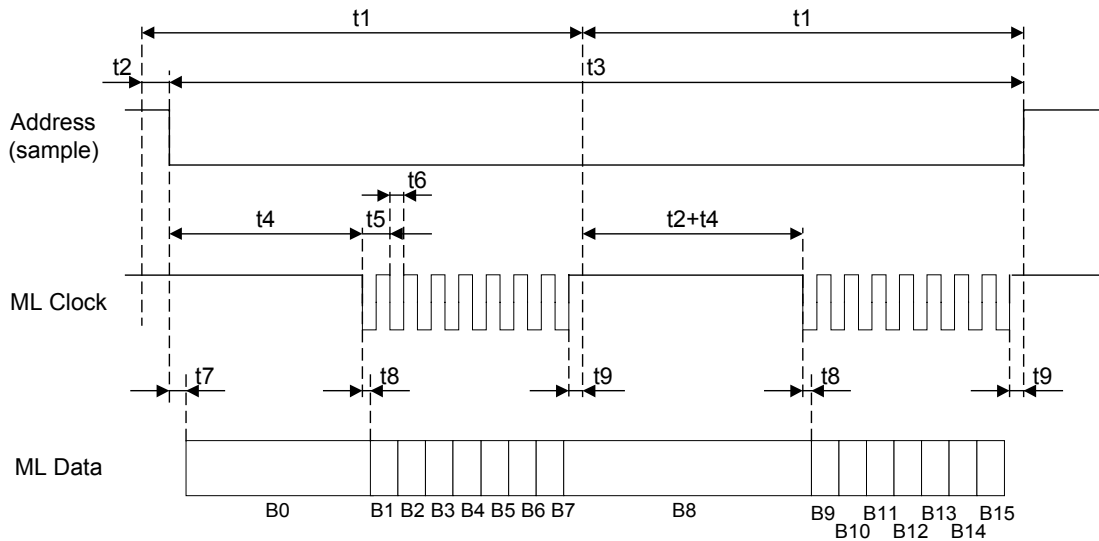

Figure 6-28 : ML16 command timing (B0 is MSB)

Timing requirements

	ML16
t1	64 t ± t
t2	4 t ± t
t3	124 t ± t
t4	28 t ± t
t5	4 t ± 0.1 t
t6	2 t ± 0.6 t
t7	< 4 t
t8	0.5 t to 2 t
t9	> 1.5 t

where $t = 2^{-20} s \approx 0.95 \mu s$

Table 6-19 : ML16 command timing requirement

Rise and fall times are valid for all three signal types: address, clock, and data.

The electrical characteristics of address, clock and data lines are as given for the SBDL (see paragraph 6.8.1.4)

GENERAL DESIGN AND INTERFACE REQUIREMENTS (GDIR)

REFERENCE : H-P-1-ASPI-SP-0027

DATE : 25-Nov-2003

ISSUE : 4.2 PAGE : 110/118

6.8.2 Telemetry Interfaces

6.8.2.1 Analogue telemetry

	SOURCE	RECEIVER
CIRCUIT TYPE	Single ended (or differential)	Differential Receiver
VOLTAGE - Differential - Common mode (return w.r.t receiver ground) - C.M.R.R	0 V < U < 5.12 V -2.5 V < U < 2.5 V	0 V < U < 5.12 V 60 dB up to 10 kHz falling 20dB/dec. up to 1MHz
IMPEDANCE - Differential (power ON) - Com. mode (power ON) - Com. mode (power OFF)	≤ 10 kΩ ≤ 100 kΩ	> 15 MΩ // < 1μF > 10 MΩ > 1kΩ // < 1μF
CAPACITANCE (differential)	50 nF ≤ C ≤ 1μF	< 1 μF (at input) < 100 pF (after MUX)
LEAKAGE CURRENT	to deal with a permanent load of 1 kΩ	< 500 nA (power ON) < 0.5 mA (power OFF)
FAULT VOLTAGE - Emission - Tolerance	-3 V < U < +14 V -16 V < U < +16 V (in series with ≥ 1.5 kΩ)	-16 V < U < +16 V (in series with ≥ 1.5 kΩ) -3 V < U < +14 V (1) (I < 16 mA when power OFF)
LINE CHARACTERISTICS Type Total Core to core Capacitance Total Core to shield Capacitance Total Voltage Drop	Twisted shielded 5 cores - AWG26 < 900 pF < 1.8 nF < 2 mV	

(1) shall not cause any damage, nor shall affect the performance of any other part than the concerned input.

Table 6-21 : Analogue telemetry interface characteristics

The A/D coding shall be achieved by using 12 bits.

GENERAL DESIGN AND INTERFACE REQUIREMENTS (GDIR)

REFERENCE : H-P-1-ASPI-SP-0027

DATE : 25-Nov-2003

ISSUE : 4.2 PAGE : 111/118

6.8.2.2 Thermistor acquisition

The measurement range for a "Fenwall - GB 42" thermistor (or an equivalent thermistor with the same resistance / temperature response curve) is [-40°C ; +85°C].

	SOURCE	RECEIVER
CIRCUIT TYPE	"Fenwall - GB 42" thermistor	Single ended Receiver
VOLTAGE AFTER THERMISTOR CONDITIONING (after resistor bridge)		0 V < U < 5.12 V (cod. range) --> LSB = 20 mV
IMPEDANCE Min, Max	15 kΩ at 25°C	depends on bridge resistances values
CAPACITANCE (differential)		< 1μF (at input) < 100 pF (after MUX)
THERMISTOR SELF POWER DISSIPATION < 0.05 W	Th. current < $\sqrt{\frac{0.05 W}{R_{min}}}$ Rmin = thermistor min. resist.	Voltage applied to thermistor < $\sqrt{0.05 W * R_{min}}$
FAULT VOLTAGE - Emission Tolerance	short circuit to mechanical ground -16 V < U < +16 V (in series with ≥ 1.5 kΩ)	-16 V < U < +16 V (in series with ≥ 1.5 kΩ) short circuit to mechanical ground (1)
LINE CHARACTERISTICS Type Total Core to core Capacitance Total Core to shield Capacitance	Twisted shielded pair - AWG26 < 900 pF < 1.8 nF	

(1) shall not cause any damage, nor shall affect the performance of any other part than the concerned input.

Table 6-23 : Thermistor acquisition interface characteristics

GENERAL DESIGN AND INTERFACE REQUIREMENTS (GDIR)

REFERENCE : H-P-1-ASPI-SP-0027

DATE : 25-Nov-2003

ISSUE : 4.2 PAGE : 112/118

6.8.2.3 Cryo-temperature and Solar Array temperature acquisition

The CDMU will be able to condition and acquire temperature sensors located at cryo temperatures and on the Solar Array with the following ranges and accuracy:

- Acquisition range 40K to 70K
 - Temperature Sensor Type: Rosemount 118 MF, 2000 $\Omega \pm 2\%$. Electrical interface characteristics are given in Table 6-25.
 - Accuracy (acquisition electronics without calibration) $\pm 1.0\text{ K}$
- Acquisition range 40K to 350K
 - Temperature Sensor Type: Rosemount 118 MF, 2000 $\Omega \pm 2\%$. Electrical interface characteristics are given in Table 6-25.
 - Accuracy (acquisition electronics without calibration) $\pm 2.5\text{ K}$
- Acquisition range 170 K to 440 K
 - Temperature Sensor Type: Rosemount 118 MF, 2000 $\Omega \pm 2\%$. Electrical interface characteristics are given in Table 6-25.
 - Accuracy (sensor + acquisition electronics) $\pm 4\text{ K}$

	SOURCE	RECEIVER
CIRCUIT TYPE	Platinum Probe (Rosemount 118 MF, 2000 $\Omega \pm 2\%$)	Single ended Receiver
IMPEDANCE Min, Max	(Typical: 2 k Ω at 0°C)	depends on bridge resistances values
CAPACITANCE (differential)		< 1 μF (at input) < 100 pF (after MUX)
THERMISTOR SELF POWER DISSIPATION < 0.05 W (1)	Th. current < $\sqrt{\frac{0.05\text{ W}}{R_{\min}}}$ Rmin = thermistor min. resist.	Voltage applied to thermistor < $\sqrt{0.05\text{ W} * R_{\min}}$
FAULT VOLTAGE - Emission Tolerance	short circuit to mechanical ground -16 V < U < +16 V (in series with $\geq 1.5\text{ k}\Omega$)	-16 V < U < +16 V (in series with $\geq 1.5\text{ k}\Omega$) short circuit to mechanical ground (2)
LINE CHARACTERISTICS Type Total Core to core Capacitance Total Core to shield Capacitance	Twisted shielded pair - AWG26 < 900 pF < 1.8 nF	

(1) power to thermistor to be applied only during acquisition to minimise self heating.

(2) shall not cause any damage, nor shall affect the performance of any other part than the concerned input.

Table 6-25 : Cryo-temperature acquisition interface characteristics

6.8.2.4 Digital relay status acquisition

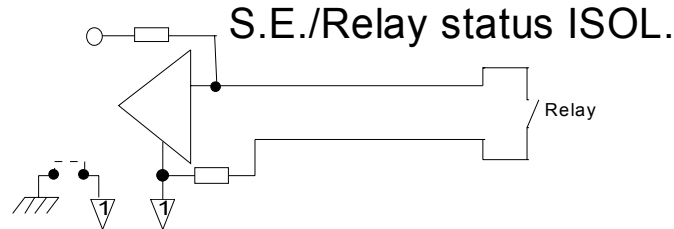

Figure 6-30 : Electrical scheme of a digital relay status acquisition line

The digital status information is presented by the user in the form of a contact resistance that can assume only two distinct values, a closed contact (logical "1" level) represented by a low resistance and an open contact (logical "0" level) represented by a high resistance, between the 2 digital status lines. Each digital status acquisition corresponds to one bit of the housekeeping telemetry format

	SOURCE	RECEIVER
CIRCUIT TYPE	Switch / Relay contact	Single ended Receiver with pull-up resistor
RESISTANCE / VOLTAGE		
- "0" level (open)	$R_s \geq 1 \text{ M}\Omega$	$V_{out} \geq 2.5 \text{ V}$ (max. threshold)
- "1" level (closed)	$R_s \leq 10 \Omega$	$V_{out} \leq 1.5 \text{ V}$ (min. threshold) ⁽²⁾
CURRENT	$< 10 \text{ mA}$	$0.1 \text{ mA} < I < 10 \text{ mA}$
VOLTAGE	contact capability $> 5.5 \text{ V}$	$V_{out} < 5.5 \text{ V}$
FAULT VOLTAGE		
- Emission	$-3 \text{ V} < U < +14 \text{ V}$	$-16 \text{ V} < U < +16 \text{ V}$ (in series with $\geq 1.5 \text{ k}\Omega$)
- Tolerance	$-16 \text{ V} < U < +16 \text{ V}$ (in series with $\geq 1.5 \text{ k}\Omega$)	$-3 \text{ V} < U < +14 \text{ V}$ ⁽¹⁾
LINE CHARACTERISTICS		
Type	Twisted (shielded) pair- AWG26	
Total Core to core Capacitance	$< 900 \text{ pF}$	
Total Core to shield Capacitance	$< 1.8 \text{ nF}$ (if shielded)	

(1) shall not cause any damage, nor shall affect the performance of any other part than the concerned input.

(2) V_{out} is the output voltage of the relay switch with associated pullups (so at receiver input).

Table 6-27 : Digital relay status acquisition interface characteristics

GENERAL DESIGN AND INTERFACE REQUIREMENTS (GDIR)

REFERENCE : H-P-1-ASPI-SP-0027

DATE : 25-Nov-2003

ISSUE : 4.2

PAGE : 114/118

6.8.2.5 Digital bi-level acquisition

Each bi-level digital channel is used to acquire one of a number of discrete status bits.

A digital bi-level channel consists of 2 lines.

The digital bi-level information is presented by the user in the form of a voltage that can assume only two distinct values, an "ON" level (logical "1" level) represented by a positive voltage and an "OFF" level (logical "0" level) represented by a zero voltage between the high bi-level source line and the low bi-level source line with the low bi-level source line as reference. Each digital bi-level acquisition corresponds to one bit of the housekeeping telemetry format.

At user level a single ended transmitter is allowed.



Figure 6-32 : Electrical scheme of a digital bi-level acquisition line

	SOURCE	RECEIVER
CIRCUIT TYPE	Single ended	Differential Receiver
VOLTAGE		
- "0" level (differential)	$0\text{ V} < U < 0.5\text{ V}$	$U < 2.5\text{ V}$ (max. threshold)
- "1" level (differential)	$3.5\text{ V} < U < 5.5\text{ V}$	$U > 1.5\text{ V}$ (min. threshold)
IMPEDANCE		
- Differential (power ON)	$\leq 10\text{ k}\Omega$	$> 15\text{ M}\Omega // < 1\mu\text{F}$
- Com. mode (power ON)		$> 10\text{ M}\Omega$
- Com. mode (power OFF)	$\leq 100\text{ k}\Omega$	$> 1\text{ k}\Omega // < 1\mu\text{F}$
CAPACITANCE (differential)	$50\text{ nF} \leq C \leq 1\mu\text{F}$	$< 1\mu\text{F}$ (at input) $< 100\text{ pF}$ (after MUX)
LEAKAGE CURRENT	to deal with a permanent load of $1\text{ k}\Omega$	$< 500\text{ nA}$ (power ON) $< 0.5\text{ mA}$ (power OFF)
FAULT VOLTAGE		
- Emission	$-3\text{ V} < U < +14\text{ V}$	$-16\text{ V} < U < +16\text{ V}$ (in series with $\geq 1.5\text{ k}\Omega$)
- Tolerance	$-16\text{ V} < U < +16\text{ V}$ (in series with $\geq 1.5\text{ k}\Omega$)	$-3\text{ V} < U < +14\text{ V}$ (1) ($I < 16\text{ mA}$ when power OFF)
LINE CHARACTERISTICS		
Type	Twisted (shielded) 5 cores - AWG26	
Total Core to core Capacitance	$< 900\text{ pF}$	
Total Core to shield Capacitance	$< 1.8\text{ nF}$ (if shielded)	
Total Voltage Drop	$< 2\text{ mV}$	

(1) shall not cause any damage, nor shall affect the performance of any other part than the concerned input.

Table 6-29 : Digital bi-level acquisition interface characteristics

6.8.2.6 Status Lines

Status lines may be used instead of the digital bi-level acquisition lines to provide digital telemetry.

The electrical interfaces shall be as defined for the SBDL see paragraph 6.8.1.4.

The duration of a status signal shall be > 10 ms.

6.8.2.7 Digital Serial Acquisition (DS16)

The purpose of the Serial Digital Acquisition link is to transfer a 8 or 16 bit data word, in serial form, from a particular user location on-board the satellite to a command distribution unit.

The interface consists of the following 3 signals :

- Sample

The user will be provided with a dedicated address line

- Clock

One Clock line is provided to each user. Clocks pulses are provided simultaneously to all users. 8 or 16 of these Clocks pulses are gated by the user with the Sample signal interval and used to control the shifting out of the 8 or 16 bits serial Data from the user. The Clock pulses have a known and reliable phase relationship with the NRZ-L Data transitions, thus ensuring reliable Data clocked out by the user and Data read-in by the command distribution unit.

- Data

One Data line is provided to each user. Selection of the user location is performed by means of the sample lines.

The Digital Serial Acquisition (DS/16) signals (Sample, Data, and Clock) shall comply with the interface requirements of the SBDL differential driver/receiver interface.

The DS16 acquisition timing shall be according to the figures below. The values specified are valid at the SBDL output when it is loaded with $1.2 \text{ nF} \parallel 10 \text{ k}\Omega$.

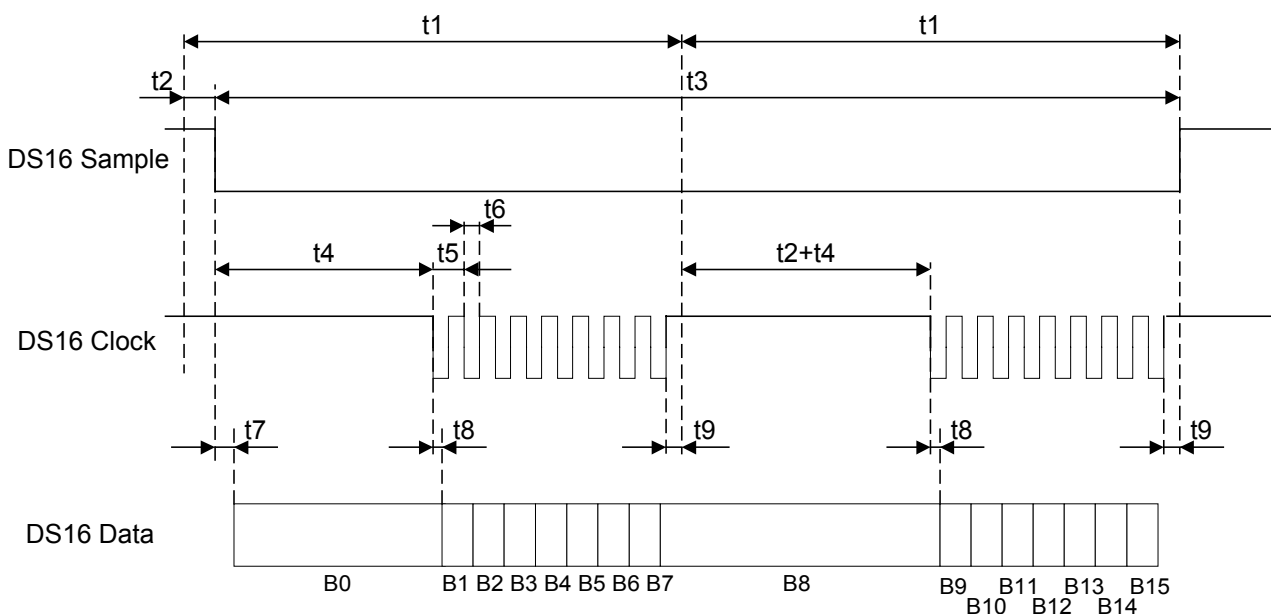

Figure 6-34 : DS16 acquisition timing (B0 is MSB)

	DS16
t1	64 t ± t
t2	4 t ± t
t3	124 t ± t
t4	28 t ± t
t5	4 t ± 0.1 t
t6	2 t ± 0.6 t
t7	< 16 t
t8	< 1.2 t
t9	> 1.5 t

where $t = 2^{-20} \text{ s} \approx 0.95 \mu\text{s}$

Table 6-31 : DS16 acquisition timing requirements

6.8.3 MIL-STD-1553B bus

Reference **GDEL-712 a**

The reference standard is MIL-STD-1553B Notice 2.

*

Reference **GDEL-715**

The bus users shall use the long stub configuration (transformer-coupled to the bus).

*

Reference **GDEL-720**

The MIL-STD-1553B bus connectors shall be dedicated (no sharing of connectors with any other signal) and segregated (one connector for nominal bus and one for redundant bus) on each unit using this bus.

*

Reference **GDEL-730**

Connectors shall preferably be 9 DBAS 70 3 0 S N 1A and 9 DBAS 70 3 0 S X 1A (for nominal and redundant MIL-STD-1553B bus lines).

*

If different, they shall be submitted to Satellite Contractor approval.

Reference **GDEL-740 a**

MIL-STD-1553B users shall conform to the bus protocol specified in AD- 41 Appendix 9.

GENERAL DESIGN AND INTERFACE REQUIREMENTS (GDIR)

REFERENCE : H-P-1-ASPI-SP-0027

DATE : 25-Nov-2003

ISSUE : 4.2 PAGE : 117/118

*

6.8.4 Timing and synchronisation

Reference **GDEL-745**

All timing and synchronisation signals shall use the SBDL interface as defined in paragraph 6.8.1.4.

*

Reference **GDEL-750 a**

A synchronisation signal derived from the on board master clock will be made available. It shall have the characteristics given in Table 6-33.

Frequency	131 072 Hz
Long Term Stability (1 month)	10^{-6}
Short Term Stability (100 s)	10^{-6}
Duty Cycle (% of 1/Frequency)	50 % \pm 10 %
Jitter	+/- 150 ns (nanoseconds)

Table 6-33 : Synchronisation signal characteristics

*

APPENDIX 1 : ICD TEMPLATE

The "ICD template" is distributed by Alcatel Space in Microsoft Word 97 .dot electronic format (not available in DOORS electronic format).

The use of this template is fostered, but not mandatory.

Instructions for using the ICD template

Put your logo instead of ALCATEL SPACE one.

The following fields shall be filled as following :

- <<ASPI Module Référence>> : ICD reference
- <<ASPI Module Date>> : date of issue of the ICD
- <<ASPI Module Issue>> : issue (and revision if necessary)
- <<ASPI module titre>> : Name_of_your_unit ICD
- <<ASPI module Code OT>> : product tree identifier (see RD-9)
- Data Management : add the name of the responsible in your company of the shipping of this ICD
- Entité émettrice (détentrices de l'original) : put the name of the premises where the original document is issued/stored. Ex: Alcatel Space - Cannes, or Alenia Spazio - Torino,...

- END OF THE DOCUMENT -

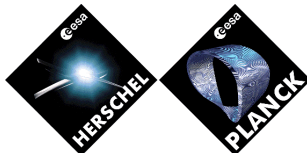

HERSCHEL / PLANCK

<<ASPI module titre>>

<<ASPI Module Référence>>

Product Code : <<ASPI module Code OT>>

Rédigé par/ <i>Written by</i>	Responsabilité-Service-Société <i>Responsibility-Office -Company</i>	Date	Signature
GDIR - Appendix 1: ICD template H-P-1-ASPI-SP-0027			
Verifié par/ <i>Verified by</i>			
Approbation/ <i>Approved</i>			

Data management :

Entité Emettrice :
(détentrice de l'original) :

<<ASPI MODULE TITRE>>

GDIR - Appendix 1: ICD template
H-P-1-ASPI-SP-0027

REFERENCE : <<ASPI Module
Référence>>

DATE : <<ASPI Module Date>>

ISSUE : <<ASPI
Module
Issue>>

PAGE : 2/19

DISTRIBUTION / DISTRIBUTION RECORD

HERSCHEL/PLANCK	DISTRIBUTION RECORD		
EXTERNAL DISTRIBUTION	For information For Application For Approbation For Action For Acceptation	INTERNAL DISTRIBUTION	
ESA	X		
ALCATEL SPACE	X		
		Clt Documentation	Orig.

<<ASPI MODULE TITRE>>

GDIR - Appendix 1: ICD template
H-P-1-ASPI-SP-0027

REFERENCE : <<ASPI Module
Référence>>

DATE : <<ASPI Module Date>>

ISSUE : <<ASPI
Module
Issue>>

PAGE : 3/19

ENREGISTREMENT DES EVOLUTIONS / *CHANGE RECORD*

ISSUE	DATE	§ : DESCRIPTION DES EVOLUTIONS § : <i>CHANGE RECORD</i>	REDACTEUR <i>AUTHOR</i>
1	07-Mar-2003	First issue of the ICD (Interface Control Document) template. Note that the ICD template includes the IDS (Interface Data Sheets) template.	I.Bénilan

<<ASPI MODULE TITRE>>

GDIR - Appendix 1: ICD template
H-P-1-ASPI-SP-0027

REFERENCE : <<ASPI Module
Référence>>

DATE : <<ASPI Module Date>>

ISSUE : <<ASPI
Module
Issue>>

PAGE : 4/19

TABLE OF CONTENTS

DISTRIBUTION / DISTRIBUTION RECORD	2
ENREGISTREMENT DES EVOLUTIONS / CHANGE RECORD	3
TABLE OF CONTENTS	4
1. SCOPE	5
2. DOCUMENTS	6
2.1 APPLICABLE DOCUMENTS	6
2.2 REFERENCE DOCUMENTS	6
3. FUNCTIONAL INTERFACE	7
3.1 FUNCTIONAL DESCRIPTION AND BLOCK DIAGRAM	7
3.2 INPUTS	7
3.3 OUTPUTS	7
4. MECHANICAL AND THERMAL INTERFACES	8
4.1 MECHANICAL & THERMAL IDS (INTERFACE DATA SHEET)	8
4.2 LAYOUT AND CONNECTORS DEFINITION	10
5. ELECTRICAL INTERFACES	11
5.1 ELECTRICAL IDS (INTERFACE DATA SHEET)	11
5.2 CONNECTOR LIST AND PIN ALLOCATION PER CONNECTOR	14
5.3 ELECTRICAL INTERFACES DEFINITION AND CHARACTERISATION (FOR EACH TYPE OF SIGNAL: POWER, TELECOMMAND, TELEMETRY, ANALOG, DIGITAL,...)	16

<<ASPI MODULE TITRE>>

GDIR - Appendix 1: ICD template
H-P-1-ASPI-SP-0027

REFERENCE : <<ASPI Module
Référence>>

DATE : <<ASPI Module Date>>

ISSUE : <<ASPI
Module
Issue>>

PAGE : 5/19

1. SCOPE

<<ASPI MODULE TITRE>>

GDIR - Appendix 1: ICD template
H-P-1-ASPI-SP-0027

REFERENCE : <<ASPI Module
Référence>>

DATE : <<ASPI Module Date>>

ISSUE : <<ASPI
Module
Issue>>

PAGE : 6/19

2. DOCUMENTS

2.1 Applicable documents

2.2 Reference documents

<<ASPI MODULE TITRE>>

GDIR - Appendix 1: ICD template
H-P-1-ASPI-SP-0027

REFERENCE : <<ASPI Module
Référence>>

DATE : <<ASPI Module Date>>

ISSUE : <<ASPI
Module
Issue>>

PAGE : 7/19

3. FUNCTIONAL INTERFACE

3.1 Functional description and block diagram

3.2 Inputs

3.3 Outputs

4. MECHANICAL AND THERMAL INTERFACES

4.1 Mechanical & Thermal IDS (Interface Data Sheet)

UNIT INTERFACE CHARACTERISTICS

UNIT DESIGNATION :			
TOTAL NUMBER :		IN OPERATION :	
		IN REDUNDANCY :	

MECHANICAL CHARACTERISTICS PER UNIT

DIMENSIONS ⁽¹⁾ [mm] (Baseplate = Length x Width <u>including mounting feet</u>)									
Length :		Width :		Diameter :		Height :			
MASS [kg] :		+/-							
CoM LOCATION [mm] in the Unit Reference Frame (Reference Hole, +Xu, +Yu, +Zu) ⁽¹⁾⁽⁶⁾ :									
X :		+/-		Y :		+/-		Z :	
INERTIA [kg.m ²] in the Unit CoM Reference Frame (CoM, +Xu, +Yu, +Zu) ⁽⁶⁾ :									
lxx	lxy	lxz	=				+/-		
lxy	lyy	lyz							
lxz	lyz	lzz							
MATERIAL OF HOUSING AND SURFACE FINISH ⁽⁵⁾ :									
CONTACT AREA									
Total contact area [cm ²]		=		% of baseplate area					
Roughness of contact area [micrometer RMS] :									
Baseplate surface flatness [mm] :					Baseplate surface finish :				
EIGENFREQUENCY [Hz] :		vs ⁽⁷⁾		TIGHTENING THICKNESS [mm] :					

THERMAL CHARACTERISTICS PER UNIT

BASEPLATE MATERIAL AND THICKNESS [mm] :			
SURFACE PROPERTIES :			
EMISSIONITY :		ABSORPTIVITY ⁽²⁾ :	
SPECIFIC AREAS ⁽¹⁾ :			
SPECIFIC HEAT [J/kg/°K] :			

QUALIFICATION TEMPERATURE LIMITS [°C]

GROUND OPERATIONS		GROUND STORAGE & TRANSPORT		OPERATING MODE		NON OPERATING MODE		START UP	
<u>IGO-MIN</u>	<u>IGO-MAX</u>	<u>IGS-MIN</u>	<u>IGS-MAX</u>	<u>IO-MIN</u>	<u>IO-MAX</u>	<u>INO-MIN</u>	<u>INO-MAX</u>	<u>ISU-MIN</u>	<u>ISU-MAX</u>

HEAT DISSIPATION [W] (give % of incertitude)

MODE ⁽⁴⁾	AVERAGE	MINI ⁽³⁾	MAXI ⁽³⁾

OBSERVATIONS

<<ASPI MODULE TITRE>>

GDIR - Appendix 1: ICD template
H-P-1-ASPI-SP-0027

REFERENCE : <<ASPI Module
Référence>>

DATE : <<ASPI Module Date>>

ISSUE : <<ASPI
Module
Issue>>

PAGE : 9/19

-
- (1) Precise with a drawing on the "Drawing (mechanical)" IDS (Page 2) the specific areas in case of various thermal coating (if any).
 - (2) Solar Absorptance only for locations outside of the satellite (which could be seen by the Sun).
 - (3) Give diagram on separated sheet $W = f(t)$ for each typical phase.
 - (4) Complete with special modes if any : state precisely relevant events.
 - (5) Including baseplate characteristics.
 - (6) The Unit Reference Frame (Reference Hole, +Xu, +Yu, +Zu) is defined in §4.1.2 of the GDIR. The Unit CoM Reference Frame (CoM, +Xu, +Yu, +Zu) results of the translation of the Unit Reference Frame from the Unit Reference Hole to the Unit Centre of Mass.
 - (7) Put the eigenfrequency requirement applicable to the unit.

<<ASPI MODULE TITRE>>

GDIR - Appendix 1: ICD template
H-P-1-ASPI-SP-0027

REFERENCE : <<ASPI Module
Référence>>

DATE : <<ASPI Module Date>>

ISSUE : <<ASPI
Module
Issue>>

PAGE : 10/19

4.2 Layout and connectors definition

DRAWING (mechanical)



On this drawing, indicate dimensions, inertia axes (CoM, +Xu), (CoM, +Yu), (CoM, +Zu), footprint, location of unit CoM, mounting points, diametric tolerance, centre to centre distance, position tolerance (guide pins or holes), location type orientation, necessary access after integration for calibration or test, bonding stud location and length and so on... Indicate also for the electrical connectors their No, their reference, their dimensions and their locations. Add as many pages "Drawing (mechanical)" as necessary.

<<ASPI MODULE TITRE>>

GDIR - Appendix 1: ICD template
H-P-1-ASPI-SP-0027

REFERENCE : <<ASPI Module
Référence>>

DATE : <<ASPI Module Date>>

ISSUE : <<ASPI
Module
Issue>>

PAGE : 11/19

5. ELECTRICAL INTERFACES

5.1 Electrical IDS (Interface Data Sheet)

ELECTRICAL POWER DEMAND - Maximum Average ¹

Phase ²	Mode ³	Power requested per unit [W]	Number of working units	Total power demand [W]

REMARKS :

¹ The "maximum average electrical power demand" is the maximum of the integrated average power demand in any period of 5 minutes excluding peak power. Detail "Total Power" and "Power per LCL".

² Precise the Mission Operation Phase (Launch phase, IOP, Commissioning Phase, Performance Verification Phase or Routine Operations Phase).

³ Complete with mode details for each phase, if necessary, and with special modes if any, stating precisely when they occur (eg: Instrument Operation Modes).

<<ASPI MODULE TITRE>>

GDIR - Appendix 1: ICD template
H-P-1-ASPI-SP-0027

REFERENCE : <<ASPI Module
Référence>>

DATE : <<ASPI Module Date>>

ISSUE : <<ASPI
Module
Issue>>

PAGE : 12/19

ELECTRICAL POWER DEMAND - Maximum Peak ¹

Phase ²	Mode ³	Peak type ⁴	Peak demand [W]	Duration	Repetition rate [1/s]	Occurrence of peak ⁵

REMARKS :

¹ Detail total power and power per LCL.
² Precise the Mission Operation Phase (Launch phase, IOP, Commissioning Phase, Performance Verification Phase or Routine Operations Phase).
³ Complete with mode details for each phase, if necessary, and with special modes if any, stating precisely when they occur (eg: Instrument Operation Modes).
⁴ Peak type : L - long peak, max. duration 5 min, maximum of the integrated mean demand in any period of 100 min.
S - short peak, max. duration 100 ms, maximum of the integrated mean demand in any period of 1 ms.
⁵ Describe when peak demand occurs.

<<ASPI MODULE TITRE>>

GDIR - Appendix 1: ICD template
H-P-1-ASPI-SP-0027

REFERENCE : <<ASPI Module
Référence>>

DATE : <<ASPI Module Date>>

ISSUE : <<ASPI
Module
Issue>>

PAGE : 13/19

GROUNDING SCHEME



<<ASPI MODULE TITRE>>

GDIR - Appendix 1: ICD template
H-P-1-ASPI-SP-0027

REFERENCE : <<ASPI Module
Référence>>

DATE : <<ASPI Module Date>>

ISSUE : <<ASPI
Module
Issue>>

PAGE : 15/19

PIN ALLOCATION ¹

CONNECTOR No.:		CONNECTOR TYPE ² :	
----------------	--	-------------------------------	--

PIN No.	Function	Type of line	Interface cabling requirement ³	Remarks

¹ Use one sheet per connector as connector.

² Give the complete connector manufacturer designation.

³ If there is a S/S requirement, then enter
TW : Twisted
BL : Bundled
SH : Shielded

<<ASPI MODULE TITRE>>

GDIR - Appendix 1: ICD template
H-P-1-ASPI-SP-0027

REFERENCE : <<ASPI Module
Référence>>

DATE : <<ASPI Module Date>>

ISSUE : <<ASPI
Module
Issue>>

PAGE : 16/19

5.3 Electrical interfaces definition and characterisation (for each type of signal: power, telecommand, telemetry, analog, digital,...)

TM INTERFACE (CIRCUITRY DIAGRAM)



<<ASPI MODULE TITRE>>

GDIR - Appendix 1: ICD template
H-P-1-ASPI-SP-0027

REFERENCE : <<ASPI Module
Référence>>

DATE : <<ASPI Module Date>>

ISSUE : <<ASPI
Module
Issue>>

PAGE : 17/19

TC INTERFACE (CIRCUITRY DIAGRAM)



<<ASPI MODULE TITRE>>

GDIR - Appendix 1: ICD template
H-P-1-ASPI-SP-0027

REFERENCE : <<ASPI Module
Référence>>

DATE : <<ASPI Module Date>>

ISSUE : <<ASPI
Module
Issue>>

PAGE : 18/19

POWER INTERFACE



<<ASPI MODULE TITRE>>

GDIR - Appendix 1: ICD template
H-P-1-ASPI-SP-0027

REFERENCE : <<ASPI Module
Référence>>

DATE : <<ASPI Module Date>>

ISSUE : <<ASPI
Module
Issue>>

PAGE : 19/19

TM/TC DEMAND SUMMARY

Format TBD

- END OF DOCUMENT -