



SPIRE & PACS
Sorption Coolers
Interface Control Document

DOC N°: HSO-SBT-ICD-012
Iss/Rev : 1.2
DATE : 31/07/2001
PAGE : i

SERVICE DES BASSES TEMPERATURES [CEA/DSM/DRFMC/SBT]

SPIRE & PACS Sorption Coolers
INTERFACE CONTROL DOCUMENT
(ICD)

SBT internal ref : SBT/CT/2001-24

	Name & Function	Date	Signature
Prepared	L. Duband - Cooler project manager		
SBT PA Check	P. Dupont – Cooler PA manager		
SPIRE Approval			
PACS Approval			
PA Approval	F. Loubere – PA manager		
Project Approval	J.L Augueres - SAp HSO project manager		
Project Approval	L. Duband - Cooler project manager		

Service des Basses Températures (SBT)
Département de Recherche Fondamentale sur la Matière Condensée (DRFMC)
COMMISSARIAT A L'ENERGIE ATOMIQUE - GRENOBLE (CEA-Grenoble)
17, rue des Martyrs 38054 GRENOBLE Cédex 9, France.



SPIRE & PACS
Sorption Coolers
Interface Control Document

DOC N°: HSO-SBT-ICD-012
Iss/Rev : 1.2
DATE : 31/07/2001
PAGE : ii

SERVICE DES BASSES TEMPERATURES [CEA/DSM/DRFMC/SBT]

Document Status

Issue	Revision	Date	Nb of pages	Modifications
0	0	10/04/2001	15	First draft
0	1	14/05/2001	-	Quality of 3D views and detailed drawings improved. Wiring reviewed
0	2	28/05/2001	-	Front page + various pages
1	0	06/06/2001	14	First Issue – various pages modified
1	1	11/06/2001	14	Page 5, 12, 13, 14.
1	2	31/07/2001		Page 6,7 : mechanical lowered to 50 N. Additional mass acceptable added



SPIRE & PACS
Sorption Coolers
Interface Control Document

DOC N°: HSO-SBT-ICD-012
Iss/Rev : 1.2
DATE : 31/07/2001
PAGE : iii

SERVICE DES BASSES TEMPERATURES [CEA/DSM/DRFMC/SBT]

Table of Contents

1	Scope of the document.....	1
2	Documents	2
2.1	Applicable documents.....	2
3	Functional description and block diagram.....	3
4	Mechanical interface.....	4
4.1	Cooler structure – SPIRE	5
4.2	Cooler structure - PACS.....	6
4.3	Heat switches.....	6
4.4	Evaporator cold end	7
4.5	Electrical connector	9
5	Thermal interface.....	10
5.1	Cooler structure	10
5.2	Heat switches.....	10
5.2.1	Sorption pump heat switch	11
5.2.2	Evaporator heat switch	11
5.3	Evaporator cold tip.....	11
6	Electrical interface.....	12
7	Appendix – General interface drawing.....	14



SPIRE & PACS
Sorption Coolers
Interface Control Document

DOC N°: HSO-SBT-ICD-012
 Iss/Rev : 1.2
 DATE : 31/07/2001
 PAGE : iv

SERVICE DES BASSES TEMPERATURES [CEA/DSM/DRFMC/GBT]

List of Acronyms

AD	Applicable Document		
CEA	Commissariat à l' Energie Atomique		
CDR	Critical Design Review	Revue de conception détaillée	RCD
CQM	Cryogenic Qualification Model		
EV	Evaporator		
FIRST	Far Infrared and Submillimetre Telescope		
FS	Flight spare		
HSE	Heat Switch (on evaporator)		
HSP	Heat Switch (on sorption pump)		
N/A	Not Applicable		
PACS	Photoconductor. Array Camera and Spectrometer		
PFM	ProtoFlight Model		
RD	Reference Document		
SAP	Service d'Astrophysique		
SBT	Service des Basses Températures		
SCO	Sorption Cooler (full unit)		
SP	Sorption pump		
SPIRE	Spectral & Photometric Imaging Receiver		
SST	Support Structure		
TS	Thermal Shunt		
TSES	Thermal Strap to Evaporator Switch		
TSPS	Thermal Strap to Pump Switch		



SPIRE & PACS
Sorption Coolers
Interface Control Document

DOC N°: HSO-SBT-ICD-012
Iss/Rev : 1.2
DATE : 31/07/2001
PAGE : 1

SERVICE DES BASSES TEMPERATURES [CEA/DSM/DRFMC/SBT]

1 Scope of the document

This document defines the various interfaces between the ^3He sorption cooler and the SPIRE and PACS instruments. It comprises the mechanical, thermal and electrical interfaces. Both instruments share the same cooler design and consequently all interfaces are designed to be compatible.



SPIRE & PACS
Sorption Coolers
Interface Control Document

DOC N°: HSO-SBT-ICD-012
Iss/Rev : 1.2
DATE : 31/07/2001
PAGE : 2

SERVICE DES BASSES TEMPERATURES [CEA/DSM/DRFMC/SBT]

2 Documents

2.1 Applicable documents

All Applicable Documents are listed in the AD chapter of the CIDL (HSO-SBT-LI-010).

3 Functional description and block diagram

The cooling of the SPIRE and PACS detectors down to 300 mK will be effected by helium three sorption coolers. Both instruments share the same cooler design and thermal architecture. For each the cooler is mounted off a 4 K structure with two thermal straps connected to the superfluid helium cryostat. The temperature of the cryostat and of the structure are referred as respectively Level 0 and Level 1. This thermal architecture is represented on the figure below.

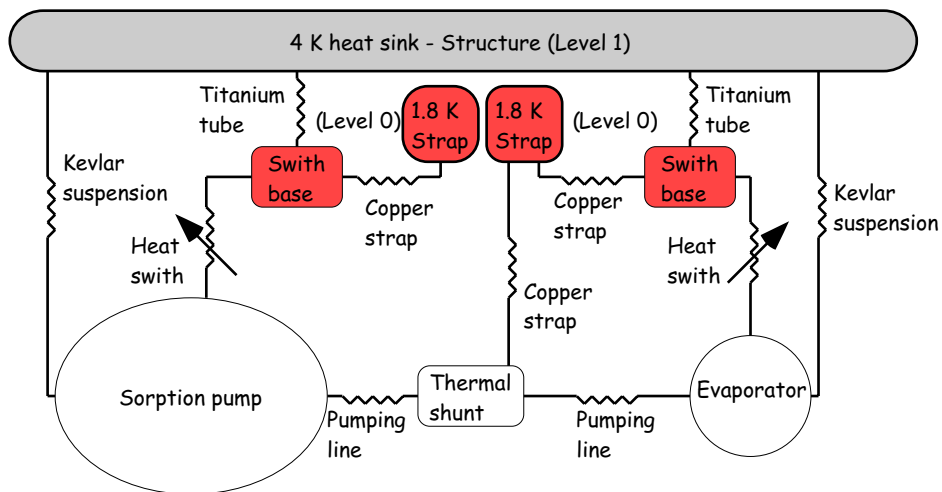

Thermal architecture

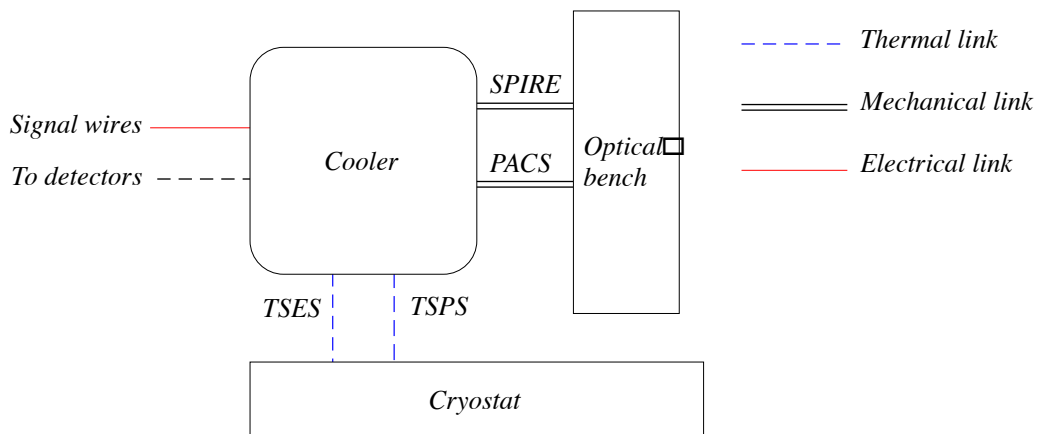

Block diagram

4 Mechanical interface

The cooler required volume is a rectangle parallelepiped of dimensions 228.5 mm x 100 mm x 100 mm. Reference drawing : 2000-14 B 000. **Throughout this document, unless otherwise specified, all dimensions are in millimeters.** The total overall mass of the cooler is about 1680 grams.

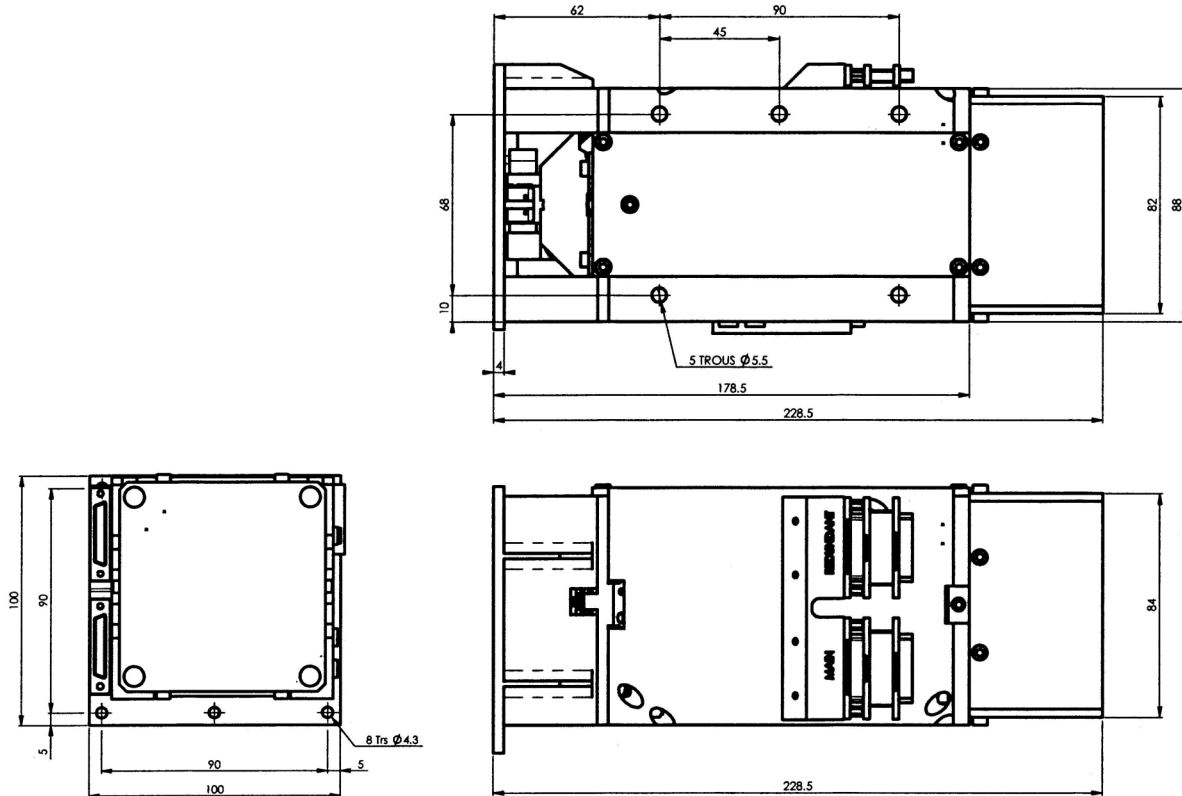

Cooler overall dimensions

For the purpose of this discussion the top, bottom and sides of the cooler are defined as represented on the figure below.

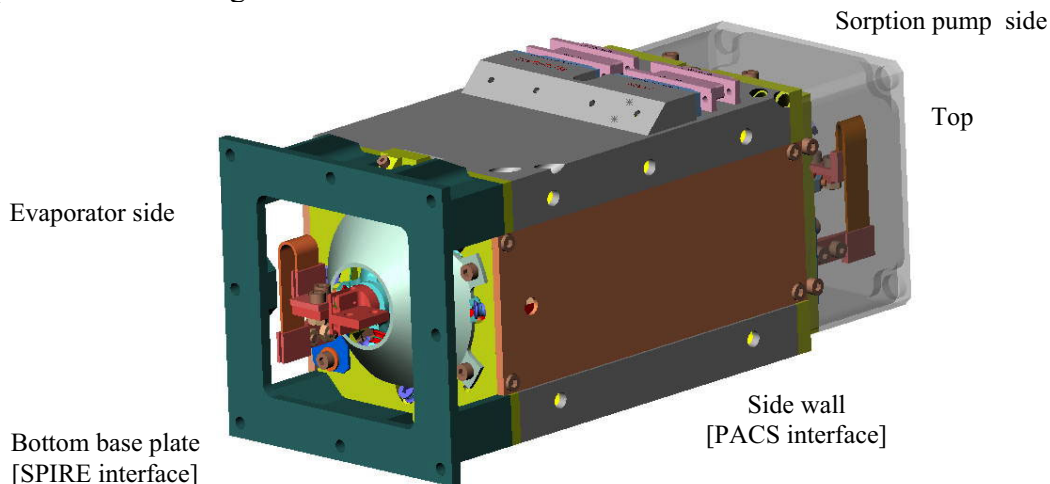

4.1 Cooler structure – SPIRE

Within the SPIRE instrument the cooler is mounted off an end flange as illustrated below. The cooler interfaces with the structure with 8 through holes 4.5 mm in diameter located on the 100 mm x 100 mm bottom base plate, as defined on the following drawings.

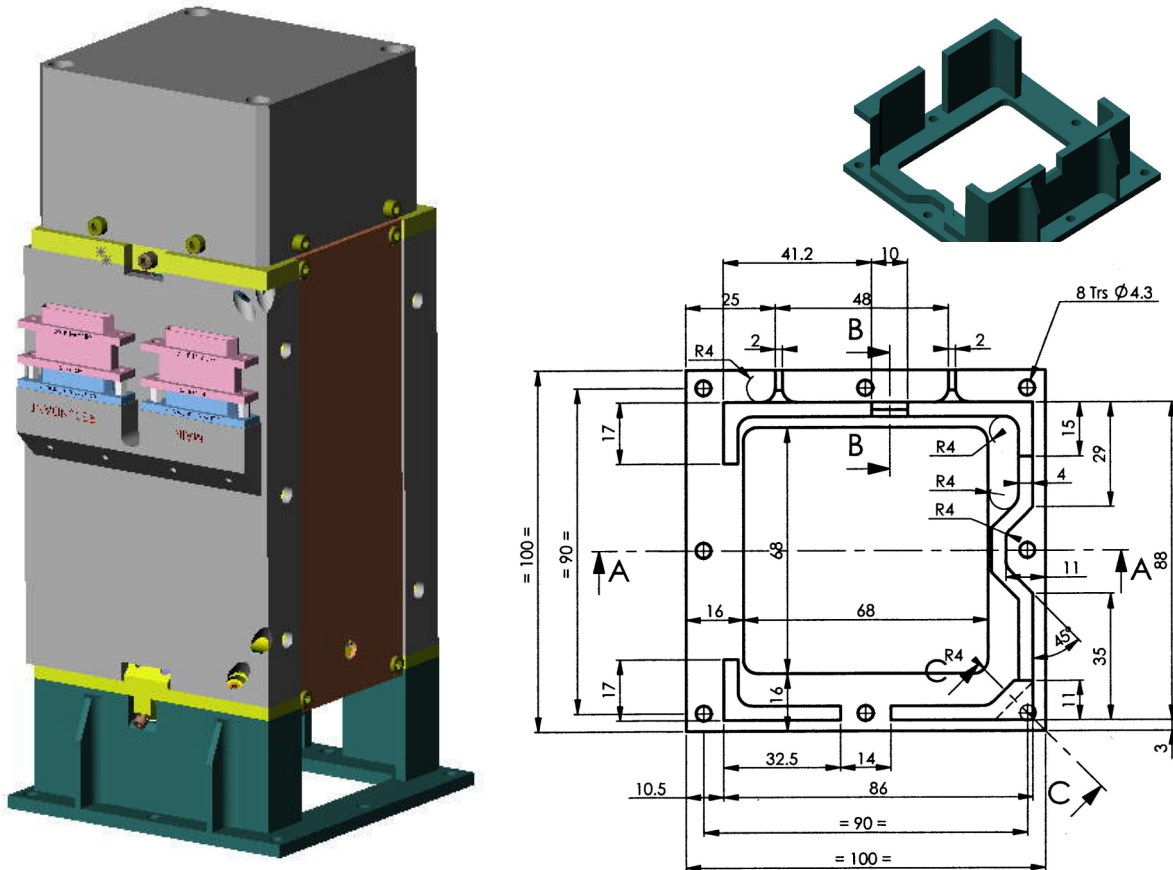

3D view and interface drawing for cooler mounting

In addition the top cover features four holes as shown on the figure hereafter. Part (or all) of these holes will be used as snubber(s): within SPIRE some extension is foreseen which insert in these holes after the cooler is mounted, to prevent any excessive lateral motion.

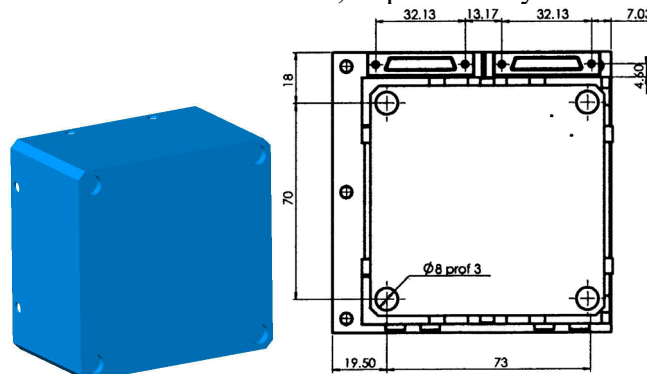

3D view and interface drawing for top cover (sorption pump)

4.2 Cooler structure - PACS

Within the PACS instrument the cooler is mounted along one of its side. The cooler interfaces with the structure with 5 through holes 5.5 mm in diameter located on one of the side wall as defined on the following drawing.

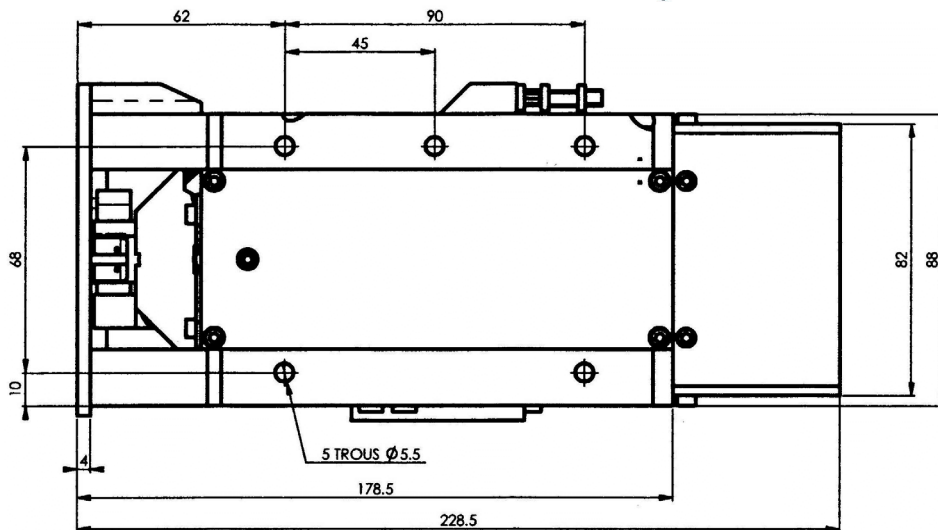
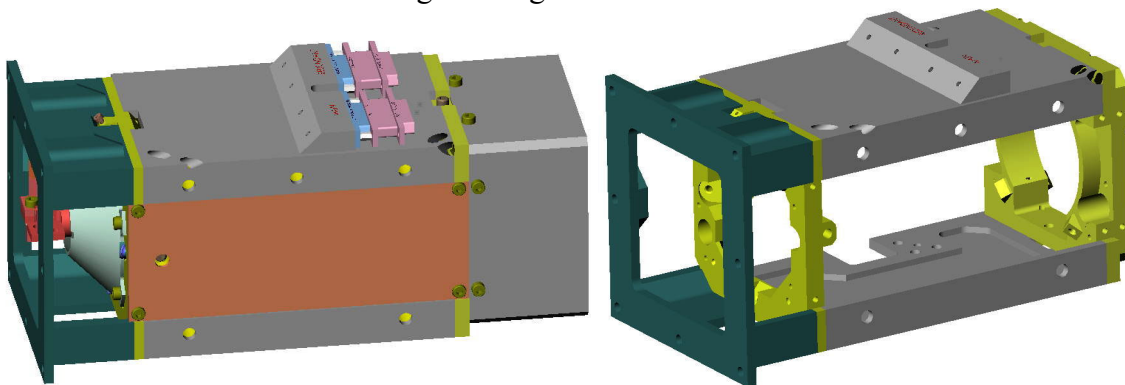

3D view and interface drawing for cooler mounting

4.3 Heat switches

The cooler comprises two gas gap heat switches located inside the structural box. The box then features two cut to provide access to the switch interface. Each heat switch interfaces with a thermal strap (connected to the superfluid cryostat). The mechanical interface for both switches is similar and is a copper plate gold plated 16 mm x 16 mm featuring two M3 holes (helicoil screw lock type). The maximum recommended torque for the screws is 0.33 Nm. The maximum additional mass which can be supported is 50 grams. This interface also features a tool designed to prevent any excessive torque on the gas gap heat switch when mounting the thermal strap. **This tool is intended to be used only while screwing the strap and must be removed before cooler operation – the drawing hereafter shows this tool in place.**

It is important to note that any excessive mechanical load on this interface must be avoided and shall in any case never exceeds 50 N in any directions.

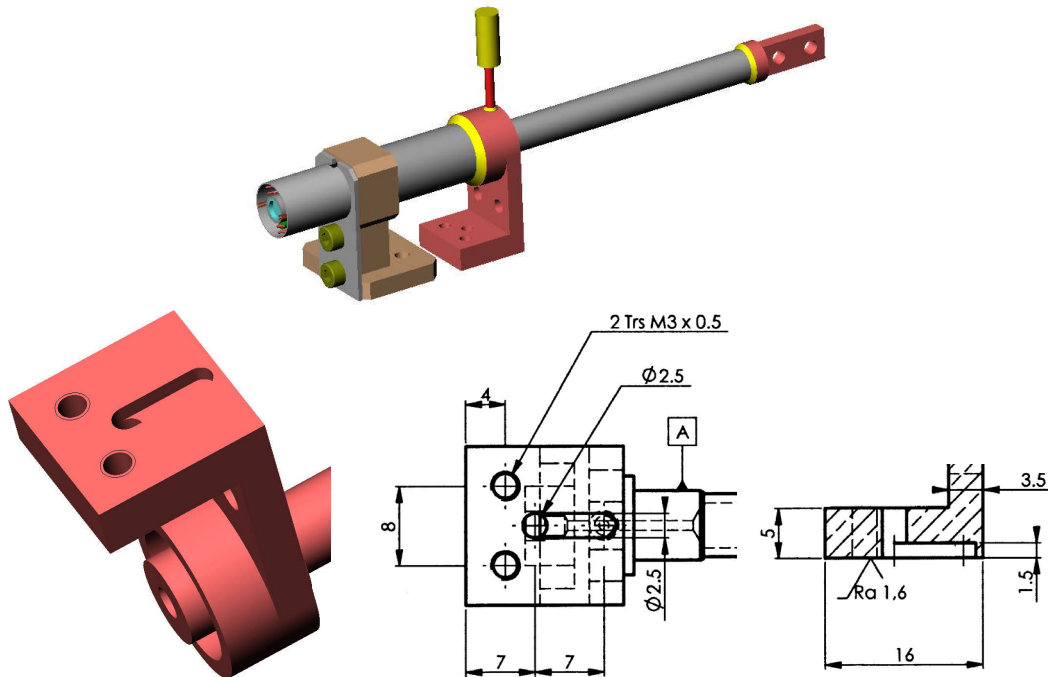

3D view and interface drawing for heat switch base / thermal strap

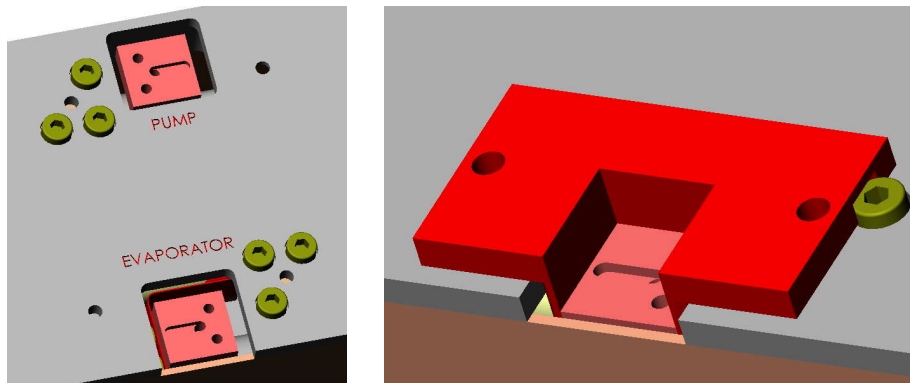

3D view of interface without and with mounting tool

4.4 Evaporator cold end

The evaporator cold end interfaces with a 300 mK thermal strap which is then split into two and connected to the detectors. This interface is a copper piece gold plated 14 mm x 12.5 mm, 3 mm thick, featuring two through holes 3.2 mm in diameter. Each side of the copper piece is available as a contacting area. The maximum recommended torque for the screws is 0.33 Nm.

- 1. The quality of this interface is critical to the performance of the cooler**
- 2. Any excessive torque or bending force on this interface must be avoided. Always use two wrenches (one on each side) when tightening screws on the cold head**
- 3. The mounting of the 300 mK thermal strap to the cold end must be performed by trained people. A specific procedure will be established.**

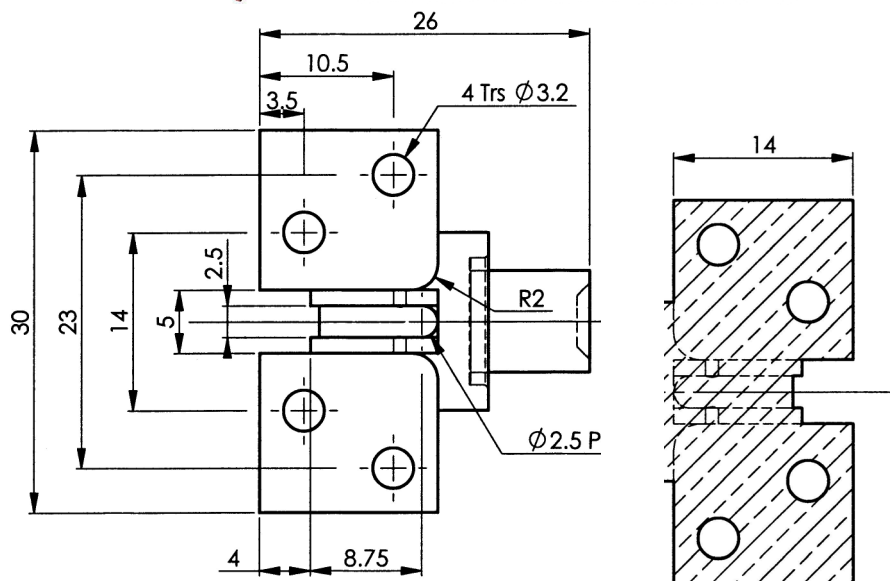
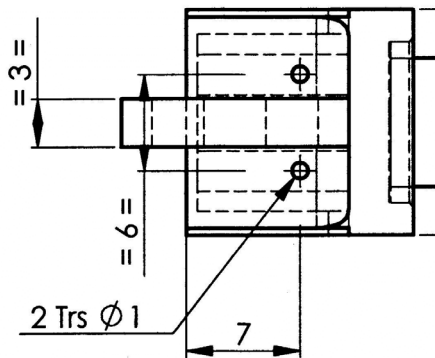
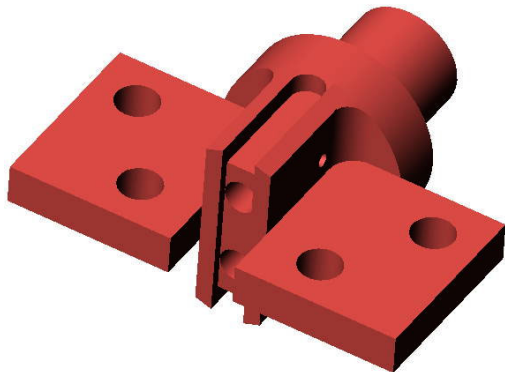
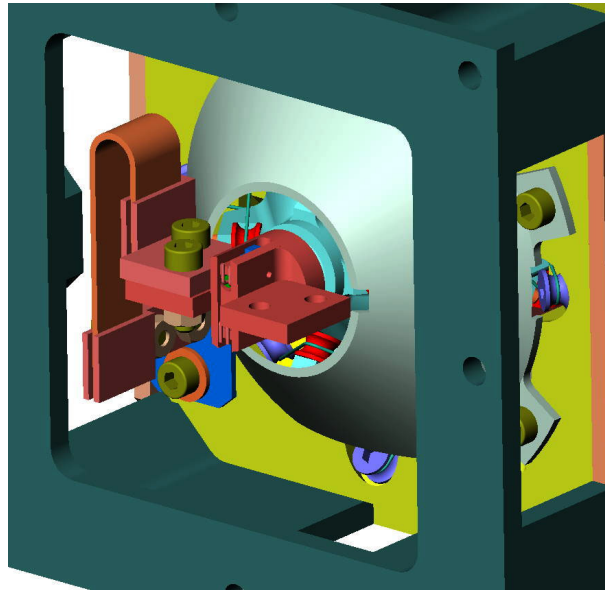

3D view and interface drawing for evaporator cold end / 300 mK thermal strap

4.5 Electrical connector

Two electrical connectors type MDM 37 pins female type (S) (main and redundant) are provided for the cooler operation. These connectors are supported by a bracket included in the structural box and located on the side of the cooler as shown on the following drawing.

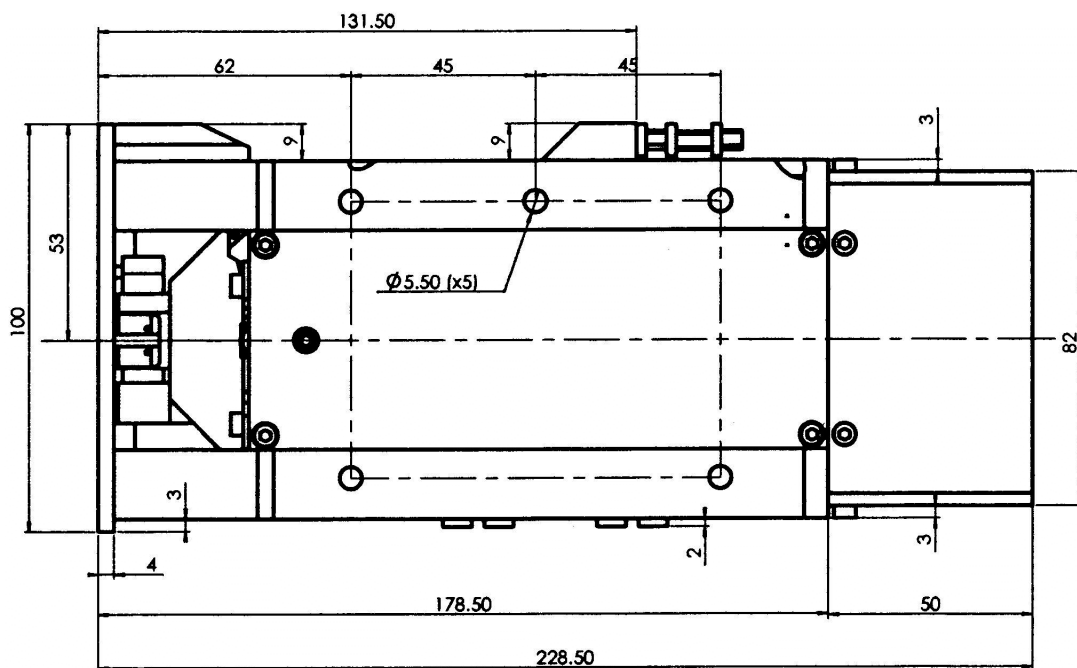
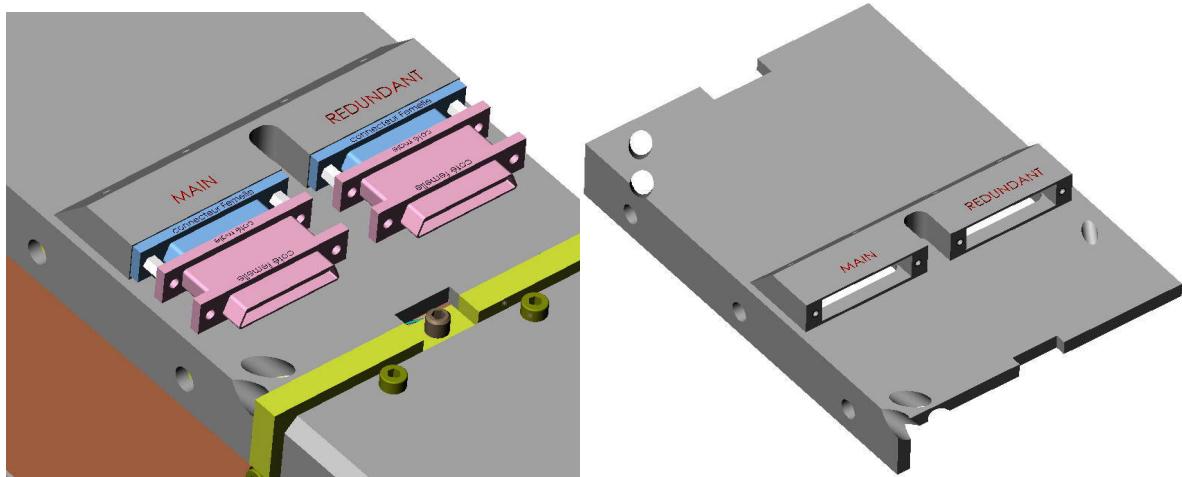

3D view and interface drawing for connector / connector



SPIRE & PACS Sorption Coolers Interface Control Document

DOC N°: HSO-SBT-ICD-012
Iss/Rev : 1.2
DATE : 31/07/2001
PAGE : 10

SERVICE DES BASSES TEMPERATURES [CEA/DSM/DRFMC/SBT]

5 Thermal interface

Informations of the mechanics of the thermal interfaces are given in the previous paragraphs. In these paragraphs, we define only the interfaces from the thermal point of view.

The maximum storage or handling temperature for the cooler is 353 K (80 °C). There is no minimum storage temperature.

The thermal interfaces are defined in functional conditions. Thermal operation of the cooler can be described as three phases :

- a condensation phase during which the sorption is heated to 40-45 K and liquid is condensed in the evaporator
- a cooldown phase during which the sorption pump is cooled back down and the condensed liquid is pumped down (cooling effect)
- a low temperature phase during which the cooler is providing cooling for the detectors

5.1 Cooler structure

The cooler structure is mounted to the instruments which are at a nominal temperature of 4K (plate at Level 1). This plate interface does not provide any real thermal functionality for the cooler. The mounting area, number of screws and heat flows are such no thermal problem are expected in the sense that the cooler structural box will remain at the temperature of the plate during all phases.

(However the temperature of the plate has a strong impact on the cooler performance as discussed in the technical note “Discussion on 4 liters versus 6 liters STP unit & ultimate temperature improvment” – TNS2).

We have indicated in the table below the various estimated heat flows during the different phases.

Table : Heat flow at cooler structure interface

<i>Phase</i>	<i>Condensation</i>	<i>Cooldown</i>	<i>Low temperature</i>
<i>Max. ΔT acceptable with plate</i>	1 K	1 K	0 K
<i>Maximum heat flow</i>	≤ 5 mW	≤ 5 mW	Close to 0

5.2 Heat switches

The cooler comprises two identical gas gap heat switches. They both interface with a strap (one each) thermally connected to the superfluid tank (Level 0 – Herschel cryostat). The two straps can be different due to the difference in power flowing to the cryostat from one strap to the other (see hereafter).

The interface with the switch to the sorption pump (TSPS) is less critical as it is possible to have this interface temperature raise to 10 K during recycling.

On the contrary the interface to the evaporator switch has a significant impact on the performance. During the recycling process this interface must be kept as close as possible to the cryostat temperature to guarantee good condensation efficiency, minimal cooldown losses, etc... for the cooler. However it is important to note that what matters is the evaporator



SPIRE & PACS
Sorption Coolers
Interface Control Document

DOC N°: HSO-SBT-ICD-012
Iss/Rev : 1.2
DATE : 31/07/2001
PAGE : 11

SERVICE DES BASSES TEMPERATURES [CEA/DSM/DRFMC/SBT]

temperature at the end of the condensation phase, i.e. a slight increase (few tenths of K) of the interface temperature is acceptable at the beginning of the recycling phase.

The tables hereafter display the estimated heat flows at various locations during the different phases.

5.2.1 Sorption pump heat switch

(related to TSPS)

Table : Heat flow at sorption pumpsnl heat switch interface

<i>Phase</i>	<i>Condensation</i>	<i>Cooldown</i>	<i>Low temperature</i>
<i>Maximum temperature acceptable</i>	N/A	10 K	5 K
<i>Maximum heat flow</i>	≤ 10 mW	≤ 1 W	≤ 2 mW*
<i>Suggested strap conductance</i>	10 mW/K		

(* : this number is a function of the detectors dissipation)

5.2.2 Evaporator heat switch

(related to TSES)

Table : Heat flow at evaporator heat switch interface

<i>Phase</i>	<i>Condensation</i>	<i>Cooldown</i>	<i>Low temperature</i>
<i>Maximum temperature acceptable</i>	2.8 K	2 K	2 K
<i>Maximum heat flow</i>	50 mW	≤ 15 mW	≤ 1 mW
<i>Suggested strap conductance</i>	≥ 75 mW/K		

5.3 Evaporator cold tip

The evaporator cold tip thermally interfaces with the detectors via a strap. The thermal capability of the cold tip is pretty much defined through its geometrical characteristics, material and surface quality (see & 4.4). The contact resistance with the strap is certainly a strong driver and all precaution must be taken to minimise this contact resistance.



SPIRE & PACS
Sorption Coolers
Interface Control Document

DOC N°: HSO-SBT-ICD-012
 Iss/Rev : 1.2
 DATE : 31/07/2001
 PAGE : 12

SERVICE DES BASSES TEMPERATURES [CEA/DSM/DRFMC/SBT]

6 Electrical interface

Two electrical Canon connectors type MDM 37 pins female type (S) are used, one prime and one redundant. The wiring of both connectors is identical. The pins out is arranged such that each set of wires per component is grouped (see table below). This is best seen on the schematics hereafter. All wiring is made using manganin wires, twisted by pair. The electrical isolation between any pin at the cooler interface and the cooler heart shall be > 10MOhms and < 5pF.

Signal	Pin n°	Max. current	Max. Ohms
SP temperature I+ (Drive)	20	1 μ A	1000
SP temperature V+ (Sens)	1	N/A	1000
SP temperature V- (Sens Return)	2	N/A	1000
SP temperature I- (Return)	21	1 μ A	1000
Shield SP temperature	3	N/A	N/A
EV temperature I+ (Drive)	22	250 nA	30 000
EV temperature V+ (Sens)	4	N/A	30 000
EV temperature V- (Sens Return)	5	N/A	30 000
EV temperature I-(Return)	23	250 nA	30 000
Shield EV temperature	24	N/A	N/A
HSP pump temperature I+ (Drive)	25	1 μ A	1000
HSP pump temperature V+ (Sens)	6	N/A	1000
HSP pump temperature V- (Sens Return)	7	N/A	1000
HSP pump temperature I-(Return)	26	1 μ A	1000
Shield HSP temperature	8	N/A	N/A
HSE pump temperature I+ (Drive)	27	1 μ A	1000
HSE pump temperature V+ (Sens)	9	N/A	1000
HSE pump temperature V- (Sens Return)	10	N/A	1000
HSE pump temperature I-(Return)	28	1 μ A	1000
Shield HSE temperature	29	N/A	N/A
Thermal shunt temperature I+ (Drive)	30	1 μ A	1000
Thermal shunt temperature V+ (Sens)	11	N/A	1000
Thermal shunt temperature V- (Sens Return)	12	N/A	1000
Thermal shunt temperature I-(Return)	31	1 μ A	1000
Shield Thermal shunt temperature	13	N/A	N/A
SP heater I+ (Drive)	14	25 mA	500
SP heater I+ (Drive)	32	“	500
SP heater I- (Return)	15	“	500
SP heater I- (Return)	33	“	500
HSE heater I+ (Drive)	16	1.5 mA	500
HSE heater I+ (Drive)	34	“	500
HSE heater I- (Return)	17	“	500
HSE heater I- (Return)	35	“	500
HSP heater I+ (Drive)	18	1.5 mA	500
HSP heater I+ (Drive)	36	“	500
HSP heater I- (Return)	19	“	500
HSP heater I- (Return)	37	“	500

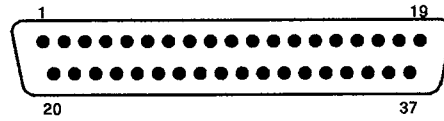

37 CONTACTS

Contact arrangement for MDM 37 pins

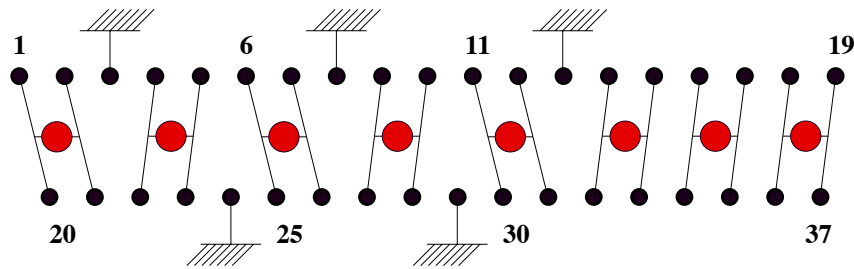

Connector wiring (red dot features thermometer or heater)

All thermometers used are Cernox thermometers type 1030 with SD package (supplier : LakeShore) measured in four wires mode. Typical resistance versus temperature curves are given hereafter.

All heaters used are high reliability metal film resistors 402 Ohms resistance driven by four wires (supplier : Vishay/Sfernice. Reference : 4001005-01B 4020F4 (high reliability resistance RLR05/2H3 402R 1/8W +/-100ppm 1% 200V)).

Cernox™ Temperature Sensor Response Curves

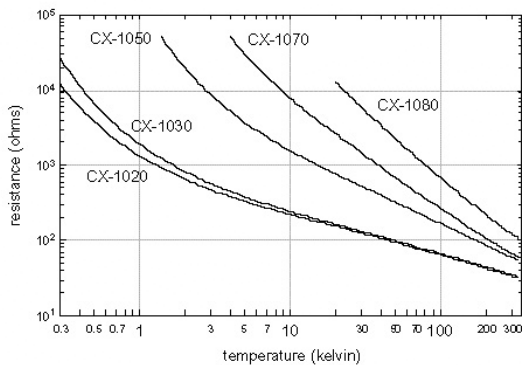

Figure 1. Typical resistance versus temperature response for the Cernox™ family of resistance temperature sensors.

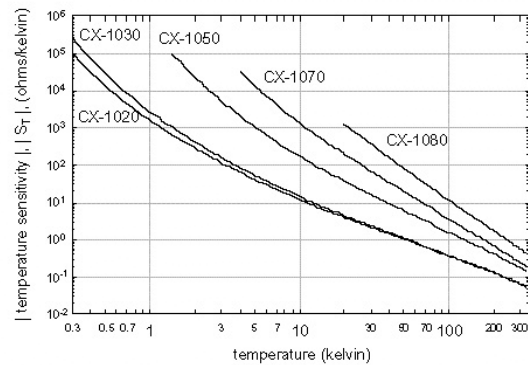

Figure 2. Typical temperature sensitivity (S_T) versus temperature response for the Cernox™ family of resistance temperature sensors.



SPIRE & PACS Sorption Coolers Interface Control Document

DOC N°: HSO-SBT-ICD-012
Iss/Rev : 1.2
DATE : 31/07/2001
PAGE : 14

SERVICE DES BASSES TEMPERATURES [CEA/DSM/DRFMC/SBT]

7 Appendix – General interface drawing

