



SPIRE
INSTRUMENT BLOCK DIAGRAM

Doc #: SPIRE-RAL-DWG-000646
Issue: 5.2
Date: 14th February 2003
Page 1 of 8

Subject: **SPIRE BLOCK DIAGRAM**

PREPARED BY: J. DELDERFIELD **Date:**

APPROVED BY: K. KING..... **Date:**



SPIRE
INSTRUMENT BLOCK DIAGRAM

Doc #: SPIRE-RAL-DWG-000646
Issue: 5.2
Date: 14th February 2003
Page 2 of 8

CHANGE RECORD

ISSUE	DATE	CHANGE(S) MADE
2.0	7/6/01	First Controlled Issue after IIDR
2.1	18/6/01	Deleted S/C Synchronisation. Added Master Clock Lines Split FCU into Modules, avoiding mixing Prime and Redundant connections via same motherboard, and requiring BSM module to be split Prime/Redundant, TBC. Re-ordered signal channels into harnesses to get breaks between BDAs to better align with LIA divisions. Removed last vestiges of showing Fast and Slow I/Fs separately as they are linked by W1-W6. Fix FCU J26 duplication.
2.2	29/6/01	Put BDA connector numbers in line with JPL's that indicate which of the six geometric positions are used. Bundle back-harness wires as per JPL diagram. Define LCL names.
2.3	7/7/01	Rearrange JFETs to stress "modularity"
2.4	7/8/01	Increase FCU J21 and J22 to 25way...to take calibrator heater wires that were omitted. Swop JFETs to using 37way filters with partially populated contacts.
2.5	8/8/01	Put in FPU clamshell connectors as harness name "breaks". Delete TBD.
2.6	7/9/01	Update SMEC connectors on FPU from 50 way to 2x37way each side.
2.7	9/10/01	Put in fully updated HSFCU
2.8	12/10/01	Correct way I harness tails split on to FCU...in error in version 2.7 Remove branch from F12A and route 300mK temperature "detectors" via HSJFS J7 AND J8 and new F 28. Correct PMW BDA Allocation. Add note to F20 and F21 so clear that each has one "Cernox" that is actually a 300Mk heater. Put in HSDCU with connectors drawn to scale.
2.9	18/10/01	Correct errors with W3-6 labels that crept into issue 2.8
3.0	30/10/01	Swop numbers on connector lines for DCU redundant bias generator so they fit with harness definition document, and connectors 29-34 remain if generators were to be put on one module or otherwise reconfigured.
3.1	31/10/01	Remove Filter Modules from JFET racks, thus adopting JPL's intention to use filter connectors and spliced harness.
3.2	9/11/01	Reduce HSDCU Bias module front panel sizes and house them in one double sided module. Call S4 T1 as per Doug's drawings.
3.3	21/11/01	Add last few connector IDs to JFET racks.
3.4	11/12/01	Got J1-J4 on FCU the correct way around [SCU to MCU!]
3.5	18/12/01	Move Connectors around on HSFPU to match CEA's v0.5 HSFPU ICD. Keep JTAG connectors shown elsewhere in DRCU ICD/Spec..but renumber as



SPIRE
INSTRUMENT BLOCK DIAGRAM

Doc #: SPIRE-RAL-DWG-000646
Issue: 5.2
Date: 14th February 2003
Page 3 of 8

		<p>J37 and J38</p> <p>Combine HSFCU SCU's DPU I/F and Cooler/Stimulus Modules</p> <p>Re-jig Shutter DRCU connectors to not be wired via HSFCU Modules</p> <p>Reduce J25/J26 Connector sizes as moving shutter wiring removes some pins from them.</p> <p>Change 1553 buses to A & B rather than Prime & Redundant</p> <p>Change J23 and J24 sizes because of HSFCU PCB frame restrictions.</p> <p>Move HSFCU Connectors to be in correct physical layout.</p> <p>Add J29 and J30 to shutter wiring to accommodate non-shutter launch latch confirm inputs. Change J15 and J16 to 25way as Doug's given the shutter more wires.</p> <p>Change HSFCU Shutter J17 and J18 to 21way MDM to match.</p> <p>Show power links on DRCU unit because these are not internal.</p> <p>Update HSDCU Bias connectors J29/32 to use 78-way HD triple row connectors after their acceptance by ESA.</p>
3.6	20/12/01	Frederic's comments on J22 and 3TCs implemented.
3.7	1/1/02	HSFCU Duplicate J29/30 Fixed, bumping numbers for JTAGs
3.8	1/2/02	Change SCAL 21 ways to 37 ways.
3.9	25/2/02	As per Passvogel decision, put four "skin" connectors on cryostat associated with cryoharnesses 10-13, to act as access points for EGSE for shutter operation and latch confirmations. Bracket on side of HSFCU deleted, and links to HCDMU's RTUs.
		As HERSCHEL latest accommodation, add connector plate on top of SVM and change cryoharness to include extra/extended/external "E" sections, which are all 1:1 with CVV wall connectors to minimise external RF. loops (except skin connector functions as per above change). "I" harnesses become copper for flight.
		Rationalise sex/sizes of HSFCU internal power connectors
4.0	5/3/02	Route 300 mk temperature control via Harness 2 and not Harness 1 due to needing to keep spare pins on CVV connectors.
		Optimise alignment of drawing
4.1	12/4/02	Correct HSFCU J9/10 & 31-36 shell size as per SVM meeting
4.2	22/4./02	Change E harness category to I and I harness category to S(SVM) to be the same as PACS and HIFI.
		Add caveat about using this diagram as a harness definition diagram
		Show which one of each pair of cryoharness in-line connectors are chassis mounted by adding P/J notes along I/F lines
		Include representation of 300mK cooling busbar and move 300mK sensor/heater unit to show how it links into F harnesses. Call this sub-system HSPTC (Photometer Temperature Control).
		Move EGSE break-out connectors from CVV skin to SCM connector panel as Astrium design implements.
4.3	15/5/02	Corrected one of two J33s to J34 on HSJFP
		Updated BDA Nanonics J numbers...which define their positions
		Move J22 link to SVM panel rather than in air above HSDCU.
4.4	1/6/02	Remove connectors on SME because unfortunately only flying leads can be



SPIRE
INSTRUMENT BLOCK DIAGRAM

Doc #: SPIRE-RAL-DWG-000646
Issue: 5.2
Date: 14th February 2003
Page 4 of 8

		accommodated.
		Relabel Harness S4 Type 1a not Type 1 because of its small variation compared to other Type 1s, i.e its link to S2.
		Add note to HSDCU J26 saying that this is the connector to which the 6 spare SSW bolometer channels would go if they were wired through. They are actually terminated at HSDCU end of S2 with 15K Ω resistors.
4.5	26/6/02	Shutter removed and thus launch latch SVM panel connectors simplified.
		37 and 78 way connector positions swapped on bias on HSDCU
4.6	9/7/02	Drawing re-arrangement of 28V Power wiring and HSFCU to HSDCU secondary feed cables to better represent recent update of DRCU ICDs. Not a hardware change.
		Sex of JTAG connectors on HSFCU changed...not an external SPIRE I/F.
		Small changes to order of modules in HSFCU
		All connectors on HSFCU mating to cryoharness rotated 180° relative to view of unit face as drawn....SPR-MX-5200 000 C
4.7	22/7/22	Corrected some S-harness tails on to HSFCU placed incorrectly in 4.6 changes
4.8	30/9/02	Change HSFCU J9/10/31/32 to be 25 pin not 15. HSFCU Internal harness.
4.9	11/10/02	Make RF Filter in FPU individual rather than pairs. Thanks Dominique.
5.0	19/11/02	Tidy up DCU, replacing J4 connector outline that disappeared in v4.9, and adding bolometer signal channel module numbers.
		Change label to Herschel Optical Bench so not confused with Spire item.
5.1	4/12/02	Alter BDA connector numbers and define Bulkhead feedthrough numbers.
		Added J numbers to SCAL and insides of RF Filters to aid definition of F harnesses.
5.2		Show 21 way connector on HSPTC, and then again, damn, change to 25 way
		Change SLW BDA Nanonics back to J6



SPIRE

INSTRUMENT BLOCK DIAGRAM

Doc #: SPIRE-RAL-DWG-000646
Issue: 5.2
Date: 14th February 2003
Page 5 of 8

ACRONYM LIST

Term	Meaning
ADC	Analogue to Digital Converter
AIV	Assembly, Integration and Verification
AME	Absolute Measurement Error
AOCS	Attitude and Orbit Control System
APART	Arizona's Program for the Analysis of Radiation Transfer
APE	Absolute Pointing Error
ASAP	Advanced Systems Analysis Program
AVM	Avionics Model
BDA	Bolometer Detector Array
BFL	Back Focal Length
BRO	Breault Research Organization
BSM	Beam Steering Mirror
CDMS	Command and Data Management System
CDMU	Command and Data Management Unit
CDR	Critical Design Review
CMOS	Complimentary Metal Oxide Silicon
CPU	Central Processing Unit
CVV	Cryostat Vacuum Vessel
DAC	Digital to Analogue Converter
DAQ	Data Acquisition
DCU	Detector Control Unit = HSDCU
DPU	Digital Processing Unit = HSDPU
DSP	Digital Signal Processor
DQE	Detective Quantum Efficiency
EDAC	Error Detection and Correction
EGSE	Electrical Ground Support Equipment
EMC	Electro-magnetic Compatibility
EMI	Electro-magnetic Interference
ESA	European Space Agency
FCU	FCU Control Unit = HSFCU
FIR	Far Infrared
FIRST	Far Infra-Red and Submillimetre Telescope
FOV	Field of View
F-P	Fabry-Perot
FPGA	Field Programmable Gate Array
FPU	Focal Plane Unit
FTS	Fourier Transform Spectrometer
FWHM	Full Width Half maximum
GSFC	Goddard Space Flight Center
HK	House Keeping
HOB	Herschel Optical Bench
HPDU	Herschel Power Distribution Unit
HSDCU	Herschel-SPIRE Detector Control Unit
HSDPU	Herschel-SPIRE Digital Processing Unit
HSFCU	Herschel-SPIRE FPU Control Unit
HSO	Herschel Space Observatory
IF	Interface
IID-A	Instrument Interface Document - Part A



SPIRE

INSTRUMENT BLOCK DIAGRAM

Doc #: SPIRE-RAL-DWG-000646

Issue: 5.2

Date: 14th February 2003

Page 6 of 8

Term	Meaning
IID-B	Instrument Interface Document - Part B
IMF	Initial Mass Function
IR	Infrared
IRD	Instrument Requirements Document
IRTS	Infrared Telescope in Space
ISM	Interstellar Medium
JFET	Junction Field Effect Transistor
ISO	Infrared Space Observatory
LCL	Latching Current Limiter
LIA	Lock-In Amplifier
LVDT	Linear Variable Differential Transformer
MAC	Multi Axis Controller
LWS	Long Wave Spectrometer (an instrument used on ISO)
MCU	Mechanism Control Unit = HSMCU
M-P	Martin-Puplett
NEP	Noise Equivalent Power
NTD	Neutron Transmutation Doped
OBS	On-Board Software
OMD	Observing Modes Document
OPD	Optical Path Difference
PACS	Photodetector Array Camera and Spectrometer
PCAL	Photometer Calibration source
PID	Proportional, Integral and Differential (used in the context of feedback control loop architecture)
PLW	Photometer, Long Wavelength
PMW	Photometer, Medium Wavelength
POF	Photometer Observatory Function
PROM	Programmable Read Only Memory
PSW	Photometer, Short Wavelength
PUS	Packet Utilisation Standard
RMS	Root Mean Squared
SCAL	Spectrometer Calibration Source
SCUBA	Submillimetre Common User Bolometer Array
SED	Spectral Energy Distribution
SMEC	Spectrometer Mechanics
SMPS	Switch Mode Power Supply
SOF	Spectrometer Observatory Function
SPIRE	Spectral and Photometric Imaging Receiver
SRAM	Static Random Access Memory
SSSD	SubSystem Specification Document
STP	Standard Temperature and Pressure
SVM	Service Module
TBC	To Be Confirmed
TBD	To Be Determined
TC	Telecommand
URD	User Requirements Document
UV	Ultra Violet
WE	Warm Electronics
ZPD	Zero Path Difference

HERSCHEL-SPIRE(HS)

HERSCHEL

HERSCHEL-SPIRE(HS)

HERSCHEL

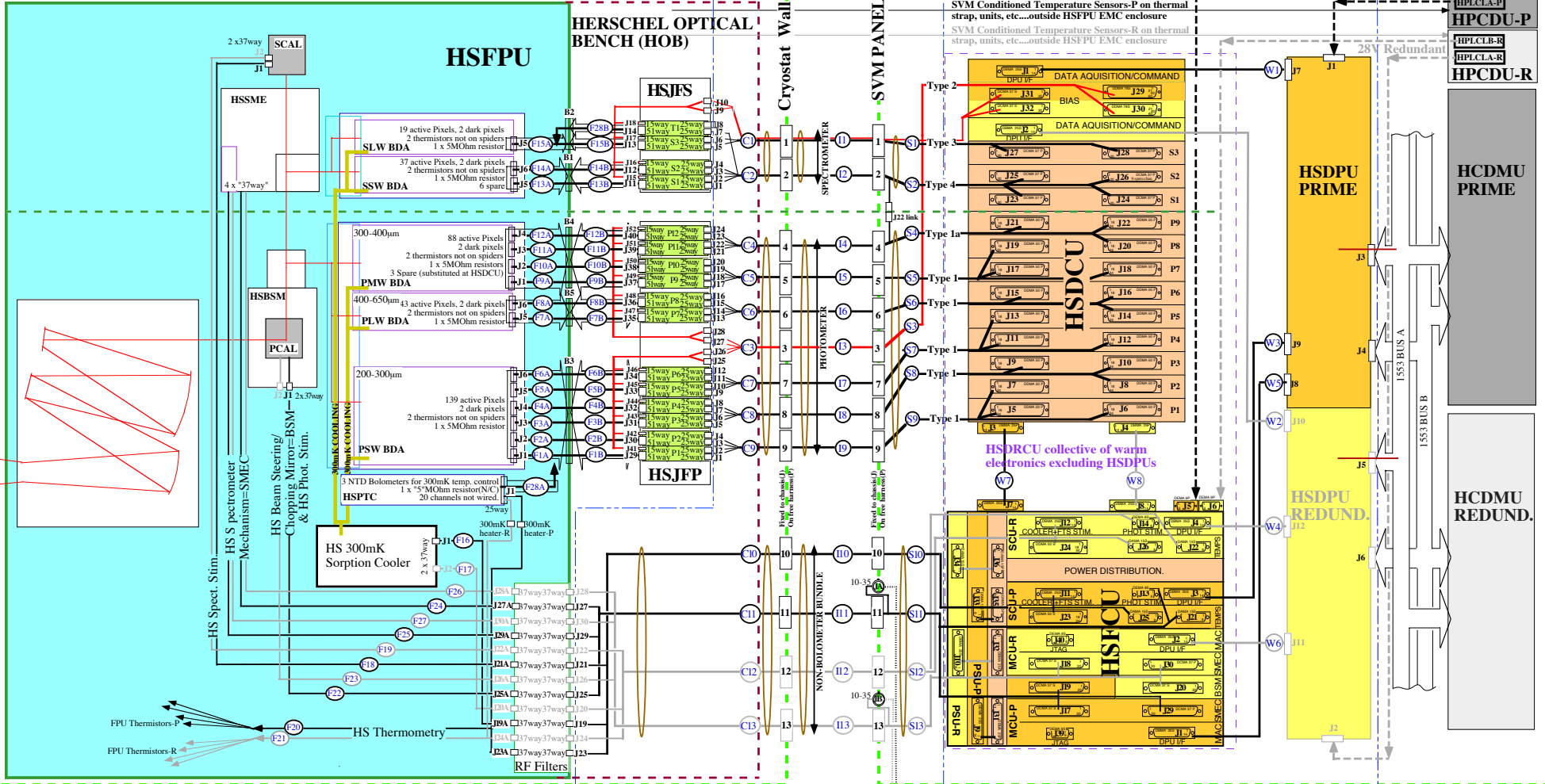

KEY

- Master clock
- Prime harness
- Herschel to Herschel/ Spire I/F lines, drawn simplified....I/Fs are all at HS connector planes
- Flight Harness Identity
- Redund. harness

CAUTION This instrument block diagram shows how SPIRE units relate functionally, it is not a harness specification. The connectors happen to be labelled with the names of the fixed items on the units, not the mating harness parts.

EGSE!