

SPIRE

SUBJECT: SPIRE IID B Chapter 5

PREPARED BY: J. Delderfield

DOCUMENT No: SPIRE-RAL-PRJ-000635

ISSUE: 2.3 **Date:** 29th June 2001

APPROVED BY:

Date:

Local Project Manager:

Project Manager: Ken King

Instrument Scientist: Bruce Swinyard

Systems Engineer: John Delderfield

Local PI: Matt Griffin

REFERENCE: SCI-PT-IIDB/SPIRE-02124

Chapter 5 Contents.

5	INTERFACE WITH SATELLITE	5-8
5.1	IDENTIFICATION AND LABELLING	5-8
5.2	INTERFACE LOCATIONS	5-8
5.2.1	MECHANICAL COORDINATE SYSTEM	5-10
5.3	LOCATION AND ALIGNMENT	5-10
5.3.1	Instrument Location	5-11
5.3.2	Instrument Alignment on the HOB	5-11
5.4	EXTERNAL CONFIGURATION DRAWINGS	5-12
5.4.1	FSFPU	5-12
5.4.2	HSJFS	5-15
5.4.3	HSJFP	5-15
5.4.4	SVM Mounted Units	5-15
5.5	SIZES AND MASS PROPERTIES	5-16
5.5.1	Mass on HERSCHEL Optical bench	5-16
5.5.2	Mass on Service Module	5-17
5.5.3	Moments of Inertia and C. of Gs.	5-17
5.6	MECHANICAL INTERFACES	5-18
5.6.1	Inside cryostat	5-18
5.6.2	Outside Cryostat	5-18
5.6.3	On SVM	5-18
5.6.4	On Planck Payload Module	5-18
5.6.5	Cooler valves and piping	5-18
5.7	THERMAL INTERFACES	5-19
5.7.1	Inside cryostat	5-19
5.7.2	Outside Cryostat	5-20
5.7.3	On SVM	5-21
5.7.4	On Planck Payload Module	5-21
5.7.5	Temperature channels	5-22
5.8	OPTICAL INTERFACES	5-24
5.8.1	Straylight	5-25
5.9	POWER	5-26
5.9.1	Inside cryostat	5-26
5.9.2	Outside Cryostat	5-26
5.9.3	On SVM	5-27
5.9.4	On Planck Payload Module	5-27
5.9.5	Power versus Instrument Operating Modes	5-27
5.10	POWER BUS INTERFACES	5-28
5.10.1	28 Volt main-bus	5-28
5.10.2	Keep Alive Line (KAL)	5-29
5.11	ELECTRICAL SIGNAL INTERFACES	5-30
5.11.1	1553 Data Buses	5-30
5.11.2	Master Clock	5-30
5.11.3	Launch confirmation	5-30
5.12	CONNECTORS, HARNESS, GROUNDING, BONDING	5-31
5.12.1	Harness and Connectors	5-31
5.12.2	Grounding	5-32
5.12.3	Bonding	5-33
5.13	DATA HANDLING	5-34
5.13.1	Telemetry	5-34

5.13.2	S/C housekeeping.....	5-34
5.13.3	Timing and synchronisation signals	5-34
5.13.4	Telecommand	5-36
5.14	ATTITUDE AND ORBIT CONTROL/POINTING	5-37
5.14.1	Attitude and orbit control	5-37
5.14.2	Pointing.....	5-37
5.14.3	On-Target Flag (OTF).....	5-37
5.15	ON-BOARD HARDWARE/SOFTWARE AND AUTONOMY FUNCTIONS	5-38
5.15.1	On-board hardware.....	5-38
5.15.2	On-board software	5-38
5.15.3	Autonomy functions	5-38
5.15.4	Instrument Autonomy Housekeeping Packet Definition	5-38
5.15.5	Instrument Event Packet Definition	5-38
5.16	EMC.....	5-39
5.16.1	Conducted Emission/Susceptibility	5-39
5.16.2	Radiated Emission/Susceptibility	5-39
5.16.3	Frequency Plan.....	5-39
5.17	Transport and Handling Provisions.....	5-40
5.17.1	Focal Plane Unit.....	5-40
5.17.2	JFET/Filter Boxes	5-40
5.17.3	Electronics Units	5-41
5.18	DELIVERABLE ITEMS	5-42
5.18.1	Instrument Models.	5-42
5.18.2	Electrical Ground Support Equipment (EGSE)	5-42
5.18.3	Mechanical Ground Support Equipment (MGSE)	5-42
5.18.4	Optical Ground Support Equipment (OGSE)	5-43
5.18.5	System Test Software.....	5-43
5.18.6	Hardware for the Observatory Ground Segment	5-43
5.18.7	Software for the Observatory Ground Segment.....	5-43
5.18.8	Instrument Software Simulator.....	5-43
5.18.9	Test Reference Data.....	5-43
5.18.10	Instrument Characterisation Data	5-43
5.18.11	Technical Documentation	5-43

CHANGE RECORD from IIDR

ISSUE	DATE	SECTION	CHANGE(S) MADE
2.0	18/4/01	All	Baseline reviewed at IIDR
2.1	6/6/01	5.19.1	Section had included BSM markups in 2.0 despite being labelled "Not updated". Tidied up.
		Figure 5.2.1	Insert most up-to-date version
		All	Highlighted in red text needing ESA action, presumably via its agent Alcatel.
		5.3.2.1	Temporarily scored through optical alignment numbers because what is written is incorrect.
		5.7.3	Add E-mailed max rate of change of SVM unit temperatures.
		5.9	Note that ray diagrams are due for update
		5.13.1	Put in latest Harness Layout drawing.
		5.13.2	Add comment about FCU driven subsystems in FPU
2.2	19/6/01		Inserted Acronym list
		Fig.5.2.1	Insert most up-to-date version
		5.13.1	Put in latest Harness Layout drawing without duplicate J26 at FCU!.
		5.10.3+ 5.11	Add detail + LCL supply split.
		5.12.2	Remove Synchronisation and insert Master Clock
		Various	Residual First and F replaced with HERSCHEL and H.
		Various	Typos and incorrect references.
		5.6.1.2	Add words about Spire supporting the thermal straps.
2.3(jd)	29.6/01	Header	Make doc. number clearly not the issued ESA IID-B
	changes	5.10.1.3	Add Platform monitoring Spire supplies as per fax.
	after	5.6.1.1	Make it clear that microvibration level is under review.
	meeting	5.7.5.2	Update names and positions. Add proviso about further optimisations.
		5.9.3	New headings more applicable to IID-B
		5.5	New headings more applicable to IID-B. Add reference to value of Spire's flight allocation.
		5.10.2	KAL section shortened but left in document.
		5.13.1.2	Change "short duration" to "up to 5 minutes".
		5.13.1.3	Clarify storage time to polling period ratio.
		5.13.1.1.	Add reference to Spire's data rate flight allocation. Fix error in Hsk. rate. Now 2Kbps as in budget 3.2 spreadsheet.
		5.4	Include preliminary version 8 ICDs with markings.
		5.17.3.1	Change cleanroom class for SVM units to 100,000
		5.16.3	Remove requirement for synchronisation...error to leave in
		5.14.1	May clear what is information and what is I/F Requirement.
		5.4.4	Insert SVM mounted units approx sizes and configuration.
		5.13.2	Make data route for packets clear
		5.13.3	Insert rationale.
		5.1.5	Insert temperature measuring details.
		Fig.5.2.1	Insert most up-to-date version
		5.3.2	Replace old section

		5.13.12	Add provision of SVM unit bonding bosses.
		5.10.1.4	Reword LCL Fault section.
		5.9.1	Note added about lack of splitdown etc. in budgets.
		5.7.1.2	Change from temperature based spec. to a conductance one.

ACRONYM LIST

Term	Meaning
ADC	Analogue to Digital Converter
AIV	Assembly, Integration and Verification
AME	Absolute Measurement Error
AOCS	Attitude and Orbit Control System
APART	Arizona's Program for the Analysis of Radiation Transfer
APE	Absolute Pointing Error
ASAP	Advanced Systems Analysis Program
AVM	Avionics Model
BDA	Bolometer Detector Array
BFL	Back Focal Length
BRO	Breault Research Organization
BSM	Beam Steering Mirror
CDMS	Command and Data Management System
CDMU	Command and Data Management Unit
CDR	Critical Design Review
CMOS	Complimentary Metal Oxide Silicon
CPU	Central Processing Unit
CVV	Cryostat Vacuum Vessel
DAC	Digital to Analogue Converter
DAQ	Data Acquisition
DCU	Detector Control Unit = HSDCU
DPU	Digital Processing Unit = HSDPU
DSP	Digital Signal Processor
DQE	Detective Quantum Efficiency
EDAC	Error Detection and Correction
EGSE	Electrical Ground Support Equipment
EMC	Electro-magnetic Compatibility
EMI	Electro-magnetic Interference
ESA	European Space Agency
FCU	FCU Control Unit = HSFCU
FIR	Far Infrared
FIRST	Far Infra-Red and Submillimetre Telescope
FOV	Field of View
F-P	Fabry-Perot
FPGA	Field Programmable Gate Array
FPU	Focal Plane Unit
FTS	Fourier Transform Spectrometer
FWHM	Full Width Half maximum
GSFC	Goddard Space Flight Center
HK	House Keeping
HOB	Herschel Optical Bench
HPDU	Herschel Power Distribution Unit
HSDCU	Herschel-SPIRE Detector Control Unit
HSDPU	Herschel-SPIRE Digital Processing Unit
HSFCU	Herschel-SPIRE FPU Control Unit
HSJFS	Herschel-SPIRE JFETs(Spectrometer)
HSJFP	Herschel-SPIRE JFETs(Photometer)
HSO	Herschel Space Observatory
IF or I/F	Interface
IID-A	Instrument Interface Document - Part A

Term	Meaning
IID-B	Instrument Interface Document - Part B
IMF	Initial Mass Function
IR	Infrared
IRD	Instrument Requirements Document
IRTS	Infrared Telescope in Space
ISM	Interstellar Medium
JFET	Junction Field Effect Transistor
ISO	Infrared Space Observatory
LCL	Latching Current Limiter
LIA	Lock-In Amplifier
LVDT	Linear Variable Differential Transformer
MAC	Multi Axis Controller
LWS	Long Wave Spectrometer (an instrument used on ISO)
MCU	Mechanism Control Unit = HSMCU (hardware within HSFCU)
M-P	Martin-Puplett
NA or N/A	Not Applicable
NEP	Noise Equivalent Power
NTD	Neutron Transmutation Doped
OBS	On-Board Software
OMD	Observing Modes Document
OPD	Optical Path Difference
PACS	Photodetector Array Camera and Spectrometer
PCAL	Photometer Calibration source
PID	Proportional, Integral and Differential (used in the context of feedback control loop architecture)
PLW	Photometer, Long Wavelength
PMW	Photometer, Medium Wavelength
POF	Photometer Observatory Function
PROM	Programmable Read Only Memory
PSW	Photometer, Short Wavelength
PUS	Packet Utilisation Standard
RMS	Root Mean Squared
SCAL	Spectrometer Calibration Source
SCU	Subsystems' Control Unit (hardware within HSFCU)
SCUBA	Submillimetre Common User Bolometer Array
SED	Spectral Energy Distribution
SMEC	Spectrometer Mechanics
SMPS	Switch Mode Power Supply
SOF	Spectrometer Observatory Function
SPIRE	Spectral and Photometric Imaging Receiver
SRAM	Static Random Access Memory
SSSD	SubSystem Specification Document
STP	Standard Temperature and Pressure
SVM	Service Module
TBC	To Be Confirmed
TBD	To Be Determined
TC	Telecommand
URD	User Requirements Document
UV	Ultra Violet
WE	Warm Electronics
ZPD	Zero Path Difference

APPLICABLE DOCUMENTS

Section to be inserted as IID-B is consolidated

REFERENCE DOCUMENTS

Section to be inserted as IID-B is consolidated

5 INTERFACE WITH SATELLITE

Spacecraft resource allocations are based on present knowledge.

5.1 IDENTIFICATION AND LABELLING

Each individual instrument unit is allocated two unique identification codes:

- a *project code* which is the normal reference used for routine identification in correspondence and technical descriptive material.
- a *spacecraft code* finalised by the spacecraft contractor in accordance with the computerised configuration control system to be implemented, and used in particular for connector and harness identification purposes. All of these have now been given a working designation anyway as work has progressed. The *project code* shall form part of the spacecraft code. (See IID-A section 5.1)

The project codes allocated to this instrument are:

Project code	Instrument unit	Location	Temperature
HSDPU	HS Digital Processing Unit	On SVM	Warm
HSFCU	HS FPU Control Unit	On SVM	Warm
HSDCU	HS Detector Control Unit	On SVM	Warm
HSJFS	HS JFETs(Spectrometer)	See section 5.3	Cryogenic
HSJFP	HS JFETs(Photometer)	See section 5.3	Cryogenic
HSFPU	HS Focal Plane Unit	See section 5.3	Cryogenic

in which HS stands for HERSCHEL **Spire**, and may be omitted if the context is unambiguous.

The HSFCU is a physical unit containing two functions, the HSSCU and the HSMCU meaning the HS Sub-System Control Unit and the HS Mechanisms' Control Unit respectively.

[Documentation may refer to a DRCU or Detector Readout and Control Unit. This is no longer a single unit and the term refers collectively to the HSDCU plus the HSFCU.]

There are three groups of harnesses at instrument interface level, HSWxx, HSIxx and HSCxx where xx represents a number. The HSWxx are Warm harnesses between Warm HS units on the SVM. The HSIxx are Intermediate harness external to the cryostat between the 100way vacuum connectors and the HS Warm Units. The HSCxx are cryogenic harness internal to the cryostat between the 100way vacuum connectors and the HS Cryogenic units.

5.2 INTERFACE LOCATIONS

All of the above is best visualised as a block diagram, see figure 5.2.1. The HERSCHEL to HERSCHEL-**Spire** electrical interfaces are in several "planes" shown by dashed blue lines, the categories between each line being labelled along the top.

Note that, to be precise, these electrical interfaces are at the connector planes.

End 29th June 2001

HERSCHEL-SPIRE(HS)

HERSCHEL

HERSCHEL-SPIRE(HS)

HERSCHEL

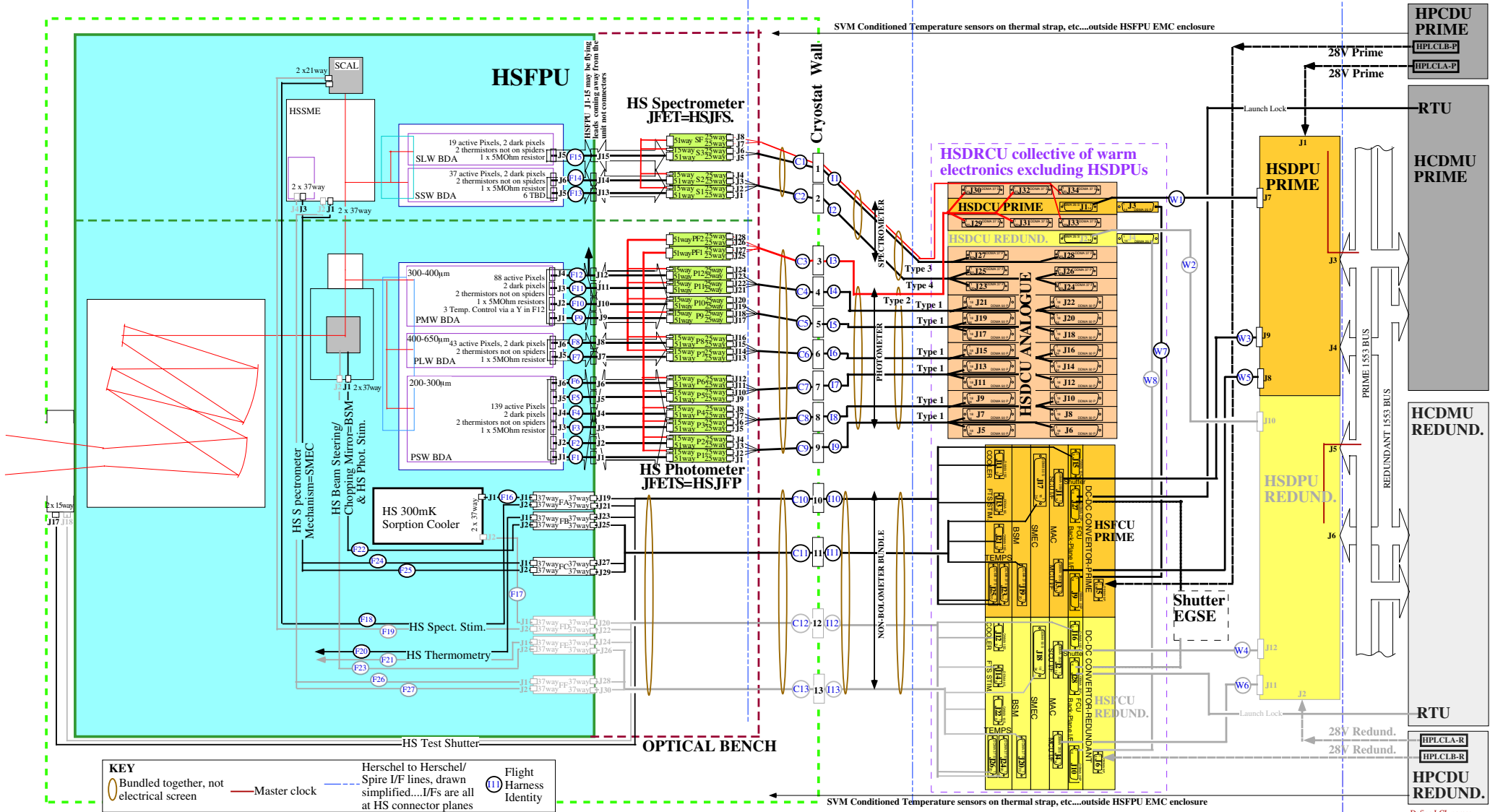

Use JPL BDA connector numbers and red backharness bundling-ref23835

Spire Block Diagram Figure 5.2.1

Define LCL names

5.2.1 MECHANICAL COORDINATE SYSTEM

The unit specific x,y,z origin definitions are shown in the External Configuration Drawings. (see section 5.4)

5.3 LOCATION AND ALIGNMENT

Figures 5.3-1 and 5.3-2 show the concept of the location of the three HERSCHEL Focal Plane Units (FPUs) for HIFI, PACS and **Spire** on the Optical Bench (OB) inside the cryostat. The **Spire** FPU has two closeby JFET racks. **This accommodation may be subject to detailed evolution.**

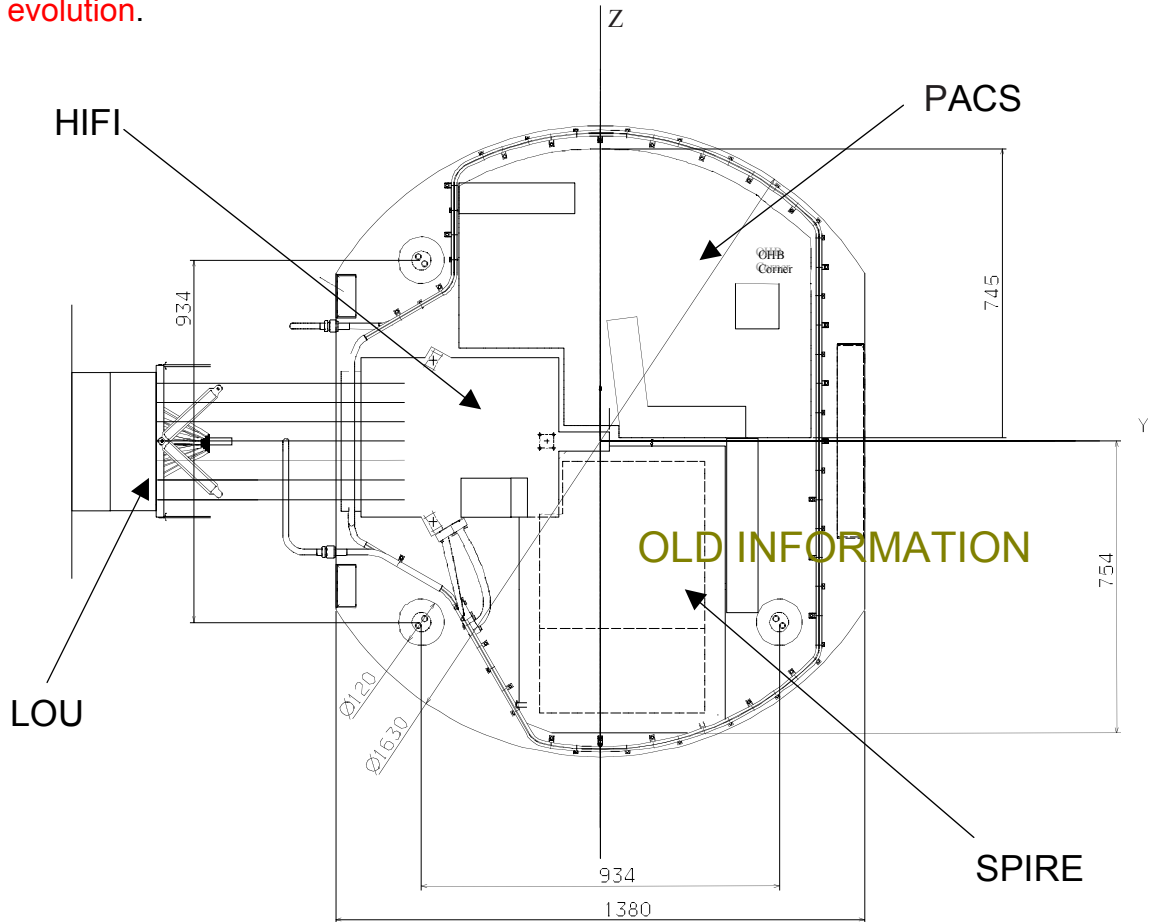

Figure 5.3-1: The HERSCHEL Focal Plane, top view towards -X

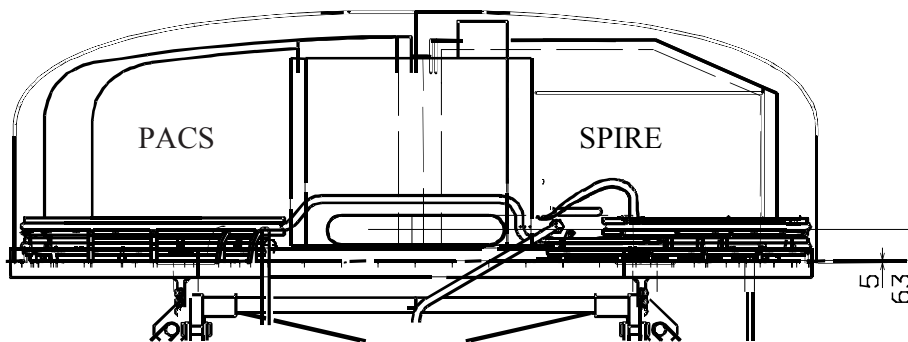

Figure 5.3-2: The HERSCHEL Focal Plane, side view towards +Y

5.3.1 Instrument Location

The locations of the **Spire** units are as listed in section 5.1. **Spire** has no units supported on the outside of the HERSCHEL cryostat or on the Planck Module. There are no critical alignment requirements on the **Spire** JFET boxes.

5.3.1.1 Location of units on the SVM

There are no specific requirements for the location of **Spire** units on the SVM, except that the DRCU needs optimised harness routing towards the **Spire** quadrant of cryostat 100way connectors. **ESA shall advise the Spire Instrument consortium of harness and unit position definitions and 100way type at the earliest date, for comment and for them be recorded herein.**

5.3.2 Instrument Alignment on the HOB

Spire has no critical alignment and/or alignment stability requirements except for those of the HSFPU.

The HSFPU has an externally viewable alignment cube as shown on its ICD. Both the cube's angular alignment and the position of the HSFPU box' feet w.r.t. its internal optics will have been established at instrument level to a defined tolerance before delivery to ESA.

The mechanical process of mounting **Spire** on the HOB so that it is aligned to the HERSCHEL telescope (when both are at operating temperature) is worked through in ADaaa. This defines an error budget for how well the alignment has to be achieved, as well as how stable it then has to remain.

[Insert summary table of ADaaa's conclusions here when available]

*Note **Spire's** alignment philosophy. Because it is a quantitative radiometer, **Spire** needs to have a fixed and maximised optical throughput. As it views "into" a warm telescope, vignetting and stray radiance need to be minimised. The HERSCHEL telescope secondary mirror M2 defines the systems' entrance pupil and is an optical conjugate of a physical mask within **Spire's** optics. The optical throughput of the SPIRE instrument is therefore dependent on maintaining the co-alignment between this physical mask and the image of M2. The alignment procedure and tolerances defined in Adaaaa are based on achieving values of displacement and rotational error between the image of M2 and the mask.*

Simultaneously with this alignment, designs must be such that the images of the effective inputs of the bolometer feedhorns lie sufficiently close to the focal surface of the HERSCHEL telescope that the required definition of instrument pixel FOV is realised.

5.4 EXTERNAL CONFIGURATION DRAWINGS

These are included for information only. They are all controlled **Spire** drawings at their latest issue.

5.4.1 FSFPU

Figure 5.4-1 shows drawings for the HSFPU and HSJFS/JFP inside the cryostat and their relationship to the HERSCHEL focal plane, to the cryostat radiation shield and to the diameter of the HOB. The location of both of the JFET racks will need to be optimised to provide short cable lengths to the detectors in the FPU (the reason for their existence) and good routing from their opposite faces for the cryoharness feeds.

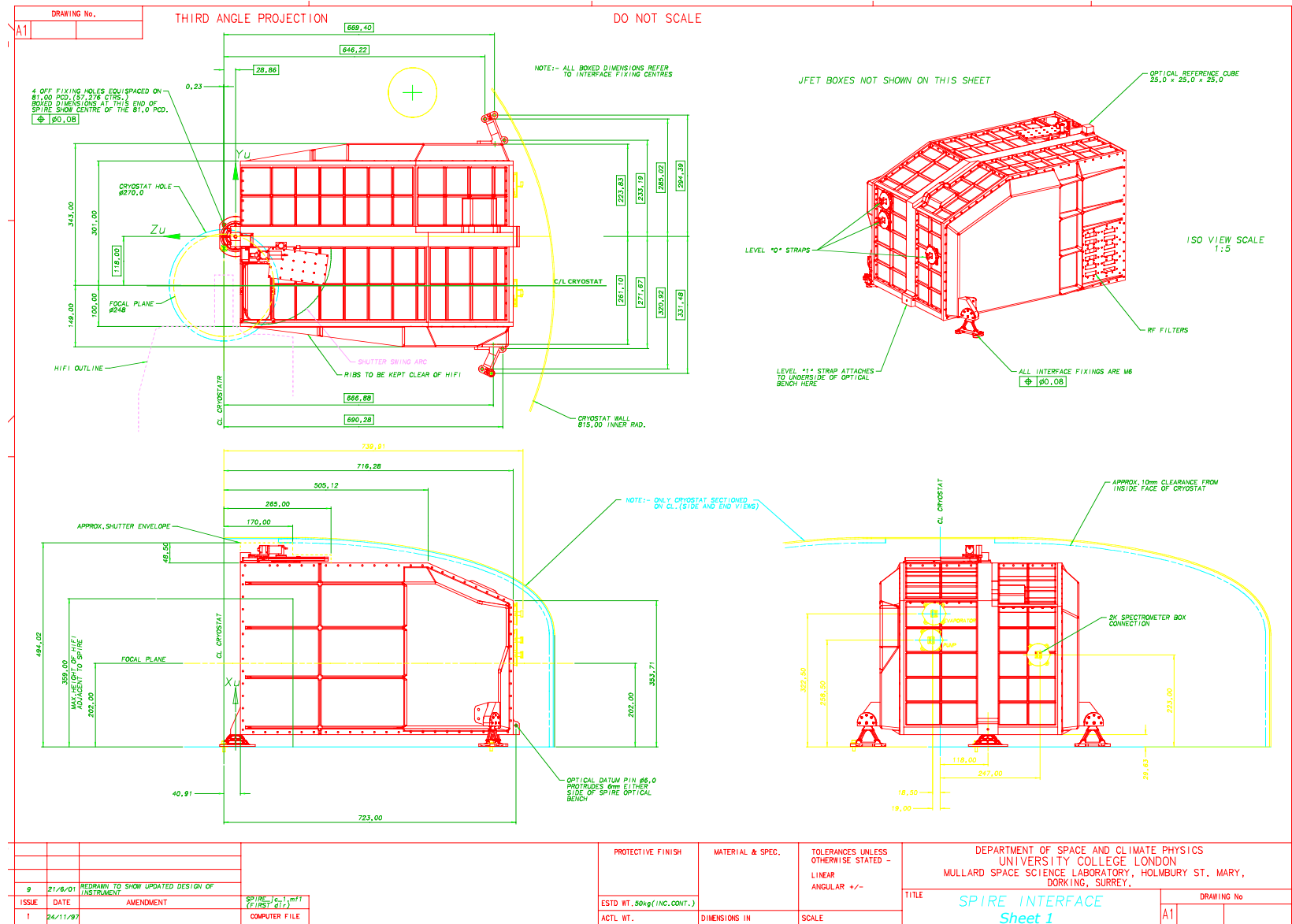

Figure 5.4-1a: **Spire** Focal Plane Unit....sheet 1

Spire cold harness routing added but NOT agreed.

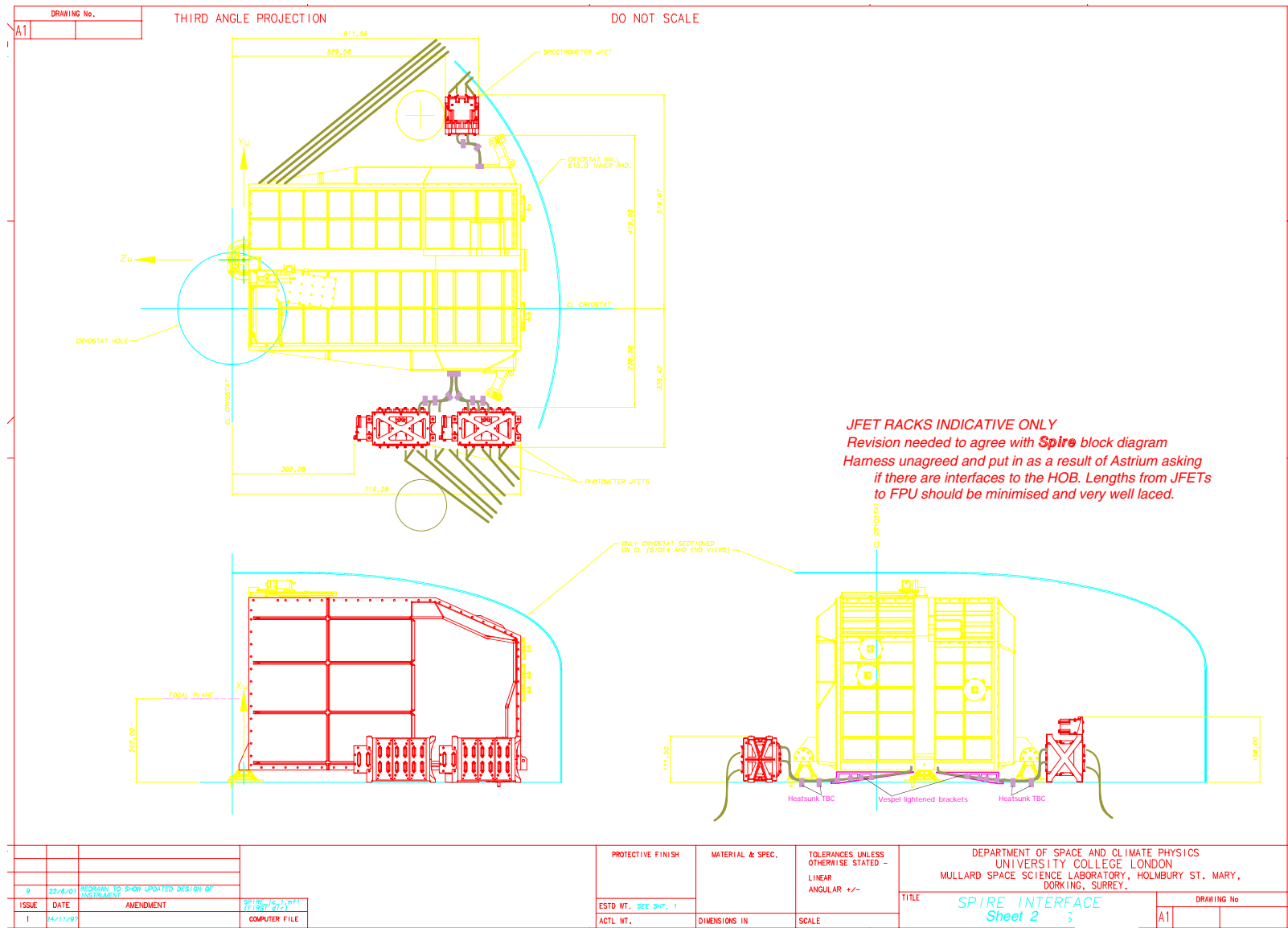

Figure 5.4-1b: **Spire** Focal Plane Unit...sheet 2. The position and size of the JFET boxes is indicative only.

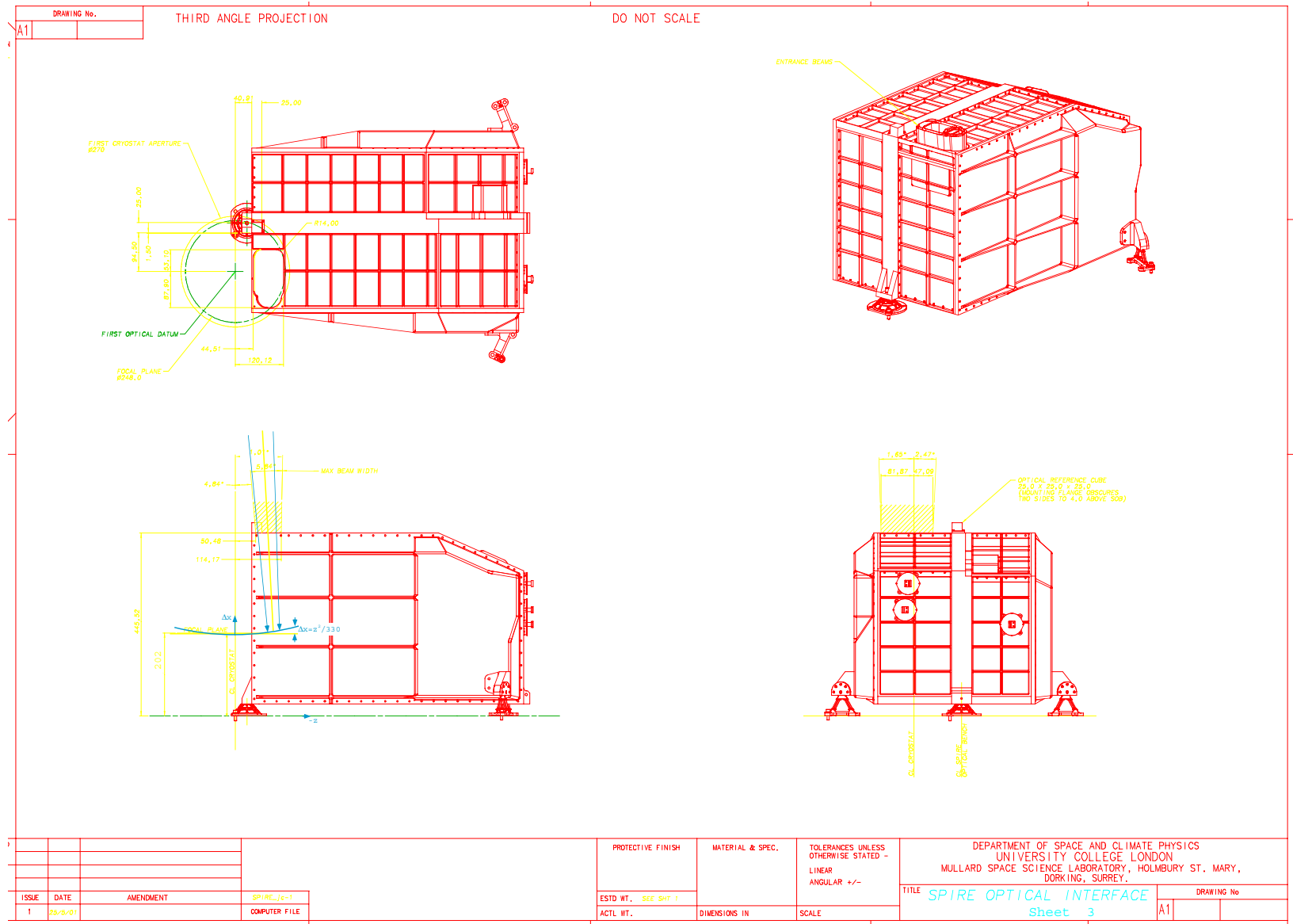

Figure 5.4-1c: **Spire** Focal Plane Unit....sheet 3

5.4.2 HSJFS

Figure 5.4-3 shows the external configuration drawing for the **Spire** Spectrometer JFET rack (TBW).

5.4.3 HSJFP

Figure 5.4-4 shows the external configuration drawing for the **Spire** Photometer JFET rack (TBW).

5.4.4 SVM Mounted Units.

The following layout is TBC and preliminary:

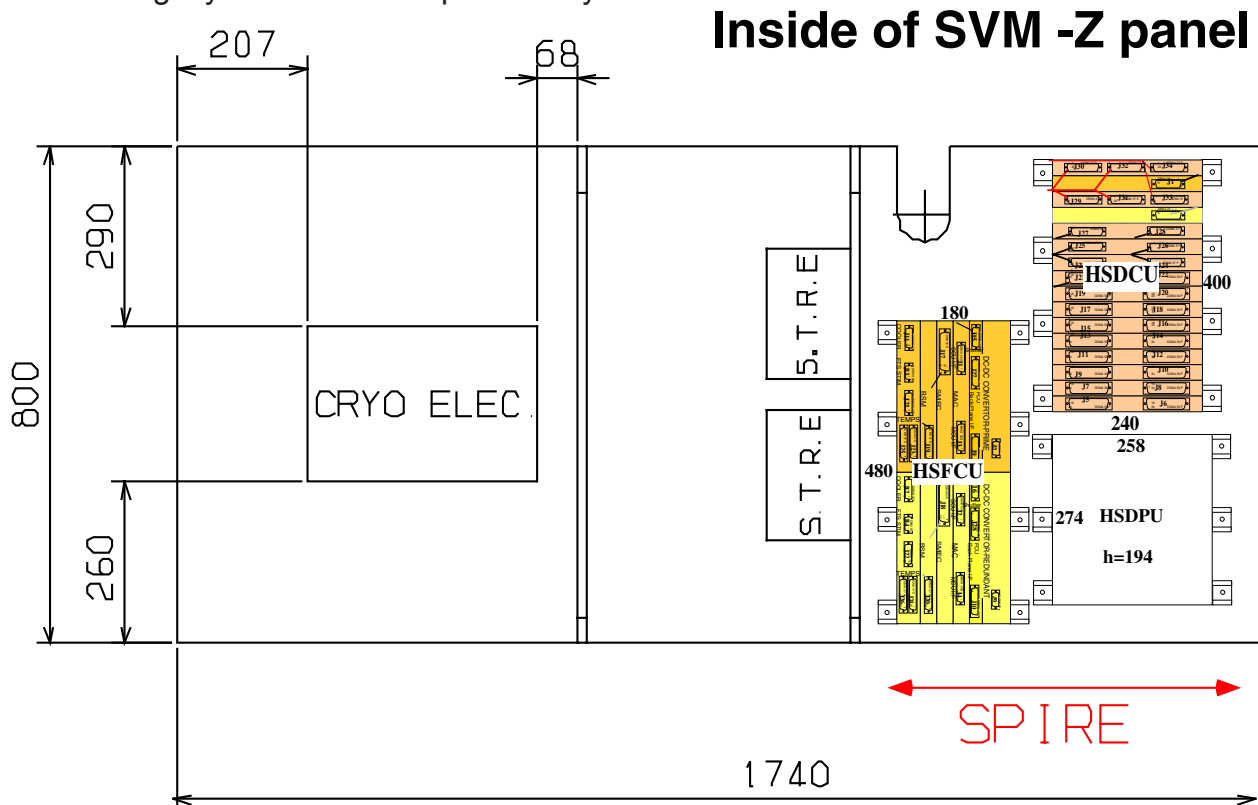

Figure 5.4-5 **Spire** SVM mounted units and the **Spire** Warm harness' routing.

5.4.4.1 HSDPU

Figure 5.4-6 shows the external configuration drawing for the **Spire** Digital Processing Unit (TBW).

5.4.4.2 HSDCU

Figure 5.4-7 shows the external configuration drawing for the **Spire** Detector Control Unit (TBW).

5.4.4.3 HSFCU

Figure 5.4-8 shows the external configuration drawing for the **Spire** FPU Control Unit (TBW).

5.5 SIZES AND MASS PROPERTIES

Sizes are given in section 5.4. There follows a mass summary in grams extracted from the definitive **Spire** Budgets' Document, Adxxxx.

The **Spire** internal budgets [with all contingencies unrealistically going to their maxima] as detailed below sum to 99.56Kg. **Spire's** mass allocation for flight is 90Kg.

5.5.1 Mass on HERSCHEL Optical bench

Item	Estimate	Spire Internal Budget	Contingency %	Budget + Cont.
Photometer				
Mirrors	1019	1020	10	1122
Mirrors	348	350	10	385
Filters	8	10	10	11
Filters	539	540	20	648
Detectors	1680	1500	20	1800
Thermal Straps	282	285	20	342
Cooler	1400	1400	10	1540
Cooler Straps	235	235	20	282
Baffles	2420	2420	20	2904
Calibration Source	30	30	20	36
Detector Harness	1275	1300	0	1300
BSM (& support)	1100	1100	20	1320
Shutter	200	200	20	240
Non- bolometer RF Filters & Box	1720	1720	10	1892
<i>Clamshell Cover</i>	7640	7650	15	8797.5
Detector Box	1840	1850	15	2127.5
Mounts,clamps	1310	1310	15	1506.5
TOTAL	23046	22920		26082
Spectrometer				
Mirrors	1312	1320	10	1452
Filters	65	65	10	71.5
Filters	2	2	10	2.2
Detectors	897	1000	20	1200
Harness	200	200	0	200
Mechanism	1100	1100	20	1320
SMECP	200	200	20	240
<i>Clamshell Cover</i>	6880	6880	15	7912
Detector box	1350	1350	15	1552.5
Mounts,clamps	860	860	15	989
Calibration Source	200	200	20	240
TOTAL	13066	13177		15179
Optical Bench	8000	9000	15	10350
Mounting	540	540	15	621
Cooler I/F	100	100	20	120
Strap Baffles	500	500	20	600
TOTAL	9140	10140		11691
TOTAL FPU	45252	46237		52952

JFET Boxes				
JFET Modules	5490	5500	10	6050
JFET Rack Structure	1500	1500	20	1800
JFET - FPU Interface	300	300	20	360
Back Harness???				
TOTALJFETS	7290	7300		8210

5.5.2 Mass on Service Module

Item	Estimate	Spire Internal Budget	Contingency %	Budget + Cont.
Item	Estimate	Allocation	Contingency %	All.+Cont
HSDPU	6621	7000	20	8400
HSFCU+HSDCU	23000	23000	20	27600
HSW1-8	2000	2000	20	2400
TOTAL	31621	32000		38400

5.5.3 Moments of Inertia and C. of Gs.

The positions of C. of Gs. are shown on drawings in section 5.4.

The x,y,z principle moments about these are as follows: TBD.

5.6 MECHANICAL INTERFACES

5.6.1 Inside cryostat

The Focal Plane Unit, the HSFPU, has 3 supporting feet to the Optical Bench. The details of this mechanical interface will be such as to allow the unit alignment and alignment-stability requirements to be fulfilled.

The **Spire** JFET racks will also mechanically interface directly to the Optical Bench.

To fulfil **Spire**'s grounding requirements, the HSFPU and both JFET racks need to be electrically isolated from the Optical Bench at their mechanical mounting points. The same applies to the bolometer system harness screens.

5.6.1.1 Microvibration

Spire's mechanisms (SMEC and BSM), not just the bolometer system itself, are sensitive to μ -vibrations. The maximum permissible input acceleration input by HERSCHEL to the FPU HOB interface is $10\mu\text{g}$ peak, a level which is TBC and probably will be amended to a function that depends on frequency.

It is also expected **Spire** that will be subject to a restriction on the forces that it can output at this interface, TBC.

5.6.1.2 Thermal Straps

The mechanical I/F geometry, fixing torque, etc. for each of these straps is as baselined in the IIDA. See section 5.4 for positions on **Spire** and section 5.8 for more details. The thermal straps will be steadied by non-metallic **Spire** A-frames on the outside of the FPU, designed to minimise the forces the straps can apply to thermal leadthroughs, but not be Ohmic shorts.

5.6.2 Outside Cryostat

NA

5.6.3 On SVM

The three units mounted on the SVM will each have 6 or 8 attachment points for fixation to the equipment platform, as shown in their External Configuration Drawings. Interface flatnesses, fasteners and tightening torques are all defined on these drawings.

The **Spire** warm harness will attach to the SVM via TBD ESA provided holddown ties.

5.6.4 On Planck Payload Module

NA

5.6.5 Cooler valves and piping

NA

5.7 THERMAL INTERFACES

The cryogenic interfaces are the most important category of interfaces for **Spire**'s success, and the most complicated. They would provide the most gain to science performance from being somewhat improved.

5.7.1 Inside cryostat

The various instrument stages require straps to 3 different temperatures. The cryostat shall provide:

- Level 0: He tank for temperatures at the ~1.7 K
- Level 1: He vent-line at about ~4K
- Level 2: He vent-line at about ~10 K which may be achieved by conduction to the HOB.

An overview of this system is:

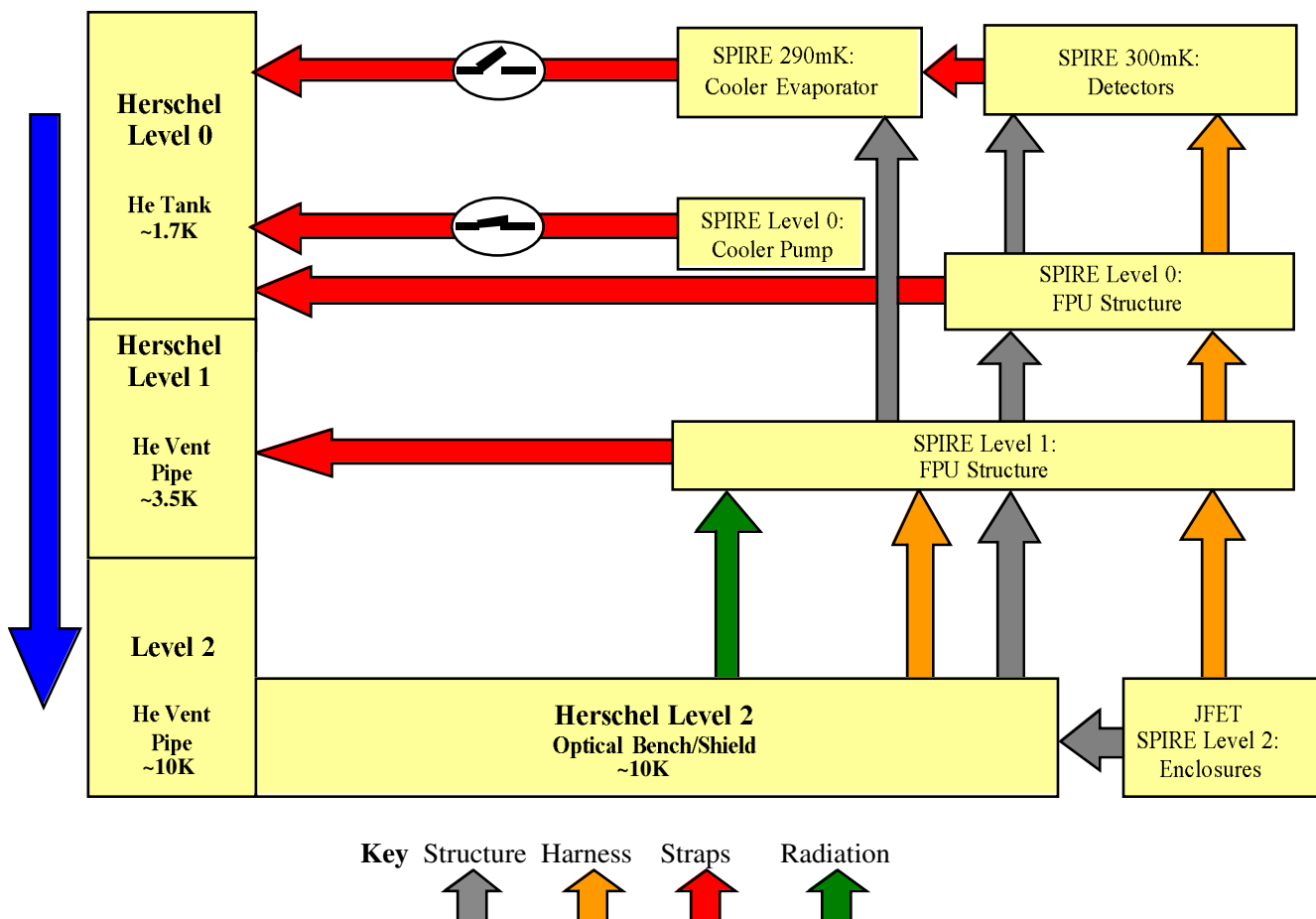

5.7.1.1 Thermal Straps for ³He Cooler

Operation of the **Spire** ³He cooler requires that it is recycled by heating the sorption pump to ~40-K whilst the evaporator is kept at 1.7-K, thus condensing the ³He into the evaporator. The temperature of the evaporator during condensation is critical to the overall efficiency of the cooler.

At the end of the condensation phase the heat switch on the sorption pump is turned ON and the switch on the evaporator is turned OFF. Then there is a substantial peak power

from the sorption pump to the cryostat as it re-cools via the strap. This peak power and associated energy will not have any significant impact on the cryostat LHe tank. However it will have a significant temporary impact on the thermal gradient along the strap.

There are two straps from the cooler to separate points on the LHe tank, one for the sorption pump and one for the evaporator. In this way, during normal operation, the temperature of the evaporator strap will remain at $T_{\text{bath}} + \Delta T$ (as small as possible), leading to a good condensation efficiency and less ^3He lost during the cooldown from 1.7 K to 0.3 K. The sorption pump will still operate properly even if the "hot" end of its strap rises momentarily to as much as 10 K.

The **Spire** FPU provides two Level 0 thermal strap interfaces to the ^3He cooler. It also provides a third, separate, Level 0 strap interface for its 1.8K optical box structures which are interconnected internally so as to have just one instrument external I/F.

For ESA cryostat strap mechanical and electrical I/F details see sections 5.7 and 5.14.2.

5.7.1.2 Requirements on Strap I/F temperatures

Spire interfaces require to be adequately cooled by HERSHEL Level 0 straps. The straps shall have at least the following conductances seen at the **Spire** I/F plane, and act towards a sink at 1.7Kelvin:

Strap	Conductance	Nominal Heatflow
Enclosure	0.05 Watts/Kelvin	1 to 3mW
Cooler Pump	0.05 Watts/Kelvin	0.25 to 1.8mW
Cooler Evaporator	0.1Watts/Kelvin	0.25 to 0.6mW

where the reason for including the heatflow is that it will change the temperature of the warm ends and hence the straps' conductivity.

The Level 1 HSFPU strap shall have a conductance of $>0.05\text{Watts/Kelvin}$. In this case the sink is to an HE boil-off pipe, so the cooling delivered to the **Spire** interface is not guaranteed by the strap conductance alone. At a worst case load of 18.25mWatts, which is a value **Spire** is presently trying not to need, this strap's equilibrium interface temperature shall remain $<5\text{Kelvin}$. With the specified conductance value, this corresponds to the nominal 3.5Kelvin level 1 boil-off pipe being raised to 4.63K

We ought to note that instrument performance would benefit if these were improved.

No HSJFS or HSJFP straps are listed because the present design uses direct mounting conduction to the HOB, so they are not fitted, TBC.

5.7.1.3 Worst case temperatures

The cryogenic units must withstand the full thermal environment given in the IIDA, including repeated max. 72hr. 80°C bakeouts and indefinite 60°C soak.

5.7.2 Outside Cryostat

NA

5.7.3 On SVM

The table below shows the required operating temperatures at the interface of the instrument unit with a mounting platform or parts thereof:

Project code	Operating		Start-up °C	Switch-off °C	Non-operating	
	Min. °C	Max. °C			Min. °C	Max. °C
HSDPU	- 15	+ 45	- 30	+ 50	- 35	+ 80
HSFCU	- 15	+ 45	- 30	+ 50	- 35	+ 80
HSDCU	- 15	+ 45	- 30	+ 50	- 35	+ 80

Note:

Acceptance temperature range is from 5⁰ below min. to 5⁰ above max. operating temp.

Qualification temperature range is from 10⁰ below min. to 10⁰ above max. operating temp.

During nominal operation in-flight, the SVM units will not move at more than 3K/hour.

Spire units will use the SVM as a thermal I/F, without formal isolation, to help stabilise the temperature of unpowered sections and absorb dissipated heat when powered by conduction. The units have an anodized aluminium general surface finish. If it is found that other arrangements are needed, such as low temperature limit thermostatted heaters, these shall be external and HERSCHEL furnished. If details are determined on timescales that can be accommodated, **Spire** will build in minimal necessary mounting arrangements for such systems, TBC.

5.7.4 On Planck Payload Module

NA

5.7.5 Temperature channels

5.7.5.1 Instrument Temperature Sensors

The table below shows the measurement of instrument cryogenic temperatures. These data are available in DPU packets (unless otherwise indicated) via whichever is powered of the prime and redundant sides of the **Spire** electronics.

Each side uses different, electrically isolated sensors and will therefore have subtly differing electrical to temperature calibrations. Note that the accuracy columns that follow refer to the performance of the complete system including cryoharness and electronics, not the sensors alone. "Resolutions" and "Accuracy" will need to be further defined as they are actually temperature dependant.

Regarding Cernox sensors, the logic is that type CX-1030 is used for the 300 mK stage, CX-1050 for accurate measurement at <10 Kelvin and CX-1070 for monitoring the temperature during cooldown.

Location IN HSFPU	Acronym	Sensor Type	Temp. Range	Resol.	Acc.
200-300 μ m PSW BDA	T_PSW_1	NTD Ge Thermistor*	0.2 K>5 K	TBD	TBD
200-300 μ m PSW BDA	T_PSW_2	NTD Ge Thermistor	0.2 K>5 K	TBD	TBD
300-400 μ m PMW BDA	T_PMW_1	NTD Ge Thermistor	0.2 K>5 K	TBD	TBD
300-400 μ m PMW BDA	T_PMW_2	NTD Ge Thermistor	0.2 K>5 K	TBD	TBD
400-650 μ m PLW BDA	T_PLW_1	NTD Ge Thermistor	0.2 K>5 K	TBD	TBD
400-650 μ m PLW BDA	T_PLW_2	NTD Ge Thermistor	0.2 K>5 K	TBD	TBD
SSW BDA	T_SSW_1	NTD Ge Thermistor	0.2 K>5 K	TBD	TBD
SSW BDA	T_SSW_2	NTD Ge Thermistor	0.2 K>5 K	TBD	TBD
SLW BDA	T_SLW_1	NTD Ge Thermistor	0.2 K>5 K	TBD	TBD
SLW BDA	T_SLW_2	NTD Ge Thermistor	0.2 K>5 K	TBD	TBD
300mK Plumbing Cntrl_1	TBD	NTD Ge Thermistor	0.2 K>5 K	0.05mK	0.5mK
300mK Plumbing Cntrl_2	TBD	NTD Ge Thermistor	0.2 K>5 K	0.05mK	0.5mK
300mK Plumbing Cntrl_3	TBD	NTD Ge Thermistor	0.2 K>5 K	0.05mK	0.5mK
JFET temps (15off)	TBD	"Heater"Thermistor?	10K>120K	0.5K	1K
Spect JFET chassis	TBD	CX-1070	3K>100K	0.5K	1K
Phot JFET chassis.	TBD	CX-1070	3K>100K	0.5K	1K
FSFPU optical bench.	TBD	CX-1070	3K>100K	25mK	50mK
Photometer 2K box	TBD	CX-1050	1K>10K	2mK	10mK
Spectrometer 2K box	TBD	CX-1050	1K>10K	2mK	10mK
M3,5,7Optical Sub-bench	TBD	CX-1050	3K>100K	25mK	50mK
FTS Flood Stim.	TBD	CX-1070	3K>80K	5mK	20mK
FTS Point Stim. TBC	TBD	CX-1070	3K>80K	5mK	20mK
Pump	TBD	CX-1050	1K>50K	10mK	20mK?
Evap.	TBD	CX-1030	0.2 K>5 K	1mK	1mK
Shunt.	TBD	CX-1030	0.2 K>5 K	1mK	1mK
Pump heat switch	TBD	CX-1050	1K>50K	10mK	20mK
Evap. heat switch	TBD	CX-1050	1K>50K	10mK	20mK
Phot Point Stim.	TBD	CX-1070	3K>80K	5mK	20mK
BSM/SOB I/F	TBD	CX-1070	3K>300K	50mK	100mK
SMEC Mechanism	TBD	CX-1050	3k>20K	25mK	50mK
BSM	TBD	CX-1050	3k>20K	25mK	50mK
Input Baffle	TBD	CX-1050	3k>20K	25mK	50mK

*NTD Ge Thermistor is equivalent to a detector element, but it is not mounted on an isolating web.

5.7.5.2 Shutter Temperature Sensors

Handled by EGSE, not FCU/DPU, and therefore included here only for completeness. Not available for flight.

Location IN HSFPU	Acronym	Sensor Type	Temp. Range	Resolution	Acc.
Shutter Vane-A	TBD	CX-1070, TBC	3K>80K	5mK	10mK
Shutter Vane -B *	TBD	CX-1070, TBC	3K>80K	5mK	10mK
Shutter Actuator-A *	TBD	CX-1070, TBC	3K>120K	25mK	500mK
Shutter Actuator-B *	TBD	CX-1070, TBC	3K>120K	25mK	500mK

5.7.5.3 Satellite Temperature sensors

In addition to the **Spire** conditioned temperature channels, **Spire** requires that HERSCHEL itself shall monitor the temperatures of certain locations on the cryostat and SVM. These are given in the table below.

Location	Sensor Type	Temp. Range	Acronym	Resolution*	Acc.
Level 0 Strap A to cooler	ESA TBD	1.5K to 90°C	TBD	10-500mK	TBD
Level 0 Strap B to cooler	ESA TBD	1.5K to 90°C	TBD	10-500mK	TBD
Level 0 Strap to HSFPU 1.8k boxes	ESA TBD	1.5K to 90°C	TBD	10-500mK	TBD
Level 1 strap to HSFPU	ESA TBD	1.5K to 90°C	TBD	10-500mK	TBD
HSJFS mounting temperature	ESA TBD	1.5K to 90°C	TBD	10-500mK	TBD
HSJFP mounting temperature	ESA TBD	1.5K to 90°C	TBD	10-500mK	TBD
HOB at HSFPU centre foot	ESA TBD	1.5K to 90°C	TBD	10-500mK	TBD
HOB at HSFPU +Y foot	ESA TBD	1.5K to 90°C	TBD	10-500mK	TBD
HOB at HSFPU -Y foot	ESA TBD	1.5K to 90°C	TBD	10-500mK	TBD
Centre SPIRE SVM panel.	ESA TBD	-80 to 90°C	TBD	0.4K	1K

*Lower values applies at bottom end of range. When hot, accuracy requirement is much less stringent.

The precise number an location of these sensors shall be confirmed after thermal modelling.

HERSCHEL shall check temperatures are within range, and for instance not empower SVM units outside of their rated operating ranges.

5.8 OPTICAL INTERFACES

Spire's only optical interface is that toleranced in section 5.3.2. The instrument's optical design is now frozen and well analysed, see AD xxxx.

For information, figures 5.8-1, 5.8-2, 5.8-3, 5.8-4 and 5.8-5 show the **Spire** optical beam envelope at various places through the path from the telescope focal plane to the hole in the HERSCHEL primary mirror. No structure or other material is allowed within the envelope defined by these "footprints". A definitive full analysis taking diffraction into account is given in AD????

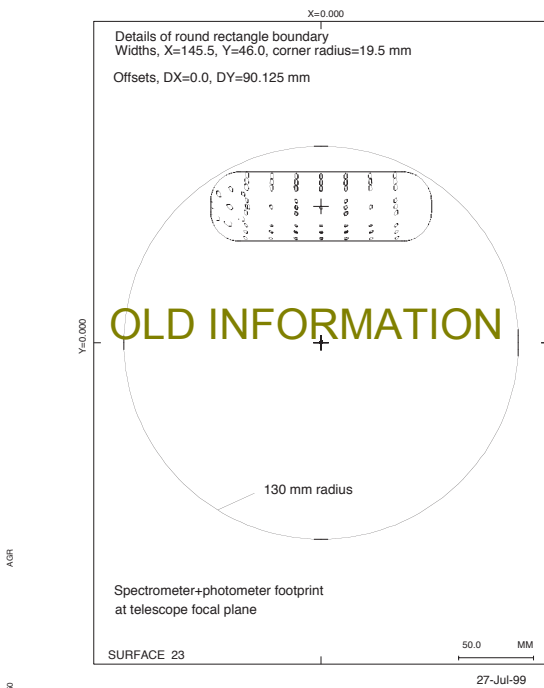

Reversed PHOT126B + SP460C
 Figure 5.8-1 **Spire** optical beam envelope at the telescope focal plane.

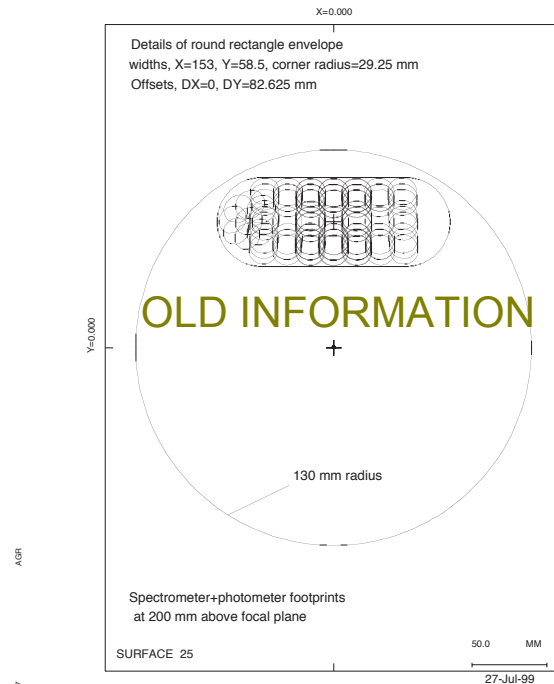

Reversed PHOT126B + SP460C
 Figure 5.8-3 **Spire** optical beam envelope at 200 mm above telescope focal plane.

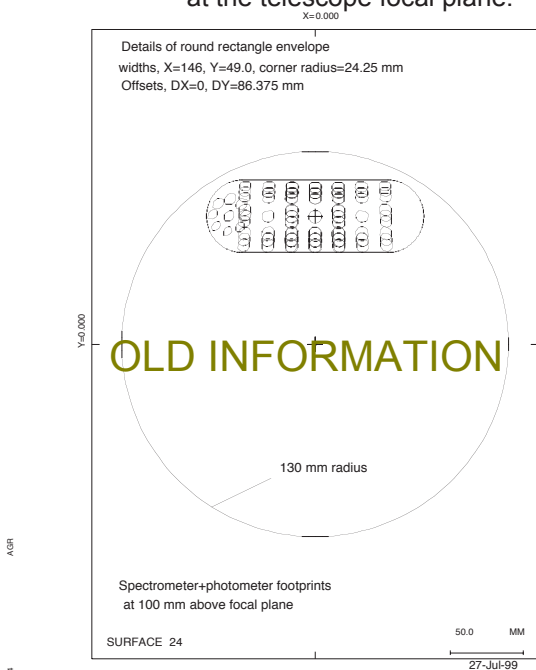

Reversed PHOT126B + SP460C
 Figure 5.8-2 **Spire** optical beam envelope at 100 mm above telescope focal plane.

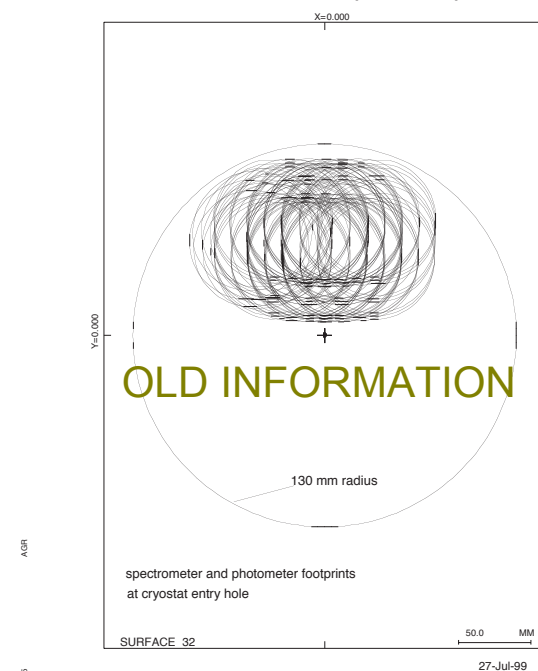

Reversed PHOT126B + SP460C
 Figure 5.8-4 **Spire** optical beam envelope at the exit hole from the HERSCHEL cryostat.

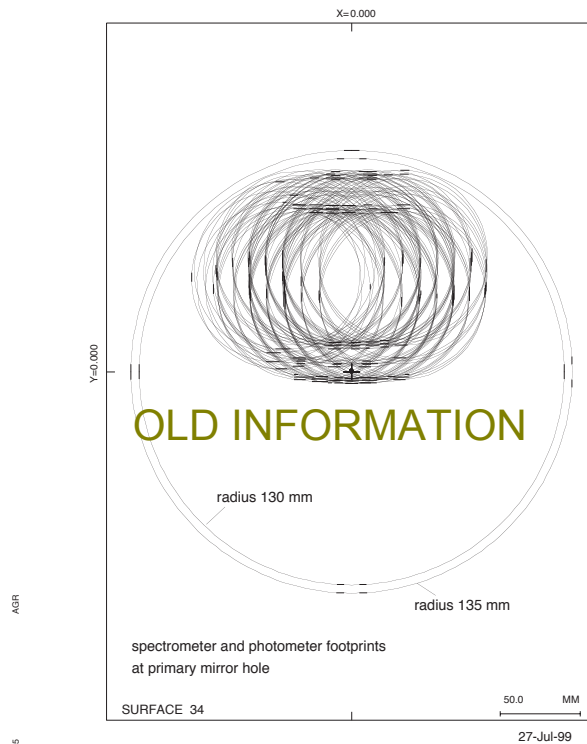

Figure 5.8-5 **Spire** optical beam envelope at the hole in the HERSCHEL telescope primary mirror

Note that the spectrometer's used beam lies next to that of the photometer although more off-axis, and that optically both are illuminated simultaneously although they then view different places on the sky; beam switching is not used.

The above diagrams will shortly be updated, but the implications are already accounted for. |

5.8.1 Straylight

The instrument straylight model and its conclusions for alignment etc. are described in RDxxxx.

5.9 POWER

5.9.1 Inside cryostat

The whole situation is specified in great detail in the Thermal Configuration Control Document, Adxxxx.

The following table is for the configuration presented at IIDR. It is noted that fast adjustment of cryostat boil-off rate to match load is unrealistic, and also the IID-A has yet to apportion heat load properly across the instruments and their various modes.

PARAMETER	Heat Load Estimate (mW)			
	PHOT	SPEC	STNDBY	OFF
Level 2 Summary				
HEAT LOAD ON SPIRE L2:	49.5	14.1	49.5	0.0
ESTIMATED HEAT LEAK FROM SPIRE L2 TO L1:	12.58	7.46	12.88	6.25
ESTIMATED HEAT LOAD ON HERSCHEL L2:	36.95	6.66	36.65	-6.24
IID-A MAXIMUM AVERAGE HEAT LOAD BUDGET TO HERSCHEL L2:	50	50	50	50
Level 1 Summary				
ESTIMATED HEAT LOAD ON SPIRE L1:	16.68	15.86	12.89	6.25
ESTIMATED HEAT LEAK FROM SPIRE L1 TO L0:	4.22	3.79	3.51	1.92
ESTIMATED HEAT LOAD ON HERSCHEL L1 STRAP:	12.46	12.07	9.37	4.34
IID-A MAXIMUM AVERAGE HEAT LOAD BUDGET TO HERSCHEL L1:	25	25	25	25
L0 Summary				
ESTIMATED HEAT LOAD ON SPIRE L0:	4.419	3.993	3.513	1.923
ESTIMATED HEAT LEAK FROM SPIRE L0 TO 300mK STAGE:	0.024	0.024	0	0
ESTIMATED HEAT LOAD ON HERSCHEL L0 STRAPS:	4.405	3.980	3.524	1.928
IID-A MAXIMUM AVERAGE HEAT LOAD BUDGET TO HERSCHEL L0:	10	10	10	10

Excludes conducted and dissipative heatloads from cryoharness connecting to 300 K level.

Includes dissipation of ³He refrigerator when operating (Averaging the load during operation and recycling – recycle mode dissipates 90 mW (TBC) for 2 out of every 48 hours). The parasitic loads from 4 to 2 K through the structure and heat switches amount to 1 mW (TBC).

5.9.2 Outside Cryostat

NA

5.9.3 On SVM

The table shows the heat dissipation of the units mounted on the SVM in Watts. Note that by comparison power passed through to the Cryoharness and HSFPU is negligible, so these dissipations are also the value of power supplied:

Unit	Estimate	Spire Internal Budget	Contingency %	Budget + Cont.	Via HPLCL see figure 5.2.1
HSDPU	24	15	20	18	A-P or A-R
HSFCU+HSDCU	67	71	20	85.2	B-P or B-R
HSWIR	<0.1	0	0	0	
TOTAL		86		103.2	

These apply to all modes, and the baseline is to only empower either prime or redundant in **Spire**. The instrument appears to the S/C as simply cold redundant.

5.9.4 On Planck Payload Module

NA

5.9.5 Power versus Instrument Operating Modes

The table below shows the status of the instrument subsystems in the various instrument modes.

Unit	Subsystem	Recycle	Off	On	Standby/ Parallel/ Serendipity	Observe	
						PHOT	SPEC
HSFPU	Detector Bias	OFF	OFF	OFF	ON	ON	ON
	Photometer Cal Source	OFF	OFF	OFF	OFF	X	OFF
	Spect Cal Source	OFF	OFF	OFF	OFF	OFF	ON
	Cooler	ON	OFF	OFF	ON	ON	ON
	BSM	OFF	OFF	OFF	ON	ON	ON
	FTS Mechanism	OFF	OFF	OFF	OFF	OFF	ON
HSFTB	JFET amplifiers	ON	OFF	OFF	ON	ON	ON
HSFCU + HSDCU	Read-out electronics & Mechanism drive Electronics	ON	OFF	OFF	ON	ON	ON
FSDPU	Digital Processing Unit	ON	OFF	ON	ON	ON	ON

ON =	Operational;
OFF =	Inactive;
X =	Either ON or OFF depending on instrument configuration.

5.10 POWER BUS INTERFACES.

5.10.1 28 Volt main-bus

5.10.1.1 Load on main-bus

The total power load **Spire** places on the 28V main-bus is defined In the **Spire** Budgets' Document. The following is an extracted summary:

Operating mode	Average BOL (beginning of life) (W)	Average EOL (end of life) (W)	Peak (W)
Observe	86 W	TBD	TBD
Parallel	86 W	TBD	TBD
Serendipity	86 W	TBD	TBD
Standby	86 W	TBD	TBD
Cooler Recycle	86 W	TBD	TBD
On	15 W	TBD	TBD
Off	0	0	0

5.10.1.2 Power Nominal Turn-on.

Having checked that **Spire** is all unpowered, the HPCDU shall empower an HSDPU(P or R). This DPU checks that its health and sends a status packet on the active 1553 bus. If status is OK, HCDMU causes HPCDU to turn on corresponding HSFCU (P or R). Note that turning on the HSFCU has the automatic subsidiary effect of turning on the non-redundant DCU, but this unit is not seen directly via a S/C interface.

5.10.1.3 Interface circuits

The HSDPU and the HSFCU receive both prime and redundant 28V feeds. The configuration is shown in figure 5.2.1, and the connectors are DPU J1-2 and FCU J5-6.

Their S/C power interfaces circuits shall be designed not to generate unwanted interaction with LCL switching limiters.

The HPCDU shall telemeter LCL current to better than 0.30mA resolution.

5.10.1.4 LCL fault conditions

Powering both FCUs simultaneously is not a condition that the S/C shall allow, even in the event of a single point LCL failiure.

Both DPUs may be powered but only under LCL fault conditions. To permit this, other design features must be present. The unwanted although powered DPU shall be kept inactive by not commanding the inactive unit, and neither HCDMU shall turn on the corresponding HSFCU. To permit commanding the DPUs to work like this, each HSDPU use a different 1553 bus address.

The HERSCHEL platform shall monitor that LCL's are behaving correctly. With certain timing restrictions, it shall regularly check that an "off" LCL is passing less than a minimum current, and that an "on" LCL is passing a current between a minimum and a maximum that depends on circuit. It shall re-check this before and after implementing a command to change an LCL's state. The formal status of the functionality of LCLs [working, stuck on, stuck open-circuit, dubious, etc.] shall be stored somewhere in the HERSCHEL commanding system (probably on the ground?) to stop any attempt to switch a failed LCL without specific over-ride .

An open-circuit LCL is not a particularly difficult case to consider as it would just preclude the use of one side of **Spire**.

5.10.1.4.1 HSDPU Power Input Circuit Configuration

TBD

5.10.1.4.2 HSFCU Power Input Circuit Configuration

TBD

5.10.2 Keep Alive Line (KAL)

Because **Spire** should not be switched-on/off frequently, a KAL will not be implemented.

5.11 ELECTRICAL SIGNAL INTERFACES

5.11.1 1553 Data Buses

The 4 interfaces to the two (prime and redundant) buses between the **Spire** instrument DPUs and the CDMU shall conform to MIL-STD-1553B, with the CDMU controlling the bus.

The 4 **Spire** interfaces shall have unique bus addresses, consistent with HERSCHEL properly controlling the use of Prime and Redundant equipments.

A long stub configuration shall be used for each of the 4 interfaces, one transformer for each stub in the bus wiring and one in the instrument I/F.

Connector use is as follows:

DPU Connector	Prime Bus	Redundant Bus
Prime DPU	J3	J4
Redundant DPU	J5	J6

5.11.2 Master Clock

HERSCHEL shall supply 2 differential signal lines of 2^{17} Hz. master clock signals. They are therefore supplied unground-referenced. These are shown as brown lines in figure 5.2.1.

Electrical interface details are standard digital differential receiver, through DPU connectors J3 and 5, i.e. bundled with primary 1553 bus.

This shall be supplied to both powered and unpowered **Spire** units.

Note that HERSCHEL arranges the OR-ing of the functions over Prime and Redundant CDMU so that **Spire** is unaffected by which one is active.

Older documentation may have references to S/C wide synchronisation of dc-dc convertors, etc., but this will NOT be implemented.

5.11.3 Launch confirmation

Spire has three cryogenic mechanisms: BSM; SMEC; shutter. It is baselined that each will need to be launch-locked and will feed isolated SPST micro-switch contacts to HERSCHEL to confirm this, linking to the HCDMU's RTU inputs.

There will thus be six pairs of these contacts, 3 mechanisms X [wired via prime harness and wired via redundant cryoharness].

HERSCHEL should check each of their states using <10V and <2mA as part of the early launch procedures.

Connectors used are FCU J26 -27, which are used in flight for this purpose but also for different functions during instrument level test.

5.12 CONNECTORS, HARNESS, GROUNDING, BONDING

5.12.1 Harness and Connectors

Spire harnesses are shall be as defined in Adxxxx, which needs to have harness length incorporated as soon as details are agreed. For information, the following configuration is extracted from the document.

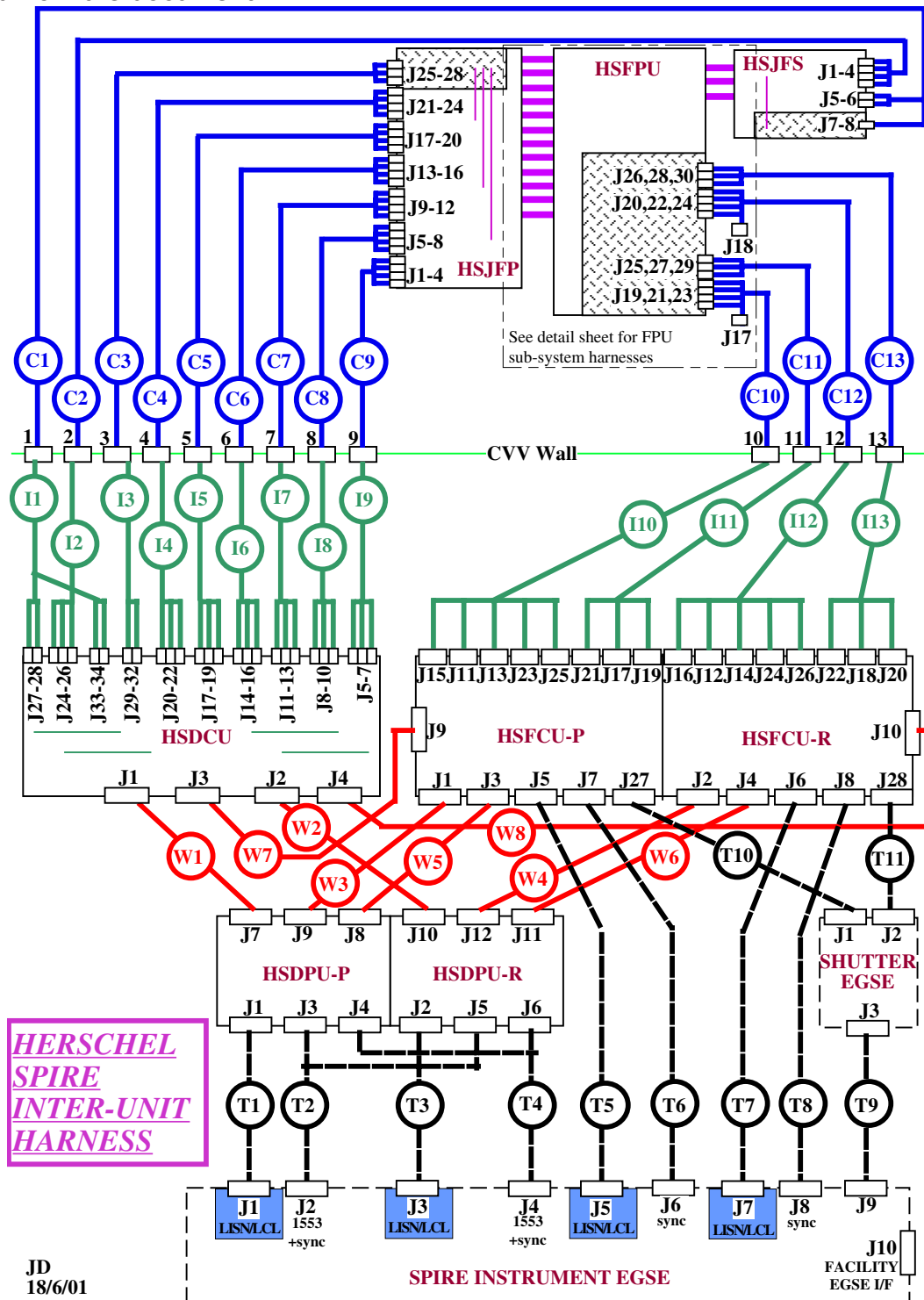

Note that the Cryo-harness, i.e. series C and I, are ESA provided and not **Spire** flight H/W, whilst the T series apply only for instrument test and are not **Spire** flight items.

5.12.2 Grounding

The **Spire** grounding scheme is worked through in ADxxxx. This will be essential to the satisfactory performance of the instrument, it being vital that interfaces do not cause energy to be dissipated in the 300mK section and particularly not in the bolometers themselves.

For information, the following configuration is extracted from the above-mentioned document.

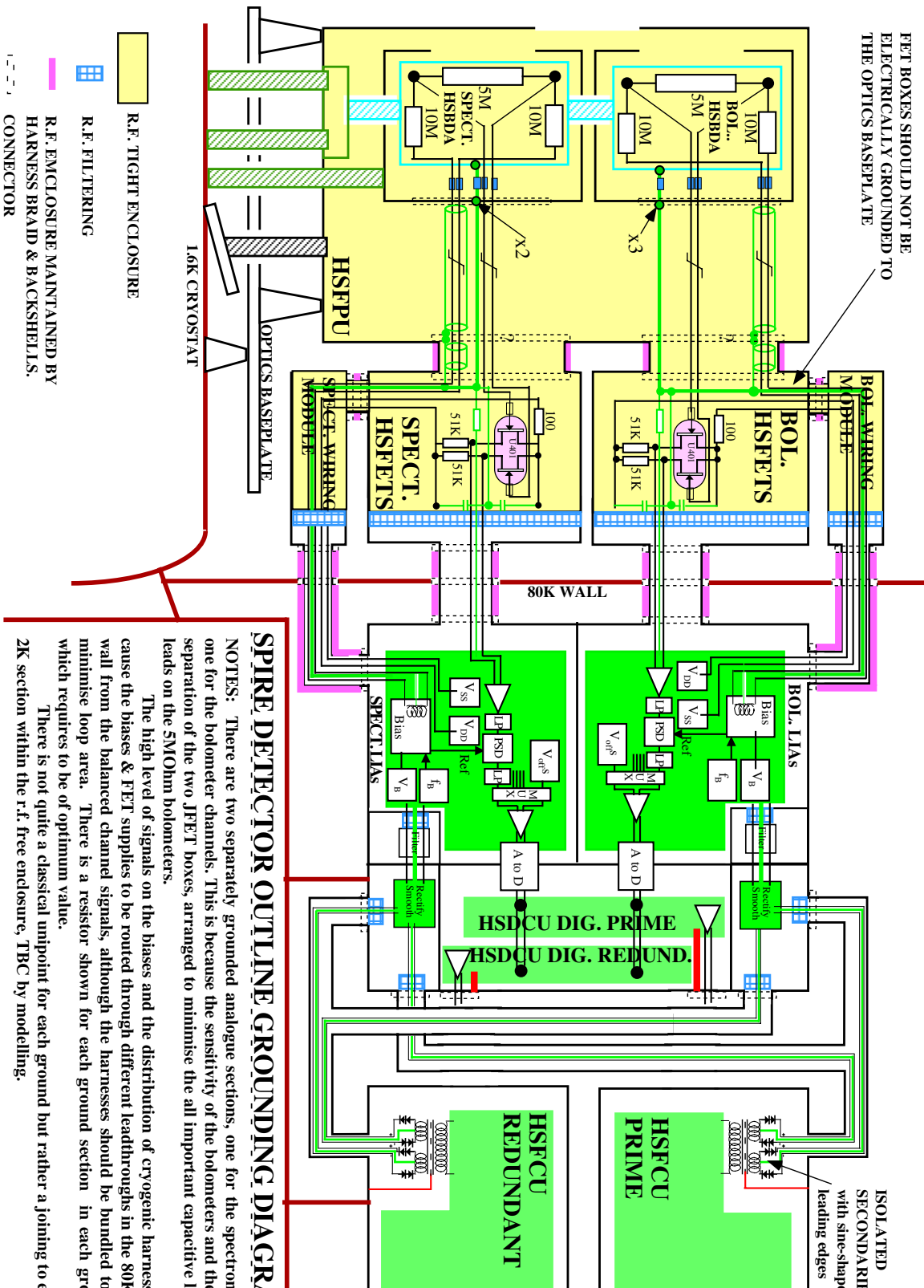

The **Spire** FCU itself and the DPU use a "standard" ESA-type secondary power system, whereas the DCU/FPU and FCU supply sections shown above are an optimised system w.r.t. minimising the overall bolometer analogue ground noise. The FCU powers the DCU, keeping the latter free of conditioning noise. The FCU driven items in the FPU, see figure 5.2.1, are considered less critical and will all be Ohmically grounded in the FPU.

Ohmic isolation is baselined within all straps to the cryostat, $>5\text{M}\Omega$ and $<50\text{pF}$ at the working temperature. Note that this isolation is within the strap system, that is a HERSCHEL not a **Spire** element, would seemingly be common to all straps, and of the proven qualified ISO design. It should not form part of the instrument I/F itself.

5.12.3 Bonding

It is understood that HERSCHEL bonding applies to harness shields used to maintain closed Faraday cages. Bonded interfaces shall not be used as routine current return paths.

We note that presently all Warm Electronics units rely in conductivity via their mechanical mounting feet to S/C. **Spire** would much prefer a formal S/C aluminium strap bounding tree, coupled by controlled straps to all equipments, and will therefore provide a bounding strap mounting point on each SVM mounted unit to permit this.

5.13 DATA HANDLING

5.13.1 Telemetry

5.13.1.1 Telemetry rate

The instrument produced “raw” housekeeping and science data rates, given for information purposes, are as follows:

Description	Data rate (Kbps)
Housekeeping data rate (non-prime)	2.1
Housekeeping data rate (prime)	2
Science data rate: Photometer only	93.6
Science data rate: Spectrometer only	97.4
Science data rate: Parallel mode	10
Science data rate: Serendipity mode	87

Any increase in telemetry rate would have science benefits. Note that the data rate allocation of 100Kbps is a limit on the average including orbit recycling/commanding periods

5.13.1.2 Data-bus rate

For the purpose of possible (up to 5 minutes) higher instrument data-rates, the bus interconnecting the instrument and the HCDMU shall have the capability of handling a telemetry rate of > 200 kbps. This will allow for the rapid emptying of **Spire** on-board data storage units at the end of each observation, thus keeping overheads due to data transfer to a minimum.

5.13.1.3 Data Packets

Spire is capable of buffering 10 seconds of data at 100kps. In order to prevent data overflow in this **Spire** data storage, the HVDMU shall request packets from **Spire** at least as frequently as once per second(TBC).

5.13.2 S/C housekeeping

The S/C should be capable of collecting and range checking the following instrument parameters every minute. It shall provide a data packet to the ground that includes these housekeeping values, together with any range violations and any actions taken thereon.

Voltages to instrument

Currents to instrument

Power status – i.e. which **Spire** units are on i.e. FSDPU and FSDRC.

Requested temperatures in Section 5.7.5.2.

5.13.3 Timing and synchronisation signals

The S/C shall provide **Spire** with a timing synchronisation at least once per 24 hours to allow cross reference or synchronisation of the **Spire** clock to the spacecraft clock.

Spire requires to be able to deduce where HERSCHEL is pointing to 0.1 of its smallest pixel IFOV. So when using the telescope scan mode, a “start of scan” indication will be sent to the DPU to give a timing precision of better than 5TBC milliseconds. This is required so that the **Spire** data can be located in time and correctly ground processed to link to HERSCHEL attitude; it is not required for the operation of the **Spire** instrument.

The **Spire** instrument typically works by its DPU unpacking S/C commands to a lower level, and sending those lower level commands to the DCU and FCU with timings that they can guarantee to keep up with. There is a minimum of handshaking on internal interfaces and, for instance, the DPU has to be ready to receive science data packets from the DPU and FCU whenever they reasonably send them. In these internal data packet headers are counter values permitting accurate datation of all values back to sequence start pulses sent from the DPU. The scheme can be viewed as:

SPIRE DATA TIMINGS

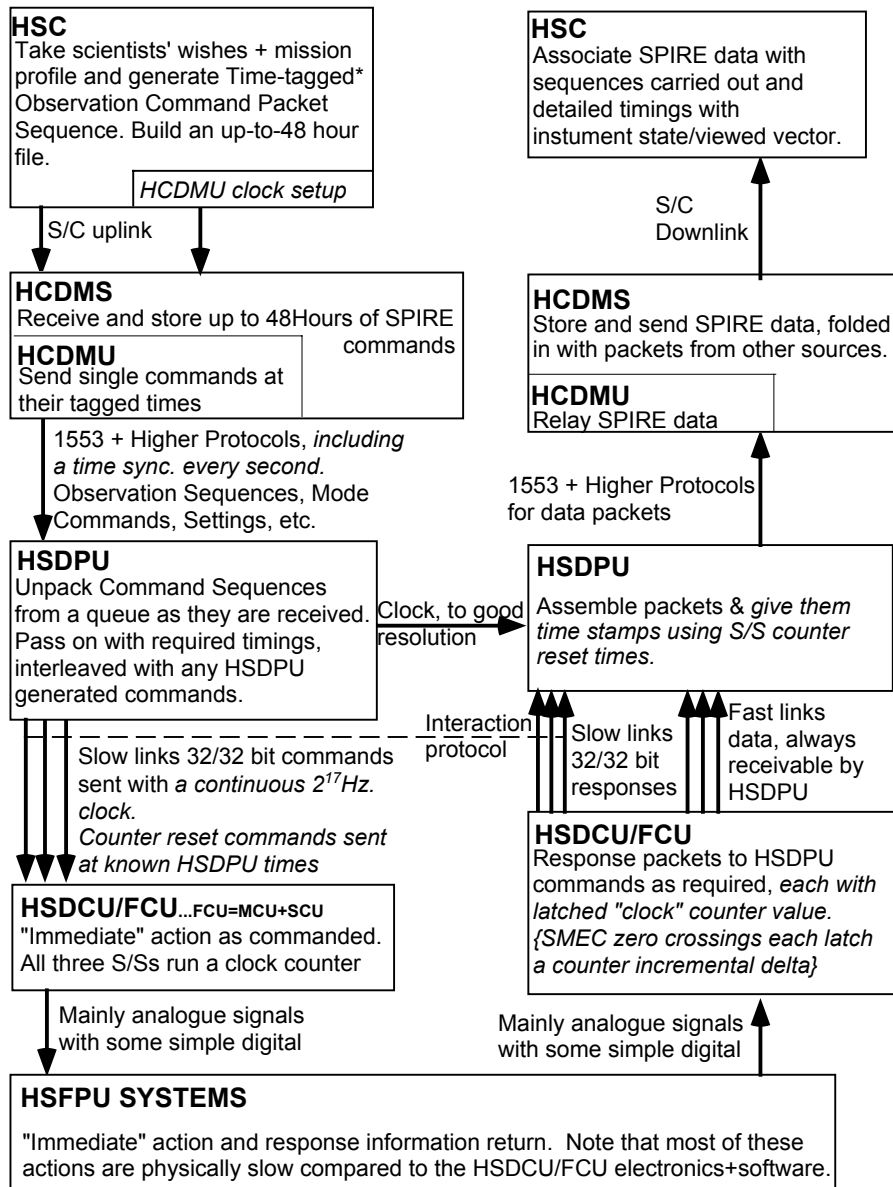

*This process uses known worst case timings for SPIRE operation + margin to ensure that the plan can be implemented and timed starts will not slip.

Note that for the above scheme to work, either the DCU/MCU/SCU need to have no input FIFOs, or the DPU needs to know that they are empty and a reset will go straight through, or these units need to check for the reset pulse in hardware before feeding other packets into a FIFO. TBD.

5.13.4 Telecommand

It is assumed that the observation schedule for each 24 hour period will be uplinked during the data transfer and commanding phase (DTCP). It is further assumed that the correct receipt of all **Spire** commands is verified by the S/C during the DTCP.

The maximum rate of sending command packets from the CDMS to the **Spire** instrument is less than 10 per second.

The maximum telecommand packet length is 256 octets.

All **Spire** telecommands are defined in document ADxxxx.

5.14 ATTITUDE AND ORBIT CONTROL/POINTING

5.14.1 Attitude and orbit control

For information, **Spire** has the following instrument pointing modes:

- Peak up mode. The ACMS pointing ability quoted in the IID-A (3.7 arcsec APE – see also section 5.12.2) will not be good enough to prevent unacceptable signal loss when observing point sources with the photometer or spectrometer. The **Spire** beam steering mirror will be used to perform a cruciform raster over the observation target and the offset between the required pointing and the actual pointing of the telescope will be provided via an ACMS Data Packet from the **Spire** instrument to the S/C. The S/C will then adjust the pointing accordingly.
- Nodding mode. If the telescope temperature stability time constant proves to be short compared with a typical pointed observation with **Spire**; then the telescope must be capable of being pointed to another fixed position on the sky between 10 arcsec and 4 arcmin from the original pointing in an arbitrary direction with respect to the spacecraft axes. The settling time at each re-pointing must be less than 10 seconds
- Line scan mode. To map large areas of the sky, the telescope must be capable of being scanned up to 20 degrees at a constant rate in an arbitrary orientation with respect to the spacecraft axes. The rate of scan must be variable between 0.1 arcsec/sec and 60 arcsec per second. It is expected that the RPE will be maintained in the orthogonal direction during the scan. The S/C must be capable of reaching any scan speed up to the maximum within 20 seconds of the observation commencing.
- Raster mode. To finely sample the **Spire** FOV the instrument beam steering mirror will be used to step the FOV across the sky in an arbitrary direction. The step size will be between 1.7 arcsec and 30 arcsec. The beam steering mirror can also be used to chop a portion of the **Spire** FOV at a rate up to 2 Hz.

The S/C is specified as being able to perform its own raster mode, i.e. stepping the FOV of the overall HERSCHEL telescope view to follow predetermined patterns. This is acknowledged to be much less efficient than using the internal Beam Steering Mirror (BSM), but is needed as a backup in the event of **Spire** BSM failure. The spacecraft shall be capable of performing a rectangular raster with steps of between 1.7 and 30 arcsec in any arbitrary orientation with respect to the S/C axes.

To map extended regions using the spectrometer, the **Spire** instrument will use the HERSCHEL telescope Normal Raster Mode. The instrument may perform fine sampling of each raster pointing using its internal BSM.

5.14.2 Pointing

The **Spire** instrument requires an absolute pointing error of better than 1.5 arcsec r.m.s. (TBC), and a relative pointing error of better than 0.3 arcsec r.m.s. per minute.

This is achieved by the peak up mode in case the pointing goal values are not fully achieved by the S/C.

5.14.3 On-Target Flag (OTF)

For pointed observations, within about a second of an acquisition being achieved an On-Target Flag will be provided from the platform to **Spire** as a message on the 1553 bus, specifying the acquisition time to a precision of better than 0.1 second. This is required for the correct processing of the **Spire** data on the ground; it is not required for **Spire** operations.

5.15 ON-BOARD HARDWARE/SOFTWARE AND AUTONOMY FUNCTIONS

5.15.1 On-board hardware

There is a single on-board computer in each of the prime and redundant **Spire** HSDPUs. These have the only non-hardcoded on-board software used in **Spire**.

5.15.2 On-board software

It is assumed that the **Spire** warm electronics will remain powered during all operational phases. The DPU will download baseline software from ROM during power up but some additional software may be required (TBD) to be unlinked before observations commence, either patches or whole modules/objects.

No single instrument command nor any sequence of instrument commands will constitute a hazard for the instrument so the HSDPU is required to trap out any such situations. For the same reason, the HSDPU shall ensure its own correct function, at least as far as checking memory function in the background, checksummed read only areas, and an inhibitible SEU safing capability.

5.15.3 Autonomy functions

The S/C must be capable of automatic monitoring all Spacecraft Housekeeping parameters, i.e. the parameters listed in section 5.7.5.2 when the S/C is not in ground contact.

The S/C must also be capable of monitoring certain **Spire** Instrument Housekeeping parameters provided to it via “Housekeeping Data” packets from the **Spire** DPU – see 5.7.5.1.

The S/C must be capable of taking predefined action – e.g. switching off the power to the **Spire** instrument – when an error or hard limit is detected in either the **Spire** S/C Housekeeping or the **Spire** Instrument Autonomous Housekeeping parameters.

The S/C must be capable of receiving and interpreting **Spire** “Event Data” packets that will alert the S/C of errors or hard limits detected by the **Spire** DPU autonomy monitoring software. Again the S/C must be capable of taking the appropriate pre-defined action on detecting an error alert in the **Spire** Event Data.

5.15.4 Instrument Autonomy Housekeeping Packet Definition

TBD

5.15.5 Instrument Event Packet Definition

TBD

5.16 EMC

5.16.1 Conducted Emission/Susceptibility

None to be found under required test conditions

5.16.2 Radiated Emission/Susceptibility

None to be found under required test conditions

5.16.3 Frequency Plan

The original specification for **Spire** to have all its internal oscillators for signal/power synchronised to S/C sync. signals has been dropped.

The **Spire** frequency plan will be associated with the DRCU. It will show how all the DRCU frequencies are arranged to minimise noise problems in the bolometer sub-system's highly sensitive analogue sections.

5.17 TRANSPORT AND HANDLING PROVISIONS

5.17.1 Focal Plane Unit

5.17.1.1 Transport Container

The **Spire** FPU (FSFPU) will be transported in a clean hermetically sealed container to be opened only in class 100 clean conditions (TBC) with less than 50% humidity (TBC).

The maximum shock the FSFPU can sustain in any direction is (TBD). The transport container is fitted with shock recorders and internal humidity monitors. The FSFPU transport container is shown in figure TBD.

5.17.1.2 Cooling and Pumping restrictions

During cryostat warm-up or cool-down phases the rate of temperature change dT/dt shall not exceed 10 K/hour (TBC). The rate of depressurisation/pressurisation dP/dt shall not exceed 50 mBar/minute (TBC).

5.17.1.3 Mechanism positions

For reasons of possible damage caused by vibration during transport, environmental testing and launch, mechanisms shall be placed in the TBD position. This position is shown in table TBD.

5.17.1.4 Unpacking Procedure

The procedure for removing and installing the FSFPU from its transport container is given in document TBW

5.17.2 JFET/Filter Boxes

5.17.2.1 Transport Container

The **Spire** JFET/Filter Boxes (HSFTP/S) will be transported in a clean hermetically sealed container to be opened only in class 100 clean conditions (TBC) with less than 50% humidity (TBC).

The maximum shock the HSFTP/S can sustain in any direction is (TBD). The transport container is fitted with shock recorders and internal humidity monitors. The HSFTP/S transport container is shown in figure TBD.

5.17.2.2 Unpacking Procedure

The procedure for removing and installing the HSFTP/S from its transport container is given in document TBW

5.17.3 Electronics Units

5.17.3.1 Transport Container

The **Spire** warm electronics units (HSDPU; HSFCU; HSDCU, HSWIH) will be transported in clean hermetically sealed containers to be opened only in class 100000 clean conditions (TBC) with less than 75% humidity (TBC).

The maximum shock any of the warm electronics units can sustain in any direction is (TBD).

The transport containers are fitted with shock recorders and internal humidity monitors.

The **Spire** warm electronics transport containers are shown in figure TBD.

5.17.3.2 Unpacking Procedure

The procedures for removing and installing the **Spire** from warm electronics units their transport containers are given in document TBW

5.18 DELIVERABLE ITEMS

5.18.1 Instrument Models.

The model philosophy to be adopted for the AIV of the HERSCHEL **Spire** instrument will be in accordance with the **Spire** Development Plan and Model Philosophy, ADxxxx.

In outline, the instrument models to be produced are:

AVM – The Avionics Model shall permit us “...to validate electronics and software for its interface with the S/C, including anything that exchanges information with, for example, the AOCS. In addition all tasks relevant to **Spire** autonomy shall be verified.” This requires a DPU in at least form, fit and function plus a simulator of the DRCU and cold FPU – collectively termed the DRCU Simulator. As the schedule demands that this model will be delivered almost simultaneously with the CQM, it is planned to use the CQM DPU in the AVM.

CQM - Cryogenic Qualification Model. For both the cold FPU and the warm electronics it is assumed that this is built to flight standards, but not necessarily using flight quality electronic components. The performance capabilities of the instrument may be less than the proto-flight model - i.e. fewer pixels in the focal plane arrays, but it will mimic as exactly as possible the thermal, electrical and mechanical properties of the flight instrument and will be capable of under going the full environmental qualification programme

PFM – Proto-Flight Model. This will be the model that is intended for flight, built to full flight standards. The PFM will therefore undergo environmental test to qualification levels for acceptance times (TBD) - this applies to both the warm electronics boxes and the cold FPU. A CQM qualification review will determine if in fact the PFM has needed sufficient updates that full requalification is needed in some respects.

FS – Flight Spare. The flight spare cold FPU will be made from the refurbished CQM (TBC). The flight spare warm electronics will consist of spare electronics cards/modules/harness.

5.18.2 Electrical Ground Support Equipment (EGSE)

Electrical Ground Support Equipment (EGSE) will be needed to provide **Spire** instrument level monitoring during instrument integration with the S/C and system level testing.

Deliverables:

- FPU electrical simulator, including simulation of the HSFTP/S, to enable integration of the HSDCU, HSDPU, HSFCFU and HSWIH
- TBD EGSE for integration of the HSFPU
- Quick Look Facility to enable testing of the instrument at system level. This will interface to the S/C test environment

5.18.3 Mechanical Ground Support Equipment (MGSE)

MGSE is required to ensure safe handling of all instrument components during assembly integration and test procedures.

Deliverables:

- Transport containers
- Instrument to cryostat integration jigs/equipment
- Plus TBD

5.18.4 Optical Ground Support Equipment (OGSE)

OGSE is required to carry out alignment procedures with the telescope.

Deliverables:

- Instrument optics primary alignment and alignment verification jigs/equipment
- Plus TBD

5.18.5 System Test Software

Will be based on the Quick Look Facility - computers and software that allow the monitoring in near real time of the instrument housekeeping parameters and instrument data. This is the basic facility to be used for the ICC operations monitoring for the monitoring of the instrument in-orbit. The same facility with enhanced capabilities will be used for the ground tests and in-orbit check out of the instrument.

5.18.6 Hardware for the Observatory Ground Segment

Quick Look Facility for the Mission Operations Centre for instrument in-flight commissioning. This will consist of TBD workstations etc....and must be identical to the system used for instrument system level testing.

5.18.7 Software for the Observatory Ground Segment

The software for the Quick Look Facility will be delivered to the MOC for instrument in-flight commissioning.

Plus TBD.

5.18.8 Instrument Software Simulator

TBD

5.18.9 Test Reference Data

The **Spire** instrument test reference data will be delivered in the TBD form generated during instrument and system level testing.

5.18.10 Instrument Characterisation Data

The **Spire** instrument characterisation data will be delivered in the TBD form generated during instrument and system level testing.

5.18.11 Technical Documentation

The following documents will be delivered:

- Instrument User Manual following the requirements laid down in the OIRD (AD2)
- Instrument database – this will be delivered in the TBD form generated during instrument and system level testing.
- Each instrument model will be delivered with an Acceptance Data Package consisting of TBD...a good way to end a document.