

Chapter 5 Contents.

5	INTERFACE WITH SATELLITE	5-4
5.1	IDENTIFICATION AND LABELLING	5-4
5.2	INTERFACE LOCATIONS.....	5-4
5.2.1	MECHANICAL COORDINATE SYSTEM.....	5-6
5.3	LOCATION AND ALIGNMENT	5-6
5.3.1	Instrument Location	5-7
5.3.2	Instrument Alignment.....	5-7
5.4	EXTERNAL CONFIGURATION DRAWINGS	5-8
5.4.1	FSFPU.....	5-8
5.4.2	HSSJF	5-10
5.4.3	HSPJF	5-10
5.4.4	SVM Mounted Units.....	5-10
5.5	SIZES AND MASS PROPERTIES	5-11
5.5.1	Mass on HERSCHEL Optical bench.....	5-11
5.5.2	Mass on Service Module	5-12
5.5.3	Moments of Inertia and C. of Gs.	5-12
5.6	MECHANICAL INTERFACES	5-13
5.6.1	Inside cryostat	5-13
5.6.2	Outside Cryostat.....	5-13
5.6.3	On SVM.....	5-13
5.6.4	On Planck Payload Module	5-13
5.6.5	Cooler valves and piping	5-13
5.7	THERMAL INTERFACES.....	5-14
5.7.1	Inside cryostat	5-14
5.7.2	Outside Cryostat.....	5-15
5.7.3	On SVM.....	5-16
5.7.4	On Planck Payload Module	5-16
5.8	Temperature channels.....	5-17
5.9	OPTICAL INTERFACES.....	5-19
5.9.1	Straylight.....	5-20
5.10	POWER.....	5-21
5.10.1	Inside cryostat	5-21
5.10.2	Outside Cryostat.....	5-21
5.10.3	On SVM.....	5-22
5.10.4	On Planck Payload Module	5-22
5.10.5	Power versus Instrument Operating Modes.....	5-22
5.11	POWER BUS INTERFACES.....	5-23
5.11.1	28 Volt main-bus.....	5-23
5.11.2	Keep Alive Line (KAL).....	5-23
5.12	ELECTRICAL SIGNAL INTERFACES.....	5-24
5.12.1	1553 Data Buses	5-24
5.12.2	5-24	
5.12.3	Synchronisation	5-24
5.12.4	Launch confirmation	5-24
5.13	CONNECTORS, HARNESS, GROUNDING, BONDING	5-25
5.13.1	Harness and Connectors	5-25
5.13.2	Grounding.....	5-26
5.13.3	Bonding	5-27
5.14	DATA HANDLING	5-28

5.14.1	Telemetry.....not updated.....	5-28
5.14.2	S/C housekeeping	5-28
5.14.3	Timing and synchronisation signals	5-28
5.14.4	Telecommand.....	5-30
5.15	ATTITUDE AND ORBIT CONTROL/POINTING.....	5-31
5.15.1	Attitude and orbit control.....	5-31
5.15.2	Pointing.....	5-31
5.15.3	On-Target Flag (OTF).....	5-31
5.16	ON-BOARD HARDWARE/SOFTWARE AND AUTONOMY FUNCTIONS	5-32
5.16.1	On-board hardware.....	5-32
5.16.2	On-board software.....	5-32
5.16.3	Autonomy functions	5-32
5.16.4	Instrument Autonomy Housekeeping Packet Definition	5-32
5.16.5	Instrument Event Packet Definition.....	5-32
5.17	EMC.....	5-33
5.17.1	Conducted Emission/Susceptibility.....	5-33
5.17.2	Radiated Emission/Susceptibility.....	5-33
5.17.3	Frequency Plan	5-33
5.18	Transport and Handling Provisions.....	5-34
5.18.1	Focal Plane Unit	5-34
5.18.2	JFET/Filter Box.....	5-34
5.18.3	Electronics Units.....	5-35
5.19	DELIVERABLE ITEMS	5-36
5.19.1	Instrument Models.....	5-36
5.19.2	Electrical Ground Support Equipment (EGSE)	5-36
5.19.3	Mechanical Ground Support Equipment (MGSE).....	5-36
5.19.4	Optical Ground Support Equipment (OGSE)	5-37
5.19.5	System Test Software.....	5-37
5.19.6	Hardware for the Observatory Ground Segment	5-37
5.19.7	Software for the Observatory Ground Segment.....	5-37
5.19.8	Instrument Software Simulator	5-37
5.19.9	Test Reference Data.....	5-37
5.19.10	Instrument Characterisation Data.....	5-37
5.19.11	Technical Documentation	5-37

CHANGE RECORD from IIDR

ISSUE	DATE	SECTION	CHANGE(S) MADE
2.0	18/4/01	All	Baseline reviewed at IIDR
2.1	6/6/01	5.19.1	Section had included BSM markups in 2.0 despite being labelled "Not updated". Tidied up.
		Figure 5.2.1	Insert most up-to-date version
		All	Highlighted in red text needing ESA action, presumably via its agent Alcatel.
		5.3.2.1	Temporarily scored through optical alignment numbers because what is written is incorrect.
		5.7.3	Add E-mailed max rate of change of SVM unit temperatures.
		5.9	Note that ray diagrams are due for update
		5.13.1	Put in latest Harness Layout drawing.
		5.13.2	Add comment about FCU driven subsystems in FPU

APPLICABLE DOCUMENTS

Section to be inserted

REFERENCE DOCUMENTS

Section to be inserted

5 INTERFACE WITH SATELLITE

Spacecraft resource allocations, are based on present knowledge.

5.1 IDENTIFICATION AND LABELLING

Each individual instrument unit is allocated two unique identification codes:

- a *project code* which is the normal reference used for routine identification in correspondence and technical descriptive material.
- a *spacecraft code* finalised by the spacecraft contractor in accordance with the computerised configuration control system to be implemented, and used in particular for connector and harness identification purposes. All of these have now been given a working designation anyway as work has progressed. The *project code* shall form part of the spacecraft code. (See IID-A section 5.1)

The project codes allocated to this instrument are:

Project code	Instrument unit	Location	Temperature
HSDPU	HS Digital Processing Unit	On SVM	Warm
HSFCU	HS FPU Control Unit	On SVM	Warm
HSDCU	HS Detector Control Unit	On SVM	Warm
HSJFS	HS JFETs(Spectrometer)	See section 5.3	Cryogenic
HSJFP	HS JFETs(Photometer)	See section 5.3	Cryogenic
HSFPU	HS Focal Plane Unit	See section 5.3	Cryogenic

in which HS stands for HERSCHEL **Spire**, and may be omitted if the context is unambiguous.

The HSFCU is a physical unit containing two functions, the HSSCU and the HSMCU meaning the HS Sub-System Control Unit and the HS Mechanisms' Control Unit respectively.

[Documentation may refer to a DRCU or Detector Readout and Control Unit. This is no longer a single unit and the term refers collectively to the HSDCU plus the HSFCU.]

There are three groups of harnesses at instrument interface level, HSWxx, HSIxx and HSCxx where xx represents a number. The HSWxx are Warm harnesses between Warm HS units on the SVM. The HSIxx are Intermediate harness external to the cryostat between the 100way vacuum connectors and the HS Warm Units. The HSCxx are cryogenic harness internal to the cryostat between the 100way vacuum connectors and the HS Cryogenic units.

5.2 INTERFACE LOCATIONS

All of the above is best visualised as a block diagram, see figure 5.2.1. The HERSCHEL to HERSCHEL-**Spire** electrical interfaces are in several "planes" shown by dashed blue lines, the categories between each line being labelled along the top.

Note that, to be precise, these electrical interfaces are at the connector planes.

HERSCHEL-SPIRE(HS)

HERSCHEL

HERSCHEL-SPIRE(HS)

HERSCHEL

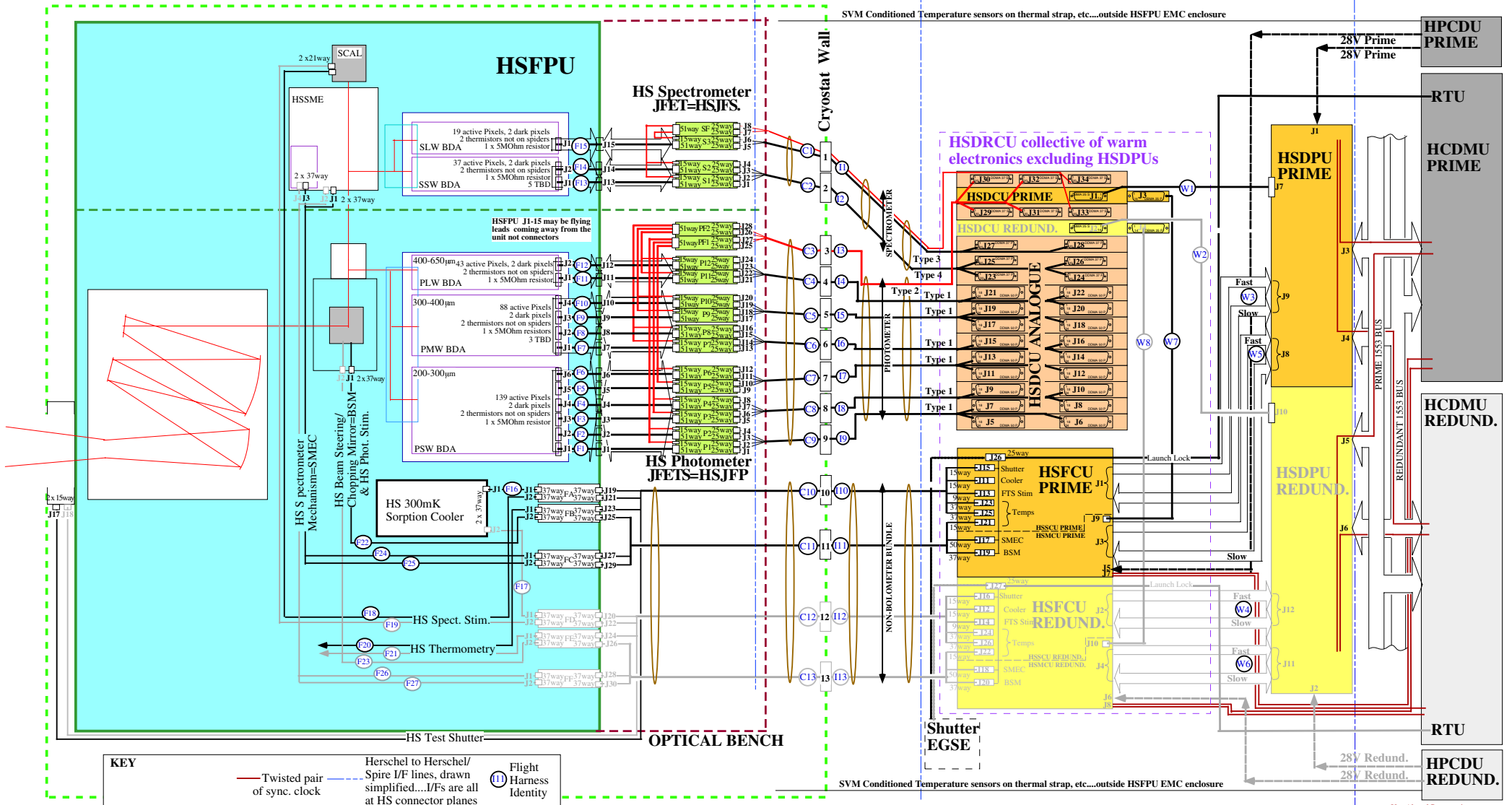

Spire Block Diagram Figure 5.2.1

5.2.1 MECHANICAL COORDINATE SYSTEM

The unit specific x,y,z origin definitions are shown in the External Configuration Drawings. (see section 5.4)

5.3 LOCATION AND ALIGNMENT

Figures 5.3-1 and 5.3-2 show the concept of the location of the three HERSCHEL Focal Plane Units (FPUs) for HIFI, PACS and **Spire** on the Optical Bench (OB) inside the cryostat. The **Spire** FPU has two closeby JFET racks. **This accommodation may be subject to detailed evolution.**

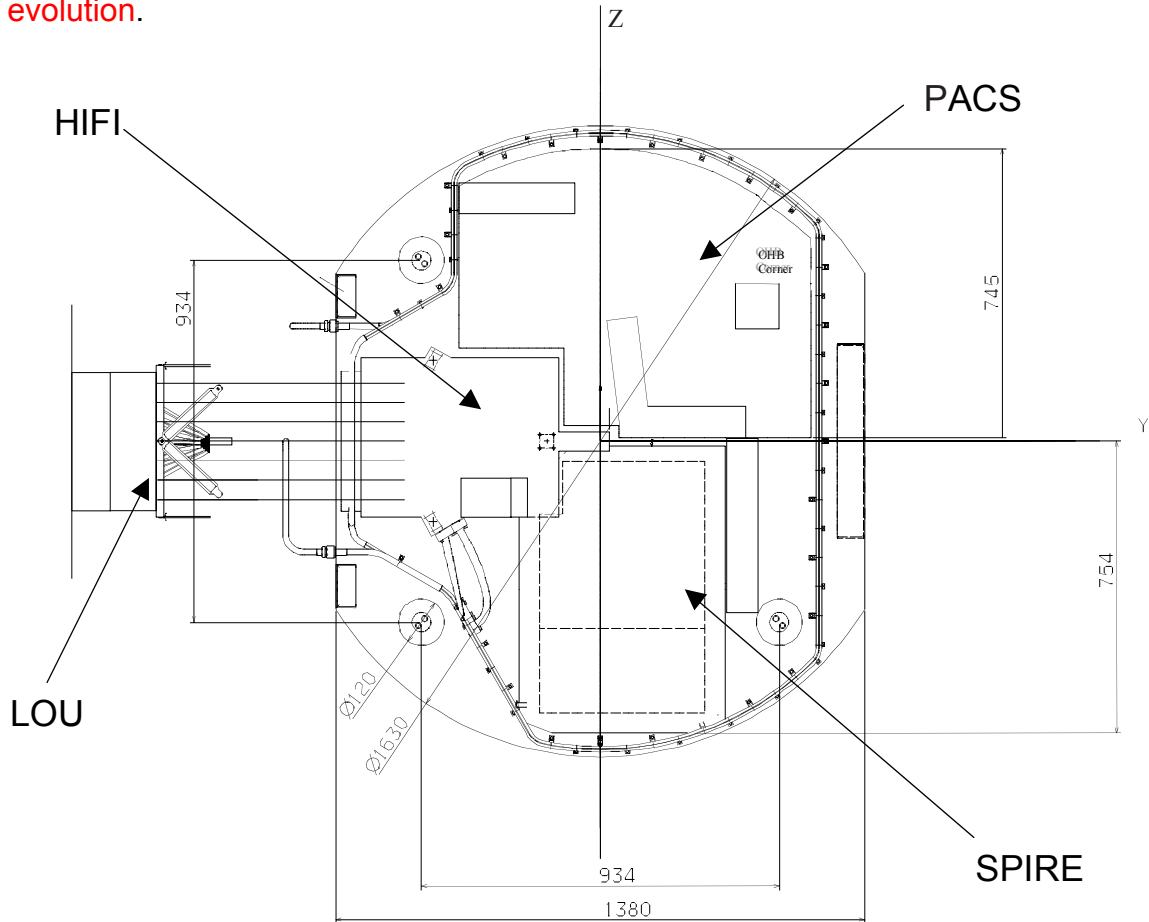

Figure 5.3-1: The HERSCHEL Focal Plane, top view towards -X

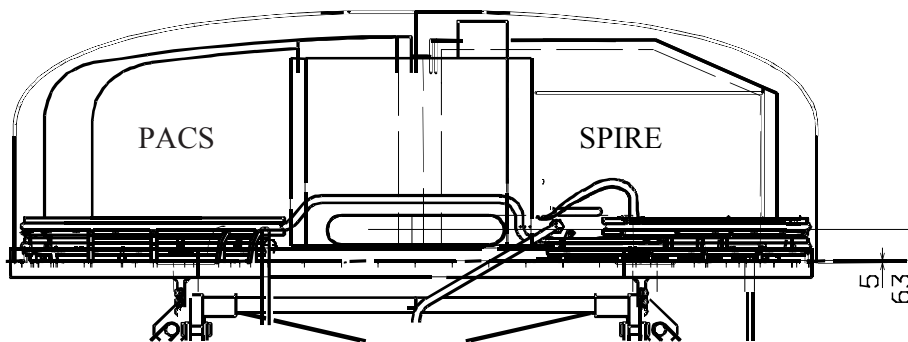

Figure 5.3-2: The HERSCHEL Focal Plane, side view towards +Y

5.3.1 Instrument Location

The locations of the **Spire** units are as listed in section 5.1. **Spire** has no units supported on the outside of the HERSCHEL cryostat or on the Planck Module. There are no critical alignment requirements on the **Spire** JFET boxes.

5.3.1.1 Location of units on the SVM

There are no specific requirements for the location of **Spire** units on the SVM, except that the DRCU needs optimised harness routing towards the **Spire** quadrant of cryostat 100way connectors. **ESA shall advise the Spire Instrument consortium of harness and unit position definitions and 100way type at the earliest date, for comment and for them be recorded herein.**

5.3.2 Instrument Alignment

Spire has no critical alignment and/or alignment stability requirements except for those of the HSFPU. The cryogenic optical position, direction and *tolerance* of the instrument optics' input w.r.t. the instrument's mounting on the Optical Bench is shown on the mechanical interface drawing. The HSFPU has an externally viewable alignment cube, see same drawing. The cube's angular alignment w.r.t. **Spire**'s internal optics will be measured/verified at instrument level before delivery to ESA.

5.3.2.1 Absolute Requirements

Optical alignment must be maintained in 1g vertical for test and in zero g for flight. The absolute alignment requirements of the HSFPU to the Optical Bench at operating conditions are TBC. However **Spire** places the following general requirement on the alignment of the instrument with respect to the HERSCHEL telescope.

Spire is designed such that the instrument's viewed beam is undersized on the feed provided by the HERSCHEL telescope. This prevents the viewing of parts of the telescope structure that would source undesirable stray signal. For instance, the **Spire** optical alignment plan has a nominal size of instrument pupil that should coincide with the HERSCHEL telescope field plane but be linearly under-sized w.r.t. the fully illuminated aperture area ~~by 4.1%.~~ All contributions to this system interface are controlled by an error budget in AD????, ~~but the approach is that components due to factors outside Spire should not account for more than 5% of this 4.1%.~~ For a 308 mm secondary mirror 4.1% is equivalent to a dimension of +/- 3.9 mm. ~~Since Spire will be aligned internally to essentially same limit, HERSCHEL and Spire contributions are equally demanding and at least 91.8% of the 4.1% margin will be maintained.~~

The HERSCHEL telescope alignment plan (AD????) calls for each of the instruments to be integrated to the HERSCHEL optical bench with respect to references thereon and to require no optically driven adjustment thereafter.

5.3.2.2 Stability Requirements

The alignment stability requirements at operating conditions are an essential element of the budget mentioned in section 5.3.2.1., but the values for the changes in alignment that the budget has to accommodate are TBD.

5.4 EXTERNAL CONFIGURATION DRAWINGS

These are included for information only. They are all controlled **Spire** drawings at their latest issue.

5.4.1 FSFPU

Figure 5.4-1 shows drawings for the HSFPU and HSJFS/JFP inside the cryostat and their relationship to the HERSCHEL focal plane, to the cryostat radiation shield and to the diameter of the OB.

The location of both of the JFET racks will need to be optimised to provide short cable lengths to the detectors in the FPU (the reason for their existence) and good routing from their opposite faces for the cryoharness feeds.

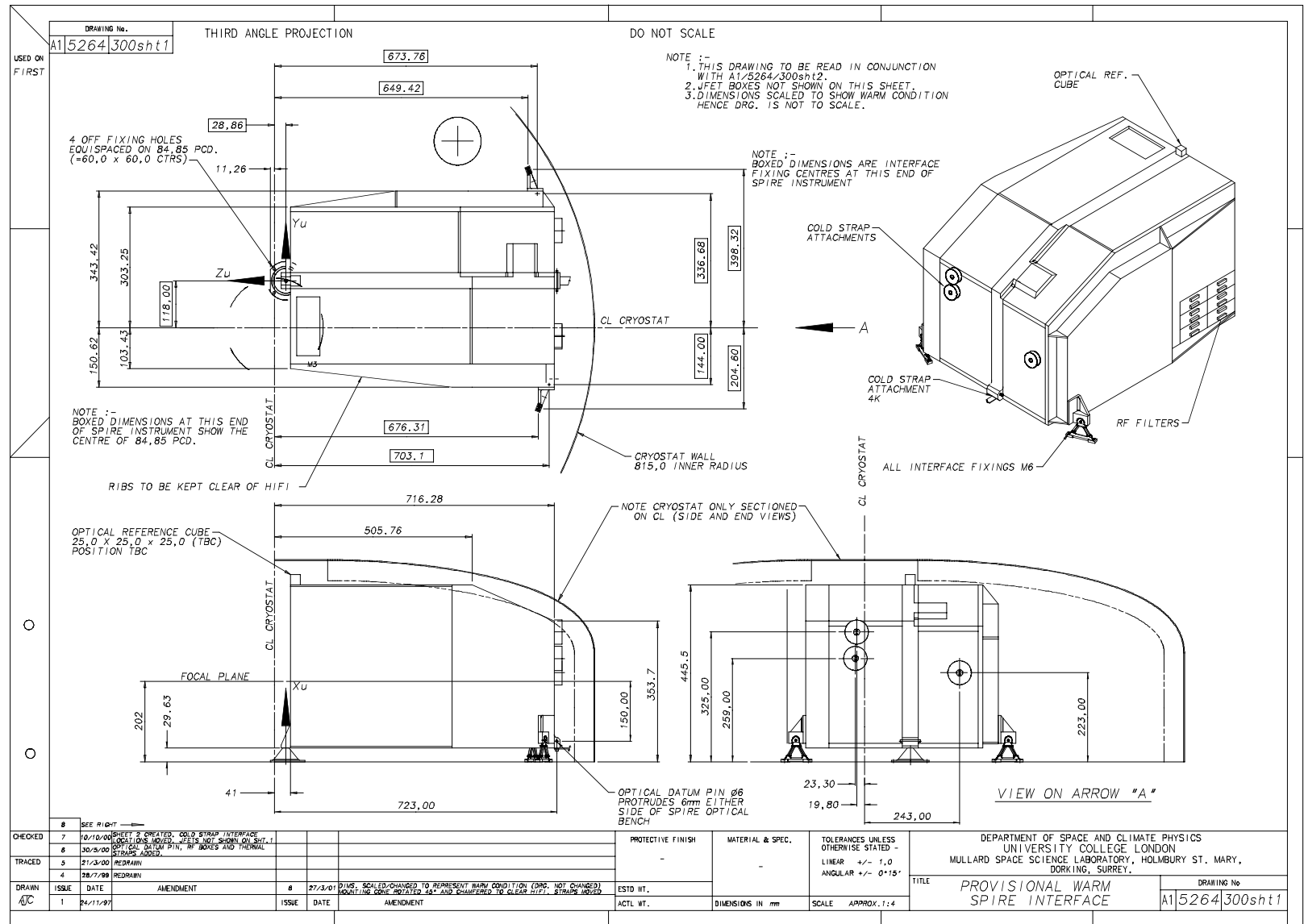

Figure 5.4-1a: **Spire** Focal Plane Unit.....sheet 1

Spire cold harness routing to be added.

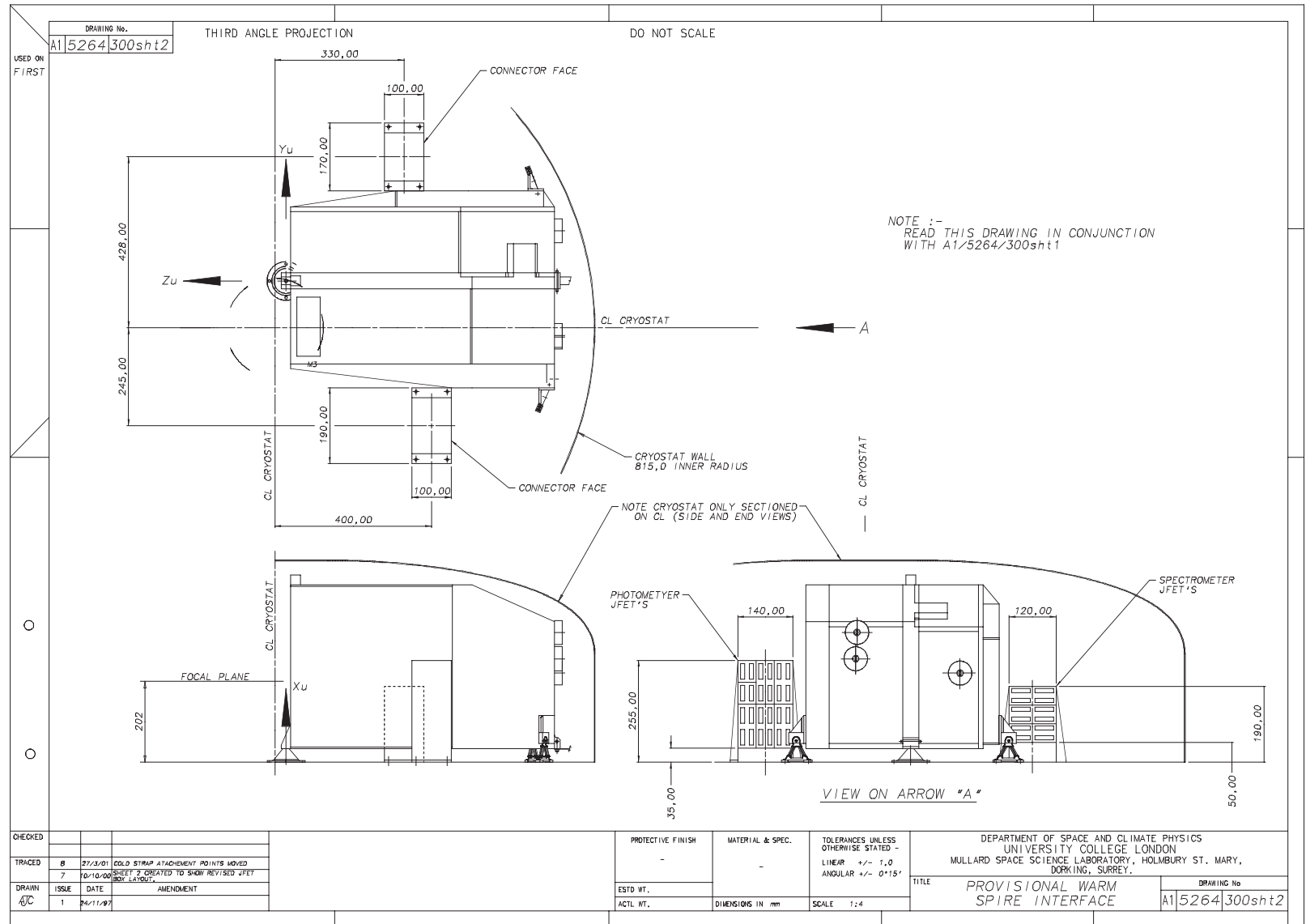

Figure 5.4-1b: **Spire** Focal Plane Unit...sheet 2. The position and size of the JFET boxes is indicative only.

5.4.2 HSSJF

Figure 5.4-3 shows the external configuration drawing for the **Spire** Spectrometer JFET rack (TBW).

5.4.3 HSPJF

Figure 5.4-4 shows the external configuration drawing for the **Spire** Photometer JFET rack (TBW).

5.4.4 SVM Mounted Units.

Figure 5.4-2 shows the **Spire** SVM mounted units and the **Spire** Warm harness' routing.

5.4.4.1 HSDPU

Figure 5.4-5 shows the external configuration drawing for the **Spire** Digital Processing Unit (TBW).

5.4.4.2 HSDCU

Figure 5.4-6 shows the external configuration drawing for the **Spire** Detector Control Unit (TBW).

5.4.4.3 HSFCU

Figure 5.4-7 shows the external configuration drawing for the **Spire** FPU Control UNIT (TBW).

5.5 SIZES AND MASS PROPERTIES

Sizes are given in section 5.4. There follows a mass summary in grams extracted from the definitive **Spire** Budgets' Document, Adxxxx.

5.5.1 Mass on HERSCHEL Optical bench

Item	Estimate	Allocation	Contingency %	All.+Cont
Photometer				
Mirrors	1019	1020	10	1122
Mirrors	348	350	10	385
Filters	8	10	10	11
Filters	539	540	20	648
Detectors	1680	1500	20	1800
Thermal Straps	0	0	0	0
Thermal Straps	282	285	20	342
Cooler	1400	1400	10	1540
Cooler Straps	235	235	20	282
Baffles	2420	2420	20	2904
Baffles	0	0	0	0
Calibration Source	30	30	20	36
Detector Harness	1275	1300	0	1300
BSM (& support)	1100	1100	20	1320
Shutter	200	200	20	240
Non- bolometer RF Filters & Box	1720	1720	0	1720
Cover	7640	7650	15	8797.5
Detector Box	1840	1850	15	2127.5
Mounts,clamps	1310	1310	15	1506.5
TOTAL	23046	22920		26082
Spectrometer				
Mirrors	1312	1320	10	1452
Filters	65	65	10	71.5
Filters	2	2	10	2.2
Detectors	897	1000	20	1200
Baffles	0	0	0	0
Harness	200	200	0	200
Mechanism	1100	1100	20	1320
SME Cp	200	200	20	240
Cover	6880	6880	15	7912
Detector box	1350	1350	15	1552.5
Mounts,clamps	860	860	15	989
Calibration Source	200	200	20	240
TOTAL	13066	13177		15179
Common Structure				
Optical Bench	8000	9000	15	10350
Mounting	540	540	15	621
Cooler I/F	100	100	20	120
Strap Baffles	500	500	20	600
TOTAL	9140	10140		11691
TOTAL FPU	45252	46237		52952

JFET Boxes				
JFET Modules	5490	5500	10	6050
JFET Rack Structure	1500	1500	20	1800
JFET - FPU Interface	300	300	20	360
Back Harness???				
TOTALJFETS	7290	7300		8210

5.5.2 Mass on Service Module

Item	Estimate	Allocation	Contingency %	All.+Cont
HSDPU	6621	7000	20	8400
HSFCU+HSDCU	23000	23000	20	27600
HSW1-8	2000	2000	20	2400
TOTAL	31621	32000		38400

5.5.3 Moments of Inertia and C. of Gs.

The positions of C. of Gs. are shown on drawings in section 5.4.

The x,y,z principle moments about these are as follows: TBD.

5.6 MECHANICAL INTERFACES

5.6.1 Inside cryostat

The Focal Plane Unit, the HSFPU, has 3 supporting feet to the Optical Bench. One of these feet coincides with the HSFPU x,y,z reference, as shown in the External Configuration Drawing. The details of this mechanical interface will be such as to allow the unit alignment and alignment-stability requirements to be fulfilled.

The **Spire** JFET racks will also mechanically interface directly to the Optical Bench.

To fulfil **Spire**'s grounding requirements, the HSFPU and both JFET racks need to be electrically isolated from the Optical Bench at their mechanical mounting points. The same applies to the bolometer system harness screens.

5.6.1.1 Microvibration

Spire's mechanisms, the SMEC and the BSM, are sensitive to μ -vibrations. **Spire** will define its maximum permissible input acceleration level and bandwidth at the FPU OB interface, TBD.

It is also expected **Spire** that will be subject to a restriction on the forces that it can output at this interface, TBC.

5.6.1.2 Thermal Straps

The mechanical I/F geometry, fixing torque, etc. for each of these straps is as baselined in the IIDA. See section 5.4 for positions on **Spire** and section 5.8 for more details.

5.6.2 Outside Cryostat

NA

5.6.3 On SVM

The three units mounted on the SVM will each have 6 attachment points for fixation to the equipment platform, as shown in their External Configuration Drawings. Interface flatnesses, fasteners and tightening torques are all defined on these drawings.

The **Spire** warm harness will attach to the SVM via TBD ESA provided holddown ties.

5.6.4 On Planck Payload Module

NA

5.6.5 Cooler valves and piping

NA

5.7 THERMAL INTERFACES

The cryogenic interfaces are the most important category of interfaces for **Spire**'s success, and the most complicated. They would provide the most gain to science performance from being somewhat improved.

5.7.1 Inside cryostat

The various instrument stages require straps to 3 different temperatures. The cryostat shall provide:

- Level 0: He tank for temperatures at the ~1.7 K
- Level 1: He vent-line at about ~4K
- Level 2: He vent-line at about ~10 K which may be achieved by conduction to the OB.

An overview of this system is:

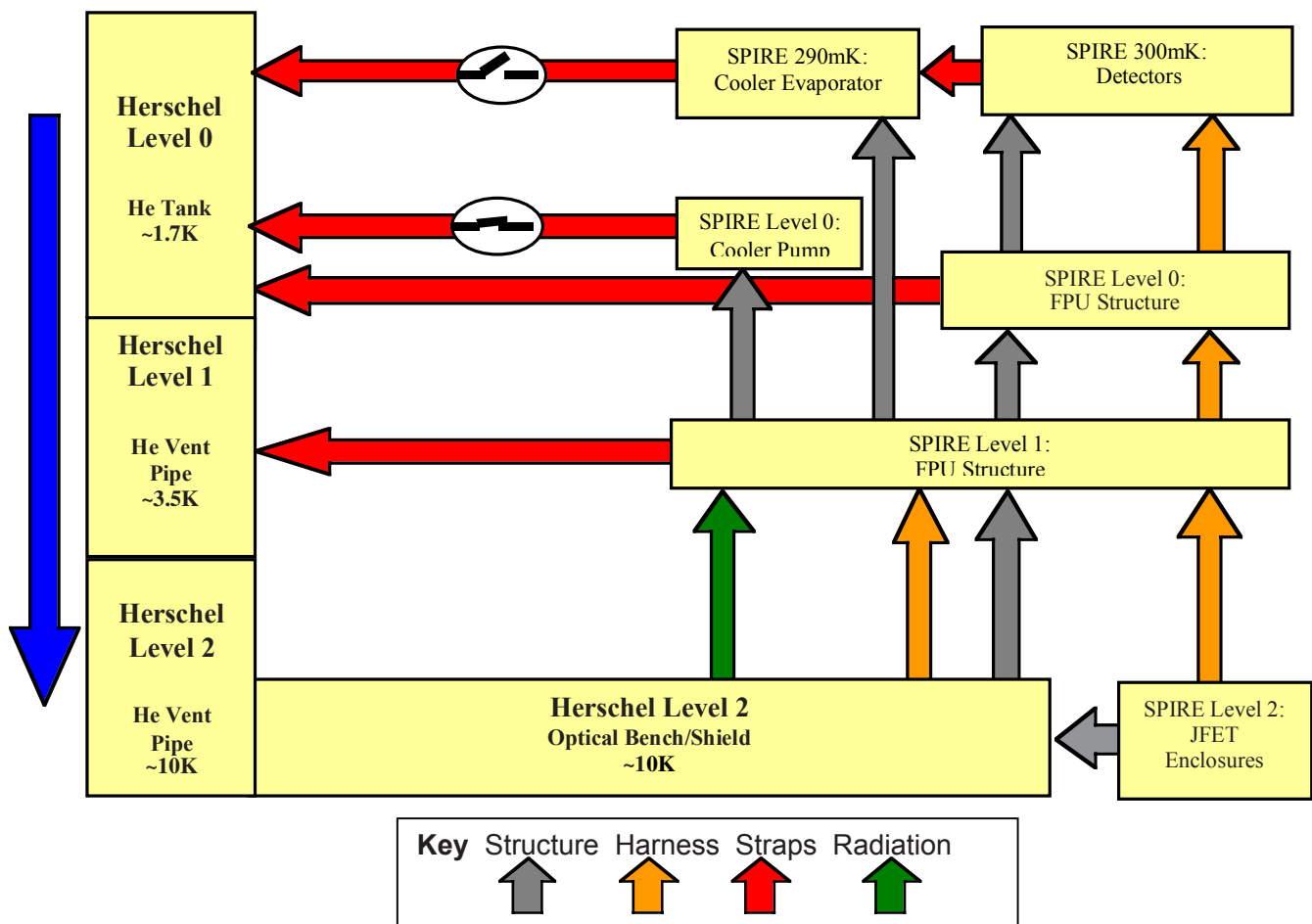

5.7.1.1 Thermal Straps for ³He Cooler

Operation of the **Spire** ³He cooler requires that it is recycled by heating the sorption pump to ~40-K whilst the evaporator is kept at 1.7-K, thus condensing the ³He into the evaporator. The temperature of the evaporator during condensation is critical to the overall efficiency of the cooler.

At the end of the condensation phase the heat switch on the sorption pump is turned ON and the switch on the evaporator is turned OFF. Then there is a substantial peak power from the sorption pump to the cryostat as it re-cools via the strap. This peak power and associated energy will not have any significant impact on the cryostat LHe tank. However it will have a significant temporary impact on the thermal gradient along the strap.

There are two straps from the cooler to separate points on the LHe tank, one for the sorption pump and one for the evaporator. In this way, during normal operation, the temperature of the evaporator strap will remain at $T_{\text{bath}} + \Delta T$ (as small as possible), leading to a good condensation efficiency and less ^3He lost during the cooldown from 1.7 K to 0.3 K. The sorption pump will still operate properly even if the "hot" end of its strap rises momentarily to as much as 10 K.

The **Spire** FPU provides two Level 0 thermal strap interfaces to the ^3He cooler. It also provides a third, separate, Level 0 strap interface for its 1.8K optical box structures which are interconnected internally so as to have just one instrument external I/F.

For ESA cryostat strap mechanical and electrical I/F details see sections 5.7 and 5.14.2.

5.7.1.2 Requirements on Strap I/F temperatures

Spire requires that the following be the worst case thermal I/Fs conditions supplied via the ESA cryostat straps, when sinking the specified thermal loads in section 5.10.1:

Mode	L1 Strap	Enclosures L0 Strap	Evap Strap	Pump Strap
Phot	4.85K	1.785K	1.719K	1.738K
Spec	4.65K	1.776K	1.717K	1.735K
Standby	4.52K	1.771K	1.716K	1.726K
Off	3.63K	1.738K	1.709K	1.715K

We ought to note that instrument performance would benefit if these were improved, but they arise from assuming the HERSCHEL cryostat just meets its ESA supplied TMM under the conditions carefully modelled in the **Spire** Thermal Configuration Control Document, Adxxxx. No HSJFS or HSJFP straps are listed because the present design uses direct mounting conduction to the OB, so they are not fitted, TBC.

5.7.1.3 Worst case temperatures

The cryogenic units must withstand the full thermal environment given in the IIDA, including repeated max. 72hr. 80°C bakeouts and indefinite 60°C soak.

5.7.2 Outside Cryostat

NA

5.7.3 On SVM

The table below shows the required operating temperatures at the interface of the instrument unit with a mounting platform or parts thereof:

Project code	Operating		Start-up °C	Switch-off °C	Non-operating	
	Min. °C	Max. °C			Min. °C	Max. °C
HSDPU	- 15	+ 45	- 30	+ 50	- 35	+ 80
HSFCU	- 15	+ 45	- 30	+ 50	- 35	+ 80
HSDCU	- 15	+ 45	- 30	+ 50	- 35	+ 80

Note:

Acceptance temperature range is from 5⁰ below min. to 5⁰ above max. operating temp.

Qualification temperature range is from 10⁰ below min. to 10⁰ above max. operating temp.

During nominal operation in-flight, the SVM units will not move at more than 3K/hour.

Spire units will use the SVM as a thermal I/F, without formal isolation, to help stabilise the temperature of unpowered sections and absorb dissipated heat when powered by conduction. The units have an anodized aluminium general surface finish. If it is found that other arrangements are needed, such as low temperature limit thermostatted heaters, these shall be external and HERSCHEL furnished. If details are determined on timescales that can be accommodated, **Spire** will build in minimal necessary mounting arrangements for such systems, TBC.

5.7.4 On Planck Payload Module

NA

5.8 TEMPERATURE CHANNELS

5.8.1.1 Instrument Temperature Sensors

The table below shows the measurement of instrument temperatures. These data are available in DPU packets (unless otherwise indicated) via whichever is powered of the prime and redundant sides of the **Spire** electronics. Each side uses different, electrically isolated sensors and will therefore have subtly differing electrical to temperature calibrations..

Location IN HSFPU	Acronym	Sensor Type	Temp. Range	Temp Acc.	Temp Resol.	TM ref.
200-300 μ m PSW BDA	T_PSW_1	Unwebbed bolometer	0.2 K>5 K	TBD	TBD	TBD
200-300 μ m PSW BDA	T_PSW_2	Unwebbed bolometer	0.2 K>5 K	TBD	TBD	TBD
300-400 μ m PMW BDA	T_PMW_1	Unwebbed bolometer	0.2 K>5 K	TBD	TBD	TBD
300-400 μ m PMW BDA	T_PMW_2	Unwebbed bolometer	0.2 K>5 K	TBD	TBD	TBD
400-650 μ m PLW BDA	T_PLW_1	Unwebbed bolometer	0.2 K>5 K	TBD	TBD	TBD
400-650 μ m PLW BDA	T_PLW_2	Unwebbed bolometer	0.2 K>5 K	TBD	TBD	TBD
SSW BDA	T_SSW_1	Unwebbed bolometer	0.2 K>5 K	TBD	TBD	TBD
SSW BDA	T_SSW_2	Unwebbed bolometer	0.2 K>5 K	TBD	TBD	TBD
SLW BDA	T_SLW_1	Unwebbed bolometer	0.2 K>5 K	TBD	TBD	TBD
SLW BDA	T_SLW_2	Unwebbed bolometer	0.2 K>5 K	TBD	TBD	TBD
JFET temps (15off)	TBD	TBD	TBD	TBD	TBD	TBD
Spect JFET chassis	TBD	CX-1070	TBD	TBD	TBD	TBD
Phot JFET chassis.	TBD	CX-1070	TBD	TBD	TBD	TBD
FSFPU chassis.	TBD	CX-1070	TBD	TBD	TBD	TBD
Photometer 2K box	TBD	CX-1050	TBD	TBD	TBD	TBD
Spectrometer 2K box	TBD	CX-1050	TBD	TBD	TBD	TBD
M3,5,7 Optical Subench	TBD	CX-1050	TBD	TBD	TBD	TBD
FTS BB thermA	TBD	CX-1050	TBD	TBD	TBD	TBD
FTS BB thermB	TBD	CX-1050	TBD	TBD	TBD	TBD
Pump	TBD	CX-1050	TBD	TBD	TBD	TBD
Evap.	TBD	CX-1030	TBD	TBD	TBD	TBD
Shunt.	TBD	CX-1030	TBD	TBD	TBD	TBD
Pump heat SW	TBD	CX-1050	TBD	TBD	TBD	TBD
Evap. heat SW.	TBD	CX-1050	TBD	TBD	TBD	TBD
Phot BB thermA	TBD	CX-1050	TBD	TBD	TBD	TBD
Phot BB thermB	TBD	CX-1050	TBD	TBD	TBD	TBD
BSM/SOB I/F	TBD	CX-1070	TBD	TBD	TBD	TBD
SMEC Mechanism	TBD	CX-1050	TBD	TBD	TBD	TBD
BSM	TBD	CX-1050	TBD	TBD	TBD	TBD
Shutter Vane therm A *	TBD	CX-1070	TBD	TBD	TBD	TBD
Shutter Vane therm B *	TBD	CX-1070	TBD	TBD	TBD	TBD
Shutter Actuator *	TBD	CX-1070	TBD	TBD	TBD	TBD
Input Baffle	TBD	CX-1050	TBD	TBD	TBD	TBD

*Handled by EGSE, not FCU/DPU

5.8.1.2 Satellite Temperature sensors

In addition to the **Spire** conditioned temperature channels, **Spire** requires that HERSCHEL itself shall monitor the temperatures of certain locations on the cryostat and SVM. These are given in the table below.

Location	Sensor Type	Temp. Range	Temp Accuracy	Temp. Resol.	TM ref.
Level 0 Strap A to cooler	ESA TBD	1.5K to 90°C	TBD	TBD	TBD
Level 0 Strap B to cooler	ESA TBD	1.5K to 90°C	TBD	TBD	TBD
Level 0 Strap to HFSFPU 1.8k boxes	ESA TBD	1.5K to 90°C	TBD	TBD	TBD
Level 1 strap to HSFPU	ESA TBD	1.5K to 90°C	TBD	TBD	TBD
Level 2 strap to HSJFS	ESA TBD	1.5K to 90°C	TBD	TBD	TBD
Level 2 strap to HSJFP	ESA TBD	1.5K to 90°C	TBD	TBD	TBD
Optical bench at HSFPU the three mechanical interfaces	ESA TBD	1.5K to 90°C	TBD	TBD	TBD
SVM at HSDPU mechanical interface	ESA TBD	-80 to 90°C	TBD	TBD	TBD
SVM at HSFCU mechanical interface	ESA TBD	-80 to 90°C	TBD	TBD	TBD
SVM at HSDCU mechanical interface	ESA TBD	-80 to 90°C	TBD	TBD	TBD

5.9 OPTICAL INTERFACES

Spire's only optical interface is that toleranced in section 5.3.2. The instrument's optical design is now frozen and well analysed, see AD xxxx.

For information, figures 5.8-1, 5.8-2, 5.8-3, 5.8-4 and 5.8-5 show the **Spire** optical beam envelope at various places through the path from the telescope focal plane to the hole in the HERSCHEL primary mirror. No structure or other material is allowed within the envelope defined by these "footprints". A definitive full analysis taking diffraction into account is given in AD????

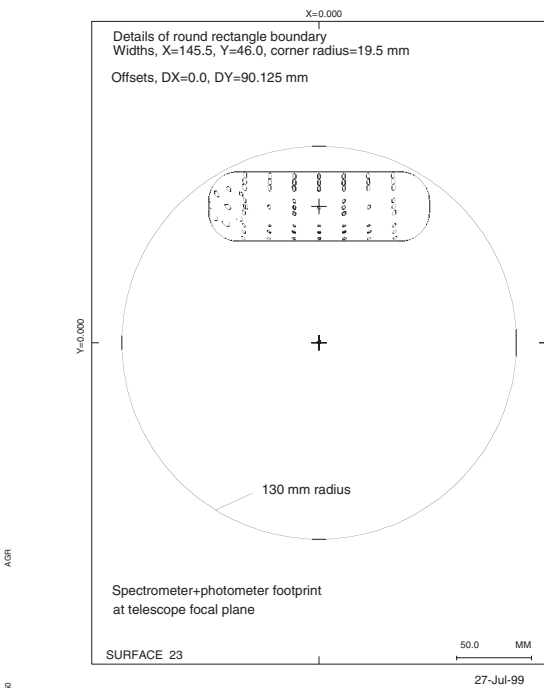

Reversed PHOT126B + SP460C

Figure 5.8-1 **Spire** optical beam envelope at the telescope focal plane.

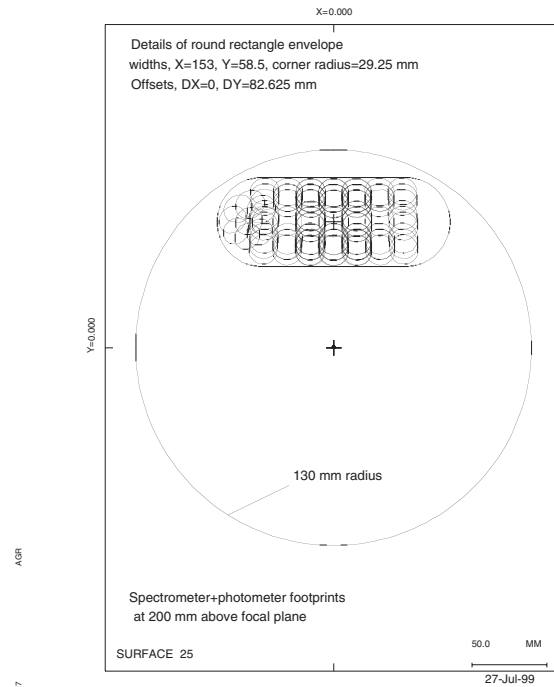

Reversed PHOT126B + SP460C

Figure 5.8-3 **Spire** optical beam envelope at 200 mm above telescope focal plane.

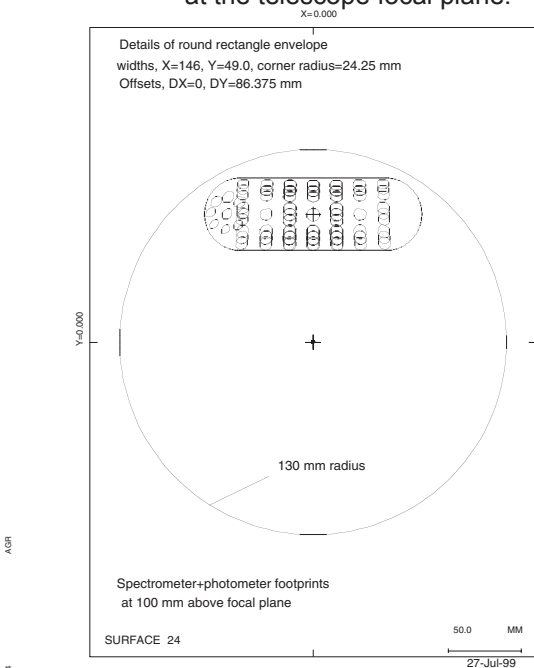

Reversed PHOT126B + SP460C

Figure 5.8-2 **Spire** optical beam envelope at 100 mm above telescope focal plane.

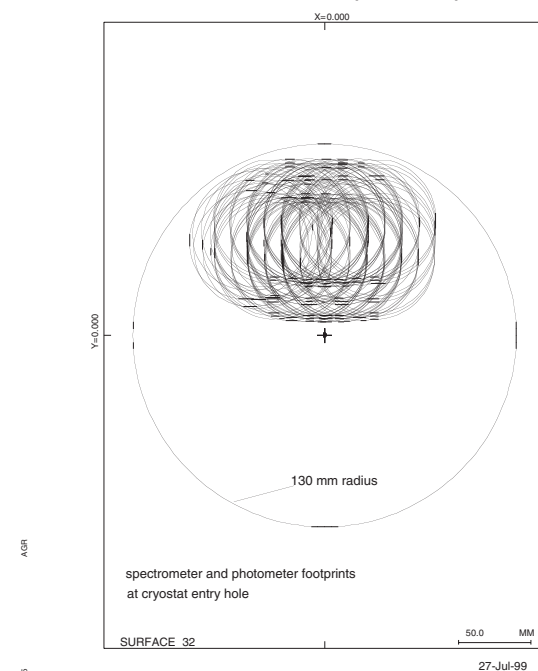

Reversed PHOT126B + SP460C

Figure 5.8-4 **Spire** optical beam envelope at the exit hole from the HERSCHEL cryostat.

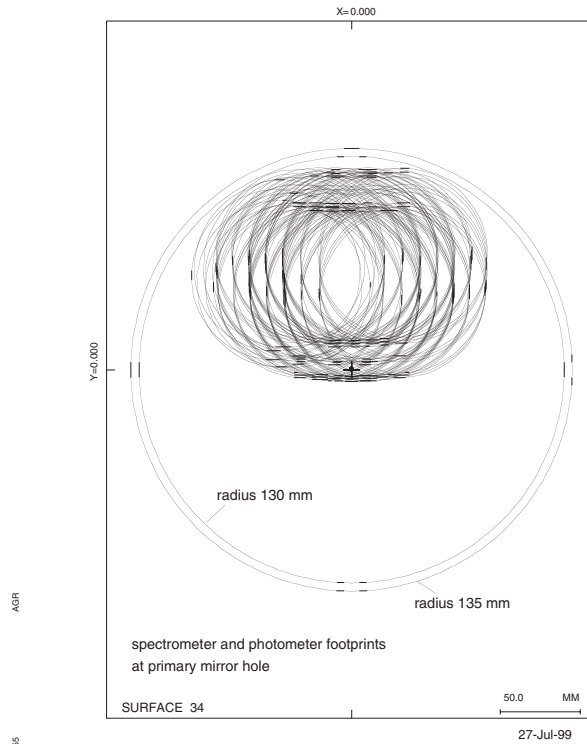

Figure 5.8-5 **Spire** optical beam envelope at the hole in the HERSCHEL telescope primary mirror

Note that the spectrometer's used beam lies next to that of the photometer although more off-axis, and that optically both are illuminated simultaneously although they then view different places on the sky; beam switching is not used.

The above diagrams will shortly be updated, but the implications are already accounted for.

5.9.1 Straylight

The instrument straylight model and its conclusions for alignment etc. are described in RDxxxx.

5.10 POWER

5.10.1 Inside cryostat

The whole situation is specified in great detail in the Thermal Configuration Control Document, Adxxxx.. The following table is for the same configuration as the case applicable to the strap I/F temperatures specified in section 5.1.1.1.

PARAMETER	Heat Load Estimate (mW)			
	PHOT	SPEC	STNDBY	OFF
Level 2 Summary				
HEAT LOAD ON SPIRE L2:	49.5	14.1	49.5	0.0
ESTIMATED HEAT LEAK FROM SPIRE L2 TO L1:	12.58	7.46	12.88	6.25
ESTIMATED HEAT LOAD ON HERSCHEL L2:	36.95	6.66	36.65	-6.24
IID-A MAXIMUM AVERAGE HEAT LOAD BUDGET TO HERSCHEL L2:	50	50	50	50
Level 1 Summary				
ESTIMATED HEAT LOAD ON SPIRE L1:	16.68	15.86	12.89	6.25
ESTIMATED HEAT LEAK FROM SPIRE L1 TO L0:	4.22	3.79	3.51	1.92
ESTIMATED HEAT LOAD ON HERSCHEL L1 STRAP:	12.46	12.07	9.37	4.34
IID-A MAXIMUM AVERAGE HEAT LOAD BUDGET TO HERSCHEL L1:	25	25	25	25
L0 Summary				
ESTIMATED HEAT LOAD ON SPIRE L0:	4.419	3.993	3.513	1.923
ESTIMATED HEAT LEAK FROM SPIRE L0 TO 300mK STAGE:	0.024	0.024	0	0
ESTIMATED HEAT LOAD ON HERSCHEL L0 STRAPS:	4.405	3.980	3.524	1.928
IID-A MAXIMUM AVERAGE HEAT LOAD BUDGET TO HERSCHEL L0:	10	10	10	10

Excludes conducted and dissipative heatloads from cryo harness connecting to 300 K level.

Includes dissipation of ³He refrigerator when operating (Averaging the load during operation and recycling – recycle mode dissipates 90 mW (TBC) for 2 out of every 48 hours). The parasitic loads from 4 to 2 K through the structure and heat switches amount to 1 mW (TBC).

5.10.2 Outside Cryostat

NA

5.10.3 On SVM

The table shows the heat dissipation of the units mounted on the SVM in Watts:

Unit	Estimate	Allocation	Contingency %	All. + Cont.
HSDPU	24	15	20	18
HSFCU+HSDCU	67	71	20	85.2
HSWIR	<0.1	0	0	0
TOTAL		86		103.2

These apply to all modes, and the S/C shall only empower either prime or redundant throughout **Spire**.

5.10.4 On Planck Payload Module

NA

5.10.5 Power versus Instrument Operating Modes

The table below shows the status of the instrument subsystems in the various instrument modes.

Unit	Subsystem	Recycle	Off	On	Standby/ Parallel/ Serendipity	Observe	
						PHOT	SPEC
HSFPU	Detector Bias	OFF	OFF	OFF	ON	ON	ON
	Photometer Cal Source	OFF	OFF	OFF	OFF	X	OFF
	Spect Cal Source	OFF	OFF	OFF	OFF	OFF	ON
	Cooler	ON	OFF	OFF	ON	ON	ON
	BSM	OFF	OFF	OFF	ON	ON	ON
	FTS Mechanism	OFF	OFF	OFF	OFF	OFF	ON
HSFTB	JFET amplifiers	ON	OFF	OFF	ON	ON	ON
HSFCU + HSDCU	Read-out electronics & Mechanism drive Electronics	ON	OFF	OFF	ON	ON	ON
FSDPU	Digital Processing Unit	ON	OFF	ON	ON	ON	ON

ON =	Operational;
OFF =	Inactive;
X =	Either ON or OFF depending on instrument configuration.

5.11 POWER BUS INTERFACES.

5.11.1 28 Volt main-bus

5.11.1.1 Load on main-bus

The total power load **Spire** places on the 28V main-bus is defined In the **Spire** Budgets' Document. The following is an extracted summary:

Operating mode	Average BOL (beginning of life) (W)	Average EOL (end of life) (W)	Peak (W)
Observe	86 W	TBD	TBD
Parallel	86 W	TBD	TBD
Serendipity	86 W	TBD	TBD
Standby	86 W	TBD	TBD
Cooler Recycle	86 W	TBD	TBD
On	15 W	TBD	TBD
Off	0	0	0

5.11.1.2 Interface circuits

The HSDPU and the HSFCU both receive prime and redundant 28V feeds. Their power interfaces circuit are TBD.

Connectors used are DPU J1-2 and FCU J5-6.

5.11.1.2.1 HSDPU Power Input Circuit Configuration

5.11.1.2.2 HSFCU Power Input Circuit Configuration

5.11.2 Keep Alive Line (KAL)

Because **Spire** will not be switched-on/off frequently, the implementation of a KAL is not envisaged. For details of switch down actions see the IIDB operating modes section.

5.12 ELECTRICAL SIGNAL INTERFACES

5.12.1 1553 Data Buses

The 4 interfaces to the two (prime and redundant) buses between the **Spire** instrument DPUs and the CDMS shall conform to MIL-STD-1553B, with the CDMS controlling the bus.

The 4 **Spire** interfaces shall have unique bus addresses, consistent with HERSCHEL properly controlling the use of Prime and Redundant equipments.

A long stub configuration shall be used for each of the 4 interfaces.

Connector use is as follows:

DPU Connector	Prime Bus	Redundant Bus
Prime DPU	J3	J4
Redundant DPU	J5	J6

5.12.2

5.12.3 Synchronisation

HERSCHEL shall supply 8 isolated transformer coupled 2¹⁷Hz. synchronisation signals. These are shown as brown lines in figure 5.2.1. They are therefore supplied unground-referenced. They should all be themselves in sync. to better than 0.2µsec.

At least one to each of the powered **Spire** DPU & FCU units shall be active before and while the said unit is powered.

Spire will not join any of these signals together Ohmically. It will low pass filter these signals after combining and before squaring them, so HERSCHEL can leave any combination between the required 2 and all 8 active at any one time.

Electrical interface details TBD, although connectors are DPU J3-6 and FCU J7-8.

5.12.4 Launch confirmation

Spire has three cryogenic mechanisms: BSM; SMEC; shutter. It is baselined that each will need to be launch-locked and will feed isolated micro-switch contacts to HERSCHEL to confirm this, linking to the HCDMU's RTU inputs..

There will thus be six pairs of these contacts, 3 mechanisms X [wired via prime harness and wired via redundant cryoharness].

HERSCHEL should check each of their states using <10V and <2mA as part of the early launch procedures.

Connectors used are FCU J26 -27.

5.13 CONNECTORS, HARNESS, GROUNDING, BONDING

5.13.1 Harness and Connectors

Spire harnesses are shall be as defined in Adxxxx, which needs to have harness length incorporated as soon as details are agreed. For information, the following configuration is extracted from the document.

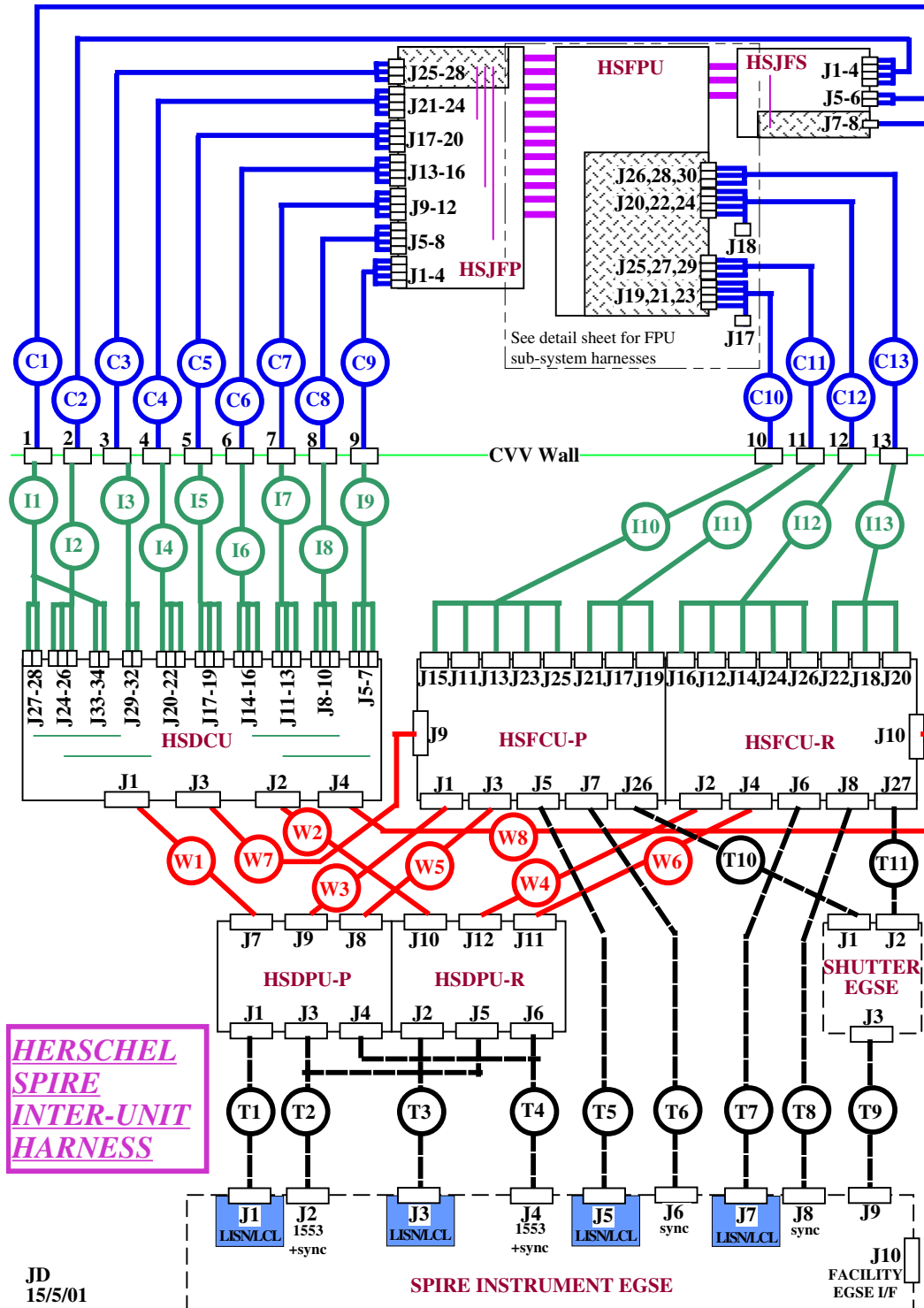

Note that the Cryo-harness, i.e.series C and I, are ESA provided and not **Spire** flight H/W, whilst the T series apply only for instrument test and are not **Spire** flight items.

5.13.2 Grounding

The **Spire** grounding scheme is worked through in ADxxxx. This will be essential to the satisfactory performance of the instrument, it being vital that interfaces do not cause energy to be dissipated in the 300mK section and particularly not in the bolometers themselves.

For information, the following configuration is extracted from the above-mentioned document.

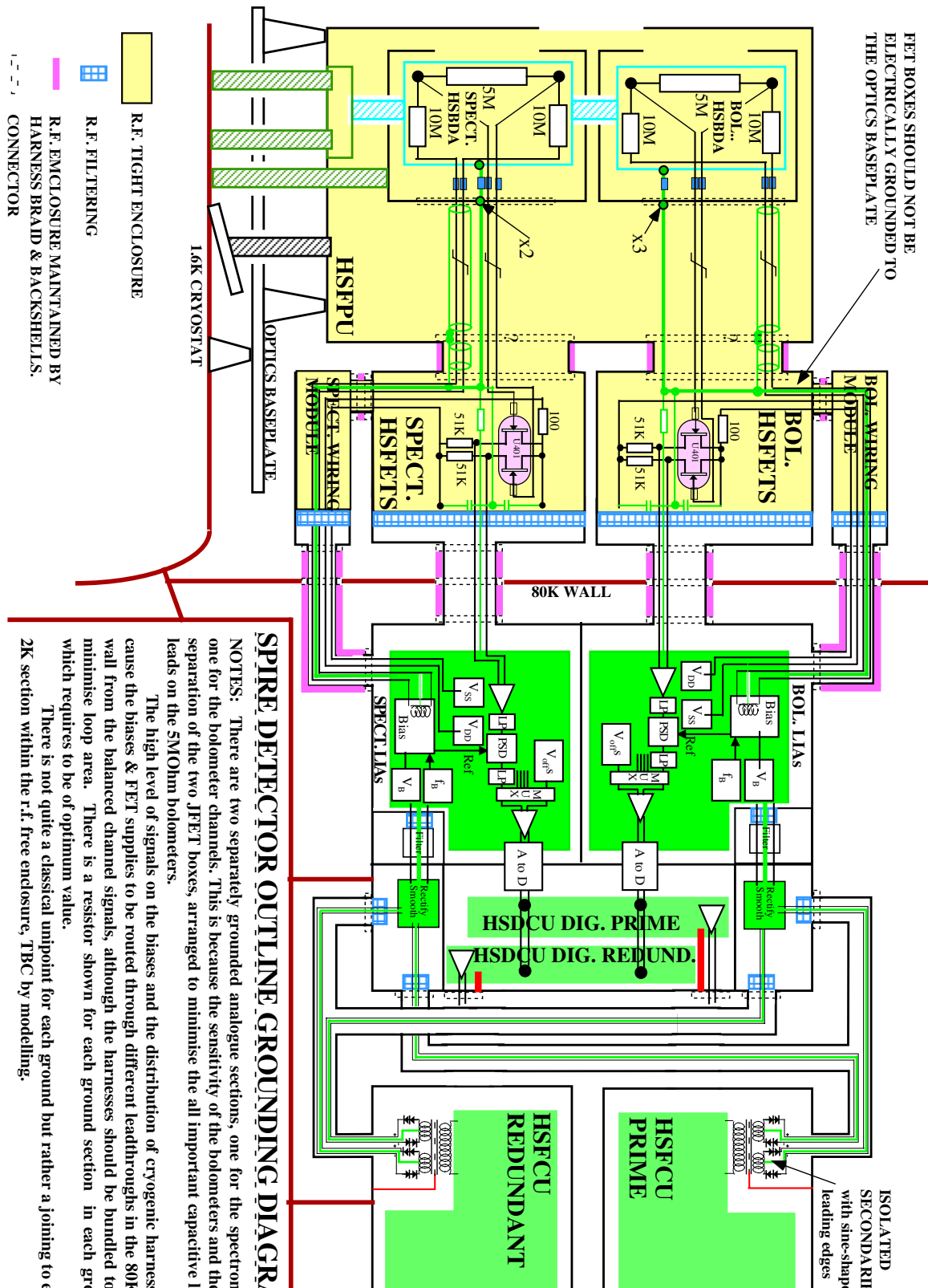

The **Spire** DPU is a "standard" ESA-type secondary power system, whereas the DRCU and FPU shown above are an optimised system w.r.t. minimising the overall bolometer analogue ground noise. The FCU powers the DCU, keeping it free of conditioning noise. The FCU driven items in the FPU, see figure 5.2.1., are considered less critical and will all be Ohmically grounded in the FPU.

Ohmic isolation is baselined within all straps to the cryostat, $>5\text{M}\Omega$ and $<50\text{pF}$ at the working temperature. Note that this isolation is within the strap system, that is a HERSCHEL not a **Spire** element, would seemingly be common to all straps, and of the proven qualified ISO design.

5.13.3 Bonding

It is understood that HERSCHEL bonding applies to harness shields used to maintain closed Faraday cages. Bonded interfaces shall not be used as routine current return paths.

We note that presently all units rely in conductivity via their mechanical mounting feet to S/C. **Spire** would much prefer a formal S/C aluminium strap bounding tree, with controlled straps to all equipments.

5.14 DATA HANDLING

5.14.1 Telemetry.....not updated.

5.14.1.1 Telemetry rate

The instrument produced “raw” housekeeping and science data rates, given for information purposes, are as follows:

Description	Data rate (Kbps)
Housekeeping data rate (non-prime)	2.1
Housekeeping data rate (prime)	4.2
Science data rate: Photometer only	93.6
Science data rate: Spectrometer only	97.4
Science data rate: Parallel mode	10
Science data rate: Serendipity mode	87

Any increase in telemetry rate would have science benefits, as the detector frame rate could be increased making **Spire** more immune from any systematic 1/f noise.

5.14.1.2 Data-bus rate

For the purpose of possible (short duration) higher instrument data-rates the bus interconnecting the instrument and the Data-handling subsystem shall have the capability of handling a telemetry rate of > 200 kbps. This will allow for the rapid emptying of **Spire** on-board data storage units at the end of each observation, thus keeping overheads due to data transfer to a minimum.

5.14.1.3 Data Packets

The instrument is capable to buffer 10 seconds of data. In order to prevent data overflow in the **Spire** on-board data storage units, the S/C CDMS subsystem shall request packets at intervals of no more than 10 seconds (TBC).

5.14.2 S/C housekeeping

The S/C should be capable of monitoring the following instrument parameters every TBD minutes and provide a data packet with the results.

Voltages to instrument

Currents to instrument

Power status – i.e. which **Spire** units are on i.e. FSDPU and FSDRC.

Requested temperatures in Section 5.7.5.2.

5.14.3 Timing and synchronisation signals

The S/C shall provide **Spire** with a timing synchronisation at least once per 24 hours to allow synchronisation of the **Spire** and spacecraft clocks.

When using the telescope scan mode, the **Spire** instrument will require a “start of scan” indication to be sent be included in the telemetry with a timing precision of better than 5 milliseconds. This is required so that the **Spire** data can be correctly processed; it is not required for the operation of the **Spire** instrument.

The **Spire** instrument typically works by its DPU unpacking S/C commands to a lower level, and sending those lower level commands to the DCU and FCU with timings that they can guarantee to keep up with. There is a minimum of handshaking on internal interfaces and, for instance, the DPU has to be ready to receive science data packets from the DPU and FCU whenever they reasonably send them. In these internal data packet headers are counter values permitting accurate datation of all values back to sequence start pulses sent from the DPU. The scheme can be viewed as:

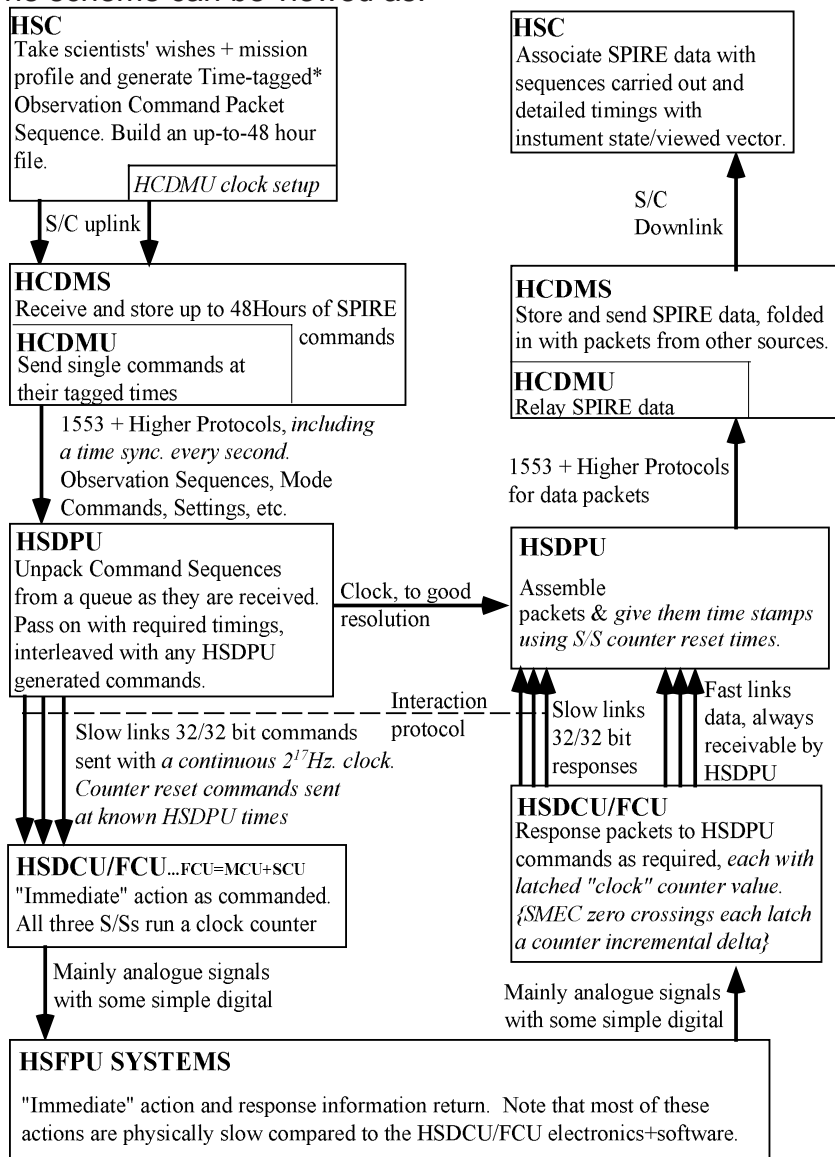

*This process uses known worst case timings for SPIRE operation + margin to ensure that the plan can be implemented and timed starts will not slip.

Note that for the above scheme to work, either the DCU/MCU/SCU need to have no input FIFOs, or the DPU needs to know that they are empty and a reset will go straight through, or these units need to check for the reset pulse in hardware before feeding other packets into a FIFO. TBD.

5.14.4 Telecommand

It is assumed that the observation schedule for each 24 hour period will be uplinked during the data transfer and commanding phase (DTCP). It is further assumed that the correct receipt of all **Spire** commands is verified by the S/C during the DTCP.

The maximum rate of sending command packets from the CDMS to the **Spire** instrument is less than 10 per second.

The maximum telecommand packet length is 256 octets.

All **Spire** telecommands are defined in document Adxxxx.

5.15 ATTITUDE AND ORBIT CONTROL/POINTING

5.15.1 Attitude and orbit control

The **Spire** instrument has the following pointing modes:

- Peak up mode. The ACMS pointing ability quoted in the IID-A (3.7 arcsec APE – see also section 5.12.2) will not be good enough to prevent unacceptable signal loss when observing point sources with the photometer or spectrometer. The **Spire** beam steering mirror will be used to perform a cruciform raster over the observation target and the offset between the required pointing and the actual pointing of the telescope will be provided via an ACMS Data Packet from the **Spire** instrument to the S/C. The S/C will then adjust the pointing accordingly.
- Nodding mode. If the telescope temperature stability time constant proves to be short compared with a typical pointed observation with **Spire**; then the telescope must be capable of being pointed to another fixed position on the sky between 10 arcsec and 4 arcmin from the original pointing in an arbitrary direction with respect to the spacecraft axes. The settling time at each re-pointing must be less than 10 seconds
- Line scan mode. To map large areas of the sky, the telescope must be capable of being scanned up to 20 degrees at a constant rate in an arbitrary orientation with respect to the spacecraft axes. The rate of scan must be variable between 0.1 arcsec/sec and 60 arcsec per second. It is expected that the RPE will be maintained in the orthogonal direction during the scan. The S/C must be capable of reaching any scan speed up to the maximum within 20 seconds of the observation commencing.
- Raster mode. To finely sample the **Spire** FOV the instrument beam steering mirror will be used to step the FOV across the sky in an arbitrary direction. The step size will be between 1.7 arcsec and 30 arcsec. The beam steering mirror can also be used to chop a portion of the **Spire** FOV at a rate up to 2 Hz.

In the event of a failure in this sub-system the S/C will be used in raster mode to sample the FOV. This is acknowledged to be much less efficient than using the internal beam steering mirror. The spacecraft must, nevertheless, be capable of providing a rectangular raster with steps of between 1.7 and 30 arcsec in any arbitrary orientation with respect to the S/C axes.

To map extended regions using the spectrometer, the **Spire** instrument will use the telescope Normal Raster Mode. The instrument may perform fine sampling of each raster pointing using the internal beam steering mirror.

5.15.2 Pointing

The **Spire** instrument requires an absolute pointing error of better than 1.5 arcsec r.m.s. (TBC), and a relative pointing error of better than 0.3 arcsec r.m.s. per minute.

This is achieved by the peak up mode in case the pointing goal values are not fully achieved by the S/C.

5.15.3 On-Target Flag (OTF)

For pointed observations it is assumed that an on target flag will be provided through the telemetry with a timing precision of better than 0.1 seconds (TBC). This is required for the correct processing of the **Spire** data on the ground; it is not required for **Spire** operations. (Note: developed from different view in IID-A)

5.16 ON-BOARD HARDWARE/SOFTWARE AND AUTONOMY FUNCTIONS

5.16.1 On-board hardware

There is a single on-board computer in each of the prime and redundant **Spire** HSDPUs. These have the only non-hardcoded on-board software used in **Spire**.

5.16.2 On-board software

It is assumed that the **Spire** warm electronics will remain powered during all operational phases. The DPU will download baseline software from ROM during power up but some additional software may be required (TBD) to be unlinked before observations commence, either patches or whole modules/objects.

No single instrument command nor any sequence of instrument commands will constitute a hazard for the instrument so the HSDPU is required to trap out any such situations. For the same reason, the HSDPU shall ensure its own correct function, at least as far as checking memory function in the background, checksummed read only areas, and an inhibitible SEU safing capability.

5.16.3 Autonomy functions

The S/C must be capable of automatic monitoring all **Spire** Spacecraft Housekeeping parameters, i.e. the parameters listed in section 5.11.2, when the S/C is not in ground contact.

The S/C must also be capable of monitoring certain **Spire** Instrument Housekeeping parameters provided to it via "Housekeeping Data" packets from the **Spire** DPU – see 5.13.4.

The S/C must be capable of taking predefined action – e.g. switching off the power to the **Spire** instrument – when an error or hard limit is detected in either the **Spire** S/C Housekeeping or the **Spire** Instrument Autonomous Housekeeping parameters.

The S/C must be capable of receiving and interpreting **Spire** "Event Data" packets that will alert the S/C of errors or hard limits detected by the **Spire** DPU autonomy monitoring software. Again the S/C must be capable of taking the appropriate pre-defined action on detecting an error alert in the **Spire** Event Data.

5.16.4 Instrument Autonomy Housekeeping Packet Definition

TBD

5.16.5 Instrument Event Packet Definition

TBD

5.17 EMC

5.17.1 Conducted Emission/Susceptibility

None to be found under required test conditions

5.17.2 Radiated Emission/Susceptibility

None to be found under required test conditions

5.17.3 Frequency Plan

Spire shall have all its internal oscillators for signal/power synchronised to S/C sync. signals.

5.18 TRANSPORT AND HANDLING PROVISIONS

5.18.1 Focal Plane Unit

5.18.1.1 Transport Container

The **Spire** FPU (FSFPU) will be transported in a clean hermetically sealed container to be opened only in class 100 clean conditions (TBC) with less than 50% humidity (TBC).

The maximum shock the FSFPU can sustain in any direction is (TBD). The transport container is fitted with shock recorders and internal humidity monitors. The FSFPU transport container is shown in figure TBD.

5.18.1.2 Cooling and Pumping restrictions

During cryostat warm-up or cool-down phases the rate of temperature change dT/dt shall not exceed 10 K/hour (TBC). The rate of depressurisation/pressurisation dP/dt shall not exceed 50 mBar/minute (TBC).

5.18.1.3 Mechanism positions

For reasons of possible damage caused by vibration during transport, environmental testing and launch, mechanisms shall be placed in the TBD position. This position is shown in table TBD.

5.18.1.4 Unpacking Procedure

The procedure for removing and installing the FSFPU from its transport container is given in document TBW

5.18.2 JFET/Filter Box

5.18.2.1 Transport Container

The **Spire** JFET/Filter Box (FSFTB) will be transported in a clean hermetically sealed container to be opened only in class 100 clean conditions (TBC) with less than 50% humidity (TBC).

The maximum shock the FSFTB can sustain in any direction is (TBD). The transport container is fitted with shock recorders and internal humidity monitors. The FSFTB transport container is shown in figure TBD.

5.18.2.2 Unpacking Procedure

The procedure for removing and installing the FSFTB from its transport container is given in document TBW

5.18.3 Electronics Units

5.18.3.1 Transport Container

The **Spire** warm electronics units (FSDRC; FSDPU; FSWIH) will be transported in clean hermetically sealed containers to be opened only in class 10000 clean conditions (TBC) with less than 75% humidity (TBC).

The maximum shock any of the warm electronics units can sustain in any direction is (TBD).

The transport containers are fitted with shock recorders and internal humidity monitors.

The **Spire** warm electronics transport containers are shown in figure TBD.

5.18.3.2 Unpacking Procedure

The procedures for removing and installing the **Spire** from warm electronics units their transport containers are given in document TBW

5.19 DELIVERABLE ITEMS

5.19.1 Instrument Models.

The model philosophy to be adopted for the AIV of the HERSCHEL **Spire** instrument will be in accordance with the **Spire** Development Plan and Model Philosophy, ADxxxx.

In outline, the instrument models to be produced are:

AVM – The Avionics Model shall permit us “...to validate electronics and software for its interface with the S/C, including anything that exchanges information with, for example, the AOCS. In addition all tasks relevant to **Spire** autonomy shall be verified.” This requires a DPU in at least form, fit and function plus a simulator of the DRCU and cold FPU – collectively termed the DRCU Simulator. As the schedule demands that this model will be delivered almost simultaneously with the CQM, it is planned to use the CQM DPU in the AVM.

CQM - Cryogenic Qualification Model. For both the cold FPU and the warm electronics it is assumed that this is built to flight standards, but not necessarily using flight quality electronic components. The performance capabilities of the instrument may be less than the proto-flight model - i.e. fewer pixels in the focal plane arrays, but it will mimic as exactly as possible the thermal, electrical and mechanical properties of the flight instrument and will be capable of under going the full environmental qualification programme

PFM – Proto-Flight Model. This will be the model that is intended for flight, built to full flight standards. The PFM will therefore undergo environmental test to qualification levels for acceptance times (TBD) - this applies to both the warm electronics boxes and the cold FPU. A CQM qualification review will determine if in fact the PFM has needed sufficient updates that full requalification is needed in some respects.

FS – Flight Spare. The flight spare cold FPU will be made from the refurbished CQM (TBC). The flight spare warm electronics will consist of spare electronics cards/modules/harness.

5.19.2 Electrical Ground Support Equipment (EGSE)

Electrical Ground Support Equipment (EGSE) will be needed to provide **Spire** instrument level monitoring during instrument integration with the S/C and system level testing.

Deliverables:

- FPU electrical simulator, including simulation of the FSFTB, to enable integration of the FSDRC; FSDPU and FSWIH
- TBD EGSE for integration of the FSFPU
- Quick Look Facility to enable testing of the instrument at system level. This will interface to the S/C test environment via FINDAS.

5.19.3 Mechanical Ground Support Equipment (MGSE)

MGSE is required to ensure safe handling of all instrument components during assembly integration and test procedures.

Deliverables:

- Transport containers
- Instrument to cryostat integration jigs/equipment
- Plus TBD

5.19.4 Optical Ground Support Equipment (OGSE)

OGSE is required to carry out alignment procedures with the telescope.

Deliverables:

- Instrument optics primary alignment and alignment verification jigs/equipment
- Plus TBD

5.19.5 System Test Software

Will be based on the Quick Look Facility - computers and software that allow the monitoring in near real time of the instrument housekeeping parameters and instrument data. This is the basic facility to be used for the ICC operations monitoring for the monitoring of the instrument in-orbit. The same facility with enhanced capabilities will be used for the ground tests and in-orbit check out of the instrument.

5.19.6 Hardware for the Observatory Ground Segment

Quick Look Facility for the Mission Operations Centre for instrument in-flight commissioning. This will consist of TBD workstations etc....and must be identical to the system used for instrument system level testing.

5.19.7 Software for the Observatory Ground Segment

The software for the Quick Look Facility will be delivered to the MOC for instrument in-flight commissioning.

Plus TBD.

5.19.8 Instrument Software Simulator

TBD

5.19.9 Test Reference Data

The **Spire** instrument test reference data will be delivered via FINDAS in the TBD form generated during instrument and system level testing.

5.19.10 Instrument Characterisation Data

The **Spire** instrument characterisation data will be delivered via FINDAS in the TBD form generated during instrument and system level testing.

5.19.11 Technical Documentation

The following documents will be delivered:

- Instrument User Manual following the requirements laid down in the OIRD (AD2)
- Instrument database – this will be delivered via FINDAS in the TBD form generated during instrument and system level testing.
- Each instrument model will be delivered with an Acceptance Data Package consisting of TBD....good way to end a document.