



**SPIRE  
HARNESS DEFINITION**

Doc #: SPIRE-RAL-PRJ-000608  
Issue: 0.7  
Date: 19/09/01  
Page 1 of 136

Subject: **HERSCHEL SPIRE HARNESS DEFINITION**

**PREPARED BY:** D.K. GRIFFIN ..... **Date:** .....

**APPROVED BY:** J. DELDERFIELD..... **Date:** .....

**APPROVED BY:** K. KING..... **Date:** .....



# SPIRE HARNESSES DEFINITION

Doc #: SPIRE-RAL-PRJ-000608  
Issue: 0.7  
Date: 19/09/01  
Page 2 of 136

## CHANGE RECORD

ISSUE	DATE	SECTION	CHANGE(S) MADE
Draft 0.1	28/3/01	All	First Issue
Draft 0.2	11/4/01	All	Still getting it together! No unified style for lists yet.
Draft 0.3	10/5/01	Section 3	Update diagrams to fit latest SPIRE block diagram
		W1-6	Clarify screens as per communication 26/4/01, leaving other pins unchanged.
		C&I 1&3	Update Type 2 and Type 3 harnesses to fit 1:1 to membranes' back harness contacts, using 25pin filters.
		C Type1s	Simplify by carrying signal ground on screens.
		I1	Remove nasty 3 row double density 44 way connectors
		All Cs	Put in JFET and FET filter designations
		I1 Type3	Nasty 44pin 3row DCU connectors removed.
		C10-C13	Add tail wiring details. omitting FCU pin details until unit layout confirmed. Changed HSFCU J21 and J22 to 15 way because don't need more pins.
Draft 0.4	10/8/01	Section 3	Update diagrams to fit SPIRE block diagram iss. 2.5. This uses 37way not 25way BDA service filter modules.
		BP & BS	Include JFET unit Back-Harnesses as separate section, in order to control all major Spire harnesses herein. Move overview of them from section 3 into this new one.
		I11&I13	Change HSFCU J21 and J22 back to 25way because do actually need more pins...stimulator heater omitted in iss0.3!
		F1-15	Make clear has plug/socket at HSFPU wall [A & B]
		C1-13	Ensure harness outer shields inside the cryostat include a break and do not unchangeably join the 100way CVV connector bodies to the HSFPU/HSJFP/HSJFS backshells. Linking them is a left-over from when these units and the 300mK plumbing were all fixed grounded to the cryostat. Shields inside the cryostat now come through 100way pins, reducing their availability for use as signal grounds. The harness is now compatible with the Spire grounding scheme in which either the cryogenic or the warm end of the bolometer analogue system can be joined to chassis ground.
		Acronym	List inserted.
		Wiring list	Append as Annex. This will be included in the IID-B but IS NOT a sufficient specification for the C/I harnesses
		C1 and C3	In draft 0.2 fixed on 12ax for C harnesses inside cryostat where practical to minimise heatleak with screened twisted pairs used on I harnesses outside where RF fields may be larger. Switch to screened twisted pairs on bias lines in C1 and C3 to improve screening at JPL's request, but taking this as OK because they are only small proportion of the overall wires.
C1 and C3	JFET membrane heater wires sized same as combined JFET voltage supply wires because power needs to be the same and heaters will now be sized to make their voltages similar		
Draft 0.4 contd.	10/8/01	C1-2 & C4-9	Show 12ax third wires as joined to ground pin at 25way MDMs and not just at the 100way CVV connectors, to reduce ground noise.



# SPIRE HARNESSES DEFINITION

Doc #: SPIRE-RAL-PRJ-000608  
 Issue: 0.7  
 Date: 19/09/01  
 Page 3 of 136

		C1 and I1	Remove 300mK Thermal Control Thermistor a.c. Biasing from Spectrometer side harness.
		I11 & I13	BSM temp. removed from BSM tail listing as is already in temperature sensors' tail
		T Harnesses	Update Harness drawing etc. to remove "sync": from S/C to HSDRCU and to split EGSE units.
		C/I 10 & 12	Remove JFET box thermistors included in error. Affects DCU J23 and J24 + FCU J23 and J24. Permits cleaner shield to 100way pin allocations.
		C/I 10 & 12	Change to updated Spectrometer Calibrator Wiring.
		C3	Alter multiple heater wires to be in same proportions as multiplicity of JFET modules they heat, rather than the reverse! This arrangement is a bit of a left-over from using 12-ax for this harness, and may disappear in the next issue.
0.5	22/8/01	Appendix	Include Channel # cross-reference listing.
		C4	Remove notes on tail connector PCB tracking.
		F1-15	Include pinouts
		C/I 11&13	Adjust launch latch wires as requested.
0.6	15/09/01	C/I 11&13	Update based on SMEC lists "010906.doc"
		Section 3	Update harness layout with new SMEC FCU connectors
		At end	Append grounding diagram as agreed.
		Annex	Put SMEC updates into wiring list.
		C1/3+Annex	Sort out sexes of RF filters so all the same as C11/13
		C/I 11&13	Make BSM latch drive wire resistance same as SMEC's
0.7	19/09/01	All	Get HOB and SOB sorted
			Change Spectrometer Stim temperature to be Flange, not "near SOB"



# SPIRE HARNES DEFINITION

Doc #: SPIRE-RAL-PRJ-000608

Issue: 0.7

Date: 19/09/01

Page 4 of 136

## ACRONYM LIST

Term	Meaning
ADC	Analogue to Digital Converter
AIV	Assembly, Integration and Verification
AME	Absolute Measurement Error
AOCS	Attitude and Orbit Control System
APART	Arizona's Program for the Analysis of Radiation Transfer
APE	Absolute Pointing Error
ASAP	Advanced Systems Analysis Program
AVM	Avionics Model
BDA	Bolometer Detector Array
BFL	Back Focal Length
BRO	Breault Research Organization
BSM	Beam Steering Mirror
CDMS	Command and Data Management System
CDMU	Command and Data Management Unit
CDR	Critical Design Review
CMOS	Complimentary Metal Oxide Silicon
CPU	Central Processing Unit
CVV	Cryostat Vacuum Vessel
DAC	Digital to Analogue Converter
DAQ	Data Acquisition
DCU	Detector Control Unit = HSDCU
DPU	Digital Processing Unit = HSDPU
DSP	Digital Signal Processor
DQE	Detective Quantum Efficiency
EDAC	Error Detection and Correction
EGSE	Electrical Ground Support Equipment
EMC	Electro-magnetic Compatibility
EMI	Electro-magnetic Interference
ESA	European Space Agency
FCU	FCU Control Unit = HSFCU
FIR	Far Infrared
FIRST	Far Infra-Red and Submillimetre Telescope
FOV	Field of View
F-P	Fabry-Perot
FPGA	Field Programmable Gate Array
FPU	Focal Plane Unit
FTS	Fourier Transform Spectrometer
FWHM	Full Width Half maximum
GSFC	Goddard Space Flight Center
HK	House Keeping
HOB	Herschel Optical Bench
HPDU	Herschel Power Distribution Unit
HSDCU	Herschel-SPIRE Detector Control Unit
HSDPU	Herschel-SPIRE Digital Processing Unit
HSFCU	Herschel-SPIRE FPU Control Unit
HSO	Herschel Space Observatory
IF	Interface
IID-A	Instrument Interface Document - Part A
IID-B	Instrument Interface Document - Part B
IMF	Initial Mass Function



# SPIRE HARNES DEFINITION

Doc #: SPIRE-RAL-PRJ-000608

Issue: 0.7

Date: 19/09/01

Page 5 of 136

<b>Term</b>	<b>Meaning</b>
IR	Infrared
IRD	Instrument Requirements Document
IRTS	Infrared Telescope in Space
ISM	Interstellar Medium
JFET	Junction Field Effect Transistor
ISO	Infrared Space Observatory
LCL	Latching Current Limiter
LIA	Lock-In Amplifier
LVDT	Linear Variable Differential Transformer
MAC	Multi Axis Controller
LWS	Long Wave Spectrometer (an instrument used on ISO)
MCU	Mechanism Control Unit = HSMCU
M-P	Martin-Puplett
NEP	Noise Equivalent Power
NTD	Neutron Transmutation Doped
OBS	On-Board Software
OMD	Observing Modes Document
OPD	Optical Path Difference
PACS	Photodetector Array Camera and Spectrometer
PCAL	Photometer Calibration source
PID	Proportional, Integral and Differential (used in the context of feedback control loop architecture)
PLW	Photometer, Long Wavelength
PMW	Photometer, Medium Wavelength
POF	Photometer Observatory Function
PROM	Programmable Read Only Memory
PSW	Photometer, Short Wavelength
PUS	Packet Utilisation Standard
RMS	Root Mean Squared
SCAL	Spectrometer Calibration Source
SCUBA	Submillimetre Common User Bolometer Array
SED	Spectral Energy Distribution
SMEC	Spectrometer Mechanics
SMPS	Switch Mode Power Supply
SOB	SPIRE Optical Bench
SOF	Spectrometer Observatory Function
SPIRE	Spectral and Photometric Imaging Receiver
SRAM	Static Random Access Memory
SSSD	SubSystem Specification Document
STP	Standard Temperature and Pressure
SVM	Service Module
TBC	To Be Confirmed
TBD	To Be Determined
TC	Telecommand
URD	User Requirements Document
UV	Ultra Violet
WE	Warm Electronics
ZPD	Zero Path Difference



# SPIRE HARNES DEFINITION

Doc #: SPIRE-RAL-PRJ-000608  
Issue: 0.7  
Date: 19/09/01  
Page 6 of 136

## DISTRIBUTION LIST

Institute	Holder	Issue/ Revision and Distribution Date						
		0.1 28/3/01	0.2 11/4/01	0.3 10/5/01	0.4 10/8/01	0.5 22/8/01	0.6 15/9/01	0.7 19/9/01
RAL	Delderfield	x	x	x	x	x	x	x
	Swinyard	x	x	x	x	x	x	x
	Griffin	x	x	x	x	x	x	x
	Parker	x	x	x	x	x	x	x
	King	x	x	x	x	x	x	x
	Smith							
QMW	Griffin	x	x	x	x	x	x	x
	Hargrave	x	x	x	x	x	x	x
ATC	Cunningham	x	x	x	x	x	x	x
	Stobie	x	x	x	x	x	x	x
MSSL	Winter	x	x	x	x	x	x	x
CEA-SBT	Duband	x	x	x	x	x	x	x
CEA-SAP	Cara	x	x	x	x	x	x	x
	Auguères	x	x	x	x	x	x	x
	Pinsard	x	x	x	x	x	x	x
JPL	Bock	x	x	x	x	x	x	x
	Lilienthal	x	x	x	x	x	x	x
	Hristov	x	x	x	x	x	x	x
LAM	Pouliquen	x	x	x	x	x	x	x
	Ferrand							x
Can.	Taylor	x	x	x	x	x	x	x
	Peterson	x	x	x	x	x	x	x
ESA	Jackson	x	x	x	x	x	x	x
	Heske	x	x	x	x	x	x	x
	Bruston				x	x	x	x
CESR	Pons	x	x	x	x	x	x	x
IFSI	Giorgio	x	x	x	x	x	x	x
	Orfei	x	x	x	x	x	x	x
ALCATEL	Lund				x	x	x	x
Astrium	Fass						x	x
	Hoelzle							x



# SPIRE HARNESSES DEFINITION

Doc #: SPIRE-RAL-PRJ-000608  
Issue: 0.7  
Date: 19/09/01  
Page 7 of 136

## CONTENTS

<b>CHANGE RECORD</b> .....	<b>2</b>
<b>ACRONYM LIST</b> .....	<b>4</b>
<b>DISTRIBUTION LIST</b> .....	<b>6</b>
<b>1 SCOPE</b> .....	<b>9</b>
<b>2 APPLICABLE DOCUMENTS</b> .....	<b>9</b>
<b>3 INTRODUCTION</b> .....	<b>10</b>
<b>4 HARNESSES DETAILS</b> .....	<b>13</b>
4.1 WARM HARNESSES .....	13
4.1.1 W1 HSDPU-P to HSDCU-P.....	13
4.1.2 W2 HSDPU-R to HSDCU-R.....	14
4.1.3 W3 HSDPU-P to HSSCU-P.....	15
4.1.4 W4 HSDPU-R to HSSCU-R.....	16
4.1.5 W5 HSDPU-P to HSMCU-P .....	17
4.1.6 W6 HSDPU-R to HSMCU-R .....	18
4.1.7 W7 HSFCU-P to HSDCU-P.....	19
4.1.8 W8 HSFCU-R to HSDCU-R.....	20
4.2 INTERMEDIATE HARNESSES .....	21
4.2.1 I1 HSDCU to CVV1 Type3.....	21
4.2.2 I2 HSDCU to CVV2 Type4.....	26
4.2.3 I3 HSDCU to CVV3 Type2.....	30
4.2.4 I4 HSDCU to CVV4 Type1 .....	35
4.2.5 I5 HSDCU to CVV5 Type1 .....	39
4.2.6 I6 HSDCU to CVV6 Type1 .....	40
4.2.7 I7 HSDCU to CVV7 Type1 .....	41
4.2.8 I8 HSDCU to CVV8 Type1 .....	42
4.2.9 I9 HSDCU to CVV9 Type1 .....	43
4.2.10 I10 HSDCU to CVV10 AUX-P .....	44
4.2.11 I11 HSDCU to CVV11 DRV-P .....	48
4.2.12 I12 HSDCU to CVV12 AUX-R.....	52
4.2.13 I13 HSDCU to CVV13 DRV-R.....	53
4.3 CRYOGENIC HARNESSES.....	54
4.3.1 C1 CVV1 to HSJFS Type3.....	54
4.3.2 C2 CVV2 to HSJFS Type4.....	58
4.3.3 C3 CVV3 to HSJFP Type2.....	59
4.3.4 C4 CVV4 to HSJFP Type1.....	64
4.3.5 C5 CVV5 to HSJFP Type1.....	68
4.3.6 C6 CVV6 to HSJFP Type1.....	69
4.3.7 C7 CVV7 to HSJFP Type1.....	70
4.3.8 C8 CVV8 to HSJFP Type1.....	71
4.3.9 C9 CVV9 to HSJFP Type1.....	72
4.3.10 C10 CVV10 to HSFPU AUX-P.....	73
4.3.11 C11 CVV11 to HSFPU DRV-P.....	79
4.3.12 C12 CVV12 to HSFPU AUX-R.....	84
4.3.13 C13 CVV13 to HSFPU DRV-R.....	85



# SPIRE HARNESSES DEFINITION

Doc #: SPIRE-RAL-PRJ-000608  
Issue: 0.7  
Date: 19/09/01  
Page 8 of 136

4.4	FPU HARNESSES.....	86
4.4.1	F1[A&B] PSW-A BDA to HSJFP.....	86
4.4.2	F2[A&B] PSW-B BDA to HSJFP.....	88
4.4.3	F3[A&B] PSW-C BDA to HSJFP.....	89
4.4.4	F4[A&B] PSW-D BDA to HSJFP.....	90
4.4.5	F5[A&B] PSW-E BDA to HSJFP.....	91
4.4.6	F6[A&B] PSW-F BDA to HSJFP.....	92
4.4.7	F7[A&B] PMW-A BDA to HSJFP.....	93
4.4.8	F8[A&B] PMW-B BDA to HSJFP.....	94
4.4.9	F9[A&B] PMW-D BDA to HSJFP.....	95
4.4.10	F10[A&B] PMW-D BDA to HSJFP.....	96
4.4.11	F11[A&B] PLW-A BDA to HSJFP.....	97
4.4.12	F12[A&B] PLW-B BDA to HSJFP.....	98
4.4.13	F13[A&B] SSW-A BDA to HSJFS.....	99
4.4.14	F14[A&B] SSW-B BDA to HSJFS.....	100
4.4.15	F15[A&B] SLW-A BDA to HSJFS.....	101
4.4.16	F16 COOLER-P to FA.....	102
4.4.17	F17 COOLER-R to FA.....	103
4.4.18	F18 SPECT_STIM-P to FA.....	104
4.4.19	F19 SPECT_STIM-R to FD.....	105
4.4.20	F20 THERM-P from FA.....	106
4.4.21	F21 THERM-R from FE.....	107
4.4.22	F22 BSM-P to FB.....	108
4.4.23	F23 BSM-R to FE.....	109
4.4.24	F24 SMECSIG-P to FC.....	110
4.4.25	F25 SCECDRV-P to FC.....	111
4.4.26	F26 SMECSIG-R to FF.....	112
4.4.27	F27 SMECDRV-P to FF.....	113
4.5	JFET UNIT BACK-HARNESSES.....	114
4.5.1	Overview.....	114
4.5.2	BP-Photometer.....	116
4.5.3	BS-Spectrometer.....	120
4.6	TEST HARNESSES.....	122
4.6.1	T1 Primary 1553 Bus + Clock.....	122
4.6.2	T2 Secondary 1553 Bus + Clock.....	123
4.6.3	T3 DPU-P Power.....	124
4.6.4	T4 DPU-R Power.....	125
4.6.5	T5 FCU-P Power.....	126
4.6.6	T6 FCU-R Power.....	127
4.6.7	T7 SHT via FCU-P.....	128
4.6.8	T8 SHT via FCU-R.....	129
	<b>ANNEX. WIRING LIST.....</b>	<b>130</b>
	<b>BDA CHANNELS.....</b>	<b>135</b>
	<b>ADDENDUM: WHAT IS 12-AX?.....</b>	<b>135</b>
	<b>SPIRE GROUNDING DIAGRAM.....</b>	<b>136</b>





# SPIRE HARNES DEFINITION

Doc #: SPIRE-RAL-PRJ-000608  
Issue: 0.7  
Date: 19/09/01  
Page 9 of 136

## 1 SCOPE

This document at its latest issue is the primary definition of all HERSCHEL SPIRE flight harnesses.

It is an applicable document in the SPIRE IID-B, and as such is called up, and is applicable in full, to all SPIRE subsystems

It also contains information covering some test harnesses, but some harnesses / back-planes that stay entirely within sub-systems are not necessarily included.

Electrical and physical data are included, included contact functions, screening details, hold-down/shape details if appropriate, etc.. This information will become more detailed as designs are refined until it can be used as a basis for harness manufacture.

A conductor count/sizing summary list for the C/I series cryoharness is appended as an Annex and may, together with other summary information, be edited into the SPIRE IID-B. Spire is unusual in that these harnesses are not standard I/Fs between separately grounded systems but rather links within extended analogue systems. As such, the conductor count/sizing summary list alone is not an adequate specification to ensure the required performance, particularly w.r.t. consistency between ground calibration and flight performance.

The Spire instrument grounding diagram is appended.

## 2 APPLICABLE DOCUMENTS

ID	TITLE	NUMBER
AD-1	SPIRE Development Plan and Model Philosophy	SPIRE-RAL-PRJ-000035



### 3 INTRODUCTION

The overall HERSCHEL SPIRE harnesses are configured as shown:

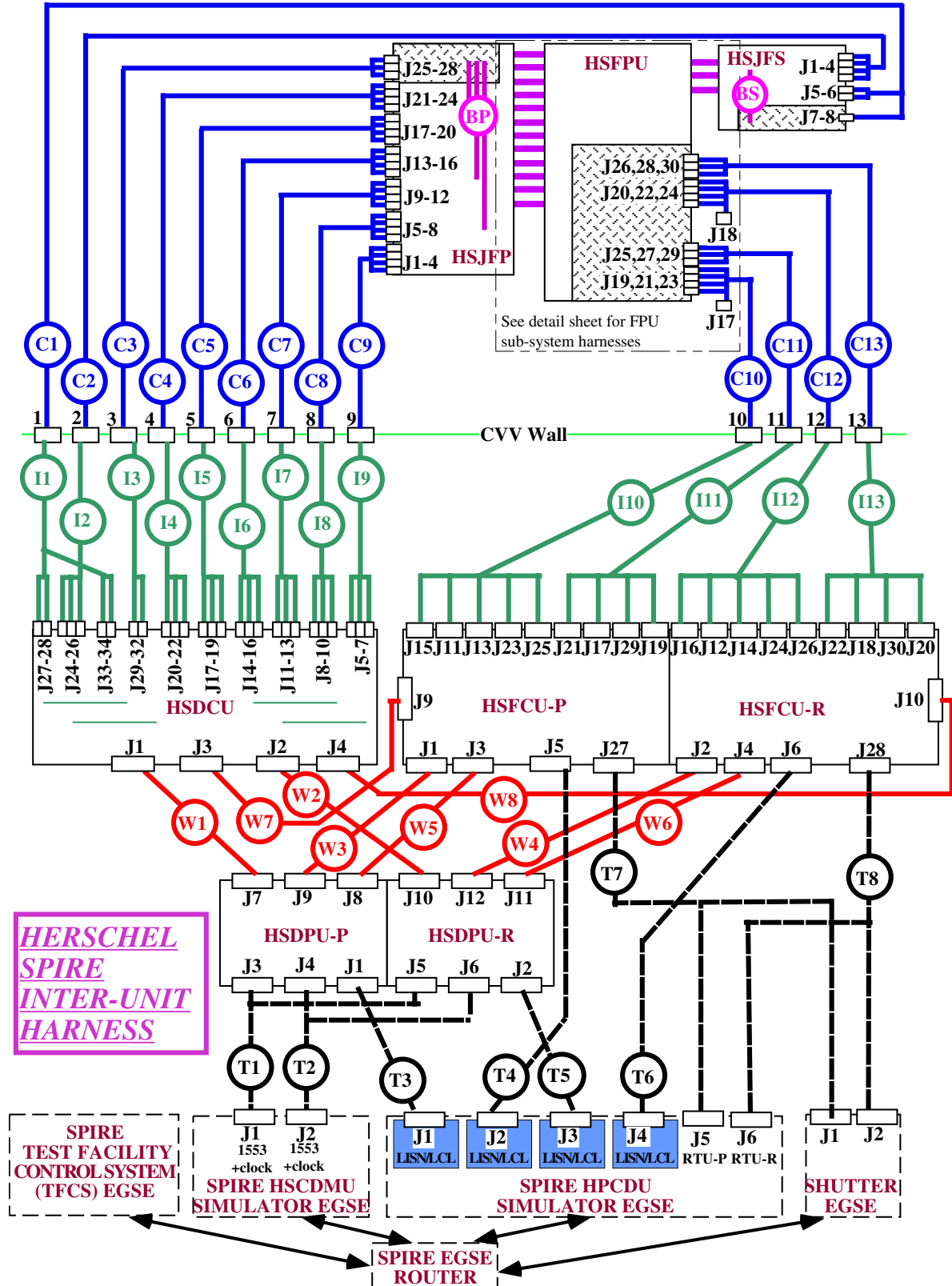



# SPIRE HARNES DEFINITION

Doc #: SPIRE-RAL-PRJ-000608  
Issue: 0.7  
Date: 19/09/01  
Page 11 of 136

The details in the HSFPU are as follows:

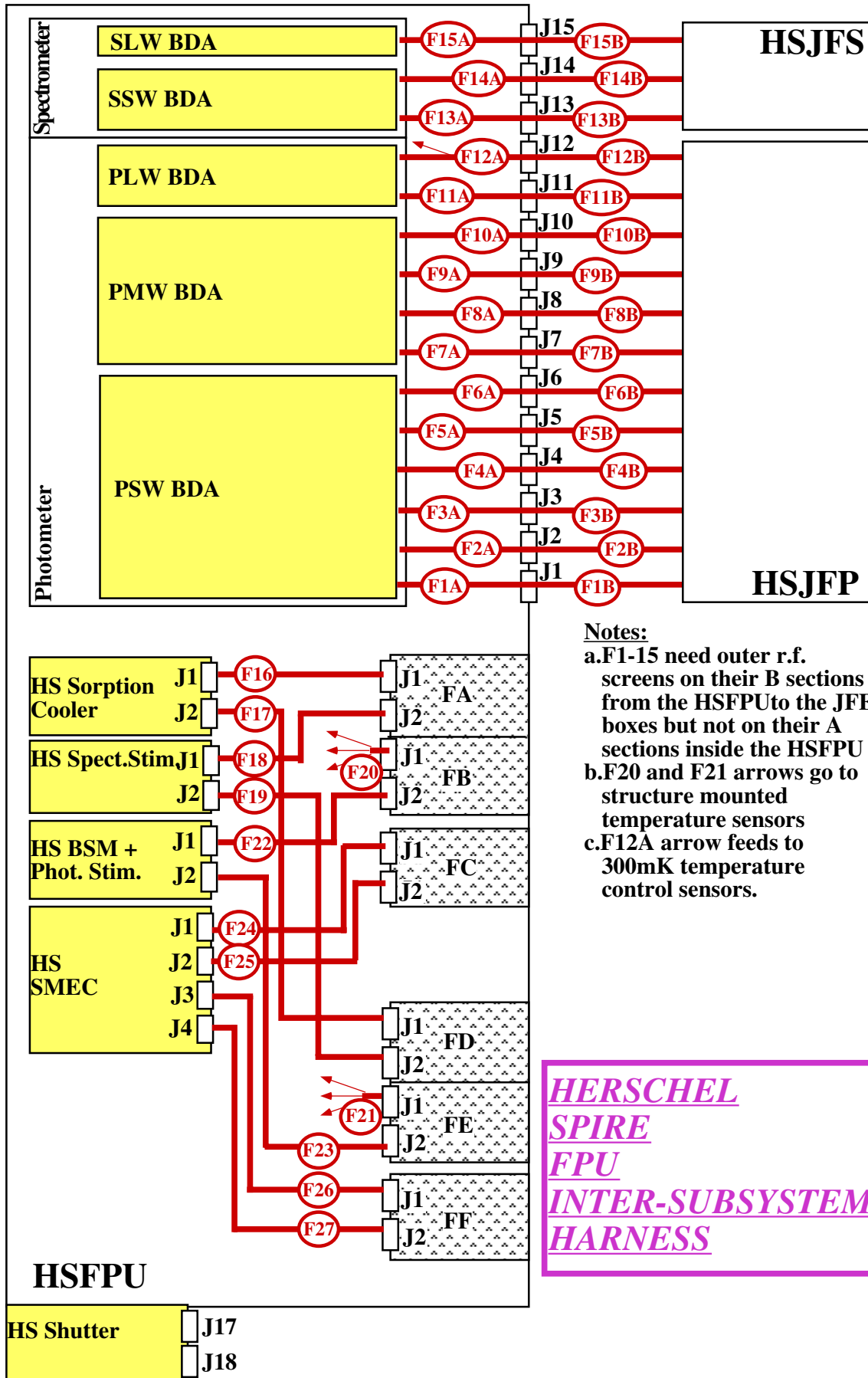

- Notes:**
- a. F1-15 need outer r.f. screens on their B sections from the HSFPU to the JFET boxes but not on their A sections inside the HSFPU
  - b. F20 and F21 arrows go to structure mounted temperature sensors
  - c. F12A arrow feeds to 300mK temperature control sensors.

**HERSCHEL  
SPIRE  
FPU  
INTER-SUBSYSTEM  
HARNES**



# SPIRE HARNESSES DEFINITION

Doc #: SPIRE-RAL-PRJ-000608

Issue: 0.7

Date: 19/09/01

Page 12 of 136

## Notes:

There are some "loop" harnesses that start and terminate within the same unit, such as on the HS DCU. These are treated as parts of the units rather than instrument harness.

The HSJFS + HSJFP "back-harnesses", BS and BP respectively, are now within the scope of this document as they permit the instrument 's architecture to be more clearly followed.

The Test harnesses, type T, are shown dashed as they are non-flight and will be substituted by ESA Contractor furnished items as SPIRE is integrated on to HERSCHEL. They will be RAL furnished for use with the instrument EGSE, but individual suppliers will need to make their own versions for unit level testing before delivery to the instrument.

The Cryogenic and Intermediate harnesses, types C and I, are RAL furnished for instrument level calibration but again are substituted by ESA Contractor furnished items as SPIRE is integrated on to HERSCHEL.

The FPU harnesses, F series, are each provided by the institute which sources the sub-system to which they connect.

The model philosophy definition, in AD-1, can be used to determine how many versions of each harness are required for the programme. For SPIRE it is necessary that most harnesses, of whatever version, are EMC and thermally representative.



# SPIRE HARNESS DEFINITION

Doc #: SPIRE-RAL-PRJ-000608  
Issue: 0.7  
Date: 19/09/01  
Page 13 of 136

## 4 HARNESS DETAILS

### 4.1 Warm Harnesses

#### 4.1.1 W1 HSDPU-P to HSDCU-P

##### Overall Mechanical Drwg.

1:1 harness of insulated screened 28AWG twisted pairs with backshell to backshell screen, covered on outside with insulation.

##### Connector/Backshell Details

Prime Side Harness

DBMA 25 P +XXXX to mate with DCU J1 t o DBMA 25 S +XXXX to mate with DPU J7

##### Harness Layup

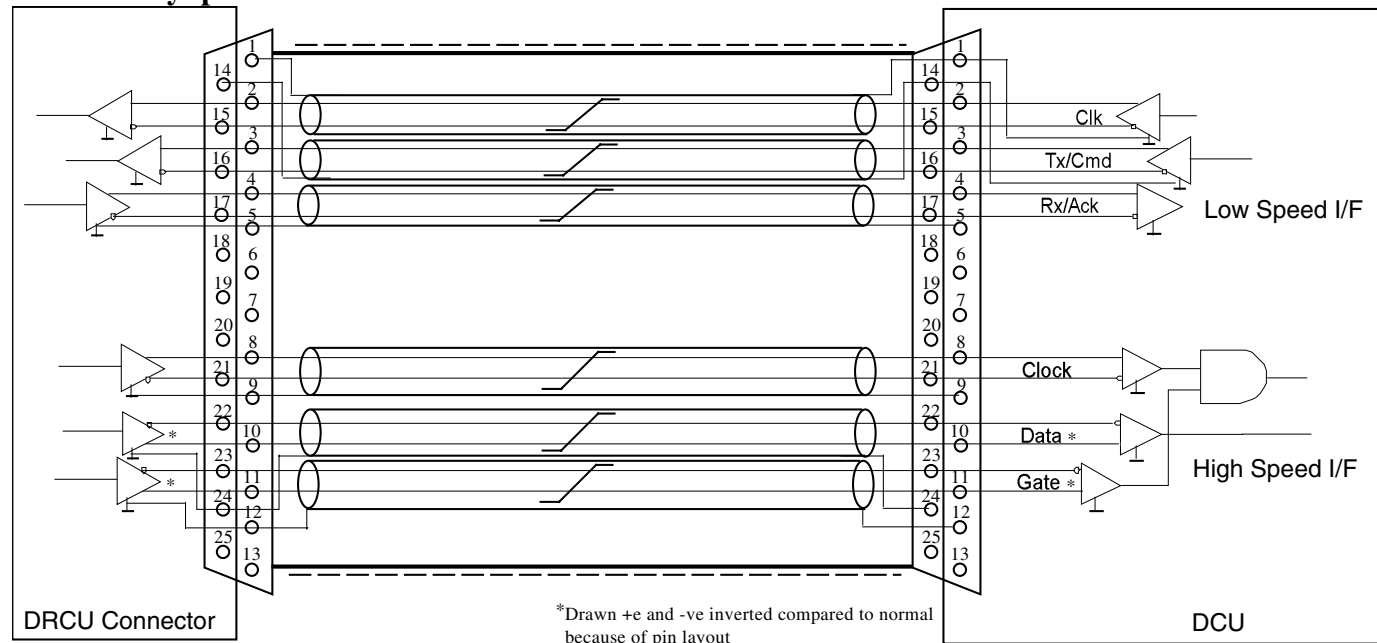

##### Contact Details

Wired 1:1 in harness

Signal Name	Pin	Wire	Signal Name	Pin	Wire
CLKS-DCU_P_shd	1	28AWG STP-A	CMD-DCU_P_shd	14	28AWG STP-B
CLKS-DCU_P_+	2	28AWG STP-A	CLKS-DCU_P_-	15	28AWG STP-A
CMD-DCU_P_+	3	28AWG STP-B	CMD-DCU_P_-	16	28AWG STP-B
ACK-DCU_P_+	4	28AWG STP-C	ACK-DCU_P_-	17	28AWG STP-C
ACK-DCU_P_shd	5	28AWG STP-C		18	
	6			19	
	7			20	
CLKF-DCU_P_+	8	28AWG STP-D	CLKF-DCU_P_-	21	28AWG STP-D
CLKF-DCU_P_shd	9	28AWG STP-D	DATA-DCU_P_-	22	28AWG STP-E
DATA-DCU_P_+	10	28AWG STP-E	GATE-DCU_P_-	23	28AWG STP-F
GATE-DCU_P_+	11	28AWG STP-F	DATA-DCU_P_shd	24	28AWG STP-E
GATE-DCU_P_shd	12	28AWG STP-F		25	
	13				



# SPIRE HARNES DEFINITION

Doc #: SPIRE-RAL-PRJ-000608  
Issue: 0.7  
Date: 19/09/01  
Page 14 of 136

## 4.1.2 W2 HSDPU-R to HSDCU-R

### Overall Mechanical Drwg.

1:1 harness of insulated screened 28AWG twisted pairs with backshell to backshell screen, covered on outside with insulation.

### Connector/Backshell Details

Redundant side harness

DBMA 25 P +XXXX to mate with DCU J2 t o DBMA 25 S +XXXX to mate with DPU J10

### Harness Layup

As W1

### Contact Details

Wired 1:1 in harness

Signal Name	Pin	Wire	Signal Name	Pin	Wire
CLKS-DCU_R_shd	1	28AWG STP-A	CMD-DCU_R_shd	14	28AWG STP-B
CLKS-DCU_R_+	2	28AWG STP-A	CLKS-DCU_R_-	15	28AWG STP-A
CMD-DCU_R_+	3	28AWG STP-B	CMD-DCU_R_-	16	28AWG STP-B
ACK-DCU_R_+	4	28AWG STP-C	ACK-DCU_R_-	17	28AWG STP-C
ACK-DCU_R_shd	5	28AWG STP-C		18	
	6			19	
	7			20	
CLKF-DCU_R_+	8	28AWG STP-D	CLKF-DCU_R_-	21	28AWG STP-D
CLKF-DCU_R_shd	9	28AWG STP-D	DATA-DCU_R_-	22	28AWG STP-E
DATA-DCU_R_+	10	28AWG STP-E	GATE-DCU_R_-	23	28AWG STP-F
GATE-DCU_R_+	11	28AWG STP-F	DATA-DCU_R_shd	24	28AWG STP-E
GATE-DCU_R_shd	12	28AWG STP-F		25	
	13				



# SPIRE HARNES DEFINITION

Doc #: SPIRE-RAL-PRJ-000608  
Issue: 0.7  
Date: 19/09/01  
Page 15 of 136

## 4.1.3 W3 HSDPU-P to HSSCU-P

### Overall Mechanical Drwg.

1:1 harness of insulated screened 28AWG twisted pairs with backshell to backshell screen, covered on outside with insulation.

### Connector/Backshell Details

Prime Side Harness

DBMA 25 P +XXXX to mate with FCU J1 t o DBMA 25 S +XXXX to mate with DPU J9

### Harness Layup

As W1

### Contact Details

Wired 1:1 in harness

Signal Name	Pin	Wire	Signal Name	Pin	Wire
CLKS-SCU_P_shd	1	28AWG STP-A	CMD-SCU_P_shd	14	28AWG STP-B
CLKS-SCU_P_+	2	28AWG STP-A	CLKS-SCU_P_-	15	28AWG STP-A
CMD-SCU_P_+	3	28AWG STP-B	CMD-SCU_P_-	16	28AWG STP-B
ACK-SCU_P_+	4	28AWG STP-C	ACK-SCU_P_-	17	28AWG STP-C
ACK-SCU_P_shd	5	28AWG STP-C		18	
	6			19	
	7			20	
CLKF-SCU_P_+	8	28AWG STP-D	CLKF-SCU_P_-	21	28AWG STP-D
CLKF-SCU_P_shd	9	28AWG STP-D	DATA-SCU_P_-	22	28AWG STP-E
DATA-SCU_P_+	10	28AWG STP-E	GATE-SCU_P_-	23	28AWG STP-F
GATE-SCU_P_+	11	28AWG STP-F	DATA-SCU_P_shd	24	28AWG STP-E
GATE-SCU_P_shd	12	28AWG STP-F		25	
	13				



# SPIRE HARNES DEFINITION

Doc #: SPIRE-RAL-PRJ-000608  
Issue: 0.7  
Date: 19/09/01  
Page 16 of 136

## 4.1.4 W4 HSDPU-R to HSSCU-R

### Overall Mechanical Drwg.

1:1 harness of insulated screened 28AWG twisted pairs with backshell to backshell screen, covered on outside with insulation.

### Connector/Backshell Details

Redundant side harness

DBMA 25 P +XXXX to mate with FCU J2 t o DBMA 25 S +XXXX to mate with DPU J12

### Harness Layup

As W1

### Contact Details

Wired 1:1 in harness

Signal Name	Pin	Wire	Signal Name	Pin	Wire
CLKS-SCU_R_shd	1	28AWG STP-A	CMD-SCU_R_shd	14	28AWG STP-B
CLKS-SCU_R_+	2	28AWG STP-A	CLKS-SCU_R_-	15	28AWG STP-A
CMD-SCU_R_+	3	28AWG STP-B	CMD-SCU_R_-	16	28AWG STP-B
ACK-SCU_R_+	4	28AWG STP-C	ACK-SCU_R_-	17	28AWG STP-C
ACK-SCU_R_shd	5	28AWG STP-C		18	
	6			19	
	7			20	
CLKF-SCU_R_+	8	28AWG STP-D	CLKF-SCU_R_-	21	28AWG STP-D
CLKF-SCU_R_shd	9	28AWG STP-D	DATA-SCU_R_-	22	28AWG STP-E
DATA-SCU_R_+	10	28AWG STP-E	GATE-SCU_R_-	23	28AWG STP-F
GATE-SCU_R_+	11	28AWG STP-F	DATA-SCU_R_shd	24	28AWG STP-E
GATE-SCU_R_shd	12	28AWG STP-F		25	
	13				





# SPIRE HARNES DEFINITION

Doc #: SPIRE-RAL-PRJ-000608  
Issue: 0.7  
Date: 19/09/01  
Page 17 of 136

## 4.1.5 W5 HSDPU-P to HSMCU-P

### Overall Mechanical Drwg.

1:1 harness of insulated screened 28AWG twisted pairs with backshell to backshell screen, covered on outside with insulation.

### Connector/Backshell Details

Prime Side Harness

DBMA 25 P +XXXX to mate with FCU J3 t o DBMA 25 S +XXXX to mate with DPU J8

### Harness Layup

As W1

### Contact Details

Wired 1:1 in harness

Signal Name	Pin	Wire	Signal Name	Pin	Wire
CLKS-MCU_P_shd	1	28AWG STP-A	CMD-MCU_P_shd	14	28AWG STP-B
CLKS-MCU_P_+	2	28AWG STP-A	CLKS-MCU_P_-	15	28AWG STP-A
CMD-MCU_P_+	3	28AWG STP-B	CMD-MCU_P_-	16	28AWG STP-B
ACK-MCU_P_+	4	28AWG STP-C	ACK-MCU_P_-	17	28AWG STP-C
ACK-MCU_P_shd	5	28AWG STP-C		18	
	6			19	
	7			20	
CLKF-MCU_P_+	8	28AWG STP-D	CLKF-MCU_P_-	21	28AWG STP-D
CLKF-MCU_P_shd	9	28AWG STP-D	DATA-MCU_P_-	22	28AWG STP-E
DATA-MCU_P_+	10	28AWG STP-E	GATE-MCU_P_-	23	28AWG STP-F
GATE-MCU_P_+	11	28AWG STP-F	DATA-MCU_P_shd	24	28AWG STP-E
GATE-MCU_P_shd	12	28AWG STP-F		25	
	13				



# SPIRE HARNES DEFINITION

Doc #: SPIRE-RAL-PRJ-000608  
Issue: 0.7  
Date: 19/09/01  
Page 18 of 136

## 4.1.6 W6 HSDPU-R to HSMCU-R

### Overall Mechanical Drwg.

1:1 harness of insulated screened 28AWG twisted pairs with backshell to backshell screen, covered on outside with insulation.

### Connector/Backshell Details

Redundant side harness

DBMA 25 P +XXXX to mate with FCU J4 t o DBMA 25 S +XXXX to mate with DPU J11

### Harness Layup

As W1

### Contact Details

Wired 1:1 in harness

Signal Name	Pin	Wire	Signal Name	Pin	Wire
CLKS-MCU_R_shd	1	28AWG STP-A	CMD-MCU_R_shd	14	28AWG STP-B
CLKS-MCU_R_+	2	28AWG STP-A	CLKS-MCU_R_-	15	28AWG STP-A
CMD-MCU_R_+	3	28AWG STP-B	CMD-MCU_R_-	16	28AWG STP-B
ACK-MCU_R_+	4	28AWG STP-C	ACK-MCU_R_-	17	28AWG STP-C
ACK-MCU_R_shd	5	28AWG STP-C		18	
	6			19	
	7			20	
CLKF-MCU_R_+	8	28AWG STP-D	CLKF-MCU_R_-	21	28AWG STP-D
CLKF-MCU_R_shd	9	28AWG STP-D	DATA-MCU_R_-	22	28AWG STP-E
DATA-MCU_R_+	10	28AWG STP-E	GATE-MCU_R_-	23	28AWG STP-F
GATE-MCU_R_+	11	28AWG STP-F	DATA-MCU_R_shd	24	28AWG STP-E
GATE-MCU_R_shd	12	28AWG STP-F		25	
	13				



# SPIRE HARNES DEFINITION

Doc #: SPIRE-RAL-PRJ-000608  
Issue: 0.7  
Date: 19/09/01  
Page 19 of 136

## 4.1.7 W7 HSFCU-P to HSDCU-P

### Overall Mechanical Drwg.

1:1

### Connector/Backshell Details

Prime side secondary power distribution harness

**DBMA 25 P** +XXXX to mate with FCU J9 t o **DBMA 25 S** +XXXX to mate with DCU J3

### Harness Layup

### Contact Details

TBC



**SPIRE**  
**HARNES DEFINITION**

Doc #: SPIRE-RAL-PRJ-000608  
Issue: 0.7  
Date: 19/09/01  
Page 20 of 136

**4.1.8 W8 HSFCU-R to HSDCU-R**

**Overall Mechanical Drwg.**

1:1

**Connector/Backshell Details**

Redundant side secondary power distribution harness

**DBMA 25 P** +XXXX to mate with FCU J10 t o **DBMA 25 S** +XXXX to mate with DCU J4

**Harness Layup**

As W7

**Contact Details**

As W7



# SPIRE HARNES DEFINITION

Doc #: SPIRE-RAL-PRJ-000608  
Issue: 0.7  
Date: 19/09/01  
Page 21 of 136

## 4.2 Intermediate Harnesses

### 4.2.1 I1 HSDCU to CVV1 Type3

#### Overall Mechanical Drwg.

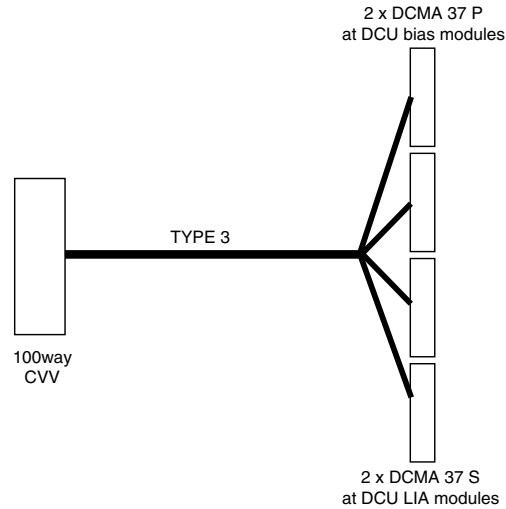

#### Connector/Backshell Details:

DCMA 37 S + XXXX: interface to HSDCU J27 12ch. bolometer  
 DCMA 37 S + XXXX: interface to HSDCU J28 12ch. bolometer  
 DCMA 37 P + XXXX: interface to HSDCU J33 Spect bias A  
 DCMA 37 P + XXXX: interface to HSDCU J34 Spect bias B

#### Harness Lay-up

Two Bolometers Tails thus:

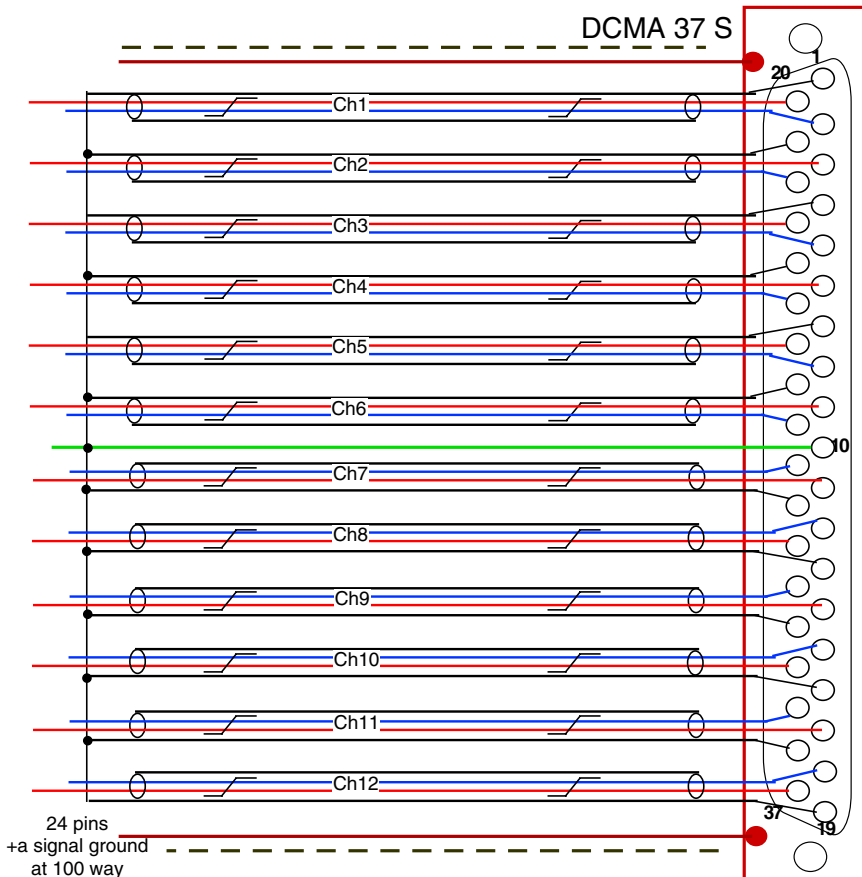

#### 12 Channel Bolometer Tail (typ) for Type 3 & Type4 Spectrometer Harness.

Common to all such tails, although others have ch. 13-24, etc.  
 Good flat layup for cryoharness

12 insulated screened twisted pairs plus 1 ground wire.

The whole overlain with RF screen shown: ——— joined to backshell CVV and DCU ends.

Dotted lines show insulation, probably put around bundles but only strictly needed at clamp points.



# SPIRE HARNESS DEFINITION

Doc #: SPIRE-RAL-PRJ-000608  
 Issue: 0.7  
 Date: 19/09/01  
 Page 22 of 136

Two Spectrometer Bias tails thus:

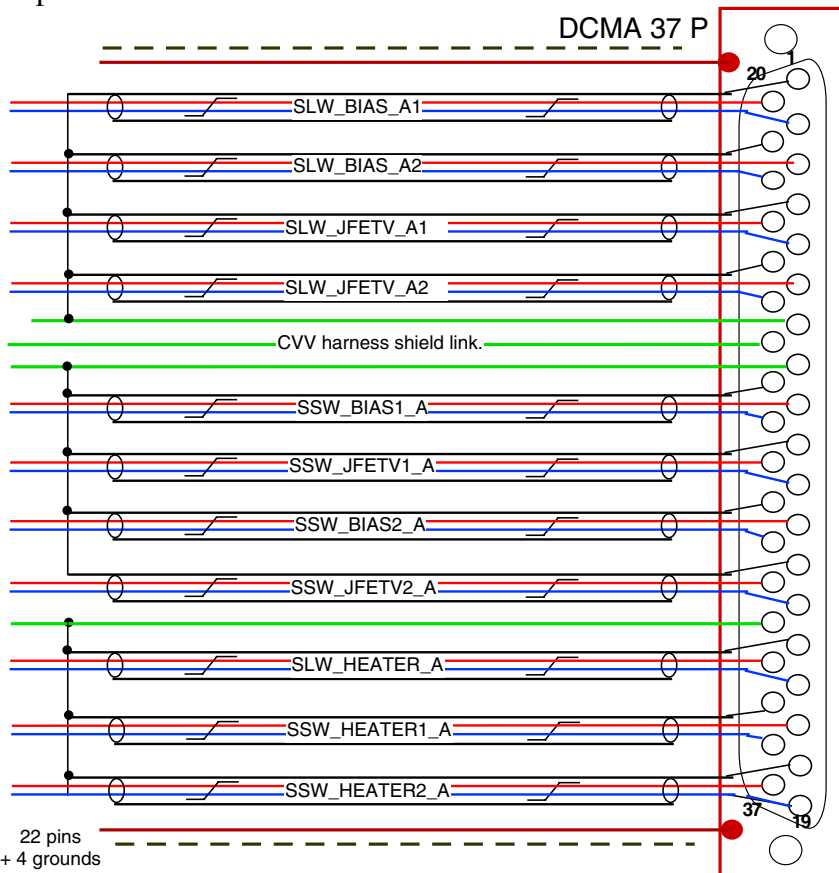

## DCU Type 3 Bias Tail

Two such tails, other with B instead of A at end of each name.

Good flat layup for cryoharness

11 insulated screened twisted pairs plus 3 ground wires.

The whole overlain with RF screen shown: ——— joined to backshell CVV and DCU ends.

Dotted lines show insulation, probably put around bundles but only strictly needed at clamp points.

### Contact Details

There are  $(22+24) \times 2 = 92$  signal wires, leaving 8 spare on the 100 way. There are actually 10 ground wires but they only have five functions, so some judicious pin sharing will be needed but note that this harness carries signal and bias for two BDAs, etc. so to keep the ground configuration loopfree the signal ground pins through the 100way are not all commoned together as in Type 1 harness

Name	100Way #1	37way A J27	37wayBJ28	37way C J33	37way D J34
Channel 1 +	TBD	20			
Channel 1 -	TBD	2			
Channel 1gnd shld	XXX	1			
Channel 2 +	TBD	3			
Channel 2 -	TBD	22			
Channel 2gnd shld	XXX	21			
Channel 3 +	TBD	23			
Channel 3 -	TBD	5			
Channel 3gnd shld	XXX	4			
Channel 4 +	TBD	6			
Channel 4 -	TBD	25			
Channel 4gnd shld	XXX	24			
Channel 5 +	TBD	26			
Channel 5 -	TBD	8			
Channel 5gnd shld	XXX	7			
Channel 6 +	TBD	9			
Channel 6 -	TBD	28			
Channel 6gnd shld	XXX	27			
SSW GND WIRE	XXX	10			
Channel 7 +	TBD	11			
Channel 7 -	TBD	29			
Channel 7gnd shld	XXX	30			



# SPIRE HARNES DEFINITION

Doc #: SPIRE-RAL-PRJ-000608

Issue: 0.7

Date: 19/09/01

Page 23 of 136

Name	100Way #1	37way A J27	37wayBJ28	37way C J33	37way D J34
Channel 8 +	TBD	31			
Channel 8 -	TBD	12			
Channel 8gnd shld	XXX	13			
Channel 9 +	TBD	14			
Channel 9 -	TBD	32			
Channel 9gnd shld	XXX	33			
Channel 10 +	TBD	34			
Channel 10 -	TBD	15			
Channel 10gnd shld	XXX	16			
Channel 11 +	TBD	17			
Channel 11 -	TBD	35			
Channel 11gnd shld	XXX	36			
Channel 12 +	TBD	37			
Channel 12 -	TBD	18			
Channel 12gnd shld	TBD	19			
Channel 13 +	TBD		20		
Channel 13 -	TBD		2		
Channel 1gnd shld	XXX		1		
Channel 14 +	TBD		3		
Channel 14 -	TBD		22		
Channel 1gnd shld	XXX		21		
Channel 15 +	TBD		23		
Channel 15 -	TBD		5		
Channel 15gnd shld	XXX		4		
Channel 16 +	TBD		6		
Channel 16 -	TBD		25		
Channel 16gnd shld	XXX		24		
Channel 17 +	TBD		26		
Channel 17 -	TBD		8		
Channel 17gnd shld	XXX		7		
Channel 18 +	TBD		9		
Channel 18 -	TBD		28		
Channel 18gnd shld	XXX		27		
SSW GND WIRE	XXX		10		
Channel 19 +	TBD		11		
Channel 19 -	TBD		29		
Channel 19gnd shld	XXX		30		
Channel 20 +	TBD		31		
Channel 20 -	TBD		12		
Channel 1gnd shld	XXX		13		
Channel 21 +	TBD		14		
Channel 21 -	TBD		32		
Channel 21gnd shld	XXX		33		
Channel 22 +	TBD		34		
Channel 22 -	TBD		15		
Channel 22gnd shld	XXX		16		
Channel 23 +	TBD		17		
Channel 23 -	TBD		35		
Channel 23gnd shld	XXX		36		
Channel 24 +	TBD		37		
Channel 24 -	TBD		18		
Channel 24gnd shld	TBD		19		
SLW_BIAS_A1+ve	TBD			20	
SLW_BIAS_A1-ve	TBD			2	
SLW_BIAS_A1 shld	XXX			1	
SLW_BIAS_A2 +ve	TBD			3	
SLW_BIAS_A2 -ve	TBD			22	
SLW_BIAS_A2 shld	XXX			21	



# SPIRE HARNES DEFINITION

Doc #: SPIRE-RAL-PRJ-000608

Issue: 0.7

Date: 19/09/01

Page 24 of 136

Name	100Way #1	37way A J27	37wayBJ28	37way C J33	37way D J34
SLW_JFETV_A1 +ve	TBD			23	
SLW_JFETV_A1 -ve	TBD			5	
SLW_JFETV_A1 shld	XXX			4	
SLW_JFETV_A2 +ve	TBD			6	
SLW_JFETV_A2 -ve	TBD			25	
SLW_JFETV_A2 shld	XXX			24	
SLW_GND WIRE_A	TBD			7	
CVV Harness Shield Link	TBD			26	
SSW_GND WIRE_A	TBD			8	
SSW_BIAS1_A +ve	TBD			9	
SSW_BIAS1_A -ve	TBD			28	
SSW_BIAS1_A shld	XXX			27	
SSW_JFETV1_A +ve	TBD			29	
SSW_JFETV1_A -ve	TBD			11	
SSW_JFETV1_A shld	XXX			10	
SSW_BIAS2_A +ve	TBD			12	
SSW_BIAS2_A -ve	TBD			31	
SSW_BIAS2_A shld	XXX			30	
SSW_JFETV2_A +ve	TBD			32	
SSW_JFETV2_A -ve	TBD			14	
SSW_JFETV2_A shld	XXX			13	
S_HEATER GROUND WIRE_A	TBD			33	
SLW_HEATER_A +ve	TBD			34	
SLW_HEATER_A -ve	TBD			16	
SLW_HEATER_A shld	XXX			15	
SSW_HEATER1_A +ve	TBD			17	
SSW_HEATER1_A -ve	TBD			36	
SSW_HEATER1_A shld	XXX			35	
SSW_HEATER2_A +ve	TBD			37	
SSW_HEATER2_A -ve	TBD			19	
SSW_HEATER2_A shld	XXX			18	
SLW_BIAS_B1+ve	TBD				20
SLW_BIAS_B1-ve	TBD				2
SLW_BIAS_B1 shld	XXX				1
SLW_BIAS_B2 +ve	TBD				3
SLW_BIAS_B2 -ve	TBD				22
SLW_BIAS_B2 shld	XXX				21
SLW_JFETV_B1 +ve	TBD				23
SLW_JFETV_B1 -ve	TBD				5
SLW_JFETV_B1 shld	XXX				4
SLW_JFETV_B2 +ve	TBD				6
SLW_JFETV_B2 -ve	TBD				25
SLW_JFETV_B2 shld	XXX				24
SLW_GND WIRE_B	TBD				7
SSW_GND WIRE_B	TBD				8
SSW_BIAS1_B +ve	TBD				9
SSW_BIAS1_B -ve	TBD				28
SSW_BIAS1_B shld	XXX				27
SSW_JFETV1_B +ve	TBD				29
SSW_JFETV1_B -ve	TBD				11
SSW_JFETV1_B shld	XXX				10
SSW_BIAS2_B +ve	TBD				12
SSW_BIAS2_B -ve	TBD				31
SSW_BIAS2_B shld	XXX				30
SSW_JFETV2_B +ve	TBD				32
SSW_JFETV2_B -ve	TBD				14
SSW_JFETV2_B shld	XXX				13
S_HEATER GROUND WIRE_B	TBD				33





# SPIRE HARNESS DEFINITION

Doc #: SPIRE-RAL-PRJ-000608  
Issue: 0.7  
Date: 19/09/01  
Page 25 of 136

Name	100Way #1	37way A J27	37wayBJ28	37way C J33	37way D J34
SLW_HEATER_B +ve	TBD				34
SLW_HEATER_B -ve	TBD				16
SLW_HEATER_B shld	XXX				15
SSW_HEATER1_B +ve	TBD				17
SSW_HEATER1_B -ve	TBD				36
SSW_HEATER1_B shld	XXX				35
SSW_HEATER2_B +ve	TBD				37
SSW_HEATER2_B -ve	TBD				19
SSW_HEATER2_B shld	XXX				18



# SPIRE HARNES DEFINITION

Doc #: SPIRE-RAL-PRJ-000608  
Issue: 0.7  
Date: 19/09/01  
Page 26 of 136

## 4.2.2 I2 HSDCU to CVV2 Type4

Overall Mechanical Drwg.

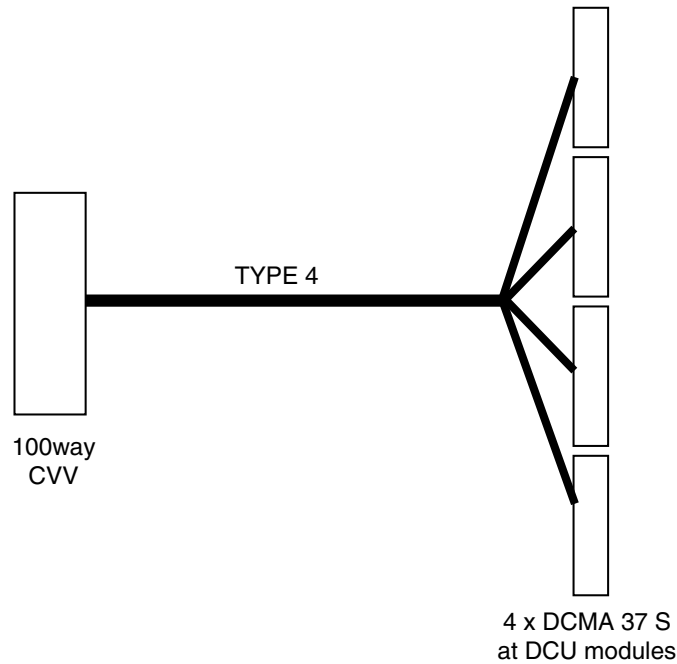

### Connector/Backshell Details

DCMA 37 S + XXXX: interface to HSDCU J23 12ch. bolometer  
DCMA 37 S + XXXX: interface to HSDCU J24 12ch. bolometer  
DCMA 37 S + XXXX: interface to HSDCU J25 12ch. bolometer  
DCMA 37 S + XXXX: interface to HSDCU J26 12ch. bolometer

### Harness Layup

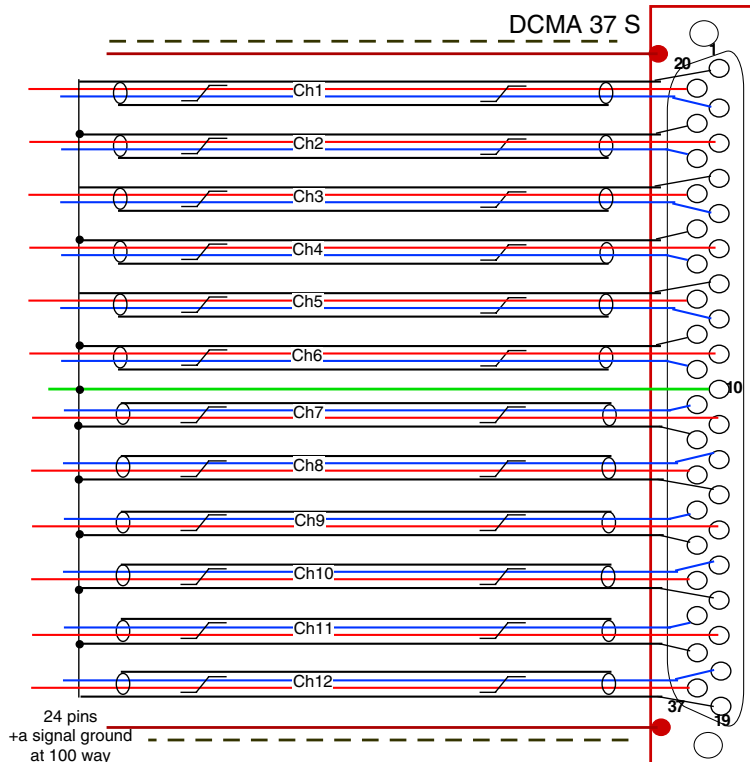

### 12 Channel Bolometer Tail (typ) for Type 3 & Type4 Spectrometer Harness.

Common to all such tails, although others have ch. 13-24, etc.  
Good flat layup for cryoharness

12 insulated screened twisted pairs plus 1 ground wire.

The whole overlain with RF screen shown: ——— joined to backshell CVV and DCU ends.

Dotted lines show insulation, probably put around bundles but only strictly needed at clamp points.



# SPIRE HARNES DEFINITION

Doc #: SPIRE-RAL-PRJ-000608  
 Issue: 0.7  
 Date: 19/09/01  
 Page 27 of 136

## Contact Details

Name	100Way #2	37way J23	37way J24	37way J25	37way J26
Channel 1 +	TBD	20			
Channel 1 -	TBD	2			
Channel 1gnd shld	XXX	1			
Channel 2 +	TBD	3			
Channel 2 -	TBD	22			
Channel 2gnd shld	XXX	21			
Channel 3 +	TBD	23			
Channel 3 -	TBD	5			
Channel 3gnd shld	XXX	4			
Channel 4 +	TBD	6			
Channel 4 -	TBD	25			
Channel 4gnd shld	XXX	24			
Channel 5 +	TBD	26			
Channel 5 -	TBD	8			
Channel 5gnd shld	XXX	7			
Channel 6 +	TBD	9			
Channel 6 -	TBD	28			
Channel 6gnd shld	XXX	27			
GND	XXX	10			
Channel 7 +	TBD	11			
Channel 7 -	TBD	29			
Channel 7gnd shld	XXX	30			
Channel 8 +	TBD	31			
Channel 8 -	TBD	12			
Channel 8gnd shld	XXX	13			
Channel 9 +	TBD	14			
Channel 9 -	TBD	32			
Channel 9gnd shld	XXX	33			
Channel 10 +	TBD	34			
Channel 10 -	TBD	15			
Channel 10gnd shld	XXX	16			
Channel 11 +	TBD	17			
Channel 11 -	TBD	35			
Channel 11gnd shld	XXX	36			
Channel 12 +	TBD	37			
Channel 12 -	TBD	18			
Channel 12gnd shld	TBD	19			
Channel 13 +	TBD		20		
Channel 13 -	TBD		2		
Channel 1gnd shld	XXX		1		
Channel 14 +	TBD		3		
Channel 14 -	TBD		22		
Channel 1gnd shld	XXX		21		
Channel 15 +	TBD		23		
Channel 15 -	TBD		5		
Channel 15gnd shld	XXX		4		
Channel 16 +	TBD		6		
Channel 16 -	TBD		25		
Channel 16gnd shld	XXX		24		
Channel 17 +	TBD		26		
Channel 17 -	TBD		8		
Channel 17gnd shld	XXX		7		
Channel 18 +	TBD		9		
Channel 18 -	TBD		28		
Channel 18gnd shld	XXX		27		
GND WIRE	XXX		10		
Channel 19 +	TBD		11		



# SPIRE HARNES DEFINITION

Doc #: SPIRE-RAL-PRJ-000608  
 Issue: 0.7  
 Date: 19/09/01  
 Page 28 of 136

Name	100Way #2	37way J23	37way J24	37way J25	37way J26
Channel 19 -	TBD		29		
Channel 19gnd shld	XXX		30		
Channel 20 +	TBD		31		
Channel 20 -	TBD		12		
Channel 1gnd shld	XXX		13		
Channel 21 +	TBD		14		
Channel 21 -	TBD		32		
Channel 21gnd shld	XXX		33		
Channel 22 +	TBD		34		
Channel 22 -	TBD		15		
Channel 22gnd shld	XXX		16		
Channel 23 +	TBD		17		
Channel 23 -	TBD		35		
Channel 23gnd shld	XXX		36		
Channel 24 +	TBD		37		
Channel 24 -	TBD		18		
Channel 24gnd shld	TBD		19		
Channel 25 +	TBD			20	
Channel 25 -	TBD			2	
Channel 25gnd shld	XXX			1	
Channel 26 +	TBD			3	
Channel 26 -	TBD			22	
Channel 26gnd shld	XXX			21	
Channel 27 +	TBD			23	
Channel 27 -	TBD			5	
Channel 27gnd shld	XXX			4	
Channel 28 +	TBD			6	
Channel 28 -	TBD			25	
Channel 28gnd shld	XXX			24	
Channel 29 +	TBD			26	
Channel 29 -	TBD			8	
Channel 29gnd shld	XXX			7	
Channel 30 +	TBD			9	
Channel 30 -	TBD			28	
Channel 30gnd shld	XXX			27	
GND WIRE	XXX			10	
Channel 31 +	TBD			11	
Channel 31 -	TBD			29	
Channel 31gnd shld	XXX			30	
Channel 32 +	TBD			31	
Channel 32 -	TBD			12	
Channel 32gnd shld	XXX			13	
Channel 33 +	TBD			14	
Channel 33 -	TBD			32	
Channel 33gnd shld	XXX			33	
Channel 34 +	TBD			34	
Channel 34 -	TBD			15	
Channel 34gnd shld	XXX			16	
Channel 35 +	TBD			17	
Channel 35 -	TBD			35	
Channel 35gnd shld	XXX			36	
Channel 36 +	TBD			37	
Channel 36 -	TBD			18	
Channel 36gnd shld	TBD			19	
Channel 37 +	TBD				20
Channel 37 -	TBD				2
Channel 37gnd shld	XXX				1
Channel 38 +	TBD				3



# SPIRE HARNES DEFINITION

Doc #: SPIRE-RAL-PRJ-000608  
Issue: 0.7  
Date: 19/09/01  
Page 29 of 136

Name	100Way #2	37way J23	37way J24	37way J25	37way J26
Channel 38 -	TBD				22
Channel 38gnd shld	XXX				21
Channel 39 +	TBD				23
Channel 39 -	TBD				5
Channel 39gnd shld	XXX				4
Channel 40 +	TBD				6
Channel 40 -	TBD				25
Channel 40gnd shld	XXX				24
Channel 41 +	TBD				26
Channel 41 -	TBD				8
Channel 41gnd shld	XXX				7
Channel 42 +	TBD				9
Channel 42 -	TBD				28
Channel 42gnd shld	XXX				27
GND WIRE	XXX				10
Channel 43 +	TBD				11
Channel 43 -	TBD				29
Channel 43gnd shld	XXX				30
Channel 44 +	TBD				31
Channel 44 -	TBD				12
Channel 44gnd shld	XXX				13
Channel 45 +	TBD				14
Channel 45 -	TBD				32
Channel 45gnd	XXX				33
Channel 46 +	TBD				34
Channel 46 -	TBD				15
Channel 46gnd shld	XXX				16
Channel 47 +	TBD				17
Channel 47 -	TBD				35
Channel 47gnd shld	XXX				36
Channel 48 +	TBD				37
Channel 48 -	TBD				18
Channel 48gnd shld	TBD				19

XXX= on ground wire ring, supported by the 4 otherwise unused contacts.

Although just 3 contacts could be used for the inner screens, leaving one to carry through the harness shield from inside the CVV, there is no-where to join this harness shield at the DCU connector end!



# SPIRE HARNES DEFINITION

Doc #: SPIRE-RAL-PRJ-000608  
Issue: 0.7  
Date: 19/09/01  
Page 30 of 136

## 4.2.3 I3 HSDCU to CVV3 Type2

### Overall Mechanical Drwg.

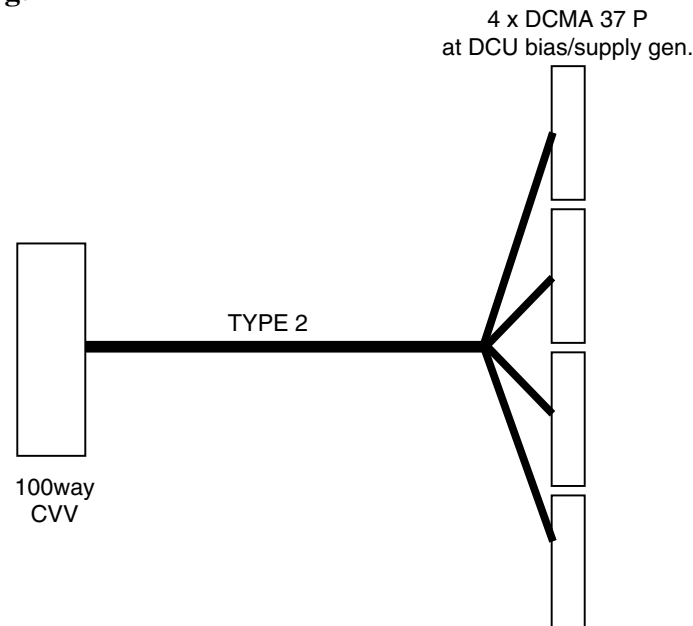

### Connector/Backshell Details

DCMA 37P + xxxxxx: interface to HSDCU J29 PHOT BIAS A1  
DCMA 37P + xxxxxx: interface to HSDCU J31 PHOT BIAS A2  
DCMA 37P + xxxxxx: interface to HSDCU J30 PHOT BIAS B1  
DCMA 37P + xxxxxx: interface to HSDCU J32 PHOT BIAS B2

### Harness Layup

There are  $(22+24) \times 2 = 92$  signal wires, leaving 8 spare on the 100 way. There are actually 10 ground wires but they only have five functions, so some judicious pin sharing will be needed but note that this harness carries grounds for various functions so to keep the ground configuration loopfree the signal ground pins through the 100way are not all commoned together as in Type 1 harness.

Contd. on next page.



# SPIRE HARNESS DEFINITION

Doc #: SPIRE-RAL-PRJ-000608  
Issue: 0.7  
Date: 19/09/01  
Page 31 of 136

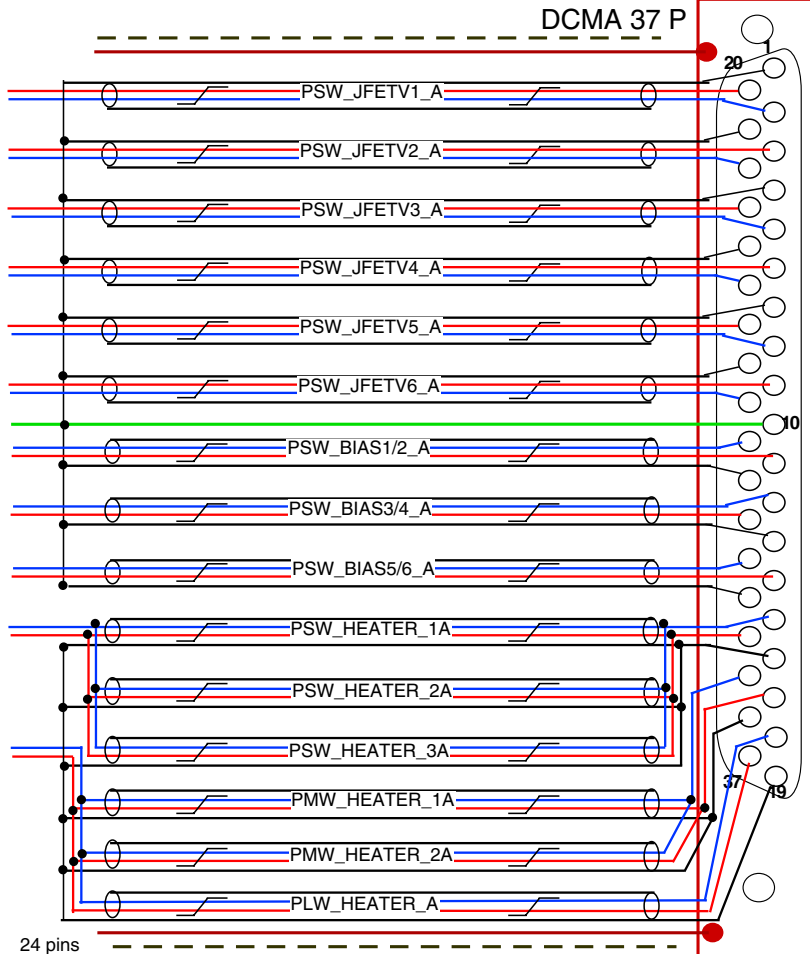

24 pins  
+signal ground  
at 100 way

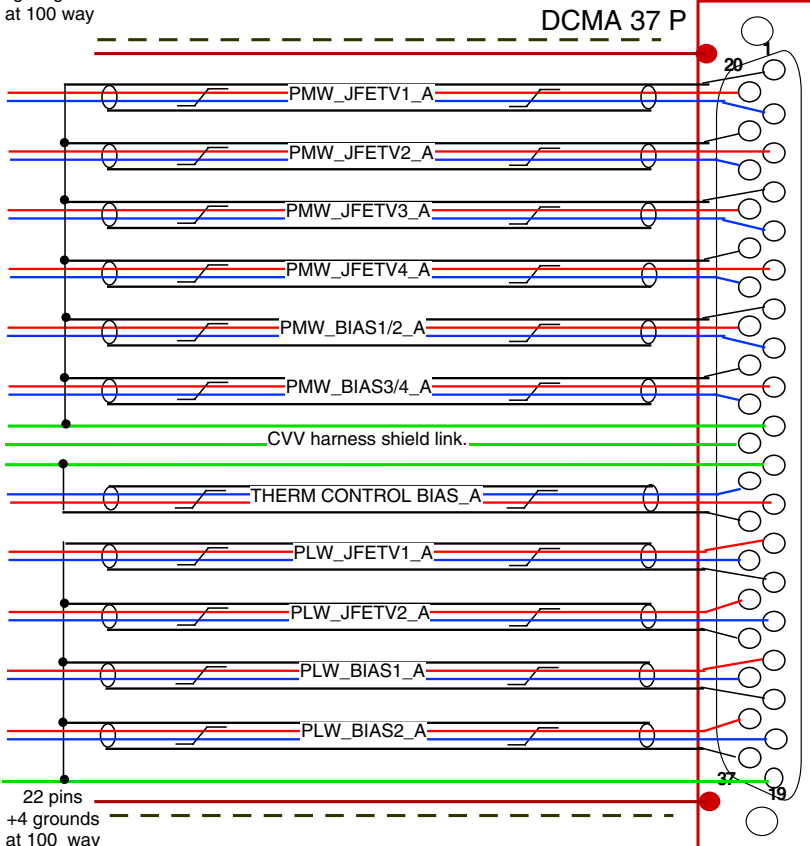

22 pins  
+4 grounds  
at 100 way

## Type 2 .....A Side Photometer Bias/Supply at DCU

Heaters parallel wired because assumed take takes same current as JFET supplies. May be simplified if heavier gauge can be used for heater wires.

Note ground separation on 2nd tail.

The whole overlain with RF screen shown: \_\_\_\_\_ joined to backshell CVV and DCU ends.

Dotted lines show insulation, probably put around bundles but only strictly needed at clamp points.

Note that for the other Bias tails change the last A in each name to B



# SPIRE HARNES DEFINITION

Doc #: SPIRE-RAL-PRJ-000608

Issue: 0.7

Date: 19/09/01

Page 32 of 136

## Contact Details

Name	100Way #3	37way J29	37way J31	37Way J30	37way J32
PSW_JFETV1_A +		20			
PSW_JFETV1_A -		2			
PSW_JFETV1_A shld		1			
PSW_JFETV2_A +		3			
PSW_JFETV2_A -		22			
PSW_JFETV2_A shld		21			
PSW_JFETV3_A +		23			
PSW_JFETV3_A -		4			
PSW_JFETV3_A shld		5			
PSW_JFETV4_A +		6			
PSW_JFETV4_A -		25			
PSW_JFETV4_A shld		24			
PSW_JFETV5_A +		26			
PSW_JFETV5_A -		8			
PSW_JFETV5_A shld		7			
PSW_JFETV6_A +		9			
PSW_JFETV6_A -		28			
PSW_JFETV6_A shld		27			
PSW_GRND_A		10			
PSW_BIAS1/2_A +		11			
PSW_BIAS1/2_A -		29			
PSW_BIAS1/2_A shld		30			
PSW_BIAS3/4_A +		31			
PSW_BIAS3/4_A -		12			
PSW_BIAS3/4_A shld		13			
PSW_BIAS5/6_A +		14			
PSW_BIAS5/6_A -		32			
PSW_BIAS5/6_A shld		33			
PSW_HEATER_A +x3		34			
PSW_HEATER_A -x3		15			
PSW_HEATER_A shldx3		16			
PMW_HEATER_A +x2		17			
PMW_HEATER_A -x2		35			
PMW_HEATER_A shldx2		36			
PLW_HEATER_A +		37			
PLW_HEATER_A -		18			
PLW_HEATER_A shld		19			
PMW_JFETV1_A +			20		
PMW_JFETV1_A -			2		
PMW_JFETV1_A shld			1		
PMW_JFETV2_A +			3		
PMW_JFETV2_A -			22		
PMW_JFETV2_A shld			21		
PMW_JFETV3_A +			23		
PMW_JFETV3_A -			5		
PMW_JFETV3_A shld			4		
PMW_JFETV4_A +			6		
PMW_JFETV4_A -			25		
PMW_JFETV4_A shld			24		
PMW_BIAS1/2_A +			26		
PMW_BIAS1/2_A -			8		
PMW_BIAS1/2_A shld			7		
PMW_BIAS3/4_A +			9		
PMW_BIAS3/4_A -			28		
PMW_BIAS3/4_A shld			27		
PMW_GND WIRE_A			10		
CVV Harness shld. Link_A			29		





# SPIRE HARNES DEFINITION

Doc #: SPIRE-RAL-PRJ-000608

Issue: 0.7

Date: 19/09/01

Page 33 of 136

Name	100Way #3	37way J29	37way J31	37Way J30	37way J32
THERM GND WIRE_A			11		
THERM CONTROL BIAS_A +			12		
THERM CONTROL BIAS_A -			30		
THERM CONTROL BIAS_A shld.			31		
PLW_JFETV1_A +			13		
PLW_JFETV1_A -			32		
PLW_JFETV1_A shld			15		
PLW_JFETV2_A +			33		
PLW_JFETV2_A -			15		
PLW_JFETV2_A shld			34		
PLW_BIAS1_A +			16		
PLW_BIAS1_A -			36		
PLW_BIAS1_A shld			17		
PLW_BIAS2_A +			37		
PLW_BIAS2_A -			18		
PLW_BIAS2_A shld			37		
PLW_A GND WIRE			19		
PSW_JFETV1_B +				20	
PSW_JFETV1_B -				2	
PSW_JFETV1_B shld				1	
PSW_JFETV2_B +				3	
PSW_JFETV2_B -				22	
PSW_JFETV2_B shld				21	
PSW_JFETV3_B +				23	
PSW_JFETV3_B -				4	
PSW_JFETV3_B shld				5	
PSW_JFETV4_B +				6	
PSW_JFETV4_B -				25	
PSW_JFETV4_B shld				24	
PSW_JFETV5_B +				26	
PSW_JFETV5_B -				8	
PSW_JFETV5_B shld				7	
PSW_JFETV6_B +				9	
PSW_JFETV6_B -				28	
PSW_JFETV6_B shld				27	
PSW GRND_B				10	
PSW_BIAS1/2_B +				11	
PSW_BIAS1/2_B -				29	
PSW_BIAS1/2_B shld				30	
PSW_BIAS3/4_B +				31	
PSW_BIAS3/4_B -				12	
PSW_BIAS3/4_B shld				13	
PSW_BIAS5/6_B +				14	
PSW_BIAS5/6_B -				32	
PSW_BIAS5/6_B shld				33	
PSW_HEATER_B +x3				34	
PSW_HEATER_B -x3				15	
PSW_HEATER_B shldx3				16	
PMW_HEATER_B +x2				17	
PMW_HEATER_B -x2				35	
PMW_HEATER_B shldx2				36	
PLW_HEATER_B +				37	
PLW_HEATER_B-				18	
PLW_HEATER_B shld				19	
PMW_JFETV1_B +					20
PMW_JFETV1_B -					2
PMW_JFETV1_B shld					1
PMW_JFETV2_B +					3



# SPIRE HARNES DEFINITION

Doc #: SPIRE-RAL-PRJ-000608  
 Issue: 0.7  
 Date: 19/09/01  
 Page 34 of 136

Name	100Way #3	37way J29	37way J31	37Way J30	37way J32
PMW_JFETV2_B -					22
PMW_JFETV2_B shld					21
PMW_JFETV3_B +					23
PMW_JFETV3_B -					5
PMW_JFETV3_B shld					4
PMW_JFETV4_B +					6
PMW_JFETV4_B -					25
PMW_JFETV4_B shld					24
PMW_BIAS1/2_B +					26
PMW_BIAS1/2_B -					8
PMW_BIAS1/2_B shld					7
PMW_BIAS3/4_B +					9
PMW_BIAS3/4_B -					28
PMW_BIAS3/4_B shld					27
PMW_GND_B					10
CVV Harness shld. Link B					29
Therm GND_B					11
THERM CONTROL BIAS_B +					12
THERM CONTROL BIAS_B -					30
THERM CONTROL BIAS_B shld.					31
PLW_JFETV1_B +					13
PLW_JFETV1_B -					32
PLW_JFETV1_B shld					15
PLW_JFETV2_B +					33
PLW_JFETV2_B -					15
PLW_JFETV2_B shld					34
PLW_BIAS1_B +					16
PLW_BIAS1_B -					36
PLW_BIAS1_B shld					17
PLW_BIAS2_B +					37
PLW_BIAS2_B -					18
PLW_BIAS2_B shld					37
PLW_B GND WIRE					19



# SPIRE HARNES DEFINITION

Doc #: SPIRE-RAL-PRJ-000608  
Issue: 0.7  
Date: 19/09/01  
Page 35 of 136

## 4.2.4 I4 HSDCU to CVV4 Type1

Overall Mechanical Drwg.

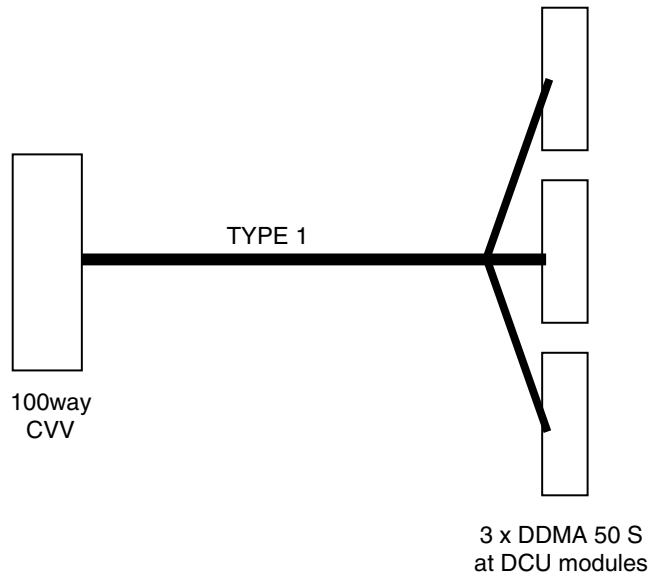

Connector/Backshell Details

DDMA 50 S + XXXX: interface to HSDCU J20 16ch. bolometer  
 DDMA 50 S + XXXX: interface to HSDCU J21 16ch. bolometer  
 DDMA 50 S + XXXX: interface to HSDCU J22 16ch. bolometer

Harness Layup

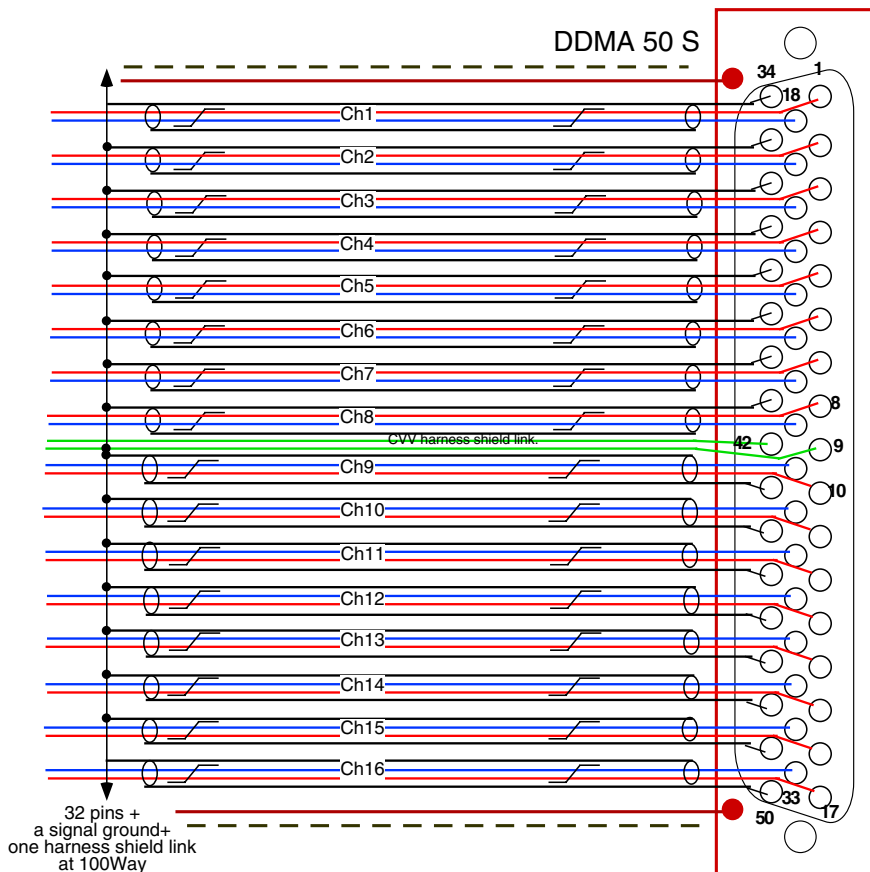

### Type 1 DCU tails

Common to all 3 tails, although others have ch. 17-32 and 33-48.  
 Good flat layup for cryoharness

16 insulated screen twisted pairs plus 2 ground pins with single higher conductivity signal gnd.

The whole overlain with RF screen shown: ——— joined to backshell CVV and DCU ends.

Dotted lines indicate insulation, probably put all around bundles but only strictly needed at clamp points.



# SPIRE HARNES DEFINITION

Doc #: SPIRE-RAL-PRJ-000608  
Issue: 0.7  
Date: 19/09/01  
Page 36 of 136

## Contact Details

Note the contacts are named as "channels 1-48" end-to-end, and mapping to specific detector position is only maintained internally to the instrument. The information is in the BDA ICDs.

Name	100Way #4	50way A	50wayB	50way C
Channel 1 +	TBD	1		
Channel 1 -	TBD	18		
Channel 1gnd shld	XXX	34		
Channel 2 +	TBD	2		
Channel 2 -	TBD	19		
Channel 2gnd shld	XXX	35		
Channel 3 +	TBD	3		
Channel 3 -	TBD	20		
Channel 3gnd shld	XXX	36		
Channel 4 +	TBD	4		
Channel 4 -	TBD	21		
Channel 4gnd shld	XXX	37		
Channel 5 +	TBD	5		
Channel 5 -	TBD	22		
Channel 5gnd shld	XXX	38		
Channel 6 +	TBD	6		
Channel 6 -	TBD	23		
Channel 6gnd shld	XXX	39		
Channel 7 +	TBD	7		
Channel 7 -	TBD	24		
Channel 7gnd shld	XXX	40		
Channel 8 +	TBD	8		
Channel 8 -	TBD	25		
Channel 8gnd shld	XXX	41		
GND WIRE	XXX	9		
Harness Shield Link	XXX	42		
Channel 9 +	TBD	10		
Channel 9 -	TBD	26		
Channel 9gnd shld	XXX	43		
Channel 10 +	TBD	11		
Channel 10 -	TBD	27		
Channel 10gnd shld	XXX	44		
Channel 11 +	TBD	12		
Channel 11 -	TBD	28		
Channel 11gnd shld	XXX	45		
Channel 12 +	TBD	13		
Channel 12 -	TBD	29		
Channel 12gnd shld	TBD	46		
Channel 13 +	TBD	14		
Channel 13 -	TBD	30		
Channel 1gnd shld	XXX	47		
Channel 14 +	TBD	15		
Channel 14 -	TBD	31		
Channel 1gnd shld	XXX	48		
Channel 15 +	TBD	16		
Channel 15 -	TBD	32		
Channel 15gnd shld	XXX	49		
Channel 16 +	TBD	17		
Channel 16 -	TBD	33		
Channel 16gnd shld	XXX	50		
Channel 17 +	TBD		1	
Channel 17 -	TBD		18	
Channel 17gnd shld	XXX		34	
Channel 18 +	TBD		2	



# SPIRE HARNES DEFINITION

Doc #: SPIRE-RAL-PRJ-000608

Issue: 0.7

Date: 19/09/01

Page 37 of 136

Name	100Way #4	50way A	50wayB	50way C
Channel 18 -	TBD		19	
Channel 18gnd shld	XXX		35	
Channel 19 +	TBD		3	
Channel 19 -	TBD		20	
Channel 19gnd shld	XXX		36	
Channel 20 +	TBD		4	
Channel 20 -	TBD		21	
Channel 1gnd shld	XXX		37	
Channel 21 +	TBD		5	
Channel 21 -	TBD		22	
Channel 21gnd shld	XXX		38	
Channel 22 +	TBD		6	
Channel 22 -	TBD		23	
Channel 22gnd shld	XXX		39	
Channel 23 +	TBD		7	
Channel 23 -	TBD		24	
Channel 23gnd shld	XXX		40	
Channel 24 +	TBD		8	
Channel 24 -	TBD		25	
Channel 24gnd shld	TBD		41	
GND WIRE	XXX		9	
Harness Shield Link	XXX		42	
Channel 25 +	TBD		10	
Channel 25 -	TBD		26	
Channel 25gnd shld	XXX		43	
Channel 26 +	TBD		11	
Channel 26 -	TBD		27	
Channel 26gnd shld	XXX		44	
Channel 27 +	TBD		12	
Channel 27 -	TBD		28	
Channel 27gnd shld	XXX		45	
Channel 28 +	TBD		13	
Channel 28 -	TBD		29	
Channel 28gnd shld	XXX		46	
Channel 29 +	TBD		14	
Channel 29 -	TBD		30	
Channel 29gnd shld	XXX		47	
Channel 30 +	TBD		15	
Channel 30 -	TBD		31	
Channel 30gnd shld	XXX		48	
Channel 31 +	TBD		16	
Channel 31 -	TBD		32	
Channel 31gnd shld	XXX		49	
Channel 32 +	TBD		17	
Channel 32 -	TBD		33	
Channel 32gnd shld	XXX		50	
Channel 33 +	TBD			1
Channel 33 -	TBD			18
Channel 33gnd shld	XXX			34
Channel 34 +	TBD			2
Channel 34 -	TBD			19
Channel 34gnd shld	XXX			35
Channel 35 +	TBD			3
Channel 35 -	TBD			20
Channel 35gnd shld	XXX			36
Channel 36 +	TBD			4
Channel 36 -	TBD			21
Channel 36gnd shld	TBD			37



# SPIRE HARNES DEFINITION

Doc #: SPIRE-RAL-PRJ-000608  
Issue: 0.7  
Date: 19/09/01  
Page 38 of 136

Name	100Way #4	50way A	50wayB	50way C
Channel 37 +	TBD			5
Channel 37 -	TBD			22
Channel 37gnd shld	XXX			38
Channel 38 +	TBD			6
Channel 38 -	TBD			23
Channel 38gnd shld	XXX			39
Channel 39 +	TBD			7
Channel 39 -	TBD			24
Channel 39gnd shld	XXX			40
Channel 40 +	TBD			8
Channel 40 -	TBD			25
Channel 40gnd shld	XXX			41
GND WIRE	XXX			9
Harness Shield Link	XXX			42
Channel 41 +	TBD			10
Channel 41 -	TBD			26
Channel 41gnd shld	XXX			43
Channel 42 +	TBD			11
Channel 42 -	TBD			27
Channel 42gnd shld	XXX			44
Channel 43 +	TBD			12
Channel 43 -	TBD			28
Channel 43gnd shld	XXX			45
Channel 44 +	TBD			13
Channel 44 -	TBD			29
Channel 44gnd shld	XXX			46
Channel 45 +	TBD			14
Channel 45 -	TBD			30
Channel 45gnd shld	XXX			47
Channel 46 +	TBD			15
Channel 46 -	TBD			31
Channel 46gnd shld	XXX			48
Channel 47 +	TBD			16
Channel 47 -	TBD			32
Channel 47gnd shld	XXX			49
Channel 48 +	TBD			17
Channel 48 -	TBD			33
Channel 48gnd shld	TBD			50

XXX= on ground wire ring, supported by thtree of the 4 otherwise unused contacts.



# SPIRE HARNES DEFINITION

Doc #: SPIRE-RAL-PRJ-000608  
Issue: 0.7  
Date: 19/09/01  
Page 39 of 136

## 4.2.5 I5 HSDCU to CVV5 Type1

Overall Mechanical Drwg.

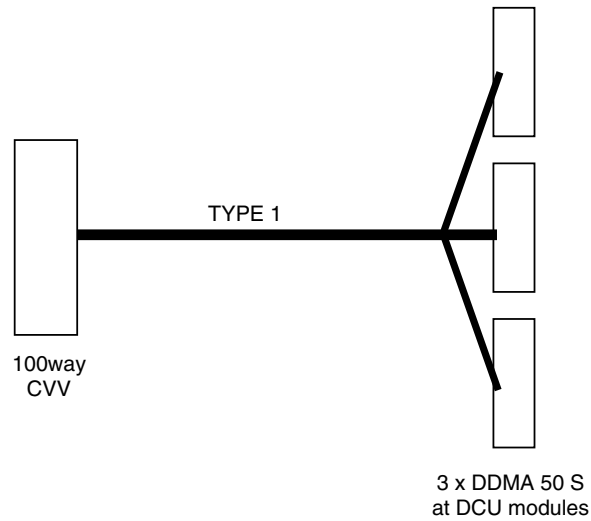

### Connector/Backshell Details

DDMA 50 S + XXXX: interface to HSDCU J17 16ch. bolometer  
DDMA 50 S + XXXX: interface to HSDCU J18 16ch. bolometer  
DDMA 50 S + XXXX: interface to HSDCU J19 16ch. bolometer

### Harness Layup

As I 4.

### Contact Details

As I 4.



# SPIRE HARNES DEFINITION

Doc #: SPIRE-RAL-PRJ-000608  
Issue: 0.7  
Date: 19/09/01  
Page 40 of 136

## 4.2.6 I6 HSDCU to CVV6 Type1

Overall Mechanical Drwg.

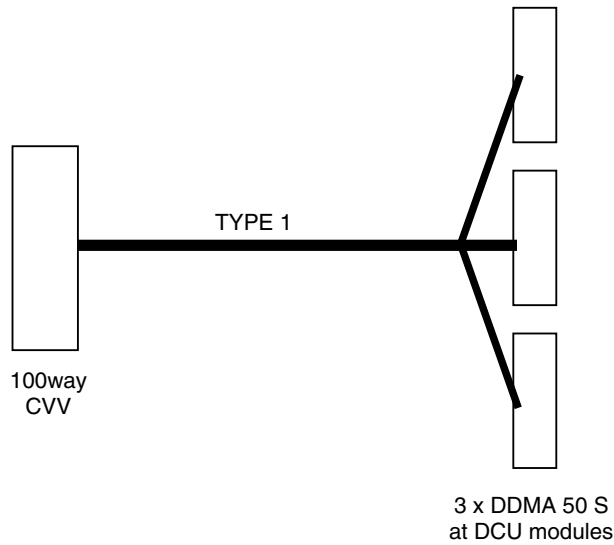

### Connector/Backshell Details

DDMA 50 S + XXXX: interface to HSDCU J14 16ch. bolometer  
DDMA 50 S + XXXX: interface to HSDCU J15 16ch. bolometer  
DDMA 50 S + XXXX: interface to HSDCU J16 16ch. bolometer

### Harness Layup

As I 4.

### Contact Details

As I 4.





# SPIRE HARNES DEFINITION

Doc #: SPIRE-RAL-PRJ-000608  
Issue: 0.7  
Date: 19/09/01  
Page 41 of 136

## 4.2.7 I7 HSDCU to CVV7 Type1

Overall Mechanical Drwg.

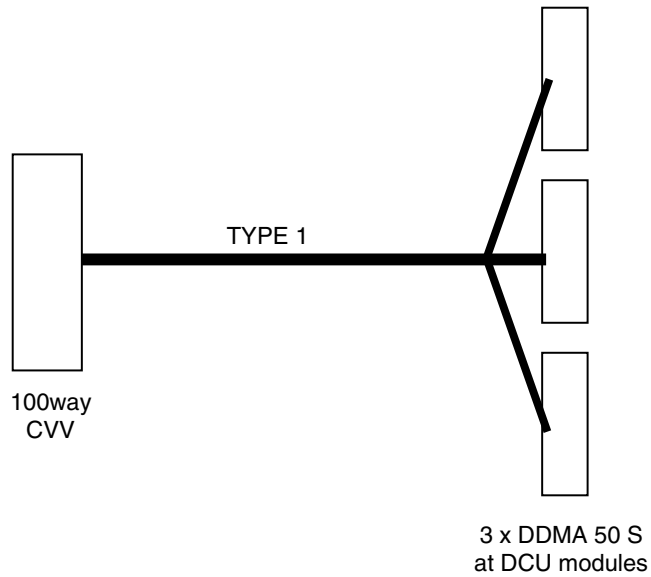

### Connector/Backshell Details

DDMA 50 S + XXXX: interface to HSDCU J11 16ch. bolometer  
DDMA 50 S + XXXX: interface to HSDCU J12 16ch. bolometer  
DDMA 50 S + XXXX: interface to HSDCU J13 16ch. bolometer

### Harness Layup

As I 4.

### Contact Details

As I 4.



# SPIRE HARNES DEFINITION

Doc #: SPIRE-RAL-PRJ-000608  
Issue: 0.7  
Date: 19/09/01  
Page 42 of 136

## 4.2.8 I8 HSDCU to CVV8 Type1

Overall Mechanical Drwg.

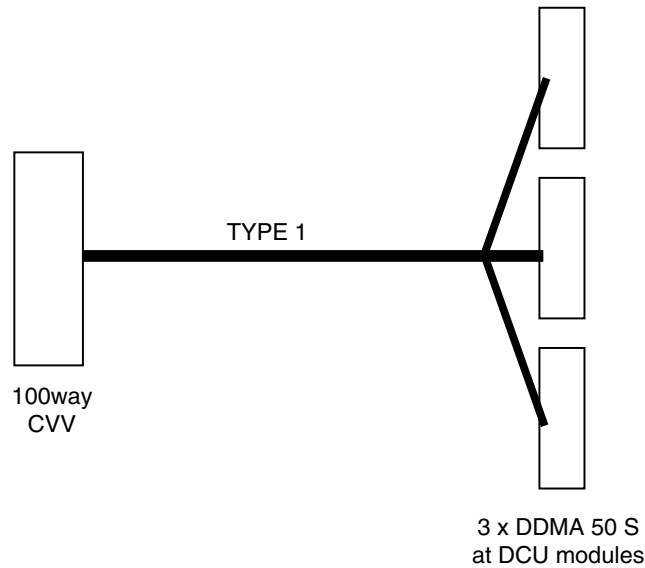

### Connector/Backshell Details

DDMA 50 S + XXXX: interface to HSDCU J8 16ch. bolometer  
DDMA 50 S + XXXX: interface to HSDCU J9 16ch. bolometer  
DDMA 50 S + XXXX: interface to HSDCU J10 16ch. bolometer

### Harness Layup

As I 4.

### Contact Details

As I 4.



# SPIRE HARNES DEFINITION

Doc #: SPIRE-RAL-PRJ-000608  
Issue: 0.7  
Date: 19/09/01  
Page 43 of 136

## 4.2.9 I9 HSDCU to CVV9 Type1

Overall Mechanical Drwg.

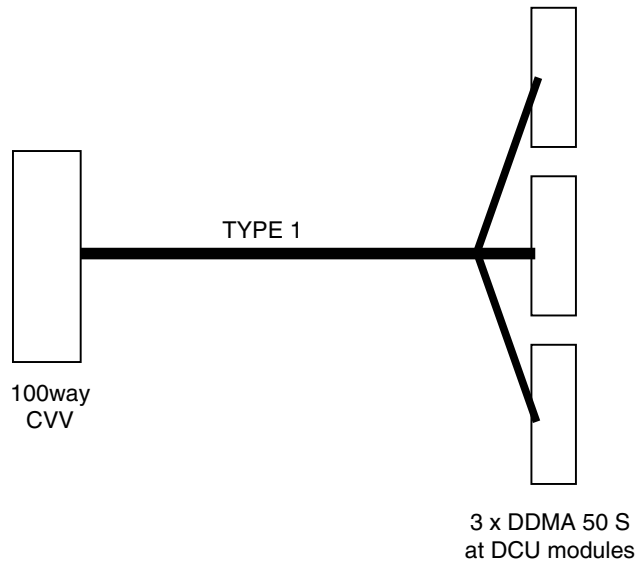

### Connector/Backshell Details

DDMA 50 S + XXXX: interface to HSDCU J5 16ch. bolometer  
DDMA 50 S + XXXX: interface to HSDCU J6 16ch. bolometer  
DDMA 50 S + XXXX: interface to HSDCU J7 16ch. bolometer

### Harness Layup

As I 4.

### Contact Details

As I 4.



# SPIRE HARNESS DEFINITION

Doc #: SPIRE-RAL-PRJ-000608  
Issue: 0.7  
Date: 19/09/01  
Page 44 of 136

## 4.2.10 I10 HSDCU to CVV10 AUX-P

### Overall Mechanical Drwg.

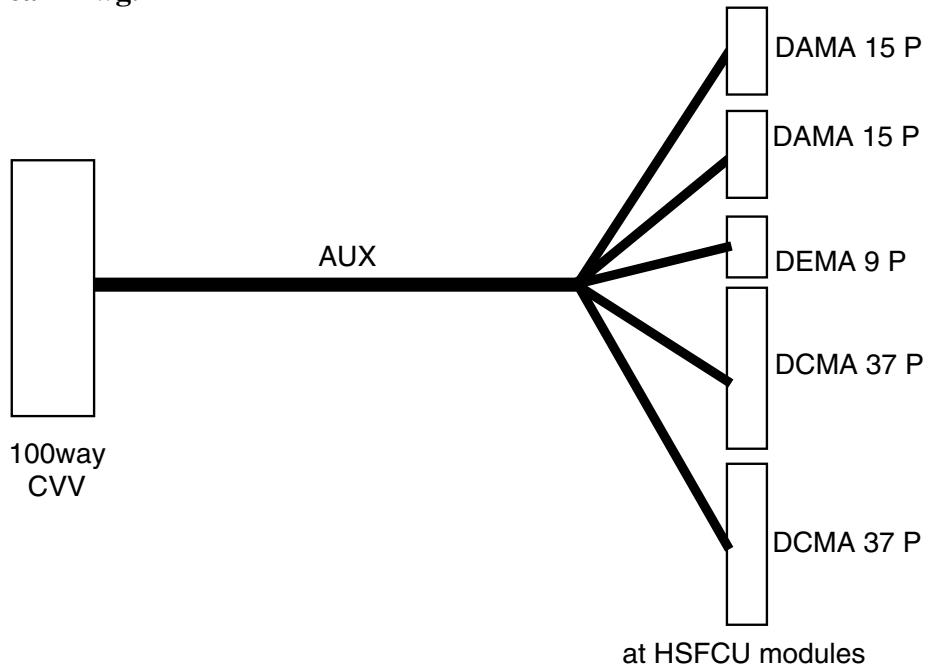

### Connector/Backshell Details

Prime side harness

DAMA 15 P + XXXX: interface to HSFCU J15 Shutter

DAMA 15 P + XXXX: interface to HSFCU J11 Cooler

DMA 9 P + XXXX: interface to HSFCU J13 FTS Stimulus

DCMA 37 P + XXXX: interface to HSFCU J23 Temperature sensors A

DCMA 37 P + XXXX: interface to HSFCU J25 Temperature sensors B



# SPIRE HARNESS DEFINITION

Doc #: SPIRE-RAL-PRJ-000608  
Issue: 0.7  
Date: 19/09/01  
Page 45 of 136

## Shutter Tail J15

Function	Pin # on J15	Max Current	Wire lay-up	Max Ohms*
Actuator Position Sensor +	1		Insulated screened twisted quad	1000
Actuator Position Sensor -	9			1000
Latch Sense +	2			1000
Latch Sense -	10			1000
Sense Shld	3			1000
Latch Drive +	11		Insulated screened twisted quad	10
Vane Heater+	4			10
Stepper Drive Phase A +	12			10
Stepper Drive Phase B +	5			10
Power Ground / Rtn. as shld	13			10
Temp Sensor Bias+	6		Insulated screened twisted quad	1000
Vane Temp V+	14			1000
Common Temp V	7			1000
Actuator Temp V-	15			1000
Temp Sensor Bias -/Shld	8			1000

All 15 ways used

## Cooler Tail Listing J11

Function	15way J11	Max. current	Wire lay-up	Max Ohms	100way #10
Sorption Pump heater I+ _A	1	25 mA	twisted quad	10	
Sorption Pump heater I+ _B	2	25 mA		10	
Sorption Pump heater I- _A	9	25 mA		10	
Sorption Pump heater I- _B	10	25 mA		10	
Sorption Pump Heat Switch heater I+ _A	4	1.5 mA	twisted quad	50	
Sorption Pump Heat Switch heater I+ _B	5	1.5 mA		50	
Sorption Pump Heat Switch heater I- _A	11	1.5 mA		50	
Sorption Pump Heat Switch heater I- _B	12	1.5 mA		50	
Evaporator Heat Switch heater I+ _A	7	1.5 mA	twisted quad	50	
Evaporator Heat Switch heater I+ _B	8	1.5 mA		50	
Evaporator Heat Switch heater I- _A	14	1.5 mA		50	
Evaporator Heat Switch heater I- _B	15	1.5 mA		50	

12 ways used.

## Spectrometer Stimulus Tail Listing J13

Function	9way J13	Max. current	Wire lay-up	Max Ohms	100way #10
HS Spect. 4% heater I+ _A	1	9 mA	twisted quad	30	
HS Spect. 4% heater I+ _B	2	9 mA		30	
HS Spect. 4% heater I- _A	6	9 mA		30	
HS Spect. 4% heater I- _B	7	9 mA		30	
HS Spect. 2% heater I+ _A	3	7 mA	twisted quad	30	
HS Spect. 2% heater I+ _B	4	7 mA		30	
HS Spect. 2% heater I- _A	8	7 mA		30	
HS Spect. 2% heater I- _B	9	7 mA		30	

8 ways used



# SPIRE HARNESS DEFINITION

Doc #: SPIRE-RAL-PRJ-000608  
 Issue: 0.7  
 Date: 19/09/01  
 Page 46 of 136

## FPU Thermometry Listing A J23

Function	37way J23	Max. current	Wire lay-up	Max Ohms	100way #10
HSFPU Opt. Bench temperature I+		1 $\mu$ A	Insulated screened twisted quad	1000	
HSFPU Opt. Bench temperature V+		N/A		1000	
HSFPU Opt. Bench temperature V-		N/A		1000	
HSFPU Opt. Bench temperature I-		1 $\mu$ A		1000	
HSFPU Opt. Bench temperature shld*B		N/A		N/A	
Spectrometer 2K box temperature I+		1 $\mu$ A	Insulated screened twisted quad	1000	
Spectrometer 2K box temperature V+		N/A		1000	
Spectrometer 2K box temperature V-		N/A		1000	
Spectrometer 2K box temperature I-		1 $\mu$ A		1000	
Spectrometer 2K box temperature shld*		N/A		N/A	
Photometer 2K box temperature I+		1 $\mu$ A	Insulated screened twisted quad	1000	
Photometer 2K box temperature V+		N/A		1000	
Photometer 2K box temperature V-		N/A		1000	
Photometer 2K box temperature I-		1 $\mu$ A		1000	
Photometer 2K box temperature shld*		N/A		N/A	
M3,5,7 Optical SubBench temperature I+		1 $\mu$ A	Insulated screened twisted quad	1000	
M3,5,7 Optical SubBench temperature V+		N/A		1000	
M3,5,7 Optical SubBench temperature V-		N/A		1000	
M3,5,7 Optical SubBench temperature I-		1 $\mu$ A		1000	
M3,5,7 Optical SubBench temperature shld*		N/A		N/A	
HSFPU Input Baffle temperature I+		1 $\mu$ A	Insulated screened twisted quad	1000	
HSFPU Input Baffle temperature V+		N/A		1000	
HSFPU Input Baffle temperature V-		N/A		1000	
HSFPU Input Baffle temperature I-		1 $\mu$ A		1000	
HSFPU Input Baffle temperature shld*		N/A		N/A	
BSM/SOB I/F temperature I+		1 $\mu$ A	Insulated screened twisted quad	1000	
BSM/SOB I/F temperature V+		N/A		1000	
BSM/SOB I/F temperature V-		N/A		1000	
BSM/SOB I/F temperature I-		1 $\mu$ A		1000	
BSM/SOB I/F temperature shld*		N/A		N/A	
HS Spect. Stimulus Flange temperature I+		1 $\mu$ A	Insulated screened twisted quad	1000	
HS Spect. Stimulus Flange temperature V+		N/A		1000	
HS Spect. Stimulus Flange temperature V-		N/A		1000	
HS Spect. Stimulus Flange temperature I-		1 $\mu$ A		1000	
HS Spect. Stimulus Flange temperature shld*		N/A		N/A	
Thermal Control Heater I+_A		2mA	Insulated screened twisted quad	100	
Thermal Control Heater I+_B		2 mA		100	
Thermal Control Heater I-_A		2 mA		100	
Thermal Control Heater I-_B		2 mA		100	
Thermal Control Heater shld.		N/A		N/A	

32 ways + 2 shields used



# SPIRE HARNESS DEFINITION

Doc #: SPIRE-RAL-PRJ-000608  
Issue: 0.7  
Date: 19/09/01  
Page 47 of 136

## FPU Thermometry Listing B J25

Function	37way J25	Max. current	Wire lay-up	Max Ohms	100way #10
Sorption Pump temperature I+		1 $\mu$ A	Insulated screened twisted quad	1000	
Sorption Pump temperature V+		N/A		1000	
Sorption Pump temperature V-		N/A		1000	
Sorption Pump temperature I-		1 $\mu$ A		1000	
Sorption Pump temperature shld*		N/A		N/A	
Evaporator temperature I+		1 $\mu$ A	Insulated screened twisted quad	1000	
Evaporator temperature V+		N/A		1000	
Evaporator temperature V-		N/A		1000	
Evaporator temperature I-		1 $\mu$ A		1000	
Evaporator temperature shld*		N/A		N/A	
Sorption Pump Heat Switch temperature I+		1 $\mu$ A	Insulated screened twisted quad	1000	
Sorption Pump Heat Switch temperature V+		N/A		1000	
Sorption Pump Heat Switch temperature V-		N/A		1000	
Sorption Pump Heat Switch temperature I-		1 $\mu$ A		1000	
Sorption Pump Heat Switch temperature shld*		N/A		N/A	
Evaporator Heat Switch temperature I+		1 $\mu$ A	Insulated screened twisted quad	1000	
Evaporator Heat Switch temperature V+		N/A		1000	
Evaporator Heat Switch temperature V-		N/A		1000	
Evaporator Heat Switch temperature I-		1 $\mu$ A		1000	
Evaporator Heat Switch temperature shld*		N/A		N/A	
Thermal Shunt temperature I+ _A		1 $\mu$ A	Insulated screened twisted quad	1000	
Thermal Shunt temperature V+ _B		N/A		1000	
Thermal Shunt temperature V- _A		N/A		1000	
Thermal Shunt temperature I- _B		1 $\mu$ A		1000	
Thermal Shunt temperature shld*		N/A		N/A	
HS Spect. 4% temperature I+		1 $\mu$ A	Insulated screened twisted quad	1000	
HS Spect. 4% temperature V+		N/A		1000	
HS Spect. 4% temperature V-		N/A		1000	
HS Spect. 4% temperature I-		1 $\mu$ A		1000	
HS Spect. 4% temperature shld*		N/A		N/A	
HS Spect. 2% temperature I+		1 $\mu$ A	Insulated screened twisted quad	1000	
HS Spect. 2% temperature V+		N/A		1000	
HS Spect. 2% temperature V-		N/A		1000	
HS Spect. 2% temperature I-		1 $\mu$ A		1000	
HS Spect. 2% temperature shld*		N/A		N/A	

\* = linked on 100 way.

28 ways + 1 ground shield in use out of 37 ways.

Total number of contacts in use = 15 +12+ 8 +34 +29 + harness shield link = 99 contacts.



# SPIRE HARNESS DEFINITION

Doc #: SPIRE-RAL-PRJ-000608  
Issue: 0.7  
Date: 19/09/01  
Page 48 of 136

## 4.2.11 I11 HSDCU to CVV11 DRV-P

### Overall Mechanical Drwg.

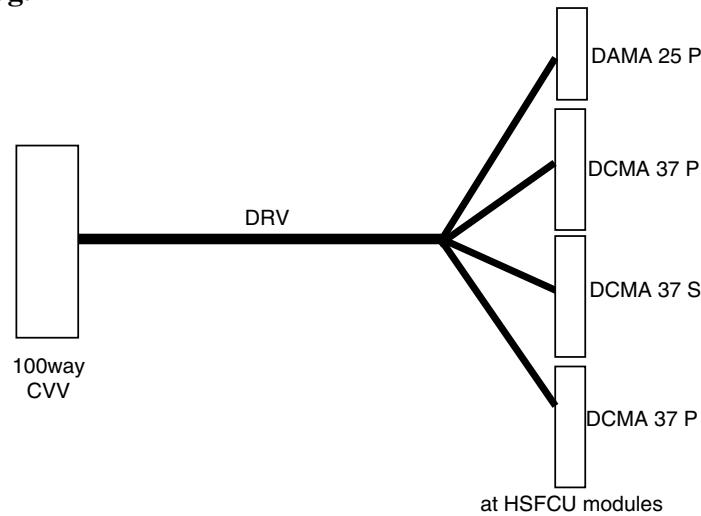

### Connector/Backshell Details

Redundant side harness

DBMA 25 P + XXXX: interface to HSFCU J21 Temperatures

DCMA 37P+ XXXX: interface to HSFCU J17 SMEC Control

DCMA 37S+ XXXX: interface to HSFCU J29 SMEC Launch

DCMA 37 P + XXXX: interface to HSFCU J19 BSM

### Harness Layups

As per tail listings.

### Temperature Tail Listing J21

Function	25way J21	Max. current	Wire lay-up	Max Ohms	100way #11
BSM temperature I+	1	1 $\mu$ A	Insulated screened twisted quad	1000	
BSM temperature V+	14	N/A		1000	
BSM temperature V-	15	N/A		1000	
BSM temperature I-	2	1 $\mu$ A		1000	
BSM temperature shld	3	N/A		N/A	
SMEC temperature I+	4	1 $\mu$ A	Insulated screened twisted quad	1000	
SMEC temperature V+	17	N/A		1000	
SMEC temperature V-	18	N/A		1000	
SMEC temperature I-	5	1 $\mu$ A		1000	
SMEC temperature shld	16	N/A		N/A	
SMEC/SOB I/F temperature I+	6	1 $\mu$ A	Insulated screened twisted quad	1000	
SMEC/SOB I/F temperature V+	19	N/A		1000	
SMEC/SOB I/F temperature V-	20	N/A		1000	
SMEC/SOB I/F temperature I-	7	1 $\mu$ A		1000	
SMEC/SOB I/F temperature shld	8	N/A		N/A	
Photometer Point Stim. heater I+ _A	11	7 mA	twisted quad	10	
Photometer Point Stim.heater I+ _B	23	7 mA		10	
Photometer Point Stim.heater I- _A	12	7 mA		10	
Photometer Point Stim.heater I- _B	24	7 mA		10	

19 contacts used.





# SPIRE HARNESS DEFINITION

Doc #: SPIRE-RAL-PRJ-000608  
 Issue: 0.7  
 Date: 19/09/01  
 Page 49 of 136

## SMEC Control Tail Listing

Function	37way J17	Max. current	Wire lay-up	Max Ohms	100way #11
SMEC Drive Coil I+	1	100mA	Insulated screened twisted pair	5	
SMEC Drive Coil I-	2	100mA		5	
SMEC Drive Coil shld	20	N/A		N/A	A
SMEC Drive Coil (Rob) I+	21	100mA	Insulated screened twisted pair	5	
SMEC Drive Coil (Rob) I-	22	100mA		5	
SMEC Drive Coil (Rob) shld	3	N/A		N/A	A
SMEC Drive Coil Sense+	4	10 $\mu$ A	Insulated screened twisted pair	500	
SMEC Drive Coil Sense-	5	10 $\mu$ A		500	
SMEC Drive Coil shld	23	N/A		N/A	
SMEC position sensor Led power supply	7	1mA	Insulated screened twisted pair	100	
SMEC position sensor Led power return	8	1mA		100	
SMEC position sensor Led power Shield	26	N/A		N/A	
SMEC position sensor power supply	27	1mA	Insulated screened twisted pair	100	
SMEC position sensor power return	28	1mA		100	
SMEC position sensor power Shield	9	N/A		N/A	
SMEC position sensor photodiode #1 I+	10	20 $\mu$ A	Insulated screened twisted pair	1000	
SMEC position sensor photodiode #1 I-	11	20 $\mu$ A		1000	
SMEC position sensor photodiode Shield	29	N/A		N/A	B
SMEC pos. sensor photodiode #1 feedback +	30	10 $\mu$ A	Insulated screened twisted pair	1000	
SMEC pos. sensor photodiode #1 feedback -	31	10 $\mu$ A		1000	
SMEC pos. sensor photodiode feedback Shld	12	N/A		N/A	C
SMEC position sensor photodiode #2 I+	13	20 $\mu$ A	Insulated screened twisted pair	1000	
SMEC position sensor photodiode #2 I-	14	20 $\mu$ A		1000	
SMEC position sensor photodiode Shield	32	N/A		N/A	B
SMEC pos. sensor photodiode #2 feedback +	33	10 $\mu$ A	Insulated screened twisted pair	1000	
SMEC pos. sensor photodiode #2 feedback -	34	10 $\mu$ A		1000	
SMEC pos. sensor photodiode feedback Shld	15	N/A		N/A	C
SMEC position sensor photodiode #3 I+	16	20 $\mu$ A	Insulated screened twisted pair	1000	
SMEC position sensor photodiode #3 I-	17	20 $\mu$ A		1000	
SMEC position sensor photodiode Shield	35	N/A		N/A	B
SMEC pos. sensor photodiode #3 feedback +	36	10 $\mu$ A	Insulated screened twisted pair	1000	
SMEC pos. sensor photodiode #3 feedback -	37	10 $\mu$ A		1000	
SMEC pos. sensor photodiode feedback Shld	18	N/A		N/A	C

33(28) contacts in use.



# SPIRE HARNES DEFINITION

Doc #: SPIRE-RAL-PRJ-000608  
 Issue: 0.7  
 Date: 19/09/01  
 Page 50 of 136

## SMEC Launch Tail Listing

Function	37way J29	Max. current	Wire lay-up	Max Ohms	100way #11
SMEC launch latch # 1 confirmation +	1	1 mA	Insulated screened twisted pair	5	
SMEC launch latch # 1 confirmation -	20	1 mA		5	
SMEC launch latch # 1 confirmation Shield	3	N/A		N/A	A [noisy SVM]
SMEC launch latch # 2 confirmation + TBC	2	1 mA	Insulated screened twisted pair	5	
SMEC launch latch # 2 confirmation - TBC	21	1 mA		5	
SMEC launch latch # 2 confirmation Shld TBC	3	N/A		N/A	A[noisy SVM]
SMEC launch latch #1 power supply_1	21	400 mA / 50ms	Insulated screened twisted pair	5	
SMEC launch latch #1 power return_1	22	400 mA / 50ms		5	
SMEC launch latch #1 power Shield_1	4	N/A		N/A	B
SMEC launch latch #1 power supply_2	5	400 mA / 50ms	Insulated screened twisted pair	5	
SMEC launch latch #1 power return_2	6	400 mA / 50ms		5	
SMEC launch latch #1 power Shield_2	23	N/A		N/A	B
SMEC launch latch #2 power supply_1	24	400 mA / 50ms	Insulated screened twisted pair	5	
SMEC launch latch #2 power return_1	25	400 mA / 50ms		5	
SMEC launch latch #2 power Shield_1	7	N/A		N/A	B
SMEC launch latch #2 power supply_2 TBC	8	400 mA / 50ms	Insulated screened twisted pair	5	
SMEC launch latch #2 power return_2 TBC	9	400 mA / 50ms		5	
SMEC launch latch #2 power Shield_2 TBC	26	N/A		N/A	B
SMEC LVDT primary coil power supply (P)	32	5 mA	Insulated screened twisted pair	5	
SMEC LVDT primary coil power supply (N)	33	5 mA		5	
SMEC LVDT primary coil power supply Shld	15	N/A		N/A	D
SMEC LVDT secondary coil # 1 signal (P)	35	50 $\mu$ A	Insulated screened twisted pair	5	
SMEC LVDT secondary coil # 1 signal (N)	36	50 $\mu$ A		5	
SMEC LVDT secondary coil # 1 signal Shield	17	N/A		N/A	D
SMEC LVDT secondary coil # 2 signal (P)	18	50 $\mu$ A	Insulated screened twisted pair	5	
SMEC LVDT secondary coil # 2 signal (N)	19	50 $\mu$ A		5	
SMEC LVDT secondary coil # 2 signal Shield	37	N/A		N/A	D

27(21) contacts used



# SPIRE HARNESS DEFINITION

Doc #: SPIRE-RAL-PRJ-000608  
 Issue: 0.7  
 Date: 19/09/01  
 Page 51 of 136

## BSM Tail Listing

Function	37way J25	Max. current	Wire lay-up	Max Ohms	100way #11
Chop Position Sensor 1	1	1 $\mu$ A	Insulated screened twisted pair	1000	
Chop Position Sensor 2	20	N/A		1000	
Chop Position Sensor shld1	to A	N/A		N/A	linked
Chop Position Sensor 3	2	250 nA	Insulated screened twisted triple	1000	
Chop Position Sensor 4	21	N/A		1000	
Chop Position Sensor 5	3	N/A		1000	
Chop Position Sensor shld2=A	22	N/A		N/A	
Jiggle Position Sensor 1	4	1 $\mu$ A	Insulated screened twisted pair	1000	
Jiggle Position Sensor 2	23	N/A		1000	
Jiggle Position Sensor shld1	to B	N/A		N/A	linked
Jiggle Position Sensor 3	5	250 nA	Insulated screened twisted triple	1000	
Jiggle Position Sensor 4	24	N/A		1000	
Jiggle Position Sensor 5	6	N/A		1000	
Jiggle Position Sensor shld2=B	22	N/A		N/A	
BSM Launch latch confirmation 1	30	1mA	Insulated screened twisted pair	1000	
BSM Launch latch confirmation 2	12	1mA		1000	
Launch latch confirmation shld to platform gnd	31	N/A		N/A	
BSM Launch latch drive +	13	35mA	Insulated screened twisted triple	10	
BSM Launch latch drive -	32	35mA		10	
BSM Launch latch drive shld	33	N/A		N/A	
Chop Motor Drive 1	15	40 mA	Insulated screened twisted quad	10	
Chop Motor Drive 2	34	40 mA		10	
Chop Motor Drive 3	16	40 mA		10	
Chop Motor Drive 4	35	40 mA		10	
Chop Motor Drive shld	17	N/A		N/A	
Chop Motor Drive 1	36	40 mA	Insulated screened twisted quad	10	
Chop Motor Drive 2	18	40 mA		10	
Chop Motor Drive 3	37	40 mA		10	
Chop Motor Drive 4	19	40 mA		10	
Chop Motor Drive shld	17	N/A		N/A	linked

This 37way connector is has 30(27) ways populated.

Total number of contacts in use at 100way = 19+28+21+27=95.



# SPIRE HARNESS DEFINITION

Doc #: SPIRE-RAL-PRJ-000608  
Issue: 0.7  
Date: 19/09/01  
Page 52 of 136

## 4.2.12 I12 HSDCU to CVV12 AUX-R

### **Overall Mechanical Drwg.**

Redundant version of I10, and the same as it

### **Connector/Backshell Details**

Prime side harness

DAMA 15 P + XXXX: interface to HSFCU J16 Shutter

DAMA 15 P + XXXX: interface to HSFCU J12 Cooler

DMA 9 P + XXXX: interface to HSFCU J14 FTS Stimulus

DCMA 37 P + XXXX: interface to HSFCU J24 Temperature sensors

DCMA 37 P + XXXX: interface to HSFCU J26 Temperature sensors

### **Harness Layup**

As I10



# SPIRE HARNES DEFINITION

Doc #: SPIRE-RAL-PRJ-000608  
Issue: 0.7  
Date: 19/09/01  
Page 53 of 136

## 4.2.13 I13 HSDCU to CVV13 DRV-R

### Overall Mechanical Drwg.

Format as I11, maybe differing lengths.

### Connector/Backshell Details

Redundant side harness

DBMA 25 P + XXXX: interface to HSFCU J22 Temperatures

DCMA 37P+ XXXX: interface to HSFCU J18 SMEC Control

DCMA 37S+ XXXX: interface to HSFCU J30 SMEC Launch

DCMA 37 P + XXXX: interface to HSFCU J20 BSM

### Harness Layup

As I11.

### Contact Details

As I11



# SPIRE HARNESS DEFINITION

Doc #: SPIRE-RAL-PRJ-000608  
Issue: 0.7  
Date: 19/09/01  
Page 54 of 136

## 4.3 Cryogenic Harnesses

### 4.3.1 C1 CVV1 to HSJFS Type3

#### Overall Mechanical Drwg.

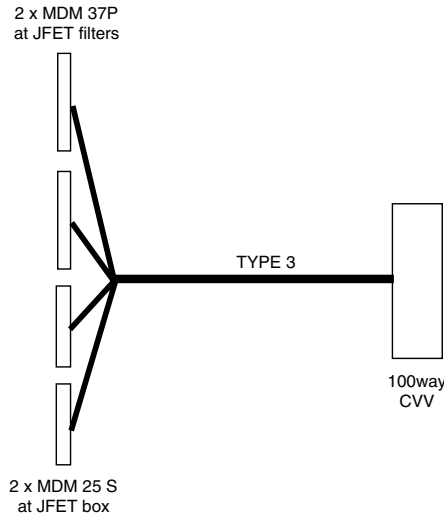

#### Connector/Backshell Details:

MDM 25 S + XXXX: interface to HSJFS J5  
MDM 25 S + XXXX: interface to HSJFS J6  
MDM 37 P + XXXX: interface to HSJFS J9 bias A  
MDM 37 P + XXXX: interface to HSJFS J10 bias B

#### Harness Layup

Two 25way JFET bolometer tails, each as those in C4.  
Two 37 way Spectrometer JFET Filter tails, each as follows:

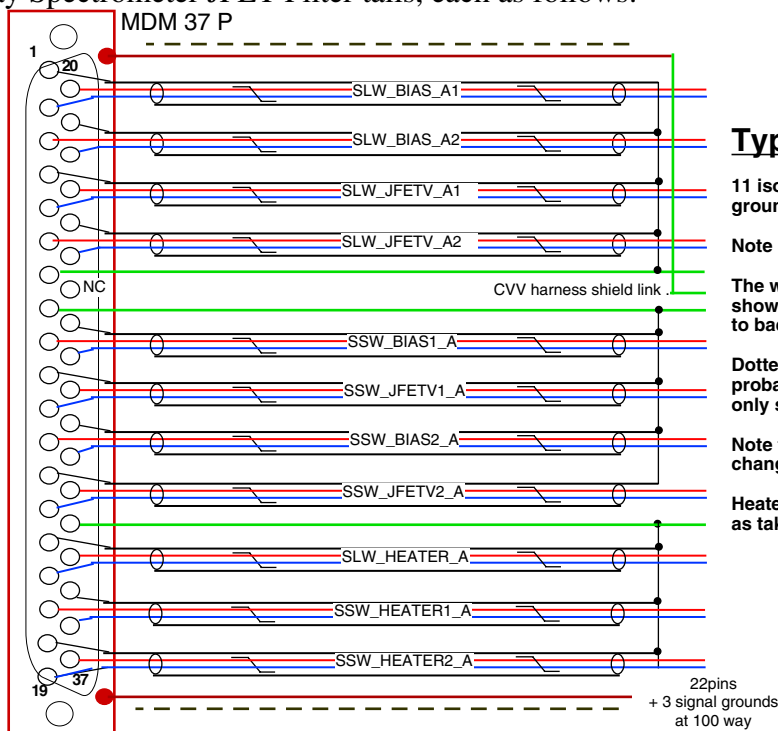

#### Type 3 Bias Filters

11 isolated screened twisted pairs + 3 ground single wires.

Note SLW and SSW ground separation.

The whole overlain with RF screen shown: **NOT** joined to backshell CVV end.

Dotted lines show insulation, probably put around bundles but only strictly needed at clamp points.

Note that for the other Bias tail change the last A in each name to B

Heaters parallel wires shown single. OK as takes same current as JFET supplies.

Because the small SLW has no subgroups that might fail, EACH of the JFET bachharness leads is double-wired in this cryoharness, requiring linked across in the filters.

#### Contact details



# SPIRE HARNES DEFINITION

Doc #: SPIRE-RAL-PRJ-000608  
 Issue: 0.7  
 Date: 19/09/01  
 Page 55 of 136

Name	25way A J5	25wayB J6	37way C J9	37way D J10	100Way #1
Channel 1 +	1				TBD
Channel 1 -	14				TBD
Channel 1gnd shld	NC				XXX
Channel 2 +	2				TBD
Channel 2 -	15				TBD
Channel 2gnd shld	NC				XXX
Channel 3 +	3				TBD
Channel 3 -	16				TBD
Channel 3gnd shld	NC				XXX
Channel 4 +	4				TBD
Channel 4 -	17				TBD
Channel 4gnd shld	NC				XXX
Channel 5 +	5				TBD
Channel 5 -	18				TBD
Channel 5gnd shld	NC				XXX
Channel 6 +	6				TBD
Channel 6 -	19				TBD
Channel 6gnd shld	NC				XXX
Channel 7 +	20				TBD
Channel 7 -	7				TBD
Channel 7gnd shld	NC				XXX
Channel 8 +	21				TBD
Channel 8 -	8				TBD
Channel 8gnd shld	NC				XXX
Channel 9 +	22				TBD
Channel 9 -	9				TBD
Channel 9gnd shld	NC				XXX
Channel 10 +	23				TBD
Channel 10 -	10				TBD
Channel 10gnd shld	NC				XXX
Channel 11 +	24				TBD
Channel 11 -	11				TBD
Channel 11gnd shld	NC				XXX
Channel 12 +	25				TBD
Channel 12 -	12				TBD
Channel 12gnd shld	NC				TBD
SSW GND WIRE	13				XXX
Channel 13 +		1			TBD
Channel 13 -		14			TBD
Channel 1gnd shld		NC			XXX
Channel 14 +		2			TBD
Channel 14 -		15			TBD
Channel 1gnd shld		NC			XXX
Channel 15 +		3			TBD
Channel 15 -		16			TBD
Channel 15gnd shld		NC			XXX
Channel 16 +		4			TBD
Channel 16 -		17			TBD
Channel 16gnd shld		NC			XXX
Channel 17 +		5			TBD
Channel 17 -		18			TBD
Channel 17gnd shld		NC			XXX
Channel 18 +		6			TBD
Channel 18 -		19			TBD
Channel 18gnd shld		NC			XXX
Channel 19 +		20			TBD
Channel 19 -		7			TBD



# SPIRE HARNES DEFINITION

Doc #: SPIRE-RAL-PRJ-000608  
 Issue: 0.7  
 Date: 19/09/01  
 Page 56 of 136

Name	25way A J5	25wayB J6	37way C J9	37way D J10	100Way #1
Channel 19gnd shld		NC			XXX
Channel 20 +		21			TBD
Channel 20 -		8			TBD
Channel 1gnd shld		NC			XXX
Channel 21 +		22			TBD
Channel 21 -		9			TBD
Channel 21gnd shld		NC			XXX
Channel 22 +		23			TBD
Channel 22 -		10			TBD
Channel 22gnd shld		NC			XXX
Channel 23 +		24			TBD
Channel 23 -		11			TBD
Channel 23gnd shld		NC			XXX
Channel 24 +		25			TBD
Channel 24 -		12			TBD
Channel 24gnd shld		NC			TBD
SSW GND WIRE		13			XXX
SLW_BIAS_A1+ve			20		TBD
SLW_BIAS_A1-ve			2		TBD
SLW_BIAS_A1 shld			1		XXX
SLW_BIAS_A2 +ve			3		TBD
SLW_BIAS_A2 -ve			22		TBD
SLW_BIAS_A2 shld			21		XXX
SLW_JFETV_A1 +ve			23		TBD
SLW_JFETV_A1 -ve			5		TBD
SLW_JFETV_A1 shld			4		XXX
SLW_JFETV_A2 +ve			6		TBD
SLW_JFETV_A2 -ve			25		TBD
SLW_JFETV_A2 shld			24		XXX
SLW_GND_WIRE_A			7		TBD
Harness shield Link			N/C		Yes
SSW_GND_WIRE_A			8		TBD
SSW_BIAS1_A +ve			9		TBD
SSW_BIAS1_A -ve			28		TBD
SSW_BIAS1_A shld			27		XXX
SSW_JFETV1_A +ve			29		TBD
SSW_JFETV1_A -ve			11		TBD
SSW_JFETV1_A shld			10		XXX
SSW_BIAS2_A +ve			12		TBD
SSW_BIAS2_A -ve			31		TBD
SSW_BIAS2_A shld			30		XXX
SSW_JFETV2_A +ve			32		TBD
SSW_JFETV2_A -ve			14		TBD
SSW_JFETV2_A shld			13		XXX
S_HEATER_GROUND_WIRE_A			33		TBD
SLW_HEATER_A +ve			34		TBD
SLW_HEATER_A -ve			16		TBD
SLW_HEATER_A shld			15		XXX
SSW_HEATER1_A +ve			17		TBD
SSW_HEATER1_A -ve			36		TBD
SSW_HEATER1_A shld			35		XXX
SSW_HEATER2_A +ve			37		TBD
SSW_HEATER2_A -ve			19		TBD
SSW_HEATER2_A shld			18		XXX
SLW_BIAS_B1+ve				20	TBD
SLW_BIAS_B1-ve				2	TBD
SLW_BIAS_B1 shld				1	XXX





# SPIRE HARNES DEFINITION

Doc #: SPIRE-RAL-PRJ-000608  
 Issue: 0.7  
 Date: 19/09/01  
 Page 57 of 136

Name	25way A J5	25wayB J6	37way C J9	37way D J10	100Way #1
SLW_BIAS_B2 +ve				3	TBD
SLW_BIAS_B2 -ve				22	TBD
SLW_BIAS_B2 shld				21	XXX
SLW_JFETV_B1 +ve				23	TBD
SLW_JFETV_B1 -ve				5	TBD
SLW_JFETV_B1 shld				4	XXX
SLW_JFETV_B2 +ve				6	TBD
SLW_JFETV_B2 -ve				25	TBD
SLW_JFETV_B2 shld				24	XXX
SLW_GND WIRE_B				7	TBD
Harness shield link				N/C	Yes
SSW_GND WIRE_B				8	TBD
SSW_BIAS1_B +ve				9	TBD
SSW_BIAS1_B -ve				28	TBD
SSW_BIAS1_B shld				27	XXX
SSW_JFETV1_B +ve				29	TBD
SSW_JFETV1_B -ve				11	TBD
SSW_JFETV1_B shld				10	XXX
SSW_BIAS2_B +ve				12	TBD
SSW_BIAS2_B -ve				31	TBD
SSW_BIAS2_B shld				30	XXX
SSW_JFETV2_B +ve				32	TBD
SSW_JFETV2_B -ve				14	TBD
SSW_JFETV2_B shld				13	XXX
S_HEATER GROUND WIRE_B				33	TBD
SLW_HEATER_B +ve				34	TBD
SLW_HEATER_B -ve				16	TBD
SLW_HEATER_B shld				15	XXX
SSW_HEATER1_B +ve				17	TBD
SSW_HEATER1_B -ve				36	TBD
SSW_HEATER1_B shld				35	XXX
SSW_HEATER2_B +ve				37	TBD
SSW_HEATER2_B -ve				19	TBD
SSW_HEATER2_B shld				18	XXX



# SPIRE HARNES DEFINITION

Doc #: SPIRE-RAL-PRJ-000608  
Issue: 0.7  
Date: 19/09/01  
Page 58 of 136

## 4.3.2 C2 CVV2 to HSJFS Type4

Overall Mechanical Drwg.

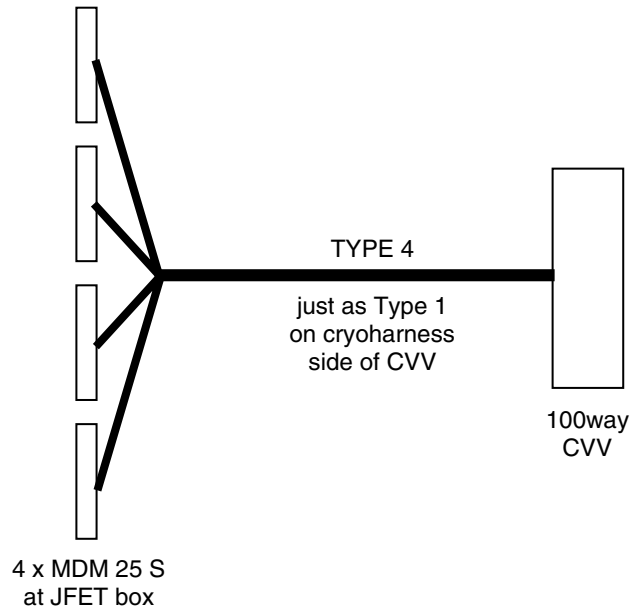

### Connector/Backshell Details

MDM 25 S +xxxx: interface to HSJFS J1  
MDM 25 S +xxxx: interface to HSJFS J2  
MDM 25 S +xxxx: interface to HSJFS J3  
MDM 25 S +xxxx: interface to HSJFS J4

### Harness Layup

4 JFET bolometer tails as in C4, Type 1.



# SPIRE HARNES DEFINITION

Doc #: SPIRE-RAL-PRJ-000608  
Issue: 0.7  
Date: 19/09/01  
Page 59 of 136

## 4.3.3 C3 CVV3 to HSJFP Type2

### Overall Mechanical Drwg.

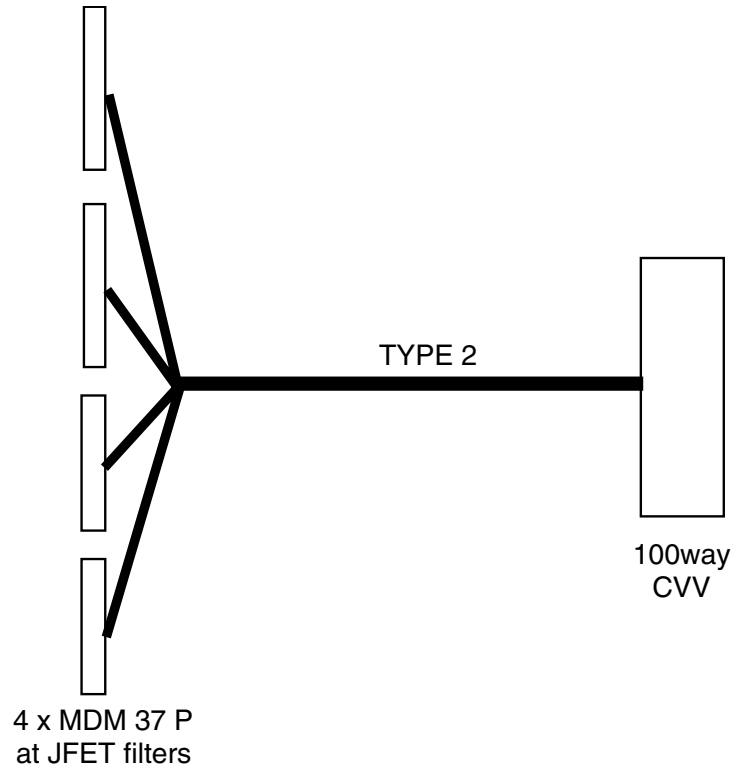

### Connector/Backshell Details

MDM 37 P +xxxx: interface to HSJFP J25  
MDM 37 P +xxxx: interface to HSJFP J27  
MDM 37 P +xxxx: interface to HSJFP J26  
MDM 37 P +xxxx: interface to HSJFP J28



# SPIRE HARNES DEFINITION

Doc #: SPIRE-RAL-PRJ-000608  
Issue: 0.7  
Date: 19/09/01  
Page 60 of 136

## Harness Layup

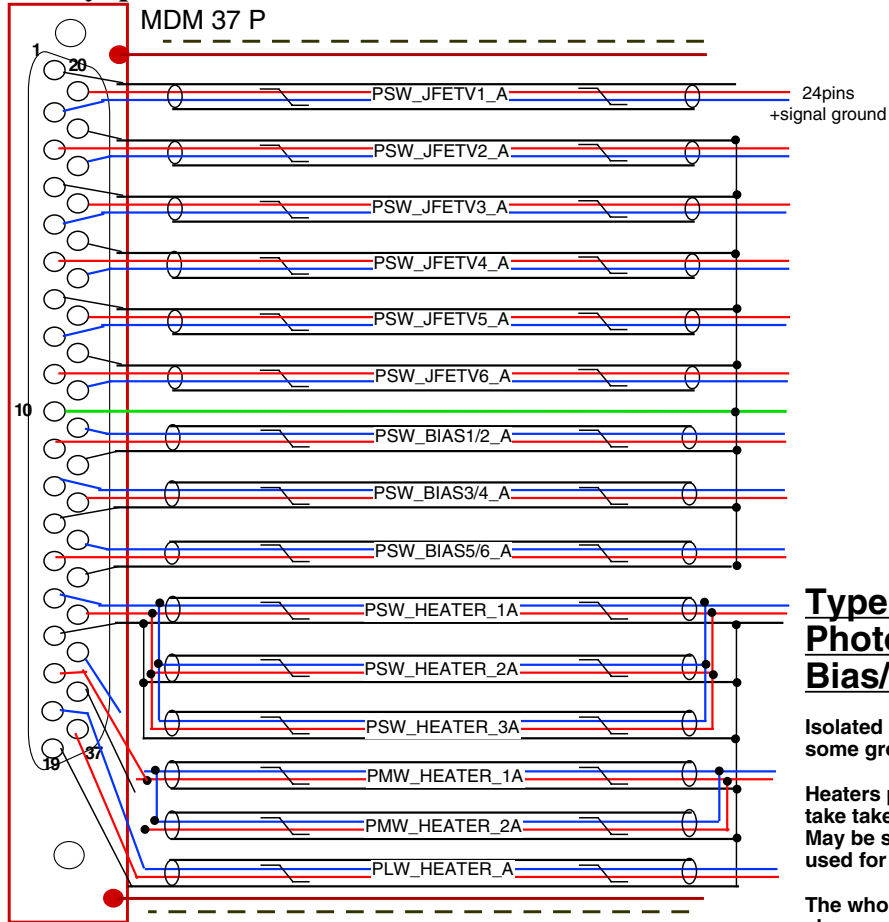

### Type 2 ....A Side Photometer Bias/Supply Filters

Isolated screened twisted pairs with some ground singlr wires.

Heaters parallel wired because assumed take takes same current as JFET supplies. May be simplified if heavier gauge can be used for heater wires.

The whole overlain with RF screen shown:        NOT joined to backshell CVV end.

Dotted lines show insulation, probably put around bundles but only strictly needed at clamp points.

Note that for the other Bias tails change the last A in each name to B

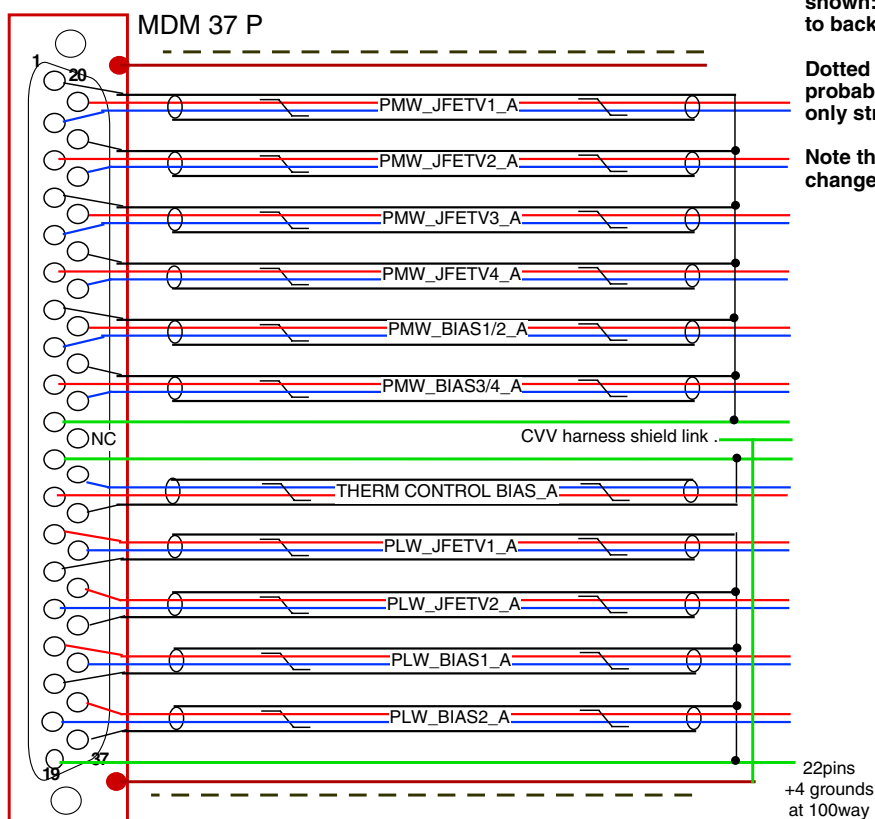



# SPIRE HARNES DEFINITION

Doc #: SPIRE-RAL-PRJ-000608  
 Issue: 0.7  
 Date: 19/09/01  
 Page 61 of 136

## Contact Details

Name	37way J25	37way J27	37Way J26	37way J28	100Way #3
PSW_JFETV1_A +	20				
PSW_JFETV1_A -	2				
PSW_JFETV1_A shld	1				
PSW_JFETV2_A +	3				
PSW_JFETV2_A -	22				
PSW_JFETV2_A shld	21				
PSW_JFETV3_A +	23				
PSW_JFETV3_A -	4				
PSW_JFETV3_A shld	5				
PSW_JFETV4_A +	6				
PSW_JFETV4_A -	25				
PSW_JFETV4_A shld	24				
PSW_JFETV5_A +	26				
PSW_JFETV5_A -	8				
PSW_JFETV5_A shld	7				
PSW_JFETV6_A +	9				
PSW_JFETV6_A -	28				
PSW_JFETV6_A shld	27				
PSW_GRND_A	10				
PSW_BIAS1/2_A +	11				
PSW_BIAS1/2_A -	29				
PSW_BIAS1/2_A shld	30				
PSW_BIAS3/4_A +	31				
PSW_BIAS3/4_A -	12				
PSW_BIAS3/4_A shld	13				
PSW_BIAS5/6_A +	14				
PSW_BIAS5/6_A -	32				
PSW_BIAS5/6_A shld	33				
PSW_HEATER_A +x3	34				
PSW_HEATER_A -x3	15				
PSW_HEATER_A shldx3	16				
PMW_HEATER_A +x2	17				
PMW_HEATER_A -x2	35				
PMW_HEATER_A shldx2	36				
PLW_HEATER_A +	37				
PLW_HEATER_A-	18				
PLW_HEATER_A shld	19				
PMW_JFETV1_A +		20			
PMW_JFETV1_A -		2			
PMW_JFETV1_A shld		1			
PMW_JFETV2_A +		3			
PMW_JFETV2_A -		22			
PMW_JFETV2_A shld		21			
PMW_JFETV3_A +		23			
PMW_JFETV3_A -		5			
PMW_JFETV3_A shld		4			
PMW_JFETV4_A +		6			
PMW_JFETV4_A -		25			
PMW_JFETV4_A shld		24			
PMW_BIAS1/2_A +		26			
PMW_BIAS1/2_A -		8			
PMW_BIAS1/2_A shld		7			
PMW_BIAS3/4_A +		9			
PMW_BIAS3/4_A -		28			
PMW_BIAS3/4_A shld		27			
PMW_GND WIRE_A		10			



# SPIRE HARNES DEFINITION

Doc #: SPIRE-RAL-PRJ-000608  
 Issue: 0.7  
 Date: 19/09/01  
 Page 62 of 136

Name	37way J25	37way J27	37Way J26	37way J28	100Way #3
Harness Shield Link		NC			Yes
THERM GND WIRE_A		11			
THERM CONTROL BIAS_A +		12			
THERM CONTROL BIAS_A -		30			
THERM CONTROL BIAS_A shld.		31			
PLW_JFETV1_A +		13			
PLW_JFETV1_A -		32			
PLW_JFETV1_A shld		15			
PLW_JFETV2_A +		33			
PLW_JFETV2_A -		15			
PLW_JFETV2_A shld		34			
PLW_BIAS1_A +		16			
PLW_BIAS1_A -		36			
PLW_BIAS1_A shld		17			
PLW_BIAS2_A +		37			
PLW_BIAS2_A -		18			
PLW_BIAS2_A shld		37			
PLW_A GND WIRE		19			
PSW_JFETV1_B +			20		
PSW_JFETV1_B -			2		
PSW_JFETV1_B shld			1		
PSW_JFETV2_B +			3		
PSW_JFETV2_B -			22		
PSW_JFETV2_B shld			21		
PSW_JFETV3_B +			23		
PSW_JFETV3_B -			4		
PSW_JFETV3_B shld			5		
PSW_JFETV4_B +			6		
PSW_JFETV4_B -			25		
PSW_JFETV4_B shld			24		
PSW_JFETV5_B +			26		
PSW_JFETV5_B -			8		
PSW_JFETV5_B shld			7		
PSW_JFETV6_B +			9		
PSW_JFETV6_B -			28		
PSW_JFETV6_B shld			27		
PSW_GRND_B			10		
PSW_BIAS1/2_B +			11		
PSW_BIAS1/2_B -			29		
PSW_BIAS1/2_B shld			30		
PSW_BIAS3/4_B +			31		
PSW_BIAS3/4_B -			12		
PSW_BIAS3/4_B shld			13		
PSW_BIAS5/6_B +			14		
PSW_BIAS5/6_B -			32		
PSW_BIAS5/6_B shld			33		
PSW_HEATER_B +x3			34		
PSW_HEATER_B -x3			15		
PSW_HEATER_B shldx3			16		
PMW_HEATER_B +x2			17		
PMW_HEATER_B -x2			35		
PMW_HEATER_B shldx2			36		
PLW_HEATER_B +			37		
PLW_HEATER_B-			18		
PLW_HEATER_B shld			19		
PMW_JFETV1_B +				20	
PMW_JFETV1_B -				2	
PMW_JFETV1_B shld				1	



# SPIRE HARNES DEFINITION

Doc #: SPIRE-RAL-PRJ-000608  
 Issue: 0.7  
 Date: 19/09/01  
 Page 63 of 136

Name	37way J25	37way J27	37Way J26	37way J28	100Way #3
PMW_JFETV2_B +				3	
PMW_JFETV2_B -				22	
PMW_JFETV2_B shld				21	
PMW_JFETV3_B +				23	
PMW_JFETV3_B -				5	
PMW_JFETV3_B shld				4	
PMW_JFETV4_B +				6	
PMW_JFETV4_B -				25	
PMW_JFETV4_B shld				24	
PMW_BIAS1/2_B +				26	
PMW_BIAS1/2_B -				8	
PMW_BIAS1/2_B shld				7	
PMW_BIAS3/4_B +				9	
PMW_BIAS3/4_B -				28	
PMW_BIAS3/4_B shld				27	
PMW_GND_B				10	
Shield Link Wire				N/C	Yes
Therm GND_B				11	
THERM CONTROL BIAS_B +				12	
THERM CONTROL BIAS_B -				30	
THERM CONTROL BIAS_B shld.				31	
PLW_JFETV1_B +				13	
PLW_JFETV1_B -				32	
PLW_JFETV1_B shld				15	
PLW_JFETV2_B +				33	
PLW_JFETV2_B -				15	
PLW_JFETV2_B shld				34	
PLW_BIAS1_B +				16	
PLW_BIAS1_B -				36	
PLW_BIAS1_B shld				17	
PLW_BIAS2_B +				37	
PLW_BIAS2_B -				18	
PLW_BIAS2_B shld				37	
PLW_B GND WIRE				19	



# SPIRE HARNESS DEFINITION

Doc #: SPIRE-RAL-PRJ-000608  
Issue: 0.7  
Date: 19/09/01  
Page 64 of 136

## 4.3.4 C4 CVV4 to HSJFP Type1

### Overall Mechanical Drwg.

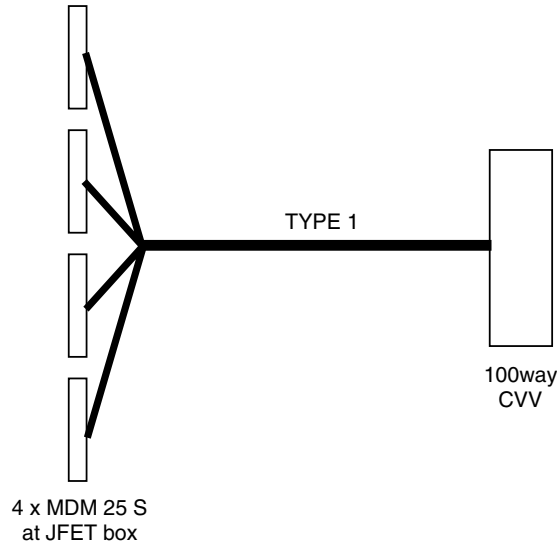

### Connector/Backshell Details

MDM 25 S +xxxx: interface to HSJFP11 J21  
MDM 25 S +xxxx: interface to HSJFP11 J22  
MDM 25 S +xxxx: interface to HSJFP12 J23  
MDM 25 S +xxxx: interface to HSJFP12 J24

### Harness Layup

The total harness layup is as follows:

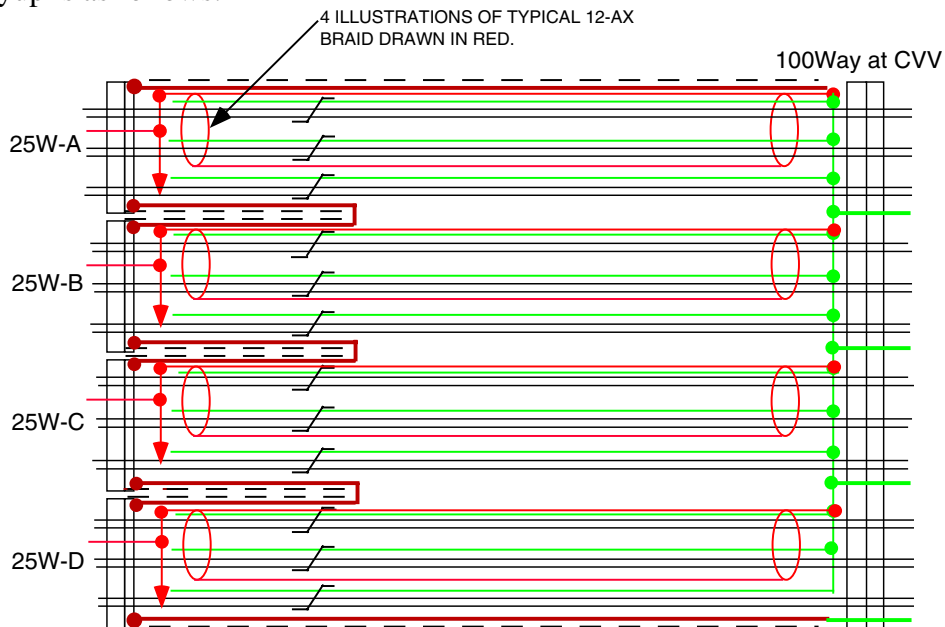

*There are 48 channels each carried as a twisted triple, grouped in fours as "12-ax", each with its own insulated screen. So there are 12 x 12-ax in all with three 12-ax to each 25 way MDM. The use of a third wire twisted with each channel's + & - signal wires minimises interchannel cross-talk inside each 12-ax.*

*As for the intermediate harness, 4 pins carry ground through the 100 way and carry an isolated ground ring. All the third wires are made off to this, as are all the 12-ax screens.*

*At the 25way MDMs, the three 12-ax braids (which have a much higher conductivity than that of the sum of all the third twisted wires) are joined to the third wires and passed through the one non-signal pin..*

*To keep RF screening distinct from low noisr bolometer grounds, all of this harness is enclosed in separate outer r.f. screen, EMC sealed to connector boots at the JFET end, overwrapped with insulation, and carried on a pin at the 100 way.*

Any one MDM tail, as drawn for the other harnesses, looks like:-





# SPIRE HARNESS DEFINITION

Doc #: SPIRE-RAL-PRJ-000608  
Issue: 0.7  
Date: 19/09/01  
Page 65 of 136

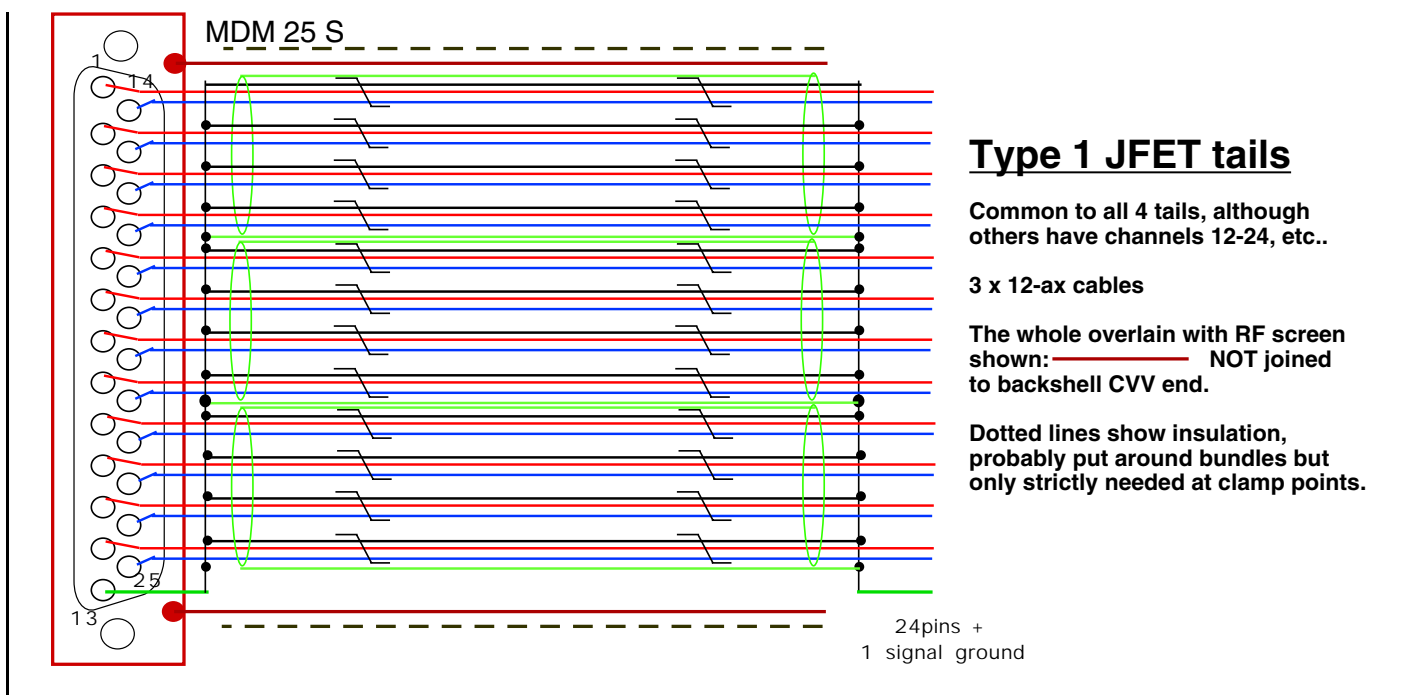

**Contact Details....this assumes JPL re-pin PCB connectors, see note at end.**

Note the contacts are named as "channels 1-48" end-end, and mapping to specific detector position is only maintained internal to the instrument.

Name	25way A	25wayB	25Way C	25way D	100Way #4
Channel 1 +	1				TBD
Channel 1 -	14				TBD
Channel 1gnd	NC				XXX
Channel 2 +	2				TBD
Channel 2 -	15				TBD
Channel 2gnd	NC				XXX
Channel 3 +	3				TBD
Channel 3 -	16				TBD
Channel 3gnd	NC				XXX
Channel 4 +	4				TBD
Channel 4 -	17				TBD
Channel 4gnd	NC				XXX
Channel 5 +	5				TBD
Channel 5 -	18				TBD
Channel 5gnd	NC				XXX
Channel 6 +	6				TBD
Channel 6 -	19				TBD
Channel 6gnd	NC				XXX
Channel 7 +	20				TBD
Channel 7 -	7				TBD
Channel 7gnd	NC				XXX
Channel 8 +	21				TBD
Channel 8 -	8				TBD
Channel 8gnd	NC				XXX
Channel 9 +	22				TBD
Channel 9 -	9				TBD
Channel 9gnd	NC				XXX
Channel 10 +	23				TBD
Channel 10 -	10				TBD
Channel 10gnd	NC				XXX
Channel 11 +	24				TBD
Channel 11 -	11				TBD
Channel 11gnd	NC				XXX
Channel 12 +	25				TBD
Channel 12 -	12				TBD



# SPIRE HARNES DEFINITION

Doc #: SPIRE-RAL-PRJ-000608

Issue: 0.7

Date: 19/09/01

Page 66 of 136

Name	25way A	25wayB	25Way C	25way D	100Way #4
Channel 12gnd	NC				TBD
GND WIRE	13				XXX
Channel 13 +		1			TBD
Channel 13 -		14			TBD
Channel 1gnd		NC			XXX
Channel 14 +		2			TBD
Channel 14 -		15			TBD
Channel 1gnd		NC			XXX
Channel 15 +		3			TBD
Channel 15 -		16			TBD
Channel 15gnd		NC			XXX
Channel 16 +		4			TBD
Channel 16 -		17			TBD
Channel 16gnd		NC			XXX
Channel 17 +		5			TBD
Channel 17 -		18			TBD
Channel 17gnd		NC			XXX
Channel 18 +		6			TBD
Channel 18 -		19			TBD
Channel 18gnd		NC			XXX
Channel 19 +		20			TBD
Channel 19 -		7			TBD
Channel 19gnd		NC			XXX
Channel 20 +		21			TBD
Channel 20 -		8			TBD
Channel 1gnd		NC			XXX
Channel 21 +		22			TBD
Channel 21 -		9			TBD
Channel 21gnd		NC			XXX
Channel 22 +		23			TBD
Channel 22 -		10			TBD
Channel 22gnd		NC			XXX
Channel 23 +		24			TBD
Channel 23 -		11			TBD
Channel 23gnd		NC			XXX
Channel 24 +		25			TBD
Channel 24 -		12			TBD
Channel 24gnd		NC			TBD
GND WIRE		13			XXX
Channel 25 +			1		TBD
Channel 25 -			14		TBD
Channel 25gnd			NC		XXX
Channel 26 +			2		TBD
Channel 26 -			15		TBD
Channel 26gnd			NC		XXX
Channel 27 +			3		TBD
Channel 27 -			16		TBD
Channel 27gnd			NC		XXX
Channel 28 +			4		TBD
Channel 28 -			17		TBD
Channel 28gnd			NC		XXX
Channel 29 +			5		TBD
Channel 29 -			18		TBD
Channel 29gnd			NC		XXX
Channel 30 +			6		TBD
Channel 30 -			19		TBD
Channel 30gnd			NC		XXX
Channel 31 +			20		TBD
Channel 31 -			7		TBD
Channel 31gnd			NC		XXX
Channel 32 +			21		TBD
Channel 32 -			8		TBD
Channel 32gnd			NC		XXX



# SPIRE HARNES DEFINITION

Doc #: SPIRE-RAL-PRJ-000608

Issue: 0.7

Date: 19/09/01

Page 67 of 136

Name	25way A	25wayB	25Way C	25way D	100Way #4
Channel 33 +			22		TBD
Channel 33 -			9		TBD
Channel 33gnd			NC		XXX
Channel 34 +			23		TBD
Channel 34 -			10		TBD
Channel 34gnd			NC		XXX
Channel 35 +			24		TBD
Channel 35 -			11		TBD
Channel 35gnd			NC		XXX
Channel 36 +			25		TBD
Channel 36 -			12		TBD
Channel 36gnd			NC		TBD
GND WIRE			13		XXX
Channel 37 +				1	TBD
Channel 37 -				14	TBD
Channel 37gnd				NC	XXX
Channel 38 +				2	TBD
Channel 38 -				15	TBD
Channel 38gnd				NC	XXX
Channel 39 +				3	TBD
Channel 39 -				16	TBD
Channel 39gnd				NC	XXX
Channel 40 +				4	TBD
Channel 40 -				17	TBD
Channel 40gnd				NC	XXX
Channel 41 +				5	TBD
Channel 41 -				18	TBD
Channel 41gnd				NC	XXX
Channel 42 +				6	TBD
Channel 42 -				19	TBD
Channel 42gnd				NC	XXX
Channel 43 +				20	TBD
Channel 43 -				7	TBD
Channel 43gnd				NC	XXX
Channel 44 +				21	TBD
Channel 44 -				8	TBD
Channel 44gnd				NC	XXX
Channel 45 +				22	TBD
Channel 45 -				9	TBD
Channel 45gnd				NC	XXX
Channel 46 +				23	TBD
Channel 46 -				10	TBD
Channel 46gnd				NC	XXX
Channel 47 +				24	TBD
Channel 47 -				11	TBD
Channel 47gnd				NC	XXX
Channel 48 +				25	TBD
Channel 48 -				12	TBD
Channel 48gnd				NC	TBD
GND WIRE				13	XXX

XXX= on ground wire ring, supported by the 4 otherwise unused contacts.



# SPIRE HARNES DEFINITION

Doc #: SPIRE-RAL-PRJ-000608  
Issue: 0.7  
Date: 19/09/01  
Page 68 of 136

## 4.3.5 C5 CVV5 to HSJFP Type1

Overall Mechanical Drwg.

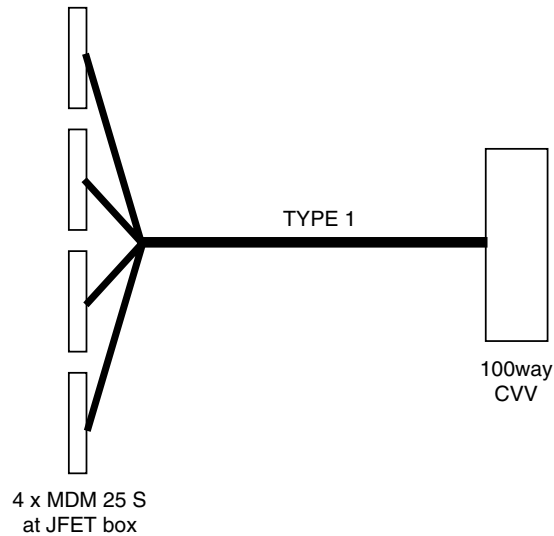

### Connector/Backshell Details

MDM 25 S +xxxx: interface to HSJFP9 J17  
MDM 25 S +xxxx: interface to HSJFP9 J18  
MDM 25 S +xxxx: interface to HSJFP10 J19  
MDM 25 S +xxxx: interface to HSJFP10 J20

### Harness Layup

As C4.

### Contact Details

As C4.



# SPIRE HARNESS DEFINITION

Doc #: SPIRE-RAL-PRJ-000608  
Issue: 0.7  
Date: 19/09/01  
Page 69 of 136

## 4.3.6 C6 CVV6 to HSJFP Type1

Overall Mechanical Drwg.

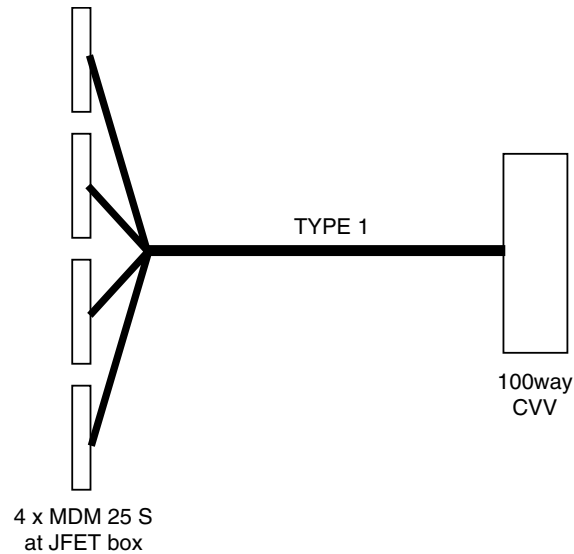

### Connector/Backshell Details

MDM 25 S +xxxx: interface to HSJFP7 J13  
MDM 25 S +xxxx: interface to HSJFP7 J14  
MDM 25 S +xxxx: interface to HSJFP8 J15  
MDM 25 S +xxxx: interface to HSJFP8 J16

### Harness Layup

As C4.

### Contact Details

As C4.



# SPIRE HARNES DEFINITION

Doc #: SPIRE-RAL-PRJ-000608  
Issue: 0.7  
Date: 19/09/01  
Page 70 of 136

## 4.3.7 C7 CVV7 to HSJFP Type1

Overall Mechanical Drwg.

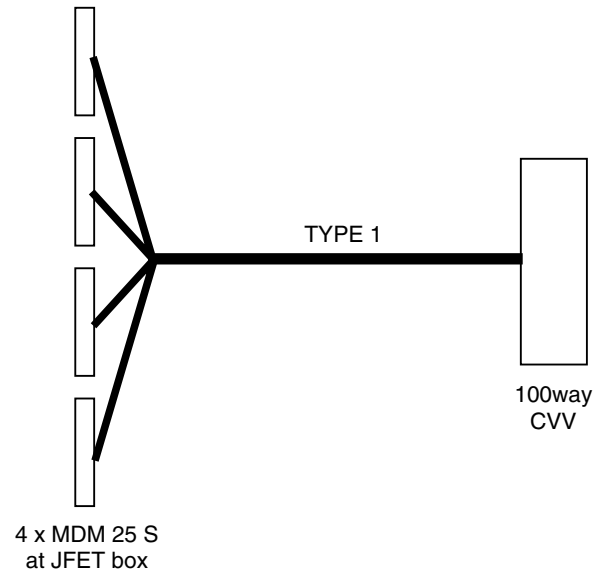

### Connector/Backshell Details

MDM 25 S +xxxx: interface to HSJFP5 J9  
MDM 25 S +xxxx: interface to HSJFP5 J10  
MDM 25 S +xxxx: interface to HSJFP6 J11  
MDM 25 S +xxxx: interface to HSJFP6 J12

### Harness Layup

As C4.

### Contact Details

As C4.



# SPIRE HARNES DEFINITION

Doc #: SPIRE-RAL-PRJ-000608  
Issue: 0.7  
Date: 19/09/01  
Page 71 of 136

## 4.3.8 C8 CVV8 to HSJFP Type1

Overall Mechanical Drwg.

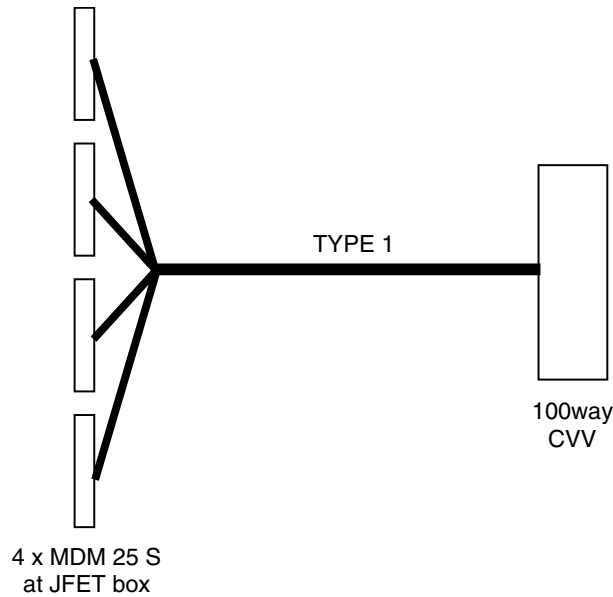

### Connector/Backshell Details

MDM 25 S +xxxx: interface to HSJFP3 J5  
MDM 25 S +xxxx: interface to HSJFP3 J6  
MDM 25 S +xxxx: interface to HSJFP4 J7  
MDM 25 S +xxxx: interface to HSJFP4 J8

### Harness Layup

As C4.

### Contact Details

As C2



# SPIRE HARNES DEFINITION

Doc #: SPIRE-RAL-PRJ-000608  
Issue: 0.7  
Date: 19/09/01  
Page 72 of 136

## 4.3.9 C9 CVV9 to HSJFP Type1

Overall Mechanical Drwg.

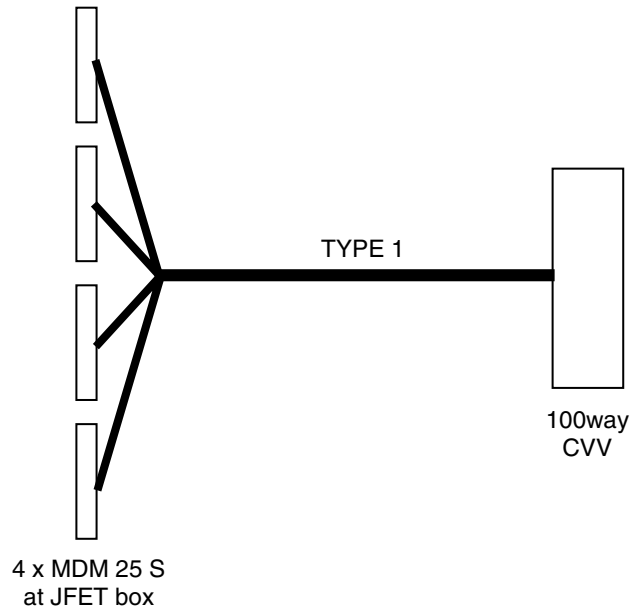

### Connector/Backshell Details

MDM 25 S +xxxx: interface to HSJFP1 J1  
MDM 25 S +xxxx: interface to HSJFP1 J2  
MDM 25 S +xxxx: interface to HSJFP2 J3  
MDM 25 S +xxxx: interface to HSJFP2 J4

### Harness Layup

As C4.

### Contact Details

As C4.





# SPIRE HARNES DEFINITION

Doc #: SPIRE-RAL-PRJ-000608  
Issue: 0.7  
Date: 19/09/01  
Page 73 of 136

## 4.3.10 C10 CVV10 to HSFPU AUX-P

### Overall Mechanical Drwg.

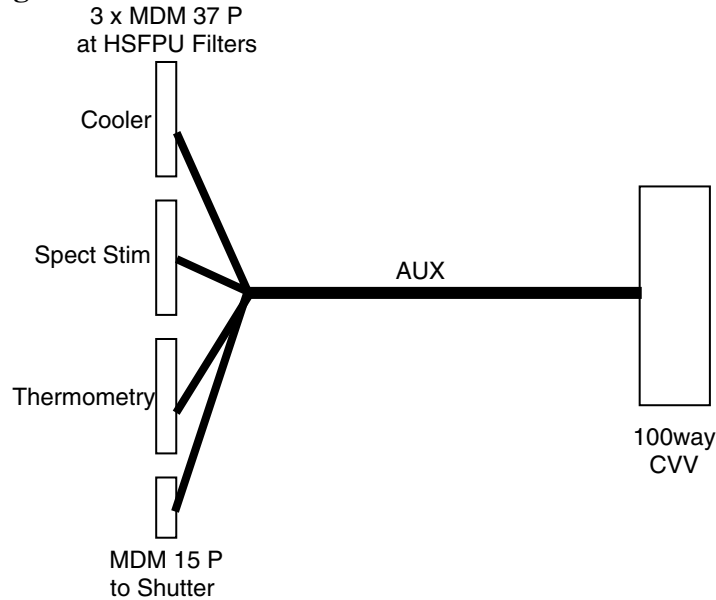

### Connector/Backshell Details

Prime side harness

MDM 37 P + XXXX: interface to HSFPU Filter FA J19 for Cooler

MDM 37 P + XXXX: interface to HSFPU Filter FA J21 for Spectrometer Stim

MDM 37 P + XXXX: interface to HSFPU Filter FB J23 for Thermometry

MDM 15 P + XXXX: interface to HSJFS J17 Shutter

### Harness Layup

#### Cooler Tail

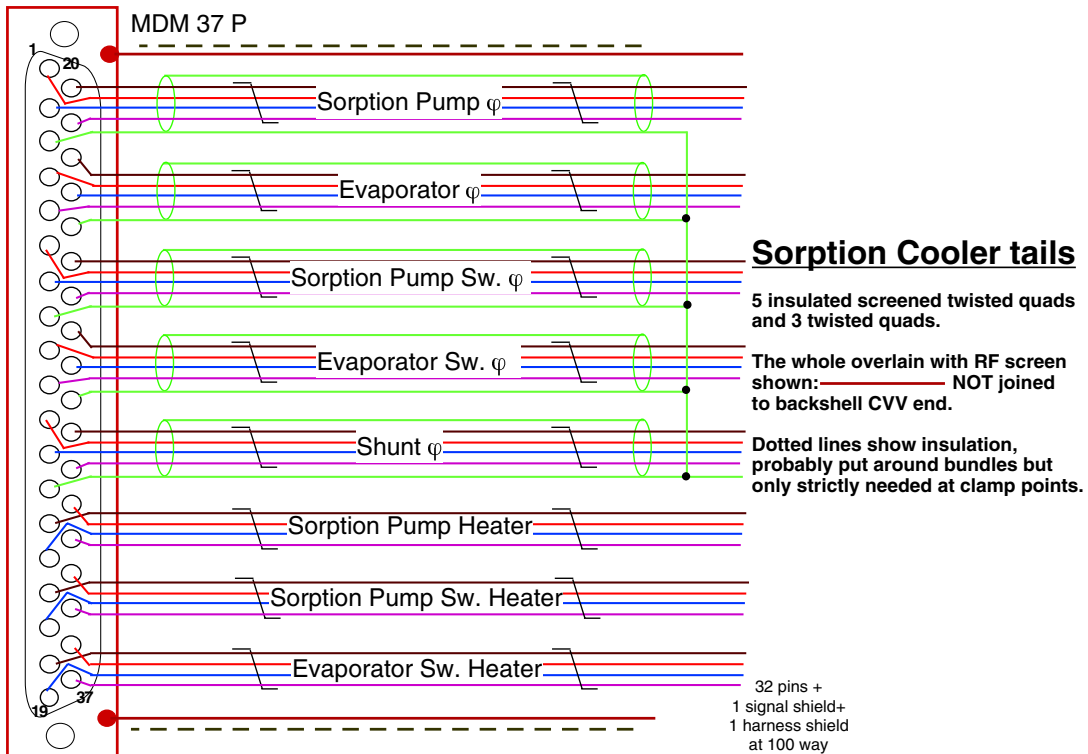



# SPIRE HARNES DEFINITION

Doc #: SPIRE-RAL-PRJ-000608  
Issue: 0.7  
Date: 19/09/01  
Page 74 of 136

## Spect. Stimulus Tail

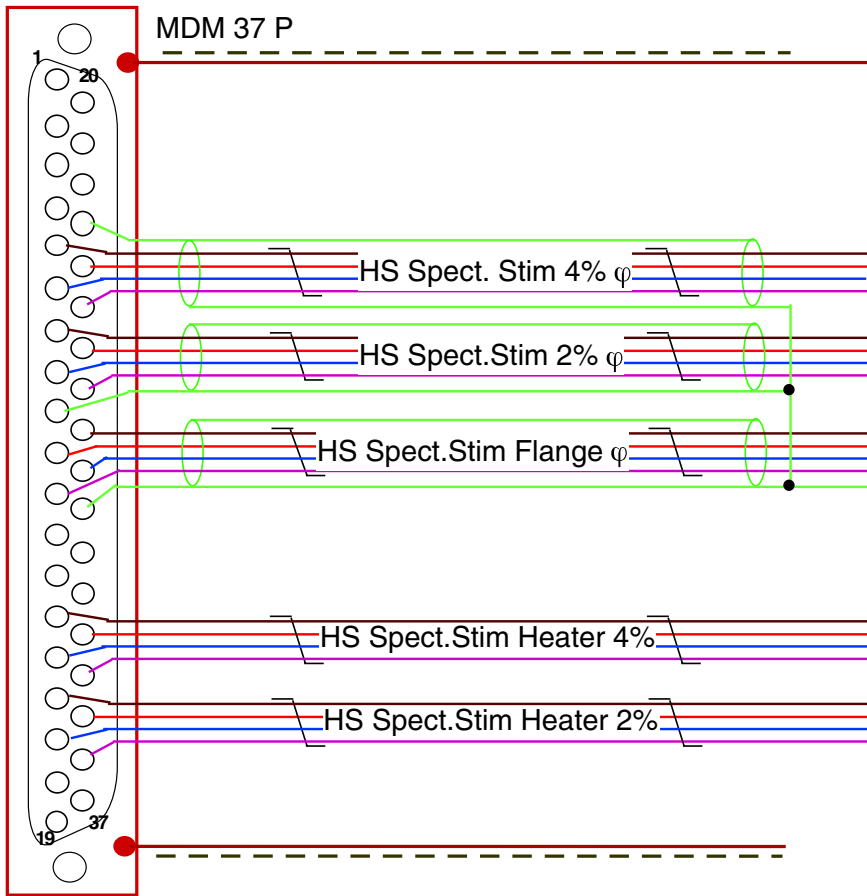

### **Spectrometer Stimulus tails**

3 insulated screened twisted quads  
and 2 insulated twisted quads.

The whole overlain with RF screen  
shown: — NOT joined  
to backshell CVV end.

Dotted lines show insulation,  
probably put around bundles but  
only strictly needed at clamp points.

20 pins +  
1 signal shield +  
harness shield  
at 100 way

## HSFPU Thermometry Tail

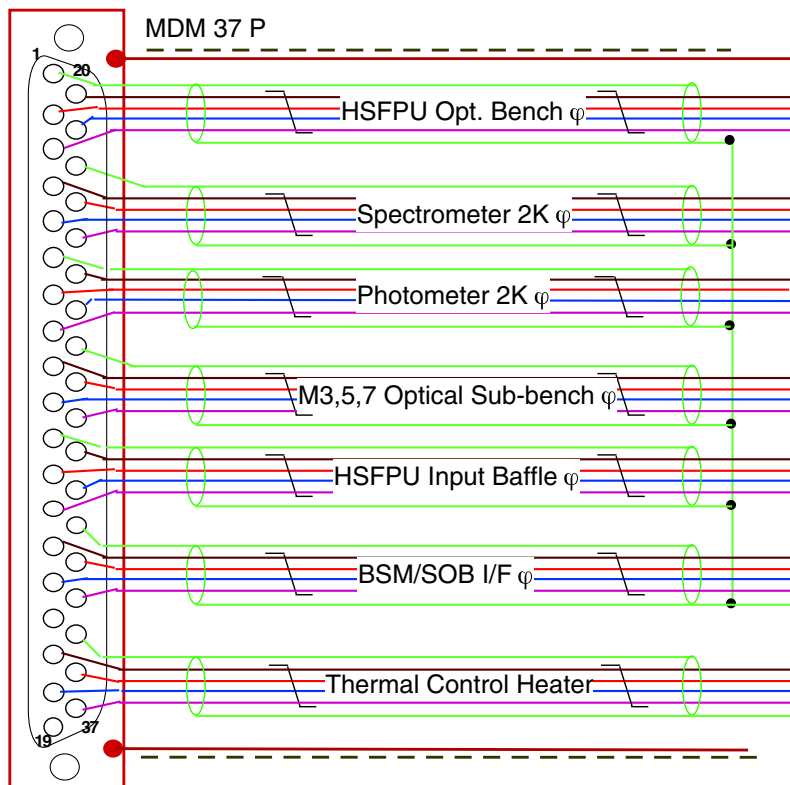

### **Thermometry tails**

7 insulated screened twisted quads.

The whole overlain with RF screen  
shown: — NOT joined  
to backshell CVV end.

Dotted lines show insulation,  
probably put around bundles but  
only strictly needed at clamp points.

28 pins +  
2 signal grounds +  
harness screen  
at 100way



# SPIRE HARNES DEFINITION

Doc #: SPIRE-RAL-PRJ-000608  
Issue: 0.7  
Date: 19/09/01  
Page 75 of 136

## Shutter Tail

This is a longer tail by about 600mm than those that terminate into HSFPU filters because it is routed outside HSFPU to the shutter unit itself.

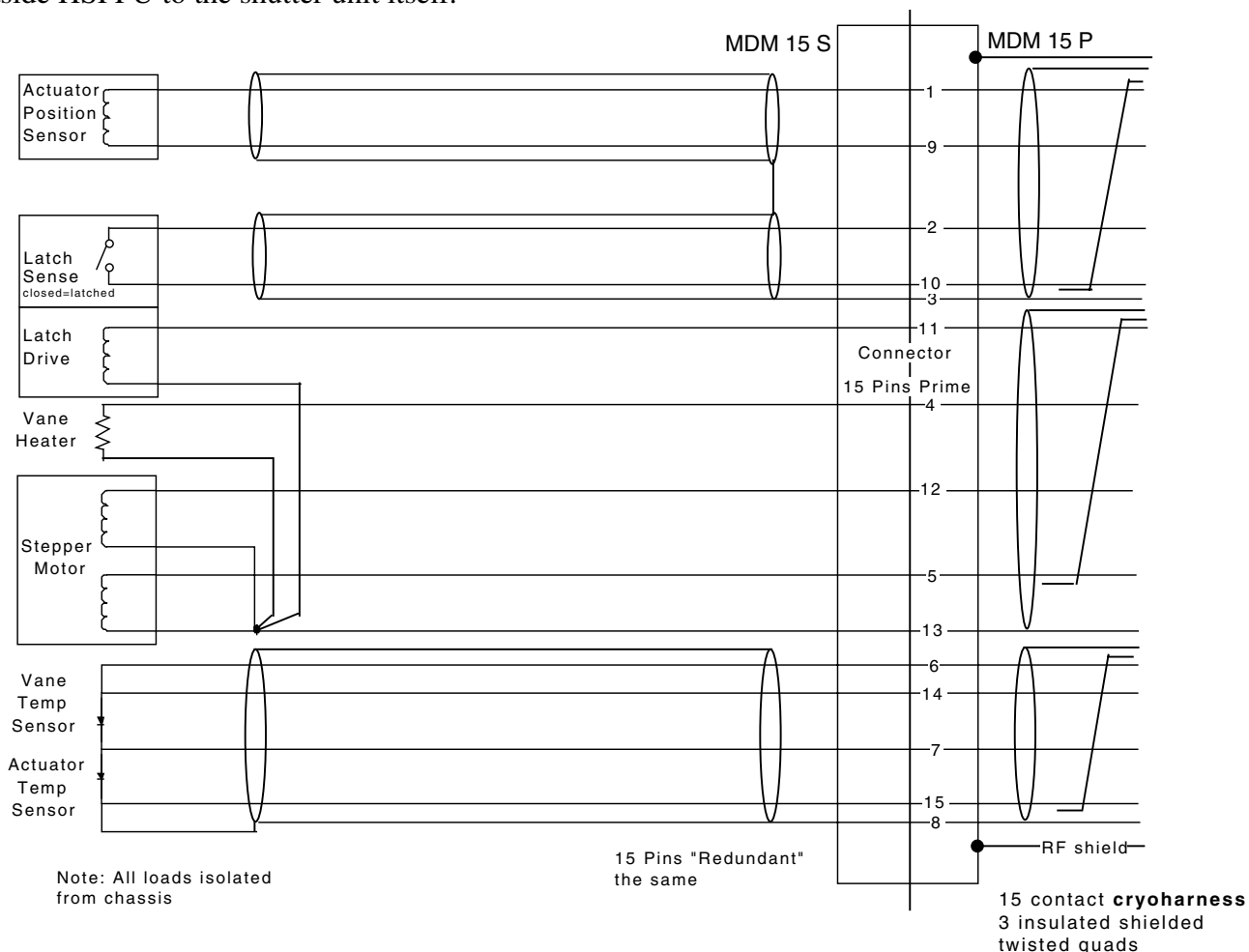

The number of wires to pass through the 100 way accumulates as follows:

Tail Source	"Signals"	Shields etc.	Harness Shld.	
Cooler	32	1	0.25	
Spectrometer Stimulus	20	1	0.25	
Thermometry	28	2	0.25	
Shutter	12	3	0.25	
<b>Total</b>	92	7	1	<b>100 in all!</b>

The C10 harness contacts are tabulated on the following pages. Note that C10 is a PRIME harness and all wires herein (excepting the shutter function) are PRIME, although this is not explicitly written ad nauseam.

The above layouts show one further feature, it is in the Thermometry Tail. The number of wires do not appear to add up correctly! The cryoharness permits implementing an option that cannot yet be determined. There are 4 wires harnessed to run a 300mK thermostating heater. They fit OK on the 37way. If system is implemented, harness F20 will include the links on thermometer sensor current feeds shown dotted. The sensors are then conditioned in 4 pairs. Four of the 8 wires thus saved on the 100way CVV are used to power the 300mK heater. (System duplicated via C12 and F21).



# SPIRE HARNES DEFINITION

Doc #: SPIRE-RAL-PRJ-000608  
 Issue: 0.7  
 Date: 19/09/01  
 Page 76 of 136

## Cooler Tail Listing

Function	37way J19	Max. current	Wire lay-up	Max Ohms	100way #10
Sorption Pump temperature I+	20	1 $\mu$ A	Insulated screened twisted quad	1000	
Sorption Pump temperature V+	1	N/A		1000	
Sorption Pump temperature V-	2	N/A		1000	
Sorption Pump temperature I-	21	1 $\mu$ A		1000	
Sorption Pump temperature shld*	3	N/A		N/A	
Evaporator temperature I+	22	250 nA	Insulated screened twisted quad	1000	
Evaporator temperature V+	4	N/A		1000	
Evaporator temperature V-	5	N/A		1000	
Evaporator temperature I-	23	250 nA		1000	
Evaporator temperature shld*	24	N/A		N/A	
Sorption Pump Heat Switch temperature I+	25	1 $\mu$ A	Insulated screened twisted quad	1000	
Sorption Pump Heat Switch temperature V+	6	N/A		1000	
Sorption Pump Heat Switch temperature V-	7	N/A		1000	
Sorption Pump Heat Switch temperature I-	26	1 $\mu$ A		1000	
Sorption Pump Heat Switch temperature shld*	8	N/A		N/A	
Evaporator Heat Switch temperature I+	27	1 $\mu$ A	Insulated screened twisted quad	1000	
Evaporator Heat Switch temperature V+	9	N/A		1000	
Evaporator Heat Switch temperature V-	10	N/A		1000	
Evaporator Heat Switch temperature I-	28	1 $\mu$ A		1000	
Evaporator Heat Switch temperature shld*	29	N/A		N/A	
Thermal Shunt temperature I+_A	30	1 $\mu$ A	Insulated screened twisted quad	1000	
Thermal Shunt temperature V+_B	11	N/A		1000	
Thermal Shunt temperature V-_A	12	N/A		1000	
Thermal Shunt temperature I-_B	31	1 $\mu$ A		1000	
Thermal Shunt temperature shld*	13	N/A		N/A	
Sorption Pump heater I+_A	14	25 mA	twisted quad	10	
Sorption Pump heater I+_B	32	25 mA		10	
Sorption Pump heater I-_A	15	25 mA		10	
Sorption Pump heater I-_B	33	25 mA		10	
Sorption Pump Heat Switch heater I+_A	16	1.5 mA	twisted quad	50	
Sorption Pump Heat Switch heater I+_B	34	1.5 mA		50	
Sorption Pump Heat Switch heater I-_A	17	1.5 mA		50	
Sorption Pump Heat Switch heater I-_B	35	1.5 mA		50	
Evaporator Heat Switch heater I+_A	18	1.5 mA	twisted quad	50	
Evaporator Heat Switch heater I+_B	36	1.5 mA		50	
Evaporator Heat Switch heater I-_A	19	1.5 mA		50	
Evaporator Heat Switch heater I-_B	37	1.5 mA		50	

\*=linked

32 wires and 1 temperature sensor signal shield



# SPIRE HARNES DEFINITION

Doc #: SPIRE-RAL-PRJ-000608  
 Issue: 0.7  
 Date: 19/09/01  
 Page 77 of 136

## Spectrometer Stimulus Tail Listing

Function	37way J21	Max. current	Wire lay-up	Max Ohms	100way #10
HS Spect. 4% temperature I+	5	1 $\mu$ A	Insulated screened twisted quad	1000	
HS Spect. 4% temperature V+	6	N/A		1000	
HS Spect. 4% temperature V-	24	N/A		1000	
HS Spect. 4% temperature I-	25	1 $\mu$ A		1000	
HS Spect. 4% temperature shld*	23	N/A		N/A	
HS Spect. 2% temperature I+	7	1 $\mu$ A	Insulated screened twisted quad	1000	
HS Spect. 2% temperature V+	8	N/A		1000	
HS Spect. 2% temperature V-	26	N/A		1000	
HS Spect. 2% temperature I-	27	1 $\mu$ A		1000	
HS Spect. 2% temperature shld*	9	N/A		N/A	
HS Spect. Stim Flange temperature I+	10	1 $\mu$ A	Insulated screened twisted quad	1000	
HS Spect. Stim Flange temperature V+	11	N/A		1000	
HS Spect. Stim Flange temperature V-	28	N/A		1000	
HS Spect. Stim Flange temperature I-	29	1 $\mu$ A		1000	
HS Spect. Stim Flange temperature shld*	30	N/A		N/A	
HS Spect. 4% heater I+_A	14	9 mA	twisted quad	30	
HS Spect. 4% heater I+_B	15	9 mA		30	
HS Spect. 4% heater I-_A	33	9 mA		30	
HS Spect. 4% heater I-_B	34	9 mA		30	
HS Spect. 2% heater I+_A	16	7 mA	twisted quad	30	
HS Spect. 2% heater I+_B	17	7 mA		30	
HS Spect. 2% heater I-_A	35	7 mA		30	
HS Spect. 2% heater I-_B	36	7 mA		30	

20 wires + 1 temperature sensor signal shield

## Shutter tail

Function	Pin # on J17	Max Current	Wire lay-up	Max Ohms*
Actuator Position Sensor +	1		Insulated screened twisted quad	1000
Actuator Position Sensor -	9			1000
Latch Sense +	2			1000
Latch Sense -	10			1000
Sense Shld	3			1000
Latch Drive +	11		Insulated screened twisted quad	10
Vane Heater+	4			10
Stepper Drive Phase A +	12			10
Stepper Drive Phase B +	5			10
Power Ground / Rtn. as shld	13			10
Temp Sensor Bias+	6		Insulated screened twisted quad	1000
Vane Temp V+	14			1000
Common Temp V	7			1000
Actuator Temp V-	15			1000
Temp Sensor Bias -/Shld	8			1000

12wires + 3 shields



# SPIRE HARNESS DEFINITION

Doc #: SPIRE-RAL-PRJ-000608  
 Issue: 0.7  
 Date: 19/09/01  
 Page 78 of 136

## FPU Thermometry Listing

Function	37way J23	Max. current	Wire lay-up	Max Ohms	100way #10
HSFPU Opt. Bench temperature I+	20	1 $\mu$ A	Insulated screened twisted quad	1000	
HSFPU Opt. Bench temperature V+	2	N/A		1000	
HSFPU Opt. Bench temperature V-	3	N/A		1000	
HSFPU Opt. Bench temperature I-	21	1 $\mu$ A		1000	
HSFPU Opt. Bench temperature shld*	1	N/A		N/A	
Spectrometer 2K box temperature I+	4	1 $\mu$ A	Insulated screened twisted quad	1000	
Spectrometer 2K box temperature V+	23	N/A		1000	
Spectrometer 2K box temperature V-	24	N/A		1000	
Spectrometer 2K box temperature I-	5	1 $\mu$ A		1000	
Spectrometer 2K box temperature shld*	22	N/A		N/A	
Photometer 2K box temperature I+	25	1 $\mu$ A	Insulated screened twisted quad	1000	
Photometer 2K box temperature V+	7	N/A		1000	
Photometer 2K box temperature V-	8	N/A		1000	
Photometer 2K box temperature I-	26	1 $\mu$ A		1000	
Photometer 2K box temperature shld*	6	N/A		N/A	
M3,5,7 Optical Subench temperature I+	9	1 $\mu$ A	Insulated screened twisted quad	1000	
M3,5,7 Optical Subench temperature V+	28	N/A		1000	
M3,5,7 Optical Subench temperature V-	29	N/A		1000	
M3,5,7 Optical Subench temperature I-	10	1 $\mu$ A		1000	
M3,5,7 Optical Subench temperature shld*	27	N/A		N/A	
HSFPU Input Baffle temperature I+	30	1 $\mu$ A	Insulated screened twisted quad	1000	
HSFPU Input Baffle temperature V+	12	N/A		1000	
HSFPU Input Baffle temperature V-	13	N/A		1000	
HSFPU Input Baffle temperature I-	31	1 $\mu$ A		1000	
HSFPU Input Baffle temperature shld*	11	N/A		N/A	
BSM/SOB I/F temperature I+	14	1 $\mu$ A	Insulated screened twisted quad	1000	
BSM/SOB I/F temperature V+	33	N/A		1000	
BSM/SOB I/F temperature V-	34	N/A		1000	
BSM/SOB I/F temperature I-	15	1 $\mu$ A		1000	
BSM/SOB I/F temperature shld*	32	N/A		N/A	
Thermal Control Heater I+_A	17	2mA	Insulated screened twisted quad	100	
Thermal Control Heater I+_B	18	2 mA		100	
Thermal Control Heater I-_A	36	2 mA		100	
Thermal Control Heater I-_B	37	2 mA		100	
Thermal Control Heater shld.	35	N/A		N/A	

\* = linked.

Total contacts 28 wires and 2 shields



# SPIRE HARNES DEFINITION

Doc #: SPIRE-RAL-PRJ-000608  
Issue: 0.7  
Date: 19/09/01  
Page 79 of 136

## 4.3.11 C11 CVV11 to HSFPU DRV-P

### Overall Mechanical Drwg.

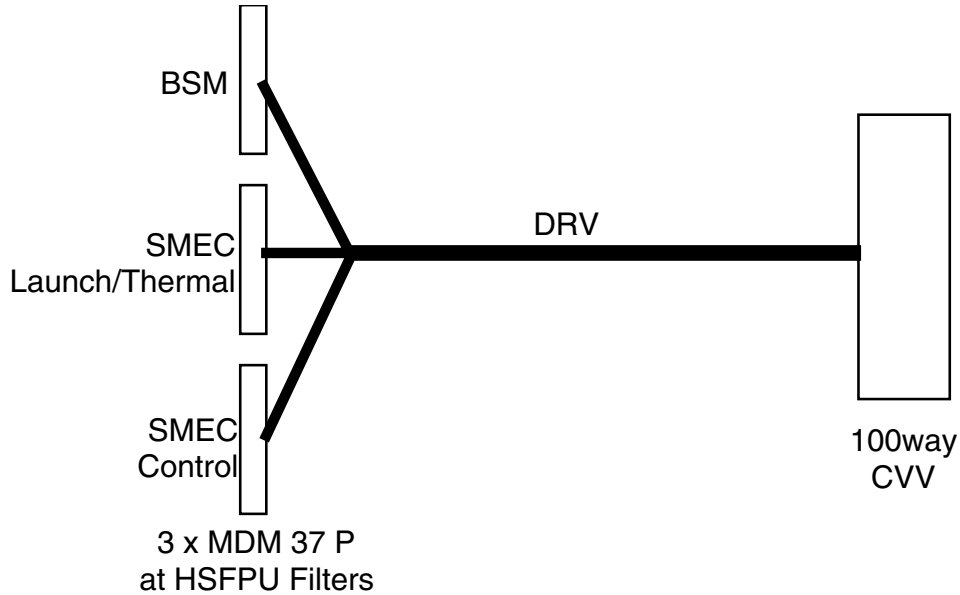

### Connector/Backshell Details

Redundant side harness

MDM 37 P + XXXX: interface to HSFPU Filter FB J25

MDM 37 P + XXXX: interface to HSFPU Filter FC J27

MDM 37 P + XXXX: interface to HSFPU Filter FC J29

### Harness Layup

BSM Tail

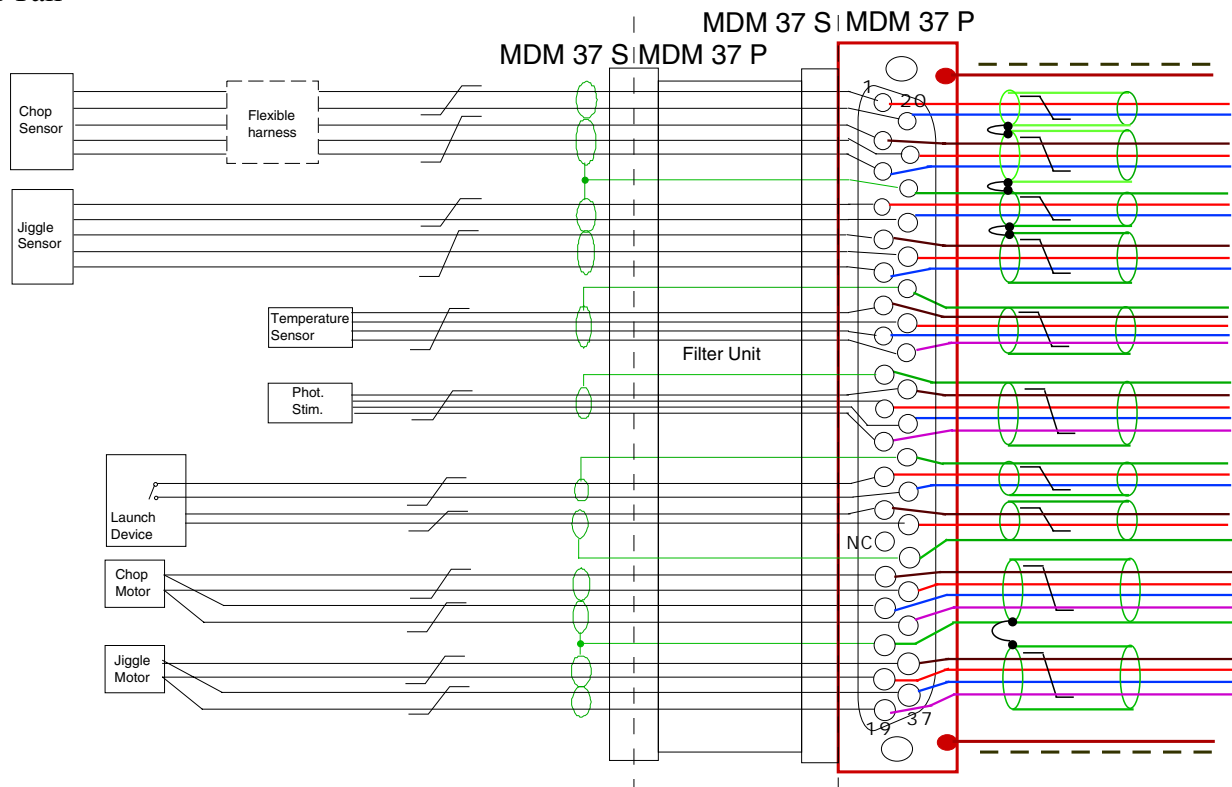



# SPIRE HARNES DEFINITION

Doc #: SPIRE-RAL-PRJ-000608  
Issue: 0.7  
Date: 19/09/01  
Page 80 of 136

## SMEC Launch/Thermal Tail

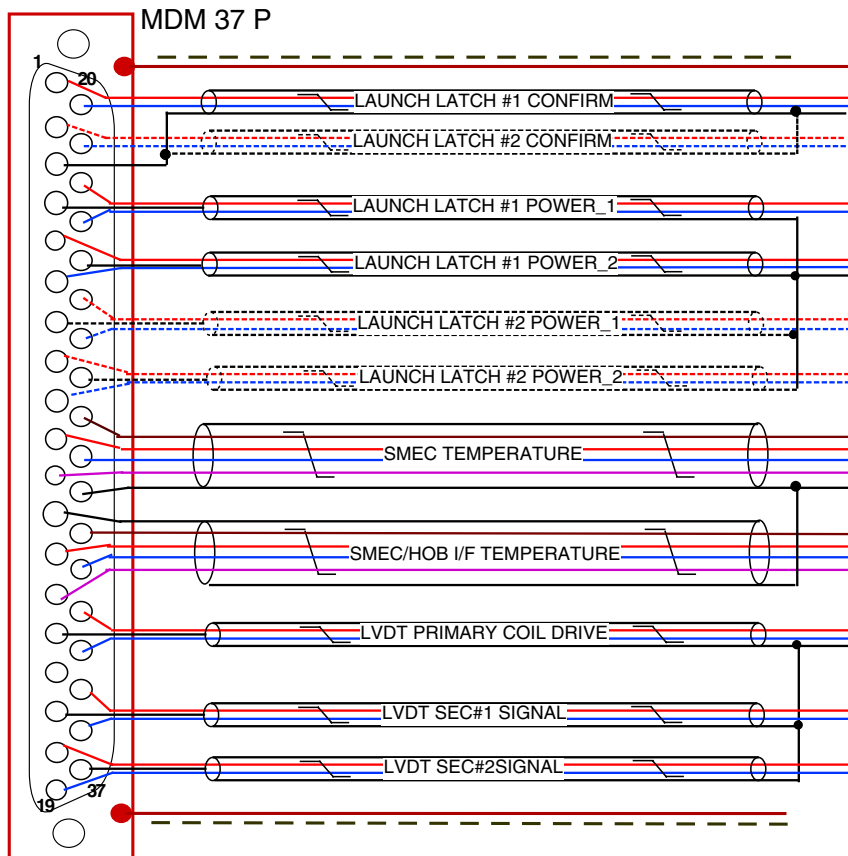

### SMEC Launch/Thermal Tail

9(6) insulated screened twisted pairs  
and 2 insulated screened twisted quads.

The whole overlain with RF screen  
shown: —— NOT joined  
to backshell CVV end.

Dotted outer lines show insulation,  
probably put around bundles but  
only strictly needed at clamp points.

Dotted conductors are TBC

26 (20) signal pins +  
4 signal grounds +  
harness screen  
at 100way

## SMEC Control Tail

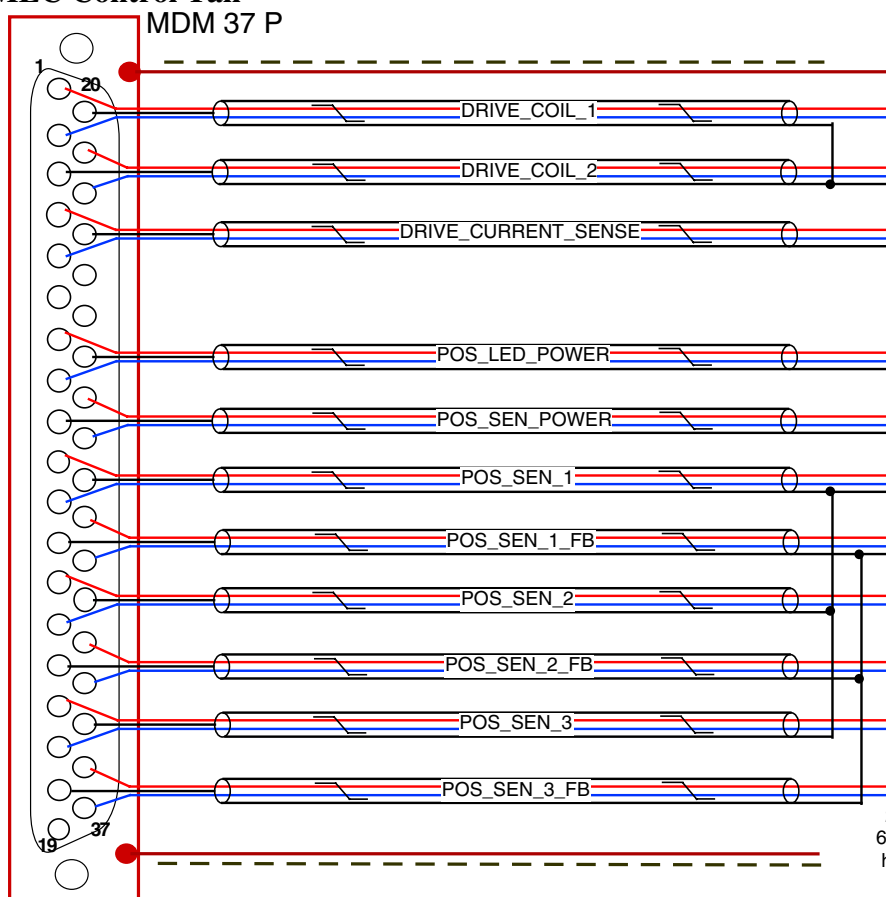

### SMEC Control Tail

11 insulated screened twisted pairs.

The whole overlain with RF screen  
shown: —— NOT joined  
to backshell CVV end.

Dotted lines show insulation,  
probably put around bundles but  
only strictly needed at clamp points.

22 signal pins +  
6 signal grounds +  
harness screen  
at 100way





# SPIRE HARNESS DEFINITION

Doc #: SPIRE-RAL-PRJ-000608  
Issue: 0.7  
Date: 19/09/01  
Page 81 of 136

## BSM Tail Listing

Function	37way J25	Max. current	Wire lay-up	Max Ohms	100way #11
Chop Position Sensor 1	1	1 $\mu$ A	Insulated screened twisted pair	1000	
Chop Position Sensor 2	20	N/A		1000	
Chop Position Sensor shld1	to A	N/A		N/A	linked
Chop Position Sensor 3	2	250 nA	Insulated screened twisted triple	1000	
Chop Position Sensor 4	21	N/A		1000	
Chop Position Sensor 5	3	N/A		1000	
Chop Position Sensor shld2=A	22	N/A		N/A	
Jiggle Position Sensor 1	4	1 $\mu$ A	Insulated screened twisted pair	1000	
Jiggle Position Sensor 2	23	N/A		1000	
Jiggle Position Sensor shld1	to B	N/A		N/A	linked
Jiggle Position Sensor 3	5	250 nA	Insulated screened twisted triple	1000	
Jiggle Position Sensor 4	24	N/A		1000	
Jiggle Position Sensor 5	6	N/A		1000	
Jiggle Position Sensor shld2=B	22	N/A		N/A	
BSM temperature I+	7	1 $\mu$ A	Insulated screened twisted quad	1000	
BSM temperature V+	26	N/A		1000	
BSM temperature V-	8	N/A		1000	
BSM temperature I-	27	1 $\mu$ A		1000	
BSM temperature shld	25	N/A		N/A	
Photometer Point Stim. heater I+ _A	28	7 mA	Insulated screened twisted quad	10	
Photometer Point Stim.heater I+ _B	10	7 mA		10	
Photometer Point Stim.heater I- _A	29	7 mA		10	
Photometer Point Stim.heater I- _B	11	7 mA		10	
Photometer Point Stim.heater shld	9	N/A		N/A	
BSM Launch latch confirmation 1	30	1mA	Insulated screened twisted pair	1000	
BSM Launch latch confirmation 2	12	1mA		1000	
Launch latch confirmation shld to platform gnd	31	N/A		N/A	
BSM Launch latch drive +	13	35mA	Insulated screened twisted triple	10	
BSM Launch latch drive -	32	35mA		10	
BSM Launch latch drive shld	33	N/A		N/A	
Chop Motor Drive 1	15	40 mA	Insulated screened twisted quad	10	
Chop Motor Drive 2	34	40 mA		10	
Chop Motor Drive 3	16	40 mA		10	
Chop Motor Drive 4	35	40 mA		10	
Chop Motor Drive shld	17	N/A		N/A	
Chop Motor Drive 1	36	40 mA	Insulated screened twisted quad	10	
Chop Motor Drive 2	18	40 mA		10	
Chop Motor Drive 3	37	40 mA		10	
Chop Motor Drive 4	19	40 mA		10	
Chop Motor Drive shld	17	N/A		N/A	linked

This 37way connector is has 36 ways populated.

Commoning the Launch Latch Drive shield with that of the motor drives and reassigning launch latch drive 3 would give the BSM a slightly messy 2 wire cryoharness "contingency".

The photometer point stimulus heater shield may be denied a contact on the 100way depending on demand by the SMEC tails, TBC. In which case, and only this case, it would be grounded in the BSM.



# SPIRE HARNES DEFINITION

Doc #: SPIRE-RAL-PRJ-000608  
Issue: 0.7  
Date: 19/09/01  
Page 82 of 136

## SMEC Launch/Therm.Tail Listing

Function	37way J27	Max. current	Wire lay-up	Max Ohms	100way #11
SMEC launch latch # 1 confirmation +	1	1 mA	Insulated screened twisted pair	5	
SMEC launch latch # 1 confirmation -	20	1 mA		5	
SMEC launch latch # 1 confirmation Shield	3	N/A		N/A	A [noisy SVM]
SMEC launch latch # 2 confirmation + TBC	2	1 mA	Insulated screened twisted pair	5	
SMEC launch latch # 2 confirmation - TBC	21	1 mA		5	
SMEC launch latch # 2 confirmation Shld TBC	3	N/A		N/A	A[noisy SVM]
SMEC launch latch #1 power supply_1	21	400 mA / 50ms	Insulated screened twisted pair	5	
SMEC launch latch #1 power return_1	22	400 mA / 50ms		5	
SMEC launch latch #1 power Shield_1	4	N/A		N/A	B
SMEC launch latch #1 power supply_2	5	400 mA / 50ms	Insulated screened twisted pair	5	
SMEC launch latch #1 power return_2	6	400 mA / 50ms		5	
SMEC launch latch #1 power Shield_2	23	N/A		N/A	B
SMEC launch latch #2 power supply_1	24	400 mA / 50ms	Insulated screened twisted pair	5	
SMEC launch latch #2 power return_1	25	400 mA / 50ms		5	
SMEC launch latch #2 power Shield_1	7	N/A		N/A	B
SMEC launch latch #2 power supply_2 TBC	8	400 mA / 50ms	Insulated screened twisted pair	5	
SMEC launch latch #2 power return_2 TBC	9	400 mA / 50ms		5	
SMEC launch latch #2 power Shield_2 TBC	26	N/A		N/A	B
SMEC temperature I+	27	1 $\mu$ A	Insulated screened twisted quad	1000	
SMEC temperature V+	10	N/A		1000	
SMEC temperature V-	28	N/A		1000	
SMEC temperature I-	11	1 $\mu$ A		1000	
SMEC temperature shld	29	N/A		N/A	C
SMEC/SOB I/F temperature I+	30	1 $\mu$ A	Insulated screened twisted quad	1000	
SMEC/SOB I/F temperature V+	13	N/A		1000	
SMEC/SOB I/F temperature V-	31	N/A		1000	
SMEC/SOB I/F temperature I-	14	1 $\mu$ A		1000	
SMEC/SOB I/F temperature shld	12	N/A		N/A	C
SMEC LVDT primary coil power supply (P)	32	5 mA	Insulated screened twisted pair	5	
SMEC LVDT primary coil power supply (N)	33	5 mA		5	
SMEC LVDT primary coil power supply Shld	15	N/A		N/A	D
SMEC LVDT secondary coil # 1 signal (P)	35	50 $\mu$ A	Insulated screened twisted pair	5	
SMEC LVDT secondary coil # 1 signal (N)	36	50 $\mu$ A		5	
SMEC LVDT secondary coil # 1 signal Shield	17	N/A		N/A	D
SMEC LVDT secondary coil # 2 signal (P)	18	50 $\mu$ A	Insulated screened twisted pair	5	
SMEC LVDT secondary coil # 2 signal (N)	19	50 $\mu$ A		5	
SMEC LVDT secondary coil # 2 signal Shield	37	N/A		N/A	D

31 contacts used



# SPIRE HARNESS DEFINITION

Doc #: SPIRE-RAL-PRJ-000608  
Issue: 0.7  
Date: 19/09/01  
Page 83 of 136

## SMEC Control Tail Listing

Function	37way J29	Max. current	Wire lay-up	Max Ohms	100way #11
SMEC Drive Coil I+	1	100mA	Insulated screened twisted pair	5	
SMEC Drive Coil I-	2	100mA		5	
SMEC Drive Coil shld	20	N/A		N/A	A
SMEC Drive Coil (Rob) I+	21	100mA	Insulated screened twisted pair	5	
SMEC Drive Coil (Rob) I-	22	100mA		5	
SMEC Drive Coil (Rob) shld	3	N/A		N/A	A
SMEC Drive Coil Sense+	4	10 $\mu$ A	Insulated screened twisted pair	500	
SMEC Drive Coil Sense-	5	10 $\mu$ A		500	
SMEC Drive Coil shld	23	N/A		N/A	
SMEC position sensor Led power supply	7	1mA	Insulated screened twisted pair	100	
SMEC position sensor Led power return	8	1mA		100	
SMEC position sensor Led power Shield	26	N/A		N/A	
SMEC position sensor power supply	27	1mA	Insulated screened twisted pair	100	
SMEC position sensor power return	28	1mA		100	
SMEC position sensor power Shield	9	N/A		N/A	
SMEC position sensor photodiode #1 I+	10	20 $\mu$ A	Insulated screened twisted pair	1000	
SMEC position sensor photodiode #1 I-	11	20 $\mu$ A		1000	
SMEC position sensor photodiode Shield	29	N/A		N/A	B
SMEC pos. sensor photodiode #1 feedback +	30	10 $\mu$ A	Insulated screened twisted pair	1000	
SMEC pos. sensor photodiode #1 feedback -	31	10 $\mu$ A		1000	
SMEC pos. sensor photodiode feedback Shld	12	N/A		N/A	C
SMEC position sensor photodiode #2 I+	13	20 $\mu$ A	Insulated screened twisted pair	1000	
SMEC position sensor photodiode #2 I-	14	20 $\mu$ A		1000	
SMEC position sensor photodiode Shield	32	N/A		N/A	B
SMEC pos. sensor photodiode #2 feedback +	33	10 $\mu$ A	Insulated screened twisted pair	1000	
SMEC pos. sensor photodiode #2 feedback -	34	10 $\mu$ A		1000	
SMEC pos. sensor photodiode feedback Shld	15	N/A		N/A	C
SMEC position sensor photodiode #3 I+	16	20 $\mu$ A	Insulated screened twisted pair	1000	
SMEC position sensor photodiode #3 I-	17	20 $\mu$ A		1000	
SMEC position sensor photodiode Shield	35	N/A		N/A	B
SMEC pos. sensor photodiode #3 feedback +	36	10 $\mu$ A	Insulated screened twisted pair	1000	
SMEC pos. sensor photodiode #3 feedback -	37	10 $\mu$ A		1000	
SMEC pos. sensor photodiode feedback Shld	18	N/A		N/A	C

29 contacts used.

Total used through 100 way = 36 + 31 + 29 = 96.

SMEC above based on "Cryo\_harness\_010906.doc".



# SPIRE HARNES DEFINITION

Doc #: SPIRE-RAL-PRJ-000608  
Issue: 0.7  
Date: 19/09/01  
Page 84 of 136

## 4.3.12 C12 CVV12 to HSFPU AUX-R

### Overall Mechanical Drwg.

Redundant version of C10, and the same as it

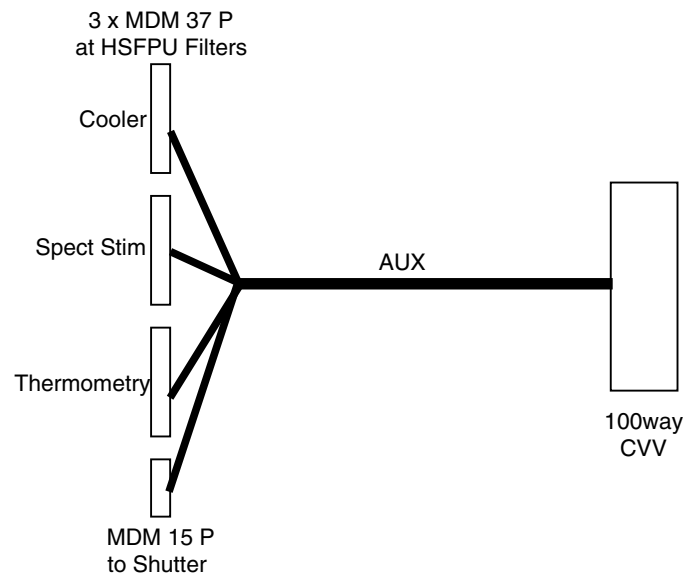

### Connector/Backshell Details

Prime side harness

MDM 37 S + XXXX: interface to HSFPU Filter FD J20 for Cooler

MDM 37 S + XXXX: interface to HSFPU Filter FD J22 for Stectrometer stimulus

MDM 37 S + XXXX: interface to HSFPU Filter FE J24 for Thermometry

MDM 15 P + XXXX: interface to HSJFS J18 Shutter

### Harness Layup

Redundant version of C10, and the same as it.

Add one to all the connector numbers compared to C10.



# SPIRE HARNES DEFINITION

Doc #: SPIRE-RAL-PRJ-000608  
Issue: 0.7  
Date: 19/09/01  
Page 85 of 136

## 4.3.13 C13 CVV13 to HSFPU DRV-R

### Overall Mechanical Drwg.

Format as C11, maybe differing length.

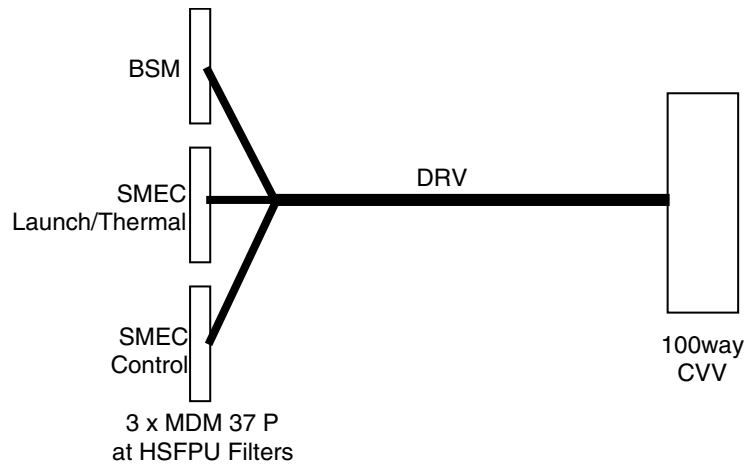

### Connector/Backshell Details

Redundant side harness

MDM 37 P + XXXX: interface to HSFPU Filter FE J26

MDM 37 P + XXXX: interface to HSFPU Filter FF J28

MDM 37 P + XXXX: interface to HSFPU Filter FF J30

### Harness Layup

As C11.

### Contact Details

As C11, but add one to all the connector numbers compared to C11.



# SPIRE HARNES DEFINITION

Doc #: SPIRE-RAL-PRJ-000608  
 Issue: 0.7  
 Date: 19/09/01  
 Page 86 of 136

## 4.4 FPU Harnesses

### 4.4.1 F1[A&B] PSW-A BDA to HSJFP

#### Overall Mechanical Drwg.

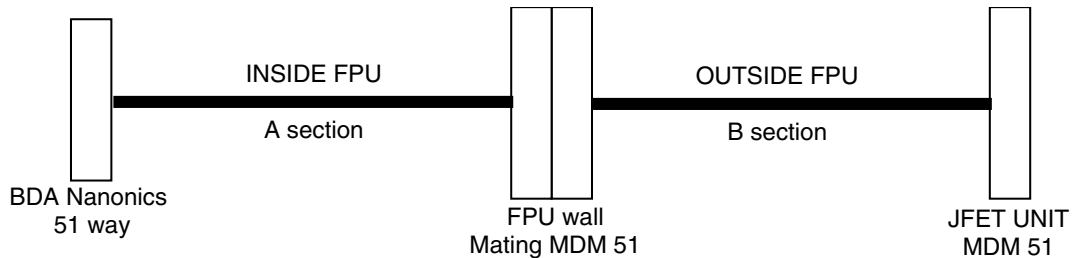

JPL configured Photometer BDA lead, maintaining Faraday cage HSJFP to FPU, and keeping signal ground separate from chassis ground.

#### Connector/Backshell Details

**A section:** Nanonics STM50PC2DC012N? to MDM51S mounted in wall

**B section:** MDM51P with XXXX to MDM51S with XXXX at JFET module.

#### Harness Layup

**B section** requires outer RF shield, **A section** does not.

**B section** may have thermal heatsink attachments, TBD.

Length and tie-downs optimised to minimise capacitance and microphony.

Consists of 6 x 12-ax, each carrying 4 channels, making 24 channels in all plus a screened twisted pair for bias.

Careful control of those screens that cannot have their own contact assignment.

#### Contact Details

Function	MDM51 contact	Cable	Nanonics contact
Channel A +	35	12-ax	1
Channel A -	51		26
Channel Agnd	To 12-ax shield one end		To 12-ax shield one end
Channel B +	17		2
Channel B -	18		27
Channel Bgnd	To 12-ax shield one end		To 12-ax shield one end
Channel C +	15		3
Channel C -	16		28
Channel Cgnd	To 12-ax shield one end		To 12-ax shield one end
Channel D +	34		4
Channel D -	50		29
Channel Dgnd	To 12-ax shield one end		To 12-ax shield one end
Channel E +	33	12-ax	5
Channel E -	49		30
Channel Egnd	To 12-ax shield one end		To 12-ax shield one end
Channel F +	13		6
Channel F -	14		31
Channel Fgnd	To 12-ax shield one end		To 12-ax shield one end
Channel G +	32		7
Channel G -	48		32
Channel Ggnd	To 12-ax shield one end		To 12-ax shield one end
Channel H +	31		8
Channel H-	47		33



# SPIRE HARNES DEFINITION

Doc #: SPIRE-RAL-PRJ-000608  
Issue: 0.7  
Date: 19/09/01  
Page 87 of 136

Function	MDM51 contact	Cable	Nanonics contact	
Channel Hgnd	To 12-ax shield one end		To 12-ax shield one end	
Channel I +	30	12-ax	9	
Channel I-	46		34	
Channel Ignd	To 12-ax shield one end		To 12-ax shield one end	
Channel J +	29		10	
Channel J-	45		35	
Channel Jgnd	To 12-ax shield one end		To 12-ax shield one end	
Channel K +	28		11	
Channel K -	44		36	
Channel Kgnd	To 12-ax shield one end		To 12-ax shield one end	
Channel L +	11		12	
Channel L -	12		37	
Channel Lgnd	To 12-ax shield one end		To 12-ax shield one end	
Channel M +	27		12-ax	13
Channel M-	43			38
Channel Mgnd	To 12-ax shield one end	To 12-ax shield one end		
Channel N +	26	14		
Channel N -	42	39		
Channel Ngnd	To 12-ax shield one end	To 12-ax shield one end		
Channel P +	9	15		
Channel P -	10	40		
Channel Pgnd	To 12-ax shield one end	To 12-ax shield one end		
Channel R +	25	16		
Channel R-	41	41		
Channel Rgnd	To 12-ax shield one end	To 12-ax shield one end		
Channel S+	24	12-ax		17
Channel S -	40			42
Channel Sgnd	To 12-ax shield one end		To 12-ax shield one end	
Channel T+	7		18	
Channel T -	8		43	
Channel Tgnd	To 12-ax shield one end		To 12-ax shield one end	
Channel U +	23		19	
Channel U -	36		44	
Channel Ugnd	To 12-ax shield one end		To 12-ax shield one end	
Channel V +	22		20	
Channel V-	38		45	
Channel Vgnd	To 12-ax shield one end		To 12-ax shield one end	
Channel W +	5		12-ax	21
Channel W -	6			46
Channel Wgnd	To 12-ax shield one end	To 12-ax shield one end		
Channel X +	21	22		
Channel X -	37	47		
Channel Xgnd	To 12-ax shield one end	To 12-ax shield one end		
Channel Y +	20	23		
Channel Y -	38	48		
Channel Ygnd	To 12-ax shield one end	To 12-ax shield one end		
Channel Z+	3	24		
Channel Z -	4	49		
Channel Zgnd	To 12-ax shield one end	To 12-ax shield one end		
Bias +	1	STT		25
Bias_	2			50
Bias gnd	19+commoned shlds		51+commoned shlds	

**N.B.** None of the gnds./braids in the above shall be connected to backshell and hence chassis.



# SPIRE HARNES DEFINITION

Doc #: SPIRE-RAL-PRJ-000608  
Issue: 0.7  
Date: 19/09/01  
Page 88 of 136

## 4.4.2 F2[A&B] PSW-B BDA to HSJFP

### Overall Mechanical Drwg.

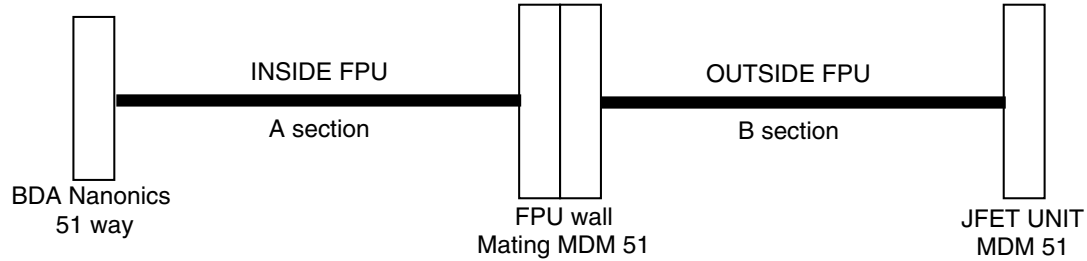

JPL configured Photometer BDA lead, maintaining Faraday cage HSJFP to FPU, and keeping signal ground separate from chassis ground.

### Connector/Backshell Details

**A section:** Nanonics STM50PC2DC012N? to MDM51S mounted in wall

**B section:** MDM51P with XXXX to MDM51S with XXXX at JFET module.

### Harness Layup

**B section** requires outer RF shield, **A section** does not.

**B section** may have thermal heatsink attachments, TBD.

As F1, length a variable

### Contact Details

as F1





# SPIRE HARNES DEFINITION

Doc #: SPIRE-RAL-PRJ-000608  
Issue: 0.7  
Date: 19/09/01  
Page 89 of 136

## 4.4.3 F3[A&B] PSW-C BDA to HSJFP

### Overall Mechanical Drwg.

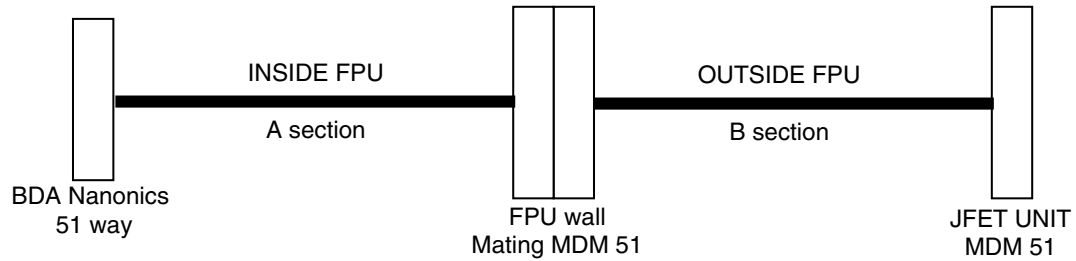

JPL configured Photometer BDA lead, maintaining Faraday cage HSJFP to FPU, and keeping signal ground separate from chassis ground.

### Connector/Backshell Details

**A** section: Nanonics STM50PC2DC012N? to MDM51S mounted in wall

**B** section: MDM51P with XXXX to MDM51S with XXXX at JFET module.

### Harness Layup

**B** section requires outer RF shield, **A** section does not.

**B** section may have thermal heatsink attachments, TBD.

As F1, length a variable

### Contact Details

as F1



# SPIRE HARNES DEFINITION

Doc #: SPIRE-RAL-PRJ-000608  
Issue: 0.7  
Date: 19/09/01  
Page 90 of 136

## 4.4.4 F4[A&B] PSW-D BDA to HSJFP

### Overall Mechanical Drwg.

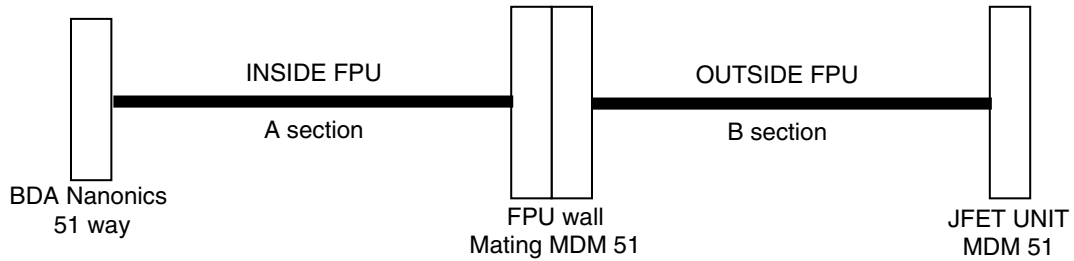

JPL configured Photometer BDA lead, maintaining Faraday cage HSJFP to FPU, and keeping signal ground separate from chassis ground.

### Connector/Backshell Details

**A** section: Nanonics STM50PC2DC012N? to MDM51S mounted in wall

**B** section: MDM51P with XXXX to MDM51S with XXXX at JFET module.

### Harness Layup

**B** section requires outer RF shield, **A** section does not.

**B** section may have thermal heatsink attachments, TBD.

As F1, length a variable

### Contact Details

as F1



# SPIRE HARNES DEFINITION

Doc #: SPIRE-RAL-PRJ-000608  
Issue: 0.7  
Date: 19/09/01  
Page 91 of 136

## 4.4.5 F5[A&B] PSW-E BDA to HSJFP

### Overall Mechanical Drwg.

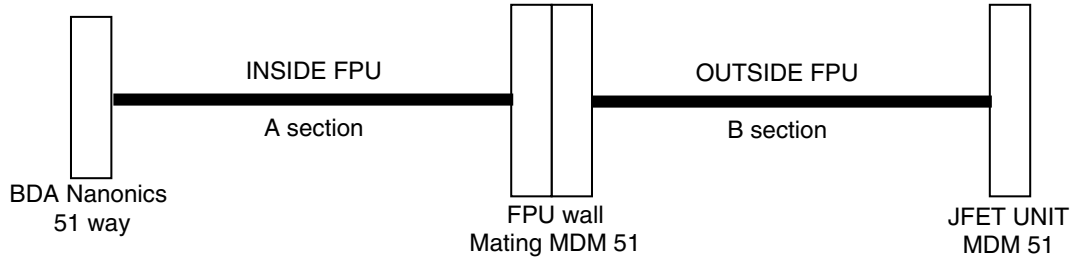

JPL configured Photometer BDA lead, maintaining Faraday cage HSJFP to FPU, and keeping signal ground separate from chassis ground.

### Connector/Backshell Details

**A** section: Nanonics STM50PC2DC012N? to MDM51S mounted in wall

**B** section: MDM51P with XXXX to MDM51S with XXXX at JFET module.

### Harness Layup

**B** section requires outer RF shield, **A** section does not.

**B** section may have thermal heatsink attachments, TBD.

As F1, length a variable

### Contact Details

as F1



# SPIRE HARNES DEFINITION

Doc #: SPIRE-RAL-PRJ-000608  
Issue: 0.7  
Date: 19/09/01  
Page 92 of 136

## 4.4.6 F6[A&B] PSW-F BDA to HSJFP

### Overall Mechanical Drwg.

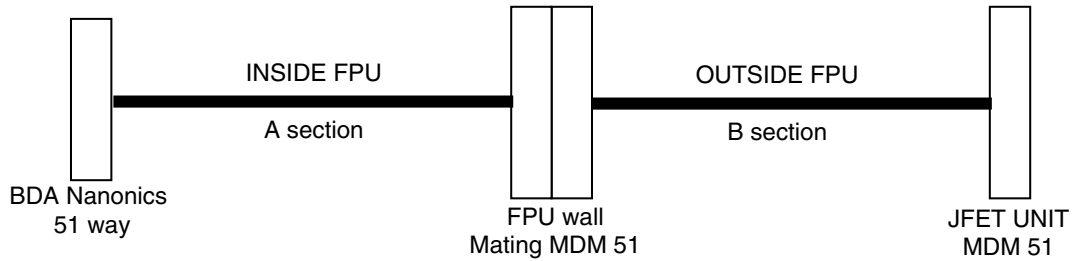

JPL configured Photometer BDA lead, maintaining Faraday cage HSJFP to FPU, and keeping signal ground separate from chassis ground.

### Connector/Backshell Details

**A** section: Nanonics STM50PC2DC012N? to MDM51S mounted in wall

**B** section: MDM51P with XXXX to MDM51S with XXXX at JFET module.

### Harness Layup

**B** section requires outer RF shield, **A** section does not.

**B** section may have thermal heatsink attachments, TBD.

As F1, length a variable

### Contact Details

as F1



# SPIRE HARNES DEFINITION

Doc #: SPIRE-RAL-PRJ-000608  
Issue: 0.7  
Date: 19/09/01  
Page 93 of 136

## 4.4.7 F7[A&B] PMW-A BDA to HSJFP

### Overall Mechanical Drwg.

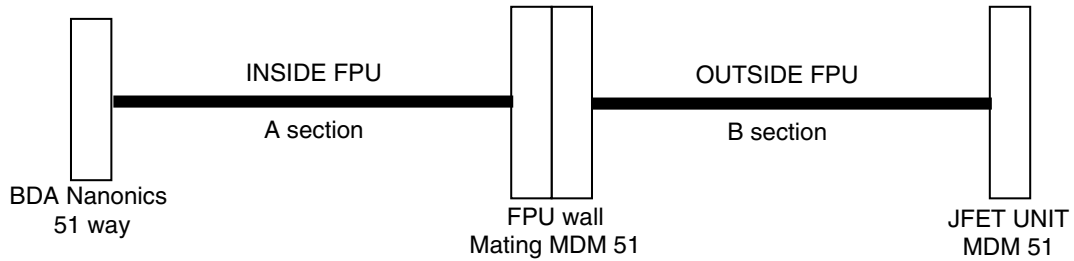

JPL configured Photometer BDA lead, maintaining Faraday cage HSJFP to FPU, and keeping signal ground separate from chassis ground.

### Connector/Backshell Details

**A** section: Nanonics STM50PC2DC012N? to MDM51S mounted in wall

**B** section: MDM51P with XXXX to MDM51S with XXXX at JFET module.

### Harness Layup

**B** section requires outer RF shield, **A** section does not.

**B** section may have thermal heatsink attachments, TBD.

As F1, length a variable

### Contact Details

as F1



# SPIRE HARNES DEFINITION

Doc #: SPIRE-RAL-PRJ-000608  
Issue: 0.7  
Date: 19/09/01  
Page 94 of 136

## 4.4.8 F8[A&B] PMW-B BDA to HSJFP

### Overall Mechanical Drwg.

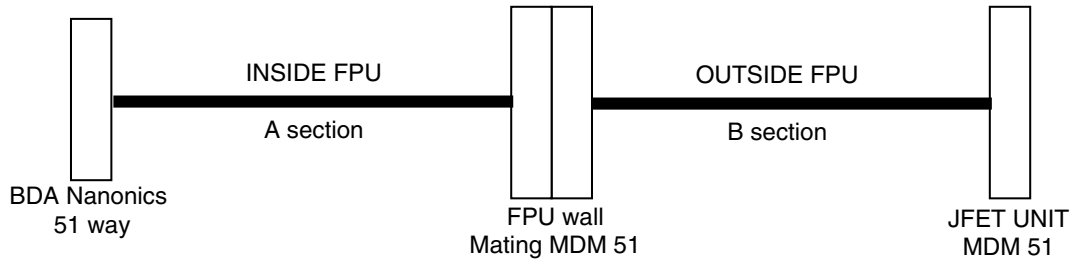

JPL configured Photometer BDA lead, maintaining Faraday cage HSJFP to FPU, and keeping signal ground separate from chassis ground.

### Connector/Backshell Details

**A** section: Nanonics STM50PC2DC012N? to MDM51S mounted in wall

**B** section: MDM51P with XXXX to MDM51S with XXXX at JFET module.

### Harness Layup

**B** section requires outer RF shield, **A** section does not.

**B** section may have thermal heatsink attachments, TBD.

As F1, length a variable

### Contact Details

as F1



# SPIRE HARNES DEFINITION

Doc #: SPIRE-RAL-PRJ-000608  
Issue: 0.7  
Date: 19/09/01  
Page 95 of 136

## 4.4.9 F9[A&B] PMW-D BDA to HSJFP

### Overall Mechanical Drwg.

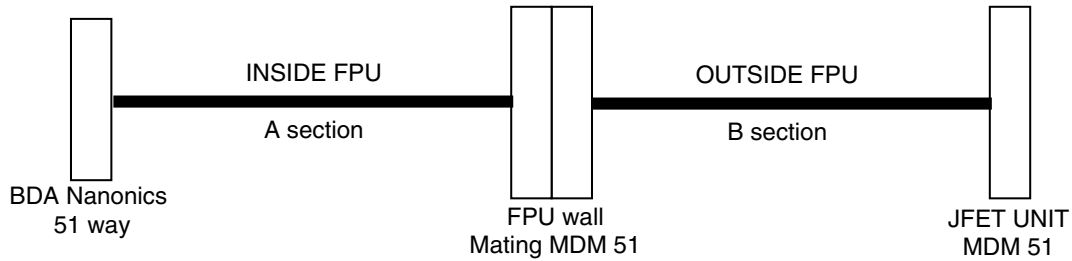

JPL configured Photometer BDA lead, maintaining Faraday cage HSJFP to FPU, and keeping signal ground separate from chassis ground.

### Connector/Backshell Details

**A** section: Nanonics STM50PC2DC012N? to MDM51S mounted in wall

**B** section: MDM51P with XXXX to MDM51S with XXXX at JFET module.

### Harness Layup

**B** section requires outer RF shield, **A** section does not.

**B** section may have thermal heatsink attachments, TBD.

As F1, length a variable

### Contact Details

as F1



# SPIRE HARNES DEFINITION

Doc #: SPIRE-RAL-PRJ-000608  
Issue: 0.7  
Date: 19/09/01  
Page 96 of 136

## 4.4.10 F10[A&B] PMW-D BDA to HSJFP

### Overall Mechanical Drwg.

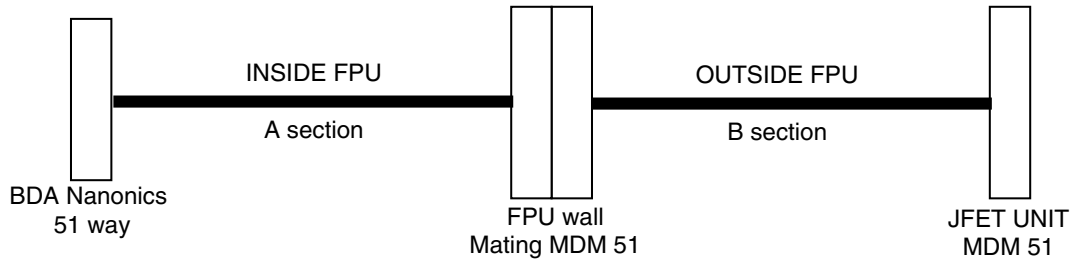

JPL configured Photometer BDA lead, maintaining Faraday cage HSJFP to FPU, and keeping signal ground separate from chassis ground.

### Connector/Backshell Details

**A** section: Nanonics STM50PC2DC012N? to MDM51S mounted in wall

**B** section: MDM51P with XXXX to MDM51S with XXXX at JFET module.

### Harness Layup

**B** section requires outer RF shield, **A** section does not.

**B** section may have thermal heatsink attachments, TBD.

As F1, length a variable

### Contact Details

as F1





# SPIRE HARNES DEFINITION

Doc #: SPIRE-RAL-PRJ-000608  
Issue: 0.7  
Date: 19/09/01  
Page 97 of 136

## 4.4.11 F11[A&B] PLW-A BDA to HSJFP

### Overall Mechanical Drwg.

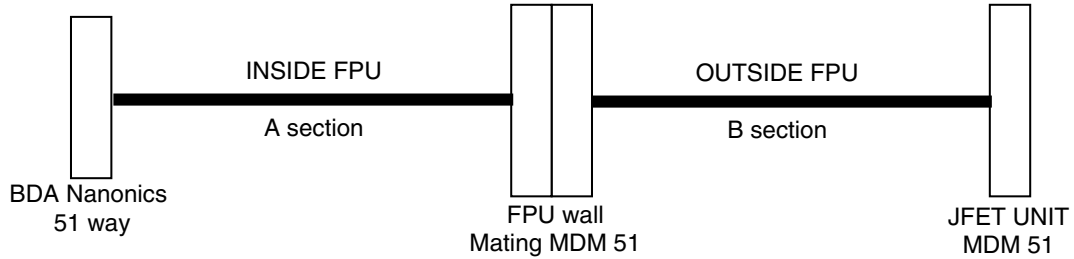

JPL configured Photometer BDA lead, maintaining Faraday cage HSJFP to FPU, and keeping signal ground separate from chassis ground.

### Connector/Backshell Details

**A** section: Nanonics STM50PC2DC012N? to MDM51S mounted in wall

**B** section: MDM51P with XXXX to MDM51S with XXXX at JFET module.

### Harness Layup

**B** section requires outer RF shield, **A** section does not.

**B** section may have thermal heatsink attachments, TBD.

As F1, length a variable

### Contact Details

as F1



# SPIRE HARNES DEFINITION

Doc #: SPIRE-RAL-PRJ-000608  
Issue: 0.7  
Date: 19/09/01  
Page 98 of 136

## 4.4.12 F12[A&B] PLW-B BDA to HSJFP

### Overall Mechanical Drwg.

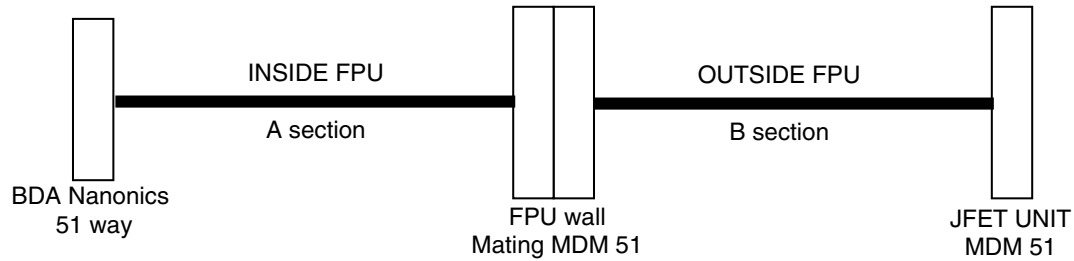

JPL configured Photometer BDA lead, maintaining Faraday cage HSJFP to FPU, and keeping signal ground separate from chassis ground.

### Connector/Backshell Details

**A** section: Nanonics STM50PC2DC012N? to MDM51S mounted in wall

**B** section: MDM51P with XXXX to MDM51S with XXXX at JFET module.

### Harness Layup

**B** section requires outer RF shield, **A** section does not.

**B** section may have thermal heatsink attachments, TBD.

As F1, length a variable

### Contact Details

as F1



# SPIRE HARNES DEFINITION

Doc #: SPIRE-RAL-PRJ-000608  
Issue: 0.7  
Date: 19/09/01  
Page 99 of 136

## 4.4.13 F13[A&B] SSW-A BDA to HSJFS

### Overall Mechanical Drwg.

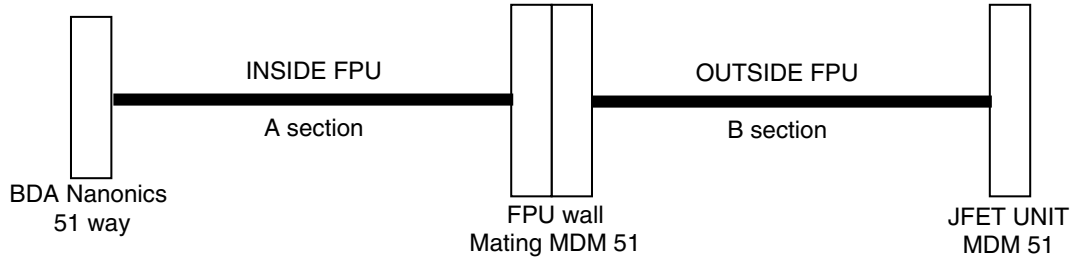

JPL configured Photometer BDA lead, maintaining Faraday cage HSJFP to FPU, and keeping signal ground separate from chassis ground.

### Connector/Backshell Details

**A** section: Nanonics STM50PC2DC012N? to MDM51S mounted in wall

**B** section: MDM51P with XXXX to MDM51S with XXXX at JFET module.

### Harness Layup

**B** section requires outer RF shield, **A** section does not.

**B** section may have thermal heatsink attachments, TBD.

As F1, length a variable

### Contact Details

as F1



# SPIRE HARNES DEFINITION

Doc #: SPIRE-RAL-PRJ-000608  
Issue: 0.7  
Date: 19/09/01  
Page 100 of 136

## 4.4.14 F14[A&B] SSW-B BDA to HSJFS

### Overall Mechanical Drwg.

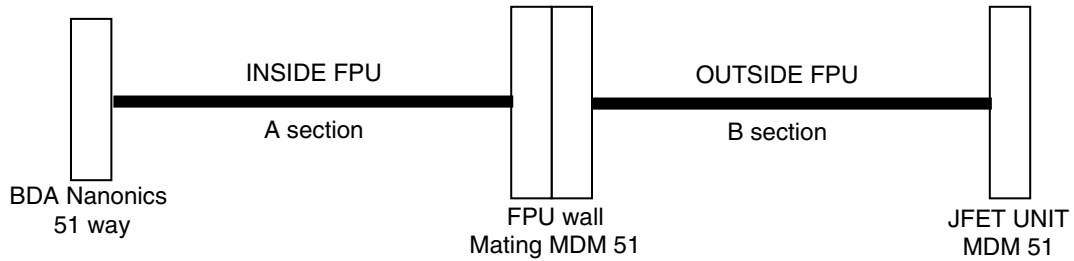

JPL configured Photometer BDA lead, maintaining Faraday cage HSJFP to FPU, and keeping signal ground separate from chassis ground.

### Connector/Backshell Details

**A** section: Nanonics STM50PC2DC012N? to MDM51S mounted in wall

**B** section: MDM51P with XXXX to MDM51S with XXXX at JFET module.

### Harness Layup

**B** section requires outer RF shield, **A** section does not.

**B** section may have thermal heatsink attachments, TBD.

As F1, length a variable

### Contact Details

as F1



# SPIRE HARNES DEFINITION

Doc #: SPIRE-RAL-PRJ-000608  
Issue: 0.7  
Date: 19/09/01  
Page 101 of 136

## 4.4.15 F15[A&B] SLW-A BDA to HSJFS

### Overall Mechanical Drwg.

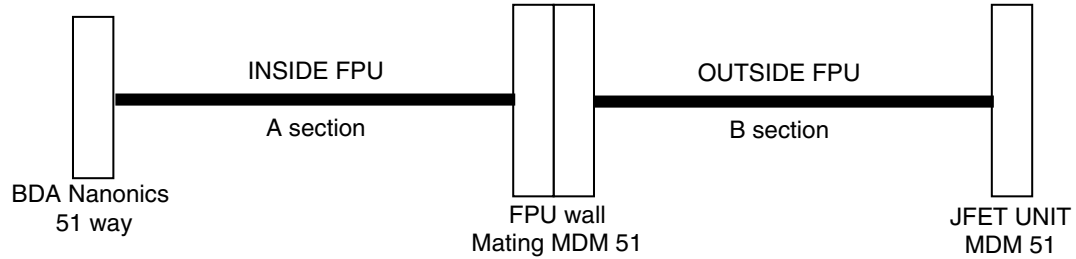

JPL configured Photometer BDA lead, maintaining Faraday cage HSJFP to FPU, and keeping signal ground separate from chassis ground.

### Connector/Backshell Details

**A** section: Nanonics STM50PC2DC012N? to MDM51S mounted in wall

**B** section: MDM51P with XXXX to MDM51S with XXXX at JFET module.

### Harness Layup

**B** section requires outer RF shield, **A** section does not.

**B** section may have thermal heatsink attachments, TBD.

As F1, length a variable

### Contact Details

as F1



# SPIRE HARNES DEFINITION

Doc #: SPIRE-RAL-PRJ-000608  
Issue: 0.7  
Date: 19/09/01  
Page 102 of 136

## 4.4.16 F16 COOLER-P to FA

Overall Mechanical Drwg.

37 way MDM into Cooler prime J1 to 37 way MDM into HSFPU Filter FA J1

Connector/Backshell Details

Harness Layup

As C10 tail layup

Contact Details



# SPIRE HARNES DEFINITION

Doc #: SPIRE-RAL-PRJ-000608  
Issue: 0.7  
Date: 19/09/01  
Page 103 of 136

## 4.4.17 F17 COOLER-R to FA

Overall Mechanical Drwg.

37 MDMway to Cooler redundant to 37 MDMway on HSFPU Filter FD J1

Connector/Backshell Details

Harness Layup

Contact Details



# SPIRE HARNES DEFINITION

Doc #: SPIRE-RAL-PRJ-000608  
Issue: 0.7  
Date: 19/09/01  
Page 104 of 136

## 4.4.18 F18 SPECT\_STIM-P to FA

Overall Mechanical Drwg.

21way MDM to J1 Spectrometer Stim to 37way MDM at J2 on HSFPU Filter FA

Connector/Backshell Details

Harness Layup

Contact Details





# SPIRE HARNES DEFINITION

Doc #: SPIRE-RAL-PRJ-000608  
Issue: 0.7  
Date: 19/09/01  
Page 105 of 136

## 4.4.19 F19 SPECT\_STIM-R to FD

Overall Mechanical Drwg.

21way MDM to J2 Spectrometer Stim to 37way MDM at J2 on HSFPU Filter FD

Connector/Backshell Details

Harness Layup

Contact Details



# SPIRE HARNES DEFINITION

Doc #: SPIRE-RAL-PRJ-000608  
Issue: 0.7  
Date: 19/09/01  
Page 106 of 136

## 4.4.20 F20 THERM-P from FA

Overall Mechanical Drwg.

Multiple TBD to 37way MDM at J1 on HSFPU Filter FB

Connector/Backshell Details

Harness Layup

Contact Details



# SPIRE HARNES DEFINITION

Doc #: SPIRE-RAL-PRJ-000608  
Issue: 0.7  
Date: 19/09/01  
Page 107 of 136

## 4.4.21 F21 THERM-R from FE

Overall Mechanical Drwg.

Multiple TBD to 37way MDM at J1 on HSFPU Filter FE

Connector/Backshell Details

Harness Layup

Contact Details



# SPIRE HARNES DEFINITION

Doc #: SPIRE-RAL-PRJ-000608  
Issue: 0.7  
Date: 19/09/01  
Page 108 of 136

## 4.4.22 F22 BSM-P to FB

Overall Mechanical Drwg.

Connector/Backshell Details

51 MDMway to BSM Prime to 37 MDMway on HSFPU Filter FB J2

Harness Layup

Contact Details



# SPIRE HARNES DEFINITION

Doc #: SPIRE-RAL-PRJ-000608  
Issue: 0.7  
Date: 19/09/01  
Page 109 of 136

## 4.4.23 F23 BSM-R to FE

Overall Mechanical Drwg.

Connector/Backshell Details

51 MDMway to BSM Redundant to 37 MDMway on HSFPU Filter FE J2

Harness Layup

Contact Details



# SPIRE HARNES DEFINITION

Doc #: SPIRE-RAL-PRJ-000608  
Issue: 0.7  
Date: 19/09/01  
Page 110 of 136

## 4.4.24 F24 SMECSIG-P to FC

Overall Mechanical Drwg.

Connector/Backshell Details

37 MDMway to SMEC Signal Prime to 37 MDMway on HSFPU Filter FC J1

Harness Layup

Contact Details



# SPIRE HARNES DEFINITION

Doc #: SPIRE-RAL-PRJ-000608  
Issue: 0.7  
Date: 19/09/01  
Page 111 of 136

## 4.4.25 F25 SCECDRV-P to FC

Overall Mechanical Drwg.

Connector/Backshell Details

37 MDMway to SMEC Drive Prime to 37 MDMway on HSFPU Filter FC J2

Harness Layup

Contact Details



# SPIRE HARNES DEFINITION

Doc #: SPIRE-RAL-PRJ-000608  
Issue: 0.7  
Date: 19/09/01  
Page 112 of 136

## 4.4.26 F26 SMECSIG-R to FF

Overall Mechanical Drwg.

Connector/Backshell Details

37 MDMway to SMEC Signal Redundant to 37 MDMway on HSFPU Filter FF J1

Harness Layup

Contact Details





# SPIRE HARNES DEFINITION

Doc #: SPIRE-RAL-PRJ-000608  
Issue: 0.7  
Date: 19/09/01  
Page 113 of 136

## 4.4.27 F27 SMECDRV-P to FF

Overall Mechanical Drwg.

Connector/Backshell Details

37 MDMway to SMEC Drive Prime to 37 MDMway on HSFPU Filter FF J2

Harness Layup

Contact Details



# SPIRE HARNESSES DEFINITION

Doc #: SPIRE-RAL-PRJ-000608  
Issue: 0.7  
Date: 19/09/01  
Page 114 of 136

## 4.5 JFET unit Back-Harnesses

### 4.5.1 Overview

The Bolometer Back Harness provides the routing of wires from the JFET membrane 15way "service" connectors into the 37way filter units which link them to harnesses C3 and half of C1.

The 15ways each provide 7 double wired functions on 14 pins as follows, all d.c. isolated from ground in the JFET boxes themselves:

Function	A-wire	B-wire	
JFET V-	1	8	These colour codes are carried through to the drawing below
JFET V +	10	14	
JFET Vgnd	9	15	
Bias +	2	7	
Bias -	4	5	
Heater +	3	6	Values agree with
Heater -	11	13	30/7/01 JPL review

Basically the back harness is 1:1 pinned, not in the sense of numbering but in that of in-wiring splices. Actually, for the photometer, the 4 x 37 = 148 filter contacts cannot accommodate all the 12 x 14 = 168 contacts from the JFET boxes, but some splicing is not really a problem in a copper-based harness that does not span temperature differentials. However not all the total of 148 + [3 x 14] = 190 wires entering the 37 way filters can proceed through the 150 ways available in harnesses C3 and half of C1, not least because without introducing in-line jumpers in the filter units (a potential failure point) some contacts are used as terminations for shields on C1 and C3. Appropriate commoning is done by wire links in the 37way units, which means that there are often options for linking up JFET Vgnd.

There remains no splicing in the C or I series cryoharnesses.

Looking at the table above\*, note that the A and B wires for each of these functions must be linked in the HSDCU to maintain cryoharness robustness against single wire breakage, *whether or not* they then split into two again and feed into Prime and Redundant DCU electronics functions. The reasons that A and B wires do not follow each other in the same harness tail and get linked inside the harness itself at the warm end are both that mechanical distress to the cryoharness is likely to be on a tail-by-tail (connector-by-connector) basis and one does not want both the A and B wires of any function broken, and that they ate bundled close together anyway to minimise loop areas.

\*Strictly speaking this paragraph applies to the grouped functions that get through the 37way linking, but it remains true for any particular BDA looking into the wiring.

The philosophy of deciding which how to common up the a.c. bias generators was decided in issue 0.3 of this document with a view to failure control. If the supposedly impossible happened and both the A and B wires of a particular function were to break, that function should not take out a complete BDA array. This is accomplished on 4 BDAs by allocating them more than a single function, whilst on the 5<sup>th</sup>, the small SLW BDA there is enough spare pin capacity to double up the wiring again. This provides the HSDCU with as many separately wired a.c. bias generator wires as can be fitted through the harnesses C/I3 and half of C/I1. Apart from the required linking of A and B wires as mentioned above, it is then a matter of on-going detailed design for HSDCU reliability that determines any further grouping or splitting.

In changing back to 37way filters for the JFET functions there is the beneficial side effect that far more of the BS and BF harness wires can be accommodated directly on to contacts, minimising splices in these harnesses. It can be seen that splices are essentially restricted to the JFET heater wires, with just a few still needed for the bias distribution. It is however flagged that JPL have still to confirm pin arrangements for Thermal Control biases that are fed in with the PMW detectors (presumably one MDM enlarged from 15 ways will handle back-harness, bias input and wires to the sensors).



# SPIRE HARNESS DEFINITION

Doc #: SPIRE-RAL-PRJ-000608  
Issue: 0.7  
Date: 19/09/01  
Page 115 of 136

14 wires, colour coded  
as in table above leave each  
JFET module  
A-wires are drawn out. B-wires  
are identical and feed from  
here into other half of SF and  
into SP2

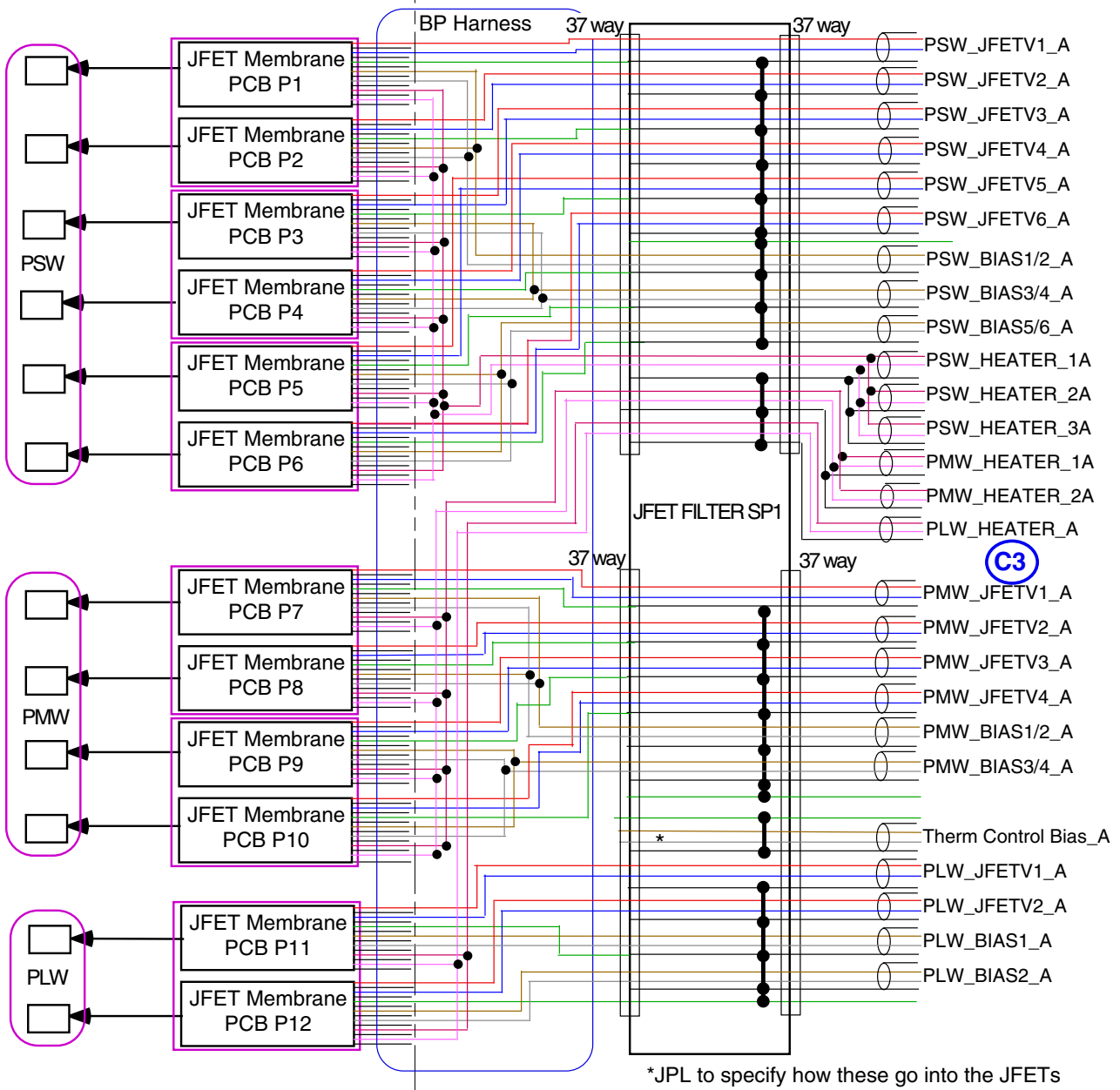
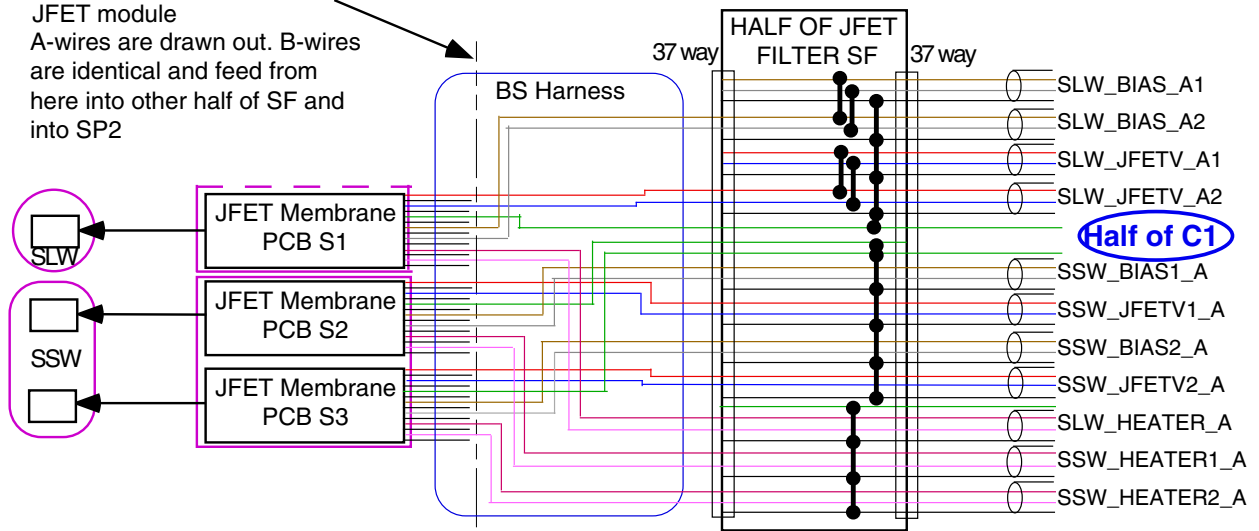



# SPIRE HARNESS DEFINITION

Doc #: SPIRE-RAL-PRJ-000608  
Issue: 0.7  
Date: 19/09/01  
Page 116 of 136

## 4.5.2 BP-Photometer

### Overall Mechanical Drwg.

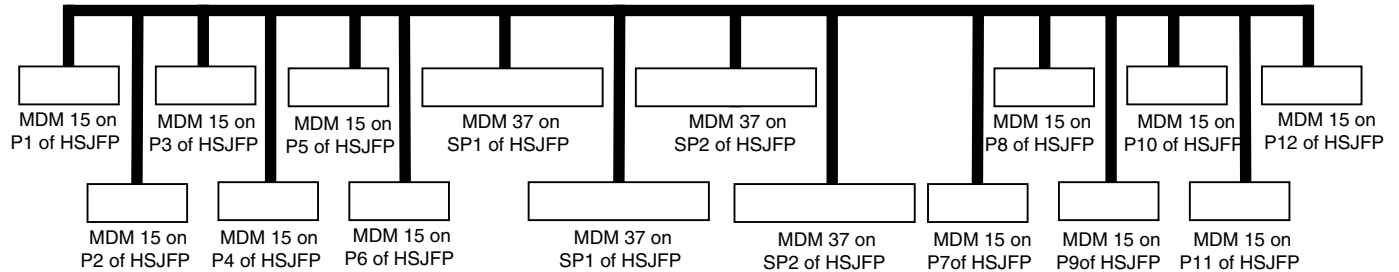

### Connector/Backshell Details

JPL to specify.

### Harness Layup

The BS harness is all at one temperature. Crimped 28AWG copper MDM?

Pairs of wires should at least be twisted, and some inter-function screens may be appropriate, JPL to specify.

The whole harness must be very well RF screened to all its backshells: not only does it form part of a Faraday cage but it forms part of one that is on the detector side of the Murata filter system.

This is definitely a harness to build on a dimensionally accurate horse!





# SPIRE HARNES DEFINITION

Doc #: SPIRE-RAL-PRJ-000608  
 Issue: 0.7  
 Date: 19/09/01  
 Page 118 of 136

Name	SP1A 87way	SP1B 87way	SP2A 87way	SP2B 87way	P1 15 way	P2 15 way	P3 15 way	P4 15 way	P5 15 way	P6 15 way	P7 15way	P8 15way	P9 15way	P10 15way	P11 15way	P12 15way
Harness Shield Link		NC														
THERM_GND_WIRE_A		11														
THERM_CONTROL_BIAS_A_+		12														
THERM_CONTROL_BIAS_A-		30														
THERM_CONTROL_BIAS_A shld		31														
PLW_JFETV1_A_+		13													1	
PLW_JFETV1_A-		32													10	
PLW_JFETV1_A shld		15														
PLW_JFETV2_A_+		33														1
PLW_JFETV2_A-		15														10
PLW_JFETV2_A shld		34														
PLW_BIAS1_A_+		16													2	
PLW_BIAS1_A-		36													4	
PLW_BIAS1_A shld		17													9	
PLW_BIAS2_A_+		37														2
PLW_BIAS2_A-		18														4
PLW_BIAS2_A shld		37														
PLW_A_GND_WIRE		19														9
PSW_JFETV1_B_+			20		8											
PSW_JFETV1_B-			2		14											
PSW_JFETV1_B shld			1		15											
PSW_JFETV2_B_+			3			8										
PSW_JFETV2_B-			22			14										
PSW_JFETV2_B shld			21													
PSW_JFETV3_B_+			23				8									
PSW_JFETV3_B-			4				14									
PSW_JFETV3_B shld			5			15										
PSW_JFETV4_B_+			6					8								
PSW_JFETV4_B-			25					14								
PSW_JFETV4_B shld			24													
PSW_JFETV5_B_+			26						8							
PSW_JFETV5_B-			8						14							
PSW_JFETV5_B shld			7				15									
PSW_JFETV6_B_+			9							8						
PSW_JFETV6_B-			28							14						
PSW_JFETV6_B shld			27													
PSW_GRND_B			10													
PSW_BIAS1/2_B_+			11		7	7										
PSW_BIAS1/2_B-			29		5	5										
PSW_BIAS1/2_B shld			30					15								
PSW_BIAS3/4_B_+			31				7	7								
PSW_BIAS3/4_B-			12				5	5								
PSW_BIAS3/4_B shld			13						15							
PSW_BIAS5/6_B_+			14						7	7						
PSW_BIAS5/6_B-			32						5	5						
PSW_BIAS5/6_B shld			33							15						
PSW_HEATER_B_+x3			34		6	6	6	6	6	6						
PSW_HEATER_B_-x3			15		13	13	13	13	13	13						
PSW_HEATER_B shldx3			16													
PMW_HEATER_B_+x2			17								6	6	6	6		
PMW_HEATER_B_-x2			35								13	13	13	13		
PMW_HEATER_B shldx2			36													
PLW_HEATER_B_+			37												6	6
PLW_HEATER_B-			18												13	13
PLW_HEATER_B shld			19													
PMW_JFETV1_B_+				20							8					
PMW_JFETV1_B-				2							14					





# SPIRE HARNES DEFINITION

Doc #: SPIRE-RAL-PRJ-000608  
 Issue: 0.7  
 Date: 19/09/01  
 Page 120 of 136

## 4.5.3 BS-Spectrometer

### Overall Mechanical Drwg.

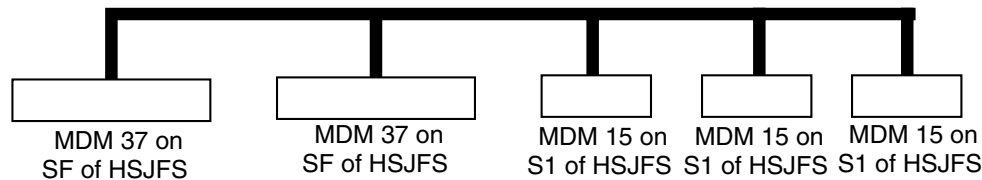

### Connector/Backshell Details

JPL to specify.

### Harness Layup

The BS harness is all at one temperature. Crimped 28AWG copper MDM?

Pairs of wires should at least be twisted, and some inter-function screens may be appropriate, JPL to specify.

The whole harness must be very well RF screened to all its backshells: not only does it form part of a Faraday cage but it forms part of one that is on the detector side of the Murata filter system.

### Contact Details

Function	HSJFS 37wayA	HSJFS 37wayA	SLW PCBS1 15way	SSW PCBS2 15way	SSW PCBS3 15way
SLW_BIAS_A1+ve	20		2		
SLW_BIAS_A1-ve	2		4		
SLW_Grnd_A	1				
SLW_BIAS_A2 +ve	3		2		
SLW_BIAS_A2 -ve	22		4		
SLW_Grnd_A	21				
SLW_JFETV_A1 +ve	23		1		
SLW_JFETV_A1 -ve	5		10		
SLW_Grnd_A	4				
SLW_JFETV_A2 +ve	6		1		
SLW_JFETV_A2 -ve	25		10		
SLW_Grnd_A	24				
SLW_Grnd_A	7		9		
SSW_Grnd_A	26			9	
SSW_Grnd_A	8				9
SSW_BIAS1_A +ve	9			2	
SSW_BIAS1_A -ve	28			4	
SSW_Grnd_A	27				
SSW_JFETV1_A +ve	29			1	
SSW_JFETV1_A -ve	11			10	
SSW_J Grnd_A	10				
SSW_BIAS2_A +ve	12				2
SSW_BIAS2_A -ve	31				4





# SPIRE HARNES DEFINITION

Doc #: SPIRE-RAL-PRJ-000608  
 Issue: 0.7  
 Date: 19/09/01  
 Page 121 of 136

Function	HSJFS 37wayA	HSJFS 37wayA	SLW PCBS1 15way	SSW PCBS2 15way	SSW PCBS3 15way
SSW_Grnd_A	30				
SSW_JFETV2_A +ve	32				1
SSW_JFETV2_A -ve	14				10
SSW_Grnd_A	13				
S_Heater_Grnd	33				
SLW_HEATER_A +ve	34		3		
SLW_HEATER_A -ve	16		11		
S_Heater_Grnd_A	15				
SSW_HEATER1_A +ve	17			3	
SSW_HEATER1_A -ve	36			11	
S_Heater_Grnd_A	35				
SSW_HEATER2_A +ve	37				3
SSW_HEATER2_A -ve	19				11
S_Heater_Grnd_A	18				
SLW_BIAS_B1+ve		20	7		
SLW_BIAS_B1-ve		2	5		
SLW_Grnd_B		1			
SLW_BIAS_B2 +ve		3	7		
SLW_BIAS_B2 -ve		22	5		
SLW_Grnd_B		21			
SLW_JFETV_B1 +ve		23	8		
SLW_JFETV_B1 -ve		5	14		
SLW_Grnd_B		4			
SLW_JFETV_B2 +ve		6	8		
SLW_JFETV_B2 -ve		25	14		
SLW_Grnd_B		24			
SLW_Grnd_B		7	15		
SSW_Grnd_B		26		15	
SSW_Grnd_B		8			15
SSW_BIAS1_B +ve		9		7	
SSW_BIAS1_B -ve		28		5	
SSW_Grnd_B		27			
SSW_JFETV1_B +ve		29		8	
SSW_JFETV1_B -ve		11		14	
SSW_J Grnd_B		10			
SSW_BIAS2_B +ve		12			7
SSW_BIAS2_B -ve		31			5
SSW_Grnd_B		30			
SSW_JFETV2_B +ve		32			8
SSW_JFETV2_B -ve		14			14
SSW_Grnd_B		13			
S_Heater_Grnd		33			
SLW_HEATER_B +ve		34	6		
SLW_HEATER_B -ve		16	13		
S_Heater_Grnd_B		15			
SSW_HEATER1_B +ve		17		6	
SSW_HEATER1_B -ve		36		13	
S_Heater_Grnd_B		35			
SSW_HEATER2_B +ve		37			6
SSW_HEATER2_B -ve		19			13
S_Heater_Grnd_B		18			



# SPIRE HARNES DEFINITION

Doc #: SPIRE-RAL-PRJ-000608  
Issue: 0.7  
Date: 19/09/01  
Page 122 of 136

## 4.6 Test Harnesses

### 4.6.1 T1 Primary 1553 Bus + Clock

Overall Mechanical Drwg.

1:1

Connector/Backshell Details

To HSDPU J3 and J5

Harness Layup

Contact Details

As per SPIRE-RAL-COM-000562 Iss2

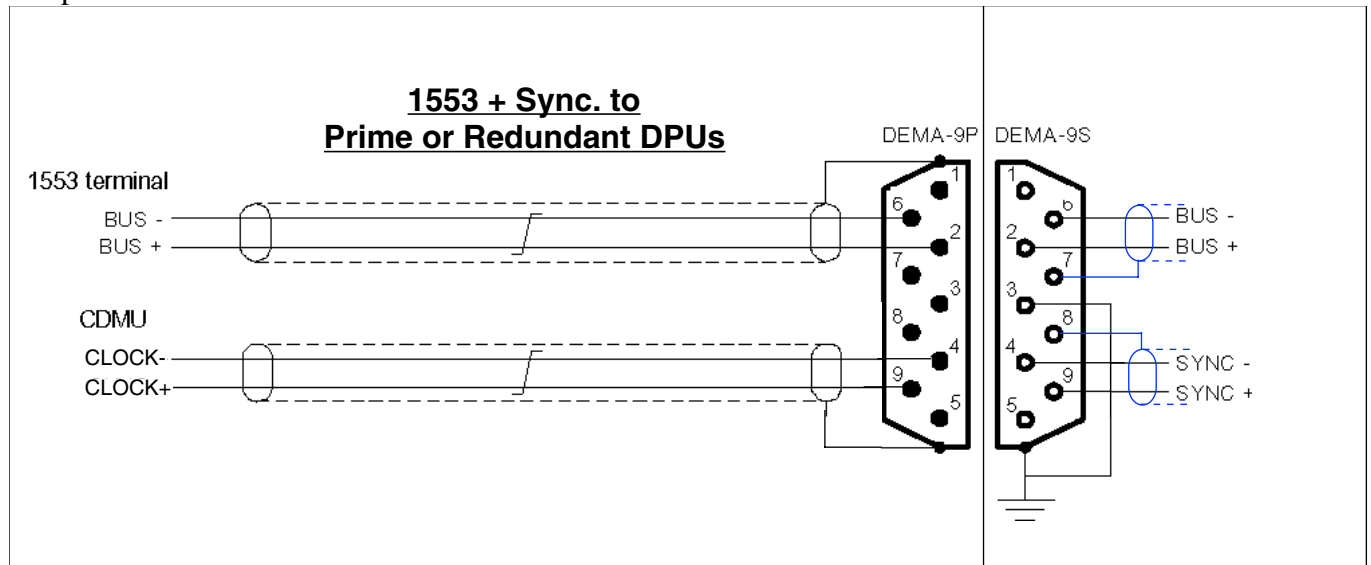



# SPIRE HARNES DEFINITION

Doc #: SPIRE-RAL-PRJ-000608  
Issue: 0.7  
Date: 19/09/01  
Page 123 of 136

## 4.6.2 T2 Secondary 1553 Bus + Clock

Overall Mechanical Drwg.

1:2

Connector/Backshell Details

To HSDPU J4 and J6

Harness Layup

Contact Details

As per SPIRE-RAL-COM-000562 Iss2

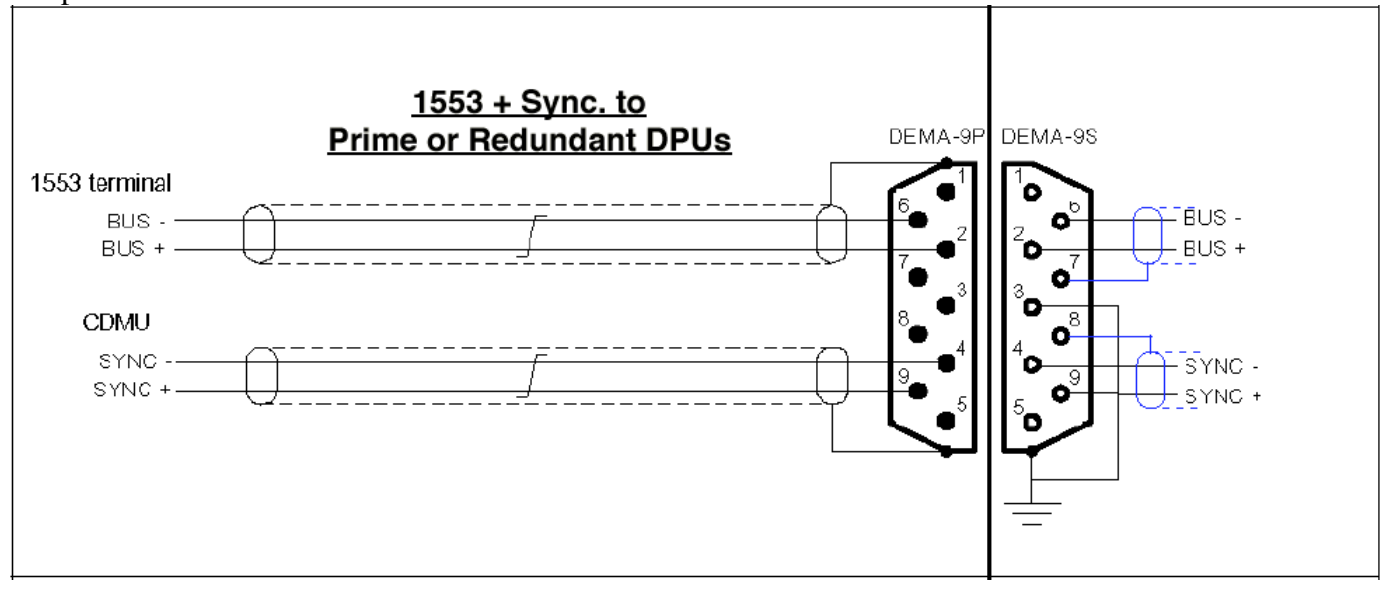



# SPIRE HARNES DEFINITION

Doc #: SPIRE-RAL-PRJ-000608  
Issue: 0.7  
Date: 19/09/01  
Page 124 of 136

## 4.6.3 T3 DPU-P Power

Overall Mechanical Drwg.

Connector/Backshell Details

To HSDPU J1

Harness Layup

Contact Details

As per SPIRE-RAL-COM-000562 Iss2

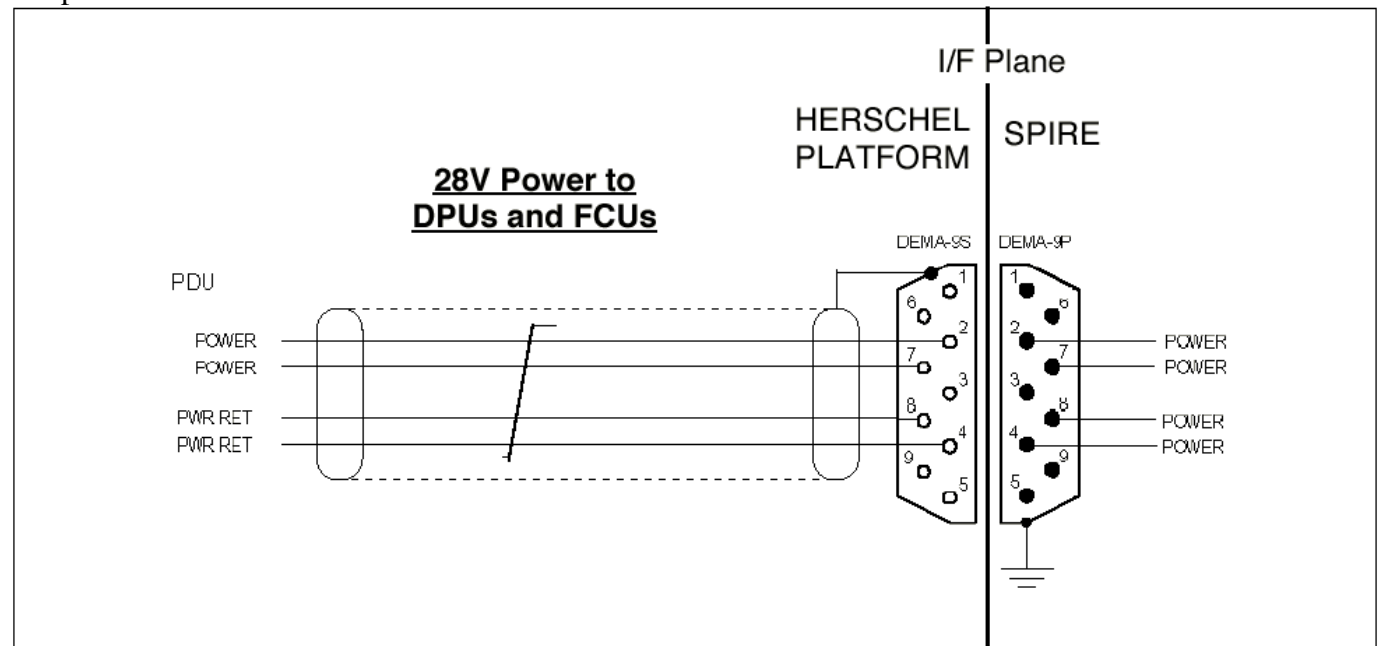



# SPIRE HARNES DEFINITION

Doc #: SPIRE-RAL-PRJ-000608  
Issue: 0.7  
Date: 19/09/01  
Page 125 of 136

## 4.6.4 T4 DPU-R Power

Overall Mechanical Drwg.

Connector/Backshell Details

To HSDPU J2

Harness Layup

Contact Details

As per SPIRE-RAL-COM-000562 Iss2

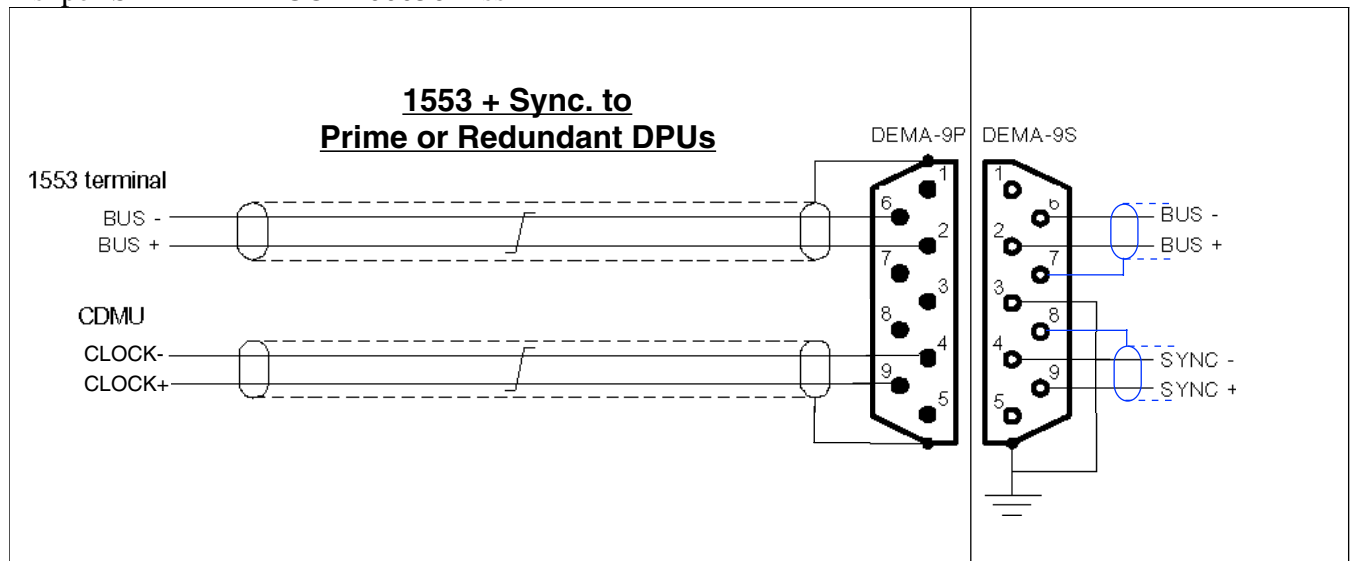



# SPIRE HARNES DEFINITION

Doc #: SPIRE-RAL-PRJ-000608  
Issue: 0.7  
Date: 19/09/01  
Page 126 of 136

## 4.6.5 T5 FCU-P Power

Overall Mechanical Drwg.

1:1

Connector/Backshell Details

To HSFCU J5

Harness Layup

Contact Details

As per SPIRE-RAL-COM-000562 Iss2

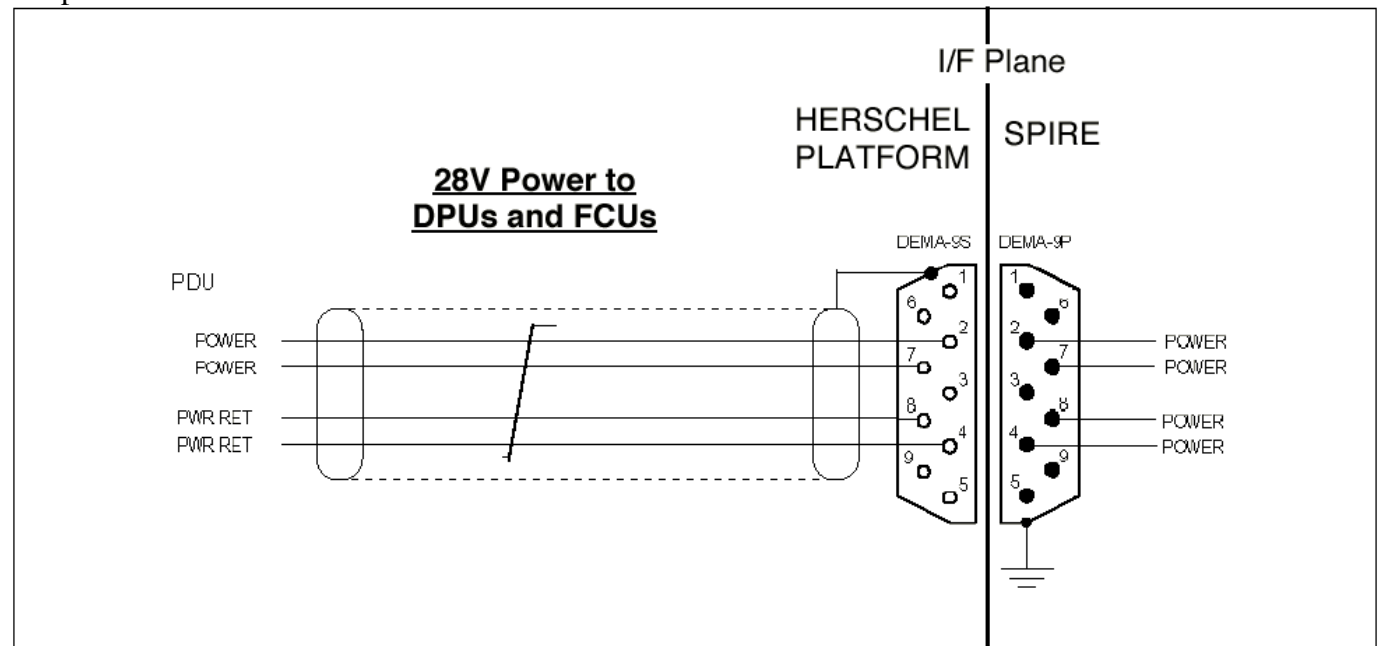



# SPIRE HARNES DEFINITION

Doc #: SPIRE-RAL-PRJ-000608  
Issue: 0.7  
Date: 19/09/01  
Page 127 of 136

## 4.6.6 T6 FCU-R Power

Overall Mechanical Drwg.

1:1

Connector/Backshell Details

To HSFCU J6

Harness Layup

Contact Details

As per SPIRE-RAL-COM-000562 Iss2

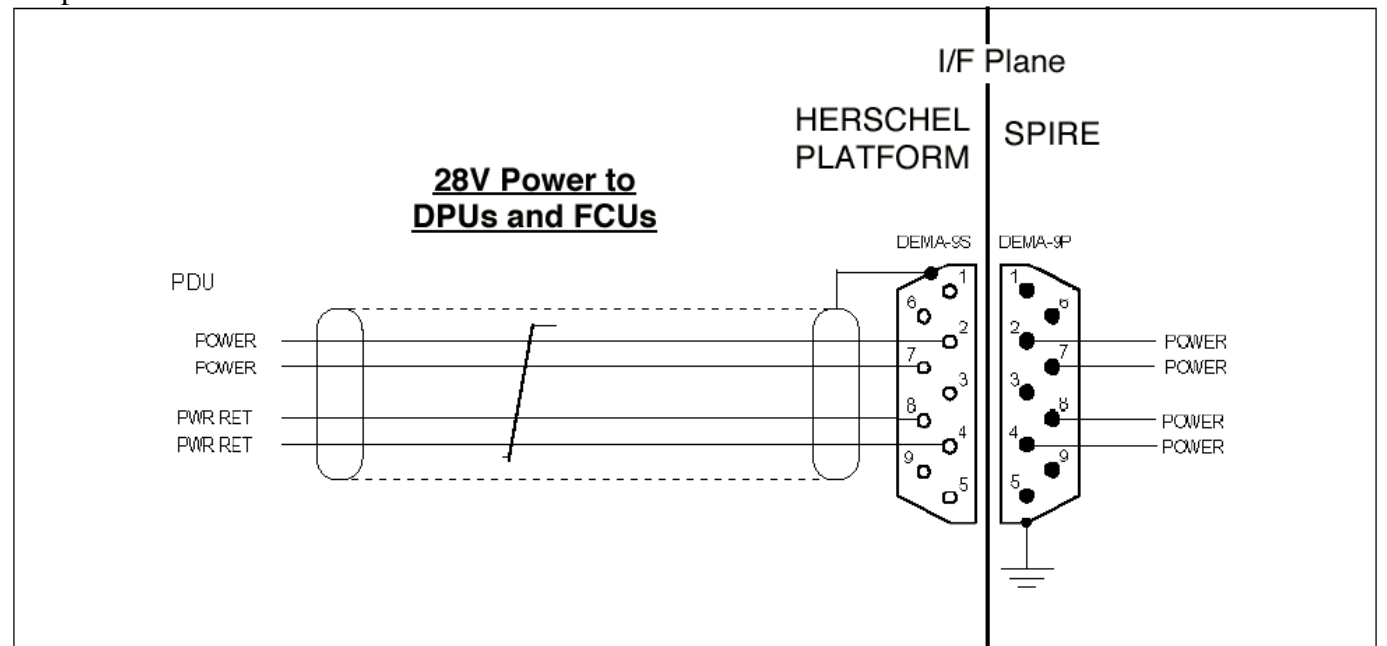



# SPIRE HARNESS DEFINITION

Doc #: SPIRE-RAL-PRJ-000608  
Issue: 0.7  
Date: 19/09/01  
Page 128 of 136

## 4.6.7 T7 SHT via FCU-P

Overall Mechanical Drwg.

Connector/Backshell Details

Harness Layup

Contact Details





# SPIRE HARNES DEFINITION

Doc #: SPIRE-RAL-PRJ-000608  
Issue: 0.7  
Date: 19/09/01  
Page 129 of 136

## 4.6.8 T8 SHT via FCU-R

Overall Mechanical Drwg.

Connector/Backshell Details

Harness Layup

Contact Details





# SPIRE HARNES DEFINITION

Doc #: SPIRE-RAL-PRJ-000608  
Issue: 0.7  
Date: 19/09/01  
Page 131 of 136

Name	100 Way Connector	FPU/JFS/JFP Connector	C Harness Connector Type	Description	Number of Conductors excl. shlds	Number of inner Shields	Type	Max. Impedance		Max Current per Conductor	Average Current	Duty Cycle		Max. Volts	
								R (W)	C (pF)			L (uH)	t		T (t x T)
<b>C11 Drive-P</b>				300mK Thermal Control Heater	4	1	STQ	30		100uA		50%	33%	17%	
		FPU J17	MDM15P	Actuator position sense + Latch Confirm	4	1	STQ	1000		?		0%	0%	0%	10
				Latch+solenoid drives and vane heater	4	1	STQ	10		100mA		0%	0%	0%	
				Vane thermistor bias and readout	4	1	STQ	1000		1uA		0%	0%	0%	
				RF Overshield sealed to both backshells		Outer	>93%		0.01						no
		CVW 11	FPU J25	BSM Chopper Sensors	5	2	STT+P	1000		250nA		100%	33%	33%	0.4
				BSM Jiggle Sensors	5	2	STT+P	1000		1uA		100%	33%	33%	
				BSM Temperature	4	1	STQ	1000		1uA		100%	33%	33%	
				Photometer Stimulus Heater	4	1	STQ	10		7mA		5%	33%	2%	
				BSM Launch latch sense	2	1	STP	1000		0		0%	0%	0%	
<b>C12 Aux-R</b>				BSM Launch latch sense	3	1	STT	10		35mA		0%	0%	0%	
				BSM Launch latch solenoid	4	1	STQ	10		40mA		0%	0%	0%	
				BSM Chop motor drive	4	1	STQ	10		40mA		0%	0%	0%	
				BSM Jiggle motor drive	4	1	STQ	10		40mA		0%	0%	0%	
				SMEC Thermometry	8	2	STQ	1000		1uA		100%	33%	33%	
				SMEC LVDT Primary	2	1	STP	500		5mA		50%	33%	17%	5
				SMEC LVDT Secondary	4	2	STP	500		50uA		50%	33%	17%	15
				SMEC Launch Latch1	4	2	STP	10		0		0%	0%	0%	15
				SMEC Launch Latch1 Confirm	2	1	STP	100		1mA		0%	0%	0%	15
				SMEC Launch Latch2	4	2	STP	10		0		0%	0%	0%	15
<b>C13 Drive-R</b>				SMEC Launch Latch2 Confirm	2	1	STP	100		400mA/50mS		0%	0%	0%	15
				SMEC Drive Coil	4	2	STP	5		1mA		0%	0%	0%	15
				SMEC Drive coil voltage sensor	2	1	STP	500		10uA		0%	33%	17%	15
				SMEC Position sensor supplies	4	2	STP	100		10uA		0%	33%	17%	5
				SMEC Position sensor photodiodes	6	3	STP	1000		20uA		50%	33%	17%	5
				SMEC Position sensor photodiodes FB	6	3	STP	1000		10uA		50%	33%	17%	5
				RF Overshield sealed to both backshells		Outer	>93%		0.01						no
		CVW 12	FPU J20	Sorption Pump Heater	4	0	TQ	10		25mA		6%	33%	2%	
				Heat switch heaters	8	0	TQ	50		1.5mA		100%	33%	33%	
	<b>C13 Drive-R</b>				Various cooler thermistors	20	5	STQ	1000		1uA		100%	33%	33%
				Spectrometer Stimulus Thermistors	12	3	STQ	1000		1uA		100%	33%	33%	
				Spectrometer Stimulus Heater 4%	4	0	TQ	30		9mA		100%	33%	33%	4
				Spectrometer Stimulus Heater 2%	4	0	TQ	30		7mA		50%	33%	17%	
				FPU Thermometry	24	6	STQ	1000		1uA		100%	33%	33%	
				300mK Thermal Control Heater	4	1	STQ	300		1uA		100%	33%	33%	
				Actuator position sense + Latch Confirm	4	1	STQ	1000		?		50%	33%	17%	
				Latch+solenoid drives and vane heater	4	1	STQ	1000		100mA		0%	0%	0%	10
				Vane thermistor bias and readout	4	1	STQ	10		100mA		0%	0%	0%	
				RF Overshield sealed to both backshells		Outer	>93%		0.01						no
<b>C13 Drive-R</b>				BSM Chopper Sensors	5	2	STT+P	1000		250nA		100%	33%	33%	0.4
				BSM Jiggle Sensors	5	2	STT+P	1000		1uA		100%	33%	33%	
				BSM Temperature	4	1	STQ	1000		1uA		100%	33%	33%	
				Photometer Stimulus Heater	4	1	STQ	1000		7mA		5%	33%	2%	
				BSM Launch latch sense	2	1	STP	1000		0		0%	0%	0%	
				BSM Launch latch solenoid	3	1	STT	10		35mA		0%	0%	0%	
				BSM Chop motor drive	4	1	STQ	10		40mA		0%	0%	0%	
				BSM Jiggle motor drive	4	1	STQ	10		40mA		0%	0%	0%	
				SMEC Thermometry	8	2	STQ	1000		1uA		100%	33%	33%	
				SMEC LVDT Primary	2	1	STP	500		5mA		50%	33%	17%	5
<b>C13 Drive-R</b>				SMEC LVDT Secondary	4	2	STP	500		50uA		50%	33%	17%	15
				SMEC Launch Latch1	4	2	STP	10		0		0%	0%	0%	15
				SMEC Launch Latch1 Confirm	2	1	STP	100		0		0%	0%	0%	15
				SMEC Launch Latch2	4	2	STP	100		0		0%	0%	0%	15
				SMEC Launch Latch2 Confirm	2	1	STP	100		0		0%	0%	0%	15
				SMEC Drive Coil	4	2	STP	5		100mA		50%	33%	17%	15
				SMEC Drive coil voltage sensor	2	1	STP	500		10uA		0%	33%	17%	15
				SMEC Position sensor supplies	4	2	STP	100		10uA		50%	33%	17%	5
				SMEC Position sensor photodiodes	6	3	STP	1000		20uA		50%	33%	17%	5
				SMEC Position sensor photodiodes FB	6	3	STP	1000		10uA		50%	33%	17%	5
			RF Overshield sealed to both backshells		Outer	>93%		0.01						no	



# SPIRE HARNES DEFINITION

Doc #: SPIRE-RAL-PRJ-000608  
Issue: 0.7  
Date: 19/09/01  
Page 132 of 136

Name	100 Way Connector	SVM Connector	I Harness Connector Type	Description	Number of Conductors excl. shlds	Number of inner Shields	Type	R (W)	C(pF)	L(uH)	Max.Current per Conductor	Average t	Duty Cycle T	(t x T)	Max. Volts
<b>I1</b> Type3	CVV 1	DCU J27	DCMA37 S	12 ch. SLW Bolometer(1-12) Ground Wire	24	12	STP	100	1500	0.12	1nA	50%	33%	17%	0.1
		DCU J28	DCMA37 S	12 ch. SLW Bolometer(13-24) Ground Wire	24	0	STP	100	1500	0.12	1nA	50%	33%	17%	0.1
		DCU J33	DCMA37P	Spectrometer Bias (SLW & SSW) JFET Power Heaters (SLW and SSW)	8	4	STP	1000	1500	0.12	1mA	50%	33%	17%	0.1
		DCU J34	DCMA37P	Ground wires Spectrometer Bias (SLW & SSW) JFET Power Heaters (SLW and SSW)	8	4	STP	100	1500	0.12	5mA	50%	33%	17%	0.1
<b>I2</b> Type4	CVV 2	DCU J23	DCMA37 S	RF Overshield insulated from CVV wall 12 ch. SSW Bolometer (1-12) Ground Wire	24	12	STP	200	1500	0.12	1nA	50%	33%	17%	0.1
		DCU J24	DCMA37 S	Ground Wire 12 ch. SSW Bolometer (13-24) Ground Wire	24	0	STP	1000	1500	0.12	1nA	50%	33%	17%	0.1
		DCU J25	DCMA37 S	Ground Wire 12 ch. SSW Bolometer (25-36) Ground Wires	24	12	STP	200	1500	0.12	1nA	50%	33%	17%	0.1
		DCU J26	DCMA37 S	Ground Wires 12 ch. SSW Bolometer (37-48 inc.spares)	24	12	STP	200	1500	0.12	1nA	50%	33%	17%	0.1
<b>I3</b> Type2	CVV 3	DCU J29	DCMA37P	Ground Wires RF Overshield insulated from CVV wall PSW JFET Power PSW Bias Heaters	12	6	STP	100	1500	0.12	5mA	50%	33%	17%	0.1
		DCU J31	DCMA37P	Ground Wire PMW/PLW JFET Power PMW/PLW Bias Temp. Control Bias	12	6	STP	1000	1500	0.12	5mA	50%	33%	17%	0.1
		DCU J30	DCMA37P	Ground Wire PSW JFET Power PSW Bias Heaters	12	6	STP	100	1500	0.12	5mA	50%	33%	17%	0.1
		DCU J32	DCMA37P	Ground Wire PMW/PLW JFET Power PMW/PLW Bias Temp. Control Bias Ground Wire	12	6	STP	1000	1500	0.12	5mA	50%	33%	17%	0.1
<b>I4</b> Type1	CVV 4	DCU J20	DDMA 50S	RF Overshield insulated from CVV wall 16 ch. PMW (1-16) Ground Wire	32	16	STP	100	1500	0.12	1nA	50%	33%	17%	0.1
		DCU J21	DDMA 50S	Ground Wire 16 ch. PMW (17-32) Ground Wire	32	16	STP	100	1500	0.12	1nA	50%	33%	17%	0.1
		DCU J22	DDMA 50S	Ground Wire 16 ch. PMW (33-48) Ground Wire	32	16	STP	100	1500	0.12	1nA	50%	33%	17%	0.1
		DCU J17	DDMA 50S	RF Overshield insulated from CVV wall 16 ch. PMW (1-16) Ground Wire	32	16	STP	100	1500	0.12	1nA	50%	33%	17%	0.1
<b>I5</b> Type1	CVV 5	DCU J18	DDMA 50S	Ground Wire 16 ch. PMW (17-32)	32	16	STP	100	1500	0.12	1nA	50%	33%	17%	0.1
		DCU J18	DDMA 50S	Ground Wire 16 ch. PMW (17-32)	32	16	STP	100	1500	0.12	1nA	50%	33%	17%	0.1



# SPIRE HARNES DEFINITION

Doc #: SPIRE-RAL-PRJ-000608  
Issue: 0.7  
Date: 19/09/01  
Page 133 of 136

Name	100 Way Connector	SVM Connector	I Harness Connector Type	Description	Number of Conductors excl. shlds	Number of inner Shields	Type	R (W)	Max. Impedance C(pF)	L(uH)	Max.Current per Conductor	Average	t	Duty Cycle T	(t x T)	Max. Volts		
<b>I6 Type1</b>	CVV 6	Shield	DCU J19	Ground Wire	2	0	Single	1000	1500	0.12	1nA		50%	33%	17%	0.1		
			DCU J14	16 ch. PMW (33-48)	32	16	STP	100	1500	0.12	1nA							
	CVV 7	Shield	DCU J15	Ground Wire	2	0	Single	1000	1500	0.12	0.01	1nA		50%	33%	17%	0.1	
			DCU J16	RF Overshield insulated from CVV wall	32	16	STP	100	1500	0.12	1nA							
			DCU J11	16 ch. PMW (1-16)	32	16	STP	1000	1500	0.12	1nA							
			DCU J12	Ground Wire	32	16	STP	100	1500	0.12	1nA							
<b>I7 Type1</b>	CVV 8	Shield	DCU J13	16 ch. PMW (17-32)	32	16	STP	1000	1500	0.12	1nA		50%	33%	17%	0.1		
			DCU J10	Ground Wire	32	16	STP	100	1500	0.12	1nA							
			DCU J8	RF Overshield insulated from CVV wall	32	16	STP	1000	1500	0.12	1nA							
			DCU J9	16 ch. PMW (1-16)	32	16	STP	100	1500	0.12	1nA							
			DCU J7	Ground Wire	32	16	STP	1000	1500	0.12	1nA							
			DCU J6	16 ch. PMW (33-48)	32	16	STP	100	1500	0.12	1nA							
<b>I8 Type1</b>	CVV 9	Shield	DCU J15	RF Overshield insulated from CVV wall	32	16	STP	1000	1500	0.12	1nA		50%	33%	17%	0.1		
			DCU J5	16 ch. PMW (1-16)	32	16	STP	100	1500	0.12	1nA							
			DCU J6	Ground Wire	32	16	STP	1000	1500	0.12	1nA							
			DCU J7	16 ch. PMW (17-32)	32	16	STP	100	1500	0.12	1nA							
			DCU J10	Ground Wire	32	16	STP	1000	1500	0.12	1nA							
			DCU J9	16 ch. PMW (33-48)	32	16	STP	100	1500	0.12	1nA							
<b>I9 Type1</b>	CVV 10	Shield	FCU J15	RF Overshield insulated from CVV wall	4	1	STQ	1000	1000	0.01	?		0%	0%	0%	10		
			FCU J11	Actuator position sense + Latch Confirm	4	1	STQ	10	10		100mA							
			FCU J11	Latch-solenoid drives and vane heater	4	1	STQ	1000	1000		1mA							
			FCU J13	Vane thermistor bias and readout	4	0	TQ	10	10		25mA	0.12						
			FCU J23	Cooler heaters	4	0	TQ	50	50		1.5mA	0.12						
			FCU J25	Sorption pump heat switch heaters	8	0	TQ	30	30		1.5mA	0.12						
<b>I10 Aux-P</b>	CVV 11	Shield	FCU J23	Evaporator heat switch heaters	4	0	TQ	50	50		1µA		100%	33.30%	33%	0.4		
			FCU J25	Spectrometer Stimulator Heater Drives	32	8	STQ	1000	1000		9mA	0.12						
			FCU J25	FPU Thermometry A	4	1	STQ	30	30		1µA	0.12						
			FCU J21	300mK Thermal Control Heater	28	7	STQ	1000	1000		100µA	0.12						
			FCU J19	FPU Thermometry B	12	3	STQ	1000	1000		1µA	0.01						
			FCU J19	FPU Thermometry C	4	0	TQ	10	10		1µA	0.12						
<b>I11 Drive-P</b>	CVV 11	Shield	MDM 37P	RF Overshield insulated from CVV wall	5	2	STT+P	1000	1000		250nA		100%	33%	33%	0.4		
			MDM 37P	Photometer Stimulus Heater	5	2	STT+P	1000	1000		1µA							
			MDM 37P	BSM Chopper Sensors	4	0	STQ	10	10		7mA							
			MDM 37P	BSM Jiggle Sensors	2	1	STP	1000	1000		5mA							
			MDM 37P	Photometer Stimulus Heater	3	1	STT	10	10		0							
			MDM 37P	BSM Launch latch sense	3	1	STT	10	10		35mA							



# SPIRE HARNES DEFINITION

Doc #: SPIRE-RAL-PRJ-000608  
Issue: 0.7  
Date: 19/09/01  
Page 134 of 136

Name	100 Way Connector	SVM Connector	I Harness Connector Type	Description	Number of Conductors excl. shlds	Number of inner Shields	Type	R (W)	Max. Impedance C(pF)	L(uH)	Max Current per Conductor	Average	t	Duty Cycle T	(t x T)	Max. Volts		
<b>I12 Aux-R</b>	CVV 12	Shield	FCU J16	BSM Chop motor drive	4	1	STQ	10			40mA		0%	0%	0%	0		
				BSM Jiggle motor drive	4	1	STQ	10					40mA		0%	0%	0%	0
				SMEC LVDT Primary	2	1	STP	500			5mA			5mA	50%	33%	17%	0
				SMEC LVDT Secondary	4	2	STP	500			50µA			50µA	50%	33%	17%	0
				SMEC Launch Latch1	4	2	STP	10			400mA/50mS			0	0%	0%	0%	0
				SMEC Launch Latch1 Confirm	2	1	STP	100			1mA			0	0%	0%	0%	0
				SMEC Launch Latch2	4	2	STP	10			400mA/50mS			0	0%	0%	0%	0
				SMEC Launch Latch2 Confirm	2	1	STP	100			1mA			0	0%	0%	0%	0
				SMEC Drive Coil	4	2	STP	5			100mA			8mA	50%	33%	17%	0
				SMEC Drive coil voltage sensor	2	1	STP	500			10µA			10µA	0%	33%	0%	0
				SMEC Position sensor supplies	4	2	STP	100			1mA			1mA	50%	33%	17%	0
				SMEC Position sensor photodiodes	6	3	STP	1000			20µA			20µA	50%	33%	17%	0
SMEC Position sensor photodiodes FB	6	3	STP	1000			10µA			10µA	50%	33%	17%	0				
RF Overshield sealed to both backshells						Outer	>93%			0.01								
Actuator position sense + Latch Confirm	4	1	STQ	1000			100mA				100mA	0%	0%	0%	0			
Latch+solenoid drives and vane heater	4	1	STQ	10			10			1mA	1mA	0%	0%	0%	0			
Vane thermistor bias and readout	4	0	TQ	10			10			25mA	1mA	6%	1/3	2%	0			
Cooler heaters	4	0	TQ	50			50			1.5mA	100%	100%	1/3	33%	0			
Sorption pump heat switch heaters	4	0	TQ	50			50			1.5mA	100%	33.30%	33%	33%	0			
Evaporator heat switch heaters	4	0	TQ	30			30			9mA	50%	33%	33%	17%	0			
Spectrometer Stimulator Heater Drives	8	0	TQ	30			30			9mA	50%	33%	33%	17%	0			
FPU Thermometry A	32	8	STQ	1000			1000			1µA	100%	100%	33%	33%	0			
300mK Thermal Control Heater	4	1	STQ	30			30			100µA	50%	33%	33%	17%	0			
FPU Thermometry B	28	7	STQ	1000			1000			1µA	100%	100%	33%	33%	0			
RF Overshield insulated from CVV wall		self					>93%			0.01								
FPU Thermometry C	12	3	STQ	1000			1000			0.12	1µA	1µA	100%	33%	33%	0.4		
Photometer Stimulus Heater	4	0	TQ	10			10			7mA	1µA	1µA	100%	33%	33%	0.4		
BSM Chopper Sensors	5	2	STT+P	1000			1000			250nA	250nA	100%	33%	33%	0			
BSM Jiggle Sensors	5	2	STT+P	1000			1000			1µA	1µA	100%	33%	33%	0			
Photometer Stimulus Heater	4	0	STQ	10			10			7mA	5mA	5%	33%	2%	0			
BSM Launch latch sense	2	1	STP	1000			1000				0	0%	0%	0%	0			
BSM Launch latch solenoid	3	1	STT	10			10			35mA	0	0%	0%	0%	0			
BSM Chop motor drive	4	1	STQ	10			10			40mA	0	0%	0%	0%	0			
BSM Jiggle motor drive	4	1	STQ	10			10			40mA	0	0%	0%	0%	0			
SMEC LVDT Primary	2	1	STP	500			500			5mA	5mA	50%	33%	17%	5			
SMEC LVDT Secondary	4	2	STP	500			500			50µA	50µA	50%	33%	17%	5			
SMEC Launch Latch1	4	2	STP	10			10			0	0	0%	0%	0%	15			
SMEC Launch Latch1 Confirm	2	1	STP	100			100			1mA	0	0%	0%	0%	15			
SMEC Launch Latch2	4	2	STP	10			10			0	0	0%	0%	0%	15			
SMEC Launch Latch2 Confirm	2	1	STP	100			100			1mA	0	0%	0%	0%	15			
SMEC Drive Coil	4	2	STP	5			5			100mA	8mA	50%	33%	17%	15			
SMEC Drive coil voltage sensor	2	1	STP	500			500			10µA	10µA	0%	33%	0%	15			
SMEC Position sensor supplies	4	2	STP	100			100			1mA	1mA	50%	33%	17%	15			
SMEC Position sensor photodiodes	6	3	STP	1000			1000			20µA	20µA	50%	33%	17%	5			
SMEC Position sensor photodiodes FB	6	3	STP	1000			1000			10µA	10µA	50%	33%	17%	5			
RF Overshield sealed to both backshells						Outer	>93%			0.01								



# SPIRE HARNESSES DEFINITION

Doc #: SPIRE-RAL-PRJ-000608  
Issue: 0.7  
Date: 19/09/01  
Page 135 of 136

## BDA Channels

### CROSS-REFERENCE OF SPIRE CHANNELS TO HARNESSES NAMES

Most of this information can be worked out by following the Spire block diagram but it is included here for ease of reference.

BDA	PLW		PMW				PSW						SLW	SSW	
JPL BDA #	10209800-1		10209800-2				10209800-3						1...00-4	10209800-5	
C/I Harness	6		5		4		9		8		7		half 1	2	
Nanonics #															
Channel	J05	J06	J01	J02	J03	J04	J01	J02	J03	J04	J05	J06	J05	J05	J06
A	1	25	1	25	49	73	1	25	49	73	97	121	1	1	25
B	2	26	2	26	50	74	2	26	50	74	98	122	2	2	26
C	3	27	3	27	51	75	3	27	51	75	99	123	3	3	27
D	4	28	4	28	52	76	4	28	52	76	100	124	4	4	28
E	5	29	5	29	53	77	5	29	53	77	101	125	5	5	29
F	6	30	6	30	54	78	6	30	54	78	102	126	6	6	30
G	7	31	7	31	55	79	7	31	55	79	103	127	7	7	31
H	8	32	8	32	56	80	8	32	56	80	104	128	8	8	32
I	9	33	9	33	57	81	9	33	57	81	105	129	9	9	33
J	10	34	10	34	58	82	10	34	58	82	106	130	10	10	34
K	11	35	11	35	59	83	11	35	59	83	107	131	11	11	35
L	12	36	12	36	60	84	12	36	60	84	108	132	12	12	36
M	13	37	13	37	61	85	13	37	61	85	109	133	13	13	37
N	14	38	14	38	62	86	14	38	62	86	110	134	14	14	38
P	15	39	15	39	63	87	15	39	63	87	111	135	15	15	39
R	16	40	16	40	64	88	16	40	64	88	112	136	16	16	40
S	17	41	17	41	65	89	17	41	65	89	113	137	17	17	41
T	18	42	18	42	66	90	18	42	66	90	114	138	18	18	42
U	19	43	19	43	67	91	19	43	67	91	115	139	19	19	43
V	20	44	20	44	68	92	20	44	68	92	116	140	20	20	44
W	21	45	21	45	69	93	21	45	69	93	117	141	21	21	45
X	22	46	22	46	70	94	22	46	70	94	118	142	22	22	46
Y	23	47	23	47	71	95	23	47	71	95	119	143	23	23	47
Z	24	48	24	48	72	96	24	48	72	96	120	144	24	24	48

Within the C/I harness listings, channel numbers are shown in modulo 48

## Addendum: What is 12-ax?

This cableform is maybe not self-explanatory in the same way as the others in this document. A rather specific format of 12-ax is intended.

It is drawn in diagrams as:

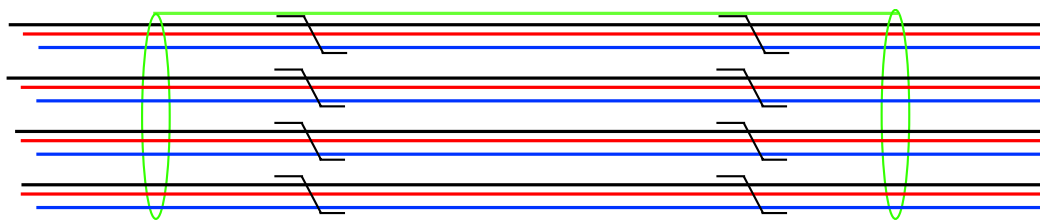

This consists of 4 twisted triples, each triple being three insulated multicore wires, inside one braided shield, all inside an outer insulator.

The material, identified by JPL, uses stainless steel for all conductors, nominally 38AWG.

Using the black wires as screens for twisted pairs (red and blue), capacitance and thermal conductivity are low compared to four screened twisted pairs and cross-talk is apparently acceptable.

Note that the outer screen is also quite light-weight, and for this reason it is not used as the main RF shield on harnesses in Spire.





# SPIRE HARNES DEFINITION

Doc #: SPIRE-RAL-PRJ-000608  
Issue: 0.7  
Date: 19/09/01  
Page 136 of 136

## Spire Grounding Diagram

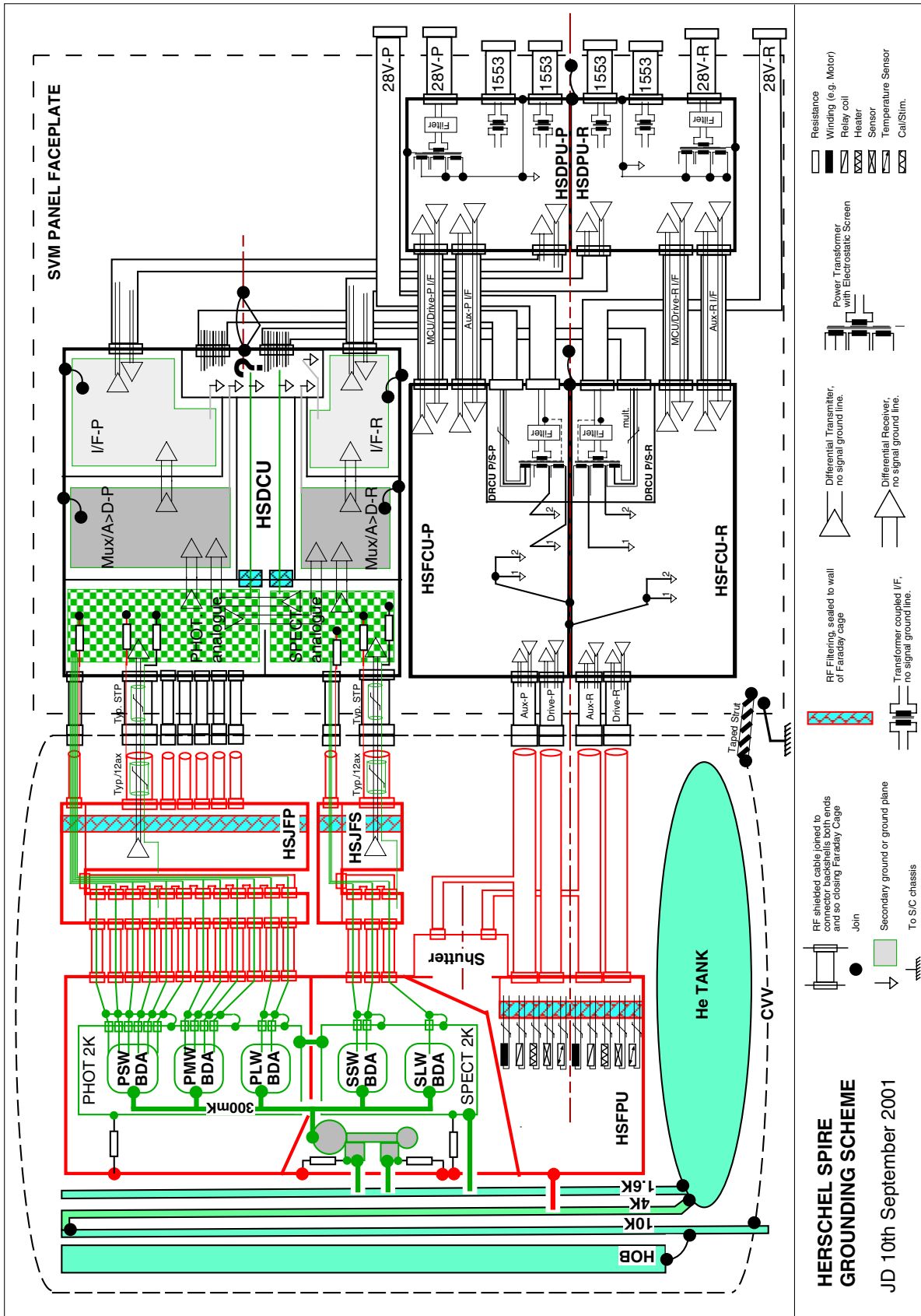

End of Doc.