

Subject: HERSCHEL SPIRE HARNESS DEFINITION

- This issue is consistent with the SPIRE Block Diagram Issue 5.8 - Issued 11 May 2004
- This issue is consistent with the SPIRE Grounding and Screening Philosophy – Issue 1.0, October 2002.

PREPARED BY:	D.K. Griffin _____	SPIRE SYSTEMS ENGINEER	RAL	Date: _____
APPROVED BY:	J. Delderfield _____	SPIRE SYSTEMS ENGINEER	RAL	Date: _____
APPROVED BY:	K. King _____	SPIRE Project Manager	RAL	Date: _____
AGREED BY:	M. Herman _____	Herschel/Plank PM	JPL	Date: _____

CHANGE RECORD

ISSUE	DATE	SECTION	CHANGE(S) MADE
Draft 0.1	28/3/01	All	First Issue
Draft 0.2	11/4/01	All	Still getting it together! No unified style for lists yet.
Draft 0.3	10/5/01	Section 3	Update diagrams to fit latest SPIRE block diagram
		W1-6	Clarify screens as per communication 26/4/01, leaving other pins unchanged.
		C&I 1&3	Update Type 2 and Type 3 harnesses to fit 1:1 to membranes' back harness contacts, using 25pin filters.
		C Type1s	Simplify by carrying signal ground on screens.
		I1	Remove nasty 3 row double density 44 way connectors
		All Cs	Put in JFET and FET filter designations
		I1 Type3	Nasty 44 pin 3row DCU connectors removed.
		C10-C13	Add tail wiring details. omitting FCU pin details until unit layout confirmed. Changed HSFCU J21 and J22 to 15 way because don't need more pins.
Draft 0.4	10/8/01	Section 3	Update diagrams to fit SPIRE block diagram iss. 2.5. This uses 37way not 25way BDA service filter modules.
		BP & BS	Include JFET unit Back-Harnesses as separate section, in order to control all major SPIRE harnesses herein. Move overview of them from section 3 into this new one.
		I11&I13	Change HSFCU J21 and J22 back to 25way because do actually need more pins...stimulator heater omitted in iss0.3!
		F1-15	Make clear has plug/socket at HSFPU wall [A & B]
		C1-13	Ensure harness outer shields inside the cryostat include a break and do not unchangeably join the 100Way CVV connector bodies to the HSFPU/HSJFP/HSJFS backshells. Linking them is a left-over from when these units and the 300mK plumbing were all fixed grounded to the cryostat. Shields inside the cryostat now come through 100way pins, reducing their availability for use as signal grounds. The harness is now compatible with the SPIRE grounding scheme in which either the cryogenic or the warm end of the bolometer analogue system can be joined to chassis ground.
		Acronym	List inserted.
		Wiring list	Append as Annex. This will be included in the IID-B but IS NOT a sufficient specification for the C/I harnesses
		C1 and C3	In draft 0.2 fixed on 12ax for C harnesses inside cryostat where practical to minimise heatleak with screened twisted pairs used on I harnesses outside where RF fields may be larger. Switch to screened twisted pairs on bias lines in C1 and C3 to improve screening at JPL's request, but taking this as OK because they are only small proportion of the overall wires.
C1 and C3	JFET membrane heater wires sized same as combined JFET voltage supply wires because power needs to be the same and heaters will now be sized to make their voltages similar		
Draft 0.4 contd.	10/8/01	C1-2 & C4-9	Show 12ax third wires as joined to ground pin at 25way MDMs and not just at the 100way CVV connectors, to reduce ground noise.
		C1 and I1	Remove 300mK Thermal Control Thermistor a.c. Biasing from Spectrometer side harness.
		I11 & I13	BSM temp. removed from BSM tail listing as is already in temperature sensors' tail
		T Harnesses	Update Harness drawing etc. to remove "sync": from S/C to HSDRCU and to split EGSE units.
		C/I 10 & 12	Remove JFET box thermistors included in error. Affects DCU J23 and J24 + FCU J23 and J24. Permits cleaner shield to 100way pin allocations.
		C/I 10 & 12	Change to updated Spectrometer Calibrator Wiring.
		C3	Alter multiple heater wires to be in same proportions as multiplicity of JFET



SPIRE HARNESS DEFINITION DOCUMENT

Doc: SPIRE-RAL-PRJ-000608
Issue: 1.2
Date: 17/02/05
Page 3 of 245

ISSUE	DATE	SECTION	CHANGE(S) MADE
			modules they heat, rather than the reverse! This arrangement is a bit of a left-over from using I2-ax for this harness, and may disappear in the next issue.
0.5	22/8/01	Appendix	Include Channel # cross-reference listing.
		C4	Remove notes on tail connector PCB tracking.
		F1-15	Include pinouts
		C/I 11&13	Adjust launch latch wires as requested.
0.6	15/09/01	C/I 11&13	Update based on SMEC lists "010906.doc"
		Section 3	Update harness layout with new SMEC FCU connectors
		At end	Append grounding diagram as agreed.
		Annex	Put SMEC updates into wiring list.
		C1/3+Annex	Sort out sexes of RF filters so all the same as C11/13
		C/I 11&13	Make BSM latch drive wire resistance same as SMEC's
0.7	19/09/01	All	Get HOB and SOB sorted
			Change Spectrometer Stim temperature to be Flange, not "near SOB"
0.8	02/11/01	4.3.4	Spelling error corrected
		N.A.	Added paragraph numbering to Annexes.
		All	References to the 100-way CVV connectors changed to 128-way
		All	References to "CVV Harness shield link" changed to "FPU Faraday Shield link"
		4.2.4	Colours updated on Type 1 DCU tails harness layout
		4.2.4	Type-1 128-way pin allocations assigned
		I and C	The pin allocations to the 128-way CVV connectors were added.
		I10	J11 and 12 tails amended to incorporate J13 and J14
		I10	Thermal control heater moved from J23 and J24 to J11 and J12
		I11	Split 25way tail to J21 to 15way J21 and 9-way J13.
		I13	Split 25way tail to J22 to 15way J22 and 9-way J14.
		Section 4.5.1	Simplify backharness to remove cross-linking and route temperature control via spare HSJFS membrane.
		BS and BP	Work through changes implied by section 4.5.1.
		C1 & C4	Work through changes implied by section 4.5.1.
		Section 3	Update harness layouts to match issue 0.8 changes.
		F28	Insert section for new harness
		I1 and I3	Insert a note, explaining configuration.
		All	Added backshell numbers.
		T7 and T8	Inserted J27 and J28 pinouts
		T1 and T2	Correct connector content as Sync is long gone.
		C2	Added extra tail for the 300-mK Thermometer signals
		Annex	Added information about the configuration of the CVV backshells
		4.2.10 - I10	Added 128-Way pin assignments to Shutter Table
		4.2.10 - I10	Assigned 128-way pins
		4.3.10 - C10	Added 128-Way pin assignments to Shutter Table
		4.3.10 - C10	Assigned 128-way pins
		4.2.10-I10	Added FPU Faraday Shield Link to harness in J23
		4.2.10-I10	Removed commoning of shields in thermometry tails at 128-way
		4.2.11-I11	Phot Stim. Heater changed to STQ as per C11 and J13 Pin allocation changed
		4.2.11/4.3.11	Chop Motor Pin allocation corrected to be Jiggle Motor
		4.2.2/4.3.2	Changed allocations of pins to accommodate a FPU Shield Link on the I2 harnesses.
		4.2.3	Added extra PMW heater so that each JFET module has a A/B heater lines. Updated pin allocation accordingly.
		Scope	Added note regarding EMI Backshells



SPIRE HARNESS DEFINITION DOCUMENT

Doc: SPIRE-RAL-PRJ-000608
Issue: 1.2
Date: 17/02/05
Page 4 of 245

ISSUE	DATE	SECTION	CHANGE(S) MADE
		4.2.3-I3	Removed discussion notes
		4.6.1	Discussion updated
0.8 Rev A	12/12/01	Annexes 1 & 2	Wiring lists brought into line with issue 0.8.
0.9	1/1/02	Cover	Update summary notes (JD)
		Section 3	Bring figures into line with SPIRE Block Diagram 3.8 (JD)
		W3-6	Swop J1-4 to agree with HSFCU numbering (JD)
		I10-13	Update warm end tail connector splitout to HSFCU design (JD)
		I11 & 13	Fix duplicate use of pin 31 on J17 and J18! (JD)
		I10	Update FCU J23-26 to Christophe's pinout. (JD)
		J37	Put in J37 pinout, removing wires from other I11 tails (JD)
	4/2/02	I1	
		Acronym list	Updated
		Notes	Clarify wording
		I1-I13	Corrected statement on the figures illustrating the D-Sub pin allocations indicating that overshield was not connected to an EMC backshell connector at wall of the CVV.
		I1	Updated Figure to show the ground reference for the FJET heaters to pass through the CVV connector
		I1	Updated figure to indicate commoning of ground references within connectors in the harness.
		I1	Connector names corrected on 128-way pin allocation figure
		I1-I13	Pin allocation tables corrected and notes added.
		I1	Spectrometer Heater ground reference wire deleted from pin allocation table.
		I1	Order of the pin allocation table adjusted to correspond to the order shown in the tail drawings
		I3	Reallocated pins for two 78-way connectors on DCU. (Previously four 37-way)
		W1-W6	Bring into line with DRCU ICD
			Added SPIRE Block diagram as a Reference Document
			Incorporated the connector panel into the cryoharness. This split the "I-Harness" section of the cryoharness into the "E-Harness" running from the wall of the CVV to the SVM connector panel and the "I-Harness" running from the SVM connector panel to the DRCU.
		C2/I2/I4	Incorporated provision for reading out the 300-mK thermal control hardware.
		2.1	The SPIRE Block Diagram called up as a reference document
		W1-W6	Discrepancies between this document and the DRCU and DPU ICDs reconciled. (regarding the harnesses carrying the LSLs and FSDLs)
		Annex 6	SPIRE Instrument Grounding Diagram amended
		Annex 7	Wiring diagram for readout of the 300-mK TC added
		W7/W8	Added pin allocations as per DRCU ICD 1.1
		All	Revised and updated part numbers for Backshells (see notes 7 and 8 in §3-Introduction)
		I1	Corrected labelling of tails on 128-Way
		I1	Moved ground pins of the two bolometer tails on the 128-Way so they are close to each other to facilitate their interconnection
		I4	Connected all ground pins together as indicated.
		I4	Reallocated pins to connector to reflect the incorporation of the 300-mK TC. There are three less signal pairs passing through the 128-Way here.
		I10/I2	Updated tail listing to reflect the incorporation of the 50-way connector for Thermometry Tail A (J23)
		I10/I12	Updated to reflect the incorporation of the skin connector for routing of the Shutter



SPIRE HARNESS DEFINITION DOCUMENT

Doc: SPIRE-RAL-PRJ-000608
Issue: 1.2
Date: 17/02/05
Page 5 of 245

ISSUE	DATE	SECTION	CHANGE(S) MADE
			EGSE
		I10/I12	Updated SMEC I/F to conform to DRCU ICD
		I11	Rearranged pin assignments on the 128-way to allow for the addition of a dedicated launch lock confirmation tail
		C1	Ground pins associated with JFS J5/J6 moved to be adjacent to each other to facilitate the interconnection of the ground pins
		C2	JFS J7 Moved 12-ax cable to centre of connector and grounded un-used signal triplet
		C2	JFS J1 Moved the pair of 12-ax to the centre of the connector
		C2	Added 5MΩ resistor to 300-mK harness as per SPIRE Block Diagram
		C3	Added drawing of 128-Way pin assignments
		C3	Corrected erroneous reference to PSW Bias in listing table
		C4	Corrected error in ground pin assignment on 128-Way
		C10/C12	Changed FPU J17/J18 to MDM 21 S and rearranged harness to conform to this. (including reallocation of the 128-Way)
		C10/C12	Changed pin allocations to FPU J27/J28/J29/J30 to bring into line with LAM design
		C11/C13	Provision for two SMEC launch latches incorporated
		C11/C13	Launch latches for BSM and SMEC rearranged on the 128-Way so that they are adjacent to each other to enable a single tail to be made from them
		C11/C13	Corrected BSM Launch Latch drive to be STP
0.9	15/3/02	I	Issued
	19/04/02	All	Cryoharness nomenclature updated to reflect the convention as used on Herschel. <ul style="list-style-type: none"> • WE to SVM CB = S Harness (in issue 0.9 this was the I Harness) • SVM CB to CVV Wall = I Harness (in issue 0.9 this was the E Harness) • CVV Wall to Cold Units = C Harness
	07/05/02	W1-W6	Corrected pin 14 name. From C SHD to C CMD SHD
	14/05/02	F1-F16, F28	<ul style="list-style-type: none"> • Updated configuration of the BDA-JFET harnesses to indicate feedthrus instead of bulkhead connectors • Corrected sequencing of the harnesses • Corrected MDM51 Pin Allocation table to conform to JPL Wiring Schematic (Corrected U- and Y-)
		F2, F3, F4, F5, F6	Deleted description and referred to §4.5.1
		F1-F16, F28	Corrected connector gender of 51-way JFET MDM
		F1-F16, F28	Corrected information about backshells.
		F8	Deleted description and referred to §4.5.7
		F10, F11, F12	Deleted description and referred to §4.5.9
		F14	Deleted description and referred to §4.5.13
		W3, W4, W5, W6	Changed paragraph title to include both unit name and sub-unit name. (i.e. HSMCU changed to HSFCU (MCU) and HSSCU changed to HSFCU (SCU))
	15/05/02	All	Revised backshells. Updated notes 7 and 8 in the Introduction to reflect current design
	16/05/02	All	Added notes to Socket D-Connectors to indicate that the drawings indicate show the non-engaging face view.
		S2/S4	Moved inline connector (previously un-named) to the SVM-CB. Connector on S2 named JE and mating connector on S4 named PE.
		S/I/C Mechanical Drawings	Updated
		All	Removed any distinction between Flight and Ground Test configurations of the harnesses.



SPIRE HARNESS DEFINITION DOCUMENT

Doc: SPIRE-RAL-PRJ-000608
Issue: 1.2
Date: 17/02/05
Page 6 of 245

ISSUE	DATE	SECTION	CHANGE(S) MADE
		S2/S4/Acronym List	Added Acronym PTC (Photometer Thermal Control) to refer to the 300-mK thermal control system.
		S2 Listing	Updated listing of the PTC
		I11	Corrected drawing of P23 to indicate a Socket gender
		S1-S13	Corrected statements about this harness connecting to the CVV. It now connects to the SVM-CB.
		S10 and S12	Shutter EGSE connector on SVM is no longer D-Sub but Circular bayonette. Pin allocation is TBD. Connector is mounted on SVM-CB
		S11 and S13	Mechanisms launch latch sense connector on SVM is no longer D-Sub but Circular bayonette. Pin allocation is TBD. Connector is mounted on SVM-CB
		All	Ambiguity concerning the labelling of harnesses resolved. Forthwith connectors mounted on units are labelled "Unit Acronym Jxx" while floating connectors on harnesses that mate with the fixed units are labelled as "Unit Acronym Pxx". "xx" refers to a number unique to the particular connector on the unit.
		S10	Inserted correct drawing of 128-Way Pin allocation for P11 tail
		S10	Settled on a consistent name between for the Cooler Tail. Changed all instances of Heater Tail to Cooler Tail.
		I10, I11, I12, I13	Moved skin connector from these harnesses to S10, S11, S12, S13
		C2	Removed extra description of JFS P2/P4
		C1	Corrected table that had the table rows incorrectly aligned for some of the pins in the 128-Way column
		C11	Added missing pin allocations on P25, P27, P29
		F19/F20	Changed from 21 Way to 37 Way MDM
		F16 thru F27	Added mechanical drawing + backshell part numbers
		F23	Harness lay-up as J25 not J23
		F24, F25, F26 and F27	SMEC has flying leads now.
		F25	As per C11 FPU P29 <u>not</u> FPU P27
		C10, S10, FCU J23 FPU J23	Changed name of SPIRE Optical Bench Temperature Channel to FPU Filter Temperature. Thermistor moved within FPU.
		S10	Incorrect diagram of 128-Way inserted. Updated with correct one
		S10 - FCU J23	Photometer and Spectrometer Detector Box Temperatures swapped in tail listing so as to conform to the drawing.
		P11	Cooler tail listing: corrected 128-way Evaporator Heat Switch Heater A+ to be pin # 55 and Evaporator Heat Switch Heater B+ to be pin #56
		P19, P21 and P23	Corrected drawings of 128-way connector; corrected numerous errors in tail listings.
		P11	HS Spect Stim 2% Heater: Corrected pin allocations on 128-Way
		Annex 7	Revised and updated.
		4.8.	Added section specifying the two extra harnesses required for the STM programme
		C2, Tables	Renumbered signals. Changed Signals 7 and 8 to Spare triplets A and B.
		C2, JFS P1	Added information to note in the Harness Layup drawing. Indicated that several triplets terminate on open pins on the 128-Way #2
		JFS P7	Removed spurious ground wire in Harness Layup drawing
		C1/C2/C4	Indications of 12-ax groupings added to Harness Tables
		C1	In table, removed NC from Bolometer Triplet Anti cross-talk wires and indicated that they connect to signal ground on pin 13.
		C1	Deleted bolometer ground wires in table.
		S3	Harness layup drawing: Corrected to PSW Heater 1, PSW Heater 2, PSW Heater 3.... Not PSW Heater 1, PSW Heater 3, PSW Heater 4



SPIRE HARNESS DEFINITION DOCUMENT

Doc: SPIRE-RAL-PRJ-000608
Issue: 1.2
Date: 17/02/05
Page 7 of 245

ISSUE	DATE	SECTION	CHANGE(S) MADE
		JFP P27/P28	Added extra ground pin on 128-Way to conform with S3 Tails
		C3	PMW Heater A1 and PLW Heater were in incorrect positions. They have been swapped.
		C3	Ground pin incorrectly went to pin 65. Changed to connect to Pin 64
		C3	Tail listings: PMW Heater 1B and 2B connect to pin 65 not 91.
		S4	Clarified details of signal ground commoning on the 128-Way connector
		S4 128-Way	Pin numbers for Sig. 5 corrected to be pins 52 and 53; Sig. 16- now on pin 56; Missing pins for Sig 34 inserted (Pins 108 and 109); Sig. 45+ now on 26.
		S11/P19	Corrected 128-Way pin allocation table for the BSM Launch Latch
		S11/P19	Corrected 128-Way pin allocation table for the Chop and Jiggle position sensors
		C11/FPU P25	Corrected Polarity error on Phot. Point Stim. Listing
		Scope	Updated
		T7/T8	Deleted pin allocation
		S/I	Removed requirements for overall bundle insulation on S/I harnesses
		S1/C1	Updated DCU P27 to include an FPU Faraday Shield Link wire instead of Ground wire.
		S10/C10	Removed erroneous indication of STQ (should be UTQ) on the 128-Way pin allocation drawings for the heater functions
		Harness Listing	Changed Bolometer impedance requirement to 500 Ω
			Added columns indicating use of subsystem in various instrument modes
			Updated values of LVDT Sec Resistance
		S1-S10	Flipped view of 128-Way connectors to show view of exposed contacts
		4.6.1	Updated and corrected drawing of JFET Back harnesses
		4.6.2	Updated and corrected harness table for Photometer JFET BP Harness
		4.6.3	Updated and corrected harness table for Spectrometer JFET BP Harness
		S10/12,C10/12, Harness Listing	Shutter deleted. Skin connectors at SVM-CB renamed.
		S1, C1	PTC JFET Heater ground removed from spectrometer JFET heater ground and joined to the PTC ground within the 128-way
1.0	5/7/02		Issued
		C2,S2	Corrected some details on 128-way and reordered the tails
		C4	Corrected Spare Channel 3+ (Now 106 instead of 36)
		C3	Corrected errors on drawing of P27 and PLW Heater B Shield pin number in table
		C10	BSM Tail – corrected error in MDM Drawing (error showed incorrect LL Conf. Pin assignment)
		All	Add in screw post specifications
		S10-29	
		C13 Table	PLW HEATER B shld goes to pin 91 (B4)
		S1	Pin 105 is not commoned with pin 115.
		S2/S4	Pin 9 of JE/PE (PTC Signals) reallocated to FPU Faraday Shield Link
		Annex 3	The pixel tables have been deleted. The pixel allocations have been incorporated into the main body of the document
		Annex 6	The Grounding Diagram from RD 2 has been inserted (for reference) into the document
		C11/S11	Rearranged pins on 128-Way to make a better Faraday shield coverage (SMEC Drive FCU P17, FPU P29 *)
		C3 – JFS P7	Corrected polarity error on PTC Channel 3 and the PTC 5M Ω Resistor channels. *
		S4	Indicated that the shields of the JFET Heaters are commoned within the DRCU connector and terminated onto a lug on the connector backshell chassis
		Harness listings	Removed the Faraday Shield Link Wires in the I and S Harnesses
		C11/S11	Changed the position of the SMEC Drive Coil on the 128 Way so that a FPU



SPIRE HARNESS DEFINITION DOCUMENT

Doc: SPIRE-RAL-PRJ-000608
Issue: 1.2
Date: 17/02/05
Page 8 of 245

ISSUE	DATE	SECTION	CHANGE(S) MADE
			Faraday Shield pin could be added on the perimeter of the connector
		FPU P27	Corrected table indicating incorrect pin functions
		FPU P25	Corrected pins on BSM LL Conf.
		C4/S4	Spare channel 3+ not connected to 36 but rather 106
		FPU P29	SMEC LL#2, Corrected from pins 4,5 and 3 to 4,5 and 23.
		FPU P19	Changed Position sensor positions on 128 way so that there would be an extra FPU Faraday shield link pin on the edge of the connector
		S2/C2	Re-ordered labels of JFS P1, P2, P3 and P4 on C2 since spare channels now indicated on JPL 10209725 in now on SSW J06 instead of J05!. (This does not change the physical wiring apart from the connector labels)
		S2/C2	Fixed error where pin 4 of the 128-Way was indicated as FPU Faraday Shield Link. Now 4 is FPU Faraday Shield Link and 5 is Ground.
		C3/S3	Connected JFET
		C1/S2	Changed shields of JFET heater shields to be part of the FPU Faraday Shield Links
		JA/JB	Changed to Mil-C-38999 Series-I connectors from Series-II. These connectors have to be blind mated. Series-II is not scoop-proof, Series-I is.
1.1 Draft	27-Feb-03		Comments to be received before Wed 5 March.
			Changed all references to Dark Pixel from DP to DK
			C11/S11 Changed wording for the SMEC and the BSM Launch Latch Confirmation Shields that they are connected to FPU Ground. (FPU P25, FPU P27 and JA)
			Removed TBCs from SMEC Launch Latch #2 in FPU P27
			Included 128-Way Pin shield numbers for SMEC/SOB I/F Thermometer and SMEC Thermometer in the FPU P27 Listing
			Removed the phrase "Total used through 128 Wau = 36 + 31 + 29 = 96" form the C11 listing
			Added Specification of the FPU Faraday Shield Link Pins to C11
			Front cover – updated statement to say that the document is compliant with the SPIRE Block Diagram Issue 5.3
			Removed copy of SPIRE Block Diagram from end of document
1.1	5-March-03		Issued
			§4.8 STM Thermometry harnesses. Inline connectors removed. Pin out specified
			Average current changed to zero on redundant photometer and spectrometer bias tails in cryoharness summary.
			Average current in SMEC LVDT secondaries reduced to 5uA.
		4.8.4	Added EGSE harness to allow temperature measurement at CSL
			Included extra details of the FPU Input baffle thermometry harness and the PTC harness
			Renamed connector PTC P01 to F28A J01
			BDA-JFET Harnesses: Corrected Nanonics connector P/N
			<i>The Document "Making SPIRE ESD Safe" was added to the Applicable Documents List¹. On the cover page of Issue 1.1 of the SPIRE HDD, it was stated that the information in AD-2 would be included in issue 1.2 of the SPIRE HDD. The information was required before the issue of HDD 1.2, so the note was written and added as an AD in this document.</i>
			<i>Added details to F15 and F28 regarding PTC harnessing</i>
			<i>Added details regarding inline connectors for the PTC Harness, the addition of the</i>

¹ *On the cover page of Issue 1.1 of the SPIRE HDD, it was stated that the information in AD-2 would be included in issue 1.2 of the SPIRE HDD. The ESD safeing information was required before the issue of HDD 1.2, so the note was written and issued. The document has now been added as an AD to this document.*

ISSUE	DATE	SECTION	CHANGE(S) MADE
			<i>F28C Harness and the F29 and F30 Harnesses for the Inout Baffle Thermometry</i>
		4.2.4	<i>c.f. RD-5 Mod #1. Corrected channel labelling (Column 2) No change to physical wiring implied by this change. Compliant against HP-2-ASED-IC-0001 Iss. 2.6.in terms of Pixel allocation but not against channel number.</i>
		Table 4.2-4	<i>c.f. RD-5 Mod #2. Corrected pin allocations on 128-way for Channel 15 and 16 Compliant against HP-2-ASED-IC-0001 Iss. 2.6.</i>
		Table 4.2-6	<i>c.f. RD-5 Mod#3. Corrected sequence of Pixel references (Column 3). Compliant against HP-2-ASED-IC-0001 Iss. 2.6</i>
		Table 4.2-14	<i>c.f. RD-5 Mod#4. Corrected polarity error in the 128-Way connector in the SMEC Harness. Compliant against HP-2-ASED-IC-0001 Iss. 2.6</i>
		Table 4.4-1	<i>c.f. RD-5 Mod#5. SLW Pixel-C3 ground s.b. Channel 14 ground. (Column 2). Compliant against HP-2-ASED-IC-0001 Iss. 2.6</i>
		Table 4.4-1	<i>c.f. RD-5 Mod#6. SLW_JFETV_B2 shield and SLW_JFETV_A2 shield should be connected to pins 26 and not 6. SLW_JFETV_A2 compliant against HP-2-ASED-IC-0001 Iss. 2.6 SLW_JFETV_A2 not compliant against HP-2-ASED-IC-0001 Iss. 2.6 however it is electrically equivalent.</i>
		4.4.3	<i>c.f. RD-5 Mod#7,8 and 9.References to D2 and D4 changed to B2 and B4. Implementation of ground different in HP-2-ASED-IC-0001 Iss. 2.6 but nonetheless, compliant to SPIRE design intent.</i>
		Table 4.4-6	<i>c.f. RD-5 Mod#10. PLW Pixel-B4 ground s.b. Channel 14 ground. (Column 2). Compliant against HP-2-ASED-IC-0001 Iss. 2.6</i>
		Table 4.4-8	<i>c.f. RD-5 Mod#11. Column headers should be P05, P06, P07 and P08 not J05, J06, J07 and J08. Compliant against HP-2-ASED-IC-0001 Iss. 2.6</i>
		Table 4.4-8	<i>c.f. RD-5 Mod#12. PSW Pixel-A3 ground s.b. Channel 14 ground. (Column 2). Compliant against HP-2-ASED-IC-0001 Iss. 2.6</i>
		Table 4.4-9	<i>c.f. RD-5 Mod#13. PSW Pixel-C13 ground s.b. Channel 14 ground. (Column 2). Compliant against HP-2-ASED-IC-0001 Iss. 2.6</i>
		Table 4.2-16	<i>c.f. RD-5 Mod#14. Table should be labelled with P29 not P27. Compliant against HP-2-ASED-IC-0001 Iss. 2.6</i>
		Table 4.2-15 Table 4.2-10 Table 4.4-11 Table 4.4-13	<i>Clarified wiring of S-Cal and P-Cal as per email from C.Cara to John Delderfield of Tue, 02/03/04. "A" wires are current drive, "B" wires are voltage sense. This does not change physical wiring.</i>
		Annex 1	<i>Re-inserted columns relating duty cycles, peak and average dissipation</i>
		Annex 1	<i>RE: C11, SMEC Drive. Split current equally between Nominal and Robust wires.</i>
		Annex 1	<i>RE: C11, BSM LL Drive corrected table to indicate STP instead of STT</i>
		§3	<i>Updated Block Diagram to include the schematic layout of th e PTC and Thermometry harnesses</i>
		§ 4.6.2.1 and §4.6.2.2	<i>Updated details of the JFET Backharnesses. Drawings of interconnections at backshells.</i>
1.2 pr	15/11/2004		<i>Circuited pre-release version of HDD 1.2 for IQR. Any comments to be incorporated for formal release at the end of IQR.</i>

ACRONYM LIST

Term	Meaning
ADC	Analogue to Digital Converter
AIV	Assembly, Integration and Verification
AME	Absolute Measurement Error
AOCS	Attitude and Orbit Control System
APART	Arizona's Program for the Analysis of Radiation Transfer
APE	Absolute Pointing Error
ASAP	Advanced Systems Analysis Program
AVM	Avionics Model
BDA	Bolometer Detector Assembly
BFL	Back Focal Length
BRO	Breault Research Organization
BSM	Beam Steering Mirror
CDMS	Command and Data Management System
CDMU	Command and Data Management Unit
CDR	Critical Design Review
CMOS	Complimentary Metal Oxide Silicon
CPU	Central Processing Unit
CVV	Cryostat Vacuum Vessel
DAC	Digital to Analogue Converter
DAQ	Data Acquisition
DCU	Detector Control Unit = HSDCU
DPU	Digital Processing Unit = HSDPU
DQE	Detective Quantum Efficiency
DSP	Digital Signal Processor
EDAC	Error Detection and Correction
EGSE	Electrical Ground Support Equipment
EMC	Electro-magnetic Compatibility
EMI	Electro-magnetic Interference
FCU	FCU Control Unit = HSFCU
FIR	Far Infrared
FIRST	Far Infra-Red and Submillimetre Telescope
FOV	Field of View
FPGA	Field Programmable Gate Array
FPU	Focal Plane Unit
FTS	Fourier Transform Spectrometer
FWHM	Full Width Half maximum
HK	House Keeping
HOB	Herschel Optical Bench
HPDU	Herschel Power Distribution Unit
HSDCU	Herschel-SPIRE Detector Control Unit
HSDPU	Herschel-SPIRE Digital Processing Unit
HSFCU	Herschel-SPIRE FPU Control Unit
HSO	Herschel Space Observatory
IF	Interface
IID-A	Instrument Interface Document - Part A
IID-B	Instrument Interface Document - Part B
IMF	Initial Mass Function
IR	Infrared
IRD	Instrument Requirements Document



SPIRE HARNESS DEFINITION DOCUMENT

Doc: SPIRE-RAL-PRJ-000608
Issue: 1.2
Date: 17/02/05
Page 11 of 245

Term	Meaning
IRTS	Infrared Telescope in Space
ISM	Interstellar Medium
ISO	Infrared Space Observatory
JFET	Junction Field Effect Transistor
LCL	Latching Current Limiter
LIA	Lock-In Amplifier
LVDT	Linear Variable Differential Transformer
LWS	Long Wave Spectrometer (an instrument used on ISO)
MAC	Multi Axis Controller
MCU	Mechanism Control Unit = HSMCU
NEP	Noise Equivalent Power
NTD	Neutron Transmutation Doped
OBS	On-Board Software
OPD	Optical Path Difference
PACS	Photodetector Array Camera and Spectrometer
PCAL	Photometer Calibration source
PID	Proportional, Integral and Differential (used in the context of feedback control loop architecture)
PLW	Photometer, Long Wavelength
PMW	Photometer, Medium Wavelength
POF	Photometer Observatory Function
PROM	Programmable Read Only Memory
PSW	Photometer, Short Wavelength
PTC	Photometer Thermal Control
PUS	Packet Utilisation Standard
RMS	Root Mean Squared
SCAL	Spectrometer Calibration Source
SIH-CS	SPIRE Instrument Harness – Cryogenic Section
SIH-IS	SPIRE Instrument Harness – Intermediate Section
SIH-SS	SPIRE Instrument Harness – SVM Section
SMPS	Switch Mode Power Supply
SOB	SPIRE Optical Bench
SOF	Spectrometer Observatory Function
SPIRE	Spectral and Photometric Imaging Receiver
SSSD	SubSystem Specification Document
STP	Screened Twisted Pair
STQ	Screened Twisted Quad
STT	Screened Twisted Triple
SVM	Service Module
SVM-CB	Service Module Connector Bracket. Mounted on top of the SVM. Used to connect I and S Harnesses
TBC	To Be Confirmed
TBD	To Be Determined
TC	Thermal Control
TP	Twisted Pair (unscreened)
TQ	Twisted Quad (unscreened)
TT	Twisted Triple (unscreened)
URD	User Requirements Document
UV	Ultra Violet
WE	Warm Electronics
ZPD	Zero Path Difference



SPIRE HARNESS DEFINITION DOCUMENT

Doc: SPIRE-RAL-PRJ-000608
Issue: 1.2
Date: 17/02/05
Page 12 of 245

DISTRIBUTION LIST

Institute	Holder	Issue/ Revision and Distribution Date							
		0.5 22/8/01	0.6 15/9/01	0.7 19/9/01	0.8 2/11/01	0.9 10/3/02	1.0 05/07/02	1.1 05/03/03	1.2
RAL	Delderfield	x	X	x	x	x	x	x	
	Swinyard	x	X	x	x	x	x	x	
	Griffin	x	X	x	x	x	x	x	
	Parker	x	X	x	x	x	x	x	
	King	x	X	x	x	x	x	x	
	Smith							x	
QMW/ Cardiff	Griffin	x	X	x	x	x	x	x	
	Hargrave	x	X	x	x	x	x	x	
ATC	Cunningham	x	X	x	x	x	x	x	
	Stobie	x	X	x	x	x	x	x	
MSSL	Winter	x	X	x	x	x	x	x	
	Brockley-Blatt					x	x	x	
CEA-SBT	Duband	x	X	x	x	x	x	x	
CEA-SAP	Cara	x	X	x	x	x	x	x	
	Auguères	x	X	x	x	x	x	x	
	Pinsard	x	X	x	x	x	x	x	
JPL	Bock	x	x	x	x	x	x	x	
	Hristov	x	x	x	x	x	x	x	
LAM	Pouliquen	x	x	x	x	x	x	x	
	Ferrand			x	x	x	x	x	
ESA	Jackson	x	x	x	x	x	x	x	
	Heske	x	x	x	x	x	x	x	
	Bruston	x	x	x	x	x	x		
CESR	Pons	x	x	x	x	x	x	x	
IFSI	Giorgio	x	x	x	x	x	x	x	
	Orfei	x	x	x	x	x	x	x	
Alenia	Cesa						x	x	
ALCATEL	Collaudin	x	x	x	x	x	x	x	
Astrium	Fass		x	x	x	x	x	x	
	Lang			x	x	x	x	x	

CONTENTS

CHANGE RECORD	2
ACRONYM LIST	10
DISTRIBUTION LIST.....	12
LIST OF TABLES.....	15
1. SCOPE.....	16
2. APPLICABLE DOCUMENTS	16
2.1 REFERENCE DOCUMENTS	16
3. INTRODUCTION.....	17
4. HARNESS DETAILS.....	20
4.1 WARM HARNESSES	20
4.1.1 <i>W1- HSDPU-P to HSDCU-P</i>	<i>20</i>
4.1.2 <i>W2 - HSDPU-R to HSDCU-R.....</i>	<i>22</i>
4.1.3 <i>W3 - HSDPU-P to HSFCU (SCU)-P</i>	<i>23</i>
4.1.4 <i>W4 - HSDPU-R to HSFCU (SCU)-R</i>	<i>24</i>
4.1.5 <i>W5 - HSDPU-P to HSFCU (MCU)-P</i>	<i>25</i>
4.1.6 <i>W6 - HSDPU-R to HSFCU (MCU)-R.....</i>	<i>26</i>
4.1.7 <i>W7 - HSFCU-P to HSDCU-P</i>	<i>27</i>
4.1.8 <i>W8 - HSFCU-R to HSDCU-R</i>	<i>28</i>
4.2 SVM CRYOHARNESSES	29
4.2.1 <i>S1 SVM-CB 1 – DRCU (Type3) Spectrometer Biases and SLW</i>	<i>30</i>
4.2.2 <i>S2 SVM-CB 2 – DRCU (Type 4) SSW and PTC.....</i>	<i>39</i>
4.2.3 <i>S3 SVM-CB 3 – DRCU (Type 2) Photometer Biases</i>	<i>48</i>
4.2.4 <i>S4 SVM-CB 4 – DRCU (Type 1) PMW</i>	<i>56</i>
4.2.5 <i>S5 SVM-CB 5 – DRCU (Type 1) PMW</i>	<i>63</i>
4.2.6 <i>S6 SVM-CB 6 – DRCU (Type 1) PLW</i>	<i>68</i>
4.2.7 <i>S7 SVM-CB 7 – DRCU (Type 1) PSW.....</i>	<i>71</i>
4.2.8 <i>S8 SVM-CB 8 – DRCU (Type 1) PSW.....</i>	<i>74</i>
4.2.9 <i>S9 SVM-CB 9 – DRCU (Type 1) PSW.....</i>	<i>77</i>
4.2.10 <i>S10 SVM-CB 10 – DRCU AUX-P</i>	<i>80</i>
4.2.11 <i>S11 SVM-CB 11 – DRCU DRV-P</i>	<i>87</i>
4.2.12 <i>S12 SVM-CB 12 – DCU AUX-R.....</i>	<i>100</i>
4.2.13 <i>S13 SVM-CB 13 – DCU DRV-R.....</i>	<i>101</i>
4.3 INTERMEDIATE HARNESSES	102
4.3.1 <i>I1 SVM-CB 1 – CVV1.....</i>	<i>103</i>
4.3.2 <i>I2 SVM-CB 2 – CVV2.....</i>	<i>104</i>
4.3.3 <i>I3 SVM-CB 3 – CVV 3.....</i>	<i>105</i>
4.3.4 <i>I4 SVM-CB 4 – CVV 4.....</i>	<i>106</i>
4.3.5 <i>I5 SVM-CB 5 – CVV 5.....</i>	<i>107</i>
4.3.6 <i>I6 SVM-CB 6 – CVV 6.....</i>	<i>108</i>
4.3.7 <i>I7 SVM-CB 7 – CVV 7.....</i>	<i>109</i>
4.3.8 <i>I8 SVM-CB 8 – CVV 8.....</i>	<i>110</i>
4.3.9 <i>I9 SVM-CB 9 – CVV 9.....</i>	<i>111</i>
4.3.10 <i>I10 SVM-CB 10 – CVV 10.....</i>	<i>112</i>
4.3.11 <i>I11 SVM-CB 11 – CVV 11.....</i>	<i>113</i>
4.3.12 <i>I12 SVM-CB 12 – CVV 12.....</i>	<i>114</i>
4.3.13 <i>I13 SVM-CB 13 – CVV 13.....</i>	<i>115</i>
4.4 CRYOGENIC HARNESSES	116
4.4.1 <i>C1 CVV1 to HSJFS Type3.....</i>	<i>117</i>
4.4.2 <i>C2 CVV2 to HSJFS Type4.....</i>	<i>123</i>
4.4.3 <i>C3 CVV3 to HSJFP Type2</i>	<i>130</i>
4.4.4 <i>C4 CVV4 to HSJFP Type1</i>	<i>137</i>
4.4.5 <i>C5 CVV5 to HSJFP Type1</i>	<i>143</i>
4.4.6 <i>C6 CVV6 to HSJFP Type1</i>	<i>148</i>
4.4.7 <i>C7 CVV7 to HSJFP Type1</i>	<i>151</i>

4.4.8	C8 CVV8 to HSJFP Type1	154
4.4.9	C9 CVV9 to HSJFP Type1	157
4.4.10	C10 CVV10 to HSFPU AUX-P	160
4.4.11	C11 CVV11 to HSFPU DRV-P	168
4.4.12	C12 CVV12 to HSFPU AUX-R	176
4.4.13	C13 CVV13 to HSFPU DRV-R	177
4.5	FPU HARNESSES	179
4.5.1	F1 PSW BDA J01 to HSJFP J29	179
4.5.2	F2 PSW BDA J02 to HSJFP J30	181
4.5.3	F3 PSW BDA J03 to HSJFP J31	182
4.5.4	F4 PSW BDA J04 to HSJFP J32	182
4.5.5	F5 PSW BDA J05 to HSJFP J33	182
4.5.6	F6 PSW BDA J06 to HSJFP J34	182
4.5.7	F7 PLW BDA J01 to HSJFP J35	183
4.5.8	F8 PLW BDA J02 to HSJFP J36	183
4.5.9	F9 PMW BDA J01 to HSJFP J37	184
4.5.10	F10 PMW BDA J02 to HSJFP to J38	184
4.5.11	F11 PMW BDA J03 to HSJFP to J39	184
4.5.12	F12 PMW BDA J04 to HSJFP to J40	184
4.5.13	F13 SSW BDA J05 to HSJFS J11	185
4.5.14	F14 SSW BDA J06 to HSJFS J12	185
4.5.15	F15 SLW BDA J01 to HSJFS J13 (plus PTC Cold harnessing – F28)	186
4.5.16	F16 COOLER-P to FPU J19A	187
4.5.17	F17 COOLER-R to FPU J20A	188
4.5.18	F18 SCal-P to FPU J21A	189
4.5.19	F19 SCal-R to FPU J22A	190
4.5.20	F20 THERM-P to FPU J23A	191
4.5.21	F21 THERM-R from FPU J24A	193
4.5.22	F22 BSM-P to FPU J25A	195
4.5.23	F23 BSM-R to FPU J26A	196
4.5.24	F24 SMEC Launch (Prime) connected to FPU J27A	197
4.5.25	F25 SMEC Control (Prime) connected to FPU J29A	198
4.5.26	F26 SMEC Launch (Red.) connected to FPU J28A	199
4.5.27	F27 SMEC Control (Red.) connected to FPU J30A	200
4.5.28	F28A and F28B Assembly – PTC (F28A J01 to HSJFS J14)	201
4.5.29	F28C PTC (F28C P01 to F29C P02)	204
4.5.30	F28D PTC J01	206
4.5.31	F29 Input Baffle Thermometry (Feedthru to SOB/Cover)	207
4.5.32	F30 Input Baffle Thermometry (SOB/Cover to Sensor)	208
4.6	JFET UNIT BACK-HARNESSES	209
4.6.1	Overview	209
4.6.2	BP-Photometer	211
	4.6.2.1	HSJFP – BP1 (PSW) 212
	4.6.2.2	HSJFP – BP2 (PMW/PLW) 215
4.6.3	BS-Spectrometer	218
4.7	TEST HARNESSES	222
4.7.1	T1 1553 Bus A	222
4.7.2	T2 1553 Bus B	223
4.7.3	T3 DPU-P Power	224
4.7.4	T4 DPU-R Power	225
4.7.5	T5 FCU-P Power	226
4.7.6	T6 FCU-R Power	227
4.7.7	T7 Mechanisms Launch Lock Confirm (Prime)	227
4.7.8	T8 Mechanisms Launch Lock Confirm (Redundant)	227

4.8	STM THERMOMETRY HARNESSES	228
4.8.1	External STM	228
4.8.2	Internal STM	231
4.8.3	CQM/STM Level-0 Strap Harness	233
4.8.4	CQM Cryovibration Thermometry Harness	234
ANNEX 1 – INTERNAL CRYOSTAT WIRING LIST		236
ANNEX 2 – EXTERNAL CRYOSTAT WIRING LIST		240
ANNEX 3 - BDA CHANNELS		243
ANNEX 4 - WHAT IS 12-AX?		243
ANNEX 5 – CVV BULKHEAD EMI BACKSHELLS.....		243
ANNEX 6 - SPIRE GROUNDING DIAGRAM.....		244
ANNEX 7 – PTC CRYOHARNESSING.....		245

List of Tables

Table 4.2-1-	SIH-SS-01 Listing.....	35
Table 4.2-2 -	SIH-SS-02 Listing.....	45
Table 4.2-3 -	SIH-SS-03 Listing.....	53
Table 4.2-4 -	SIH-SS-04 Listing.....	60
Table 4.2-5 -	SIH-SS-05 Listing.....	65
Table 4.2-6 -	SIH-SS-06 Listing.....	68
Table 4.2-7 -	SIH-SS-07 Listing.....	71
Table 4.2-8 -	SIH-SS-08 Listing.....	74
Table 4.2-9 -	SIH-SS-09 Listing.....	77
Table 4.2-10-	SIH-SS-10 Cooler Tail Listing P11	84
Table 4.2-11 -	SIH-SS-10 FPU Thermometry Tail A (FCU P23) Listing.....	85
Table 4.2-12 -	SIH-SS-10 FPU Thermometry Tail B (FCU P25) Listing.....	86
Table 4.2-13 -	SIH-SS-11 Temperature Tail (P21) Listing.....	95
Table 4.2-14 -	SIH-SS-11 SMEC Control Tail (FCU P17) Listing.....	96
Table 4.2-15 -	SIH-SS-11 Photometer Stimulus Heater P13 Listing	97
Table 4.2-16	SIH-SS-11 SMEC Launch Tail (FCU P29) Listing	97
Table 4.2-17 -	SIH-SS-11 BSM Tail (FCU P19) Listing	98
Table 4.2-18	SIH-SS-11 Mechanism Launch Latch Confirm: SVM-CB JA Listing	99
Table 4.4-1 -	SIH-CS-01 Listing	120
Table 4.4-2 -	SIH-CS-02 Listing	127
Table 4.4-3 -	SIH-CS-03 Listing	134
Table 4.4-4 -	SIH-CS-04 Listing	140
Table 4.4-5 -	SIH-CS-05 Listing	145
Table 4.4-6 -	SIH-CS-06 Listing	148
Table 4.4-7 -	SIH-CS-07 Listing	151
Table 4.4-8 -	SIH-CS-08 Listing	154
Table 4.4-9 -	SIH-CS-09 Listing	157
Table 4.4-10 -	SIH-CS-10 Cooler Tail (FPU P19) Listing.....	165
Table 4.4-11 -	SIH-CS-10 Spectrometer Stimulus Tail (FPU P21) Listing	166
Table 4.4-12 -	SIH-CS-10 FPU Thermometry Tail (P23) Listing.....	166
Table 4.4-13 -	SIH-CS-11 BSM Tail (FPU P25) Listing	173
Table 4.4-14 -	SIH-CS-11 SMEC Launch/Therm.Tail (FPU P27) Listing	174
Table 4.4-15 -	SIH-CS-11 SMEC Control Tail (FPU J29) Listing	175
Table 4.5-1-	PTC Wiring Summary	203

1. SCOPE

This document at its latest issue is the primary definition of all HERSCHEL SPIRE flight harnesses.

It is an applicable document in the SPIRE IID-B, and as such is called up, and is applicable in full to all SPIRE subsystems

It also contains information covering some test harnesses, but some harnesses / back-planes that stay entirely within sub-systems are not necessarily included.

Electrical and physical data are included, included contact functions, screening details. This information will become more detailed as designs are refined until it can be used as a basis for harness manufacture. The detailed harness shapes for the F-Harnesses are currently not included within this document.

A function count/format/sizing summary list for the C/I/S series cryoharness is appended as an Annex and may, together with other summary information, be edited into the SPIRE IID-B. SPIRE is unusual in that these harnesses are not standard I/Fs between separately grounded systems but rather links within extended analogue systems. As such, the conductor count/sizing summary list alone is not an adequate specification to ensure the required performance, particularly with respect to consistency between ground calibration and flight performance.

The SPIRE instrument-grounding diagram is appended.

2. APPLICABLE DOCUMENTS

ID	TITLE	NUMBER
AD-1	SPIRE Development Plan and Model Philosophy	SPIRE-RAL-PRJ-000035
AD-2	Making SPIRE ESD Safe	SPIRE-RAL-NOT-002028

2.1 REFERENCE DOCUMENTS

ID	TITLE	NUMBER	ISSUE	DATE
RD-1	SPIRE Block Diagram	SPIRE-RAL-DWG-000646	5.0	19 th November 2002
RD-2	SPIRE grounding and screening philosophy	SPIRE-RAL-PRJ-00624	1.0	1 st October 2002
RD-3	SPIRE & PACS Sorption Coolers ICD	HSS-SBT-ICD-012	1.3	7 th December 2001
RD-4	SPIRE FPU Subsystem Harness Routing., (Including the following sheets) A1/5264/315 Cable Harness General Assembly A1/5264/315-1 BSM Harness Primary A1/5264/315-2 BSM Harness Redundant A1/5264/315-3 Cooler Harness Primary A1/5264/315-4 Cooler Harness Redundant A1/5264/315-5 SCAL Harness Primary A1/5264/315-6 SCAL Harness Redundant A1/5264/315-7 Thermometry Harness Primary A1/5264/315-8 Thermometry Harness (STM) A1/5264/315-10 Thermometry Harness Redundant	MSSL - A1/5264/315	1.0	1 st August 2002
RD-5	SPIRE HDD 1.1 Deltas	SPIRE-RAL-NOT-001819	4.0	08/07/04



SPIRE HARNESS DEFINITION DOCUMENT

Doc: SPIRE-RAL-PRJ-000608
 Issue: 1.2
 Date: 17/02/05
 Page 17 of 245

3. INTRODUCTION

The overall HERSCHEL SPIRE harnesses are configured as shown:

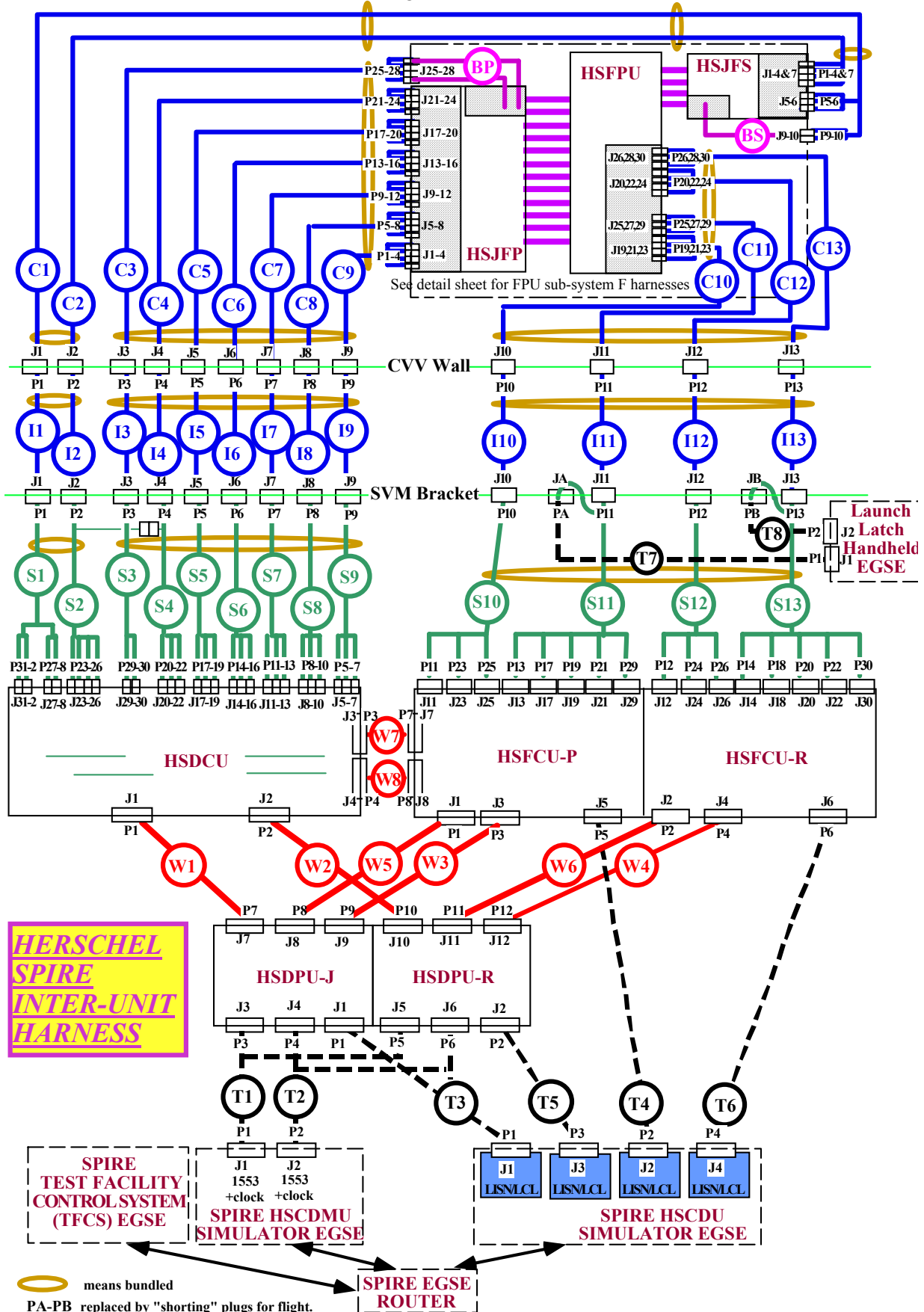

The details in the HSFPU are as follows:

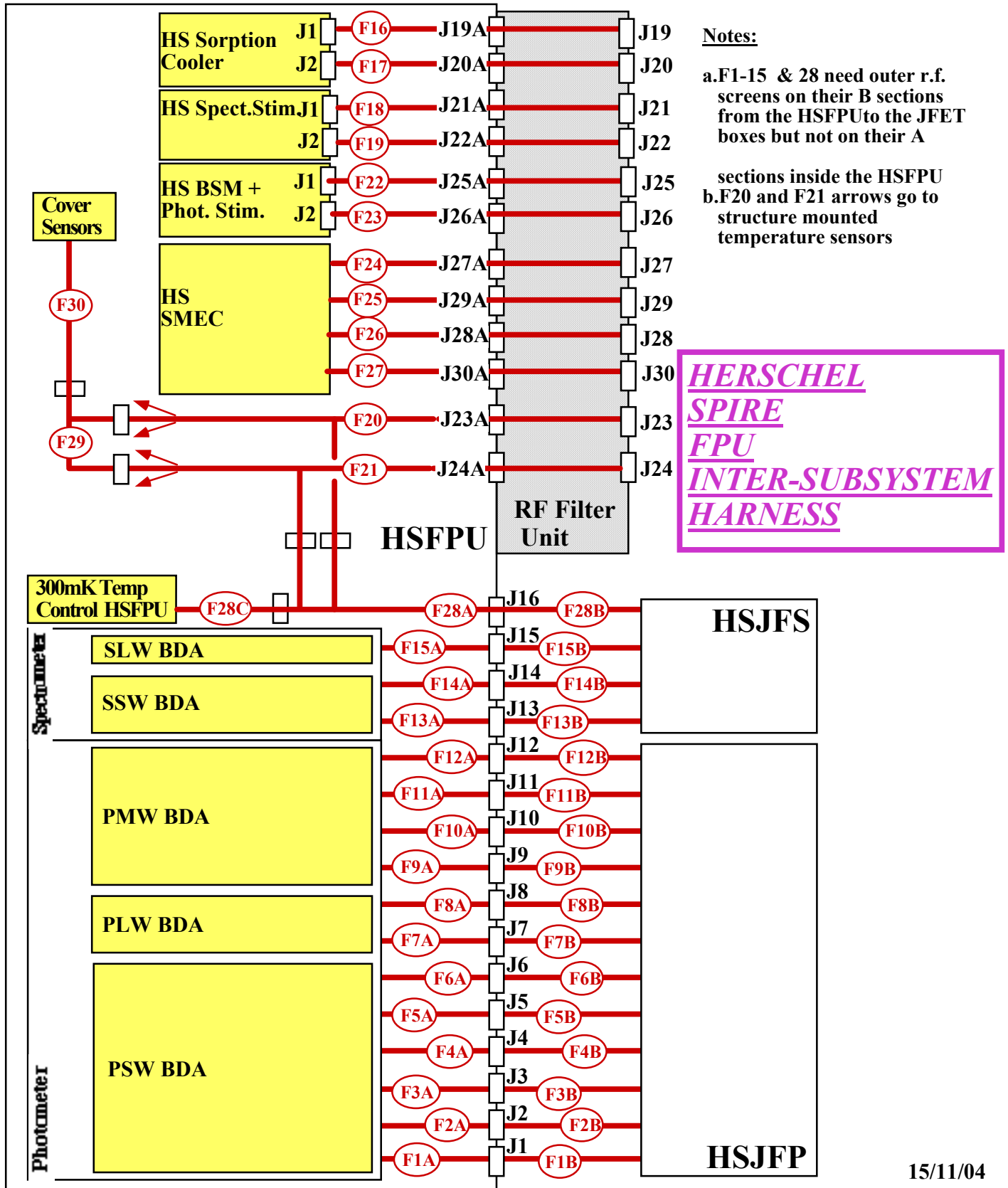

Notes:

1. There are some "loop" harnesses that start and terminate within the same unit, such as on the HS DCU. These are treated as parts of the units rather than instrument harness.
2. The HSJFS + HSJFP "back-harnesses", BS and BP respectively, although supplied as part of the JFET units are now within the scope of this document as this permits the instrument's architecture to be followed more clearly.
3. The Test harnesses, type T, are shown dashed as they are non-flight and will be substituted by ESA Contractor furnished items as SPIRE is integrated on to HERSCHEL. They will be RAL furnished for use with the instrument EGSE, but individual suppliers will need to make their own versions for unit level testing before delivery to the instrument.
4. The Cryogenic and SVM harnesses, types C and S, are RAL furnished for instrument level calibration but again are substituted by ESA Contractor furnished items as SPIRE is integrated on to HERSCHEL. Harnesses of type "I" are not needed for instrument level calibration.
5. The provision of the FPU harnesses (F series) is the responsibility of the institute that sources the subsystem to which they connect, noting that the structure subsystem group covers the temperature sensors.
6. The model philosophy definition, in AD-1, can be used to determine how many versions of each harness are required for the programme. For SPIRE it is necessary that most harnesses, of whatever version, are EMC and thermally representative.
7. For the D-Subminiature connectors on the SVM that interface with the S-Cryoharnesses or with Herschel, the following Glenair backshells are used:
 - a. For Top Entry: 557-T-357 M
 - b. For End Entry: 557-E-359 M
 - c. For 45° Entry: 557-B-357 M
 For the D-Subminiature connectors on the SVM that are internal SPIRE to SPIRE interfaces, the following Glenair backshells are used:
 - a. For Top Entry: 557-T-051 M
 - b. For End Entry: 557-E-113 M
 - c. For 45° Entry: 557-102 M or 557-103 M according to the direction the harness exits the backshell
8. For the MDM connectors inside the Herschel Cryostat supplied by the ESA Contractor, the following backshells are used:
 - a. For Top entry: 507-T-196 M
 - b. For End entry: 507-E-199 M
 - c. For 45° entry: 507-E-196 M
9. Some inner shields of signal groups within a single harness are connected together at the connectors (MDM, D-Sub and 128-Way) to form an analogue ground reference network for EMC and anti-crosstalk reasons. This is indicated in the drawings of the Harness Layups and on the tables of the pin assignments of the 128-Way connectors by the letters A, B, C and D. When there are ground planes formed on several tails of the same harness, these letters are suffixed by digits to differentiate between them. This convention of assigning a letter to commoned grounds is adhered to in the tail listing tables.

4. HARNESS DETAILS

4.1 Warm Harnesses

4.1.1 W1- HSDPU-P to HSDCU-P

Overall Mechanical Drawing

Geometry specified by Alenia Spazio

1:1 harness of insulated screened 28AWG twisted pairs with backshell to backshell screen, covered on outside with insulation.

Connector/Backshell Details

Prime Side Harness

DBMA 25 P + Glenair 557 - E - 113 - M - 3 - TBD - H - 0 - TBD to DCUJ1

DBMA 25 S + Glenair 557 - 102 - M - 3 - TBD - H - 0 - TBD to DPUJ7

Harness Layup

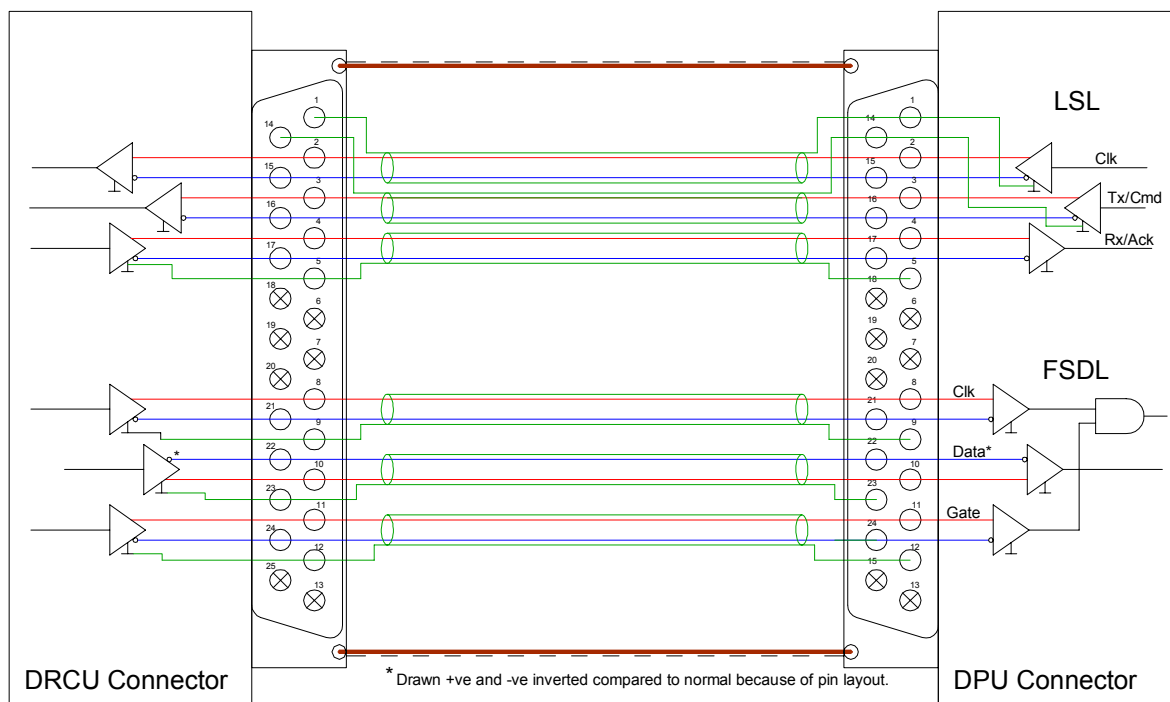

Contact Details: Wired 1:1 in harness					
Signal Name	Pin	Wire	Signal Name	Pin	Wire
C_CLK_SHD	1		C_CMD_SHD	14	
C_CLK_DCU_P+	2	28AWG STP-A	C_CLK_DCU_P-	15	28AWG STP-A
C_CMD_DCU_P+	3	28AWG STP-B	C_CMD_DCU_P-	16	28AWG STP-B
C_RES_DCU_P+	4	28AWG STP-C	C_RES_DCU_P-	17	28AWG STP-C
C_RES_SHD	5			18	
	6			19	
	7			20	
D_CLK_DCU_P+	8	28AWG STP-D	D_CLK_DCU_P-	21	28AWG STP-D
D_CLK_SHD	9		D_DAT_DCU_P-	22	28AWG STP-E
D_DAT_DCU_P+	10	28AWG STP-E	D_SHD	23	
D_GAT_DCU_P+	11	28AWG STP-F	D_GAT_DCU_P-	24	28AWG STP-E
D_GAT_SHD	12			25	
	13				
RF Overshield	EMC Backshell-Backshell				

CEA to provide PFM W1 according to Alenia Spazio routing specifications.

4.1.2 W2 - HSDPU-R to HSDCU-R

Overall Mechanical Drawing

Geometry specified by Alenia Spazio

1:1 harness of insulated screened 28AWG twisted pairs with backshell to backshell screen, covered on outside with insulation.

Connector/Backshell Details

Redundant Side Harness

DBMA 25 P + Glenair 557 - E - 113 - M - 3 - TBD - H - 0 - TBD to DCUJ2

DBMA 25 S + Glenair 557 - 103 - M - 3 - TBD - H - 0 - TBD to DPUJ10

Harness Layup

As W1

Contact Details

Wired 1:1 in harness

Signal Name	Pin	Wire	Signal Name	Pin	Wire
C_CLK_SHD	1		C_CMD_SHD	14	
C_CLK_DCU_R+	2	28AWG STP-A	C_CLK_DCU_R-	15	28AWG STP-A
C_CMD_DCU_R+	3	28AWG STP-B	C_CMD_DCU_R-	16	28AWG STP-B
C_RES_DCU_R+	4	28AWG STP-C	C_RES_DCU_R-	17	28AWG STP-C
C_RES_SHD	5			18	
	6			19	
	7			20	
D_CLK_DCU_R+	8	28AWG STP-D	D_CLK_DCU_R-	21	28AWG STP-D
D_CLK_SHD	9		D_DAT_DCU_R-	22	28AWG STP-E
D_DAT_DCU_R+	10	28AWG STP-E	D_SHD	23	
D_GAT_DCU_R+	11	28AWG STP-F	D_GAT_DCU_R-	24	28AWG STP-E
D_GAT_SHD	12			25	
	13				
RF Overshield	EMC Backshell-Backshell				

CEA to provide PFM W2 according to Alenia Spazio routing specifications.

4.1.3 W3 - HSDPU-P to HSFCU (SCU)-P

Overall Mechanical Drawing

Geometry specified by Alenia Spazio

1:1 harness of insulated screened 28AWG twisted pairs with backshell to backshell screen, covered on outside with insulation.

Connector/Backshell Details

Redundant Side Harness

DBMA 25 P + Glenair 557 - E - 113 - M - 3 - TBD - H - 0 - TBD to FCUJ3
 DBMA 25 S + Glenair 557 - E - 113 - M - 3 - TBD - H - 0 - TBD to DPUJ9

Harness Layup

As W1

Contact Details

Wired 1:1 in harness

Signal Name	Pin	Wire	Signal Name	Pin	Wire
C_CLK_SHD	1		C_CMD_SHD	14	
C_CLK_SCU_P+	2	28AWG STP-A	C_CLK_SCU_P-	15	28AWG STP-A
C_CMD_SCU_P+	3	28AWG STP-B	C_CMD_SCU_P-	16	28AWG STP-B
C_RES_SCU_P+	4	28AWG STP-C	C_RES_SCU_P-	17	28AWG STP-C
C_RES_SHD	5			18	
	6			19	
	7			20	
D_CLK_SCU_P+	8	28AWG STP-D	D_CLK_SCU_P-	21	28AWG STP-D
D_CLK_SHD	9		D_DAT_SCU_P-	22	28AWG STP-E
D_DAT_SCU_P+	10	28AWG STP-E	D_SHD	23	
D_GAT_SCU_P+	11	28AWG STP-F	D_GAT_SCU_P-	24	28AWG STP-E
D_GAT_SHD	12			25	
	13				
RF Overshield	EMC Backshell-Backshell				

CEA to provide PFM W3 according to Alenia Spazio routing specifications.

4.1.4 W4 - HSDPU-R to HSFCU (SCU)-R

Overall Mechanical Drawing

Geometry specified by Alenia Spazio

1:1 harness of insulated screened 28AWG twisted pairs with backshell to backshell screen, covered on outside with insulation.

Connector/Backshell Details

Redundant Side Harness

DBMA 25 P + Glenair 557 - E - 113 - M - 3 - TBD - H - 0 - TBD to FCUJ4
 DBMA 25 S + Glenair 557 - E - 113 - M - 3 - TBD - H - 0 TBD to DPUJ12

Harness Layup

As W1

Contact Details

Wired 1:1 in harness

Signal Name	Pin	Wire	Signal Name	Pin	Wire
C_CLK_SHD	1		C_CMD_SHD	14	
C_CLK_SCU_R+	2	28AWG STP-A	C_CLK_SCU_R-	15	28AWG STP-A
C_CMD_SCU_R+	3	28AWG STP-B	C_CMD_SCU_R-	16	28AWG STP-B
C_RES_SCU_R+	4	28AWG STP-C	C_RES_SCU_R-	17	28AWG STP-C
C_RES_SHD	5			18	
	6			19	
	7			20	
D_CLK_SCU_R+	8	28AWG STP-D	D_CLK_SCU_R-	21	28AWG STP-D
D_CLK_SHD	9		D_DAT_SCU_R-	22	28AWG STP-E
D_DAT_SCU_R+	10	28AWG STP-E	D_SHD	23	
D_GAT_SCU_R+	11	28AWG STP-F	D_GAT_SCU_R-	24	28AWG STP-E
D_GAT_SHD	12			25	
	13				
RF Overshield	EMC Backshell-Backshell				

CEA to provide PFM W4 according to Alenia Spazio routing specifications.

4.1.5 W5 - HSDPU-P to HSFCU (MCU)-P

Overall Mechanical Drawing

Geometry specified by Alenia Spazio

1:1 harness of insulated screened 28AWG twisted pairs with backshell to backshell screen, covered on outside with insulation.

Connector/Backshell Details
Redundant Side Harness

DBMA 25 P + Glenair 557 - E - 113 - M - 3 - TBD - H - 0 - TBD to FCUJ1
 DBMA 25 S + Glenair 557 - 102 - M - 3 - TBD - H - 0 - TBD to DPUJ8

Harness Layup

As W1

Contact Details
Wired 1:1 in harness

Signal Name	Pin	Wire	Signal Name	Pin	Wire
C_CLK_SHD	1		C_CMD_SHD	14	
C_CLK_MCU_P+	2	28AWG STP-A	C_CLK_MCU_P-	15	28AWG STP-A
C_CMD_MCU_P+	3	28AWG STP-B	C_CMD_MCU_P-	16	28AWG STP-B
C_RES_MCU_P+	4	28AWG STP-C	C_RES_MCU_P-	17	28AWG STP-C
C_RES_SHD	5			18	
	6			19	
	7			20	
D_CLK_MCU_P+	8	28AWG STP-D	D_CLK_MCU_P-	21	28AWG STP-D
D_CLK_SHD	9		D_DAT_MCU_P-	22	28AWG STP-E
D_DAT_MCU_P+	10	28AWG STP-E	D_SHD	23	
D_GAT_MCU_P+	11	28AWG STP-F	D_GAT_MCU_P-	24	28AWG STP-E
D_GAT_SHD	12			25	
	13				
RF Overshield	EMC Backshell-Backshell				

CEA to provide PFM W5 according to Alenia Spazio routing specifications.

4.1.6 W6 - HSDPU-R to HSFCU (MCU)-R

Overall Mechanical Drawing

Geometry specified by Alenia Spazio

1:1 harness of insulated screened 28AWG twisted pairs with backshell to backshell screen, covered on outside with insulation.

Connector/Backshell Details

Redundant Side Harness

DBMA 25 P + Glenair 557 - E - 113 - M - 3 - TBD - H - 0 - TBD to FCUJ2
 DBMA 25 S + Glenair 557 - 103 - M - 3 - TBD - H - 0 - TBD to DPUJ11

Harness Layup

As W1

Contact Details

Wired 1:1 in harness

Signal Name	Pin	Wire	Signal Name	Pin	Wire
C_CLK_SHD	1		C_CMD_SHD	14	
C_CLK_MCU_R+	2	28AWG STP-A	C_CLK_MCU_R-	15	28AWG STP-A
C_CMD_MCU_R+	3	28AWG STP-B	C_CMD_MCU_R-	16	28AWG STP-B
C_RES_MCU_R+	4	28AWG STP-C	C_RES_MCU_R-	17	28AWG STP-C
C_RES_SHD	5			18	
	6			19	
	7			20	
D_CLK_MCU_R+	8	28AWG STP-D	D_CLK_MCU_R-	21	28AWG STP-D
D_CLK_SHD	9		D_DAT_MCU_R-	22	28AWG STP-E
D_DAT_MCU_R+	10	28AWG STP-E	D_SHD	23	
D_GAT_MCU_R+	11	28AWG STP-F	D_GAT_MCU_R-	24	28AWG STP-E
D_GAT_SHD	12			25	
	13				
RF Overshield	EMC Backshell-Backshell				

CEA to provide PFM W6 according to Alenia Spazio routing specifications.

4.1.7 W7 - HSFCU-P to HSDCU-P

Overall Mechanical Drawing

Geometry specified by Alenia Spazio

1:1 harness of insulated screened TBD AWG conductors, backshell to backshell screen, covered on outside with insulation.

Connector/Backshell Details

Prime side secondary power distribution harness

DBMA 25 P + Glenair 550 - E - 039 - M - 3 - TBD - H - 0 - TBD to FCUJ7
 DBMA 25 S + Glenair 550 - E - 039 - M - 3 - TBD - H - 0 - TBD to DCUJ3

Harness Layup

Contact Details

Pin Number	Signal
1	LIA_P_P9V
2	LIA_P_GND9V
3	LIA_P_N9V
4	LIA_S_P9V
5	LIA_S_GND9V
6	LIA_S_N9V
7	PDAQ_P9V
8	PDAQ_GND9V
9	PDAQ_N9V
10	PDAQ_P5V
11	LIA_S_P5V
12	LIA_P_P5V
13	Chassis
14	LIA_P_P9V
15	LIA_P_GND9V
16	LIA_P_N9V
17	LIA_S_P9V
18	LIA_S_GND9V
19	LIA_S_N9V
20	PDAQ_P9V
21	PDAQ_GND9V
22	PDAQ_N9V
23	PDAQ_GND9V
24	LIA_P_GND5V
25	LIA_S_GND5V

CEA to provide PFM W7 according to Alenia Spazio routing specifications.

4.1.8 W8 - HSFCU-R to HSDCU-R

Overall Mechanical Drawing
 Geometry specified by Alenia Spazio
 As per W7

Connector/Backshell Details
 Prime side secondary power distribution harness
 DBMA 25 P + Glenair 550 - E - 039 - M - 3 - TBD - H - 0 - TBD to FCUJ8
 DBMA 25 S + Glenair 550 - E - 039 - M - 3 - TBD - H - 0 - TBD to DCUJ4

Harness Layup
 As W7

Contact Details
 As W7

CEA to provide PFM W8 according to Alenia Spazio routing specifications.

4.2 SVM Cryoharnesses

▪ Conductor wire

The individual conductors for this harness are 28/30 AWG stranded Copper. This gives very low impedance, relevant for the bolometer channels, which would otherwise be susceptible to Johnson noise contributions from this harness.

▪ SVM Harness Shielding

To implement an instrument-grounding scheme consistent with RD-2, the harnesses need to incorporate (among others) the following features:

- (A) An overall bundle shield with full 360° termination at the EMC backshells. (Red)
- (B) Inner shields terminated with a short pig tail to a bonded lug on the DRCU backshells and terminated onto multiple pins on the connector at the SVM Connector Bracket. (Mauve)
- (C) An insulating jacket between the two shields. (Dashed Black)

Figure 4-1 illustrates one particular harness shielding implementation, which is compatible with these requirements.

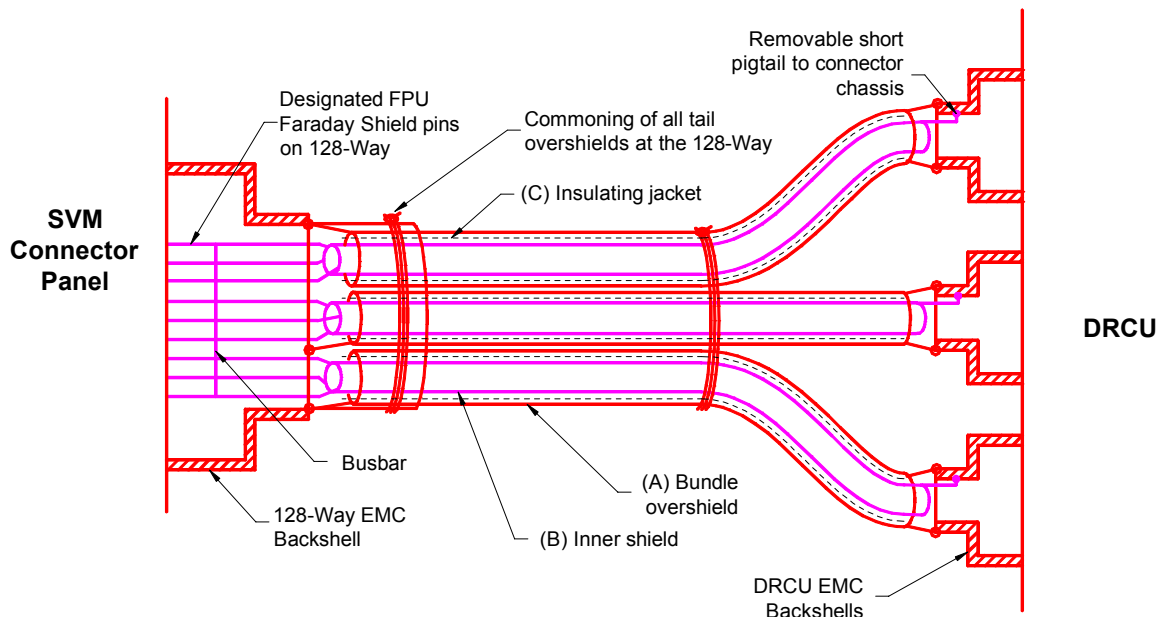
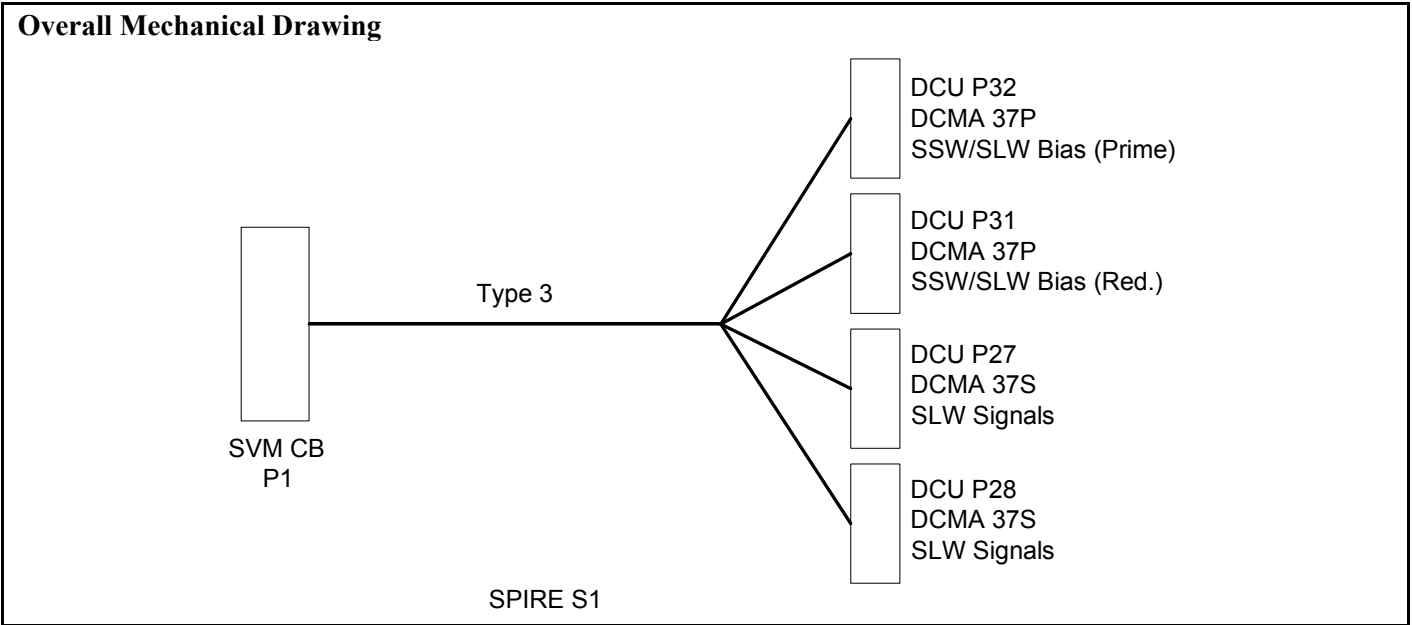

Figure 4-1

4.2.1 S1 SVM-CB 1 – DRCU (Type3) Spectrometer Biases and SLW



Connector/Backshell Details:

DCMA 37 S	+	Glenair557-E-359-M-4to	DCUJ27	DCU-JFS	(End Entry Backshell)
DCMA 37 S	+	Glenair557-B-357-M-4to	DCUJ28	DCU-JFS	(45° Entry Backshell)
DCMA 37 P	+	Glenair557-B-357-M-4to	DCUJ31	Spect. Bias (Prime)	(45° Entry Backshell)
DCMA 37 P	+	Glenair557-B-357-M-4to	DCUJ32	Spect. Bias (Red.)	(45° Entry Backshell)

Note that within the bias tails to DCU P31/P32 the different “BDA” analogue grounds are kept separate.



SPIRE HARNESS DEFINITION DOCUMENT

Doc: SPIRE-RAL-PRJ-000608
Issue: 1.2
Date: 17/02/05
Page 31 of 245

SLW Spectrometer Tail P27 Lay-up

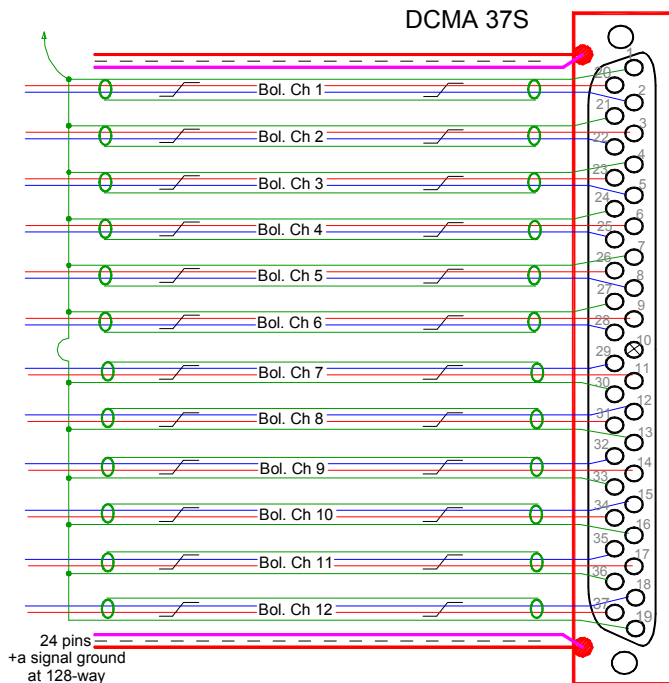

12 Channel Bolometer SLW Tail DCU P27

- 12 Insulated STPs
- 1 Insulated Single Wire
- See Section 4.2 for details regarding the implementation of the shields.
- SLW grounds of P27 and P28 are commoned at the 128-way connector
- No harness bundle overall insulation baselined. May be added later by locally wrapping with insulation at contact points.
- Harness connector is a Socket. Drawing indicates pin allocation as seen from the rear, non-engaging face of the connector.

SLW Spectrometer Tail P28 Lay-up

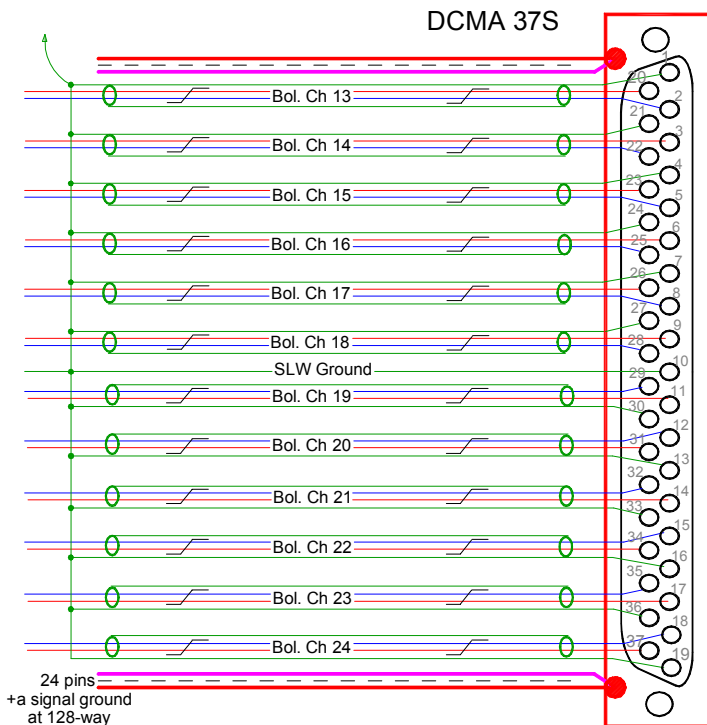

12 Channel Bolometer SLW Tail DCU P28

- 12 Insulated STPs
- 1 Insulated Single Wire
- See Section 4.2 for details regarding the implementation of the shields.
- SLW grounds of P27 and P28 are commoned at the 128-way connector
- No harness bundle overall insulation baselined. May be added later by locally wrapping with insulation at contact points.
- Harness connector is a Socket. Drawing indicates pin allocation as seen from the rear, non-engaging face of the connector.



SPIRE HARNESS DEFINITION DOCUMENT

Doc: SPIRE-RAL-PRJ-000608

Issue: 1.2

Date: 17/02/05

Page 32 of 245

Spectrometer Bias Tails Lay-up (P31/P32)

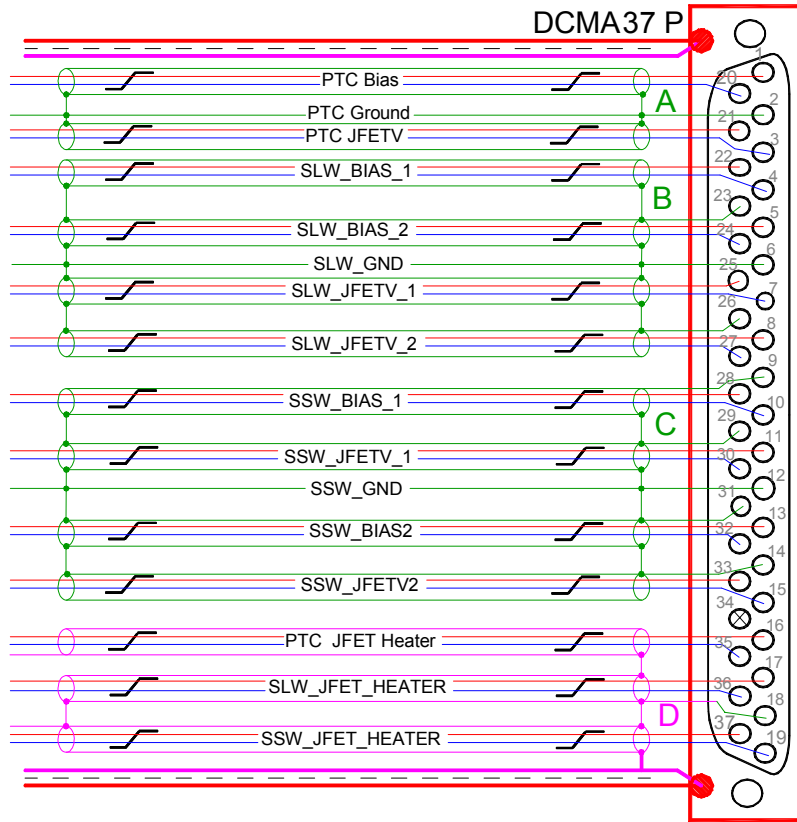

Type 3 Bias Tails (DCU P31/P32)

- 13 Insulated STPs
- 4 Single insulated ground wires
- Note SLW and SSW Ground Separation
- See Section 4.2 for details regarding the implementation of the shields.
- No harness bundle overall insulation baselined. May be added later by locally wrapping with insulation at contact points.
- A, B, C and D represent the commoning of ground references within the connectors which pass through the 128-way SVM-CB connector on single individual pins. The four prime and redundant ground planes are not commoned at the 128-Way connector.



SPIRE HARNESS DEFINITION DOCUMENT

Doc: SPIRE-RAL-PRJ-000608
Issue: 1.2
Date: 17/02/05
Page 33 of 245

SVM-CB S1 128-Way Pin Allocations (View of wiring side of connector)

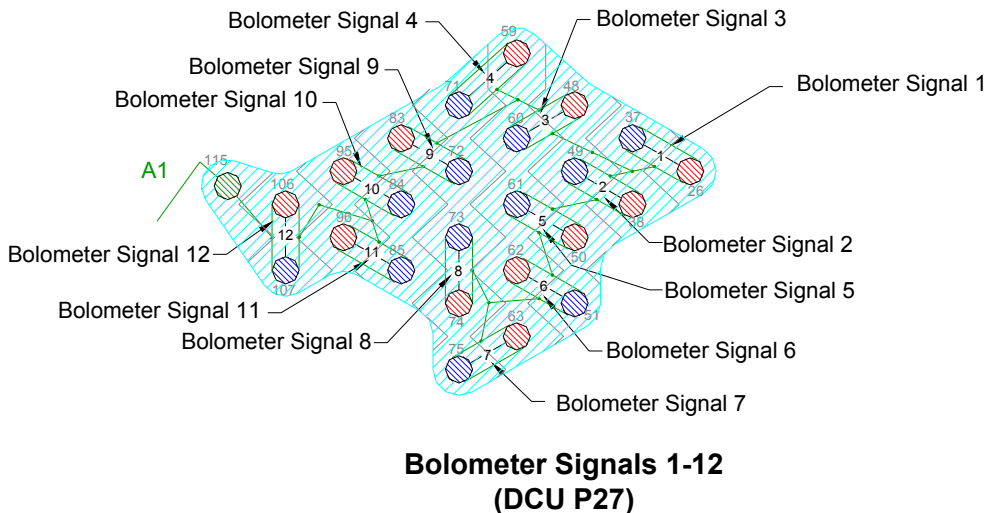
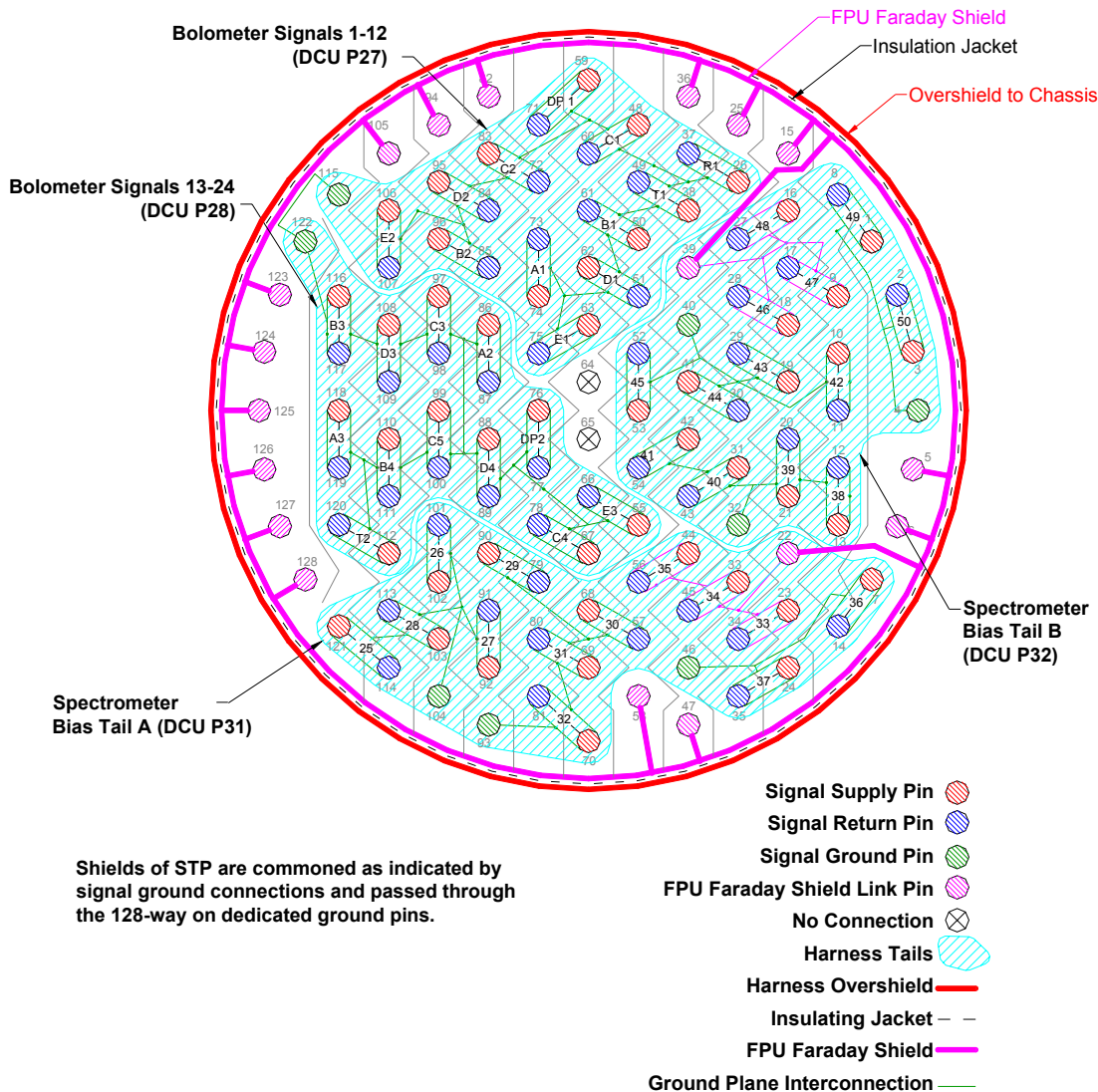



SPIRE HARNESS DEFINITION DOCUMENT

Doc: SPIRE-RAL-PRJ-000608

Issue: 1.2

Date: 17/02/05

Page 34 of 245

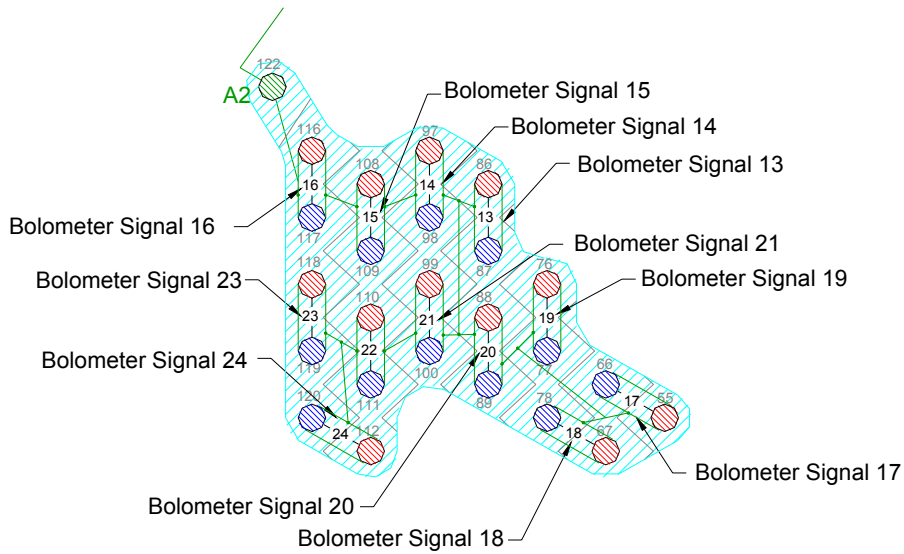

**Bolometer Signals 13-24
(DCU P28)**

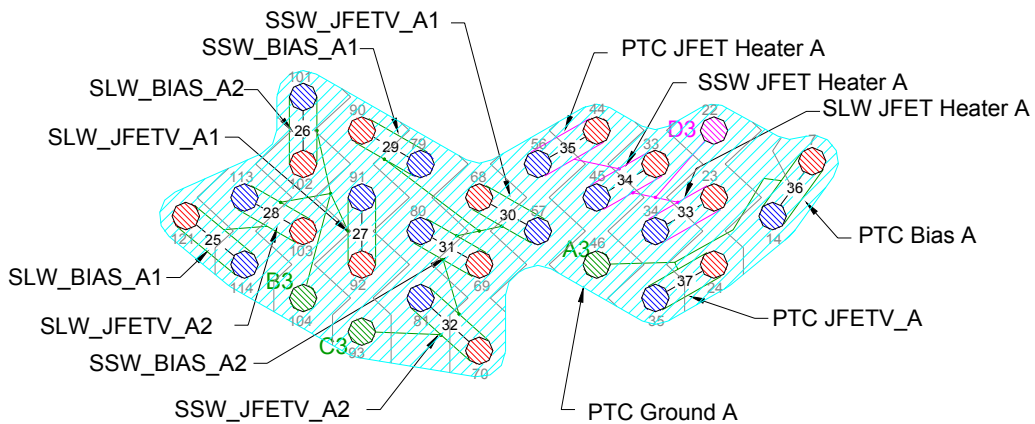

**Spectrometer Bias Tail A
(DCU P31)**



SPIRE HARNESS DEFINITION DOCUMENT

Doc: SPIRE-RAL-PRJ-000608
Issue: 1.2
Date: 17/02/05
Page 35 of 245

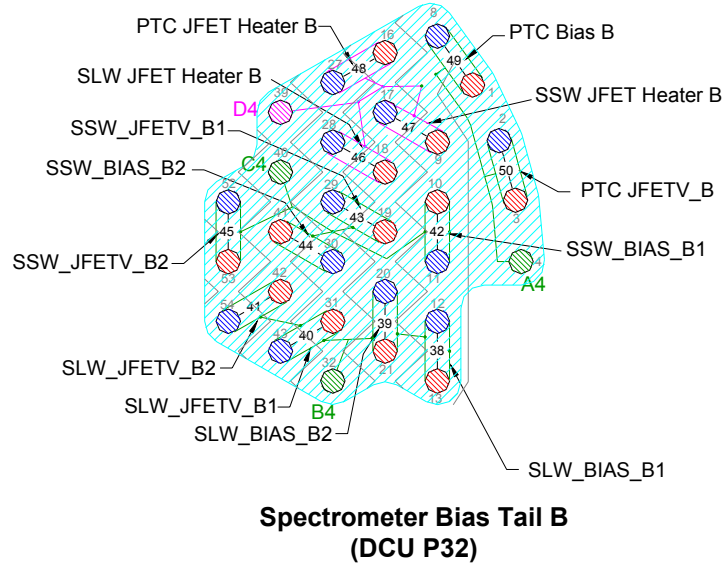

Contact Details

Notes:

1. Pin numbers on the 128-way suffixed by a letter in parentheses indicate the commoning of several ground reference wires or shields within the connector to a single pin on the 128-way CVV connector or the 37-way DCU connector.
2. Ground pins 115 and 122 are commoned within the connector.

Table 4.2-1- SIH-SS-01 Listing

	Name	Function	128-way #1	DCU P27	DCU P28	DCU P31 S. Bias Tail A	DCU P32 S. Bias Tail B
S1-STP-A1	Channel 1 +	SLW-R1	26	20			
	Channel 1 -		37	2			
	Channel 1gnd shld		115 (A1)	1			
S1-STP-A2	Channel 2 +	SLW-T1	38	3			
	Channel 2 -		49	22			
	Channel 2gnd shld		115 (A1)	21			
S1-STP-A3	Channel 3 +	SLW-C1	48	23			
	Channel 3 -		60	5			
	Channel 3gnd shld		115 (A1)	4			
S1-STP-A4	Channel 4 +	SLW-DK1	59	6			
	Channel 4 -		71	25			
	Channel 4gnd shld		115 (A1)	24			
S1-STP-B1	Channel 5 +	SLW-B1	50	26			
	Channel 5 -		61	8			
	Channel 5gnd shld		115 (A1)	7			
S1-STP-B2	Channel 6 +	SLW-D1	62	9			
	Channel 6 -		51	28			
	Channel 6gnd shld		115 (A1)	27			
S1-STP-B3	Channel 7 +	SLW-E1	63	11			
	Channel 7 -		75	29			
	Channel 7gnd shld		115 (A1)	30			



SPIRE HARNESS DEFINITION DOCUMENT

Doc: SPIRE-RAL-PRJ-000608
Issue: 1.2
Date: 17/02/05
Page 36 of 245

	Name	Function	128-way #1	DCU P27	DCU P28	DCU P31 S. Bias Tail A	DCU P32 S. Bias Tail B
S1-STP-B4	Channel 8 +	SLW-A1	74	31			
	Channel 8 -		73	12			
	Channel 8gnd shld		115 (A1)	13			
S1-STP-S1	Channel 9 +	SLW-C2	83	14			
	Channel 9 -		72	32			
	Channel 9gnd shld		115 (A1)	33			
S1-STP-C2	Channel 10 +	SLW-D2	95	34			
	Channel 10 -		84	15			
	Channel 10gnd shld		115 (A1)	16			
S1-STP-C3	Channel 11 +	SLW-B2	96	17			
	Channel 11 -		85	35			
	Channel 11gnd shld		115 (A1)	36			
S1-STP-C4	Channel 12 +	SLW-E2	106	37			
	Channel 12 -		107	18			
	Channel 12gnd shld		115 (A1)	19			
S1-STP-D1	Channel 13 +	SLW-A2	86		20		
	Channel 13 -		87		2		
	Channel 13gnd shld		122 (A2)		1		
S1-STP-D2	Channel 14 +	SLW-C3	97		3		
	Channel 14 -		98		22		
	Channel 14gnd shld		122 (A2)		21		
S1-STP-D3	Channel 15 +	SLW-D3	108		23		
	Channel 15 -		109		5		
	Channel 15gnd shld		122 (A2)		4		
S1-STP-D4	Channel 16 +	SLW-B3	116		6		
	Channel 16 -		117		25		
	Channel 16gnd shld		122 (A2)		24		
S1-STP-E1	Channel 17 +	SLW-E3	55		26		
	Channel 17 -		66		8		
	Channel 17gnd shld		122 (A2)		7		
S1-STP-E2	Channel 18 +	SLW-C4	67		9		
	Channel 18 -		78		28		
	Channel 18gnd shld		122 (A2)		27		
	SLW GND WIRE	SLW_GND	122 (A2)		10		
S1-STP-E3	Channel 19 +	SLW-DK2	76		11		
	Channel 19 -		77		29		
	Channel 19gnd shld		122 (A2)		30		
S1-STP-E4	Channel 20 +	SLW-D4	88		31		
	Channel 20 -		89		12		
	Channel 20gnd shld		122 (A2)		13		
S1-STP-F1	Channel 21 +	SLW-C5	99		14		
	Channel 21 -		100		32		
	Channel 21gnd shld		122 (A2)		33		
S1-STP-F2	Channel 22 +	SLW-B4	110		34		
	Channel 22 -		111		15		
	Channel 22gnd shld		122 (A2)		16		
S1-STP-F3	Channel 23 +	SLW-A3	118		17		
	Channel 23 -		119		35		
	Channel 23gnd shld		122 (A2)		36		
S1-STP-F4	Channel 24 +	SLW-T2	112		37		
	Channel 24 -		120		18		
	Channel 24gnd shld		122 (A2)		19		
	PTC Bias_A +ve	PBias_TC	7			1	



SPIRE HARNESS DEFINITION DOCUMENT

Doc: SPIRE-RAL-PRJ-000608
Issue: 1.2
Date: 17/02/05
Page 37 of 245

Name	Function	128-way #1	DCU P27	DCU P28	DCU P31 S. Bias Tail A	DCU P32 S. Bias Tail B
PTC Bias_A -ve	Nbias_TC	14			20	
PTC Bias_A Shield	Gnd_Bias_Ph	46 (A3)			2 (A)	
PTC Ground_A	Gnd_Bias_Ph	46 (A3)			2 (A)	
PTC JFETV Bias_A +ve	Vdd_TC	24			21	
PTC JFETV Bias_A -ve	Vss_TC	35			3	
PTC JFETV Bias_A Shield	Gnd_Bias_Ph	46 (A3)			2 (A)	
SLW_BIAS_A1+ve	Pbias_SLW	121			22	
SLW_BIAS_A1-ve	Nbias_SLW	114			4	
SLW_BIAS_A1 shld	SLW_Gnd_Shds	104 (B3)			6 (B)	
SLW_BIAS_A2 +ve	Pbias_SLW	102			5	
SLW_BIAS_A2 -ve	Nbias_SLW	101			24	
SLW_BIAS_A2 shld	Bias_SLW_Shld	104 (B3)			23 (B)	
SLW GND WIRE_A	SLW_Gnd_Shds	104 (B3)			6 (B)	
SLW_JFETV_A1 +ve	Vdd1_S	92			25	
SLW_JFETV_A1 -ve	Vss1_S	91			7	
SLW_JFETV_A1 shld	SLW_Gnd_Shds	104 (B3)			6 (B)	
SLW_JFETV_A2 +ve	Vdd1_S	103			8	
SLW_JFETV_A2 -ve	Vss1_S	113			27	
SLW_JFETV_A2 shld	SLW_Gnd_Shds	104 (B3)			6 (B)	
SSW_BIAS1_A +ve	Pbias_SSW	90			28	
SSW_BIAS1_A -ve	Nbias_SSW	79			10	
SSW_BIAS1_A shld	Bias_SSW_shld	93 (C3)			9 (C)	
SSW_JFETV1_A +ve	Vdd2_S	68			11	
SSW_JFETV1_A -ve	Vss2_S	57			30	
SSW_JFETV1_A shld	Vdd2_Vss2_S_shld	93 (C3)			29 (C)	
SSW GND WIRE_A	SSW_Gnd	93 (C3)			12 (C)	
SSW_BIAS2_A +ve	Pbias_SSW	69			13	
SSW_BIAS2_A -ve	Nbias_SSW	80			32	
SSW_BIAS2_A shld	Bias_SSW_Shld	93 (C3)			31 (C)	
SSW_JFETV2_A +ve	Vdd3_S	70			33	
SSW_JFETV2_A -ve	Vss3_S	81			15	
SSW_JFETV2_A shld	Vdd_Vss_S_Shld	93 (C3)			14 (C)	
S_HEATER GROUND PIN_A		22 (D3)			NC	
SLW_JFET_HEATER_A +ve	Pheater_SLW	23			17	
SLW_JFET_HEATER_A -ve	Nheater_SLW	34			36	
SLW_JFET_HEATER_A shld	Heater_SSW_shld	22 (D3)			Backshell (D)	
SSW_JFET_HEATER_A +ve	Pheater_SSW	33			37	
SSW_JFET_HEATER_A -ve	Nheater_SSW	45			19	
SSW_JFET_HEATER_A shld	Heater_SSW_shld	22 (D3)			Backshell (D)	
PTC JFET HEATER_A +ve	Pheater_TC	44			16	
PTC JFET HEATER_A -ve	Nheater_TC	56			35	
PTC JFET HEATER_A shld		22(D3)			Backshell (D)	
PTC Bias_B +ve	PBias_TC	1				1
PTC Bias_B -ve	Nbias_TC	8				20
PTC Bias_B Shield	Gnd_Bias_Ph	4 (A4)				2 (A)
PTC Ground_B	Gnd_Bias_Ph	4 (A4)				2 (A)
PTC JFETV Bias_B +ve	Vdd_TC	3				21
PTC JFETV Bias_B -ve	Vss_TC	2				3
PTC JFETV Bias_B Shield	Gnd_Bias_Ph	4 (A4)				2 (A)
SLW_BIAS_B1+ve	Pbias_SLW	13				22
SLW_BIAS_B1-ve	Nbias_SLW	12				4



SPIRE HARNESS DEFINITION DOCUMENT

Doc: SPIRE-RAL-PRJ-000608
Issue: 1.2
Date: 17/02/05
Page 38 of 245

Name	Function	128-way #1	DCU P27	DCU P28	DCU P31 S. Bias Tail A	DCU P32 S. Bias Tail B
SLW_BIAS_B1 shld	SLW_Gnd_Shds	32 (B4)				6 (B)
SLW_BIAS_B2 +ve	Pbias_SLW	21				5
SLW_BIAS_B2 -ve	Nbias_SLW	20				24
SLW_BIAS_B2 shld	Bias_SLW_Shld	32 (B4)				23 (B)
SLW_JFETV_B1 +ve	Vdd1_S	31				25
SLW_JFETV_B1 -ve	Vss1_S	43				7
SLW_JFETV_B1 shld	SLW_Gnd_Shds	32 (B4)				6 (B)
SLW_JFETV_B2 +ve	Vdd1_S	42				8
SLW_JFETV_B2 -ve	Vss1_S	54				27
SLW_JFETV_B2 shld	SLW_Gnd_Shds	32 (B4)				6 (B)
SLW_GND WIRE_B	SLW_Gnd_Shds	32 (B4)				6 (B)
SSW_GND WIRE_B	SSW_Gnd	40 (C4)				12 (C)
SSW_BIAS1_B +ve	Pbias_SSW	10				28
SSW_BIAS1_B -ve	Nbias_SSW	11				10
SSW_BIAS1_B shld	Bias_SSW_shld	40 (C4)				9 (C)
SSW_JFETV1_B +ve	Vdd2_S	19				11
SSW_JFETV1_B -ve	Vss2_S	29				30
SSW_JFETV1_B shld	Vdd2_Vss2_S_shld	40 (C4)				29 (C)
SSW_BIAS2_B +ve	SSW_Gnd	41				13
SSW_BIAS2_B -ve	Pbias_SSW	30				32
SSW_BIAS2_B shld	Nbias_SSW	40 (C4)				31 (C)
SSW_JFETV2_B +ve	Bias_SSW_Shld	53				33
SSW_JFETV2_B -ve	Vdd3_S	52				15
SSW_JFETV2_B shld	Vss3_S	40 (C4)				14 (C)
S_HEATER GROUND PIN B	Vdd_Vss_S_Shld	39 (D4)				NC
SLW_HEATER_B +ve	Pheater_SLW	18				17
SLW_HEATER_B -ve	Nheater_SLW	28				36
SLW_HEATER_B shld	Heater_SSW_shld	39 (D4)				Backshell (D)
SSW_HEATER_B +ve	Pheater_SSW	9				37
SSW_HEATER_B -ve	Nheater_SSW	17				19
SSW_HEATER_B shld	Heater_SSW_shld	39 (D4)				Backshell (D)
PTC JFET_HEATER_A +ve	Pheater_TC	16				16
PTC JFET_HEATER_A -ve	Nheater_TC	27				35
PTC JFET_HEATER_A shld		39 (D4)				Backshell (D)
Harness Overshield		EMC Backshell	EMC Backshell	EMC Backshell	EMC Backshell	EMC Backshell

FPU Faraday Shield Link Pins S1/I1/C1								
5	6	15	22	25	36	39	47	58
82	94	105	123	124	125	126	127	128



SPIRE HARNESS DEFINITION DOCUMENT

Doc: SPIRE-RAL-PRJ-000608
Issue: 1.2
Date: 17/02/05
Page 39 of 245

4.2.2 S2 SVM-CB 2 – DRCU (Type 4) SSW and PTC

Overall Mechanical Drawing

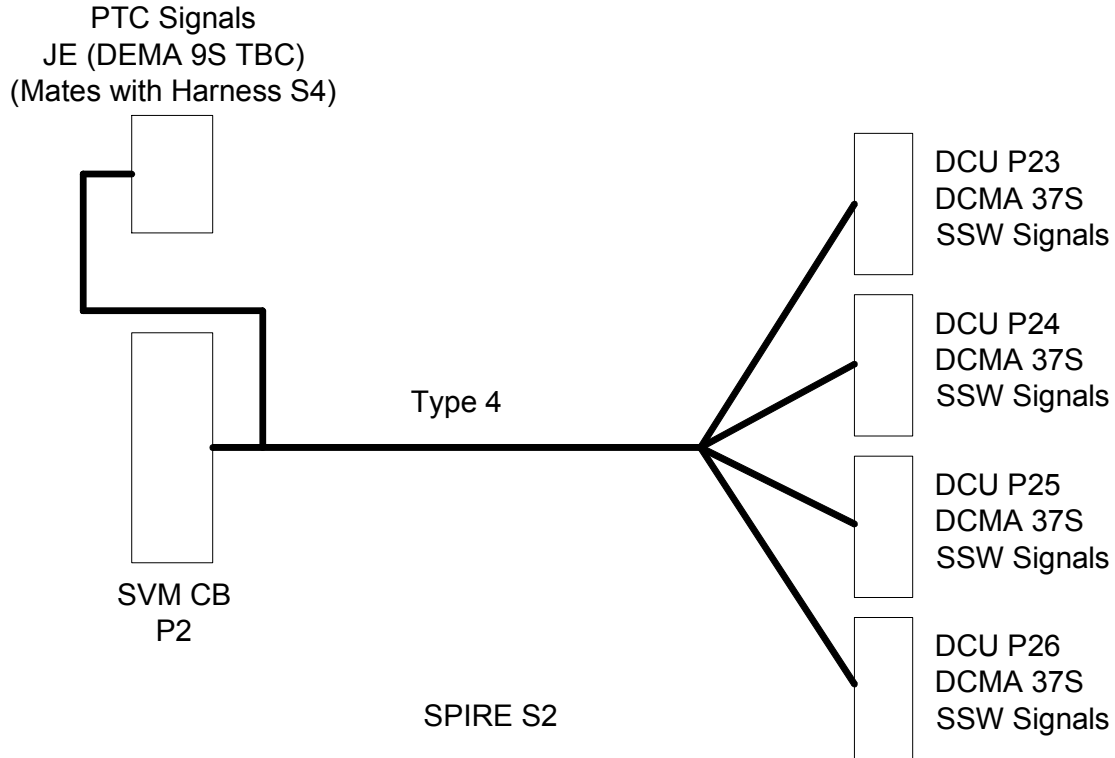

Refer to Annex 7 for details of how the S2 and the S4 harnesses readout the PTC Signals within the photometer LIAs.

Connector/Backshell Details

DCMA 37 S	+	Glenair 557-E-359-M-4	to	DCUJ23	DCU-JFS	(End Entry Backshell)
DCMA 37 S	+	Glenair 557-B-357-M-4	to	DCUJ24	DCU-JFS	(45° entry Backshell)
DCMA 37 S	+	Glenair 557-E-359-M-4	to	DCUJ25	DCU-JFS	(End Entry Backshell)
DCMA 37 S	+	Glenair 557-B-357-M-4	to	DCUJ26	DCU-JFS	(45° entry Backshell)
DEMA 9 S	+	Glenair 557-?- ? M-1	to	S4PE	J2-J4	(Top entry backshell?)



SPIRE HARNESS DEFINITION DOCUMENT

Doc: SPIRE-RAL-PRJ-000608
Issue: 1.2
Date: 17/02/05
Page 40 of 245

SSW Bolometer Tails Lay-up (P23/P25)

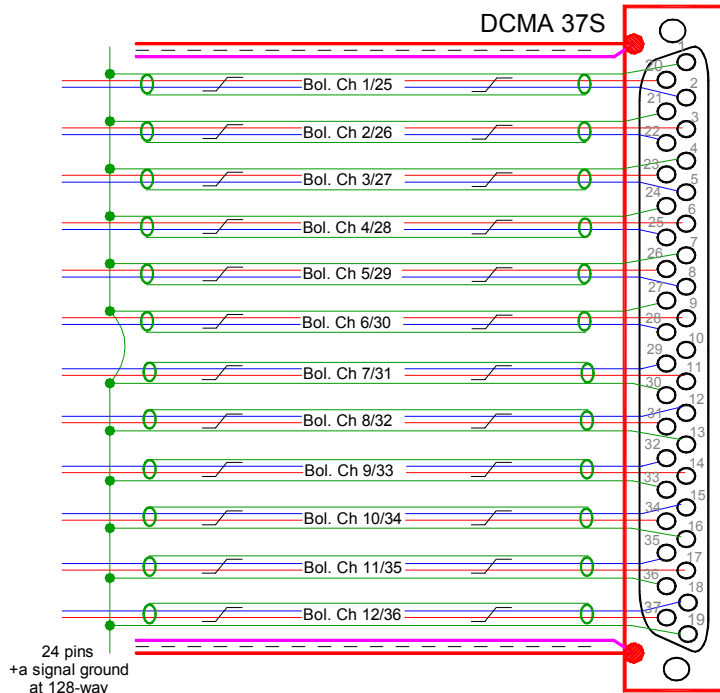

12 Channel Bolometer SSW Tails (DCU P23/P25)

- 12 Insulated STPs
- 1 Insulated Single Wire
- P23 Carries bolometer signals 1-12
- P25 Carries bolometer signals 25-36
- See Section 4.2 for details regarding the implementation of the shields.
- FPU Faraday Shield Link Wires of P23 and P25 are commoned at the 128-way connector
- No harness bundle overall insulation baselined. May be added later by locally wrapping with insulation at contact points.
- Harness connector is a Socket. Drawing indicates pin allocation as seen from the rear, non-engaging face of the connector.

SSW Bolometer Tail Lay-up (DCU P24)

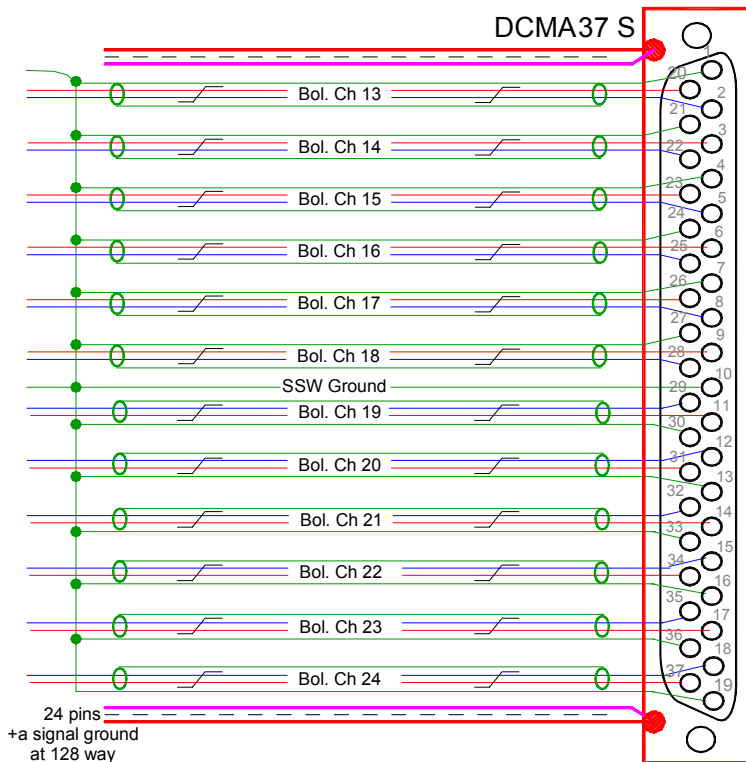

12 Channel Bolometer SSW Tail (DCU P24)

- 12 Insulated STPs
- 1 Insulated Single Wire
- See Section 4.2 for details regarding the implementation of the shields.
- SSW Grounds of P24 and P26 are commoned at the 128-way connector
- No harness bundle overall insulation baselined. May be added later by locally wrapping with insulation at contact points.
- Harness connector is a Socket. Drawing indicates pin allocation as seen from the rear, non-engaging face of the connector.



SPIRE HARNESS DEFINITION DOCUMENT

Doc: SPIRE-RAL-PRJ-000608
 Issue: 1.2
 Date: 17/02/05
 Page 41 of 245

SSW Bolometer Tail Lay-up (DCU P26)

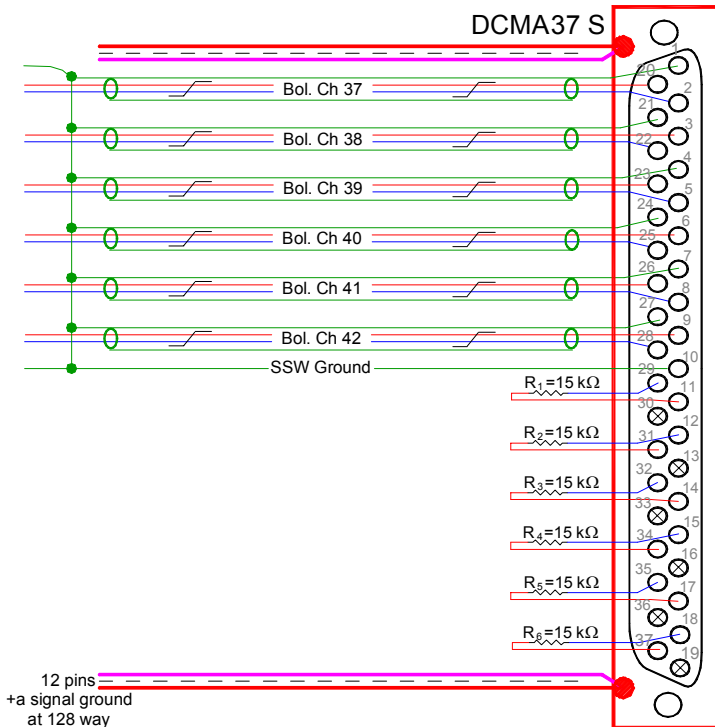

12 Channel Bolometer SSW Tail (DCU P26)

- 6 Insulated STPs
- 1 Insulated Single Wire
- P26 Carries bolometer signals 37-42
- See Section 4.2 for details regarding the implementation of the shields.
- SSW Ground Wires of P24 and P26 are commoned at the 128-way connector
- No harness bundle overall insulation baselined. May be added later by locally wrapping with insulation at contact points.
- Harness connector is a Socket. Drawing indicates pin allocation as seen from the rear, non-engaging face of the connector.
- 15k Ω Resistors to short out channels 43-48

PTC Signals JE:

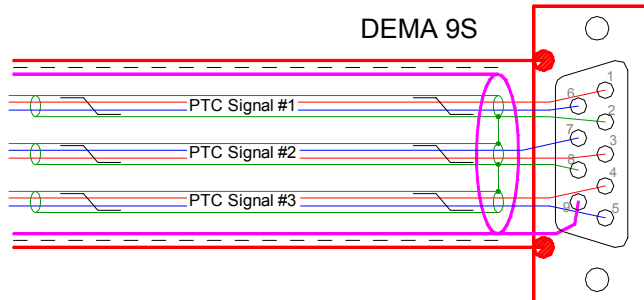

Photometer Thermal Control Signals (JE)

- 3 Insulated STPs
- See Section 4.2 for details regarding the implementation of the shields.
- No harness bundle overall insulation baselined. May be added later by locally wrapping with insulation at contact points.
- Harness connector is a Socket. Drawing indicates pin allocation as seen from the rear, non-engaging face of the connector.

See Footnote²:

² Do to an error in the design of the ground test harness (HSJFS J7); an intermediate harness needs to be inserted between JE and JP (on S4) that inverts the polarity of PTC Signal #3 and . No such correction is needed for the flight harness.



SPIRE HARNESS DEFINITION DOCUMENT

Doc: SPIRE-RAL-PRJ-000608

Issue: 1.2

Date: 17/02/05

Page 42 of 245

SVM-CB S2 128-Way Pin Allocation (View of wiring side of connector)

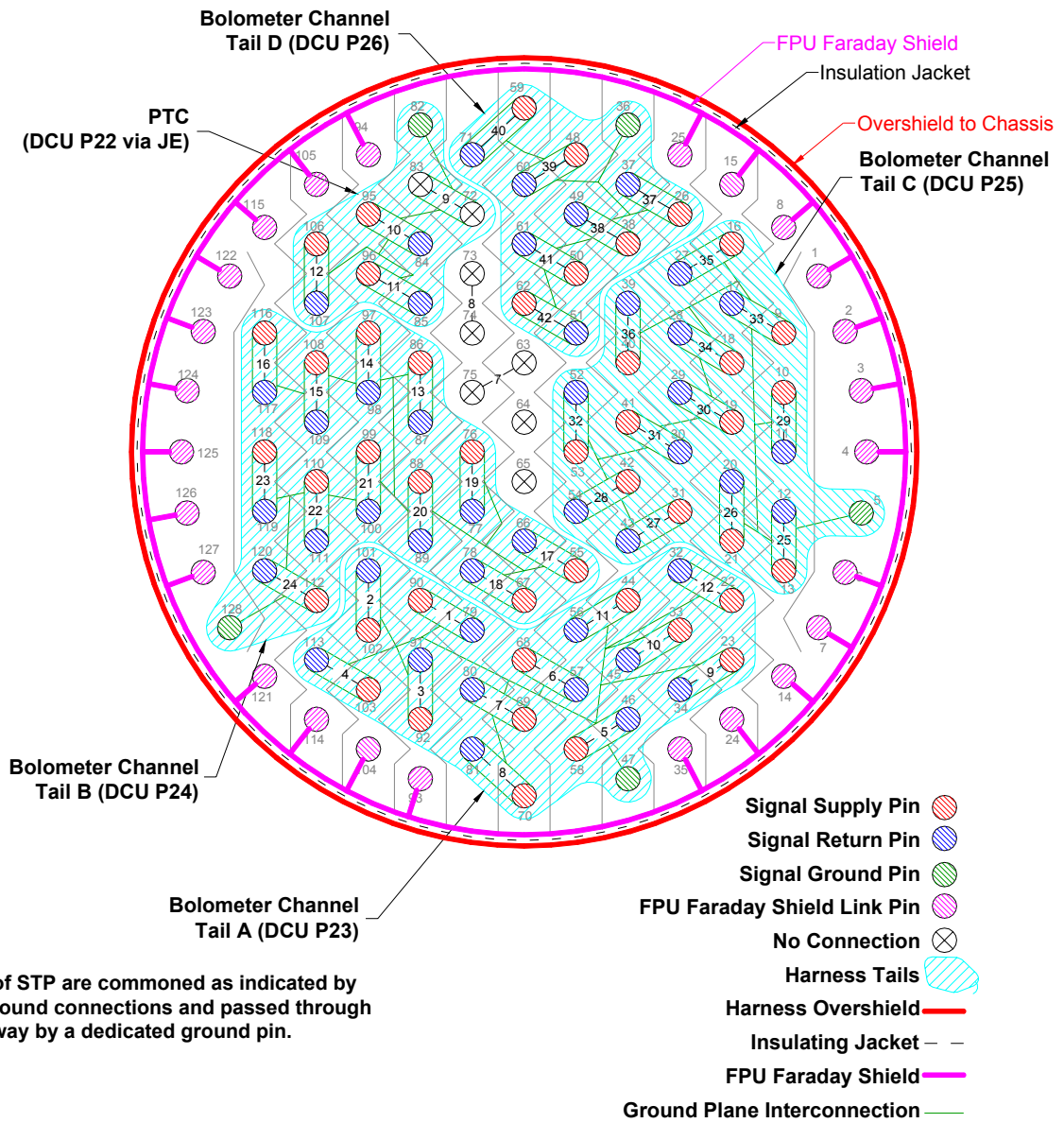



SPIRE HARNESS DEFINITION DOCUMENT

Doc: SPIRE-RAL-PRJ-000608
Issue: 1.2
Date: 17/02/05
Page 43 of 245

SVM-CB S2 128-Way Pin Allocation (cont.)

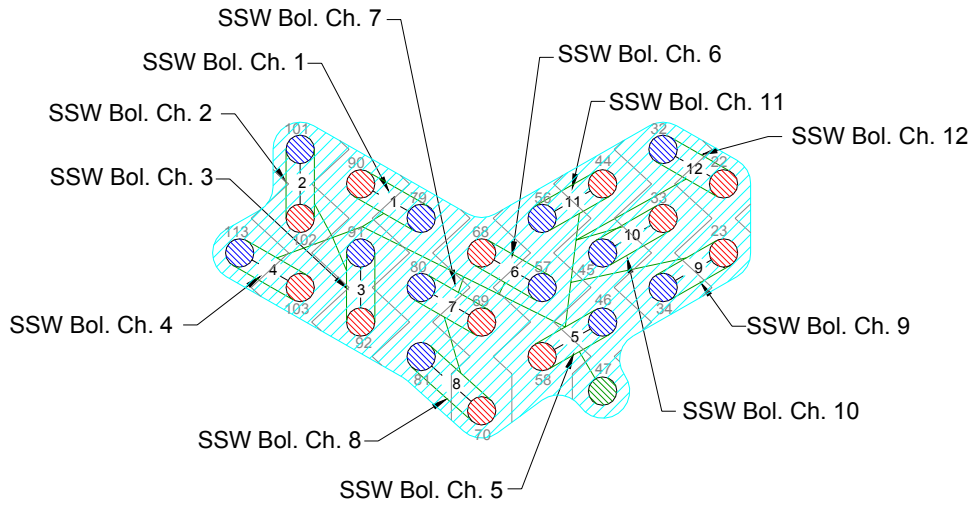

Bolometer Channel Tail A (DCU P23)

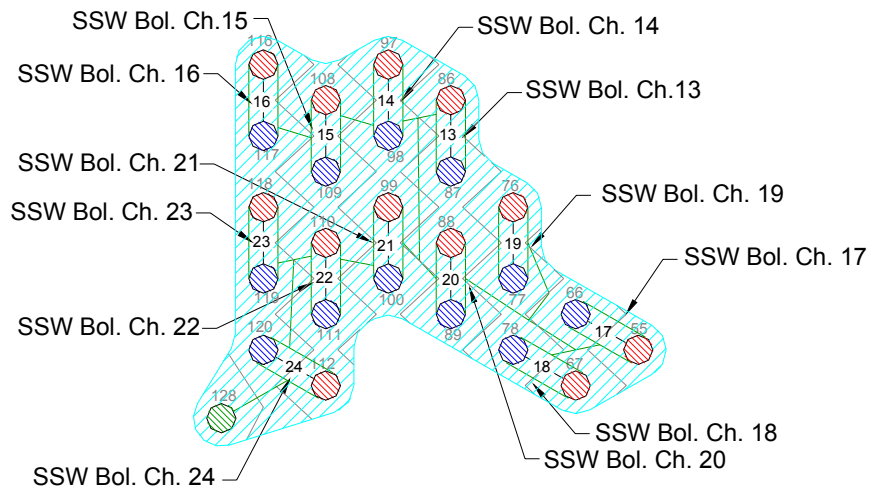

Bolometer Channel Tail B (DCU P24)

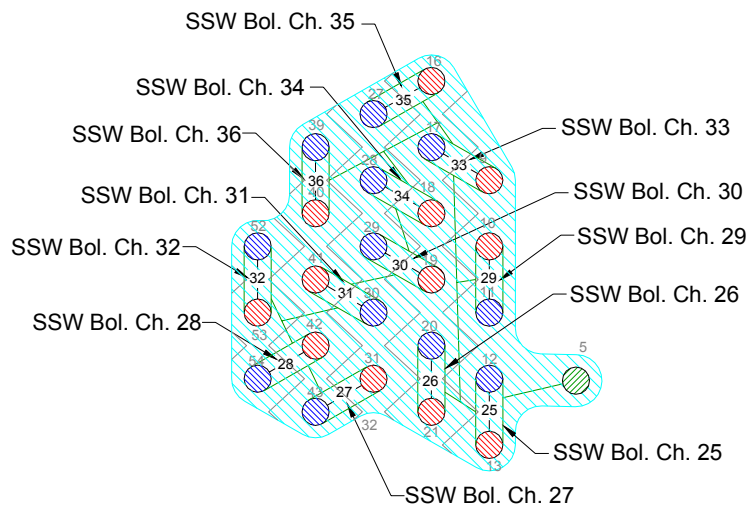

Bolometer Channel Tail C (DCU P25)



SPIRE HARNESS DEFINITION DOCUMENT

Doc: SPIRE-RAL-PRJ-000608
Issue: 1.2
Date: 17/02/05
Page 44 of 245

SVM-CB S2 128-Way Pin Allocation (cont.)

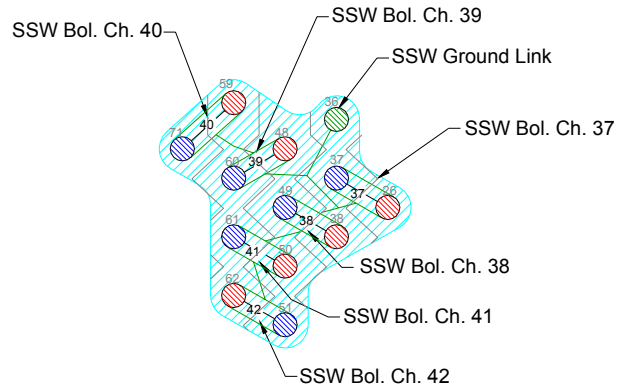

Bolometer Channel Tail D (DCU P26)

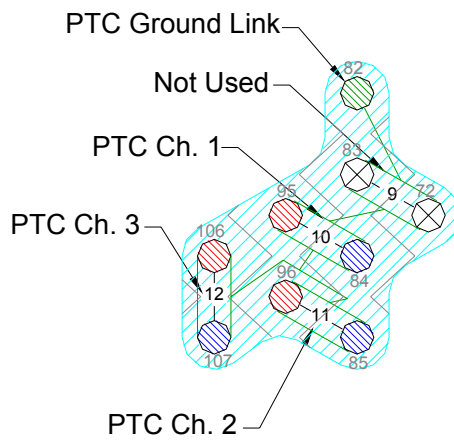

**PTC
DCU P22 via JE**

Contact Details

Notes:

A. Pin numbers on the 128-way suffixed by a letter in parentheses indicate the commoning of several ground reference wires or shields within the connector to a single pin on the 128-way CVV connector or the 37-way DCU connector.

B. Pin numbers for connector JE assume the use of a DEMA 9 connector.

C. Refer to Annex 7 - PTC Cryoharnessing that indicates graphically the means by which these signals are wired.

D. The FPU Faraday Shield Link passes through JE/PE on Pin 9

Table 4.2-2 - SIH-SS-02 Listing

	Name		128Way #2	37-Way DCU P23	37-Way DCU P24	37-Way DCU P25	37-Way DCU P26	SVM-CB JE (I/F S2/S4)
S2-STP-G1	Channel 1 +	SSW-R1	90	20				
	Channel 1 -		79	2				
	Channel 1gnd shld		47 (C)	1				
S2-STP-G2	Channel 2 +	SSW-A4	102	3				
	Channel 2 -		101	22				
	Channel 2gnd shld		47 (C)	21				
S2-STP-G3	Channel 3 +	SSW-A3	92	23				
	Channel 3 -		91	5				
	Channel 3gnd shld		47 (C)	4				
S2-STP-G4	Channel 4 +	SSW-A2	103	6				
	Channel 4 -		113	25				
	Channel 4gnd shld		47 (C)	24				
S2-STP-H1	Channel 5 +	SSW-A1	58	26				
	Channel 5 -		46	8				
	Channel 5gnd shld		47 (C)	7				
S2-STP-H2	Channel 6 +	SSW-DK1	68	9				
	Channel 6 -		57	28				
	Channel 6gnd shld		47 (C)	27				
S2-STP-H3	Channel 7 +	SSW-B3	69	11				
	Channel 7 -		80	29				
	Channel 7gnd shld		47 (C)	30				
S2-STP-H4	Channel 8 +	SSW-B2	70	31				
	Channel 8 -		81	12				
	Channel 8gnd shld		47 (C)	13				
S2-STP-I1	Channel 9 +	SSW-B1	23	14				
	Channel 9 -		34	32				
	Channel 9gnd shld		47 (C)	33				
S2-STP-I2	Channel 10 +	SSW-C3	33	34				
	Channel 10 -		45	15				
	Channel 10gnd shld		47 (C)	16				
S2-STP-I3	Channel 11 +	SSW-C2	44	17				
	Channel 11 -		56	35				
	Channel 11gnd shld		47 (C)	36				
S2-STP-I4	Channel 12 +	SSW-C1	22	37				
	Channel 12 -		32	18				
	Channel 12gnd shld		47 (C)	19				
S2-STP-J1	Channel 13 +	SSW-D3	86		20			
	Channel 13 -		87	2				
	Channel 13 gnd shld		128 (B)	1				
S2-STP-J2	Channel 14 +	SSW-D2	97		3			
	Channel 14 -		98	22				
	Channel 14 gnd shld		128 (B)	21				
S2-STP-J3	Channel 15 +	SSW-D1	108		23			
	Channel 15 -		109	5				
	Channel 15gnd shld		128 (B)	4				
S2-STP-J4	Channel 16 +	SSW-E3	116		6			
	Channel 16 -		117	25				
	Channel 16gnd shld		128 (B)	24				
S2-STP-K1	Channel 17 +	SSW-E2	55		26			



SPIRE HARNESS DEFINITION DOCUMENT

Doc: SPIRE-RAL-PRJ-000608
Issue: 1.2
Date: 17/02/05
Page 46 of 245

	Name		128Way #2	37-Way DCU P23	37-Way DCU P24	37-Way DCU P25	37-Way DCU P26	SVM-CB JE (I/F S2/S4)
	Channel 17 -		66		8			
	Channel 17gnd shld		128 (B)		7			
S2-STP-K2	Channel 18 +	SSW-E1	67		9			
	Channel 18 -		78		28			
	Channel 18gnd shld		128 (B)		27			
	GND WIRE		128 (B)		10			
S2-STP-K3	Channel 19 +	SSW-F3	76		11			
	Channel 19 -		77		29			
	Channel 19gnd shld		128 (B)		30			
S2-STP-K4	Channel 20 +	SSW-F2	88		31			
	Channel 20 -		89		12			
	Channel 20 gnd shld		128 (B)		13			
S2-STP-L1	Channel 21 +	SSW-F1	99		14			
	Channel 21 -		100		32			
	Channel 21gnd shld		128 (B)		33			
S2-STP-L2	Channel 22 +	SSW-G1	110		34			
	Channel 22 -		111		15			
	Channel 22gnd shld		128 (B)		16			
S2-STP-L3	Channel 23 +	SSW-T1	118		17			
	Channel 23 -		119		35			
	Channel 23gnd shld		128 (B)		36			
S2-STP-L4	Channel 24 +	SSW-G2	112		37			
	Channel 24 -		120		18			
	Channel 24gnd shld		128 (B)		19			
S2-STP-D1	Channel 25 +	SSW-E5	13			20		
	Channel 25 -		12			2		
	Channel 25gnd shld		5 (D)			1		
S2-STP-D2	Channel 26 +	SSW-E4	21			3		
	Channel 26 -		20			22		
	Channel 26gnd shld		5 (D)			21		
S2-STP-D3	Channel 27 +	SSW-D7	31			23		
	Channel 27 -		43			5		
	Channel 27gnd shld		5 (D)			4		
S2-STP-D4	Channel 28 +	SSW-D6	42			6		
	Channel 28 -		54			25		
	Channel 28gnd shld		5 (D)			24		
S2-STP-E1	Channel 29 +	SSW-D5	10			26		
	Channel 29 -		11			8		
	Channel 29gnd shld		5 (D)			7		
S2-STP-E2	Channel 30 +	SSW-D4	19			9		
	Channel 30 -		29			28		
	Channel 30 gnd shld		5 (D)			27		
S2-STP-E3	Channel 31 +	SSW-C6	41			11		
	Channel 31 -		30			29		
	Channel 31gnd shld		5 (D)			30		
S2-STP-E4	Channel 32 +	SSW-C5	53			31		
	Channel 32 -		52			12		
	Channel 32gnd shld		5 (D)			13		
S2-STP-F1	Channel 33 +	SSW-C4	9			14		
	Channel 33 -		17			32		
	Channel 33gnd shld		5 (D)			33		
S2-STP-F2	Channel 34 +	SSW-B5	18			34		
	Channel 34 -		28			15		
	Channel 34gnd shld		5 (D)			16		
S2-STP-F3	Channel 35 +	SSW-B4	16			17		
	Channel 35 -		27			35		
	Channel 35gnd shld		5 (D)			36		
S2-STP-F4	Channel 36 +	SSW-T2	40			37		
	Channel 36 -		39			18		
	Channel 36gnd shld		5 (D)			19		
S2-STP-B3	Channel 37 +	SSW-G3	26				20	
	Channel 37 -		37				2	
	Channel 37gnd shld		36 (A)				1	
S2-STP-B4	Channel 38 +	SSW-G4	38				3	
	Channel 38 -		49				22	
	Channel 38gnd shld		36 (A)				21	
S2-STP-C1	Channel 39 +	SSW-DK2	48				23	
	Channel 39 -		60				5	
	Channel 39gnd shld		36 (A)				4	
S2-STP-C2	Channel 40 +	SSW-F5	59				6	



SPIRE HARNESS DEFINITION DOCUMENT

Doc: SPIRE-RAL-PRJ-000608
Issue: 1.2
Date: 17/02/05
Page 47 of 245

	Name		128Way #2	37-Way DCU P23	37-Way DCU P24	37-Way DCU P25	37-Way DCU P26	SVM-CB JE (I/F S2/S4)
	Channel 40 -		71				25	
	Channel 40gnd shld		36 (A)				24	
S2-STP-C3	Channel 41 +	SSW-F4	50				26	
	Channel 41 -		61				8	
	Channel 41gnd shld		36 (A)				7	
S2-STP-C4	Channel 42 +	SSW-E6	62				9	
	Channel 42 -		51				28	
	Channel 42gnd shld		36 (A)				27	
	GND WIRE		36 (A)				10	
15kΩ	Channel 43 +	Spare	NC				11 to 29 via	
	Channel 43 -		NC				R ₁ =15kΩ	
	Channel 43 gnd shld		NC				30 (N.C.)	
15kΩ	Channel 44 +	Spare	NC				31 to 12 via	
	Channel 44 -		NC				R ₂ =15kΩ	
	Channel 44 gnd shld		NC				13 (N.C.)	
15kΩ	Channel 45 +	Spare	NC				14 to 32 via	
	Channel 45 -		NC				R ₃ =15kΩ	
	Channel 45 gnd shld		NC				33 (N.C.)	
15kΩ	Channel 46 +	Spare	NC				34 to 15 via	
	Channel 46 -		NC				R ₄ =15kΩ	
	Channel 46 gnd shld		NC				16 (N.C.)	
15kΩ	Channel 47 +	Spare	NC				17 to 35 via	
	Channel 47 -		NC				R ₅ =15kΩ	
	Channel 47 gnd shld		NC				36 (N.C.)	
15kΩ	Channel 48 +	Spare	NC				37 to 18 via	
	Channel 48 -		NC				R ₆ =15kΩ	
	Channel 48 gnd shld		NC				19 (N.C.)	
S2-STP-PTC1	PTC Ch 1 +	PTC-1	95					1
	PTC Ch 1 -		84					6
	PTC Gnd		82 (A)					2 (A)
S2-STP-PTC2	PTC Ch 2 +	PTC-2	96					3
	PTC Ch 2 -		85					7
	PTC Gnd		82 (A)					8(A)
S2-STP-PTC3	PTC Ch 3 +	PTC-3	106					4
	PTC Ch 3 -		107					5
	PTC Gnd		82 (A)					8(A)
	Harness Overshield		EMC Backshell	EMC Backshell	EMC Backshell	EMC Backshell	EMC Backshell	EMC Backshell

FPU Faraday Shield Link Pins C2/S2												
1	2	3	5	6	7	8	14	15	24	25	35	93
94	104	105	114	115	121	122	123	124	125	126	127	X



SPIRE HARNESS DEFINITION DOCUMENT

Doc: SPIRE-RAL-PRJ-000608
Issue: 1.2
Date: 17/02/05
Page 48 of 245

4.2.3 S3 SVM-CB 3 – DRCU (Type 2) Photometer Biases

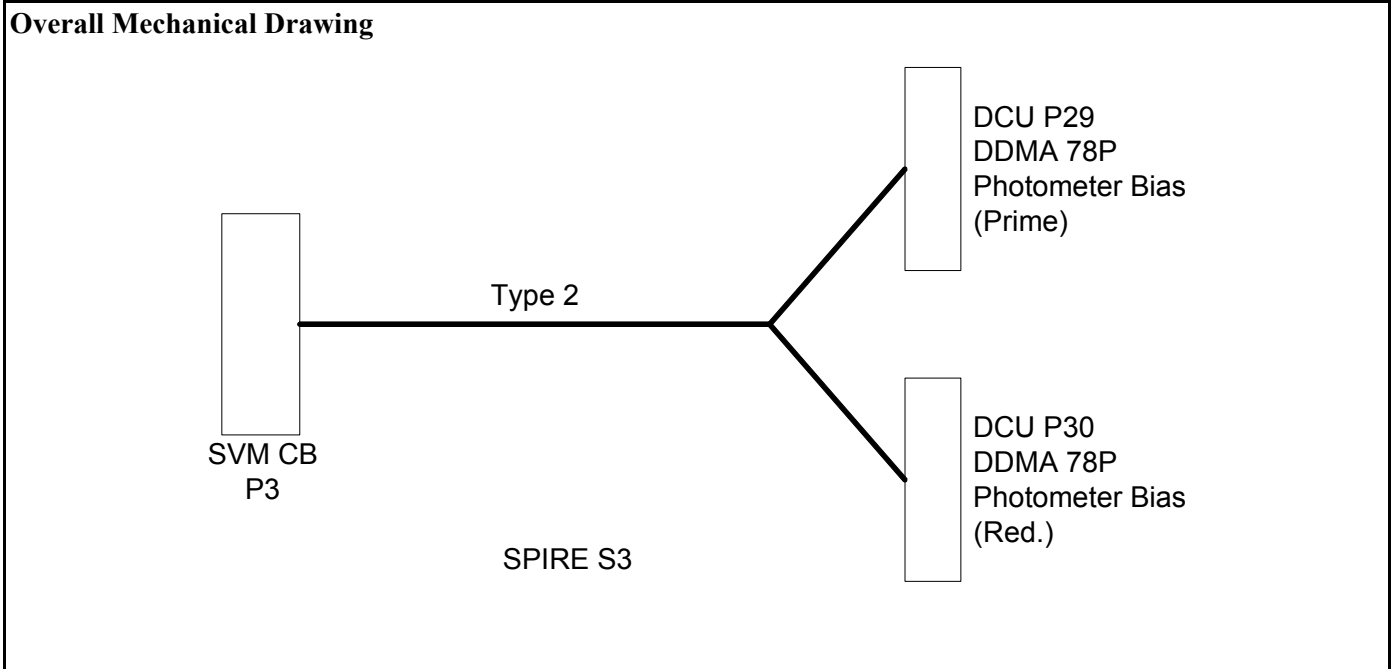

Connector/Backshell Details

DDMA78P+	Glenair	557-E-359-M-5-	TBD	to	DCUJ29	Phot Bias (Prime)
DDMA78P+	Glenair	557-E-359-M-5-	TBD	to	DCUJ30	Phot Bias (Red.)



SPIRE HARNESS DEFINITION DOCUMENT

Doc: SPIRE-RAL-PRJ-000608
 Issue: 1.2
 Date: 17/02/05
 Page 49 of 245

Harness Layup

Type 2 Bias Tails (DCU P29/P30)

- 25 Insulated STPs
- 4 Single insulated ground wires
- Note PSW, PMW and PLW Ground Separation
- See Section 4.2 for details regarding the implementation of the shields.
- No harness bundle overall insulation baselined. May be added later by locally wrapping with insulation at contact points.
- The Shields for the JFET Heaters are used to form the Faraday Shield Link. This is achieved by commoning the shields indicated by "B" at the 78-Way connector and connecting them to a lug on the backshell.
- A, B, C and D represent the commoning of functions within the connectors which pass through the 128-way CVV connector on single individual pins.
- The shields of the Heaters are connected to connector chassis which makes them functionally part of the FPU Faraday Shield link

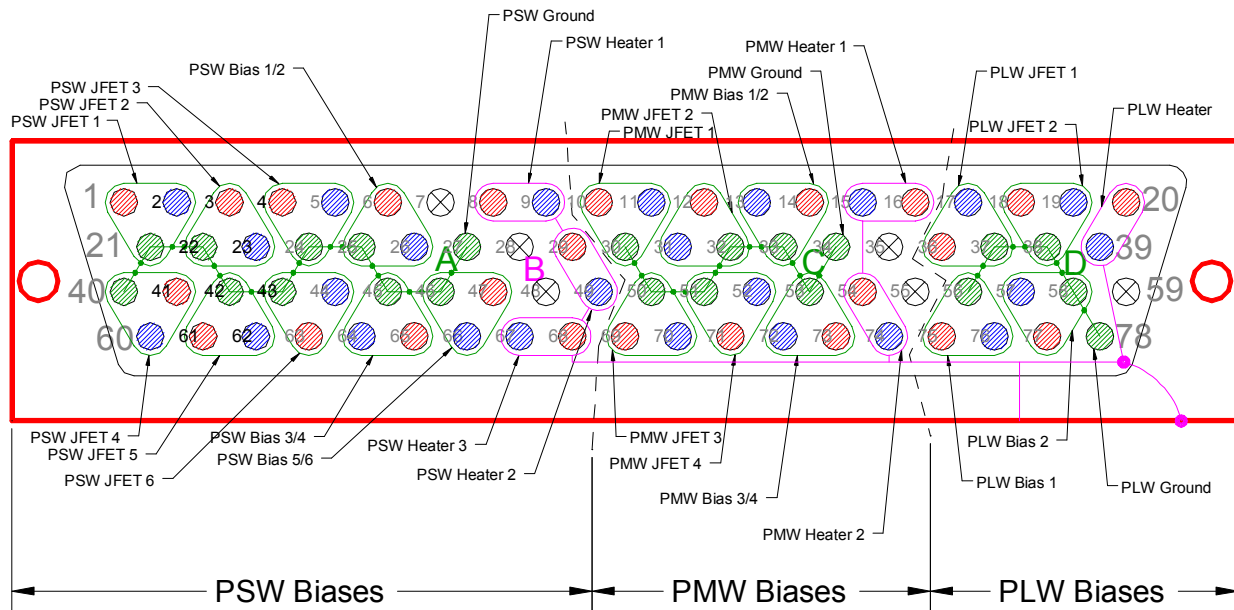



SPIRE HARNESS DEFINITION DOCUMENT

Doc: SPIRE-RAL-PRJ-000608

Issue: 1.2

Date: 17/02/05

Page 50 of 245

SVM-CB S3 128-Way Pin Allocations (View of wiring side of connector)

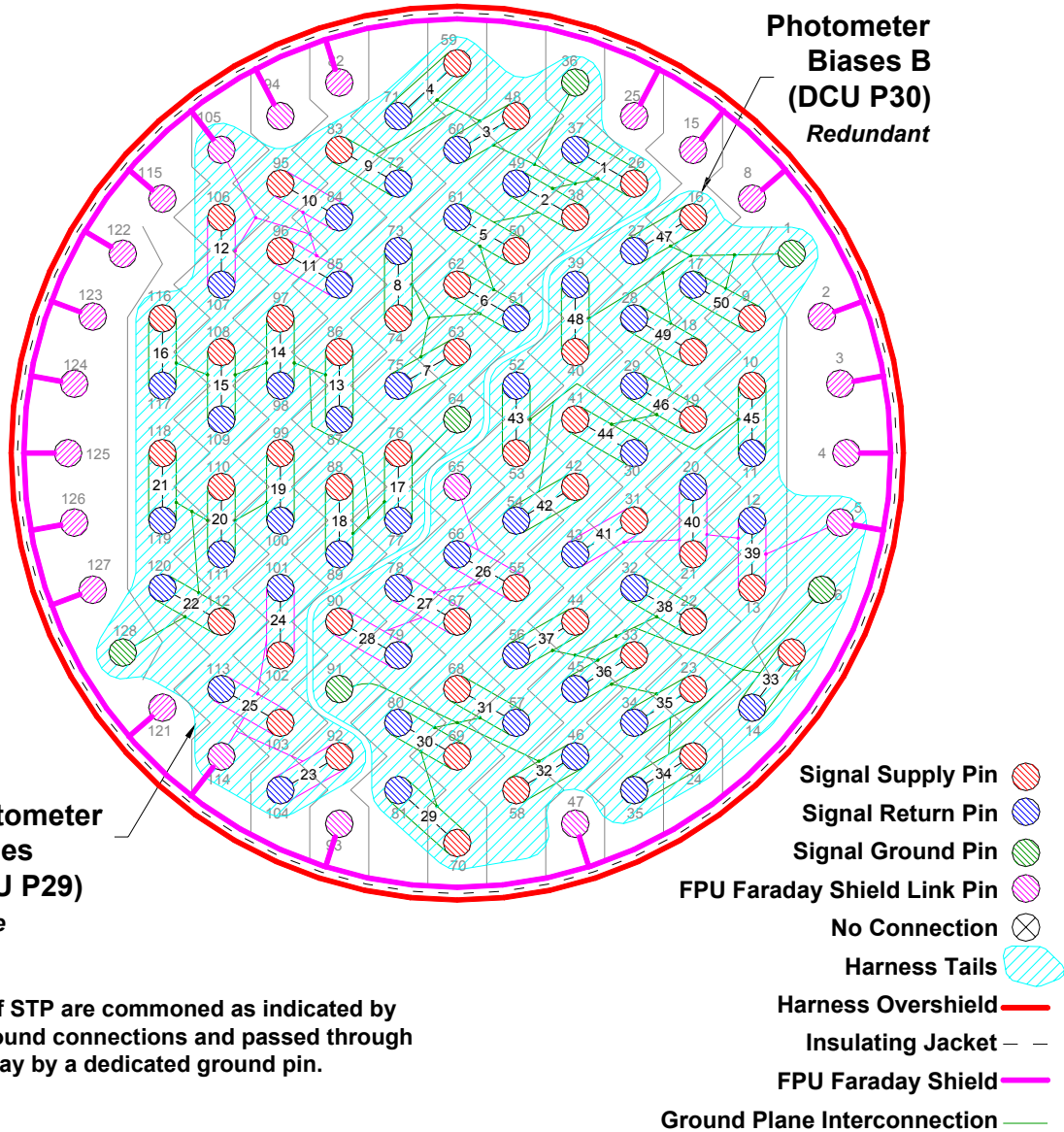



SPIRE HARNESS DEFINITION DOCUMENT

Doc: SPIRE-RAL-PRJ-000608

Issue: 1.2

Date: 17/02/05

Page 51 of 245

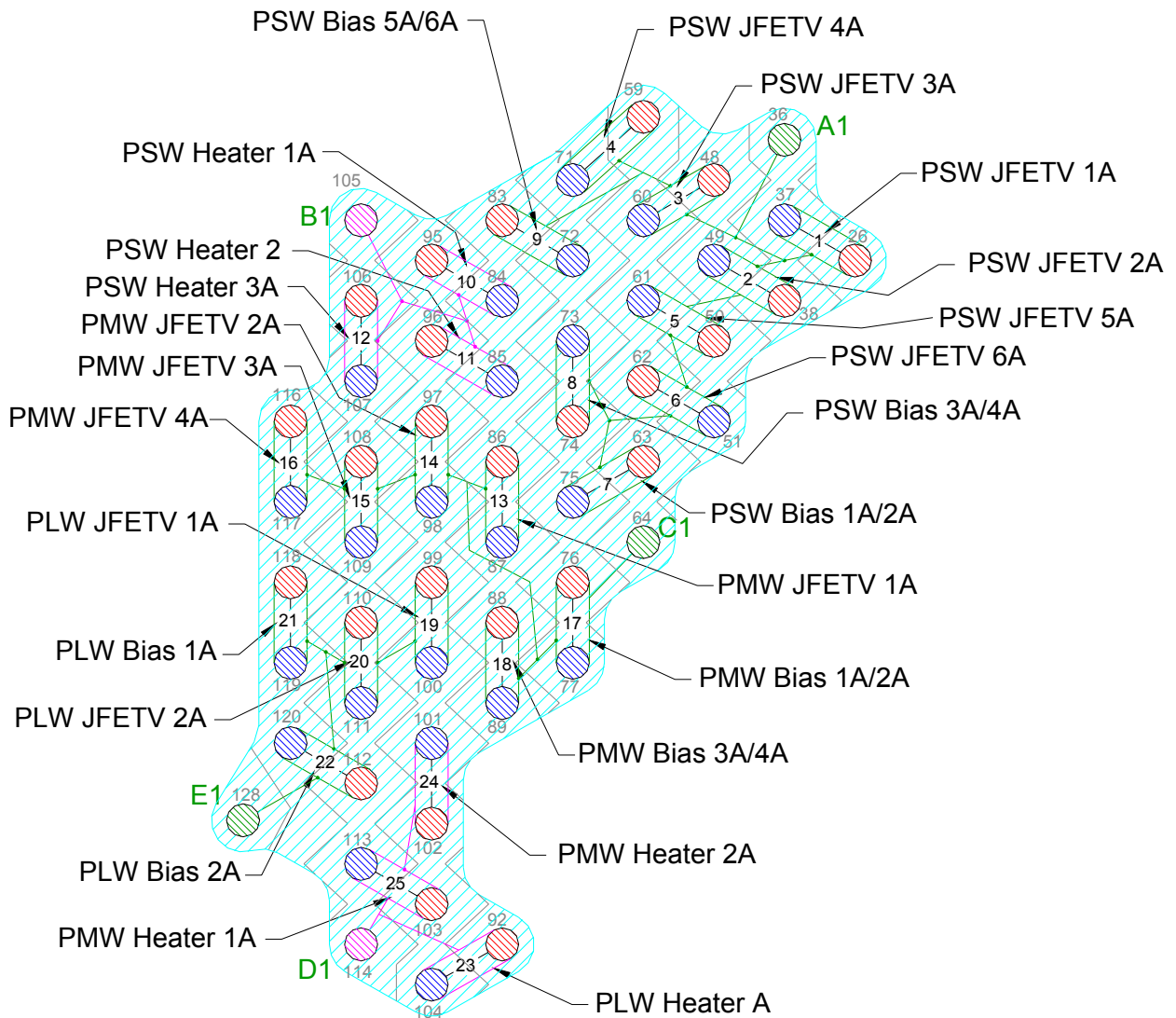

**Photometer Biases A (DCU P29)
Prime**



SPIRE HARNESS DEFINITION DOCUMENT

Doc: SPIRE-RAL-PRJ-000608

Issue: 1.2

Date: 17/02/05

Page 52 of 245

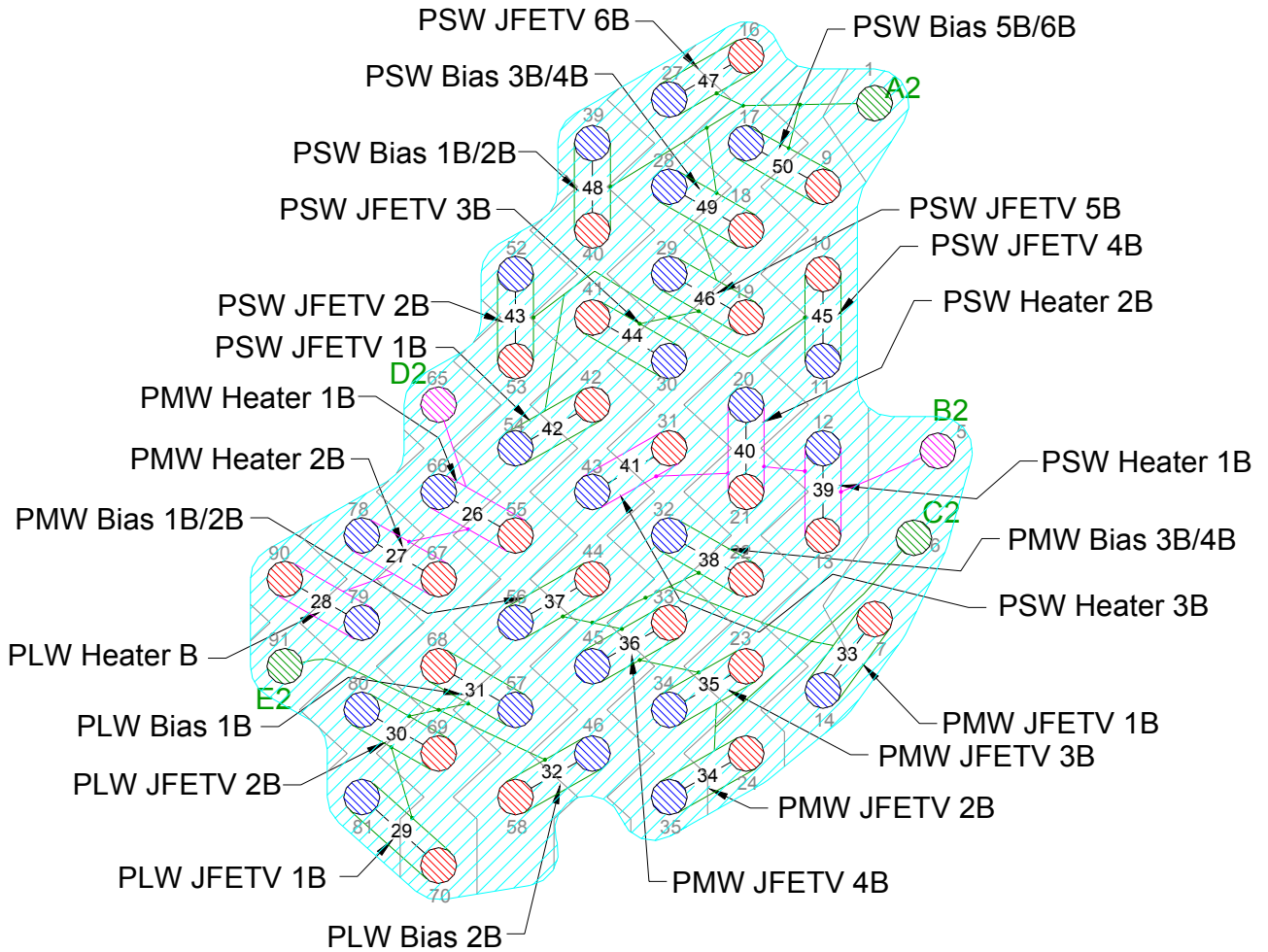

**Photometer Biases B (DCU P30)
Redundant**

Contact Details

Notes: Pin numbers on the 128-way suffixed by a letter in parentheses indicate the commoning of several ground reference wires or shields within the connector to a single pin on the 128-way CVV connector or the 37-way DCU connector.

Table 4.2-3 - SIH-SS-03 Listing

Description	Signal Name	128-Way #3	78-way Photometer Biases (J29)	78-way Photometer Biases (J30)
PSW JFETV1 A +	Vdd1 P	26	1	
PSW JFETV1 A -	Vss1 P	37	2	
PSW JFETV1 A shld	Gnd Bias Ph	36 (A1)	21 (A1)	
PSW JFETV2 A +	Vdd2 P	38	3	
PSW JFETV2 A -	Vss2 P	49	23	
PSW JFETV2 A shld	Gnd Bias Ph	36 (A1)	22 (A1)	
PSW JFETV3 A +	Vdd3 P	48	4	
PSW JFETV3 A -	Vss3 P	60	5	
PSW JFETV3 A shld	Gnd Bias Ph	36 (A1)	24 (A1)	
PSW JFETV4 A +	Vdd4 P	59	41	
PSW JFETV4 A -	Vss4 P	71	60	
PSW JFETV4 A shld	Gnd Bias Ph	36 (A1)	40 (A1)	
PSW JFETV5 A +	Vdd5 P	50	61	
PSW JFETV5 A -	Vss5 P	61	62	
PSW JFETV5 A shld	Gnd Bias Ph	36 (A1)	42 (A1)	
PSW JFETV6 A +	Vdd6 P	62	63	
PSW JFETV6 A -	Vss6 P	51	44	
PSW JFETV6 A shld	Gnd Bias Ph	36 (A1)	43 (A1)	
PSW GRND A	Gnd Bias Ph	36 (A1)	27 (A1)	
PSW BIAS1/2 A +	PBias P250	63	6	
PSW BIAS1/2 A -	Nbias 250	75	26	
PSW BIAS1/2 A shld	Gnd Bias Ph	36 (A1)	25 (A1)	
PSW BIAS3/4 A +	Pbias P250	74	65	
PSW BIAS3/4 A -	Nbias P250	73	64	
PSW BIAS3/4 A shld	Gnd Bias Ph	36 (A1)	45 (A1)	
PSW BIAS5/6 A +	Pbias P250	83	47	
PSW BIAS5/6 A -	Nbias P250	72	66	
PSW BIAS5/6 A shld	Gnd Bias Ph	36 (A1)	46 (A1)	
PSW HEATER A1 +	Pheater PSW1	95	8	
PSW HEATER A1 -	Nheater PSW1	84	9	
PSW HEATER A1 shld	Gnd Bias Ph	105 (B1)	Backshell	
PSW HEATER A2 +	Pheater PSW2	96	29	
PSW HEATER A2 -	Nheater PSW2	85	49	
PSW HEATER A2 shld	Gnd Bias Ph	105 (B1)	Backshell	
PSW HEATER A3 +	Pheater PSW3	106	68	
PSW HEATER A3 -	Nheater PSW3	107	67	
PSW HEATER A3 shld	Gnd Bias Ph	105 (B1)	Backshell	
PMW JFETV1 A +	Vdd7 P	86	10	
PMW JFETV1 A -	Vss7 P	87	11	
PMW JFETV1 A shld	Gnd Bias Ph	64 (C1)	30 (C1)	
PMW JFETV2 A +	Vdd8 P	97	12	
PMW JFETV2 A -	Vss8 P	98	31	
PMW JFETV2 A shld	Gnd Bias Ph	64 (C1)	32 (C1)	
PMW JFETV3 A +	Vdd9 P	108	69	
PMW JFETV3 A -	Vss9 P	109	70	
PMW JFETV3 A shld	Gnd Bias Ph	64 (C1)	50 (C1)	
PMW JFETV4 A +	Vdd10 P	116	71	
PMW JFETV4 A -	Vss10 P	117	52	
PMW JFETV4 A shld	Gnd Bias Ph	64 (C1)	51 (C1)	
PMW BIAS1/2 A +	PBias P350	76	14	
PMW BIAS1/2 A -	Nbias P350	77	13	
PMW BIAS1/2 A shld	Gnd Bias Ph	64 (C1)	33 (C1)	
PMW BIAS3/4 A +	Pbias P350	88	73	
PMW BIAS3/4 A -	Nbias P350	89	72	
PMW BIAS3/4 A shld	Gnd Bias Ph	64 (C1)	53 (C1)	
PMW GND WIRE A	Gnd Bias Ph	64 (C1)	34 (C1)	
PMW HEATER A1 +	Pheater PMW1	103	16	
PMW HEATER A1 -	Nheater PMW1	113	15	
PMW HEATER A1 shld	Gnd Bias Ph	114 (D1)	Backshell	



SPIRE HARNESS DEFINITION DOCUMENT

Doc: SPIRE-RAL-PRJ-000608
Issue: 1.2
Date: 17/02/05
Page 54 of 245

Description	Signal Name	128-Way #3	78-way Photometer Biases (J29)	78-way Photometer Biases (J30)
PMW HEATER A2 +	Pheater PMW2	102	54	
PMW HEATER A2 -	Nheater PMW2	101	74	
PMW HEATER A2 shld	Gnd Bias Ph	114 (D1)	Backshell	
PLW HEATER A +	Pheater PLW1	92	20	
PLW HEATER A -	Nheater PLW1	104	39	
PLW HEATER A shld	Gnd Bias Ph	114 (D1)	Backshell	
PLW JFETV1 A +	Vdd11 P	99	36	
PLW JFETV1 A -	Vss11 P	100	17	
PLW JFETV1 A shld	Gnd Bias Ph	128 (D1)	37 (D1)	
PLW JFETV2 A +	Vdd12 P	110	18	
PLW JFETV2 A -	Vss12 P	111	19	
PLW JFETV2 A shld	Gnd Bias Ph	128 (D1)	38 (D1)	
PLW BIAS1 A +	Pbias P500	118	75	
PLW BIAS1 A -	Nbias P500	119	76	
PLW BIAS1 A shld	Gnd Bias Ph	128 (D1)	56 (D1)	
PLW BIAS2 A +	Pbias P500	112	77	
PLW BIAS2 A -	Nbias P500	120	57	
PLW BIAS2 A shld	Gnd Bias Ph	128 (D1)	58 (D1)	
PLW GROUND WIRE A	Gnd Bias Ph	128 (D1)	78 (D1)	
PSW JFETV1 B +	Vdd1 P	42		1
PSW JFETV1 B -	Vss1 P	54		2
PSW JFETV1 B shld	Gnd Bias Ph	1 (A2)		21 (A2)
PSW JFETV2 B +	Vdd2 P	53		3
PSW JFETV2 B -	Vss2 P	52		23
PSW JFETV2 B shld	Gnd Bias Ph	1 (A2)		22 (A2)
PSW JFETV3 B +	Vdd3 P	41		4
PSW JFETV3 B -	Vss3 P	30		5
PSW JFETV3 B shld	Gnd Bias Ph	1 (A2)		24 (A2)
PSW JFETV4 B +	Vdd4 P	10		41
PSW JFETV4 B -	Vss4 P	11		60
PSW JFETV4 B shld	Gnd Bias Ph	1 (A2)		40 (A2)
PSW JFETV5 B +	Vdd5 P	19		61
PSW JFETV5 B -	Vss5 P	29		62
PSW JFETV5 B shld	Gnd Bias Ph	1 (A2)		42 (A2)
PSW JFETV6 B +	Vdd6 P	16		63
PSW JFETV6 B -	Vss6 P	27		44
PSW JFETV6 B shld	Gnd Bias Ph	1 (A2)		43 (A2)
PSW GRND B	Gnd Bias Ph	1 (A2)		27 (A2)
PSW BIAS1/2 B +	PBias P250	40		6
PSW BIAS1/2 B -	Nbias 250	39		26
PSW BIAS1/2 B shld	Gnd Bias Ph	1 (A2)		25 (A2)
PSW BIAS3/4 B +	Pbias P250	18		65
PSW BIAS3/4 B -	Nbias P250	28		64
PSW BIAS3/4 B shld	Gnd Bias Ph	1 (A2)		45 (A2)
PSW BIAS5/6 B +	Pbias P250	9		47
PSW BIAS5/6 B -	Nbias P250	17		66
PSW BIAS5/6 B shld	Gnd Bias Ph	1 (A2)		46 (A2)
PSW HEATER B1 +	Pheater PSW1	13		8
PSW HEATER B1 -	Nheater PSW1	12		9
PSW HEATER B1 shld	Gnd Bias Ph	5 (B2)		Backshell
PSW HEATER B2 +	Pheater PSW2	21		29
PSW HEATER B2 -	Nheater PSW2	20		49
PSW HEATER B2 shld	Gnd Bias Ph	5 (B2)		Backshell
PSW HEATER B3 +	Pheater PSW3	31		68
PSW HEATER B3 -	Nheater PSW3	43		67
PSW HEATER B3 shld	Gnd Bias Ph	5 (B2)		Backshell
PMW JFETV1 B +	Vdd7 P	7		10
PMW JFETV1 B -	Vss7 P	14		11
PMW JFETV1 B shld	Gnd Bias Ph	6 (C2)		30 (C2)
PMW JFETV2 B +	Vdd8 P	24		12
PMW JFETV2 B -	Vss8 P	35		31
PMW JFETV2 B shld	Gnd Bias Ph	6 (C2)		32 (C2)
PMW JFETV3 B +	Vdd9 P	23		69
PMW JFETV3 B -	Vss9 P	34		70
PMW JFETV3 B shld	Gnd Bias Ph	6 (C2)		50 (C2)
PMW JFETV4 B +	Vdd10 P	33		71
PMW JFETV4 B -	Vss10 P	45		52
PMW JFETV4 B shld	Gnd Bias Ph	6 (C2)		51 (C2)
PMW BIAS1/2 B +	PBias P350	44		14
PMW BIAS1/2 B -	Nbias P350	56		13



SPIRE HARNESS DEFINITION DOCUMENT

Doc: SPIRE-RAL-PRJ-000608
Issue: 1.2
Date: 17/02/05
Page 55 of 245

Description	Signal Name	128-Way #3	78-way Photometer Biases (J29)	78-way Photometer Biases (J30)
PMW BIAS1/2 B shld	Gnd Bias Ph	6 (C2)		33 (C2)
PMW BIAS3/4 B +	Pbias P350	22		73
PMW BIAS3/4 B -	Nbias P350	32		72
PMW BIAS3/4 B shld	Gnd Bias Ph	6 (C2)		53 (C2)
PMW GND WIRE B	Gnd Bias Ph	6 (C2)		34 (C2)
PMW HEATER B1 +	Pheater PMW1	55		16
PMW HEATER B1 -	Nheater PMW1	66		15
PMW HEATER B1 shld	Gnd Bias Ph	65 (D2)		Backshell
PMW HEATER B2 +	Pheater PMW2	67		54
PMW HEATER B2 -	Nheater PMW2	78		74
PMW HEATER B2 shld	Gnd Bias Ph	65 (D2)		Backshell
PLW HEATER B +	Pheater PLW1	90		20
PLW HEATER B -	Nheater PLW1	79		39
PLW HEATER B shld	Gnd Bias Ph	65 (F2)		Backshell
PLW JFETV1 B +	Vdd11_P	70		36
PLW JFETV1 B -	Vss11_P	81		17
PLW JFETV1 B shld	Gnd Bias Ph	91 (E2)		37 (E2)
PLW JFETV2 B +	Vdd12_P	69		18
PLW JFETV2 B -	Vss12_P	80		19
PLW JFETV2 B shld	Gnd Bias Ph	91 (E2)		38 (E2)
PLW BIAS1 B +	Pbias P500	68		75
PLW BIAS1 B -	Nbias P500	57		76
PLW BIAS1 B shld	Gnd Bias Ph	91 (E2)		56 (E2)
PLW BIAS2 B +	Pbias P500	58		77
PLW BIAS2 B -	Nbias P500	46		57
PLW BIAS2 B shld	Gnd Bias Ph	91 (E2)		58 (E2)
PLW GROUND WIRE B	Gnd Bias Ph	91 (E2)		78 (E2)
Harness Over-shield		EMC Backshell	EMC Backshell	EMC Backshell

FPU Faraday Shield Link Pins												
2	3	4	5	7	8	15	25	47	65	82	93	94
105	114	115	121	122	123	124	125	126	127	X	X	X



SPIRE HARNESS DEFINITION DOCUMENT

Doc: SPIRE-RAL-PRJ-000608
 Issue: 1.2
 Date: 17/02/05
 Page 56 of 245

4.2.4 S4 SVM-CB 4 – DRCU (Type 1) PMW

Overall Mechanical Drawing

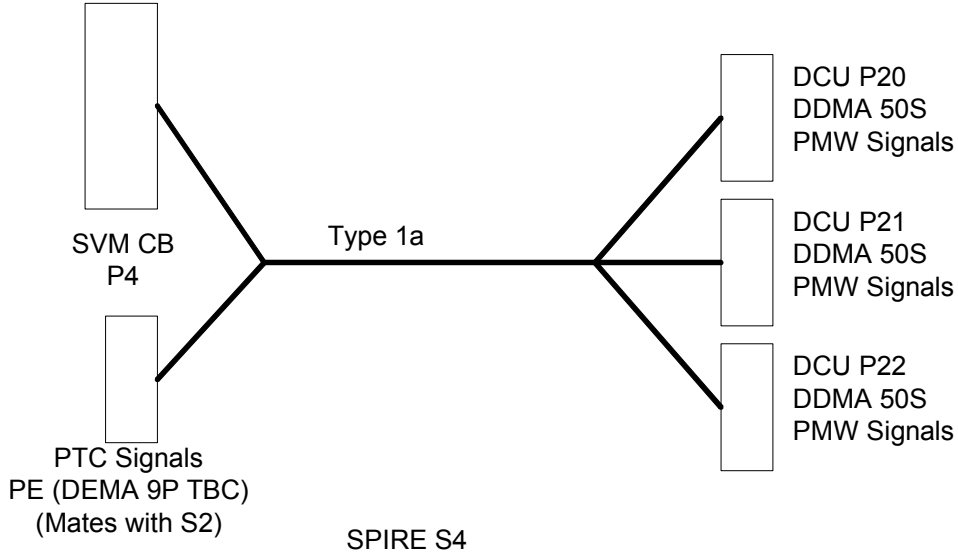

Connector/Backshell Details

DDMA50S+Glenair557-B-357-M-5 to	DCUJ20	DCU-JFP	(45° Entry Backshell)
DDMA50S+Glenair557-E-359-M-5 to	DCUJ21	DCU-JFP	(End Entry Backshell)
DDMA50S+Glenair557-B-357-M-5 to	DCUJ22	DCU-JFP	(45° Entry Backshell)
DEMA 9 P+Glenair557-?-?-M-1 to	DCUJ22	DCU-JFS via S2	

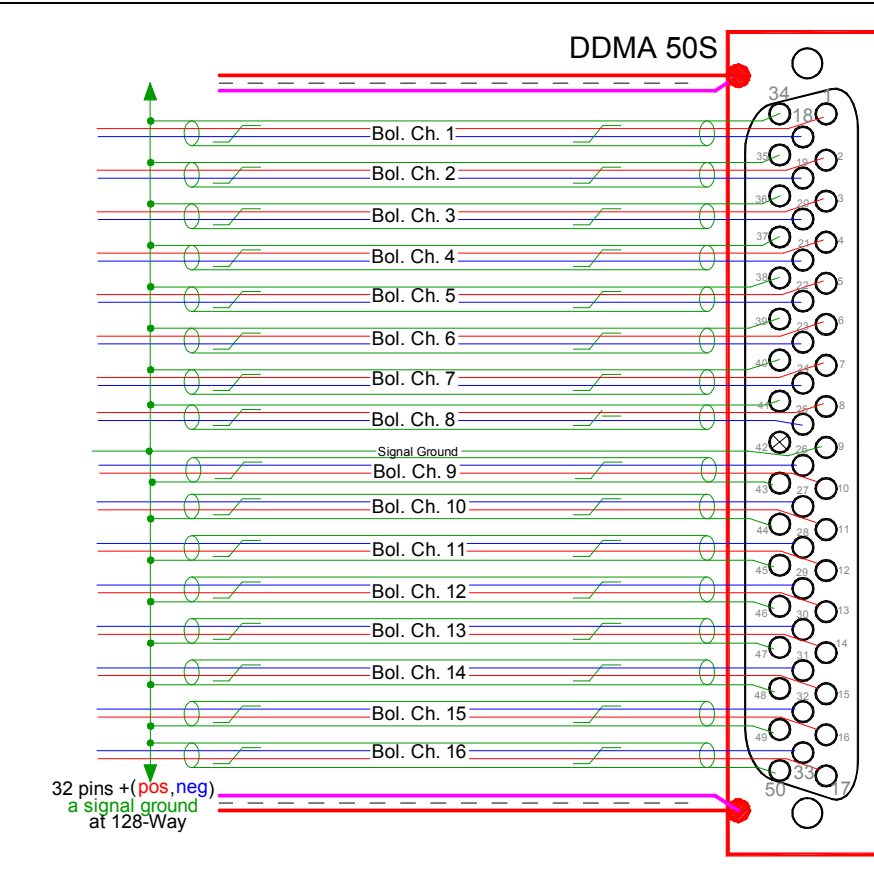

Type 1 DCU Tails

- This is the standard tail used for Photometer BDA readout (DCU P5 through to P21). Note that DCU P22 is different due to the incorporation of the PTC Signals
- 16 Insulated STPs
- 2 Single insulated ground wires
- See Section 4.2 for details regarding the implementation of the shields.
- No harness bundle overall insulation baselined. May be added later by locally wrapping with insulation at contact points.
- Harness connector is a Socket. Drawing indicates pin allocation as seen from the rear, non-engaging face of the connector.



SPIRE HARNESS DEFINITION DOCUMENT

Doc: SPIRE-RAL-PRJ-000608
 Issue: 1.2
 Date: 17/02/05
 Page 57 of 245

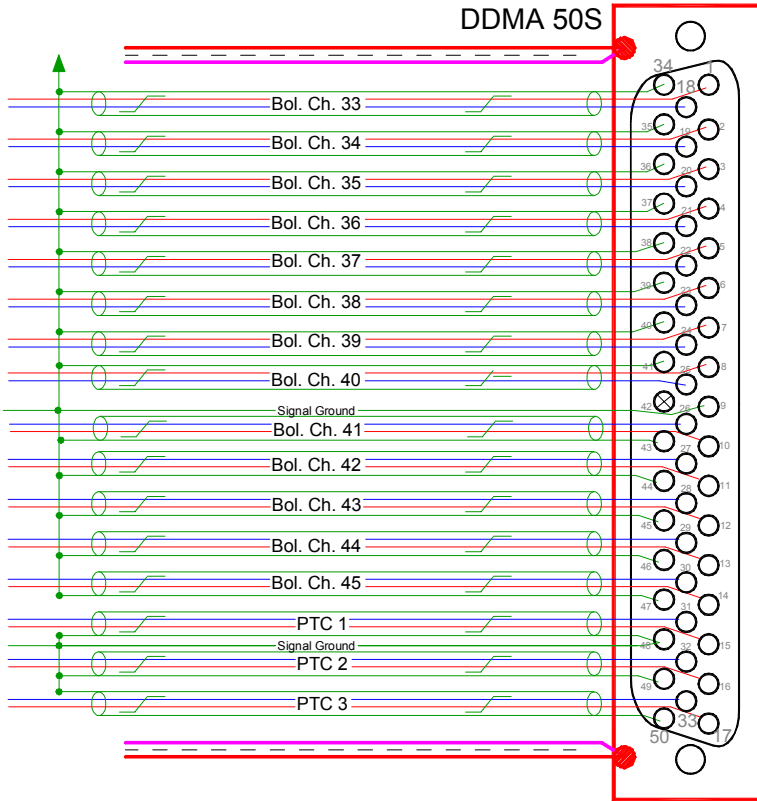

DCU P22 PMW and PTC Readout

- 16 Insulated STPs
- 3 Single insulated ground wires
- See Section 4.2 for details regarding the implementation of the shields.
- No harness bundle overall insulation baselined. May be added later by locally wrapping with insulation at contact points.
- Harness connector is a Socket. Drawing indicates pin allocation as seen from the rear, non-engaging face of the connector.

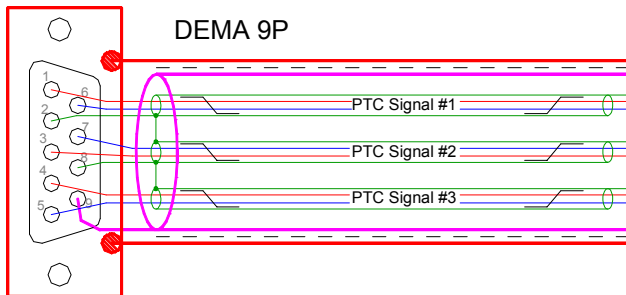

Photometer Thermal Control Signals (PE)

- 3 Insulated STPs
- See Section 4.2 for details regarding the implementation of the shields.
- No harness bundle overall insulation baselined. May be added later by locally wrapping with insulation at contact points.
- Harness connector is a Plug. Drawing indicates pin allocation as seen from the rear, non-engaging face of the connector.



SPIRE HARNESS DEFINITION DOCUMENT

Doc: SPIRE-RAL-PRJ-000608

Issue: 1.2

Date: 17/02/05

Page 58 of 245

SVM-CB S4 128-Way Pin Allocations (View of wiring side of connector)

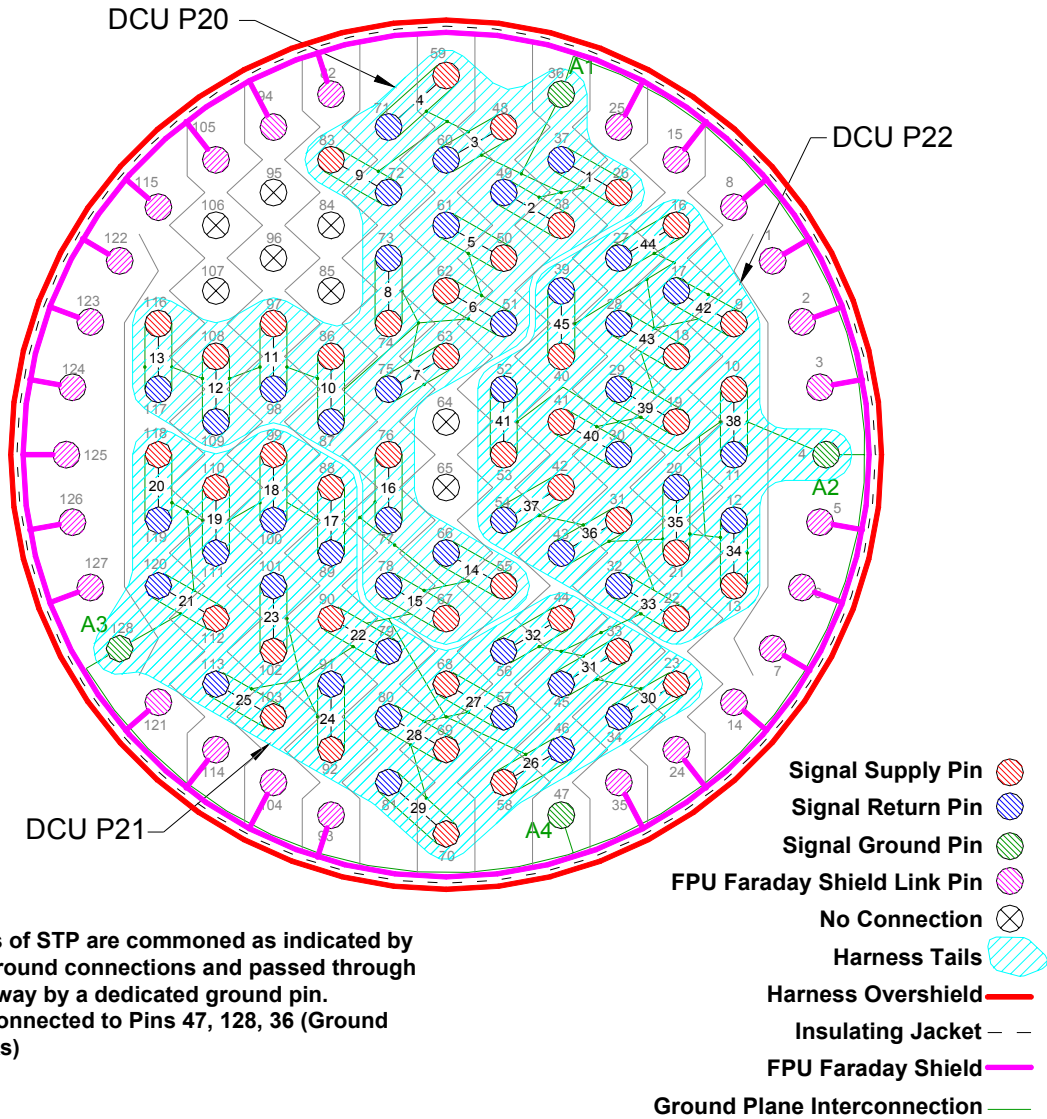



SPIRE HARNESS DEFINITION DOCUMENT

Doc: SPIRE-RAL-PRJ-000608

Issue: 1.2

Date: 17/02/05

Page 59 of 245

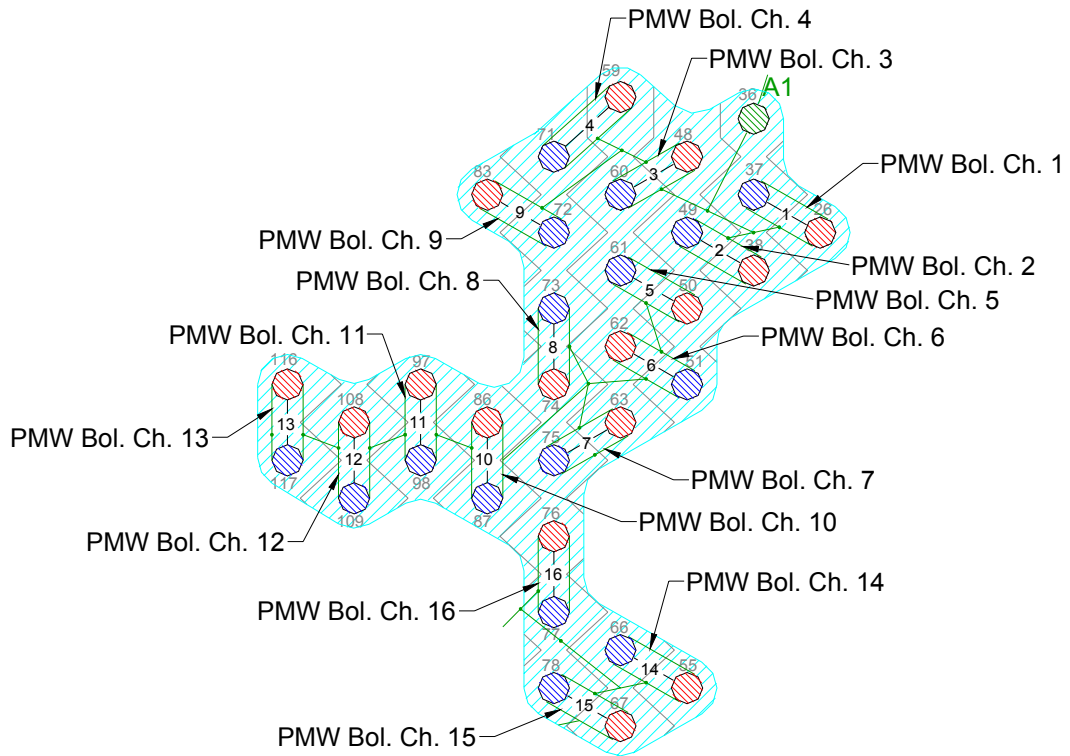

DCU P20

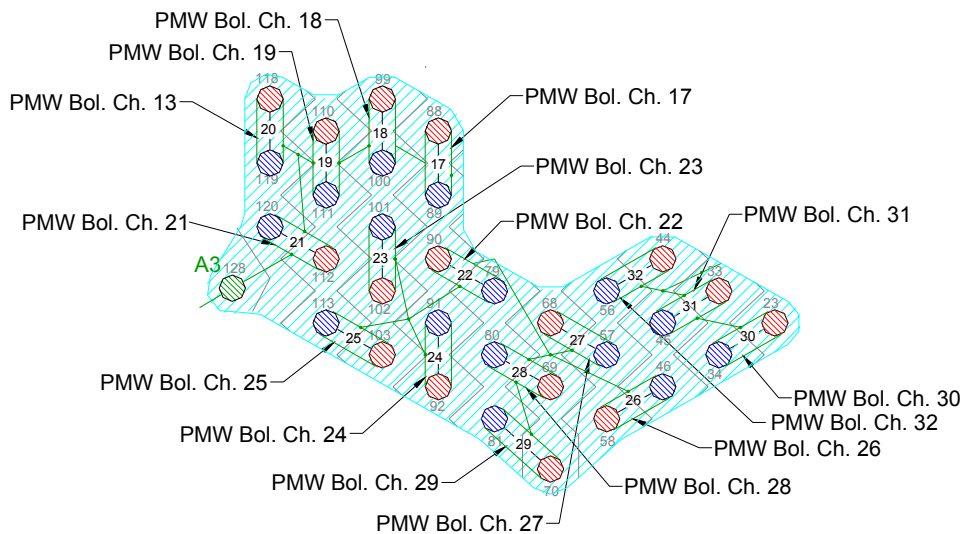

DCU P21



SPIRE HARNESS DEFINITION DOCUMENT

Doc: SPIRE-RAL-PRJ-000608
Issue: 1.2
Date: 17/02/05
Page 60 of 245

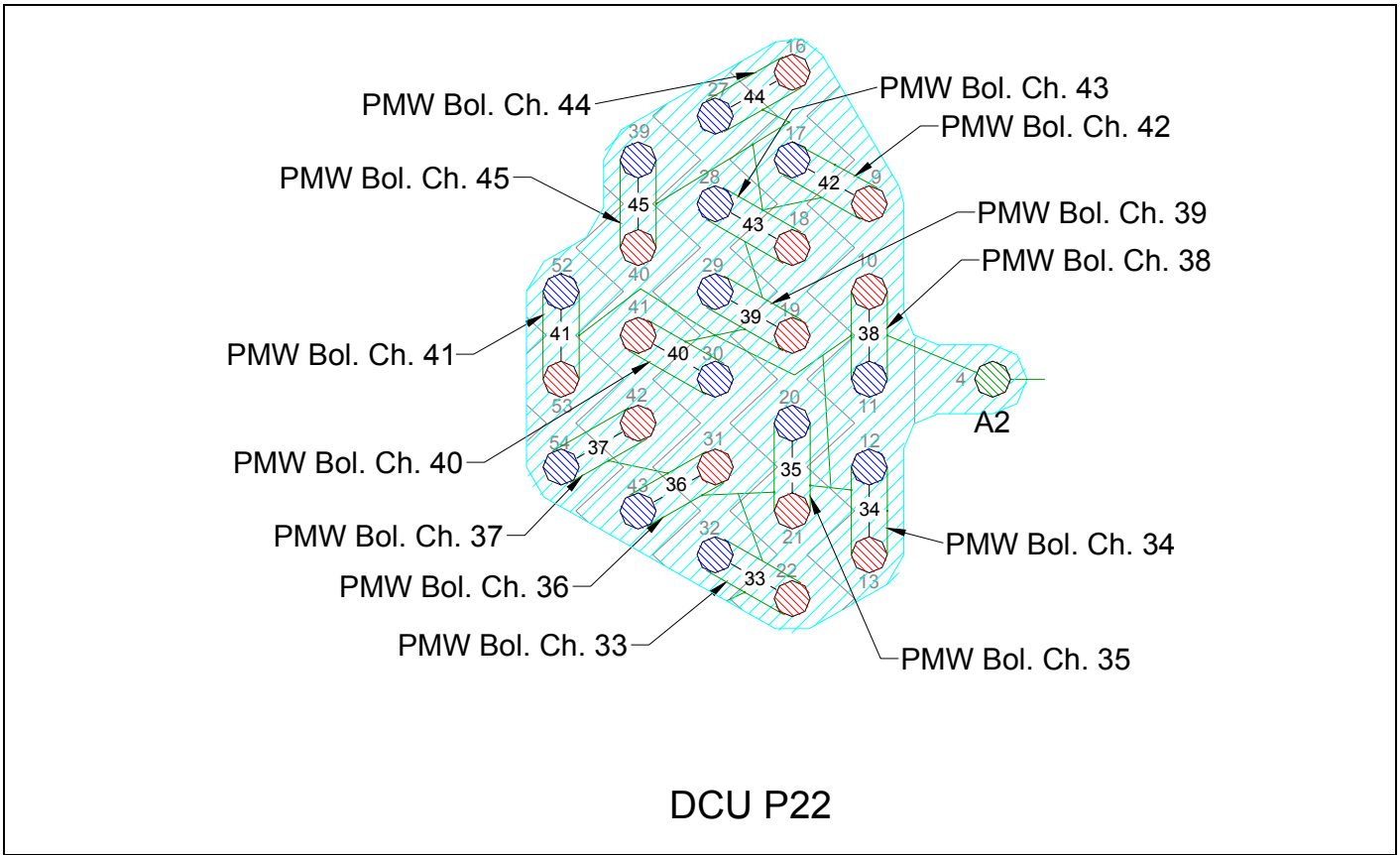

Contact Details

Notes:

- The shields of the STP cables carrying, the ground wires (GND_WIRE) and Pins 36(A1), 4(A2), 128(A3) and 47(A4) of the 128-way connector are all joined to form a ground reference plane. Pin numbers for connector PE assume the use of a DEMA 9 connector.
- Refer to Annex 7 - PTC Cryo-harnessing that indicates graphically the means by which these signals are wired.

Table 4.2-4 - SIH-SS-04 Listing

Cable ID	Pixel	128 Way #4	DCU P20	DCU P21	DCU P22	PE J22 Link (I/F S2/S4)
	Signal Ground	47 (A4)				
S4-STP-A1	Channel 1+	26	1			
	Channel 1-	37	18			
	Channel 1 GND	36 (A1)	34			
S4-STP-A2	Channel 2+	38	2			
	Channel 2-	49	19			
	Channel 2 GND	36 (A1)	35			
S4-STP-A3	Channel 3+	48	3			
	Channel 3-	60	20			
	Channel 3 GND	36 (A1)	36			
S4-STP-A4	Channel 4+	59	4			
	Channel 4-	71	21			
	Channel 4 GND	36 (A1)	37			
S4-STP-B1	Channel 5+	50	5			
	Channel 5-	61	22			
	Channel 5 GND	36 (A1)	38			
S4-STP-B2	Channel 6+	62	6			
	Channel 6-	51	23			
	Channel 6 GND	36 (A1)	39			
S4-STP-B3	Channel 7+	63	7			
	Channel 7-	75	24			
	Channel 7 GND	36 (A1)	40			
S4-STP-B4	Channel 8+	74	8			



SPIRE HARNESS DEFINITION DOCUMENT

Doc: SPIRE-RAL-PRJ-000608
Issue: 1.2
Date: 17/02/05
Page 61 of 245

Cable ID		Pixel	128 Way #4	DCU P20	DCU P21	DCU P22	PE J22 Link (I/F S2/S4)
	Channel 8-		73	25			
	Channel 8 GND		36 (A1)	41			
	Signal Ground		36 (A1)	9			
S4-STP-C1	Channel 9+	PMW-DK2	83	26			
	Channel 9-		72	10			
	Channel 9 GND		36 (A1)	43			
S4-STP-D1	Channel 13+	PMW-E7	86	27			
	Channel 13-		87	11			
	Channel 13 GND		36 (A1)	44			
S4-STP-D2	Channel 14+	PMW-D7	97	28			
	Channel 14-		98	12			
	Channel 14 GND		36 (A1)	45			
S4-STP-D3	Channel 15+	PMW-F7	108	29			
	Channel 15-		109	13			
	Channel 15 GND		36 (A1)	46			
S4-STP-D4	Channel 16+	PMW-E8	116	30			
	Channel 16-		117	14			
	Channel 16 GND		36 (A1)	47			
S4-STP-E1	Channel 17+	PMW-G8	55	31			
	Channel 17-		66	15			
	Channel 17 GND		128 (A3)	48			
S4-STP-E2	Channel 18+	PMW-F8	67	32			
	Channel 18-		78	16			
	Channel 18 GND		128 (A3)	49			
S4-STP-E3	Channel 19+	PMW-E9	76	33			
	Channel 19-		77	17			
	Channel 19 GND		128 (A3)	50			
S4-STP-E4	Channel 20+	PMW-G9	88		1		
	Channel 20-		89		18		
	Channel 20 GND		128 (A3)		34		
S4-STP-F1	Channel 21+	PMW-D9	99		2		
	Channel 21-		100		19		
	Channel 21 GND		128 (A3)		35		
S4-STP-F2	Channel 22+	PMW-F9	110		3		
	Channel 22-		111		20		
	Channel 22 GND		128 (A3)		36		
S4-STP-F3	Channel 23+	PMW-E10	118		4		
	Channel 23-		119		21		
	Channel 23 GND		128 (A3)		37		
S4-STP-F4	Channel 24+	PMW-G10	112		5		
	Channel 24-		120		22		
	Channel 24 GND		128 (A3)		38		
S4-STP-G1	Channel 25+	PMW-C4	90		6		
	Channel 25		79		23		
	Channel 25 GND		128 (A3)		39		
S4-STP-G2	Channel 26+	PMW-B3	102		7		
	Channel 26-		101		24		
	Channel 26 GND		128 (A3)		40		
S4-STP-G3	Channel 27+	PMW-C3	92		8		
	Channel 27-		91		25		
	Channel 27 GND		128 (A3)		41		
	Signal Ground		128 (A3)		9		
S4-STP-G4	Channel 28+	PMW-B2	103		26		
	Channel 28-		113		10		
	Channel 28 GND		128 (A3)		43		
S4-STP-H1	Channel 29+	PMW-D2	58		27		
	Channel 29-		46		11		
	Channel 29 GND		128 (A3)		44		
S4-STP-H2	Channel 30+	PMW-A3	68		28		
	Channel 30-		57		12		
	Channel 30 GND		128 (A3)		45		
S4-STP-H3	Channel 31+	PMW-A2	69		29		
	Channel 31-		80		13		
	Channel 31 GND		128 (A3)		46		
S4-STP-H4	Channel 32+	PMW-C2	70		30		
	Channel 32-		81		14		
	Channel 32 GND		128 (A3)		47		
S4-STP-I1	Channel 33+	PMW-B1	23		31		
	Channel 33-		34		15		



SPIRE HARNESS DEFINITION DOCUMENT

Doc: SPIRE-RAL-PRJ-000608
Issue: 1.2
Date: 17/02/05
Page 62 of 245

Cable ID		Pixel	128 Way #4	DCU P20	DCU P21	DCU P22	PE J22 Link (I/F S2/S4)
	Channel 33 GND		4 (A2)		48		
S4-STP-I2	Channel 34+	PMW-A1	33		32		
	Channel 34-		45		16		
	Channel 34 GND		4 (A2)		49		
S4-STP-I3	Channel 35+	PMW-DK1	44		33		
	Channel 35-		56		17		
	Channel 35 GND		4 (A2)		50		
S4-STP-I4	Channel 36+	PMW-C1	22			1	
	Channel 36-		32			18	
	Channel 36 GND		4 (A2)			34	
S4-STP-J1	Channel 37+	PMW-A7	13			2	
	Channel 37-		12			19	
	Channel 37 GND		4 (A2)			35	
S4-STP-J2	Channel 38+	PMW-A6	21			3	
	Channel 38-		20			20	
	Channel 38 GND		4 (A2)			36	
S4-STP-J3	Channel 39+	PMW-B6	31			4	
	Channel 39-		43			21	
	Channel 39 GND		4 (A2)			37	
S4-STP-J4	Channel 40+	PMW-C7	42			5	
	Channel 40-		54			22	
	Channel 40 GND		4 (A2)			38	
S4-STP-K1	Channel 41+	PMW-A5	10			6	
	Channel 41-		11			23	
	Channel 41 GND		4 (A2)			39	
S4-STP-K2	Channel 42+	PMW-B5	19			7	
	Channel 42-		29			24	
	Channel 42 GND		4 (A2)			40	
S4-STP-K3	Channel 43+	PMW-C6	41			8	
	Channel 43-		30			25	
	Channel 43 GND		4 (A2)			41	
	Signal Ground		4 (A2)			9	
S4-STP-K4	Channel 44+	PMW-D6	53			26	
	Channel 44-		52			10	
	Channel 44 GND		4 (A2)			43	
S4-STP-L1	Channel 45+	PMW-B4	9			27	
	Channel 45-		17			11	
	Channel 45 GND		4 (A2)			44	
S4-STP-L2	Channel 46+	PMW-C5	18			28	
	Channel 46-		28			12	
	Channel 46 GND		4 (A2)			45	
S4-STP-L3	Channel 47+	PMW-D4	16			29	
	Channel 47-		27			13	
	Channel 47 GND		4 (A2)			46	
S4-STP-L4	Channel 48+	PMW-A4	40			30	
	Channel 48-		39			14	
	Channel 48 GND		4 (A2)			47	
S4-STP-PTC1	PTC Channel 1 +	PTC-1	N.C.			31	1
	PTC Channel 1 -		N.C.			15	6
	PTC Channel 1gnd		N.C.			48	2 (A)
S4-STP-PTC2	PTC Channel 2 +	PTC-2	N.C.			32	3
	PTC Channel 2 -		N.C.			16	7
	PTC Channel 2gnd		N.C.			49	8(A)
S4-STP-PTC3	PTC Channel 3 +	PTC-3	N.C.			33	4
	PTC Channel 3 -		N.C.			17	5
	PTC Channel 3gnd		N.C.			50	8(A)
			EMC Backshell	EMC Backshell	EMC Backshell	EMC Backshell	EMC Backshell

FPU Faraday Shield Link Pins												
1	2	3	5	6	7	8	14	15	24	25	35	82
93	94	104	105	114	115	121	122	123	124	125	126	127

4.2.5 S5 SVM-CB 5 – DRCU (Type 1) PMW

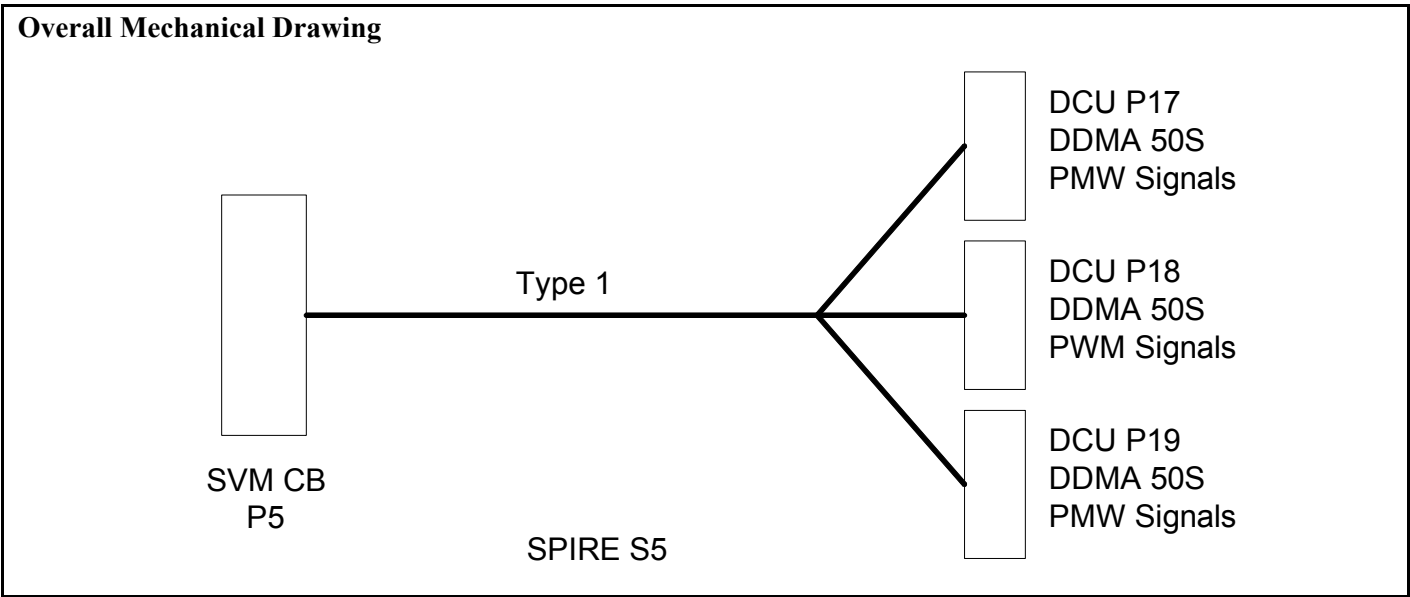

Connector/Backshell Details

DDMA50S+Glenair557-E-359-M-5	TBD	toDCUJ17	DCU-JFP
DDMA50S+Glenair557-B-357-M-5	TBD	toDCUJ18	DCU-JFP
DDMA50S+Glenair557-E-359-M-5	TBD	toDCUJ19	DCU-JFP



SPIRE HARNESS DEFINITION DOCUMENT

Doc: SPIRE-RAL-PRJ-000608

Issue: 1.2

Date: 17/02/05

Page 64 of 245

SVM-CB S5 128-Way Pin Allocations (View of wiring side of connector)

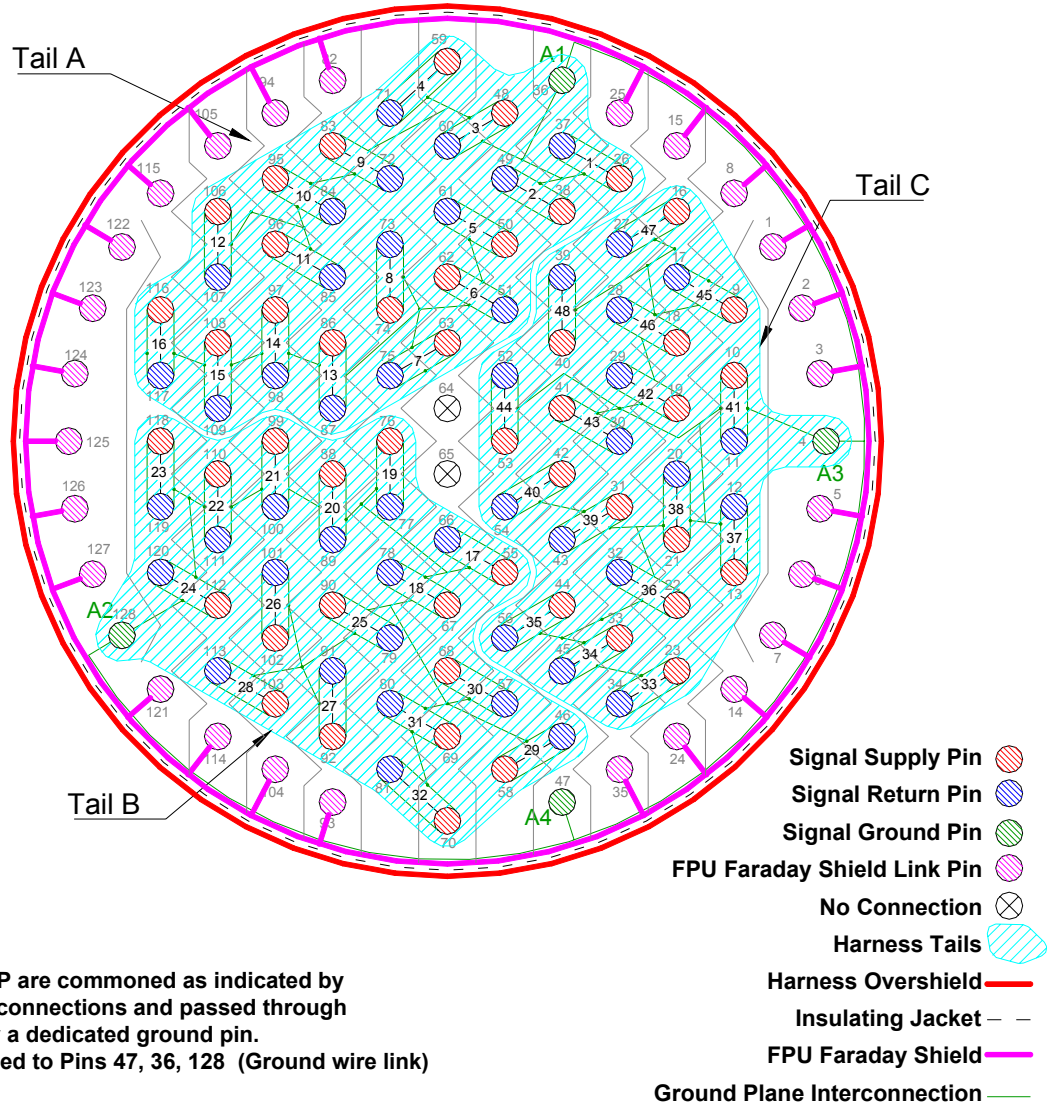

Tail A = HSDCU P17

Tail B = HSDCU P18

Tail C = HSDCU P19



SPIRE HARNESS DEFINITION DOCUMENT

Doc: SPIRE-RAL-PRJ-000608
Issue: 1.2
Date: 17/02/05
Page 65 of 245

Contact Details

Table 4.2-5 - SIH-SS-05 Listing

Wire Ident.	Name	Pixel	128Way #5	50way A DCU 17	50wayB DCU 18	50way C DCU 19
	Ground Pin		47 (A4)			
S5-STP-A1	Channel 1 +	PMW-A13	26	1		
	Channel 1 -		37	18		
	Channel 1gnd shld		36 (A1)	34		
S5-STP-A2	Channel 2 +	PMW-T1	38	2		
	Channel 2 -		49	19		
	Channel 2gnd shld		36 (A1)	35		
S5-STP-A3	Channel 3 +	PMW-B12	48	3		
	Channel 3 -		60	20		
	Channel 3gnd shld		36 (A1)	36		
S5-STP-A4	Channel 4 +	PMW-C13	59	4		
	Channel 4 -		71	21		
	Channel 4gnd shld		36 (A1)	37		
S5-STP-B1	Channel 5 +	PMW-A12	50	5		
	Channel 5 -		61	22		
	Channel 5gnd shld		36 (A1)	38		
S5-STP-B2	Channel 6 +	PMW-D12	62	6		
	Channel 6 -		51	23		
	Channel 6gnd shld		36 (A1)	39		
S5-STP-B3	Channel 7 +	PMW-C12	63	7		
	Channel 7 -		75	24		
	Channel 7gnd shld		36 (A1)	40		
S5-STP-B4	Channel 8 +	PMW-B11	74	8		
	Channel 8 -		73	25		
	Channel 8gnd shld		36 (A1)	41		
	GND WIRE		36 (A1)	9		
S5-STP-C1	Channel 9 +	PMW-A11	83	26		
	Channel 9 -		72	10		
	Channel 9gnd shld		36 (A1)	43		
S5-STP-C2	Channel 10 +	PMW-A13	95	27		
	Channel 10 -		84	11		
	Channel 10gnd shld		36 (A1)	44		
S5-STP-C3	Channel 11 +	PMW-D11	96	28		
	Channel 11 -		85	12		
	Channel 11gnd shld		36 (A1)	45		
S5-STP-C4	Channel 12 +	PMW-C11	106	29		
	Channel 12 -		107	13		
	Channel 12gnd shld		36 (A1)	46		
S5-STP-D1	Channel 13 +	PMW-B10	86	30		
	Channel 13 -		87	14		
	Channel 13gnd shld		36 (A1)	47		
S5-STP-D2	Channel 14 +	PMW-A10	97	31		
	Channel 14 -		98	15		
	Channel 14gnd shld		36 (A1)	48		
S5-STP-D3	Channel 15 +	PMW-D10	108	32		
	Channel 15 -		109	16		
	Channel 15gnd shld		36 (A1)	49		
S5-STP-D4	Channel 16 +	PMW-B9	116	33		
	Channel 16 -		117	17		
	Channel 16gnd shld		36 (A1)	50		
S5-STP-E1	Channel 17 +	PMW-C10	55		1	
	Channel 17 -		66		18	
	Channel 17gnd shld		128 (A2)		34	
S5-STP-E2	Channel 18 +	PMW-C9	67		2	
	Channel 18 -		78		19	
	Channel 18gnd shld		128 (A2)		35	
S5-STP-E3	Channel 19 +	PMW-A9	76		3	
	Channel 19 -		77		20	
	Channel 19gnd shld		128 (A2)		36	
S5-STP-E4	Channel 20 +	PMW-B8	88		4	
	Channel 20 -		89		21	
	Channel 20gnd shld		128 (A2)		37	
S5-STP-F1	Channel 21 +	PMW-A8	99		5	
	Channel 21 -		100		22	



SPIRE HARNESS DEFINITION DOCUMENT

Doc: SPIRE-RAL-PRJ-000608
Issue: 1.2
Date: 17/02/05
Page 66 of 245

Wire Ident.	Name	Pixel	128Way #5	50way A DCU 17	50wayB DCU 18	50way C DCU 19
	Channel 21gnd shld		128 (A2)		38	
S5-STP-F2	Channel 22 +	PMW-D8	110		6	
	Channel 22 -		111		23	
	Channel 22gnd shld		128 (A2)		39	
S5-STP-F3	Channel 23 +	PMW-C8	118		7	
	Channel 23 -		119		24	
	Channel 23gnd shld		128 (A2)		40	
S5-STP-F4	Channel 24 +	PMW-B7	112		8	
	Channel 24 -		120		25	
	Channel 24gnd shld		128 (A2)		41	
	GND WIRE		128 (A2)		9	
	FPU Faraday Shield Link		121		42	
S5-STP-G1	Channel 25 +	PMW-R1	90		26	
	Channel 25 -		79		10	
	Channel 25gnd shld		128 (A2)		43	
S5-STP-G2	Channel 26 +	PMW-G1	102		27	
	Channel 26 -		101		11	
	Channel 26gnd shld		128 (A2)		44	
S5-STP-G3	Channel 27 +	PMW-T2	92		28	
	Channel 27 -		91		12	
	Channel 27gnd shld		128 (A2)		45	
S5-STP-G4	Channel 28 +	PMW-E1	103		29	
	Channel 28 -		113		13	
	Channel 28gnd shld		128 (A2)		46	
S5-STP-H1	Channel 29 +	PMW-D1	58		30	
	Channel 29 -		46		14	
	Channel 29gnd shld		128 (A2)		47	
S5-STP-H2	Channel 30 +	PMW-F1	68		31	
	Channel 30 -		57		15	
	Channel 30gnd shld		128 (A2)		48	
S5-STP-H3	Channel 31 +	PMW-E2	69		32	
	Channel 31 -		80		16	
	Channel 31gnd shld		128 (A2)		49	
S5-STP-H4	Channel 32 +	PMW-G2	70		33	
	Channel 32 -		81		17	
	Channel 32gnd shld		128 (A2)		50	
S5-STP-I1	Channel 33 +	PMW-F2	23			1
	Channel 33 -		34			18
	Channel 33gnd shld		4 (A3)			34
S5-STP-I2	Channel 34 +	PMW-G3	33			2
	Channel 34 -		45			19
	Channel 34gnd shld		4 (A3)			35
S5-STP-I3	Channel 35 +	PMW-E3	44			3
	Channel 35 -		56			20
	Channel 35gnd shld		4 (A3)			36
S5-STP-I4	Channel 36 +	PMW-D3	22			4
	Channel 36 -		32			21
	Channel 36gnd shld		4 (A3)			37
S5-STP-J1	Channel 37 +	PMW-F3	13			5
	Channel 37 -		12			22
	Channel 37gnd shld		4 (A3)			38
S5-STP-J2	Channel 38 +	PMW-G4	21			6
	Channel 38 -		20			23
	Channel 38gnd shld		4 (A3)			39
S5-STP-J3	Channel 39 +	PMW-E4	31			7
	Channel 39 -		43			24
	Channel 39gnd shld		4 (A3)			40
S5-STP-J4	Channel 40 +	PMW-F4	42			8
	Channel 40 -		54			25
	Channel 40gnd shld		4 (A3)			41
	GND WIRE		4 (A3)			9
S5-STP-K1	Channel 41 +	PMW-E5	10			26
	Channel 41 -		11			10
	Channel 41gnd shld		4 (A3)			43
S5-STP-K2	Channel 42 +	PMW-D5	19			27
	Channel 42 -		29			11
	Channel 42gnd shld		4 (A3)			44
S5-STP-K3	Channel 43 +	PMW-F5	41			28
	Channel 43 -		30			12
	Channel 43gnd shld		4 (A3)			45



SPIRE HARNESS DEFINITION DOCUMENT

Doc: SPIRE-RAL-PRJ-000608
Issue: 1.2
Date: 17/02/05
Page 67 of 245

Wire Ident.	Name	Pixel	128Way #5	50way A DCU 17	50wayB DCU 18	50way C DCU 19
S5-STP-K4	Channel 44 +	PMW-G5	53			29
	Channel 44 -		52			13
	Channel 44gnd shld		4 (A3)			46
S5-STP-L1	Channel 45 +	PMW-E6	9			30
	Channel 45 -		17			14
	Channel 45gnd shld		4 (A3)			47
S5-STP-L2	Channel 46 +	PMW-G6	18			31
	Channel 46 -		28			15
	Channel 46gnd shld		4 (A3)			48
S5-STP-L3	Channel 47 +	PMW-F6	16			32
	Channel 47 -		27			16
	Channel 47gnd shld		4 (A3)			49
S5-STP-L4	Channel 48 +	PMW-G7	40			33
	Channel 48 -		39			17
	Channel 48gnd shld		4 (A3)			50
	Harness Overshield		EMC Backshell	EMC Backshell	EMC Backshell	EMC Backshell

FPU Faraday Shield Link Pins												
1	2	3	5	6	7	8	14	15	24	25	35	82
93	94	104	105	114	115	121	122	123	124	125	126	127



SPIRE HARNESS DEFINITION DOCUMENT

Doc: SPIRE-RAL-PRJ-000608
Issue: 1.2
Date: 17/02/05
Page 68 of 245

4.2.6 S6 SVM-CB 6 – DRCU (Type 1) PLW

Overall Mechanical Drawing

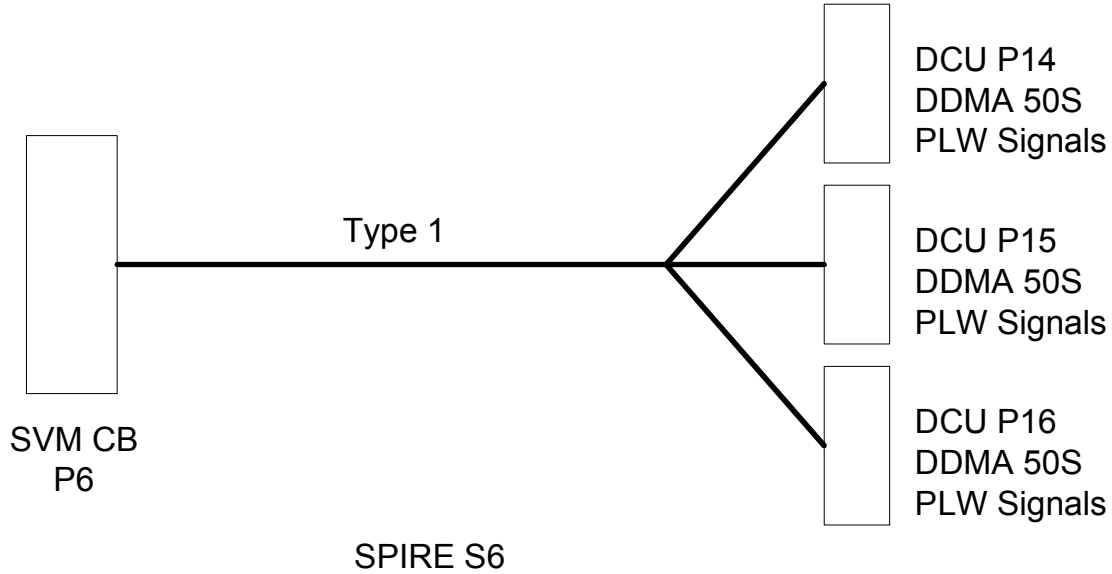

Connector/Backshell Details

DDMA50S+Glenair557-B-357-M-5- TBD toDCUJ14 DCU-JFP
DDMA50S+Glenair557-E-359-M-5- TBD toDCUJ15 DCU-JFP
DDMA50S+Glenair557-B-357-M-5- TBD toDCUJ16 DCU-JFP

Harness Layup

As S5 except
Tail A = HSDCU P14
Tail B = HSDCU P15
Tail C = HSDCU P16

Contact details

Table 4.2-6 - SIH-SS-06 Listing

Cable ID	Name	Pixel	128Way #6	DCU J14	DCU J15	DCU J16
	Ground Pin		47 (A4)			
S6-STP-A1	Channel 1 +	PLW-R1	26	1		
	Channel 1 -		37	18		
	Channel 1gnd shld		36 (A1)	34		
S6-STP-A2	Channel 2 +	PLW-A8	38	2		
	Channel 2 -		49	19		
	Channel 2gnd shld		36 (A1)	35		
S6-STP-A3	Channel 3 +	PLW-A7	48	3		
	Channel 3 -		60	20		
	Channel 3gnd shld		36 (A1)	36		
S6-STP-A4	Channel 4 +	PLW-A6	59	4		
	Channel 4 -		71	21		
	Channel 4gnd shld		36 (A1)	37		
S6-STP-B1	Channel 5 +	PLW-A9	50	5		
	Channel 5 -		61	22		
	Channel 5gnd shld		36 (A1)	38		
S6-STP-B2	Channel 6 +	PLW-C9	62	6		



SPIRE HARNESS DEFINITION DOCUMENT

Doc: SPIRE-RAL-PRJ-000608
Issue: 1.2
Date: 17/02/05
Page 69 of 245

Cable ID	Name	Pixel	128Way #6	DCU J14	DCU J15	DCU J16
	Channel 6 -		51	23		
	Channel 6gnd shld		36 (A1)	39		
	Channel 7 +		63	7		
S6-STP-B3	Channel 7 -	PLW-B8	75	24		
	Channel 7gnd shld		36 (A1)	40		
	Channel 8 +		74	8		
S6-STP-B4	Channel 8 -	PLW-B7	73	25		
	Channel 8gnd shld		36 (A1)	41		
	GND WIRE		36 (A1)	9		
S6-STP-C1	Channel 9 +	PLW-C7	83	26		
	Channel 9 -		72	10		
	Channel 9gnd shld		36 (A1)	43		
S6-STP-C2	Channel 10 +	PLW-B5	95	27		
	Channel 10 -		84	11		
	Channel 10gnd shld		36 (A1)	44		
S6-STP-C3	Channel 11 +	PLW-B6	96	28		
	Channel 11 -		85	12		
	Channel 11gnd shld		36 (A1)	45		
S6-STP-C4	Channel 12 +	PLW-A5	106	29		
	Channel 12 -		107	13		
	Channel 12gnd shld		36 (A1)	46		
S6-STP-D1	Channel 13 +	PLW-T1	86	30		
	Channel 13 -		87	14		
	Channel 13gnd shld		36 (A1)	47		
S6-STP-D2	Channel 14 +	PLW-B4	97	31		
	Channel 14 -		98	15		
	Channel 14gnd shld		36 (A1)	48		
S6-STP-D3	Channel 15 +	PLW-C4	108	32		
	Channel 15 -		109	16		
	Channel 15gnd shld		36 (A1)	49		
S6-STP-D4	Channel 16 +	PLW-B3	116	33		
	Channel 16 -		117	17		
	Channel 16gnd shld		36 (A1)	50		
S6-STP-E1	Channel 17 +	PLW-C2	55		1	
	Channel 17 -		66		18	
	Channel 17gnd shld		128 (A2)		34	
S6-STP-E2	Channel 18 +	PLW-B2	67		2	
	Channel 18 -		78		19	
	Channel 18gnd shld		128 (A2)		35	
S6-STP-E3	Channel 19 +	PLW-B1	76		3	
	Channel 19 -		77		20	
	Channel 19gnd shld		128 (A2)		36	
S6-STP-E4	Channel 20 +	PLW-A3	88		4	
	Channel 20 -		89		21	
	Channel 20gnd shld		128 (A2)		37	
S6-STP-F1	Channel 21 +	PLW-A4	99		5	
	Channel 21 -		100		22	
	Channel 21gnd shld		128 (A2)		38	
S6-STP-F2	Channel 22 +	PLW-A1	110		6	
	Channel 22 -		111		23	
	Channel 22gnd shld		128 (A2)		39	
S6-STP-F3	Channel 23 +	PLW-DK1	118		7	
	Channel 23 -		119		24	
	Channel 23gnd shld		128 (A2)		40	
S6-STP-F4	Channel 24 +	PLW-A2	112		8	
	Channel 24 -		120		25	
	Channel 24gnd shld		128 (A2)		41	
S6-STP-G1	GND WIRE		128 (A2)	9		
	Channel 25 +	PLW-E1	90		26	
	Channel 25 -		79		10	
Channel 25gnd shld	128 (A2)			43		
S6-STP-G2	Channel 26 +	PLW-E2	102		27	
	Channel 26 -		101		11	
	Channel 26gnd shld		128 (A2)		44	
S6-STP-G3	Channel 27 +	PLW-E3	92		28	
	Channel 27 -		91		12	
	Channel 27gnd shld		128 (A2)		45	
S6-STP-G4	Channel 28 +	PLW-E4	103		29	
	Channel 28 -		113		13	
	Channel 28gnd shld		128 (A2)		46	
S6-STP-H1	Channel 29 +	PLW-D1	58		30	



SPIRE HARNESS DEFINITION DOCUMENT

Doc: SPIRE-RAL-PRJ-000608
Issue: 1.2
Date: 17/02/05
Page 70 of 245

Cable ID	Name	Pixel	128Way #6	DCU J14	DCU J15	DCU J16
	Channel 29 -		46		14	
	Channel 29gnd shld		128 (A2)		47	
S6-STP-H2	Channel 30 +	PLW-D2	68		31	
	Channel 30 -		57		15	
	Channel 30gnd shld		128 (A2)		48	
S6-STP-H3	Channel 31 +	PLW-D3	69		32	
	Channel 31 -		80		16	
	Channel 31gnd shld		128 (A2)		49	
S6-STP-H4	Channel 32 +	PLW-D4	70		33	
	Channel 32 -		81		17	
	Channel 32gnd shld		128 (A2)		50	
S6-STP-I1	Channel 33 +	PLW-C1	23			1
	Channel 33 -		34			18
	Channel 33gnd shld		4 (A3)			34
S6-STP-I2	Channel 34 +	PLW-C3	33			2
	Channel 34 -		45			19
	Channel 34gnd shld		4 (A3)			35
S6-STP-I3	Channel 35 +	PLW-C5	44			3
	Channel 35 -		56			20
	Channel 35gnd shld		4 (A3)			36
S6-STP-I4	Channel 36 +	PLW-T2	22			4
	Channel 36 -		32			21
	Channel 36gnd shld		4 (A3)			37
S6-STP-J1	Channel 37 +	PLW-E5	13			5
	Channel 37 -		12			22
	Channel 37gnd shld		4 (A3)			38
S6-STP-J2	Channel 38 +	PLW-C6	21			6
	Channel 38 -		20			23
	Channel 38gnd shld		4 (A3)			39
S6-STP-J3	Channel 39 +	PLW-C8	31			7
	Channel 39 -		43			24
	Channel 39gnd shld		4 (A3)			40
S6-STP-J4	Channel 40 +	PLW-D5	42			8
	Channel 40 -		54			25
	Channel 40gnd shld		4 (A3)			41
	GND WIRE		4 (A3)			9
S6-STP-K1	Channel 41 +	PLW-D6	10			26
	Channel 41 -		11			10
	Channel 41gnd shld		4 (A3)			43
S6-STP-K2	Channel 42 +	PLW-D7	19			27
	Channel 42 -		29			11
	Channel 42gnd shld		4 (A3)			44
S6-STP-K3	Channel 43 +	PLW-D8	41			28
	Channel 43 -		30			12
	Channel 43gnd shld		4 (A3)			45
S6-STP-K4	Channel 44 +	PLW-E7	53			29
	Channel 44 -		52			13
	Channel 44gnd shld		4 (A3)			46
S6-STP-L1	Channel 45 +	PLW-E6	9			30
	Channel 45 -		17			14
	Channel 45gnd shld		4 (A3)			47
S6-STP-L2	Channel 46 +	PLW-E8	18			31
	Channel 46 -		28			15
	Channel 46gnd shld		4 (A3)			48
S6-STP-L3	Channel 47 +	PLW-DK2	16			32
	Channel 47 -		27			16
	Channel 47gnd shld		4 (A3)			49
S6-STP-L4	Channel 48 +	PLW-E9	40			33
	Channel 48 -		39			17
	Channel 48gnd shld		4 (A3)			50
	Harness Overshield		EMC Backshell	EMC Backshell	EMC Backshell	EMC Backshell

FPU Faraday Shield Link Pins												
1	2	3	5	6	7	8	14	15	24	25	35	82
93	94	104	105	114	115	121	122	123	124	125	126	127



SPIRE HARNESS DEFINITION DOCUMENT

Doc: SPIRE-RAL-PRJ-000608
Issue: 1.2
Date: 17/02/05
Page 71 of 245

4.2.7 S7 SVM-CB 7 – DRCU (Type 1) PSW

Overall Mechanical Drawing

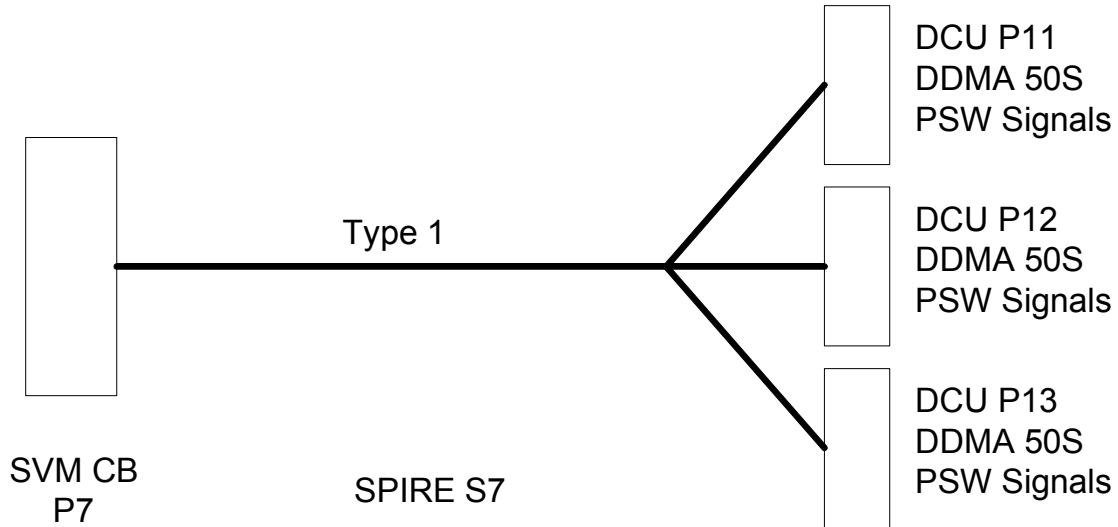

Connector/Backshell Details

DDMA50S	+	Glenair 557 - E-359-M-5toDCUJ11	DCU-JFP
DDMA50S	+	Glenair 557 - B-357-M-5toDCUJ12	DCU-JFP
DDMA50S	+	Glenair 557 - E-359-M-5toDCUJ13	DCU-JFP

Harness Layup

As S5 except
Tail A = HSDCU P11
Tail B = HSDCU P12
Tail C = HSDCU P13

Table 4.2-7 - SIH-SS-07 Listing

	Name		128Way #7	DCU P11	DCU P12	DCU P13
	Ground Pin		47 (A4)			
S7-STP-A1	Channel 1 +	PSW-D11	26	1		
	Channel 1 -		37	18		
	Channel 1gnd shld		36 (A1)	34		
S7-STP-A2	Channel 2 +	PSW-A10	38	2		
	Channel 2 -		49	19		
	Channel 2gnd shld		36 (A1)	35		
S7-STP-A3	Channel 3 +	PSW-E10	48	3		
	Channel 3 -		60	20		
	Channel 3gnd shld		36 (A1)	36		
S7-12-ax-A4	Channel 4 +	PSW-C10	59	4		
	Channel 4 -		71	21		
	Channel 4gnd shld		36 (A1)	37		
S7-STP-B1	Channel 5 +	PSW-B10	50	5		
	Channel 5 -		61	22		
	Channel 5gnd shld		36 (A1)	38		
S7-STP-B2	Channel 6 +	PSW-D10	62	6		
	Channel 6 -		51	23		



SPIRE HARNESS DEFINITION DOCUMENT

Doc: SPIRE-RAL-PRJ-000608
Issue: 1.2
Date: 17/02/05
Page 72 of 245

	Name		128Way #7	DCU P11	DCU P12	DCU P13
	Channel 6gnd shld		36 (A1)	39		
S7-STP-B3	Channel 7 +	PSW-A9	63	7		
	Channel 7 -		75	24		
	Channel 7gnd shld		36 (A1)	40		
S7-STP-B4	Channel 8 +	PSW-E9	74	8		
	Channel 8 -		73	25		
	Channel 8gnd shld		36 (A1)	41		
	GND WIRE		36 (A1)	9		
S7-STP-C1	Channel 9 +	PSW-C9	83	26		
	Channel 9 -		72	10		
	Channel 9gnd shld		36 (A1)	43		
S7-STP-C2	Channel 10 +	PSW-B9	95	27		
	Channel 10 -		84	11		
	Channel 10gnd shld		36 (A1)	44		
S7-STP-C3	Channel 11 +	PSW-D9	96	28		
	Channel 11 -		85	12		
	Channel 11gnd shld		36 (A1)	45		
S7-STP-C4	Channel 12 +	PSW-A8	106	29		
	Channel 12 -		107	13		
	Channel 12gnd shld		36 (A1)	46		
S7-STP-D1	Channel 13 +	PSW-C8	86	30		
	Channel 13 -		87	14		
	Channel 13gnd shld		36 (A1)	47		
S7-STP-D2	Channel 14 +	PSW-E8	97	31		
	Channel 14 -		98	15		
	Channel 14gnd shld		36 (A1)	48		
S7-STP-D3	Channel 15 +	PSW-D8	108	32		
	Channel 15 -		109	16		
	Channel 15gnd shld		36 (A1)	49		
S7-STP-D4	Channel 16 +	PSW-B8	116	33		
	Channel 16 -		117	17		
	Channel 16gnd shld		36 (A1)	50		
S7-STP-E1	Channel 17 +	PSW-C7	55		1	
	Channel 17 -		66		18	
	Channel 17gnd shld		128 (A2)		34	
S7-STP-E2	Channel 18 +	PSW-E7	67		2	
	Channel 18 -		78		19	
	Channel 18gnd shld		128 (A2)		35	
S7-STP-E3	Channel 19 +	PSW-A7	76		3	
	Channel 19 -		77		20	
	Channel 19gnd shld		128 (A2)		36	
S7-STP-E4	Channel 20 +	PSW-D7	88		4	
	Channel 20 -		89		21	
	Channel 20gnd shld		128 (A2)		37	
S7-STP-F1	Channel 21 +	PSW-B7	99		5	
	Channel 21 -		100		22	
	Channel 21gnd shld		128 (A2)		38	
S7-STP-F2	Channel 22 +	PSW-C6	110		6	
	Channel 22 -		111		23	
	Channel 22gnd shld		128 (A2)		39	
S7-STP-F3	Channel 23 +	PSW-E6	118		7	
	Channel 23 -		119		24	
	Channel 23gnd shld		128 (A2)		40	
S7-STP-F4	Channel 24 +	PSW-A6	112		8	
	Channel 24 -		120		25	
	Channel 24gnd shld		128 (A2)		41	
	GND WIRE		128 (A2)	9		
S7-STP-G1	Channel 25 +	PSW-G5	90		26	
	Channel 25 -		79		10	
	Channel 25gnd shld		128 (A2)		43	
S7-STP-G2	Channel 26 +	PSW-H6	102		27	
	Channel 26 -		101		11	
	Channel 26gnd shld		128 (A2)		44	
S7-STP-G3	Channel 27 +	PSW-J6	92		28	
	Channel 27 -		91		12	
	Channel 27gnd shld		128 (A2)		45	
S7-STP-G4	Channel 28 +	PSW-F6	103		29	
	Channel 28 -		113		13	
	Channel 28gnd shld		128 (A2)		46	
S7-STP-H1	Channel 29 +	PSW-G6	58		30	
	Channel 29 -		46		14	



SPIRE HARNESS DEFINITION DOCUMENT

Doc: SPIRE-RAL-PRJ-000608
Issue: 1.2
Date: 17/02/05
Page 73 of 245

	Name		128Way #7	DCU P11	DCU P12	DCU P13
	Channel 29gnd shld		128 (A2)		47	
S7-STP-H2	Channel 30 +	PSW-H7	68		31	
	Channel 30 -		57		15	
	Channel 30gnd shld		128 (A2)		48	
S7-STP-H3	Channel 31 +	PSW-F7	69		32	
	Channel 31 -		80		16	
	Channel 31gnd shld		128 (A2)		49	
S7-STP-H4	Channel 32 +	PSW-J7	70		33	
	Channel 32 -		81		17	
	Channel 32gnd shld		128 (A2)		50	
S7-STP-I1	Channel 33 +	PSW-G7	23			1
	Channel 33 -		34			18
	Channel 33gnd shld		4 (A3)			34
S7-STP-I2	Channel 34 +	PSW-H8	33			2
	Channel 34 -		45			19
	Channel 34gnd shld		4 (A3)			35
S7-STP-I3	Channel 35 +	PSW-F8	44			3
	Channel 35 -		56			20
	Channel 35gnd shld		4 (A3)			36
S7-STP-I4	Channel 36 +	PSW-G8	22			4
	Channel 36 -		32			21
	Channel 36gnd shld		4 (A3)			37
S7-STP-J1	Channel 37 +	PSW-J8	13			5
	Channel 37 -		12			22
	Channel 37gnd shld		4 (A3)			38
S7-STP-J2	Channel 38 +	PSW-F9	21			6
	Channel 38 -		20			23
	Channel 38gnd shld		4 (A3)			39
S7-STP-J3	Channel 39 +	PSW-H9	31			7
	Channel 39 -		43			24
	Channel 39gnd shld		4 (A3)			40
S7-STP-J4	Channel 40 +	PSW-G9	42			8
	Channel 40 -		54			25
	Channel 40gnd shld		4 (A3)			41
	GND WIRE		4 (A3)			9
S7-STP-K1	Channel 41 +	PSW-J9	10			26
	Channel 41 -		11			10
	Channel 41gnd shld		4 (A3)			43
S7-STP-K2	Channel 42 +	PSW-F10	19			27
	Channel 42 -		29			11
	Channel 42gnd shld		4 (A3)			44
S7-STP-K3	Channel 43 +	PSW-H10	41			28
	Channel 43 -		30			12
	Channel 43gnd shld		4 (A3)			45
S7-STP-K4	Channel 44 +	PSW-G10	53			29
	Channel 44 -		52			13
	Channel 44gnd shld		4 (A3)			46
S7-STP-L1	Channel 45 +	PSW-F11	9			30
	Channel 45 -		17			14
	Channel 45gnd shld		4 (A3)			47
S7-STP-L2	Channel 46 +	PSW-J10	18			31
	Channel 46 -		28			15
	Channel 46gnd shld		4 (A3)			48
S7-STP-L3	Channel 47 +	PSW-H11	16			32
	Channel 47 -		27			16
	Channel 47gnd shld		4 (A3)			49
S7-STP-L4	Channel 48 +	PSW-G11	40			33
	Channel 48 -		39			17
	Channel 48gnd shld		4 (A3)			50
	Harness Overshield		EMC Backshell	EMC Backshell	EMC Backshell	EMC Backshell

FPU Faraday Shield Link Pins												
1	2	3	5	6	7	8	14	15	24	25	35	82
93	94	104	105	114	115	121	122	123	124	125	126	127

4.2.8 S8 SVM-CB 8 – DRCU (Type 1) PSW

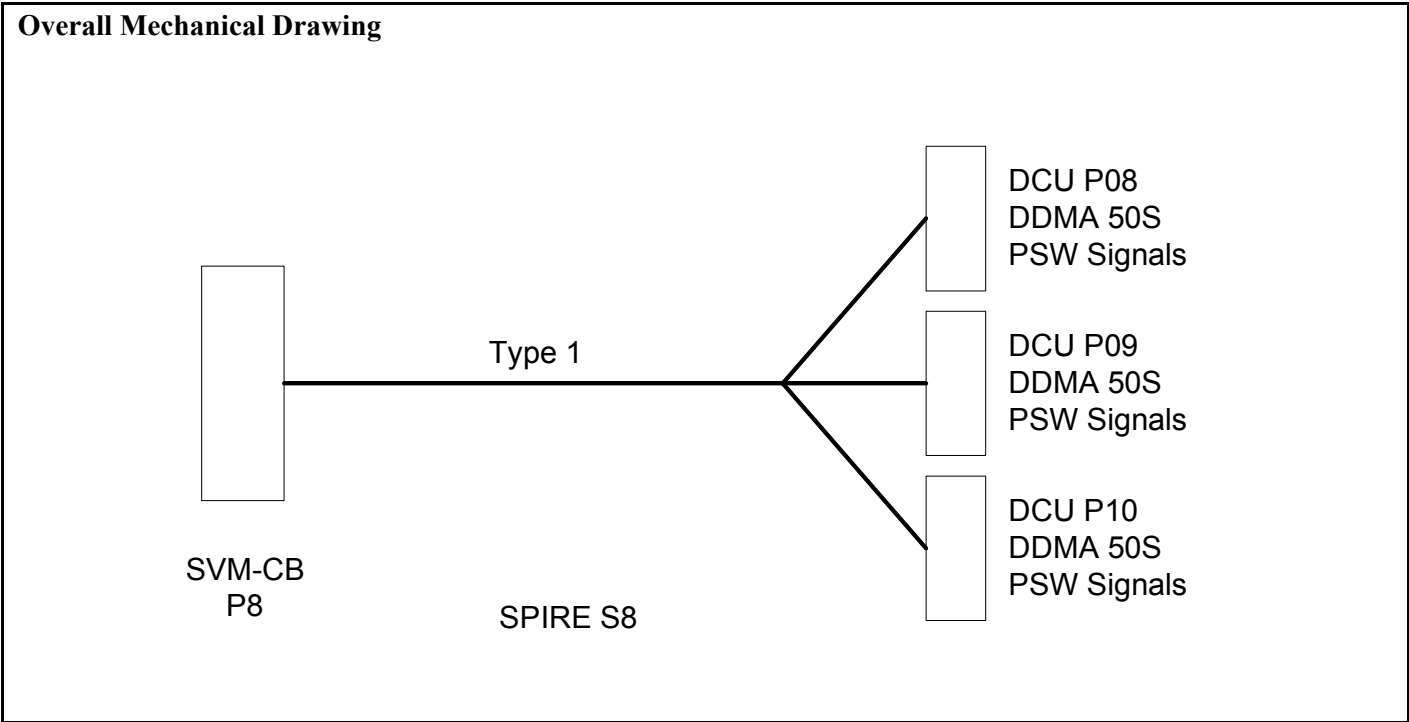

Connector/Backshell Details

DDMA50S+Glenair557-B-357-M-5toDCUJ8	DCU-JFP
DDMA50S+Glenair557-E-359-M-5toDCUJ9	DCU-JFP
DDMA50S+Glenair557-B-357-M-5toDCUJ10	DCU-JFP

Harness Layup

As S5 except
 Tail A = HSDCU P08
 Tail B = HSDCU P09
 Tail C = HSDCU P10

Table 4.2-8 - SIH-SS-08 Listing

	Name	Pixel	128Way #8	DCU P08	DCU P09	DCU P10
	Ground Pin		47 (A4)			
S8-STP-A1	Channel 1 +	PSW-D6	26	1		
	Channel 1 -		37	18		
	Channel 1gnd shld		36 (A1)	34		
S8-STP-A2	Channel 2 +	PSW-B6	38	2		
	Channel 2 -		49	19		
	Channel 2gnd shld		36 (A1)	35		
S8-STP-A3	Channel 3 +	PSW-C5	48	3		
	Channel 3 -		60	20		
	Channel 3gnd shld		36 (A1)	36		
S8-12-ax-A4	Channel 4 +	PSW-A5	59	4		
	Channel 4 -		71	21		
	Channel 4gnd shld		36 (A1)	37		
S8-STP-B1	Channel 5 +	PSW-E5	50	5		
	Channel 5 -		61	22		
	Channel 5gnd shld		36 (A1)	38		



SPIRE HARNESS DEFINITION DOCUMENT

Doc: SPIRE-RAL-PRJ-000608
Issue: 1.2
Date: 17/02/05
Page 75 of 245

	Name	Pixel	128Way #8	DCU P08	DCU P09	DCU P10
S8-STP-B2	Channel 6 +	PSW-B5	62	6		
	Channel 6 -		51	23		
	Channel 6gnd shld		36 (A1)	39		
S8-STP-B3	Channel 7 +	PSW-D5	63	7		
	Channel 7 -		75	24		
	Channel 7gnd shld		36 (A1)	40		
S8-STP-B4	Channel 8 +	PSW-C4	74	8		
	Channel 8 -		73	25		
	Channel 8gnd shld		36 (A1)	41		
	GND WIRE		36 (A1)	9		
S8-STP-C1	Channel 9 +	PSW-A4	83	26		
	Channel 9 -		72	10		
	Channel 9gnd shld		36 (A1)	43		
S8-STP-C2	Channel 10 +	PSW-D4	95	27		
	Channel 10 -		84	11		
	Channel 10gnd shld		36 (A1)	44		
S8-STP-C3	Channel 11 +	PSW-B4	96	28		
	Channel 11 -		85	12		
	Channel 11gnd shld		36 (A1)	45		
S8-STP-C4	Channel 12 +	PSW-C3	106	29		
	Channel 12 -		107	13		
	Channel 12gnd shld		36 (A1)	46		
S8-STP-D1	Channel 13 +	PSW-B3	86	30		
	Channel 13 -		87	14		
	Channel 13gnd shld		36 (A1)	47		
S8-STP-D2	Channel 14 +	PSW-A3	97	31		
	Channel 14 -		98	15		
	Channel 14gnd shld		36 (A1)	48		
S8-STP-D3	Channel 15 +	PSW-A2	108	32		
	Channel 15 -		109	16		
	Channel 15gnd shld		36 (A1)	49		
S8-STP-D4	Channel 16 +	PSW-D3	116	33		
	Channel 16 -		117	17		
	Channel 16gnd shld		36 (A1)	50		
S8-STP-E1	Channel 17 +	PSW-C2	55		1	
	Channel 17 -		66		18	
	Channel 17gnd shld		128 (A2)		34	
S8-STP-E2	Channel 18 +	PSW-B2	67		2	
	Channel 18 -		78		19	
	Channel 18gnd shld		128 (A2)		35	
S8-STP-E3	Channel 19 +	PSW-D2	76		3	
	Channel 19 -		77		20	
	Channel 19gnd shld		128 (A2)		36	
S8-STP-E4	Channel 20 +	PSW-A1	88		4	
	Channel 20 -		89		21	
	Channel 20gnd shld		128 (A2)		37	
S8-STP-F1	Channel 21 +	PSW-C1	99		5	
	Channel 21 -		100		22	
	Channel 21gnd shld		128 (A2)		38	
S8-STP-F2	Channel 22 +	PSW-B1	110		6	
	Channel 22 -		111		23	
	Channel 22gnd shld		128 (A2)		39	
S8-STP-F3	Channel 23 +	PSW-DK1	118		7	
	Channel 23 -		119		24	
	Channel 23gnd shld		128 (A2)		40	
S8-STP-F4	Channel 24 +	PSW-D1	112		8	
	Channel 24 -		120		25	
	Channel 24gnd shld		128 (A2)		41	
	GND WIRE		128 (A2)		9	
S8-STP-G1	Channel 25 +	PSW-F12	90		26	
	Channel 25 -		79		10	
	Channel 25gnd shld		128 (A2)		43	
S8-STP-G2	Channel 26 +	PSW-J11	102		27	
	Channel 26 -		101		11	
	Channel 26gnd shld		128 (A2)		44	
S8-STP-G3	Channel 27 +	PSW-E12	92		28	
	Channel 27 -		91		12	
	Channel 27gnd shld		128 (A2)		45	
S8-STP-G4	Channel 28 +	PSW-H12	103		29	
	Channel 28 -		113		13	
	Channel 28gnd shld		128 (A2)		46	



SPIRE HARNESS DEFINITION DOCUMENT

Doc: SPIRE-RAL-PRJ-000608
Issue: 1.2
Date: 17/02/05
Page 76 of 245

	Name	Pixel	128Way #8	DCU P08	DCU P09	DCU P10
S8-STP-H1	Channel 29 +	PSW-G12	58		30	
	Channel 29 -		46		14	
	Channel 29gnd shld		128 (A2)		47	
S8-STP-H2	Channel 30 +	PSW-F13	68		31	
	Channel 30 -		57		15	
	Channel 30gnd shld		128 (A2)		48	
S8-STP-H3	Channel 31 +	PSW-E13	69		32	
	Channel 31 -		80		16	
	Channel 31gnd shld		128 (A2)		49	
S8-STP-H4	Channel 32 +	PSW-J12	70		33	
	Channel 32 -		81		17	
	Channel 32gnd shld		128 (A2)		50	
S8-STP-I1	Channel 33 +	PSW-H13	23			1
	Channel 33 -		34			18
	Channel 33gnd shld		4 (A3)			34
S8-STP-I2	Channel 34 +	PSW-G13	33			2
	Channel 34 -		45			19
	Channel 34gnd shld		4 (A3)			35
S8-STP-I3	Channel 35 +	PSW-F14	44			3
	Channel 35 -		56			20
	Channel 35gnd shld		4 (A3)			36
S8-STP-I4	Channel 36 +	PSW-E14	22			4
	Channel 36 -		32			21
	Channel 36gnd shld		4 (A3)			37
S8-STP-J1	Channel 37 +	PSW-J13	13			5
	Channel 37 -		12			22
	Channel 37gnd shld		4 (A3)			38
S8-STP-J2	Channel 38 +	PSW-H14	21			6
	Channel 38 -		20			23
	Channel 38gnd shld		4 (A3)			39
S8-STP-J3	Channel 39 +	PSW-G14	31			7
	Channel 39 -		43			24
	Channel 39gnd shld		4 (A3)			40
S8-STP-J4	Channel 40 +	PSW-J14	42			8
	Channel 40 -		54			25
	Channel 40gnd shld		4 (A3)			41
	GND WIRE		4 (A3)			9
S8-STP-K1	Channel 41 +	PSW-F15	10			26
	Channel 41 -		11			10
	Channel 41gnd shld		4 (A3)			43
S8-STP-K2	Channel 42 +	PSW-H15	19			27
	Channel 42 -		29			11
	Channel 42gnd shld		4 (A3)			44
S8-STP-K3	Channel 43 +	PSW-J15	41			28
	Channel 43 -		30			12
	Channel 43gnd shld		4 (A3)			45
S8-STP-K4	Channel 44 +	PSW-G15	53			29
	Channel 44 -		52			13
	Channel 44gnd shld		4 (A3)			46
S8-STP-L1	Channel 45 +	PSW-H16	9			30
	Channel 45 -		17			14
	Channel 45gnd shld		4 (A3)			47
S8-STP-L2	Channel 46 +	PSW-DK2	18			31
	Channel 46 -		28			15
	Channel 46gnd shld		4 (A3)			48
S8-STP-L3	Channel 47 +	PSW-F16	16			32
	Channel 47 -		27			16
	Channel 47gnd shld		4 (A3)			49
S8-STP-L4	Channel 48 +	PSW-E15	40			33
	Channel 48 -		39			17
	Channel 48gnd shld		4 (A3)			50
	Harness Overshield		EMC Backshell	EMC Backshell	EMC Backshell	EMC Backshell

FPU Faraday Shield Link Pins												
1	2	3	5	6	7	8	14	15	24	25	35	82
93	94	104	105	114	115	121	122	123	124	125	126	127

4.2.9 S9 SVM-CB 9 – DRCU (Type 1) PSW

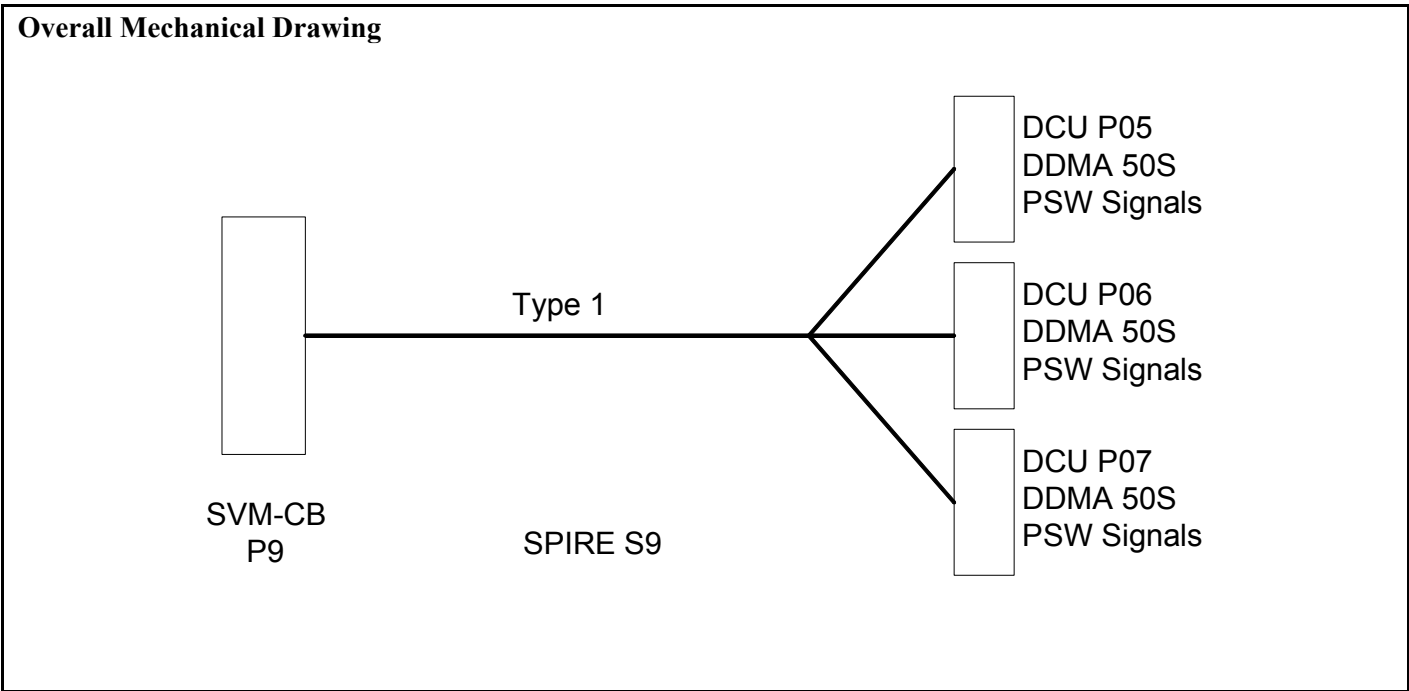

Connector/Backshell Details

DDMA50S+Glenair557-E-359-M-5toDCUJ5	DCU-JFP
DDMA50S+Glenair557-B-357-M-5toDCUJ6	DCU-JFP
DDMA50S+Glenair557-E-359-M-5toDCUJ7	DCU-JFP

Harness Layup

As S5 except
 Tail A = HSDCU P5
 Tail B = HSDCU P6
 Tail C = HSDCU P7

Table 4.2-9 - SIH-SS-09 Listing

	Name	Pixel	128Way #9	DCU P05	DCU P06	DCU P07
	Ground Pin		47 (A4)			
S9-STP-A1	Channel 1 +	PSW-R1	26	1		
	Channel 1 -		37	18		
	Channel 1gnd shld		36 (A1)	34		
S9-STP-A2	Channel 2 +	PSW-D16	38	2		
	Channel 2 -		49	19		
	Channel 2gnd shld		36 (A1)	35		
S9-STP-A3	Channel 3 +	PSW-T1	48	3		
	Channel 3 -		60	20		
	Channel 3gnd shld		36 (A1)	36		
S9-STP-A4	Channel 4 +	PSW-B16	59	4		
	Channel 4 -		71	21		
	Channel 4gnd shld		36 (A1)	37		
S9-STP-B1	Channel 5 +	PSW-C15	50	5		
	Channel 5 -		61	22		
	Channel 5gnd shld		36 (A1)	38		



SPIRE HARNESS DEFINITION DOCUMENT

Doc: SPIRE-RAL-PRJ-000608
Issue: 1.2
Date: 17/02/05
Page 78 of 245

	Name	Pixel	128Way #9	DCU P05	DCU P06	DCU P07
S9-STP-B2	Channel 6 +	PSW-A15	62	6		
	Channel 6 -		51	23		
	Channel 6gnd shld		36 (A1)	39		
S9-STP-B3	Channel 7 +	PSW-D15	63	7		
	Channel 7 -		75	24		
	Channel 7gnd shld		36 (A1)	40		
S9-STP-B4	Channel 8 +	PSW-B15	74	8		
	Channel 8 -		73	25		
	Channel 8gnd shld		36 (A1)	41		
	GND WIRE		36 (A1)	9		
S9-STP-C1	Channel 9 +	PSW-C14	83	26		
	Channel 9 -		72	10		
	Channel 9gnd shld		36 (A1)	43		
S9-STP-C2	Channel 10 +	PSW-D14	95	27		
	Channel 10 -		84	11		
	Channel 10gnd shld		36 (A1)	44		
S9-STP-C3	Channel 11 +	PSW-A14	96	28		
	Channel 11 -		85	12		
	Channel 11gnd shld		36 (A1)	45		
S9-STP-C4	Channel 12 +	PSW-A13	106	29		
	Channel 12 -		107	13		
	Channel 12gnd shld		36 (A1)	46		
S9-STP-D1	Channel 13 +	PSW-B14	86	30		
	Channel 13 -		87	14		
	Channel 13gnd shld		36 (A1)	47		
S9-STP-D2	Channel 14 +	PSW-C13	97	31		
	Channel 14 -		98	15		
	Channel 14gnd shld		36 (A1)	48		
S9-STP-D3	Channel 15 +	PSW-B13	108	32		
	Channel 15 -		109	16		
	Channel 15gnd shld		36 (A1)	49		
S9-STP-D4	Channel 16 +	PSW-D13	116	33		
	Channel 16 -		117	17		
	Channel 16gnd shld		36 (A1)	50		
S9-STP-E1	Channel 17 +	PSW-A12	55		1	
	Channel 17 -		66		18	
	Channel 17gnd shld		128 (A2)		34	
S9-STP-E2	Channel 18 +	PSW-C12	67		2	
	Channel 18 -		78		19	
	Channel 18gnd shld		128 (A2)		35	
S9-STP-E3	Channel 19 +	PSW-D12	76		3	
	Channel 19 -		77		20	
	Channel 19gnd shld		128 (A2)		36	
S9-STP-E4	Channel 20 +	PSW-B12	88		4	
	Channel 20 -		89		21	
	Channel 20gnd shld		128 (A2)		37	
S9-STP-F1	Channel 21 +	PSW-E11	99		5	
	Channel 21 -		100		22	
	Channel 21gnd shld		128 (A2)		38	
S9-STP-F2	Channel 22 +	PSW-A11	110		6	
	Channel 22 -		111		23	
	Channel 22gnd shld		128 (A2)		39	
S9-STP-F3	Channel 23 +	PSW-C11	118		7	
	Channel 23 -		119		24	
	Channel 23gnd shld		128 (A2)		40	
S9-STP-F4	Channel 24 +	PSW-B11	112		8	
	Channel 24 -		120		25	
	Channel 24gnd shld		128 (A2)		41	
	GND WIRE		128 (A2)		9	
S9-STP-G1	Channel 25 +	PSW-E1	90		26	
	Channel 25 -		79		10	
	Channel 25gnd shld		128 (A2)		43	
S9-STP-G2	Channel 26 +	PSW-F1	102		27	
	Channel 26 -		101		11	
	Channel 26gnd shld		128 (A2)		44	
S9-STP-G3	Channel 27 +	PSW-T2	92		28	
	Channel 27 -		91		12	
	Channel 27gnd shld		128 (A2)		45	
S9-STP-G4	Channel 28 +	PSW-H1	103		29	
	Channel 28 -		113		13	
	Channel 28gnd shld		128 (A2)		46	



SPIRE HARNESS DEFINITION DOCUMENT

Doc: SPIRE-RAL-PRJ-000608
Issue: 1.2
Date: 17/02/05
Page 79 of 245

	Name	Pixel	128Way #9	DCU P05	DCU P06	DCU P07
S9-STP-H1	Channel 29 +	PSW-G1	58		30	
	Channel 29 -		46		14	
	Channel 29gnd shld		128 (A2)		47	
S9-STP-H2	Channel 30 +	PSW-J1	68		31	
	Channel 30 -		57		15	
	Channel 30gnd shld		128 (A2)		48	
S9-STP-H3	Channel 31 +	PSW-H2	69		32	
	Channel 31 -		80		16	
	Channel 31gnd shld		128 (A2)		49	
S9-STP-H4	Channel 32 +	PSW-F2	70		33	
	Channel 32 -		81		17	
	Channel 32gnd shld		128 (A2)		50	
S9-STP-I1	Channel 33 +	PSW-J2	23			1
	Channel 33 -		34			18
	Channel 33gnd shld		4 (A3)			34
S9-STP-I2	Channel 34 +	PSW-G2	33			2
	Channel 34 -		45			19
	Channel 34gnd shld		4 (A3)			35
S9-STP-I3	Channel 35 +	PSW-H3	44			3
	Channel 35 -		56			20
	Channel 35gnd shld		4 (A3)			36
S9-STP-I4	Channel 36 +	PSW-J3	22			4
	Channel 36 -		32			21
	Channel 36gnd shld		4 (A3)			37
S9-STP-J1	Channel 37 +	PSW-E2	13			5
	Channel 37 -		12			22
	Channel 37gnd shld		4 (A3)			38
S9-STP-J2	Channel 38 +	PSW-F3	21			6
	Channel 38 -		20			23
	Channel 38gnd shld		4 (A3)			39
S9-STP-J3	Channel 39 +	PSW-G3	31			7
	Channel 39 -		43			24
	Channel 39gnd shld		4 (A3)			40
S9-STP-J4	Channel 40 +	PSW-H4	42			8
	Channel 40 -		54			25
	Channel 40gnd shld		4 (A3)			41
	GND WIRE		4 (A3)			9
S9-STP-K1	Channel 41 +	PSW-J4	10			26
	Channel 41 -		11			10
	Channel 41gnd shld		4 (A3)			43
S9-STP-K2	Channel 42 +	PSW-E3	19			27
	Channel 42 -		29			11
	Channel 42gnd shld		4 (A3)			44
S9-STP-K3	Channel 43 +	PSW-F4	41			28
	Channel 43 -		30			12
	Channel 43gnd shld		4 (A3)			45
S9-STP-K4	Channel 44 +	PSW-G4	53			29
	Channel 44 -		52			13
	Channel 44gnd shld		4 (A3)			46
S9-STP-L1	Channel 45 +	PSW-H5	9			30
	Channel 45 -		17			14
	Channel 45gnd shld		4 (A3)			47
S9-STP-L2	Channel 46 +	PSW-E4	18			31
	Channel 46 -		28			15
	Channel 46gnd shld		4 (A3)			48
S9-STP-L3	Channel 47 +	PSW-J5	16			32
	Channel 47 -		27			16
	Channel 47gnd shld		4 (A3)			49
S9-STP-L4	Channel 48 +	PSW-F5	40			33
	Channel 48 -		39			17
	Channel 48gnd shld		4 (A3)			50
	Harness Overshield		EMC Backshell	EMC Backshell	EMC Backshell	EMC Backshell

FPU Faraday Shield Link Pins												
1	2	3	5	6	7	8	14	15	24	25	35	82
93	94	104	105	114	115	121	122	123	124	125	126	127



SPIRE HARNESS DEFINITION DOCUMENT

Doc: SPIRE-RAL-PRJ-000608
 Issue: 1.2
 Date: 17/02/05
 Page 80 of 245

4.2.10 S10 SVM-CB 10 – DRCU AUX-P

Overall Mechanical Drawing

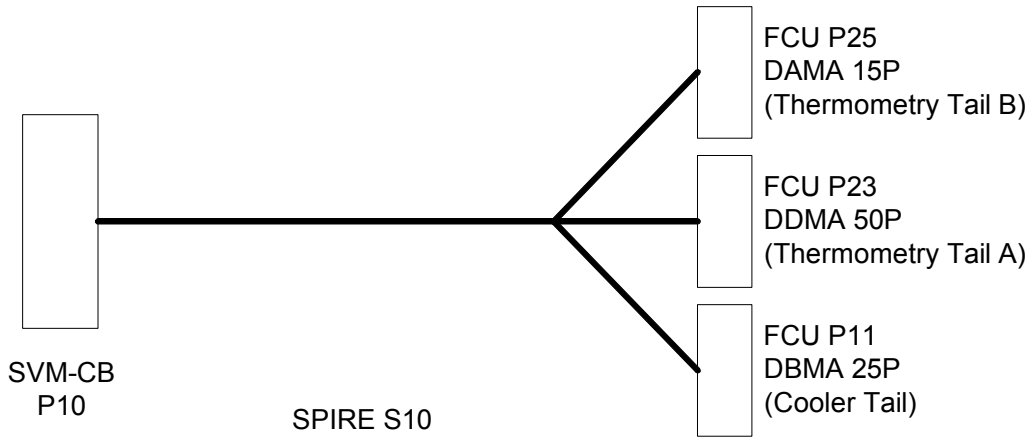

Connector/Backshell Details

Prime side harness

DBMA 25P + Glenair 557-E-359-M-3	to FCU J11 Cooler Tail (Prime)
DDMA 50P + Glenair 557-E-359-M-5	to FCU J23 FPU Thermometry Tail A (Prime)
DAMA 15P + Glenair 557-E-359-M-2	to FCU J25 FPU Thermometry Tail B (Prime)

Heaters (FCU P11)

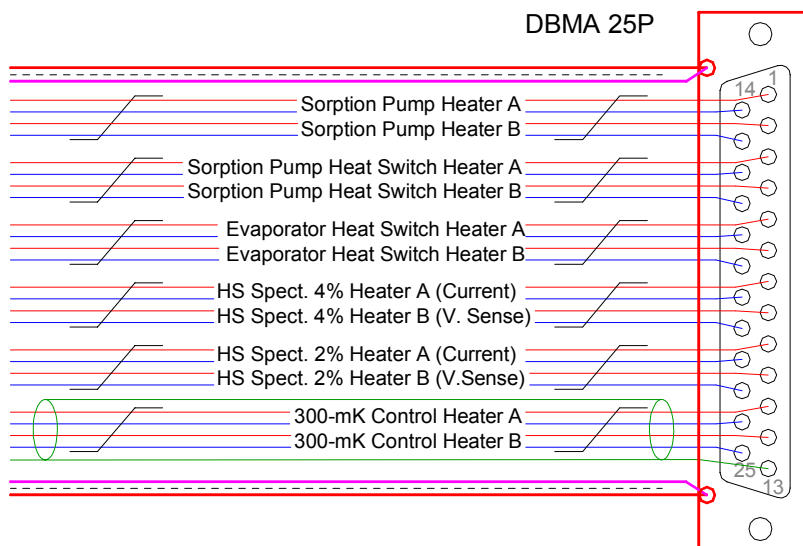

Heaters FCU P11

- 5 TQ
- 1 STQ
- See Section 4.2 for details regarding the implementation of the shields.
- No harness bundle overall insulation baselined. May be added later by locally wrapping with insulation at contact points.



SPIRE HARNESS DEFINITION DOCUMENT

Doc: SPIRE-RAL-PRJ-000608
Issue: 1.2
Date: 17/02/05
Page 81 of 245

FPU Thermometry Tail B (FCU J25)

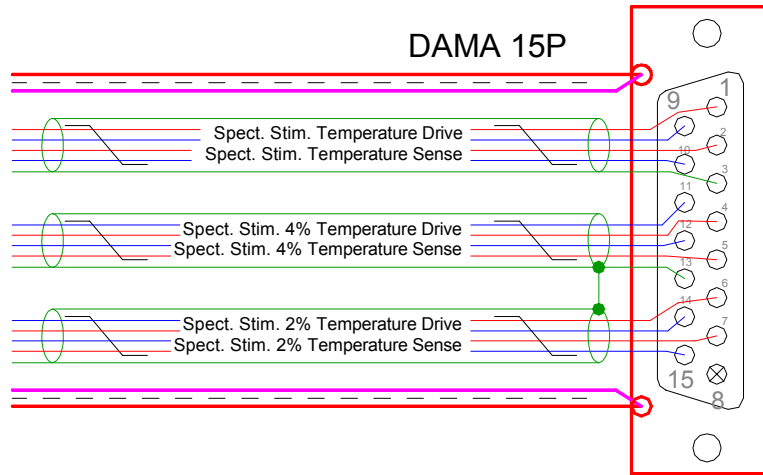

FPU Thermometry B (FCU P25/P26)

- Three STQ
- See Section 4.2 for details regarding the implementation of the shields.
- No harness bundle overall insulation baselined. May be added later by locally wrapping with insulation at contact points.

FPU Thermometry Tail A (FCU P23)

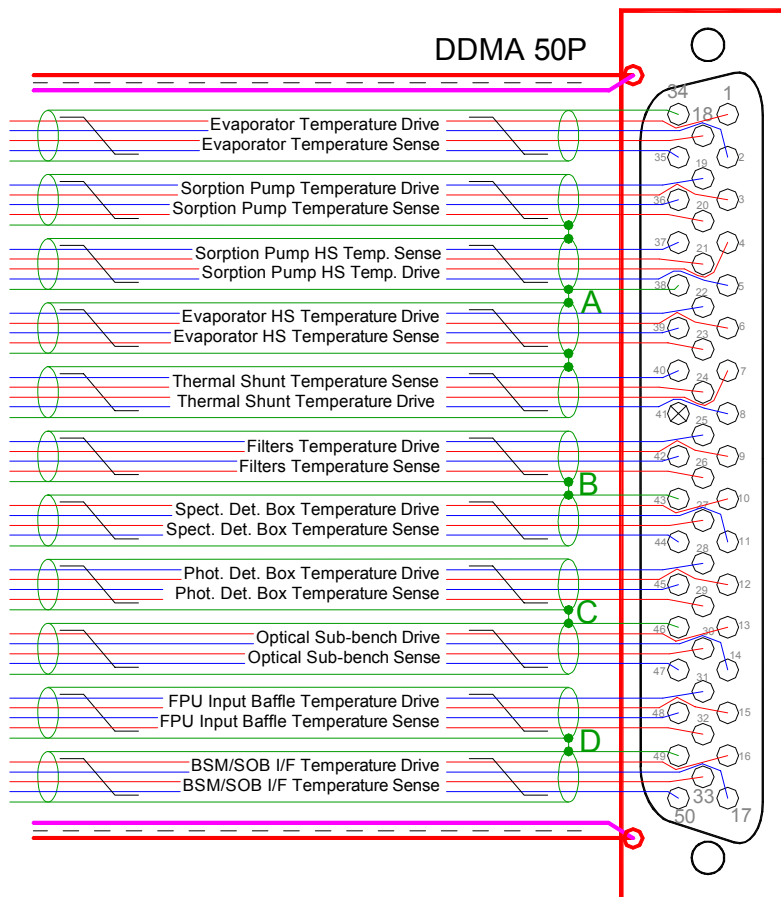

FPU Thermometry A (FCU P23/P24)

- 11 STQ
- 1 Single
- See Section 4.2 for details regarding the implementation of the shields.
- No harness bundle overall insulation baselined. May be added later by locally wrapping with insulation at contact points.



SPIRE HARNESS DEFINITION DOCUMENT

Doc: SPIRE-RAL-PRJ-000608

Issue: 1.2

Date: 17/02/05

Page 82 of 245

SVM-CB S10 128-Way Pin Allocations (View of wiring side of connector)

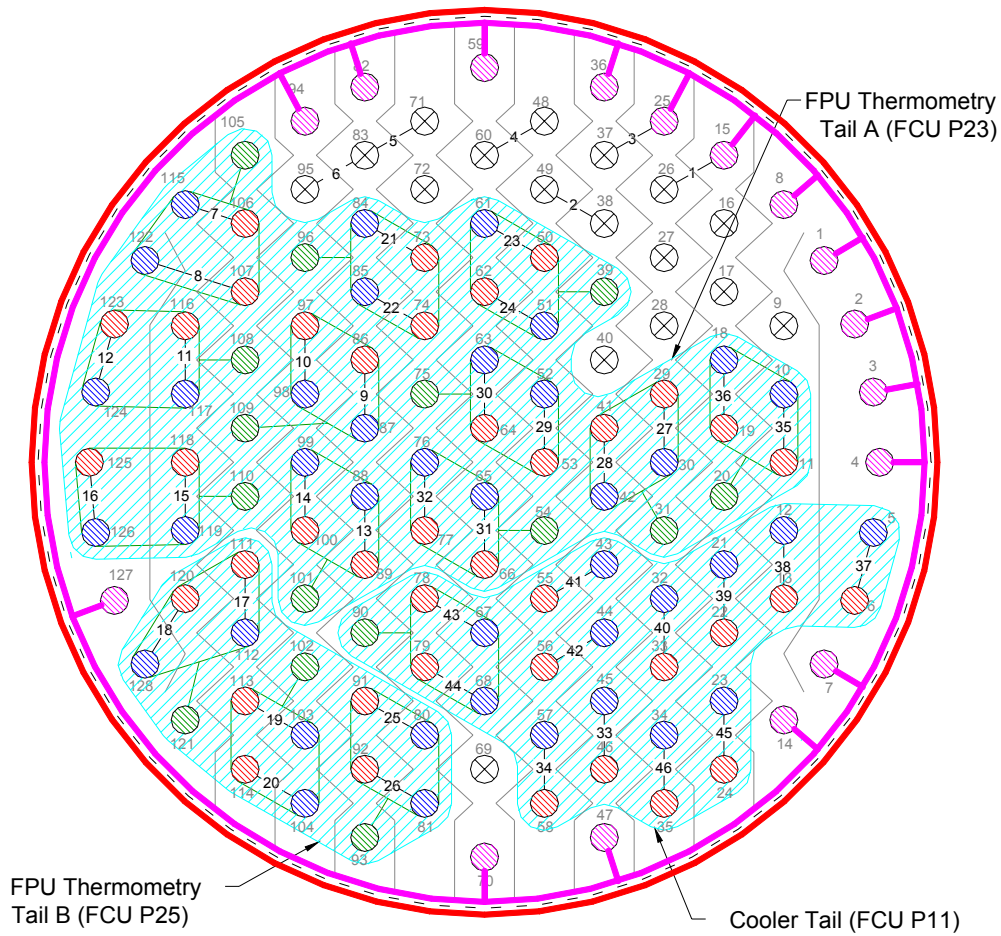

- Shields of STP and STQ are commoned as indicated by signal ground connections and passed through the 128-way by a dedicated ground pin.

- Signal Supply Pin
- Signal Return Pin
- Signal Ground Pin
- FPU Faraday Shield Link Pin
- No Connection
- Harness Tails
- Harness Overshield
- Insulating Jacket
- FPU Faraday Shield
- Ground Plane Interconnection



SPIRE HARNESS DEFINITION DOCUMENT

Doc: SPIRE-RAL-PRJ-000608
 Issue: 1.2
 Date: 17/02/05
 Page 83 of 245

S10 128-Way FPU Thermometry Tail A Pin Allocation

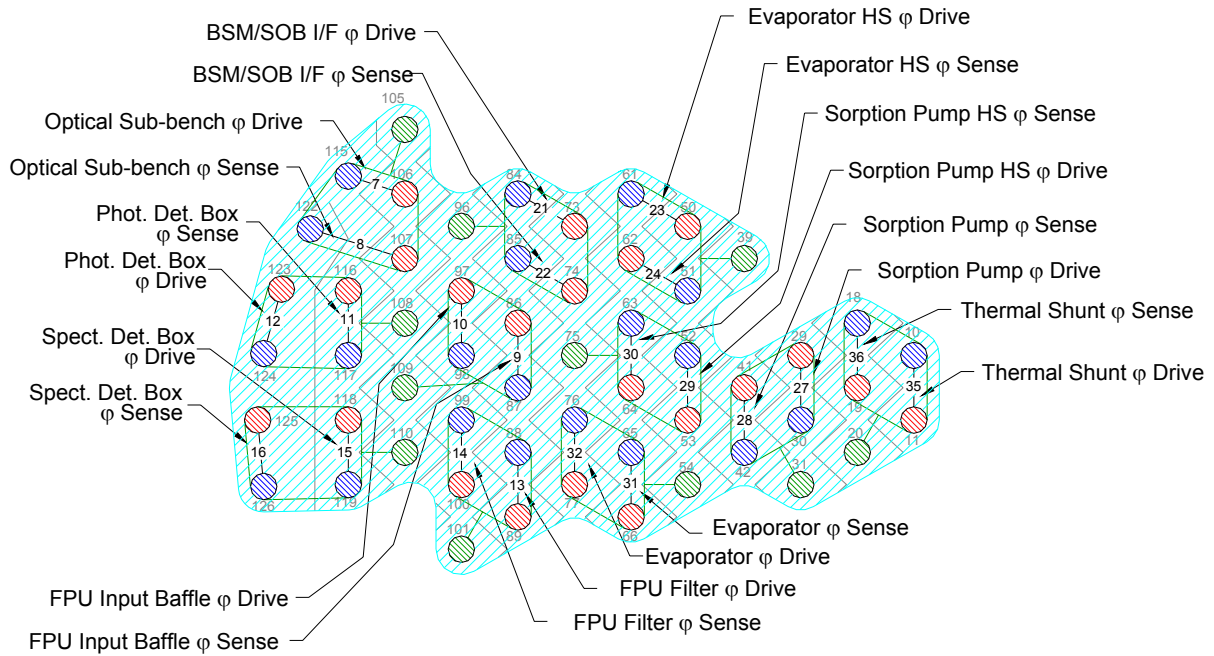

FPU Thermometry Tail A (FCU P23)

S10 128-Way FPU Thermometry Tail B Pin Allocation

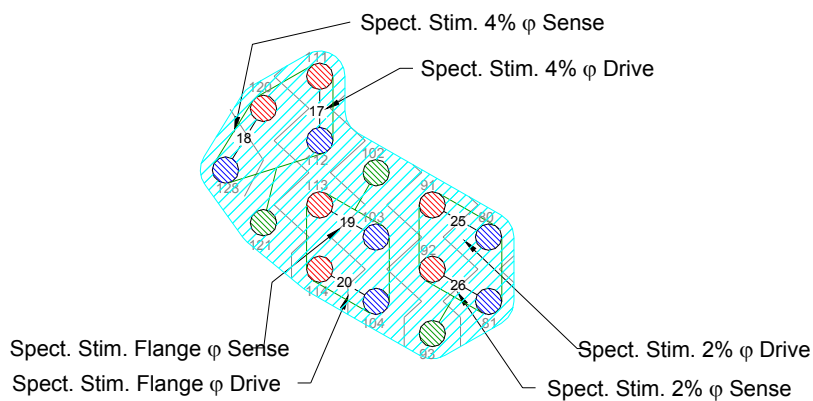

FPU Thermometry Tail B (FCU P25)



SPIRE HARNESS DEFINITION DOCUMENT

Doc: SPIRE-RAL-PRJ-000608
Issue: 1.2
Date: 17/02/05
Page 84 of 245

S10 128-Way Cooler Tail Pin Allocation

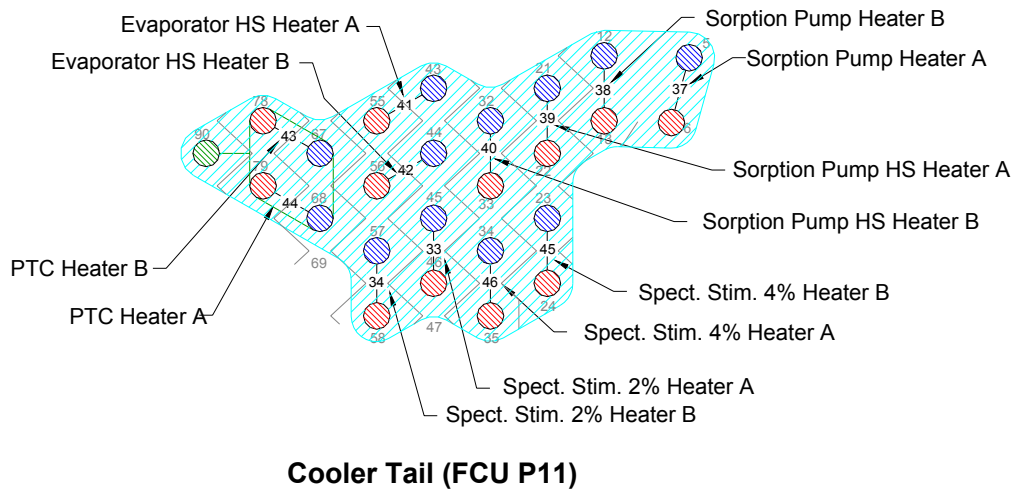

Table 4.2-10- SIH-SS-10 Cooler Tail Listing P11

Function	Signal Name	25way P11	Max. Current	Wire Lay-up	Max Ohms	128Way #10
Sorption Pump Heater I+ A	SPheater_D+A	1	25 mA	Twisted quad	10	6
Sorption Pump Heater I+ B	SPheater_D+B	2	25 mA		10	13
Sorption Pump Heater I- A	SPheater_D-A	14	25 mA		10	5
Sorption Pump Heater I- B	SPheater_D-B	15	25 mA		10	12
Sorption Pump Heat Switch Heater I+ A	SPHSheater_D+A	3	1.5 mA	Twisted quad	50	22
Sorption Pump Heat Switch Heater I+ B	SPHSheater_D+B	4	1.5 mA		50	33
Sorption Pump Heat Switch Heater I- A	SPHSheater_D-A	16	1.5 mA		50	21
Sorption Pump Heat Switch Heater I- B	SPHSheater_D-B	17	1.5 mA		50	32
Evaporator Heat Switch Heater I+ A	EVHSheater_D+A	5	1.5 mA	Twisted quad	50	55
Evaporator Heat Switch Heater I+ B	EVHSheater_D+B	6	1.5 mA		50	56
Evaporator Heat Switch Heater I- A	EVHSheater_D-A	18	1.5 mA		50	43
Evaporator Heat Switch Heater I- B	EVHSheater_D-B	19	1.5 mA		50	44
HS Spect. 4% Heater I+ A	Spect4heaterD+A	7	9 mA	Twisted quad	30	35
HS Spect. 4% Heater V+ B	Spect4heaterD+B	8	9 mA		30	24
HS Spect. 4% Heater I- A	Spect4heaterD-A	20	9 mA		30	34
HS Spect. 4% Heater V- B	Spect4heaterD-B	21	9 mA		30	23
HS Spect. 2% Heater I+ A	Spect2heaterD+A	9	7 mA	Twisted quad	30	46
HS Spect. 2% Heater V+ B	Spect2heaterD+B	10	7 mA		30	58
HS Spect. 2% Heater I- A	Spect2heaterD-A	22	7 mA		30	45
HS Spect. 2% Heater V- B	Spect2heaterD-B	23	7 mA		30	57
Phot. Thermal Control Heater I+ A	TcheaterD+A	11	2mA	Insulated Screened Twisted quad	100	79
Phot. Thermal Control Heater I+ B	TcheaterD+B	12	2 mA		100	78
Phot. Thermal Control Heater I- A	TcheaterD-A	24	2 mA		100	68
Phot. Thermal Control Heater I- B	TcheaterD-B	25	2 mA		100	67
Phot. Thermal Control Heater shld.	Tcheater_shd	13			N/A	90

25ways used



SPIRE HARNESS DEFINITION DOCUMENT

Doc: SPIRE-RAL-PRJ-000608
Issue: 1.2
Date: 17/02/05
Page 85 of 245

Table 4.2-11 - SIH-SS-10 FPU Thermometry Tail A (FCU P23) Listing

Function	Signal Name	50 way P23	Max. Current	Wire Lay-up	Max Ohms	128Way #10
Evaporator temperature I+	T_CEV_1_D+	1	1 μ A	Insulated screened twisted quad	1000	77
Evaporator temperature V+	T_CEV_1_S+	18	N/A		1000	66
Evaporator temperature V-	T_CEV_1_S-	35	N/A		1000	65
Evaporator temperature I-	T_CEV_1_D-	2	1 μ A		1000	76
Evaporator temperature shld	T_CEV_1_SHD	34	N/A		N/A	54
Sorption Pump temperature I+	T_CPHP_1_D+	3	1 μ A	Insulated screened twisted quad	1000	29
Sorption Pump temperature V+	T_CPHP_1_S+	20	N/A		1000	41
Sorption Pump temperature V-	T_CPHP_1_S-	36	N/A		1000	42
Sorption Pump temperature I-	T_CPHP_1_D-	19	1 μ A		1000	30
Sorption Pump temperature shld	T_TP_1_SHDA	38 (A)	N/A		N/A	31
Sorption Pump Heat Switch temp I+	T_CPHS_1_D+	4	1 μ A	Insulated screened twisted quad	1000	53
Sorption Pump Heat Switch temp V+	T_CPHS_1_S+	21	N/A		1000	64
Sorption Pump Heat Switch temp V-	T_CPHS_1_S-	37	N/A		1000	63
Sorption Pump Heat Switch temp I-	T_CPHS_1_D-	5	1 μ A		1000	52
Sorption Pump Heat Switch temp shld	T_TP_1_SHDA	38 (A)	N/A		N/A	75
Evaporator Heat Switch temperature I+	T_CEHS_1_D+	6	1 μ A	Insulated screened twisted quad	1000	50
Evaporator Heat Switch temperature V+	T_CEHS_1_S+	23	N/A		1000	62
Evaporator Heat Switch temperature V-	T_CEHS_1_S-	39	N/A		1000	51
Evaporator Heat Switch temperature I-	T_CEHS_1_D-	22	1 μ A		1000	61
Evaporator Heat Switch temperature shld	T_TP_1_SHDA	38 (A)	N/A		N/A	39
Thermal Shunt temperature I+ A	T_CSHT_1_D+	7	1 μ A	Insulated screened twisted quad	1000	11
Thermal Shunt temperature V+ B	T_CSHT_1_S+	24	N/A		1000	19
Thermal Shunt temperature V- A	T_CSHT_1_S-	40	N/A		1000	18
Thermal Shunt temperature I- B	T_CSHT_1_D-	8	1 μ A		1000	10
Thermal Shunt temperature shld	T_TP_1_SHDA	38 (A)	N/A		N/A	20
FPU Filter temperature I+	T_SOB_1_D+	9	1 μ A	Insulated screened twisted quad	1000	89
FPU Filter temperature V+	T_SOB_1_S+	26	N/A		1000	100
FPU Filter temperature V-	T_SOB_1_S-	42	N/A		1000	99
FPU Filter temperature I-	T_SOB_1_D-	25	1 μ A		1000	88
FPU Filter temperature shld	T_TP_1_SHDB	43 (B)	N/A		N/A	101
Spectrometer Det. Box temperature I+	T_SLO_1_D+	10	1 μ A	Insulated screened twisted quad	1000	118
Spectrometer Det. Box temperature V+	T_SLO_1_S+	27	N/A		1000	125
Spectrometer Det. Box temperature V-	T_SLO_1_S-	44	N/A		1000	126
Spectrometer Det. Box temperature I-	T_SLO_1_D-	11	1 μ A		1000	119
Spectrometer Det. Box temperature shld	T_TP_1_SHDB	43 (B)	N/A		N/A	110
Photometer Det. Box temperature I+	T_PLO_1_D+	12	1 μ A	Insulated screened twisted quad	1000	123
Photometer Det. Box temperature V+	T_PLO_1_S+	29	N/A		1000	116
Photometer Det. Box temperature V-	T_PLO_1_S-	45	N/A		1000	117
Photometer Det. Box temperature I-	T_PLO_1_D-	28	1 μ A		1000	124
Photometer Det. Box temperature shld	T_TP_1_SHDC	46 (C)	N/A		N/A	108
Optical SubBench temperature I+	T_SUB_1_D+	13	1 μ A	Insulated screened twisted quad	1000	106
Optical SubBench temperature V+	T_SUB_1_S+	30	N/A		1000	107
Optical SubBench temperature V-	T_SUB_1_S-	47	N/A		1000	122
Optical SubBench temperature I-	T_SUB_1_D-	14	1 μ A		1000	115
Optical SubBench temperature shld	T_TP_1_SHDC	46 (C)	N/A		N/A	105
HSFPU Input Baffle temperature I+	T_BAF_1_D+	15	1 μ A	Insulated screened twisted	1000	97
HSFPU Input Baffle temperature V+	T_BAF_1_S+	32	N/A		1000	86
HSFPU Input Baffle temperature V-	T_BAF_1_S-	48	N/A		1000	87
HSFPU Input Baffle temperature I-	T_BAF_1_D-	31	1 μ A		1000	98

Function	Signal Name	50 way P23	Max. Current	Wire Lay-up	Max Ohms	128Way #10
HSFPU Input Baffle temperature shld	T_TP_1_SHDD	49 (D)	N/A	quad	N/A	109
BSM/SOB I/F temperature I+	T_BSMS_1_D+	16	1 μ A	Insulated screened twisted quad	1000	73
BSM/SOB I/F temperature V+	T_BSMS_1_S+	33	N/A		1000	74
BSM/SOB I/F temperature V-	T_BSMS_1_S-	50	N/A		1000	85
BSM/SOB I/F temperature I-	T_BSMS_1_D-	17	1 μ A		1000	84
BSM/SOB I/F temperature shld	T_TP_1_SHDD	49 (D)	N/A		N/A	96
Harness Overshield	EMC Backshell					

Table 4.2-12 - SIH-SS-10 FPU Thermometry Tail B (FCU P25) Listing

Function	Signal Name	15-Way P25	Max. Current	Wire Lay-up	Max Ohms	128Way #10
Spect. Stim. Flange temperature I+	T_SCST_1_D+	1	1 μ A	Insulated screened twisted quad	1000	114
Spect. Stim. Flange temperature V+	T_SCST_1_S+	2	N/A		1000	113
Spect. Stim. Flange temperature V-	T_SCST_1_S-	10	N/A		1000	103
Spect. Stim. Flange temperature I-	T_SCST_1_D-	9	1 μ A		1000	104
Spect. Stim. Flange temperature shld	T_SCST_1_SHD	3	N/A		N/A	102
Spect. Stim. 4% temperature I+	T_SCL4_1_D+	4	1 μ A	Insulated screened twisted quad	1000	111
Spect. Stim. 4% temperature V+	T_SCL4_1_S+	5	N/A		1000	120
Spect. Stim. 4% temperature V-	T_SCL4_1_S-	12	N/A		1000	128
Spect. Stim. 4% temperature I-	T_SCL4_1_D-	11	1 μ A		1000	112
Spect. Stim. 4% temperature shld	T_SCL4_1_SHD	13 (A)	N/A		N/A	121
Spect. Stim. 2% temperature I+	T_SCL2_1_D+	6	1 μ A	Insulated screened twisted quad	1000	91
Spect. Stim. 2% temperature V+	T_SCL2_1_S+	7	N/A		1000	92
Spect. Stim. 2% temperature V-	T_SCL2_1_S-	15	N/A		1000	81
Spect. Stim. 2% temperature I-	T_SCL2_1_D-	14	1 μ A		1000	80
Spect. Stim. 2% temperature shld	T_SCL2_1_SHD	13 (A)	N/A		N/A	93
Harness Overshield	EMC Backshell					

FPU Faraday Shield Link Pins							
1	2	3	4	7	8	14	15
25	36	47	59	70	82	94	127



SPIRE HARNESS DEFINITION DOCUMENT

Doc: SPIRE-RAL-PRJ-000608
Issue: 1.2
Date: 17/02/05
Page 87 of 245

4.2.11 S11 SVM-CB 11 – DRCU DRV-P

Overall Mechanical Drawing

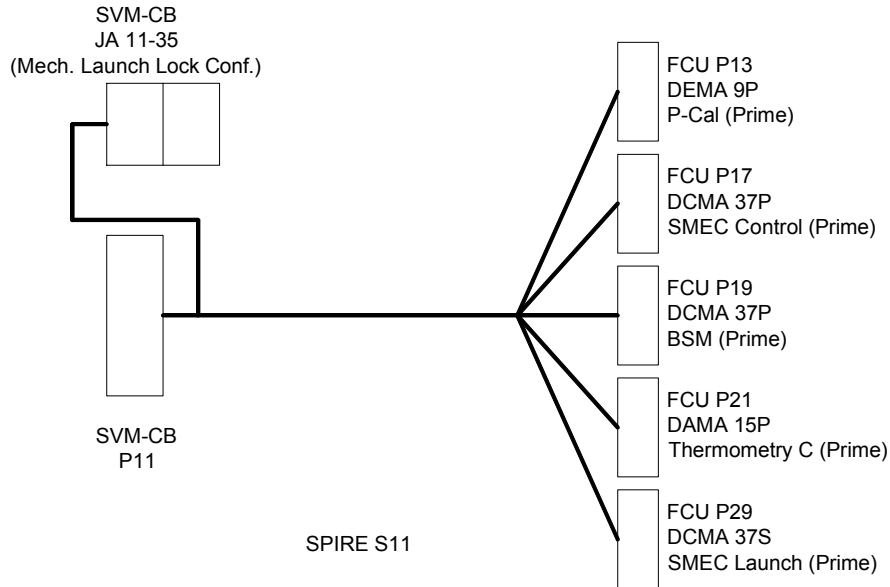

Connector/Backshell Details

DEMA 9 P+Glenair557-T-357-M-1	to	FCUJ13	P-Cal (Prime)
DCMA37P+Glenair557-E-359-M-4	to	FCUJ17	SMEC Control Module (Prime)
DCMA37P+Glenair557-E-359-M-4	to	FCUJ19	BSM Module (Prime)
DAMA 15P+Glenair557-T-357-M-2	to	FCUJ21	Thermometry Tail C (Prime)
DCMA37S+Glenair557-E-359-M-4	to	FCUJ29	SMEC Launch (Prime)
11-35 S + EMI Backshell	to	(PA) Mechanisms Launch Lock Conf.	(Prime)

Shorting Plug

A shorting cap is to be fitted to the JA at all times unless the EGSE is connected. The configuration of this cap is TBD



SPIRE HARNESS DEFINITION DOCUMENT

Doc: SPIRE-RAL-PRJ-000608
 Issue: 1.2
 Date: 17/02/05
 Page 88 of 245

Photometer Stimulus P13

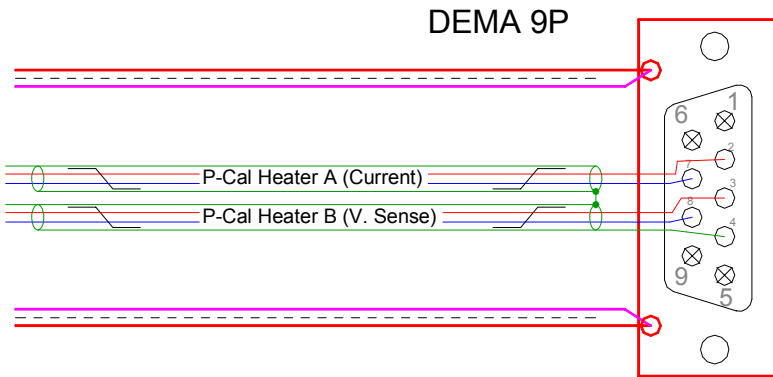

Phot. Stimulus (FCU P13/P14)

- See Section 4.2 for details regarding the implementation of the shields.
- No harness bundle overall insulation baselined. May be added later by locally wrapping with insulation at contact points.

BSM Tail FCU P19

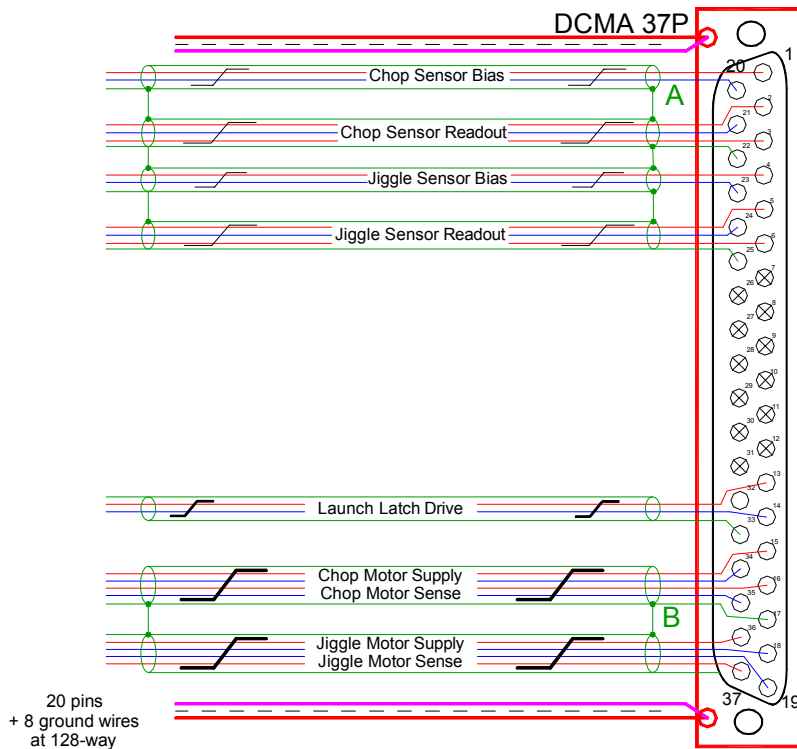

BSM Tail FCU P19

- 4 STP
- 2 STT
- 2 STQ
- See Section 4.2 for details regarding the implementation of the shields.
- No harness bundle overall insulation baselined. May be added later by locally wrapping with insulation at contact points.
- A and B represent the commoning of ground references within the connectors which pass through the 128-way CVV connector on single individual pins.



SPIRE HARNESS DEFINITION DOCUMENT

Doc: SPIRE-RAL-PRJ-000608
 Issue: 1.2
 Date: 17/02/05
 Page 89 of 245

SMEC Launch Tail FCU J29

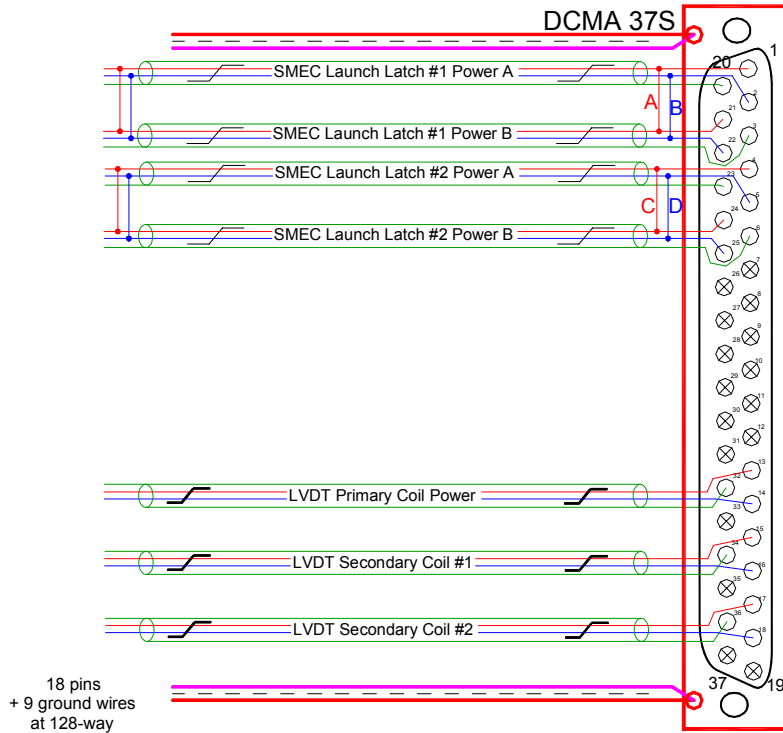

SMEC Launch Tail FCU P29/P30

· 7 STP

· See Section 4.2 for details regarding the implementation of the shields.

· No harness bundle overall insulation baselined. May be added later by locally wrapping with insulation at contact points.

· A, B, C and D represent the commoning of conductors in the harness.

Mechanism Launch Lock Confirm (SVM-CB JA) Ground Test

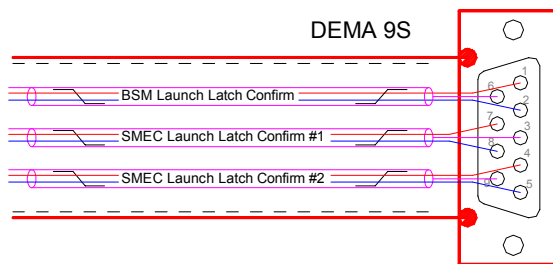

Mechanisms Launch Latch Confirm - JA RAL Ground Test

· 3 Insulated STPs

· No "Inner Shield" as defined in Section 4.2 is required on this tail.

· Harness connector is a Socket.

Note: The Ground Test harness uses the D-Sub connector indicated above however this connector type is not a requirement. The "flight" version of this harness is anticipated to be Mil 38999 11-35. The contact arrangement for this is indicated below.

Mechanism Launch Lock Confirm (SVM-CB JA) Flight

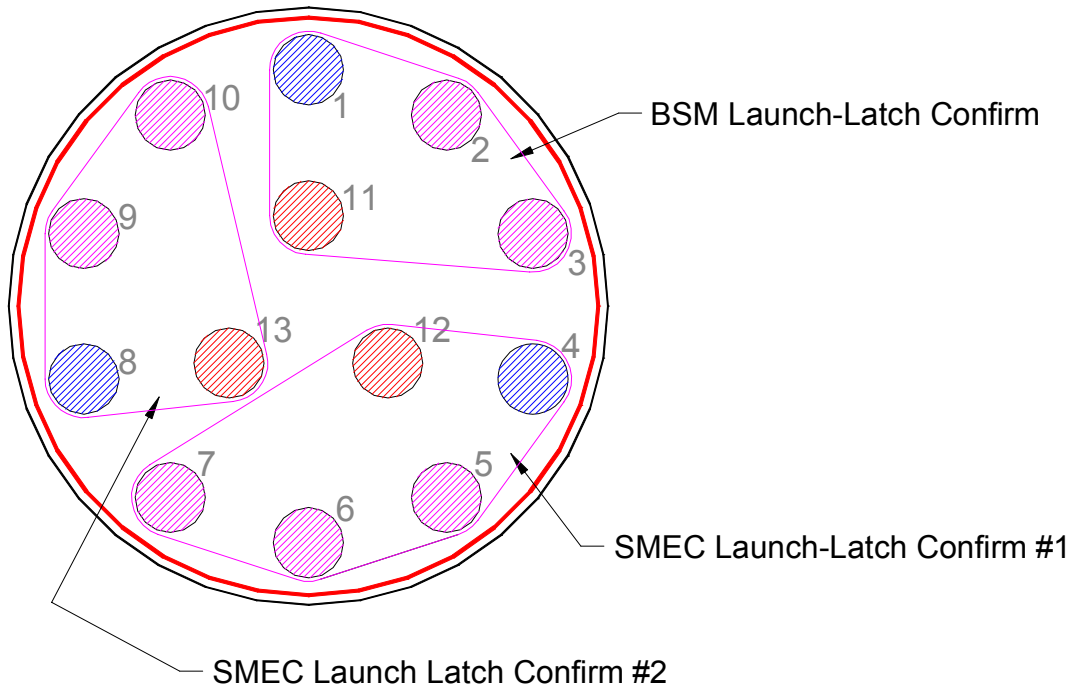

Mechanisms Launch Latch Confirm - PA RAL Ground Test

- 3 Insulated STPs
- No "Inner Shield" as defined in Section 4.2 is required on this tail.
- Harness "Overshield" as defined in Section 4.2 is 360° terminated to the EMC backshell
- Harness connector is a Socket.



SPIRE HARNESS DEFINITION DOCUMENT

Doc: SPIRE-RAL-PRJ-000608

Issue: 1.2

Date: 17/02/05

Page 91 of 245

SMEC Control (FCU P17)

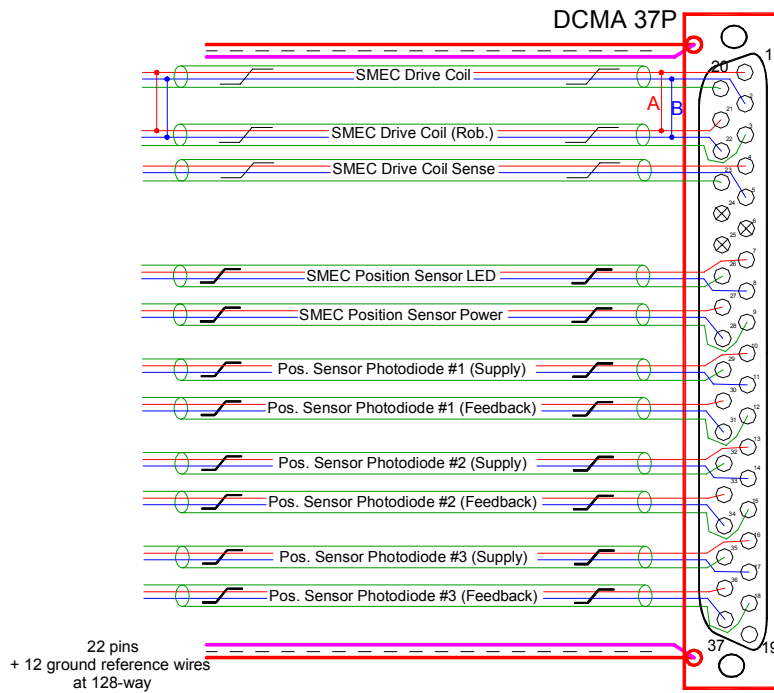

SMEC Control Tail FCU P17

- 11 STP
- 1 Single
- See Section 4.2 for details regarding the implementation of the shields.
- No harness bundle overall insulation baselined. May be added later by locally wrapping with insulation at contact points.
- A and B represent the commoning of conductors in the harness.

Thermometry C (FCU P21)

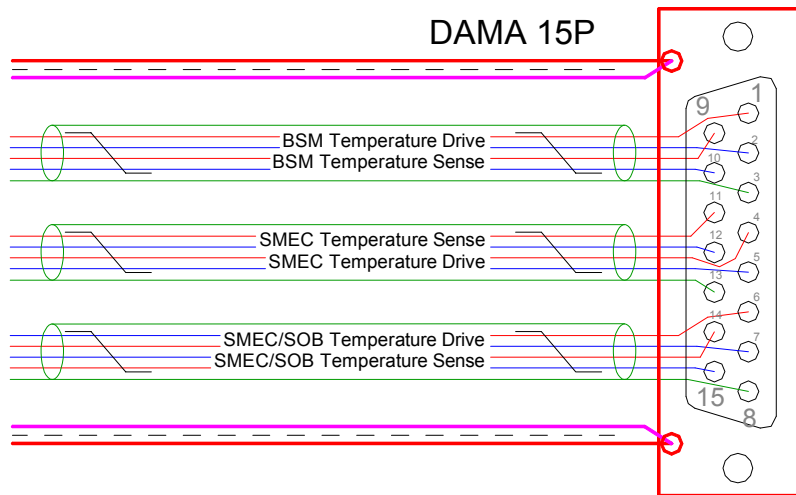

Thermometry Tail C (FCU P21/P22)

- Three STQ
- See Section 4.2 for details regarding the implementation of the shields.
- No harness bundle overall insulation baselined. May be added later by locally wrapping with insulation at contact points.



SPIRE HARNESS DEFINITION DOCUMENT

Doc: SPIRE-RAL-PRJ-000608

Issue: 1.2

Date: 17/02/05

Page 92 of 245

SVM-CB S11 128-Way Pin Allocation (View of wiring side of connector)

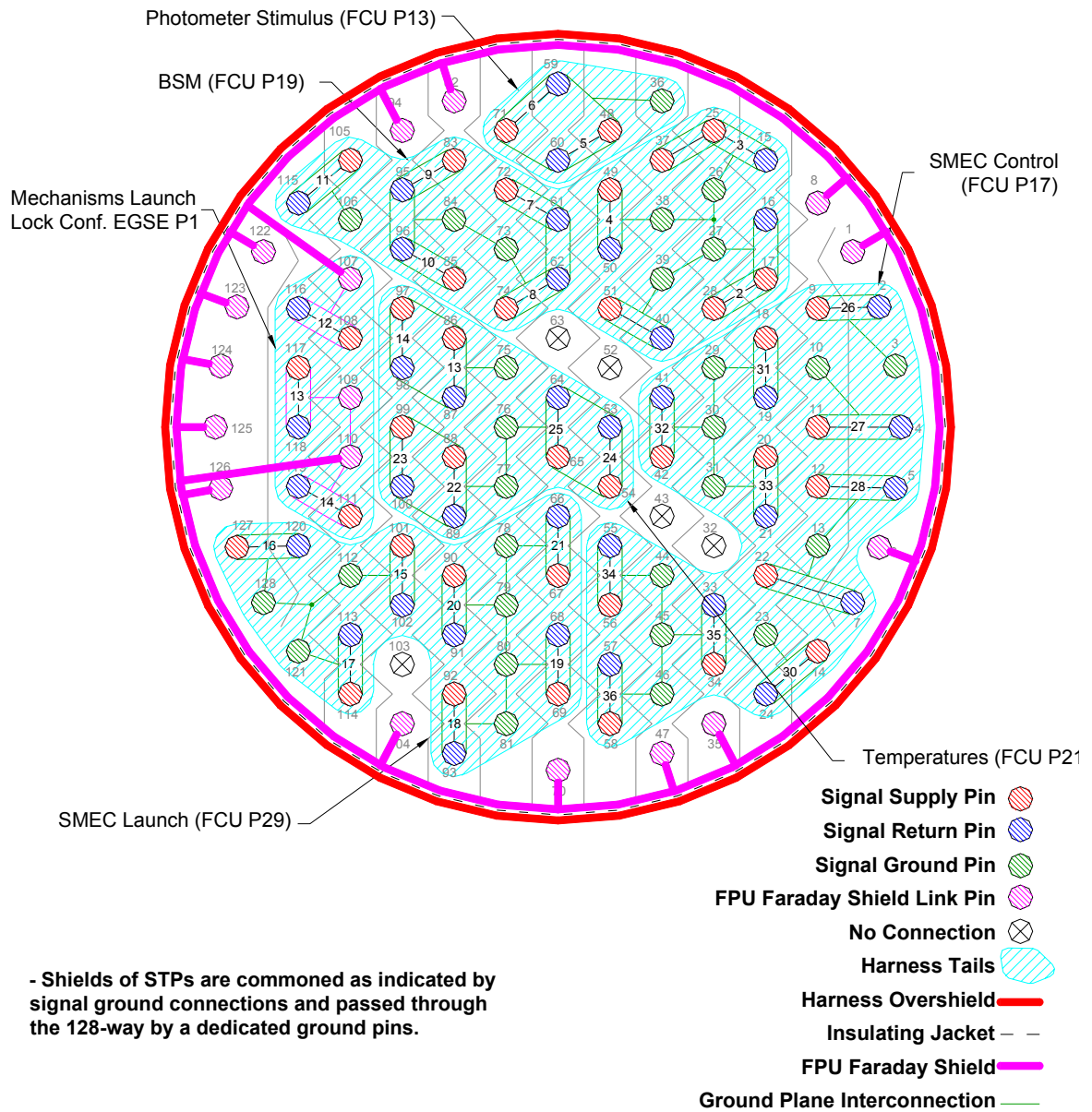



SPIRE HARNESS DEFINITION DOCUMENT

Doc: SPIRE-RAL-PRJ-000608

Issue: 1.2

Date: 17/02/05

Page 93 of 245

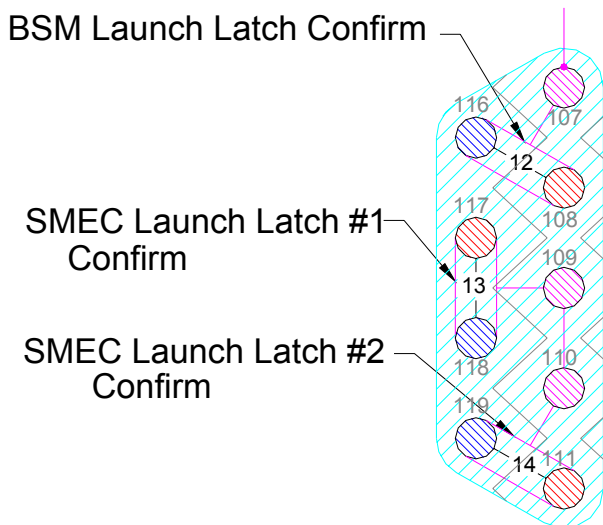
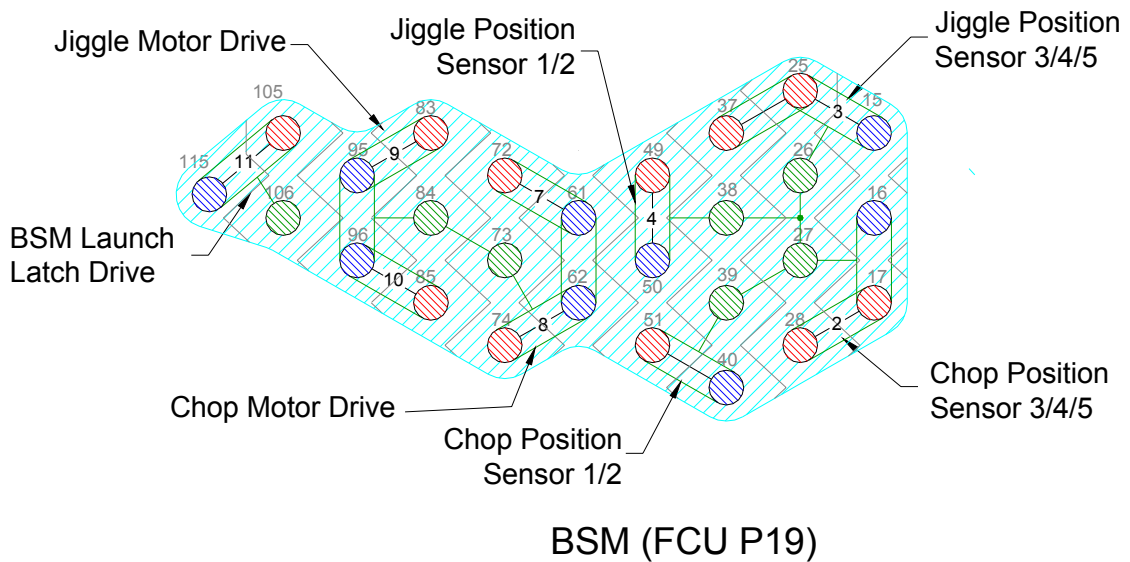
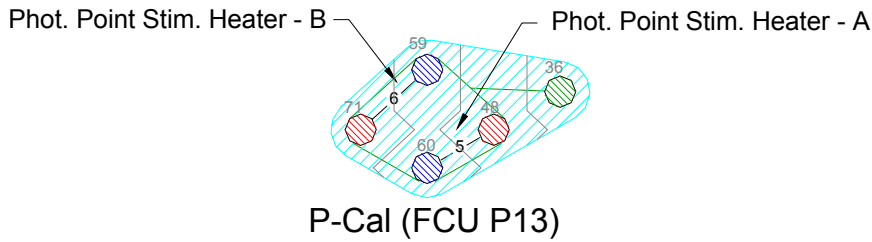

Mech. Launch Latch Confirm JA



SPIRE HARNESS DEFINITION DOCUMENT

Doc: SPIRE-RAL-PRJ-000608

Issue: 1.2

Date: 17/02/05

Page 94 of 245

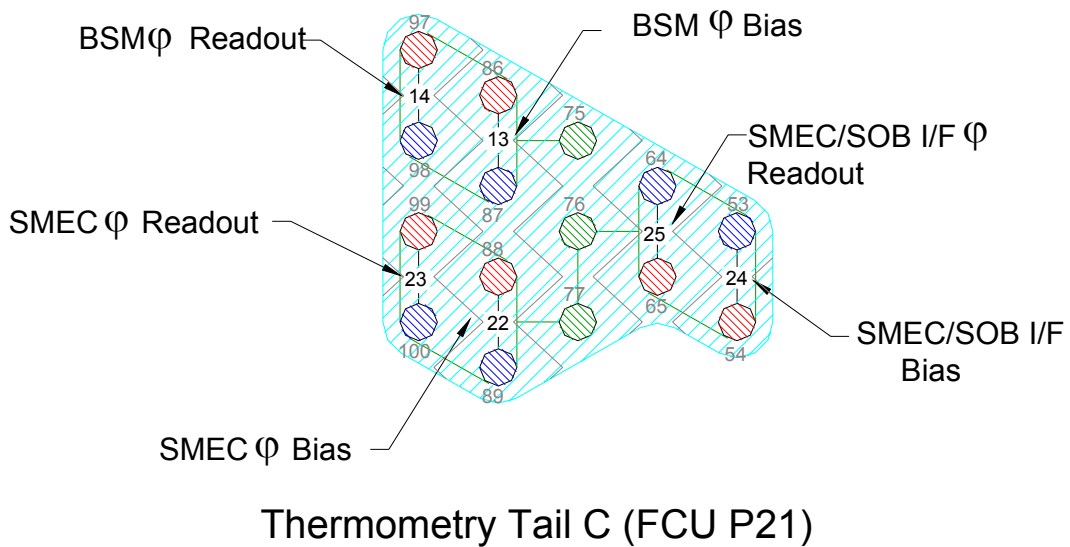
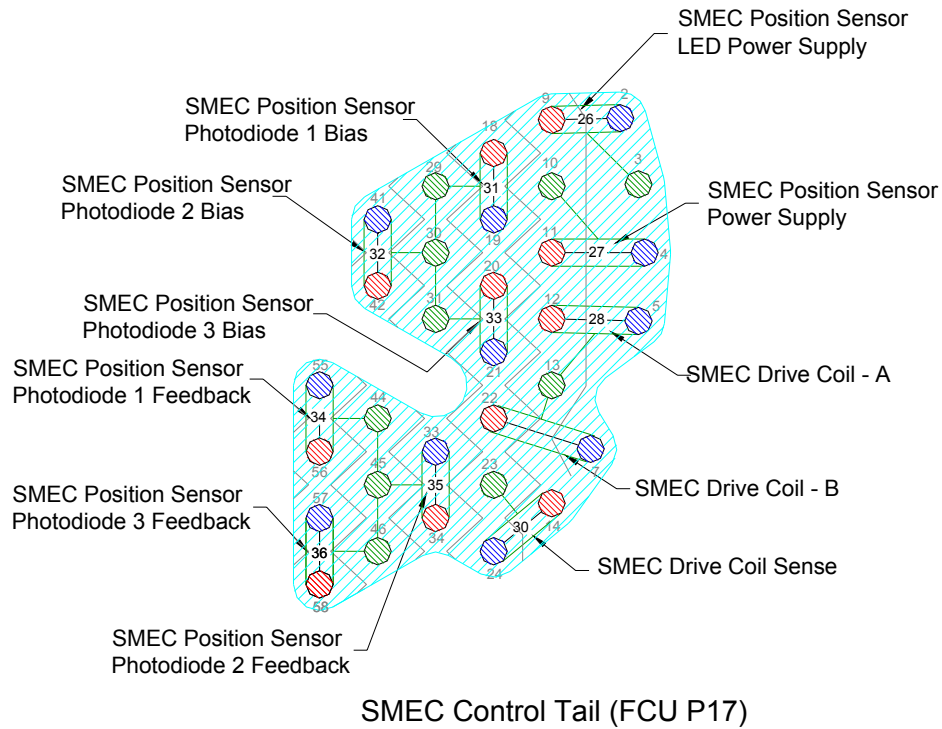



SPIRE HARNESS DEFINITION DOCUMENT

Doc: SPIRE-RAL-PRJ-000608

Issue: 1.2

Date: 17/02/05

Page 95 of 245

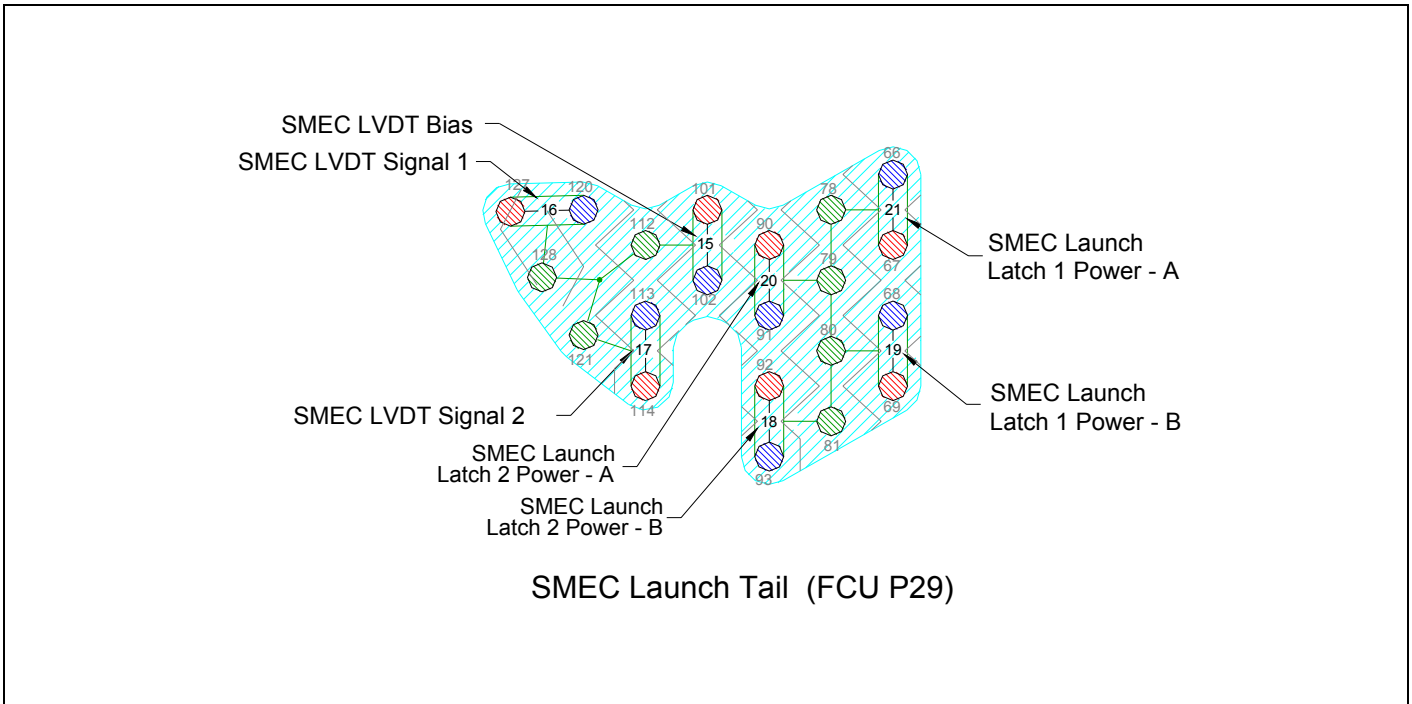

Table 4.2-13 - SIH-SS-11 Temperature Tail (P21) Listing

Function	Signal Name	15way P21	Max. current	Wire lay-up	Max Ohms	128Way #11
BSM temperature I+	T_BSMM_1_D+	1	1 μA	Insulated screened twisted quad	1000	86
BSM temperature V+	T_BSMM_1_S+	9	N/A		1000	97
BSM temperature V-	T_BSMM_1_S-	10	N/A		1000	98
BSM temperature I-	T_BSMM_1_D-	2	1 μA		1000	87
BSM temperature shld	T_BSMM_1_SHD	3	N/A		N/A	75
SMEC temperature I+	T_FTSM_1_D+	4	1 μA	Insulated screened twisted quad	1000	88
SMEC temperature V+	T_FTSM_1_S+	11	N/A		1000	99
SMEC temperature V-	T_FTSM_1_S-	12	N/A		1000	100
SMEC temperature I-	T_FTSM_1_D-	5	1 μA		1000	89
SMEC temperature shld	T_FTSM_1_SHD	13	N/A		N/A	77
SMEC/SOB I/F temperature I+	T_FTSS_1_D+	6	1 μA	Insulated screened twisted quad	1000	54
SMEC/SOB I/F temperature V+	T_FTSS_1_S+	14	N/A		1000	65
SMEC/SOB I/F temperature V-	T_FTSS_1_S-	15	N/A		1000	64
SMEC/SOB I/F temperature I-	T_FTSS_1_D-	7	1 μA		1000	53
SMEC/SOB I/F temperature shld	T_FTSS_1_SHD	8	N/A		N/A	76
	Harness Overshield	EMC Backshell				

Table 4.2-14 - SIH-SS-11 SMEC Control Tail (FCU P17) Listing

Function	Signal Name	37-Way P17	Max. Current	Wire Lay-up	Max Ohms	128Way #11
SMEC Drive Coil I+	S_Mot_Coil_P	1 (A)	100mA	Insulated screened twisted pair	5	12
SMEC Drive Coil I-	S_Mot_Coil_N	2 (B)	100mA		5	5
SMEC Drive Coil shld	S_Mot_Coil_Shld	20	N/A		N/A	13
SMEC Drive Coil (Rob) I+	S_Mot_Coil_P	21(A)	100mA	Insulated screened twisted pair	5	22
SMEC Drive Coil (Rob) I-	S_Mot_Coil_N	22 (B)	100mA		5	7
SMEC Drive Coil (Rob) shld	S_Mot_Coil_Shld	3	N/A		N/A	13
SMEC Drive Coil Sense+	S_Mot_Bemf_P	4	10 μ A	Insulated screened twisted pair	500	14
SMEC Drive Coil Sense-	S_Mot_Bemf_N	5	10 μ A		500	24
SMEC Drive Coil shld	S_Mot_Bemf_Shld	23	N/A		N/A	23
SMEC position sensor Led power supply	LEDA	7	1mA	Insulated screened twisted pair	100	9
SMEC position sensor Led power return	LEDC	8	1mA		100	2
SMEC position sensor Led power Shield	LED_Shld	26	N/A		N/A	3
SMEC position sensor power supply	+3V	27	1mA	Insulated screened twisted pair	100	11
SMEC position sensor power return	-3V	28	1mA		100	4
SMEC position sensor power Shield	POS_POWER_Shld	9	N/A		N/A	10
SMEC position sensor photodiode #1 I+	IPD1A	10	20 μ A	Insulated screened twisted pair	1000	18
SMEC position sensor photodiode #1 I-	IPD1C	11	20 μ A		1000	19
SMEC position sensor photodiode Shield	IPD1_SHD	29	N/A		N/A	29
SMEC pos. sensor photodiode #1 feedback +	CRPD1A	30	10 μ A	Insulated screened twisted pair	1000	56
SMEC pos. sensor photodiode #1 feedback -	CRPD1C	31	10 μ A		1000	55
SMEC pos. sensor photodiode feedback Shld	CRPD1_SHD	12	N/A		N/A	44
SMEC position sensor photodiode #2 I+	IPD2A	13	20 μ A	Insulated screened twisted pair	1000	42
SMEC position sensor photodiode #2 I-	IPD2C	14	20 μ A		1000	41
SMEC position sensor photodiode Shield	IPD2_Shld	32	N/A		N/A	30
SMEC pos. sensor photodiode #2 feedback +	CRPD2A	33	10 μ A	Insulated screened twisted pair	1000	34
SMEC pos. sensor photodiode #2 feedback -	CRPD2C	34	10 μ A		1000	33
SMEC pos. sensor photodiode feedback Shld	CRPD2_Shld	15	N/A		N/A	45
SMEC position sensor photodiode #3 I+	IPD3A	16	20 μ A	Insulated screened twisted pair	1000	20
SMEC position sensor photodiode #3 I-	IPD3C	17	20 μ A		1000	21
SMEC position sensor photodiode Shield	IPD3_Shld	35	N/A		N/A	31
SMEC pos. sensor photodiode #3 feedback +	CRPD3A	36	10 μ A	Insulated screened twisted pair	1000	58
SMEC pos. sensor photodiode #3 feedback -	CRPD3C	37	10 μ A		1000	57
SMEC pos. sensor photodiode feedback Shld	CRPD3_Shld	18	N/A		N/A	46
Harness Overshield		EMC Backshell				

Table 4.2-15 - SIH-SS-11 Photometer Stimulus Heater P13 Listing

Function	P13	Max. Current	Wire Lay-up	MaxOhms	128Way #11
Photometer Point Stim. Heater I+ _A	2	7 mA	Screened twisted quad	10	48
Photometer Point Stim.Heater V+ _B	3	7 mA		10	71
Photometer Point Stim.Heater I- _A	7	7 mA		10	60
Photometer Point Stim.Heater V- _B	8	7 mA		10	59
Screen	4				36
Harness Overshield		EMC Backshell			

4 pins used

Table 4.2-16 SIH-SS-11 SMEC Launch Tail (FCU P29) Listing

Function	Signal Name	37-Way P29	Max. Current	Wire lay-up	Max Ohms	128Way #11
SMEC launch latch #1 power supply A	S_LL#1_Coil_P	1	400 mA / 50ms	Insulated screened twisted pair	5	67
SMEC launch latch #1 power return A	S_LL#1_Coil_N	2	400 mA / 50ms		5	66
SMEC launch latch #1 power Shield A	S_LL#1_Coil_Shld	20	N/A		N/A	78
SMEC launch latch #1 power supply B		21	400 mA / 50ms	Insulated screened twisted pair	5	69
SMEC launch latch #1 power return B		22	400 mA / 50ms		5	68
SMEC launch latch #1 power Shield B		3	N/A		N/A	80
SMEC launch latch #2 power supply A		4	400 mA / 50ms	Insulated screened twisted pair	5	90
SMEC launch latch #2 power return A		5	400 mA / 50ms		5	91
SMEC launch latch #2 power Shield A		23	N/A		N/A	79
SMEC launch latch #2 power supply B	S_LL#2_Coil_P	24	400 mA / 50ms	Insulated screened twisted pair	5	92
SMEC launch latch #2 power return B	S_LL#2_Coil_N	25	400 mA / 50ms		5	93
SMEC launch latch #2 power Shield B	S_LL#2_Coil_Shld	6	N/A		N/A	81
SMEC LVDT primary coil power supply (P)	LVDT_PRIM_P	13	5 mA	Insulated screened twisted pair	5	101
SMEC LVDT primary coil power supply (N)	LVDT_PRIM_N	14	5 mA		5	102
SMEC LVDT primary coil power supply Shld	LVDT_PRIM_Shld	32	N/A		N/A	112
SMEC LVDT secondary coil # 1 signal (P)	LVDT_SECA_P	15	50 μ A	Insulated screened twisted pair	5	127
SMEC LVDT secondary coil # 1 signal (N)	LVDT_SECA_N	16	50 μ A		5	120
SMEC LVDT secondary coil # 1 signal Shield	LVDT_SECA_Shld	34	N/A		N/A	128
SMEC LVDT secondary coil # 2 signal (P)	LVDT_SECB_P	17	50 μ A	Insulated screened twisted pair	5	114
SMEC LVDT secondary coil # 2 signal (N)	LVDT_SECB_N	18	50 μ A		5	113
SMEC LVDT secondary coil # 2 signal Shield	LVDT_SECB_Shld	36	N/A		N/A	121
Harness Overshield		EMC Backshell				

Table 4.2-17 - SIH-SS-11 BSM Tail (FCU P19) Listing

Function		37way P19	Max. Current	Wire Lay-up	Max Ohms	128Way #11
Chop Position Sensor 1	Ch_Sens_Sup	1	1 mA	Insulated screened twisted pair	1000	51
Chop Position Sensor 2	Ch_Sens_Rtn	20	1 mA		1000	40
Chop Position Sensor shld1	Ch_Sens_Shld1	22 (A)	N/A		N/A	39 (A)
Chop Position Sensor 3	Ch_Sens_Sup_Meas	2	250 nA	Insulated screened twisted triple	1000	28
Chop Position Sensor 4	Ch_Sens_O/P	21	N/A		1000	17
Chop Position Sensor 5	Ch_Sens_Rtn_Meas	3	N/A		1000	16
Chop Position Sensor shld2=A	Ch_Sens_Shld1	22 (A)	N/A		N/A	27 (A)
Jiggle Position Sensor 1	Jig_Sens_Sup	4	1 mA	Insulated screened twisted pair	1000	49
Jiggle Position Sensor 2	Jig_Sens_Ret	23	1 mA		1000	50
Jiggle Position Sensor shld1	Ch_Sens_Shld1	22 (A)	N/A		N/A	38 (A)
Jiggle Position Sensor 3	Jig_Sens_Sup_Meas	5	250 nA	Insulated screened twisted triple	1000	15
Jiggle Position Sensor 4	Jig_Sens_O/P	24	N/A		1000	25
Jiggle Position Sensor 5	Jig_Sens_Rtn_Meas	6	N/A		1000	37
Jiggle Position Sensor shld2=B	Ch_Sens_Shld1	22 (A)	N/A		N/A	26 (A)
BSM Launch latch drive +	B_LL_Sup	13	35mA	Insulated screened twisted pair	10	105
BSM Launch latch drive -	B_LL_Rtn	14	35mA		10	115
BSM Launch latch drive shld	LL_Shld	33	N/A		N/A	106
Chop Motor Drive 1	Ch_Mot_Sup	15	40 mA	Insulated screened twisted quad	10	72
Chop Motor Drive 2	Ch_Mot_Rtn	34	40 mA		10	61
Chop Motor Drive 3	Ch_Bemf_Meas_P	16	40 mA		10	62
Chop Motor Drive 4	Ch_Bemf_Meas_N	35	40 mA		10	74
Chop Motor Drive shld	Ch_Mot_Shld	17 (B)	N/A		N/A	73 (B)
Jiggle Motor Drive 1	Jig_Mot_Sup	36	40 mA	Insulated screened twisted quad	10	83
Jiggle Motor Drive 2	Jig_Mot_Rtn	18	40 mA		10	95
Jiggle Motor Drive 3	Jig_Bemf_Meas_P	37	40 mA		10	96
Jiggle Motor Drive 4	Jig_Bemf_Meas_N	19	40 mA		10	85
Jiggle Motor Drive shld	Ch_Mot_Shld	17 (B)	N/A		N/A	84 (B)
Harness Overshield		EMC Backshell				

Mechanism Launch Latch Confirm: SVM-CB JA

Table 4.2-18 SIH-SS-11 Mechanism Launch Latch Confirm: SVM-CB JA Listing

Function	JA RAL Ground Test	JA Flight	Max. Current	Wire Lay-up	128Way #11
BSM Launch Latch Confirm +	1	11	1 mA	Insulated screened twisted pair	108
BSM Launch Latch Confirm -	2	1	1 mA		116
BSM Launch Latch Conf. Shield (connected to BSM Chassis in FPU)	6	2 and 3	N/A		107
SMEC Launch Latch #1 Confirm +	7	12	1 mA	Insulated screened twisted pair	117
SMEC Launch Latch #1 Confirm -	8	4	1 mA		118
SMEC Launch Latch #1 Confirm Shield (connected to SMEC Chassis in FPU)	3	5, 6 and 7	N/A		109 (A)
SMEC Launch Latch #2 Confirm +	4	13	1mA	Insulated screened twisted pair	111
SMEC Launch Latch #2 Confirm -	5	8	1mA		119
SMEC Launch Latch #2 Confirm Shield (connected to SMEC Chassis in FPU)	9	9 and 10	N/A		110 (A)

FPU Faraday Shield Link Pins (C11, I11 and S11)								
1	6	8	35	47	70	82	94	104
107	109	110	122	123	124	125	126	X



SPIRE HARNESS DEFINITION DOCUMENT

Doc: SPIRE-RAL-PRJ-000608
 Issue: 1.2
 Date: 17/02/05
 Page 100 of 245

4.2.12 S12 SVM-CB 12 – DCU AUX-R

Overall Mechanical Drawing

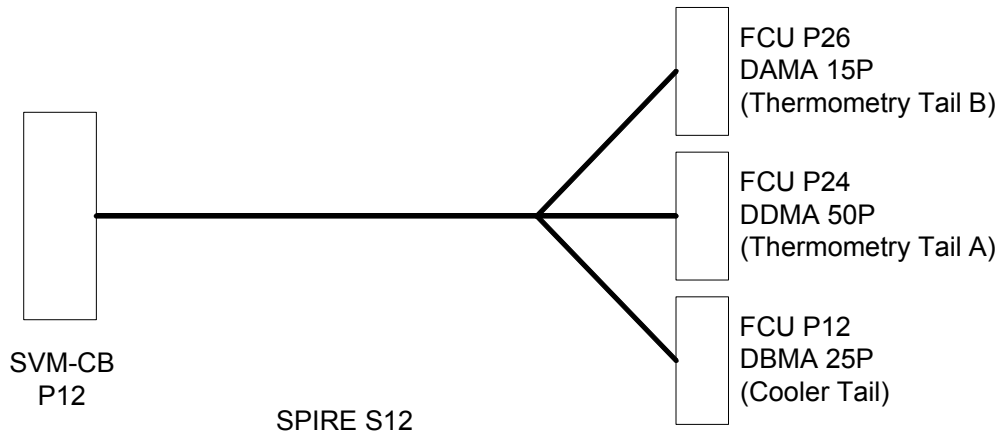

Redundant version of I10, and the same as it

Connector/Backshell Details

Prime side harness

DBMA25P + Glenair 559 - E - 359 - M - 3 to	FCUJ12	Heater Tail (Red)
DDMA50P + Glenair 559 - E - 359 - M - 5 to	FCUJ24	FPU Thermometry Tail A (Red.)
DAMA 15P + Glenair 559 - E - 359 - M - 2 to	FCUJ26	FPU Thermometry Tail B (Red.)

Harness Layup

As I10



SPIRE HARNESS DEFINITION DOCUMENT

Doc: SPIRE-RAL-PRJ-000608
Issue: 1.2
Date: 17/02/05
Page 101 of 245

4.2.13 S13 SVM-CB 13 – DCU DRV-R

Overall Mechanical Drawing

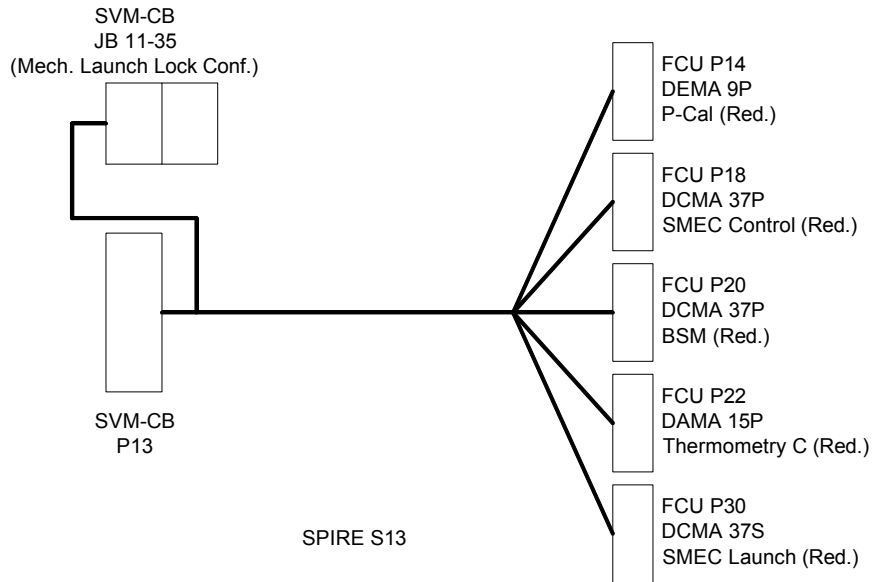

Format as I11

Connector/Backshell Details

Redundant Side

DEMA 9 P+	Glenair	557 - T-357 - M - 1	to	FCUJ14	P-Cal (Red.)
DCMA37P+	Glenair	557 - E-359 - M - 4	to	FCUJ18	SMEC Control Module (Red.)
DCMA37P+	Glenair	557 - E-359 - M - 4	to	FCUJ20	BSM Module (Red.)
DAMA15P+	Glenair	557 - E-359 - M - 2	to	FCUJ22	Thermometry Tail C (Red.)
DCMA37S+	Glenair	557 - T-357 - M - 4	to	FCUJ30	SMEC Launch (Red.)
MS27497T 12F35P + EMI Backshell			to	(PB) Mechanisms Launch Lock Conf.	(Red.)

Harness Layup

As I11.

Contact Details

As I11

4.3 Intermediate Harnesses

- **Conductor wire**

The impedance requirements for these harnesses are specified in §

- **SVM Harness Shielding**

These harnesses make the thermal jump between the SVM connector panel and the CVV wall. An implementation that is compatible with the requirements RD 2 is illustrated in Figure 4-2. (c.f.§4.2and §4.4)

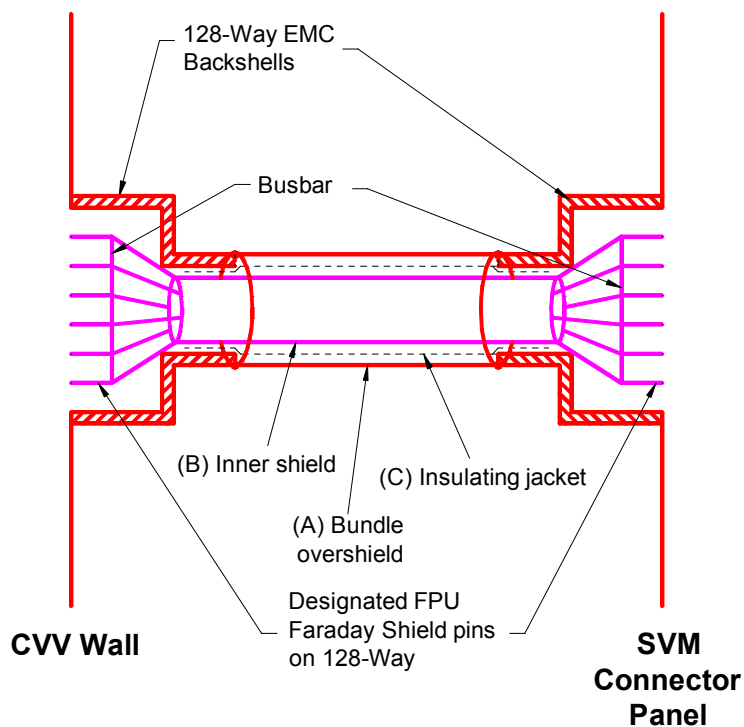
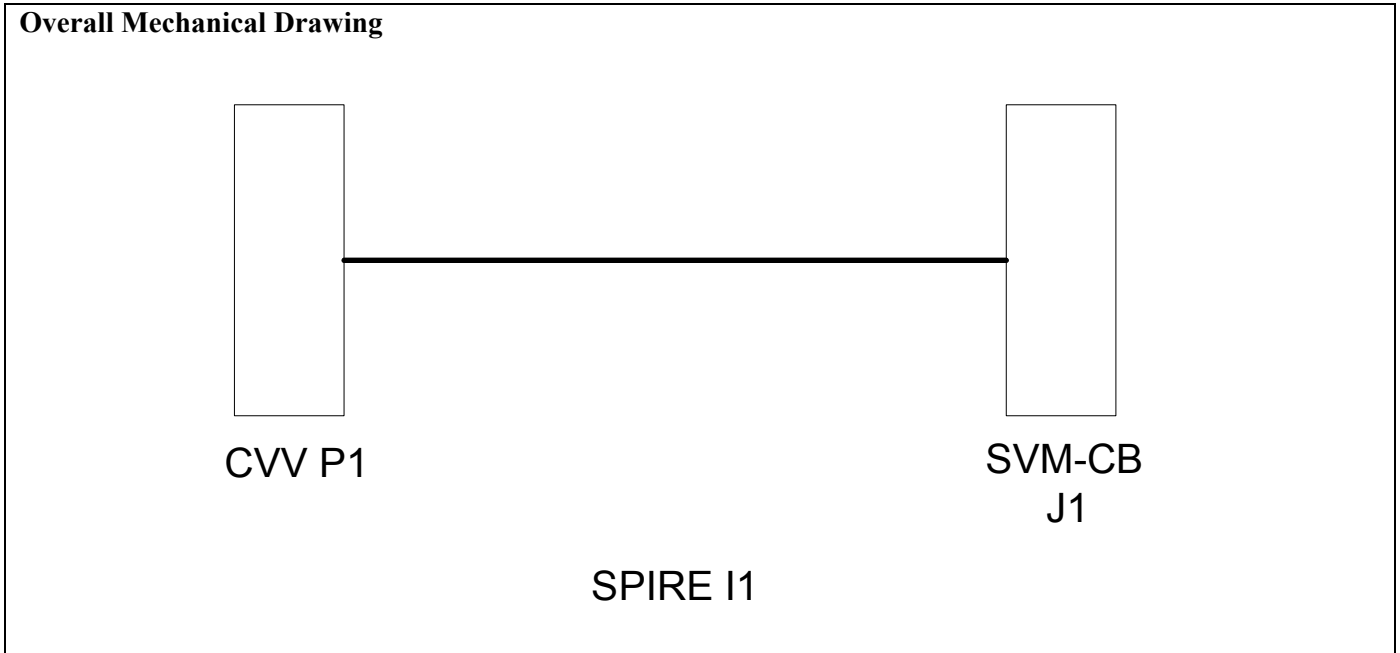

Figure 4-2

4.3.1 I1 SVM-CB 1 – CVV1



Connector/Backshell Details
 128-Way connectors at either end + TBD EMC Backshells.

Harness Layup
 As per S1 – SVM Panel end

Contact Details
 As per 128-way connector on S1

4.3.2 I2 SVM-CB 2 – CVV2

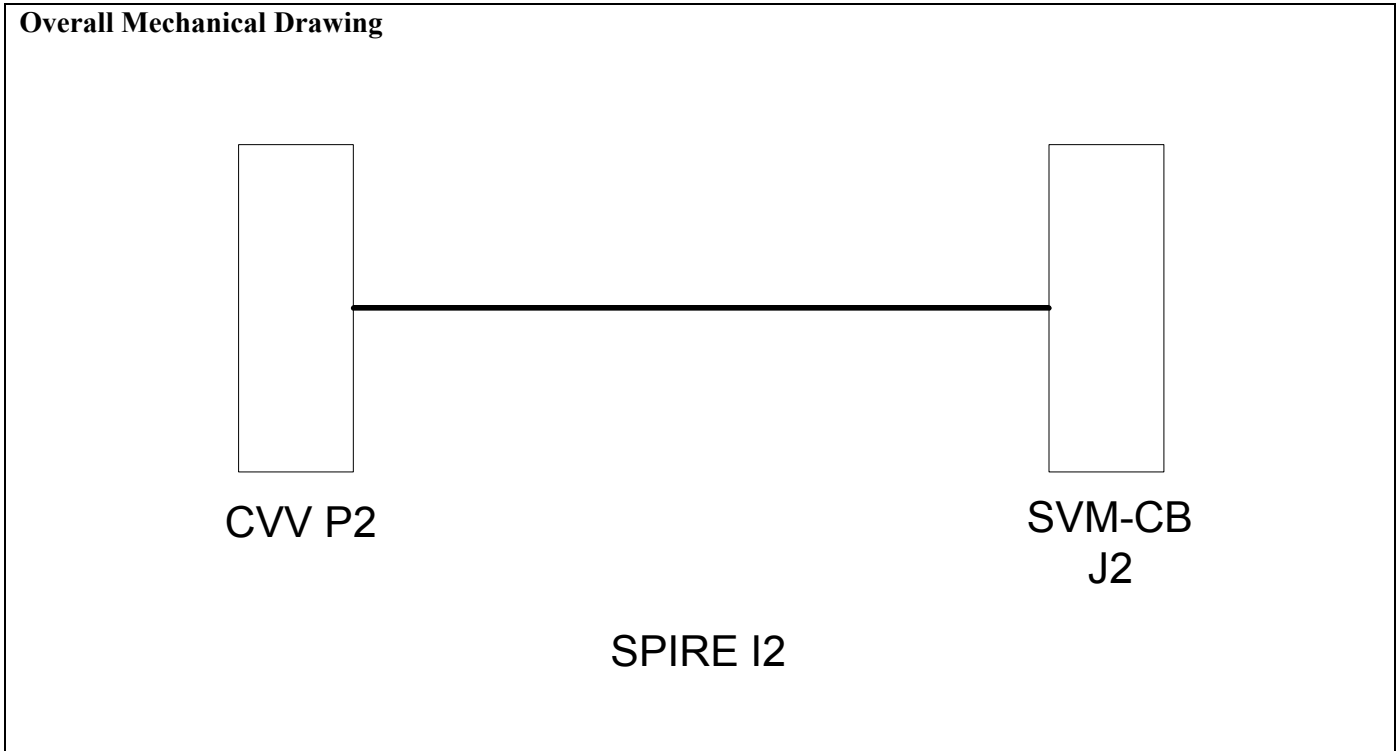

Connector/Backshell Details
 128-Way connectors at either end + TBD EMC Backshells.

Harness Layup
 As per S2

Contact Details
 As per 128-way connector on S2

4.3.3 I3 SVM-CB 3 – CVV 3

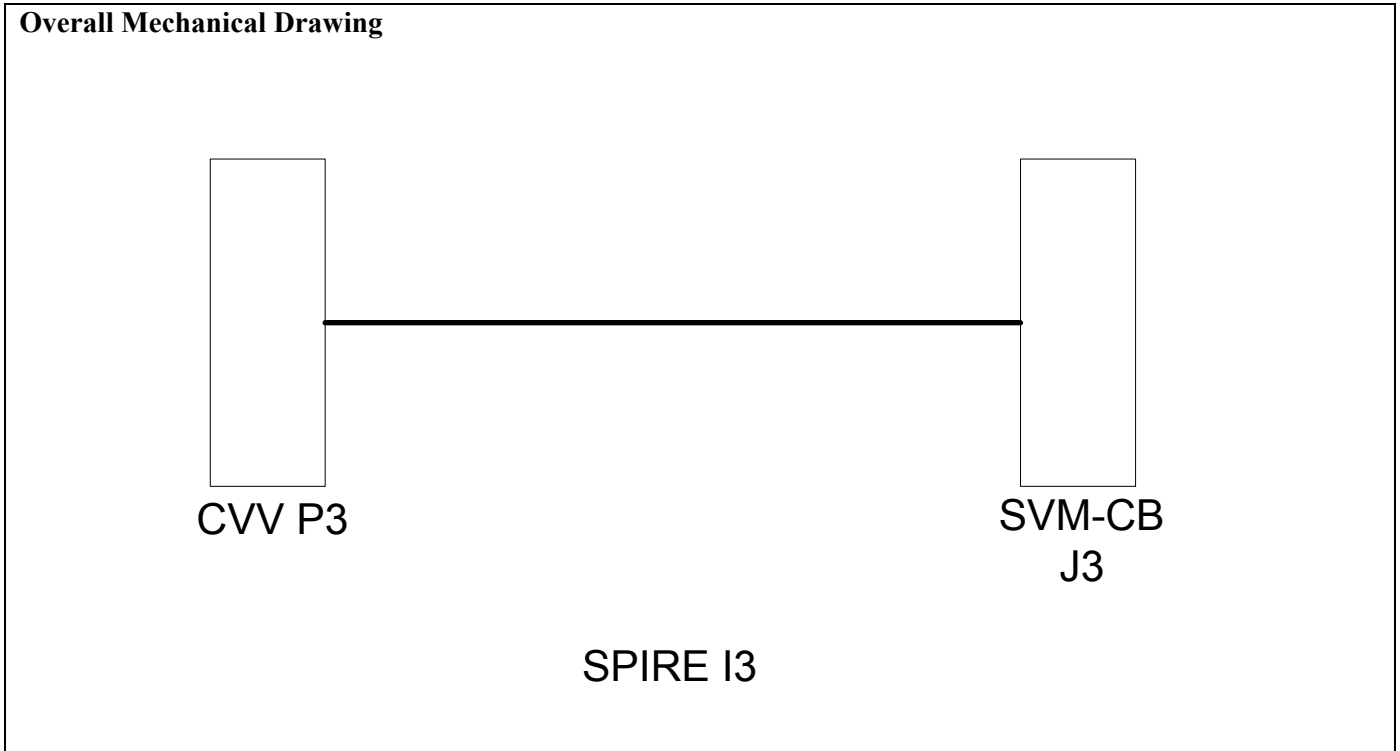

Connector/Backshell Details
 128-Way connectors at either end + TBD EMC Backshells.

Harness Layup
 As per S3

Contact Details
 As per 128-way connector on S3

4.3.4 I4 SVM-CB 4 – CVV 4

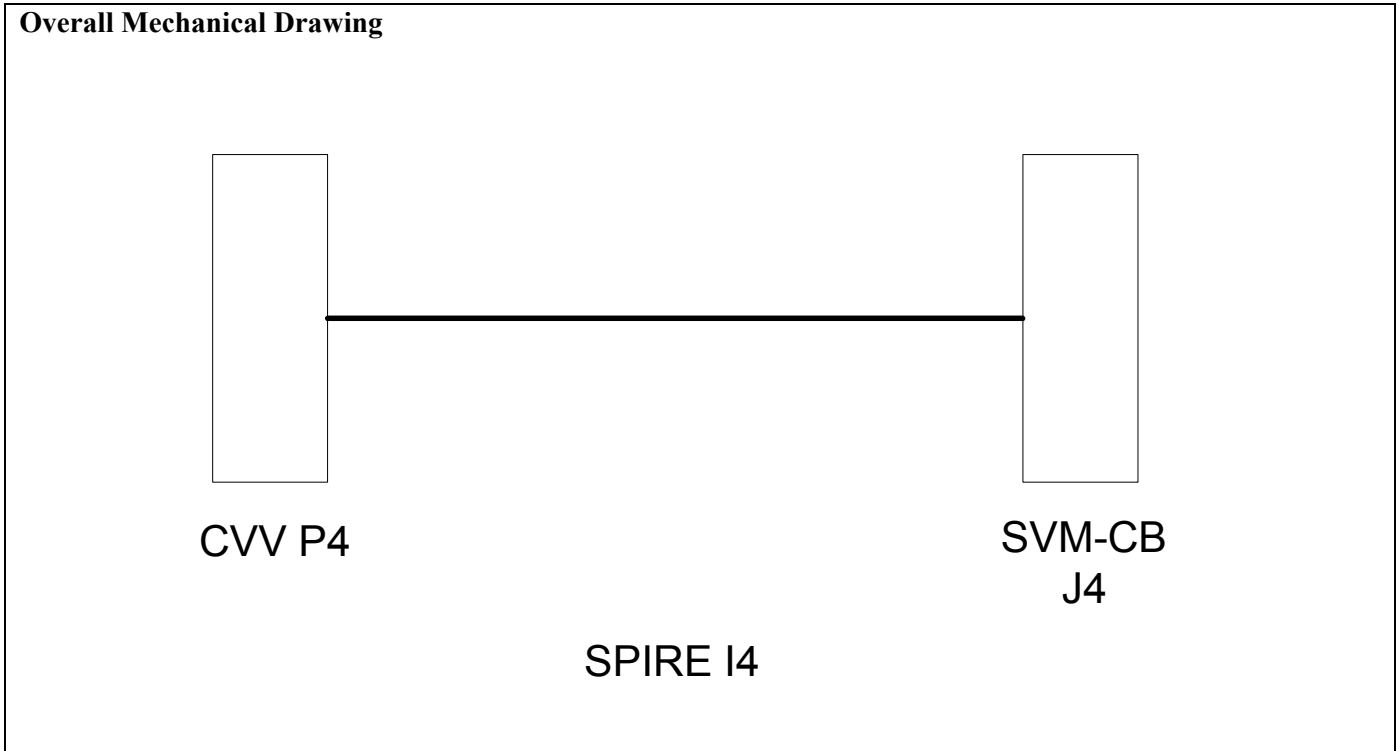

Connector/Backshell Details
 128-Way connectors at either end + TBD EMC Backshells.

Harness Layup
 As per S4

Contact Details
 As per 128-way connector on S4

4.3.5 I5 SVM-CB 5 – CVV 5

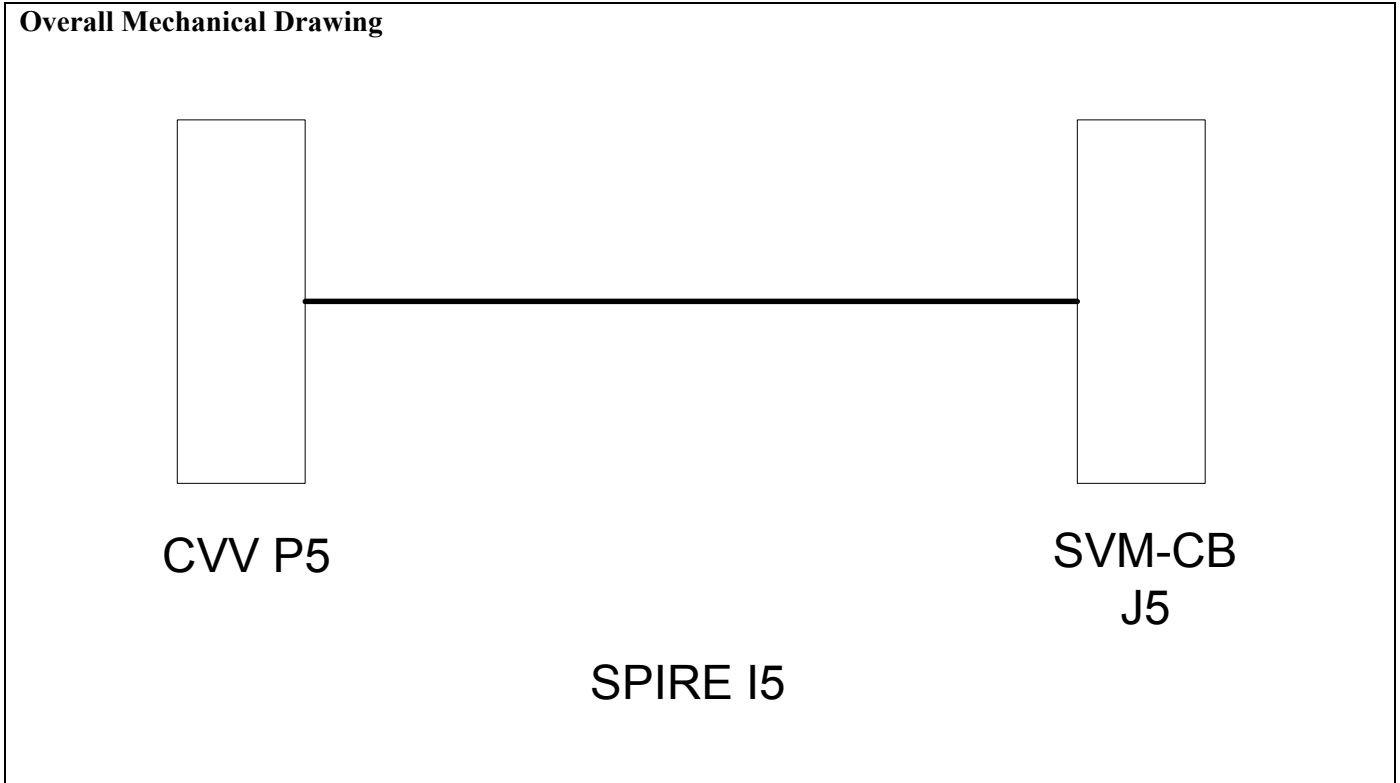

Connector/Backshell Details
 128-Way connectors at either end + TBD EMC Backshells.

Harness Layup
 As per S5

Contact Details
 As per 128-way connector on S5

4.3.6 I6 SVM-CB 6 – CVV 6

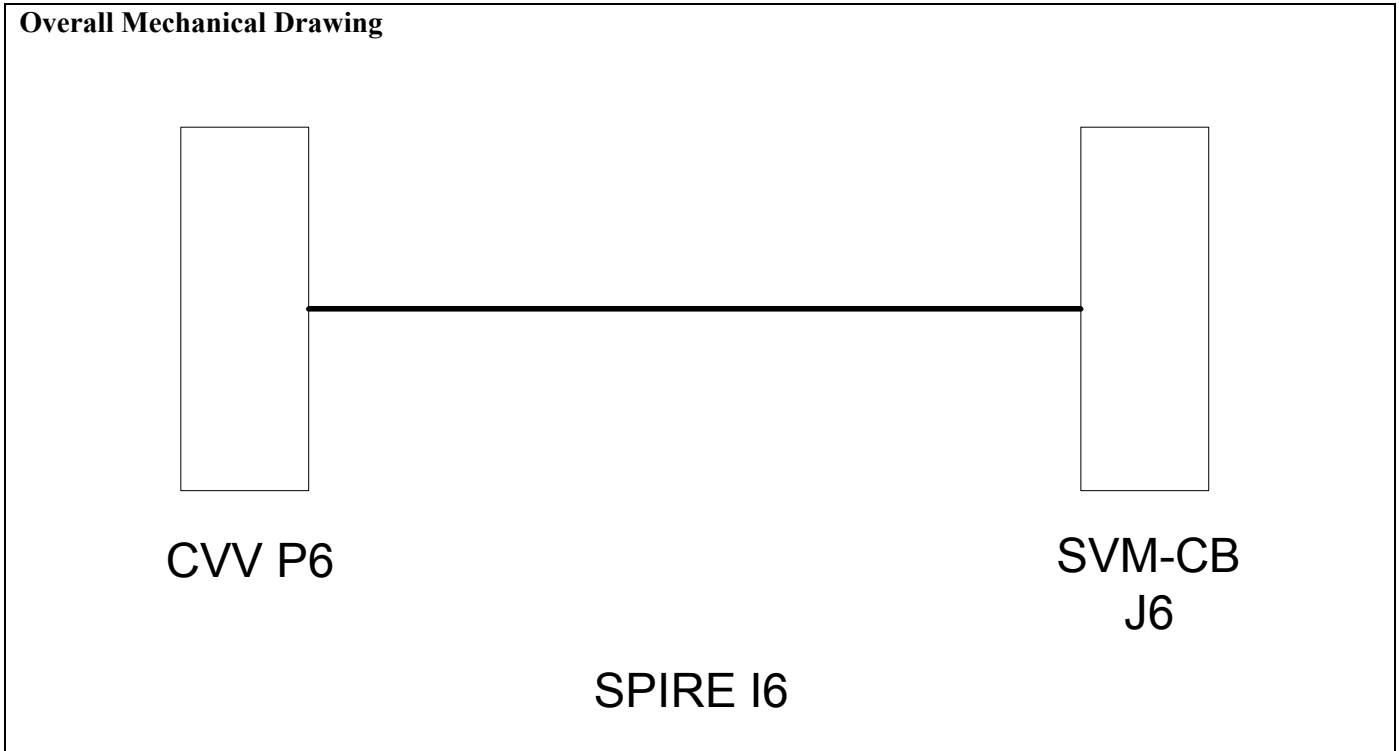

Connector/Backshell Details
 128-Way connectors at either end + TBD EMC Backshells.

Harness Layup
 As per S6

Contact Details
 As per 128-way connector on S6

4.3.7 I7 SVM-CB 7 – CVV 7

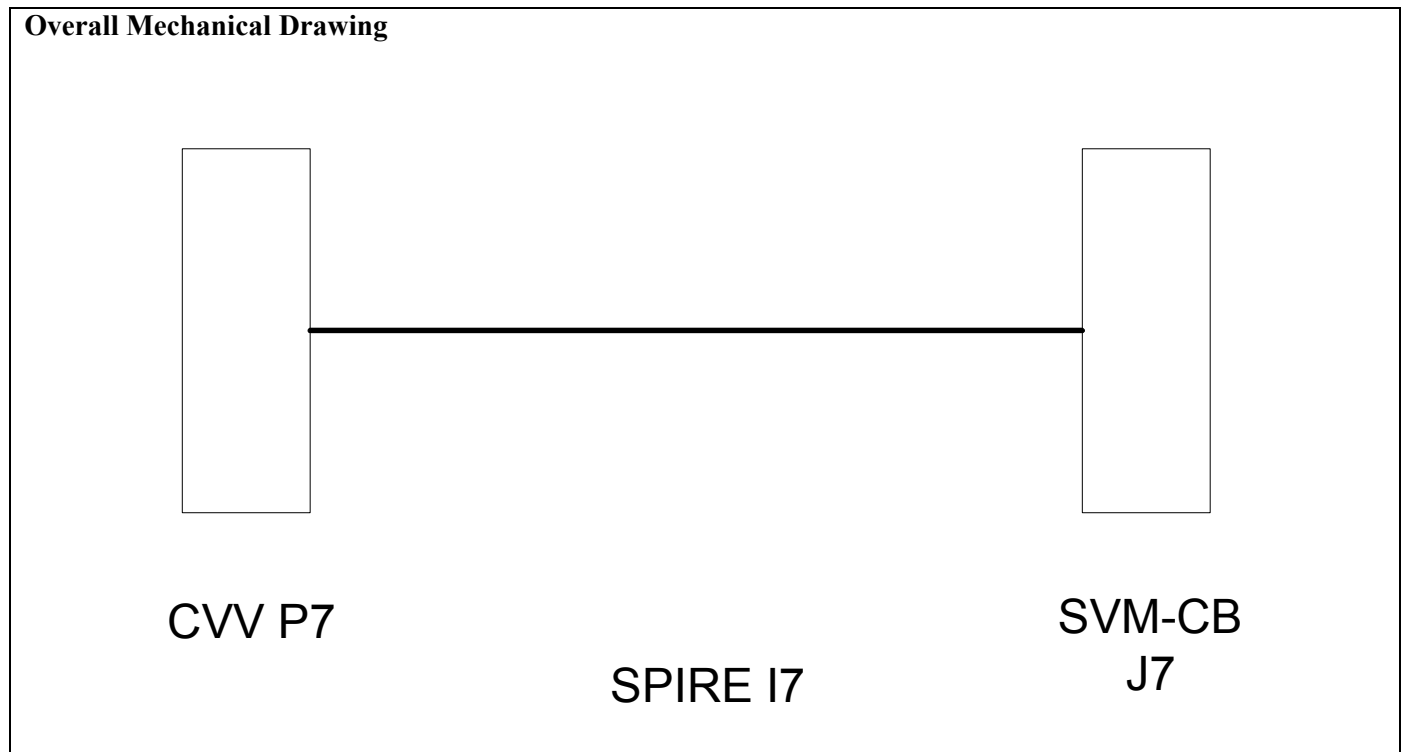

Connector/Backshell Details
 128-Way connectors at either end + TBD EMC Backshells.

Harness Layup
 As per S7

Contact Details
 As per 128-way connector on S7

4.3.8 I8 SVM-CB 8 – CVV 8

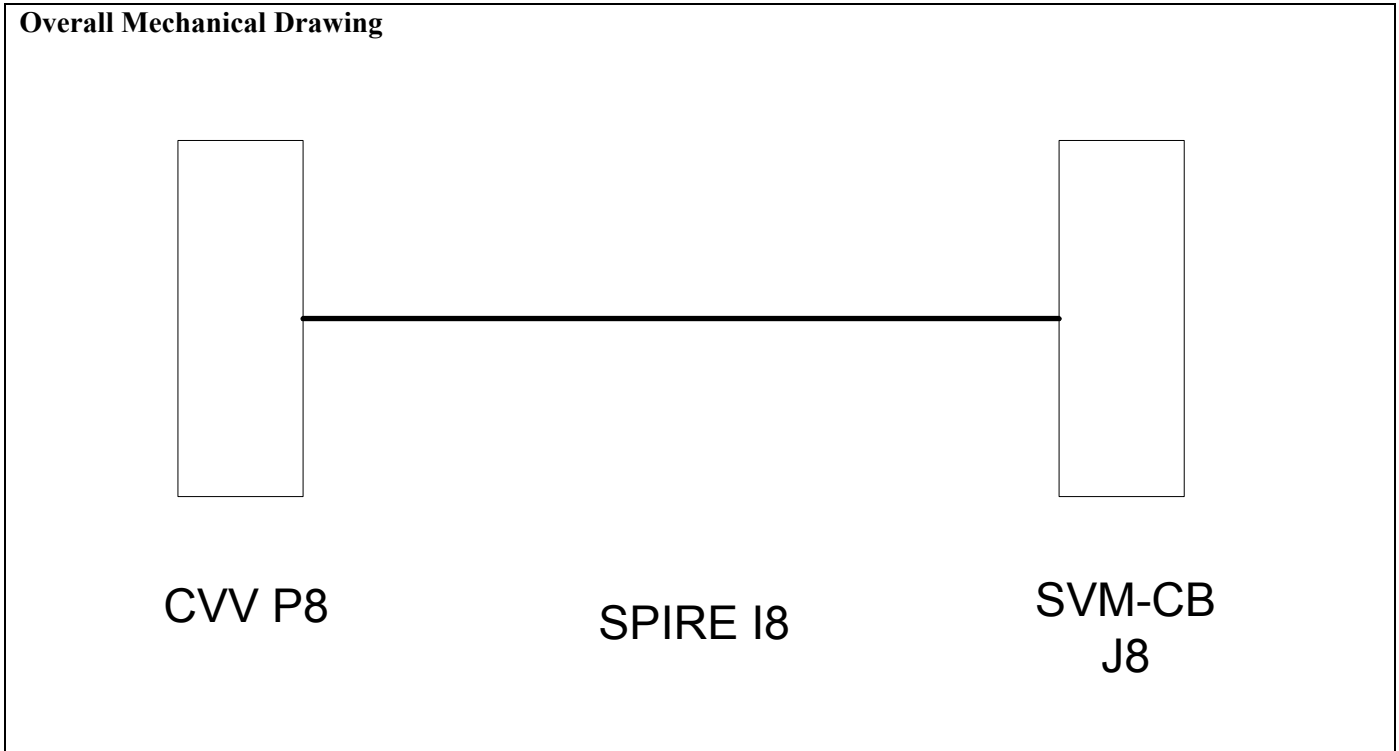

Connector/Backshell Details
 128-Way connectors at either end + TBD EMC Backshells.

Harness Layup
 As per S9

Contact Details
 As per 128-way connector on S9

4.3.9 I9 SVM-CB 9 – CVV 9

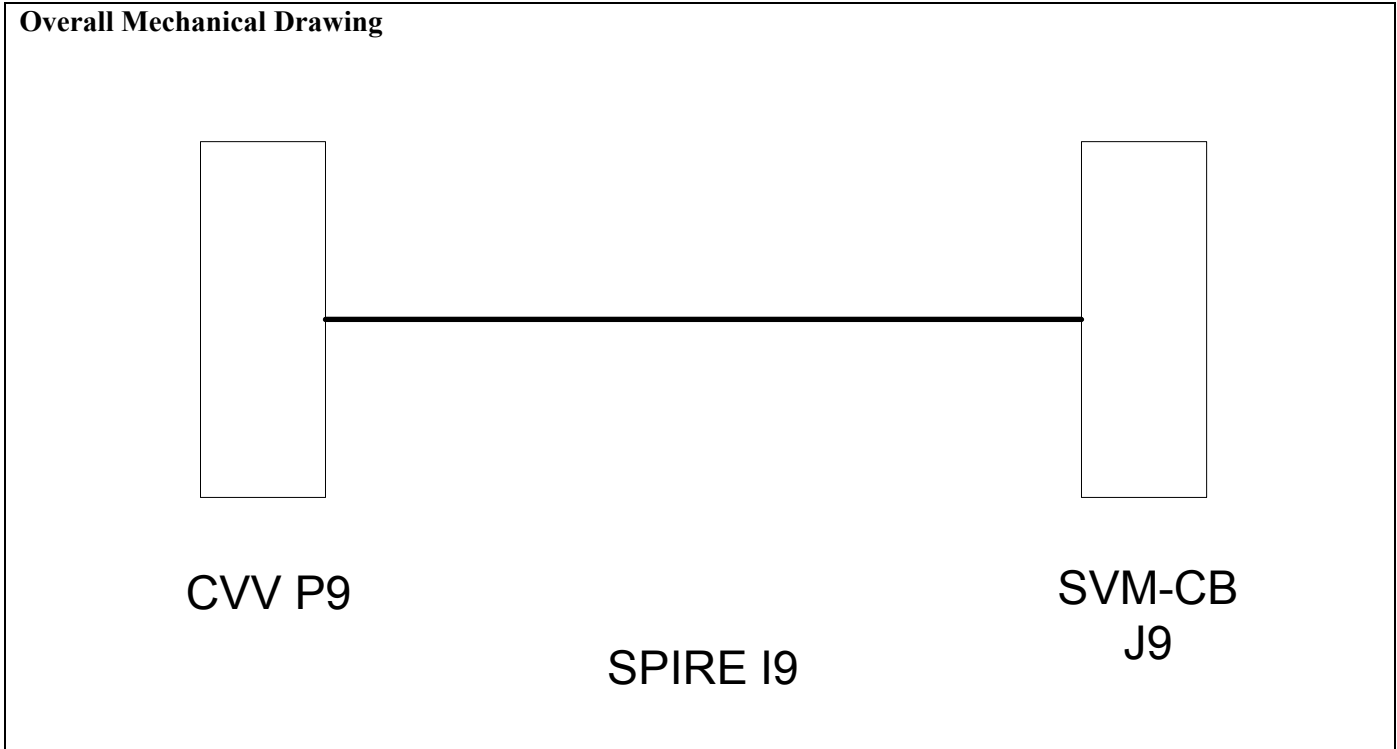

Connector/Backshell Details
 128-Way connectors at either end + TBD EMC Backshells.

Harness Layup
 As per S9

Contact Details
 As per 128-way connector on S9

4.3.10 I10 SVM-CB 10 – CVV 10

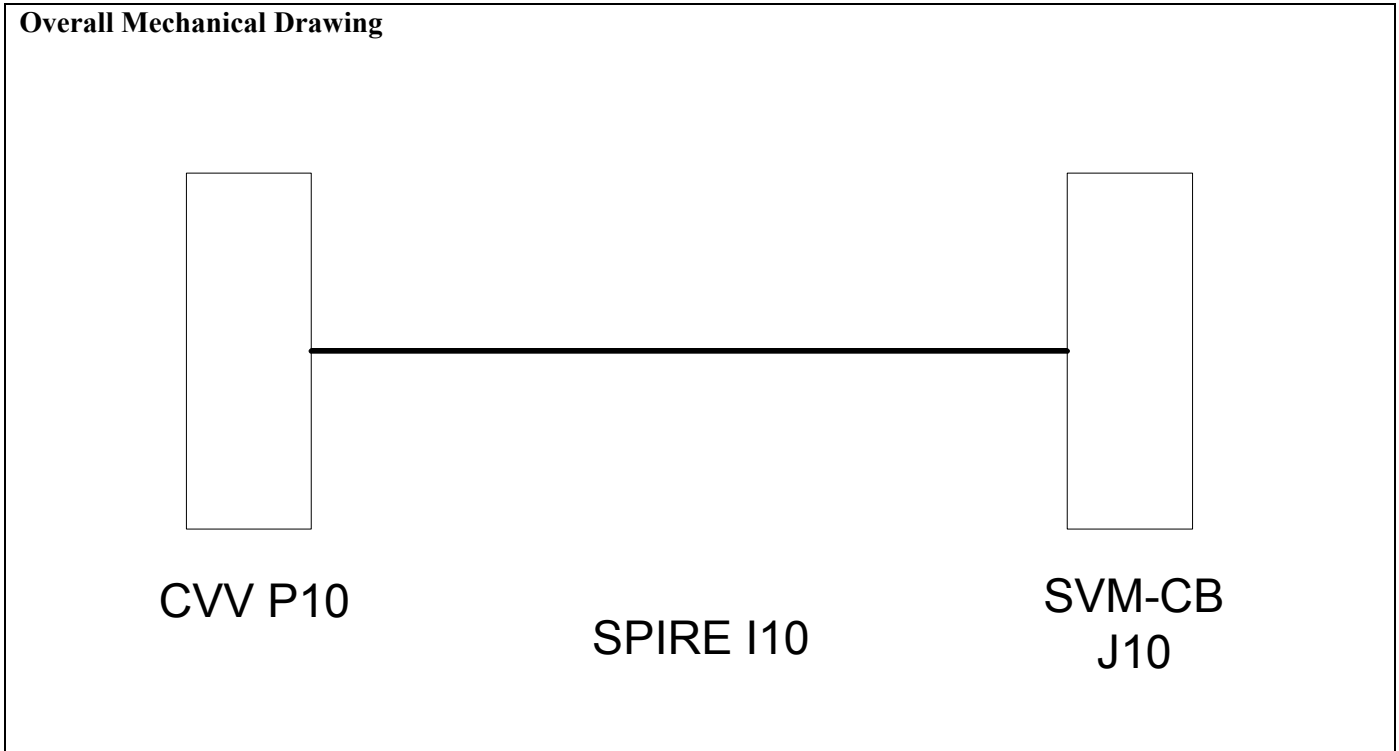

Connector/Backshell Details

128-Way connectors at either end + TBD EMC Backshells.

Harness Layup

As per S10

Contact Details

As per 128-way connector on S10

4.3.11 I11 SVM-CB 11 – CVV 11

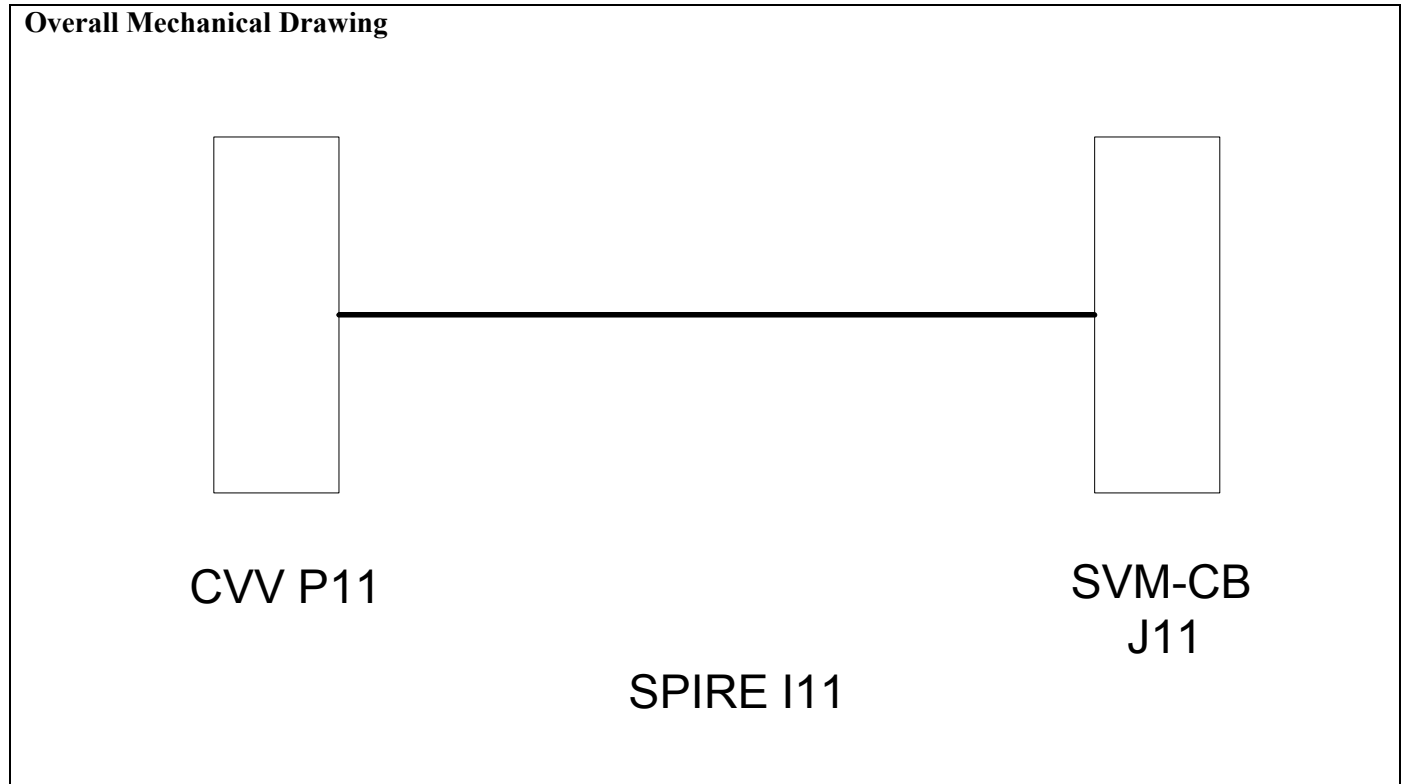

Connector/Backshell Details
128-Way connectors at either end + TBD EMC Backshells.

Harness Layup
As per S11

Contact Details
As per 128-way connector on S11

4.3.12 I12 SVM-CB 12 – CVV 12

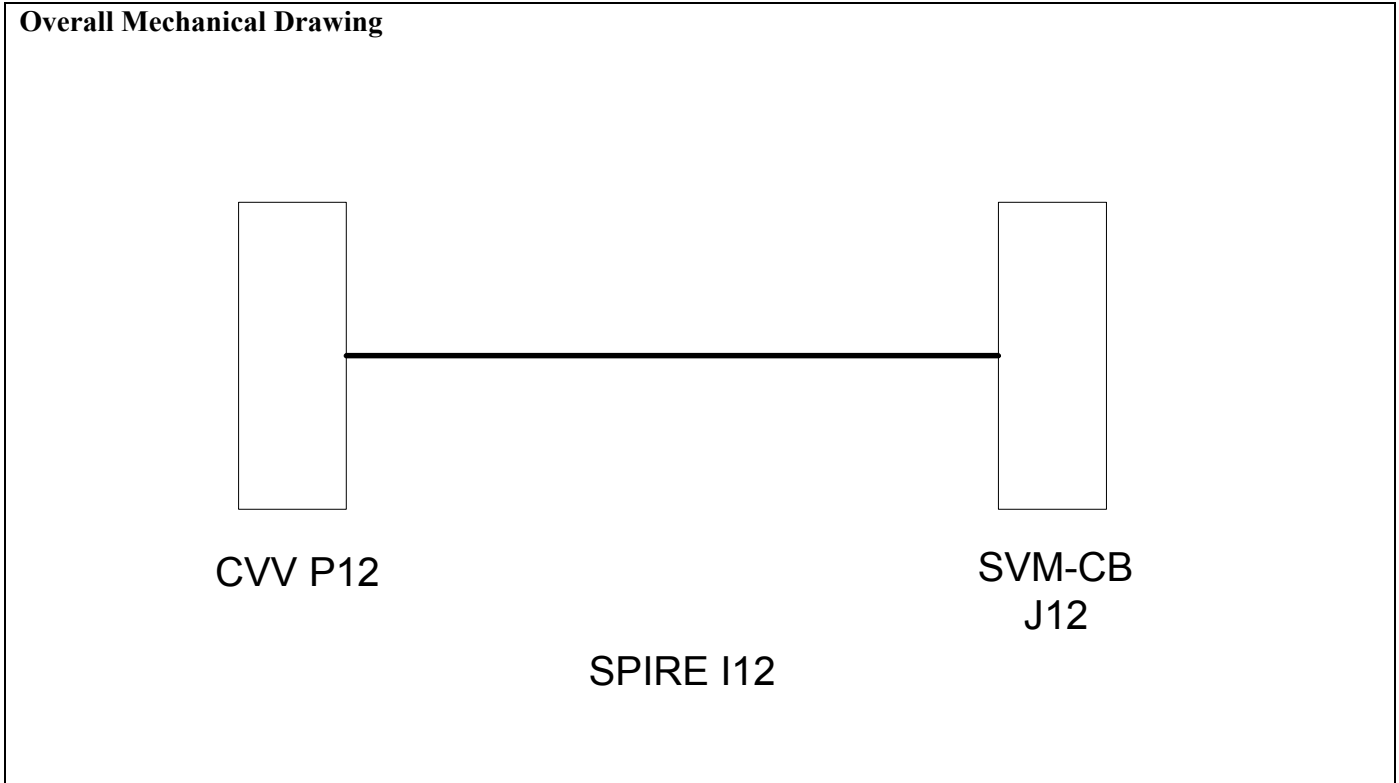

Connector/Backshell Details
As per I10

Harness Layup
As per S10

Contact Details
As per S10

4.3.13 I13 SVM-CB 13 – CVV 13

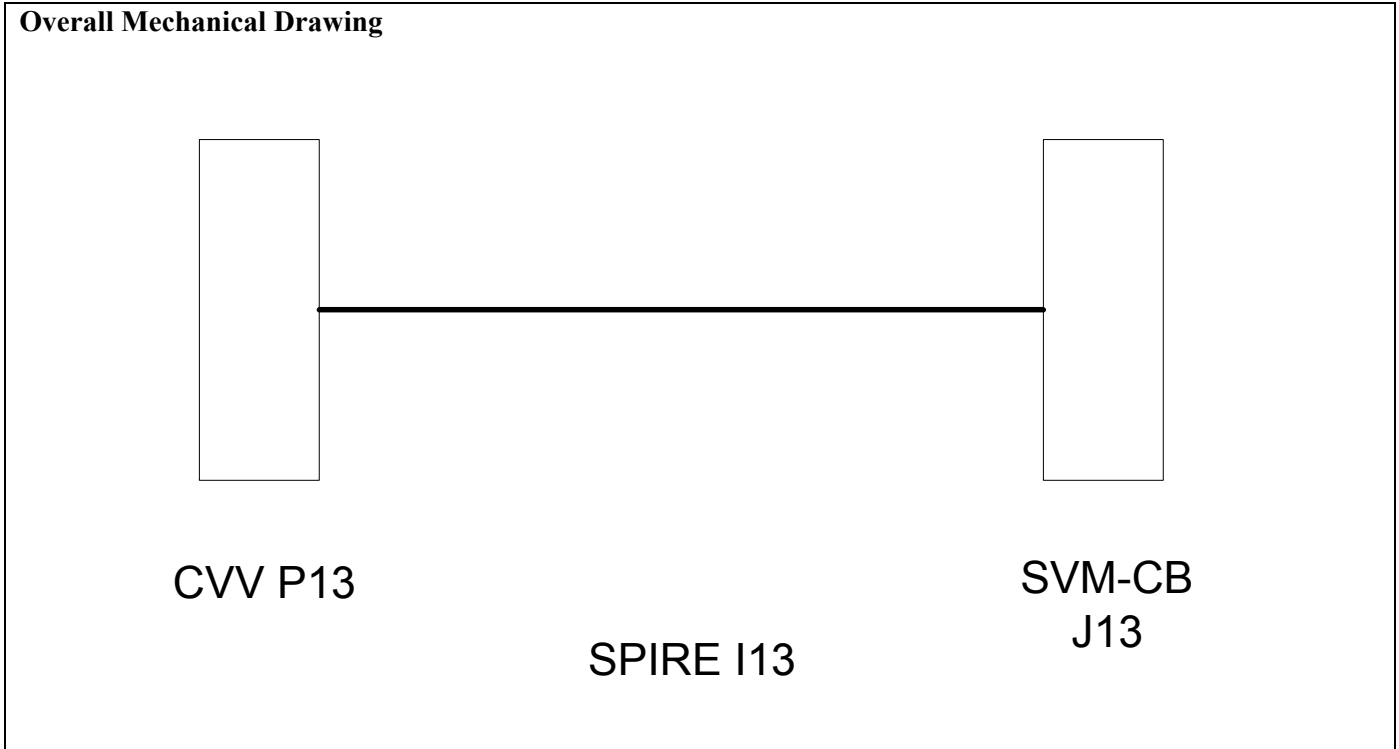

Connector/Backshell Details
As per S11

Harness Layup
As per S11

Contact Details
As per S11

4.4 Cryogenic Harnesses

The bundle overshield is isolated from the chassis of the spacecraft. At the wall of the CVV, the shield is terminated on designated pins on the 128-Way connectors. The shields are 360° terminated on EMC backshells on the cold units. (See §4.2, 4.3 and Figure 4-3)

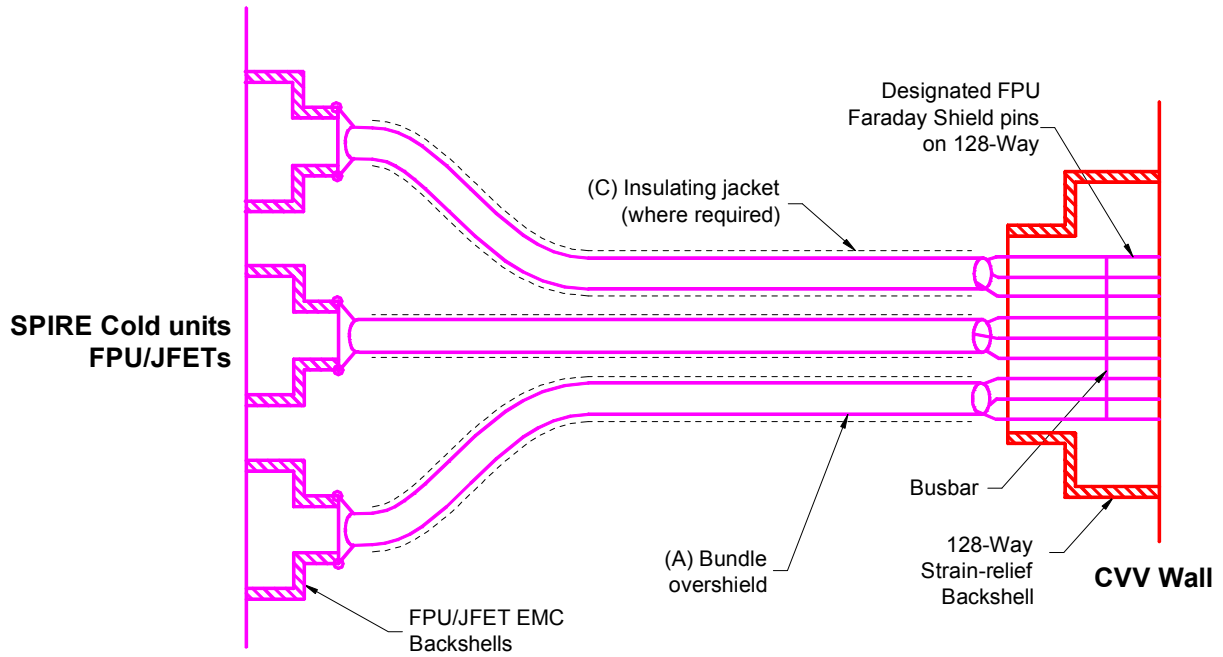

Figure 4-3



SPIRE HARNESS DEFINITION DOCUMENT

Doc: SPIRE-RAL-PRJ-000608
Issue: 1.2
Date: 17/02/05
Page 117 of 245

4.4.1 C1 CVV1 to HSJFS Type3

Overall Mechanical Drawing

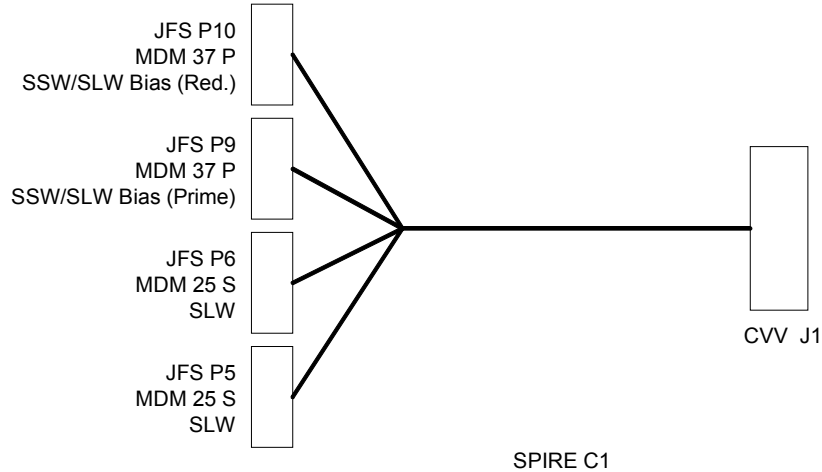

Connector/Backshell Details:

MDM 25 S	+	Glenair 507	-	T	-	196	-	M	-	25	to	JFSJ5	SLW JFET
MDM 25 S	+	Glenair 507	-	T	-	196	-	M	-	25	to	JFSJ6	SLW JFET
MDM 37 P	+	Glenair 507	-	T	-	196	-	M	-	37	to	JFSJ9	Spect. Bias
MDM 37 P	+	Glenair 507	-	T	-	196	-	M	-	37	to	JFSJ10	Spect. Bias

Harness Layout

Two 25way JFET bolometer tails, each as those in C4.
Two 37 way Spectrometer JFET Filter tails, each as follows:

Type 3 Bias Tails JFS P9/P10

- 13 Insulated STPs
- 3 Single insulated ground wires
- Note SLW and SSW Ground Separation
- See Section 4.3 for details regarding the implementation of the shields.
- The dotted lines indicate insulation jacket covering the overshield. Only required at clamp points but could cover entire length of harness.
- A, B, C and D represent the commoning of ground references within the connectors which pass through the 128-way CVV connector on single individual pins.
- Harness connector is a **Plug**. Drawing indicates pin allocation as seen from the rear, non-engaging face of the connector.

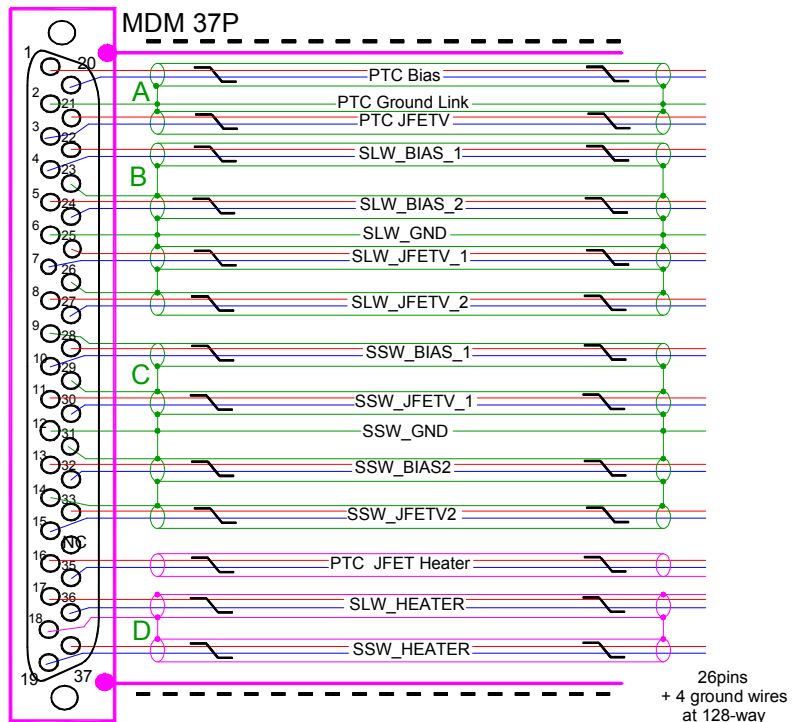

Because the small SLW has no subgroups that might fail, EACH of the JFET backharness leads are double-wired in this cryoharness, requiring links across in the filters.



SPIRE HARNESS DEFINITION DOCUMENT

Doc: SPIRE-RAL-PRJ-000608
 Issue: 1.2
 Date: 17/02/05
 Page 118 of 245

CVV C1 128-Way Pin Allocations (View of wiring side of connector)

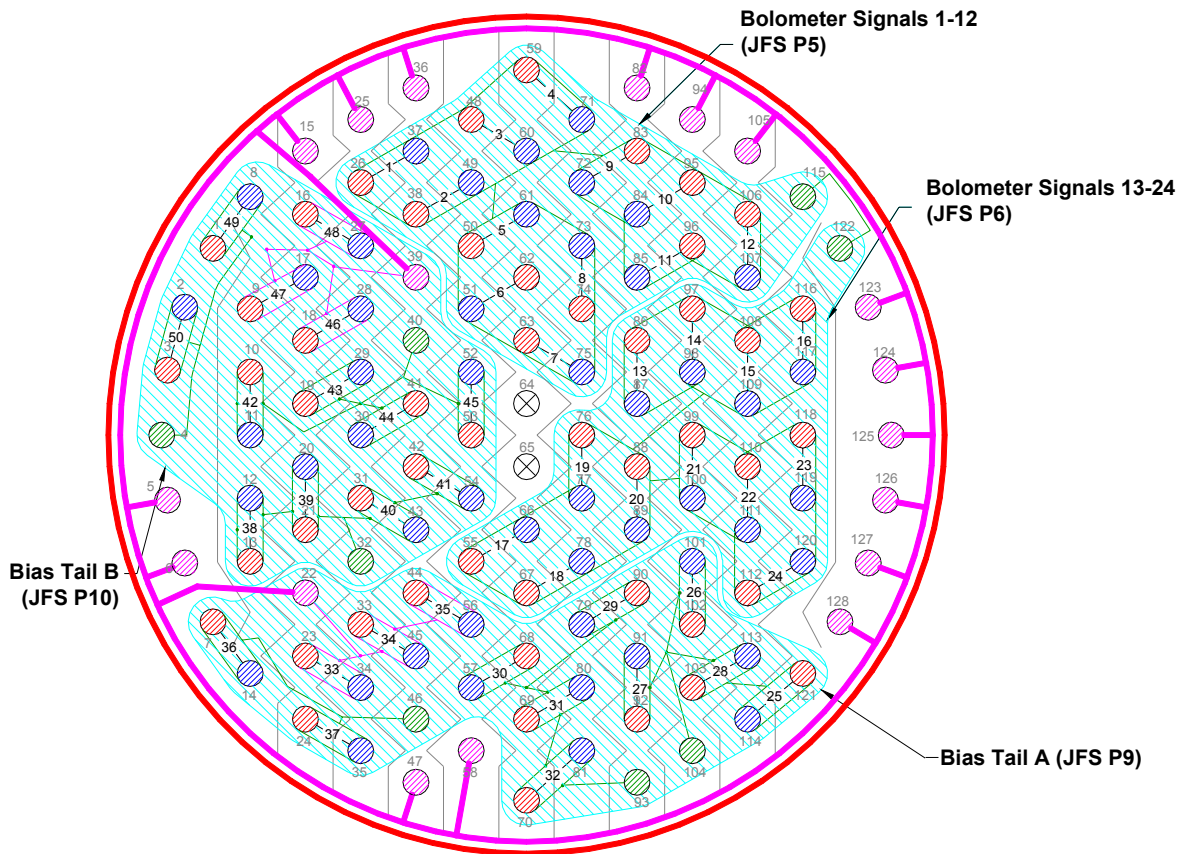

- Signal Supply Pin
- Signal Return Pin
- Signal Ground Pin
- FPU Faraday Shield Link Pin
- No Connection
- Harness Tails
- Connector Chassis (isolated from FPU Faraday Shield)
- FPU Faraday Shield (i.e. Harness overshield - isolated from S/C structure)
- Ground Plane Interconnection

Overshields of the 12-ax and STP are commoned as indicated by signal ground connections and passed through the 128-way by dedicated ground pins.

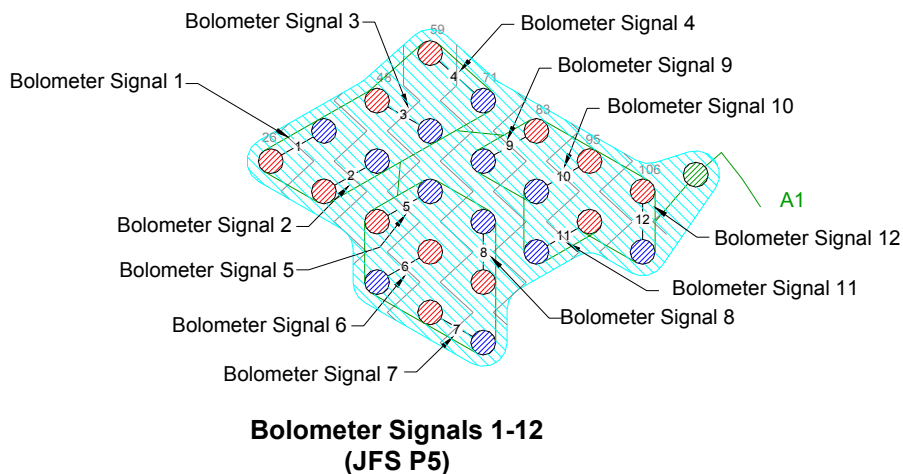



SPIRE HARNESS DEFINITION DOCUMENT

Doc: SPIRE-RAL-PRJ-000608
Issue: 1.2
Date: 17/02/05
Page 119 of 245

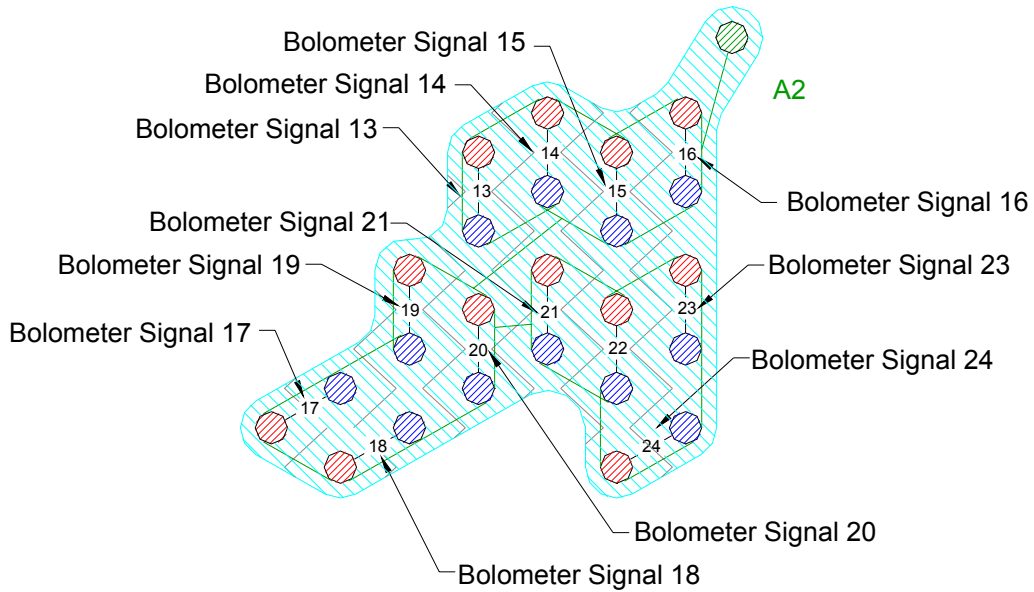

**Bolometer Signals 13-24
(JFS P6)**

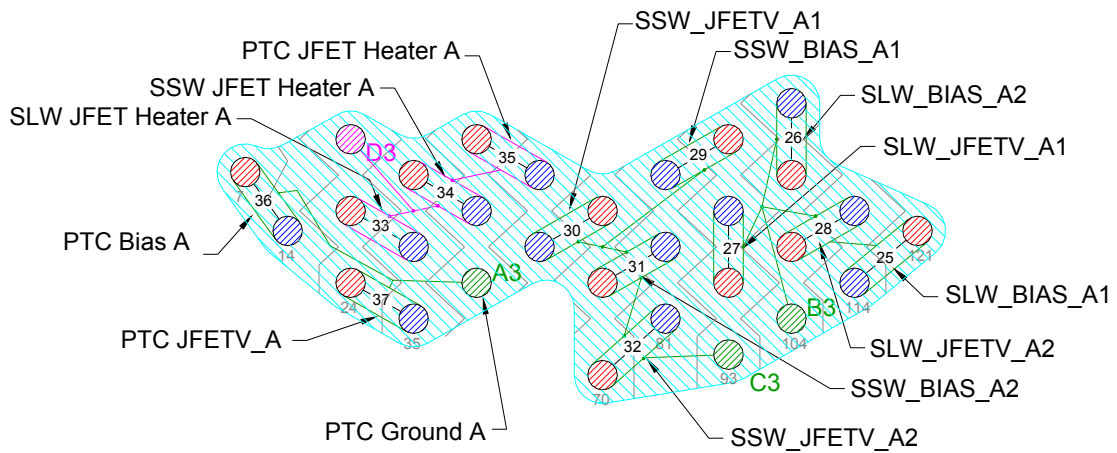

**Bias Tail A
(JFS P9)**



SPIRE HARNESS DEFINITION DOCUMENT

Doc: SPIRE-RAL-PRJ-000608

Issue: 1.2

Date: 17/02/05

Page 120 of 245

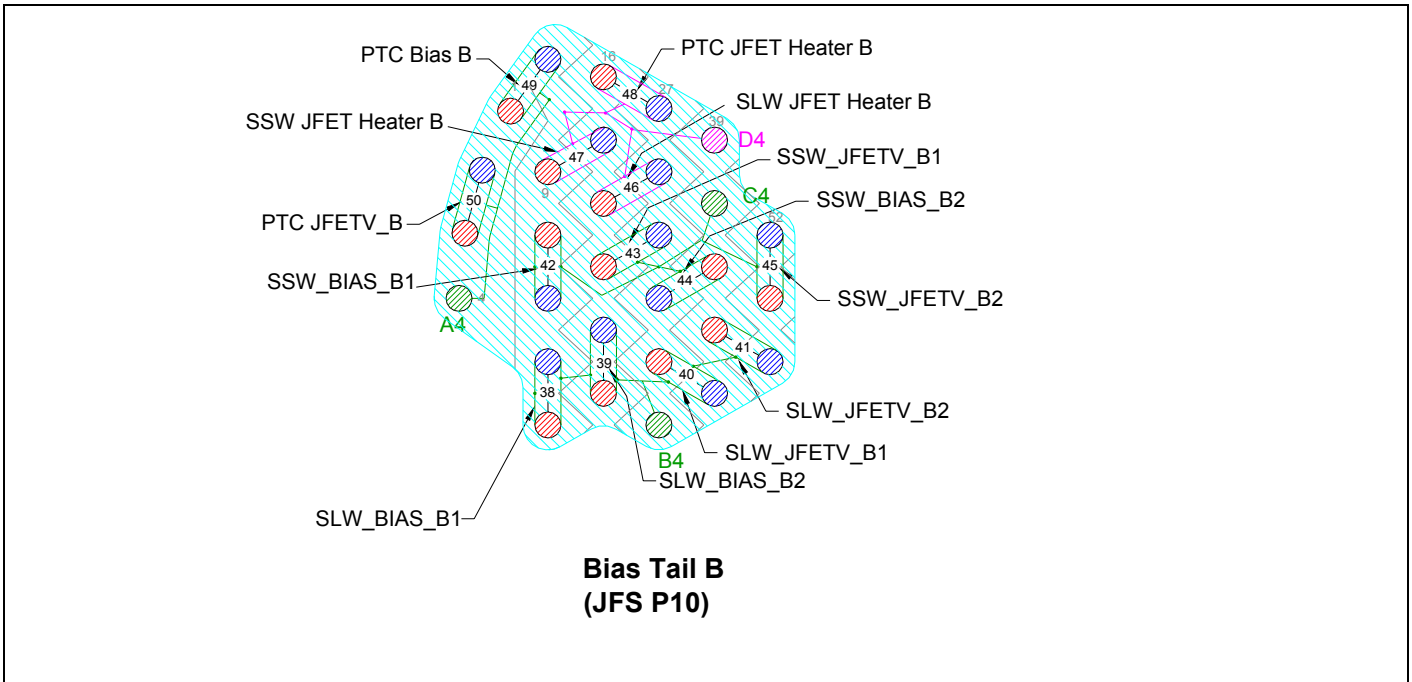

Table 4.4-1 - SIH-CS-01 Listing

	Name	Pixel	JFS P05	JFS P06	37-Way C JFS P09	37-Way D JFS P10	CVV 128-Way #1
C1-12ax-A	Channel 1 +	SLW-R1	1				26
	Channel 1 -		14				37
	Channel 1gnd shld		13 (A)				115 (A1)
	Channel 2 +	SLW-T1	2				38
	Channel 2 -		15				49
	Channel 2gnd shld		13 (A)				115 (A1)
	Channel 3 +	SLW-C1	3				48
	Channel 3 -		16				60
	Channel 3gnd shld		13 (A)				115 (A1)
	Channel 4 +	SLW-DK1	4				59
Channel 4 -	17					71	
Channel 4gnd shld	13 (A)					115 (A1)	
C1-12ax-B	Channel 5 +	SLW-B1	5				50
	Channel 5 -		18				61
	Channel 5gnd shld		13 (A)				115 (A1)
	Channel 6 +	SLW-D1	6				62
	Channel 6 -		19				51
	Channel 6gnd shld		13 (A)				115 (A1)
	Channel 7 +	SLW-E1	20				63
	Channel 7 -		7				75
	Channel 7gnd shld		13 (A)				115 (A1)
	Channel 8 +	SLW-A1	21				74
Channel 8 -	8					73	
Channel 8gnd shld	13 (A)					115 (A1)	
C1-12ax-C	Channel 9 +	SLW-C2	22				83
	Channel 9 -		9				72
	Channel 9gnd shld		13 (A)				115 (A1)
	Channel 10 +	SLW-D2	23				95
	Channel 10 -		10				84
	Channel 10gnd shld		13 (A)				115 (A1)
	Channel 11 +	SLW-B2	24				96
	Channel 11 -		11				85
	Channel 11gnd shld		13 (A)				115 (A1)
	Channel 12 +	SLW-E2	25				106
Channel 12 -	12					107	
Channel 12gnd shld	13 (A)					115 (A1)	
C1-12ax-D	Channel 13 +	SLW-A2		1			86
	Channel 13 -			14			87
	Channel 1gnd shld			13 (A)			122 (A2)
	Channel 14 +	SLW-C3		2			97



SPIRE HARNESS DEFINITION DOCUMENT

Doc: SPIRE-RAL-PRJ-000608
Issue: 1.2
Date: 17/02/05
Page 121 of 245

	Name	Pixel	JFS P05	JFS P06	37-Way C JFS P09	37-Way D JFS P10	CVV 128-Way #1	
	Channel 14 -	SLW-D3		15			98	
	Channel 14gnd shld			13 (A)			122 (A2)	
	Channel 15 +			3			108	
	Channel 15 -			16			109	
	Channel 15gnd shld			13 (A)			122 (A2)	
	Channel 16 +		SLW-B3		4			116
	Channel 16 -				17			117
Channel 16gnd shld		13 (A)				122 (A2)		
C1-12ax-E	Channel 17 +	SLW-E3		5			55	
	Channel 17 -			18			66	
	Channel 17gnd shld			13 (A)			122 (A2)	
	Channel 18 +	SLW-C4		6			67	
	Channel 18 -			19			78	
	Channel 18gnd shld			13 (A)			122 (A2)	
	Channel 19 +	SLW-DK2		20			76	
	Channel 19 -			7			77	
	Channel 19 gnd shld			13 (A)			122 (A2)	
	Channel 20 +	SLW-D4		21			88	
	Channel 20 -			8			89	
	Channel 20 gnd shld			13 (A)			122 (A2)	
C1-12ax-F	Channel 21 +	SLW-C5		22			99	
	Channel 21 -			9			100	
	Channel 21gnd shld			13 (A)			122 (A2)	
	Channel 22 +	SLW-B4		23			110	
	Channel 22 -			10			111	
	Channel 22gnd shld			13 (A)			122 (A2)	
	Channel 23 +	SLW-A3		24			118	
	Channel 23 -			11			119	
	Channel 23gnd shld			13 (A)			122 (A2)	
	Channel 24 +	SLW-T2		25			112	
	Channel 24 -			12			120	
	Channel 24gnd shld			13 (A)			122 (A2)	
STP	PTC Bias A +ve				1		7	
	PTC Bias A -ve				20		14	
	PTC Bias A Shield				2 (A3)		46 (A3)	
S	PTC Ground A				2 (A3)		46 (A3)	
STP	PTC JFETV Bias A +ve				21		24	
	PTC JFETV Bias A -ve				3		35	
	PTC JFETV Bias A Shield				2 (A3)		46 (A3)	
STP	SLW BIAS A1+ve				22		121	
	SLW BIAS A1-ve				4		114	
	SLW BIAS A1 shld				6(B3)		104(B3)	
STP	SLW BIAS A2 +ve				5		102	
	SLW BIAS A2 -ve				24		101	
	SLW BIAS A2 shld				23(B3)		104(B3)	
STP	SLW JFETV A1 +ve				25		92	
	SLW JFETV A1 -ve				7		91	
	SLW JFETV A1 shld				6(B3)		104(B3)	
STP	SLW JFETV A2 +ve				8		103	
	SLW JFETV A2 -ve				27		113	
	SLW JFETV A2 shld				26(B3)		104(B3)	
S	SLW GND WIRE A				6(B3)		104(B3)	
STP	SSW BIAS1 A +ve				28		90	
	SSW BIAS1 A -ve				10		79	
	SSW BIAS1 A shld				9(C3)		93(C3)	
STP	SSW JFETV1 A +ve				11		68	
	SSW JFETV1 A -ve				30		57	
	SSW JFETV1 A shld				29(C3)		93(C3)	
S	SSW GND WIRE A				12(C3)		93(C3)	
STP	SSW BIAS2 A +ve				13		69	
	SSW BIAS2 A -ve				32		80	
	SSW BIAS2 A shld				31(C3)		93(C3)	
STP	SSW JFETV2 A +ve				33		70	
	SSW JFETV2 A -ve				15		81	
	SSW JFETV2 A shld				14(C3)		93(C3)	
S	S HEATER GROUND A				NC		22(D3)	
STP	SLW JFET HEATER A +ve				17		23	
	SLW JFET HEATER A -ve				36		34	
	SLW JFET HEATER A shld				18(D3)		22(D3)	
S	SLW JFET HEATER A +ve				37		33	



SPIRE HARNESS DEFINITION DOCUMENT

Doc: SPIRE-RAL-PRJ-000608
Issue: 1.2
Date: 17/02/05
Page 122 of 245

	Name	Pixel	JFS P05	JFS P06	37-Way C JFS P09	37-Way D JFS P10	CVV 128-Way #1
	SSW_JFET_HEATER_A_-ve				19		45
	SSW_JFET_HEATER_A_shld				18(D3)		22(D3)
STP	PTC_JFET_HEATER_A_+ve				16		44
	PTC_JFET_HEATER_A_-ve				35		56
	PTC_JFET_HEATER_A_shld				NC		22(D3)
STP	PTC_Bias_B_+ve					1	1
	PTC_Bias_B_-ve					20	8
	PTC_Bias_B_Shield					2(A4)	4(A4)
S	PTC_Ground_B					2(A4)	4(A4)
STP	PTC_JFETV_Bias_B_+ve					21	3
	PTC_JFETV_Bias_B_-ve					3	2
	PTC_JFETV_Bias_B_Shield					2(A4)	4(A4)
STP	SLW_BIAS_B1+ve					22	13
	SLW_BIAS_B1-ve					4	12
	SLW_BIAS_B1_shld					6(B4)	32(B4)
STP	SLW_BIAS_B2+ve					5	21
	SLW_BIAS_B2_-ve					24	20
	SLW_BIAS_B2_shld					23(B4)	32(B4)
STP	SLW_JFETV_B1_+ve					25	31
	SLW_JFETV_B1_-ve					7	43
	SLW_JFETV_B1_shld					6(B4)	32(B4)
STP	SLW_JFETV_B2_+ve					8	42
	SLW_JFETV_B2_-ve					27	54
	SLW_JFETV_B2_shld					26(B4)	32(B4)
S	SLW_GND_WIRE_B					6(B4)	32(B4)
S	SSW_GND_WIRE_B					12(C4)	40(C4)
STP	SSW_BIAS1_B_+ve					28	10
	SSW_BIAS1_B_-ve					10	11
	SSW_BIAS1_B_shld					9(C4)	40(C4)
STP	SSW_JFETV1_B_+ve					11	19
	SSW_JFETV1_B_-ve					30	29
	SSW_JFETV1_B_shld					29(C4)	40(C4)
STP	SSW_BIAS2_B_+ve					13	41
	SSW_BIAS2_B_-ve					32	30
	SSW_BIAS2_B_shld					31(C4)	40(C4)
STP	SSW_JFETV2_B_+ve					33	53
	SSW_JFETV2_B_-ve					15	52
	SSW_JFETV2_B_shld					14(C4)	40(C4)
S	S_HEATER_GROUND_B					NC	39(D4)
STP	SLW_HEATER_B_+ve					17	18
	SLW_HEATER_B_-ve					36	28
	SLW_HEATER_B_shld					18(D4)	39(D4)
STP	SSW_HEATER_B_+ve					37	9
	SSW_HEATER_B_-ve					19	17
	SSW_HEATER_B_shld					18(D4)	39(D4)
STP	PTC_JFET_HEATER_A_+ve					16	16
	PTC_JFET_HEATER_A_-ve					35	27
	PTC_JFET_HEATER_A_shld					NC	39(D4)
	Harness Overshield		EMC Backshell	EMC Backshell	EMC Backshell	EMC Backshell	

FPU Faraday Shield Link Pins S1/I1/C1								
5	6	15	22	25	36	39	47	58
82	94	105	123	124	125	126	127	128



SPIRE HARNESS DEFINITION DOCUMENT

Doc: SPIRE-RAL-PRJ-000608

Issue: 1.2

Date: 17/02/05

Page 123 of 245

4.4.2 C2 CVV2 to HSJFS Type4

Overall Mechanical Drawing

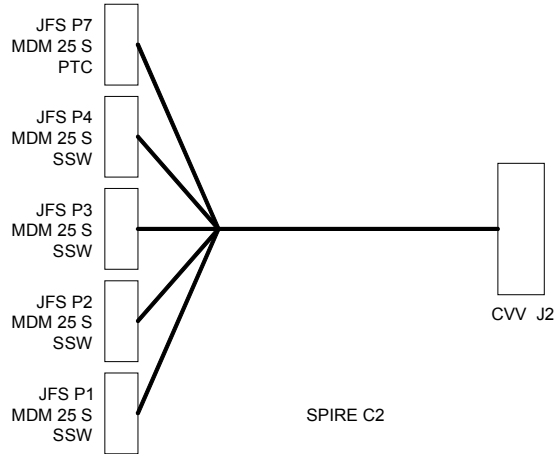

Connector/Backshell Details

MDM 25 S	+	Glenair	507	-	T	-	196	-	M- 25	to	JFSJ1	SSW JFET
MDM 25 S	+	Glenair	507	-	T	-	196	-	M- 25	to	JFSJ2	SSW JFET
MDM 25 S	+	Glenair	507	-	T	-	196	-	M- 25	to	JFSJ3	SSW JFET
MDM 25 S	+	Glenair	507	-	T	-	196	-	M- 25	to	JFSJ4	SSW JFET
MDM 25 S	+	Glenair	507	-	T	-	196	-	M- 25	to	JFSJ7	PTC

Harness Layup

Tails P1, P2 and P4 similar to tails in C4

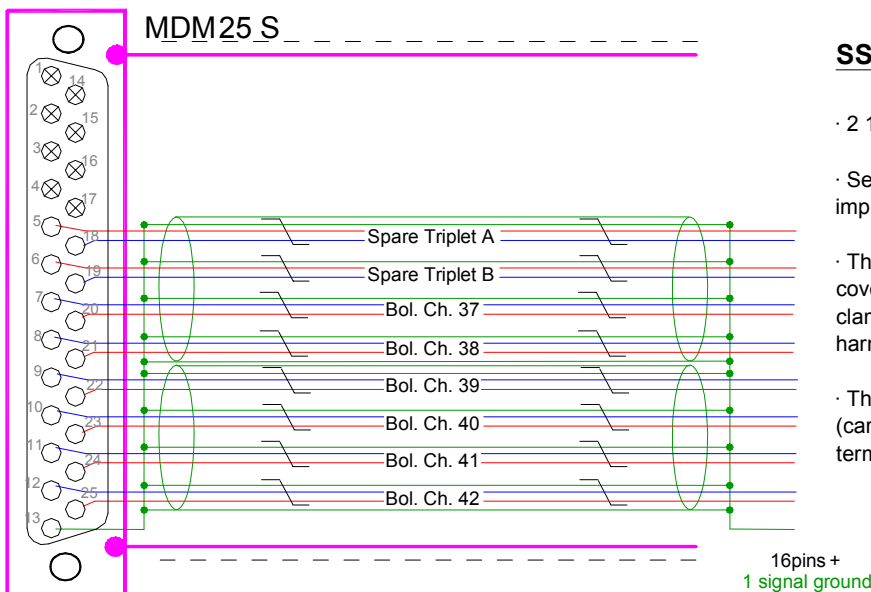

SSW JFET Tail (JFS P3)

- 2 12-ax
- See Section 4.4 for details regarding the implementation of the shields.
- The dotted lines indicate insulation jacket covering the overshield. Only required at clamp points but could cover entire length of harness.
- The signals from the two Spare Triplets (carried on pins 5, 18, 6 and 19 on JFS P1) terminate on open pins on the 128-Way #2.



SPIRE HARNESS DEFINITION DOCUMENT

Doc: SPIRE-RAL-PRJ-000608

Issue: 1.2

Date: 17/02/05

Page 124 of 245

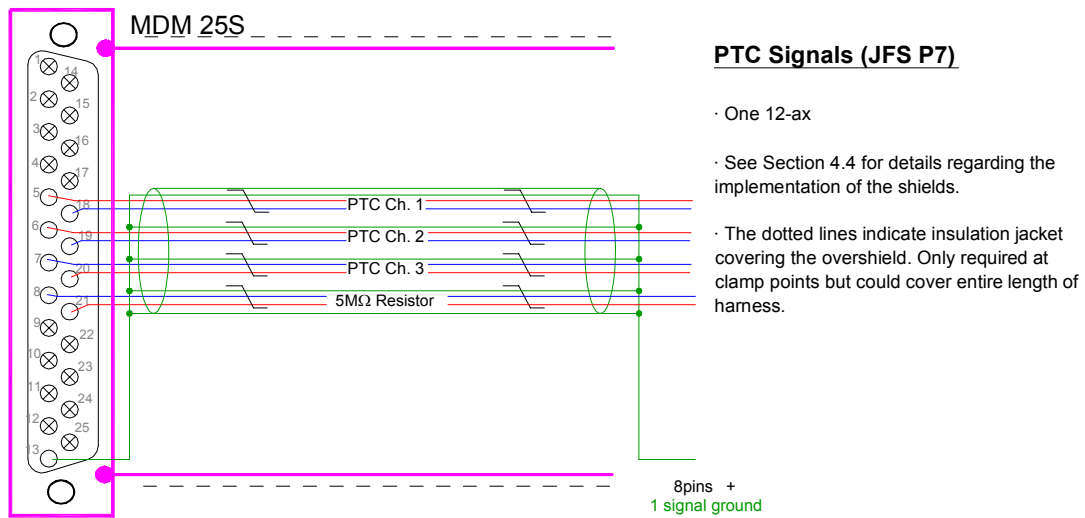

Note: The 5MΩ Resistor is wired to the CVV wall and shorted in the “I-Harness” CVV Connector

CVV C2 128-Way Pin Allocations (View of wiring side of connector)

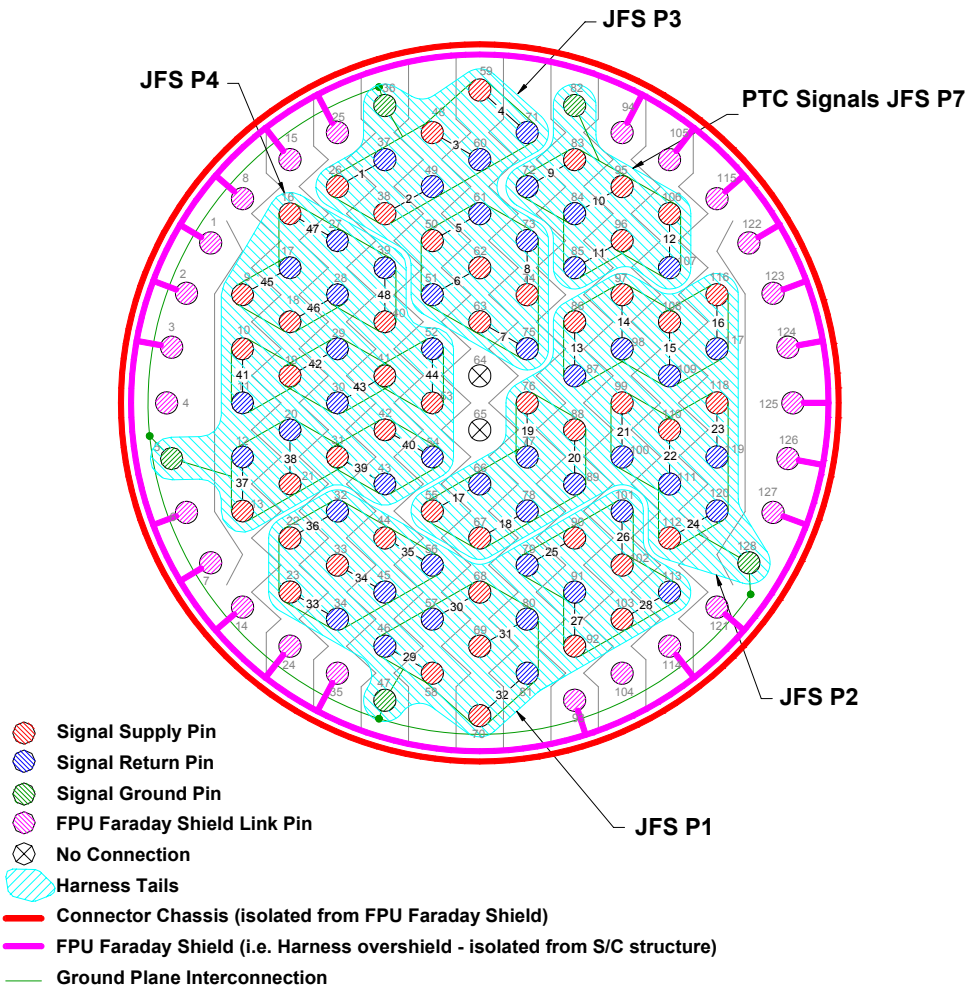

Overshields of the 12-ax and STP are commoned as indicated by signal ground connections and passed through the 128-way by dedicated ground pins.



SPIRE HARNESS DEFINITION DOCUMENT

Doc: SPIRE-RAL-PRJ-000608

Issue: 1.2

Date: 17/02/05

Page 125 of 245

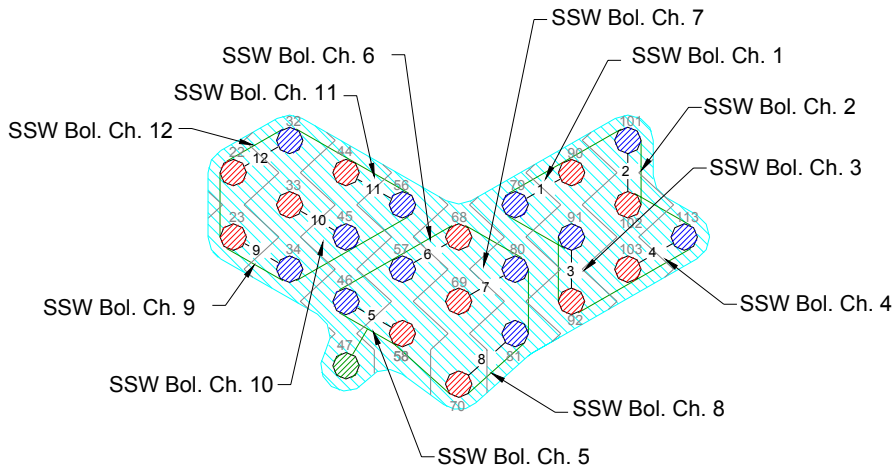

JFS P01

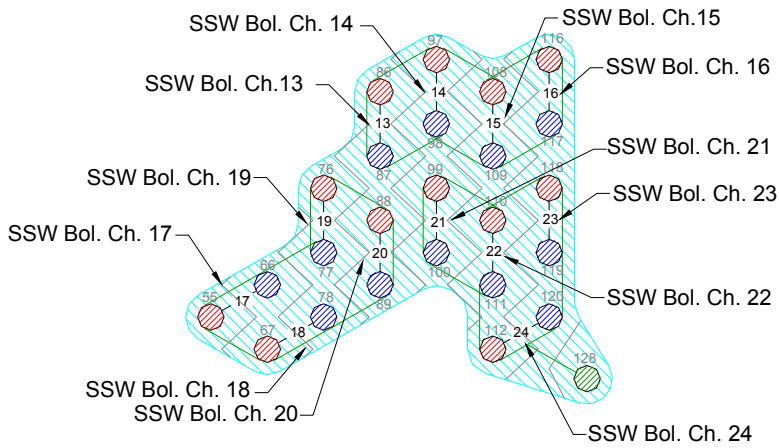

JFS P02



SPIRE HARNESS DEFINITION DOCUMENT

Doc: SPIRE-RAL-PRJ-000608

Issue: 1.2

Date: 17/02/05

Page 126 of 245

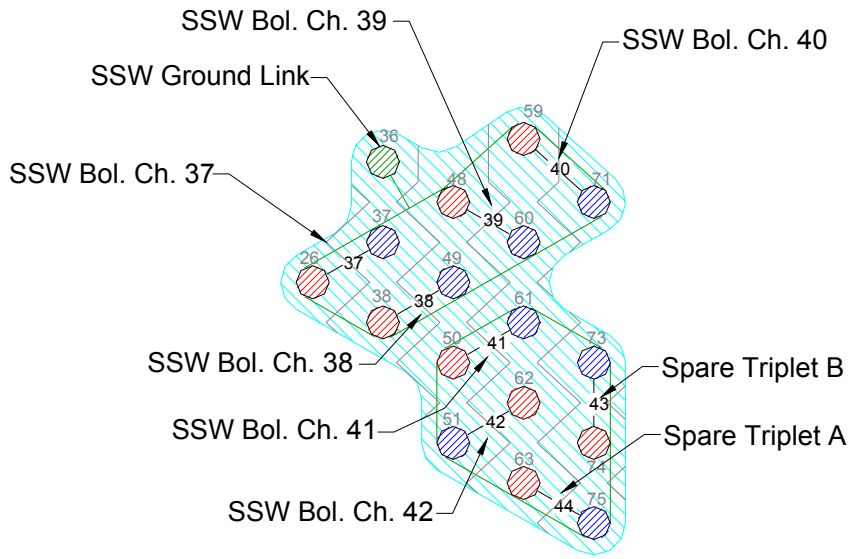

JFS P03

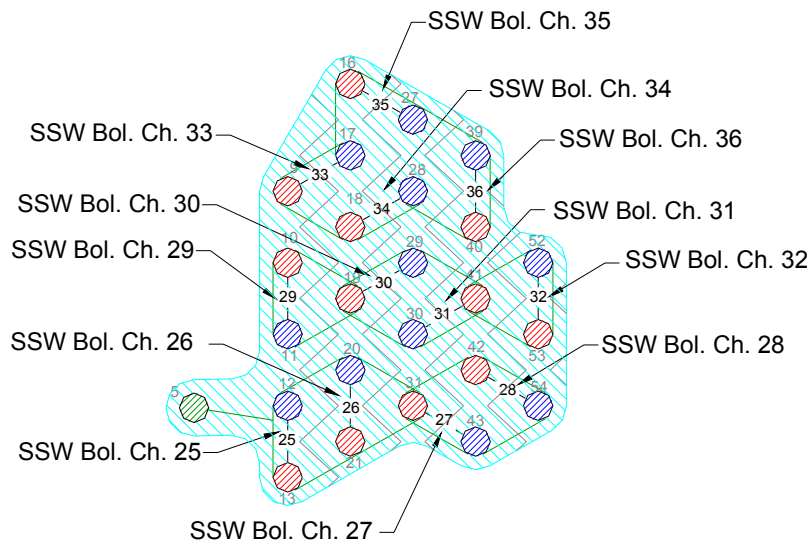

JFS P04



SPIRE HARNESS DEFINITION DOCUMENT

Doc: SPIRE-RAL-PRJ-000608
Issue: 1.2
Date: 17/02/05
Page 127 of 245

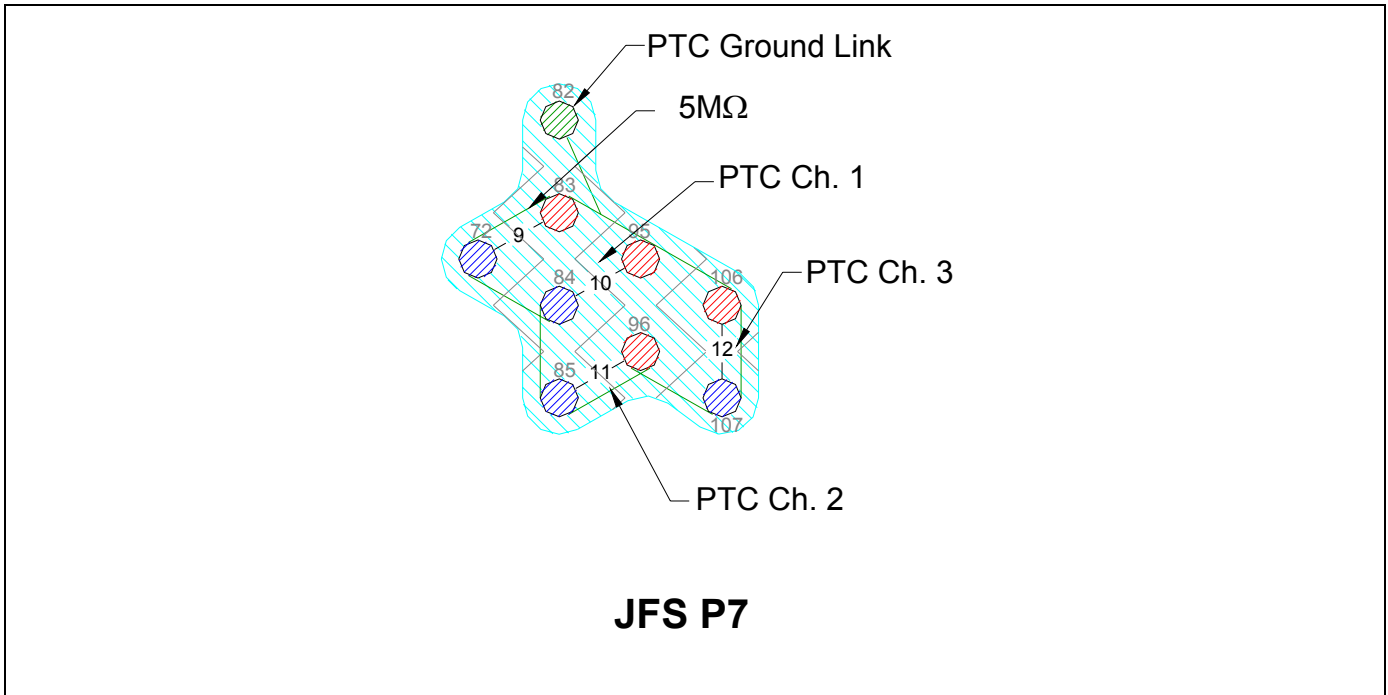

Note:

- Pin numbers suffixed by a letter in parentheses indicated the commoning of pins within the 128-way connector. Note the separation of the SSW Ground reference and the PTC Ground Reference.
- The two spare triplets terminate on open pins on the 128-Way.

Table 4.4-2 - SIH-CS-02 Listing

Type	Name	Pixel	JFS P01	JFS P02	JFS P03	JFS P04	JFS P07	128Way #2
C2-12ax-G	Bol. Channel 1 +	SSW-R1	1					90
	Bol. Channel 1 -		14					79
	Bol. Channel 1gnd		13 (A)					47(A)
	Bol. Channel 2 +	SSW-A4	2					102
	Bol. Channel 2 -		15					101
	Bol. Channel 2gnd		13 (A)					47(A)
	Bol. Channel 3 +	SSW-A3	3					92
	Bol. Channel 3 -		16					91
	Bol. Channel 3gnd		13 (A)					47(A)
	Bol. Channel 4 +	SSW-A2	4					103
Bol. Channel 4 -	17						113	
Bol. Channel 4gnd	13 (A)						47(A)	
C2-12ax-H	Bol. Channel 5 +	SSW-A1	5					58
	Bol. Channel 5 -		18					46
	Bol. Channel 5gnd		13 (A)					47(A)
	Bol. Channel 6 +	SSW-DK1	6					68
	Bol. Channel 6 -		19					57
	Bol. Channel 6gnd		13 (A)					47(A)
	Bol. Channel 7 +	SSW-B3	20					69
	Bol. Channel 7 -		7					80
	Bol. Channel 7gnd		13 (A)					47(A)
	Bol. Channel 8 +	SSW-B2	21					70
Bol. Channel 8 -	8						81	
Bol. Channel 8gnd	13 (A)						47(A)	
C2-12ax-I	Bol. Channel 9 +	SSW-B1	22					23
	Bol. Channel 9 -		9					34
	Bol. Channel 9gnd		13 (A)					47(A)
	Bol. Channel 10 +	SSW-C3	23					33
	Bol. Channel 10 -		10					45
	Bol. Channel 10gnd		13 (A)					47(A)
Bol. Channel 11 +	SSW-C2	24					44	



SPIRE HARNESS DEFINITION DOCUMENT

Doc: SPIRE-RAL-PRJ-000608
Issue: 1.2
Date: 17/02/05
Page 128 of 245

Type	Name	Pixel	JFS P01	JFS P02	JFS P03	JFS P04	JFS P07	128Way #2
	Bol. Channel 11 -	SSW-C1	11					56
	Bol. Channel 11gnd		13 (A)					47(A)
	Bol. Channel 12 +		25					22
	Bol. Channel 12 -		12					32
	Bol. Channel 12gnd		13 (A)					47(A)
C2-12ax-J	Bol. Channel 13 +	SSW-D3		1				86
	Bol. Channel 13 -			14				87
	Bol. Channel 13gnd			13 (A)				128(A)
	Bol. Channel 14 +	SSW-D2		2				97
	Bol. Channel 14 -			15				98
	Bol. Channel 14 gnd			13 (A)				128 (A)
	Bol. Channel 15 +	SSW-D1		3				108
	Bol. Channel 15 -			16				109
	Bol. Channel 15gnd			13 (A)				128 (A)
	Bol. Channel 16 +	SSW-E3		4				116
	Bol. Channel 16 -			17				117
	Bol. Channel 16gnd			13 (A)				128 (A)
C2-12ax-K	Bol. Channel 17 +	SSW-E2		5				55
	Bol. Channel 17 -			18				66
	Bol. Channel 17gnd			13 (A)				128(A)
	Bol. Channel 18 +	SSW-E1		6				67
	Bol. Channel 18 -			19				78
	Bol. Channel 18gnd			13 (A)				128(A)
	Bol. Channel 19 +	SSW-F3		20				76
	Bol. Channel 19 -			7				77
	Bol. Channel 19gnd			13 (A)				128(A)
	Bol. Channel 20 +	SSW-F2		21				88
	Bol. Channel 20 -			8				89
	Bol. Channel 20gnd			13 (A)				128(A)
C2-12ax-L	Bol. Channel 21 +	SSW-F1		22				99
	Bol. Channel 21 -			9				100
	Bol. Channel 21gnd			13 (A)				128(A)
	Bol. Channel 22 +	SSW-G1		23				110
	Bol. Channel 22 -			10				111
	Bol. Channel 22gnd			13 (A)				128(A)
	Bol. Channel 23 +	SSW-T1		24				118
	Bol. Channel 23 -			11				119
	Bol. Channel 23gnd			13 (A)				128(A)
	Bol. Channel 24 +	SSW-G2		25				112
	Bol. Channel 24 -			12				120
	Bol. Channel 24gnd			13 (A)				128(A)
C2-12ax-D	Bol. Channel 25 +	SSW-E5				1		13
	Bol. Channel 25 -					14		12
	Bol. Channel 25gnd					13 (A)		5(A)
	Bol. Channel 26 +	SSW-E4				2		21
	Bol. Channel 26 -					15		20
	Bol. Channel 26gnd					13 (A)		5(A)
	Bol. Channel 27 +	SSW-D7				3		31
	Bol. Channel 27 -					16		43
	Bol. Channel 27gnd					13 (A)		5(A)
	Bol. Channel 28 +	SSW-D6				4		42
	Bol. Channel 28 -					17		54
	Bol. Channel 28gnd					13 (A)		5(A)
C2-12ax-E	Bol. Channel 29 +	SSW-D5				5		10
	Bol. Channel 29 -					18		11
	Bol. Channel 29gnd					13 (A)		5(A)
	Bol. Channel 30 +	SSW-D4				6		19
	Bol. Channel 30 -					19		29
	Bol. Channel 30gnd					13 (A)		5(A)
	Bol. Channel 31 +	SSW-C6				20		41
	Bol. Channel 31 -					7		30
	Bol. Channel 31gnd					13 (A)		5(A)
	Bol. Channel 32 +	SSW-C5				21		53
	Bol. Channel 32 -					8		52
	Bol. Channel 32gnd					13 (A)		5(A)
C2-12ax-F	Bol. Channel 33 +	SSW-C4				22		9
	Bol. Channel 33 -					9		17
	Bol. Channel 33gnd					13 (A)		5(A)
	Bol. Channel 34 +	SSW-B5				23		18
	Bol. Channel 34 -					10		28



SPIRE HARNESS DEFINITION DOCUMENT

Doc: SPIRE-RAL-PRJ-000608
Issue: 1.2
Date: 17/02/05
Page 129 of 245

Type	Name	Pixel	JFS P01	JFS P02	JFS P03	JFS P04	JFS P07	128Way #2	
	Bol. Channel 34gnd	SSW-B4				13 (A)		5(A)	
	Bol. Channel 35 +					24		16	
	Bol. Channel 35 -					11		27	
	Bol. Channel 35gnd	SSW-T2				13 (A)		5(A)	
	Bol. Channel 36 +					25		40	
	Bol. Channel 36 -					12		39	
	Bol. Channel 36gnd					13 (A)		5(A)	
C2-12ax-B	SPARE 1+	SPARE - 1			5			63	
	SPARE 1-				18			75	
	SPARE 1 GND				13 (A)			36(A)	
	SPARE 2 +	SPARE - 2			6			74	
	SPARE 2 -				19			73	
	SPARE 2 GND				13 (A)			36(A)	
		Bol. Channel 37 +	SSW-G3			20			26
		Bol. Channel 37 -				7			37
		Bol. Channel 37gnd				13 (A)			36(A)
		Bol. Channel 38 +	SSW-G4			21			38
	Bol. Channel 38 -				8			49	
	Bol. Channel 38gnd				13 (A)			36(A)	
C2-12ax-C	Bol. Channel 39 +	SSW-DK2			22			48	
	Bol. Channel 39 -				9		60		
	Bol. Channel 39gnd				13 (A)			36(A)	
	Bol. Channel 40 +	SSW-F5			23			59	
	Bol. Channel 40 -				10		71		
	Bol. Channel 40gnd				13 (A)			36(A)	
	Bol. Channel 41 +	SSW-F4			24			50	
	Bol. Channel 41 -				11		61		
	Bol. Channel 41gnd				13 (A)			36(A)	
	Bol. Channel 42 +	SSW-E6			25			62	
Bol. Channel 42 -				12		51			
Bol. Channel 42gnd				13 (A)			36(A)		
C2-12ax-L	PTC Channel 1 +	PTC-1					5	95	
	PTC Channel 1 -					18	84		
	PTC Channel 1gnd					13 (A)	82(B)		
	PTC Channel 2 +	PTC-2				6	96		
	PTC Channel 2 -					19	85		
	PTC Channel 2gnd					13 (A)	82(B)		
	PTC Channel 3 +	PTC-3				20	106		
	PTC Channel 3 -					7	107		
	PTC Channel 3gnd					13 (A)	82(B)		
	PTC 5MΩ Resistor +	5MΩ-1					21	83	
PTC 5MΩ Resistor -					8	72			
PTC 5MΩ Resistor gnd					13 (A)	82(B)			
	Harness Overshield		EMC Backshell	EMC Backshell	EMC Backshell	EMC Backshell	EMC Backshell	EMC Backshell	

FPU Faraday Shield Link Pins C2/S2													
1	2	3	5	6	7	8	14	15	24	25	35	93	
94	104	105	114	115	121	122	123	124	125	126	127		

4.4.3 C3 CVV3 to HSJFP Type2

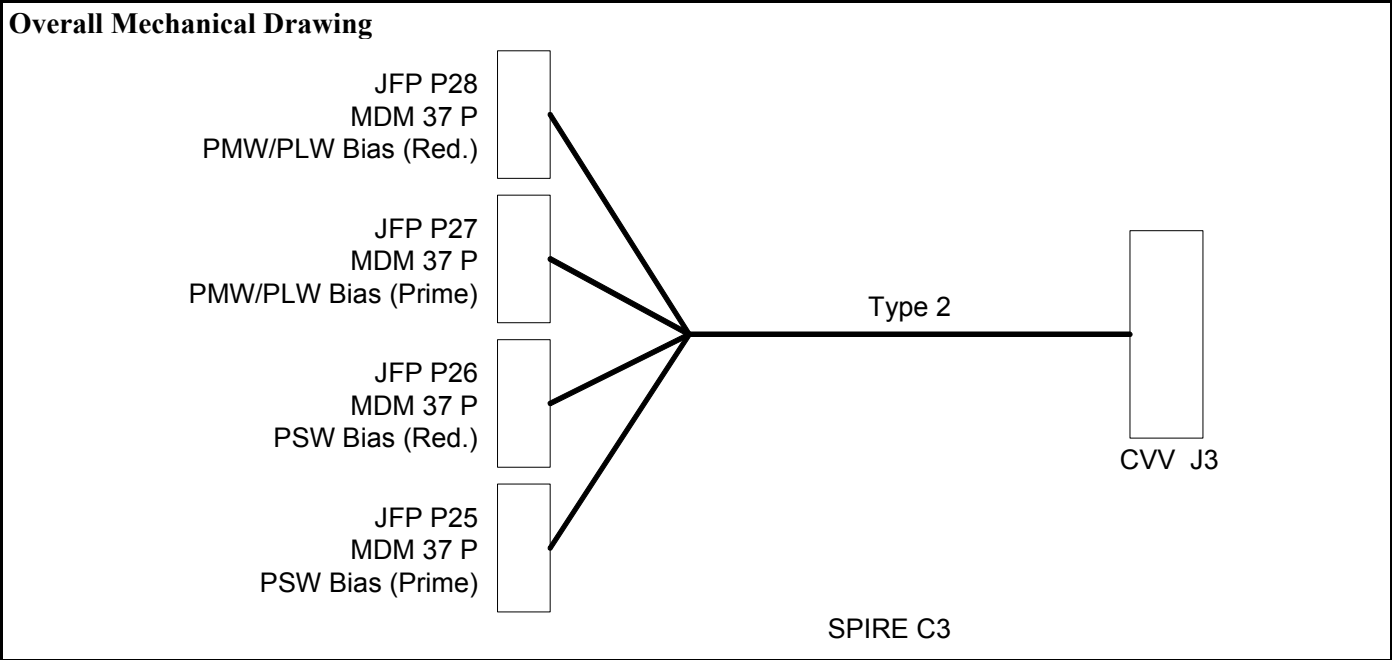

Connector/Backshell Details

MDM 37 P+Glenair 507 - T-196-M-37 to	JFPJ25 PSW Bias (P)
MDM 37 P+Glenair 507 - T-196-M-37 to	JFPJ26 PSW Bias (R)
MDM 37 P+Glenair 507 - T-196-M-37 to	JFPJ27 PMW/PLW Bias (P)
MDM 37 P+Glenair 507 - T-196-M-37 to	JFPJ28 PMW/PLW Bias (R)

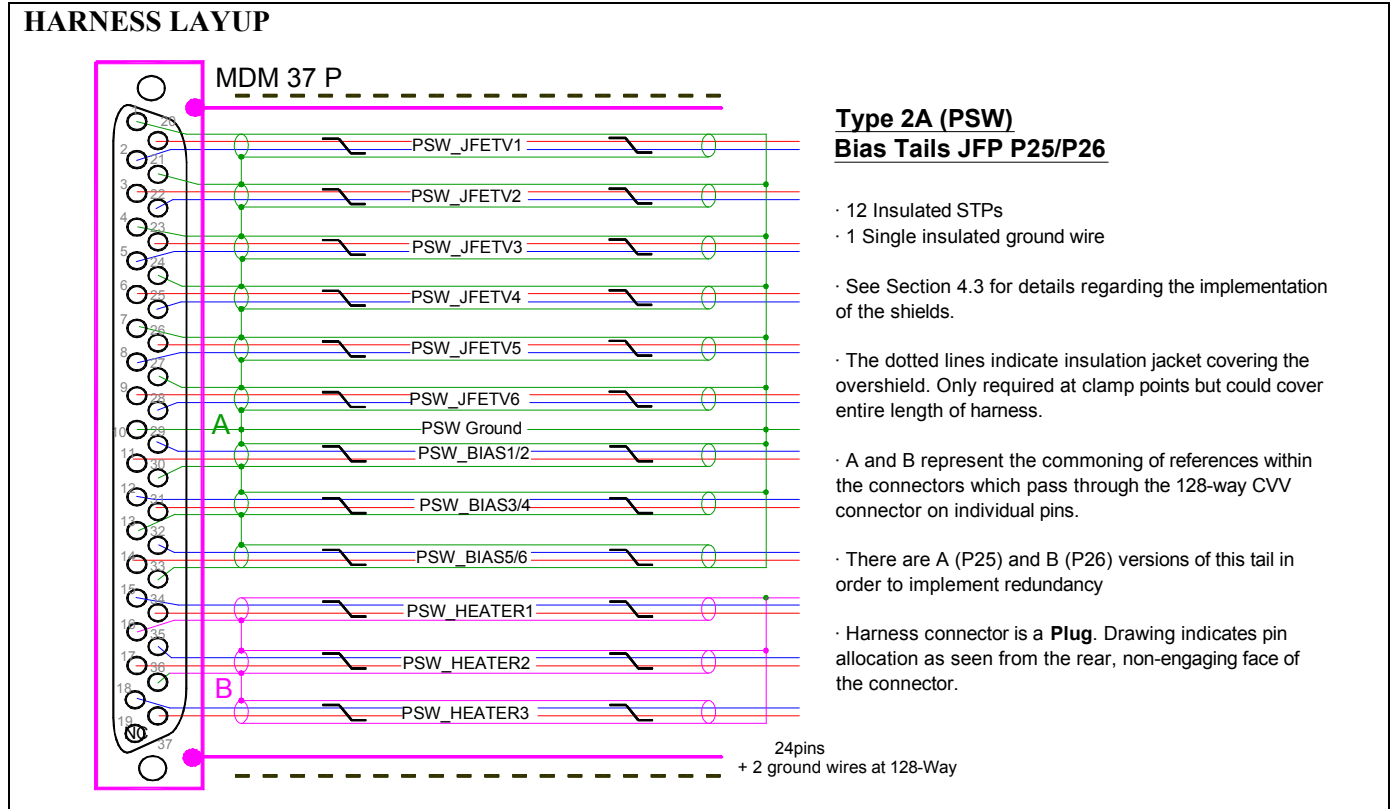



SPIRE HARNESS DEFINITION DOCUMENT

Doc: SPIRE-RAL-PRJ-000608

Issue: 1.2

Date: 17/02/05

Page 131 of 245

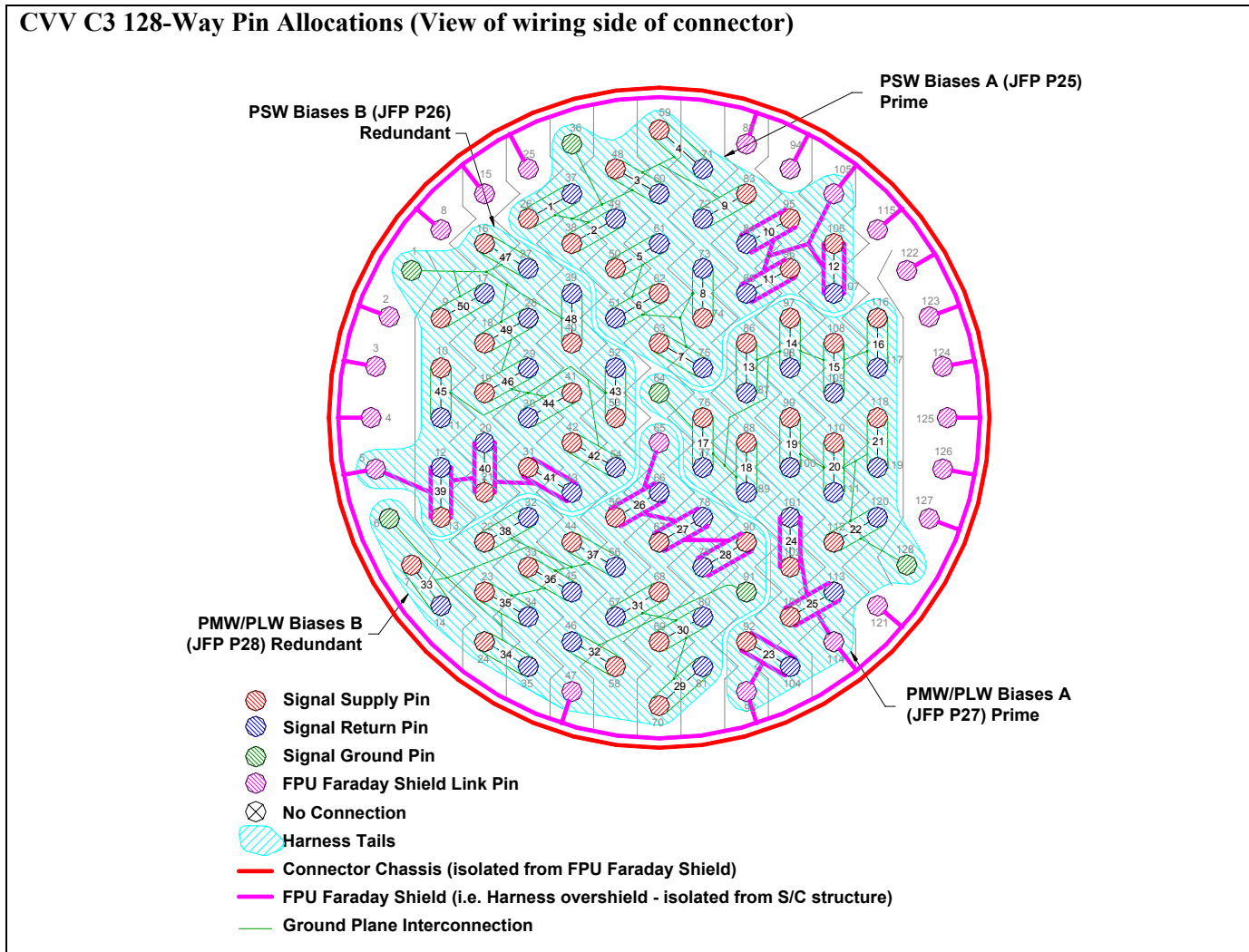
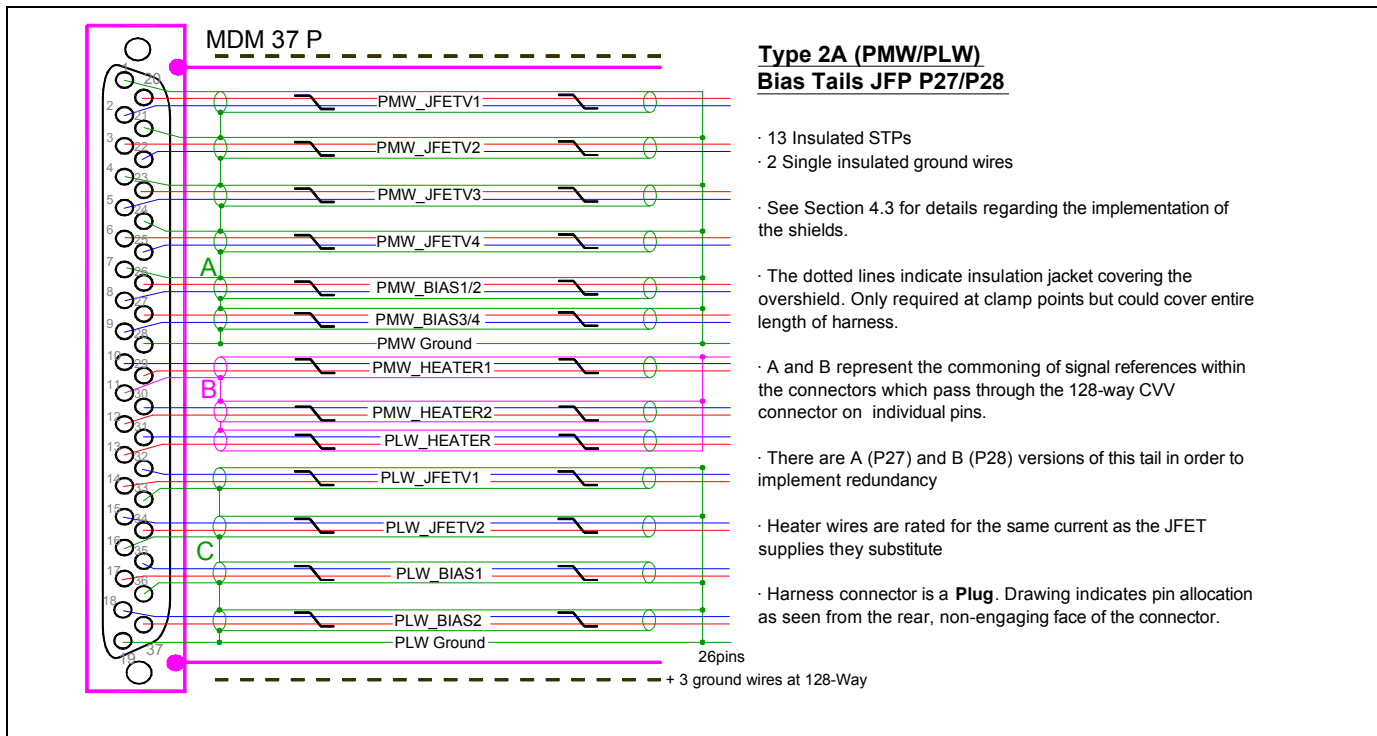



SPIRE HARNESS DEFINITION DOCUMENT

Doc: SPIRE-RAL-PRJ-000608

Issue: 1.2

Date: 17/02/05

Page 132 of 245

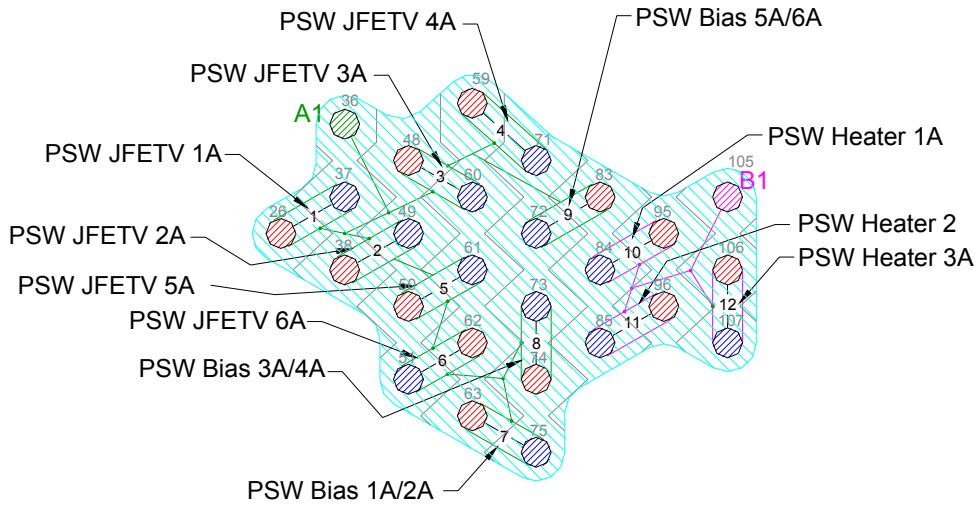

**PSW Biases A (JFP P25)
Prime**

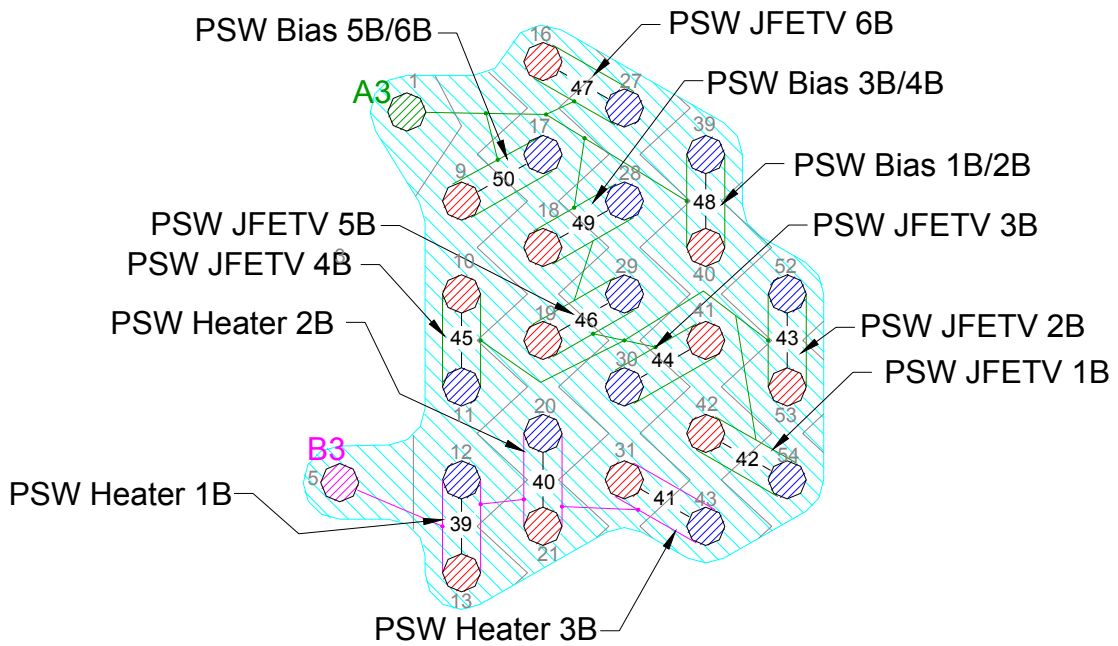

**PSW Biases B (JFP P26)
Redundant**



SPIRE HARNESS DEFINITION DOCUMENT

Doc: SPIRE-RAL-PRJ-000608

Issue: 1.2

Date: 17/02/05

Page 133 of 245

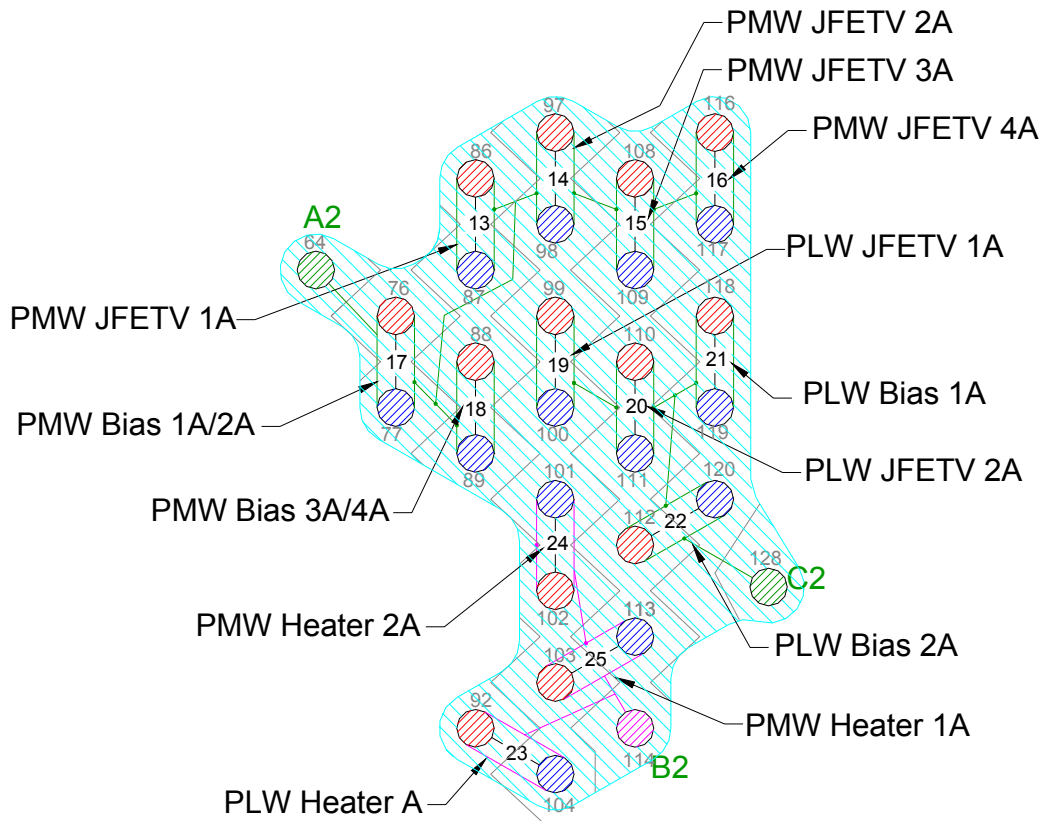

**PMW/PLW Biases A (JFP P27)
Prime**

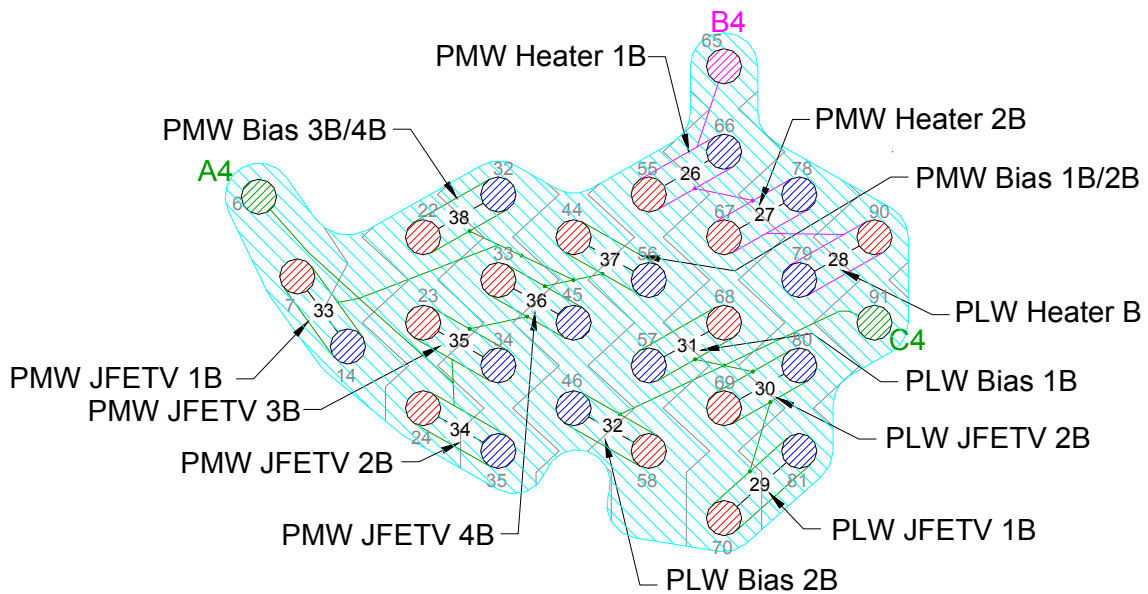

**PMW/PLW Biases B (JFP P28)
Redundant**

Contact Details

Table 4.4-3 - SIH-CS-03 Listing

Name	37-way P25 (PSW Bias A)	37-way P27 (PMW/PLW Bias A)	37-Way P26 (PSW Bias B)	37-Way P28 (PMW/PLW Bias B)	128-Way #3
PSW JFETV1 A +	20				26
PSW JFETV1 A -	2				37
PSW JFETV1 A shld	1 (A1)				36 (A1)
PSW JFETV2 A +	3				38
PSW JFETV2 A -	22				49
PSW JFETV2 A shld	21 (A1)				36 (A1)
PSW JFETV3 A +	23				48
PSW JFETV3 A -	5				60
PSW JFETV3 A shld	4 (A1)				36 (A1)
PSW JFETV4 A +	6				59
PSW JFETV4 A -	25				71
PSW JFETV4 A shld	24 (A1)				36 (A1)
PSW JFETV5 A +	26				50
PSW JFETV5 A -	8				61
PSW JFETV5 A shld	7 (A1)				36 (A1)
PSW JFETV6 A +	9				62
PSW JFETV6 A -	28				51
PSW JFETV6 A shld	27 (A1)				36 (A1)
PSW GRND A	10 (A1)				36 (A1)
PSW BIAS1/2 A +	11				63
PSW BIAS1/2 A -	29				75
PSW BIAS1/2 A shld	30 (A1)				36 (A1)
PSW BIAS3/4 A +	31				74
PSW BIAS3/4 A -	12				73
PSW BIAS3/4 A shld	13 (A1)				36 (A1)
PSW BIAS5/6 A +	14				83
PSW BIAS5/6 A -	32				72
PSW BIAS5/6 A shld	33 (A1)				36 (A1)
PSW HEATER A1 +	34				95
PSW HEATER A1 -	15				84
PSW HEATER A1 shld	16 (B1)				105 (B1)
PSW HEATER A2 +	17				96
PSW HEATER A2 -	35				85
PSW HEATER A2 shld	36 (B1)				105 (B1)
PSW HEATER A3 +	37				106
PSW HEATER A3 -	18				107
PSW HEATER A3 shld	36 (B1)				105 (B1)
PMW JFETV1 A +		20			86
PMW JFETV1 A -		2			87
PMW JFETV1 A shld		1 (A2)			64 (A2)
PMW JFETV2 A +		3			97
PMW JFETV2 A -		22			98
PMW JFETV2 A shld		21 (A2)			64 (A2)
PMW JFETV3 A +		23			108
PMW JFETV3 A -		5			109
PMW JFETV3 A shld		4 (A2)			64 (A2)
PMW JFETV4 A +		6			116
PMW JFETV4 A -		25			117
PMW JFETV4 A shld		24 (A2)			64 (A2)
PMW BIAS1/2 A +		26			76
PMW BIAS1/2 A -		8			77
PMW BIAS1/2 A shld		7 (A2)			64 (A2)
PMW BIAS3/4 A +		27			88
PMW BIAS3/4 A -		9			89
PMW BIAS3/4 A shld		28 (A2)			64 (A2)
PMW GND WIRE A		28 (A2)			64 (A2)
PMW HEATER A1 +		29			103
PMW HEATER A1 -		10			113
PMW HEATER A1 shld		11 (B2)			114 (B2)
PMW HEATER A2 +		12			102
PMW HEATER A2 -		30			101
PMW HEATER A2 shld		11 (B2)			114 (B2)



SPIRE HARNESS DEFINITION DOCUMENT

Doc: SPIRE-RAL-PRJ-000608
Issue: 1.2
Date: 17/02/05
Page 135 of 245

Name	37-way P25 (PSW Bias A)	37-way P27 (PMW/PLW Bias A)	37-Way P26 (PSW Bias B)	37-Way P28 (PMW/PLW Bias B)	128-Way #3
PLW HEATER A +		13			92
PLW HEATER A -		31			104
PLW HEATER A shld		11(B2)			93 (B2)
PLW JFETV1 A +		14			99
PLW JFETV1 A -		32			100
PLW JFETV1 A shld		33 (C2)			128 (C2)
PLW JFETV2 A +		34			110
PLW JFETV2 A -		15			111
PLW JFETV2 A shld		16 (C2)			128 (C2)
PLW BIAS1 A +		17			118
PLW BIAS1 A -		35			119
PLW BIAS1 A shld		36 (C2)			128 (C2)
PLW BIAS2 A +		37			112
PLW BIAS2 A -		18			120
PLW BIAS2 A shld		19 (C2)			128 (C2)
PLW GROUND WIRE A		19 (C2)			128 (C2)
PSW JFETV1 B +			20		42
PSW JFETV1 B -			2		54
PSW JFETV1 B shld			1 (A3)		1 (A3)
PSW JFETV2 B +			3		53
PSW JFETV2 B -			22		52
PSW JFETV2 B shld			21 (A3)		1 (A3)
PSW JFETV3 B +			23		41
PSW JFETV3 B -			5		30
PSW JFETV3 B shld			4 (A3)		1 (A3)
PSW JFETV4 B +			6		10
PSW JFETV4 B -			25		11
PSW JFETV4 B shld			24 (A3)		1 (A3)
PSW JFETV5 B +			26		19
PSW JFETV5 B -			8		29
PSW JFETV5 B shld			7 (A3)		1 (A3)
PSW JFETV6 B +			9		16
PSW JFETV6 B -			28		27
PSW JFETV6 B shld			27 (A3)		1 (A3)
PSW GRND B			10 (A3)		1 (A3)
PSW BIAS1/2 B +			11		40
PSW BIAS1/2 B -			29		39
PSW BIAS1/2 B shld			30 (A3)		1 (A3)
PSW BIAS3/4 B +			31		18
PSW BIAS3/4 B -			12		28
PSW BIAS3/4 B shld			13 (A3)		1 (A3)
PSW BIAS5/6 B +			14		9
PSW BIAS5/6 B -			32		17
PSW BIAS5/6 B shld			33 (A3)		1 (A3)
PSW HEATER B1 +			34		13
PSW HEATER B1 -			15		12
PSW HEATER B1 shld			16 (B3)		5 (B3)
PSW HEATER B2 +			17		21
PSW HEATER B2 -			35		20
PSW HEATER B2 shld			36 (B3)		5 (B3)
PSW HEATER B3 +			37		31
PSW HEATER B3 -			18		43
PSW HEATER B3 shld			36 (B3)		5 (B3)
PMW JFETV1 B +				20	7
PMW JFETV1 B -				2	14
PMW JFETV1 B shld				1 (A4)	6 (A4)
PMW JFETV2 B +				3	24
PMW JFETV2 B -				22	35
PMW JFETV2 B shld				21 (A4)	6 (A4)
PMW JFETV3 B +				23	23
PMW JFETV3 B -				5	34
PMW JFETV3 B shld				4 (A4)	6 (A4)
PMW JFETV4 B +				6	33
PMW JFETV4 B -				25	45
PMW JFETV4 B shld				24 (A4)	6 (A4)
PMW BIAS1/2 B +				26	44
PMW BIAS1/2 B -				8	56
PMW BIAS1/2 B shld				7 (A4)	6 (A4)
PMW BIAS3/4 B +				27	22
PMW BIAS3/4 B -				9	32



SPIRE HARNESS DEFINITION DOCUMENT

Doc: SPIRE-RAL-PRJ-000608
Issue: 1.2
Date: 17/02/05
Page 136 of 245

Name	37-way P25 (PSW Bias A)	37-way P27 (PMW/PLW Bias A)	37-Way P26 (PSW Bias B)	37-Way P28 (PMW/PLW Bias B)	128-Way #3
PMW_BIAS3/4_B_shld				28 (A4)	6 (A4)
PMW_GND_WIRE_B				28 (A4)	6 (A4)
PMW_HEATER_B1_+				29	55
PMW_HEATER_B1_-				10	66
PMW_HEATER_B1_shld				11 (B4)	65 (B4)
PMW_HEATER_B2_+				12	67
PMW_HEATER_B2_-				30	78
PMW_HEATER_B2_shld				11 (B4)	65 (B4)
PLW_HEATER_B_+				13	90
PLW_HEATER_B_-				31	79
PLW_HEATER_B_shld				11 (B4)	65 (B4)
PLW_JFETV1_B_+				14	70
PLW_JFETV1_B_-				32	81
PLW_JFETV1_B_shld				33 (C4)	91 (C4)
PLW_JFETV2_B_+				34	69
PLW_JFETV2_B_-				15	80
PLW_JFETV2_B_shld				16 (C4)	91 (C4)
PLW_BIAS1_B_+				17	68
PLW_BIAS1_B_-				35	57
PLW_BIAS1_B_shld				36 (C4)	91 (C4)
PLW_BIAS2_B_+				37	58
PLW_BIAS2_B_-				18	46
PLW_BIAS2_B_shld				19 (C4)	91 (C4)
PLW_GROUND_WIRE_B				19 (C4)	91 (C4)
Harness Over-shield	EMC Backshell	EMC Backshell	EMC Backshell	EMC Backshell	EMC Backshell

FPU Faraday Shield Link Pins												
2	3	4	5	7	8	15	25	47	65	82	93	94
105	114	115	121	122	123	124	125	126	127	X	X	X



SPIRE HARNESS DEFINITION DOCUMENT

Doc: SPIRE-RAL-PRJ-000608
Issue: 1.2
Date: 17/02/05
Page 137 of 245

4.4.4 C4 CVV4 to HSJFP Type1

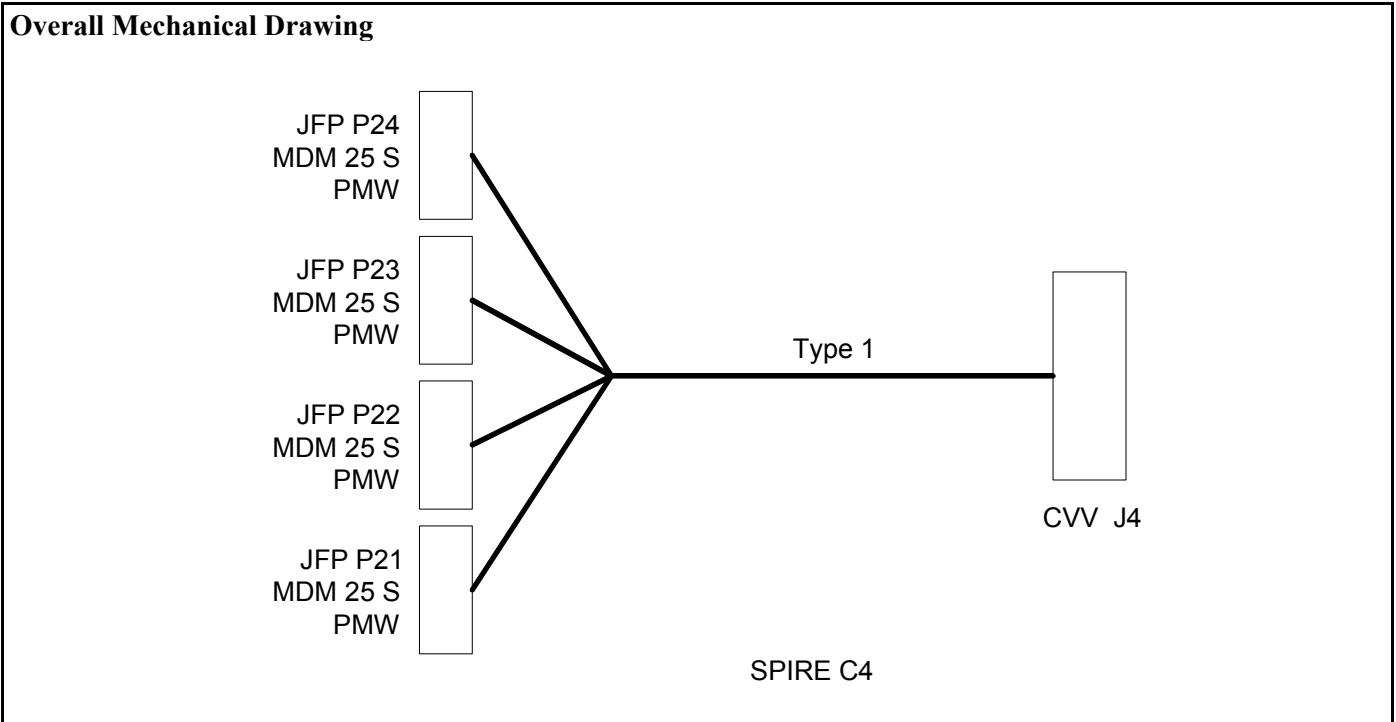

Connector Backshell Details

MDM 25 S	+	Glenair	507	-	T	-	196	-	M	-	37	to	JFPJ21	PMW Signals
MDM 25 S	+	Glenair	507	-	T	-	196	-	M	-	37	to	JFPJ22	PMW Signals
MDM 25 S	+	Glenair	507	-	T	-	196	-	M	-	37	to	JFPJ23	PMW Signals
MDM 25 S	+	Glenair	507	-	T	-	196	-	M	-	37	to	JFPJ24	PMW Signals



SPIRE HARNESS DEFINITION DOCUMENT

Doc: SPIRE-RAL-PRJ-000608

Issue: 1.2

Date: 17/02/05

Page 138 of 245

Harness Layup

The total harness layup is as follows:

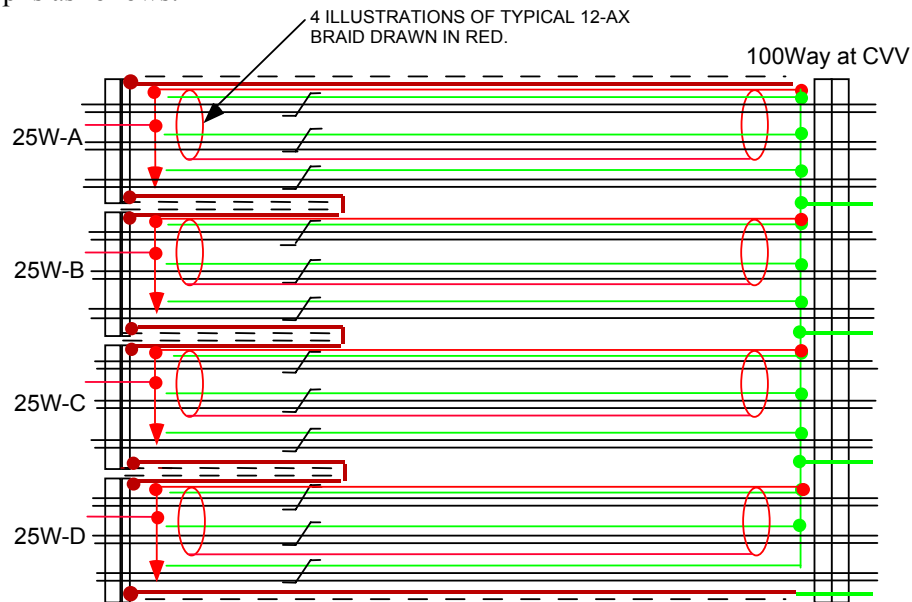

There are 48 channels each carried as a twisted triple, grouped in fours as "12-ax", each with its own insulated screen. So are 12 x 12-ax in all with three 12-ax to each 25 way MDM. The use of a third wire twisted with each channel's + & - wires minimises interchannel cross-talk inside each 12-

As for the intermediate harness, 4 pins carry ground through the 100 way and carry an isolated ground ring. All the third are made off to this, as are all the 12-ax

At the 25way MDMs, the three 12-ax braids (which have a much higher conductivity than that of the sum of all the third wires) are joined to the third wires and passed through the one non-signal

To keep RF screening distinct from low noise bolometer grounds, all of this harness is enclosed in separate outer r.f. screen, sealed to connector boots at the JFET end, overwrapped with insulation, and carried on a pin at the 100

Any one MDM tail, as drawn for the other harnesses, looks like: -

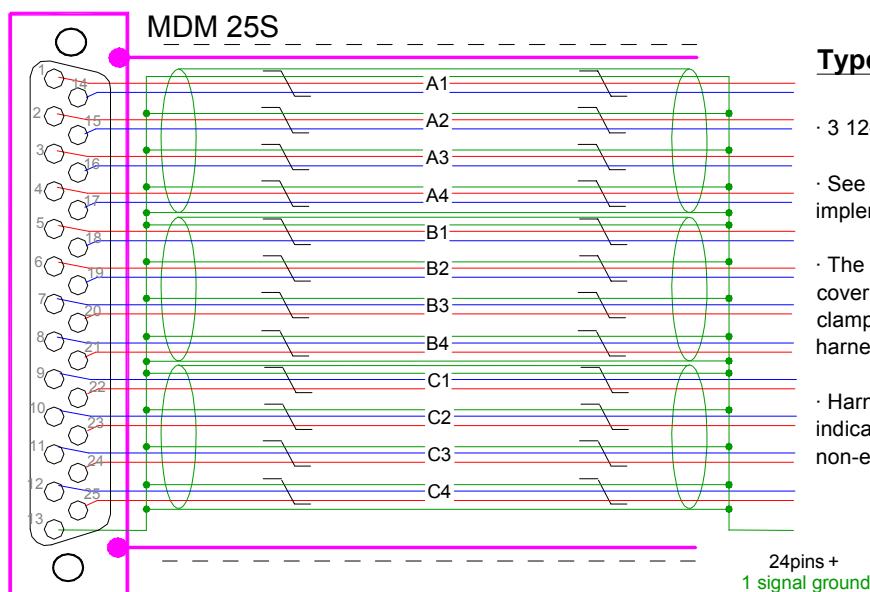

Type 1 JFET Tails

- 3 12-ax
- See Section 4.3 for details regarding the implementation of the shields.
- The dotted lines indicate insulation jacket covering the overshield. Only required at clamp points but could cover entire length of harness.
- Harness connector is a Socket. Drawing indicates pin allocation as seen from the rear, non-engaging face of the connector.



SPIRE HARNESS DEFINITION DOCUMENT

Doc: SPIRE-RAL-PRJ-000608

Issue: 1.2

Date: 17/02/05

Page 139 of 245

CVV C4 128-Way Pin Allocations (View of wiring side of connector)

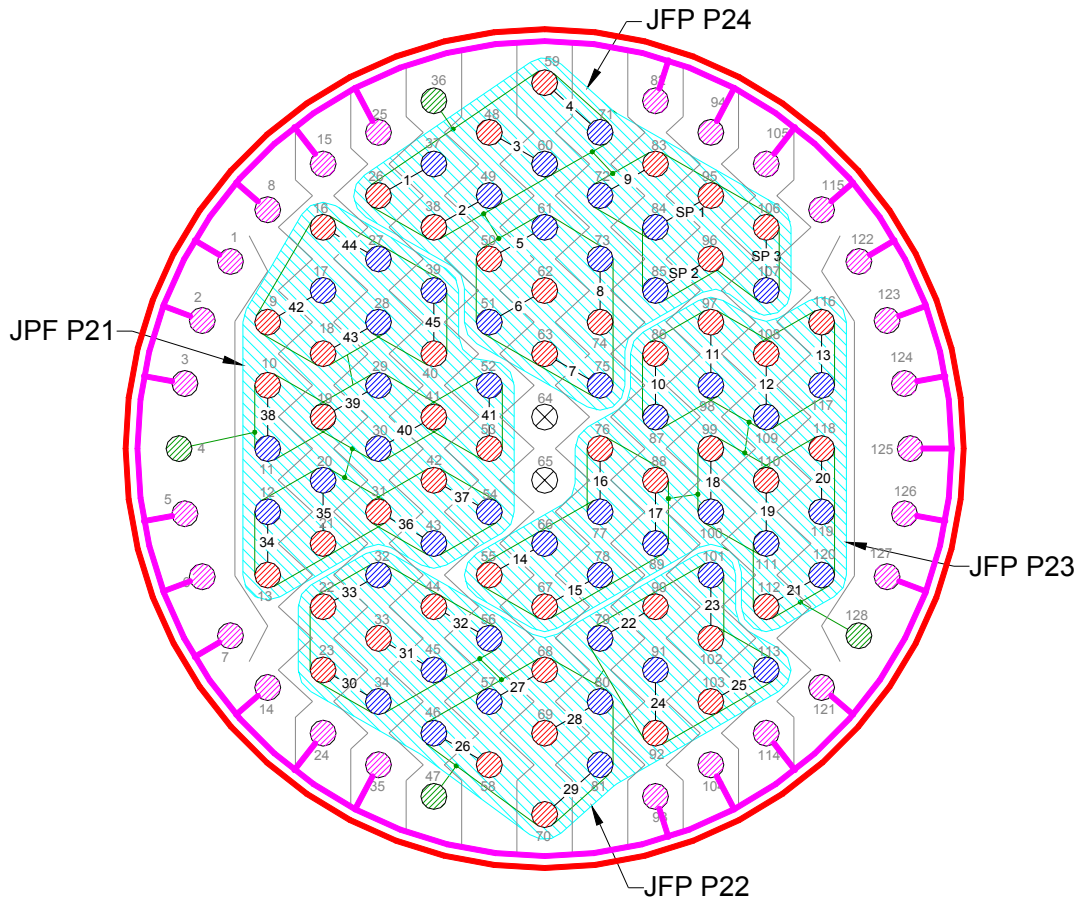

- Signal Supply Pin
- Signal Return Pin
- Signal Ground Pin
- FPU Faraday Shield Link Pin
- No Connection
- Harness Tails
- Connector Chassis (isolated from FPU Faraday Shield)
- FPU Faraday Shield (i.e. Harness overshield - isolated from S/C structure)
- Ground Plane Interconnection

- Shields of 12-ax are commoned as indicated by signal ground connections and passed through the 128-way by a dedicated ground pin.
- Three Spare channels from JFP P24 labelled as SP 1, SP 2 and SP 3 are terminated open on the cold side of the connector.

Table 4.4-4 - SIH-CS-04 Listing

	Name	Pixel	JFP P24	JFP P23	JFP P22	JFP P21	12Way #4
C4-12ax-A	Channel 1 +	PMW-F10	1				26
	Channel 1 -		14				37
	Channel 1gnd		13 (A1)				36 (A1)
	Channel 2 +	PMW-E11	2				38
	Channel 2 -		15				49
	Channel 2gnd		13 (A1)				36 (A1)
	Channel 3 +	PMW-G11	3				48
	Channel 3 -		16				60
	Channel 3gnd		13 (A1)				36 (A1)
	Channel 4 +	PMW-F11	4				59
Channel 4 -	17					71	
Channel 4gnd	13 (A1)					36 (A1)	
C4-12ax-B	Channel 5 +	PMW-E12	5				50
	Channel 5 -		18				61
	Channel 5gnd		13 (A1)				36 (A1)
	Channel 6 +	PMW-G12	6				62
	Channel 6 -		19				51
	Channel 6gnd		13 (A1)				36 (A1)
	Channel 7 +	PMW-F12	20				63
	Channel 7 -		7				75
	Channel 7gnd		13 (A1)				36 (A1)
	Channel 8 +	PMW-G13	21				74
Channel 8 -	8					73	
Channel 8gnd	13 (A1)					36 (A1)	
C4-12ax-C	Channel 9 +	PMW-DK2	22				83
	Channel 9 -		9				72
	Channel 9gnd		13 (A1)				36 (A1)
	Channel 10 +	SPARE	23				95
	Channel 10 -		10				84
	Channel 10gnd		13 (A1)				36 (A1)
	Channel 11 +	SPARE	24				96
	Channel 11 -		11				85
	Channel 11gnd		13 (A1)				36 (A1)
	Channel 12 +	SPARE	25				106
Channel 12 -	12					107	
Channel 12gnd	13 (A1)					36 (A1)	
C4-12ax-D	Channel 13 +	PMW-E7		1			86
	Channel 13 -			14			87
	Channel 13gnd			13 (A2)			128 (A2)
	Channel 14 +	PMW-D7		2			97
	Channel 14 -			15			98
	Channel 14gnd			13 (A2)			128 (A2)
	Channel 15 +	PMW-F7		3			108
	Channel 15 -			16			109
	Channel 15gnd			13 (A2)			128 (A2)
	Channel 16 +	PMW-E8		4			116
Channel 16 -			17			117	
Channel 16gnd			13 (A2)			128 (A2)	
C4-12ax-E	Channel 17 +	PMW-G8		5			55
	Channel 17 -			18			66
	Channel 17gnd			13 (A2)			128 (A2)
	Channel 18 +	PMW-F8		6			67
	Channel 18 -			19			78
	Channel 18gnd			13 (A2)			128 (A2)
	Channel 19 +	PMW-E9		20			76
	Channel 19 -			7			77
	Channel 19gnd			13 (A2)			128 (A2)
	Channel 20 +	PMW-G9		21			88
Channel 20 -			8			89	
Channel 20gnd			13 (A2)			128 (A2)	
C4-12ax-F	Channel 21 +	PMW-D9		22			99
	Channel 21 -			9			100
	Channel 21gnd			13 (A2)			128 (A2)
	Channel 22 +	PMW-F9		23			110
	Channel 22 -			10			111
	Channel 22gnd			13 (A2)			128 (A2)
Channel 23 +	PMW-E10		24			118	



SPIRE HARNESS DEFINITION DOCUMENT

Doc: SPIRE-RAL-PRJ-000608
Issue: 1.2
Date: 17/02/05
Page 141 of 245

	Name	Pixel	JFP P24	JFP P23	JFP P22	JFP P21	12Way #4	
	Channel 23 -	PMW-G10		11			119	
	Channel 23gnd			13 (A2)			128 (A2)	
	Channel 24 +			25			112	
	Channel 24 -			12			120	
	Channel 24gnd			13 (A2)			128 (A2)	
C4-12ax-G	Channel 25 +	PMW-C4			1		90	
	Channel 25 -			14		79		
	Channel 25gnd			13 (A3)		47 (A3)		
	Channel 26 +	PMW-B3			2		102	
	Channel 26 -			15		101		
	Channel 26gnd			13 (A3)		47 (A3)		
	Channel 27 +	PMW-C3			3		92	
	Channel 27 -			16		91		
	Channel 27gnd			13 (A3)		47 (A3)		
	Channel 28 +	PMW-B2			4		103	
	Channel 28 -			17		113		
	Channel 28gnd			13 (A3)		47 (A3)		
	C4-12ax-H	Channel 29 +	PMW-D2			5		58
		Channel 29 -			18		46	
Channel 29gnd				13 (A3)		47 (A3)		
Channel 30 +		PMW-A3			6		68	
Channel 30 -				19		57		
Channel 30gnd				13 (A3)		47 (A3)		
Channel 31 +		PMW-A2			20		69	
Channel 31 -				7		80		
Channel 31gnd				13 (A3)		47 (A3)		
Channel 32 +		PMW-C2			21		70	
Channel 32 -				8		81		
Channel 32gnd				13 (A3)		47 (A3)		
C4-12ax-I		Channel 33 +	PMW-B1			22		23
		Channel 33 -			9		34	
	Channel 33gnd			13 (A3)		47 (A3)		
	Channel 34 +	PMW-A1			23		33	
	Channel 34 -			10		45		
	Channel 34gnd			13 (A3)		47 (A3)		
	Channel 35 +	PMW-DK1			24		44	
	Channel 35 -			11		56		
	Channel 35gnd			13 (A3)		47 (A3)		
	Channel 36 +	PMW-C1			25		22	
	Channel 36 -			12		32		
	Channel 36gnd			13 (A3)		47 (A3)		
	C4-12ax-J	Channel 37 +	PMW-A7				1	13
		Channel 37 -				14	12	
Channel 37gnd					13 (A4)	4 (A4)		
Channel 38 +		PMW-A6				2	21	
Channel 38 -					15	20		
Channel 38gnd					13 (A4)	4 (A4)		
Channel 39 +		PMW-B6				3	31	
Channel 39 -					16	43		
Channel 39gnd					13 (A4)	4 (A4)		
Channel 40 +		PMW-C7				4	42	
Channel 40 -					17	54		
Channel 40gnd					13 (A4)	4 (A4)		
C4-12ax-K		Channel 41 +	PMW-A5				5	10
		Channel 41 -				18	11	
	Channel 41gnd				13 (A4)	4 (A4)		
	Channel 42 +	PMW-B5				6	19	
	Channel 42 -				19	29		
	Channel 42gnd				13 (A4)	4 (A4)		
	Channel 43 +	PMW-C6				20	41	
	Channel 43 -				7	30		
	Channel 43gnd				13 (A4)	4 (A4)		
	Channel 44 +	PMW-D6				21	53	
	Channel 44 -				8	52		
	Channel 44gnd				13 (A4)	4 (A4)		
	C4-12ax-L	Channel 45 +	PMW-B4				22	9
		Channel 45 -				9	17	
Channel 45gnd					13 (A4)	4 (A4)		
Channel 46 +		PMW-C5				23	18	
Channel 46 -					10	28		
	Channel 46gnd				13 (A4)	4 (A4)		



SPIRE HARNESS DEFINITION DOCUMENT

Doc: SPIRE-RAL-PRJ-000608
Issue: 1.2
Date: 17/02/05
Page 142 of 245

Name	Pixel	JFP P24	JFP P23	JFP P22	JFP P21	12Way #4
Channel 47 +	PMW-D4				24	16
Channel 47 -					11	27
Channel 47gnd					13 (A4)	4 (A4)
Channel 48 +	PMW-A4				25	40
Channel 48 -					12	39
Channel 48gnd					13 (A4)	4 (A4)
Harness Overshield		EMC Backshell	EMC Backshell	EMC Backshell	EMC Backshell	

FPU Faraday Shield Link Pins												
1	2	3	5	6	7	8	14	15	24	25	35	82
93	94	104	105	114	115	121	122	123	124	125	126	127

4.4.5 C5 CVV5 to HSJFP Type1

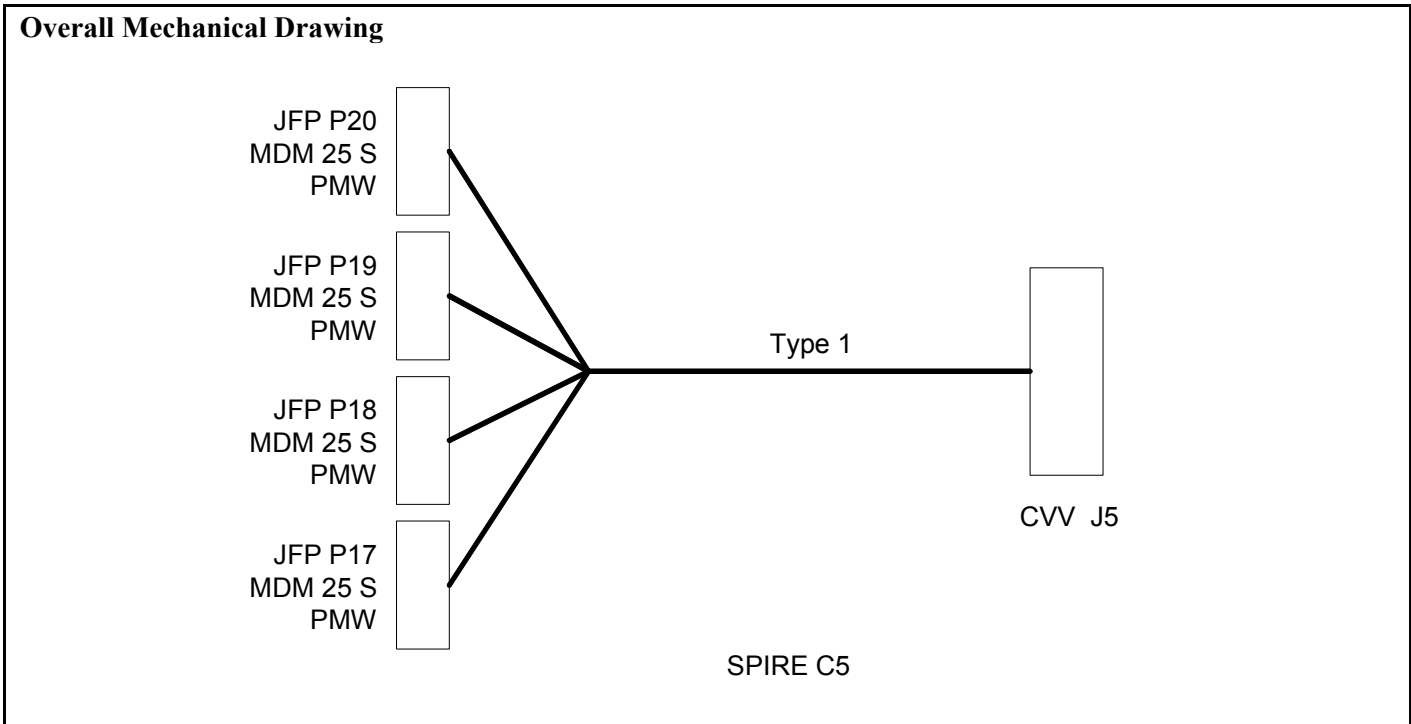

Connector/Backshell Details

MDM25S+Glenair507-T-196-M-37 to	JFPJ17	PMW Signals
MDM25S+Glenair507-T-196-M-37 to	JFPJ18	PMW Signals
MDM25S+Glenair507-T-196-M-37 to	JFPJ19	PMW Signals
MDM25S+Glenair507-T-196-M-37 to	JFPJ20	PMW Signals

Harness Layup

Four Tails as per C4



SPIRE HARNESS DEFINITION DOCUMENT

Doc: SPIRE-RAL-PRJ-000608

Issue: 1.2

Date: 17/02/05

Page 144 of 245

CVV C5 128-Way Pin Allocations (View of wiring side of connector)

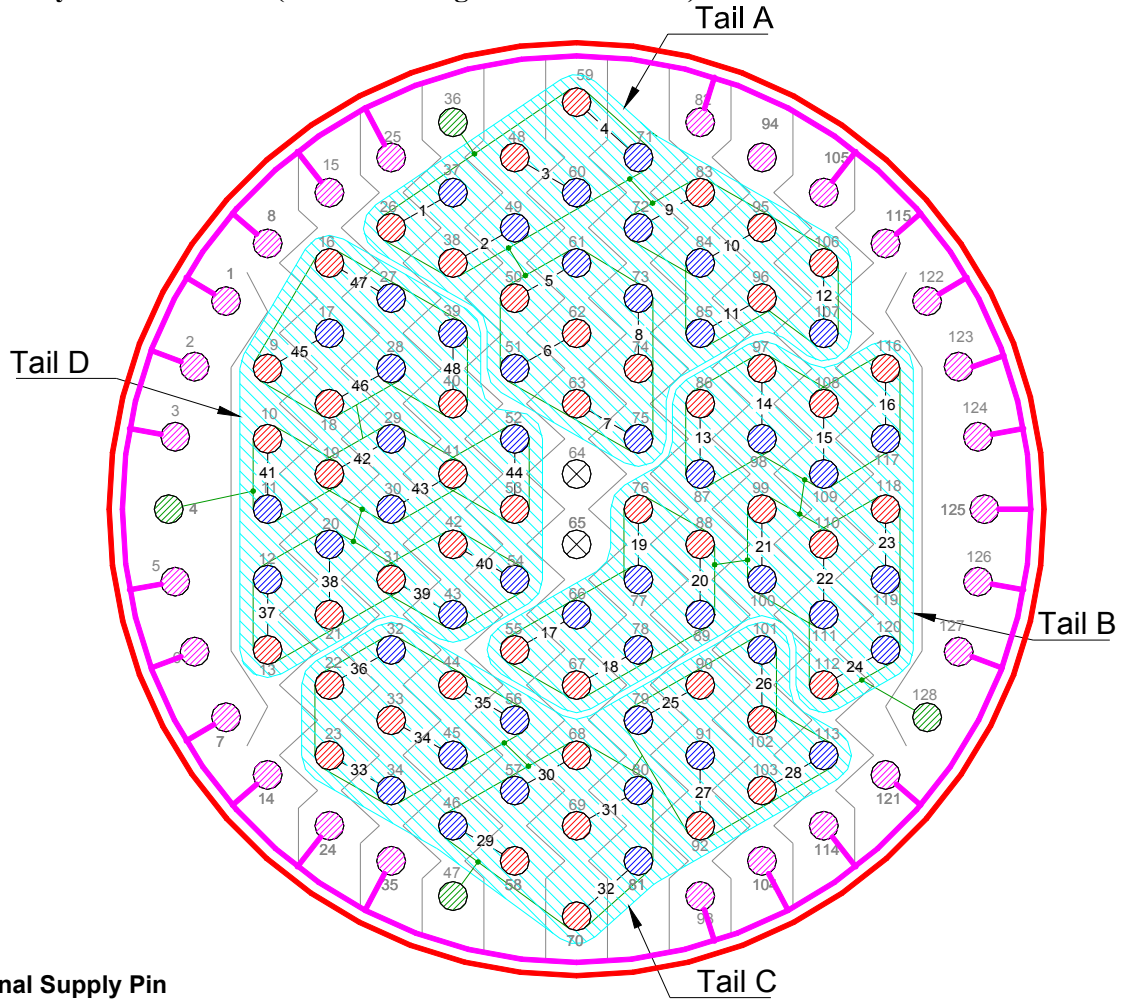

- Signal Supply Pin**
- Signal Return Pin**
- Signal Ground Pin**
- FPU Faraday Shield Link Pin**
- No Connection**
- Harness Tails**
- Connector Chassis (isolated from FPU Faraday Shield)**
- FPU Faraday Shield (i.e. Harness overshield - isolated from S/C structure)**
- Ground Plane Interconnection**

- Shields of 12-ax are commoned as indicated by signal ground connections and passed through the 128-way by a dedicated ground pin.



SPIRE HARNESS DEFINITION DOCUMENT

Doc: SPIRE-RAL-PRJ-000608
Issue: 1.2
Date: 17/02/05
Page 145 of 245

Contact Details

Table 4.4-5 - SIH-CS-05 Listing

	Name		JFP P17 (25way A)	JFP P18 (25wayB)	JFP P19 (25Way C)	JFP P20 (25way D)	128Way #5
C5-12ax-A	Channel 1 +	PMW-A13	1				26
	Channel 1 -		14				37
	Channel 1gnd		13 (A1)				36 (A1)
	Channel 2 +	PMW-T1	2				38
	Channel 2 -		15				49
	Channel 2gnd		13 (A1)				36 (A1)
	Channel 3 +	PMW-B12	3				48
	Channel 3 -		16				60
	Channel 3gnd		13 (A1)				36 (A1)
	Channel 4 +	PMW-C13	4				59
	Channel 4 -		17				71
	Channel 4gnd		13 (A1)				36 (A1)
C5-12ax-B	Channel 5 +	PMW-A12	5				50
	Channel 5 -		18				61
	Channel 5gnd		13 (A1)				36 (A1)
	Channel 6 +	PMW-D12	6				62
	Channel 6 -		19				51
	Channel 6gnd		13 (A1)				36 (A1)
	Channel 7 +	PMW-C12	20				63
	Channel 7 -		7				75
	Channel 7gnd		13 (A1)				36 (A1)
	Channel 8 +	PMW-B11	21				74
	Channel 8 -		8				73
	Channel 8gnd		13 (A1)				36 (A1)
C5-12ax-C	Channel 9 +	PMW-A11	22				83
	Channel 9 -		9				72
	Channel 9gnd		13 (A1)				36 (A1)
	Channel 10 +	PMW-A13	23				95
	Channel 10 -		10				84
	Channel 10gnd		13 (A1)				36 (A1)
	Channel 11 +	PMW-D11	24				96
	Channel 11 -		11				85
	Channel 11gnd		13 (A1)				36 (A1)
	Channel 12 +	PMW-C11	25				106
	Channel 12 -		12				107
	Channel 12gnd		13 (A1)				36 (A1)
C5-12ax-D	Channel 13 +	PMW-B10		1			86
	Channel 13 -			14			87
	Channel 13gnd			13 (A2)			128 (A2)
	Channel 14 +	PMW-A10		2			97
	Channel 14 -			15			98
	Channel 1gnd			13 (A2)			128 (A2)
	Channel 15 +	PMW-D10		3			108
	Channel 15 -			16			109
	Channel 15gnd			13 (A2)			128 (A2)
	Channel 16 +	PMW-B9		4			116
	Channel 16 -			17			117
	Channel 16gnd			13 (A2)			128 (A2)
C5-12ax-E	Channel 17 +	PMW-C10		5			55
	Channel 17 -			18			66
	Channel 17gnd			13 (A2)			128 (A2)
	Channel 18 +	PMW-C9		6			67
	Channel 18 -			19			78
	Channel 18gnd			13 (A2)			128 (A2)
	Channel 19 +	PMW-A9		20			76
	Channel 19 -			7			77
	Channel 19gnd			13 (A2)			128 (A2)
	Channel 20 +	PMW-B8		21			88
	Channel 20 -			8			89
	Channel 20gnd			13 (A2)			128 (A2)
C5-12ax-F	Channel 21 +	PMW-A8		22			99
	Channel 21 -			9			100
	Channel 21gnd			13 (A2)			128 (A2)
	Channel 22 +	PMW-D8		23			110
Channel 22 -			10			111	



SPIRE HARNESS DEFINITION DOCUMENT

Doc: SPIRE-RAL-PRJ-000608
Issue: 1.2
Date: 17/02/05
Page 146 of 245

	Name		JFP P17 (25way A)	JFP P18 (25wayB)	JFP P19 (25Way C)	JFP P20 (25way D)	128Way #5
	Channel 22gnd			13 (A2)			128 (A2)
	Channel 23 +	PMW-C8		24			118
	Channel 23 -			11			119
	Channel 23gnd			13 (A2)			128 (A2)
	Channel 24 +	PMW-B7		25			112
	Channel 24 -			12			120
Channel 24gnd			13 (A2)			128 (A2)	
C5-12ax-G	Channel 25 +	PMW-R1			1		90
	Channel 25 -			14		79	
	Channel 25gnd			13 (A3)		47 (A3)	
	Channel 26 +	PMW-G1			2		102
	Channel 26 -			15		101	
	Channel 26gnd			13 (A3)		47 (A3)	
	Channel 27 +	PMW-T2			3		92
	Channel 27 -			16		91	
	Channel 27gnd			13 (A3)		47 (A3)	
	Channel 28 +	PMW-E1			4		103
	Channel 28 -			17		113	
	Channel 28gnd			13 (A3)		47 (A3)	
C5-12ax-H	Channel 29 +	PMW-D1			5		58
	Channel 29 -			18		46	
	Channel 29gnd			13 (A3)		47 (A3)	
	Channel 30 +	PMW-F1			6		68
	Channel 30 -			19		57	
	Channel 30gnd			13 (A3)		47 (A3)	
	Channel 31 +	PMW-E2			20		69
	Channel 31 -			7		80	
	Channel 31gnd			13 (A3)		47 (A3)	
	Channel 32 +	PMW-G2			21		70
Channel 32 -			8		81		
Channel 32gnd			13 (A3)		47 (A3)		
C5-12ax-I	Channel 33 +	PMW-F2			22		23
	Channel 33 -			9		34	
	Channel 33gnd			13 (A3)		47 (A3)	
	Channel 34 +	PMW-G3			23		33
	Channel 34 -			10		45	
	Channel 34gnd			13 (A3)		47 (A3)	
	Channel 35 +	PMW-E3			24		44
	Channel 35 -			11		56	
	Channel 35gnd			13 (A3)		47 (A3)	
	Channel 36 +	PMW-D3			25		22
Channel 36 -			12		32		
Channel 36gnd			13 (A3)		47 (A3)		
C5-12ax-J	Channel 37 +	PMW-F3				1	13
	Channel 37 -				14	12	
	Channel 37gnd				13 (A4)	4 (A4)	
	Channel 38 +	PMW-G4			2		21
	Channel 38 -				15	20	
	Channel 38gnd				13 (A4)	4 (A4)	
	Channel 39 +	PMW-E4			3		31
	Channel 39 -				16	43	
	Channel 39gnd				13 (A4)	4 (A4)	
	Channel 40 +	PMW-F4			4		42
Channel 40 -				17	54		
Channel 40gnd				13 (A4)	4 (A4)		
C5-12ax-K	Channel 41 +	PMW-E5			5		10
	Channel 41 -				18	11	
	Channel 41gnd				13 (A4)	4 (A4)	
	Channel 42 +	PMW-D5			6		19
	Channel 42 -				19	29	
	Channel 42gnd				13 (A4)	4 (A4)	
	Channel 43 +	PMW-F5			20		41
	Channel 43 -				7	30	
	Channel 43gnd				13 (A4)	4 (A4)	
	Channel 44 +	PMW-G5			21		53
Channel 44 -				8	52		
Channel 44gnd				13 (A4)	4 (A4)		
C5-12ax-L	Channel 45 +	PMW-E6			22		9
	Channel 45 -				9	17	
	Channel 45gnd				13 (A4)	4 (A4)	



SPIRE HARNESS DEFINITION DOCUMENT

Doc: SPIRE-RAL-PRJ-000608
Issue: 1.2
Date: 17/02/05
Page 147 of 245

Name		JFP P17 (25way A)	JFP P18 (25wayB)	JFP P19 (25Way C)	JFP P20 (25way D)	128Way #5
Channel 46 +	PMW-G6				23	18
Channel 46 -					10	28
Channel 46gnd					13 (A4)	4 (A4)
Channel 47 +	PMW-F6				24	16
Channel 47 -					11	27
Channel 47gnd					13 (A4)	4 (A4)
Channel 48 +	PMW-G7				25	40
Channel 48 -					12	39
Channel 48gnd					13 (A4)	4 (A4)
Harness Overshield		EMC Backshell	EMC Backshell	EMC Backshell	EMC Backshell	

FPU Faraday Shield Link Pins												
1	2	3	5	6	7	8	14	15	24	25	35	82
93	94	104	105	114	115	121	122	123	124	125	126	127



SPIRE HARNESS DEFINITION DOCUMENT

Doc: SPIRE-RAL-PRJ-000608
Issue: 1.2
Date: 17/02/05
Page 148 of 245

4.4.6 C6 CVV6 to HSJFP Type1

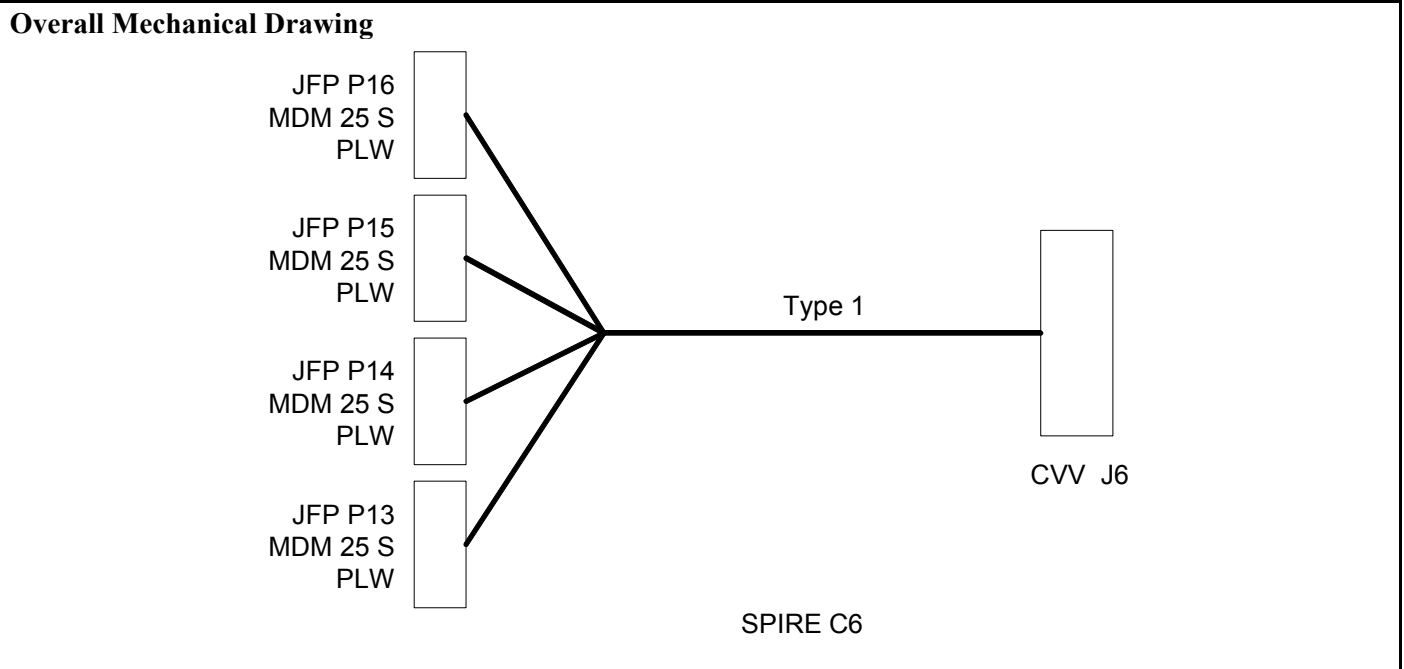

Connector/Backshell Details

MDM25S+Glenair507-T-196-M-37 to	JFPJ13	PLW Signals
MDM25S+Glenair507-T-196-M-37 to	JFPJ14	PLW Signals
MDM25S+Glenair507-T-196-M-37 to	JFPJ15	PLW Signals
MDM25S+Glenair507-T-196-M-37 to	JFPJ16	PLW Signals

Harness Layup

As C4.

Contact Details

As C4.

Table 4.4-6 - SIH-CS-06 Listing

	Name	Pixel	JFP P13	JFP P14	JFP P15	JFP P16	128Way #6
C6-12ax-A	Channel 1 +	PLW-R1	1				26
	Channel 1 -		14				37
	Channel 1gnd		13 (A1)				36 (A1)
	Channel 2 +	PLW-A8	2				38
	Channel 2 -		15				49
	Channel 2gnd		13 (A1)				36 (A1)
	Channel 3 +	PLW-A7	3				48
	Channel 3 -		16				60
	Channel 3gnd		13 (A1)				36 (A1)
	Channel 4 +	PLW-A6	4				59
	Channel 4 -		17				71
	Channel 4gnd		13 (A1)				36 (A1)
C6-12ax-B	Channel 5 +	PLW-A9	5				50
	Channel 5 -		18				61
	Channel 5gnd		13 (A1)				36 (A1)
	Channel 6 +	PLW-C9	6				62
	Channel 6 -		19				51



SPIRE HARNESS DEFINITION DOCUMENT

Doc: SPIRE-RAL-PRJ-000608
Issue: 1.2
Date: 17/02/05
Page 149 of 245

	Name	Pixel	JFP P13	JFP P14	JFP P15	JFP P16	128Way #6
	Channel 6gnd		13 (A1)				36 (A1)
	Channel 7 +	PLW-B8	20				63
	Channel 7 -		7				75
	Channel 7gnd		13 (A1)				36 (A1)
	Channel 8 +	PLW-B7	21				74
	Channel 8 -		8				73
Channel 8gnd	13 (A1)					36 (A1)	
C6-12ax-C	Channel 9 +	PLW-C7	22				83
	Channel 9 -		9			72	
	Channel 9gnd		13 (A1)			36 (A1)	
	Channel 10 +	PLW-B5	23				95
	Channel 10 -		10			84	
	Channel 10gnd		13 (A1)			36 (A1)	
	Channel 11 +	PLW-B6	24				96
	Channel 11 -		11			85	
	Channel 11gnd		13 (A1)			36 (A1)	
	Channel 12 +	PLW-A5	25				106
Channel 12 -	12				107		
Channel 12gnd	13 (A1)				36 (A1)		
C6-12ax-D	Channel 13 +	PLW-T1		1			86
	Channel 13 -			14		87	
	Channel 13gnd			13 (A2)		128 (A2)	
	Channel 14 +	PLW-B4		2			97
	Channel 14 -			15		98	
	Channel 14gnd			13 (A2)		128 (A2)	
	Channel 15 +	PLW-C4		3			108
	Channel 15 -			16		109	
	Channel 15gnd			13 (A2)		128 (A2)	
	Channel 16 +	PLW-B3		4			116
Channel 16 -			17		117		
Channel 16gnd			13 (A2)		128 (A2)		
C6-12ax-E	Channel 17 +	PLW-C2		5			55
	Channel 17 -			18		66	
	Channel 17gnd			13 (A2)		128 (A2)	
	Channel 18 +	PLW-B2		6			67
	Channel 18 -			19		78	
	Channel 18gnd			13 (A2)		128 (A2)	
	Channel 19 +	PLW-B1		20			76
	Channel 19 -			7		77	
	Channel 19gnd			13 (A2)		128 (A2)	
	Channel 20 +	PLW-A3		21			88
Channel 20 -			8		89		
Channel 20gnd			13 (A2)		128 (A2)		
C6-12ax-F	Channel 21 +	PLW-A4		22			99
	Channel 21 -			9		100	
	Channel 21gnd			13 (A2)		128 (A2)	
	Channel 22 +	PLW-A1		23			110
	Channel 22 -			10		111	
	Channel 22gnd			13 (A2)		128 (A2)	
	Channel 23 +	PLW-DK1		24			118
	Channel 23 -			11		119	
	Channel 23gnd			13 (A2)		128 (A2)	
	Channel 24 +	PLW-A2		25			112
Channel 24 -			12		120		
Channel 24gnd			13 (A2)		128 (A2)		
C6-12ax-G	Channel 25 +	PLW-E1			1		90
	Channel 25 -				14		79
	Channel 25gnd				13 (A3)		47 (A3)
	Channel 26 +	PLW-E2			2		102
	Channel 26 -				15		101
	Channel 26gnd				13 (A3)		47 (A3)
	Channel 27 +	PLW-E3			3		92
	Channel 27 -				16		91
	Channel 27gnd				13 (A3)		47 (A3)
	Channel 28 +	PLW-E4			4		103
Channel 28 -				17		113	
Channel 28gnd				13 (A3)		47 (A3)	
C6-12ax-H	Channel 29 +	PLW-D1			5		58
	Channel 29 -				18		46
	Channel 29gnd				13 (A3)		47 (A3)
	Channel 30 +		PLW-D2			6	



SPIRE HARNESS DEFINITION DOCUMENT

Doc: SPIRE-RAL-PRJ-000608
Issue: 1.2
Date: 17/02/05
Page 150 of 245

	Name	Pixel	JFP P13	JFP P14	JFP P15	JFP P16	128Way #6
	Channel 30 -	PLW-D3			19		57
	Channel 30gnd				13 (A3)		47 (A3)
	Channel 31 +				20		69
	Channel 31 -	PLW-D4			7		80
	Channel 31gnd				13 (A3)		47 (A3)
	Channel 32 +				21		70
	Channel 32 -				8		81
Channel 32gnd	PLW-C1			13 (A3)		47 (A3)	
Channel 33 +				22		23	
Channel 33 -				9		34	
Channel 33gnd	PLW-C3			13 (A3)		47 (A3)	
Channel 34 +				23		33	
Channel 34 -				10		45	
Channel 34gnd	PLW-C5			13 (A3)		47 (A3)	
Channel 35 +				24		44	
Channel 35 -				11		56	
Channel 35gnd	PLW-T2			13 (A3)		47 (A3)	
Channel 36 +				25		22	
Channel 36 -				12		32	
Channel 36gnd	PLW-E5			13 (A3)		47 (A3)	
Channel 37 +					1	13	
Channel 37 -					14	12	
Channel 37gnd	PLW-C6				13 (A4)	4 (A4)	
Channel 38 +					2	21	
Channel 38 -					15	20	
Channel 38gnd	PLW-C8				13 (A4)	4 (A4)	
Channel 39 +					3	31	
Channel 39 -					16	43	
Channel 39gnd	PLW-D5				13 (A4)	4 (A4)	
Channel 40 +					4	42	
Channel 40 -					17	54	
Channel 40gnd	PLW-D6				13 (A4)	4 (A4)	
Channel 41 +					5	10	
Channel 41 -					18	11	
Channel 41gnd	PLW-D7				13 (A4)	4 (A4)	
Channel 42 +					6	19	
Channel 42 -					19	29	
Channel 42gnd	PLW-D8				13 (A4)	4 (A4)	
Channel 43 +					20	41	
Channel 43 -					7	30	
Channel 43gnd	PLW-E7				13 (A4)	4 (A4)	
Channel 44 +					21	53	
Channel 44 -					8	52	
Channel 44gnd	PLW-E6				13 (A4)	4 (A4)	
Channel 45 +					22	9	
Channel 45 -					9	17	
Channel 45gnd	PLW-E8				13 (A4)	4 (A4)	
Channel 46 +					23	18	
Channel 46 -					10	28	
Channel 46gnd	PLW-DK2				13 (A4)	4 (A4)	
Channel 47 +					24	16	
Channel 47 -					11	27	
Channel 47gnd	PLW-E9				13 (A4)	4 (A4)	
Channel 48 +					25	40	
Channel 48 -					12	39	
Channel 48gnd					13 (A4)	4 (A4)	
	Harness Overshield		EMC Backshell	EMC Backshell	EMC Backshell	EMC Backshell	EMC Backshell

FPU Faraday Shield Link Pins												
1	2	3	5	6	7	8	14	15	24	25	35	82
93	94	104	105	114	115	121	122	123	124	125	126	127



SPIRE HARNESS DEFINITION DOCUMENT

Doc: SPIRE-RAL-PRJ-000608
Issue: 1.2
Date: 17/02/05
Page 151 of 245

4.4.7 C7 CVV7 to HSJFP Type1

Overall Mechanical Drawing

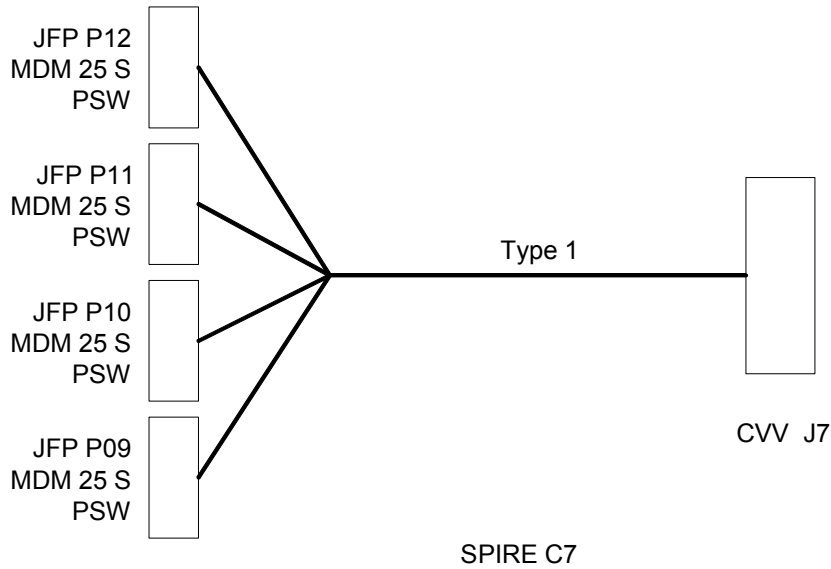

Connector/Backshell Details

MDM25S+Glenair507-T-196-M-37 to	JFPJ9	PSW Signals
MDM25S+Glenair507-T-196-M-37 to	JFPJ10	PSW Signals
MDM25S+Glenair507-T-196-M-37 to	JFPJ11	PSW Signals
MDM25S+Glenair507-T-196-M-37 to	JFPJ12	PSW Signals

Harness Layup

As C4.

Contact Details

As C4.

Table 4.4-7 - SIH-CS-07 Listing

	Name	Pixel	JFP P09	JFP P10	JFP P11	JFP P12	128Way #7
C7-12ax-A	Channel 1 +	PSW-D11	1				26
	Channel 1 -		14				37
	Channel 1gnd		13 (A1)				36 (A1)
	Channel 2 +	PSW-A10	2				38
	Channel 2 -		15				49
	Channel 2gnd		13 (A1)				36 (A1)
	Channel 3 +	PSW-E10	3				48
	Channel 3 -		16				60
	Channel 3gnd		13 (A1)				36 (A1)
	Channel 4 +	PSW-C10	4				59
	Channel 4 -		17				71
	Channel 4gnd		13 (A1)				36 (A1)
C7-12ax-B	Channel 5 +	PSW-B10	5				50
	Channel 5 -		18				61
	Channel 5gnd		13 (A1)				36 (A1)
	Channel 6 +	PSW-D10	6				62



SPIRE HARNESS DEFINITION DOCUMENT

Doc: SPIRE-RAL-PRJ-000608
Issue: 1.2
Date: 17/02/05
Page 152 of 245

	Name	Pixel	JFP P09	JFP P10	JFP P11	JFP P12	128Way #7	
	Channel 6 -	PSW-A9	19				51	
	Channel 6gnd		13 (A1)				36 (A1)	
	Channel 7 +		20				63	
	Channel 7 -		7				75	
	Channel 7gnd	13 (A1)				36 (A1)		
	Channel 8 +	PSW-E9	21				74	
	Channel 8 -		8				73	
	Channel 8gnd		13 (A1)				36 (A1)	
C7-12ax-C	Channel 9 +		PSW-C9	22				83
	Channel 9 -	9					72	
	Channel 9gnd	13 (A1)					36 (A1)	
	Channel 10 +	PSW-B9	23				95	
	Channel 10 -		10				84	
	Channel 10gnd		13 (A1)				36 (A1)	
	Channel 11 +	PSW-D9	24				96	
	Channel 11 -		11				85	
	Channel 11gnd		13 (A1)				36 (A1)	
	Channel 12 +		PSW-A8	25				106
	Channel 12 -	12					107	
	Channel 12gnd	13 (A1)					36 (A1)	
	C7-12ax-D	Channel 13 +		PSW-C8		1		
		Channel 13 -			14			87
		Channel 13gnd			13 (A2)			128 (A2)
		Channel 14 +	PSW-E8		2			97
Channel 14 -				15			98	
Channel 14gnd				13 (A2)			128 (A2)	
Channel 15 +		PSW-D8		3			108	
Channel 15 -				16			109	
Channel 15gnd				13 (A2)			128 (A2)	
Channel 16 +			PSW-B8		4			116
Channel 16 -				17			117	
Channel 16gnd				13 (A2)			128 (A2)	
C7-12ax-E	Channel 17 +	PSW-C7			5			55
	Channel 17 -			18			66	
	Channel 17gnd			13 (A2)			128 (A2)	
	Channel 18 +	PSW-E7		6			67	
	Channel 18 -			19			78	
	Channel 18gnd			13 (A2)			128 (A2)	
	Channel 19 +	PSW-A7		20			76	
	Channel 19 -			7			77	
	Channel 19gnd			13 (A2)			128 (A2)	
	Channel 20 +		PSW-D7		21			88
	Channel 20 -			8			89	
	Channel 20gnd			13 (A2)			128 (A2)	
C7-12ax-F	Channel 21 +	PSW-B7			22			99
	Channel 21 -			9			100	
	Channel 21gnd			13 (A2)			128 (A2)	
	Channel 22 +	PSW-C6		23			110	
	Channel 22 -			10			111	
	Channel 22gnd			13 (A2)			128 (A2)	
	Channel 23 +	PSW-E6		24			118	
	Channel 23 -			11			119	
	Channel 23gnd			13 (A2)			128 (A2)	
	Channel 24 +		PSW-A6		25			112
	Channel 24 -			12			120	
	Channel 24gnd			13 (A2)			128 (A2)	
C7-12ax-G	Channel 25 +	PSW-G5				1		90
	Channel 25 -				14		79	
	Channel 25gnd				13 (A3)		47 (A3)	
	Channel 26 +	PSW-H6			2		102	
	Channel 26 -				15		101	
	Channel 26gnd				13 (A3)		47 (A3)	
	Channel 27 +	PSW-J6			3		92	
	Channel 27 -				16		91	
	Channel 27gnd				13 (A3)		47 (A3)	
	Channel 28 +		PSW-F6			4		103
	Channel 28 -				17		113	
	Channel 28gnd				13 (A3)		47 (A3)	
C7-12ax-H	Channel 29 +	PSW-G6				5		58
	Channel 29 -				18		46	
	Channel 29gnd				13 (A3)		47 (A3)	



SPIRE HARNESS DEFINITION DOCUMENT

Doc: SPIRE-RAL-PRJ-000608
Issue: 1.2
Date: 17/02/05
Page 153 of 245

	Name	Pixel	JFP P09	JFP P10	JFP P11	JFP P12	128Way #7
	Channel 30 +	PSW-H7			6		68
	Channel 30 -				19		57
	Channel 30gnd				13 (A3)		47 (A3)
	Channel 31 +	PSW-F7			20		69
	Channel 31 -				7		80
	Channel 31gnd				13 (A3)		47 (A3)
	Channel 32 +	PSW-J7			21		70
	Channel 32 -				8		81
Channel 32gnd				13 (A3)		47 (A3)	
C7-12ax-I	Channel 33 +	PSW-G7			22		23
	Channel 33 -				9		34
	Channel 33gnd				13 (A3)		47 (A3)
	Channel 34 +	PSW-H8			23		33
	Channel 34 -				10		45
	Channel 34gnd				13 (A3)		47 (A3)
	Channel 35 +	PSW-F8			24		44
	Channel 35 -				11		56
	Channel 35gnd				13 (A3)		47 (A3)
	Channel 36 +	PSW-G8			25		22
	Channel 36 -				12		32
	Channel 36gnd				13 (A3)		47 (A3)
C7-12ax-J	Channel 37 +	PSW-J8				1	13
	Channel 37 -					14	12
	Channel 37gnd					13 (A4)	4 (A4)
	Channel 38 +	PSW-F9				2	21
	Channel 38 -					15	20
	Channel 38gnd					13 (A4)	4 (A4)
	Channel 39 +	PSW-H9				3	31
	Channel 39 -					16	43
	Channel 39gnd					13 (A4)	4 (A4)
	Channel 40 +	PSW-G9				4	42
	Channel 40 -					17	54
	Channel 40gnd					13 (A4)	4 (A4)
C7-12ax-K	Channel 41 +	PSW-J9				5	10
	Channel 41 -					18	11
	Channel 41gnd					13 (A4)	4 (A4)
	Channel 42 +	PSW-F10				6	19
	Channel 42 -					19	29
	Channel 42gnd					13 (A4)	4 (A4)
	Channel 43 +	PSW-H10				20	41
	Channel 43 -					7	30
	Channel 43gnd					13 (A4)	4 (A4)
	Channel 44 +	PSW-G10				21	53
	Channel 44 -					8	52
	Channel 44gnd					13 (A4)	4 (A4)
C7-12ax-L	Channel 45 +	PSW-F11				22	9
	Channel 45 -					9	17
	Channel 45gnd					13 (A4)	4 (A4)
	Channel 46 +	PSW-J10				23	18
	Channel 46 -					10	28
	Channel 46gnd					13 (A4)	4 (A4)
	Channel 47 +	PSW-H11				24	16
	Channel 47 -					11	27
	Channel 47gnd					13 (A4)	4 (A4)
	Channel 48 +	PSW-G11				25	40
	Channel 48 -					12	39
	Channel 48gnd					13 (A4)	4 (A4)
	Harness Overshield		EMC Backshell	EMC Backshell	EMC Backshell	EMC Backshell	

FPU Faraday Shield Link Pins													
1	2	3	5	6	7	8	14	15	24	25	35	82	
93	94	104	105	114	115	121	122	123	124	125	126	127	



SPIRE HARNESS DEFINITION DOCUMENT

Doc: SPIRE-RAL-PRJ-000608
Issue: 1.2
Date: 17/02/05
Page 154 of 245

4.4.8 C8 CVV8 to HSJFP Type1

Overall Mechanical Drawing

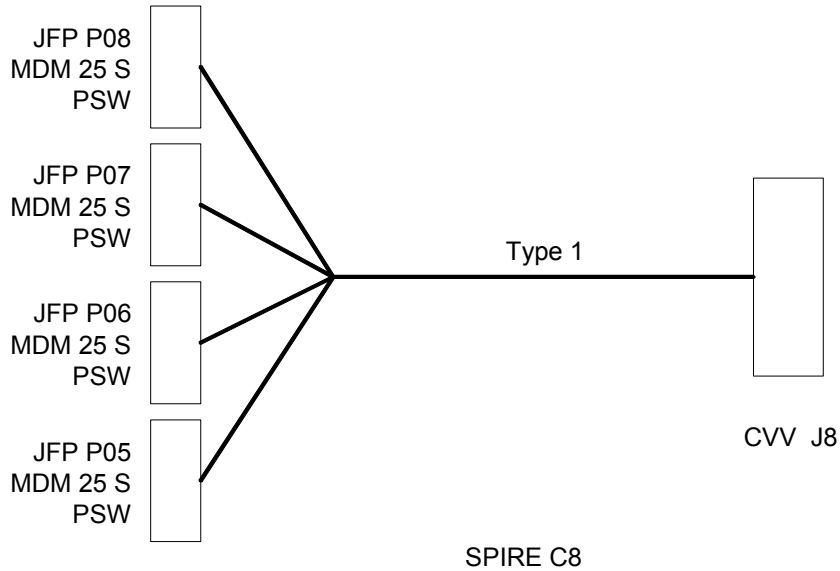

Connector/Backshell Details

MDM25S+Glenair507-T-139-M-37 to	JFPJ5	PSW Signals
MDM25S+Glenair507-T-139-M-37 to	JFPJ6	PSW Signals
MDM25S+Glenair507-T-139-M-37 to	JFPJ7	PSW Signals
MDM25S+Glenair507-T-139-M-37 to	JFPJ8	PSW Signals

Harness Layup

As C4.

Table 4.4-8 - SIH-CS-08 Listing

	Name		JFP P05	JFP P06	JFP P07	JFP P08	128Way #8
C8-12ax-A	Channel 1 +	PSW-D6	1				26
	Channel 1 -		14				37
	Channel 1gnd		13 (A1)				36 (A1)
	Channel 2 +	PSW-B6	2				38
	Channel 2 -		15				49
	Channel 2gnd		13 (A1)				36 (A1)
	Channel 3 +	PSW-C5	3				48
	Channel 3 -		16				60
	Channel 3gnd		13 (A1)				36 (A1)
	Channel 4 +	PSW-A5	4				59
	Channel 4 -		17				71
	Channel 4gnd		13 (A1)				36 (A1)
C8-12ax-B	Channel 5 +	PSW-E5	5				50
	Channel 5 -		18				61
	Channel 5gnd		13 (A1)				36 (A1)
	Channel 6 +	PSW-B5	6				62
	Channel 6 -		19				51
	Channel 6gnd		13 (A1)				36 (A1)
	Channel 7 +	PSW-D5	20				63
	Channel 7 -		7				75
Channel 7gnd	13 (A1)					36 (A1)	
Channel 8 +	PSW-C4	21				74	



SPIRE HARNESS DEFINITION DOCUMENT

Doc: SPIRE-RAL-PRJ-000608
Issue: 1.2
Date: 17/02/05
Page 155 of 245

	Name		JFP P05	JFP P06	JFP P07	JFP P08	128Way #8
	Channel 8 -		8				73
	Channel 8gnd		13 (A1)				36 (A1)
C8-12ax-C	Channel 9 +	PSW-A4	22				83
	Channel 9 -		9				72
	Channel 9gnd		13 (A1)				36 (A1)
	Channel 10 +	PSW-D4	23				95
	Channel 10 -		10				84
	Channel 10gnd		13 (A1)				36 (A1)
	Channel 11 +	PSW-B4	24				96
	Channel 11 -		11				85
	Channel 11gnd		13 (A1)				36 (A1)
	Channel 12 +	PSW-C3	25				106
	Channel 12 -		12				107
	Channel 12gnd		13 (A1)				36 (A1)
C8-12ax-D	Channel 13 +	PSW-B3		1			86
	Channel 13 -			14			87
	Channel 13gnd			13 (A2)			128 (A2)
	Channel 14 +	PSW-A3		2			97
	Channel 14 -			15			98
	Channel 14gnd			13 (A2)			128 (A2)
	Channel 15 +	PSW-A2		3			108
	Channel 15 -			16			109
	Channel 15gnd			13 (A2)			128 (A2)
	Channel 16 +	PSW-D3		4			116
	Channel 16 -			17			117
	Channel 16gnd			13 (A2)			128 (A2)
C8-12ax-E	Channel 17 +	PSW-C2		5			55
	Channel 17 -			18			66
	Channel 17gnd			13 (A2)			128 (A2)
	Channel 18 +	PSW-B2		6			67
	Channel 18 -			19			78
	Channel 18gnd			13 (A2)			128 (A2)
	Channel 19 +	PSW-D2		20			76
	Channel 19 -			7			77
	Channel 19gnd			13 (A2)			128 (A2)
	Channel 20 +	PSW-A1		21			88
	Channel 20 -			8			89
	Channel 20gnd			13 (A2)			128 (A2)
C8-12ax-F	Channel 21 +	PSW-C1		22			99
	Channel 21 -			9			100
	Channel 21gnd			13 (A2)			128 (A2)
	Channel 22 +	PSW-B1		23			110
	Channel 22 -			10			111
	Channel 22gnd			13 (A2)			128 (A2)
	Channel 23 +	PSW-DK1		24			118
	Channel 23 -			11			119
	Channel 23gnd			13 (A2)			128 (A2)
	Channel 24 +	PSW-D1		25			112
	Channel 24 -			12			120
	Channel 24gnd			13 (A2)			128 (A2)
C8-12ax-G	Channel 25 +	PSW-F12			1		90
	Channel 25 -				14		79
	Channel 25gnd				13 (A3)		47 (A3)
	Channel 26 +	PSW-J11			2		102
	Channel 26 -				15		101
	Channel 26gnd				13 (A3)		47 (A3)
	Channel 27 +	PSW-E12			3		92
	Channel 27 -				16		91
	Channel 27gnd				13 (A3)		47 (A3)
	Channel 28 +	PSW-H12			4		103
	Channel 28 -				17		113
	Channel 28gnd				13 (A3)		47 (A3)
C8-12ax-H	Channel 29 +	PSW-G12			5		58
	Channel 29 -				18		46
	Channel 29gnd				13 (A3)		47 (A3)
	Channel 30 +	PSW-F13			6		68
	Channel 30 -				19		57
	Channel 30gnd				13 (A3)		47 (A3)
Channel 31 +	PSW-E13			20		69	
Channel 31 -				7		80	



SPIRE HARNESS DEFINITION DOCUMENT

Doc: SPIRE-RAL-PRJ-000608
Issue: 1.2
Date: 17/02/05
Page 156 of 245

	Name		JFP P05	JFP P06	JFP P07	JFP P08	128Way #8
	Channel 31gnd	PSW-J12			13 (A3)		47 (A3)
	Channel 32 +				21		70
	Channel 32 -				8		81
	Channel 32gnd				13 (A3)		47 (A3)
C8-12ax-I	Channel 33 +	PSW-H13			22		23
	Channel 33 -				9		34
	Channel 33gnd				13 (A3)		47 (A3)
	Channel 34 +	PSW-G13			23		33
	Channel 34 -				10		45
	Channel 34gnd				13 (A3)		47 (A3)
	Channel 35 +	PSW-F14			24		44
	Channel 35 -				11		56
	Channel 35gnd				13 (A3)		47 (A3)
	Channel 36 +	PSW-E14			25		22
	Channel 36 -				12		32
	Channel 36gnd				13 (A3)		47 (A3)
C8-12ax-J	Channel 37 +	PSW-J13				1	13
	Channel 37 -					14	12
	Channel 37gnd					13 (A4)	4 (A4)
	Channel 38 +	PSW-H14				2	21
	Channel 38 -					15	20
	Channel 38gnd					13 (A4)	4 (A4)
	Channel 39 +	PSW-G14				3	31
	Channel 39 -					16	43
	Channel 39gnd					13 (A4)	4 (A4)
	Channel 40 +	PSW-J14				4	42
	Channel 40 -					17	54
	Channel 40gnd					13 (A4)	4 (A4)
C8-12ax-K	Channel 41 +	PSW-F15				5	10
	Channel 41 -					18	11
	Channel 41gnd					13 (A4)	4 (A4)
	Channel 42 +	PSW-H15				6	19
	Channel 42 -					19	29
	Channel 42gnd					13 (A4)	4 (A4)
	Channel 43 +	PSW-J15				20	41
	Channel 43 -					7	30
	Channel 43gnd					13 (A4)	4 (A4)
	Channel 44 +	PSW-G15				21	53
	Channel 44 -					8	52
	Channel 44gnd					13 (A4)	4 (A4)
C8-12ax-L	Channel 45 +	PSW-H16				22	9
	Channel 45 -					9	17
	Channel 45gnd					13 (A4)	4 (A4)
	Channel 46 +	PSW-DK2				23	18
	Channel 46 -					10	28
	Channel 46gnd					13 (A4)	4 (A4)
	Channel 47 +	PSW-F16				24	16
	Channel 47 -					11	27
	Channel 47gnd					13 (A4)	4 (A4)
	Channel 48 +	PSW-E15				25	40
	Channel 48 -					12	39
	Channel 48gnd					13 (A4)	4 (A4)
	Harness Overshield		EMC Backshell	EMC Backshell	EMC Backshell	EMC Backshell	

FPU Faraday Shield Link Pins												
1	2	3	5	6	7	8	14	15	24	25	35	82
93	94	104	105	114	115	121	122	123	124	125	126	127

4.4.9 C9 CVV9 to HSJFP Type1

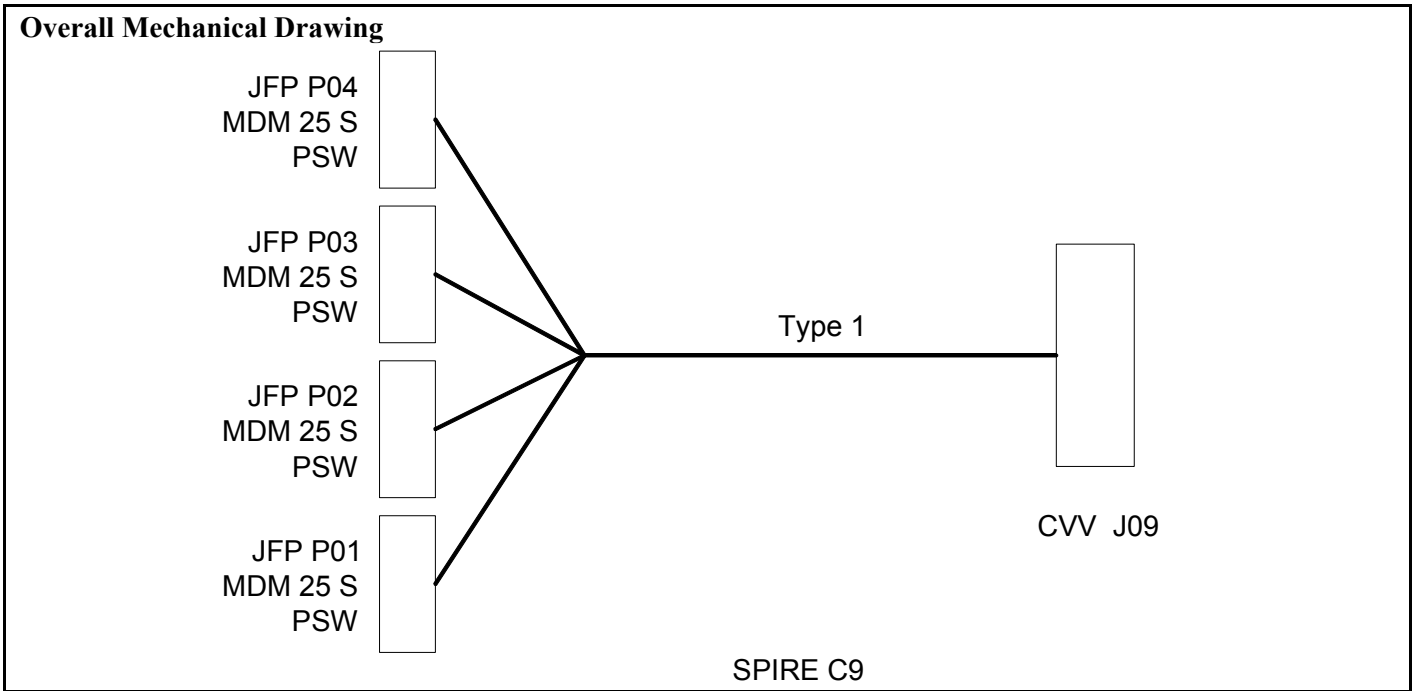

Connector/Backshell Details

MDM25S+Glenair507-T-139-M-37 to	JFPJ1	PSW Signals
MDM25S+Glenair507-T-139-M-37 to	JFPJ2	PSW Signals
MDM25S+Glenair507-T-139-M-37 to	JFPJ3	PSW Signals
MDM25S+Glenair507-T-139-M-37 to	JFPJ4	PSW Signals

Harness Layup

As C4.

Contact Details

As C4.

Table 4.4-9 - SIH-CS-09 Listing

	Name	Pixel	JFP P01	JFP P02	JFP P03	JFP P04	128Way #9
C9-12ax-A	Channel 1 +	PSW-R1	1				26
	Channel 1 -		14				37
	Channel 1gnd		13 (A1)				36 (A1)
	Channel 2 +	PSW-D16	2				38
	Channel 2 -		15				49
	Channel 2gnd		13 (A1)				36 (A1)
	Channel 3 +	PSW-T1	3				48
	Channel 3 -		16				60
	Channel 3gnd		13 (A1)				36 (A1)
	Channel 4 +	PSW-B16	4				59
	Channel 4 -		17				71
	Channel 4gnd		13 (A1)				36 (A1)
C9-12ax-B	Channel 5 +	PSW-C15	5				50
	Channel 5 -		18				61



SPIRE HARNESS DEFINITION DOCUMENT

Doc: SPIRE-RAL-PRJ-000608
Issue: 1.2
Date: 17/02/05
Page 158 of 245

	Name	Pixel	JFP P01	JFP P02	JFP P03	JFP P04	128Way #9
	Channel 5gnd		13 (A1)				36 (A1)
	Channel 6 +	PSW-A15	6				62
	Channel 6 -		19				51
	Channel 6gnd		13 (A1)				36 (A1)
	Channel 7 +	PSW-D15	20				63
	Channel 7 -		7				75
	Channel 7gnd		13 (A1)				36 (A1)
	Channel 8 +	PSW-B15	21				74
	Channel 8 -		8				73
Channel 8gnd	13 (A1)					36 (A1)	
C9-12ax-C	Channel 9 +	PSW-C14	22				83
	Channel 9 -		9			72	
	Channel 9gnd		13 (A1)				36 (A1)
	Channel 10 +	PSW-D14	23				95
	Channel 10 -		10			84	
	Channel 10gnd		13 (A1)				36 (A1)
	Channel 11 +	PSW-A14	24				96
	Channel 11 -		11			85	
	Channel 11gnd		13 (A1)				36 (A1)
	Channel 12 +	PSW-A13	25				106
	Channel 12 -		12			107	
	Channel 12gnd		13 (A1)				36 (A1)
C9-12ax-D	Channel 13 +	PSW-B14		1			86
	Channel 13 -			14		87	
	Channel 13gnd			13 (A2)		128 (A2)	
	Channel 14 +	PSW-C13		2			97
	Channel 14 -			15		98	
	Channel 14gnd			13 (A2)		128 (A2)	
	Channel 15 +	PSW-B13		3			108
	Channel 15 -			16		109	
	Channel 15gnd			13 (A2)		128 (A2)	
	Channel 16 +	PSW-D13		4			116
	Channel 16 -			17		117	
	Channel 16gnd			13 (A2)		128 (A2)	
C9-12ax-E	Channel 17 +	PSW-A12		5			55
	Channel 17 -			18		66	
	Channel 17gnd			13 (A2)		128 (A2)	
	Channel 18 +	PSW-C12		6			67
	Channel 18 -			19		78	
	Channel 18gnd			13 (A2)		128 (A2)	
	Channel 19 +	PSW-D12		20			76
	Channel 19 -			7		77	
	Channel 19gnd			13 (A2)		128 (A2)	
	Channel 20 +	PSW-B12		21			88
	Channel 20 -			8		89	
	Channel 20gnd			13 (A2)		128 (A2)	
C9-12ax-F	Channel 21 +	PSW-E11		22			99
	Channel 21 -			9		100	
	Channel 21gnd			13 (A2)		128 (A2)	
	Channel 22 +	PSW-A11		23			110
	Channel 22 -			10		111	
	Channel 22gnd			13 (A2)		128 (A2)	
	Channel 23 +	PSW-C11		24			118
	Channel 23 -			11		119	
	Channel 23gnd			13 (A2)		128 (A2)	
	Channel 24 +	PSW-B11		25			112
	Channel 24 -			12		120	
	Channel 24gnd			13 (A2)		128 (A2)	
C9-12ax-G	Channel 25 +	PSW-E1			1		90
	Channel 25 -				14		79
	Channel 25gnd				13 (A3)		47 (A3)
	Channel 26 +	PSW-F1			2		102
	Channel 26 -				15		101
	Channel 26gnd				13 (A3)		47 (A3)
	Channel 27 +	PSW-T2			3		92
	Channel 27 -				16		91
	Channel 27gnd				13 (A3)		47 (A3)
	Channel 28 +	PSW-H1			4		103
	Channel 28 -				17		113
	Channel 28gnd				13 (A3)		47 (A3)



SPIRE HARNESS DEFINITION DOCUMENT

Doc: SPIRE-RAL-PRJ-000608
Issue: 1.2
Date: 17/02/05
Page 159 of 245

	Name	Pixel	JFP P01	JFP P02	JFP P03	JFP P04	128Way #9
C9-12ax-H	Channel 29 +	PSW-G1			5		58
	Channel 29 -				18		46
	Channel 29gnd				13 (A3)		47 (A3)
	Channel 30 +	PSW-J1			6		68
	Channel 30 -				19		57
	Channel 30gnd				13 (A3)		47 (A3)
	Channel 31 +	PSW-H2			20		69
	Channel 31 -				7		80
	Channel 31gnd				13 (A3)		47 (A3)
	Channel 32 +	PSW-F2			21		70
Channel 32 -				8		81	
Channel 32gnd				13 (A3)		47 (A3)	
C9-12ax-I	Channel 33 +	PSW-J2			22		23
	Channel 33 -				9		34
	Channel 33gnd				13 (A3)		47 (A3)
	Channel 34 +	PSW-G2			23		33
	Channel 34 -				10		45
	Channel 34gnd				13 (A3)		47 (A3)
	Channel 35 +	PSW-H3			24		44
	Channel 35 -				11		56
	Channel 35gnd				13 (A3)		47 (A3)
	Channel 36 +	PSW-J3			25		22
Channel 36 -				12		32	
Channel 36gnd				13 (A3)		47 (A3)	
C9-12ax-J	Channel 37 +	PSW-E2				1	13
	Channel 37 -					14	12
	Channel 37gnd					13 (A4)	4 (A4)
	Channel 38 +	PSW-F3				2	21
	Channel 38 -					15	20
	Channel 38gnd					13 (A4)	4 (A4)
	Channel 39 +	PSW-G3				3	31
	Channel 39 -					16	43
	Channel 39gnd					13 (A4)	4 (A4)
	Channel 40 +	PSW-H4				4	42
Channel 40 -					17	54	
Channel 40gnd					13 (A4)	4 (A4)	
C9-12ax-K	Channel 41 +	PSW-J4				5	10
	Channel 41 -					18	11
	Channel 41gnd					13 (A4)	4 (A4)
	Channel 42 +	PSW-E3				6	19
	Channel 42 -					19	29
	Channel 42gnd					13 (A4)	4 (A4)
	Channel 43 +	PSW-F4				20	41
	Channel 43 -					7	30
	Channel 43gnd					13 (A4)	4 (A4)
	Channel 44 +	PSW-G4				21	53
Channel 44 -					8	52	
Channel 44gnd					13 (A4)	4 (A4)	
C9-12ax-L	Channel 45 +	PSW-H5				22	9
	Channel 45 -					9	17
	Channel 45gnd					13 (A4)	4 (A4)
	Channel 46 +	PSW-E4				23	18
	Channel 46 -					10	28
	Channel 46gnd					13 (A4)	4 (A4)
	Channel 47 +	PSW-J5				24	16
	Channel 47 -					11	27
	Channel 47gnd					13 (A4)	4 (A4)
	Channel 48 +	PSW-F5				25	40
Channel 48 -					12	39	
Channel 48gnd					13 (A4)	4 (A4)	
	Harness Overshield		EMC Backshell	EMC Backshell	EMC Backshell	EMC Backshell	

FPU Faraday Shield Link Pins												
1	2	3	5	6	7	8	14	15	24	25	35	82
93	94	104	105	114	115	121	122	123	124	125	126	127



SPIRE HARNESS DEFINITION DOCUMENT

Doc: SPIRE-RAL-PRJ-000608
 Issue: 1.2
 Date: 17/02/05
 Page 160 of 245

4.4.10 C10 CVV10 to HSFPU AUX-P

Overall Mechanical Drawing

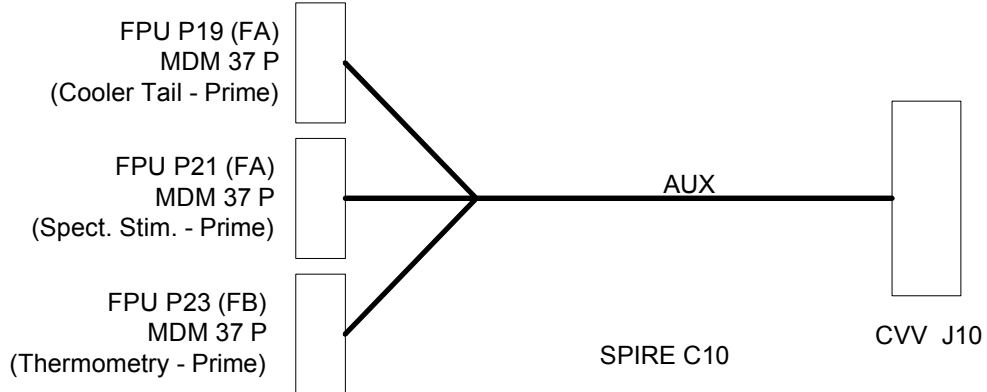

Connector/Backshell Details

Prime side harness

MDM37P + Glenair 507-T-139-M-37	to	FPUJ19	FA - Cooler (P)
MDM37P + Glenair 507-T-139-M-37	to	FPUJ21	FA - Spect. Stim. (P)
MDM37P + Glenair 507-T-139-M-37	to	FPUJ23	FB - Therm. (P)

Harness Layup

Cooler Tail (FPU P19)

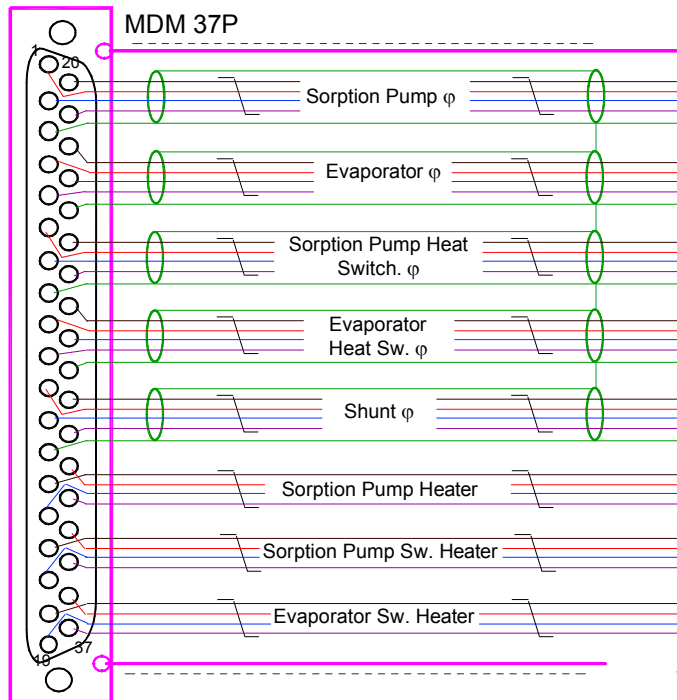

Sorption Cooler (FPU P19/P20)

- 5 Insulated STQs
- 3 Insulated TQs
- See Section 4.4 for details regarding the implementation of the shields.
- The dotted lines indicate insulation jacket covering the overshield. Only required at clamp points but could cover entire length of harness.
- Harness connector is a **Plug**. Drawing indicates pin allocation as seen from the rear, non-engaging face of the connector.

32 pins +
 5 signal shield+
 1 harness shield
 at 128 way



SPIRE HARNESS DEFINITION DOCUMENT

Doc: SPIRE-RAL-PRJ-000608
 Issue: 1.2
 Date: 17/02/05
 Page 161 of 245

Spect. Stimulus Tail FPU P21/P22

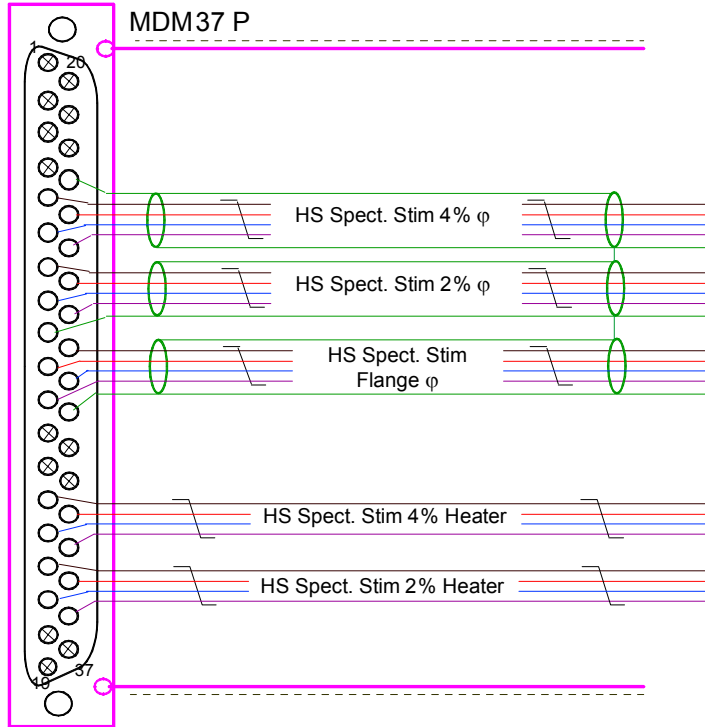

Spectrometer Stimulus Tails (FPU P21/P22)

- 3 Insulated STQs
- 2 Insulated TQs
- See Section 4.4 for details regarding the implementation of the shields.
- The dotted lines indicate insulation jacket covering the overshield. Only required at clamp points but could cover entire length of harness.
- Harness connector is a **Plug**. Drawing indicates pin allocation as seen from the rear, non-engaging face of the connector.

20 pins +
 3 signal shield +
 harness shield
 at 128 way

HSFPU Thermometry Tail (P23/P24)

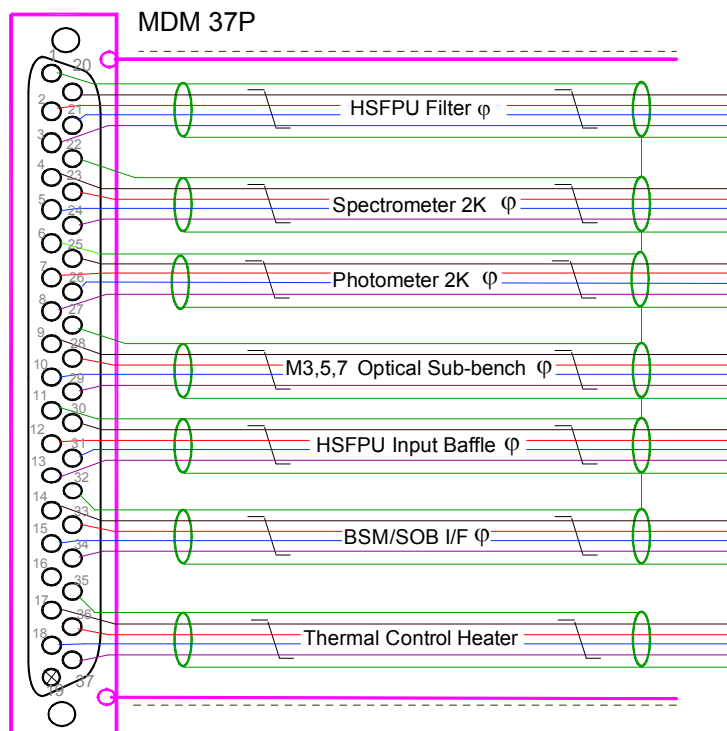

Thermometry Tails (FPU P23/P24)

- 7 Insulated STQs
- See Section 4.4 for details regarding the implementation of the shields.
- The dotted lines indicate insulation jacket covering the overshield. Only required at clamp points but could cover entire length of harness.
- Harness connector is a **Plug**. Drawing indicates pin allocation as seen from the rear, non-engaging face of the connector.

28 pins +
 7 signal grounds +
 harness screen
 at 128way



SPIRE HARNESS DEFINITION DOCUMENT

Doc: SPIRE-RAL-PRJ-000608

Issue: 1.2

Date: 17/02/05

Page 162 of 245

CVV C10 128-Way Pin Allocations (View of wiring side of connector)

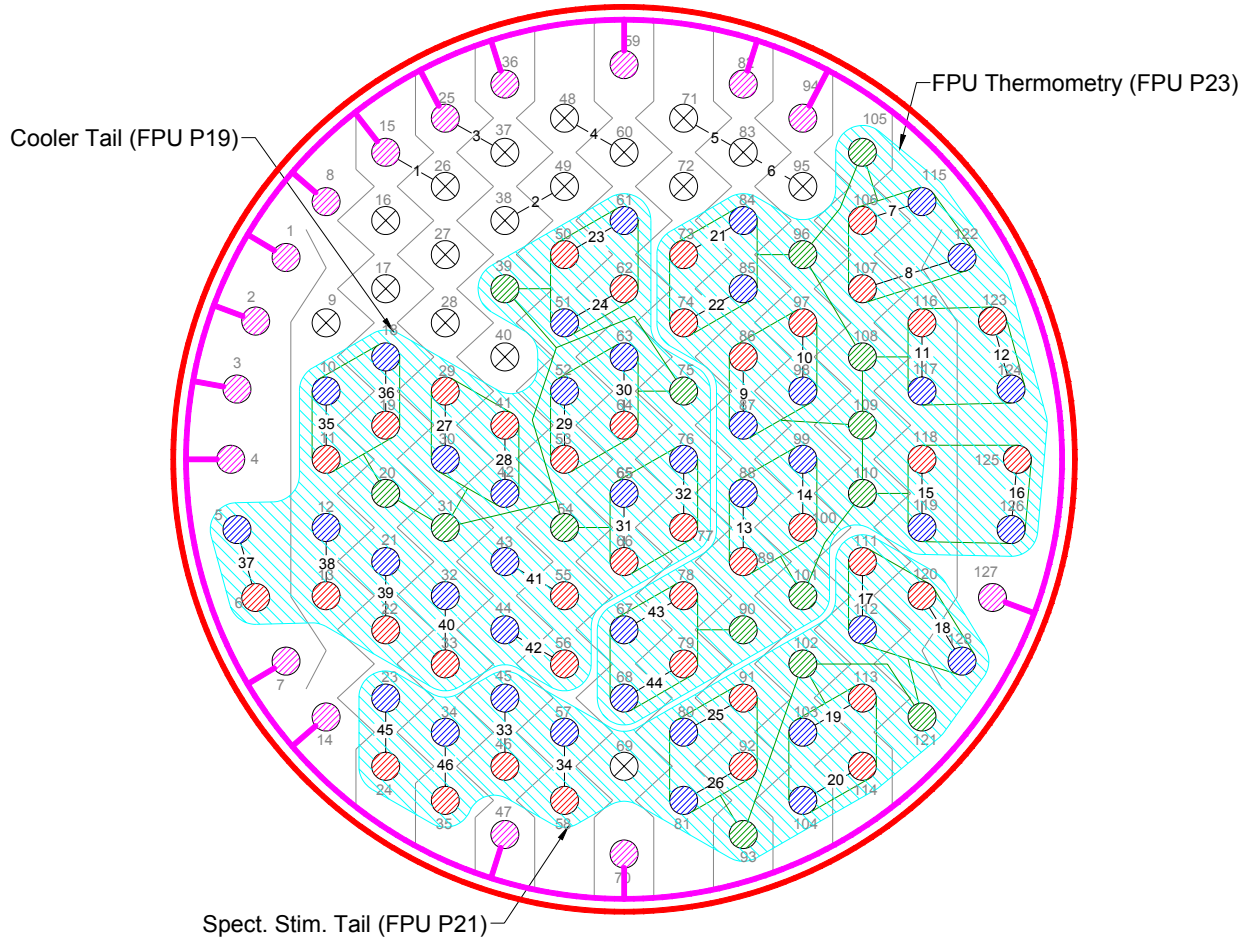

- Signal Supply Pin**
- Signal Return Pin**
- Signal Ground Pin**
- FPU Faraday Shield Link Pin**
- No Connection**
- Harness Tails**
- Connector Chassis (isolated from FPU Faraday Shield)**
- FPU Faraday Shield (i.e. Harness overshield - isolated from S/C structure)**
- Ground Plane Interconnection**



SPIRE HARNESS DEFINITION DOCUMENT

Doc: SPIRE-RAL-PRJ-000608

Issue: 1.2

Date: 17/02/05

Page 163 of 245

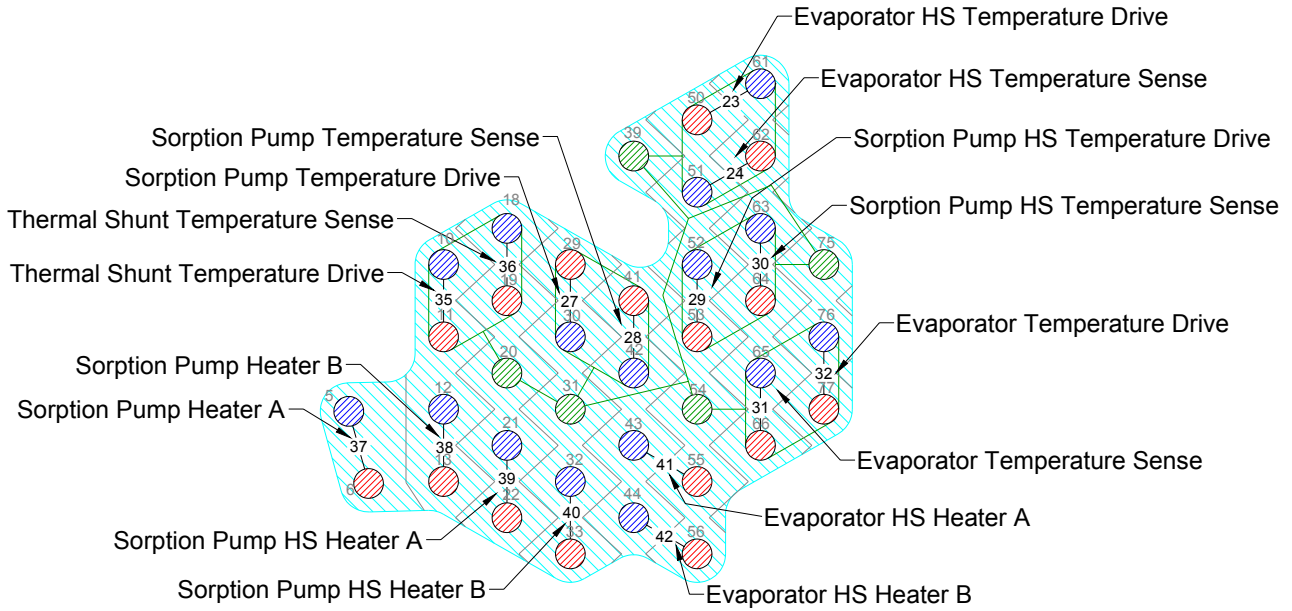

Cooler Tail (FPU P19)



SPIRE HARNESS DEFINITION DOCUMENT

Doc: SPIRE-RAL-PRJ-000608
 Issue: 1.2
 Date: 17/02/05
 Page 164 of 245

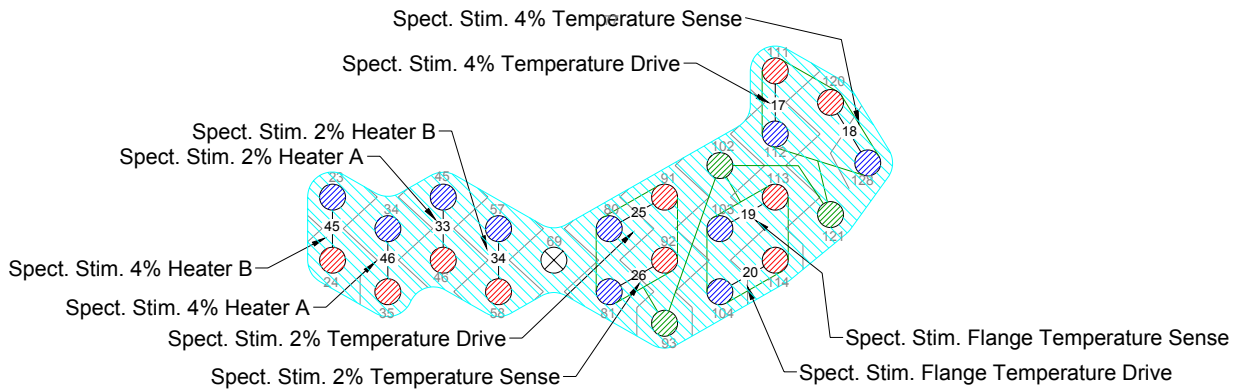

Spectrometer Stimulus Tail (FPU P21)

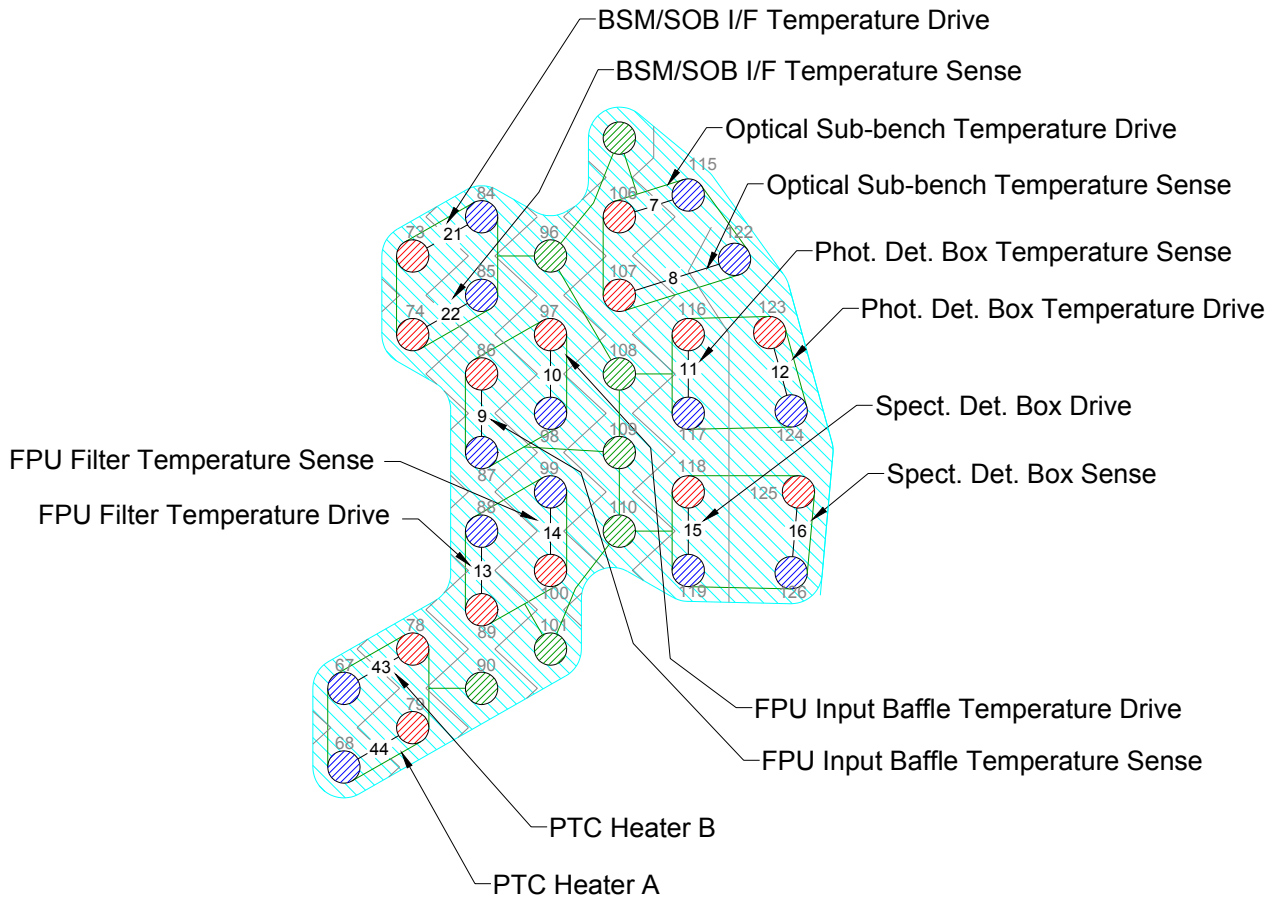

FPU Thermometry (FPU P23)

Table 4.4-10 - SIH-CS-10 Cooler Tail (FPU P19) Listing

Function	37way P19	Max. current	Wire lay-up	Max Ohms	128Way #10
Sorption Pump temperature I+	20	1 μ A	Insulated screened twisted quad	1000	29
Sorption Pump temperature V+	1	N/A		1000	41
Sorption Pump temperature V-	2	N/A		1000	42
Sorption Pump temperature I-	21	1 μ A		1000	30
Sorption Pump temperature shld	3	N/A		N/A	31
Evaporator temperature I+	22	250 nA	Insulated screened twisted quad	1000	77
Evaporator temperature V+	4	N/A		1000	66
Evaporator temperature V-	5	N/A		1000	65
Evaporator temperature I-	23	250 nA		1000	76
Evaporator temperature shld	24	N/A		N/A	54
Sorption Pump Heat Switch temperature I+	25	1 μ A	Insulated screened twisted quad	1000	53
Sorption Pump Heat Switch temperature V+	6	N/A		1000	64
Sorption Pump Heat Switch temperature V-	7	N/A		1000	63
Sorption Pump Heat Switch temperature I-	26	1 μ A		1000	52
Sorption Pump Heat Switch temperature shld	8	N/A		N/A	75
Evaporator Heat Switch temperature I+	27	1 μ A	Insulated screened twisted quad	1000	50
Evaporator Heat Switch temperature V+	9	N/A		1000	62
Evaporator Heat Switch temperature V-	10	N/A		1000	51
Evaporator Heat Switch temperature I-	28	1 μ A		1000	61
Evaporator Heat Switch temperature shld	29	N/A		N/A	39
Thermal Shunt temperature I+ A	30	1 μ A	Insulated screened twisted quad	1000	11
Thermal Shunt temperature V+ B	11	N/A		1000	19
Thermal Shunt temperature V- A	12	N/A		1000	18
Thermal Shunt temperature I- B	31	1 μ A		1000	10
Thermal Shunt temperature shld	13	N/A		N/A	20
Sorption Pump Heater I+ A	14	25 mA	twisted quad	10	6
Sorption Pump Heater I+ B	32	25 mA		10	13
Sorption Pump Heater I- A	15	25 mA		10	5
Sorption Pump Heater I- B	33	25 mA		10	12
Sorption Pump Heat Switch Heater I+ A	16	1.5 mA	twisted quad	50	22
Sorption Pump Heat Switch Heater I+ B	34	1.5 mA		50	33
Sorption Pump Heat Switch Heater I- A	17	1.5 mA		50	21
Sorption Pump Heat Switch Heater I- B	35	1.5 mA		50	32
Evaporator Heat Switch Heater I+ A	18	1.5 mA	twisted quad	50	55
Evaporator Heat Switch Heater I+ B	36	1.5 mA		50	56
Evaporator Heat Switch Heater I- A	19	1.5 mA		50	43
Evaporator Heat Switch Heater I- B	37	1.5 mA		50	44

32 wires and 5 temperature sensor signal shield

Table 4.4-11 - SIH-CS-10 Spectrometer Stimulus Tail (FPU P21) Listing

Function	37way P21	Max. current	Wire lay-up	Max Ohms	128Way #10
HS Spect. 4% temperature I+	5	1 μ A	Insulated screened twisted quad	1000	111
HS Spect. 4% temperature V+	6	N/A		1000	120
HS Spect. 4% temperature V-	24	N/A		1000	128
HS Spect. 4% temperature I-	25	1 μ A		1000	112
HS Spect. 4% temperature shld	23	N/A		N/A	121
HS Spect. 2% temperature I+	7	1 μ A	Insulated screened twisted quad	1000	91
HS Spect. 2% temperature V+	8	N/A		1000	92
HS Spect. 2% temperature V-	26	N/A		1000	81
HS Spect. 2% temperature I-	27	1 μ A		1000	80
HS Spect. 2% temperature shld	9	N/A		N/A	93
HS Spect. Stim Flange temperature I+	10	1 μ A	Insulated screened twisted quad	1000	114
HS Spect. Stim Flange temperature V+	11	N/A		1000	113
HS Spect. Stim Flange temperature V-	28	N/A		1000	103
HS Spect. Stim Flange temperature I-	29	1 μ A		1000	104
HS Spect. Stim Flange temperature shld	30	N/A		N/A	102
HS Spect. 4% Heater I+ A	14	9 mA	Twisted quad	30	35
HS Spect. 4% Heater V+ B	15	9 mA		30	24
HS Spect. 4% Heater I- A	33	9 mA		30	34
HS Spect. 4% Heater V- B	34	9 mA		30	23
HS Spect. 2% Heater I+ A	16	7 mA	Twisted quad	30	46
HS Spect. 2% Heater V+ B	17	7 mA		30	58
HS Spect. 2% Heater I- A	35	7 mA		30	45
HS Spect. 2% Heater V- B	36	7 mA		30	57

20 wires + 1 temperature sensor signal shield

Table 4.4-12 - SIH-CS-10 FPU Thermometry Tail (P23) Listing

Function	37way P23	Max. current	Wire lay-up	Max Ohms	128Way #10
FPU Filter temperature I+	20	1 μ A	Insulated screened twisted quad	1000	89
FPU Filter temperature V+	2	N/A		1000	100
FPU Filter temperature V-	3	N/A		1000	99
FPU Filter temperature I-	21	1 μ A		1000	88
FPU Filter temperature shld	1	N/A		N/A	101
Spectrometer Det. Box temperature I+	4	1 μ A	Insulated screened twisted quad	1000	118
Spectrometer Det. Box temperature V+	23	N/A		1000	125
Spectrometer Det. Box temperature V-	24	N/A		1000	126
Spectrometer Det. Box temperature I-	5	1 μ A		1000	119
Spectrometer Det. Box temperature shld	22	N/A		N/A	110
Photometer Det. Box temperature I+	25	1 μ A	Insulated screened twisted quad	1000	123
Photometer Det. Box temperature V+	7	N/A		1000	116
Photometer Det. Box temperature V-	8	N/A		1000	117
Photometer Det. Box temperature I-	26	1 μ A		1000	124
Photometer Det. Box temperature shld	6	N/A		N/A	108
Optical Subench temperature I+	9	1 μ A	Insulated	1000	106
Optical Subench temperature V+	28	N/A		1000	107

Optical Subench temperature V-	29	N/A	screened twisted quad	1000	122
Optical Subench temperature I-	10	1 μ A		1000	115
Optical Subench temperature shld	27	N/A		N/A	105
HSFPU Input Baffle temperature I+	30	1 μ A	Insulated screened twisted quad	1000	97
HSFPU Input Baffle temperature V+	12	N/A		1000	86
HSFPU Input Baffle temperature V-	13	N/A		1000	87
HSFPU Input Baffle temperature I-	31	1 μ A		1000	98
HSFPU Input Baffle temperature shld	11	N/A		N/A	109
BSM/SOB I/F temperature I+	14	1 μ A	Insulated screened twisted quad	1000	73
BSM/SOB I/F temperature V+	33	N/A		1000	74
BSM/SOB I/F temperature V-	34	N/A		1000	85
BSM/SOB I/F temperature I-	15	1 μ A		1000	84
BSM/SOB I/F temperature shld	32	N/A		N/A	96
PTC Heater I+ A	17	2mA	Insulated screened twisted quad	100	79
PTC Heater I+ B	18	2 mA		100	78
PTC Heater I- A	36	2 mA		100	68
PTC Heater I- B	37	2 mA		100	67
PTC Heater shld.	35	N/A		N/A	90

Total contacts 28 wires and 7 shields

FPU Faraday Shield Link Pins							
1	2	3	4	7	8	14	15
25	36	47	59	70	82	94	127



SPIRE HARNESS DEFINITION DOCUMENT

Doc: SPIRE-RAL-PRJ-000608
 Issue: 1.2
 Date: 17/02/05
 Page 168 of 245

4.4.11 C11 CVV11 to HSFPU DRV-P

Overall Mechanical Drawing

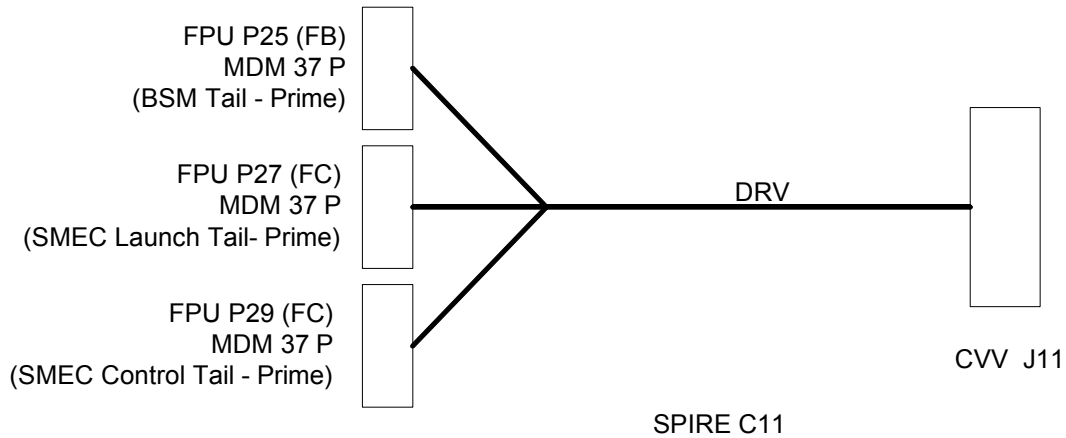

Connector/Backshell Details

MDM37P + Glenair 507 - T - 196 - M - 37 to	FPUJ25	FB - BSM (P)
MDM37P + Glenair 507 - T - 186 - M - 37 to	FPUJ27	FC - SMEC Launch (P)
MDM37P + Glenair 507 - T - 196 - M - 37 to	FPUJ29	FC - SMEC Control (P)

Harness Layup

BSM Tail

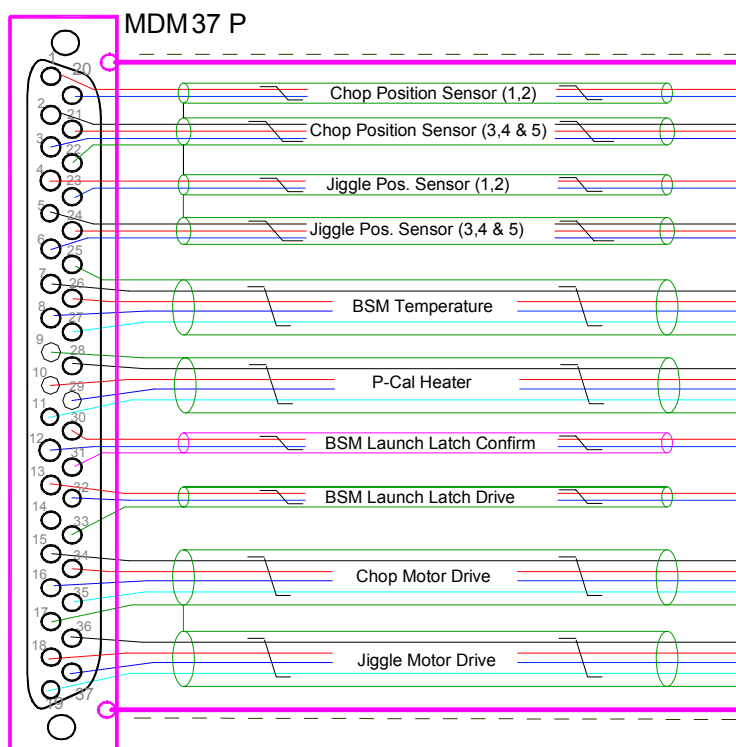

BSM Tails (FPU P25/P26)

- 4 Insulated STQs
- 4 Insulated STPs
- 2 Insulated STTs
- See Section 4.4 for details regarding the implementation of the shields.
- The dotted lines indicate insulation jacket covering the overshield. Only required at clamp points but could cover entire length of harness.
- Harness connector is a **Plug**. Drawing indicates pin allocation as seen from the rear, non-engaging face of the connector.



SPIRE HARNESS DEFINITION DOCUMENT

Doc: SPIRE-RAL-PRJ-000608

Issue: 1.2

Date: 17/02/05

Page 169 of 245

SMEC Launch/Thermal Tail

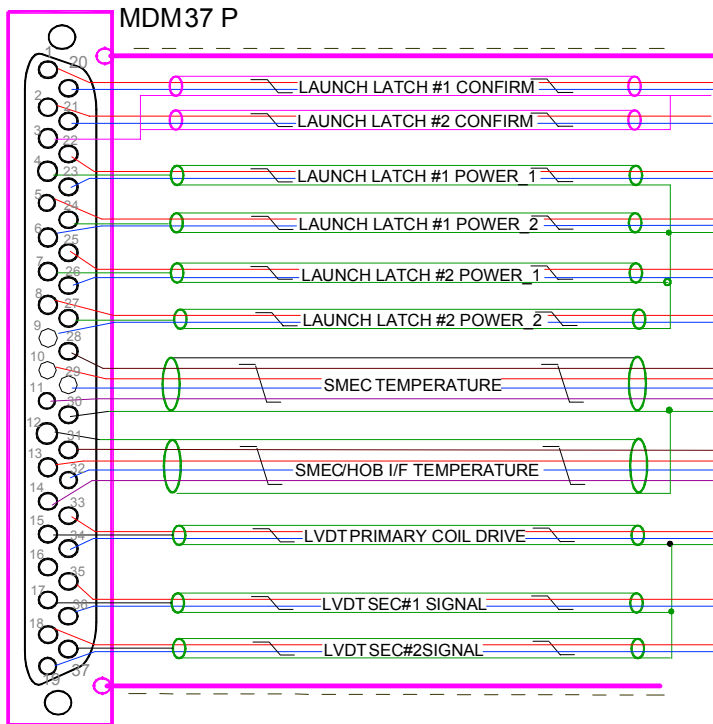

SMEC Launch / Thermal Tail (FPU P27/P28)

- 2 Insulated STQs
- 9 Insulated STPs
- See Section 4.4 for details regarding the implementation of the shields.
- The dotted lines indicate insulation jacket covering the overshield. Only required at clamp points but could cover entire length of harness.
- Harness connector is a **Plug**. Drawing indicates pin allocation as seen from the rear, non-engaging face of the connector.

26 (20) signal pins +
4 signal grounds+
harness screen
at 128 way

SMEC Control Tail

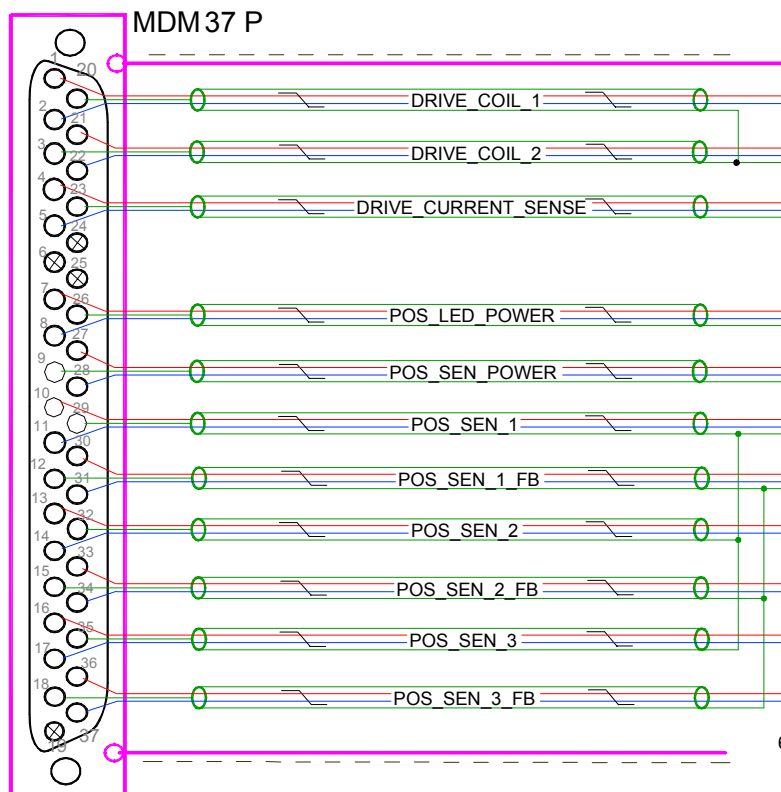

SMEC Control Tail (FPU P29/P30)

- 11 Insulated STPs
- See Section 4.4 for details regarding the implementation of the shields.
- The dotted lines indicate insulation jacket covering the overshield. Only required at clamp points but could cover entire length of harness.
- Harness connector is a **Plug**. Drawing indicates pin allocation as seen from the rear, non-engaging face of the connector.

22 signal pins +
6 signal grounds+
harness screen
at 128way



SPIRE HARNESS DEFINITION DOCUMENT

Doc: SPIRE-RAL-PRJ-000608







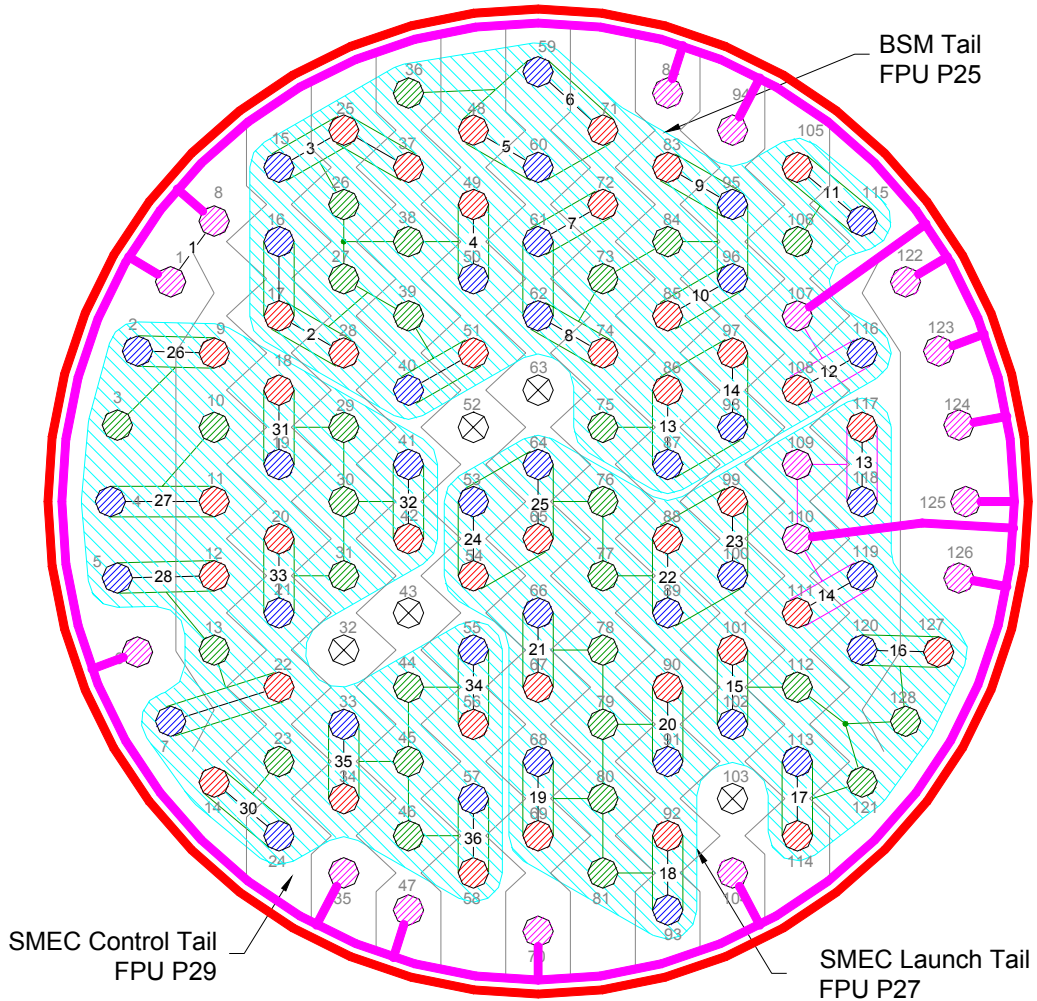

Issue: 1.2

Date: 17/02/05

Page 170 of 245

CVV C11 128-Way Pin Allocations (View of wiring side of connector)



-  **Signal Supply Pin**
-  **Signal Return Pin**
-  **Signal Ground Pin**
-  **FPU Faraday Shield Link Pin**
-  **No Connection**
-  **Harness Tails**
-  **Connector Chassis (isolated from FPU Faraday Shield)**
-  **FPU Faraday Shield (i.e. Harness overshield - isolated from S/C structure)**
-  **Ground Plane Interconnection**



SPIRE HARNESS DEFINITION DOCUMENT

Doc: SPIRE-RAL-PRJ-000608

Issue: 1.2

Date: 17/02/05

Page 171 of 245

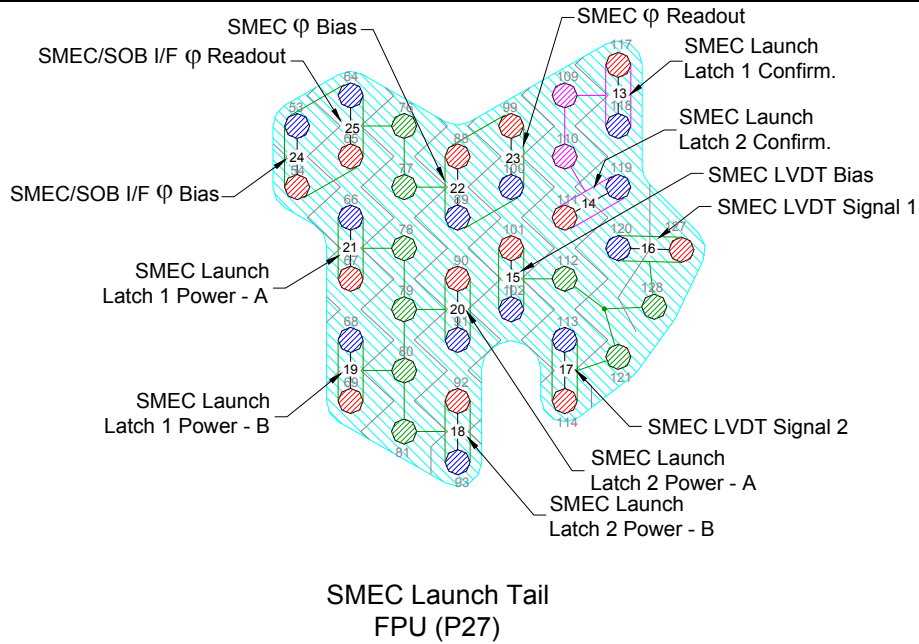
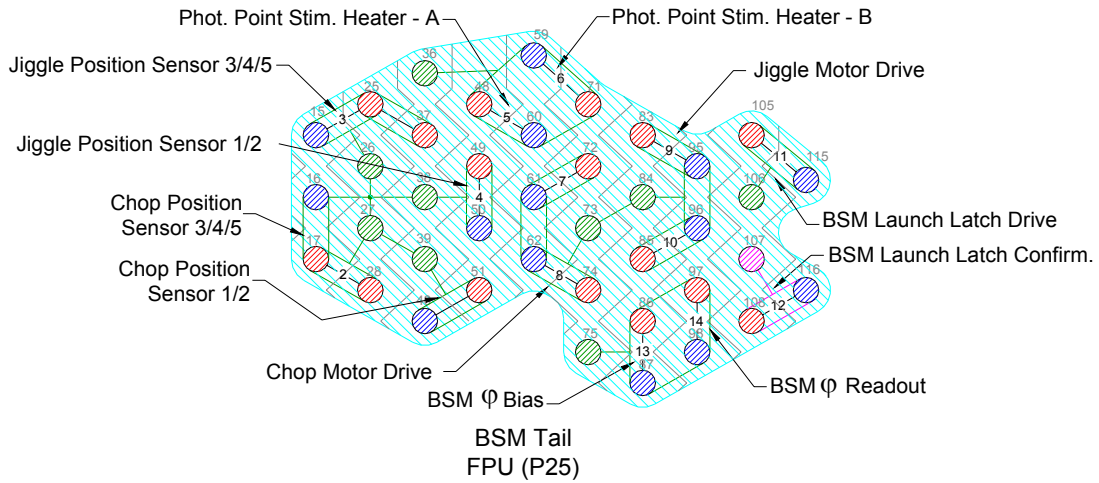



SPIRE HARNESS DEFINITION DOCUMENT

Doc: SPIRE-RAL-PRJ-000608

Issue: 1.2

Date: 17/02/05

Page 172 of 245

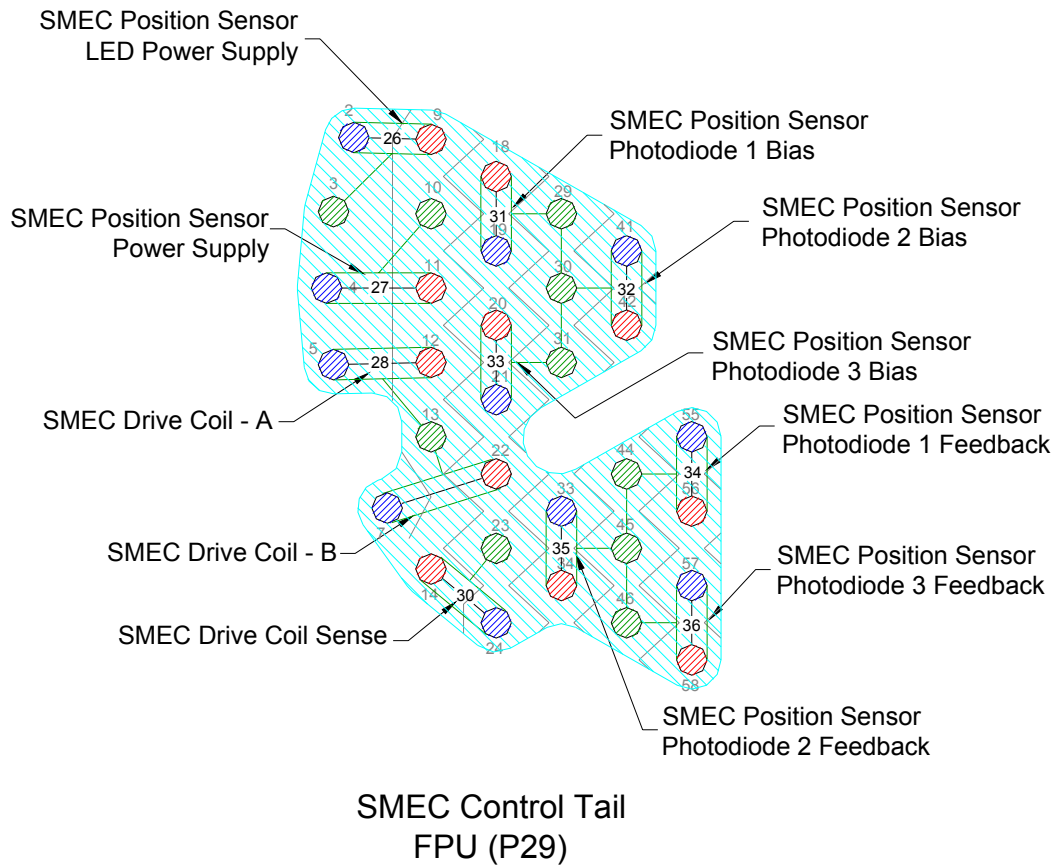

Table 4.4-13 - SIH-CS-11 BSM Tail (FPU P25) Listing

Function	37way P25	Max. current	Wire lay-up	Max Ohms	128Way #11
Chop Position Sensor 1	1	1 μ A	Insulated screened twisted pair	1000	51
Chop Position Sensor 2	20	N/A		1000	40
Chop Position Sensor shld1	to A	N/A		N/A	39 & Linked to 26, 27 & 38
Chop Position Sensor 3	2	250 nA	Insulated screened twisted triple	1000	28
Chop Position Sensor 4	21	N/A		1000	17
Chop Position Sensor 5	3	N/A		1000	16
Chop Position Sensor shld2=A	22	N/A		N/A	27 & Linked to 39, 26 & 38
Jiggle Position Sensor 1	4	1 μ A		Insulated screened twisted pair	1000
Jiggle Position Sensor 2	23	N/A	1000		50
Jiggle Position Sensor shld1	to B	N/A	N/A		38 & Linked to 26, 27 & 39
Jiggle Position Sensor 3	5	250nA	Insulated screened twisted triple	1000	15
Jiggle Position Sensor 4	24	N/A		1000	25
Jiggle Position Sensor 5	6	N/A		1000	37
Jiggle Position Sensor shld2=B	22	N/A		N/A	26 & Linked to 39, 27 & 38
BSM temperature I+	7	1 μ A		Insulated screened twisted quad	1000
BSM temperature V+	26	N/A	1000		97
BSM temperature V-	8	N/A	1000		98
BSM temperature I-	27	1 μ A	1000		87
BSM temperature shld	25	N/A	N/A		75
Photometer Point Stim. Heater I+ A	28	7mA	Insulated screened twisted quad	10	48
Photometer Point Stim.Heater V+ B	10	7mA		10	71
Photometer Point Stim.Heater I- A	29	7mA		10	60
Photometer Point Stim.Heater V- B	11	7mA		10	59
Photometer Point Stim.Heater shld	9	N/A		N/A	36
BSM Launch latch confirmation 1	30	1mA	Insulated screened twisted pair	1000	108
BSM Launch latch confirmation 2	12	1mA		1000	116
Launch latch conf. shld (connected to BSM Chassis in FPU)	31	N/A		N/A	107
BSM Launch latch drive +	13	35mA	Insulated screened twisted pair	10	105
BSM Launch latch drive -	32	35mA		10	115
BSM Launch latch drive shld	33	N/A		N/A	106
Chop Motor Drive 1	15	40 mA	Insulated screened twisted quad	10	72
Chop Motor Drive 2	34	40 mA		10	61
Chop Motor Drive 3	16	40 mA		10	62
Chop Motor Drive 4	35	40 mA		10	74
Chop Motor Drive shld	17	N/A		N/A	73 and Linked to 84
Jiggle Motor Drive 1	36	40 mA	Insulated screened twisted quad	10	83
Jiggle Motor Drive 2	18	40 mA		10	95
Jiggle Motor Drive 3	37	40 mA		10	96
Jiggle Motor Drive 4	19	40 mA		10	85
Jiggle Motor Drive shld	17	N/A		N/A	84 and Linked to 73

This 37way connector is has 36 ways populated.

Commoning the Launch Latch Drive shield with that of the motor drives and reassigning launch latch drive 3 would give the BSM a slightly messy 2 wire cryoharness "contingency".

The photometer point stimulus Heater shield may be denied a contact on the 128Way depending on demand by the SMEC tails, TBC. In which case, and only this case, it would be grounded in the BSM.

Table 4.4-14 - SIH-CS-11 SMEC Launch/Therm.Tail (FPU P27) Listing

Function	37way P27	Max. current	Wire lay-up	Max Ohms	128Way #11
SMEC launch latch # 1 confirmation +	1	1 mA	Insulated screened twisted pair	5	117
SMEC launch latch # 1 confirmation -	20	1 mA		5	118
SMEC launch latch # 1 confirmation Shield (connected to SMEC Chassis in FPU)	3	N/A		N/A	109 A [noisy SVM]
SMEC launch latch # 2 confirmation +	2	1 mA	Insulated screened twisted pair	5	111
SMEC launch latch # 2 confirmation -	21	1 mA		5	119
SMEC launch latch # 2 confirmation Shld (connected to SMEC Chassis in FPU)	3	N/A		N/A	110 A[noisy SVM]
SMEC launch latch #1 power supply_1	22	400 mA / 50ms	Insulated screened twisted pair	5	67
SMEC launch latch #1 power return_1	23	400 mA / 50ms		5	66
SMEC launch latch #1 power Shield_1	4	N/A		N/A	B (78)
SMEC launch latch #1 power supply_2	5	400 mA / 50ms	Insulated screened twisted pair	5	69
SMEC launch latch #1 power return_2	6	400 mA / 50ms		5	68
SMEC launch latch #1 power Shield_2	24	N/A		N/A	B (80)
SMEC launch latch #2 power supply_1	25	400 mA / 50ms	Insulated screened twisted pair	5	90
SMEC launch latch #2 power return_1	26	400 mA / 50ms		5	91
SMEC launch latch #2 power Shield_1	7	N/A		N/A	B (79)
SMEC launch latch #2 power supply_2	8	400 mA / 50ms	Insulated screened twisted pair	5	92
SMEC launch latch #2 power return_2	9	400 mA / 50ms		5	93
SMEC launch latch #2 power Shield_2	27	N/A		N/A	B (81)
SMEC temperature I+	28	1 μ A	Insulated screened twisted quad	1000	88
SMEC temperature V+	10	N/A		1000	99
SMEC temperature V-	29	N/A		1000	100
SMEC temperature I-	11	1 μ A		1000	89
SMEC temperature shld	30	N/A		N/A	C (77)
SMEC/SOB I/F temperature I+	31	1 μ A	Insulated screened twisted quad	1000	54
SMEC/SOB I/F temperature V+	13	N/A		1000	65
SMEC/SOB I/F temperature V-	32	N/A		1000	64
SMEC/SOB I/F temperature I-	14	1 μ A		1000	53
SMEC/SOB I/F temperature shld	12	N/A		N/A	C (76)
SMEC LVDT primary coil power supply (P)	33	5 mA	Insulated screened twisted pair	5	101
SMEC LVDT primary coil power supply (N)	34	5 mA		5	102
SMEC LVDT primary coil power supply Shld	15	N/A		N/A	D (112)
SMEC LVDT secondary coil # 1 signal (P)	35	50 μ A	Insulated screened twisted pair	5	127
SMEC LVDT secondary coil # 1 signal (N)	36	50 μ A		5	120
SMEC LVDT secondary coil # 1 signal Shield	17	N/A		N/A	D (128)
SMEC LVDT secondary coil # 2 signal (P)	18	50 μ A	Insulated screened twisted pair	5	114
SMEC LVDT secondary coil # 2 signal (N)	19	50 μ A		5	113
SMEC LVDT secondary coil # 2 signal Shield	37	N/A		N/A	D (121)

31 contacts used

Table 4.4-15 - SIH-CS-11 SMEC Control Tail (FPU J29) Listing

Function	37way J29	Max. current	Wire lay-up	Max Ohms	128Way #11
SMEC Drive Coil I+	1	100mA	Insulated screened twisted pair	5	12
SMEC Drive Coil I-	2	100mA		5	5
SMEC Drive Coil shld	20	N/A		N/A	A (13)
SMEC Drive Coil (Rob) I+	21	100mA	Insulated screened twisted pair	5	22
SMEC Drive Coil (Rob) I-	22	100mA		5	7
SMEC Drive Coil (Rob) shld	3	N/A		N/A	A (13)
SMEC Drive Coil Sense+	4	10 μ A	Insulated screened twisted pair	500	14
SMEC Drive Coil Sense-	5	10 μ A		500	24
SMEC Drive Coil shld	23	N/A		N/A	23
SMEC position sensor Led power supply	7	1mA	Insulated screened twisted pair	100	9
SMEC position sensor Led power return	8	1mA		100	2
SMEC position sensor Led power Shield	26	N/A		N/A	3
SMEC position sensor power supply	27	1mA	Insulated screened twisted pair	100	11
SMEC position sensor power return	28	1mA		100	4
SMEC position sensor power Shield	9	N/A		N/A	10
SMEC position sensor photodiode #1 I+	10	20 μ A	Insulated screened twisted pair	1000	18
SMEC position sensor photodiode #1 I-	11	20 μ A		1000	19
SMEC position sensor photodiode Shield	29	N/A		N/A	B (29)
SMEC pos. sensor photodiode #1 feedback +	30	10 μ A	Insulated screened twisted pair	1000	56
SMEC pos. sensor photodiode #1 feedback -	31	10 μ A		1000	55
SMEC pos. sensor photodiode feedback Shld	12	N/A		N/A	C (44)
SMEC position sensor photodiode #2 I+	13	20 μ A	Insulated screened twisted pair	1000	42
SMEC position sensor photodiode #2 I-	14	20 μ A		1000	41
SMEC position sensor photodiode Shield	32	N/A		N/A	B (30)
SMEC pos. sensor photodiode #2 feedback +	33	10 μ A	Insulated screened twisted pair	1000	34
SMEC pos. sensor photodiode #2 feedback -	34	10 μ A		1000	33
SMEC pos. sensor photodiode feedback Shld	15	N/A		N/A	C (45)
SMEC position sensor photodiode #3 I+	16	20 μ A	Insulated screened twisted pair	1000	20
SMEC position sensor photodiode #3 I-	17	20 μ A		1000	21
SMEC position sensor photodiode Shield	35	N/A		N/A	B (31)
SMEC pos. sensor photodiode #3 feedback +	36	10 μ A	Insulated screened twisted pair	1000	58
SMEC pos. sensor photodiode #3 feedback -	37	10 μ A		1000	57
SMEC pos. sensor photodiode feedback Shld	18	N/A		N/A	C (46)

29 contacts used.

SMEC above based on "Cryo_harness_010906.doc".

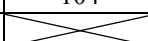
FPU Faraday Shield Link Pins (C11, I11 and S11)								
1	6	8	35	47	70	82	94	104
107	109	110	122	123	124	125	126	

4.4.12 C12 CVV12 to HSFPU AUX-R

Overall Mechanical Drawing

Redundant version of C10, and the same as it

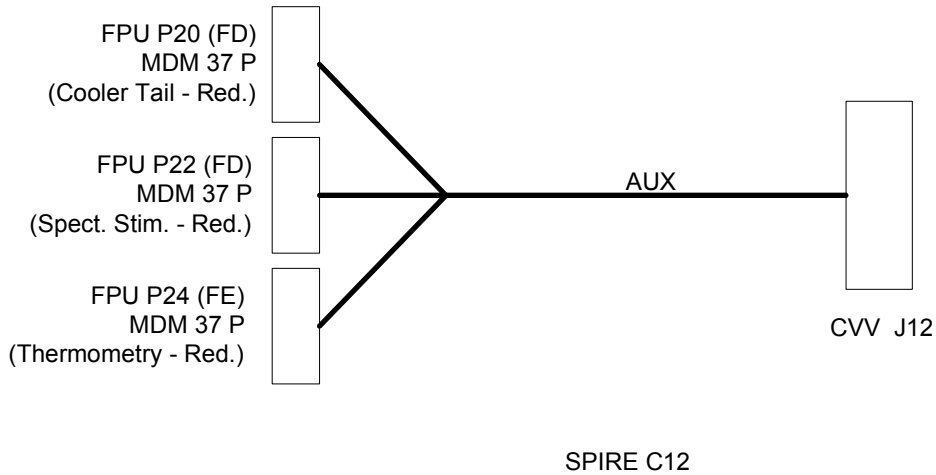

Connector/Backshell Details

Redundant side harness

MDM 37 P +Glenair507-T-139-M-37 to	FPUJ20	FD - Cooler (R)
MDM 37 P +Glenair507-T-139-M-37 to	FPUJ22	FD - Spect. Stim (R)
MDM 37 P +Glenair507-T-139-M-37 to	FPUJ24	FE - Therm. (R)

Harness Layup

Redundant/identical version of C10

Add one to all the connector numbers compared to C10.

4.4.13 C13 CVV13 to HSFPU DRV-R

Overall Mechanical Drawing

Format as C11, maybe differing length.

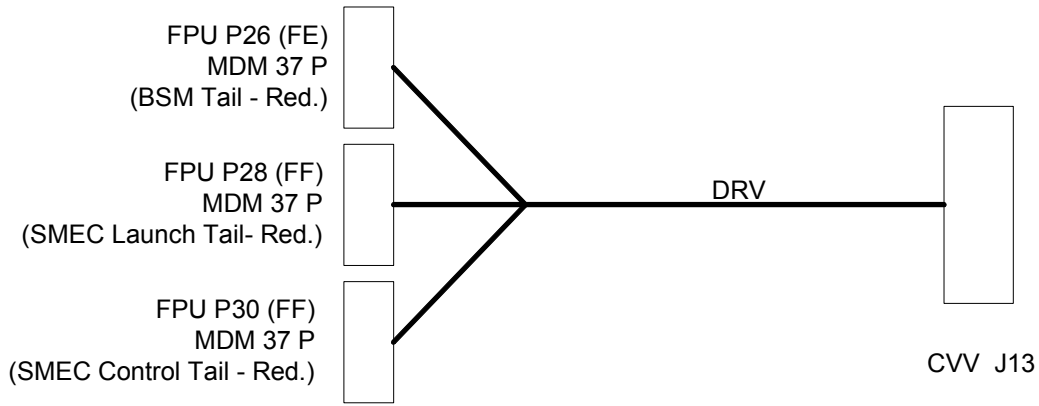

SPIRE C13

Connector/Backshell Details

Redundant side harness

MDM37P + Glenair 507 - T - 139 - M - 37 - F - H to	FPUJ26	FE - BSM (R)
MDM37P + Glenair 507 - T - 139 - M - 37 - F - H to	FPUJ28	FF - SMEC Launch (R)
MDM37P + Glenair 507 - T - 139 - M - 37 - F - H to	FPUJ30	FF - SMEC Control (R)

Harness Layup

As C11.

Contact Details

As C11, but add one to all the connector numbers compared to C11.



SPIRE HARNESS DEFINITION DOCUMENT

Doc: SPIRE-RAL-PRJ-000608

Issue: 1.2

Date: 17/02/05

Page 178 of 245

4.5 FPU Harnesses

4.5.1 F1 PSW BDA J01 to HSJFP J29

Harnesses F1 thru F6 passing from HSJFP to the PSW BDA are potted into a single feedthru mounted on the FPU Photometer Connector Bracket as illustrated below in the mechanical drawing.

Overall Mechanical Drawing

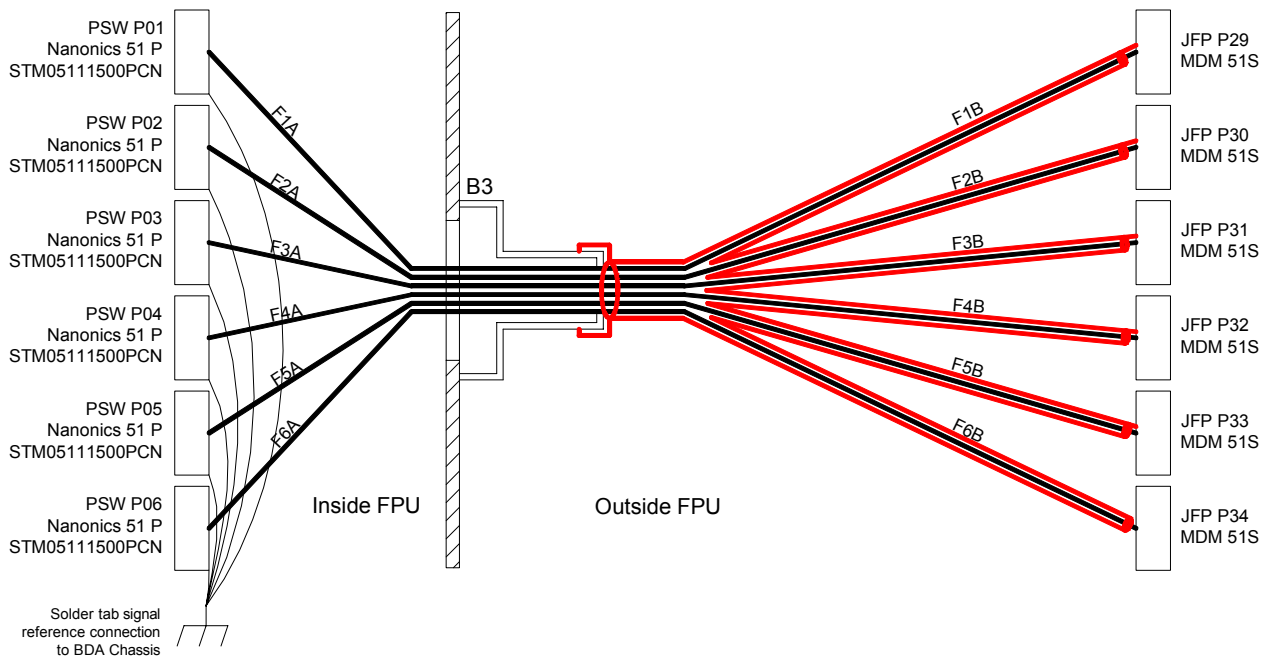

JPL configured Photometer BDA lead, maintaining Faraday cage HSJFP to FPU, and keeping signal ground separate from chassis ground.

Connector/Backshell Details

A section: Nanonics STM05111500PCN with non RF-tight, potted backshell

B section: MDM51S with RF-tight, potted backshell

Harness Layup

B section requires outer RF shield, **A** section does not.

B section may have thermal heatsink attachments, TBD.

Length and tie-downs optimised to minimise capacitance and microphony.

Consists of 6 x 12-ax, each carrying 4 channels, making 24 channels in all plus a screened twisted pair for bias. Careful control of those screens that cannot have their own contact assignment.



SPIRE HARNESS DEFINITION DOCUMENT

Doc: SPIRE-RAL-PRJ-000608
Issue: 1.2
Date: 17/02/05
Page 180 of 245

Contact Details

Function	MDM51 contact	Cable	Nanonics contact
Channel A +	35	12-ax	1
Channel A -	18		26
Channel A gnd	To 12-ax shield one end		To 12-ax shield one end
Channel B +	51		2
Channel B -	17		27
Channel B gnd	To 12-ax shield one end		To 12-ax shield one end
Channel C +	16		3
Channel C -	34		28
Channel C gnd	To 12-ax shield one end		To 12-ax shield one end
Channel D +	33		4
Channel D -	50		29
Channel D gnd	To 12-ax shield one end		To 12-ax shield one end
Channel E +	49	12-ax	5
Channel E -	15		30
Channel E gnd	To 12-ax shield one end		To 12-ax shield one end
Channel F +	14		6
Channel F -	32		31
Channel F gnd	To 12-ax shield one end		To 12-ax shield one end
Channel G +	48		7
Channel G -	31		32
Channel G gnd	To 12-ax shield one end		To 12-ax shield one end
Channel H +	13		8
Channel H-	47		33
Channel H gnd	To 12-ax shield one end		To 12-ax shield one end
Channel I +	30	12-ax	9
Channel I-	12		34
Channel I gnd	To 12-ax shield one end		To 12-ax shield one end
Channel J +	46		10
Channel J-	29		35
Channel J gnd	To 12-ax shield one end		To 12-ax shield one end
Channel K +	11		11
Channel K -	45		36
Channel K gnd	To 12-ax shield one end		To 12-ax shield one end
Channel L +	28		12
Channel L -	10		37
Channel L gnd	To 12-ax shield one end		To 12-ax shield one end
Channel M +	27	12-ax	13
Channel M-	44		38
Channel M gnd	To 12-ax shield one end		To 12-ax shield one end
Channel N +	43		14
Channel N -	9		39
Channel N gnd	To 12-ax shield one end		To 12-ax shield one end
Channel P +	8		15
Channel P -	26		40
Channel P gnd	To 12-ax shield one end		To 12-ax shield one end
Channel R +	25		16
Channel R-	42		41
Channel R gnd	To 12-ax shield one end		To 12-ax shield one end
Channel S+	41	12-ax	17
Channel S -	7		42
Channel S gnd	To 12-ax shield one end		To 12-ax shield one end
Channel T+	6		18
Channel T -	24		43
Channel T gnd	To 12-ax shield one end		To 12-ax shield one end
Channel U +	40		19
Channel U -	23		44
Channel U gnd	To 12-ax shield one end		To 12-ax shield one end
Channel V +	5		20
Channel V-	39		45
Channel V gnd	To 12-ax shield one end		To 12-ax shield one end



SPIRE HARNESS DEFINITION DOCUMENT

Doc: SPIRE-RAL-PRJ-000608
Issue: 1.2
Date: 17/02/05
Page 181 of 245

Function	MDM51 contact	Cable	Nanonics contact
Channel W +	22	12-ax	21
Channel W -	4		46
Channel W gnd	To 12-ax shield one end		To 12-ax shield one end
Channel X +	38		22
Channel X -	21		47
Channel X gnd	To 12-ax shield one end		To 12-ax shield one end
Channel Y +	3		23
Channel Y -	37		48
Channel Y gnd	To 12-ax shield one end		To 12-ax shield one end
Channel Z+	20		24
Channel Z -	36		49
Channel Z gnd	To 12-ax shield one end		To 12-ax shield one end
Bias +	1	STT	25
Bias_	2		50
Bias gnd	19+commoned shlds		51+commoned shlds

N.B. None of the gnds./braids in the above shall be connected to backshell and hence chassis.

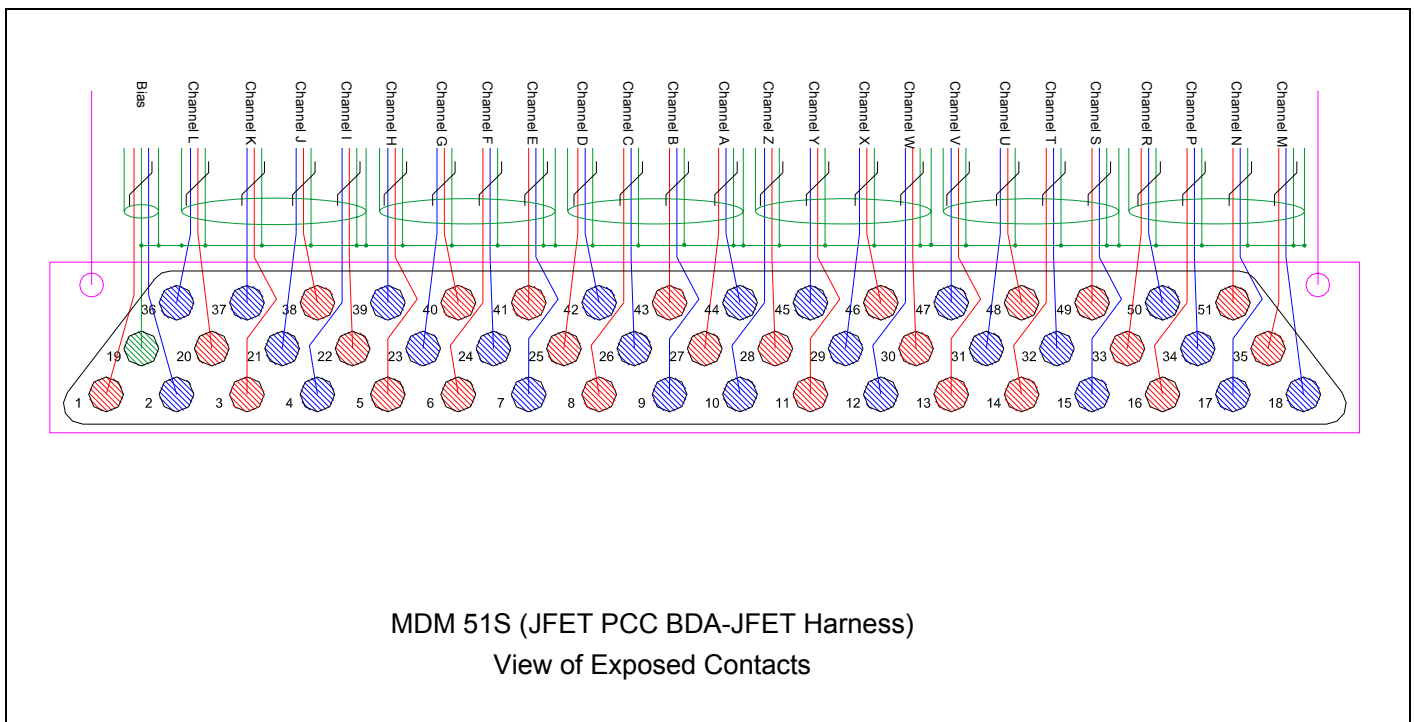
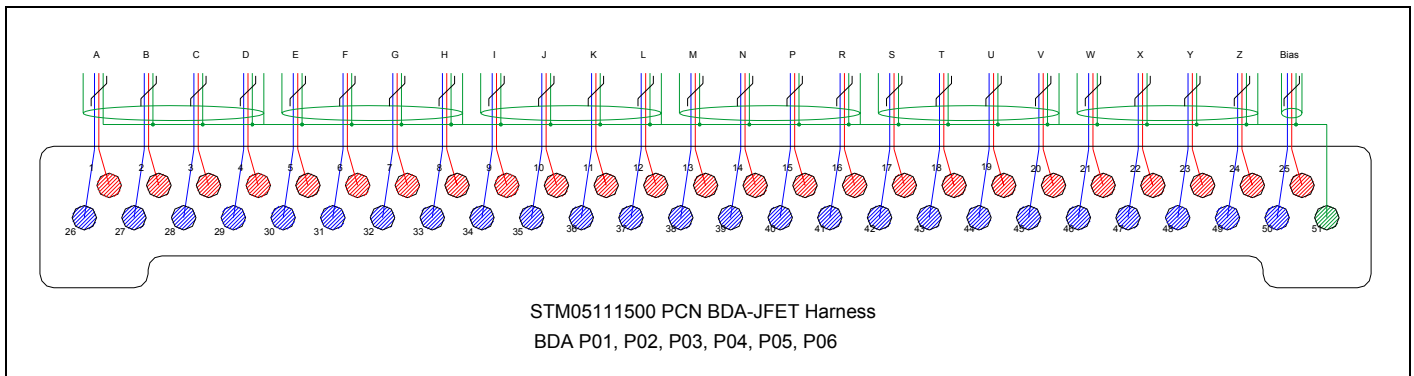

4.5.2 F2 PSW BDA J02 to HSJFP J30

See §4.5.1 F1 PSW BDA J01 to HSJFP

4.5.3 F3 PSW BDA J03 to HSJFP J31

See §4.5.1 F1 PSW BDA J01 to HSJFP

4.5.4 F4 PSW BDA J04 to HSJFP J32

See §4.5.1 F1 PSW BDA J01 to HSJFP

4.5.5 F5 PSW BDA J05 to HSJFP J33

See §4.5.1 F1 PSW BDA J01 to HSJFP

4.5.6 F6 PSW BDA J06 to HSJFP J34

See §4.5.1 F1 PSW BDA J01 to HSJFP

4.5.7 F7 PLW BDA J01 to HSJFP J35

Harnesses F7 & F8 passing from HSJFP to the PLW BDA are potted into a single feedthru mounted on the FPU Photometer Connector Bracket as illustrated below in the mechanical drawing.

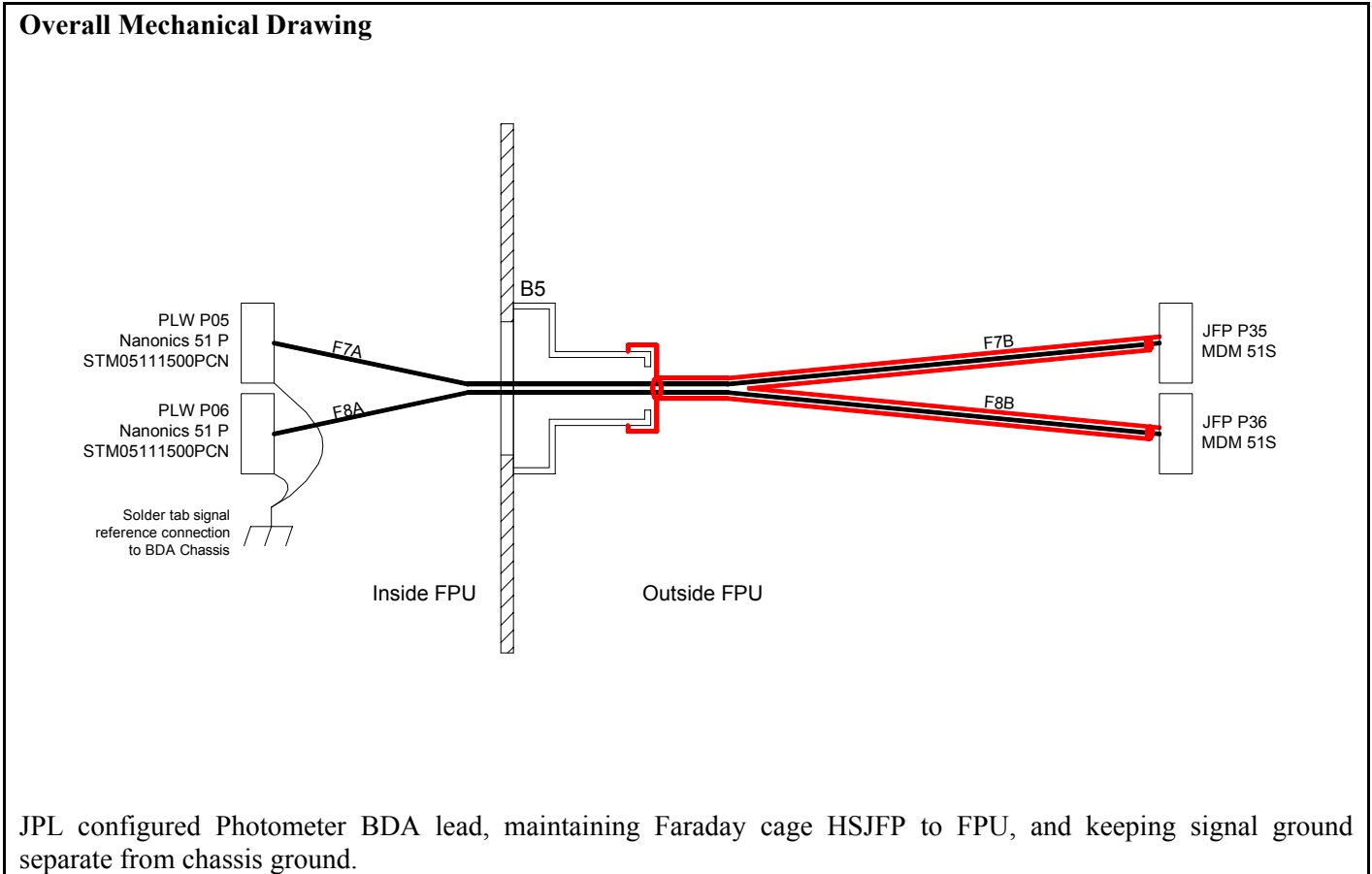

Connector/Backshell Details

A section: Nanonics STM05111500PCN with non RF-tight, potted backshell

B section: MDM51S with RF-tight, potted backshell

Harness Layup

B section requires outer RF shield, **A** section does not.

B section may have thermal heatsink attachments, TBD.

As F1, length a variable

Contact Details

as F1

4.5.8 F8 PLW BDA J02 to HSJFP J36

See §4.5.7 F7 PLW BDA J01 to HSJFP

4.5.9 F9 PMW BDA J01 to HSJFP J37

Harnesses F9 thru F12 passing from HSJFP to the PMW BDA are potted into a single feedthru mounted on the FPU Photometer Connector Bracket as illustrated below in the mechanical drawing.

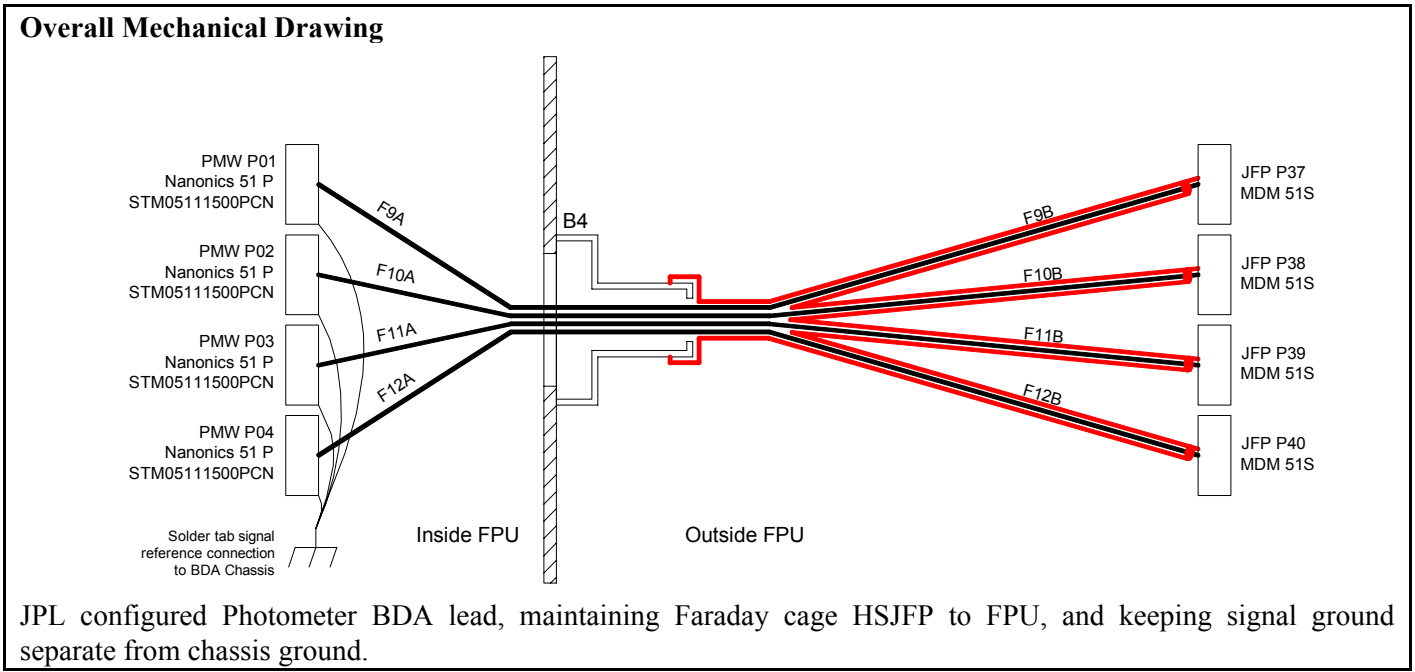

Connector/Backshell Details

A section: Nanonics STM05111500PCN with non RF-tight, potted backshell
B section: MDM51S with RF-tight, potted backshell

Harness Layup

B section requires outer RF shield, **A** section does not.
B section may have thermal heatsink attachments, TBD.

As F1, length a variable

Contact Details

as F1

4.5.10 F10 PMW BDA J02 to HSJFP to J38

See §4.5.9 F9 PMW BDA J01 to HSJFP

4.5.11 F11 PMW BDA J03 to HSJFP to J39

See §4.5.9 F9 PMW BDA J01 to HSJFP

4.5.12 F12 PMW BDA J04 to HSJFP to J40

See §4.5.9 F9 PMW BDA J01 to HSJFP

4.5.13 F13 SSW BDA J05 to HSJFS J11

Harnesses F13 thru F14 passing from HSJFS to the SSW BDA are potted into a single feedthru mounted on the FPU Photometer Connector Bracket as illustrated below in the mechanical drawing.

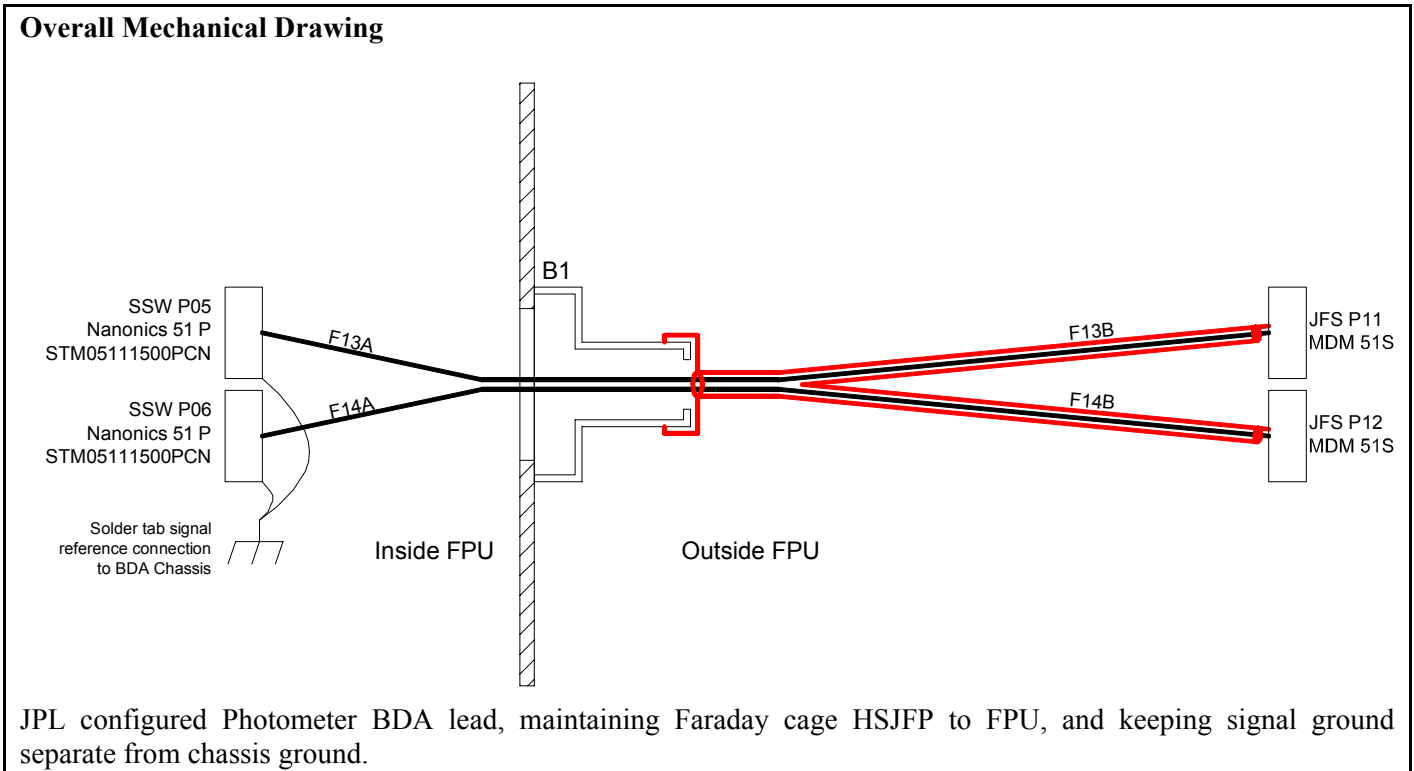

Connector/Backshell Details

A section: Nanonics STM05111500PCN with non RF-tight, potted backshell

B section: MDM51S with RF-tight, potted backshell

Harness Layup

B section requires outer RF shield, **A** section does not.

B section may have thermal heatsink attachments, TBD.

As F1, length a variable

Contact Details

as F1

4.5.14 F14 SSW BDA J06 to HSJFS J12

See §4.5.13 F13 SSW BDA J05 to HSJFS J11



SPIRE HARNESS DEFINITION DOCUMENT

Doc: SPIRE-RAL-PRJ-000608
 Issue: 1.2
 Date: 17/02/05
 Page 186 of 245

4.5.15 F15 SLW BDA J01 to HSJFS J13 (plus PTC Cold harnessing – F28)

Harnesses F15 A/B and F28 A/B passing from HSJFS to the SLW BDA and the PTC system respectively are potted into a single feedthru mounted on the FPU Photometer Connector Bracket as illustrated below in the mechanical drawing.

Overall Mechanical Drawing

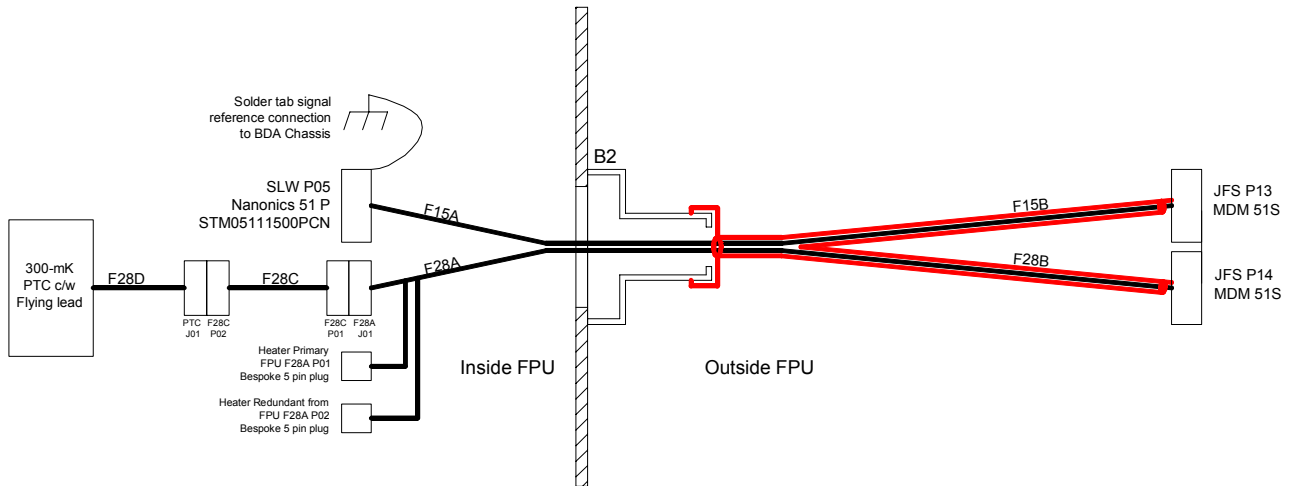

Connector/Backshell Details

- A section:** SLW P01, Nanonics STM05111500PCN with non RF-tight, potted backshell
 F28A J01, Nanonics STM02511500PCN with non RF-tight, potted backshell
 FPU F28A P01 and P02, bespoke 5-way inline connectors
- C Section:** FPU F28C P01, Nanonics STM02511500SCN
 FPU F28C P02, Nanonics STM05111500PCN
- B section:** MDM51S with RF-tight, potted backshell

Harness Layup

B section requires outer RF shield, A, C and D sections do not.

As F1, length a variable

Contact Details

For JFS P13 and SLW P05 as per F1

For F28A/B/C see §4.5.28 to §4.5.30 starting on Page 204 and the summary signal tracing table, Table 4.5-1- PTC Wiring Summary on Page 203 below.

4.5.16 F16 COOLER-P to FPU J19A

Overall Mechanical Drawing

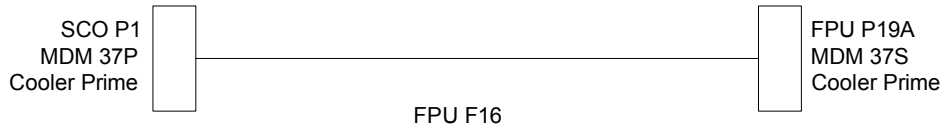

Harness routing as per RD-4, Sheet 3

Connector/Backshell Details

FPU P19A MDM 37S with potted EMI Backshell
 SCO P1 MDM 37P with potted EMI Backshell

The connector orientation at the cooler interface is defined in RD 3.

Harness Layup

- As per C10 FPU P19
 - Five 30AWG Copper STQ,
 - Three 30AWG Copper UTQ (may be STQ if more convenient)
- EMI braid over harness bundle terminated at the backshells
- No overall harness insulation required

4.5.17 F17 COOLER-R to FPU J20A

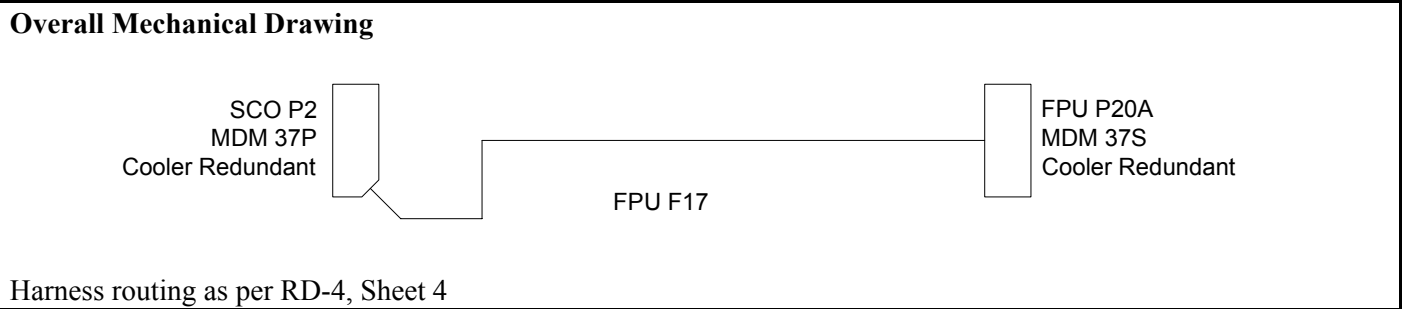

Connector/Backshell Details

FPU P20A MDM 37S with potted EMI Backshell
 SCO P2 MDM 37P with potted EMI Backshell

The connector orientation at the cooler interface is defined in RD 3.

- Harness Layup**
- As per C10 FPU P19
 - Five 30AWG Copper STQ,
 - Three 30AWG Copper UTQ (may be STQ if more convenient)
 - EMI braid over harness bundle terminated at the backshells
 - No overall harness insulation required

4.5.18 F18 SCaI-P to FPU J21A

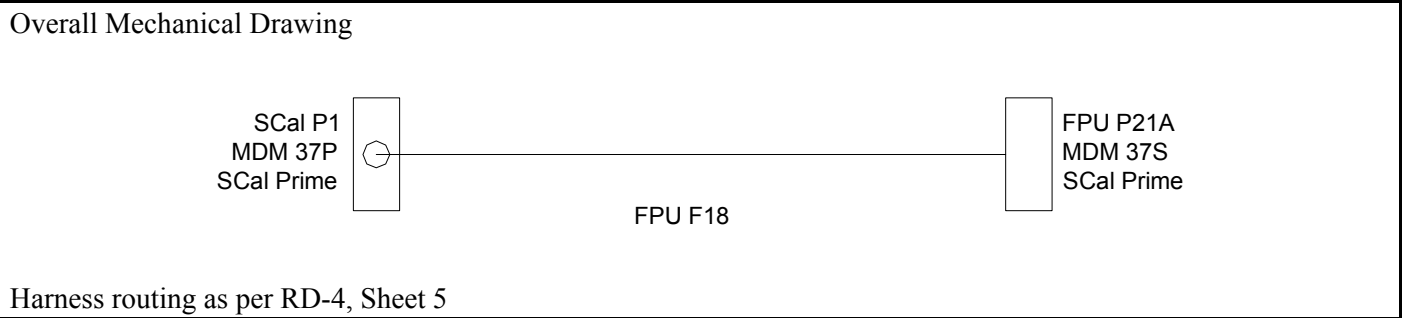

Connector/Backshell Details

FPU P21A MDM 37S with potted EMI Backshell
 SCaI P1 MDM 37P with potted EMI Backshell

- Harness Layup**
- As per C10 FPU P21
 - Three 30 AWG Copper STQ
 - Two 30 AWG Copper UTQ (may be STQ if more convenient)
 - EMI braid over harness bundle terminated at the backshells
 - No overall harness insulation required

Contact Details

4.5.19 F19 SCaI-R to FPU J22A

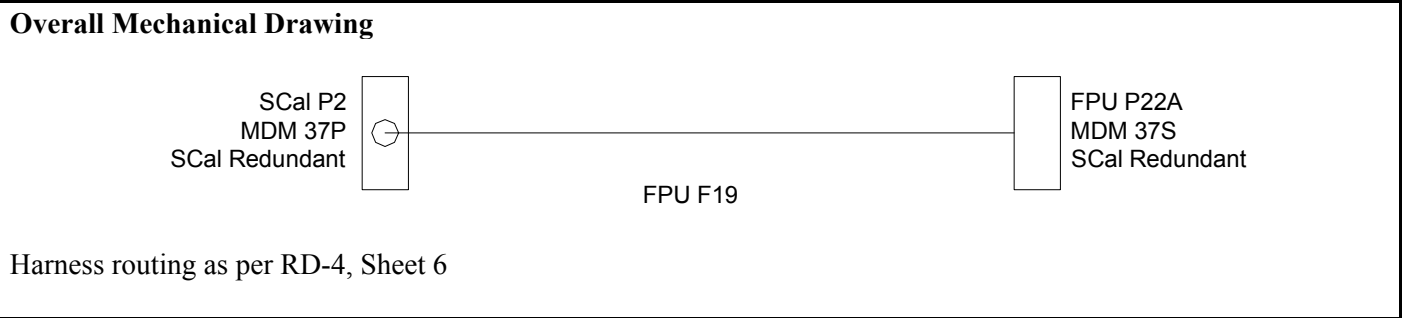

Connector/Backshell Details

FPU P22A MDM 37S with potted EMI Backshell
 SCaI P2 MDM 37P with potted EMI Backshell

- Harness Layup**
- As per C10 FPU P21
 - Three 30 AWG Copper STQ
 - Two 30 AWG Copper UTQ (may be STQ if more convenient)
 - EMI braid over harness bundle terminated at the backshells
 - No overall harness insulation required

Contact Details

4.5.20 F20 THERM-P to FPU J23A

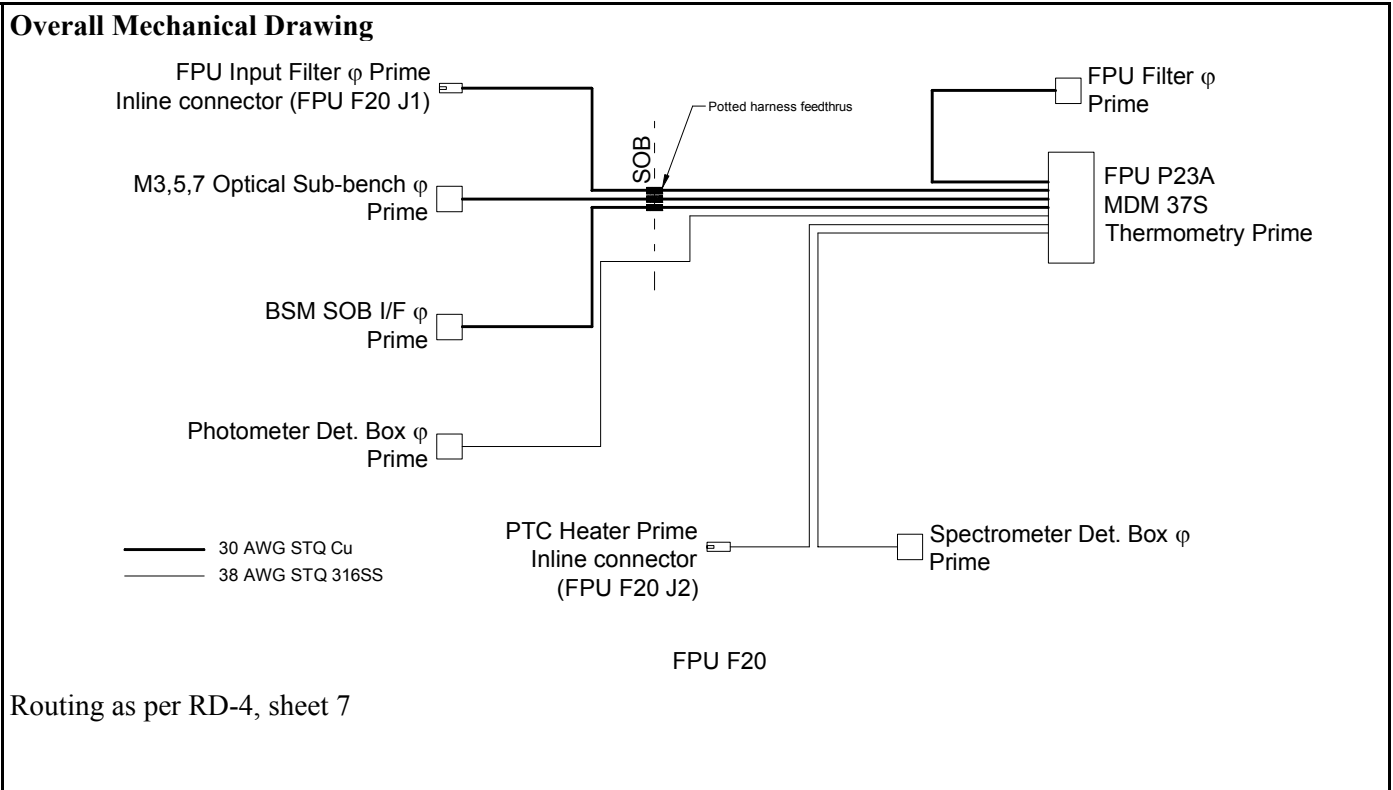

Connector/Backshell Details

FPU P23A MDM 37S with potted EMI Backshell
 Bespoke potted inline 5-Way connectors for Phot. Det. Box φ, PTC Heater and Spect. Det. Box φ

- Harness Layup**
- As per C10 FPU P23
 - Seven 28 AWG Copper STQ
 - Three of these become 38 AWG Stainless STQ
 - EMI braid over harness bundle terminated at the backshells
 - No overall harness insulation required



SPIRE HARNESS DEFINITION DOCUMENT

Doc: SPIRE-RAL-PRJ-000608
 Issue: 1.2
 Date: 17/02/05
 Page 192 of 245

Contact Details

FPU P23A terminated as per FPU P23.

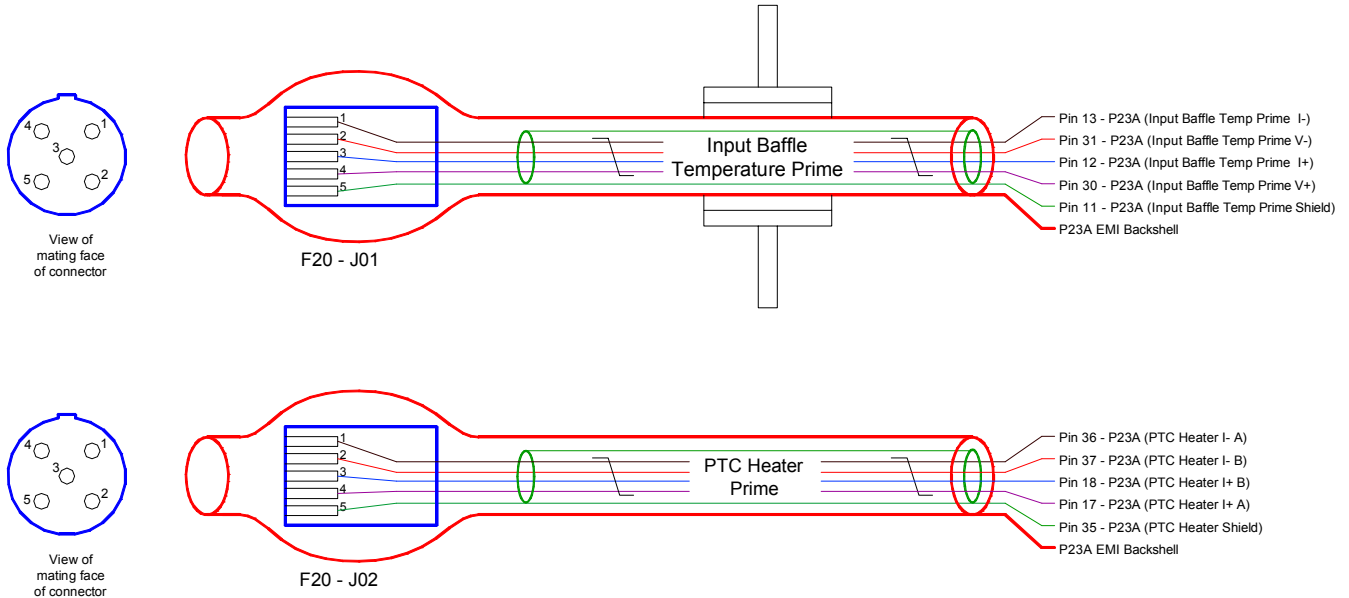

	FPU F20 Input baffle Temp Connectors		FPU F21 Input baffle Temp Connectors		FPU F29 Connectors			FPU F30 Connectors
	FPU P23A	F20 J01	FPU P24A	F21 J01	F29 P01	F29 P02	F29 J01	F30 J01
	MDM 37 Socket	Bespoke 5 pin Socket	MDM 37	Bespoke 5 pin Socket	Bespoke 5 pin Plug	Bespoke 5 pin Plug	MDM 15 Plug	MDM 15 Socket
Input Baffle Temp. Prime V+	30	4		-----	4	-----	1	1
Input Baffle Temp. Prime I+	12	3		-----	3	-----	2	2
Input Baffle Temp. Prime I-	13	1		-----	1	-----	10	10
Input Baffle Temp. Prime V-	31	2		-----	2	-----	9	9
Input Baffle Temp. Prime Shield	11	5		-----	5	-----	3	3
Input Baffle Temp. Red. V+	-----	-----	30	4	-----	4	6	6
Input Baffle Temp. Red. I+	-----	-----	12	3	-----	3	7	7
Input Baffle Temp. Red. I-	-----	-----	13	1	-----	1	15	15
Input Baffle Temp. Red. V-	-----	-----	31	2	-----	2	14	14
Input Baffle Temp. Red. Shield	-----	-----	11	5	-----	5	8	8

Figure 4-4 - Summary of connector terminations for Input Baffle ϕ bias and readout.

4.5.21 F21 THERM-R from FPU J24A

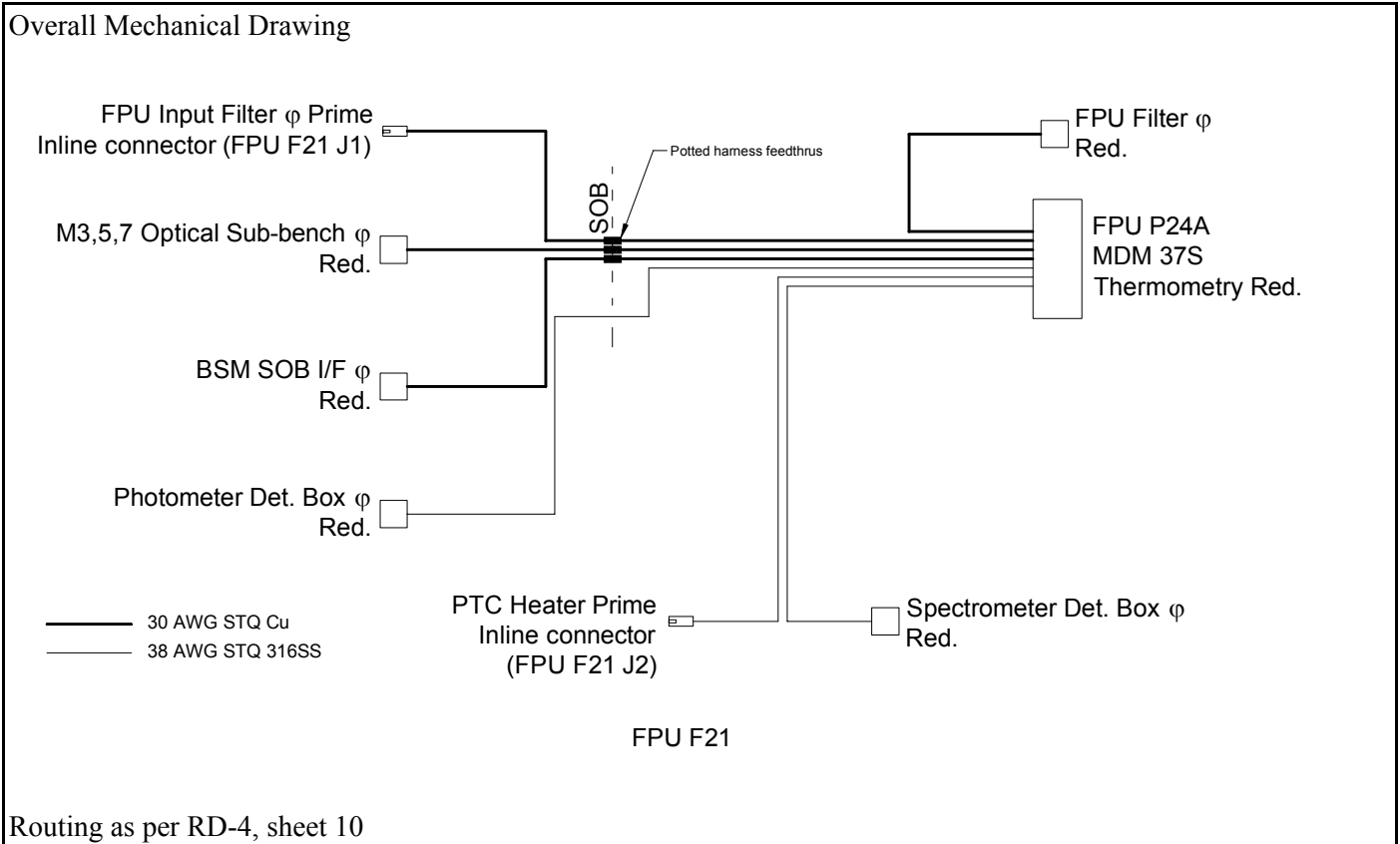

Connector/Backshell Details

FPU P24A MDM 37S with potted EMI Backshell
 Bespoke potted inline 5-Way connectors for Phot. Det. Box φ, PTC Heater and Spect. Det. Box φ

Harness Layup

- As per C10 FPU P23
 - Seven 28 AWG Copper STQ
 - Three of these become 38 AWG Stainless STQ
- EMI braid over harness bundle terminated at the backshells
- No overall harness insulation required



SPIRE HARNESS DEFINITION DOCUMENT

Doc: SPIRE-RAL-PRJ-000608
Issue: 1.2
Date: 17/02/05
Page 194 of 245

Contact Details

FPU P24A terminated as per FPU J23 (c.f. §4.4.10)

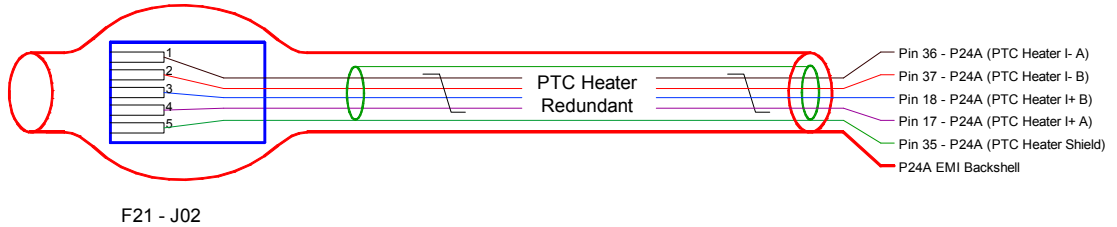
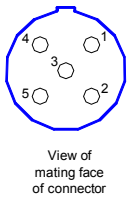
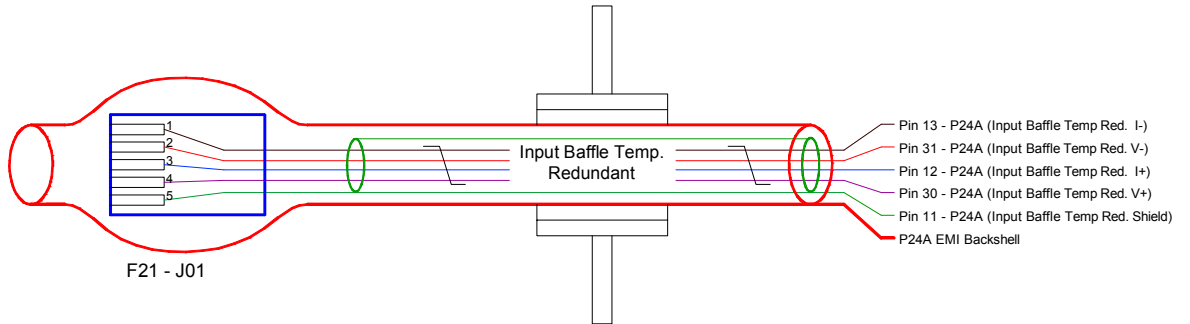
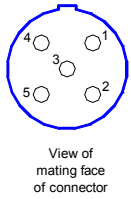

4.5.22 F22 BSM-P to FPU J25A

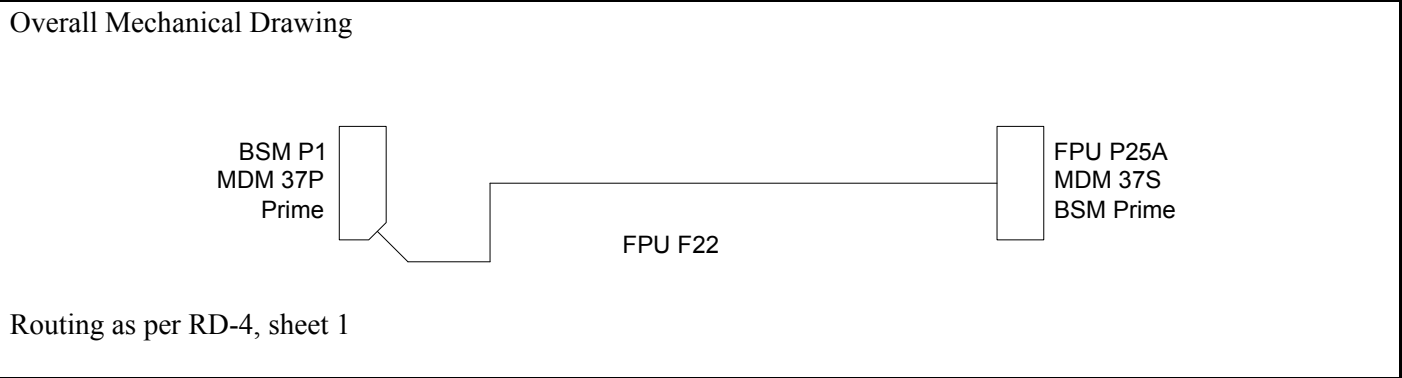

Connector/Backshell Details

MDM 37S with Potted EMI Backshell at Filter (FPU J25A)
 MDM 37P with Potted EMI Backshell at BSM (BSM J1)

Harness Layup

- As per C11 FPU P25
 - 4 30AWG Copper STP
 - 4 30 AWG Copper STQ
 - 2 30 AWG Copper STT
- EMI braid over harness bundle terminated at the backshells
- No overall harness insulation required

Contact Details

4.5.23 F23 BSM-R to FPU J26A

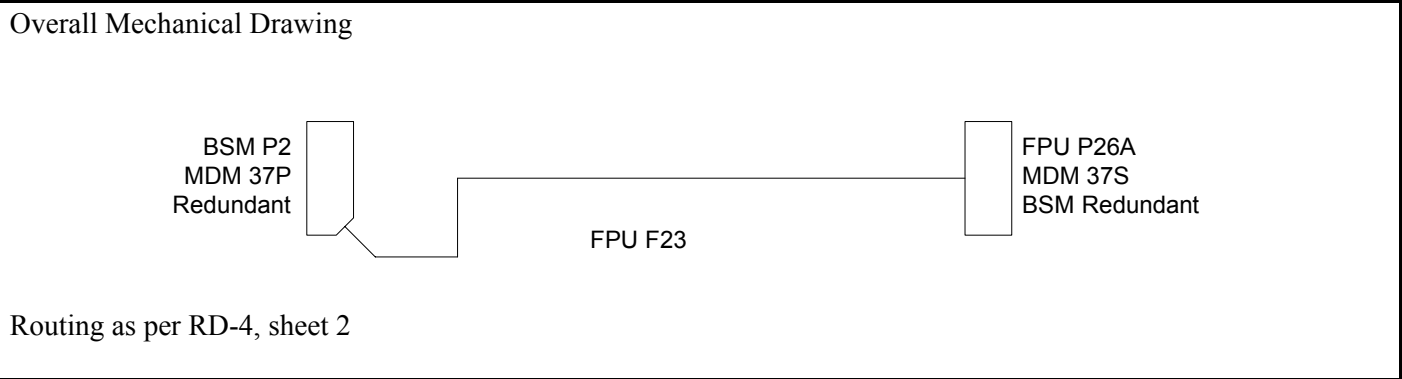

Connector/Backshell Details

MDM 37S with Potted EMI Backshell at Filter (FPU J26A)
 MDM 37P with Potted EMI Backshell at BSM (BSM J2)

- Harness Layup**
- As per C11 FPU P25
 - 4 30AWG Copper STP
 - 4 30 AWG Copper STQ
 - 2 30 AWG Copper STT
 - EMI braid over harness bundle terminated at the backshells
 - No overall harness insulation required

Contact Details

4.5.24 F24 SMEC Launch (Prime) connected to FPU J27A

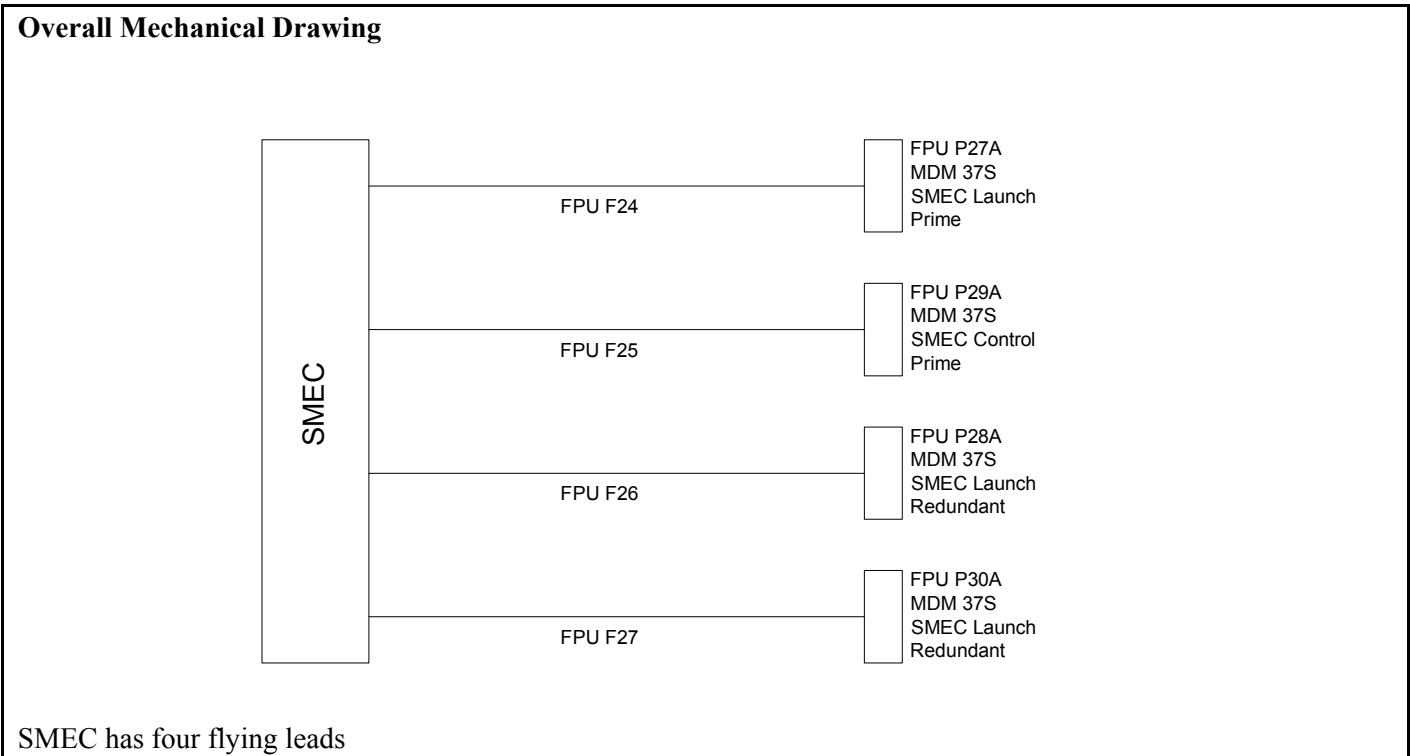

Connector/Backshell Details

FPU J27A MDM 37S with EMI backshell connected SMEC via a flying lead

Harness Layup

- As per C11 FPU P27
 - 9 30AWG Copper STP
 - 2 30AWG Copper STQ
- EMI braid over harness bundle terminated at the backshells
- No overall harness insulation required

Contact Details

4.5.25 F25 SMEC Control (Prime) connected to FPU J29A

Overall Mechanical Drawing

See 4.5.24 - F24 SMEC Launch

Connector/Backshell Details

FPU J29A MDM 37S with EMI backshell connected SMEC via a flying lead

- Harness Layup**
- As per C11 FPU P29
 - 11 30AWG STP
 - EMI braid over harness bundle terminated at the backshells
 - No overall harness insulation required

Contact Details

4.5.26 F26 SMEC Launch (Red.) connected to FPU J28A

Overall Mechanical Drawing

See 4.5.24 F24 SMEC Launch

Connector/Backshell Details

FPU J28A MDM 37S with EMI backshell connected SMEC via a flying lead

- Harness Layup**
- As per C11 FPU P27
 - 9 30AWG Copper STP
 - 2 30AWG Copper STQ
 - EMI braid over harness bundle terminated at the backshells
 - No overall harness insulation required

Contact Details

4.5.27 F27 SMEC Control (Red.) connected to FPU J30A

Overall Mechanical Drawing

See §4.5.24 F24 SMEC Launch

Connector/Backshell Details

FPU J30A MDM 37S with EMI backshell connected SMEC via a flying lead

- Harness Layup**
- As per C11 FPU P29
 - 11 30AWG STP
 - EMI braid over harness bundle terminated at the backshells
 - No overall harness insulation required

Contact Details



SPIRE HARNESS DEFINITION DOCUMENT

Doc: SPIRE-RAL-PRJ-000608
Issue: 1.2
Date: 17/02/05
Page 201 of 245

4.5.28 F28A and F28B Assembly – PTC (F28A J01 to HSJFS J14)

Overall Mechanical Drawing

See §4.5.15 F15 SLW BDA J01 to HSJFS J13

Connector/Backshell Details

25-Way Nanonics Plug to 51-Way MDM Socket at JFS

Harness Layup

No overshield used in on the portion of the harness inside the FPU. EMI Shield used outside FPU.

Contact Details

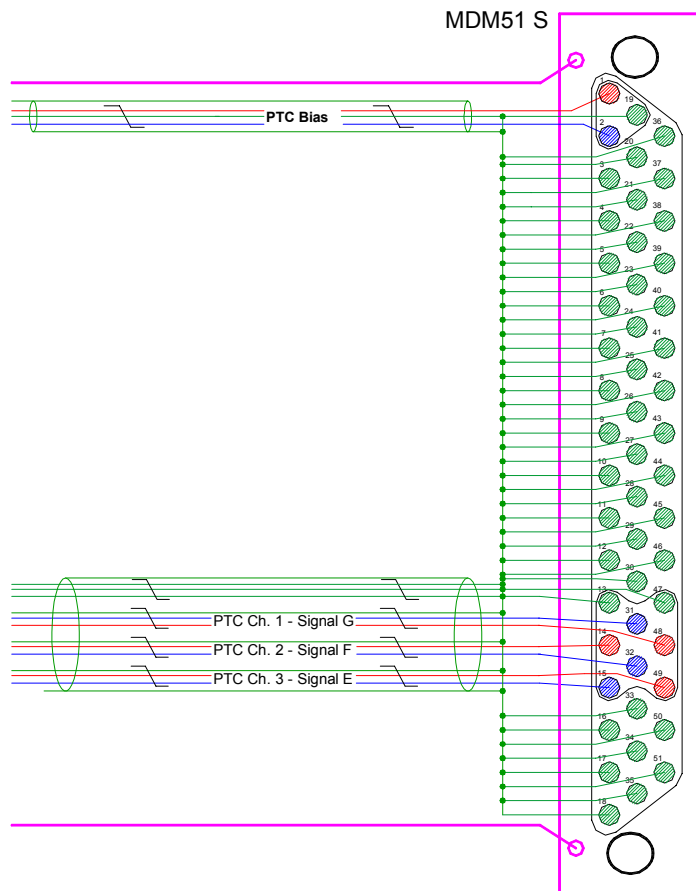

JFS J14

- One 12-ax (signals)
- One STT (Bias)



SPIRE HARNESS DEFINITION DOCUMENT

Doc: SPIRE-RAL-PRJ-000608

Issue: 1.2

Date: 17/02/05

Page 202 of 245

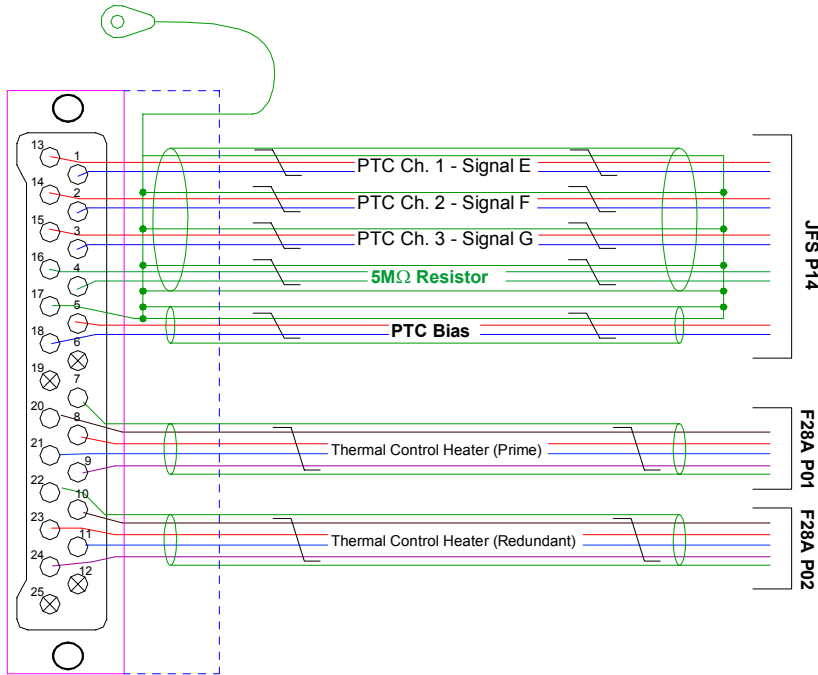

FPU F28A J01

- One 12-ax (signals)
- One STT (Bias)
- Two 38AWG SS STQ (Heaters)
- The 12-ax and the STT pass through FPU Feedthru B2 in the wall of the FPU and connect to JFS J14 (a 51-way MDM)
- The STQs terminate on 5-way Bespoke 1:1 connectors and join into F20 and F21
- each cable is jacketed

Nanonics STM02511500PCN (view of contacts)

F28A P01 - Pin 20 (PTC Heater I+ A)
 F28A P01 - Pin 08 (PTC Heater I- A)
 F28A P01 - Pin 21 (PTC Heater I+ B)
 F28A P01 - Pin 09 (PTC Heater I- B)
 F28A P01 - Pin 07 (PTC Heater Shield)

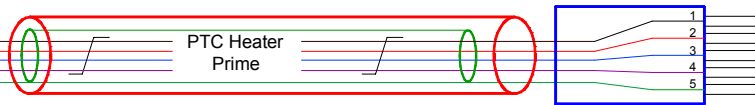

F28A P01

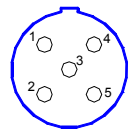

View of mating face of connector

F28A P02 - Pin 20 (PTC Heater I- A)
 F28A P02 - Pin 08 (PTC Heater I- B)
 F28A P02 - Pin 21 (PTC Heater I+ B)
 F28A P02 - Pin 09 (PTC Heater I+ A)
 F28A P02 - Pin 22 (PTC Heater Shield)

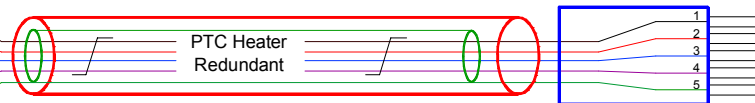

F28A P02

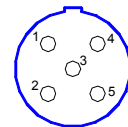

View from mating face of connector



SPIRE HARNESS DEFINITION DOCUMENT

Doc: SPIRE-RAL-PRJ-000608
Issue: 1.2
Date: 17/02/05
Page 203 of 245

		PTC Related Connectors on F28A				PTC Related Connectors on F20		PTC Related Connectors on F21		F28 C Connectors		F28D Connectors
		JFS P14	F28A J01	F28A P01	F28A J02	FPU P23A	F20 J02	FPU P24A	F21 J02	F28C P01	F28C P02	PTC J01
		MDM 51	25-Way Nanonics	Bespoke 5 Pin	Bespoke 5 Pin	MDM 37	Bespoke 5 Pin	MDM 37	Bespoke 5 Pin	25-Way Nanonics	51-Way Nanonics	51-Way Nanonics
		Socket	Plug	Plug	Plug	Socket	Socket	Socket	Socket	Socket	Plug	Socket
NTD Thermometry Signals 12-ax	PTC Ch E+	49	13	~~~~~	~~~~~	~~~~~	~~~~~	~~~~~	~~~~~	13	10, 34	10, 34
	PTC Ch E-	15	1	~~~~~	~~~~~	~~~~~	~~~~~	~~~~~	~~~~~	1	14, 38	14, 38
	PTC Ch. E Triplet Ground	GND Busbar	17	~~~~~	~~~~~	~~~~~	~~~~~	~~~~~	~~~~~	17	51	51
	PTC Ch F+	14	14	~~~~~	~~~~~	~~~~~	~~~~~	~~~~~	~~~~~	14	16, 40	16, 40
	PTC Ch F-	32	2	~~~~~	~~~~~	~~~~~	~~~~~	~~~~~	~~~~~	2	19, 44	19, 44
	PTC Ch. F Triplet Ground	GND Busbar	17	~~~~~	~~~~~	~~~~~	~~~~~	~~~~~	~~~~~	17	51	51
	PTC Ch G+	48	15	~~~~~	~~~~~	~~~~~	~~~~~	~~~~~	~~~~~	15	21, 46	21, 46
	PTC Ch G-	31	3	~~~~~	~~~~~	~~~~~	~~~~~	~~~~~	~~~~~	3	24, 49	24, 49
PTC Ch. G Triplet Ground	GND Busbar	17	~~~~~	~~~~~	~~~~~	~~~~~	~~~~~	~~~~~	17	51	51	
PTC Spare Triplet	13, 47 + GND Busbar	4, 16, 17	~~~~~	~~~~~	~~~~~	~~~~~	~~~~~	~~~~~	4, 16, 17	51	51	
NTD Bias STT	PTC Bias +	1	5	~~~~~	~~~~~	~~~~~	~~~~~	~~~~~	~~~~~	5	11, 17, 22, 35, 41, 47	11, 17, 22, 35, 41, 47
	PTC Bias -	2	18	~~~~~	~~~~~	~~~~~	~~~~~	~~~~~	~~~~~	18	13, 18, 23, 37, 43, 48	13, 18, 23, 37, 43, 48
	PTC Bias Ground	GND Busbar	4, 16, 17	~~~~~	~~~~~	~~~~~	~~~~~	~~~~~	~~~~~	4, 16, 17	51	51
Prime Heater STQ	PTC Heater Prime I+ A	~~~~~	20	4	~~~~~	17	4	~~~~~	~~~~~	20	26, 50	26, 50
	PTC Heater Prime I+ B	~~~~~	21	3	~~~~~	18	3	~~~~~	~~~~~	21	26, 50	26, 50
	PTC Heater Prime I- A	~~~~~	8	1	~~~~~	36	1	~~~~~	~~~~~	8	31, 32	31, 32
	PTC Heater Prime I- B	~~~~~	9	2	~~~~~	37	2	~~~~~	~~~~~	9	31, 32	31, 32
	PTC Heater Prime STQ Shield	~~~~~	7	5	~~~~~	35	5	~~~~~	~~~~~	7	NC	NC
Red. Heater STQ	PTC Heater Red. I+ A	~~~~~	10	~~~~~	4	~~~~~	17	4	~~~~~	10	1, 25	1, 25
	PTC Heater Red. I+ B	~~~~~	11	~~~~~	3	~~~~~	18	3	~~~~~	11	1, 25	1, 25
	PTC Heater Red. I- A	~~~~~	23	~~~~~	1	~~~~~	36	1	~~~~~	23	5, 6	5, 6
	PTC Heater Red. I- B	~~~~~	24	~~~~~	2	~~~~~	37	2	~~~~~	24	5, 6	5, 6
	PTC Heater Red. STQ Shield	~~~~~	22	~~~~~	5	~~~~~	35	5	~~~~~	22	NC	NC

Table 4.5-1- PTC Wiring Summary



SPIRE HARNESS DEFINITION DOCUMENT

Doc: SPIRE-RAL-PRJ-000608
Issue: 1.2
Date: 17/02/05
Page 204 of 245

4.5.29 F28C PTC (F28C P01 to F29C P02)

Overall Mechanical Drawing

See §4.5.15 F15 SLW BDA J01 to HSJFS J13

Connector/Backshell Details

25-Way Nanonics Socket to 51-Way Nanonics plug

Harness Layup

One 12-ax
One STT
Two STQ

No overshield

Contact Details

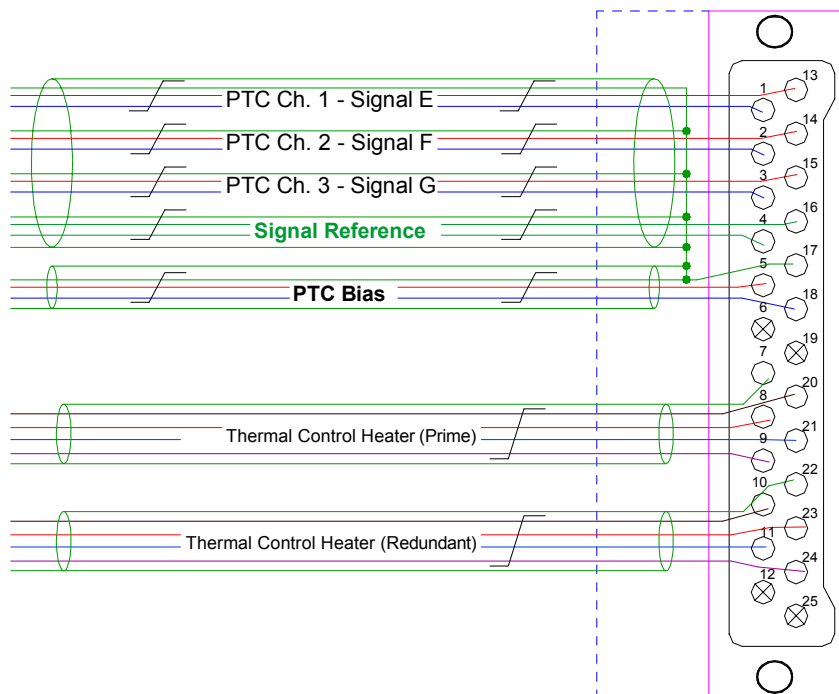

FPU F28C P01

- One 12-ax (signals)
- One STT (Bias)
- Two 38AWG SS STQ (Heaters)
- each cable is jacketed

Nanonics
STM02511500SCN
(view of contacts)



SPIRE HARNESS DEFINITION DOCUMENT

Doc: SPIRE-RAL-PRJ-000608
 Issue: 1.2
 Date: 17/02/05
 Page 205 of 245

Nanonics STM05111500PCN (view of contacts)

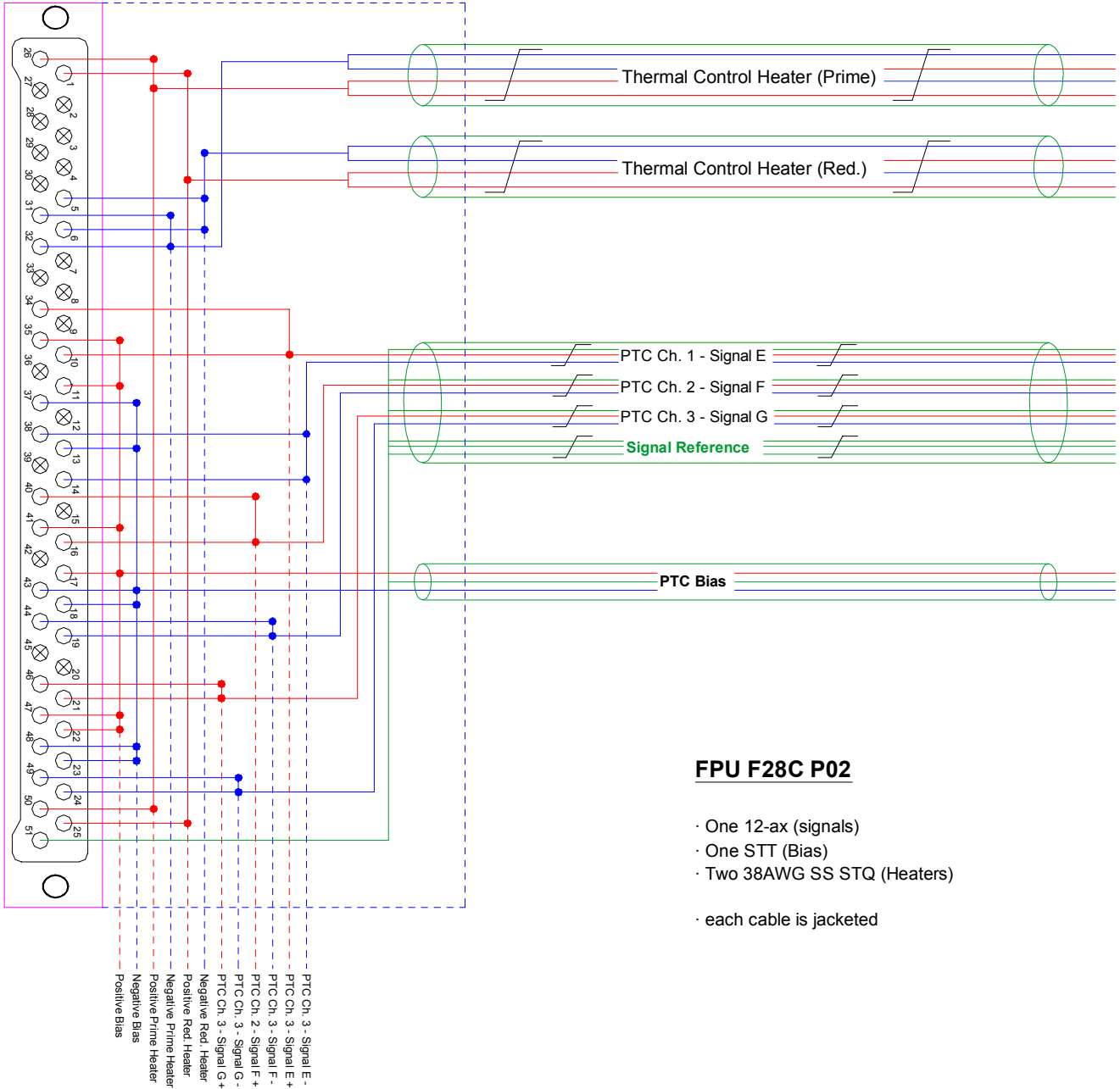

4.5.30 F28D PTC J01

Flying lead from 300-mK PTC to 51-way Nanonics socket (STM051M6SN)

Termination as per F28C P02



SPIRE HARNESS DEFINITION DOCUMENT

Doc: SPIRE-RAL-PRJ-000608

Issue: 1.2

Date: 17/02/05

Page 207 of 245

4.5.31 F29 Input Baffle Thermometry (Feedthru to SOB/Cover)

Overall Mechanical Drawing

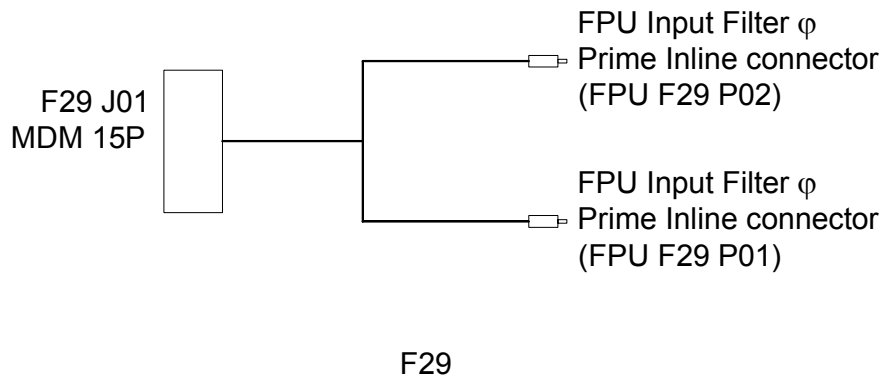

F29 J01 is secured on a floating mount on the SOB with guide pins to ensure alignment of F30 P01 during engagement.

Harness Layup

Two STQ, 30 AWG Cu

Contact Details

F29 J01 - MDM 15P

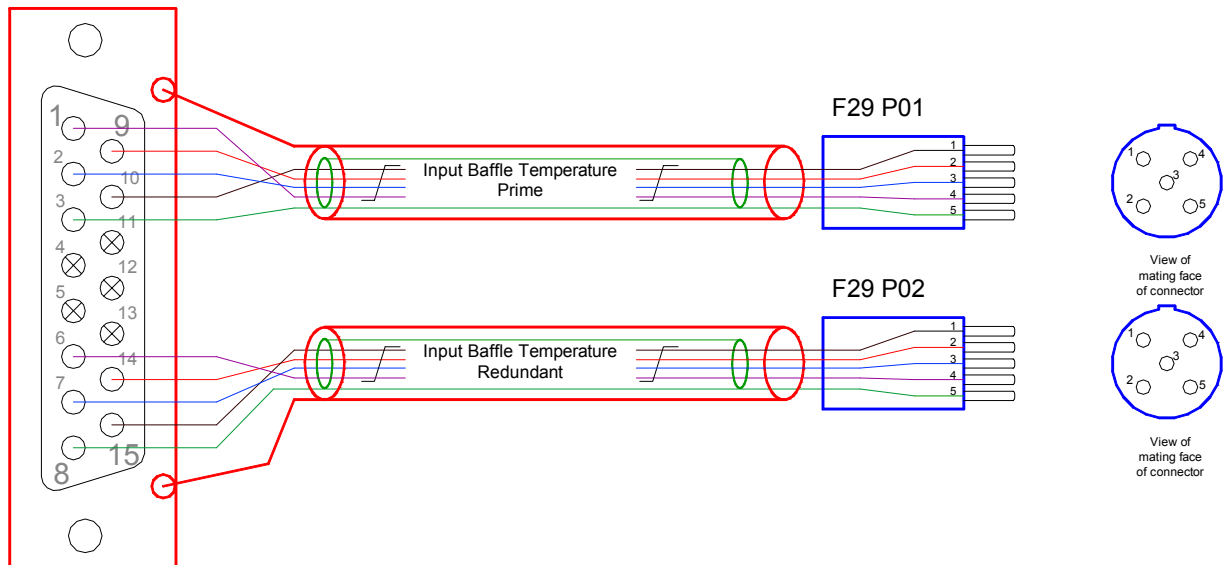

4.5.32 F30 Input Baffle Thermometry (SOB/Cover to Sensor)

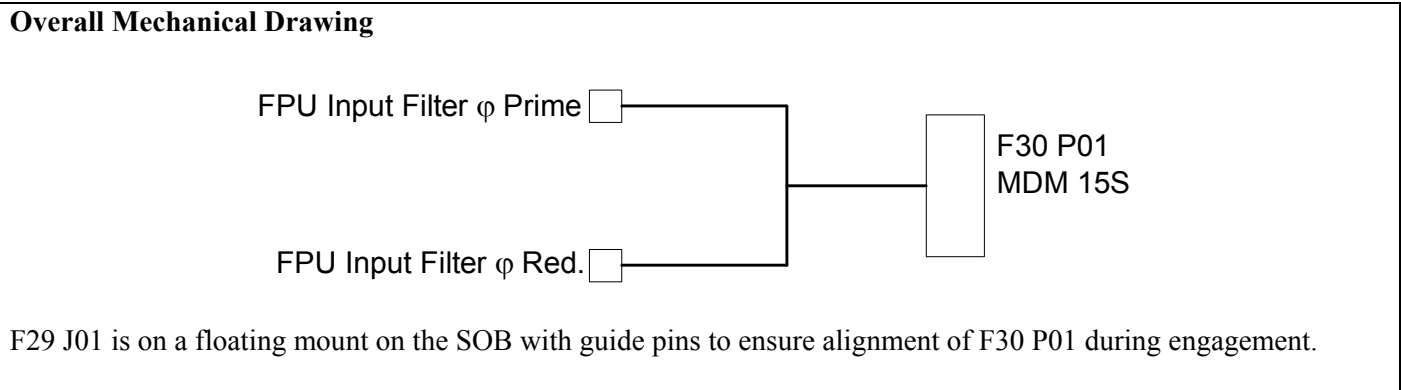

Harness Layup

Two STQ, 30 AWG Cu

Contact Details

As per F20 J01

4.6 JFET unit Back-Harnesses

4.6.1 Overview

Updated to reflect removal of separate RF filter units from baseline as in SPIRE Instrument Block Diagram 3.1 and following.

The Bolometer Back Harness provides the routing of wires from the JFET membrane 15way "service" connectors into the 37way connectors on harnesses C3 and half of C1.

The JFET 15ways each provide 7 double-wired functions on 14 pins as follows; all DC isolated from ground in the JFET box chassis except for 1MOhm antistatic resistors:

Function	A-wire	B-wire	These colour codes are carried through to the drawing below Values agree with 30/7/01 JPL review
JFET V +	10	14	
JFET V-	1	8	
JFET Vgnd	9	15	
Bias +	2	7	
Bias -	4	5	
Heater +	3	6	
Heater -	11	13	

For the photometer, the 4 x 37 = 148 C3 harness contacts cannot accommodate all the 12 x 14 =168 contacts from the JFET boxes. However not all these possible 168 at the 37 way filters can proceed through the 100(128) ways available in the C3 harness. A similar situation applies for the spectrometer. Appropriate commoning is build into splices in the BS and BP harnesses as shown in the diagram that follows: JPL consider this acceptable in copper multistrand harness and it avoids adaptor modules.

There is no splicing of functionality in the C or I series cryoharnesses. [Note that as specified earlier herein inner screens are linked in groups to reduce noise and not every inner shield proceeds on to a contact].

The philosophy of deciding which how to common up the functions in these harnesses was decided in issue 0.3 of this document with a view to failure control. If the supposedly impossible happened and both the A and B wires of a particular function were to break, that function should not take out a complete BDA array. This is accomplished on 4 BDAs by allocating them more than a single function, whilst on the 5th, one, the small SLW BDA, there is enough spare pin capacity to double up the wiring again. This provides the HSDCU with as many separately wired a.c. bias generator wires as can be fitted through the harnesses C/I3 and half of C/I1. Bias generator wiring may be paralleled on entry to the HSDCU, and the present baseline of just one powered bias generator scalar / O/P for each bolometer array results in just this.

Looking at the table above*, note that the A and B wires for each of these functions must be linked in the HSDCU to maintain cryoharness robustness against single wire breakage, *whether or not* they then split into two again and feed into Prime and Redundant DCU electronics functions. The A and B wires do not follow each other in the same harness tail and get linked inside the harness itself at the HSDCU because any mechanical distress to the cryoharness is likely to be on a tail-by-tail (connector-by-connector) basis and one does not want both the A and B wires of any function broken. They are bundled close together as shown in the SPIRE Instrument Block Diagram to minimise loop areas.

*Strictly speaking this paragraph applies to the grouped functions that get through the 37way linking, but it remains true for any particular BDA looking into the wiring.



SPIRE HARNESS DEFINITION DOCUMENT

Doc: SPIRE-RAL-PRJ-000608

Issue: 1.2

Date: 17/02/05

Page 210 of 245

14 wires, colour coded as in table above leave each JFET module. A-wires are drawn out. B-wires are identical and feed from here into the other backharness connectors

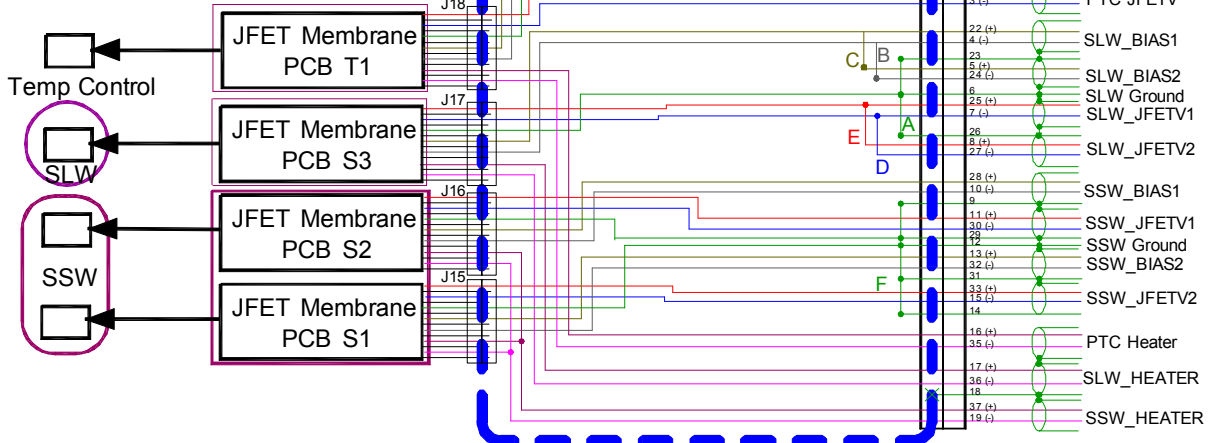

Half of C1

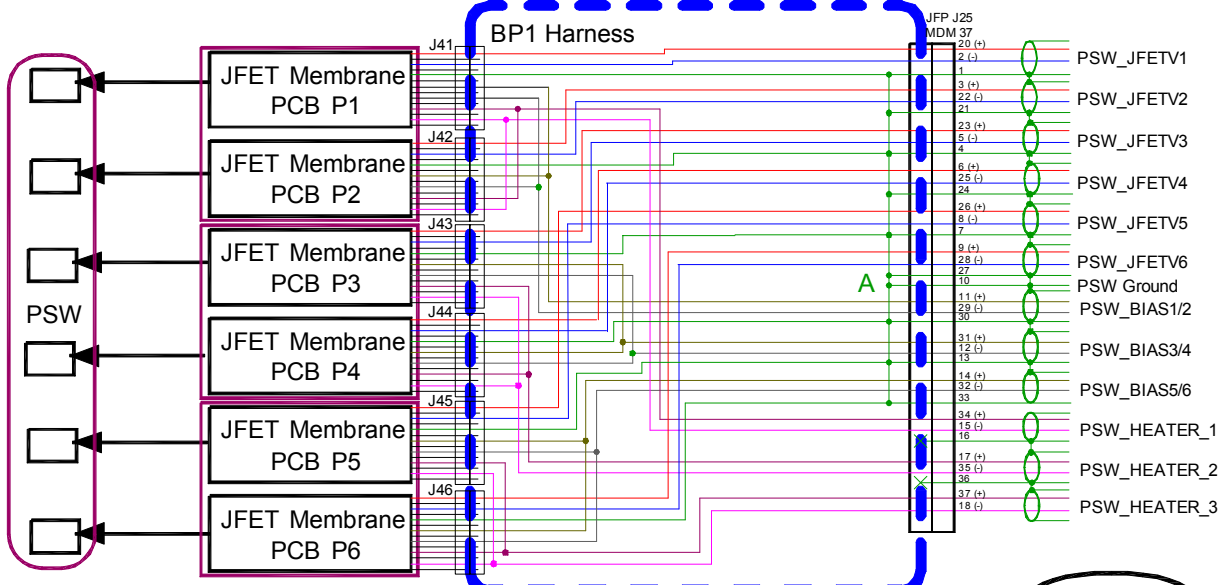

Half of C3

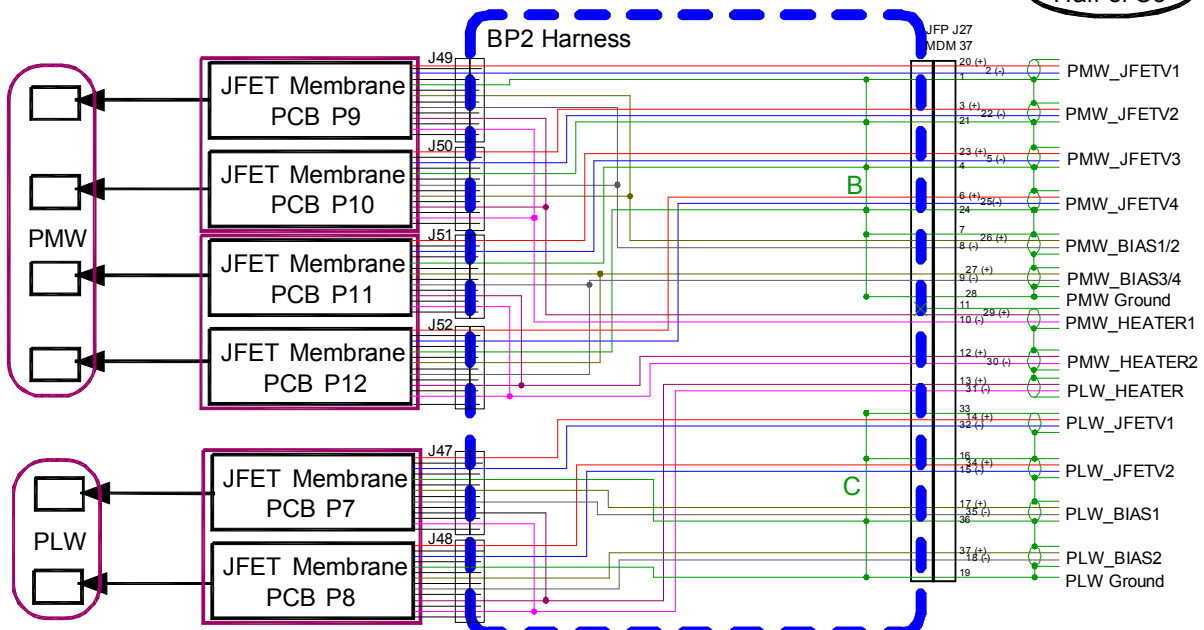



SPIRE HARNESS DEFINITION DOCUMENT

Doc: SPIRE-RAL-PRJ-000608
Issue: 1.2
Date: 17/02/05
Page 211 of 245

4.6.2 BP-Photometer

Overall Mechanical Drawing

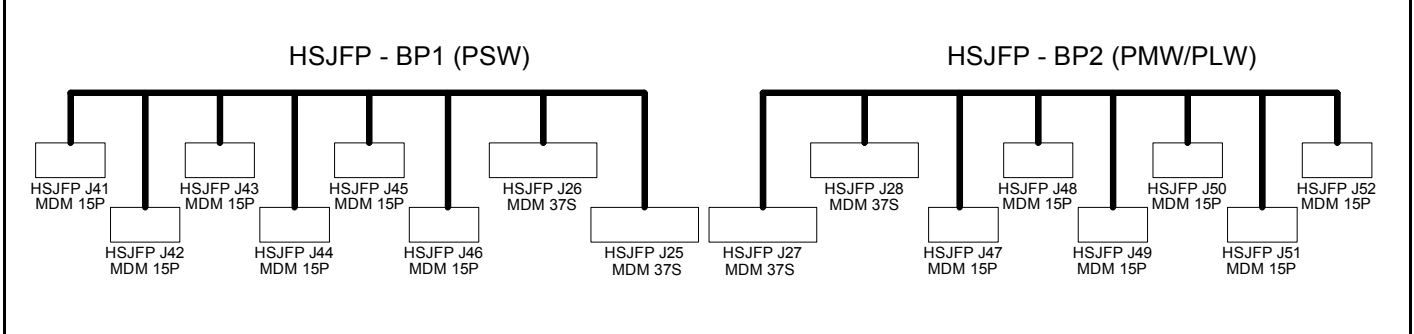

Connector/Backshell Details

JPL to specify.

Harness Layup

The BP harness is isothermal. Crimped 28AWG copper MDM

Pairs of wires should at least be twisted, and some inter-function screens may be appropriate, JPL to specify.

This is definitely a harness to build on a dimensionally accurate horse!

Contact Details

Assigning grounds end to end in this harness is somewhat arbitrary because

- i. Within the PSW Backplane Harness pins 1, 21, 4, 24, 7, 27, 10, 30, 13, 33 on the 37 Way connectors J25 are commoned as a PSW ground. These contacts are denoted by A in the table below.
- ii. Within the PMW/PLW Backplane Harness pins 1, 22, 4, 24, 7, 28 on the 37 Way connectors J26 are commoned as a PMW ground. These contacts are denoted by B in the table below.
- iii. Within the PMW/PLW Backplane Harness pins 33, 16, 36, 19 on the 37 Way connectors J26 are commoned as a PLW ground. These contacts are denoted by C in the table below.
- iv. The wires within these harnesses are doubled up to improve the system robustness. The same pattern of commoning the pins in the J27/J28 harnesses for the PSW, PMW and PLW grounds is adopted and are denoted by A', B' and C'



SPIRE HARNESS DEFINITION DOCUMENT

Doc: SPIRE-RAL-PRJ-000608

Issue: 1.2

Date: 17/02/05

Page 212 of 245

4.6.2.1 HSJFP – BP1 (PSW)

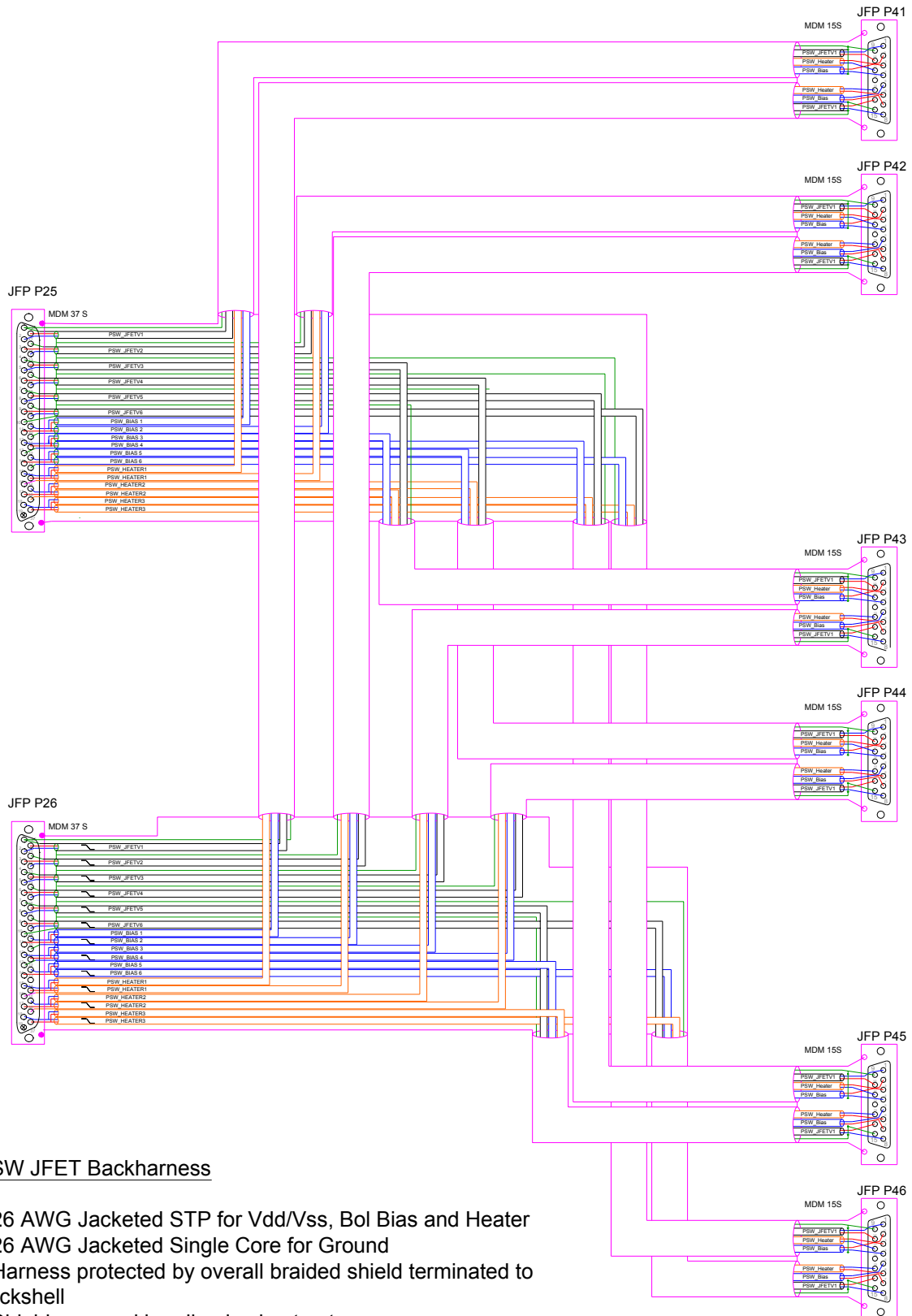

PSW JFET Backharness

- * 26 AWG Jacketed STP for Vdd/Vss, Bol Bias and Heater
- * 26 AWG Jacketed Single Core for Ground
- * Harness protected by overall braided shield terminated to backshell
- * Shield wrapped in adhesive kapton tape



SPIRE HARNESS DEFINITION DOCUMENT

Doc: SPIRE-RAL-PRJ-000608
Issue: 1.2
Date: 17/02/05
Page 213 of 245

Contact Details

Name	HSJFP		PSW Backplane Harness						
	JFP J25 MDM 37	JFP J26 MDM 37	HSJFP BP1						
			JFP J41 MDM 15 PSW	JFP J42 MDM 15 PSW	JFP J43 MDM 15 PSW	JFP J44 MDM 15 PSW	JFP J45 MDM 15 PSW	JFP J46 MDM 15 PSW	
PSW_JFETV1_A +	20		10						
PSW_JFETV1_A -	2		1						
PSW_JFETV1_A shld	1		9 (A)						
PSW_JFETV2_A +	3			10					
PSW_JFETV2_A -	22			1					
PSW_JFETV2_A shld	21		A						
PSW_JFETV3_A +	23				10				
PSW_JFETV3_A -	5				1				
PSW_JFETV3_A shld	4			9(A)					
PSW_JFETV4_A +	6					10			
PSW_JFETV4_A -	25					1			
PSW_JFETV4_A shld	24		A						
PSW_JFETV5_A +	26						10		
PSW_JFETV5_A -	8						1		
PSW_JFETV5_A shld	7				9(A)				
PSW_JFETV6_A +	9								10
PSW_JFETV6_A -	28								1
PSW_JFETV6_A shld	27		A						
PSW_GRND_A	10		A						
PSW_BIAS1/2_A +	11		2	2					
PSW_BIAS1/2_A -	29		4	4					
PSW_BIAS1/2_A shld	30					9(A)			
PSW_BIAS3/4_A +	31				2	2			
PSW_BIAS3/4_A -	12				4	4			
PSW_BIAS3/4_A shld	13						9(A)		
PSW_BIAS5/6_A +	14						2	2	
PSW_BIAS5/6_A -	32						4	4	
PSW_BIAS5/6_A shld	33								9(A)
PSW_HEATER_A1 +	34		3	3					
PSW_HEATER_A1 -	15		11	11					
PSW_HEATER_A1 shld	16		No Connection						
PSW_HEATER_A2 +	17				3	3			
PSW_HEATER_A2 -	35				11	11			
PSW_HEATER_A2 shld	36		No Connection						
PSW_HEATER_A3 +	37						3	3	
PSW_HEATER_A3 -	18						11	11	
PSW_HEATER_A3 shld	36		No Connection						
PSW_JFETV1_B +		20	14						
PSW_JFETV1_B -		2	8						
PSW_JFETV1_B shld		1	15(A')						
PSW_JFETV2_B +		3		14					
PSW_JFETV2_B -		22		8					
PSW_JFETV2_B shld		21	A'						
PSW_JFETV3_B +		23			14				
PSW_JFETV3_B -		5			8				
PSW_JFETV3_B shld		4		15(A')					
PSW_JFETV4_B +		6				14			
PSW_JFETV4_B -		25				8			
PSW_JFETV4_B shld		24	A'						
PSW_JFETV5_B +		26					14		



SPIRE HARNESS DEFINITION DOCUMENT

Doc: SPIRE-RAL-PRJ-000608
 Issue: 1.2
 Date: 17/02/05
 Page 214 of 245

Name	HSJFP		PSW Backplane Harness						
	JFP J25 MDM 37	JFP J26 MDM 37	HSJFP BP1						
			JFP J41 MDM 15 PSW	JFP J42 MDM 15 PSW	JFP J43 MDM 15 PSW	JFP J44 MDM 15 PSW	JFP J45 MDM 15 PSW	JFP J46 MDM 15 PSW	
PSW_JFETV5_B -		8						8	
PSW_JFETV5_B shld		7			15(A')				
PSW_JFETV6_B +		9							14
PSW_JFETV6_B -		28							8
PSW_JFETV6_B shld		27	A'						
PSW_GRND_B		10	A'						
PSW_BIAS1/2_B +		11	7	7					
PSW_BIAS1/2_B -		29	5	5					
PSW_BIAS1/2_B shld		30				15(A')			
PSW_BIAS3/4_B +		31			7	7			
PSW_BIAS3/4_B -		12			5	5			
PSW_BIAS3/4_B shld		13					15(A')		
PSW_BIAS5/6_B +		14					7	7	
PSW_BIAS5/6_B -		32					5	5	
PSW_BIAS5/6_B shld		33							15(A')
PSW_HEATER_B1 +		34	6	6					
PSW_HEATER_B1 -		15	13	13					
PSW_HEATER_B1 shld		16	No Connection						
PSW_HEATER_B2 +		17			6	6			
PSW_HEATER_B2 -		35			13	13			
PSW_HEATER_B2 shld		36	No Connection						
PSW_HEATER_B3 +		37					6	6	
PSW_HEATER_B3 -		18					13	13	
PSW_HEATER_B3 shld		36	No Connection						

Note A: Commoned with HSJFP J25 pins 1, 21, 4, 24, 7, 27, 10, 30, 13, 33

Note A': Commoned with HSJFP J26 pins 1, 21, 4, 24, 7, 27, 10, 30, 13, 33



SPIRE HARNESS DEFINITION DOCUMENT

Doc: SPIRE-RAL-PRJ-000608

Issue: 1.2

Date: 17/02/05

Page 215 of 245

4.6.2.2 HSJFP – BP2 (PMW/PLW)

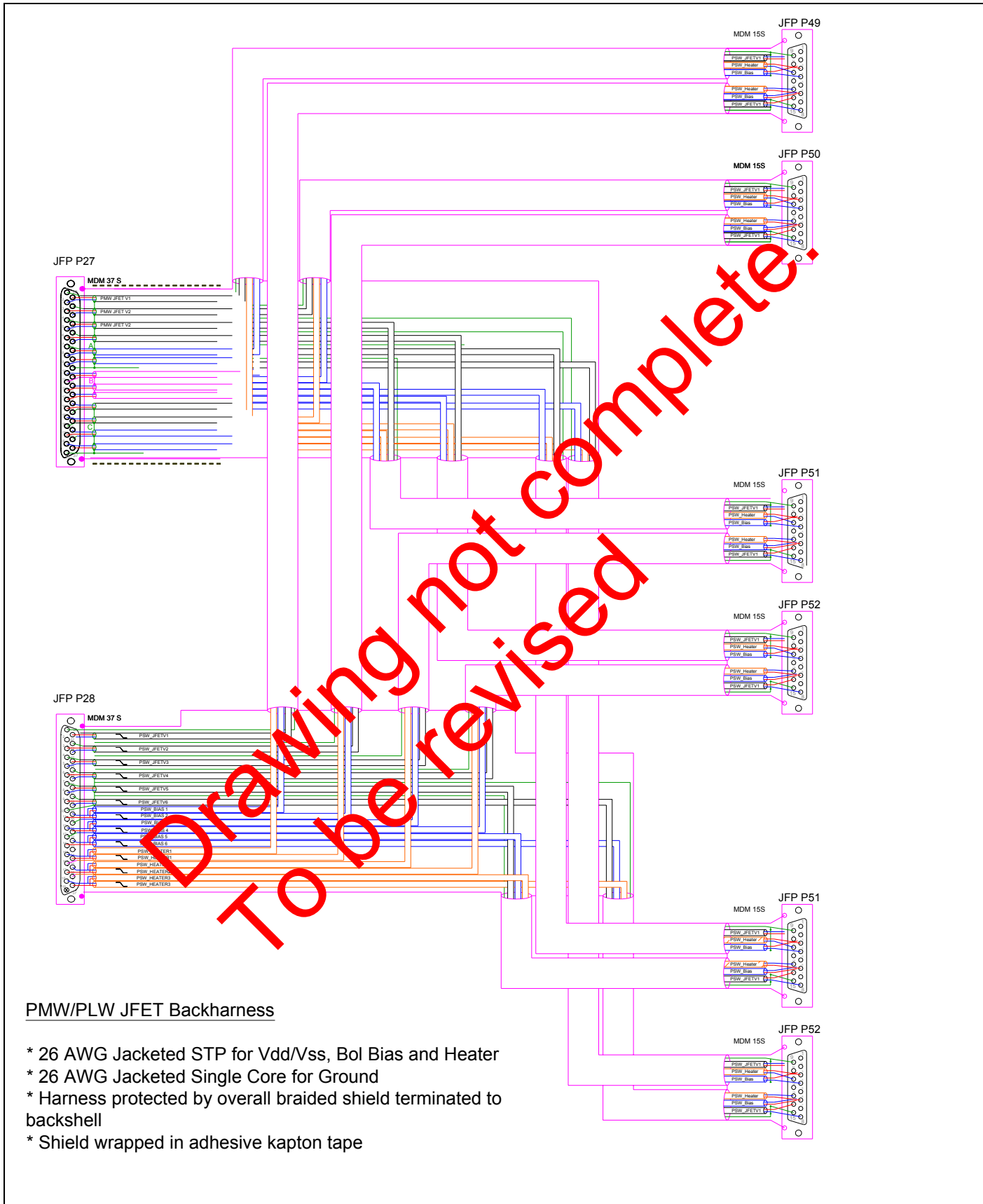

PMW/PLW JFET Backharness

- * 26 AWG Jacketed STP for Vdd/Vss, Bol Bias and Heater
- * 26 AWG Jacketed Single Core for Ground
- * Harness protected by overall braided shield terminated to backshell
- * Shield wrapped in adhesive kapton tape



SPIRE HARNESS DEFINITION DOCUMENT

Doc: SPIRE-RAL-PRJ-000608
Issue: 1.2
Date: 17/02/05
Page 216 of 245

Contact Details

Name	HSJFP		PMW/PLW Backplane Harness					
	JFP J27 MDM 37	JFP J28 MDM 37	HSJFP BP2					
			JFP J47 15way PLW	JFP J48 15way PLW	JFP J49 15way PMW	JFP J50 15way PMW	JFP J51 15way PMW	JFP J52 15way PMW
PMW_JFETV1_A +	20				10			
PMW_JFETV1_A -	2				1			
PMW_JFETV1_A shld	1				9(B)			
PMW_JFETV2_A +	3					10		
PMW_JFETV2_A -	22					1		
PMW_JFETV2_A shld	21					9(B)		
PMW_JFETV3_A +	23						10	
PMW_JFETV3_A -	5						1	
PMW_JFETV3_A shld	4						9(B)	
PMW_JFETV4_A +	6							10
PMW_JFETV4_A -	25							1
PMW_JFETV4_A shld	24							9(B)
PMW_BIAS1/2_A +	26				2	2		
PMW_BIAS1/2_A -	8				4	4		
PMW_BIAS1/2_A shld	7							
PMW_BIAS3/4_A +	27						2	2
PMW_BIAS3/4_A -	9						4	4
PMW_BIAS3/4_A shld	28							
PMW_GND WIRE_A	28							
PMW_HEATER A1 +	29				3	3		
PMW_HEATER A1 -	10				11	11		
PMW_HEATER A1 shld	11							
PMW_HEATER A2 +	12						3	3
PMW_HEATER A2 -	30						11	11
PMW_HEATER A2 shld	11							
PLW_HEATER A +	13		3	3				
PLW_HEATER A -	31		11	11				
PLW_HEATER A shld	11							
PLW_JFETV1_A +	14		10					
PLW_JFETV1_A -	32		1					
PLW_JFETV1_A shld	33							
PLW_JFETV2_A +	34			10				
PLW_JFETV2_A -	15			1				
PLW_JFETV2_A shld	16							
PLW_BIAS1_A +	17		2					
PLW_BIAS1_A -	35		4					
PLW_BIAS1_A shld	36							
PLW_BIAS2_A +	37			2				
PLW_BIAS2_A -	18			4				
PLW_BIAS2_A shld	19							
PLW_GROUND WIRE A	19							
PMW_JFETV1_B +		20			14			
PMW_JFETV1_B -		2			8			
PMW_JFETV1_B shld		1			15(B')			
PMW_JFETV2_B +		3				14		
PMW_JFETV2_B -		22				8		
PMW_JFETV2_B shld		21				15(B')		
PMW_JFETV3_B +		23					14	
PMW_JFETV3_B -		5					8	



SPIRE HARNESS DEFINITION DOCUMENT

Doc: SPIRE-RAL-PRJ-000608
Issue: 1.2
Date: 17/02/05
Page 217 of 245

Name	HSJFP		PMW/PLW Backplane Harness					
	JFP J27 MDM 37	JFP J28 MDM 37	HSJFP BP2					
			JFP J47 15way PLW	JFP J48 15way PLW	JFP J49 15way PMW	JFP J50 15way PMW	JFP J51 15way PMW	JFP J52 15way PMW
PMW_JFETV3_B shld		4					15(B')	
PMW_JFETV4_B +		6						14
PMW_JFETV4_B -		25						8
PMW_JFETV4_B shld		24						15(B')
PMW_BIAS1/2_B +		26			7	7		
PMW_BIAS1/2_B -		8			5	5		
PMW_BIAS1/2_B shld		7	B'					
PMW_BIAS3/4_B +		27					7	7
PMW_BIAS3/4_B -		9					5	5
PMW_BIAS3/4_B shld		28	B'					
PMW_GND WIRE_B		28	B'					
PMW_HEATER B1 +		29			6	6		
PMW_HEATER B1 -		10			13	13		
PMW_HEATER B1 shld		11	No Connection					
PMW_HEATER B2 +		12					6	6
PMW_HEATER B2 -		30					13	13
PMW_HEATER B2 shld		11	No Connection					
PLW_HEATER B +		13	6	6				
PLW_HEATER B -		31	13	13				
PLW_HEATER B shld		11	No Connection					
PLW_JFETV1_B +		14	14					
PLW_JFETV1_B -		32	8					
PLW_JFETV1_B shld		33	C'					
PLW_JFETV2_B +		34		14				
PLW_JFETV2_B -		15		8				
PLW_JFETV2_B shld		16	C'					
PLW_BIAS1_B +		17	7					
PLW_BIAS1_B -		35	5					
PLW_BIAS1_B shld		36	15 (C')					
PLW_BIAS2_B +		37		7				
PLW_BIAS2_B -		18		5				
PLW_BIAS2_B shld		19	C'					
PLW_GROUND WIRE B		19	C' (15)					

Note B: Commoned with HSJFP J 27 pins 1, 21, 4, 24, 7, 28

Note C: Commoned with HSJFP J 27 pins 33, 16, 36, 19

Note B': Commoned with HSJFP J 28 pins 1, 21, 4, 24, 7, 28

Note C': Commoned with HSJFP J 28 pins 33, 16, 36, 19

4.6.3 BS-Spectrometer

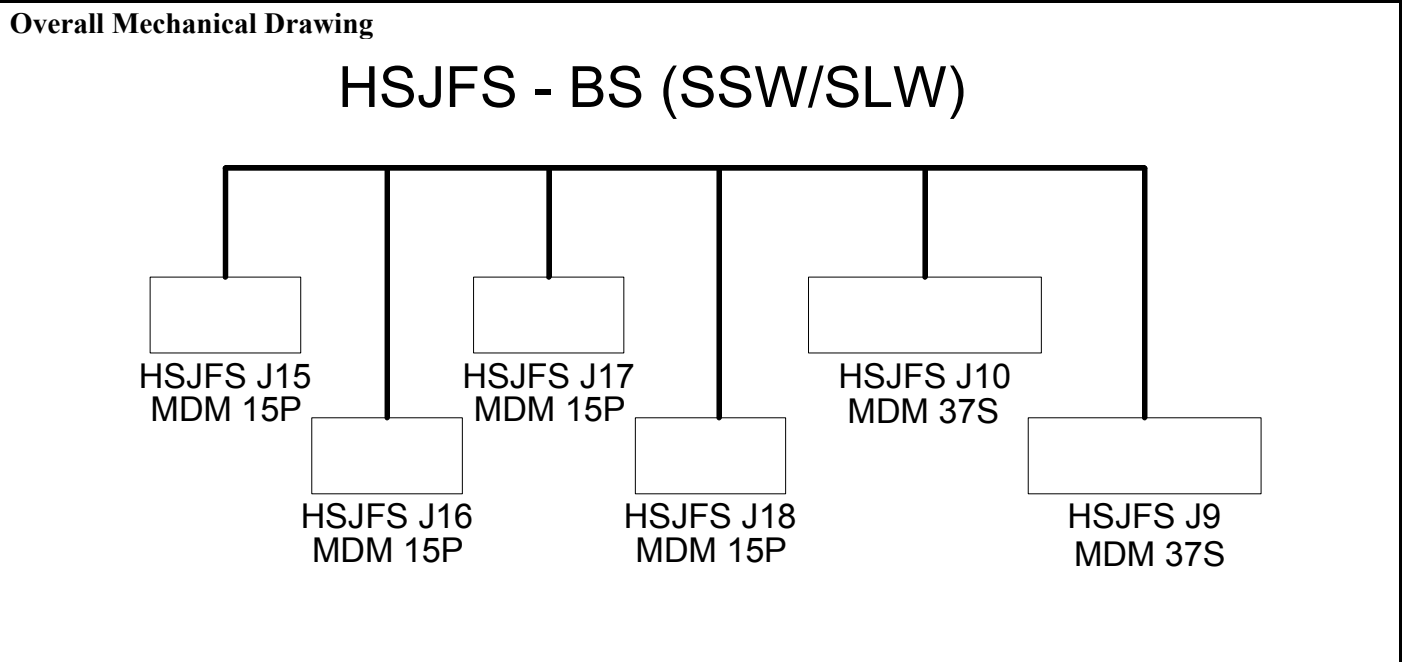

Connector/Backshell Details

JPL to specify.

Harness Layup

The BS harness is all at one temperature. Crimped 28AWG copper MDM

Pairs of wires should at least be twisted, and some inter-function screens may be appropriate, JPL to specify.

The whole harness must be very well RF screened to all its backshells.



SPIRE HARNESS DEFINITION DOCUMENT

Doc: SPIRE-RAL-PRJ-000608

Issue: 1.2

Date: 17/02/05

Page 219 of 245

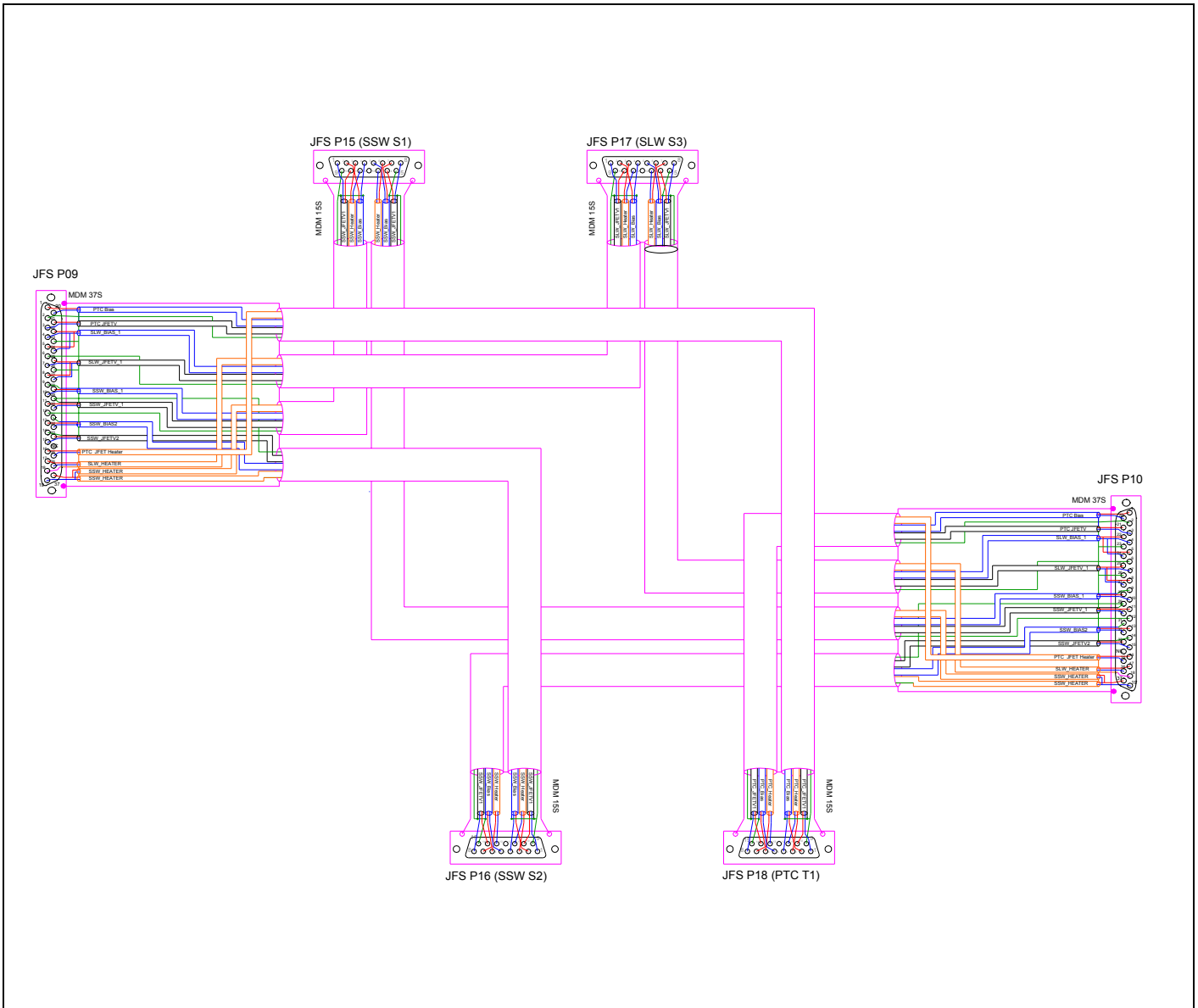



SPIRE HARNESS DEFINITION DOCUMENT

Doc: SPIRE-RAL-PRJ-000608
Issue: 1.2
Date: 17/02/05
Page 220 of 245

Contact Details

Function	HSJFS		HSJFS SSW/SLW Backplane Harness			
	HSJFS J9	HSJFS J10	HSJFS 15	HSJFS 16	HSJFS 17	HSJFS 18
	MDM 37	MDM 37	MDM 15	MDM 15	MDM 15	MDM 15
			SSW	SSW	SLW	PTC
PTC Bias_A +ve	1					2
PTC Bias_A -ve	20					4
PTC Bias_A Shield	NC		No Connection			
PTC Ground A	2					9
PTC JFETV Bias_A +ve	21					10
PTC JFETV Bias_A -ve	3					1
PTC JFETV Bias_A Shield	NC		No Connection			
SLW_BIAS_A1+ve	22				2 (C)	
SLW_BIAS_A1-ve	4				4 (B)	
SLW_BIAS_A1 shld	NC		No Connection			
SLW_BIAS_A2 +ve	5		C (Joined to JFS J9 Pin 22)			
SLW_BIAS_A2 -ve	24		B (Joined to JFS J9 Pin 4)			
SLW_BIAS_A2 shld	23		A (Joined to JFS J9 Pins 6, 26)			
SLW Ground A	6				9 (A)	
SLW_JFETV_A1 +ve	25				10 (E)	
SLW_JFETV_A1 -ve	7				1 (D)	
SLW_JFETV_A1 shld	NC		No Connection			
SLW_JFETV_A2 +ve	8		E (Joined to JFS J9 Pin 25)			
SLW_JFETV_A2 -ve	27		D (Joined to JFS J9 Pin 7)			
SLW_JFETV_A2 shld	6		A (Joined to JFS J9 Pins 6, 23)			
SSW_BIAS1_A +ve	28			2		
SSW_BIAS1_A -ve	10			4		
SSW_BIAS1_A shld	9		F (Joined to JFS J9 29,12, 31, 14)			
SSW_JFETV1_A +ve	11			10		
SSW_JFETV1_A -ve	30			1		
SSW_JFETV1_A shld	29			9 (F)		
SSW Ground A	12		9 (F)			
SSW_BIAS2_A +ve	13		2			
SSW_BIAS2_A -ve	32		4			
SSW_BIAS2_A shld	31		F (Joined to JFS J9 9, 29, 12, 14)			
SSW_JFETV2_A +ve	33		10			
SSW_JFETV2_A -ve	15		1			
SSW_JFETV2_A shld	14		F (Joined to JFS J9 9, 29, 12, 31)			
PTC JFET_HTR_A +ve	16					3
PTC JFET_HTR_A -ve	35					11
PTC JFET_HTR_A shld	NC		No Connection			
SLW_JFET_HEATER_A +ve	17				3	
SLW_JFET_HEATER_A -ve	36				11	
SLW_JFET_HEATER_A shld	18		No Connection			
SSW_JFET_HEATER_A +ve	37		3	3		
SSW_JFET_HEATER_A -ve	19		11	11		
SSW_JFET_HEATER_A shld	NC		No Connection			
PTC Bias_B +ve		1				7
PTC Bias_B -ve		20				5
PTC Bias_B Shield		2	No Connection			
PTC JFETV Bias_B +ve		21				15
PTC JFETV Bias_B -ve		3				14
PTC JFETV Bias_B Shield		2				8
PTC Ground B			No Connection			
SLW_BIAS_B1+ve		22			7 (C')	



SPIRE HARNESS DEFINITION DOCUMENT

Doc: SPIRE-RAL-PRJ-000608

Issue: 1.2

Date: 17/02/05

Page 221 of 245

Function	HSJFS		HSJFS SSW/SLW Backplane Harness			
	HSJFS J9	HSJFS J10	HSJFS 15	HSJFS 16	HSJFS 17	HSJFS 18
	MDM 37	MDM 37	MDM 15	MDM 15	MDM 15	MDM 15
			SSW	SSW	SLW	PTC
SLW_BIAS_B1-ve		4			5 (B')	
SLW_BIAS_B1 shld		6	No Connection			
SLW_BIAS_B2 +ve		5	C' (Joined to JFS J10 Pin 22)			
SLW_BIAS_B2 -ve		24	B' (Joined to JFS J10 Pin 4)			
SLW_BIAS_B2 shld		23	A' (Joined to JFS J10 Pins 6, 26)			
SLW Ground B		6			15 (A')	
SLW_JFETV_B1 +ve		25			14 (E')	
SLW_JFETV_B1 -ve		7			8 (D')	
SLW_JFETV_B1 shld		6	No Connection			
SLW_JFETV_B2 +ve		8	E' (Joined to JFS J10 Pin 25)			
SLW_JFETV_B2 -ve		27	D' (Joined to JFS J10 Pin 7)			
SLW_JFETV_B2 shld		6	A' (Joined to JFS J10 Pins 6, 23)			
SSW_BIAS1_B +ve		28		7		
SSW_BIAS1_B -ve		10		5		
SSW_BIAS1_B shld		9	F' (Joined to JFS J10 29,12, 31, 14)			
SSW_JFETV1_B +ve		11		14		
SSW_JFETV1_B -ve		30		8		
SSW_JFETV1_B shld		29		15 (F')		
SSW Ground B		12	15 (F')			
SSW_BIAS2_B +ve		13	7			
SSW_BIAS2_B -ve		32	5			
SSW_BIAS2_B shld		31	F' (Joined to JFS J10 9, 29, 12, 14)			
SSW_JFETV2_B +ve		33	14			
SSW_JFETV2_B -ve		15	8			
SSW_JFETV2_B shld		14	F' (Joined to JFS J10 9, 29, 12, 31)			
SLW_HEATER_B +ve		17				6
SLW_HEATER_B -ve		36				13
SLW_HEATER_B shld		18	No Connection			
SSW_HEATER_B +ve		37			6	
SSW_HEATER_B -ve		19			13	
SSW_HEATER_B shld		NC	No Connection			
PTC JFET_HTR_B +ve		16	6	6		
PTC JFET_HTR_B -ve		35	13	13		
PTC JFET_HTR_B shld		NC	No Connection			



SPIRE HARNESS DEFINITION DOCUMENT

Doc: SPIRE-RAL-PRJ-000608

Issue: 1.2

Date: 17/02/05

Page 222 of 245

4.7 Test Harnesses

4.7.1 T1 1553 Bus A

Overall Mechanical Drawing

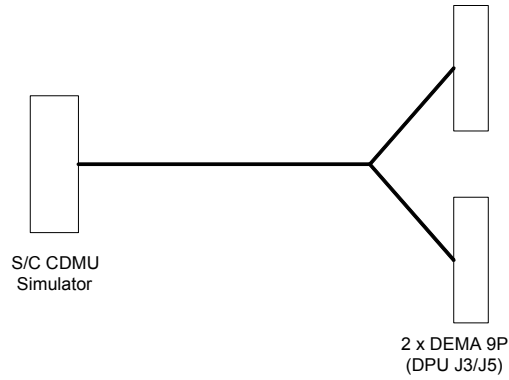

Connector/Backshell Details

DEMA 9 P + Glenair 550 - T - 039 - M - 1 - TBD - H - 0 - TBD to DPUJ3
 DEMA 9 P + Glenair 550 - T - 039 - M - 1 - TBD - H - 0 - TBD to DPUJ5

Harness Layup

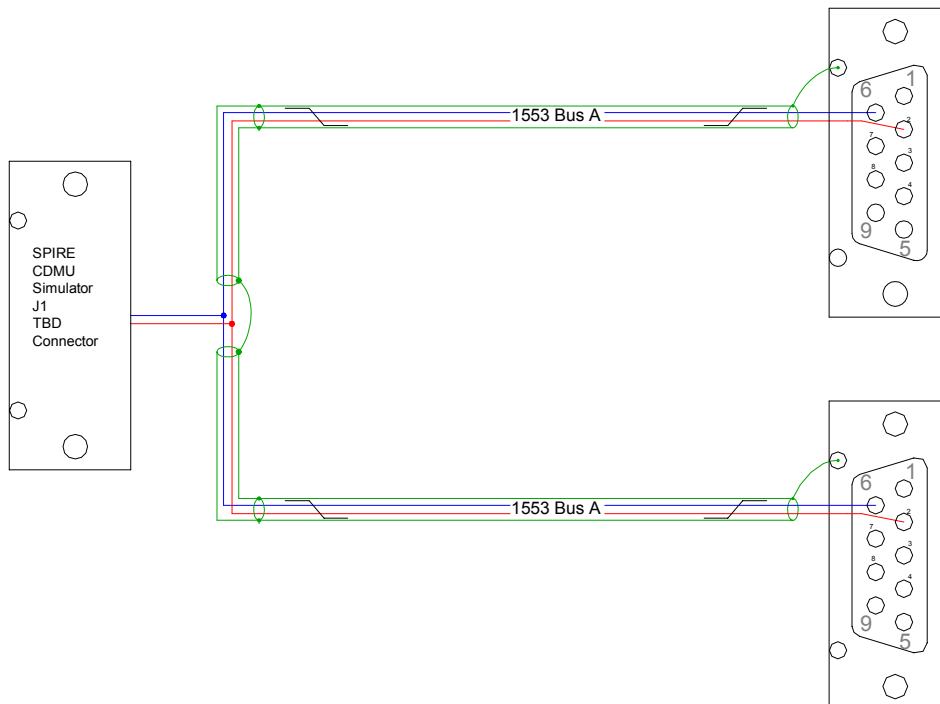



SPIRE HARNESS DEFINITION DOCUMENT

Doc: SPIRE-RAL-PRJ-000608
Issue: 1.2
Date: 17/02/05
Page 223 of 245

4.7.2 T2 1553 Bus B

Overall Mechanical Drawing

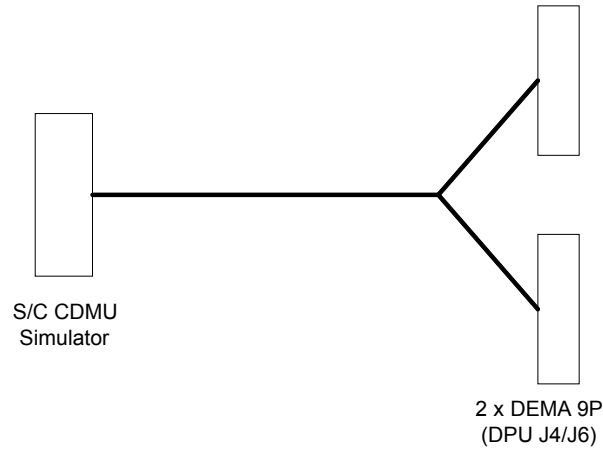

Connector/Backshell Details

DEMA 9 P + Glenair 550 - T - 039 - M - 1 - TBD - H - 0 - TBD to DPUJ4
DEMA 9 P + Glenair 550 - T - 039 - M - 1 - TBD - H - 0 - TBD to DPUJ6

Harness Layup

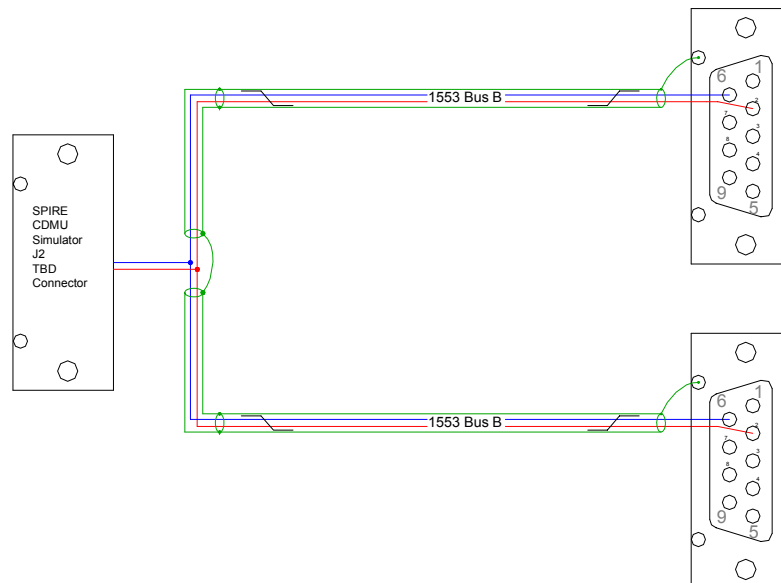



SPIRE HARNESS DEFINITION DOCUMENT

Doc: SPIRE-RAL-PRJ-000608
Issue: 1.2
Date: 17/02/05
Page 224 of 245

4.7.3 T3 DPU-P Power

Overall Mechanical Drawing

Connector/Backshell Details
To HSDPU J1

Harness Layup

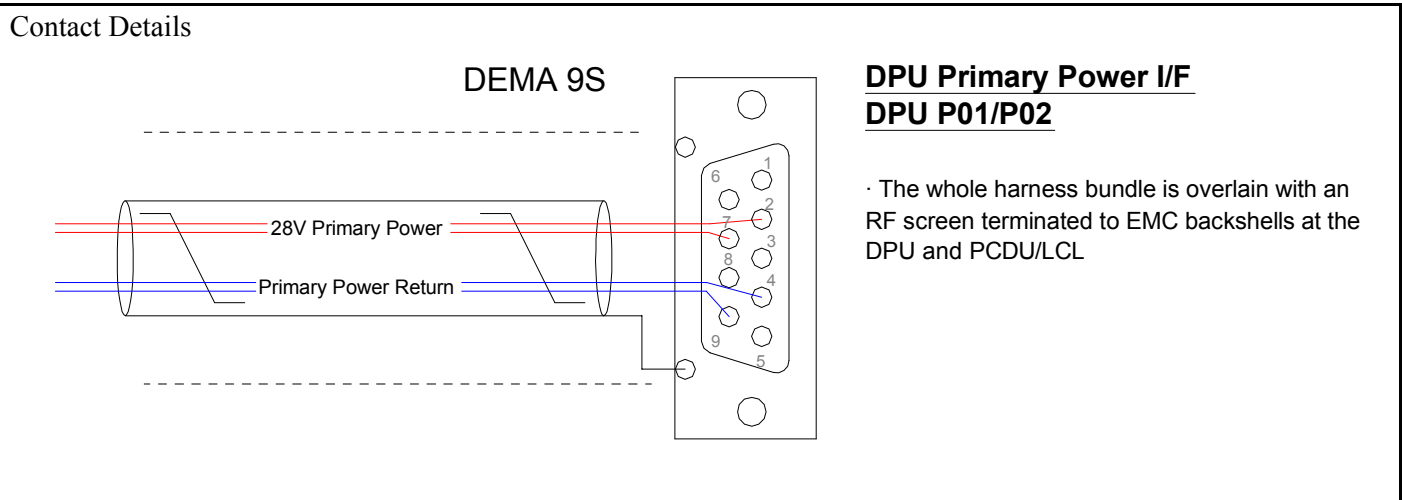

4.7.4 T4 DPU-R Power

Overall Mechanical Drawing

Connector/Backshell Details
To HSDPU J2

Harness Layup

Contact Details
As per §4.7.3 T3 DPU-P Power

4.7.5 T5 FCU-P Power

Overall Mechanical Drawing

1:1

Connector/Backshell Details

To HSFCU J5

Harness Layup

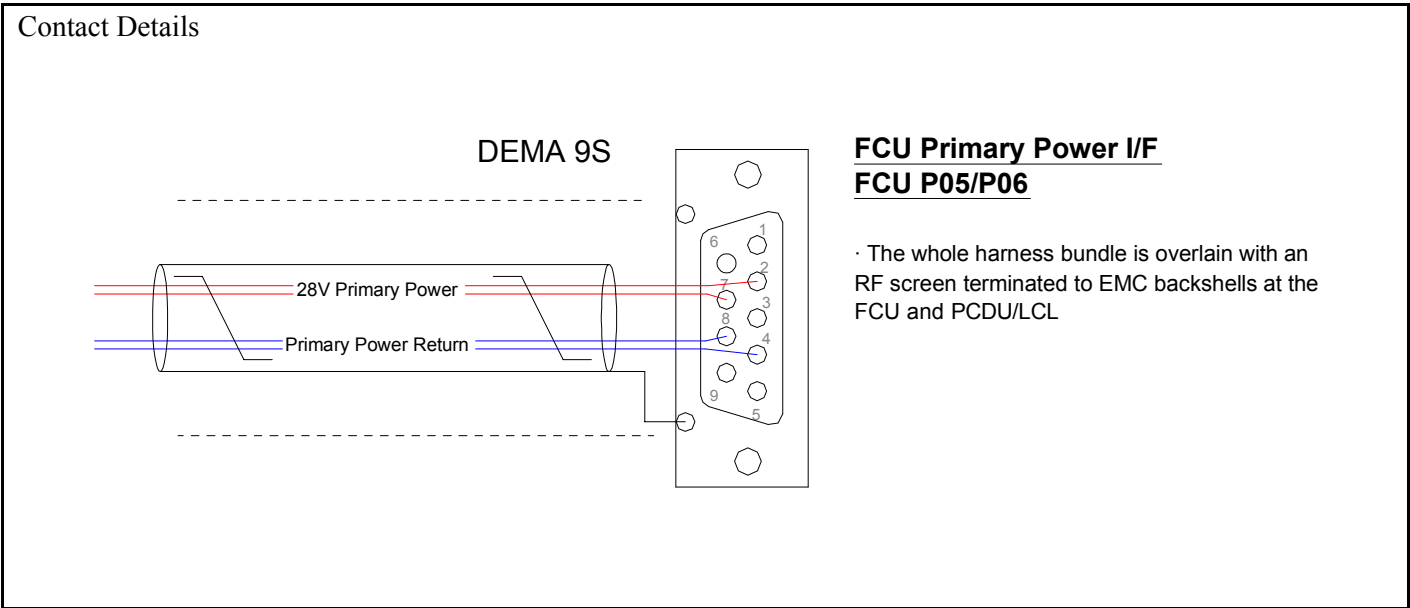

4.7.6 T6 FCU-R Power

Overall Mechanical Drawing

1:1

Connector/Backshell Details

To HSFCU J6

Harness Layup

Contact Details

As per §4.7.5 - T5 FCU-P Power

4.7.7 T7 Mechanisms Launch Lock Confirm (Prime)

4.7.8 T8 Mechanisms Launch Lock Confirm (Redundant)



SPIRE HARNESS DEFINITION DOCUMENT

Doc: SPIRE-RAL-PRJ-000608

Issue: 1.2

Date: 17/02/05

Page 228 of 245

4.8 STM Thermometry Harnesses

4.8.1 External STM

Mechanical Drawing

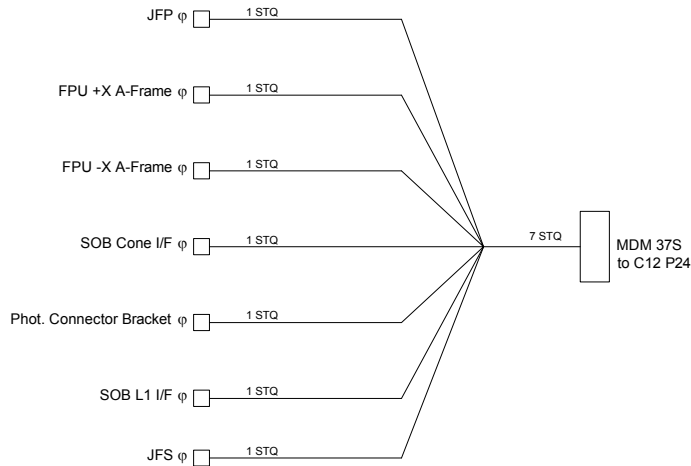

Connector Backshell Details

Potted shielded

Harness Layup

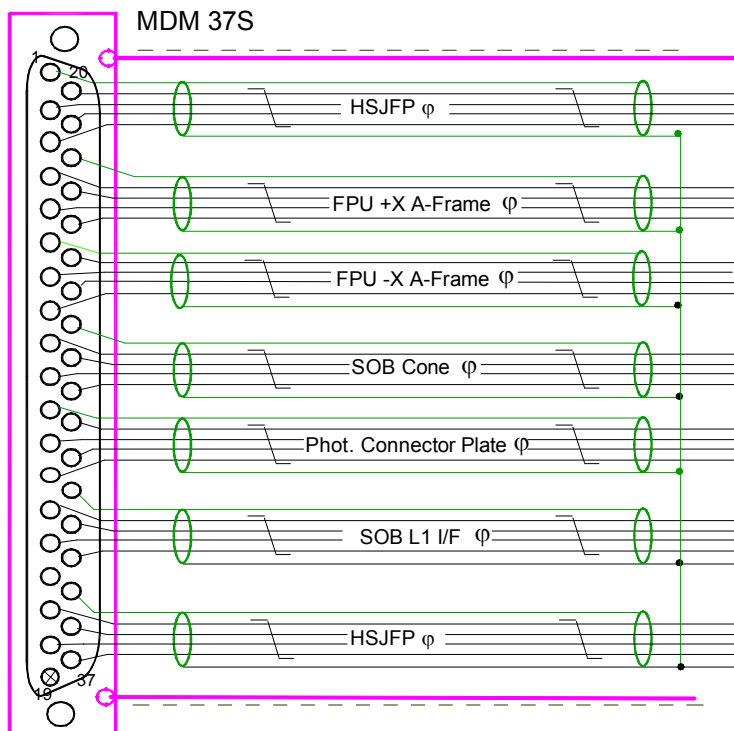

External STM Thermometry

- 7 Insulated STQs - 38 AWG SS Conductors
- Mates with C12 - P24
- The dotted lines indicate insulation jacket covering the overshield. Only required at clamp points but could cover entire length of harness.
- The connector is an MDM37S - As viewed from the exposed contacts (mating surface)
- STQ has four colours, viz. Black Red Blue White



SPIRE HARNESS DEFINITION DOCUMENT

Doc: SPIRE-RAL-PRJ-000608
Issue: 1.2
Date: 17/02/05
Page 229 of 245

Connector Details

Sensor	Function	37way P23	Wire
HSJFP Temp.	I+ Red	20	Insulated screened twisted quad
	V+ White	2	
	V- Blue	3	
	I- Black	21	
	Shield	1	
FPU +X A-Frame Temp.	I+ Red	4	Insulated screened twisted quad
	V+ White	23	
	V- Blue	24	
	I- Black	5	
	Shield	22	
FPU -X A-Frame Temp.	I+ Red	25	Insulated screened twisted quad
	V+ White	7	
	V- Blue	8	
	I- Black	26	
	Shield	6	
SOB Cone Temp.	I+ Red	9	Insulated screened twisted quad
	V+ White	28	
	V- Blue	29	
	I- Black	10	
	Shield	27	
Photometer Connector Plate Temp.	I+ Red	30	Insulated screened twisted quad
	V+ White	12	
	V- Blue	13	
	I- Black	31	
	Shield	11	
SOB L1 I/F Temp.	I+ Red	14	Insulated screened twisted quad
	V+ White	33	
	V- Blue	34	
	I- Black	15	
	Shield	32	
HSJFS Temp.	I+ Red	17	Insulated screened twisted quad
	V+ White	18	
	V- Blue	36	
	I- Black	37	
	Shield	35	



SPIRE HARNESS DEFINITION DOCUMENT

Doc: SPIRE-RAL-PRJ-000608

Issue: 1.2

Date: 17/02/05

Page 230 of 245

Harness lengths

Thermistor	Copper length	Stainless Steel Length
JFP	1800mm	150mm
FPU +Y A-Frame	650mm	150mm
FPU -Y A-Frame	1400mm	150mm
SOB Cone I/F	550mm	150mm
Photometer Connector Bracket	1800mm	250mm
SOB L1 I/F	1020mm	200mm
JFS	600mm	150mm



SPIRE HARNESS DEFINITION DOCUMENT

Doc: SPIRE-RAL-PRJ-000608
Issue: 1.2
Date: 17/02/05
Page 231 of 245

4.8.2 Internal STM

Mechanical Drawing

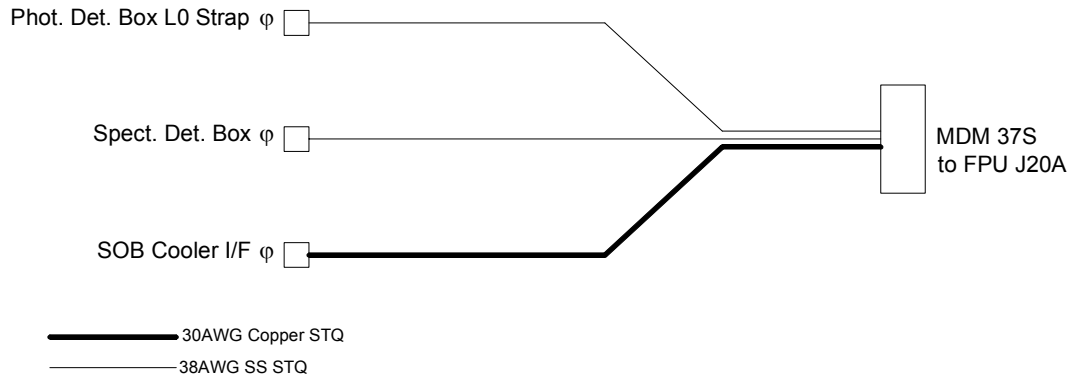

Connector Backshell Details

Potted shielded

Harness Layup

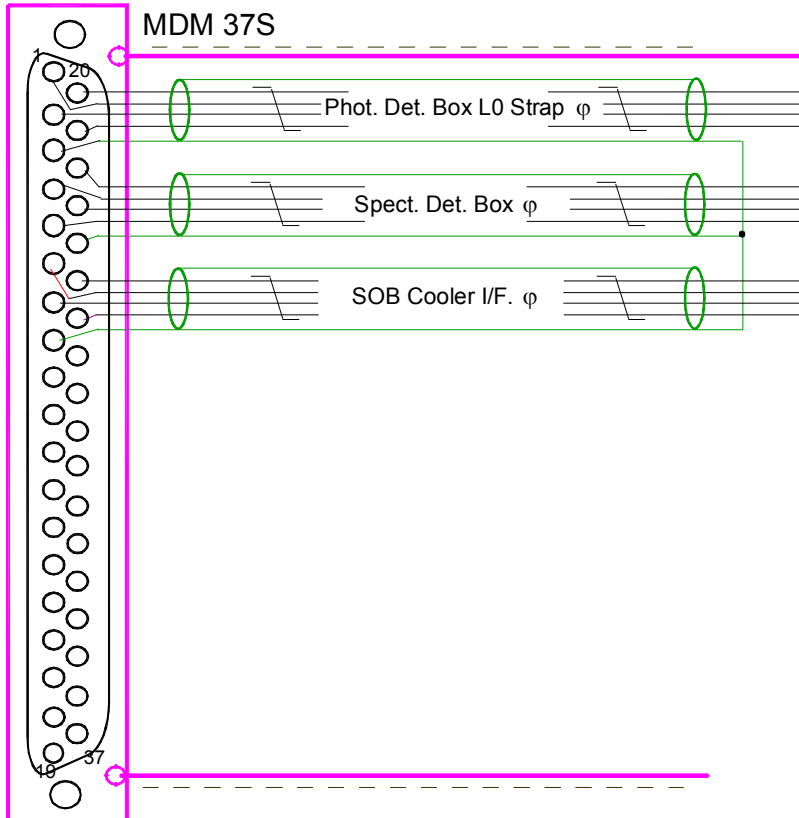

Internal STM Thermometry

- 3 Insulated STQs
 - Phot and Spect Det. Box 38 AWG SS Conductors
 - SOB Cooler I/F 30 AWG Copper Conductors
- Mates with RF Filter J20A
- The dotted lines indicate insulation jacket covering the overshield. Only required at clamp points but could cover entire length of harness.
- The connector is an MDM37S - As viewed from the exposed contacts (mating surface)
- STQ has four colours, viz. Black Red Blue White



SPIRE HARNESS DEFINITION DOCUMENT

Doc: SPIRE-RAL-PRJ-000608
Issue: 1.2
Date: 17/02/05
Page 232 of 245

Connector Details

Sensor	Function	37way	Wire
Phot. Det. Box L0 Strap Temp.	I+ Red	20	Insulated screened twisted quad
	V+ White	1	
	V- Blue	2	
	I- Black	21	
	Shield	3	
Spect. Det. Box Temp.	I+ Red	22	Insulated screened twisted quad
	V+ White	4	
	V- Blue	5	
	I- Black	23	
	Shield	24	
SOB Cooler I/F Temp.	I+ Red	25	Insulated screened twisted quad
	V+ White	6	
	V- Blue	7	
	I- Black	26	
	Shield	8	

4.8.3 CQM/STM Level-0 Strap Harness

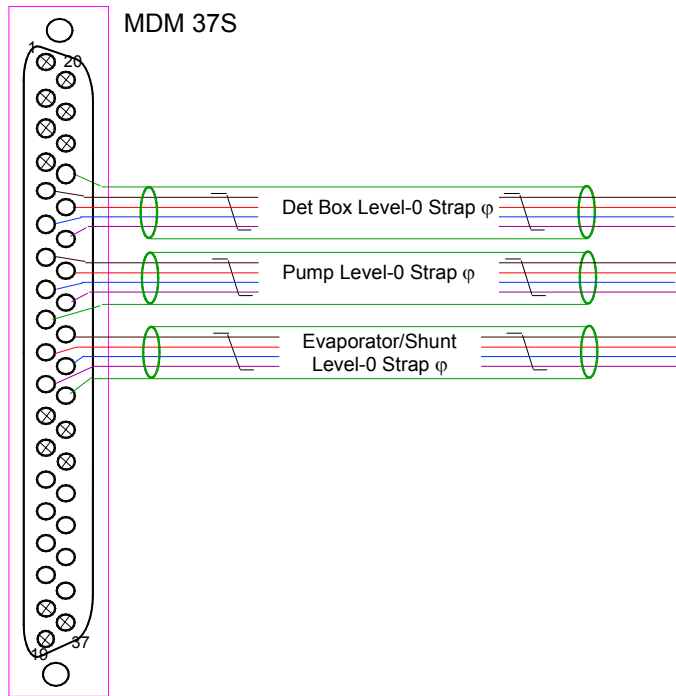

CQM/STM Level-0 Strap Harness

- 3 Insulated STQs
- Harness connector is a **Socket**. Drawing indicates pin allocation as seen from the front, engaging face of the connector.
- No overshield over individual tails

Connector Details				
Sensor	Function	37way	Wire	Sensor
Det Box Level-0 Strap	I+ Red (Black on Cernox sensor)	5	Insulated screened twisted quad	X24462
	V+ White (Clear on Cernox sensor)	6		
	V- Blue (Green on Cernox sensor)	24		
	I- Black (Red on Cernox sensor)	25		
	Shield (unterminated at sensor)	23		
Pump Level-0 Strap	I+ Red (Black on Cernox sensor)	7	Insulated screened twisted quad	X24411
	V+ White (Clear on Cernox sensor)	8		
	V- Blue (Green on Cernox sensor)	26		
	I- Black (Red on Cernox sensor)	27		
	Shield (unterminated at sensor)	9		
Evaporator Level-0 Strap	I+ Red (Black on Cernox sensor)	10	Insulated screened twisted quad	X24465
	V+ White (Clear on Cernox sensor)	11		
	V- Blue (Green on Cernox sensor)	28		
	I- Black (Red on Cernox sensor)	29		
	Shield (unterminated at sensor)	30		

Notes:

- No over shield on individual tails.
- Wires: Stainless Steel/Manganin AWG38/40
- Length: 1250mm approx
- No EMC backshell required.

Sensors terminated with strain relief on fine cryogenic wires provided by heat shrink



SPIRE HARNESS DEFINITION DOCUMENT

Doc: SPIRE-RAL-PRJ-000608
 Issue: 1.2
 Date: 17/02/05
 Page 234 of 245

4.8.4 CQM Cryovibration Thermometry Harness

Mechanical Drawing

See Harness layup

Connector Backshell Details

MDM 37P to DCMA 37P
 Potted, Stycast 2850FT, non-RF backshells

Harness Layup

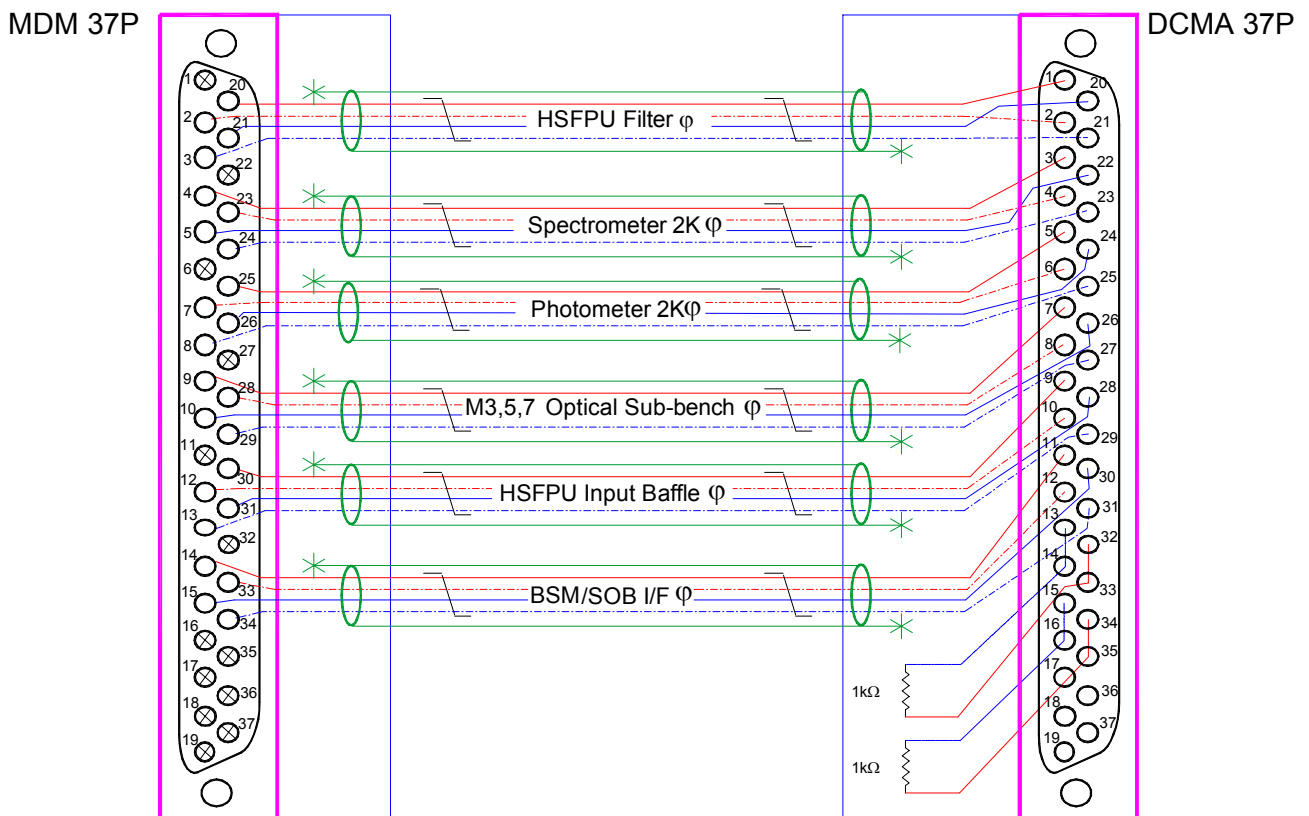

Length = 2000mm
 Six 30AWG Stainless Steel STQ



SPIRE HARNESS DEFINITION DOCUMENT

Doc: SPIRE-RAL-PRJ-000608
Issue: 1.2
Date: 17/02/05
Page 235 of 245

Function	37way MDM	Wire lay-up	37way DCMA
FPU Filter temperature I+	20	Insulated screened twisted quad	1
FPU Filter temperature V+	2		2
FPU Filter temperature V-	3		21
FPU Filter temperature I-	21		20
FPU Filter temperature shld	NC		NC
Spectrometer Det. Box temperature I+	4	Insulated screened twisted quad	3
Spectrometer Det. Box temperature V+	23		4
Spectrometer Det. Box temperature V-	24		23
Spectrometer Det. Box temperature I-	5		22
Spectrometer Det. Box temperature shld	NC		NC
Photometer Det. Box temperature I+	25	Insulated screened twisted quad	5
Photometer Det. Box temperature V+	7		6
Photometer Det. Box temperature V-	8		25
Photometer Det. Box temperature I-	26		24
Photometer Det. Box temperature shld	NC		NC
Optical Subench temperature I+	9	Insulated screened twisted quad	7
Optical Subench temperature V+	28		8
Optical Subench temperature V-	29		27
Optical Subench temperature I-	10		26
Optical Subench temperature shld	NC		NC
HSFPU Input Baffle temperature I+	30	Insulated screened twisted quad	9
HSFPU Input Baffle temperature V+	12		10
HSFPU Input Baffle temperature V-	13		29
HSFPU Input Baffle temperature I-	31		28
HSFPU Input Baffle temperature shld	NC		NC
BSM/SOB I/F temperature I+	14	Insulated screened twisted quad	11
BSM/SOB I/F temperature V+	33		12
BSM/SOB I/F temperature V-	34		31
BSM/SOB I/F temperature I-	15		30
BSM/SOB I/F temperature shld	NC		NC
1kΩ Resistor +	NC	Insulated screened twisted quad	13
	NC		14
1kΩ Resistor -	NC		33
	NC		32
1kΩ Resistor +	NC	Insulated screened twisted quad	15
	NC		16
1kΩ Resistor -	NC		35
	NC		34



SPIRE HARNESS DEFINITION DOCUMENT

Doc: SPIRE-RAL-PRJ-000608
Issue: 1.2
Date: 17/02/05
Page 236 of 245

ANNEX 1 – Internal Cryostat Wiring List

Notes:

- The column headed "Implementation" is intended to indicate the screening configuration around functions necessary for the SPIRE instrument. The terms used are as if each function were implemented as a single conductor (STP="Screened Twisted Pair") but this is not a requirement on the number of conductors used for the actual physical construction. Thus, individual functions can in principle be multiple wires if the harness fabricator so requires.
- 12-ax is a particular implementation as shown in Annex 4
- The resistance value for each individual function is to be considered as the starting point for the design and can be optimised by negotiation on a case-by-case basis.
- The resistance values are assumed to be the values applicable to normal operation in flight.
- A harness overshield is employed as described in §4.2, 4.3 and 4.4.

Name	128 Way Connector	FPU/JFS/JFP Connector Label	Unit Connector Type	Harness Connector Label	Harness Connector Type	Description	Number of Conductors excl. shields	Number of Inner Shields	Implementation	Max. Impedance Requirements			Max. Current per Conductor	Average Current (see note 9)	Operating Mode			Max. Volts	Duty Cycle			Peak Dissipation	Average Dissipation
										R (W)	C(pF)	L(uH)			P	Sp	CR		t	T	(t x T)		
C1 Type 3	CW 1	HSJFS J5	MDM 25 P	HSJFS P5	MDM 25 S	Bolometer signals from JFS (SLW 1-12)	24	6	DS 12-ax	500	1000pF	0.08uH	1.0E-09	5.0E-10	0	1	0	0.1	50%	33%	17%	1.20E-14	5.00E-16
						Anti-cross talk ground wires	12	NA		500	1000pF	0.08uH	0.0E+00	0.0E+00	0	0	0	0.1	50%	0%	0%	0.00E+00	0.00E+00
						Bolometer signals from JFS (SLW 13-24)	24	6	DS 12-ax	500	1000pF	0.08uH	1.0E-09	5.0E-10	0	1	0	0.1	50%	33%	17%	1.20E-14	5.00E-16
						Anti-cross talk ground wires	12	NA		500	1000pF	0.08uH	0.0E+00	0.0E+00	0	0	0	0.1	0%	0%	0%	0.00E+00	0.00E+00
						PTC Bias	2	2	DSTP	200	1000pF	0.08	3.2E-08	8.0E-09	1	0	0	10	50%	33%	17%	4.10E-13	4.27E-15
						PTC Ground wire	1	0	S	50	1000pF	0.08uH	0	0	0	0	0	10	50%	33%	17%	0.00E+00	0.00E+00
						PTC JFET Bias	2	2	DSTP	100	1000pF	0.08uH	5.0E-03	2.0E-04	1	0	0	10	50%	33%	17%	5.00E-03	1.33E-05
						SLW Bolometer Bias	4	4	DSTP	200	1000pF	0.08uH	9.6E-08	2.4E-08	0	1	0	10	50%	33%	17%	7.37E-12	7.68E-14
						SLW JFET Bias	4	4	DSTP	100	1000pF	0.08uH	2.5E-03	6.0E-04	0	1	0	10	50%	33%	17%	2.50E-03	2.40E-05
						SLW Ground wire	1	0	S	50	1000pF	0.08uH	0	0	0	0	0	10	50%	33%	17%	0.00E+00	0.00E+00
						SSW Bolometer Bias	4	4	DSTP	200	1000pF	0.08uH	1.2E-03	4.6E-08	0	1	0	10	50%	33%	17%	1.15E-03	3.07E-13
						SSW JFET Bias	4	4	DSTP	100	1000pF	0.08uH	5.0E-03	1.2E-03	0	1	0	10	50%	33%	17%	1.00E-02	9.60E-05
						SSW Ground Wire	1	0	S	50	1000pF	0.08uH	0	0	0	0	0	10	50%	33%	17%	0.00E+00	0.00E+00
						PTC JFET Heater	2	2	DSTP	200	1000pF	0.08uH	1.9E-03	4.6E-04	0	0	0	10	0.2%	33%	0%	1.48E-03	5.35E-08
						SLW JFET Heater	2	2	DSTP	200	1000pF	0.08uH	3.3E-03	8.3E-04	0	0	0	10	0.2%	33%	0%	4.44E-03	1.61E-07
						SSW JFET Heater	2	2	DSTP	200	1000pF	0.08uH	6.7E-03	1.7E-03	0	0	0	10	0.2%	33%	0%	1.78E-02	6.43E-07
						PTC Bias	2	2	DSTP	200	1000pF	0.08	3.2E-08	8.0E-09	0	0	0	10	50%	33%	17%	4.10E-13	4.27E-15
						PTC Ground wire	1	0	S	50	1000pF	0.08uH	0	0	0	0	0	10	50%	33%	17%	0.00E+00	0.00E+00
						PTC JFET Bias	2	2	DSTP	100	1000pF	0.08uH	5.0E-03	2.0E-04	0	0	0	10	50%	33%	17%	5.00E-03	1.33E-05
						SLW Bolometer Bias	4	4	DSTP	200	1000pF	0.08uH	9.6E-08	2.4E-08	0	0	0	10	50%	33%	17%	7.37E-12	7.68E-14
SLW JFET Bias	4	4	DSTP	100	1000pF	0.08uH	2.5E-03	6.0E-04	0	0	0	10	50%	33%	17%	2.50E-03	2.40E-05						
SLW Ground wire	1	0	S	50	1000pF	0.08uH	0	0	0	0	0	10	50%	33%	17%	0.00E+00	0.00E+00						
SSW Bolometer Bias	4	4	DSTP	200	1000pF	0.08uH	1.2E-03	4.6E-08	0	0	0	10	50%	33%	17%	1.15E-03	3.07E-13						
SSW JFET Bias	4	4	DSTP	100	1000pF	0.08uH	5.0E-03	1.2E-03	0	0	0	10	50%	33%	17%	1.00E-02	9.60E-05						
SSW Ground Wire	1	0	S	50	1000pF	0.08uH	0	0	0	0	0	10	50%	33%	17%	0.00E+00	0.00E+00						
PTC JFET Heater	2	2	DSTP	200	1000pF	0.08uH	1.9E-03	4.6E-04	0	0	0	10	0.2%	33%	0%	1.48E-03	5.35E-08						
SLW JFET Heater	2	2	DSTP	200	1000pF	0.08uH	3.3E-03	8.3E-04	0	0	0	10	0.2%	33%	0%	4.44E-03	1.61E-07						
SSW JFET Heater	2	2	DSTP	200	1000pF	0.08uH	6.7E-03	1.7E-03	0	0	0	10	0.2%	33%	0%	1.78E-02	6.43E-07						
C2 Type 4	CW 2	HSJFS J7	MDM 25 P	HSJFS P7	MDM 25S	Bolometer signals from JFS (300-mK TC 1-3)	8	2	DS 12-ax	500	1000pF	0.08uH	1.0E-09	5.0E-10	1	0	0	0.1	50%	33%	17%	4.00E-15	1.67E-16
						Anti-cross talk ground wires	4	NA		500	1000pF	0.08uH	0.0E+00	0.0E+00	0	0	0	0.1	50%	33%	17%	0.00E+00	0.00E+00
						Bolometer signals from JFS (SSW 1-12)	24	6	DS 12-ax	500	1000pF	0.08uH	1.0E-09	5.0E-10	0	1	0	0.1	50%	33%	17%	1.20E-14	5.00E-16
						Anti-cross talk ground wires	12	NA		500	1000pF	0.08uH	0.0E+00	0.0E+00	0	0	0	0.1	50%	33%	17%	0.00E+00	0.00E+00
						Bolometer signals from JFS (SSW 13-24)	24	6	DS 12-ax	500	1000pF	0.08uH	1.0E-09	5.0E-10	0	1	0	0.1	50%	33%	17%	1.20E-14	5.00E-16
						Anti-cross talk ground wires	12	NA		500	1000pF	0.08uH	0.0E+00	0.0E+00	0	0	0	0.1	50%	33%	17%	0.00E+00	0.00E+00
						Bolometer signals from JFS (SSW 25-36)	24	6	DS 12-ax	500	1000pF	0.08uH	1.0E-09	5.0E-10	0	1	0	0.1	50%	33%	17%	1.20E-14	5.00E-16
						Anti-cross talk ground wires	12	NA		500	1000pF	0.08uH	0.0E+00	0.0E+00	0	0	0	0.1	50%	33%	17%	0.00E+00	0.00E+00
HSJFS J4	MDM 25 P	HSJFS P4	MDM 25S	Bolometer signals from JFS (SSW 37-42)	16	4	DS 12-ax	500	1000pF	0.08uH	1.0E-09	5.0E-10	0	1	0	0.1	50%	33%	17%	8.00E-15	3.33E-16		
				Anti-cross talk ground wires	8	NA		500	1000pF	0.08uH	0.0E+00	0.0E+00	0	0	0	0.1	50%	33%	17%	0.00E+00	0.00E+00		



SPIRE HARNESS DEFINITION DOCUMENT

Doc: SPIRE-RAL-PRJ-000608
Issue: 1.2
Date: 17/02/05
Page 237 of 245

Name	128 Way Connector	FPU/JFS/JFP Connector Label	Unit Connector Type	Harness Connector Label	Harness Connector Type	Description	Number of Conductors excl. shields	Number of Inner Shields	Implementation	Max. Impedance Requirements			Max. Current per Conductor	Average Current (see note 9)	Operating Mode			Max. Volts	Duty Cycle			Peak Dissipation	Average Dissipation				
										R (W)	C (pF)	L (uH)			P	Sp	CR		t	T	(t x T)						
C3		HSJFP J25	MDM 37 S	JFP P25	MDM 37P	PSW JFET Bias	12	12	DSTP	100	1000pF	0.08uH	5.0E-03	1.2E-03	1	0	0	10	50%	33%	17%	3.00E-02	2.88E-04				
						PSW Ground	1	0	S	50	1000pF	0.08uH	0	0	0	0	10	50%	33%	17%	0.00E+00	0.00E+00					
						PSW Bolometer Bias	6	6	DSTP	200	1000pF	0.08uH	3.8E-07	9.6E-08	1	0	0	10	50%	33%	17%	1.77E-10	1.84E-12				
						PSW Heater	6	6	DSTP	200	1000pF	0.08uH	3.8E-03	9.6E-04	0	0	0	10	0.2%	33%	0%	1.78E-02	6.42E-07				
						PMW JFET Bias	8	8	DSTP	100	1000pF	0.08uH	5.0E-03	1.2E-03	1	0	0	10	50%	33%	17%	2.00E-02	1.92E-04				
						PMW Bolometer Bias	4	4	DSTP	200	1000pF	0.08uH	3.8E-07	9.6E-08	1	0	0	10	50%	33%	17%	1.18E-10	1.23E-12				
						PMW Ground	1	0	S	50	1000pF	0.08uH	0	0	0	0	0	10	50%	33%	17%	0.00E+00	0.00E+00				
						PMW JFET Heater	4	4	DSTP	200	1000pF	0.08uH	3.8E-03	9.6E-04	0	0	0	10	0.2%	33%	0%	1.18E-02	4.28E-07				
						PLW JFET Heater	2	2	DSTP	200	1000pF	0.08uH	3.8E-03	9.6E-04	0	0	0	10	0.2%	33%	0%	5.92E-03	2.14E-07				
						PLW JFET Bias	4	4	DSTP	100	1000pF	0.08uH	5.0E-03	1.2E-03	1	0	0	10	50%	33%	17%	1.00E-02	9.60E-05				
						PLW Bolometer Bias	4	4	DSTP	200	1000pF	0.08uH	1.9E-07	4.8E-08	1	0	0	10	50%	33%	17%	2.95E-11	3.07E-13				
						PLW Ground	1	0	S	50	1000pF	0.08uH	0	0	0	0	0	10	50%	33%	17%	0.00E+00	0.00E+00				
						HSJFP J26	MDM 37 S	JFP P26	MDM 37P	PSW JFET Bias	12	12	DSTP	100	1000pF	0.08uH	5.0E-03	1.2E-03	0	0	0	10	50%	33%	17%	3.00E-02	2.88E-04
										PSW Ground	1	0	S	50	1000pF	0.08uH	0	0.0E+00	0	0	0	10	50%	33%	17%	0.00E+00	0.00E+00
		PSW Bolometer Bias	6	6	DSTP					200	1000pF	0.08uH	3.8E-07	9.6E-08	0	0	0	10	50%	33%	17%	1.77E-10	1.84E-12				
		PSW Heater	6	6	DSTP					200	1000pF	0.08uH	3.8E-03	9.6E-04	0	0	0	10	0.2%	33%	0%	1.78E-02	6.42E-07				
		PMW JFET Bias	8	8	DSTP					100	1000pF	0.08uH	5.0E-03	1.2E-03	0	0	0	10	50%	33%	17%	2.00E-02	1.92E-04				
		PMW Bolometer Bias	4	4	DSTP					200	1000pF	0.08uH	3.8E-07	9.6E-08	0	0	0	10	50%	33%	17%	1.18E-10	1.23E-12				
		PMW Ground	1	0	S					50	1000pF	0.08uH	0.0E+00	0.0E+00	0	0	0	10	50%	33%	17%	0.00E+00	0.00E+00				
		PMW JFET Heater	4	4	DSTP					200	1000pF	0.08uH	3.8E-03	9.6E-04	0	0	0	10	0%	33%	0%	1.18E-02	4.28E-07				
		PLW JFET Heater	2	2	DSTP					200	1000pF	0.08uH	3.8E-03	9.6E-04	0	0	0	10	0%	33%	0%	5.92E-03	2.14E-07				
		PLW JFET Bias	4	4	DSTP					100	1000pF	0.08uH	5.0E-03	1.2E-03	0	0	0	10	50%	33%	17%	1.00E-02	9.60E-05				
		PLW Bolometer Bias	4	4	DSTP					200	1000pF	0.08uH	1.9E-07	4.8E-08	0	0	0	10	50%	33%	17%	2.95E-11	3.07E-13				
		PLW Ground	1	0	S					50	1000pF	0.08uH	0.0E+00	0.0E+00	0	0	0	10	50%	33%	17%	0.00E+00	0.00E+00				
		HSJFP J28	MDM 37 S	JFP P28	MDM 37P					PSW JFET Bias	12	12	DSTP	100	1000pF	0.08uH	5.0E-03	1.2E-03	0	0	0	10	50%	33%	17%	3.00E-02	2.88E-04
										PSW Ground	1	0	S	50	1000pF	0.08uH	0	0.0E+00	0	0	0	10	50%	33%	17%	0.00E+00	0.00E+00
						PSW Bolometer Bias	6	6	DSTP	200	1000pF	0.08uH	3.8E-07	9.6E-08	0	0	0	10	50%	33%	17%	1.77E-10	1.84E-12				
						PSW Heater	6	6	DSTP	200	1000pF	0.08uH	3.8E-03	9.6E-04	0	0	0	10	0.2%	33%	0%	1.78E-02	6.42E-07				
PMW JFET Bias	8					8	DSTP	100	1000pF	0.08uH	5.0E-03	1.2E-03	0	0	0	10	50%	33%	17%	2.00E-02	1.92E-04						
PMW Bolometer Bias	4					4	DSTP	200	1000pF	0.08uH	3.8E-07	9.6E-08	0	0	0	10	50%	33%	17%	1.18E-10	1.23E-12						
PMW Ground	1					0	S	50	1000pF	0.08uH	0.0E+00	0.0E+00	0	0	0	10	50%	33%	17%	0.00E+00	0.00E+00						
PMW JFET Heater	4					4	DSTP	200	1000pF	0.08uH	3.8E-03	9.6E-04	0	0	0	10	0%	33%	0%	1.18E-02	4.28E-07						
PLW JFET Heater	2					2	DSTP	200	1000pF	0.08uH	3.8E-03	9.6E-04	0	0	0	10	0%	33%	0%	5.92E-03	2.14E-07						
PLW JFET Bias	4					4	DSTP	100	1000pF	0.08uH	5.0E-03	1.2E-03	0	0	0	10	50%	33%	17%	1.00E-02	9.60E-05						
PLW Bolometer Bias	4					4	DSTP	200	1000pF	0.08uH	1.9E-07	4.8E-08	0	0	0	10	50%	33%	17%	2.95E-11	3.07E-13						
PLW Ground	1					0	S	50	1000pF	0.08uH	0.0E+00	0.0E+00	0	0	0	10	50%	33%	17%	0.00E+00	0.00E+00						
C4	CVW 4					HSJFP J21	MDM 25 P	HSJFP P21	MDM 25S	Bolometer signals from JFP (PMW 1-12)	24	6	DS 12-ax	500	1000pF	0.08uH	1.0E-09	5.0E-10	1	0	0	0.1	50%	33%	17%	1.20E-14	5.00E-16
										Anti-cross talk ground wires	12	NA	NA	500	1000pF	0.08uH	0.0E+00	0.0E+00	0	0	0	0.1	50%	33%	17%	0.00E+00	0.00E+00
		Bolometer signals from JFP (PMW 13-24)	24	6	DS 12-ax					500	1000pF	0.08uH	1.0E-09	5.0E-10	1	0	0	0.1	50%	33%	17%	1.20E-14	5.00E-16				
		Anti-cross talk ground wires	12	NA	NA					500	1000pF	0.08uH	0.0E+00	0.0E+00	0	0	0	0.1	50%	33%	17%	0.00E+00	0.00E+00				
		Bolometer signals from JFP (PMW 25-36)	24	6	DS 12-ax					500	1000pF	0.08uH	1.0E-09	5.0E-10	1	0	0	0.1	50%	33%	17%	1.20E-14	5.00E-16				
		Anti-cross talk ground wires	12	NA	NA					500	1000pF	0.08uH	0.0E+00	0.0E+00	0	0	0	0.1	50%	33%	17%	0.00E+00	0.00E+00				
		Bolometer signals from JFP (PMW 37-48)	24	6	DS 12-ax					500	1000pF	0.08uH	1.0E-09	5.0E-10	1	0	0	0.1	50%	33%	17%	1.20E-14	5.00E-16				
		Anti-cross talk ground wires	12	NA	NA					500	1000pF	0.08uH	0.0E+00	0.0E+00	0	0	0	0.1	50%	33%	17%	0.00E+00	0.00E+00				
		Bolometer signals from JFP (PMW 49-60)	24	6	DS 12-ax					500	1000pF	0.08uH	1.0E-09	5.0E-10	1	0	0	0.1	50%	33%	17%	1.20E-14	5.00E-16				
		Anti-cross talk ground wires	12	NA	NA					500	1000pF	0.08uH	0.0E+00	0.0E+00	0	0	0	0.1	50%	33%	17%	0.00E+00	0.00E+00				
		Bolometer signals from JFP (PMW 61-72)	24	6	DS 12-ax					500	1000pF	0.08uH	1.0E-09	5.0E-10	1	0	0	0.1	50%	33%	17%	1.20E-14	5.00E-16				
		Anti-cross talk ground wires	12	NA	NA					500	1000pF	0.08uH	0.0E+00	0.0E+00	0	0	0	0.1	50%	33%	17%	0.00E+00	0.00E+00				
		Bolometer signals from JFP (PMW 73-84)	24	6	DS 12-ax					500	1000pF	0.08uH	1.0E-09	5.0E-10	1	0	0	0.1	50%	33%	17%	1.20E-14	5.00E-16				
		Anti-cross talk ground wires	12	NA	NA					500	1000pF	0.08uH	0.0E+00	0.0E+00	0	0	0	0.1	50%	33%	17%	0.00E+00	0.00E+00				
Bolometer signals from JFP (PMW 85-96)	24	6	DS 12-ax	500	1000pF	0.08uH	1.0E-09	5.0E-10	1	0	0	0.1	50%	33%	17%	1.20E-14	5.00E-16										
Anti-cross talk ground wires	12	NA	NA	500	1000pF	0.08uH	0.0E+00	0.0E+00	0	0	0	0.1	50%	33%	17%	0.00E+00	0.00E+00										



SPIRE HARNESS DEFINITION DOCUMENT

Doc: SPIRE-RAL-PRJ-000608
Issue: 1.2
Date: 17/02/05
Page 238 of 245

Name	128 Way Connector	FPU/JFS/JFP Connector Label	Unit Connector Type	Harness Connector Label	Harness Connector Type	Description	Number of Conductors excl. shields	Number of Inner Shields	Implementation	Max. Impedance Requirements			Max. Current per Conductor	Average Current (see note B)	Operating Mode			Max. Volts	Duty Cycle			Peak Dissipation	Average Dissipation					
										R (W)	C (pF)	L (uH)			P	Sp	CR		t	T	(t x T)							
C6	CVW 6	HSJFP J13	MDM 25 P	HSJFP P13	MDM 25S	Bolometer signals from JFP (PLW 1-12)	24	6	DIS 12-ax	500	1000pF	0.09uH	1.0E-09	5.0E-10	1	0	0	0.1	50%	33%	17%	1.20E-14	5.00E-16					
						Anti-cross talk ground wires	12	NA		500	1000pF	0.09uH	0.0E+00	0.0E+00	0	0	0	0.1	50%	33%	17%	0.00E+00	0.00E+00					
						Type1																						
						HSJFP J14	MDM 25 P	HSJFP P14	MDM 25S	Bolometer signals from JFP (PLW 13-24)	24	6	DIS 12-ax	500	1000pF	0.09uH	1.0E-09	5.0E-10	1	0	0	0.1	50%	33%	17%	1.20E-14	5.00E-16	
						Anti-cross talk ground wires	12	NA																				
C7	CVW 7	HSJFP J15	MDM 25 P	HSJFP P15	MDM 25S	Bolometer signals from JFP (PLW 25-36)	24	6	DIS 12-ax	500	1000pF	0.09uH	1.0E-09	5.0E-10	1	0	0	0.1	50%	33%	17%	1.20E-14	5.00E-16					
						Anti-cross talk ground wires	12	NA																				
						Type1																						
						HSJFP J16	MDM 25 P	HSJFP P16	MDM 25S	Bolometer signals from JFP (PLW 37-48)	24	6	DIS 12-ax	500	1000pF	0.09uH	1.0E-09	5.0E-10	1	0	0	0.1	50%	33%	17%	1.20E-14	5.00E-16	
						Anti-cross talk ground wires	12	NA																				
C8	CVW 8	HSJFP J9	MDM 25 P	HSJFP P9	MDM 25S	Bolometer signals from JFP (FSW 1-12)	24	6	DIS 12-ax	500	1000pF	0.09uH	1.0E-09	5.0E-10	1	0	0	0.1	50%	33%	17%	1.20E-14	5.00E-16					
						Anti-cross talk ground wires	12	NA																				
						Type1																						
						HSJFP J10	MDM 25 P	HSJFP P10	MDM 25S	Bolometer signals from JFP (FSW 13-24)	24	6	DIS 12-ax	500	1000pF	0.09uH	1.0E-09	5.0E-10	1	0	0	0.1	50%	33%	17%	1.20E-14	5.00E-16	
						Anti-cross talk ground wires	12	NA																				
C9	CVW 9	HSJFP J11	MDM 25 P	HSJFP P11	MDM 25S	Bolometer signals from JFP (FSW 25-36)	24	6	DIS 12-ax	500	1000pF	0.09uH	1.0E-09	5.0E-10	1	0	0	0.1	50%	33%	17%	1.20E-14	5.00E-16					
						Anti-cross talk ground wires	12	NA																				
						Type1																						
						HSJFP J12	MDM 25 P	HSJFP P12	MDM 25S	Bolometer signals from JFP (FSW 37-48)	24	6	DIS 12-ax	500	1000pF	0.09uH	1.0E-09	5.0E-10	1	0	0	0.1	50%	33%	17%	1.20E-14	5.00E-16	
						Anti-cross talk ground wires	12	NA																				
C10	CVW 8	HSJFP J5	MDM 25 P	HSJFP P5	MDM 25S	Bolometer signals from JFP (FSW 49-60)	24	6	DIS 12-ax	500	1000pF	0.09uH	1.0E-09	5.0E-10	1	0	0	0.1	50%	33%	17%	1.20E-14	5.00E-16					
						Anti-cross talk ground wires	12	NA																				
						Type1																						
						HSJFP J6	MDM 25 P	HSJFP P6	MDM 25S	Bolometer signals from JFP (FSW 61-72)	24	6	DIS 12-ax	500	1000pF	0.09uH	1.0E-09	5.0E-10	1	0	0	0.1	50%	33%	17%	1.20E-14	5.00E-16	
						Anti-cross talk ground wires	12	NA																				
C11	CVW 9	HSJFP J7	MDM 25 P	HSJFP P7	MDM 25S	Bolometer signals from JFP (FSW 73-84)	24	6	DIS 12-ax	500	1000pF	0.09uH	1.0E-09	5.0E-10	1	0	0	0.1	50%	33%	17%	1.20E-14	5.00E-16					
						Anti-cross talk ground wires	12	NA																				
						Type1																						
						HSJFP J8	MDM 25 P	HSJFP P8	MDM 25S	Bolometer signals from JFP (FSW 85-96)	24	6	DIS 12-ax	500	1000pF	0.09uH	1.0E-09	5.0E-10	1	0	0	0.1	50%	33%	17%	1.20E-14	5.00E-16	
						Anti-cross talk ground wires	12	NA																				
C12	CVW 9	HSJFP J1	MDM 25 P	HSJFP P1	MDM 25S	Bolometer signals from JFP (FSW 97-108)	24	6	DIS 12-ax	500	1000pF	0.09uH	1.0E-09	5.0E-10	1	0	0	0.1	50%	33%	17%	1.20E-14	5.00E-16					
						Anti-cross talk ground wires	12	NA																				
						Type1																						
						HSJFP J2	MDM 25 P	HSJFP P2	MDM 25S	Bolometer signals from JFP (FSW 109-120)	24	6	DIS 12-ax	500	1000pF	0.09uH	1.0E-09	5.0E-10	1	0	0	0.1	50%	33%	17%	1.20E-14	5.00E-16	
						Anti-cross talk ground wires	12	NA																				
C13	CVW 9	HSJFP J3	MDM 25 P	HSJFP P3	MDM 25S	Bolometer signals from JFP (FSW 121-132)	24	6	DIS 12-ax	500	1000pF	0.09uH	1.0E-09	5.0E-10	1	0	0	0.1	50%	33%	17%	1.20E-14	5.00E-16					
						Anti-cross talk ground wires	12	NA																				
						Type1																						
C14	CVW 9	HSJFP J4	MDM 25 P	HSJFP P4	MDM 25S	Bolometer signals from JFP (FSW 133-144)	24	6	DIS 12-ax	500	1000pF	0.09uH	1.0E-09	5.0E-10	1	0	0	0.1	50%	33%	17%	1.20E-14	5.00E-16					
						Anti-cross talk ground wires	12	NA																				



SPIRE HARNESS DEFINITION DOCUMENT

Doc: SPIRE-RAL-PRJ-000608
 Issue: 1.2
 Date: 17/02/05
 Page 239 of 245

Name	128 Way Connector	FPU/FS/JFP Connector Label	Unit Connector Type	Harness Connector Label	Harness Connector Type	Description	Number of Conductors excl. shields	Number of Inner Shields	Implementation	Max. Impedance Requirements			Max. Current per Conductor	Average Current (see note 9)	Operating Mode			Max. Volts	Duty Cycle			Peak Dissipation	Average Dissipation
										R (W)	C (pF)	L (uH)			P	Sp	CR		t	T	(t x T)		
C10	CVV 10	HSFPU J19	MDM 37 S	HSFPU P19	MDM 37P	Sorption Pump Heater	4	0	TQ	10		2.5E-02	6.3E-03	0	0	1		2%	33%	1%	2.50E-02	1.09E-05	
						Evaporator HS Heater	4	0	TQ	50		1.5E-03	3.8E-04	0	0	1							
Aux-P						Sorption Pump HS heater	4	0	TQ	50		1.5E-03	3.8E-04	1	1	1		2%	33%	1%	4.50E-04	1.95E-07	
						Various cooler thermistors	20	10	STQ	1000		1.0E-05	1.0E-06	1	1	1		100%	33%	33%	2.00E-08	6.66E-09	
						Spectrometer Stimulus Thermistors	12	6	STQ	1000		1.0E-05	1.0E-06	1	1	0		100%	33%	33%	1.20E-08	4.00E-09	
						Spectrometer Stimulus Heater 4%	4	0	TQ	30		9.0E-03	2.3E-03	0	1	0		50%	33%	0.1665	9.72E-03	1.01E-04	
						Spectrometer Stimulus Heater 2%	4	0	TQ	30		7.0E-03	1.8E-03	0	1	0		50%	33%	17%	5.88E-03	6.12E-05	
						FPU Thermometry	24	12	STQ	1000		1.0E-05	1.0E-06	1	1	1		100%	33%	33%	2.40E-08	8.00E-09	
						300mK Thermal Control Heater	4	2	STQ	30		2.0E-03	5.0E-04	1	0	0		50%	33%	17%	4.80E-04	5.00E-05	
						BSM Chopper Sensors	3	1	STP	1000		1.0E-05	1.0E-06	1	1	0		0.4	40%	33%	13%	3.00E-09	3.98E-10
						BSM Jiggle Sensors	3	1	STP	1000		1.0E-05	1.0E-06	1	1	0		40%	33%	13%	3.00E-09	3.98E-10	
						BSM Temperature	4	2	STQ	1000		1.0E-05	1.0E-06	1	1	1		100%	33%	33%	4.00E-09	1.32E-09	
C11	CVV 11	HSFPU J25	MDM 37 S	HSFPU P25	MDM 37P	Photometer Stimulus Heater	4	2	STQ	10		7.0E-03	1.8E-03	1	0	0		5%	33%	2%	1.95E-03	2.02E-05	
						BSM Launch latch sense	2	1	STP	1000		1.00E-03	0	0	0	0		0%	0%	0%	2.00E-03	0.00E+00	
						BSM Launch latch solenoid	2	1	STP	10		3.5E-02	0	0	0	0		0%	0%	0%	2.45E-02	0.00E+00	
						BSM Chop motor drive	4	2	STQ	10		4.0E-02	2.0E-02	1	1	0		40%	33%	13%	6.40E-02	2.11E-03	
						BSM Jiggle motor drive	4	2	STQ	10		4.0E-02	5.0E-03	1	1	0		40%	33%	13%	6.40E-02	1.32E-04	
						SMEC Thermometry	8	4	STQ	1000		1.0E-05	1.0E-06	1	1	1		100%	33%	33%	8.00E-09	2.64E-09	
						SMEC LVDT Primary	2	1	STP	5		5.0E-03	2.50E-03	0	1	0	5	50%	33%	17%	2.50E-04	1.03E-05	
						SMEC LVDT Secondary	4	2	STP	50		5.0E-05	5.0E-02	0	1	0	15	50%	33%	17%	5.00E-07	8.20E-02	
						SMEC Launch Latch	4	2	STP	5		4.0E-01	0.0E+00	0	0	0	15	0%	0%	0%	3.20E+00	0.00E+00	
						SMEC Launch Latch (Rob.)	4	2	STP	5		4.0E-01	0.0E+00	0	0	0	15	0%	0%	0%	3.20E+00	0.00E+00	
						SMEC Launch Latch Confirm	4	2	STP	5		1.0E-03	0.0E+00	0	0	0	15	0%	0%	0%	3.00E-05	0.00E+00	
						SMEC Drive Coil	2	1	STP	5		1.0E-01	4.0E-02	0	1	0	15	50%	33%	17%	1.00E-01	2.64E-03	
						SMEC Drive (Rob.)	2	1	STP	5		1.0E-01	4.0E-02	0	1	0	15	50%	33%	17%	1.00E-01	2.64E-03	
						SMEC Drive coil voltage sensor	2	1	STP	500		1.0E-05	1.0E-05	0	1	0	15	50%	33%	17%	1.00E-07	1.60E-08	
						SMEC Position sensor supplies	2	1	STP	100		1.0E-03	1.0E-03	0	1	0	5	50%	33%	17%	2.00E-04	3.30E-05	
						SMEC LED Power	2	1	STP	100		1.0E-03	8.0E-04	0	1	0	5	50%	33%	17%	2.00E-04	2.11E-05	
						SMEC Position sensor photodiodes	6	3	STP	1000		2.0E-05	2.0E-05	0	1	0	5	50%	33%	17%	2.40E-06	3.98E-07	
						SMEC Position sensor photodiodes FB	6	3	STP	1000		1.0E-05	1.0E-05	0	1	0	5	50%	33%	17%	6.00E-07	9.90E-08	

Name	128 Way Connector	FPU/FS/JFP Connector Label	Unit Connector Type	Harness Connector Label	Harness Connector Type	Description	Number of Conductors excl. shields	Number of Inner Shields	Implementation	Max. Impedance Requirements			Max. Current per Conductor	Average Current (see note 9)	Operating Mode			Max. Volts	Duty Cycle			Peak Dissipation	Average Dissipation
										R (W)	C (pF)	L (uH)			P	Sp	CR		t	T	(t x T)		
C12	CVV 12	HSFPU J20	MDM 37 S	HSFPU P20	MDM 37P	Sorption Pump Heater	4	0	TQ	10		2.5E-02	0	0	0		2%	33%	1%	2.50E-02	0.00E+00		
						Heat switch heaters	8	0	TQ	50		1.5E-03	0	0	0	0		2%	33%	1%	9.00E-04	0.00E+00	
Aux-R						Various cooler thermistors	20	10	STQ	1000		1.0E-05	0	0	0		100%	33%	33%	2.00E-08	0.00E+00		
						Spectrometer Stimulus Thermistors	12	6	STQ	1000		1.0E-05	0	0	0	0		100%	33%	33%	1.20E-08	0.00E+00	
						Spectrometer Stimulus Heater 4%	4	0	TQ	30		9.0E-03	0	0	0	0		50%	33%	0.1665	9.72E-03	0.00E+00	
						Spectrometer Stimulus Heater 2%	4	0	TQ	30		7.0E-03	0	0	0	0		50%	33%	17%	5.88E-03	0.00E+00	
						FPU Thermometry	24	12	STQ	1000		1.0E-05	0	0	0	0		100%	33%	33%	2.40E-08	0.00E+00	
						300mK Thermal Control Heater	4	2	STQ	30		2.0E-03	0	0	0	0		50%	33%	17%	4.80E-04	0.00E+00	
						BSM Chopper Sensors	3	1	STT	1000		1.0E-05	0	0	0	0	0.4	40%	33%	13%	3.00E-09	0.00E+00	
						BSM Jiggle Sensors	3	1	STT	1000		1.0E-05	0	0	0	0	0	40%	33%	13%	3.00E-09	0.00E+00	
						BSM Temperature	4	2	STQ	1000		1.0E-05	0	0	0	0	0	40%	33%	13%	2.00E-09	0.00E+00	
						Photometer Stimulus Heater	4	2	STQ	1000		1.0E-05	0	0	0	0	0	100%	33%	33%	4.00E-09	0.00E+00	
C13	CVV13	HSFPU J26	MDM 37 S	HSFPU P26	MDM 37P	BSM Launch latch sense	2	1	STP	1000		1.00E-03	0	0	0	0		0%	0%	0%	2.00E-03	0.00E+00	
						BSM Launch latch solenoid	2	1	STP	10		3.5E-02	0	0	0	0		0%	0%	0%	2.45E-02	0.00E+00	
						BSM Chop motor drive	4	2	STQ	10		4.0E-02	0	0	0	0		40%	33%	13%	6.40E-02	0.00E+00	
						BSM Jiggle motor drive	4	2	STQ	10		4.0E-02	0	0	0	0		40%	33%	13%	6.40E-02	0.00E+00	
						SMEC Thermometry	8	4	STQ	1000		1.0E-05	0	0	0	0		100%	33%	33%	8.00E-09	0.00E+00	
						SMEC LVDT Primary	2	1	STP	5		5.0E-03	0	0	0	0	5	50%	33%	17%	2.50E-04	0.00E+00	
						SMEC LVDT Secondary	4	2	STP	50		5.0E-05	0	0	0	0	15	50%	33%	17%	5.00E-07	0.00E+00	
						SMEC Launch Latch	4	2	STP	5		4.0E-01	0	0	0	0	15	0%	0%	0%	3.20E+00	0.00E+00	
						SMEC Launch Latch (Rob.)	4	2	STP	5		4.0E-01	0	0	0	0	15	0%	0%	0%	3.20E+00	0.00E+00	
						SMEC Launch Latch Confirm	4	2	STP	5		1.0E-03	0	0	0	0	15	0%	0%	0%	2.00E-05	0.00E+00	
						SMEC Drive Coil	2	1	STP	5		1.0E-01	0	0	0	0	15	50%	33%	17%	1.00E-01	0.00E+00	
						SMEC Drive (Rob.)	2	1	STP	5		1.0E-01	0	0	0	0	15	50%	33%	17%	1.00E-01	0.00E+00	
						SMEC Drive coil voltage sensor	2	1	STP	500		1.0E-05	0	0	0	0	15	50%	33%	17%	1.00E-07	0.00E+00	
						SMEC Position sensor supplies	2	1	STP	100		1.0E-03	0	0	0	0	5	50%	33%	17%	2.00E-04	0.00E+00	
						SMEC LED Power	2	1	STP	100		1.0E-03	0	0	0	0	5	50%	33%	17%	2.00E-04	0.00E+00	
						SMEC Position sensor photodiodes	6	3	STP	1000		2.0E-05	0	0	0	0	5	50%	33%	17%	2.40E-06	0.00E+00	
						SMEC Position sensor photodiodes FB	6	3	STP	1000		1.0E-05	0	0	0	0	5	50%	33%	17%	6.00E-07	0.00E+00	



SPIRE HARNESS DEFINITION DOCUMENT

Doc: SPIRE-RAL-PRJ-000608
Issue: 1.2
Date: 17/02/05
Page 240 of 245

ANNEX 2 – External Cryostat Wiring List

- The impedance values quoted in the tables refer to the total impedance for the “I-Harness” between the SVM Connector Panel and the Warm Electronics units and the “E-Harness” between the CVV 128-Way Connector and the SVM Connector Panel. The “I-Harness” is to be constructed from 28 AWG stranded Copper conductors as specified in §4.1.
- The BSM and SMEC Launch lock confirm cables and the Shutter tails terminate at skin connectors near the CVV 128-Way connectors. Shading indicates these functions.
- * On each harness, a continuous braided RF overshield joined to the backs of the CVV connectors, passing through the SVM bracket connectors via their backshells and joining to the DRCU connector backshells
- This is the listing for the S-Harnesses. The impedance values are assumed to apply to the I-Harnesses

Name	128 Way Connector	DRCU Connector Label	DRCU Connector Type	Harness Connector Label	Harness Connector Type	Description	Number of Conductors excl. shlds	Number of inner Shields	Implementation	Max. Impedance			Max. Current per Conductor	Average	Operating Mode			Max. Volts	Duty Cycle			Peak Dissipation	Average					
										R (W)	C(pF)	L(uH)			P	Sp	CR		t	T	(t x T)							
11/51 Type3	CVV 1	DCU J27	DCMA37 P	DCU P27	DCMA 37S	Botometer signals from JFS (SLW 1-12)	24	12	STP	500	1500pF	0.08uH	1.00E-09	5.00E-10	0	1	0	0.1	50%	33%	17%	1.20E-14	5.00E-16					
						SLW Ground	1	0	S	50	1500pF	0.08uH	0	0	0	0	0.1	50%	0%	0%	0.00E+00	0.00E+00						
						Botometer signals from JFS (SLW 13-24)	24	12	STP	500	1500pF	0.08uH	1.00E-09	5.00E-10	0	1	0	0.1	50%	33%	17%	1.20E-14	5.00E-16					
						SLW Ground	1	0	S	50	1500pF	0.08uH	0	0	0	0	0.1	0%	0%	0%	0.00E+00	0.00E+00						
						PTC Bias	2	2	STP	100	1500pF	0.08uH	3.20E-08	8.00E-09	1	0	0	10	50%	33%	17%	2.05E-13	2.13E-15					
						PTC Ground wire	1	0	S	50	1500pF	0.08uH	0	0	0	0	10	50%	33%	17%	0	0						
						PTC JFET Bias	2	2	STP	100	1500pF	0.08uH	5.00E-03	2.00E-04	1	0	0	10	50%	33%	17%	5.00E-03	1.33E-06					
						SLW Botometer Bias	4	4	STP	100	1500pF	0.08uH	9.60E-08	2.40E-08	0	1	0	10	50%	33%	17%	3.69E-12	3.84E-14					
						SLW JFET Bias	4	4	STP	100	1500pF	0.08uH	2.50E-03	6.00E-04	0	1	0	10	50%	33%	17%	2.50E-03	2.40E-05					
						SLW Ground wire	1	0	S	50	1500pF	0.08uH	0	0	0	0	10	50%	33%	17%	0	0						
						SSW Botometer Bias	4	4	STP	100	1500pF	0.08uH	1.20E-03	4.80E-08	0	1	0	10	50%	33%	17%	5.76E-04	1.54E-13					
						SSW JFET Bias	4	4	STP	100	1500pF	0.08uH	5.00E-03	1.20E-03	0	1	0	10	50%	33%	17%	1.00E-02	9.60E-05					
						SSW Ground Wire	1	0	S	50	1500pF	0.08uH	0	0	0	0	10	50%	33%	17%	0	0						
						PTC JFET Heater	2	2	STP	200	1500pF	0.08uH	1.92E-03	4.81E-04	0	0	0	10	0.2%	33%	0%	1.48E-03	5.35E-08					
						SLW JFET Heater	2	2	STP	200	1500pF	0.08uH	3.33E-03	8.33E-04	0	0	0	10	0.2%	33%	0%	4.44E-03	1.61E-07					
						SSW JFET Heater	2	2	STP	200	1500pF	0.08uH	6.67E-03	1.67E-03	0	0	0	10	0.2%	33%	0%	1.78E-02	6.43E-07					
						PTC Bias	2	2	STP	100	1500pF	0.08uH	3.20E-08	8.00E-09	0	0	0	10	50%	33%	17%	2.05E-13	2.13E-15					
						PTC Ground wire	1	0	S	50	1500pF	0.08uH	0	0	0	0	10	50%	33%	17%	0	0						
						PTC JFET Bias	2	2	STP	100	1500pF	0.08uH	5.00E-03	2.00E-04	0	0	0	10	50%	33%	17%	5.00E-03	1.33E-06					
						SLW Botometer Bias	4	4	STP	100	1500pF	0.08uH	9.60E-08	2.40E-08	0	0	0	10	50%	33%	17%	3.69E-12	3.84E-14					
						SLW JFET Bias	4	4	STP	100	1500pF	0.08uH	2.50E-03	6.00E-04	0	0	0	10	50%	33%	17%	2.50E-03	2.40E-05					
SLW Ground wire	1	0	S	50	1500pF	0.08uH	0	0	0	0	10	50%	33%	17%	0	0												
SSW Botometer Bias	4	4	STP	100	1500pF	0.08uH	1.20E-03	4.80E-08	0	0	0	10	50%	33%	17%	5.76E-04	1.54E-13											
SSW JFET Bias	4	4	STP	100	1500pF	0.08uH	5.00E-03	1.20E-03	0	0	0	10	50%	33%	17%	1.00E-02	9.60E-05											
SSW Ground Wire	1	0	S	50	1500pF	0.08uH	0	0	0	0	10	50%	33%	17%	0	0												
PTC JFET Heater	2	2	STP	200	1500pF	0.08uH	1.92E-03	4.81E-04	0	0	0	10	0.2%	33%	0%	1.48E-03	5.35E-08											
SLW JFET Heater	2	2	STP	200	1500pF	0.08uH	3.33E-03	8.33E-04	0	0	0	10	0.2%	33%	0%	4.44E-03	1.61E-07											
SSW JFET Heater	2	2	STP	200	1500pF	0.08uH	6.67E-03	1.67E-03	0	0	0	10	0.2%	33%	0%	1.78E-02	6.43E-07											
RF Overshield								>80%																				
12/52	CVV 2	DCU J23	DCMA37 P	DCU P23	DCMA 37 S	Botometer signals from JFS (SSW 1-12)	24	12	STP	500	1500pF	0.08uH	1.00E-09	5.00E-10	0	1	0	0.1	50%	33%	17%	1.20E-14	5.00E-16					
						Botometer signals from JFS (SSW 13-24)	24	12	STP	500	1500pF	0.08uH	1.00E-09	5.00E-10	0	1	0	0.1	50%	33%	17%	1.20E-14	5.00E-16					
						SSW Ground Wire	1	0	Single	50	1500pF	0.08uH	0.0	0.0	0	0	0.1	50%	33%	17%	0.00E+00	0.00E+00						
						Botometer signals from JFS (SSW 25-36)	24	12	STP	500	1500pF	0.08uH	1.00E-09	5.00E-10	0	1	0	0.1	50%	33%	17%	1.20E-14	5.00E-16					
						Botometer signals from JFS (SSW 37-42)	12	6	STP	500	1500pF	0.08uH	1.00E-09	5.00E-10	0	1	0	0.1	50%	33%	17%	8.00E-15	2.50E-16					
						SSW Ground Wire	1	0	Single	50	1500pF	0.08uH	0.0	0.0	0	0	0.1	50%	33%	17%	0.00E+00	0.00E+00						
						RF Overshield							>80%															
						RF Overshield								>80%														
						RF Overshield								>80%														
						RF Overshield								>80%														



SPIRE HARNESS DEFINITION DOCUMENT

Doc: SPIRE-RAL-PRJ-000608

Issue: 1.2

Date: 17/02/05

Page 241 of 245

Name	128 Way Connector	DRCU Connector Label	DRCU Connector Type	Harness Connector Label	Harness Connector Type	Description	Number of Conductors excl. shields	Number of inner Shields	Implementation	R (W)	C(pF)	L(uH)	Max.Current per Conductor	Average	Operating Mode P Sp CR	Max. Volts	t	Duty Cycle T	(t x T)	Peak Dissipation	Average						
16/53 Type2	CVV 3	DCU J29	DDMA 78S	DCU P29	DDMA 78 P	PSW JFET Bias	12	12	STP	100	1500pF	0.08uH	5.00E-03	1.20E-03	1 0 0	10	50%	33%	17%	3.00E-02	2.88E-04						
						PSW Ground	1	0	S	50	1500pF	0.08uH	0	0	0 0 0	10	50%	33%	17%	0.00E+00	0.00E+00						
						PSW Bolometer Bias	6	6	STP	100	1500pF	0.08uH	3.84E-07	9.60E-08	1 0 0	10	50%	33%	17%	8.85E-11	9.22E-13						
						PSW Heater	6	6	STP	200	1500pF	0.08uH	3.85E-03	9.62E-04	0 0 0	10	0.2%	33%	0%	1.18E-02	6.42E-07						
						PMW JFET Bias	8	8	STP	100	1500pF	0.08uH	5.00E-03	1.20E-03	1 0 0	10	50%	33%	17%	2.00E-02	1.92E-04						
						PMW Bolometer Bias	4	4	STP	100	1500pF	0.08uH	3.84E-07	9.60E-08	1 0 0	10	50%	33%	17%	5.90E-11	6.14E-13						
						PMW Ground	1	0	S	50	1500pF	0.08uH	0	0	0 0 0	10	50%	33%	17%	0.00E+00	0.00E+00						
						PMW JFET Heater	4	4	STP	200	1500pF	0.08uH	3.85E-03	9.62E-04	0 0 0	10	0.2%	33%	0%	1.18E-02	4.28E-07						
						PLW JFET Heater	2	2	STP	200	1500pF	0.08uH	3.85E-03	9.62E-04	0 0 0	10	0.2%	33%	0%	5.92E-03	2.14E-07						
						PLW JFET Bias	4	4	STP	100	1500pF	0.08uH	5.00E-03	1.20E-03	1 0 0	10	50%	33%	17%	1.00E-02	9.60E-05						
						PLW Bolometer Bias	4	4	STP	100	1500pF	0.08uH	1.92E-07	4.80E-08	1 0 0	10	50%	33%	17%	1.47E-11	1.54E-13						
						PLW Ground	1	0	S	50	1500pF	0.08uH	0	0	0 0 0	10	50%	33%	17%	0.00E+00	0.00E+00						
						16/54 Type1	CVV 4	DCU J30	DDMA 78S	DCU P30	DDMA 78 P	PSW JFET Bias	12	12	STP	100	1500pF	0.08uH	5.00E-03	1.20E-03	0 0 0	10	50%	33%	17%	3.00E-02	2.88E-04
PSW Ground	1	0	S	50	1500pF							0.08uH	0.00E+00	0.00E+00	0 0 0	10	50%	33%	17%	0.00E+00	0.00E+00						
PSW Bolometer Bias	6	6	STP	100	1500pF							0.08uH	0.0	0.0	0 0 0	10	50%	33%	17%	8.85E-11	9.22E-13						
PSW Heater	6	6	STP	200	1500pF							0.08uH	3.85E-03	9.62E-04	0 0 0	10	0%	33%	0%	1.18E-02	6.42E-07						
PMW JFET Bias	8	8	STP	100	1500pF							0.08uH	5.00E-03	1.20E-03	0 0 0	10	50%	33%	17%	2.00E-02	1.92E-04						
PMW Bolometer Bias	4	4	STP	100	1500pF							0.08uH	3.84E-07	9.60E-08	0 0 0	10	50%	33%	17%	5.90E-11	6.14E-13						
PMW Ground	1	0	S	50	1500pF							0.08uH	0	0	0 0 0	10	50%	33%	17%	0.00E+00	0.00E+00						
PMW JFET Heater	4	4	STP	200	1500pF							0.08uH	3.85E-03	9.62E-04	0 0 0	10	0%	33%	0%	1.18E-02	4.28E-07						
PLW JFET Heater	2	2	STP	200	1500pF							0.08uH	3.85E-03	9.62E-04	0 0 0	10	0%	33%	0%	5.92E-03	2.14E-07						
PLW JFET Bias	4	4	STP	100	1500pF							0.08uH	5.00E-03	1.20E-03	0 0 0	10	50%	33%	17%	1.00E-02	9.60E-05						
PLW Bolometer Bias	4	4	STP	100	1500pF							0.08uH	1.92E-07	4.80E-08	0 0 0	10	50%	33%	17%	1.47E-11	1.54E-13						
PLW Ground	1	0	S	50	1500pF							0.08uH	0	0	0 0 0	10	50%	33%	17%	0.00E+00	0.00E+00						
RF Overshield	>80%																										
16/55 Type1	CVV 4	DCU J20	DDMA 50 P	DCU P20	DDMA 50 S	16 ch PMW (1-16)	32	16	STP	500	1500pF	0.08uH	1.00E-09	5E-10	1 0 0	0.1	50%	33%	17%	1.80E-14	6.87E-16						
						Ground Wire	1	0	S	50	1500pF	0.08uH	0	0	0 0 0	0.1	50%	33%	17%	0.00E+00	0.00E+00						
						16 ch PMW (17-32)	32	16	STP	500	1500pF	0.08uH	1.00E-09	5E-10	1 0 0	0.1	50%	33%	17%	1.80E-14	6.87E-16						
						Ground Wire	1	0	S	50	1500pF	0.08uH	0	0	0 0 0	0.1	50%	33%	17%	0.00E+00	0.00E+00						
						16 ch PMW (33-48)	32	16	STP	500	1500pF	0.08uH	1.00E-09	5E-10	1 0 0	0.1	50%	33%	17%	1.80E-14	6.87E-16						
						Ground Wire	1	0	S	50	1500pF	0.08uH	0	0	0 0 0	0.1	50%	33%	17%	0.00E+00	0.00E+00						
						RF Overshield	>80%																				
						16/56 Type1	CVV 5	DCU J17	DDMA 50 P	DCU P17	DDMA 50 S	16 ch PMW (49-64)	32	16	STP	500	1500pF	0.08uH	1.00E-09	5E-10	1 0 0	0.1	50%	33%	17%	1.80E-14	6.87E-16
												Ground Wire	1	0	S	50	1500pF	0.08uH	0	0	0 0 0	0.1	50%	33%	17%	0.00E+00	0.00E+00
												16 ch PMW (65-80)	32	16	STP	500	1500pF	0.08uH	1.00E-09	5E-10	1 0 0	0.1	50%	33%	17%	1.80E-14	6.87E-16
												Ground Wire	2	0	S	50	1500pF	0.08uH	0	0	0 0 0	0.1	50%	33%	17%	0.00E+00	0.00E+00
												16 ch PMW (81-96)	32	16	STP	500	1500pF	0.08uH	1.00E-09	5E-10	1 0 0	0.1	50%	33%	17%	1.80E-14	6.87E-16
												Ground Wire	1	0	S	50	1500pF	0.08uH	0	0	0 0 0	0.1	50%	33%	17%	0.00E+00	0.00E+00
RF Overshield	>80%																										
16/57 Type1	CVV 6	DCU J14	DDMA 50 P	DCU P14	DDMA 50 S							16 ch PLW (1-16)	32	16	STP	500	1500pF	0.08uH	1.00E-09	5E-10	1 0 0	0.1	50%	33%	17%	1.80E-14	6.87E-16
												Ground Wire	1	0	S	50	1500pF	0.08uH	0	0	0 0 0	0.1	50%	33%	17%	0.00E+00	0.00E+00
												16 ch PLW (17-32)	32	16	STP	500	1500pF	0.08uH	1.00E-09	5E-10	1 0 0	0.1	50%	33%	17%	1.80E-14	6.87E-16
												Ground Wire	1	0	S	50	1500pF	0.08uH	0	0	0 0 0	0.1	50%	33%	17%	0.00E+00	0.00E+00
												16 ch PLW (33-48)	32	16	STP	500	1500pF	0.08uH	1.00E-09	5E-10	1 0 0	0.1	50%	33%	17%	1.80E-14	6.87E-16
												Ground Wire	1	0	S	50	1500pF	0.08uH	0	0	0 0 0	0.1	50%	33%	17%	0.00E+00	0.00E+00
						RF Overshield	>80%																				
						17/57 Type1	CVV 7	DCU J11	DDMA 50 P	DCU P11	DDMA 50 S	16 ch PSW (1-16)	32	16	STP	500	1500pF	0.08uH	1.00E-09	5E-10	1 0 0	0.1	50%	33%	17%	1.80E-14	6.87E-16
												Ground Wire	1	0	S	50	1500pF	0.08uH	0	0	0 0 0	0.1	50%	33%	17%	0.00E+00	0.00E+00
												16 ch PSW (17-32)	32	16	STP	500	1500pF	0.08uH	1.00E-09	5E-10	1 0 0	0.1	50%	33%	17%	1.80E-14	6.87E-16
												Ground Wire	1	0	S	50	1500pF	0.08uH	0	0	0 0 0	0.1	50%	33%	17%	0.00E+00	0.00E+00
												16 ch PSW (33-48)	32	16	STP	500	1500pF	0.08uH	1.00E-09	5E-10	1 0 0	0.1	50%	33%	17%	1.80E-14	6.87E-16
												Ground Wire	1	0	S	50	1500pF	0.08uH	0	0	0 0 0	0.1	50%	33%	17%	0.00E+00	0.00E+00
RF Overshield	>80%																										
18/58 Type1	CVV 8	DCU J8	DDMA 50 P	DCU P8	DDMA 50 S							16 ch PSW (49-64)	32	16	STP	500	1500pF	0.08uH	1.00E-09	5E-10	1 0 0	0.1	50%	33%	17%	1.80E-14	6.87E-16
												Ground Wire	1	0	S	50	1500pF	0.08uH	0	0	0 0 0	0.1	50%	33%	17%	0.00E+00	0.00E+00
												16 ch PSW (65-80)	32	16	STP	500	1500pF	0.08uH	1.00E-09	5E-10	1 0 0	0.1	50%	33%	17%	1.80E-14	6.87E-16
												Ground Wire	1	0	S	50	1500pF	0.08uH	0	0	0 0 0	0.1	50%	33%	17%	0.00E+00	0.00E+00
												16 ch PSW (81-96)	32	16	STP	500	1500pF	0.08uH	1.00E-09	5E-10	1 0 0	0.1	50%	33%	17%	1.80E-14	6.87E-16
												Ground Wire	1	0	S	50	1500pF	0.08uH	0	0	0 0 0	0.1	50%	33%	17%	0.00E+00	0.00E+00
						RF Overshield	>80%																				
						18/59 Type1	CVV 9	DCU J5	DDMA 50 P	DCU P5	DDMA 50 S	16 ch PMW (97-112)	32	16	STP	500	1500pF	0.08uH	1.00E-09	5E-10	1 0 0	0.1	50%	33%	17%	1.80E-14	6.87E-16
												Ground Wire	1	0	S	50	1500pF	0.08uH	0	0	0 0 0	0.1	50%	33%	17%	0.00E+00	0.00E+00
												16 ch PMW (113-128)	32	16	STP	500	1500pF	0.08uH	1.00E-09	5E-10	1 0 0	0.1	50%	33%	17%	1.80E-14	6.87E-16
												Ground Wire	1	0	S	50	1500pF	0.08uH	0	0	0 0 0	0.1	50%	33%	17%	0.00E+00	0.00E+00
												16 ch PMW (129-144)	32	16	STP	500	1500pF	0.08uH	1.00E-09	5E-10	1 0 0	0.1	50%	33%	17%	1.80E-14	6.87E-16
												Ground Wire	1	0	S	50	1500pF	0.08uH	0	0	0 0 0	0.1	50%	33%	17%	0.00E+00	0.00E+00
RF Overshield	>80%																										



SPIRE HARNESS DEFINITION DOCUMENT

Doc: SPIRE-RAL-PRJ-000608
Issue: 1.2
Date: 17/02/05
Page 242 of 245

Name	128 Way Connector	DRCU Connector Label	DRCU Connector Type	Harness Connector Label	Harness Connector Type	Description	Number of Conductors excl. shlds	Number of inner Shields	Implementation	Max. Impedance			Max. Current per Conductor	Average	Operating Mode			Max. Volts	Duty Cycle			Peak Dissipation	Average										
										R (W)	C(pF)	L(uH)			P	Sp	CR		t	T	(t x T)												
H16/S10 Aux-P	CVV 10	FCU J11	DBMA 25 S	FCU P11	DBMA 25 P	Sorption Pump Heater	4	0	TQ	10			2.50E-02	6.25E-03	0	0	1		2%	1/3	1%	2.50E-02	1.00E-05										
						Evaporator HS Heater	4	0	TQ	50			1.50E-03	3.75E-04	0	0	1																
						Sorption Pump HS heater	4	0	TQ	50			1.50E-03	3.75E-04	1	1	1					2%	1/3	1%	4.50E-04	1.95E-07							
						300mK Thermal Control Heater	4	1	STQ	100			2.00E-03	5.00E-04	1	0	0						50%	33.30%	17%	1.60E-03	1.67E-05						
						Spectrometer Stimulus Heater 4%	4	0	TQ	30			9.00E-03	2.25E-03	0	1	0						50%	33.30%	17%	9.72E-03	1.01E-04						
						Spectrometer Stimulus Heater 2%	4	0	TQ	30			7.00E-03	1.75E-03	0	1	0						50%	33.30%	17%	5.88E-03	6.12E-05						
						FPU Thermometry A	44	11	STQ	1000			1.00E-06	1.00E-06	1	1	1						100%	33%	33%	4.40E-08	1.45E-08						
						FPU Thermometry B	12	3	STQ	1000			1.00E-06	1.00E-06	1	1	1						100%	33%	33%	1.20E-06	3.96E-09						
						RF Overshield							>80%																0.00E+00				
						H11/S11 Drive-P	CVV 11	FCU J21	DAMA 15 S	FCU P21	DAMA 15 P	FPU Thermometry C	12	3	STQ	1000			1.00E-06	0.000001	1	1	1		100%	33%	33%	1.20E-08	3.96E-09				
BSM Chop/Juggle Sensors	4	2	STP	1000									1.00E-06	1.00E-06	1	1	0	0.4				100%	33%	33%	4.00E-09	1.32E-09							
BSM Chop/Juggle Sensors	6	2	STT	1000									1.00E-06	1.00E-06	1	1	0						100%	33%	33%	6.00E-09	1.98E-09						
BSM Launch latch sense	2	1	STP	1000									0.001	0	0	0	0						0%	0%	0%	2.00E-03	0.00E+00						
BSM Launch latch solenoid	2	1	STP	10									0.035	0	0	0	0						0%	0%	0%	2.45E-02	0.00E+00						
BSM Chop motor drive	4	1	STQ	10									0.04	0.02	1	1	0						50%	33%	17%	6.40E-02	2.64E-03						
BSM Juggle motor drive	4	1	STQ	10									0.04	0.005	1	1	0						50%	33%	17%	6.40E-02	1.66E-04						
SMEC LVDT Primary	2	1	STP	5									0.005	0.0025	0	1	0	0					50%	33%	17%	2.50E-04	1.03E-05						
SMEC LVDT Secondary	4	2	STP	5									0.00005	0.00005	0	1	0	0					50%	33%	17%	5.00E-06	8.25E-09						
SMEC Launch Latch1	4	2	STP	5									0.4	0	0	0	0	0					0%	0%	0%	3.20E+00	0.00E+00						
SMEC Launch Latch1 Confirm	2	1	STP	5									0.001	0	0	0	0	0					0%	0%	0%	1.00E-05	0.00E+00						
SMEC Launch Latch2	4	2	STP	5									0.4	0	0	0	0	0					0%	0%	0%	3.20E+00	0.00E+00						
SMEC Launch Latch2 Confirm	2	1	STP	5									0.001	0	0	0	0	0					0%	0%	0%	1.00E-05	0.00E+00						
SMEC Drive Coil	2	1	STP	5									0.1	0.04	0	1	0	0					50%	33%	17%	1.00E-01	2.64E-03						
SMEC Drive Coil (Rob.)	2	1	STP	5									0.1	0	0	1	0	0					50%	33%	17%	1.00E-01	0.00E+00						
SMEC Drive coil voltage sensor	2	1	STP	500									0.00001	0	0	1	0	0					0%	33%	0%	1.00E-07	0.00E+00						
SMEC Position sensor supplies	4	2	STP	100									0.001	0	0	1	0	0					50%	33%	17%	4.00E-04	0.00E+00						
SMEC Position sensor photodiodes	6	3	STP	1000									0.00002	0	0	1	0	0					50%	33%	17%	2.40E-06	0.00E+00						
SMEC Position sensor photodiodes FB	6	3	STP	1000									0.00001	0	0	1	0	0					50%	33%	17%	6.00E-07	0.00E+00						
Mechanisms Launch Lock Confirm	6	3	STP	1000									0	0	0	0	0	0					0%	0%	0%								
P-Cal Heater	4	1	STQ	10									0.007	0.00175	1	0	0	0					5%	33%	2%	1.96E-03	2.00E-06						
RF Overshield													>80%																0.00E+00				
H2/S12 Aux-R	CVV 12	FCU J12	DBMA 25 S	FCU P12	DBMA 25 P							Sorption Pump Heater	4	0	TQ	10			2.50E-02	0.00E+00	0	0	0		2%	1/3	1%	2.50E-02	0.00E+00				
						Heat switch heaters	8	0	TQ	50			1.50E-03	0.00E+00	0	0	0					2%	1/3	1%	9.00E-04	0.00E+00							
						300mK Thermal Control Heater	4	1	STQ	100			2.00E-03	0.00E+00	0	0	0					50%	1/3	17%	1.60E-03	0.00E+00							
						Spectrometer Stimulus Heater 4%	4	0	TQ	30			9.00E-03	0.00E+00	0	0	0					50%	33.30%	17%	9.72E-03	0.00E+00							
						Spectrometer Stimulus Heater 2%	4	0	TQ	30			7.00E-03	0.00E+00	0	0	0					50%	33.30%	17%	5.88E-03	0.00E+00							
						FPU Thermometry A	44	11	STQ	1000			1.00E-06	0.00E+00	0	0	0					100%	33.00%	33%	4.40E-06	0.00E+00							
						FPU Thermometry B	12	3	STQ	1000			1.00E-06	0.00E+00	0	0	0					100%	33%	33%	1.20E-06	0.00E+00							
						RF Overshield							>80%																0.00E+00				
						H3/S13 Drive-R	CVV 13	FCU J22	DAMA 15 S	FCU P22	DAMA 15 P	FPU Thermometry C	12	3	STQ	1000			1.00E-06	0	0	0	0		100%	33%	33%	1.20E-08	0.00E+00				
												BSM Chop/Juggle Sensors	4	2	STP	1000			1.00E-06	0.00E+00	0	0	0	0.4				100%	33%	33%	4.00E-09	0.00E+00	
												BSM Chop/Juggle Sensors	6	2	STT	1000			1.00E-06	0.00E+00	0	0	0					100%	33%	33%	6.00E-09	0.00E+00	
												BSM Launch latch sense	2	1	STP	1000			0.001	0	0	0	0					0%	0%	0%	2.00E-03	0.00E+00	
												BSM Launch latch solenoid	2	1	STP	10			0.035	0	0	0	0					0%	0%	0%	2.45E-02	0.00E+00	
												BSM Chop motor drive	4	1	STQ	10			0.04	0	0	0	0					50%	33%	17%	6.40E-02	0.00E+00	
												BSM Juggle motor drive	4	1	STQ	10			0.04	0	0	0	0					50%	33%	17%	6.40E-02	0.00E+00	
												SMEC LVDT Primary	2	1	STP	5			0.005	0	0	0	0	0					50%	33%	17%	2.50E-04	0.00E+00
												SMEC LVDT Secondary	4	2	STP	5			0.00005	0	0	0	0	0					50%	33%	17%	5.00E-06	0.00E+00
												SMEC Launch Latch1	4	2	STP	5			0.4	0	0	0	0	0					0%	0%	0%	3.20E+00	0.00E+00
												SMEC Launch Latch1 Confirm	2	1	STP	5			0.001	0	0	0	0	0					0%	0%	0%	1.00E-05	0.00E+00
												SMEC Launch Latch2	4	2	STP	5			0.4	0	0	0	0	0					0%	0%	0%	3.20E+00	0.00E+00
												SMEC Launch Latch2 Confirm	2	1	STP	5			0.001	0	0	0	0	0					0%	0%	0%	1.00E-05	0.00E+00
												SMEC Drive Coil	2	1	STP	5			0.1	0	0	0	0	0					50%	33%	17%	1.00E-01	0.00E+00
												SMEC Drive Coil (Rob.)	2	1	STP	5			0.1	0	0	0	0	0					50%	33%	17%	1.00E-01	0.00E+00
SMEC Drive coil voltage sensor	2	1	STP	500									0.00001	0	0	0	0	0					0%	33%	0%	1.00E-07	0.00E+00						
SMEC Position sensor supplies	4	2	STP	100									0.001	0	0	0	0	0					50%	33%	17%	4.00E-04	0.00E+00						
SMEC Position sensor photodiodes	6	3	STP	1000									0.00002	0	0	0	0	0					50%	33%	17%	2.40E-06	0.00E+00						
SMEC Position sensor photodiodes FB	6	3	STP	1000									0.00001	0	0	0	0	0					50%	33%	17%	6.00E-07	0.00E+00						
Mechanisms Launch Lock Confirm	6	3	STP	1000									0	0	0	0	0	0					0%	0%	0%								
P-Cal Heater	4	2	STP	10									0.007	0	0	0	0	0					5%	33%	2%	1.96E-03	0.00E+00						
RF Overshield													>80%																0.00E+00				



SPIRE HARNESS DEFINITION DOCUMENT

Doc #: SPIRE-RAL-PRJ-000608
Issue: 1.2
Date: 17/02/05
Page 243 of 245

Annex 3. - BDA Channels

This information has been deleted and the Tables have been incorporated into the main part of the document.

Annex 4 - What is 12-ax?

This cable form is maybe not self-explanatory in the same way as the others in this document. A rather specific format of 12-ax is intended.

It is drawn in diagrams as:



This consists of 4 twisted triples, each triple being three insulated multicore wires, inside one braided shield, all inside an outer insulator.

The material, identified by JPL, uses stainless steel for all conductors, nominally 38AWG.

Using the black wires as screens for twisted pairs (red and blue), capacitance and thermal conductivity are low compared to four screened twisted pairs and cross talk is apparently acceptable.

Note that the outer screen is also quite lightweight, and for this reason it is not used as the main RF shield on harnesses in SPIRE.

Annex 5 – CVV Bulkhead EMI Backshells

This section has been removed and the details incorporated within the body of the document



SPIRE HARNESS DEFINITION DOCUMENT

Doc #: SPIRE-RAL-PRJ-000608

Issue: 1.2

Date: 17/02/05

Page 244 of 245

Annex 6 - SPIRE Grounding Diagram

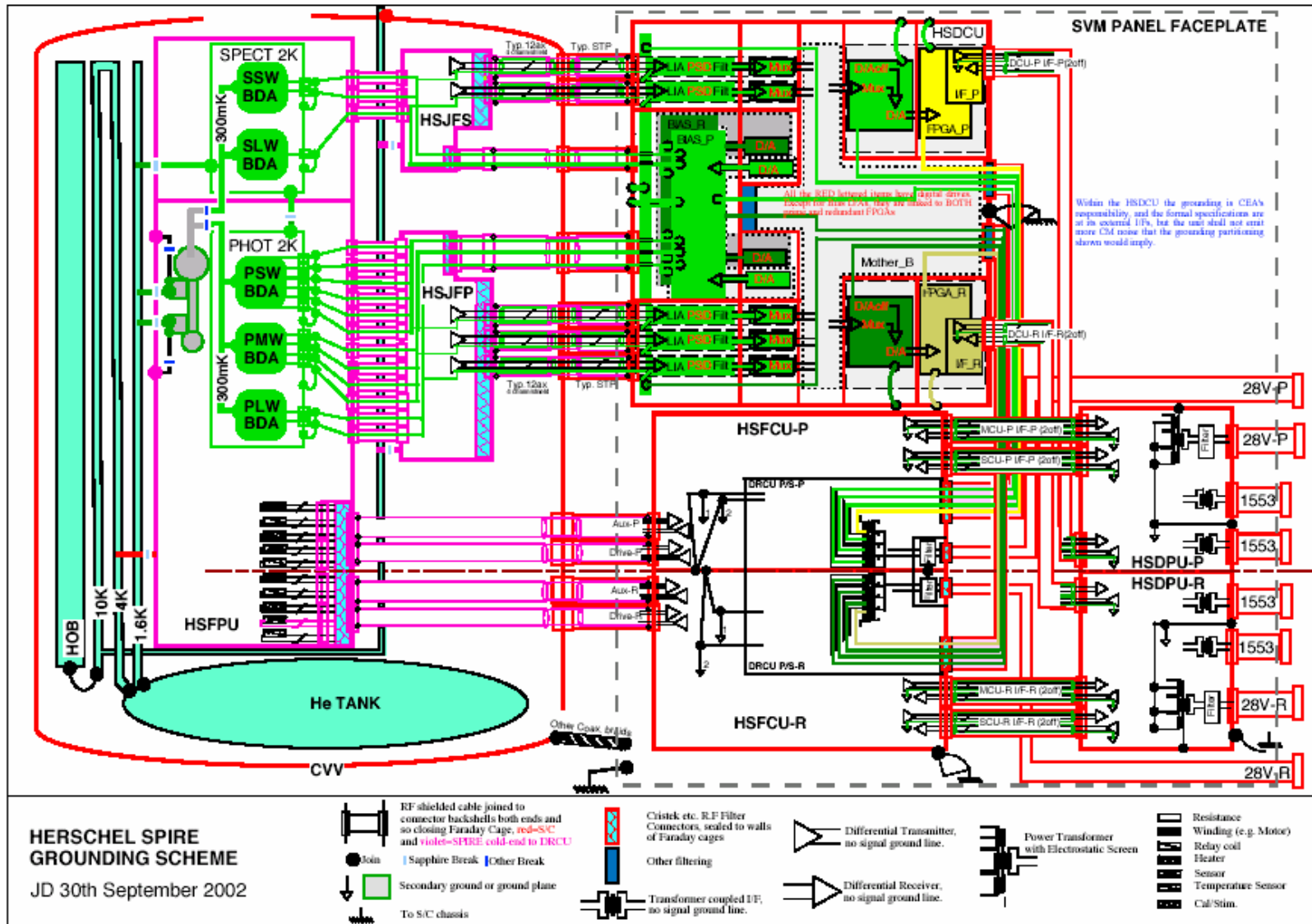

Annex 7 – PTC Cryoharnessing

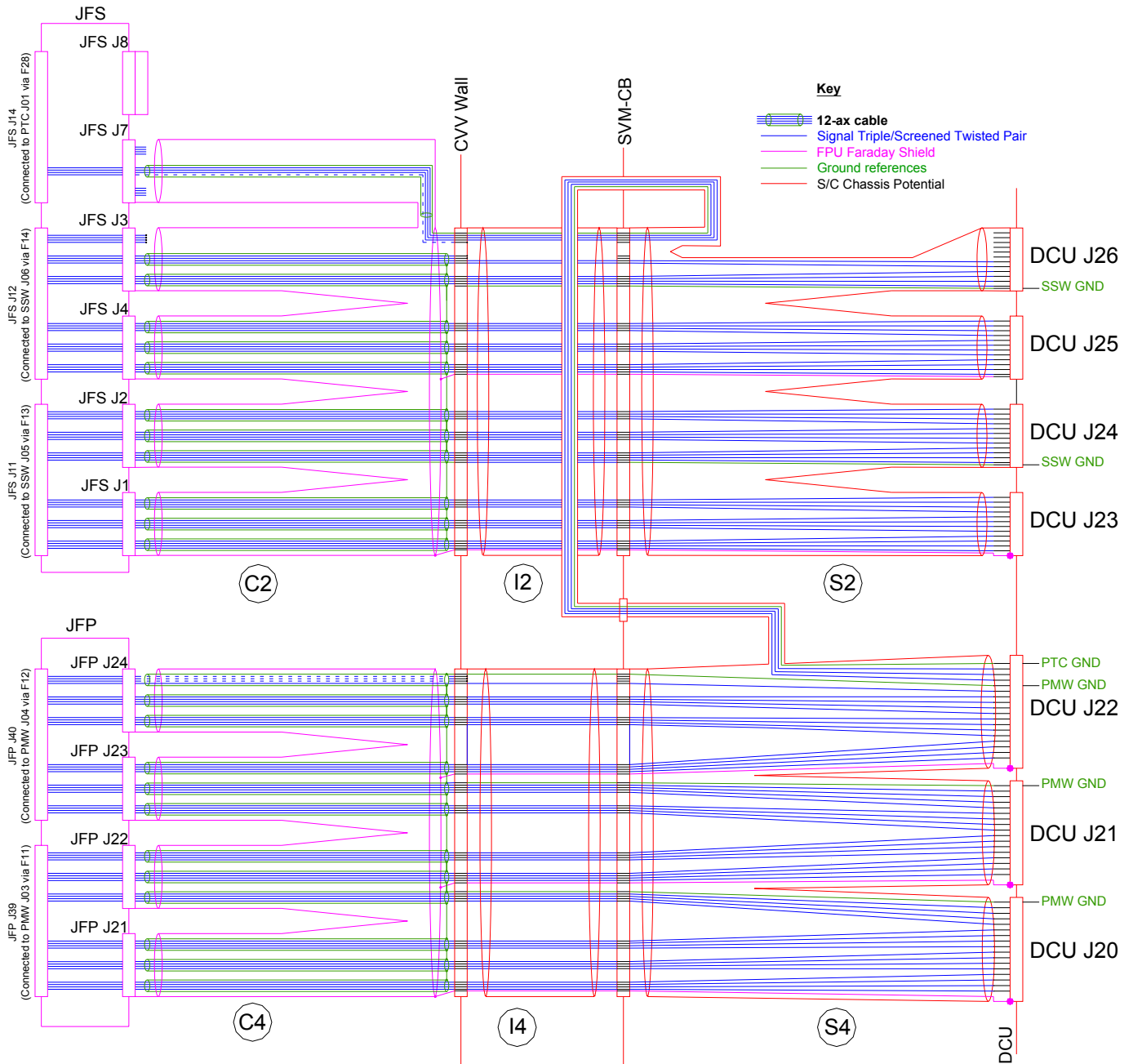

Figure 4-5 - The three channels from the PTC thermistors are conditioned in the Spectrometer JFET module (JFS). The signals are readout by the Photometer LIAs.

End of Doc.